

AD-A068 332

CALIFORNIA INST OF TECH PASADENA GRADUATE AERONAUTIC--ETC F/G 13/9
EXPERIMENTAL STUDY OF THE DYNAMICS OF VARIABLE-LENGTH CABLE SYS--ETC(U)
APR 79 T M WARD N68305-76-C-0033

UNCLASSIFIED

GALCIT-HSWT-1129

CEL-CR-79.006

NL

| OF |
AD
A068332

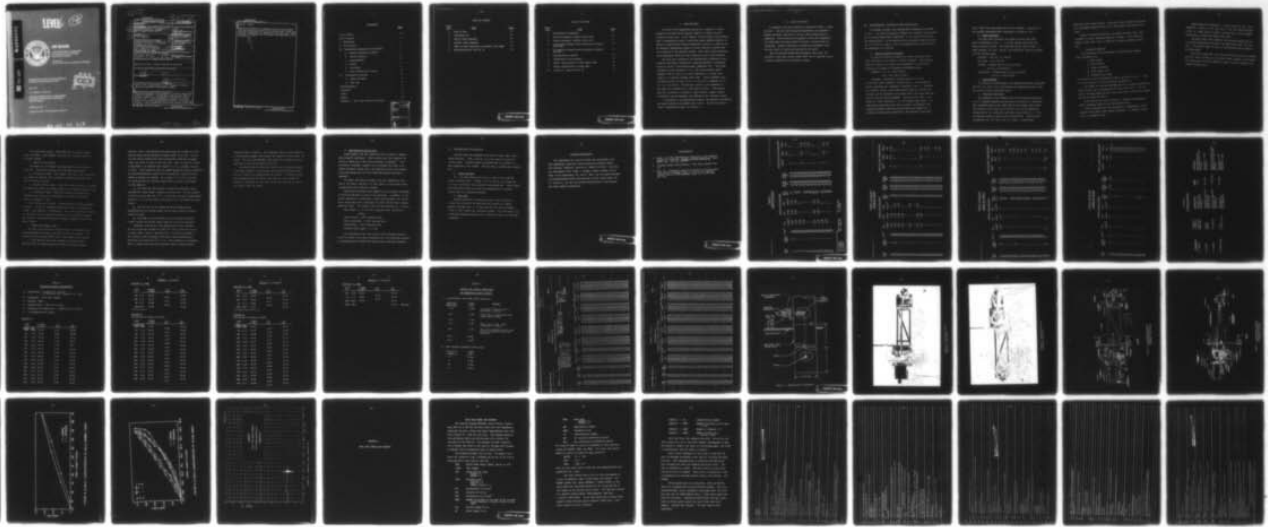

END
DATE
FILMED
6-79
DDC

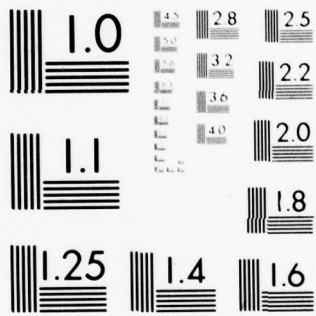

MICROCOPY RESOLUTION TEST CHART
NATIONAL BUREAU OF STANDARDS-1963-A

AD A 068332

DDC FILE COPY

LEVEL *IV*

12
B.S.



CR 79.006

CIVIL ENGINEERING LABORATORY
Naval Construction Battalion Center
Port Hueneme, California

Sponsored by
NAVAL FACILITIES ENGINEERING COMMAND

EXPERIMENTAL STUDY OF THE DYNAMICS OF
VARIABLE-LENGTH CABLE SYSTEMS

April 1979

An Investigation Conducted by

GRADUATE AERONAUTICAL LABORATORIES
CALIFORNIA INSTITUTE OF TECHNOLOGY
Pasadena, California

N68305-76-C-0033

Approved for public release; distribution unlimited.



79 05 07 012

18 CEL

9 Final report

UNCLASSIFIED

SECURITY CLASSIFICATION OF THIS PAGE (When Data Entered)

REPORT DOCUMENTATION PAGE		READ INSTRUCTIONS BEFORE COMPLETING FORM
1. REPORT NUMBER CR-79.006 ✓	2. GOVT ACCESSION NO.	3. RECIPIENT'S CATALOG NUMBER
6 EXPERIMENTAL STUDY OF THE DYNAMICS OF VARIABLE-LENGTH CABLE SYSTEMS	5. TYPE OF REPORT & PERIOD COVERED Final April 1979	
7. AUTHOR(s) Thomas M. Ward	6. PERFORMING ORG. REPORT NUMBER HSWT-1129 ✓	
10	8. CONTRACT OR GRANT NUMBER(s) N68305-76-C-0033 NW	15
9. PERFORMING ORGANIZATION NAME AND ADDRESS Graduate Aeronautical Laboratories California Institute of Technology Pasadena, CA 91125	10. PROGRAM ELEMENT, PROJECT, TASK AREA & WORK UNIT NUMBERS YF52 556 999/01.202A	
11. CONTROLLING OFFICE NAME AND ADDRESS Civil Engineering Laboratory Naval Construction Battalion Center Port Hueneme, CA 93043	11. REPORT DATE April 1979	
14. MONITORING AGENCY NAME & ADDRESS (if different from Controlling Office) Naval Facilities Engineering Command 200 Stovall Street Alexandria, VA 22334	12. NUMBER OF PAGES 57	
12 58 p.	13. SECURITY CLASS. (of this report) Unclassified	
16. DISTRIBUTION STATEMENT (of this Report) Approved for public release; distribution unlimited.	14. DECLASSIFICATION/DOWNGRADING SCHEDULE	
17. DISTRIBUTION STATEMENT (of the abstract entered in Block 20, if different from Report) 62754N		
14 GALCIT-HSWT-1129		
18. SUPPLEMENTARY NOTES		
16 F52556		
19. KEY WORDS (Continue on reverse side if necessary and identify by block number) Anchor; cable; hydrodynamics; variable length; oscillations; laboratory experiments; measurements; dynamics		
20. ABSTRACT (Continue on reverse side if necessary and identify by block number) Laboratory experiments on the dynamics of variable length cable systems are described. The prototype situation that these experiments simulate is the deployment of retrieval of a heavy object at sea. A winching mechanism attached to an electro-mechanical oscillator was mounted over a 65 ft. (20 m) deep tank of water. A mass suspended by elastic and inelastic cables was		

DD FORM 1 JAN 73 1473 EDITION OF 1 NOV 65 IS OBSOLETE

UNCLASSIFIED

SECURITY CLASSIFICATION OF THIS PAGE (When Data Entered)

157 700

See

UNCLASSIFIED

SECURITY CLASSIFICATION OF THIS PAGE (When Data Entered)

Block 20. Cont'd

payed-out and reeled-in at specified velocities and accelerations while being oscillated in the vertical plane. Cable tension data are provided as a function of cable direction, length, velocity, acceleration, and the frequency and amplitude of the oscillator.

UNCLASSIFIED

SECURITY CLASSIFICATION OF THIS PAGE (When Data Entered)

CONTENTS

	<u>Page</u>
List of Tables	iii
List of Figures	v
I. Introduction	1
II. Data Features	2
III. Experimental Apparatus and Procedures	3
A. Electro-mechanical oscillator	3
B. Winch mechanism	4
C. Instrumentation	4
D. Models	7
E. Procedures	8
F. Data reduction and accuracy	12
IV. Presentation of Results	13
A. Tables and plots	13
B. Data tape	13
Acknowledgement	15
References	17
Tables	19
Figures	33
Appendix I. Data Tape Format and Program	43

ACCESSION for	
NTIS	White Section <input checked="" type="checkbox"/>
DDC	Buff Section <input type="checkbox"/>
UNANNOUNCED	<input type="checkbox"/>
JUSTIFICATION	
BY	
DISTRIBUTION/AVAILABILITY CODES	
Dist:	SPECIAL
A	

LIST OF TABLES

<u>Table No.</u>	<u>Title</u>	<u>Page</u>
1	Index of tests	19
2	Transducer list	23
3	Elastic cable properties	24
4	Inelastic cable properties	25
5	Effect of water immersion on inelastic cable length	29
6	Experimental data; Test No. 52	30

PRECEDING PAGE BLANK

LIST OF FIGURES

<u>Figure No.</u>	<u>Title</u>	<u>Page</u>
1	Experimental arrangement	35
2	Electro-mechanical oscillator; winch side	34
3	Electro-mechanical oscillator; drive side	35
4	Arrangement drawing; electro-mechanical oscillator, winch side	36
5	Arrangement drawing; electro-mechanical oscillator, top view	37
6	Instrumentation schematic	38
7	Differentiator circuit diagram	39
8	Elastic characteristics of solid rubber cable	40
9	Elastic characteristics of nylon cable	41
10	Tension vs. time; Test No. 52	42

I. INTRODUCTION

The Navy's Civil Engineering Laboratory is engaged in a major program of research into the dynamic behavior of cables and cable structures in the ocean. A key objective of this program is the development of mathematical models to predict the large amplitude dynamic response of cable structures during implantment, recovery, or while in-situ. An extensive experimental program is being conducted to provide data for verification of the predictive models. This report covers laboratory-scale experiments which have been conducted as part of this program.

The tests were conducted in the Hydrodynamics Laboratory of the Graduate Aeronautical Laboratories, California Institute of Technology, during the period 17 November through 5 December 1977. The model assemblies tested consisted of a 2 in. (50.8 mm) diameter sphere weighing 1.003 lb. (455.4 g) in water supported by an elastic (soft rubber) or an inelastic (braided nylon) cable. These assemblies were oscillated in water at rates of 0.0 to 3.0 Hz and at amplitudes of 0.0 to 1.0 in. (25.4 mm). The direction, velocity, and acceleration of the cable was controlled over a wide range of values. Cable tension data were recorded as a function of cable direction, length, velocity, acceleration, and the frequency and amplitude of the oscillatory motion.

A description of the experimental program, the apparatus, procedures, and typical results are provided in this report. Complete data are provided in supplemental volumes, see Reference 3.

II. DATA FEATURES

A summary of the tests conducted is provided in Table 1, "Index of Tests". The data taken during the experiments are presented in English and Metric (cgs) units in tabular and in plotted form in a supplement. The increment and magnitude of the scales displayed in this report have been held constant to provide a common basis for comparison. Analysts interested in varying the presentation of the data may resort to a data tape described in the report.

Data are provided demonstrating damping, phase shift, and resonance of the cable systems tested; these are of sufficient accuracy to permit verification of the predictive models.

III. EXPERIMENTAL APPARATUS AND PROCEDURES

A schematic drawing of the experimental arrangement is provided as Fig. 1. An electro-mechanical oscillator was attached to the upstream leg of the High Speed Water Tunnel (Ref. 1) at a large port located on the operating level. As the tunnel was not in operation, this leg served as a 65 ft (19.8 m) deep, 5 ft (1.52 m) diameter tank of water in which the experiment was conducted.

A. Electro-mechanical Oscillator

An electro-mechanical oscillator was used to excite the model cable assemblies in the vertical, or heave, direction. The oscillator, which was designed, fabricated, and instrumented as a part of the experiment, is capable of providing the following motions;

Amplitude: 0.0, 0.1, and 1.0 inch

(0.0, 2.54, and 25.4 mm.)

Frequency: Continuously variable from 0.0 to 3.0 Hz.

A side view of the oscillator is shown in Fig. 2. An arrangement drawing identifying the components is provided as Fig. 4. Basically, the oscillator consists of two slider plates driven by eccentric pins. The pins may be positioned on the output shaft of two right angle gear boxes to give the desired amplitude. The gear boxes, Fig. 3, are driven by a shaft connected to a 1/3 HP variable speed motor. Two slider plate mechanisms were used to provide accessibility to the winching mechanism, which was located outside the tunnel riser, to position the cable tension transducer on the centerline of the riser,

and to reduce the reciprocating mass of the assembly. A top view of the assembly indentifying these components is provided as Fig. 5.

B. Winch Mechanism

The cable winch mechanism was fixed to the left hand slider plate as illustrated in Fig. 2. A 1/8 HP variable speed motor was used to drive the capstan. The cable path may be traced in Fig. 4. Cable direction, run time, velocity, and acceleration could be controlled over the following range:

Direction: "Pay-out" or "reel-in"

Run Time: 0.0 to 300 sec

Velocity: Variable from 0.0 to ± 2.0 ft/sec,

(0.0 to ± 0.610 m/sec)

Acceleration: Variable from 0.0 to ± 4.0 ft/sec²

(0.0 to ± 0.914 m/sec².)

C. Instrumentation

Two classes of instrumentation were employed during the experiment. The first was used to set up and monitor the experiment and the second was used to create a permanent record.

1. Monitoring Instruments

The frequency of the oscillator was set and monitored through the use of a magnetic proximity pick-up which was excited by a sixty-tooth gear attached directly to the output shaft of the oscillator drive motor. The amount of cable payed out at the start of a run was determined through the use of a mechanical revolution counter driven by a 1.00 ft. circumference wheel in direct contact with the cable. Cable velocity, acceleration and run time were set using a commercially

fabricated motor control system. Feed-back for this system was provided by a tachometer attached directly to the output shaft of the capstan drive motor.

Signals from these instruments, and others described below, were recorded on a direct writing galvanometer recorder. These temporary analog records were used to verify the successful completion of each test.

2. Recorded Instruments

Five parameters were instrumented and permanently recorded.

These parameters are:

- 1 Cable length,
- 2 Cable velocity,
- 3 Cable acceleration,
- 4 Cable tension, and
- 5 Oscillator phase angle.

A schematic of the instrumentation system is provided as Fig. 6. Table 2 lists the transducers used and provides specifications.

Cable length was measured through the use of a helical potentiometer driven by the 1.00 ft circumference wheel described above. Zero was taken at the point where the end of the cable-anchor assembly just cleared the tension transducer sheave.

Cable velocity data were provided by a separate instrumentation quality tachometer driven by the capstan drive motor.

Cable acceleration data were provided by a differentiator circuit attached to the output of the velocity tachometer. A schematic of this circuit is provided as Fig. 7.

Cable tension was measured by a strain gage load cell which supported a sheave at the right end of the cable path illustrated in Fig. 4. Cable tension is taken as positive when a load is applied which tends to increase the length of the cable.

The phase angle of the oscillator was measured through the use of a rotary potentiometer attached to the slider drive shaft, see Figs. 3 and 5. Zero phase angle was taken as the top-dead-center position of the slider plate.

These data, along with a voice log and switch trace used to identify the tests, were recorded on a seven track analog magnetic tape recorder. The analog tapes were later digitized as part of the data reduction procedure described below.

D. Models

Two model assemblies were tested. The assemblies consisted of an elastic cable supporting a small anchor and a second inelastic cable supporting the same anchor.

1. Anchor

The model anchor was a 2.010 ± 0.010 in (51.05 mm) diameter sphere weighing 455 grams in water. The outside of the sphere was painted with an alternate black and white pattern dividing the surface into eight zones of equal area (see Figs. 2 and 3). The cables were attached to the anchor by means of a fishing tackle snap swivel which hooked into a small stud projecting from the surface of the anchor.

2. Elastic Cable

The dynamic response of an elastic system was simulated through the use of a soft rubber cable attached to the anchor. The mechanical properties of this cable are provided in Table 3. The notation used in the load vs. deflection data found in this table, and also in Table 4, is as follows:

L = the length of the cable as measured immediately following the application of the load

L_1 = the cable length approximately one minute following the application of the load

ΔL = the change in L between loadings including creep.

A plot of the elastic characteristics is provided as Fig. 8. As this material is plastic, any stress-strain curve obtained from these data must be considered an approximation.

3. Inelastic Cable

The response of an inelastic system was simulated through the use of a braided nylon line attached to the anchor. This cable had approximately four times the axial stiffness of the rubber cable. Mechanical properties of this cable are provided in Table 4.

A series of three load-deflection tests were conducted on a six foot specimen of nylon line after being pre-conditioned as follows. First, the line was soaked in water for twenty-four hours. After removal one end was fixed and the other attached to a weight pan. Next, the line was exercised fifteen times by repeatedly loading it with a two pound weight. The results of all three tests are provided in Table 4. Plots of the data are provided as Fig. 9.

Measurements were also made to determine the effect of water immersion on the elongation of the cable under steady load (i. e., "creep"). These data are provided in Table 5.

E. Procedures

Many of the procedures, e. g., setting the oscillator amplitude and frequency, are trivial and are not described. Other less obvious procedures are described below.

1. Pre, and Post-run data

Two time columns appear in the tabulated data of Appendix I. The first, "RCDR TIME SEC" for record time in seconds, is the length of the record. Recordings of the signals from all the instruments were made for approximately 10 sec prior to, and following, the pay-out or reel-in of the cable. These records provide cable tension data which results only from the motion of the oscillator.

The second time column, "RUN TIME SEC" for winch running time in seconds, is the duration of the pay-out or reel-in motion of the winch capstan.

2. Winch velocity profile

The winch was run through a preprogrammed velocity profile for each test. The profile consisted of the following three phases:

a. Acceleration Phase: The capstan, and cable, were accelerated at a fixed rate until the winch tachometer indicated the desired cable velocity had been achieved.

b. Constant Velocity Phase: After the desired velocity was obtained, the capstan was driven at constant velocity for a specified amount of time.

c. Deceleration Phase: When the constant velocity phase was completed, the capstan was decelerated at a constant rate until the cable was brought to a stop.

The accelerations, velocities, and decelerations used are identified in Table I. A zero is sometimes listed in the "Dec" or deceleration column. This indicates a "Crash Stop." The crash stop, which simulates an emergency stop or jamming of the winch, was achieved by bringing the capstan to a halt with the dynamic breaking capability of the winch motor control.

3. Initial cable length setting

The tests were run in pay-out/reel-in pairs for which data were taken during the pay-out phase and again for the reel-in phase. The procedure used to set the initial value of cable length was as follows:

a. The cable was set on the oscillator so that the anchor hung just below the tangent point on the tension transducer sheave.

Next the 1.00 ft. circumference measuring wheel was brought in contact with the cable and the mechanical footage counter set to zero. At this time the helical potentiometer which provided the cable pay-out length signal was moved 1/4 turn off the zero stop. This 1/4 turn bias, which corresponded to an indicated cable length of 2.2 ft., provided a margin of safety. In the event the cable was pulled through the tension transducer, the helical potentiometer would not be run against its stop and the possibility of damage was avoided. As a result, 2.2 ft. (67.1 cm) must be subtracted from the tabulated length values to arrive at the length of cable deployed.

b. The cable was then winched out until the mechanical counter indicated the "initial length" required by the test plan. For the majority of the pay-out runs this was 5.0 ft. At this time the helical potentiometer indicated 7.2 ft. and the bottom of the anchor was 3 feet below the water surface.

c. The test was run by running the winch through the pre-programmed pay-out velocity profile and the anchor would be lowered through the water.

d. The cable was next winched in or out until the mechanical counter indicated the desired initial length for the reel-in test phase.

Elongation of the elastic cable following pay-out was observed. On one occasion the mechanical counter was used to winch out 20 feet of elastic cable. Next, an indicated 20 ft. of cable was winched in. The amount of cable remaining in the water, when measured with a steel tape, was found to be 11 ft. 7 in. This elongation is unavoidable and is a result of the fact that unstretched cable is payed-out while

stretched cable is reeled-in. The stretching, which is time dependent, is caused by the weight of the anchor, the distributed cable weight, and creep. The actual and indicated cable length were brought into agreement prior to the pay-out phase of each run.

Note that on the occasion cited, where large stretching occurred, a 455 gram anchor was used and the time period involved from initial pay-out to reel-in was approximately two minutes. In order to reduce this stretching during the elastic cable tests the anchor weight was limited to a maximum of 150 grams and the time duration of a given test held to order one minute.

F. Data Reduction and Accuracy

Analog signals from the transducers were recorded on magnetic tape during the experiment. These records were later digitized and stored on digital tape in the format described in Appendix I. Tare corrections, including a dynamic tare to eliminate the effect of the tension transducer sprung mass, and calibration factors were applied to the data through the use of the FORTRAN program provided in Appendix I.

The tables and figures provided in the data supplement to this report, and Table 6 and Fig. 10 of this report, are the result of this computer-based data reduction technique.

Steady-state excitations were applied to each transducer separately to verify the specified accuracy of the instrument. In addition, an end-to-end calibration was performed in which each transducer was excited with a known input and a comparison was made with the final computer generated output. The results of the over-all calibration are as follows:

Cable length: 0.1 ft or 0.8% of indicated value, whichever is
greater

Cable velocity: $\pm 2\%$ of indicated value

Cable acceleration: $\pm 5\%$ of indicated value

Cable tension: $\pm 1\%$ of indicated value

Oscillator phase angle: ± 2.5 deg

The assessment of the cable velocity and acceleration precision is not as certain as the other parameters due to the difficulties inherent in establishing known steady-state velocity and acceleration standards.

IV. PRESENTATION OF RESULTS

The data taken are presented in the form of tables, plots, and a digital data tape. Table 6 and Fig. 10 of this report are typical of the data taken. Complete tabular and plotted data are available as a data supplement to this volume. The data tape is available upon request, Ref. 2.

A. Tables and plots

A 0.1 sec time interval was used as a time base in both the tabular and plotted data. Further, a five lb tension scale range and a 120 sec record time were selected for the plotted data. These ranges have been held constant in all the data presented here to provide a common base for comparative purposes.

B. Data Tape

Analysts interested in varying the format of the results (e.g., to reduce the interval of the time base) are referred to a digital magnetic data tape, Ref. 2, on which the data have been recorded at a rate of 1,000 samples per second per channel. The tape format, and a FORTRAN language program used to control the output, are described in Appendix I.

ACKNOWLEDGEMENTS

This experiment was carried out under the sponsorship of the Civil Engineering Laboratory, Naval Construction Battalion Center, Port Hueneme, California, Contract No. N68305-76-C-0033. The Navy was represented by Mr. Dallas J. Meggitt, program manager and initiator of the experiments, Mr. Earl F. Buck, who was present throughout the experimental portion of the program, and Mr. Steve Sergev and Dr. Francis C. Liu who were present during portions of the program and made technical contributions.

PRECEDING PAGE BLANK

REFERENCES

1. Ward, T.M. "The Hydrodynamics Laboratory at the California Institute of Technology", Journal of Fluids Engineering. Trans. ASME, Dec. 1976, pp. 740-748.
2. "Variable Length Cable Dynamics", Data Tape available from CEL.
3. Ward, T.M. "Experimental Study of the Dynamics of Variable-Length Cable Systems," Supplement Volume I, CEL CR 79.007; Supplement Volume II, CEL CR 79.008; Supplement Volume III, CEL CR 79.009, Apr. 1979.

PRECEDING PAGE BLANK

TABLE 1

INDEX OF TESTS

WINCH PARAMETERS

OSCILLATOR PARAMETERS

Test No.	Cable Matl. ¹	Dir. ²	Acc. ft/sec ²	Vel. ft/sec	Dec. ft/sec ²	Run time sec	Initial length ft	Final length ft	Mode ³	Amp. inch	Freq. Hz
1	N	PO	0.25	0.50	0.25	117	5.00	49.70	S	0	0
2	"	RI	"	"	"	"	55.10	11.75	"	"	"
3	"	PO	1.00	2.00	1.00	42	5.00	46.00	"	"	"
4	"	RI	"	"	"	41	55.00	12.10	"	"	"
5	"	PO	3.00	"	0	45	5.00	49.40	"	"	"
6	"	RI	"	"	"	"	55.00	11.20	"	"	"
7	"	PO	1.00	"	"	"	5.00	47.50	D	0.10	0.50
8	"	RI	"	"	"	44	55.00	10.00	"	"	"
9	"	PO	"	"	"	45	5.00	50.90	"	"	1.50
10	"	RI	"	"	"	44	55.00	10.00	"	"	"
11	"	PO	"	"	"	40	5.00	48.00	"	"	2.50
12	"	RI	"	"	"	39	55.00	12.25	"	"	"
13	"	PO	0.25	0.50	0.25	120	5.00	49.40	S	0	0
14	"	RI	"	"	"	116	55.00	12.20	"	"	"
15	"	PO	1.00	2.00	1.00	42	5.00	47.30	"	"	"
16	"	RI	"	"	"	"	55.00	12.45	"	"	"
17	"	PO	3.00	"	0	44	5.00	48.40	"	"	"
18	"	RI	"	"	"	43	55.00	9.90	"	"	"
19	"	PO	1.00	"	"	47	5.00	50.50	D	0.10	0.50
20	"	RI	"	"	"	44	55.00	9.90	"	"	"
21	"	PO	"	"	"	43	5.00	50.80	"	"	1.50
22	"	RI	"	"	"	44	55.00	9.50	"	"	"

¹ N = Nylon
R = Rubber
S = Static

² PO = pay-out
RI = reel-in

³ D = Dynamic
S = Static

TABLE 1 (Continued)
INDEX OF TESTS

WINCH PARAMETERS										OSCILLATOR PARAMETERS			
Test No.	Cable ₁ Matl.	Dir. ²	Acc. ft/sec ²	Vel. ft/sec	Dec. ft/sec ²	Run time sec	Initial length ft	Final length ft	Mode ³	Amp. inch	Freq. Hz		
23	N	PO	1.00	2.00	0	46	5.00	51.30	D	0.10	2.50		
24	"	RI	"	"	"	46	55.00	10.20	"	"	"		
25	R	PO	0.25	0.50	0.25	74	5.00	28.45	S	0	0		
26	"	RI	"	"	"	117	30.00	-10.70	"	"	"		
27	"	PO	1.00	2.00	1.00	32	5.00	28.20	"	"	"		
28	"	RI	"	"	"	46	35.00	-6.00	"	"	"		
29	"	PO	3.00	2.00	0	33	5.00	28.60	"	"	"		
30	"	RI	"	"	"	42	30.00	3.00	"	"	"		
31	"	PO	"	"	"	38	5.00	29.75	"	"	"		
32	"	RI	"	"	"	28	30.00	7.50	"	"	"		
33	"	PO	1.00	"	1.00	36	5.00	26.10	"	"	"		
34	"	RI	"	"	"	32	30.00	9.70	"	"	"		
35	"	PO	"	"	"	44	5.00	29.60	"	"	"		
36	"	RI	"	"	"	43	30.00	9.40	"	"	"		
37	"	PO	0.25	0.50	0.25	69	5.00	29.05	"	"	"		
38	"	RI	"	"	"	87	30.00	2.50	"	"	"		
39	"	PO	1.00	2.00	0	36	5.00	30.80	D	1.00	0.50		
40	"	RI	"	"	"	33	30.00	5.70	"	"	"		
41	"	PO	"	"	"	35	5.00	31.10	"	"	1.50		
42	"	RI	"	"	"	30	30.00	5.80	"	"	"		
43	"	PO	"	"	"	31	5.00	29.55	"	"	2.50		
44	"	RI	"	"	"	35	30.00	6.20	"	"	"		
45	"	PO	"	"	"	29	5.00	30.05	"	"	"		
46	"	RI	"	"	"	31	30.00	7.70	"	"	"		
47	"	PO	"	"	"	33	5.00	29.50	"	"	1.50		
48	"	RI	"	"	"	29	30.00	6.40	"	"	"		
49	"	PO	"	"	"	31	5.00	31.00	"	"	0.50		
50	"	RI	"	"	"	30	30.00	7.60	"	"	"		

TABLE 1 (Continued)

INDEX OF TESTS

WINCH PARAMETERS

OSCILLATOR PARAMETERS

Test No.	Cable ₁ Matl.	Dir. ²	Acc. ft/sec ²	Vel. ft/sec	Dec. ft/sec ²	Run time sec	Initial length ft	Final length ft	Mode ³	Amp. inch	Freq. Hz
51	N	PO	1.00	2.00	0	47	5.00	49.20	D	1.00	0.50
52	"	RI	"	"	"	45	55.00	10.20	"	"	"
53	"	PO	"	"	"	51	5.00	51.30	"	"	1.50
54	"	RI	"	"	"	44	55.00	9.80	"	"	"
55	"	PO	"	"	"	"	5.00	49.60	"	"	"
56	"	RI	"	"	"	"	55.00	10.10	"	"	"
57	"	PO	"	"	"	49	5.00	51.45	"	"	0.50
58	"	RI	"	"	"	46	55.00	9.20	"	"	"
59	R	PO	"	"	"	37	5.00	29.20	"	"	0.25
60	"	RI	"	"	"	30	30.00	8.60	"	"	"
61	"	PO	"	"	"	34	5.00	29.00	"	"	0.10
62	"	RI	"	"	"	29	30.00	8.40	"	"	"
63	"	PO	"	"	"	30	5.00	29.30	"	"	2.67
64	"	RI	"	"	"	31	30.00	7.60	"	"	"
65	"	PO	"	"	"	29	5.00	30.40	"	"	1.00
66	"	RI	"	"	"	30	30.00	5.70	"	"	"
67	"	PO	"	"	"	29	5.00	29.75	"	"	"
68	"	RI	"	"	"	"	30.00	8.50	"	"	"
69	"	PO	"	"	"	32	5.00	30.60	"	"	2.67
70	"	RI	"	"	"	30	30.00	7.40	"	"	"
71	"	PO	"	"	"	34	5.00	32.10	"	"	0.10
72	"	RI	"	"	"	37	30.00	5.20	"	"	"
73	"	PO	"	"	"	38	5.00	26.25	"	"	0.25
74	"	RI	"	"	"	32	30.00	8.40	"	"	"
75	N	S	0	0	"	15	6.45	6.45	S	0	0
76	"	"	"	"	"	"	"	"	D	1.00	1.00
77	"	"	"	"	"	6	"	"	"	"	"

TABLE 2

TRANSDUCER LIST

<u>Parameter</u>	<u>Transducer Type</u>	<u>Manufacturer</u>	<u>Range</u>	<u>Precision</u>
1) Tension	Strain gage load cell	Tensitron, Inc. Harvard, Mass. S/N 27077	± 5 lb.	Combined linearity and hysteresis: ± 0.5% full scale
2) Length	10 turn Helipot	Beckman Instruments Fullerton, Ca. Model A-R50k	50k ohm	Linearity: ± 0.25% full scale
3) Velocity	Tachometer	Sierracin-Magneddyne Carlsbad, Ca. P/N 435-05	± 3800 rpm	Sensitivity: 9.97V/K rpm Ripple: 0.12% full scale, pk to pk.
4) Phase Angle	Rotary Potentiometer	Bourns, Inc. Riverside, Ca. P/N 3445S-503	50 k ohm	Linearity: ± 0.2% full scale Dead band: 2 deg.

TABLE 3
ELASTIC CABLE PROPERTIES⁽¹⁾

- A. Manufacturer: Marsh Industries, Inc.
49680 Leona Dr., Mt. Clemens, MI 48043
- B. Designation: Rubber Shock Mitigation Cord
- C. Material: Solid rubber
- D. Diameter: 0.159 inch (4.04 mm)
- E. Weight per unit length: 0.0092 lb/ft (13.7 g/m)
- F. Load deflection test results:

<u>Load</u>		Length L, inch	ΔL inch	L ₁ inch
gram	lbs			
Pan	Pan	76.187		76.312
50	0.11	79.156	+2.969	79.281
100	0.22	82.562	+3.406	83.000
150	0.33	86.750	+4.188	87.060
100	0.22	83.812	-2.938	83.750
50	0.11	80.125	-3.687	80.000
Pan	Pan	76.812	-3.313	76.620 ⁽²⁾

Notes:

- 1) Dry cable in air
- 2) After two minutes, the length was 76.593 inch.

TABLE 2
TRANSDUCER LIST

<u>Parameter</u>	<u>Transducer Type</u>	<u>Manufacturer</u>	<u>Range</u>	<u>Precision</u>
1) Tension	Strain gage load cell	Tensitron, Inc. Harvard, Mass. S/N 27077	± 5 lb.	Combined linearity and hysteresis: ± 0.5% full scale
2) Length	10 turn Helipot	Beckman Instruments Fullerton, Ca. Model A-R50k	50k ohm	Linearity: ± 0.25% full scale
3) Velocity	Tachometer	Sierracin-Magnedyne Carlsbad, Ca. P/N 435-05	± 3800 rpm	Sensitivity: 9.97V/K rpm Ripple: 0.12% full scale, pk to pk.
4) Phase Angle	Rotary Potentiometer	Bourns, Inc. Riverside, Ca. P/N 3445S-503	50 k ohm	Linearity: ± 0.2% full scale Dead band: 2 deg.

TABLE 4
INELASTIC CABLE PROPERTIES

- A. Manufacturer: Cortland Line Company
 67 East Court St., Cortland, NY 13045
- B. Designation: 100 lb test, braided
- C. Material: Nylon
- D. Diameter (dry): 0.059 in (1.50 mm)
- E. Weight per unit length (dry): 0.000792 lb/ft (1.18 g/m)
- F. Load-deflection test results:

Test No. 1

Load w,		Length L, inch	ΔL inch	L_1 inch
grams	lbs			
PAN	PAN	75.80	0.16	75.81
50	0.11	75.96	0.14	76.08
100	0.22	76.10	0.10	76.13
150	0.33	76.20	0.09	76.21
200	0.44	76.29	0.05	76.3
250	0.55	76.34	0.06	76.34
300	0.66	76.40	0.05	76.40
350	0.77	76.45	0.03	76.45
400	0.88	76.48	0.02	76.48
450	0.99	76.50	-0.06	76.50
400	0.88	76.44	-0.07	76.43
350	0.77	76.37	-0.08	76.35
300	0.66	76.29	-0.09	76.28
250	0.55	76.20	-0.07	76.19
200	0.44	76.13	-0.09	76.12

TABLE 4 (Continued)

Test No. 1 - cont.

Load w,	Length L, inch	Δ L inch	L ₁ inch
150 0.33	76.04		76.02
100 0.22	75.99	-0.05	75.94
50 0.11	75.88	-0.11	75.87
PAN PAN	75.80	-0.08	75.78

Test No. 2

(re-wet line 30 minutes in water)

Load w,	Length L, inch	Δ L inch	L ₁ inch
grams lbs. PAN PAN	75.78		75.79
50 0.11	76.02	0.24	76.04
100 0.22	76.14	0.12	76.06
150 0.33	76.23	0.09	76.25
200 0.44	76.30	0.07	76.33
250 0.55	76.38	0.08	76.40
300 0.66	76.48	0.10	76.49
350 0.77	76.52	0.04	76.50
400 0.88	76.53	0.01	76.50
450 0.99	76.54	0.01	76.51
400 0.88	76.47	-0.07	76.38
350 0.77	76.39	-0.08	76.35
300 0.66	76.33	-0.06	76.30
250 0.55	76.23	-0.10	76.20
200 0.44	76.17	-0.06	76.14
		-0.13	

TABLE 4 (Continued)

Test No. 2 - cont.

Load w,		Length L, inch	ΔL inch	L_1 inch
150	0.33	76.04		76.03
100	0.22	75.98	-0.06	75.96
50	0.11	75.85	-0.13	75.83
PAN	PAN	75.76	-0.09	75.73

Test No. 3

(re-wet line 30 minutes in water)

Load w,		Length L, inch	ΔL inch	L_1 inch
grams	lbs.			
PAN	PAN	75.70		75.71
50	0.11	75.94	0.24	75.98
100	0.22	76.08	0.14	76.01
150	0.33	76.18	0.10	76.11
200	0.44	76.29	0.11	76.30
250	0.55	76.34	0.05	76.36
300	0.66	76.41	0.07	76.42
350	0.77	76.47	0.06	76.45
400	0.88	76.50	0.03	76.47
450	0.99	76.50	0.0	76.47
400	0.88	76.42	-0.08	76.40
350	0.77	76.34	-0.08	76.32
300	0.66	76.27	-0.07	76.25
250	0.55	76.18	-0.09	76.15
200	0.44	76.09	-0.09	76.08
150	0.33	76.00	-0.09	75.90
			-0.07	

TABLE 4 (Concluded)

Test No. 3 - cont.

Load w,		Length L, inch	ΔL inch	L_1 inch	
100	0.22	75.93		75.90	
50	0.11	75.81	-0.12	75.79	
PAN	PAN	75.74	-0.07	75.72	
PAN	PAN			75.13	(30 min.)

TABLE 5

EFFECT OF WATER IMMERSION
ON INELASTIC CABLE LENGTH

I. Long duration creep under tension when wet:

<u>Immersion time, hrs.</u>	<u>Length m</u>	<u>Remarks</u>
0.0	9.000	Dry length measured prior to immersion \pm 0.001 m.
23.5	9.100	Cable held in tension with model anchor when in water
47.5	9.100	
71.5	9.100	After 5 min. in air, chord contracted to 9.095 m.
95.5	9.100	The chord exhibited the short time drying contractions listed in the task below
167.0	10.080	
213.0	9.080	

II. Short duration contraction when drying:

<u>Time in air min.</u>	<u>Length m</u>
0	9.100
5	9.095
10	9.088
15	9.075

EXPERIMENTAL DATA

VARIABLE LENGTH CABLE SYSTEMS DYNAMICS

TEST NO. 52 WINC# PARAMETERS NYLON OSCILLATOR PARAMETERS DATA PARAMETERS

CABLE MATERIAL NYLON MODE STATIC ID = 60

DIJECTION PAY-OUT APPLITUDE, INCH. 0.0 NREC = 117

ACCELERATION, FPS2 0.25 FREQUENCY, HZ 0.0 NCHN = 6

VELOCITY, FPS 0.50 MNRD = 6000

ACCELERATION, FPS2 0.25 RUN TIME, SEC 117.00 KV = 1.170E-01

INITIAL LENGTH, FT 5.00 FINAL LENGTH, FT 49.70 KA = 1.120E-01

RCOR TIME SEC	RUN TIME SEC	OSCL. ANGLE DEG	TENSION			ENGLISH UNITS			METRIC UNITS			ACCEL. CM/SEC/SEC
			LBS	FT/SEC	ACCEL. FT/SEC/SEC	GRAM	CM	CM/SEC	CM/SEC/SEC			
0.0	0.0	1.6	1.002E 00	3.737E-03	-1.449E-03	4.545E 02	2.191E 02	-1.139E-01	-4.415E-02			
0.100	0.0	1.6	1.001E 00	-3.915E-03	-1.455E-03	4.541E 02	2.151E 02	-1.153E-01	-4.448E-02			
0.200	0.0	1.5	1.002E 00	-3.817E-03	-1.611E-03	4.547E 02	2.150E 02	-1.163E-01	-4.911E-02			
0.300	0.0	1.5	1.003E 00	-4.042E-03	-1.524E-03	4.550E 02	2.187E 02	-1.232E-01	-4.657E-02			
0.400	0.0	1.5	1.002E 00	-3.830E-03	-1.624E-03	4.547E 02	2.185E 02	-1.167E-01	-4.951E-02			
0.500	0.0	1.7	9.985E-01	-4.119E-03	-1.454E-03	4.529E 02	2.187E 02	-1.255E-01	-4.632E-02			
0.600	0.0	1.7	9.989E-01	-3.735E-03	-1.354E-03	4.530E 02	2.187E 02	-1.138E-01	-4.132E-02			
0.700	0.0	1.6	9.951E-01	-3.860E-03	-1.554E-03	4.532E 02	2.184E 02	-1.176E-01	-4.738E-02			
0.800	0.0	1.7	9.954E-01	-4.061E-03	-1.304E-03	4.532E 02	2.184E 02	-1.238E-01	-3.973E-02			
0.900	0.0	1.7	9.931E-01	-3.563E-03	-1.580E-03	4.532E 02	2.185E 02	-1.108E-01	-4.815E-02			
1.000	0.0	1.7	9.931E-01	-3.582E-03	-1.487E-03	4.532E 02	2.186E 02	-1.092E-01	-4.534E-02			
1.100	0.0	1.7	9.952E-01	-3.712E-03	-1.584E-03	4.532E 02	2.184E 02	-1.131E-01	-4.628E-02			
1.200	0.0	1.7	9.951E-01	-3.659E-03	-1.442E-03	4.532E 02	2.187E 02	-1.115E-01	-4.398E-02			
1.300	0.0	1.6	9.967E-01	-3.571E-03	-1.537E-03	4.530E 02	2.185E 02	-1.085E-01	-4.654E-02			
1.400	0.0	1.7	9.953E-01	-3.579E-03	-1.325E-03	4.532E 02	2.185E 02	-1.091E-01	-4.171E-02			
1.500	0.0	1.7	9.980E-01	-3.658E-03	-1.351E-03	4.527E 02	2.152E 02	-1.115E-01	-4.117E-02			
1.600	0.0	1.7	9.987E-01	-3.577E-03	-1.381E-03	4.530E 02	2.152E 02	-1.050E-01	-4.209E-02			
1.700	0.0	1.7	9.983E-01	-3.567E-03	-1.289E-03	4.528E 02	2.153E 02	-1.087E-01	-3.925E-02			
1.800	0.0	1.6	9.955E-01	-3.612E-03	-1.463E-03	4.534E 02	2.185E 02	-1.101E-01	-4.459E-02			
1.900	0.0	1.6	9.994E-01	-3.628E-03	-1.486E-03	4.533E 02	2.187E 02	-1.106E-01	-4.530E-02			
2.000	0.0	1.7	9.954E-01	-3.523E-03	-1.502E-03	4.533E 02	2.187E 02	-1.156E-01	-4.582E-02			
2.100	0.0	1.6	9.956E-01	-3.620E-03	-1.420E-03	4.534E 02	2.191E 02	-1.103E-01	-4.328E-02			
2.200	0.0	1.7	9.950E-01	-3.754E-03	-1.415E-03	4.532E 02	2.150E 02	-1.144E-01	-4.313E-02			
2.300	0.0	1.7	9.987E-01	-3.709E-03	-1.425E-03	4.530E 02	2.185E 02	-1.131E-01	-4.344E-02			
2.400	0.0	1.7	9.985E-01	-3.542E-03	-1.405E-03	4.525E 02	2.187E 02	-1.201E-01	-4.282E-02			
2.500	0.0	1.7	9.990E-01	-3.615E-03	-1.515E-03	4.532E 02	2.185E 02	-1.102E-01	-4.617E-02			
2.600	0.0	1.7	9.992E-01	-3.406E-03	-1.611E-03	4.534E 02	2.185E 02	-1.038E-01	-4.605E-02			
2.700	0.0	1.6	9.992E-01	-3.626E-03	-1.511E-03	4.532E 02	2.185E 02	-1.105E-01	-4.511E-02			
2.800	0.0	1.6	9.986E-01	-3.587E-03	-1.550E-03	4.525E 02	2.151E 02	-1.093E-01	-4.726E-02			
2.900	0.0	1.7	9.981E-01	-3.498E-03	-1.345E-03	4.527E 02	2.152E 02	-1.066E-01	-4.101E-02			
3.000	0.0	1.6	9.975E-01	-3.343E-03	-1.440E-03	4.525E 02	2.150E 02	-1.019E-01	-4.390E-02			
3.100	0.0	1.7	9.983E-01	-3.276E-03	-1.292E-03	4.528E 02	2.155E 02	-9.986E-02	-3.936E-02			
3.200	0.0	1.8	9.985E-01	-3.608E-03	-1.409E-03	4.525E 02	2.155E 02	-1.095E-01	-4.294E-02			

EXPERIMENTAL DATA

VARIABLE LENGTH CABLE SYSTEMS DYNAMICS

RCDR TIME SEC	RUN TIME SEC	OSCL. ANGLE DEG	ENGLISH UNITS			METRIC UNITS			
			TENSION LBS	LENGTH FT	VELOCITY FT/SEC	TENSION GRAM	LENGTH CM	VELOCITY CM/SEC	
3.400	0.0	1.7	9.983E-01	7.21	-3.655E-03	4.528E 02	2.157E 02	-1.114E-01	-3.675E-02
3.500	0.0	1.8	9.982E-01	7.20	-3.676E-03	4.528E 02	2.154E 02	-1.120E-01	-3.982E-02
3.600	0.0	1.8	9.985E-01	7.18	-3.434E-03	4.528E 02	2.188E 02	-1.047E-01	-4.665E-02
3.700	0.0	1.7	1.000E 00	7.19	-3.427E-03	4.528E 02	2.150E 02	-1.045E-01	-4.467E-02
3.800	0.0	1.7	9.991E-01	7.20	-3.546E-03	4.528E 02	2.154E 02	-1.081E-01	-4.480E-02
3.900	0.0	1.7	9.980E-01	7.19	-3.326E-03	4.527E 02	2.150E 02	-1.014E-01	-4.355E-02
4.000	0.0	1.7	1.000E 00	7.18	-3.174E-03	4.538E 02	2.150E 02	-9.673E-02	-4.586E-02
4.100	0.0	1.7	1.000E 00	7.17	-1.550E-03	4.536E 02	2.185E 02	-9.647E-02	-4.724E-02
4.200	0.0	1.8	9.999E-01	7.18	-1.460E-03	4.535E 02	2.187E 02	-9.571E-02	-4.451E-02
4.300	0.0	1.7	9.957E-01	7.18	-3.460E-03	4.535E 02	2.187E 02	-1.055E-01	-4.505E-02
4.400	0.0	1.7	9.988E-01	7.18	-1.421E-03	4.530E 02	2.187E 02	-9.355E-02	-4.330E-02
4.500	0.0	1.8	9.981E-01	7.19	-1.390E-03	4.528E 02	2.152E 02	-9.851E-02	-4.238E-02
4.600	0.0	1.8	9.980E-01	7.20	-1.314E-03	4.527E 02	2.154E 02	-9.464E-02	-4.005E-02
4.700	0.0	1.5	9.981E-01	7.19	-1.317E-03	4.527E 02	2.152E 02	-9.229E-02	-4.013E-02
4.800	0.0	1.8	9.951E-01	7.20	-2.559E-03	4.524E 02	2.155E 02	-9.018E-02	-3.955E-02
4.900	0.0	1.8	9.983E-01	7.21	-2.917E-03	4.528E 02	2.154E 02	-8.851E-02	-4.165E-02
5.000	0.0	1.7	9.981E-01	7.21	-3.456E-03	4.527E 02	2.157E 02	-1.053E-01	-3.556E-02
5.100	0.0	1.8	9.988E-01	7.20	-3.144E-03	4.530E 02	2.153E 02	-9.581E-02	-3.803E-02
5.200	0.0	1.7	9.984E-01	7.19	-3.162E-03	4.529E 02	2.150E 02	-9.638E-02	-4.553E-02
5.300	0.0	1.7	9.988E-01	7.19	-3.217E-03	4.531E 02	2.151E 02	-9.806E-02	-4.501E-02
5.400	0.0	1.6	9.988E-01	7.19	-3.343E-03	4.531E 02	2.152E 02	-1.019E-01	-4.501E-02
5.500	0.0	1.6	9.950E-01	7.18	-1.477E-03	4.534E 02	2.152E 02	-9.610E-02	-3.780E-02
5.600	0.0	1.7	9.990E-01	7.18	-1.360E-03	4.531E 02	2.185E 02	-9.812E-02	-4.144E-02
5.700	0.0	1.8	9.982E-01	7.18	-3.114E-03	4.528E 02	2.150E 02	-9.452E-02	-4.648E-02
5.800	0.0	1.8	9.984E-01	7.18	-1.390E-03	4.529E 02	2.150E 02	-9.542E-02	-4.236E-02
5.900	0.0	1.8	9.989E-01	7.19	-1.472E-03	4.531E 02	2.150E 02	-9.956E-02	-4.486E-02
6.000	0.0	1.8	9.9578E-01	7.19	-3.341E-03	4.526E 02	2.153E 02	-1.018E-01	-4.665E-02
6.100	0.0	1.8	9.974E-01	7.20	-3.042E-03	4.524E 02	2.154E 02	-9.272E-02	-3.613E-02
6.200	0.0	1.8	9.9578E-01	7.21	-3.175E-03	4.526E 02	2.157E 02	-9.677E-02	-3.934E-02
6.300	0.0	1.5	9.977E-01	7.21	-2.545E-03	4.526E 02	2.157E 02	-8.976E-02	-3.678E-02
6.400	0.0	1.5	9.9576E-01	7.21	-1.833E-03	4.525E 02	2.157E 02	-9.701E-02	-3.202E-02
6.500	0.0	1.8	9.9578E-01	7.21	-2.511E-03	4.526E 02	2.158E 02	-8.874E-02	-3.656E-02
6.600	0.0	1.7	9.982E-01	7.21	-3.206E-03	4.528E 02	2.155E 02	-9.773E-02	-3.509E-02
6.700	0.0	1.8	9.9581E-01	7.20	-2.931E-03	4.527E 02	2.155E 02	-8.933E-02	-3.836E-02
6.800	0.0	1.8	9.979E-01	7.20	-3.146E-03	4.527E 02	2.155E 02	-9.550E-02	-4.305E-02
6.900	0.0	1.5	9.9576E-01	7.20	-3.184E-03	4.525E 02	2.154E 02	-9.703E-02	-4.305E-02
7.000	0.0	1.7	9.986E-01	7.20	-2.532E-03	4.530E 02	2.154E 02	-8.937E-02	-3.992E-02
7.100	0.0	1.7	9.989E-01	7.20	-3.066E-03	4.531E 02	2.156E 02	-9.344E-02	-4.011E-02
7.200	0.0	1.7	9.9577E-01	7.20	-1.261E-03	4.526E 02	2.155E 02	-9.736E-02	-3.842E-02
7.300	0.0	1.5	9.9570E-01	7.19	-1.623E-03	4.522E 02	2.151E 02	-9.011E-02	-4.515E-02
7.400	0.0	1.7	9.988E-01	7.19	-2.575E-03	4.530E 02	2.151E 02	-9.068E-02	-3.636E-02
7.500	0.0	1.8	9.982E-01	7.19	-1.683E-03	4.532E 02	2.152E 02	-9.325E-02	-4.515E-02
7.600	0.0	1.8	9.982E-01	7.20	-3.179E-03	4.528E 02	2.154E 02	-9.688E-02	-4.132E-02
7.700	0.0	1.7	9.976E-01	7.20	-2.589E-03	4.525E 02	2.154E 02	-9.111E-02	-4.092E-02
7.800	0.0	1.8	9.9573E-01	7.21	-3.159E-03	4.524E 02	2.157E 02	-9.751E-02	-3.857E-02
7.900	0.0	1.8	9.973E-01	7.21	-2.992E-03	4.524E 02	2.158E 02	-9.120E-02	-3.609E-02

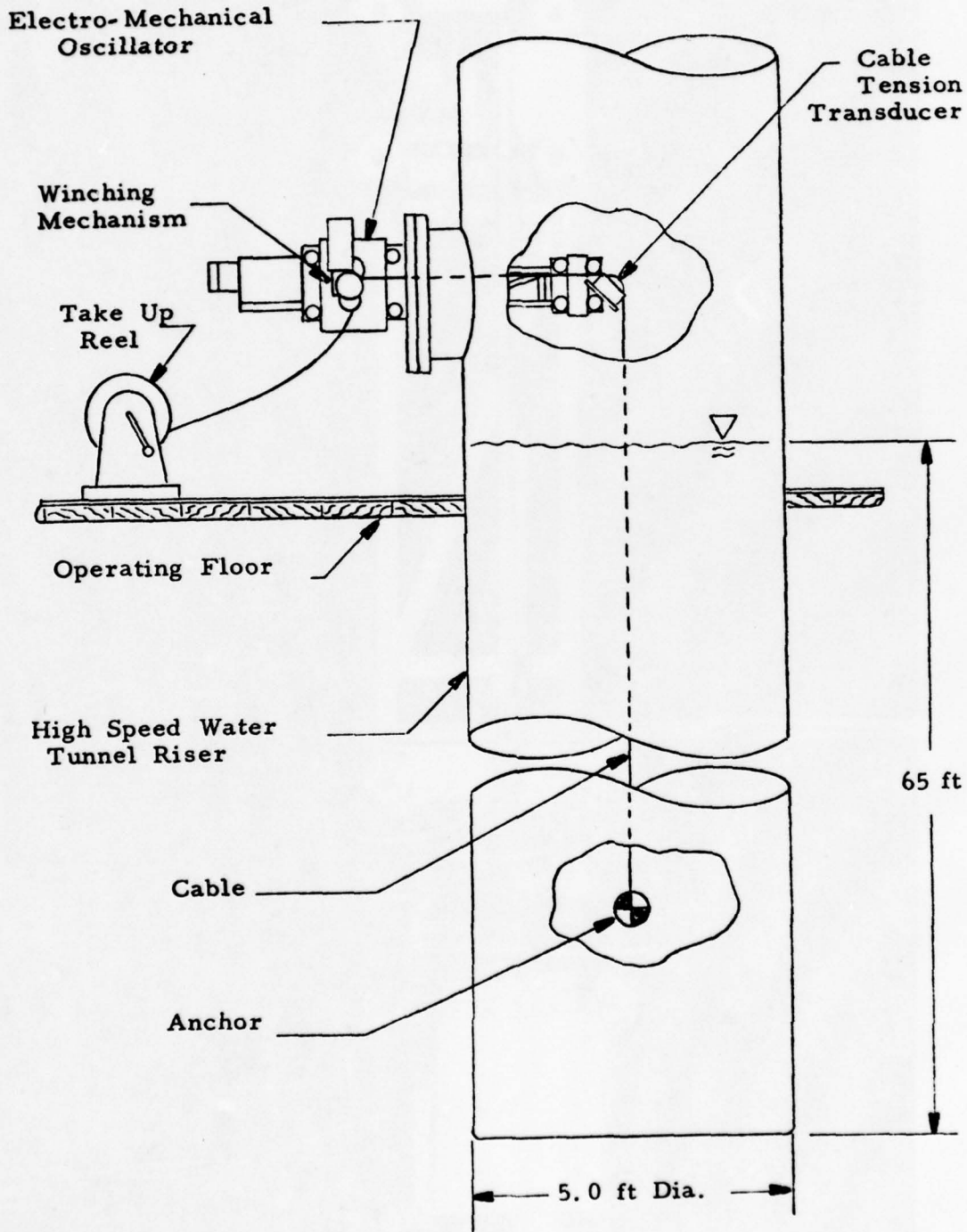

Figure 1. Experimental Arrangement

PRECEDING PAGE BLANK

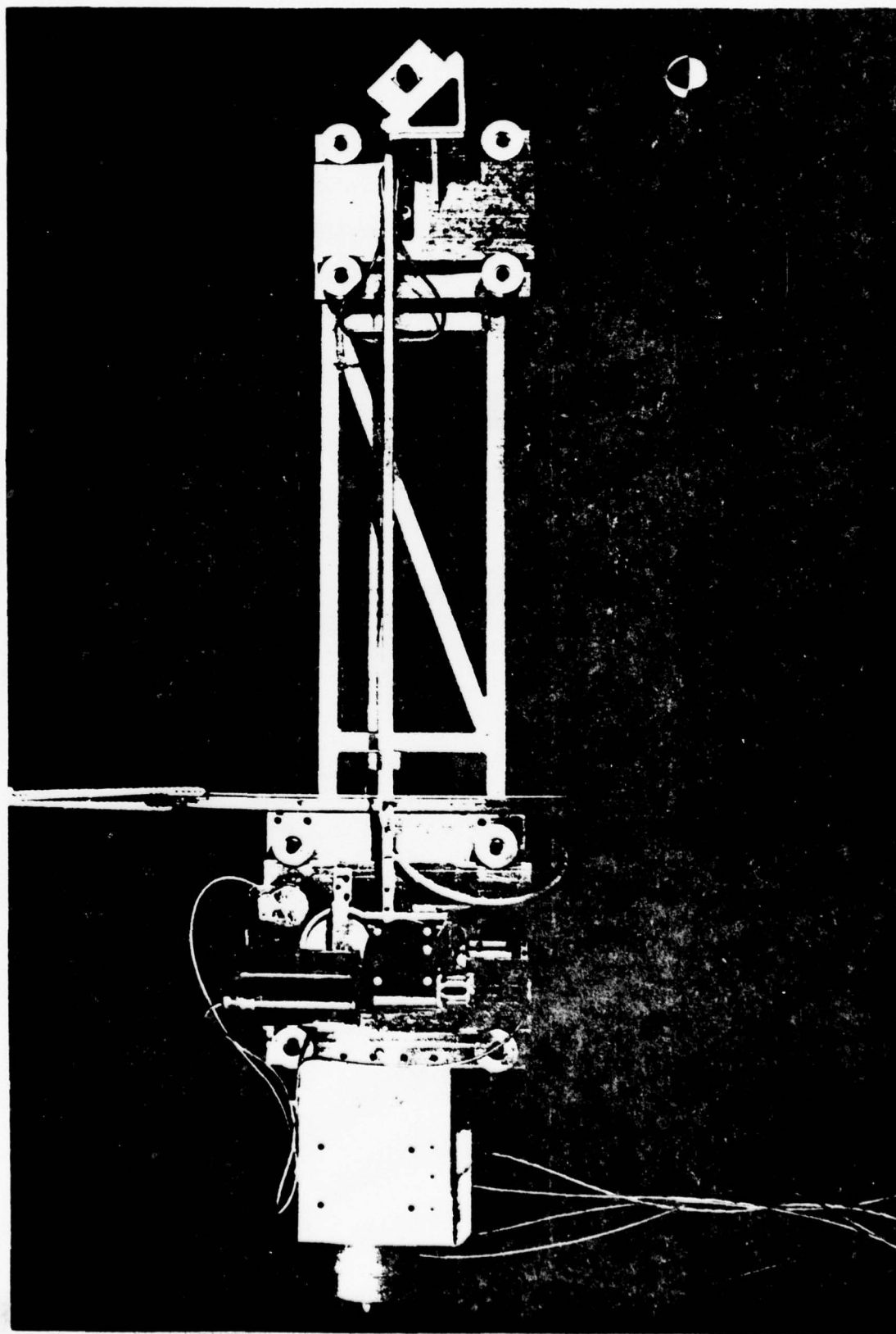

Figure 2. Electro-mechanical oscillator; winch side.

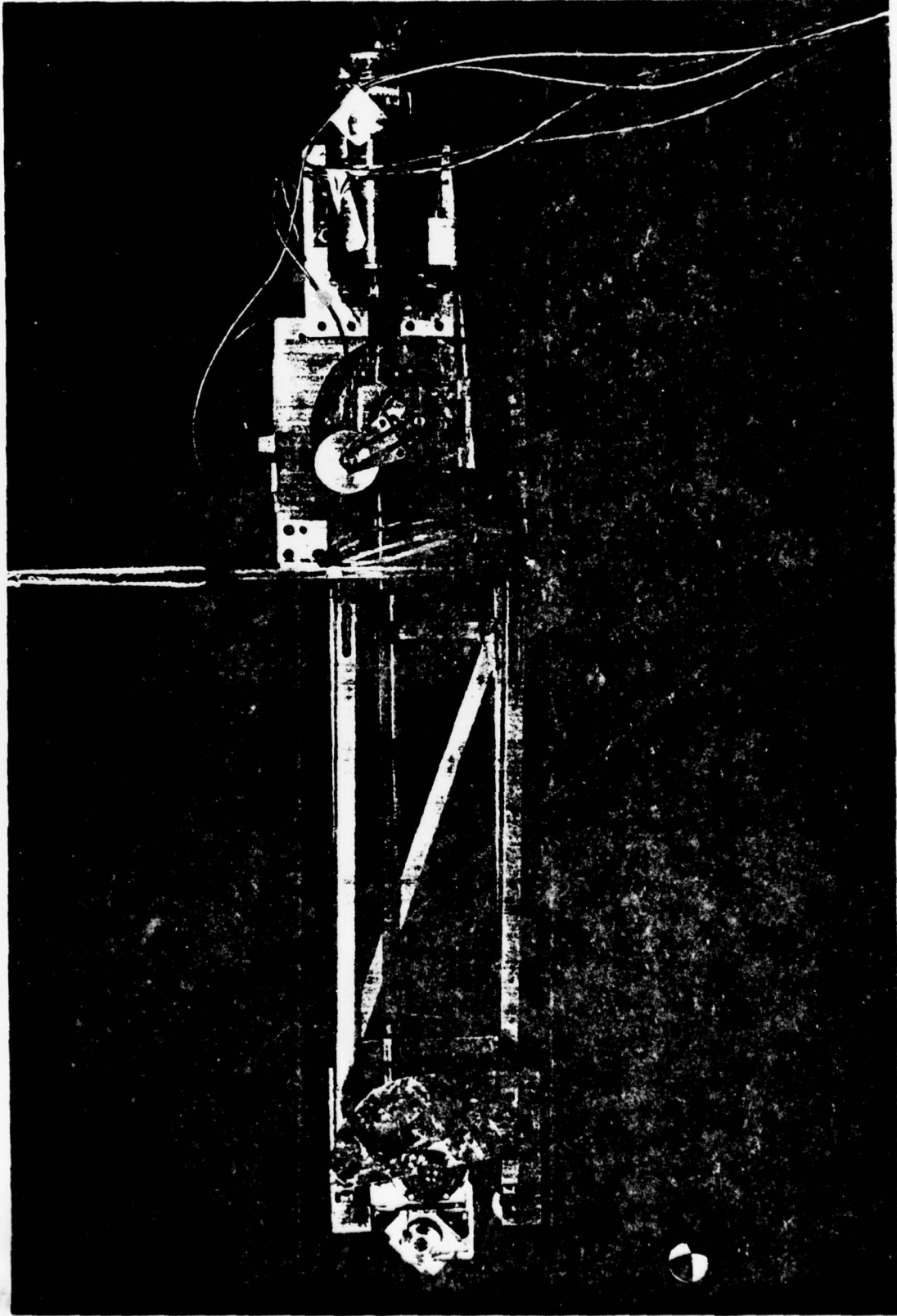
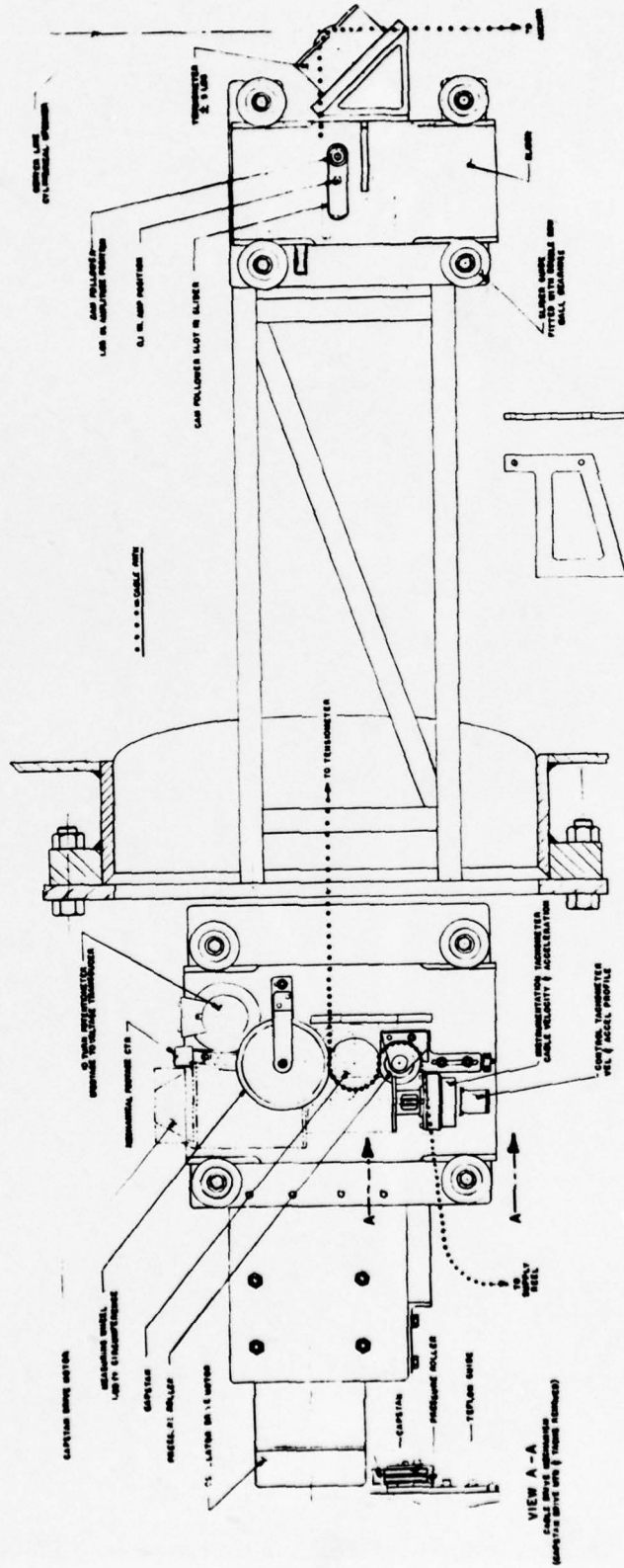

Figure 3. Electro-mechanical oscillator; drive side.



SIDE VIEW
(VERTICAL VIEW)

Figure 4. Arrangement drawing; electro-mechanical oscillator, winch side.

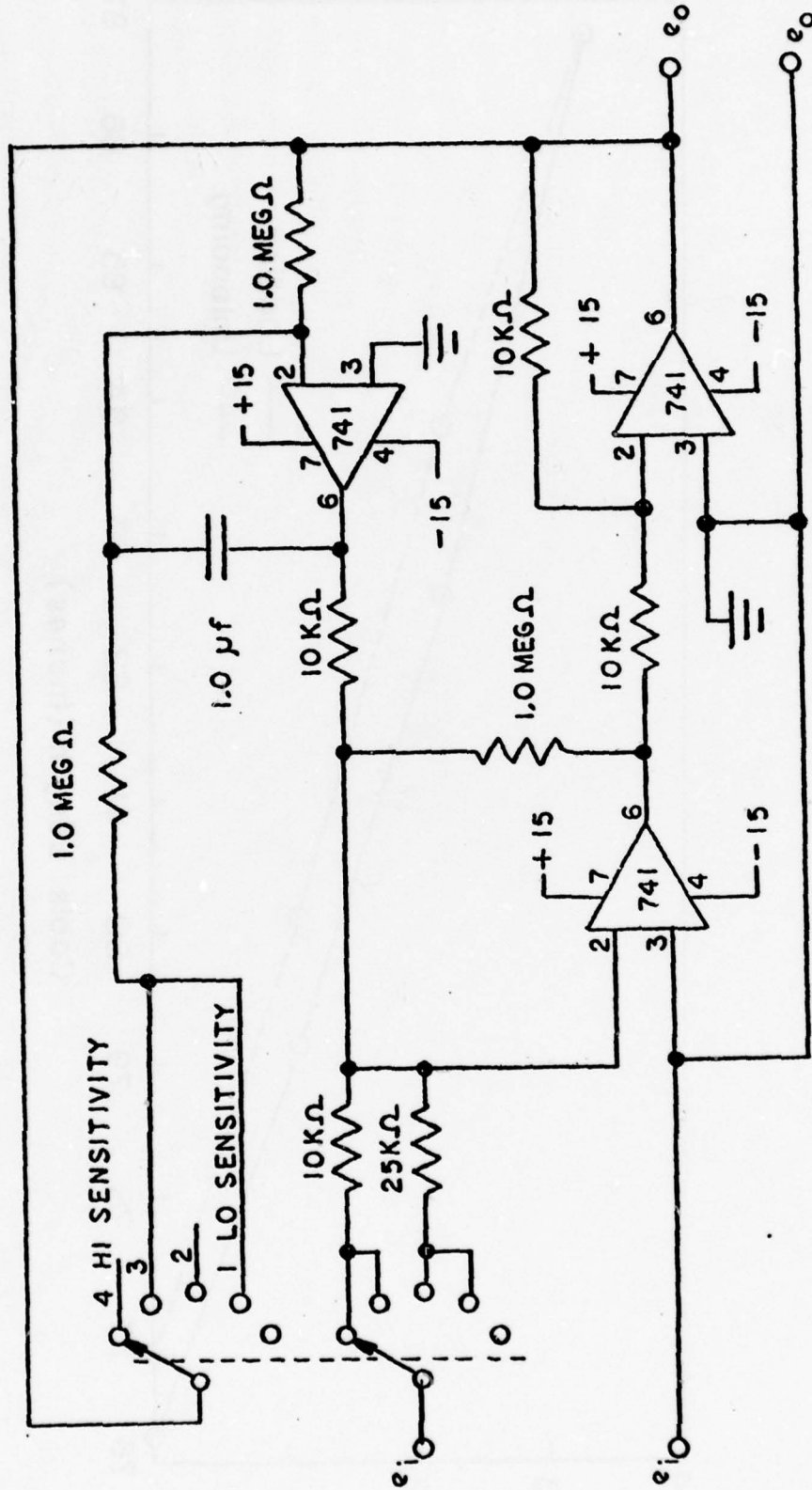

Figure 7. Differentiator Circuit Diagram

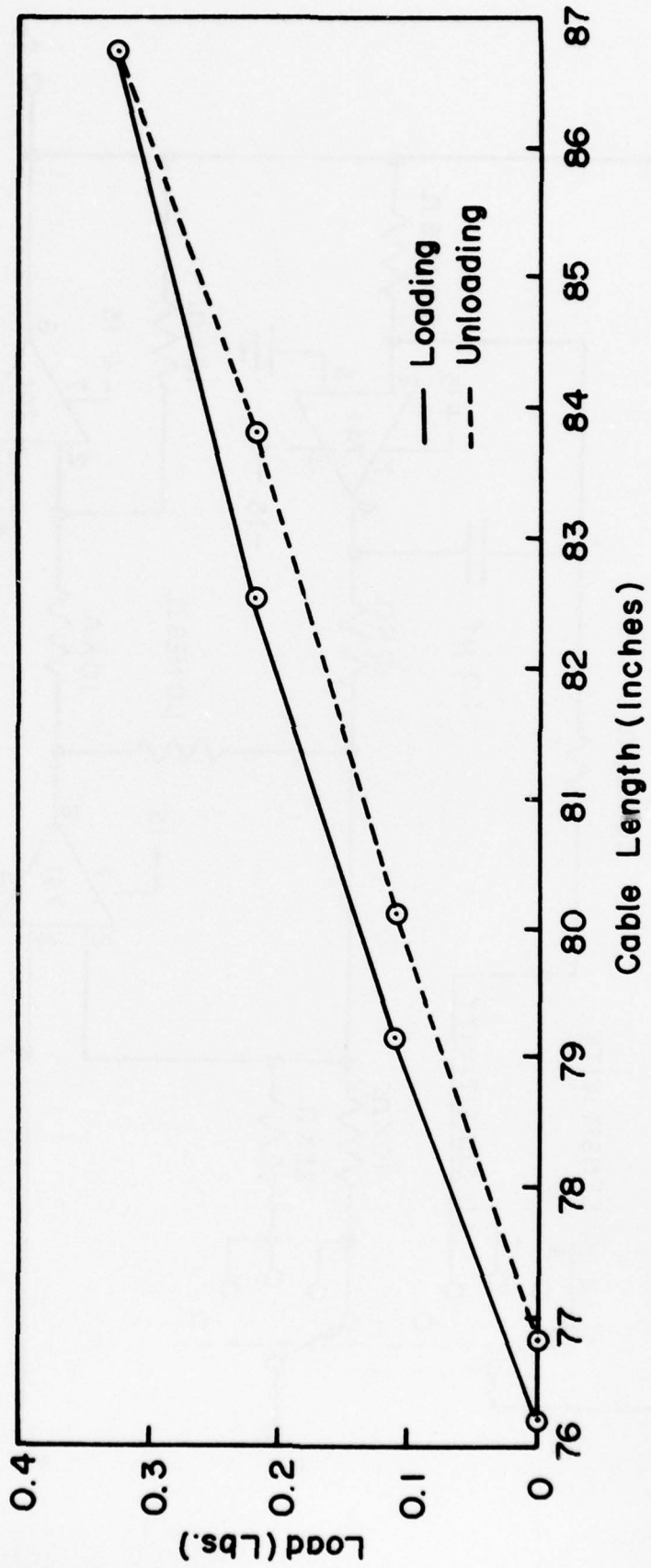

FIGURE 8. ELASTIC CHARACTERISTICS OF SOLID RUBBER CABLE

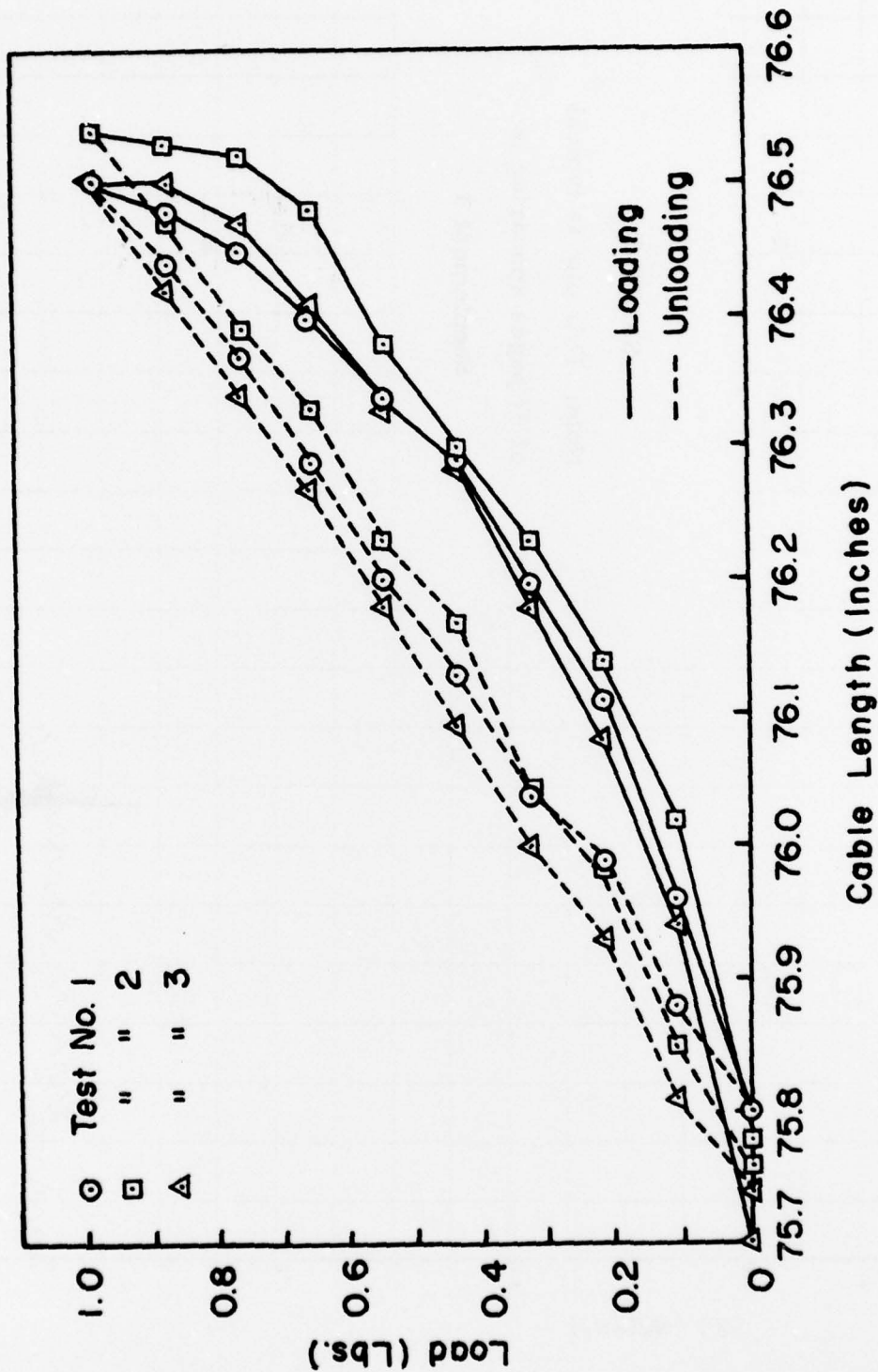

FIGURE 9. ELASTIC CHARACTERISTICS OF NYLON CABLE

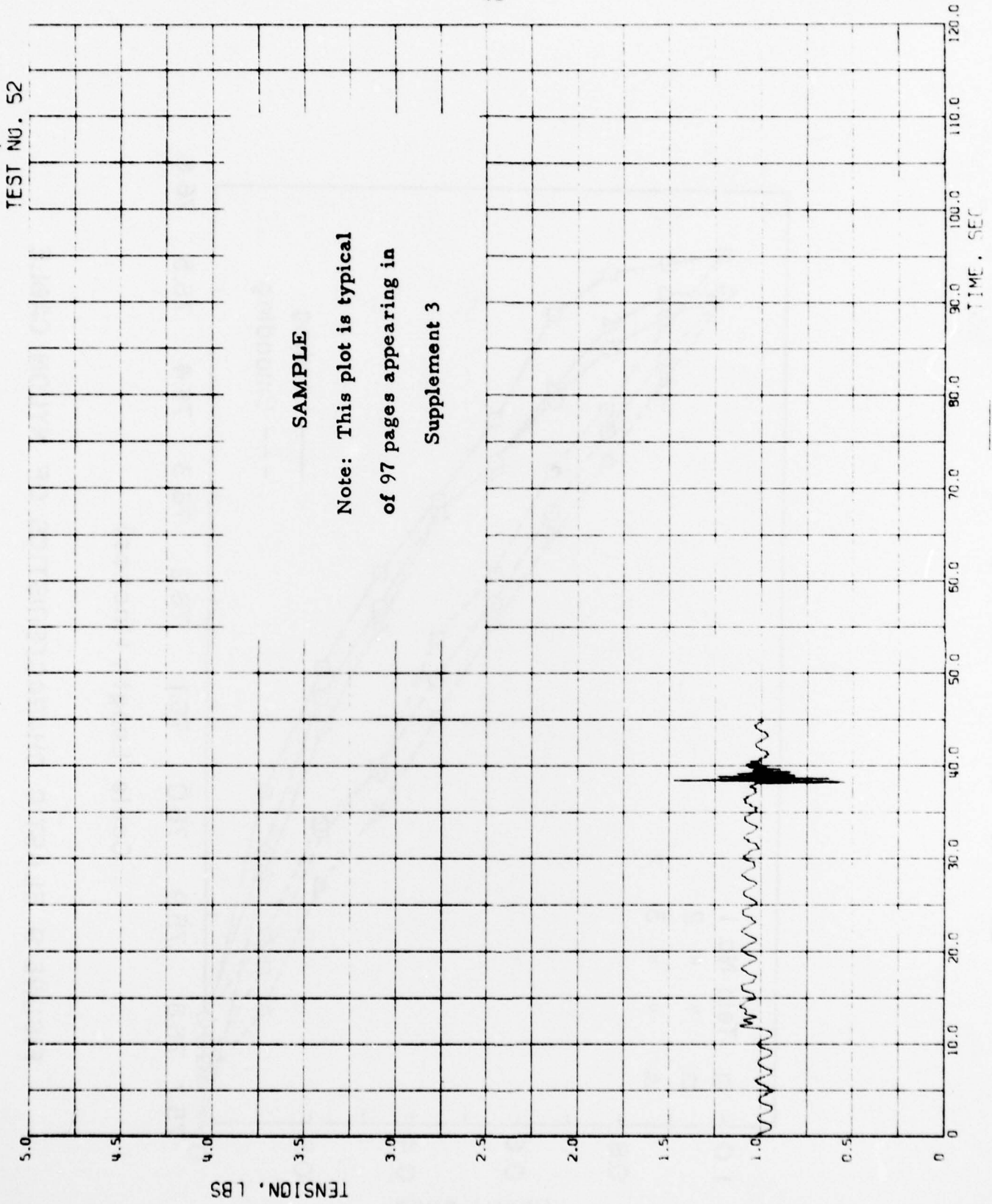

Figure 10. Tension vs. Time ; Test No. 52

APPENDIX I

DATA TAPE FORMAT AND PROGRAM

DATA TAPE FORMAT AND PROGRAM

The Fortran program VLCD1129, which follows, reads a tape (CBL 21 or CBL 22) and data cards with test parameters, processes the data, prints the table "Experimental Data" and plots tension vs. time for each test. The program requires two subroutines which are included and calls several CIT routines for the IBM 370. The program includes constants which convert ADC words on the tape to voltages and voltages to English units and English units to metric units.

The program proceeds test by test. To begin a test, lines are counted so that a heading can be put at the top of each page and a data card is read for:

IREP	GALCIT HSWT report number, which is 1129
ITEST	Test number
ICM	Cable material code Nylon = 1 Rubber = 2
IDIR	Direction code Pay-out = 1 Reel-in = 2 Siene = static = 3
ACC	Acceleration in ft/sec ²
VEL	Velocity in ft/sec
DEC	Deceleration in ft/sec ²
NREC	Number of records or run time in sec as each record contains 1 second of data in real time
RIL	Initial length in ft.
FL	Final length in ft.

MODE	Mode code Dynamic = 1 Static = 2
AMP	Amplitude in inches
FREQ	Frequency in Hz
ID	Identification number
RKV	KV, velocity calibration factor
RKA	KA, acceleration calibration factor

The value of IREP is tested to determine if this card has values for DELTAT, NINT, and NAVE. If it has, CIT routine XBACK is called to reread the data card with

DELTAT	$\Delta T \geq .005$
NINT	$1/\Delta T$
NAVE	$1000 * \Delta T$

Then the next data card is read with the identification and parameters for a test.

The first record from a file (a file corresponds to a test) on magnetic tape is read using CIT routine - 370 READRC (IDATA, NB), where INTEGER * 2 IDATA (6000) is the array where the retrieved record will be stored and NB is the length of the record read in bytes. The tape was created on a Hewlett Packard Model 7970E magnetic tape with 1 record = 6000 words. In the IBM system one of these words equals 2 bytes and one record contains 12000 bytes. This first record on a file contains:

IDATA(1)	=	ID	Identification number
IDATA(2)	=	NREC	Number of records on run time in sec.
IDATA(3)	=	NCHN	Number of channels = 6
IDATA(4)	=	NWRD	Number of words in a record = 6000

Only the first five channels are used. On all but the first record on a file, the first channel corresponds to time, the second to length, the third to oscillating angle, the fourth to acceleration, and the fifth to velocity.

Each record subsequent to the first is read and the data is averaged according to the value of ΔT which has been selected. This averaged data is converted from ADC words into voltages and then into English and metric units. The data is printed in a table. The next record is read until the end of file is reached. Then a plot of tension vs. time is produced on the Calcomp plotter using a CIT routine - 370 XYPLOT.

This program uses two subroutines, HDG1 and GD1129, which are included with the main Fortran program. The first, subroutine HDG1, puts a heading on each page after the first for each test of "Experimental Data." Plain white paper was used for the plots. Subroutine GD1129 draws the axes lines, lines to form a grid, prints the axes titles and scale numbers. Several CIT routines - 370 were used in this subroutine.

**THIS PAGE IS BEST QUALITY PRACTICES
FROM COPY FURNISHED TO DDC**

```

C VLOC1129
C 2/6/78
C 3/3/78
C 3/8/78
C
C THIS IS THE FINAL VERSION.
C CHANGES HAVE BEEN MADE TO THE CONSTANTS AND IN THE EQUATIONS
C TO CHANGE VOLTAGES INTO ENGLISH UNITS.
C
C
C GALCIT REPORT HSWT-1129
C M.O. 97683
C THIS PROGRAM IS TO READ A TAPE ( COL21 OR COL22 ),
C PROCESS THE DATA, AND PRINT
C NEARBY DATA.
C FOR PROPERLY DEFINED VALUES OF DELTA I
C WITH DELTA Y GREATER THAN OR EQUAL TO .005
C PLOT TENSION, LRS, VS TIME, SEC.
C THIS PROGRAM REQUIRES SUBROUTINE WOC1 AND SUBROUTINE G01129
C COMMON / SHEL, IESSI, ICK, IDIR, ACC, VEL, DEC, RI, SIL, EL, MODF, AMP, FREQ,
C IIO, IREC, PKV, PKA
C IIFGEP, IDATA(5000)
C REAL JDATA(1000)
C DIMENSION IC(5), VC(5)
C DIMENSION YPLOT(24000), TIME(24000)
C DIMENSION JOC(13)
C DATA DDC/0.,0.,0.,/
C DATA NCHN, IWRD / -5, 5000 /
C DATA DT/3., 14159 /
C
C CONSTANT TO CONVERT ACC WORDS INTO VOLTAGES
C DT=1./3276.8
C
C CONSTANTS TO BE USED IN CONVERTING VOLTAGES INTO ENGLISH UNITS
C DATA PKT, PKX, PKO / -1.2933, 15.718, 89.493 /
C DATA PKI, PKY, PKC / -1.2114, 15.718, 89.493 /
C
C CONSTANTS TO CONVERT ENGLISH UNITS INTO METRIC UNITS
C
C DATA PLG, FTCH / 453.5924, 30.48 /
C WRITE (2,200)
C FORMAT (14,13,212,3F5.2,14,F5.1,F6.2,12,2F5.2,14,2F6.3)
C 1 10X, INPUT FOR VLOC1129, //
C
C TO BEGIN A TEST
C TO COUNT LINES ON A PAGE
C
C KOUNT=0
C CALL DEFPAD (5)
C
C READ A DATA CARD
C
C 12 READ (5,510,END=2000) I2PF, ITEST, YC4, IDIR, ACC, VEL, DEC, NREC, RI, FL,
C MODE, AMP, FREQ, IIO, PKV, PKA
C 510 FORMAT (14,13,212,3F5.2,14,F5.1,F6.2,12,2F5.2,14,2F6.3)

```

```

C TEST TO SEE IF DATA CARD READ HAS DELTA T
C IF (IOPF.EQ.1129) GO TO 17
C
C REFAD DATA CARD AS THIS IS A CARD WITH DELTA T AND
C NINT=L/DELTA T
C NAVE=1000*DELTA T
C CALL XBACK
C
500 P=5000 DELTA T=NINT*NAVE
C FORMAT (10X,F10.0,2I10)
C
C WRITE DELTA T, NINT, NAVE
C
C
C WRITE (2,210) DELTA T, NINT, NAVE
210 FORMAT (10X,DELTA T=F10.2/
1 10X,NINT=L/DELTA T=L5/
2 10X,NAVE=1000*DELTA T=L5//)
C
C N=L/NAVE
C GO TO 12
C
C DATA CARD READ HAS IDENTIFICATION AND PARAMETERS FOR A TEST
C
C WRITE THE IDENTIFICATION AND PARAMETERS FOR A TEST ON A CHECK LIST
C
17 WRITE (2,220)
220 FORMAT (10X, ITEST, ICH, IDIR, ACC, VEL, DEC, NREC, RIL, FL, MODE, AMP, FREQ,
1 10X, PKV, PKA //)
C
C WRITE (2,230) ITEST, ICH, IDIR, ACC, VEL, DEC, NREC, RIL, FL, MODE, AMP,
1 FREQ, ID, PKV, PKA
230 FORMAT (10X, ITEST, ICH, IDIR, ACC, VEL, DEC, NREC, RIL, FL, MODE, AMP,
1 FREQ, ID, PKV, PKA //)
C
C READ THE FIRST RECORD FROM A FILE (TEST) ON MAG TAPE
C
C CALL READPC(IDATA,NB)
C WRITE (2,250) ITEST, ID, NB
250 FORMAT (10X, ITEST=L, ID=L, NB=L)
C
C TEST THE AGREEMENT OF THE ID DATA FROM CARDS AND TAPE
C
C IF (ID.NE.IDATA(1)) GO TO 900
C IF (NREC.NE.IDATA(2)) GO TO 910
C IF (NCH.NE.IDATA(3)) GO TO 920
C IF (NWRD.NE.IDATA(4)) GO TO 930
C
C DRAW GRID WITH THE AXES
C PRINT AYS TITLES, SCALE NUMBERS, AND TEST NUMBER
C
C CALL GO1129
C N=L/NAVE
C
C WRITE THE HEADING FOR THE FIRST PAGE OF TABLE
C
C
C CALL HDG1
C KOUNT=L/NAVE+23
C

```

```

C S UP A COUNTER TO SERVE AS A TIME BASE
C ICOUNT=0
C READ, AVERAGE, CALCULATE, AND WRITE TABLE FOR ALL BUT FIRST RECORD
C IN A FILE (TEST)
C
C DO 100 I=1, NREC
CALL READPCDATA(NB)
WRITE (2,250) I,TEST,10,WH
10 JSLOT=0
DO 20 J=1, NINT
C THIS PROGRAM USES THE FIRST FIVE OF THE SIX CHANNELS
C
C DO 20 K=1,5
XX=0
DO 25 L=1, NAVE
XX=XX+ICDATA(I,J=1,2,3,4,5,6,7,8,9,10,11,12,13,14,15)
25 CONTINUE
JSLOT=JSLOT+1
ICDATA(JSLOT)=XX/NAVE
20 CONTINUE
J=J+1
C CONVERT AVERAGED DATA, ADC WORDS, INTO VOLTAGES
C
C DO 35 K=1,5
IC(K)=J*K-1
VC(K)=P1*ICDATA(IC(K))
35 CONTINUE
C CONVERT VOLTAGES INTO ENGLISH UNITS
C AND APPLY CORRECTIONS OF MARCH 8, 1978
C BY AND RX ARE PROVIDED AS INPUT
C
X=XX*VC(12)
DANGL=DANG*VC(13)
A=XA*VC(14)
V=VX*VC(15)
DAR=DANGL/57.294
T=DT*VC(11)-.0563
F=(.001654/12.)*SCOS(DAR)*12.*PI*FREQ)*2
T=T-F
C TO CONVERT ENGLISH UNITS INTO METRIC UNITS
C
T=PLRG*T
X=X*EICM*V
A=A*EFCM*V
V=V*EICM*V
COUNT=ICOUNT/ICOUNT/NINT
IF (COUNT .GT. 0.) GO TO 40
RCO=COUNT
PRINT=0
C
C PRINT DATA FOR RCOT=0
C

```

THIS PAGE IS BEST QUALITY PRACTICABLE
FROM COPY FURNISHED TO DDG

```

500      WRITE (A,500)      RCDI, RUNI, DANGL, I, X, V, A, IM, XM, VM, AM
      FORMAT (T4, P(0PF0, 3) * F9.1, P(13, 3, 0PF0, 2, 6(1P(13, 3))
      KOUNT=KOUNT+1
      GO TO 50
C
C      START RUN TIME COUNT, PRINT, WHEN TACHOMETER STARTS
C      AND END RUN TIME WHEN IT STOPS
C
50      CONTINUE
      ARSVARS(V)
      IF (ABSV .LE. 0.025) FLIP=0.
      IF (ARSV .GT. 0.025) FLIP=1.
      IF (FLIP .EQ. 0.) GO TO 50
      BASE=COUNT
      CONTINUE
C
C      CALCULATE SUBSEQUENT VALUES OF RCDI AND RUNI
C
      RUNI=ELIP*(ICOUNT-BASE)
      RCDI=COUNT
      IF (KOUNT .EQ. 5) KOUNT=1
      IF (KOUNT .EQ. 1) GO TO 55
      GO TO 58
55      CALL HOGP
      KOUNT=11
C
C      PRINT THE DATA
C
58      WRITE (A,500)      RCDI, RUNI, DANGL, I, X, V, A, IM, XM, VM, AM
      KOUNT=KOUNT+1
      ICOUNT=ICOUNT+1
C
C      STOP VALUES OF TENSION, LBS AND TIME FOR PLOT
C
      IPLC(ICOUNT)=I
      TIME(ICOUNT)=RCDI
      J=J+5
      JTEST=J*5
      IF (J .GT. JTEST) GO TO 100
      GO TO 30
100     CONTINUE
C
C      END OF A FILE
C
      CALL READRCDI(DATA, NR)
      WRITE (P, 250) ITEST, IO, NB
C
C      TEST FOR END OF FILE
C
      IF (NB .NE. 0) GO TO 940
C
C      PLOT TENSIONS, LBS VS TIME, SEC FOR A TEST
C
      CALL XYPLOT(ICOUNT, TIME, I, X, V, A, IM, XM, VM, AM, 1)
      READ NEXT VALUE OF DELTAT AND PARAMETERS FOR NEXT TEST
C
      GO TO 10

```



```

C      C=NONH/RUNG1/IFEST,IC*,IDIP,ACC,VEL,DFC,RT,HIL,FL,WDE,AMP,FREQ,IO
      L=SEC,BX,RY,XA
C      DIMENSION YLINE(25),YLINE(21)
C      DO 10 I=1,25
      YLINE(I)=1.5+.5*(I-1)
10     CONTINUE
      DO 15 I=1,21
      YLINE(I)=.5*(I-1)
15     CONTINUE
C      POINT TIME AXIS TITLE
C
C      CALL SYCSYM (10,42,-44,15,0,TIME,SEC,9,0,0)
      X=XLINE(IJ)
      XF=YLINE(I25)
C
C      DRAW THE TIME AXIS LINE
C
C      DO 20 I=1,2
      Y=XLINE(IJ)+.11*.208
      CALL SYSPLOT(X,Y,3)
      CALL SYSPLOT(XE,Y,2)
      CALL SYSPLOT(XE,Y,3)
20     CONTINUE
C
C      POINT THE FIRST TENSION AXIS SCALE LABEL
C
C      CALL SYCSYM (1,25,0,1,0,1,0,0,1)
C
C      DRAW THE HORIZONTAL GRID LINES AND
      POINT THE TENSION AXIS SCALE NUMBERS
C
C      DO 30 I=1,20
      Y=YLINE(I+1)
C
C      DRAW A HORIZONTAL GRID LINE
C
      CALL SYSPLOT(X,Y,3)
      CALL SYSPLOT(XE,Y,2)
      CALL SYSPLOT (XE,Y,3)
C
C      TEST IF EVEN OR ODD
C
      I2=I/2
      I2=1/2
      IF (I2-I2) .GT. .000001) GO TO 30
C
C      I IS EVEN
C      POINT TENSION AXIS SCALE NUMBER
C
      PRINT I/4
      IF (I .EQ. 20) Y=Y-.01
      CALL PRTNUM(I,24,Y,1,2,0,0,0,(F3,1),0,0)
30     CONTINUE
C
C      PRINT THE PHYSICAL AXIS TITLE
C

```

