

USARTL-TN-33

12 LEVEL II
nu



**IMPLICATIONS OF A SUCTION FUEL SYSTEM ON
THE CONTAMINATION TOLERANCE OF ARMY HELICOPTERS**

AD A 068364

Kent F. Smith
Roger G. Furgurson

April 1979

DDC
RECEIVED
MAY 9 1979
B

DDC FILE COPY

Approved for public release;
distribution unlimited.

Prepared for
APPLIED TECHNOLOGY LABORATORY
U. S. ARMY RESEARCH AND TECHNOLOGY LABORATORIES (AVRADCOM)
Fort Eustis, Va. 23604

79 05 08 014

DISCLAIMERS

The findings in this report are not to be construed as an official Department of the Army position unless so designated by other authorized documents.

When Government drawings, specifications, or other data are used for any purpose other than in connection with a definitely related Government procurement operation, the United States Government thereby incurs no responsibility nor any obligation whatsoever; and the fact that the Government may have formulated, furnished, or in any way supplied the said drawings, specifications, or other data is not to be regarded by implication or otherwise as in any manner licensing the holder or any other person or corporation, or conveying any rights or permission to manufacture, use, or sell any patented invention that may in any way be related thereto.

Trade names cited in this report do not constitute an official endorsement or approval of the use of such commercial hardware or software.

DISPOSITION INSTRUCTIONS

Destroy this report when no longer needed. Do not return it to the originator.

Unclassified

SECURITY CLASSIFICATION OF THIS PAGE (When Data Entered)

REPORT DOCUMENTATION PAGE		READ INSTRUCTIONS BEFORE COMPLETING FORM
1. REPORT NUMBER USARTL-TN-33	2. GOVT ACCESSION NO.	3. RECIPIENT'S CATALOG NUMBER
4. TITLE (and Subtitle) IMPLICATIONS OF A SUCTION FUEL SYSTEM ON THE CONTAMINATION TOLERANCE OF ARMY HELICOPTERS	5. TYPE OF REPORT & PERIOD COVERED Technical Note	
7. AUTHOR(s) Kent F. Smith Roger G. Furgurson	8. CONTRACT OR GRANT NUMBER(s) House Task 78-05	
9. PERFORMING ORGANIZATION NAME AND ADDRESS Applied Technology Laboratory, U.S. Army Research and Technology Laboratories (AVRADCOM) Fort Eustis, Virginia	10. PROGRAM ELEMENT, PROJECT, AREA & WORK UNIT NUMBER 62209A 1L162209AH76 244 EK	
11. CONTROLLING OFFICE NAME AND ADDRESS	12. REPORT DATE April 1979	13. NUMBER OF PAGES 32
14. MONITORING AGENCY NAME & ADDRESS (if different from Controlling Office) 33p.	15. SECURITY CLASS. (of this report) Unclassified	
16. DISTRIBUTION STATEMENT (of this Report) Approved for public release; distribution unlimited.		
17. DISTRIBUTION STATEMENT (of the abstract entered in Block 20, if different from Report)		
18. SUPPLEMENTARY NOTES		
19. KEY WORDS (Continue on reverse side if necessary and identify by block number) Jet fuel Fuel contamination Helicopter fuel system Turbine fuel pump Fuel filtration		
20. ABSTRACT (Continue on reverse side if necessary and identify by block number) Fuel samples obtained from US Army aircraft and from various key points in the fuel logistic chain were analyzed for contaminant quantity and composition. Results were compared to current turbine engine design and qualification specifications. A second part of this investigation addresses the behavior of various sizes of contaminant particles when subjected to a suction-type fuel feed system typical of recently designed Army aircraft. Particle sizes ranging from 420 to 1500 microns were investigated.		

D D C
RECEIVED
 MAY 9 1979
RECEIVED
 B

398,742

AB

TABLE OF CONTENTS

	<u>Page</u>
LIST OF ILLUSTRATIONS.....	4
LIST OF TABLES.....	4
INTRODUCTION.....	5
FUEL SAMPLING TEST.....	6
Background.....	6
Test Procedure.....	6
Results.....	9
Summary.....	11
DYNAMIC FLOW TEST.....	13
Background.....	13
Test Procedure.....	13
Results.....	15
CONCLUSIONS.....	19

ACCESSION for	
NTIS	White Section <input checked="" type="checkbox"/>
DDC	Buff Section <input type="checkbox"/>
UNANNOUNCED	<input type="checkbox"/>
JUSTIFICATION _____	
BY _____	
DISTRIBUTION/AVAILABILITY CODES	
Dist.	AVAIL. and/or SPECIAL
A	

LIST OF ILLUSTRATIONS

<u>Figure</u>		<u>Page</u>
1	Contaminants analysis sequence for JP-4 samples	8
2	Aircraft fuel inlet versus test configuration	14
3	Suction test schematic diagram	16
4	Location of specific contaminant dispersant points	17

LIST OF TABLES

<u>Table</u>		<u>Page</u>
1	Fuel contaminant package for MIL-E-8593A engine component qualification testing	20
2	JP-4 particulate contaminant concentrations at Fort Hood, Texas (Hood Army Air Field)	21
3	JP-4 particulate contaminant concentrations at Fort Bragg, North Carolina (Oak Grove Army Air Field)	22
4	JP-4 particulate contaminant concentrations at Fort Bliss, Texas (Biggs Army Air Field)	23
5	Particulate size, mass and class distribution for Biggs Army Air Field underground storage tank samples	24
6	Particulate size, mass, and class distribution for Biggs Army Air Field refueled aircraft samples	25
7	JP-4 particulate contaminant concentrations for Brave Shield XIV	26
8	JP-4 particulate contaminant concentrations for Reforger	27
9	JP-4 particulate contaminant concentrations for Reforger (estimated)	28
10	JP-4 particulate contaminant concentrations for Brave Shield XV	29
11	JP-4 particulate contaminant concentrations for Brave Shield XV (estimated)	30
12	JP-4 particulate contaminant concentrations for Gallant Crew	31
13	JP-4 particulate contaminant concentrations for Gallant Crew (estimated) ..	32

INTRODUCTION

Contamination of aviation fuels has been an area of great concern to aviators and engine designers alike. At best, the contamination manifests itself in the form of a startup malfunction or power degradation; or at worst, some form of in-flight engine malfunction.

A realistic assessment of the magnitude of this problem in Army aviation today must include a fairly detailed analysis of two specific questions: (1) what is the severity of fuel contamination in today's typical Army field environment? and (2) assuming that contaminated fuel enters the aircraft fuel tank, what is the likelihood that various sizes of solid contaminant will actually be drawn into the aircraft's fuel system and impact engine performance?

This report deals with both questions by conveying the results of two different investigations. The first program attempted to answer the first question by collecting representative fuel samples during both routine and intense Army operational situations. The samples were next subjected to a sequence of analytical procedures to determine the quantity and exact composition of contaminant. Sampling and analyses were performed and documented by the US Army Fuels and Lubricants Research Laboratory (AFLRL).¹ The second question was addressed by a test program in which a UTTAS (BLACK HAWK) suction fuel system was simulated to study the behavior of various contaminant particles under dynamic flow conditions.

¹J. A. Russell, J. D. Tosh, F. M. Newman, M. K. Greenberg, and J. H. Frazar, *Definition of Aviation Turbine Fuel Contamination Under Simulated Combat Conditions*, AFLRL No. 90, U.S. Army Fuels and Lubricants Research Laboratory, San Antonio, Texas, September 1977, AD A047223.

FUEL SAMPLING TEST

BACKGROUND

The purpose of all fuel contamination specification requirements is to minimize the likelihood of fuel-related incidents. Requirements can become more severe and less realistic with time to the extent that qualification criteria may be challenged by either fuel refiners or engine and component manufacturers. This process of challenge and review of requirements often proves beneficial to both industrial and military interests who share a common goal of maximum systems performance at minimum cost.

The fuel contaminant package (Table 1) for aviation gas turbine engine component and systems qualification as prescribed in References 2 and 3 has come under some criticism for being unrealistically severe. Fuel pump vendors have pointed out, for example, that crushed quartz in various particle sizes was added to this package in apparent response to the Korean wartime environment. At that time, fuel was sometimes stored in ground depressions covered with a flexible plastic liner. As this is no longer practiced, vendors reason that the crushed quartz is unrealistically severe. However, this criticism would not be grounds for relaxing contaminant size/type criteria since qualification testing must be severe to provide an accelerated representation of component life expectancy. A more pertinent and significant question is whether or not the specified contaminant package is representative of the type of contaminant encountered in Army aviation field operations. The fuel sampling test program was structured to answer this question.

TEST PROCEDURE

During May 1976 through March 1977, 291 samples of fuel from seven diverse Army aviation activities were collected and analyzed. One of these locations (Fort Hood, Texas) may be considered as being typical of peacetime operations, while others were at sites of intense training operations closely approaching a wartime situation. Samples were also obtained at key points in the fuel logistic chain; e.g., underground storage tanks, tank trucks, and rail cars. Fuel samples were obtained from aircraft and fuel supply points participating in the following field exercises held during 1976-1977:

Solid Shield
Brave Shield XIV
Brave Shield XV
Reforged
Gallant Crew

²Military Specification, MIL-E-8593A, *Engines, Aircraft, Turboshaft and Turboprop, General Specification for*, 15 October 1975.

³Military Specification, MIL-E-5007D, *Engines, Aircraft, Turbojet and Turbofan, General Specification for*, 15 October 1973.

The following technique for fuel sample collection was developed and adhered to in all cases:

- Clean around aircraft fuel sump drain to remove all foreign matter.
- Open fuel sample container (525-ml Nalgene linear polyethylene bottle) while in place under sump drain.
- Activate drain as necessary to fill fuel sample bottle.
- When bottle is full, place cap on container while in place under sump drain to avoid inclusion of foreign material.
- Record aircraft registration number, type, sampling point, last aircraft refueling location, type of refueling, and type of mission flown.
- Take sample immediately to AFLRL for analysis.

Each fuel sample was then analyzed sequentially as follows:

Step 1. Visual inspection for a general estimate of the degree and type of contamination.

Step 2. Tyndall Cone - A light-scattering technique for qualitative evaluation of particle size distribution of suspended material to determine the type of filtration required. A light beam is projected into the sample through the bottom of the sample vial. Particle reflectance as seen in a darkened room permits estimation of particle size and degree of contamination.

Step 3. Cascade Filtration - The total fuel sample is filtered vertically through a stacked column of filtered elements of decreasing porosity. For those samples deemed relatively clear, only two porosities, 8- and 0.45-micron, were used; for samples having higher particulate content, stacked filters of 1000-, 500-, 300-, 102-, 52-, 26-, 8-, and 0.45-micron were used. The 8- and 0.45-micron filters were cellulose acetate and the others were nylon mesh.

Step 4. Gravimetric Analysis - The filters were heptane rinsed and dried. The net weight increase of each filter was recorded. This, plus knowledge of each filter's porosity, resulted in mass distribution histogram data for the select particle size differentials.

Step 5. Photomicrographic Analysis - Filter elements were examined under a microscope and those having significant contaminant were photographed at 4X.

Step 6. X-Ray Fluorescence (XRF) Analysis - All filters were subjected to an energy dispersive XRF analysis, a nondestructive technique for elemental assay. Virtually all elements can be quantitatively identified by XRF. The significant elements detected were iron, aluminum, silicon, phosphorus, sulfur, calcium, chromium, titanium, copper, and zinc. From the distribution of these elements, estimation of the mineralogical and metallic makeup can be made, which facilitates confirmation by more sophisticated methods.

Step 7. X-Ray Diffraction. Selected contaminant materials were removed from some of the filters and analyzed by X-ray powder diffractometry. The diffraction patterns were compared to ASTM powder data file standards. Compound composition and crystalline structure were then determined.

Figure 1 presents a flow schematic for the above analysis sequence.

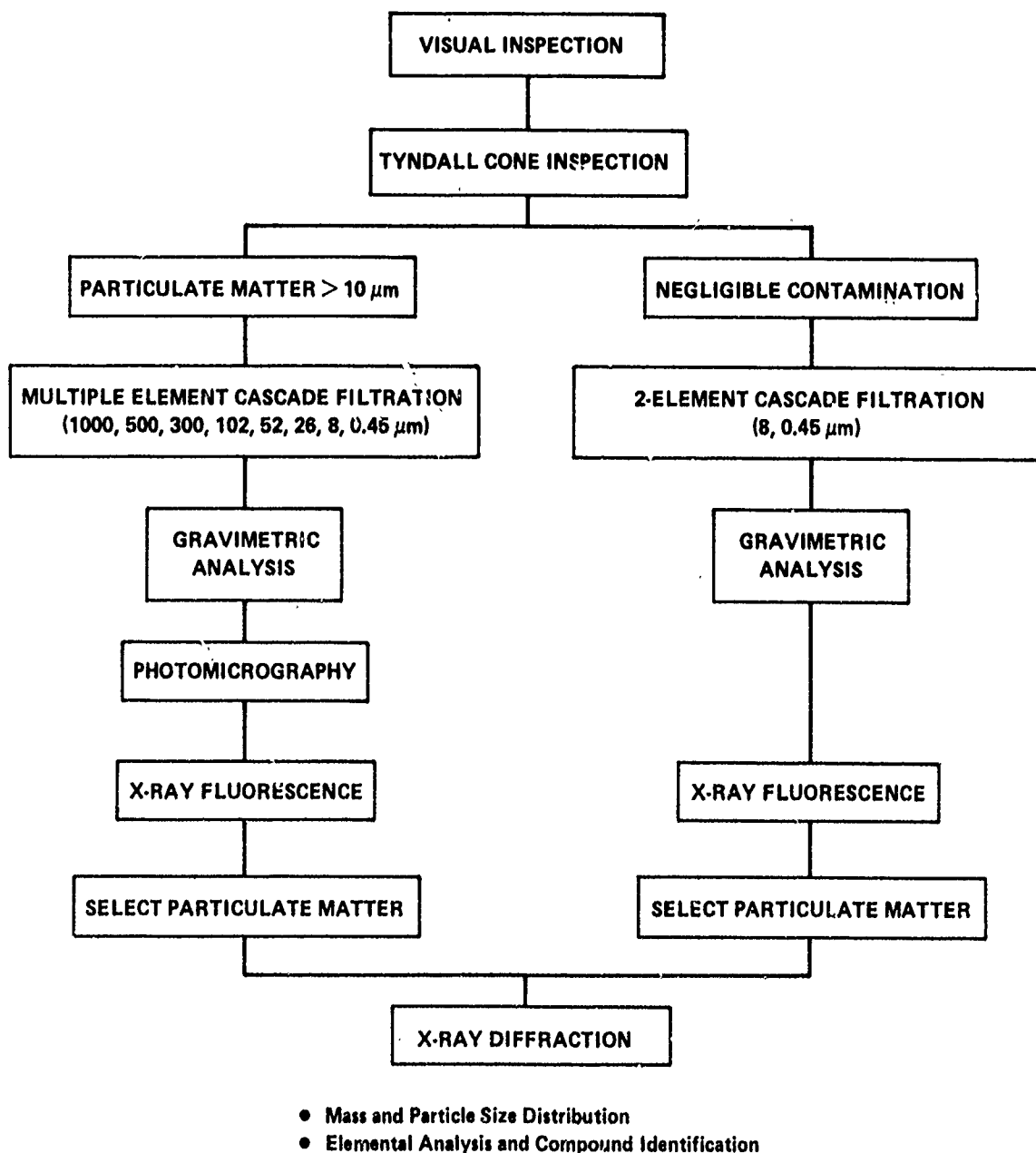

Figure 1. Contaminants analysis sequence for JP-4 samples.

RESULTS

JP-4 particulate contaminants data for the several operational sites are summarized in Tables 2 through 13. Laboratory sample numbers, sample dates, and aircraft/unit identification are self-explanatory. Particulate concentrations (in grams per thousand gallons) have been calculated and reported as the oxides of the metals even though the element is determined by X-ray fluorescence. Reporting all iron as Fe_2O_3 , all silicon as SiO_2 (quartz), all aluminum as Al_2O_3 , and all calcium as CaO is the only possible way to permit comparison of data to specification values.

Numbers in parentheses (30.0, 4.0, and 8.0) at the bottom of certain columns represent the specification levels for iron oxides, silicon dioxide, and "road dust" (see Table 1).

Hood Army Air Field, Fort Hood, Texas (1976)

Prior to participating in scheduled Army field training exercises, AFLRL personnel took 17 fuel drain samples from aircraft at Hood AAF. These aircraft were either used in routine training operations with the Second Armored Division stationed at Fort Hood, or were transient aircraft undergoing periodic maintenance. Visual inspection and subsequent filtration and gravimetric analysis showed contaminant levels (see Table 2) for all samples to be lower than specification levels, so no cascade filtrations were performed. This was intended as a field/lab familiarization exercise as well as to provide initial data.

All aircraft samples were taken at belly sump drain points, since sampling from other points in the aircraft would have entailed disassembly of internal fuel system components and consequent interruption of the air support mission. All sump samples actually represent maximum particulate contamination accumulated between preflight or maintenance sump drain operations.

Oak Grove Army Air Field, Fort Bragg, North Carolina (1976) - Solid Shield

In this first sampling from a field exercise, relatively low contamination was found in 26 samples from active aircraft and 3 samples from nozzle and bladder/sump drains at the fixed fuel point at Oak Grove AAF (see Table 3). For this reason, no cascade filtration was performed.

New Mexico Air National Guard Training Exercise, Biggs Army Air Field (1976)

Three samples in Table 4 (6466, 6476, and 6486) had such high contaminant concentrations that cascade filtration was indicated. Data for this analysis are given in Table 5. These three samples were collected from the Biggs (Fort Bliss) AAF underground fuel storage complex. Samples 6466 and 6476 were obtained with a sampling thief from tanks three and five, approximately 1 inch above each tank bottom. All tanks had been cleaned and filter elements changed in February 1976, approximately 90 to 120 days prior to the AFLRL sampling. Sample 6486 was taken immediately downstream of the filtration system serving tanks three and four jointly. Samples from tanks four and six

(6471, 6481) had far less contaminants as compared to the other samples in Table 5, but still had quite high levels as compared to most aircraft samples. The sample taken immediately downstream of the joint tank 5/6 filtration system (6493, Table 4) showed virtually no contamination.

Contaminant concentrations for the five extreme cases (Table 5) are expressed in g/1000 gallons for consistent comparison to the preceding tables, and particle size distribution in microns has been determined by gravimetric and X-ray fluorescence analyses which give net particulate mass and predominant elements, respectively. Determination of compound class from element distribution was quite straightforward. For sample 6466, iron compounds comprised 99 to 100 percent of the mass down to 300 microns and comprised 80 to 90 percent thereafter to 8 microns. The balance was silicon, and subsequent X-ray diffraction analysis confirmed that all iron was present as Fe_2O_3 or $FeO(OH)$, and all silicon as SiO_2 . The same was true for sample 6486, except that more SiO_2 was present in the 8- to 500-micron range. Sample 6486 had, in addition to iron oxides and quartz, significant amounts of calcium and aluminum. Again, X-ray diffraction confirmed these elements to be present as calcium aluminum silicates ($CaAl_2Si_2O_8$), a clay-like material indigenous to the southwest United States.

Table 6 presents particulate distribution data for the four aircraft having highest contaminant levels from the Fort Bliss (Biggs AAF) operation. No mass distribution data could be obtained for samples 6487 or 6492, since all particulate matter was captured on 8- and 0.45-micron filters and consumed for X-ray diffraction analysis to determine compound class distribution. It is significant that the values for these samples approached specification levels and came from aircraft having recently completed several NOE missions over desert terrain.

Brave Shield XIV (1976)

All samples for Brave Shield XIV were taken at the single fixed refueling point at Yakima Firing Range, Washington. Data are given in Table 7. Again, contaminant levels for 23 samples from aircraft belly drains and 3 samples from refueling trucks were found to be below specification levels. For this reason, no subsequent gravimetric analysis was deemed to be necessary.

Reforger, Germany (1976)

Thirty eight aircraft belly drain samples (see Table 8) were taken at several aircraft deployment positions. In addition, numerous samples were taken upstream and downstream of individual bladder-filtration units and at exit nozzle points. Since one of the points of supply prior to the hardpoint refueling stations was a railroad tank car, it was possible to obtain samples from the tank car itself and after filtration through the discharge filter separator. Sample 6600 shows a total nonferrous oxide level of 16.566. Of this quantity, 15.806 was found to be composed of a silicon compound. This was attributable to a single tuft of inorganic material, and cascade filtration was therefore not required. The source of the tuft remains unknown; it was downstream of the filter separator. It is quite likely that subsequent filtration would have removed this item from the fuel flowstream.

Three aircraft samples (6594, 6603, and 6614) were found to have sufficiently high particulate concentrations to warrant cascade filtration and subsequent X-ray diffraction analysis for compound class. These are given in Table 9. For sample 6594 (AH-1G No. 70-16045), it was found that iron oxide particulates were distributed across the total range of filter porosities. Quartz and calcium silicates took the form of rather fine particles in the 8- to 52-micron range while zinc compounds (likely from paint) were in rather large chips of sizes in excess of 1000 microns. For 6603 (OH-58A No. 71-20497), enormous quantities of iron oxides and zinc compounds of relatively large particle size were found. These were likely from fuel system rust and ingested paint compounds. For sample 6614 (AH-1G No. 71-21031), contamination stemmed both from iron oxides and quartz. The uniform distribution of both contaminants indicates that the source would be both fuel system rust and clay- or sand-like materials ingested into the fuel system during refueling or maintenance operations.

Brave Shield XV, Eglin Air Force Base, Florida (1976)

Thirty aircraft belly drain samples were taken; two samples were from tank trucks used to refuel these same aircraft (see Table 10). In this operation, four individual aircraft (samples 6664, 6665, 6666, and 6667) were found to have significant particulate contamination and were cascade filtered. Data for these four aircraft are given in Table 11. For sample 6664 (OH-58A No. 70-15613), the dominant contaminating material was quartz, the likely source being sand ingested during refueling or maintenance operations. Although contamination was somewhat less for the other three samples, the domination of quartz was still apparent; this was not surprising because of the location of this exercise.

Gallant Crew, Fort Hood, Texas (1977)

Two of the 32 aircraft belly drain samples for this exercise underwent cascade filtration (see Table 12). At least three other samples (6897, 6898, and 6901) had total non-ferrous oxide contamination at a level to warrant cascade filtration, but since no Tyndall Cone effect was observed, this could not be ascertained until after initial filtration. For sample 6895 (CH-47C No. 70-15008), the principal contamination stemmed from both quartz and calcium silicates, indicating a mixture of sand and clay from outside sources (see Table 13). To a lesser degree iron oxides were present, again likely from fuel system rust. Sample 6914 (CH-47C No. 70-15019) had roughly the same relative distribution of quartz, calcium silicates, and iron oxides, although at a considerably lower level. Such clay/sand mixtures are indigenous to the Fort Hood area.

SUMMARY

From the preceding data, it can be seen that the contaminant concentration levels of the vast majority of aircraft sump drain samples were far below the specification particulates, but an appreciable number of aircraft samples (approximately 7 percent) plus numerous points in the refueling systems showed concentrations far exceeding those specified by Table 1. The fact that drain samples taken from operational Army aircraft contained concentrations of the same order as a test contaminant package criticized for its severity

must be placed into proper perspective. These samples were: (1) taken from the lowest point in the aircraft fuel systems, (2) upstream of on-board aircraft fuel filtration elements, (3) cumulative in the sense that most residual particulate matter will settle to the drain area over a period of time, and (4) calculated as oxides of the elements identified (Fe_2O_3 , SiO_2 , Al_2O_3 , CaO) as opposed to costly quantitative analysis required for identification of clay-like compounds. For the above reasons, the data as presented represent a worst possible case with respect to comparison to specification values. Probably the most important fact uncovered by this investigation is that significant quantities of the exact elements and compounds specified in MIL-E-8593A and MIL-E-5007 were, in fact, found in on-board aircraft fuel systems, even though this fuel had been subjected to the extensive upstream filtration prescribed for an Army aviation fuel supply. This would certainly verify the reasonableness of contaminated fuel packages specified by the above military specifications.

DYNAMIC FLOW TEST

BACKGROUND

The most recently designed aircraft for US Army service have incorporated a negative pressure or suction-type fuel feed system from the aircraft tanks to the engine. This system employs an engine-driven fuel pump that draws fuel from the tank, eliminating the requirement for a submerged continuous-operation, tank-mounted boost pump. The negative pressure feed system has come about primarily due to the desire to improve vulnerability and crashworthiness of Army aircraft.

During the same time period that suction fuel system requirements were being established, major changes were being made to the engine design specifications with regard to fuel contamination. These changes resulted in the requirement to qualify engine fuel systems using fuel contaminated with particles of crushed quartz up to 1500 microns in size (Table 1). Previous specifications had called for particle sizes up to 420 microns.

In an effort to minimize pressure drop, no fuel filtration is provided between the fuel tank and the first stage of pumping (the negative pressure portion of the system). The first stage of fuel pumping is exposed to unfiltered fuel that may contain particles as large as 1500 microns. The logical question arose as to whether these larger particles would actually be entrained in the fuel and be drawn up through the aircraft fuel lines into the engine-driven pumps, in view of the very low flow velocities characteristic of a suction fuel system. This dynamic flow test program was therefore devised to answer this question.

TEST PROCEDURE

The primary objective of this testing was to determine the behavior of particles of contaminant in JP-4 fuel under dynamic flow conditions simulating the inlet area of a typical aircraft suction fuel system.

It would have been desirable to use actual aircraft fuel system components at the fuel inlet, but this hardware was not available. The fuel inlet area was therefore fabricated so as to be representative of the actual hardware in terms of general configuration, inlet zone opening, and final tubing size. No attempt was made to exactly duplicate the internal configuration of the inlet housing such as flapper valves, negative "g" valves, or check valves. Figure 2 shows a comparison between typical aircraft hardware and the test configuration. It was recognized that flow within the actual hardware would result in local disturbances and areas of increased velocity which would probably not exist in the simplified test hardware. However, it was felt that these differences would not affect the overall behavior of any particles as long as the flow area at the top of the inlet chamber (line to the engine) was duplicated.

In order to simulate the entire range of flow conditions which might exist in an operational vehicle, fuel flow rates corresponding to three flight conditions were

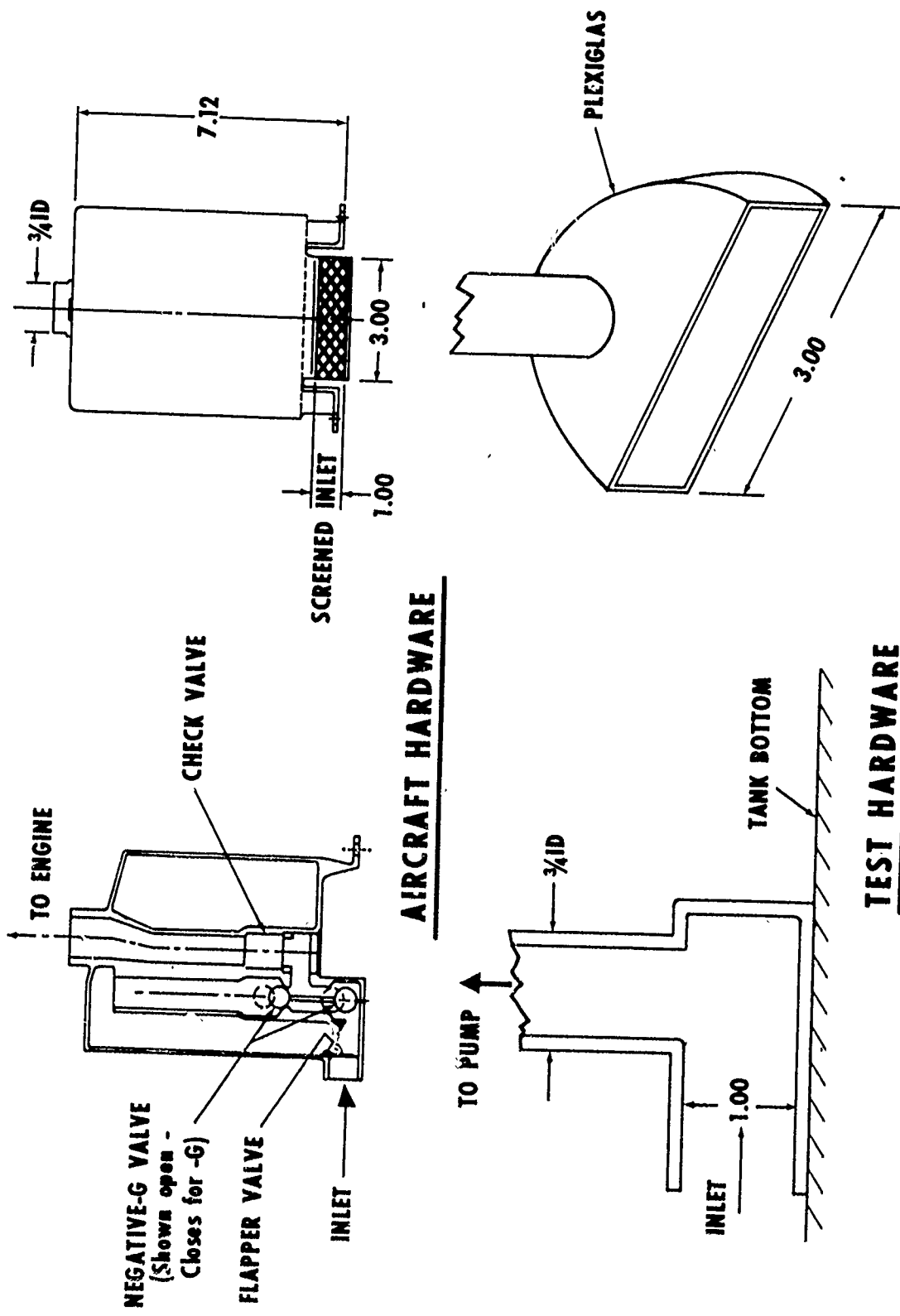

Figure 2. Aircraft fuel inlet versus test configuration.

calculated: engine idle; maximum power (IRP at sea level); and maximum power-cross-feed, where both engines are feeding from a common line. This resulted in the following fuel feed flow rates and flow velocities in the 3/4-inch fuel line to the engine:

<u>Power Condition</u>	<u>Fuel Flow (gpm)</u>	<u>Flow Velocity (fps)</u>
Engine idle	0.25	0.18
Maximum power	1.92	1.40
Maximum power-cross-feed	3.84	2.80

Since the primary concern of the investigation was the behavior of larger particles, it was decided to start with crushed quartz near 1500 microns and to determine how readily their movement through the inlet could be detected. The test tank, fuel inlet chamber, and line to the fuel pump were fabricated from clear Plexiglas to allow visual observation of particles to the extent possible.* A fine filter was installed at the pump exit with the idea that filter inspection would be necessary to obtain a quantitative indication of the particles being drawn from the test tank. As it turned out, all the particles of interest (>420 microns) could readily be observed through the clear tubing. Figure 3 schematically shows the layout of the test equipment.

RESULTS

The test rig was first flow-checked and the flowmeter calibrated. Contaminant particle identification runs were then made by introducing particles at the pump inlet and then examining the test filter for the presence of particles. The contaminant was available in the size ranges as called out in Table 1. The larger particles (1000 to 1500 microns) were introduced first and could readily be observed on the filter surface. Successively smaller particles were trapped on the filter and it was determined that good visual identification could be made down to 150 microns. Smaller particles were not checked.

The fuel tank was then filled approximately two-thirds full with fuel and the system was readied for the suction tests. The first test series was run with the 1000- to 1500-micron particles. The particles were introduced at the fuel surface over the inlet pipe (see Figure 3), settling to the tank bottom immediately in front of the simulated inlet fixture. None of the particles would move toward the inlet even at the highest flow condition. (At this point, the behavior of the individual particles could be easily observed.) The particles were then introduced while the fuel was being agitated with the electric stirring device. Still, none of the particles would flow in the direction of the inlet area.

A device was then fashioned to introduce the contaminant directly into the inlet area. This consisted of a small scoop which would be positioned as required. Figure 4 schematically shows the locations where the contaminant was introduced. When placed in Location No. 1 with the fuel flow at the maximum condition, simulating two engines drawing from one inlet, the particles still failed to be drawn up into the inlet pipe. When placed in Location No. 2, the particles were drawn into the pipe and travelled to

*Any use of materials such as Plexiglas for fuel lines requires very careful attention to proper grounding techniques to dissipate static electric charges.

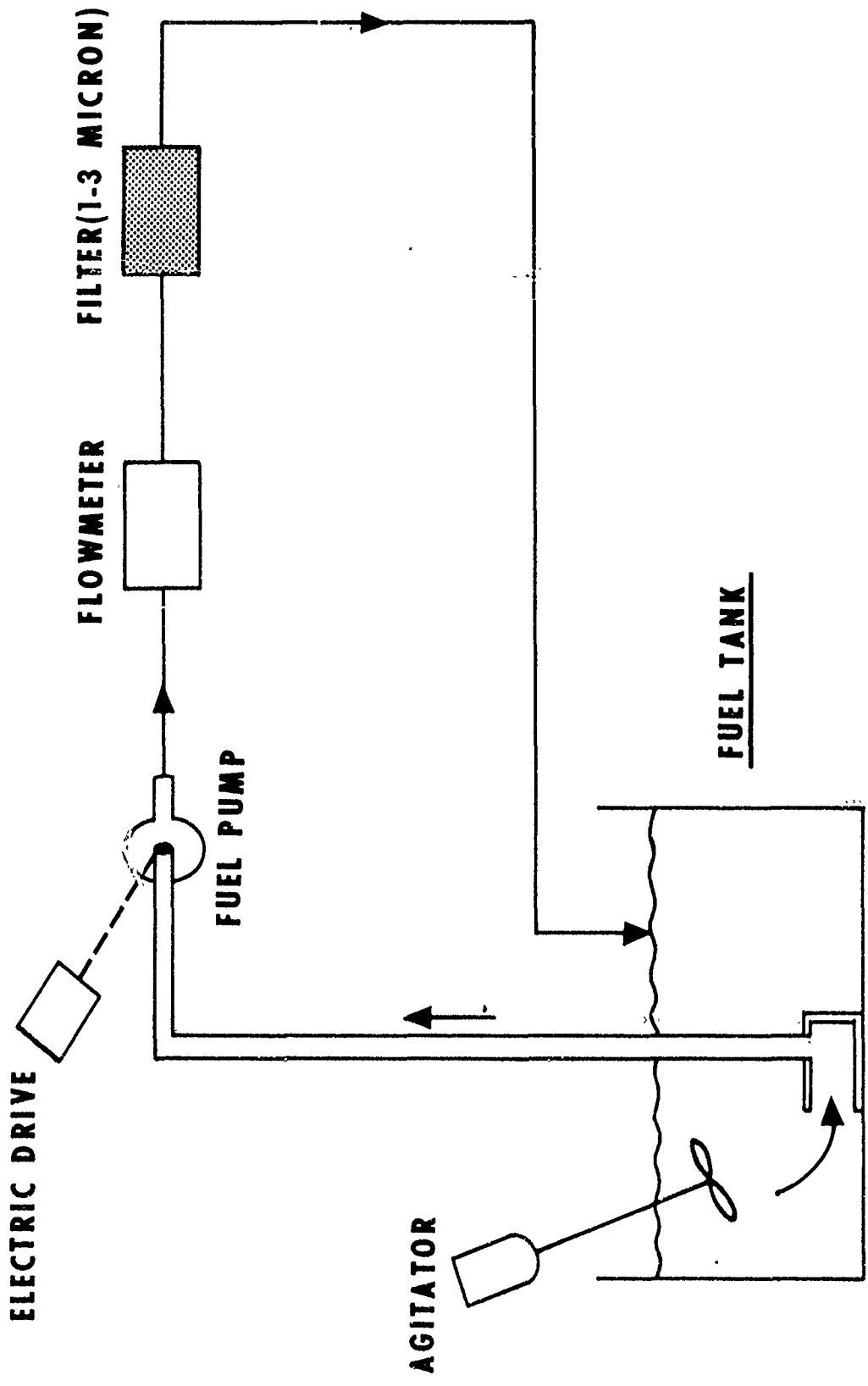

Figure 3. Suction test schematic diagram.

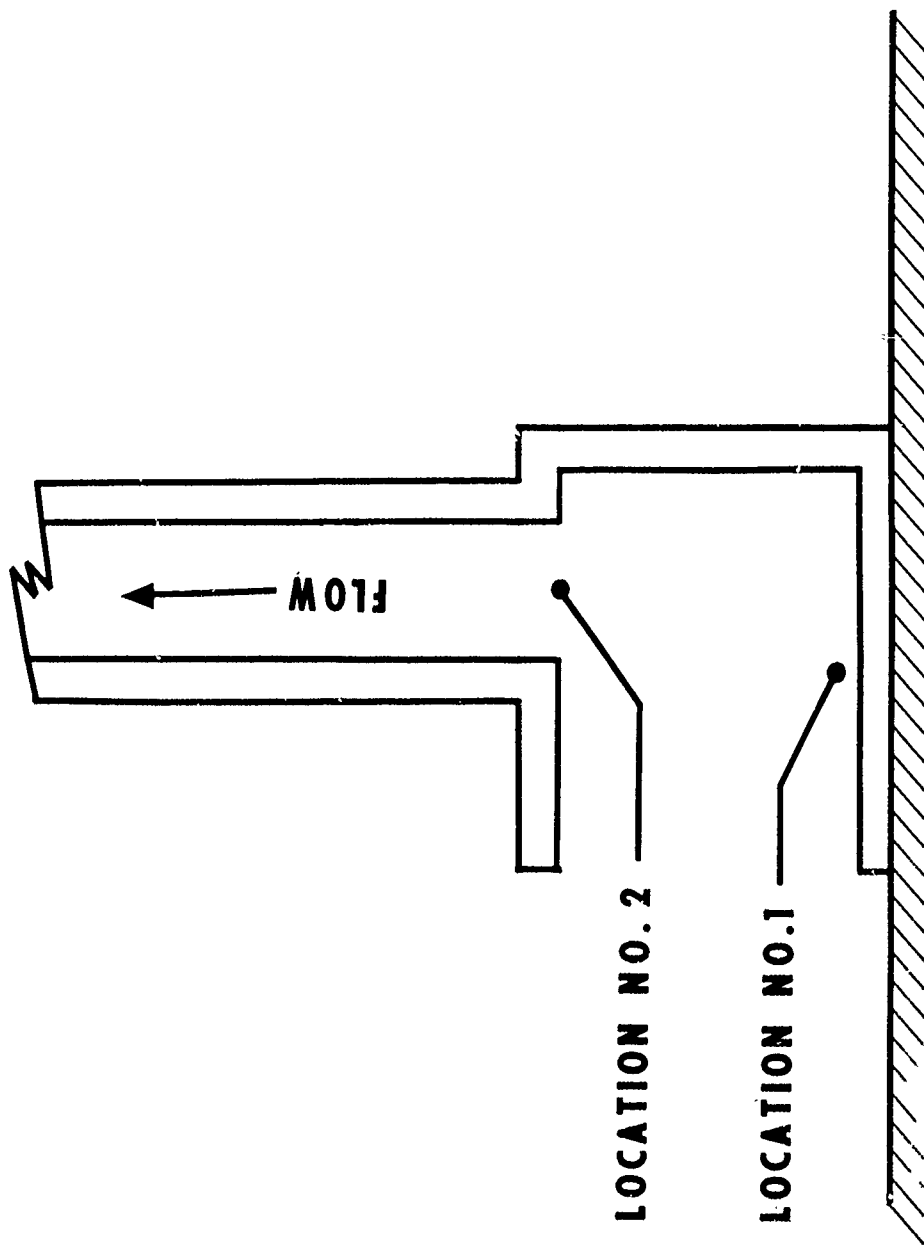

Figure 4. Location of specific contaminant dispersant points.

the fuel filter. While continuing to dispense particles at Location No. 2, the flow rate was gradually reduced until at a flow rate of approximately 1.0 gpm the particles failed to continue up the pipe to the filter.

The same tests were then repeated in a similar manner using the 420- to 1000-micron particles. Again, none of these particles would travel up the inlet pipe when placed in Location No. 1, but when placed at Location No. 2 they readily moved into the system and were trapped by the filter. The flow rate was then varied over the entire range of 0.25 to 3.84 gpm to determine the behavior of the particles. At the 0.25 gpm idle flow condition, some of the particles would move up the fuel pipe. However, most of the contaminant remained within a few inches of the mouth of the pipe, circulating locally. As the flow rate was slowly increased from 0.25 gpm, the particles almost immediately moved up the pipe and into the filter.

No further testing was conducted with particles smaller than 420 microns. It was obvious that the smaller sizes would be induced into the fuel inlet tube and move more readily than the larger ones once they got into the area adjacent to the inlet pipe.

CONCLUSIONS

The fuel sampling program conclusively showed that fuel contamination to the extent specified in current turbine engine design and qualification specifications does occur in normal field service operation of US Army helicopters.

The suction fuel testing indicated that contaminants up to the largest particle size specified (1000-1500 microns) could be drawn into the engine fuel system. It is therefore concluded that both the quantity and character of the contaminants currently specified in MIL-E-8593A and MIL-E-5007D are reasonable.

The point which has not been addressed here is the matter of the total exposure of the engine components to the contaminated fuel, i.e., the test hours called out by the qualification requirements. This is the most difficult aspect of the whole contaminated fuel issue to quantify. But if the results of the work reported herein are considered in terms of the potential total life exposure of engine components, it is not difficult to imagine that some systems could reach contaminant exposure times of the order of that currently specified.

The current design approach to suction fuel systems for helicopters seems adequate--that is, the minimizing of pressure drop in the aircraft fuel system and the use of relatively fine (less than 30 microns absolute) filtration to protect most of the engine fuel components with a single stage of pumping designed to handle the full amount of contaminant.

TABLE 1. FUEL CONTAMINANT PACKAGE FOR MIL-E-8593A
ENGINE COMPONENT QUALIFICATION TESTING

Contaminant	Particle size, μm	Quantity, g/1000 gal
Ferrous-Ferric Iron Oxide (Fe_3O_4 , Black color, Magnetite)	0-5	14.0
Ferric Iron Oxide (Fe_2O_3 , Hematite)	0-5	14.5
Ferric Iron Oxide (Fe_2O_3 , Hematite)	5-10	1.5 (30)*
Crushed Quartz	150- 300	1.0
Crushed Quartz	300- 420	1.0
Crushed Quartz	420-1000	1.75
Crushed Quartz	1000-1500	0.25 (4)*
Prepared dirt conforming to A.C. Spark Plug Co. Part No. 1543637 (Coarse Arizona road dust)	Mixture as follows: 0-5 (12%) 5-10 (12%) 10-20 (14%) 20-40 (23%) 40-80 (30%) 80-200 (9%)	(8.0)*
Cotton linters	Prime cotton linters, First Cut Staple No. 7 (U.S. Department of Agriculture Grading Standards) as ground in a Wiley Mill and screened through a 4 mm screen	0.1
Crude naphthenic acid		0.03% by vol
Salt water prepared by dissolving salt in distilled water or other water containing not more than 200 parts per million of total solids.	4 parts by weight of NaCl 96 parts by weight of H_2O	0.01% by vol entrained
*Sub-total		

TABLE 2. JP-4 PARTICULATE CONTAMINANT CONCENTRATIONS
AT FORT HOOD, TEXAS (HOOD ARMY AIR FIELD)

Sample no.	Date	Aircraft reg no.	Aircraft type	Unit	Particulate concentration, g/1000 gal ^a						Sump	
					Fe ^b	Si ^b	Al ^b	Ca ^b	Total Non-Ferrous Oxides ^c	Total Particulate Contaminants		
4442	5-7-76	71-20474	OH-58A	2nd Armored Div	Nil ^d	Nil	Nil	Nil	Nil	Nil	Nil	-
6443	5-7-76	73-21850	UH-1H	2nd Armored Div	0.021	0.034	0.028	Nil	0.062	0.083	0.083	LF
6444	5-7-76	73-21850	UH-1H	2nd Armored Div	Nil	0.033	0.057	Nil	0.090	0.090	0.090	RF
6445	5-7-76	73-21850	UH-1H	2nd Armored Div	0.025	Nil	Nil	Nil	Nil	0.025	0.025	LF
6446	5-7-76	67-15654	AH-1G	2nd Armored Div	0.103	1.020	0.363	0.522	1.905	2.008	2.008	F
6447	5-7-76	68-16991	OV-1	2nd Armored Div	0.091	0.340	Nil	Nil	0.034	0.125	0.125	-
6448	5-7-76	68-13820	UH-1H	2nd Armored Div	0.031	Nil	Nil	Nil	Nil	0.031	0.031	LF
6449	5-7-76	70-16093	AH-1G	2nd Armored Div	Nil	Nil	Nil	Nil	Nil	Nil	Nil	A
6450	5-7-76	67-18491	CH-47B	Ft. Sill, OK	0.031	Nil	Nil	Nil	Nil	0.031	0.031	-
6451	5-7-76	70-16478	UH-1H	Ft. Sam Houston, TX	Nil	Nil	Nil	Nil	Nil	Nil	Nil	LF
6452	5-7-76	70-16478	UH-1H	Ft. Sam Houston, TX	0.014	0.069	Nil	Nil	0.069	0.083	0.083	RF
AV-E-8593B concentration					(30.0)	(4.0)			(8.0)	(42.0)		

Notes: Numbers in parentheses are designated concentrations (g/1000 gal) for specific constituents of AV-E-8593B test fluid.

^bCalculated as Fe₂O₃, SiO₂, Al₂O₃, and CaO, respectively.

^aAll particulate matter less than 10µm.

^cTotal Non-Ferrous Oxides = SiO₂ + Al₂O₃ + CaO (principal constituents of A.C. 1543637 prepared dirt)

^dNil—Below lower limit of resolution by X-Ray Fluorescence (<0.001 g/1000 gal.).

TABLE 3: JP-4 PARTICULATE CONTAMINANT CONCENTRATIONS
AT FORT BRAGG, NORTH CAROLINA (OAK GROVE
ARMY AIR FIELD)

Sample no.	Date	Aircraft reg no.	Aircraft type	Unit	Particulate concentration, g/1000 gal ^a						Sump
					Fe ^b	Si ^b	Al ^b	Ca ^b	Total Non-Ferrous Oxides ^c	Total Particulate Contaminants	
6413	5-17-76	70-16300	UH-1H	"B" Co, 82 Avn Bn	0.044	0.154	0.061	Nil ^d	0.215	0.259	LF
6414	5-17-76	70-16300	UH-1H	"B" Co, 82 Avn Bn	0.014	Nil	Nil	Nil	Nil	0.014	RF
6415	5-17-76	71-20251	UH-1H	"B" Co, 82 Avn Bn	0.040	0.039	0.207	Nil	0.246	0.286	LF
6416	5-17-76	71-20251	UH-1H	"B" Co, 82 Avn Bn	0.028	0.073	0.106	Nil	0.179	0.207	RF
6417	5-17-76	66-17144	UH-1H	28 Engr Bde	0.072	1.062	0.361	Nil	1.423	1.495	RF
6418	5-17-76	66-17144	UH-1H	28 Engr Bde	0.002	0.234	0.055	Nil	0.289	0.291	LF
6419	5-17-76	70-15152	OII-58A	3rd Bde	0.097	0.797	0.098	Nil	0.895	0.992	LF
6420	5-17-76	68-16817	OII-58A	3rd Bde	0.055	1.919	0.122	Nil	2.041	2.096	LF
6421	5-17-76	68-15150	OII-58A	3rd Bde	0.071	0.442	0.130	Nil	0.572	0.643	LF
6422	5-17-76	72-21509	UH-1H	57th Med Ditch	0.042	0.290	0.054	Nil	0.344	0.386	RF
6423	5-17-76	72-21508	UH-1H	57th Med Ditch	0.026	0.079	0.073	Nil	0.152	0.178	LF
6424	5-17-76	73-21859	UH-1H	57th Med Ditch	0.027	1.354	0.081	Nil	1.435	1.462	RF
6425	5-17-76	73-21859	UH-1H	57th Med Ditch	0.082	0.248	0.099	Nil	0.347	0.429	LF
6426	5-17-76	70-20221	UH-1H	"A" Co, 82nd Avn Bn	0.063	0.458	0.122	Nil	0.580	0.643	RF
6427	5-17-76	70-21220	UH-1H	"A" Co, 82nd Avn Bn	0.071	0.499	0.176	Nil	0.675	0.746	LF
6428	5-17-76	70-38748	UH-1H	146th Med Ditch	0.050	0.581	0.122	Nil	0.703	0.753	RF
6429	5-17-76	70-38748	UH-1H	146th Med Ditch	0.032	0.139	0.051	Nil	0.190	0.222	LF
6430	5-17-76	71-20263	UH-1H	146th Med Ditch	0.031	0.062	Nil	Nil	0.062	0.093	RF
6431	5-17-76	71-20263	UH-1H	146th Med Ditch	0.029	0.048	0.013	Nil	0.061	0.090	LF
6432	5-17-76	64-13586	UH-1H	146th Med Ditch	0.054	0.176	0.191	Nil	0.367	0.421	RF
6433	5-17-76	64-13586	UH-1H	146th Med Ditch	0.032	0.171	Nil	Nil	0.171	0.203	LF
6434	5-17-76	71-21761	UH-1H	146th Med Ditch	0.014	0.099	Nil	Nil	0.099	0.113	RF
6435	5-17-76	71-21761	UH-1H	146th Med Ditch	Nil	0.040	0.115	Nil	0.155	0.155	LF
6436	5-17-76			146th Med Ditch	Nil	Nil	Nil	Nil	Nil	Nil	-
6437	5-18-76	-	-	"D" Ditch 407th S&S	Nil	Nil	0.046	Nil	0.046	0.046	-
6438	5-18-76	-	-	"D" Ditch 407th S&S	0.064	1.388	0.223	Nil	1.611	1.675	-
6439	5-18-76	71-20230	UH-1H	517th Trans COSCOM	Nil	Nil	0.065	Nil	0.065	0.065	RF
6440	5-18-76	71-20230	UH-1H	517th Trans COSCOM	0.087	0.537	0.242	Nil	0.799	0.885	LF
6441	5-18-76	70-15084	OII-58A	18th Airborne Corps, Atty	0.020	0.644	0.164	Nil	0.808	0.828	-
AV-E-8593B concentration					(30.0)	(4.0)			(8.0)	(42.0)	
<p>Notes: Numbers in parentheses are designated concentrations (g/1000 gal) for specific constituents of AV-E-8593B fluid. ^b Calculated as Fe₂O₃, SiO₂, Al₂O₃, and CaO, respectively. ^a All particulate matter less than 10 μm. ^c Total Non-Ferrous Oxides = SiO₂ + Al₂O₃ + CaO. ^d Nil - Below lower limit of resolution by X-Ray Fluorescence (<0.001 g/1000 gal).</p>											

TABLE 4. JP-4 PARTICULATE CONTAMINANT CONCENTRATIONS
AT FORT BLISS, TEXAS (BIGGS ARMY AIR FIELD)

Sample no.	Date	Aircraft reg no.	Aircraft type	Unit	Particulate concentration, g/1000 gal. ^a				Total Non-Ferrous Oxides ^c	Total Particulate Contaminants	Sump
					Fe ^b	Si ^b	Al ^b	Ca ^b			
6483	6-15-76	-	-	3rd Air Cav	0.123	0.095	Nil ^d	Nil	0.095	0.218	
6478	6-15-76	-	-	3rd Air Cav	0.045	Nil	Nil	Nil	Nil	0.045	
6467	6-15-76	-	-	3rd Air Cav	0.095	0.193	0.063	Nil	0.256	0.351	
6462	6-15-76	-	-	3rd Air Cav	0.075	0.095	Nil	Nil	0.095	0.120	
6472	6-15-76	-	-	3rd Air Cav	0.118	0.264	Nil	0.070	0.334	0.452	
6477	6-15-76	-	-	3rd Cav HHT	Nil	Nil	Nil	Nil	Nil	Nil	
6461	6-15-76	68-16346	UH-1H	3rd Air Cav	0.059	0.194	0.109	Nil	0.303	0.362	RF
6482	6-15-76	68-16346	UH-1H	3rd Cav HHT	0.122	0.130	Nil	Nil	0.130	0.252	LF
6437	6-15-76	71-20984	AH-1G	3rd Air Cav	High particulate concentration. See Table 6.					14.97	A
6492	6-15-76	71-20984	AH-1G	3rd Air Cav	High particulate concentration. See Table 6.					3.79	F
6495	6-15-76	66-777	UH-1H	3rd Cav HHT	Nil	0.078	Nil	Nil	0.078	0.078	LF
6497	6-15-76	66-777	UH-1H	3rd Cav HHT	0.031	0.080	Nil	Nil	0.080	0.111	RF
6499	6-15-76	70-13953	AH-1G	3rd Air Cav	High particulate concentration. See Table 6.					2.01	F
6473	6-15-76	71-20587	OH-58A	3rd Air Cav	0.131	0.241	0.082	Nil	0.323	0.454	
6496	6-15-76	71-20667	OH-58A	3rd Air Cav	High particulate concentration. See Table 6.					1.600	
6498	6-15-76	71-20851	OH-58A	3rd Air Cav	0.021	0.162	Nil	Nil	0.162	0.183	
6494	6-15-76	72-21412	OH-58A	3rd Air Cav	Nil	0.277	Nil	Nil	0.277	0.277	
6490	6-15-76	-	-	283rd Med Ditch	0.037	0.093	Nil	Nil	0.093	0.130	
6489	6-15-76	-	-	283rd Med Ditch	Nil	0.067	Nil	Nil	0.067	0.067	
6479	6-15-76	66-16634	UH-1H	283rd Avn Co	0.011	0.101	Nil	Nil	0.101	0.112	RF
6484	6-15-76	66-16634	UH-1H	283rd Avn Co	0.022	0.104	Nil	Nil	0.104	0.126	LF
6468	6-15-76	68-15284	UH-1H	283rd Avn Co	0.033	0.155	0.036	Nil	0.191	0.224	RF
6463	6-15-76	68-15284	UH-1H	283rd Avn Co	0.027	0.297	0.110	Nil	0.407	0.434	LF
6464	6-15-76	66-1193	UH-1H	717th Hel Amb Co	0.021	0.394	0.059	Nil	0.453	0.474	RF
6485	6-15-76	66-1193	UH-1H	717th Hel Amb Co	Nil	Nil	Nil	Nil	Nil	Nil	LF
6470	6-15-76	66-16819	UH-1H	717th Hel Amb Co	0.023	0.412	0.069	Nil	0.481	0.504	RF
6465	6-15-76	66-16819	UH-1H	717th Hel Amb Co	0.014	0.115	Nil	Nil	0.115	0.129	LF
6474	6-15-76	70-16386	UH-1H	717th Hel Amb Co	Nil	0.196	Nil	Nil	0.196	0.196	RF
6469	6-15-76	70-16386	UH-1H	717th Hel Amb Co	0.015	0.120	Nil	Nil	0.120	0.135	LF
6480	6-15-76	74-22431	UH-1H	717th Hel Amb Co	Nil	0.248	Nil	Nil	0.248	0.248	RF
6475	6-15-76	74-22431	UH-1H	717th Hel Amb Co	Nil	0.162	Nil	Nil	0.162	0.162	LF
6491	6-15-76	74-22472	UH-1H	717th Hel Amb Co	Nil	0.050	Nil	Nil	0.050	0.050	RF
6488	6-15-76	74-22472	UH-1H	717th Hel Amb Co	0.033	0.241	Nil	Nil	0.241	0.274	LF
6466	6-15-76	-	-	DIO-POL	High particulate concentration. See Table 5.					754.000	
6471	6-15-76	-	-	DIO-POL	High particulate concentration. See Table 5.					4.000	
6486	6-15-76	-	-	DIO-POL	High particulate concentration. See Table 5.					862.000	
6476	6-15-76	-	-	DIO-POL	High particulate concentration. See Table 5.					6525.000	
6481	6-15-76	-	-	DIO-POL	High particulate concentration. See Table 5.					11.000	
6493	6-15-76	-	-	DIO-POL	0.062	0.112	Nil	Nil	0.112	0.174	
AV-E-8593B concentration					(30.0)	(4.0)			(8.0)	(42.0)	
<p>Notes: Numbers in parentheses are designated concentrations (g/1000 gal) for specific constituents of AV-E-8593B test fluid. ^b Calculated as Fe, Si, Al, and Ca, respectively. ^c All particulate matter less than 10 µm, except for 6466, 6476, 6486. ^d Total Non-Ferrous Oxides = SiO₂ + Al₂O₃ + CaO. ^e Nil: Below lower limit of resolution by X-Ray fluorescence (<0.001 g/1000 gal).</p>											

TABLE 5. PARTICULATE SIZE, MASS, AND CLASS DISTRIBUTION FOR BIGGS ARMY AIR FIELD UNDERGROUND STORAGE TANK SAMPLES

Sample no.	Location	Compound class	Estimated particulate concentration, g/1000 gal								Total
			>1000 μm	500-1000 μm	300-500 μm	102-300 μm	52-102 μm	26-52 μm	8-26 μm	0.45-8 μm	
6466	Biggs AAF DIO-POL Tank 3 Bottoms	Iron oxides ^a	203	100	58	96	97	85	70	Nil	709
		Quartz ^b	Nil	Nil	Nil	8	8	16	13	Nil	45
6476	Biggs AAF DIO-POL Tank 5 Bottoms	Iron oxides ^a	991	270	270	1890	1060	1040	196	Nil	5717
		Quartz ^b	Nil	Nil	23	354	199	195	37	Nil	808
6486	Biggs AAF DIO-POL Nozzle Downstream of Tank 3/4 Filter	Iron oxides ^a	Nil	Nil	Nil	135	9	Nil	Nil	Nil	144
		Quartz ^b	29	142	287	203	13	Nil	Nil	Nil	674
		Calcium silicates ^c	2	9	19	13	1	Nil	Nil	Nil	44
6471	Biggs AAF DIO-POL Center of Tank 4	Iron oxides ^a	d	d	d	d	d	d	1	d	1
		Quartz ^b	d	d	d	d	d	d	2	d	2
		Calcium silicates ^c	d	d	d	d	d	d	1	d	1
6481	Biggs AAF DIO-POL Center of Tank 6	Iron oxides ^a	d	d	d	d	d	d	8	d	8
		Quartz ^b	d	d	d	d	d	d	2	d	2
		Calcium silicates ^c	d	d	d	d	d	d	1	d	1

^a As Fe₂O₃.
^b As SiO₂ (α -quartz).
^c As CaAl₂Si₂O₈.
^d All particulate matter collected on 8- μm filter and consumed during XRD analysis.

TABLE 6. PARTICULATE SIZE, MASS, AND CLASS DISTRIBUTION FOR BIGGS ARMY AIR FIELD - REFUELED AIRCRAFT SAMPLES

Sample no.	Aircraft (unit)	Compound class	Estimated particulate concentration, g/1000 gal								Total
			>1000 μm	500-1000 μm	300-500 μm	102-300 μm	52-102 μm	26-52 μm	8-26 μm	0.45-8 μm	
6496	OH-58A, 71-20667 (3rd Air Cav)	Iron oxides ^d	Nil	Nil	0.18	0.07	Nil	Nil	Nil	Nil	0.25
		Quartz ^e	Nil	Nil	0.05	1.15	0.15	Nil	Nil	Nil	1.35
6499	AH-1G, 70-15953 ^a (3rd Air Cav)	Iron oxides ^d	Nil	0.02	0.20	0.02	Nil	Nil	Nil	Nil	0.24
		Quartz ^e	Nil	0.27	1.10	0.40	Nil	Nil	Nil	Nil	1.77
6487	AH-1G, 71-20984 ^b (3rd Air Cav)	Iron oxides ^d	g	g	g	g	g	g	1.00	g	1.00
		Quartz ^e	g	g	g	g	g	g	10.03	g	10.03
		Calcium silicates ^f	g	g	g	g	g	g	3.94	g	3.94
6492	AH-1G, 71-20984 ^b (3rd Air Cav)	Iron oxides ^d	g	g	g	g	g	g	0.57	g	0.57
		Quartz ^e	g	g	g	g	g	g	2.27	g	2.27
		Calcium silicates ^f	g	g	g	g	g	g	0.95	g	0.95

^aFront Drain.
^bAft Drain.
^cFront Drain.
^dAs Fe₂O₃.
^eAs SiO₂ (α -Quartz).
^fAs CaAl₂Si₂O₈.
^gAll particulate matter collected on 8- μm filter and consumed during XRD analysis.

TABLE 7. JP-4 PARTICULATE CONTAMINANT CONCENTRATIONS FOR BRAVE SHIELD XIV

Sample no.	Date	Aircraft reg no.	Aircraft type	Unit	Particulate Concentration, g/1000 gal. ^a							Sump
					Fe ^b	Si ^b	Al ^b	Ca ^b	Total Non-Ferrous Oxides ^c	Total Particulate Contaminants		
6545	8-23-76	74-22429	UH-1H	USAAASE, REDCOM	0.164	Nil	Nil	0.542	0.542	0.706	LF	
6546	8-23-76	74-22495	UH-1H	USAAASE, REDCOM	0.243	0.648	0.518	1.378	1.621	1.621	LF	
6558	8-23-76	--	--	5th Air Cav	0.144	Nil	Nil	Nil	Nil	0.144	--	
6561	8-23-76	--	--	5th Air Cav	0.519	0.798	Nil	0.798	1.317	1.317	--	
6566	8-23-76	--	--	5th Air Cav	0.048	1.299	Nil	1.299	1.347	1.347	--	
6551	8-23-76	68-15451	UH-1H	"B" Troop, 5th Air Cav	0.148	Nil	Nil	Nil	Nil	0.148	LF	
6547	8-23-76	71-20806	OH-58A	"C" Troop, 5th Air Cav	0.199	Nil	Nil	0.014	0.213	0.213	--	
6549	8-23-76	71-20444	OH-58A	"C" Troop, 5th Air Cav	2.018	2.266	2.743	5.245	7.263	7.263	--	
6550	8-23-76	71-21087	OH-58A	"C" Troop, 5th Air Cav	1.175	1.431	0.663	2.300	3.475	3.475	--	
6548	8-23-76	68-15769	UH-1H	"C" Troop, 5th Air Cav	0.113	Nil	Nil	0.028	0.141	0.141	LF	
6553	8-23-76	69-15171	UH-1H	540 Avn Co, Wash Ang	0.215	Nil	Nil	0.056	0.271	0.271	LF	
6552	8-23-76	71-20215	UH-1H	116th Avn Co	0.089	Nil	Nil	Nil	0.089	0.089	LF	
6560	8-23-76	68-16239	UH-1H	116th Avn Co	0.104	Nil	Nil	Nil	0.104	0.104	LF	
6562	8-23-76	66-00856	UH-1H	116th Avn Co	0.141	Nil	Nil	Nil	0.141	0.141	LF	
6563	8-23-76	65-9967	UH-1H	116th Avn Co	0.178	Nil	Nil	0.050	0.228	0.228	LF	
6556	8-23-76	66-17864	UH-1H	116th Avn Co	0.124	Nil	Nil	Nil	0.124	0.124	LF	
6554	8-23-76	71-20763	OH-58A	9th Div	0.294	0.624	Nil	0.048	0.967	0.967	--	
6555	8-23-76	71-20586	OH-58A	9th Div	0.694	0.700	0.401	0.087	1.882	1.882	--	
6557	8-23-76	69-16723	UH-1H	9th Div	0.086	Nil	Nil	Nil	0.086	0.086	LF	
6559	8-23-76	70-15254	OH-58A	9th Div Aty	0.077	Nil	Nil	Nil	0.077	0.077	--	
6564	8-23-76	70-16384	UH-1H	9th Avn Bn	0.066	Nil	Nil	Nil	0.066	0.066	LF	
6568	8-23-76	66-16627	UH-1H	9th Avn Bn	0.077	Nil	Nil	Nil	0.077	0.077	LF	
6565	8-23-76	70-15311	OH-58A	"C" Troop, 9th Avn Co	0.165	Nil	Nil	0.035	0.200	0.200	--	
6569	8-23-76	66-16616	UH-1H	54th Med Avn Co	0.127	Nil	Nil	0.050	0.177	0.177	LF	
6570	8-23-76	70-16381	UH-1H	54th Med Avn Co	0.101	Nil	Nil	0.050	0.151	0.151	LF	
6567	8-23-76	73-21786	UH-1H	411th Trans Co	0.124	Nil	Nil	Nil	0.124	0.124	LF	

(30.0) (4.0) (8.0) (42.0)

Notes: Numbers in parentheses are designated concentration (g/1000 gal) for specific constituents of AV-E-8593B fluid.

^bCalculated as Fe₂O₃, SiO₂, Al₂O₃, + CaO.

^aAll particulate matter less than 10 μm.

^cTotal Non-Ferrous Oxides = SiO₂ + Al₂O₃ + CaO.

^dNil—Below lower limit of resolution by X-Ray Fluorescence (<0.001 g/1000 gal).

TABLE 8. JP-4 PARTICULATE CONTAMINANT CONCENTRATIONS FOR REFORGER

Sample no.	Aircraft reg. no.	Aircraft type	Unit	Particulate Concentration, g/1000 gal. ^a						Sump
				Fe ^b	Si ^b	Al ^b	Ca ^b	Total Non-Ferrous Oxides ^c	Total Particulate Contaminants	
6579	71-20142	UII-1H	"A" Co, 5th Trans Bn	0.112	0.854	Nil ^d	0.026	0.880	0.992	RF
6578	71-20142	UII-1H	"A" Co, 5th Trans Bn	0.215	0.953	Nil	0.039	0.992	1.208	LF
6613	74-22359	UII-1H	"A" Co, 5th Trans Bn	0.049	Nil	Nil	Nil	Nil	0.049	RF
6612	74-22359	UII-1H	"A" Co, 5th Trans Bn	0.178	0.894	Nil	0.122	1.016	1.194	LF
6591	69-15369	UII-1H	"A" Co, 5th Trans Bn	0.398	Nil	Nil	0.029	0.029	0.127	RF
6590	69-15369	UII-1H	"A" Co, 5th Trans Bn	0.129	1.095	Nil	Nil	1.095	2.070	LF
6593	69-15754	UII-1H	"A" Co, 5th Trans Bn	0.111	Nil	Nil	0.025	0.025	0.136	RF
6592	69-15754	UII-1H	"A" Co, 5th Trans Bn	0.074	Nil	Nil	0.042	0.042	0.116	LF
6586	73-21709	UII-1H	"A" Co, 5th Trans Bn	0.098	Nil	Nil	Nil	Nil	0.098	RF
6585	73-21709	UII-1H	"A" Co, 5th Trans Bn	0.123	Nil	Nil	0.029	0.029	0.152	LF
6584	70-15798	UII-1H	"A" Co, 5th Trans Bn	0.130	1.328	Nil	0.050	1.378	1.508	LF
6582	66-19135	CH-47B	"A" Co, 5th Trans Bn	0.429	1.558	0.466	0.151	2.175	2.604	R
6581	66-19135	CH-47B	"A" Co, 5th Trans Bn	0.186	0.791	0.376	0.118	1.284	1.470	L
6580	67-15721	AH-1G	"A" Co, 5th Trans Bn	0.297	2.945	0.549	0.151	3.644	3.941	F
6594	70-16045	AH-1G	"A" Co, 5th Trans Bn	High Particulate Concentration. See Table 9					21.550	F
6583	70-15238	OII-58A	"A" Co, 5th Trans Bn	0.075	Nil	Nil	Nil	Nil	0.075	
6589	68-16977	OII-58A	"A" Co, 5th Trans Bn	0.563	0.473	Nil	0.170	0.643	1.206	
6588	67-17672	UII-1H	"B" Co, 5th Trans Bn	0.228	7.152	Nil	0.113	7.265	7.493	RF
6587	67-17672	UII-1H	"B" Co, 5th Trans Bn	0.237	1.899	Nil	0.038	1.937	2.174	LF
6595	Pol-Rapid Refill Point		"D" Co, 426 S&S Bn	0.122	Nil	Nil	Nil	Nil	0.122	
6596	Pol-Rapid Refill Point		"D" Co, 426 S&S Bn	0.155	Nil	Nil	0.043	0.043	0.198	
6597	Pol-Rapid Refill Point		"D" Co, 426 S&S Bn	0.056	Nil	Nil	Nil	Nil	0.056	
6598	7G1216	Tank Truck	"D" Co, 426 S&S Bn	0.068	Nil	Nil	Nil	Nil	0.068	
6599	007-0-323-9P	Railway tank car	493 S&S Co, 87th Maint Bn	0.102	Nil	Nil	0.037	0.037	0.139	
6600	007-0-323-9P	Railway tank car	493 S&S Co, 87th Maint Bn	0.683	15.806	Nil	0.760	16.566	17.249	
6601	70-15561	OII-58A	175 Av Co, 1st Arm Div	0.360	0.940	0.463	0.107	1.511	1.871	
6602	72-21405	OII-58A	175 Av Co, 1st Arm Div	0.245	Nil	0.346	0.131	0.477	0.722	
6603	71-20497	OII-58A	25 Av Co, VII Corps	High Particulate Concentration. See Table 9					138.900	
6604	70-15172	OII-58A	25 Av Co, VII Corps	0.136	0.658	0.518	0.071	1.247	1.383	
6606	70-15771	UII-1H	25 Av Co, VII Corps	0.087	Nil	Nil	Nil	Nil	0.087	RF
6605	70-15771	UII-1H	25 Av Co, VII Corps	0.072	Nil	Nil	Nil	Nil	0.072	LF
6611	NK02VN	Tank truck	25 Av Co, VII Corps	0.097	Nil	Nil	Nil	Nil	0.097	
6610	68-15755	UII-1H	IIIIC 2nd Support Com	0.114	Nil	Nil	0.070	0.070	0.184	RF
6609	68-15755	UII-1H	IIIIC 2nd Support Com	0.095	Nil	Nil	Nil	Nil	0.095	LF
6608	73-21770	UII-1H	IIIIC 2nd Support Com	0.096	Nil	Nil	0.022	0.022	0.118	RF
6607	73-21770	UII-1H	IIIIC 2nd Support Com	0.141	Nil	Nil	0.124	0.124	0.265	LF
6618	74-22329	UII-1H	30th Trans Co	0.162	0.988	Nil	0.029	1.017	1.179	RF
6617	74-22329	UII-1H	30th Trans Co	0.133	0.836	0.385	0.038	1.259	1.392	LF
6620	65-12773	UII-1H	30th Trans Co	0.099	Nil	Nil	0.068	0.068	0.167	RF
6619	65-12773	UII-1H	30th Trans Co	0.085	Nil	Nil	Nil	Nil	0.085	LF
6622	69-17126	CH-47C	30th Trans Co	0.332	1.153	0.746	0.364	2.264	2.596	RF
6621	69-17126	CH-47C	30th Trans Co	1.464	5.433	0.849	0.568	6.850	8.314	LF
6623	70-15127	OII-58A	30th Trans Co	0.093	Nil	Nil	0.054	0.054	0.147	RF
6615	71-20838	OII-58A	"B" Troop 2/17 Cav	1.523	2.468	1.501	0.485	4.455	5.978	
6614	71-21031	AH-1G	"C" Troop 2/17 Cav	High Particulate Concentration. See Table 9					54.890	F
				(30.0)	(4.0)			(8.0)	(42.0)	

Notes: Numbers in parentheses are designated concentration (g/1000 gal) for specific constituents of AV-E-8593B fluid.
^bCalculated as Fe₂O₃, SiO₂, Al₂O₃ + CaO.
^aAll particulate matter less than 10 μm.
^cTotal Non-Ferrous Oxides = SiO₂ + Al₂O₃ + CaO.
^dNil—Below lower limit of resolution by X-Ray Fluorescence (<0.001 g/1000 gal).

TABLE 9. JP-4 PARTICULATE CONTAMINANT CONCENTRATIONS FOR REFORGER (ESTIMATED)

Sample No.	Aircraft (Unit)	Compound Class	Estimated particulate concentration, g/1000 gal.								Total
			>1000 μm	500-1000 μm	300-500 μm	102-300 μm	52-102 μm	26-52 μm	8-26 μm	0.45-8 μm	
6594	AH-1G, 70-16045 ^a ("A" Co. 5th Trans Bn)	Iron oxides ^b	0.91	0.11	0.23	0.54	0.30	1.24	2.08	Nil	5.41
		Quartz ^c	Nil	Nil	Nil	1.66	Nil	1.24	2.08	Nil	4.98
		Calcium silicates	Nil	Nil	Nil	Nil	Nil	1.65	2.78	Nil	4.43
		Zinc compounds ^d	6.73	Nil	Nil	Nil	Nil	Nil	Nil	Nil	6.73
6603	OH-58A, 71-20497 (25 AV Co., VII Corps)	Iron oxides ^b	16.85	25.99	12.12	10.54	0.66	0.38	Nil	Nil	66.54
		Quartz ^c	0.17	Nil	0.55	0.99	Nil	Nil	Nil	Nil	1.71
		Calcium silicates	Nil	Nil	Nil	Nil	Nil	Nil	Nil	Nil	Nil
		Zinc compounds ^d	19.49	25.76	12.06	10.48	0.79	0.49	1.58	Nil	70.65
6614	AH-1G, 71-21031 ^a ("C" Troop 2/17 Cav)	Iron oxides ^b	9.80	0.65	Nil	1.97	0.76	1.38	2.58	Nil	17.14
		Quartz ^c	5.10	Nil	Nil	1.58	1.78	4.81	18.05	Nil	31.32
		Calcium silicates	Nil	Nil	Nil	Nil	Nil	0.69	5.15	Nil	5.84
		Zinc compounds ^d	Nil	4.20	Nil	0.39	Nil	Nil	Nil	Nil	0.59

^aFront drain.

^bAs Fe₂O₃.

^cAs SiO₂ (α -quartz).

^dZnO and basic zinc carbonates, nonabrasive to steel.

TABLE 10. JP-4 PARTICULATE CONTAMINANT CONCENTRATIONS FOR BRAVE SHIELD XV

Sample no.	Date	Aircraft s-g. no.	Aircraft type	Unit	Particulate Concentration, g/1000 gal. ^a						Total Particulate Contaminants	Sump
					Fe ^b	Si ^b	Al ^b	Ca ^b	Total Non-Ferrous Oxides ^c	Total Particulate Contaminants		
6641	10-13-76	70-16293	UH-1H	119th Av Co	0.086	0.127	Nil ^d	Nil	0.127	0.213	LF	
6641	10-13-76	70-16293	UH-1H	119th Av Co	0.082	0.082	Nil	Nil	0.082	0.164	RF	
6644	10-13-76	70-16472	UH-1H	119th Av Co	0.087	0.231	Nil	Nil	0.231	0.318	LF	
6645	10-13-76	70-16472	UH-1H	119th Av Co	0.143	0.634	0.070	Nil	0.705	0.848	RF	
6646	10-13-76	69-15314	UH-1H	119th Av Co	0.090	0.131	0.054	Nil	0.185	0.204	LF	
6647	10-13-76	69-15314	UH-1H	119th Av Co	0.126	0.248	0.080	Nil	0.314	0.440	LF	
6648	10-13-76	69-15853	UH-1H	119th Av Co	0.069	0.233	Nil	Nil	0.233	0.302	RF	
6649	10-13-76	69-15853	UH-1H	119th Av Co	0.066	0.157	Nil	Nil	0.157	0.223	RF	
6650	10-13-76	64-13536	UH-1H	119th Av Co	0.074	0.092	Nil	Nil	0.092	0.146	Fwd	
6651	10-13-76	64-13536	UH-1H	119th Av Co	0.071	0.117	Nil	Nil	0.117	0.188	HoSe	
6652	10-13-76	No. 47	Tank truck	119th Av Co	0.067	0.143	Nil	Nil	0.143	0.210	LF	
6653	10-13-76	69-16000	UH-1H	119th Av Co	0.080	0.154	0.061	Nil	0.216	0.296	RF	
6654	10-13-76	69-16000	UH-1H	119th Av Co	Nil	0.071	Nil	Nil	0.071	0.071	LF	
6655	10-13-76	69-15315	UH-1H	119th Av Co	0.077	0.102	0.026	Nil	0.128	0.205	RF	
6656	10-13-76	65-9749	UH-1H	119th Av Co	0.060	0.127	Nil	Nil	0.127	0.177	LF	
6657	10-13-76	65-9749	UH-1H	119th Av Co	0.049	0.127	Nil	Nil	0.127	0.176	RF	
6658	10-13-76	65-9749	UH-1H	119th Av Co	0.105	0.165	0.093	Nil	0.258	0.363	LF	
6659	10-13-76	70-16470	UH-1H	119th Av Co	0.063	0.118	0.080	Nil	0.198	0.261	RF	
6660	10-13-76	70-16470	UH-1H	119th Av Co	0.071	0.188	Nil	Nil	0.188	0.259	LF	
6661	10-13-76	69-15318	UH-1H	119th Av Co	0.105	0.170	0.031	Nil	0.201	0.306	RF	
6662	10-13-76	69-15318	UH-1H	119th Av Co	High Particulate Concentration. See Table 11	High Particulate Concentration. See Table 11	High Particulate Concentration. See Table 11	High Particulate Concentration. See Table 11	High Particulate Concentration. See Table 11	High Particulate Concentration. See Table 11	High Particulate Concentration. See Table 11	
6664	10-13-76	70-15613	OH-58A	"B" Co, 82nd Av Bn	Nil	0.141	Nil	Nil	0.141	0.141	Fwd	
6665	10-13-76	72-21194	OH-58A	"B" Co, 82nd Av Bn	0.121	0.309	0.108	Nil	0.416	0.537	Aft	
6666	10-13-76	70-15150	OH-58A	"B" Co, 82nd Av Bn	0.078	0.113	Nil	Nil	0.113	0.191	Fwd	
6667	10-13-76	69-16096	OH-58A	"B" Co, 82nd Av Bn	0.370	0.472	0.121	Nil	0.593	0.963	Aft	
6668	10-13-76	67-18430	CH-54A	478 Av Bn	0.335	0.286	0.099	Nil	0.385	0.720	Fwd	
6669	10-13-76	67-18430	CH-54A	478 Av Bn	0.123	0.118	Nil	Nil	0.118	0.241	Aft	
6670	10-13-76	67-18420	CH-54A	478 Av Bn								
6671	10-13-76	67-18420	CH-54A	478 Av Bn								
6672	10-13-76	67-18424	CH-54A	478 Av Bn								
6673	10-13-76	67-18424	CH-54A	478 Av Bn								
					(30.0)	(4.0)	(8.0)	(42.0)				

Notes: Numbers in parentheses are designated concentration (g/1000 gal) for specific constituents of AV-E-8593B fluids.

^aCalculated as Fe₂O₃, Al₂O₃ + CaO.

^bAll particulate matter less than 10 μm.

^cTotal Non-Ferrous Oxides = SiO₂ + Al₂O₃ + CaO.

^dNil—Below lower limit of resolution by X-Ray fluorescence (<0.001 g/1000 gal).

TABLE 11. JP-4 PARTICULATE CONTAMINANT CONCENTRATIONS FOR BRAVE SHIELD (ESTIMATED)

Sample no.	Aircraft (unit)	Compound class	Estimated particulate concentration, g/1000 gal.										Total
			>1000 μm	500-100 μm	300-500 μm	102-300 μm	52-102 μm	26-52 μm	8-26 μm	0.45-8 μm			
6664	OH-58A,70-15613 ("B" Co 82nd Av Bn)	Iron oxides ^a	Nil	0.50	0.48	0.63	0.08	0.22	0.12	Nil	2.0		
		Quartz ^b	0.098	4.35	6.90	25.56	0.70	0.56	0.53	0.10	38.8		
		Calcium silicates	Nil	1.20	1.30	3.82	Nil	Nil	Nil	Nil	6.3		
		Zinc compounds ^c	Nil	Nil	Nil	Nil	Nil	Nil	Nil	Nil	Nil		
6665	OH-58A,72-21194 ("B" Co 82nd Av Bn)	Iron oxides ^a							0.95		0.95		
		Quartz ^b							3.82		3.82		
		Calcium silicates							Nil		Nil		
		Zinc compounds ^c							Nil		Nil		
6666	OH-58A,70-15150 ("B" Co 82nd Av Bn)	Iron oxides ^a	0.74	0.15	0.26	0.51	0.46	0.32	0.16	Nil	2.6		
		Quartz ^b	0.55	1.39	1.81	4.98	2.80	0.73	0.74	0.05	13.1		
		Calcium silicates	0.16	0.12	0.15	0.97	0.60	Nil	0.14	Nil	2.1		
		Zinc compounds ^c	Nil	Nil	Nil	Nil	Nil	Nil	Nil	Nil	Nil		
6667	OH-58A,69-16096 ("B" Co 82nd Av Bn)	Iron oxides ^a	Nil	0.21	0.20	1.62	0.91	0.32	0.25	Nil	3.5		
		Quartz ^b	Nil	0.52	1.40	13.44	3.96	1.04	1.24	0.07	21.7		
		Calcium silicates	Nil	0.45	Nil	3.44	1.11	0.16	0.98	Nil	6.1		
		Zinc compounds ^c	Nil	Nil	Nil	Nil	Nil	Nil	Nil	Nil	Nil		

^aAs Fe₂O₃.
^bAs SiO₂ (α -Quartz).
^cZnO and basic zinc carbonates, nonabrasive to steel.

TABLE 12. JP-4 PARTICULATE CONTAMINANT CONCENTRATIONS FOR GALLANT CREW

Sample No.	Date	Aircraft reg. no.	Aircraft type	Unit	Particulate Concentration, g/1000 gal. ^a						Sump
					Fe ^b	Si ^b	Al ^b	Ca ^b	Total Non-Ferrous Oxides ^c	Total Particulate Contaminants	
6878	3-28-77	--	Bladder No. 1	13th COSCOM	0.077	0.625	NH ^d	0.039	0.664	0.741	--
6879	3-28-77	--	Bladder No. 2	13th COSCOM	0.058	NH	NH	NH	NH	0.058	--
6880	3-28-77	--	Bladder No. 4	13th COSCOM	0.077	NH	NH	NH	NH	0.077	--
6881	3-28-77	--	Bladder No. 6	13th COSCOM	NH	NH	NH	NH	NH	NH	--
6882	3-28-77	--	Bladder No. 3	13th COSCOM	NH	NH	NH	NH	NH	NH	--
6883	3-28-77	70-16211	UH-1H	HHC Troop 4/9 Cav	0.103	0.460	NH	NH	0.460	0.563	RF
6884	3-28-77	70-16211	UH-1H	HHC Troop 4/9 Cav	0.077	0.313	NH	NH	0.313	0.390	LF
6885	3-28-77	71-20554	OH-58A	"A" Troop 7/17 Cav	0.198	1.061	0.388	0.221	1.670	1.868	--
6886	3-28-77	71-20224	UH-1H	HHC Troop 7/17 Cav	0.058	0.258	NH	NH	0.258	0.316	LF
6887	3-28-77	71-20224	UH-1H	HHC Troop 7/17 Cav	NH	0.263	NH	NH	0.263	0.263	RF
6888	3-28-77	69-15010	UH-1H	HHC Troop 7/17 Cav	NH	NH	NH	NH	NH	NH	LF
6889	3-28-77	69-15010	UH-1H	HHC Troop 7/17 Cav	0.065	NH	NH	NH	NH	0.065	RF
6890	3-28-77	71-20223	UH-1H	HHC Troop 7/17 Cav	0.122	0.608	0.188	0.117	1.913	2.035	LF
6891	3-28-77	71-20223	UH-1H	HHC Troop 7/17 Cav	0.152	0.791	0.223	0.242	1.256	1.256	RF
6892	3-28-77	70-15371	OH-58A	3rd Bde 1st Cav	0.105	0.839	0.149	0.109	1.096	1.201	--
6893	3-28-77	70-15010	CH-47C	"D" Co. 34th Spt 6ACCB	0.517	1.333	0.929	0.114	2.376	2.893	LF
6894	3-28-77	70-15010	CH-47C	"D" Co. 34th Spt 6ACCB	0.084	0.278	NH	NH	0.278	0.362	RF
6895	3-28-77	70-15008	CH-47C	"D" Co. 34th Spt 6ACCB	High Particulate Concentration (see Table 13)					11.780	LF
6896	3-28-77	70-15008	CH-47C	"D" Co. 34th Spt 6ACCB	0.558	1.665	NH	NH	1.665	2.223	RF
6897	3-28-77	70-15027	CH-47C	"D" Co. 34th Spt 6ACCB	1.007	5.490	2.242	0.073	7.805	8.812	LF
6898	3-28-77	70-15027	CH-47C	"D" Co. 34th Spt 6ACCB	1.465	8.754	3.738	0.887	13.378	14.843	RF
6899	3-28-77	70-15025	CH-47C	"D" Co. 34th Spt 6ACCB	0.107	NH	NH	NH	NH	0.107	LF
6900	3-28-77	70-15025	CH-47C	"D" Co. 34th Spt 6ACCB	0.104	0.262	NH	0.297	0.560	0.664	LM
6901	3-28-77	70-15025	CH-47C	"D" Co. 34th Spt 6ACCB	0.638	5.460	1.614	2.741	9.814	10.452	RR
6902	3-28-77	70-15025	CH-47C	"D" Co. 34th Spt 6ACCB	0.354	1.706	0.515	1.044	3.265	3.619	RM
6903	3-29-77	66-00888	UH-1H	528th Trans, 13th COSCOM	0.083	NH	NH	NH	NH	0.083	LF
6904	3-29-77	66-00888	UH-1H	528th Trans, 13th COSCOM	0.123	0.111	NH	NH	0.111	0.234	RF
6905	3-29-77	70-16265	UH-1H	162 Av Co (AH)	0.067	NH	NH	NH	NH	0.067	LF
6906	3-29-77	70-16265	UH-1H	162 Av Co (AH)	0.090	NH	NH	NH	NH	0.090	RF
6907	3-29-77	68-16614	UH-1H	162 Av Co (AH)	0.269	0.646	NH	0.546	1.192	1.461	LF
6908	3-29-77	68-16614	UH-1H	162 Av Co (AH)	0.127	0.246	NH	NH	0.246	0.373	RF
6909	3-29-77	68-16627	UH-1H	162 Av Co (AH)	0.082	NH	NH	NH	NH	0.082	LF
6910	3-29-77	68-16627	UH-1H	162 Av Co (AH)	0.087	NH	NH	NH	NH	0.087	RF
6911	3-29-77	--	Bladder	108th QM	0.063	NH	NH	NH	NH	0.063	--
6912	3-29-77	PSI-132	Tank Truck	108th QM	0.093	NH	NH	NH	NH	0.093	Nozzle
6913	3-29-77	PSI-132	Tank Truck	108th QM	0.067	NH	NH	NH	NH	0.067	Compartment
6914	3-29-77	70-15019	CH-47C	"D" Co 34th Spt 6ACCB	High Particulate Concentration (see Table 13)					158.920	RF
6915	3-29-77	70-15019	CH-47C	"D" Co 34th Spt 6ACCB	0.322	0.511	0.329	0.163	1.003	1.325	RR
6916	3-29-77	70-15019	CH-47C	"D" Co 34th Spt 6ACCB	1.663	10.828	3.726	7.376	21.930	23.593	LF
6917	3-29-77	70-15019	CH-47C	"D" Co 34th Spt 6ACCB	0.189	0.233	1.223	0.521	1.977	2.166	LR
					(30.0)	(4.0)			(8.0)	(42.0)	

Notes: Numbers in parentheses are designated concentration (g/1000 gal) for specific constituents of AV-E-8593B fluids.
^a Calculated as Fe, Si, Al, Ca + CaO.
^b All particulate matter less than 10 μm.
^c Total Non-Ferrous Oxides = SiO₂ + Al₂O₃ + CaO.
^d Nil - Below level limit of resolution by X-Ray Fluorescence (<0.001 g/1000 gal).

TABLE 13. JP-4 PARTICULATE CONTAMINANT CONCENTRATIONS FOR GALLANT CREW (ESTIMATED)

Sample no.	Aircraft (unit)	Compound class	Estimated particulate concentration, g/1000 gal.										Total
			>1000 µm	500-1000 µm	300-500 µm	102-300 µm	52-102 µm	26-52 µm	8-26 µm	0.45-8 µm			
6914	CH-47C, 70-15019 ^a ("D" Co. 34th Spt, 6AACB)	Iron oxides ^b	3.15	1.88	2.41	10.90	2.46	0.80	0.84	Nil	22.44		
		Quartz ^c	0.84	4.24	5.73	47.26	11.06	4.93	6.21	Nil	80.27		
		Calcium silicates ^d	0.25	4.23	3.88	31.72	7.99	3.37	4.77	Nil	56.21		
		Zinc compounds ^d	Nil	Nil	Nil	Nil	Nil	Nil	Nil	Nil	Nil		
6895	CH-47C, 70-15008 ^c ("D" Co. 34th Spt, 6AACB)	Iron oxides ^b	Nil	Nil	0.34	0.80	0.10	0.03	0.36	Nil	1.63		
		Quartz ^c	Nil	Nil	0.32	3.17	0.62	0.27	1.32	Nil	5.70		
		Calcium silicates ^d	Nil	Nil	0.10	1.80	0.07	Nil	2.48	Nil	4.45		
		Zinc compounds ^d	Nil	Nil	Nil	Nil	Nil	Nil	Nil	Nil	Nil		

^aLeft front drain.

^bAs Fe₂O₃.

^cAs SiO₂ (α-quartz).

^dZnO and basic zinc carbonates, nonabrasive to steel.

^eRight front drain.