

AD-A068 495

TRW INC REDONDO BEACH CALIF

F/G 21/5

SHARED APERTURE BREADBOARD TEST SYSTEM (SABTS) LASER SUPPORT.(U)

DEC 78 T V ROSZHART, W P BALL, J T SINGS

F29601-77-C-0010

UNCLASSIFIED

AFWL-TR-77-135

NL

1 OF 2  
AD  
A068-495

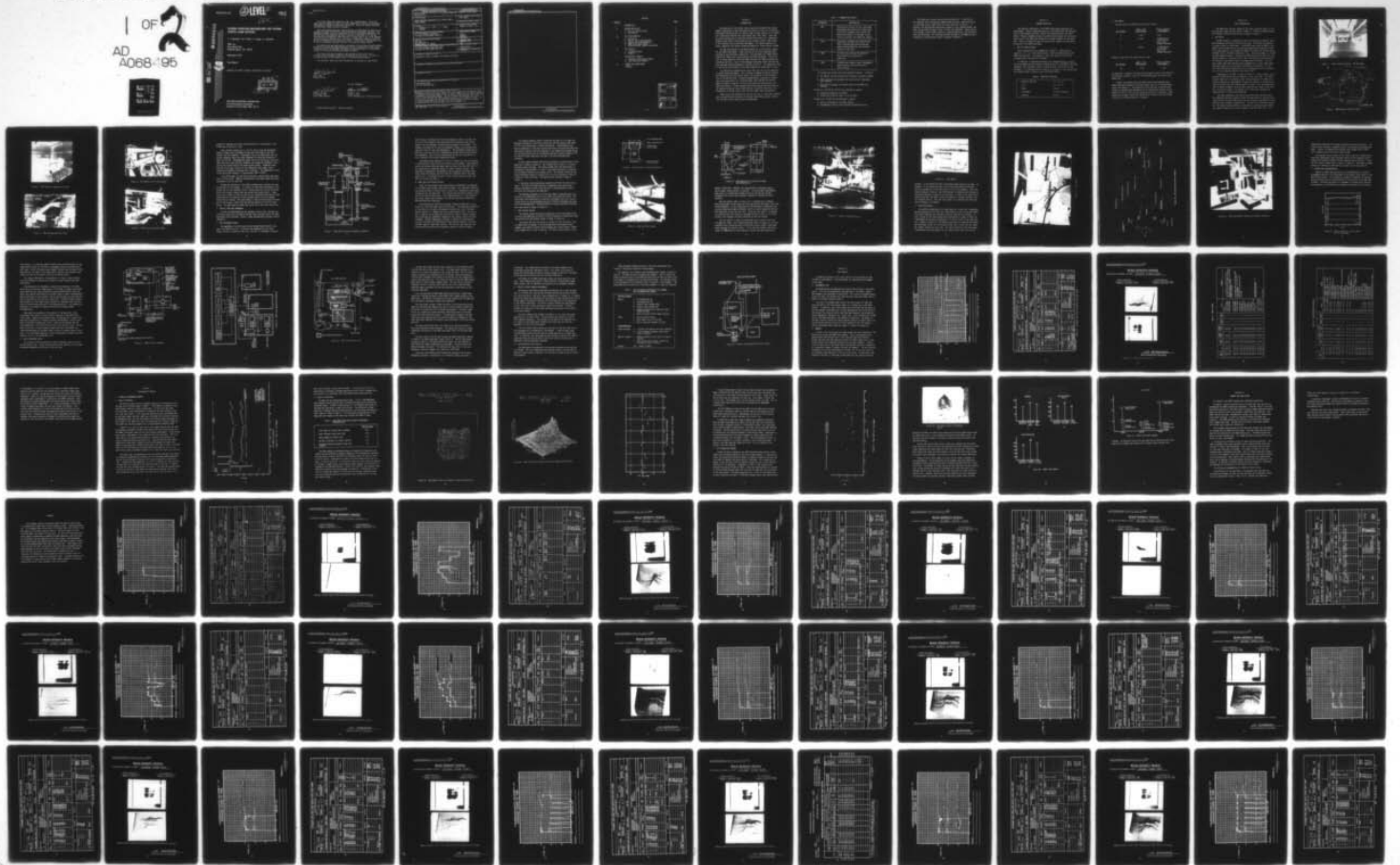

AFWL-TR-77-135

**(2) LEVEL III**

AFWL-TR-  
77-135

ADB 300265

DPC

AD A 068495

**SHARED APERTURE BREADBOARD TEST SYSTEM  
(SABTS) LASER SUPPORT**

T. V. Roszhart , W. P. Ball, J. T. Sings, J. L. Schmidt

TRW, Inc.  
One Space Park  
Redondo Beach, CA 90278

December 1978

Final Report

Approved for public release; distribution unlimited.

DDC FILE COPY

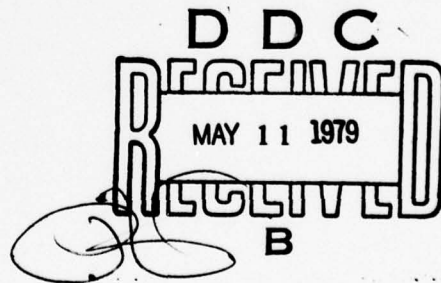

**AIR FORCE WEAPONS LABORATORY  
Air Force Systems Command  
Kirtland Air Force Base, NM 87117**

79 04 09 08

This final report was prepared by TRW, Inc., Redondo Beach, California, under Contract F29601-77-C-0010, Job Order 00020702 with the Air Force Weapons Laboratory, Kirtland Air Force Base, New Mexico. Capt Felix Morgan (ALO) was the Laboratory Project Officer-in-Charge.

When US Government drawings, specifications, or other data are used for any purpose other than a definitely related Government procurement operation, the Government thereby incurs no responsibility nor any obligation whatsoever, and the fact that the Government may have formulated, furnished, or in any way supplied the said drawings, specifications, or other data is not to be regarded by implication or otherwise as in any manner licensing the holder or any other person or corporation or conveying any rights or permission to manufacture, use, or sell any patented invention that may in any way be related thereto.

This report has been authored by a contractor of the United States Government. Accordingly, the United States Government retains a nonexclusive, royalty-free license to publish or reproduce the material contained herein, or allow others to do so, for the United States Government purposes.

This report has been reviewed by the Information Office (OI) and is releasable to the National Technical Information Service (NTIS). At NTIS, it will be available to the general public, including foreign nations.

This technical report has been reviewed and is approved for publication.



NORTON B. JAMES III  
Capt, USAF  
Project Officer

FOR THE COMMANDER



ARMAND D. MAIO  
Colonel, USAF  
Chief, Advanced Laser Technology Division



JAMES D. DILLOW  
Lt Colonel, USAF  
Chief, Optics Branch

UNCLASSIFIED

SECURITY CLASSIFICATION OF THIS PAGE (When Data Entered)

REPORT DOCUMENTATION PAGE		READ INSTRUCTIONS BEFORE COMPLETING FORM
1. REPORT NUMBER AFWL-TR-77-135	2. GOVT ACCESSION NO.	3. RECIPIENT'S CATALOG NUMBER
4. TITLE (and Subtitle) SHARED APERTURE BREADBOARD TEST SYSTEM (SABTS) LASER SUPPORT	5. TYPE OF REPORT & PERIOD COVERED Final Report	
	6. PERFORMING ORG. REPORT NUMBER	
7. AUTHOR(s) T. V. Roszhart, W. P. Ball, J. T. Sings, J. L. Schmidt	8. CONTRACT OR GRANT NUMBER(s) F29601-77-C-0010 <i>new</i>	
9. PERFORMING ORGANIZATION NAME AND ADDRESS Air Force Weapons Laboratory Kirtland Air Force Base, NM 87117	10. PROGRAM ELEMENT, PROJECT, TASK AREA & WORK UNIT NUMBERS 62601F 00020702	
11. CONTROLLING OFFICE NAME AND ADDRESS TRW, Inc. One Space Park Redondo Beach, CA 90278	12. REPORT DATE December 1978	
	13. NUMBER OF PAGES 182	
14. MONITORING AGENCY NAME & ADDRESS (if different from Controlling Office) Air Force Weapons Laboratory (ALO) Kirtland Air Force Base, NM 87117	15. SECURITY CLASS. (of this report) UNCLASSIFIED	
	15a. DECLASSIFICATION/DOWNGRADING SCHEDULE	
16. DISTRIBUTION STATEMENT (of this Report) Approved for public release; distribution unlimited.		
17. DISTRIBUTION STATEMENT (of the abstract entered in Block 20, if different from Report)		
18. SUPPLEMENTARY NOTES		
19. KEY WORDS (Continue on reverse side if necessary and identify by block number) High Energy Laser Dichroic Beam Splitter		
20. ABSTRACT (Continue on reverse side if necessary and identify by block number) Deuterium Fluoride (DF) High Energy Laser (HEL) support was provided for testing aperture sharing optical elements in the HEL beam using the Shared Aperture Breadboard Test System (SABTS). The TRW Baseline Demonstration Laser (BDL) HEL facility was modified for SABTS, and laser support was provided for survivability tests of coatings and performance tests of dichroic beam splitters. As an add-on experiment, HEL survivability and performance tests of microwave windows and missile guidance heads were also supported.		

DD FORM 1473

JAN 73

EDITION OF 1 NOV 65 IS OBSOLETE

UNCLASSIFIED

SECURITY CLASSIFICATION OF THIS PAGE (When Data Entered)

79 04 09 08

UNCLASSIFIED

SECURITY CLASSIFICATION OF THIS PAGE(When Data Entered)

[A large rectangular box with a black border, containing faint, illegible text and markings, possibly representing a redacted document or a form with very light print.]

UNCLASSIFIED

SECURITY CLASSIFICATION OF THIS PAGE(When Data Entered)

## CONTENTS

<u>Section</u>		<u>Page</u>
I	INTRODUCTION	1
II	PROGRAM OBJECTIVES	4
	1. Facility Specifications	4
	2. Test Matrix	5
III	TEST CONFIGURATION	6
	1. BDL Device	5
	2. Optical Train and Components	10
	3. Control and Instrumentation	21
	4. SABTS Experiment Layout	22
	5. Effects Station (Add-On Experiment)	27
IV	TEST RESULTS	30
	1. Performance Data	30
	2. Summary	30
V	DISCUSSION OF RESULTS	37
	1. Technical Performance Summary	37
	2. Test Operations Summary	43
VI	SUMMARY AND CONCLUSIONS	48
	APPENDIX	51

<b>ACCESSION for</b>		
NTIS	White Section	<input checked="" type="checkbox"/>
DDC	Buff Section	<input type="checkbox"/>
UNANNOUNCED		<input type="checkbox"/>
JUSTIFICATION _____		
BY _____		
<b>DISTRIBUTION/AVAILABILITY CODES</b>		
Dist.	AVAIL. and/or	SPECIAL
<b>A</b>		

## Section I

### INTRODUCTION

The objective of the overall Shared Aperture Breadboard Test System (SABTS) program was to test predicted survivability levels and to measure performance characteristics of dichroic beam splitter samples in an intense 3.8  $\mu\text{m}$  deuterium fluoride (DF) high energy laser (HEL) beam. These samples were developed for an aperture sharing device which will separate an outgoing laser beam of high intensity from incoming tracker light signal of low intensity and of different wavelength. The shared aperture will reduce complexity and improve system performance of future tracker systems.

The TRW contribution to the SABTS program was to provide HEL support for the SABTS experiments. Other portions of the total experiment were provided by two additional contractors. Ford Aerospace and Communication Corporation (FACC) built and maintained the SABTS equipment. The University of Dayton Research Institute (UDRI) operated the SABTS equipment and collected test data. The Air Force Weapons Laboratory (AFWL) provided the test specimens and coordinated all testing activities. The responsibilities of the various participants in the SABTS program are summarized in table 1.

The TRW baseline demonstration laser (BDL) HEL facility was modified to accept these experiments. This involved a somewhat extensive redesign and restructuring of the optical train, and renovation of the vestibule area of the BDL building. Extensive soundproofing, painting for cleanliness, and installation of a filtered blower were required to provide a positive pressure clean-air facility with tolerable vibrations for the SABTS test tables. Further changes involved the design and fabrication of the supporting optical train, modifications to existing facilities, and integration of the BDL device into the total SABTS test configuration.

Power levels were measured for each of the runs, so that when combined with the magnification settings of the beam conditioning system, intensities incident on the samples could be determined.

Table 1. PROGRAM PARTICIPANTS

CONTRACTOR	CONTRIBUTION
TRW	Provide test facility, DF HEL laser beam, measurement and monitoring of beam power, profile and alignment, data control and monitoring signals, TV coverage, consultation on testing, and technician support.
FACC	Fabricated, assembled and installed the SABTS including beam conditioning and sample testing apparatus and continued support to the tests.
UDRI	Provided test planning and execution, data collection, analysis and reporting.
AFWL	Provided test samples, overall management, administration, and coordination of entire program.

The program was divided into three sequential phases. In Phase I:

- The TRW BDL site was modified and prepared to accept the SABTS.
- SABTS apparatus and equipment was installed and integrated with facility.
- Startup and alignment of the BDL device to the SABTS was achieved.

In Phase II, the BDL HEL facility was operated to support:

- Acceptance testing of the SABTS.
- Coating survivability tests in the HEL beam.

In Phase III, the BDL HEL was operated to support:

- Optical evaluation of the SABTS samples.
- Supplementary Effects Tests outside the SABTS test area.

The objectives of each plan were met successfully. In particular, the completed test configuration demonstrated the power, beam characteristic and beam control capabilities that were specified for Phase I. In addition, the program test objectives (number of runs, samples tested, and total lasing time) of Phase II and III were also completed. These results are outlined in the various sections on program objectives, test configuration, and test data. All raw data has been included in an appendix with a discussion of the pertinent results included in Section V.

Section II  
PROGRAM OBJECTIVES

The technical objectives of the SABTS program were separated into three phases. Phase I objectives were test site preparation and configuration of the specimen test area, control and monitoring area, and laser device. Phase II objectives were to provide lasing support for the acceptance tests of the SABTS and screening of optimum coatings for the specimens. Phase III objectives were to provide laser support for the optical evaluation of the SABTS specimens.

1. FACILITY SPECIFICATION

Beam characteristics are summarized in table 2. Specifications require a  $\leq 3.7 \times 3.7$  cm DF beam having at least 36 kW delivered to the SABTS area entrance. The beam was to have less than 0.75 milliradian divergence and a duration of 20 seconds.

In addition, a laboratory area was to be provided having a suitable test environment and the capacity to house portions of the SABTS, including diagnostic test equipment, optical interface table, and mirror cooling equipment. This area was to be at least 8 by 6 meters in size and provided with adequate power, lighting, and cleanliness control.

Table 2. BEAM SPECIFICATIONS

Spectral Emission	3.5 - 4.1 $\mu$ m
Size	3.7 x 3.7 cm
Power	>36 kW
Divergence	<0.075 milliradian
Duration	$\approx$ 20 sec

## 2. TEST MATRIX

The test matrix for Phase II was to be as follows:

<u>No. of Runs</u>	<u>Approx. Run Time (Lasing)</u>	<u>Approx. Exposure Time/Sample</u>
2	5 sec	5 sec
8	12 sec	6 exposures of 0.25 sec each with 2 sec between exposures
4	30 sec	6 exposures of 3.0 sec each with 2 sec between exposures

Similarly, the matrix for Phase III was to be:

<u>No. of Runs</u>	<u>Approx. Run Time (Lasing)</u>	<u>Approx. Exposure Time/Sample</u>
40	5 sec	5 sec

An additional 7 seconds of lasing time was added to each of the above lasing durations (Phases II and III) for determining power delivered to the SABTS area.

A small-scale effects test was added later to the program scope. These tests were designed to run concurrently (and on a noninterference basis) with Phase III. The objective of the test was to provide laser support to determine the degradation of RF transmission through various materials with air flow over the target during laser irradiation. Other objectives included visual data from material fracture and burn-through rate data at different angles of incidence.

### Section III

#### TEST CONFIGURATION

The SABTS test area was located in the lower vestibule section of the building that houses the BDL device (figure 1). The BDL building location with respect to other CTS facilities is shown in figure 2.

#### 1. BDL DEVICE

The BDL system is a combustion driven, continuous wave chemical laser which produces a multiline infrared laser beam. The BDL may be operated in either a DF/HF or HF/DF mode. In the HF/DF case (used for SABTS), the atomic fluorine required for cold reaction operation was obtained by burning  $H_2$  and excess  $F_2$  in a combustion chamber to produce equilibrium concentrations of HF, F and small quantities of  $F_2$ . Helium was added as a diluent to these combustor gases to increase the effective specific heat ratio and thermal capacity of the gases and to lower the effective molecular weight. All three of these effects tend to increase laser efficiency. The combustor gases were then supersonically expanded into a cavity region where they were mixed with  $D_2$  to produce vibrationally excited DF, i.e., DF\*. The laser spectrum was centered near 3.8  $\mu m$  wavelength which is characteristic of the vibration-rotation transitions of DF\*.

A photograph of the BDL is shown in figure 3. Figure 4 shows a cross-sectional view with the various reactants in the flow field. The cavity injector consists of six modules, each 4-inches high and 10-inches long. Figure 5 shows the six BDL modules in place and figure 6 is a view of the front of the BDL with one injector nozzle in place. This configuration of the six modules produces an active gain cross section, normal to the flow axis, of 4 by 60 inches. The optical axis of the laser resonator was placed parallel to the 60-inch dimension.

The copper combustors and nozzles were cooled with deionized water. The combustor and nozzle coolant system are pump-fed due to the high flow rates (36 and 144 gpm, respectively) and low pressure requirements (45 and 150 psia inlet pressure, respectively). The low cavity pressure required for satisfactory laser operation is obtained by a two-stage steam condenser ejector system used as a pump system for the BDL laser flows. The

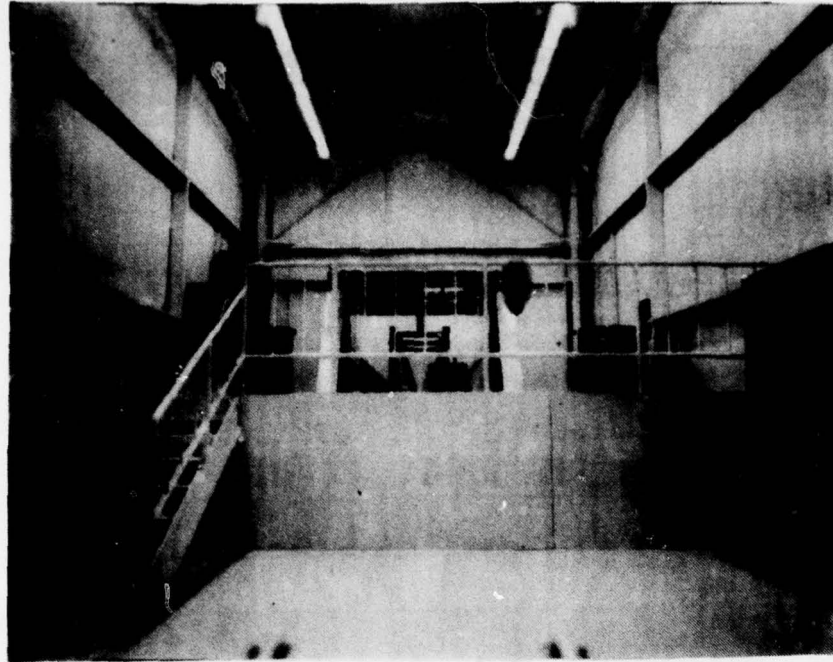

Figure 1. Lower Vestibule Section - BDL Building

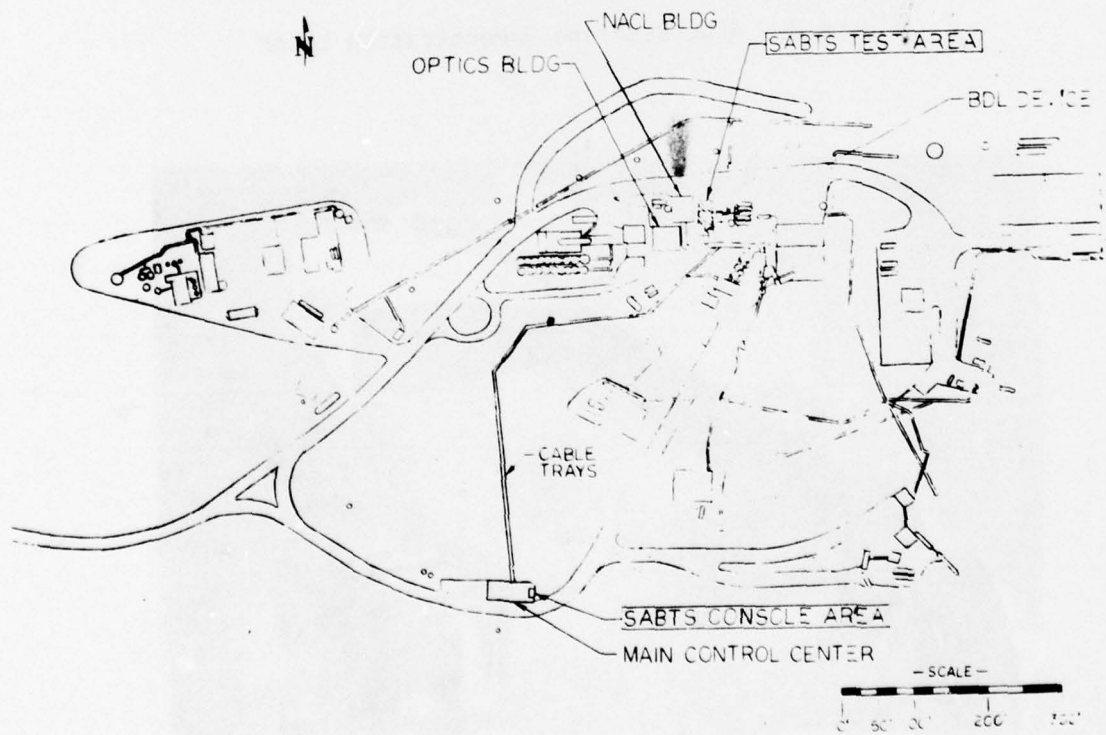

Figure 2. SABTS Overall Area (CTS Site)

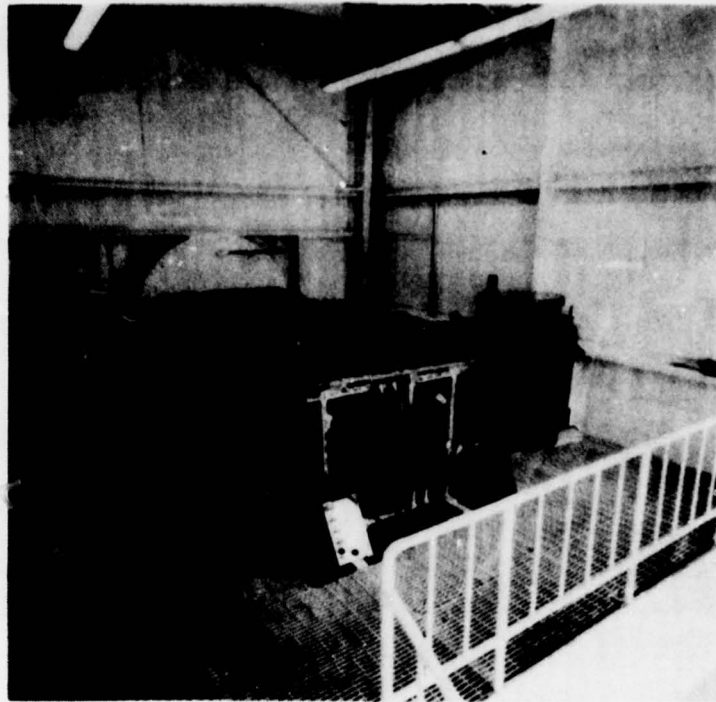

Figure 3. AFWL Baseline Demonstration Laser

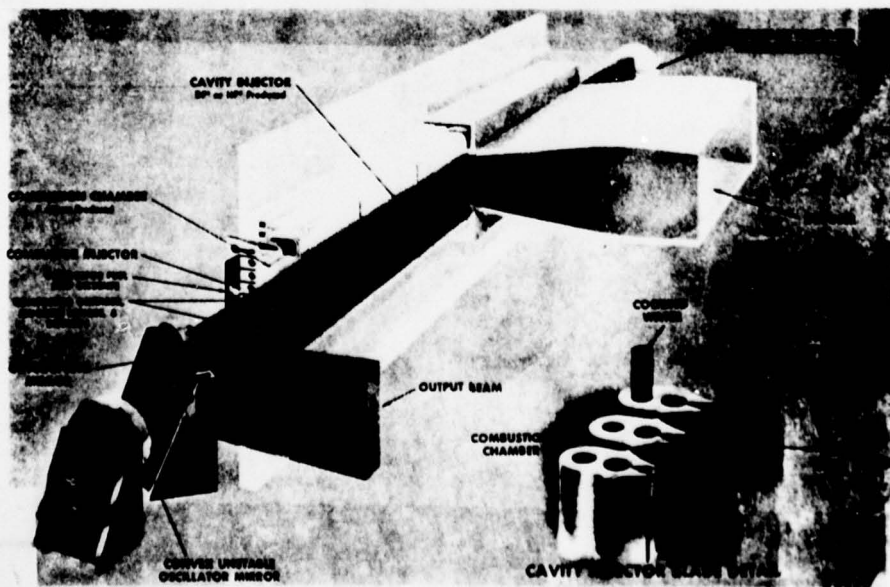

Figure 4. AFWL-BDL Reactant Flow Field

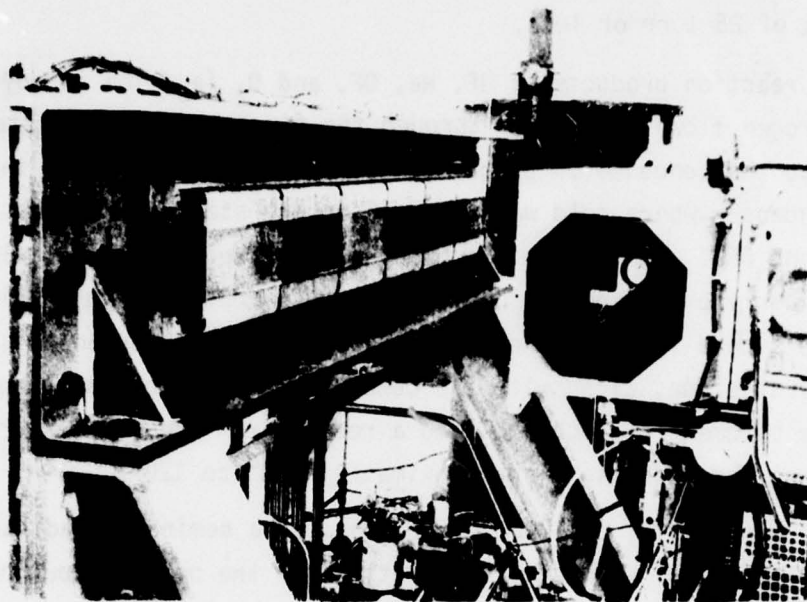

Figure 5. BDL Modules (Six) Installation

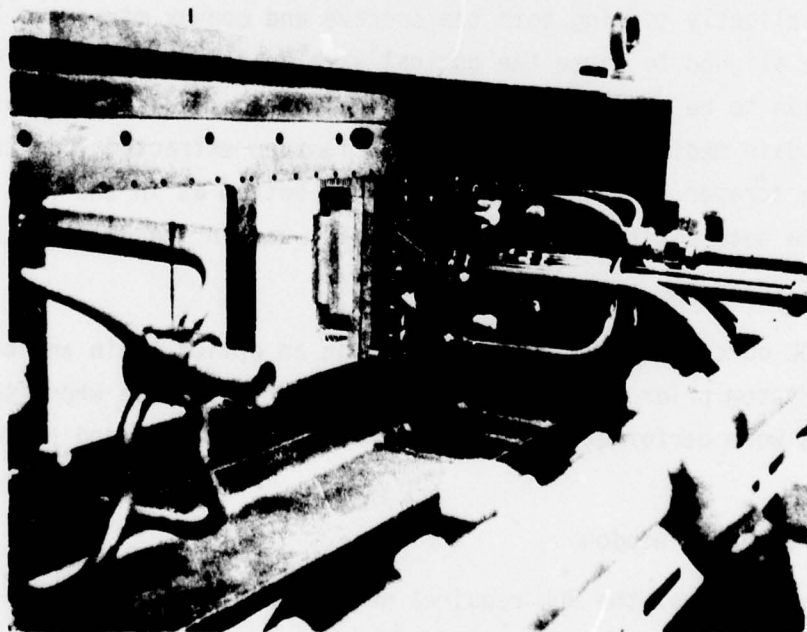

Figure 6. Front View of One BDL Module

system will pump BDL flow rates while maintaining a low pressure in the 6-foot duct of 25 torr or less.

Laser reaction products of HF, He, DF, and D<sub>2</sub> (and the aerodynamic window nitrogen flow) are pumped through the first stage of the steam ejector into the condenser. Discharge of the first stage flows into the ejector condenser where cold water condenses the steam and condensable gases (HF and DF). Noncondensable gases such as He, N<sub>2</sub> and D<sub>2</sub>, along with some vapor carry over from the condenser, are pumped to atmospheric pressure by the second stage of the steam ejector system. Condensed steam from the first stage, along with the condensable laser gases, flows through the barometric discharge into a reservoir. The temperature of the fluid leaving the condenser is approximately 100<sup>o</sup> to 120<sup>o</sup>F.

In the HF/DF mode, the BDL device provides a nominal broad band power level of 60 to 70 kW. Temporal fluctuations of the power output have been determined to be less than 10%.

The BDL was operated in a half mode configuration to produce an unobscured beam for this program. To achieve the half mode configuration, the optical axis of the resonator cavity is moved upward by raising the convex mirror and slightly tipping both the concave and convex mirrors. These mirrors are aligned to cause the optical axis associated with the half mode configuration to be parallel to the original optical axis and located within the gain medium. The laser energy is then extracted from the bottom part of the scraper, rather than the top and bottom as in the full mode design. The beam power for these test series was in the 38 to 45 kW level.

## 2. OPTICAL TRAIN AND COMPONENTS

The BDL outcoupled beam was put through an optics train and beam conditioning system prior to entering the BDL lower vestibule where the SABTS experiments were performed. Figure 7 shows the beam path and basic optical components.

### a. BDL Aerodynamic Window

The operation of the BDL requires near vacuum (below 10 torr) pressure in the optical cavity. Extraction and propagation of the laser energy involves a transition step from a few torr to atmospheric pressure.

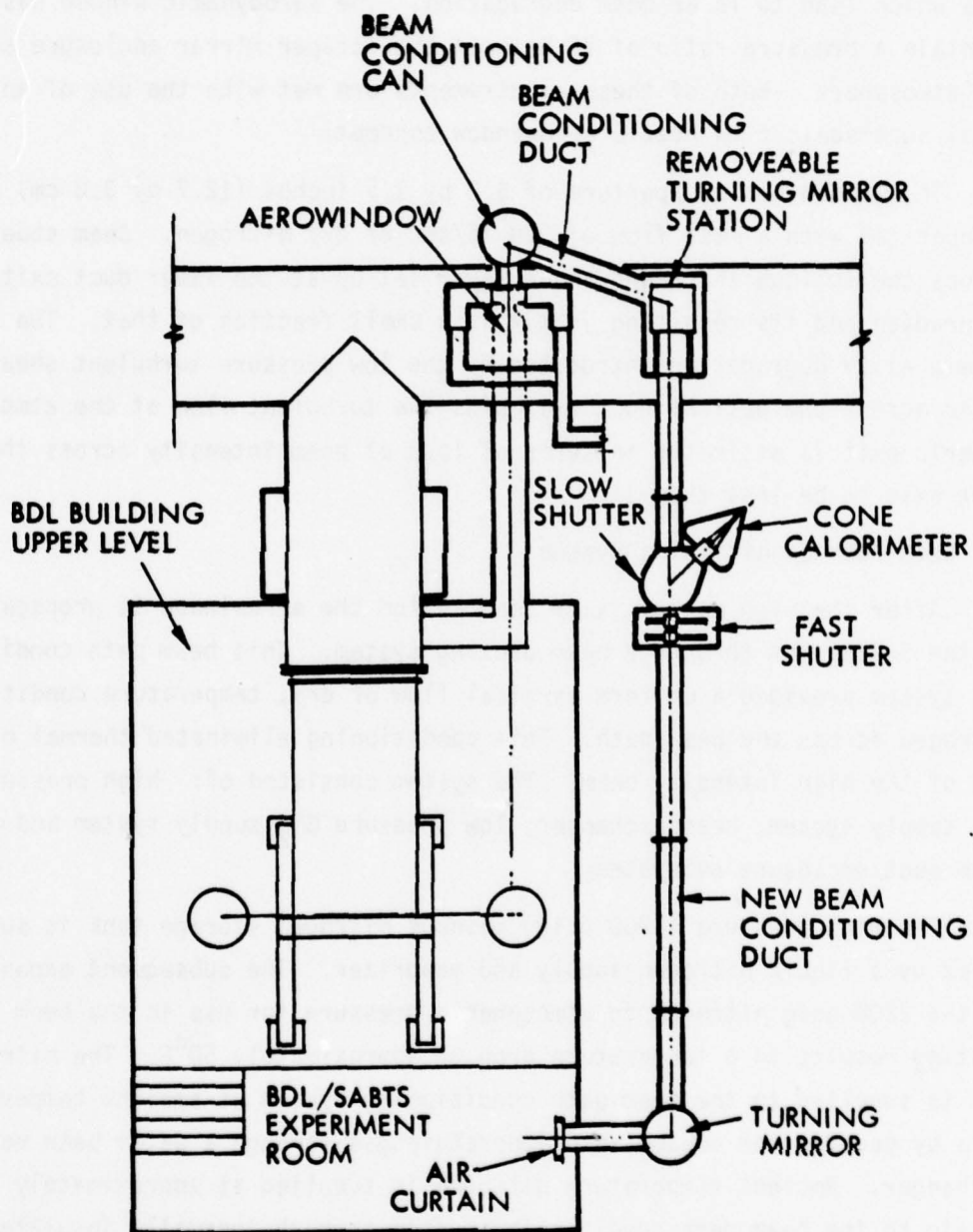

Figure 7. Beam Path and Optics Components Schematic

The principal requirement for the BDL aerodynamic window is to pass the 4.0 by 1.0-inch chemical laser beam from the low pressure laser cavity region into the atmosphere without passing through a solid window. The foremost consideration of such an aerodynamic window is to minimize problems which lead to laser beam degradation. The aerodynamic window has to maintain a pressure ratio of 76 between the scraper mirror enclosure and the atmosphere. Both of these requirements are met with the use of an axial supersonic flow nozzle aerowindow concept.

The window has an aperture of 5.0 by 1.5 inches (12.7 by 3.8 cm) and is operated with a mass flow of 3.0 lb/sec of dry nitrogen. Beam steering across the oblique shock and shear layer set up at the laser duct exit is 12  $\mu$ radian and its resulting jitter is a small fraction of that. The beam quality degradation introduced by the low pressure turbulent shear layer across the optical duct exit plus the turbulent flow at the atmospheric exit is estimated in terms of loss of beam intensity across the duct exit to be less than 1%.

#### b. Beam Path Conditioning System

After the high energy laser beam exited the aerowindow it propagated to the SABTS room through a beam ducting system. This beam path conditioning system provided a uniform vertical flow of dry, temperature conditioned, nitrogen across the beam path. This conditioning eliminated thermal blooming of the high intensity beam. The system consisted of: high pressure GN<sub>2</sub> supply system; heat exchanger; low pressure GN<sub>2</sub> supply system and a beam duct/enclosure subsystem.

The high pressure (2200 psig) gaseous nitrogen storage tank is supplied by a liquid nitrogen supply and vaporizer. The subsequent expansion of the 2200 psig nitrogen to atmospheric pressure for use in the beam ducting results in a temperature drop of approximately 50°F. The nitrogen is supplied to the beam path conditioning system at ambient temperature by passing the subambient temperature gas through a water bath heat exchanger. Ambient temperature nitrogen is supplied at approximately 2 psig to the beam path conditioning system through thermally insulated low heat capacity sheet metal ducting. The flows to each beam duct section and mirror enclosure are adjusted by means of butterfly dampers.

This passive thermal control system has resulted in a nitrogen temperature difference in the mirror enclosures and the adjacent beam ducts of  $1^{\circ}\text{F}$  or less during day or evening operations. Interferometer test results obtained on a test duct section and mirror enclosure indicated that beam quality would be seriously degraded if the temperature between the  $\text{N}_2$  in a mirror enclosure and in the adjacent beam duct section exceeded  $1.5^{\circ}\text{F}$  for the turbulence conditions existing at the enclosure/beam duct interface.

A cross section drawing indicating the features of construction of the beam duct is shown in figure 8. The nitrogen flow is down in a vertical direction across the beam. The region through which the beam passes is maintained at approximately 0.5 inch of  $\text{H}_2\text{O}$  gauge pressure by a selected filter material backed up by hardware cloth. The internal surface of the flow distribution plenum is covered with a 0.5-inch thickness of Minicel, closed cell foam insulation. The beam path duct system is shown in figure 9.

A similar  $\text{N}_2$  flow distribution system was used for the mirror enclosures. The flow is directed vertically downwards across the mirrors. Internal baffles and filter cloth are used in the enclosures to aid in directing the flow across the beam path.

The beam duct pressure of 0.5-inch  $\text{H}_2\text{O}$  gauge is obtained using an  $\text{N}_2$  curtain at the downstream end of the system, just before the SABTS. The centrifugal force generated by injecting a rectangular jet of  $\text{N}_2$  along a curved surface at an approximate velocity of 160 fps eliminates the axial flow from the beam duct. The configuration of the  $\text{N}_2$  curtain at the beam duct termination is shown in figure 10.

#### c. Beam Shutter System

The shutter system provides the capability to turn the beam off and on during the experiment to within a few milliseconds of preselected times. The enclosure for the shutter system is shown in figure 11.

The shutter must be fast acting to rapidly cut off the beam in case of sudden onset of damage, to allow minimum dead time between target changes, and further to better define damage onset levels where a rectangular shaped pulse in time is desired. For fast closing shutters, light

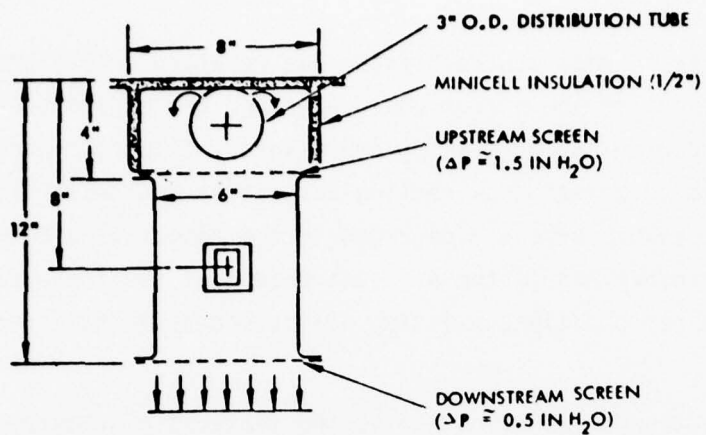

Figure 8. Cross Section of Typical Beam Duct

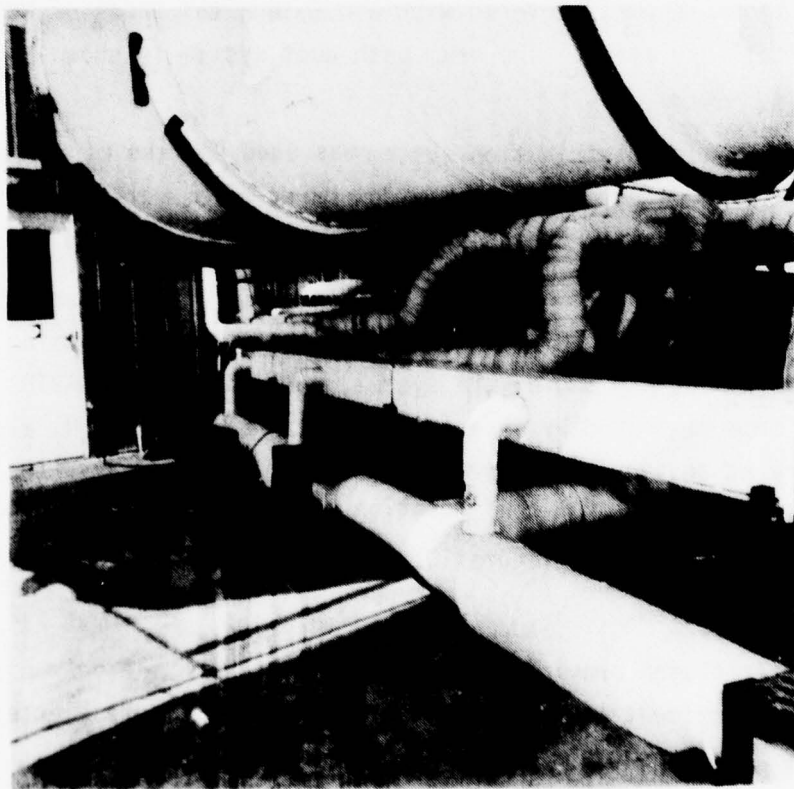

Figure 9. Beam Path Duct System

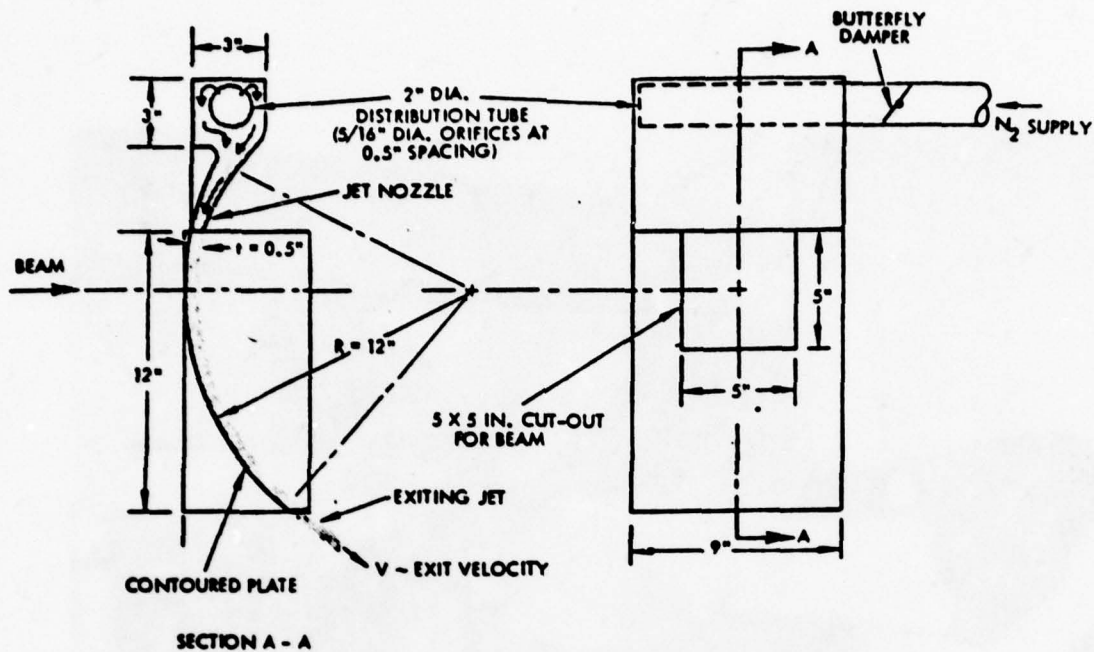

Figure 10. Configuration of  $N_2$  Curtain at Beam Duct Termination

weight is desirable. However, for long periods or continuous duty, a heavier water cooled shutter is required. To satisfy both requirements, beam control is established through the use of two shutter systems designated the slow and fast shutters, operated in conjunction with a sequencer.

The slow shutter shown in figure 12 is a pneumatically actuated, water-cooled metal mirror which can close and obscure the beam in less than 200 milliseconds. In the closed position the BDL beam is reflected into a water-cooled whole beam calorimeter, which is used to determine the primary beam power during the test runs. Since the slow shutter is designed to withstand high flux levels for extended periods of time, it is closed during a test sequence to permit resetting of the fast shutter.

The fast shutter is used to provide beam pulse intervals with fast rise and fall times. This shutter mechanism, shown in figure 13, utilizes uncooled highly reflective metal mirrors which can be rapidly translated along separate but parallel tracks. To set the fast shutter, the mirror blades are pneumatically cocked against a spring load and mechanically

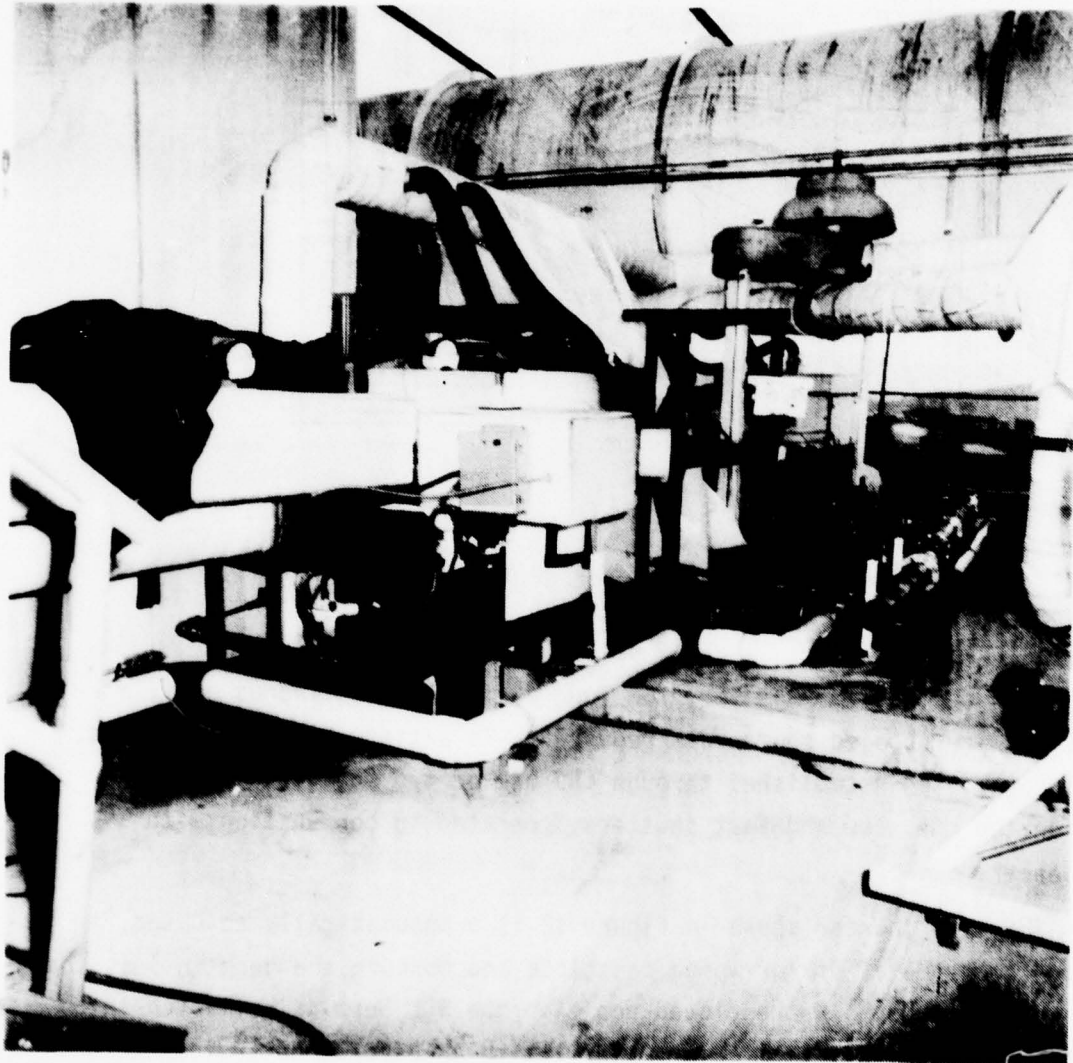

Figure 11. Shutter System Enclosure

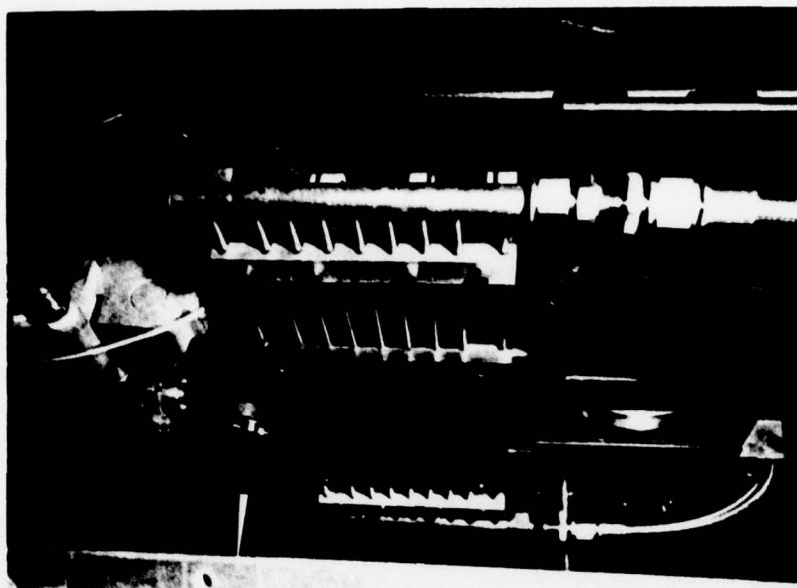

Figure 12. Slow Shutter

latched. In the cocked position, the opening blade obscures the beam. On command it is unlatched and after a 40 to 60 millisecond acceleration period is pushed out of the beam path in 5 to 10 milliseconds. After the required exposure interval, the closing blade is unlatched and the beam is completely obscured in about 70 milliseconds. As soon as the beam is completely obscured, the water-cooled slow shutter is closed to protect the fast shutter mirrors. Once the next target is in position the fast-slow shutter sequence is repeated.

#### d. Power Measurement

The absolute magnitude of the beam power for a given run is generally measured during the first and last three seconds of the run by the primary calorimeter sampling the reflected radiation from the slow shutter. A cross section of the water-cooled cone calorimeter is shown in figure 14. A photograph of the cone calorimeter as it sets in front of the slow shutter is shown in figure 15. The shallow cone angle was employed to spread the high power fluxes of the outcoupled beam over a large area and reduce the thermal loading per unit area. The power absorbed by the calorimeter is determined from measurements of the coolant water flow-rate and the

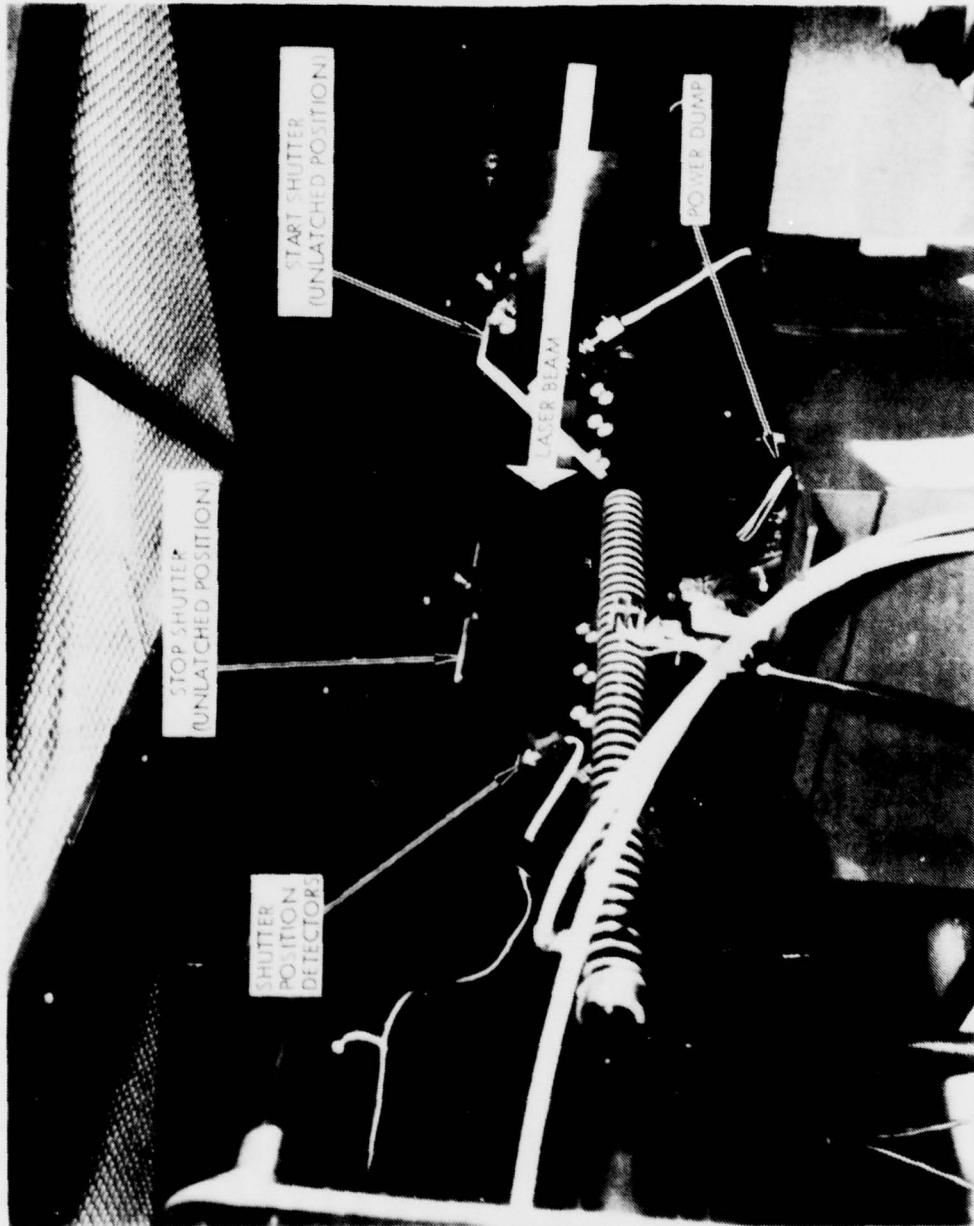

Figure 13. Fast Shutter

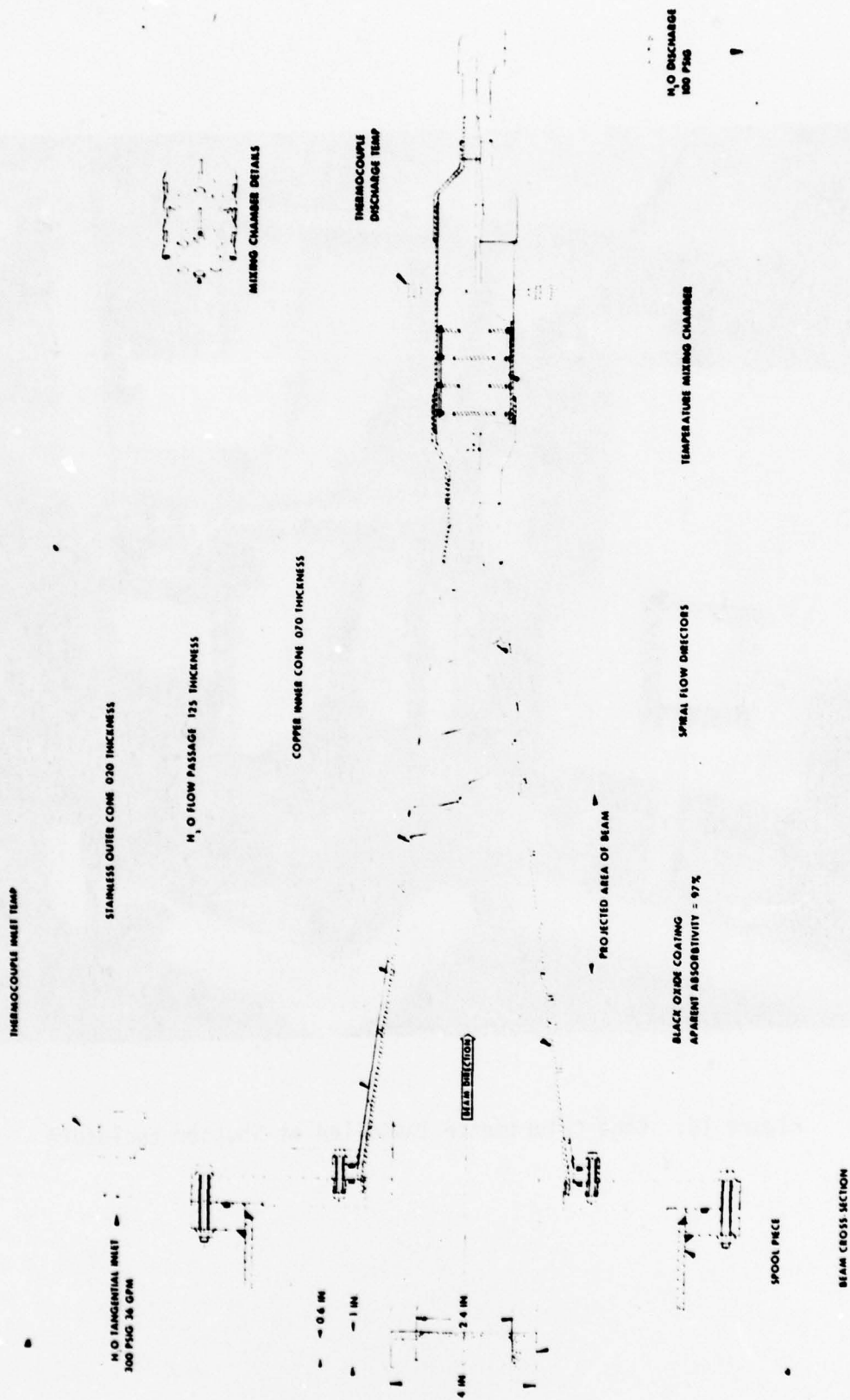

Figure 14. BDL Cone Calorimeter Schematic

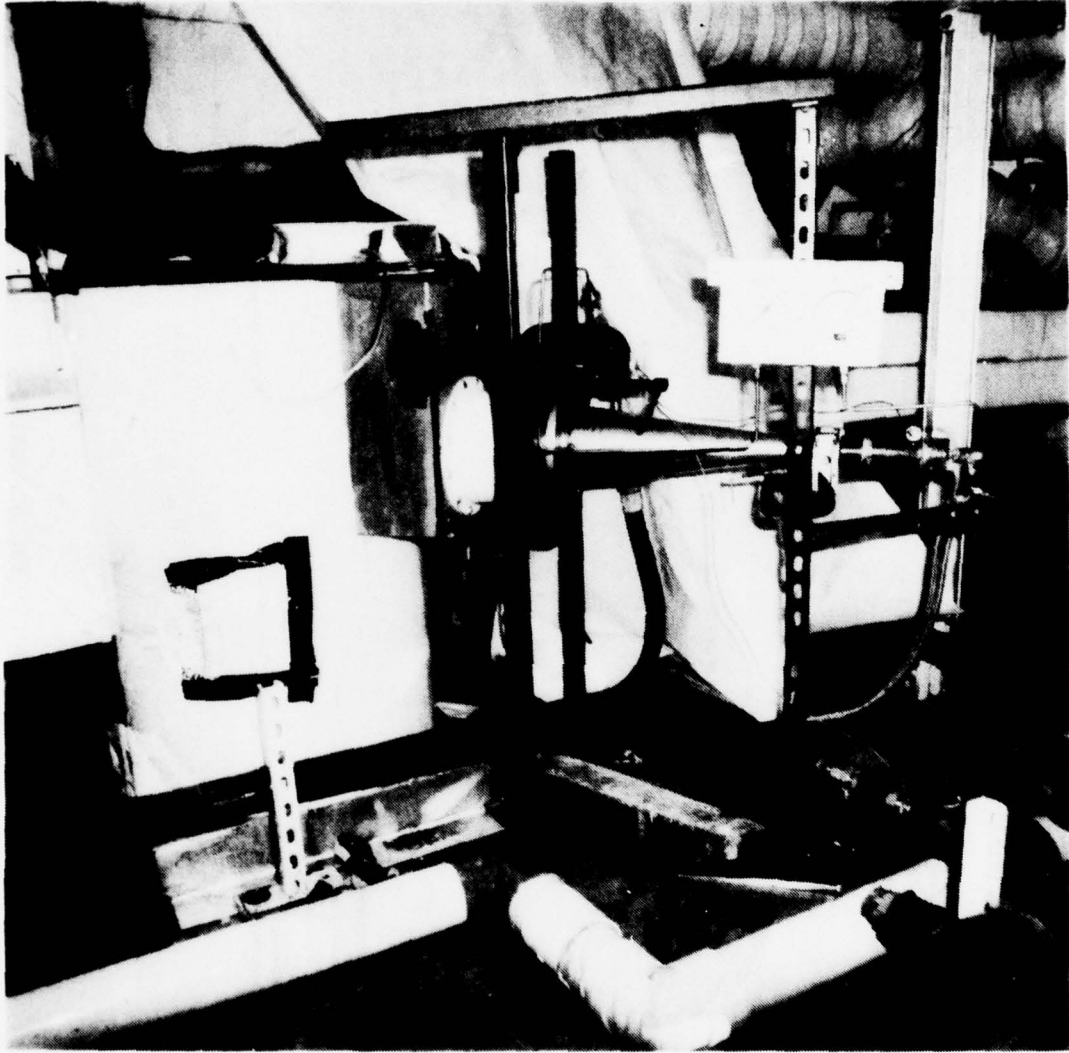

Figure 15. Cone Calorimeter Installed at Shutter Enclosure

temperature difference ( $\Delta T$ ) between the entering and exiting water. The coolant water flow-rate is measured using a calibrated turbine-type flow-meter. Typical  $\Delta T$ s measured during power tests ranged from 7 to 8<sup>0</sup>F with a coolant water flow rate of about 36 gpm.

The absolute value of power at the start of the run is used to calibrate the simultaneous signal obtained from an IR P(t) detector, which samples the scattered radiation from an upstream turning mirror. A typical P(t) relative power trace is shown in figure 16. Variations of power output as a function of time during a typical run are less than 5%.

### 3. CONTROL AND INSTRUMENTATION

Control for SABTS was provided by an interconnection of the FACC programmer-controller in the BDL annex to the remote control panel in the Main Control Center. This connection allowed for operation of required manual functions and the synchronization of the delivery of the BDL beam to SABTS. The PDP-8 was used as a programmer to automatically sequence the operation of the SABTS with the opening and closing of the slow and

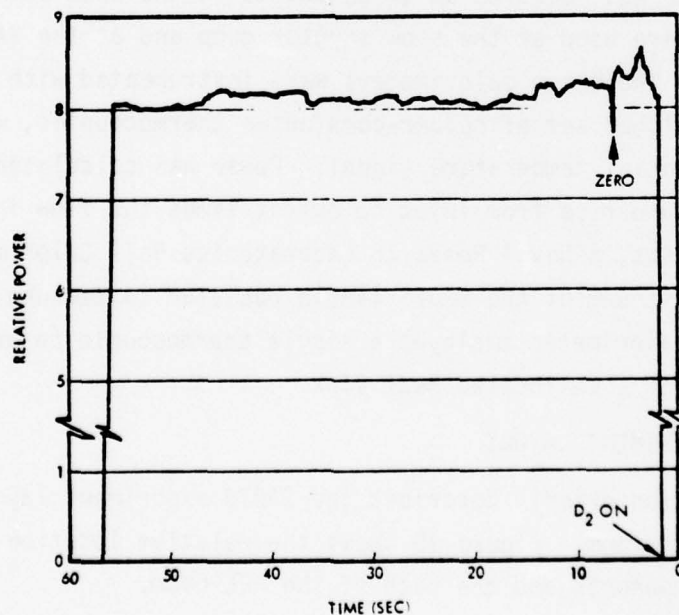

Figure 16. Relative Power vs. Time as Seen by P(t) Instrument

fast shutters. In addition, manual controls were provided adjacent to the remote control panel for override of programmed carousel positions and/or burn times. Visual indicators and/or manual controls were provided in this same area for the status of the beam control shutters, the carousel index status, and the various permit, override, and abort signals.

All signals indicated as instrumentation in figure 17 were recorded on an oscillograph to provide verification of proper function and time correlation.

Instrumentation for parameters concerning the operation of the BDL device such as pressures, temperatures, fluid flows, voltages and reactant valve operations was routed through the BDL Navy ARPA Chemical Laser and effect test shelter patch boards to the Main Control Center instrumentation patch system where it was routed to the various displays and recording systems as required per the Test Plan (figure 18). The AGA IR camera signals were patched to a high speed analog recorder for subsequent data analysis and to an oscilloscope display for real-time monitoring. This system also generated a  $P(t)$  signal for beam on correlation to TRW and SABTS instrumentation.

Beam power was measured at three points in the beam path. Cone calorimeters were used at the slow shutter dump and at the SABTS input clipper dump. These two calorimeters were instrumented with a water flowmeter and a matched set of copper-constantan thermocouples, wired to produce a differential temperature signal. Power was calculated from the water temperature rise from inlet to outlet times the flow in gpm. During some of the tests, a Naval Research Laboratories Ball Calorimeter was installed downstream of the SABTS sample position to measure power at that point. This calorimeter employed a single thermocouple to measure the temperature rise of a calibrated heat sink.

#### 4. SABTS EXPERIMENT LAYOUT

This section briefly describes the SABTS experiment layout inside of the BDL effects room. Figure 19 shows the relative location of the primary experiment components and the path of the HEL beam.

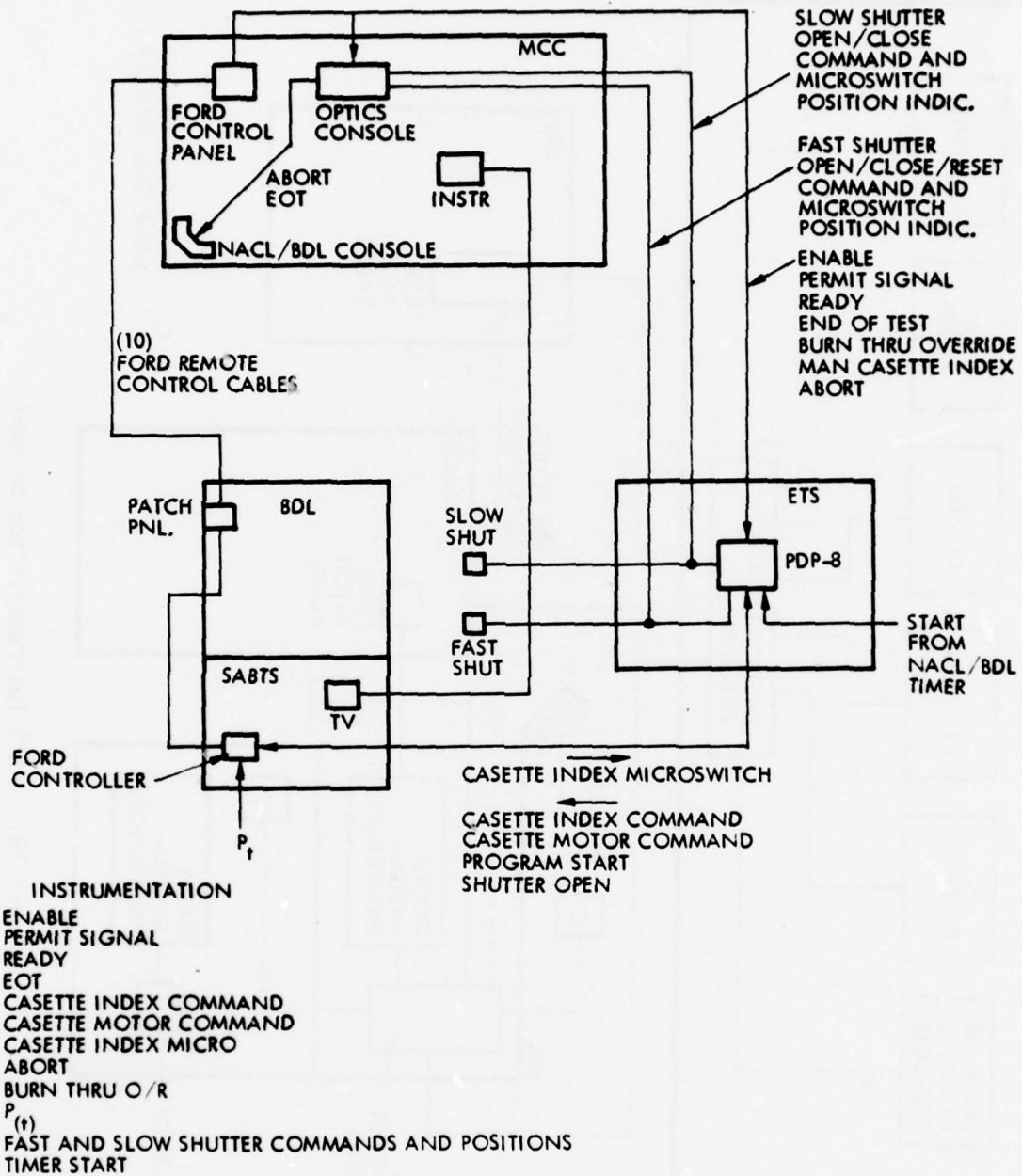

Figure 17. SABTS Control Schematic

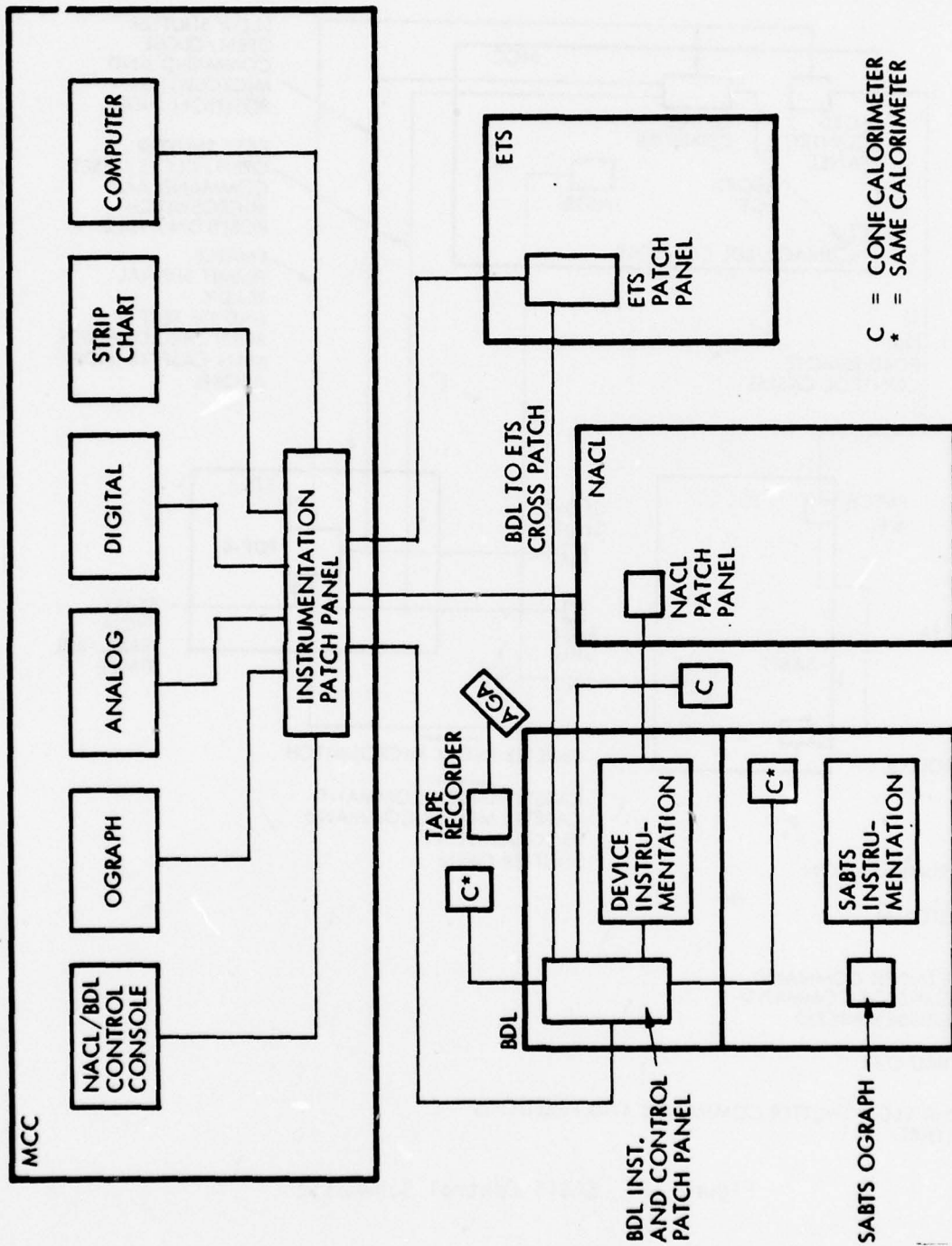

Figure 18. SABTS Instrumentation Schematic

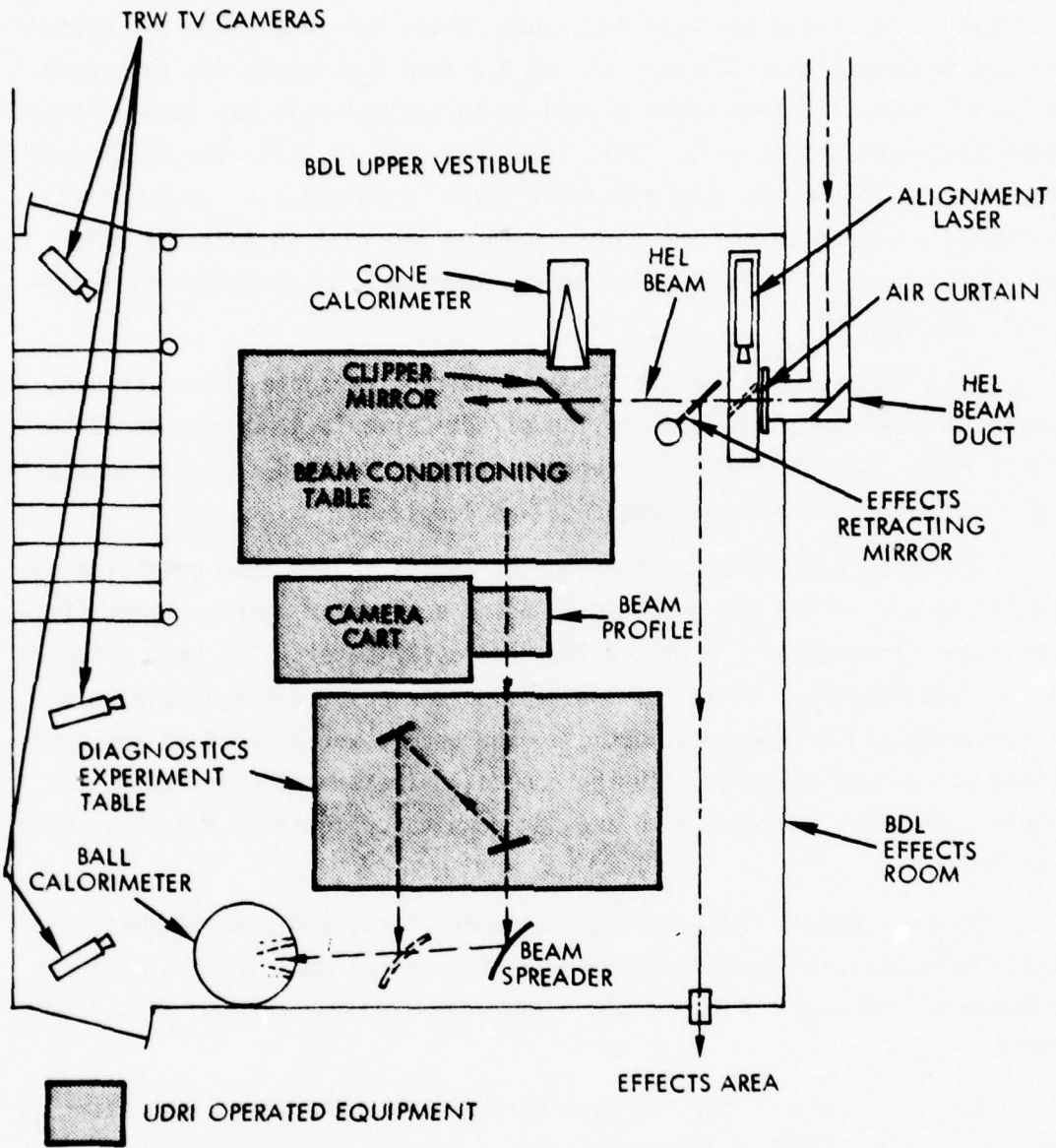

Figure 19. SABTS Experiment Layout

The HEL beam entered the BDL lower vestibule in the northwest corner from the BDL optics train (Sect. III-2). The beam passed through an air curtain as it exited the beam duct just inside the room. The air curtain served to maintain an overpressure of 0.5-inch  $H_2O$  inside the beam duct. A helium neon alignment laser placed on an optical rail was located adjacent to the beam duct exit. This laser was used to align the SABTS experiment optics to the HEL HeNe alignment beam. This was done by precisely indexing a mirror in the HEL optics path on the rail so that the HeNe beam was always coincident with the HEL beam path as described by a separate HEL HeNe beam.

Prior to entering the SABTS beam conditioning table, a copper heat sink mirror directed the beam to the effects area located outside of the SABTS room. The effects retractable mirror was removed from the beam path once the effects experiment sequence was completed.

The total power allowed through the optics in the beam conditioning table was controlled and measured by using a circular aperture beam clipper mirror in conjunction with a TRW cone calorimeter. The beam clipper mirror was located just inside the beam conditioning table as the beam entered the SABTS experiment optics. The beam power clipped by the apertured mirror was measured with the cone calorimeter and compared to the whole beam power measured with another cone calorimeter at the slow shutter position.

The beam conditioning table, the camera cart, and the diagnostics table were operated by UDRI personnel. The operational details of these components and details of the SABTS experiment itself are not described here.

The basic path of the HEL beam through the SABTS experiment stations is shown in the SABTS experiment layout figure 19. The HEL beam passed through the optics of the beam conditioning table into the diagnostics table where the primary experiment was performed. The beam profile was measured between the tables. The remaining HEL beam after it left the diagnostics table was dumped into an NRL ball calorimeter.

There were two alternate paths through the diagnostic table optics depending on whether a transmission or a reflection sample was being

irradiated. This determined the location of the beam spreader mirror positioned outside the diagnostics table. This mirror also served to spread the concentrated HEL beam to prevent damage to the ball calorimeter which might have resulted from the high beam intensities.

Also shown in the SABTS experiment layout are three television cameras. These cameras were used to visually monitor the experiment components during a test to determine the necessity of an emergency shutdown.

#### 5. EFFECTS STATION (ADD-ON EXPERIMENT)

The beam for the effects experiment was obtained as it left the beam duct in the SABTS test room and was directed outside the building through a 6- by 6-inch hole in the wall, shown schematically in figure 19. A retractable mirror mount was fabricated for the purpose of pulling the mirror (8- by 9-inch copper furnished by the Navy) from the beam path at the conclusion of the effects experiment. The mirror actuator enabled the experimenter to pull the mirror up from the beam or down from the beam. Proximity switches at either end of the stroke indicated the position of the mirror at the test console.

The basic effects area hardware included a 3- by 1-inch wind tunnel supplied by an 18 bottle farm. The wind tunnel was supplied by the Air Force Weapons Laboratory. The pressure to the dome of the regulator and air supply for the wind tunnel solenoid valve were supplied from the upstream air line to the wind tunnel.

A 24- by 24-foot canvas canopy was provided for the test area to protect equipment and instrumentation from weather. Transite sheets were situated behind turning mirrors and the target position as a safety measure. In addition, two video cameras were provided to monitor the effects experiment from the control center; one for an overall view and one to determine recording equipment readiness.

##### a. Instrumentation and Controls

The experiment instrumentation and recording equipment were supplied by the AFWL. The local experiment oscillograph, cameras, and the missile controller were turned on remotely from the control center during the count-down sequence.

Video coverage included an overall view of the experiment and a closeup of the missile controller status gauges.

The complete list of Control and Instrumentation signals is given in table 3. The PDP8 controller provided two commands: one to retract the effects director mirror in the SABTS building and the other to turn on the wind tunnel at 3 seconds prior to acquiring the beam. An interlock switch on the retractable mirror confirms mirror retraction to the computer. The experiment/test site electrical interface schematic is shown in figure 20.

Table 3. LIST OF EFFECTS EXPERIMENT TEST COMMAND AND INSTRUMENTATION SIGNALS

<u>Controls Signals</u>	
Manual:	<ol style="list-style-type: none"> <li>1. Instrumentation ON</li> <li>2. Instrumentation OFF</li> <li>3. Effects Timer Package START</li> <li>4. Effects Timer Package OFF</li> <li>5. Effects Director Mirror Retract Signal (PDP8 Override)</li> <li>6. Effects Director Mirror Manual Retract</li> </ol>
PDP8:	<ol style="list-style-type: none"> <li>1. Mirror Retract Signal</li> <li>2. Wind Tunnel Turn on (110 VAC)</li> <li>3. Mirror Interlock Feedback (in/out)</li> </ol>
<u>Instrumentation</u>	
Video coverage:	<ol style="list-style-type: none"> <li>1. 1 overall with monitor for test conductor</li> <li>2. 1 for recording equipment observation (optics console)</li> </ol>
Monitor signals:	<ol style="list-style-type: none"> <li>1. Effects Director Mirror position (optics console)</li> <li>2. Fast Shutter/slow shutter, open/close (already on optics console)</li> </ol>
Record:	P(t) (same as SABTS)

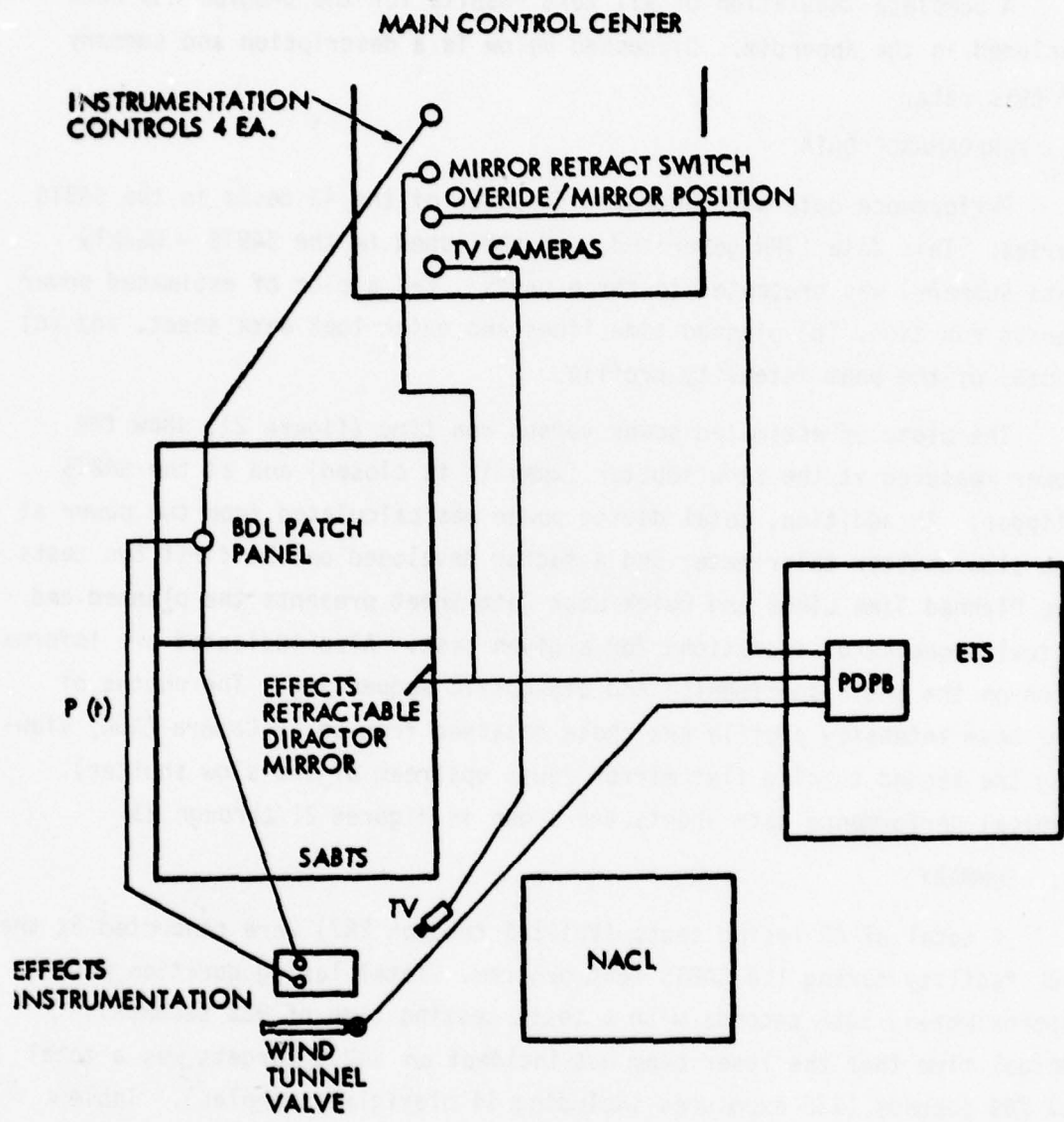

Figure 20. Effects Instrumentation/Controls Layout

## Section IV

### TEST RESULTS

A complete tabulation of all test results for the program has been included in the appendix. Discussed below is a description and summary of this data.

#### 1. PERFORMANCE DATA

Performance data was generated for each of the 43 tests in the SABTS series. This data (TRW generated, and published in the SABTS - Weekly Data Summary) was presented in three parts: (a) a plot of estimated power versus run time, (b) planned time lines and quick look data sheet, and (c) photos of the beam intensity profile.

The plots of estimated power versus run time (figure 21) show the power measured at the slow shutter (when it is closed) and at the SABTS clipper. In addition, total device power was calculated from the power at the slow shutter calorimeter and a factor developed on the first two tests. The Planned Time Lines and Quick Look Data Sheet presents the planned and actual sequence of operations for a given test. Also indicated are information on the SABTS specimen(s) and diagnostic sequencing. The photos of the beam intensity profile are those obtained from an IR Camera (AGA) viewing the second turning flat mirror (just upstream of the slow shutter). Typical performance data sheets are shown in figures 21 through 23.

#### 2. SUMMARY

A total of 43 lasing tests (VL1-245 through 287) were conducted at the BDL facility during the SABTS test program. Total lasing duration was approximately 1058 seconds with a total testing time of 922 seconds. Actual time that the laser beam was incident on SABTS targets was a total of 286 seconds (135 exposures including 14 plexiglass samples). Table 4 lists all the tests in the SABTS series and provides pertinent information as to duration, number of samples, purpose and comments. The test duration is defined as the time from combustor oxidizer ( $F_2$ ) on to cavity fuel  $D_2$  off, whereas lasing duration is from  $D_2$  on to  $D_2$  off. In most cases, the purpose of the test is indicated by the number and the exposure duration

LASER PERFORMANCE ANALYSIS - RUN NUMBER VL 1 - 270

**ESTIMATED POWER VS. TIME**

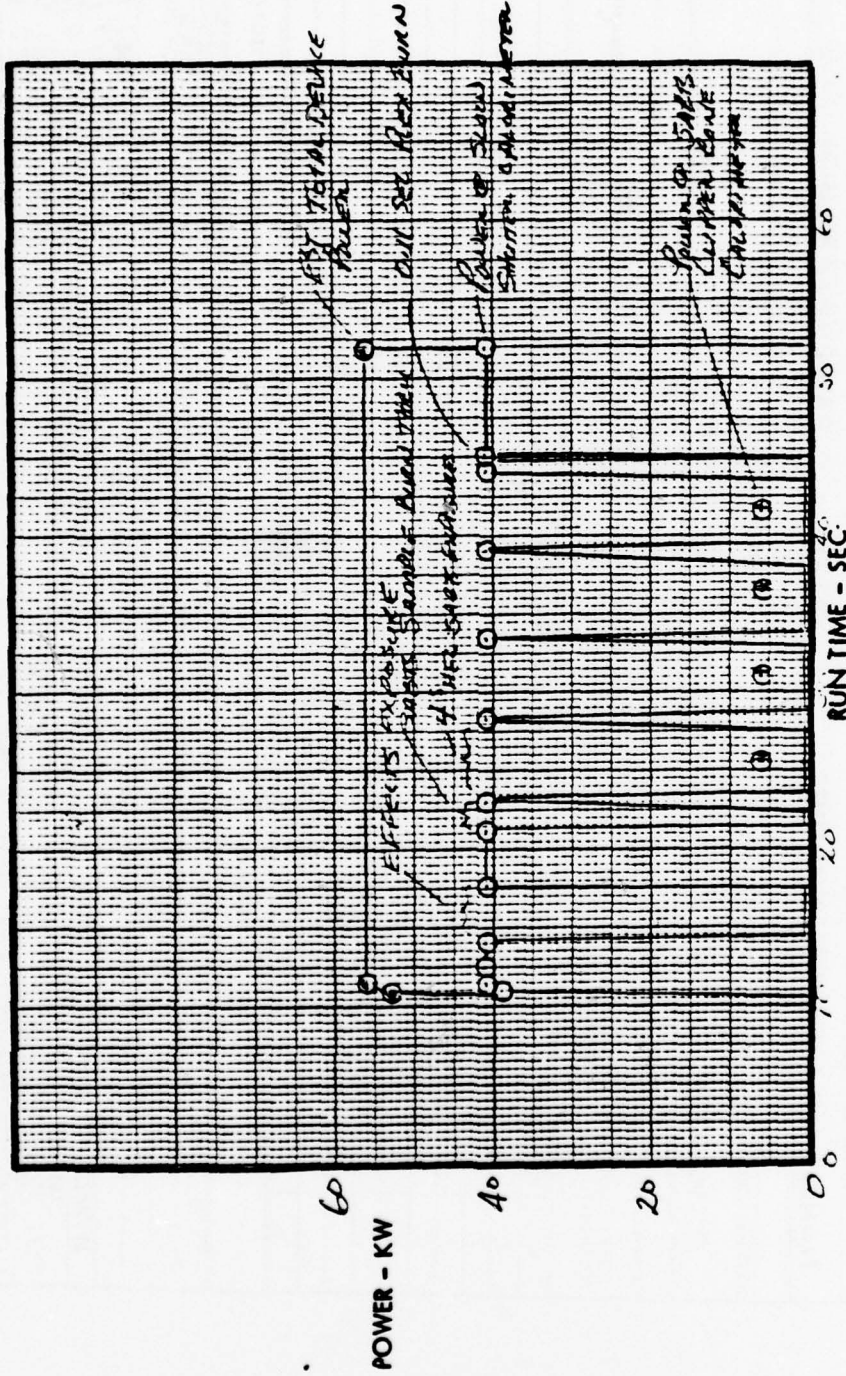

REMARKS:

PREPARED BY:

L. SINGS  
6-11-77

Figure 21. Estimated Power vs. Run Time

PLANNED TIME LINES AND QUICK LOOK DATA SHEET										
QUICK LOOK TEST DATA										
RUN NO.	TEST PLAN	DATE	TIME	PLANNED TOTAL PWR.						
VII-270	SABTS	2-10-77	1935	57						
D2 FIRE VALVE OPEN (SEC)	D2 FIRE VALVE CLOSED (SEC)	LASING DURATION (SEC)	TOTAL COMPLETED TEST POSITIONS							
10.4	51.9	41.5	7							
PLANNED TEST NO. 0617/013 TIME LINES AS OF DATE 2-10-77 REVISION 0R1G										
EXPERIMENTER		PLANNED LINEAR MAGNIFICATION		PLANNED PEAK PWR DENSITY		CONFIGURATION				
D. MULLEN		1.7		10KW/CM <sup>2</sup>		<input checked="" type="checkbox"/> REFLECTIVE <input type="checkbox"/> TRANSMISSIVE				
PLANNED					ACTUAL					
TEST POSITION	SPECIMEN NO.	COATING DESIGN	EXPOSURE TIME (SEC)	TRANSIT TIME (POST EXPOSURE)	TIME FROM F <sub>2</sub>	TIME SLICE	EST. PWR. AT TARGET	TOTAL POWER	ACTUAL SPOT DIAMETER	COMMENTS
1	PLEXI		3.0	4.5	14.00	13.0		57.2		
2										
3	* PE		4.0	1.10	21.50	20.7		56.8		
4	DOF		4.0	1.10	26.60					
5	DOF		4.0	1.10	31.70					
6	* HOUSE		4.0	1.10	36.80					
	* HOUSE		4.0	1.10	41.90					
	PLEXI		0.11		47.00	50.9		56.9		
					47.11					
ITEM	START (SEC)	STOP (SEC)	ITEM	START (SEC)	STOP (SEC)	ITEM	START (SEC)	STOP (SEC)		
TV CAMERA No. 1	ON		O-GRAPH			MON.				
No. 2	"		SANGAMO No. 1			6.0		54.0		
No. 3	"		SANGAMO No. 2			N/A				
No. 4	"		SABTS SEQ.			21.5		47.1		
WIND TUNNEL	11.0	18.00	CALORIMETER (SABTS)			21.5		47.1		
SABTS INST.			CALORIMETER (SLOW SHUTTER)			10.0		14.0		
HI FLOW SOLENOID	10.0	52.6	"	"	"	15.0		21.9		
EFFECTS MIRROR	END OF I		"	"	"	47.1		52.6		

\* PROFILFA  
Figure 22. Planned Time Lines and Quick Look Data Sheet

BEAM INTENSITY PROFILE

AS SEEN BY IR CAMERA VIEWING SECOND TURN FLAT

TOTAL INTENSITY  
APPROX. TIME (SEC) 20

LINEAR PROFILE\*  
APPROX. TIME (SEC) 20



LEE BERGERSON  
BEAM DIAGNOSTICS ENGINEER

Figure 23. Beam Intensity Profile

Table 4. RUN LISTING

Test Number VLI-	Date	Test Duration (sec)	Lasting Duration Planned (sec)	Lasting Duration Actual (sec)	Samples Planned	Samples Actual	Purpose	Comments
245	1-7-77	22.7	8.7	8.7	0	0	Checkout	
246	1-11-77	45.8	35.8	35.8	2	2	Checkout/Alignment	F <sub>2</sub> scan samples were plexiglass and Transite
247	1-13-77	27.3	16.9	16.9	6	0	Checkout/Alignment	Slow shutter did not open. Samples were plexiglass
248	1-14-77	27.3	16.9	16.9	6	0	Checkout/Alignment	Burn wire termination. SABTS test at 1st position
249	1-18-77	14.5	25.0	4.1	1	0	Checkout/Alignment	Alignment prism exposed to beam.
250	1-18-77	37.6	27.2	27.2	1	1	Checkout/Alignment	Manual S/D, low power
251	1-19-77	37.8	27.4	27.4	1	1	Checkout/Alignment	F <sub>2</sub> scan power remains low on plexiglass sample
252	1-21-77	24.8	18.0	14.4	6	1	1st SABTS Checkout	Mirrors realigned. Pretest power backup
253	1-21-77	17.6	7.2	7.2	1	1	SABTS Checkout	F <sub>2</sub> scan completed.
254	1-22-77	24.3	13.9	13.9	6	6	1st SABTS Specimen	SABTS spider burn through plex samples
255	1-24-77	24.1	13.7	13.7	6	6	6/.25 <sup>s</sup> exposures	Plex sample
256	1-24-77	46.8	36.9	36.9	6	6	6/4 <sup>s</sup> exposures	
257	1-26-77	24.2	13.8	13.8	6	6	6/.25 <sup>s</sup> exposures	
258	1-26-77	46.8	36.4	36.4	6	6	6/4 <sup>s</sup> exposures	
259	1-26-77	24.2	13.8	13.8	6	6	6/.25 <sup>s</sup> exposures	
260	1-27-77	24.2	13.8	13.8	6	6	5/.25 <sup>s</sup> + 1/.05 <sup>s</sup> Plex	
261	1-27-77	46.7	36.3	36.3	6	6	6/4 <sup>s</sup> exposures	Last sample burned through < 1 sec
262	1-28-77	24.3	13.9	13.9	6	0	6/.25 <sup>s</sup> + 1/.11 <sup>s</sup> Plex	Slow shutter did not open
263	1-28-77	24.2	13.8	13.8	6	6	5/.25 <sup>s</sup> + 1/.11 <sup>s</sup> Plex	
264	1-28-77	42.7	32.3	32.3	6	6	5/4 <sup>s</sup> + 1/.11 <sup>s</sup> Plex	
265	1-28-77	42.5	32.1	32.1	6	6	5/4 <sup>s</sup> + 1/.11 <sup>s</sup> Plex	End of Phase II

Table 4. RUN LISTING (Continued)

Test Number VLI-	Date	Test Duration (sec)	Leasing Duration Planned (sec)	Leasing Duration Actual (sec)	Samples Planned	Samples Actual	Purpose	Comments
266	2-8-77	23.2	12.8	12.8	2	2	Checkout and Alignment	3.5 <sup>s</sup> exposure to thermal trap (SABTS) 2 exposure to Plex
267	2-8-77	23.2	12.8	12.8	2	2	Checkout and Alignment	3.5 <sup>s</sup> exposure to thermal trap (SABTS) 2 exposure to Plex
268	2-9-77	52.4	42.0	42.0	6	6	5/4 <sup>s</sup> + 1/.11 <sup>s</sup> Plex	~1 <sup>s</sup> Plex exposure at effects station
269	2-9-77	39.6	43	29.2	6	3	5/4 <sup>s</sup> + 1/.11 Plex	3.0 exposure to effects Test aborted - UDRI calorimeter fire
270	2-10-77	51.9	41.5	41.5	6	6	5/4 <sup>s</sup> + 1/.11 <sup>s</sup> Plex	2nd sample burn through 3 sec effects (Plex)
271	2-10-77	52.4	42.0	42.0	6	6	5/4 <sup>s</sup> + 1/.11 <sup>s</sup> Plex	1st sample burn through
272	2-11-77	52.4	42.0	42.0	6	6	5/4 <sup>s</sup> + 1/.11 <sup>s</sup> Plex	3 sec effects exposure
273	2-15-77	40.7	42.0	30.3	6	5	5/4 <sup>s</sup> + 1/.11 <sup>s</sup> Plex	3 sec effects exposure 4 samples burn through - Test term after 5th sample
274	2-16-77	40.7	36.0	30.3	5	1	4/4 <sup>s</sup> + 1/.10 <sup>s</sup> Plex	Reflective samples 3 sec effects exposure Carousel failed to index
275	2-17-77	26.8	38.0	16.9	5	0	4/4 <sup>s</sup> + 1/.10 <sup>s</sup> Plex	3 sec effects exposure Effects miro dropout - no SABTS exposures
276	2-17-77	49.3	38.0	24.6	5	3	4/4 <sup>s</sup> + 1/.10 <sup>s</sup> Plex	1 sec effects exposure (Plex) Lost power during 3rd SABTS sample - F <sub>2</sub> depletion
277	2-22-77	33.0	22.6	22.6	1	0	1/4 <sup>s</sup>	2/3 sec effects exposure No SABTS exposure - fast shutter not reset
278	2-23-77	30.9	23.0	20.5	1	1	1/4 <sup>s</sup>	No effects attempted. 2.2 <sup>s</sup> exposure to SABTS
279	2-24-77	33.0	23.1	23.1	1	1	1/4 <sup>s</sup>	2/3 <sup>s</sup> effects exposure
280	2-24-77	33.0	22.6	22.6	1	1	1/4 <sup>s</sup>	2/3 <sup>s</sup> effects exposure
281	2-25-77	32.5	22.6	22.6	1	1	1/4 <sup>s</sup>	2/3 <sup>s</sup> effects exposure
282	2-26-77	32.5	22.6	22.6	2	2	1/4 <sup>s</sup> + 1/.1 <sup>s</sup> Plex	1/3 <sup>s</sup> 1/2 <sup>s</sup> effects exposure
283	2-26-77	36.6	26.7	26.7	2	2	1/4 <sup>s</sup> + 1/.1 <sup>s</sup> Plex	1/4 <sup>s</sup> 1/5 <sup>s</sup> effects exposure
284	2-27-77	49	42	40.9	5	5	4/4 <sup>s</sup> + 1/.1 <sup>s</sup> Plex	1/6 <sup>s</sup> 1/3 <sup>s</sup> effects exposure F <sub>2</sub> premature shutdown
285	2-28-77	54.5	45	44.1	6	6	5/4 <sup>s</sup> + 1/.1 <sup>s</sup> Plex	2/3 <sup>s</sup> effects exposure
286	2-28-77	34.5	24.6	24.6	2	2	1/4 <sup>s</sup> + 1/.1 <sup>s</sup> Plex	2/3 <sup>s</sup> effects exposure
287	3-1-77	44.7	45	34.8	6	6	5/4 <sup>s</sup> + 1/.1 <sup>s</sup> Plex	3 SABTS samples override after ~1 <sup>s</sup> samples

of the sample; i.e.,  $6/.25^S + 1/.11^S$  plex means six SABTS samples each exposed to the HEL beam for 0.25 seconds plus a plexiglass sample exposure for 0.11 seconds. During the later portion of testing (VL1-266 and subsequent - Phase III) the HEL beam was also directed at various effects specimens (add-on experiment) in addition to the SABTS exposures. Some device/optics related problems were experienced during the initial phase of testing (VL1-245 through 250); i.e., cavity misalignment, failure to retract alignment periscope, and the slow shutter not opening. Test VL1-251, which featured an  $F_2$  scan to characterize the device, was the last test after which no major adjustments were made to the device or the optical train. Following test 251 only minor adjustments were made in reactant flow rates and optical alignment to maintain device power (as measured at the slow shutter calorimeter) above the 36 kW allowed minimum.

## Section V

### DISCUSSION OF RESULTS

#### 1. TECHNICAL PERFORMANCE SUMMARY

##### a. Power Performance

The off-axis mode of cavity alignment (Section III) produces an exiting beam with protruding edges ("fangs"). These edges are removed at the fang clipper producing a square shaped beam. For the first two tests (VLI-245, 246) a cone calorimeter was located at the fang clipper as well as at the slow shutter. Thus, power was measured at the slow shutter and at the fang clipper and total power was calculated from the sum of the two. On subsequent tests the cone calorimeter at the fang clipper was moved to the clipper in the SABTS test area (the fangs were still being clipped but this power was now being dumped into a noninstrumented graphite block).

Figure 24 is a plot of power versus test number showing both the total device power (estimated from the third test to the end of the series) and the SABTS "delivered" power (at the slow shutter calorimeter). Power at the fang clipper calorimeter is also shown for the first two tests. The first seven tests in the program were essentially checkout and reactant ( $F_2$ ) scans to determine device characteristics. Some difficulties were experienced during these tests related to cavity misalignment and human error. However, once exposures to SABTS sample began (with test VLI-252), delivered power did not drop below the minimum program requirement of 36 kW. One power drop caused by premature depletion of  $F_2$  did occur during run VLI-276.

Delivered power (as measured at the slow shutter when the slow shutter is closed) was determined just before and just following SABTS exposure(s) and the values plotted in figure 24 are those averaged for a particular test. Average delivered power was 42.1 kW ( $\sigma = 1.36$  kW) for tests VLI-252 through -287 with a maximum of 44.1 and a minimum of 37.6 kW. It should be noted that this minimum value of 37.6 kW is  $> 3\sigma$  below the average value. In fact, on the test (-273) where the lowest value occurred, flow rates were inadvertently set such that a low available F rate ( $\dot{N}_F$ ) and a low  $F_2$

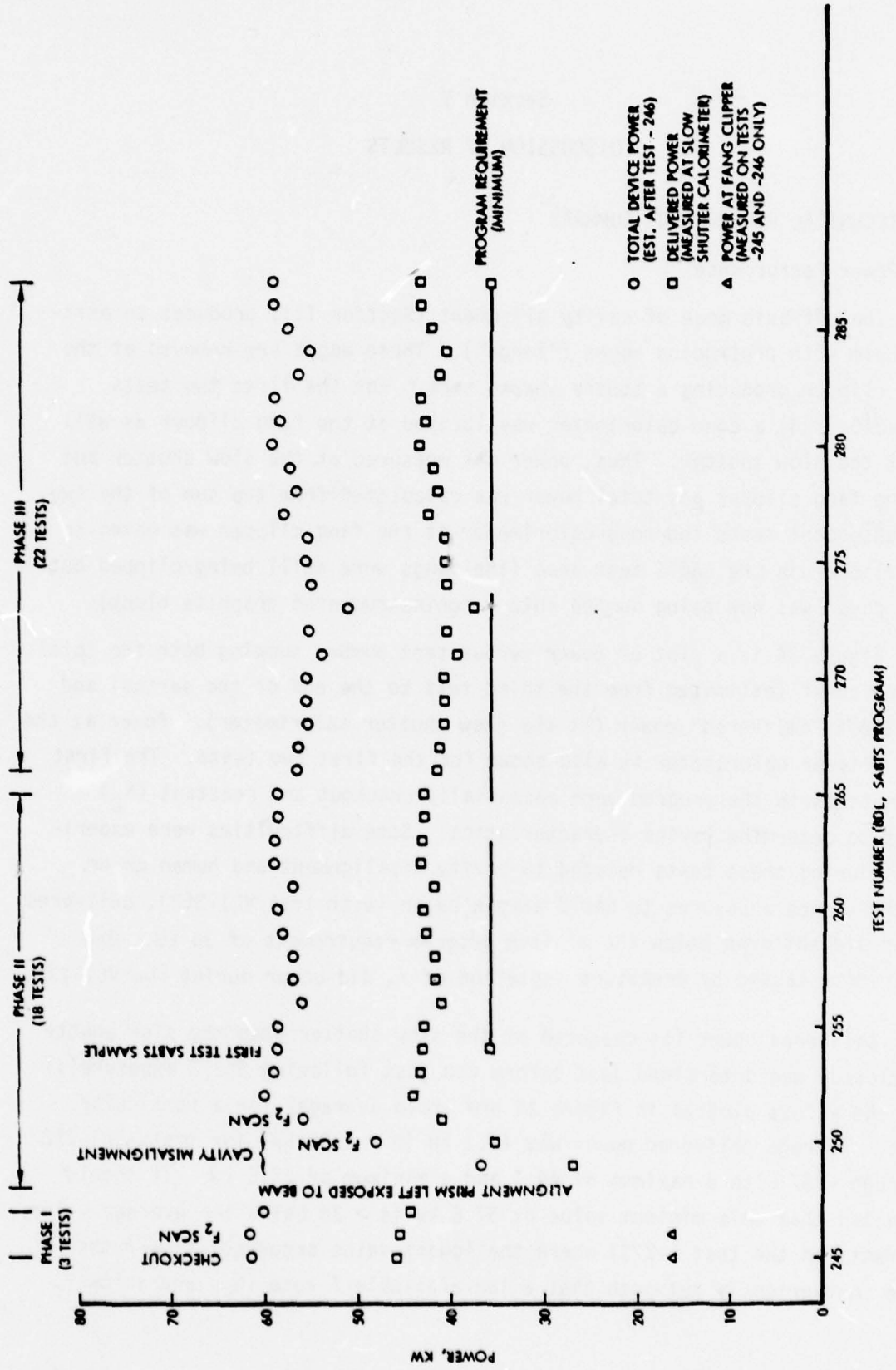

Figure 24. Power vs. Test Number

mass rate coincided to cause the low power. If the value of 37.6 kW is statistically eliminated, average power would be 42.2 with a standard deviation ( $\sigma$ ) of 1.14, indicating fairly consistent device power delivery.

b. Optical Performance

The beam size was determined several ways. First, a TRW EMBLAZONU code computer calculation was used to predict the beam profile during the designing stages. A SABTS clipper having a 3.5 cm diameter hole normal to the beam was considered in these calculations. The prediction of beam power and irradiance passing through the hole, and that being reflected by the clipper are shown in table 5. The calculations predicted 24% of the beam would be clipped and 76% would pass through the SABTS clipper.

Table 5. DATA FROM CALCULATIONS BASED ON EMBLAZONU COMPUTER PLOTS

	<u>SABTS Clipper</u>
Total Power to Clipper (kW) (assumed)	50.0
Power through Clipper Hole (kW)	38.0
Power Dumped by Clipper (kW)	12.0
Maximum Irradiance at Clipper (kW/cm <sup>2</sup> )	12.5
Average Irradiance through Clipper Hole (kW/cm <sup>2</sup> )	3.9

The major method of determining beam size measured through many continued runs was obtained by snapshot imaging of the scattered HEL radiation from the second turning flat mirror at different times into the run using an AGR IR camera. Representative contour and three-dimensional plots are shown in figures 25 and 26. In particular figure 25 shows intensity contours of the beam. Numbers seen in the figure on each countour line indicate percentages of the maximum intensity. Using a 20% cutoff of the contours, beam heights for various runs are presented in figure 27. Allowing for mirror tilt, all widths were equal to or less than the heights, permitting more than the calculated fraction of the beam to pass through the 3.5 cm diameter SABTS clipper.

# BDL/SABTS TESTING - AGA

VLI-249 18 JAN 1977

TIME = 13.0 SEC

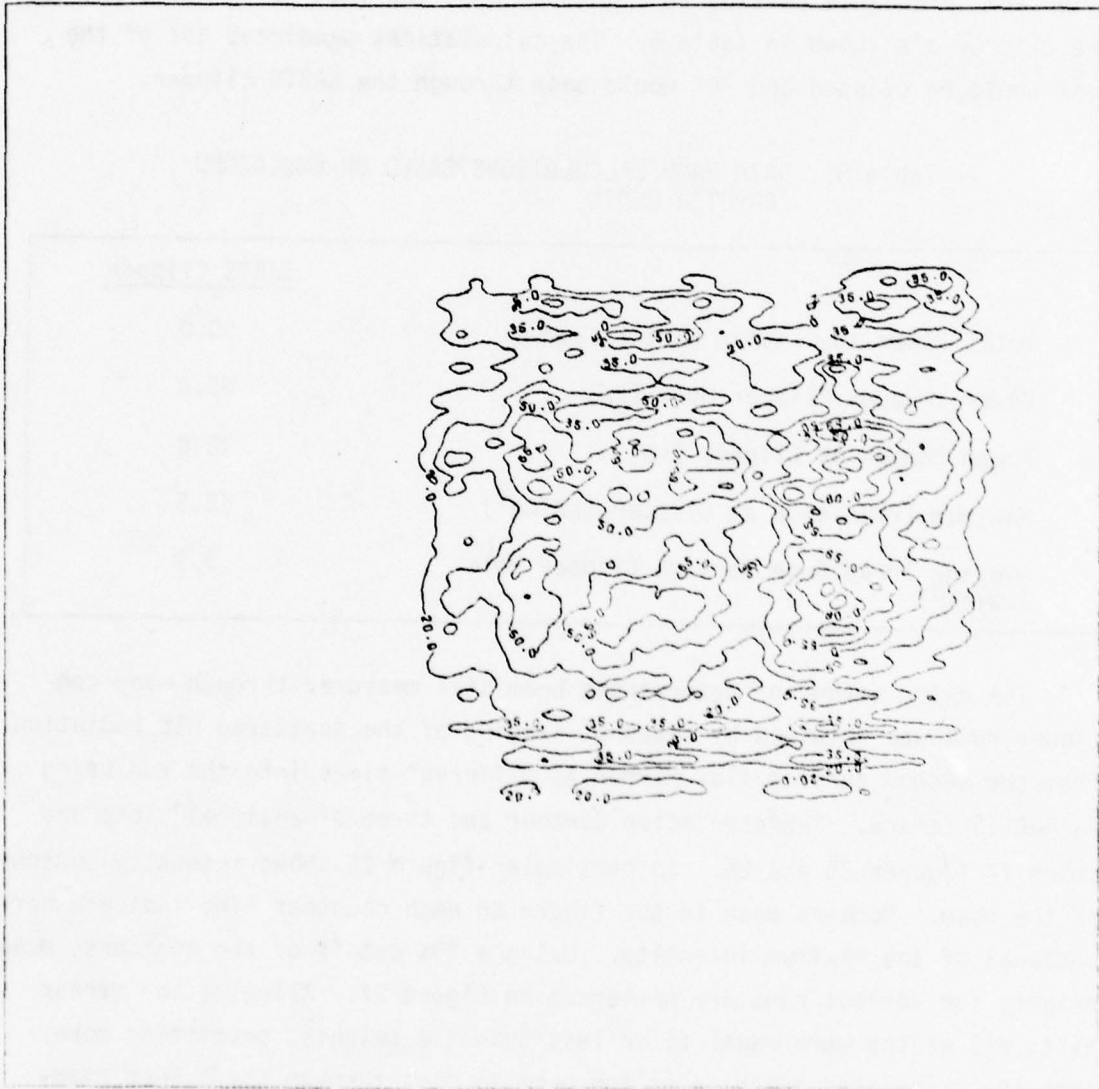

Figure 25. AGA Contour Plot of HEL Beam on Second Turning Mirror

# BDL/SABTS TESTING - AGA

VL1-249 18 JAN 1977

TIME - 13.0 SEC

TIME - 13.0 SEC

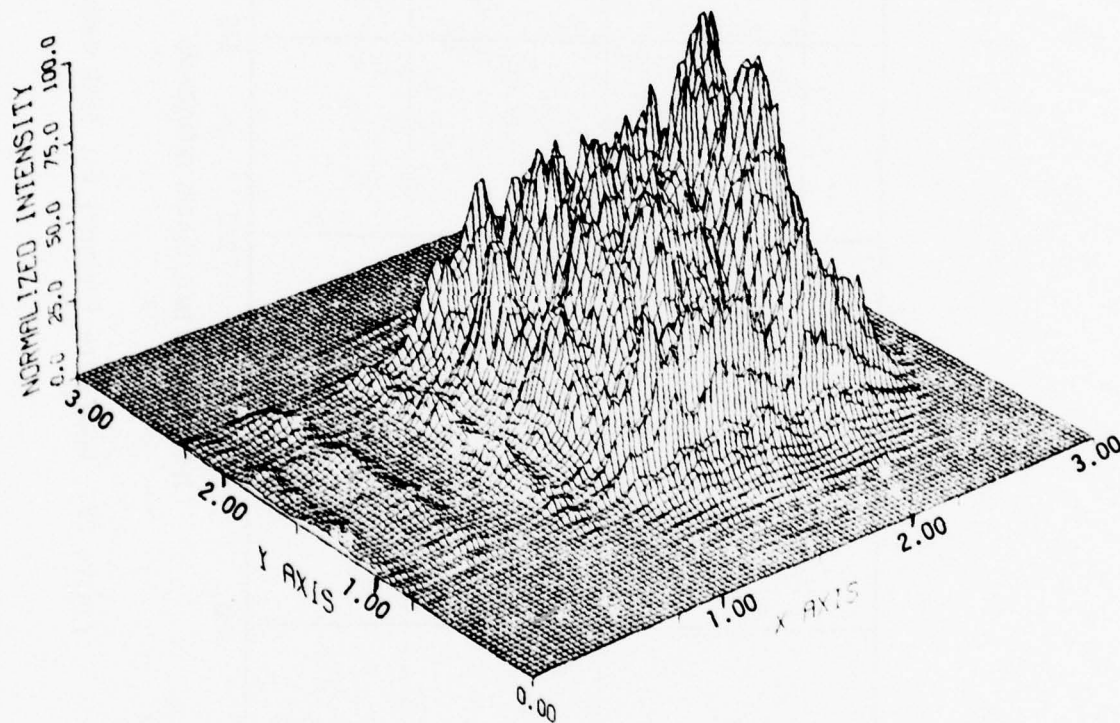

Figure 26. AGA 3-D Plot of HEL Beam Profile on Second Turning Mirror

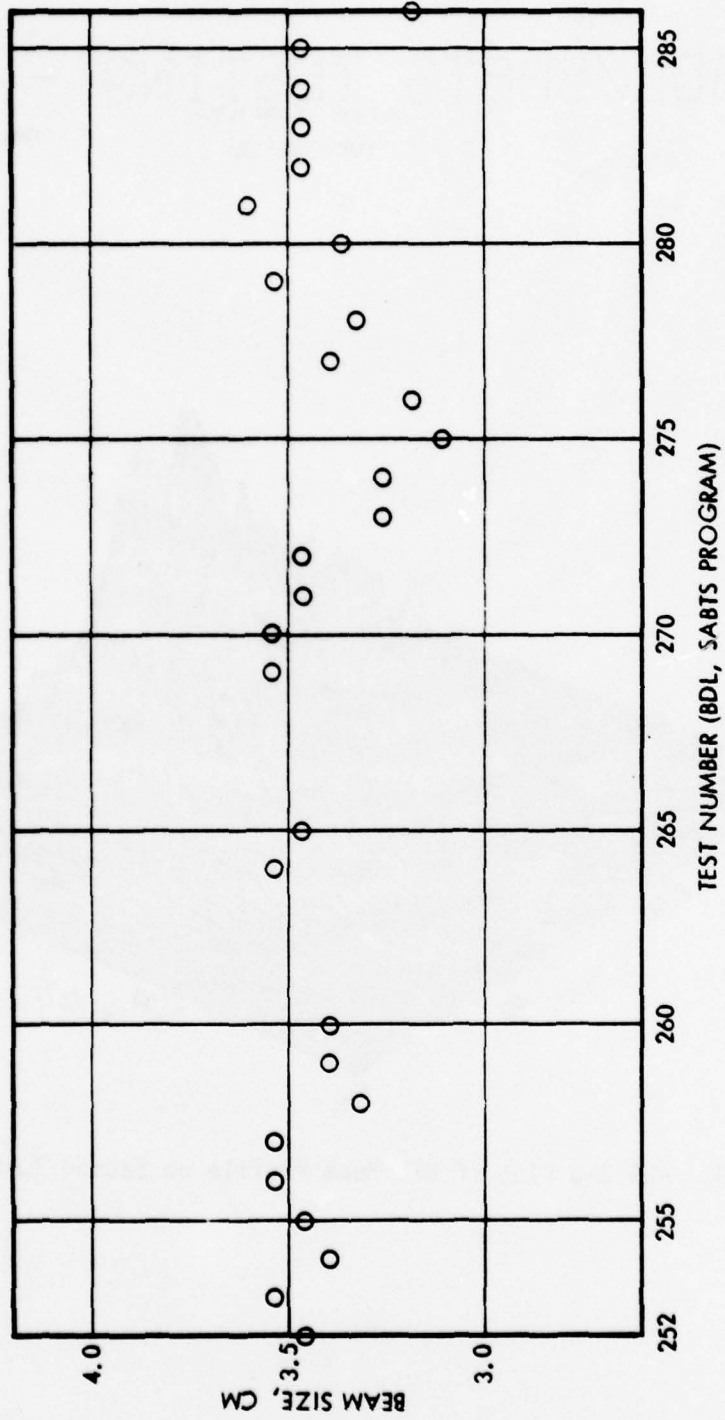

Figure 27. Beam Size (Height) vs. Test Number

A second measurement of beam size was made by measuring the amount of power reflected from the SABTS clipper into the BDL cone calorimeter and ratioing this to the total incident power on the clipper. These ratios for the various runs are presented in figure 28. They ranged in value from 0.13 to 0.26. The average ratio for the various points is 0.184. This is slightly better than the 0.24 fraction predicted by the EMBLAZONU calculations.

The third method of checking the beam size was made with an etching burned into a plexiglass sample by the HEL beam at the entrance to the SABTS beam conditioning cart. Measurements on the size of the etching, shown in figure 29, indicate the beam size to be 3.5 cm.

In addition to beam size, beam alignment was repeatedly monitored. Once the HeNe laser beam was aligned with the HEL beam via a plexiglass burn etching, subsequent checks of the BDL-SABTS optical train were made daily using the HeNe alignment beam. Additional checks were made whenever indicated. Further monitoring of the beam path was made from run to run by checking for any possible movement of the AGA HEL image. Additionally, continuous monitoring of the beam alignment was made by observing the clipped beam power from the SABTS clipper. Had misalignment occurred, it would have resulted in a sizeable increase in the clipped beam power. In general, the beam remained steady and little, if any, trimming of the optical train was required.

## 2. TEST OPERATIONS SUMMARY

Figures 30 and 31 summarize the SABTS operations and provide a quick comparison of program objectives with test accomplishments. In particular, figure 30 compares the estimated number of samples planned for testing with the number of samples that were actually irradiated. Test objectives for Phases II and III were 74 and 40 samples respectively for a total program objective of 114 specimens. Altogether, a total of 148 separate test opportunities were provided to SABTS. These test opportunities are defined as those planned specimen tests for which the HEL beam was fully available to the test system. From these opportunities, a total of 135 samples were actually tested by the SABTS. Differences between sample test opportunities

RATIO OF CONE CALORIMETER POWER VS TEST NUMBER  
 $\left( \frac{\text{SABTS CLIPPER}}{\text{SLOW SHUTTER}} \right)$

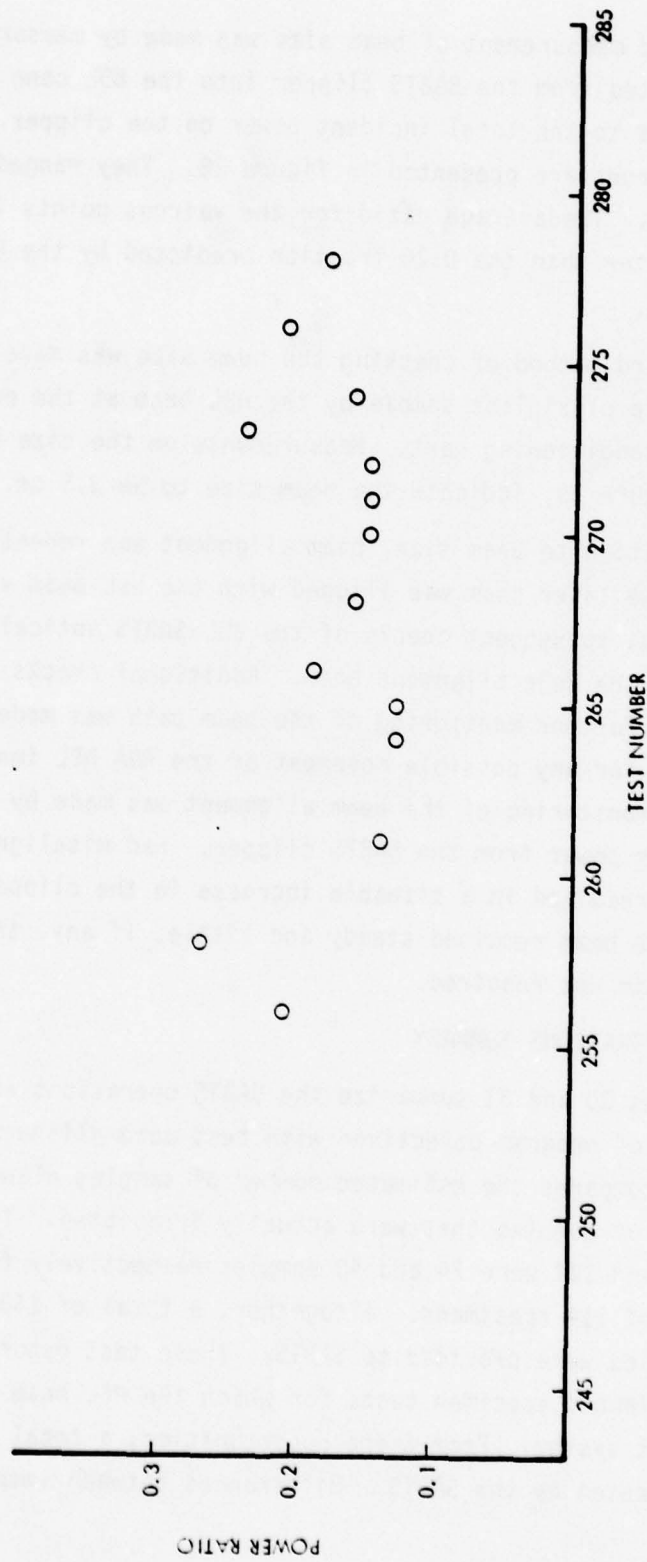

Figure 28. Power Ratio vs. Test Number

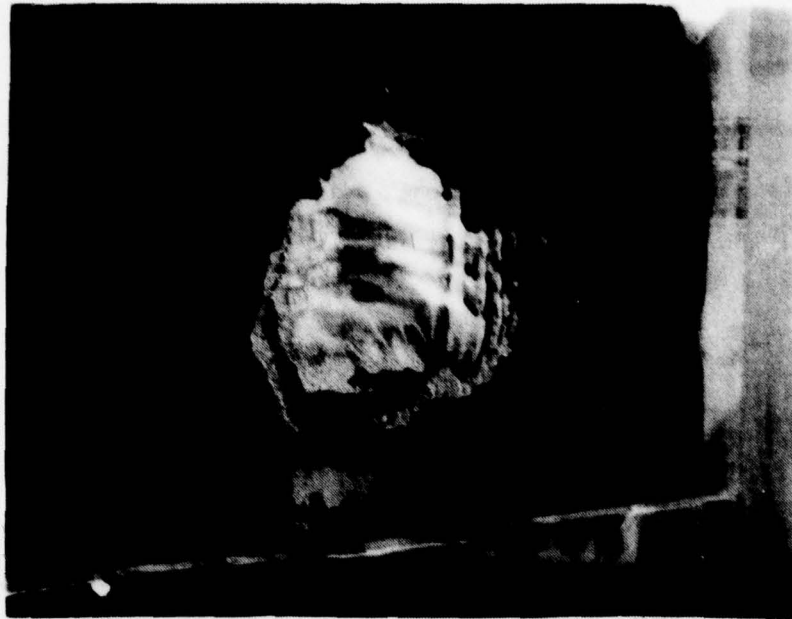
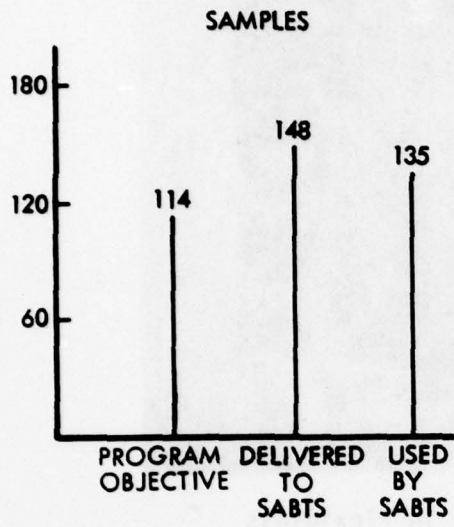

Figure 29. HEL Beam Etching in Plexiglass Sample

delivered to SABTS and sample test opportunities used by SABTS were caused by sample overrides or test shutdowns triggered by the SABTS itself. In any case, the total number of specimens actually tested was greater than had been planned.

Figures 30b and 30c make similar comparisons between the test objectives and test results for total time-on-target and total lasing device time. Figure 30b plots the total amount of time the specimens were irradiated while Figure 30c shows the total amount of time the BDL device was lasing. Once again, both parameters significantly exceeded the program objectives.

Figure 31 plots total number of laser runs as another parameter of test performance. At the beginning of the program, the test objectives included 42 single specimen runs and 12 multiple specimen runs for a total of 54 runs. The number of single versus multiple specimen runs was continually revised during the course of testing with a final end result of 25 multiple and 11 single specimen runs. This resulted in a total of 36 successful runs. However, since more multiple specimen runs were completed, the total number of specimens actually tested was greater than had been



(a)

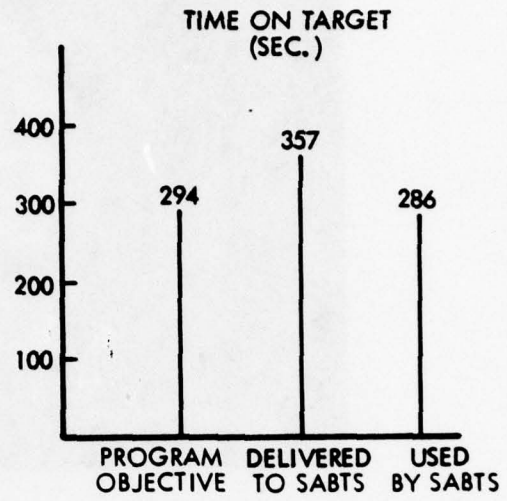

(b)

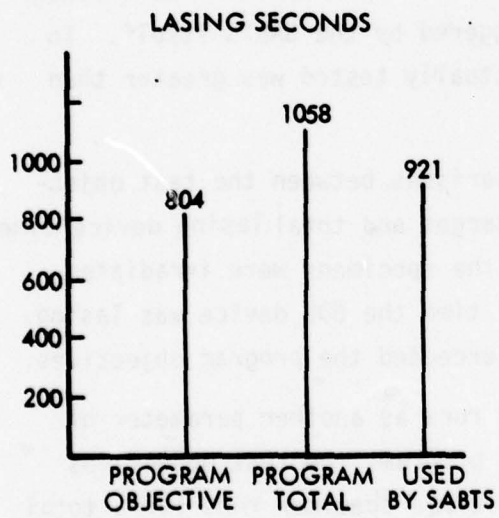

(c)

Figure 30. SABTS Test Summary

# LASING RUNS

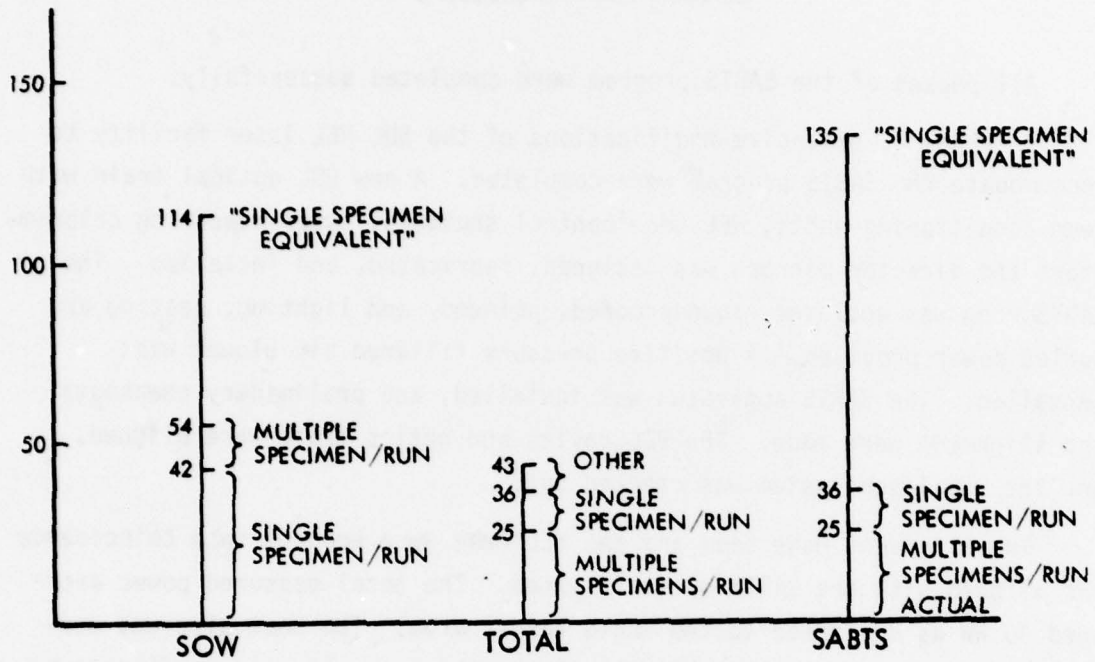

Figure 31. SABTS Lasing Runs Summary

planned. An additional seven runs were made during the test series which dealt with alignment and checkout and included several aborted runs.

Section VI  
SUMMARY AND CONCLUSIONS

All phases of the SABTS program were completed successfully.

In Phase I, extensive modifications of the BDL HEL laser facility to accommodate the SABTS program were completed. A new BDL optical train with beam conditioning ducts, HEL beam control shutters, power measuring calorimeters and director mirrors was designed, fabricated, and installed. The SABTS room was enclosed, soundproofed, painted, and lighting, heating and outlet power provided. A positive pressure filtered air blower was installed. The SABTS apparatus was installed, and preliminary checkouts and alignment were made. The BDL cavity and optics train were aligned, and the BDL laser system was checked out.

The alignment HeNe beam and the HEL beam were brought into coincidence and aligned with the SABTS optical system. The total measured power averaged 40 kW as delivered to the SABTS target area. The beam size was measured in three different ways. All showed the beam size and profile to be within the test requirements.

The objectives of Phases II and III were also met successfully. The SABTS acceptance tests were completed, and all specifications which were verified in Phase I were maintained. From a test support point-of-view, all test goals were met or exceeded. For example, a total of 135 test specimens were irradiated by the beam. Only 114 samples had been planned. A total of 357 seconds of available time-on-target were delivered, compared to an estimated 294. Total lasing time for the program was 1058 seconds which can be compared to the 804 seconds estimated at the beginning of the program. In addition, an Add-On Effects Test was successfully integrated and operated for the duration of the Phase III test series.

The following recommendations are made for future tests:

A modification of the experiment to accommodate more specimens per run would allow longer run times and the same data to be obtained in fewer runs with substantial savings. Once a run is started, the additional

effort for a 120 second run versus a 5 second run is relatively insignificant.

In addition, redundancy in data instrumentation can serve to improve successful data collection. Duplication of equipment, and design of parallel data acquisition systems can reduce effects of equipment malfunction and operator error.

Detailed test plans with integrated design, procedures and check lists could also be utilized to good effect. These items serve to develop the most efficient path through a testing matrix and to optimize test activities relative to the program's schedule.

## APPENDIX

This appendix contains three data sheets for each of the 43 tests in the SABTS series (BDL tests VL1-245 through VL1-287). These data sheets are: (1) Estimated Power versus Time, (2) Planned Time Lines and Quick Look Data Sheet, and (3) Beam Intensity Profile. The first sheet is a plot of device power (kW) versus run time (sec). For the first two tests total device power is determined by summing the power measured at the slow shutter calorimeter and that measured at the fang clipper. The calorimeter at the fang clipper was removed (and placed at the SABTS clipper) in favor of an uninstrumented power dump after the second test. Total power from the third test (VL1-247) to the end of the series was calculated from the power measured at the slow shutter calorimeter using a factor developed from the first two tests. The second sheet, Planned Time Lines ..., indicates the planned and actual sequencing during the tests as well as providing specimen information and exposure times. The Beam Intensity Profile (photos) is that seen by the IR (AGA) camera located at the second turning flat mirror (just upstream of the slow shutter).

LASER PERFORMANCE ANALYSIS - RUN NUMBER VL 1-245

**ESTIMATED POWER VS. TIME**

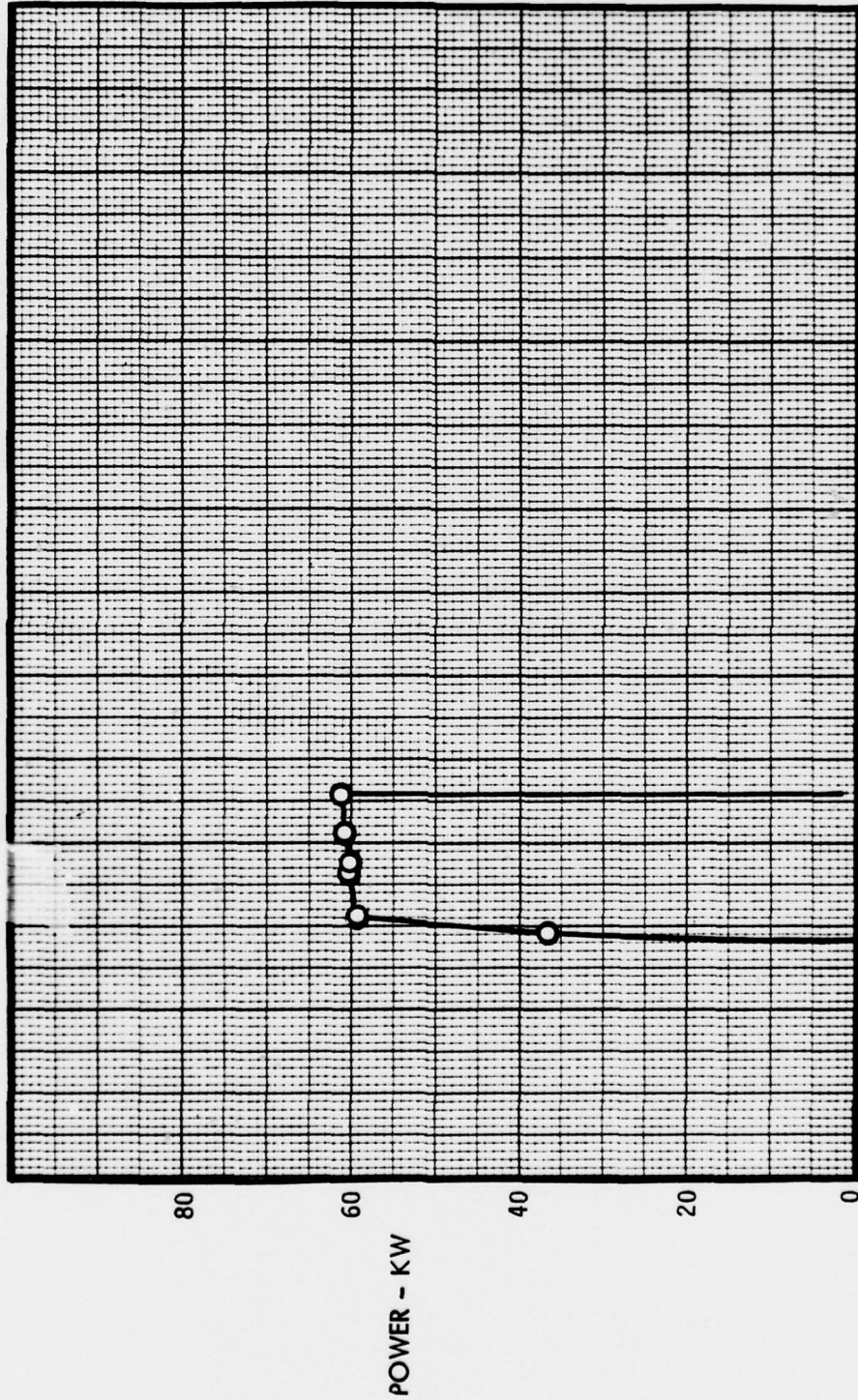

REMARKS: 0.7 SEC PLEXIGLASS BURN (AT ENTRANCE TO SABTS)

TEST AREA @ APPROX 18.6 SECONDS.

PREPARED BY:

*L. Santos*

1-16-77

**PLANNED TIME LINES AND QUICK LOOK DATA SHEET**

QUICK LOOK TEST DATA

TEST NO.	TEST PLAN	DATE	TIME
YLL-245	SALTS	1-1-77	2319
O2 CYL VALVE OPEN (SEC)	O2 CYL VALVE CLOSED (SEC)	LASTING DURATION (SEC)	TOTAL COMPLETED TEST POSITIONS
11	22.7	9.7	1
			PLANNED TOTAL TMR. 67

PLANNED TEST NO. R-1 TIME LINES AS OF DATE 1-7-77 REVISION 0019

TEST SITE T. ROSZMART W. BALL	PLANNED UPPER MAGNIFICATION	CONFIGURATION
	PLANNED LOWER MAGNIFICATION	<input type="checkbox"/> REFLECTIVE <input type="checkbox"/> TRANSMISSIVE

TEST POSITION	SPEECH	COATING DESIGN	PLANNED			ACTUAL			COMMENTS
			EXPOSURE TIME (SEC)	TRANSIT TIME (POST EXPOSURE)	TIME FROM F <sub>2</sub>	TIME SLICE	EST. PWR. AT TARGET	TOTAL POWER	
1	PLEX		0.7		18.6	11.1	44.8	61.0	Essential 1" ZONE
2									
3									
4									
5									
6									

ITEM	START (SEC)	STOP (SEC)	ITEM	START (SEC)	STOP (SEC)
TV CAMERA No. 1	0.1		O-GRAPH	N/A	
No. 2	2.1		SANGAMO No. 1	+6	+20
No. 3			SANGAMO No. 2	N/A	
No. 4			SALTS SEC.	N/A	
SALTS TEST			CALCRIMETER (FANG)	+14	+22.9
			CALCRIMETER (SLOW SHUTTER)	+14	+18
			" "	+19.7	+22.9

**BEAM INTENSITY PROFILE**

AS SEEN BY IR CAMERA VIEWING SECOND TURN FLAT

TOTAL INTENSITY

APPROX. TIME (SEC) +16

LINEAR PROFILE\*

APPROX. TIME (SEC) +16

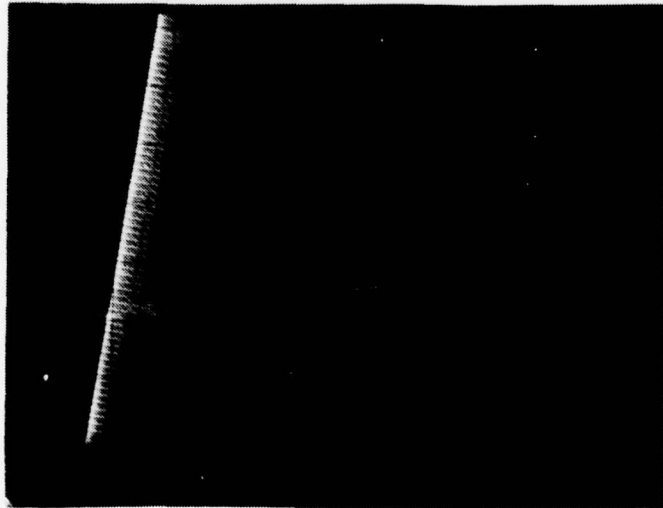
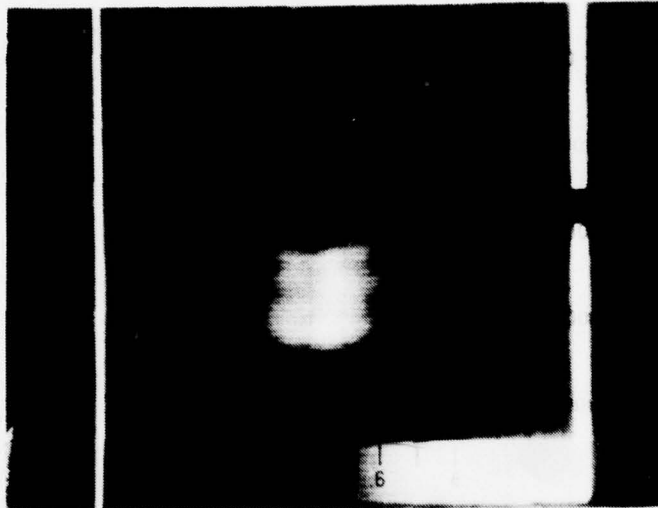

\*PROFILE ALONG SINGLE LINE SCAN SEEN IN TOTAL INTENSITY PICTURE.

LFF BERGERSON

BEAM DIAGNOSTICS ENGINEER

LASER PERFORMANCE ANALYSIS - RUN NUMBER VL 1-246

**ESTIMATED POWER VS. TIME**

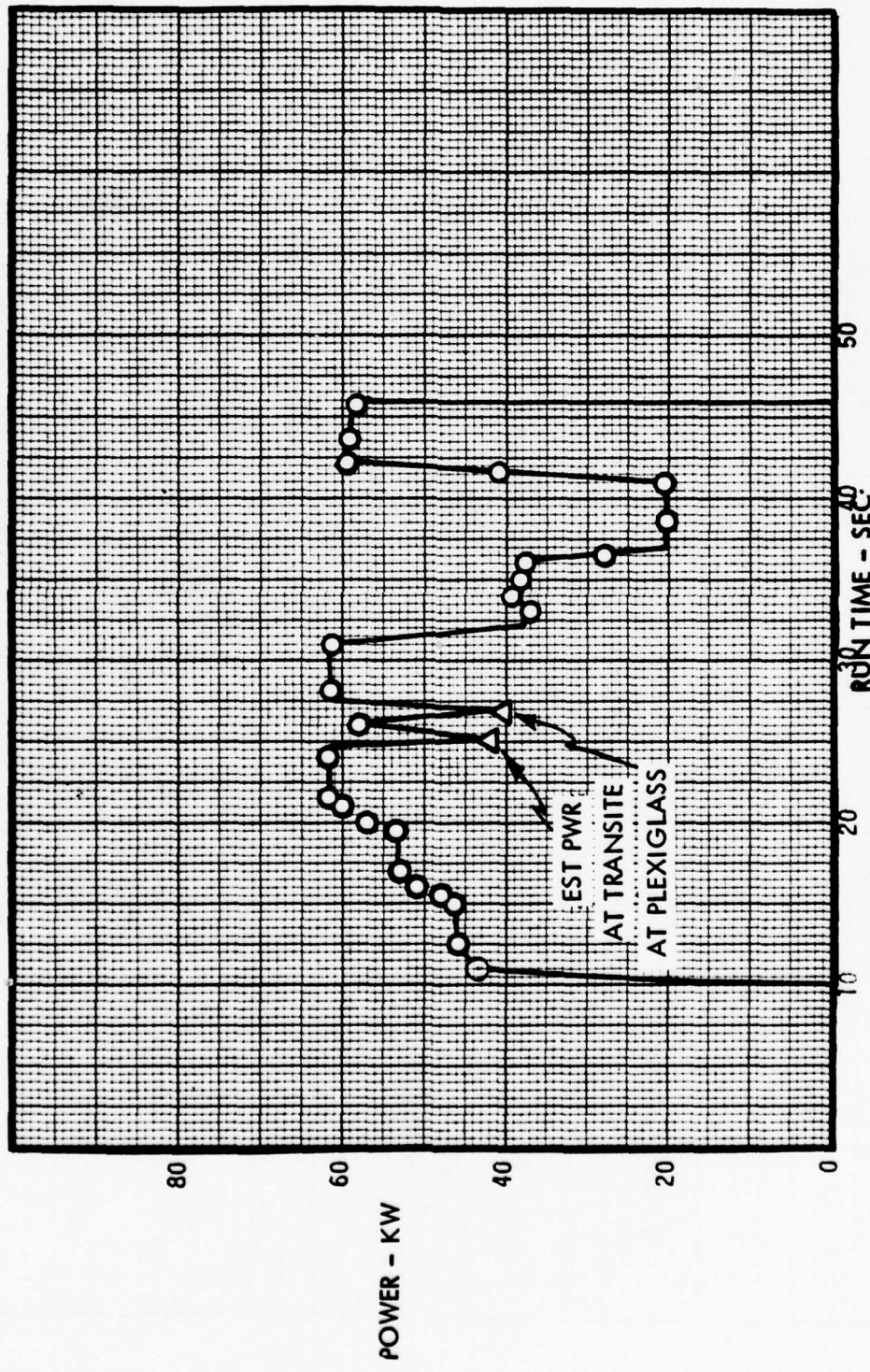

REMARKS: F<sub>2</sub> SCAN WITH TRANSITE & PLEXIGLASS BURNS IN THE

SABTS TEST AREA.

PREPARED BY:

*L. SAKS*  
1-12-77

# PLANNED TIME LINES AND QUICK LOOK DATA SHEET

QUICK LOOK TEST DATA			
RUN NO.	TEST PLAN	DATE	TIME
VLI-246	SABTS	1-11-77	2100
D2 FIRE VALVE OPEN (SEC)	D2 FIRE VALVE CLOSED (SEC)	LASING DURATION (SEC)	TOTAL COMPLETED TEST POSITIONS
10	45.8	35.8	2
PLANNED TEST NO. R-2		AS OF	DATE 1/1-77
TIME LINES		REVISION C	

EXPERIMENTER	PLANNED LINEAR MAGNIFICATION	PLANNED FLAK PER DENSITY	CONFIGURATION	ACTUAL															
				REFLECTIVE	TRANSMISSIVE	TEST POSITION	SPECIMEN NO.	COATING DESIGN	EXPOSURE TIME (SEC)	TRANSIT TIME (POST EXPOSURE)	TIME FROM F <sub>2</sub>	TIME SLICE	EST. PWR. AT TARGET	TOTAL POWER	ACTUAL SPOT DIAMETER	COMMENTS			
T. ROSZHART W. BARR			DVA ZVA	<input type="checkbox"/>	<input type="checkbox"/>														
				1	PLEXI		1.0		26.0	23.7	45.5	61.8							
				2	TRANS		0.7		27.4	22.9	42.5	61.7							
				3															
				4															
				5															
6																			

ITEM	START (SEC)	STOP (SEC)	ITEM	START (SEC)	STOP (SEC)
TV CAMERA No. 1	ON		O-GRAPH	N/A	48.0
No. 2	ON		SANGAMO No. 1	6.0	
No. 3			SANGAMO No. 2	N/A	
No. 4			SABTS SEQ.	N/A	
SABTS INST.	N/A		CALORIMETER (FANG)	10.0	46.0
			CALORIMETER (SLOW SHUTTER)	10.0	26.0
			"	27.4	46.0

LASER PERFORMANCE ANALYSIS, RUN VL1-246

**BEAM INTENSITY PROFILE**

AS SEEN BY IR CAMERA VIEWING SECOND TURN FLAT

TOTAL INTENSITY

APPROX. TIME (SEC) + 20

LINEAR PROFILE\*

APPROX. TIME (SEC) + 20

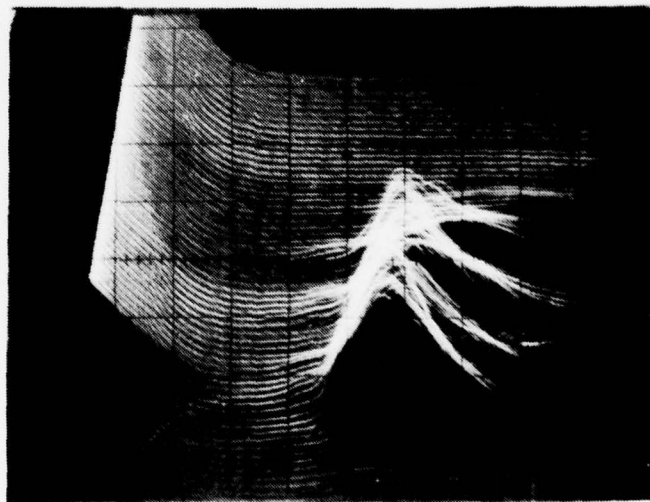
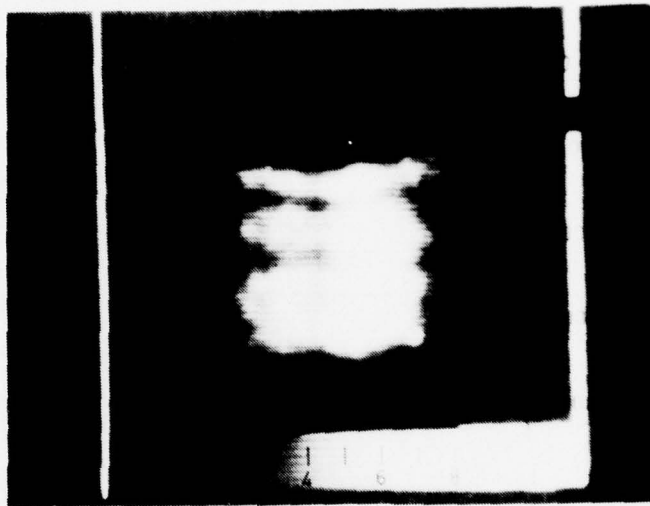

\*PROFILE ALONG SINGLE LINE SCAN SEEN IN TOTAL INTENSITY PICTURE.

LEE BERGERSON  
BEAM DIAGNOSTICS ENGINEER

**ESTIMATED POWER VS. TIME**

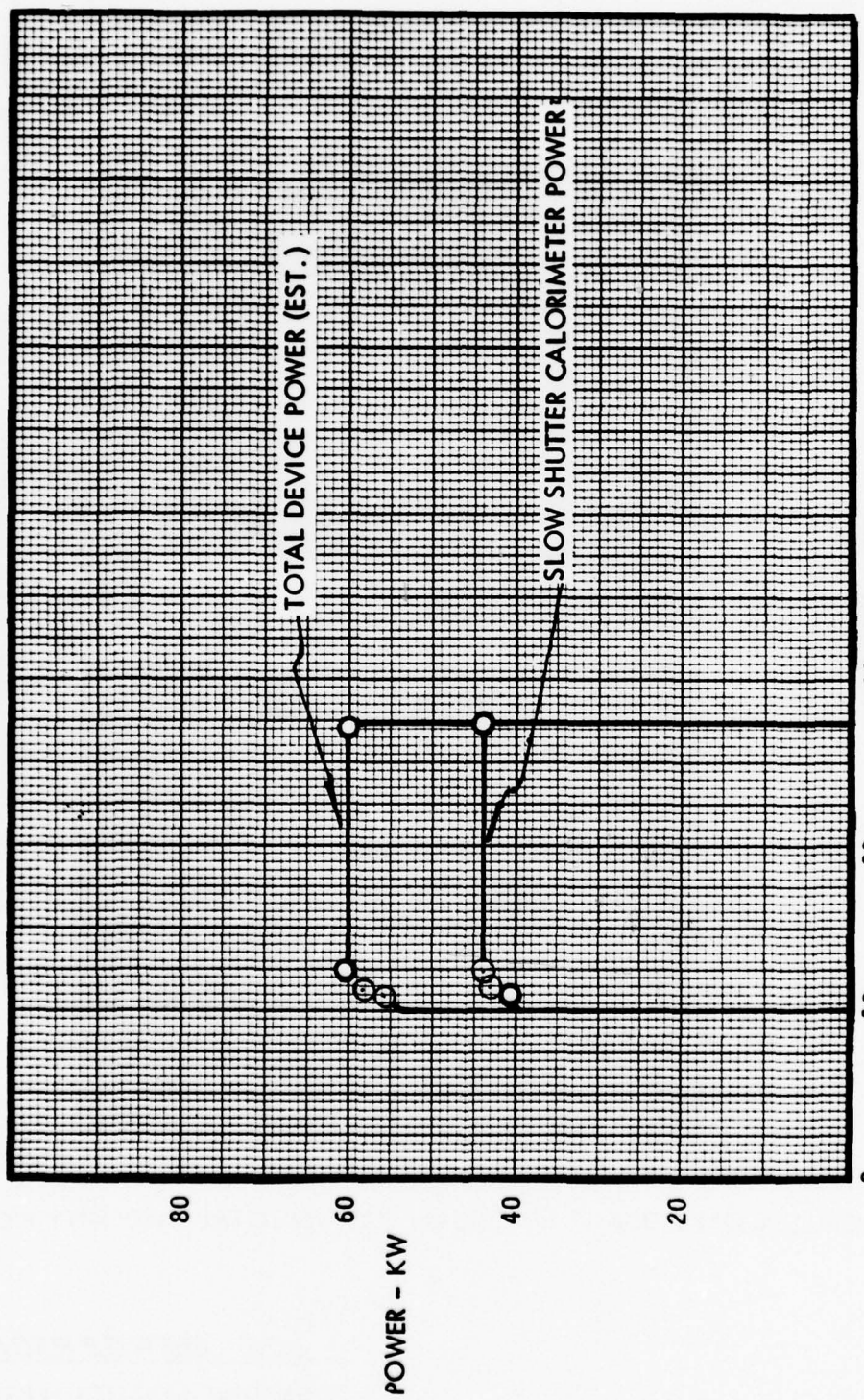

REMARKS: BEAM DIRECTED TO SLOW SHUTTER CALORIMETER FOR ENTIRE TEST (SLOW SHUTTER DID NOT OPEN).

PREPARED BY: L. Sings  
1-14-77

REV: 1-19-77

**PLANNED TIME LINES AND QUICK LOOK DATA SHEET**

QUICK LOOK TEST DATA			
RUN NO.	TEST PLAN	DATE	TIME
Y11-247	SABTS	1-13-77	2320
D2 FIRE VALVE OPEN (SEC)	D2 FIRE VALVE CLOSED (SEC)	LASING DURATION (SEC)	TOTAL COMPLETED TEST POSITIONS
10.4	27.3	16.9	0
			PLANNED TOTAL PWR. 62

**PLANNED TEST NO. FAT-1 TIME LINES AS OF DATE 1-12-77 REVISION 5R1G**

EXPERIMENTER <b>D. MULLEN</b>	PLANNED LINEAR MAGNIFICATION	CONFIGURATION <input type="checkbox"/> REFLECTIVE <input type="checkbox"/> TRANSMISSIVE
	PLANNED PEAK PWR DENSITY <b>10 KW</b>	

TEST POSITION	SPECIMEN NO.	COATING DESIGN	EXPOSURE TIME (SEC)	TRANSIT TIME (POST EXPOSURE)	TIME FROM F <sub>2</sub>	TIME SLICE	EST. PWR. AT TARGET	TOTAL POWER	ACTUAL SPOT DIAMETER	COMMENTS
1	#1 PLEX		.25	1.10	14.00					
2	#2		.25	1.10	15.35					
3	#3		.25	1.10	16.70					
4	#4		.25	1.10	18.05					
5	#5		.25	1.10	19.40					
6	#1 PLEX		3.00		20.75					
NOTE: SLOW SHUTTER DID NOT OPEN										
						26.3		60.2		

ITEM	START (SEC)	STOP (SEC)	ITEM	START (SEC)	STOP (SEC)
TV CAMERA No. 1	ON		O-GRAPH	MANUAL	MANUAL
No. 2	ON		SANGAMO No. 1	6.0	29.0
No. 3	ON		SANGAMO No. 2	N/A	
No. 4	ON		SABTS SEQ.	14.0	23.75
			CALORIMETER (SABTS)	14.0	23.75
			CALORIMETER (SLOW SHUTTER)	10.0	14.0
SABTS INST.			" "	23.75	26.75
HI FLOW SOLENOID	10.0	26.75	" "		

**BEAM INTENSITY PROFILE**

AS SEEN BY IR CAMERA VIEWING SECOND TURN FLAT

TOTAL INTENSITY  
APPROX. TIME (SEC) 10

LINEAR PROFILE\*  
APPROX. TIME (SEC) 10

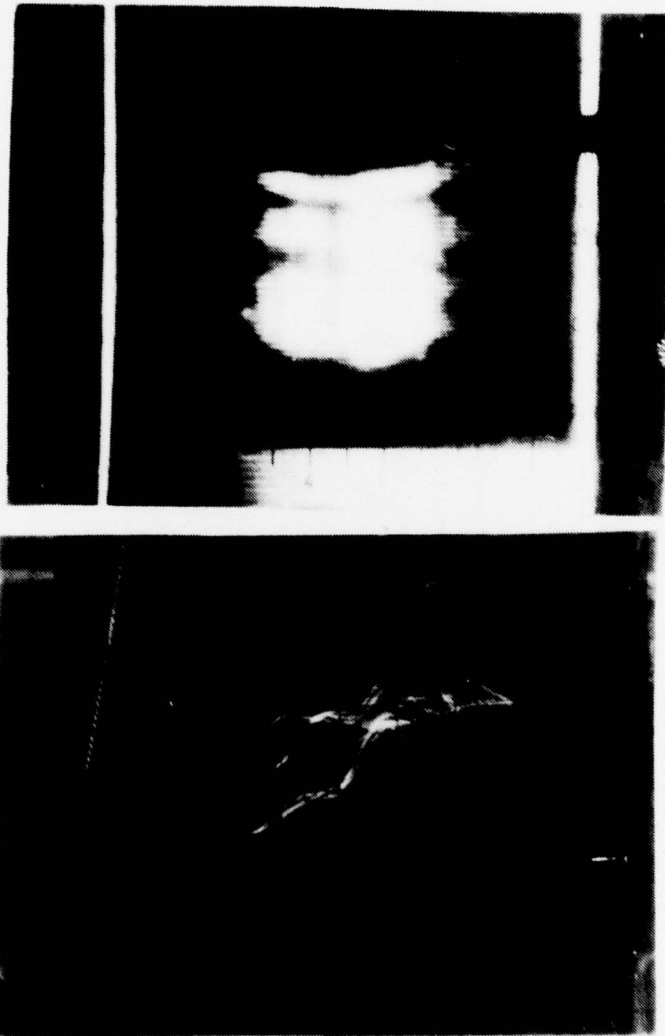

\*PROFILE ALONG SINGLE LINE SCAN SEEN IN TOTAL INTENSITY PICTURE.

LEE BERGERSON  
BEAM DIAGNOSTICS ENGINEER

**PLANNED TIME LINES AND QUICK LOOK DATA SHEET**

RUN NO. <b>VLI-248</b>		TEST PLAN <b>SABTS</b>	DATE <b>1-14-77</b>	TIME <b>1848</b>
D2 FIRE VALVE OPEN (SEC) <b>10.4</b>	D2 FIRE VALVE CLOSED (SEC) <b>27.3</b>	LASING DURATION (SEC) <b>16.9</b>	TOTAL COMPLETED TEST POSITIONS <b>1</b>	PLANNED TOTAL PWR. <b>62</b>

**PLANNED TEST NO. PAT-1 TIME LINES AS OF DATE 1-14-77 REVISION A**

EXPERIMENTER <b>D. MULLEN</b>	PLANNED LINEAR MAGNIFICATION PLANNED PEAK PWR DENSITY <b>10 KW/CM<sup>2</sup></b>	CONFIGURATION <input type="checkbox"/> REFLECTIVE <input type="checkbox"/> TRANSMISSIVE
----------------------------------	--	---

PLANNED		ACTUAL				COMMENTS			
TEST POSITION	SPECIMEN NO.	COATING DESIGN	EXPOSURE TIME (SEC)	TRANSIT TIME (POST EXPOSURE)	TIME FROM F <sub>2</sub>		TIME SLICE	EST. PWR. AT TARGET	TOTAL POWER
1	#1 PLEY		.25	1.10	14.00	12.5	16.5		
2	*		.25	1.10	15.35	NOTE: ALIGNMENT PRISM IN PATH OF BEAM.			
3	*		.25	1.10	16.70				
4	*		.25	1.10	18.05				
5	*		.25	1.10	19.40				
6	#1 PLEY		3.00		20.75				
NOTE: BURN THRU WIRE STOPPED TEST AFTER FIRST TEST POSITION.					23.75				

ITEM	START (SEC)	STOP (SEC)	ITEM	START (SEC)	STOP (SEC)
TV CAMERA No. 1	ON		O-GRAPH	MANUAL	MANUAL
No. 2	ON		SANGAMO No. 1	6.0	29.0
No. 3	ON		SANGAMO No. 2	N/A	
No. 4	DN		SABTS SEC.	14.0	23.75
			CALORIMETER (SABTS)	14.0	23.75
SABTS INST.			CALORIMETER (SLOW SHUTTER)	10.0	14.0
HI FLOW SOLENOID	10.0	27.75	" " "	23.75	27.75

**BEAM INTENSITY PROFILE**

AS SEEN BY IR CAMERA VIEWING SECOND TURN FLAT

TOTAL INTENSITY

APPROX. TIME (SEC) 20.0

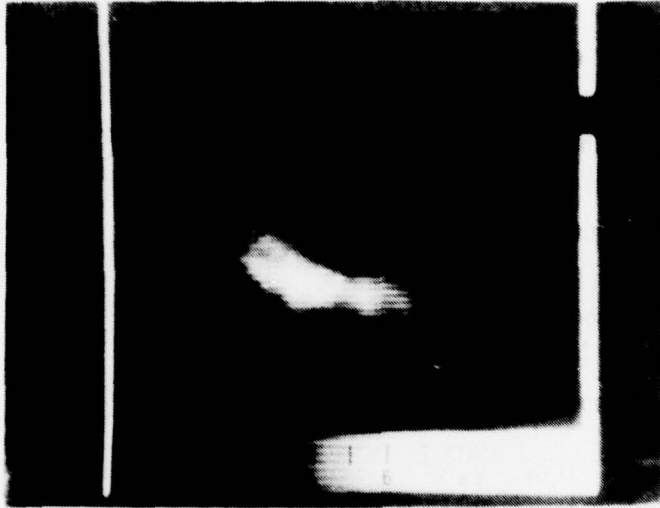

LINEAR PROFILE\*

APPROX. TIME (SEC) 20.0

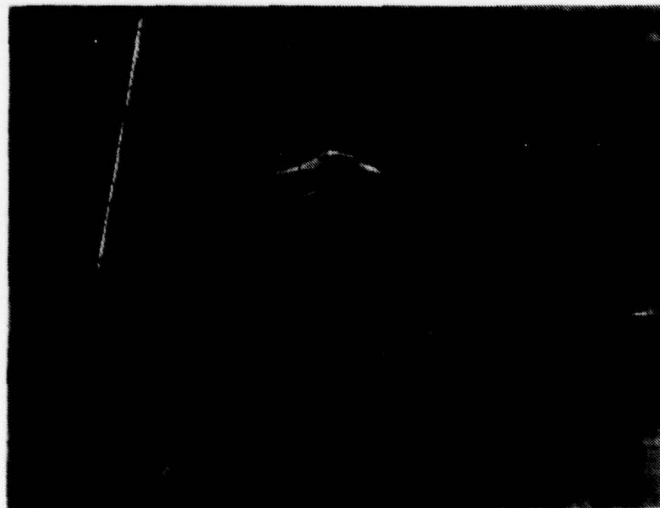

\*PROFILE ALONG SINGLE LINE SCAN SEEN IN TOTAL INTENSITY PICTURE.

LEE BERGERSON

BEAM DIAGNOSTICS ENGINEER

LASER PERFORMANCE ANALYSIS - RUN NUMBER VL 1-249

**ESTIMATED POWER VS. TIME**

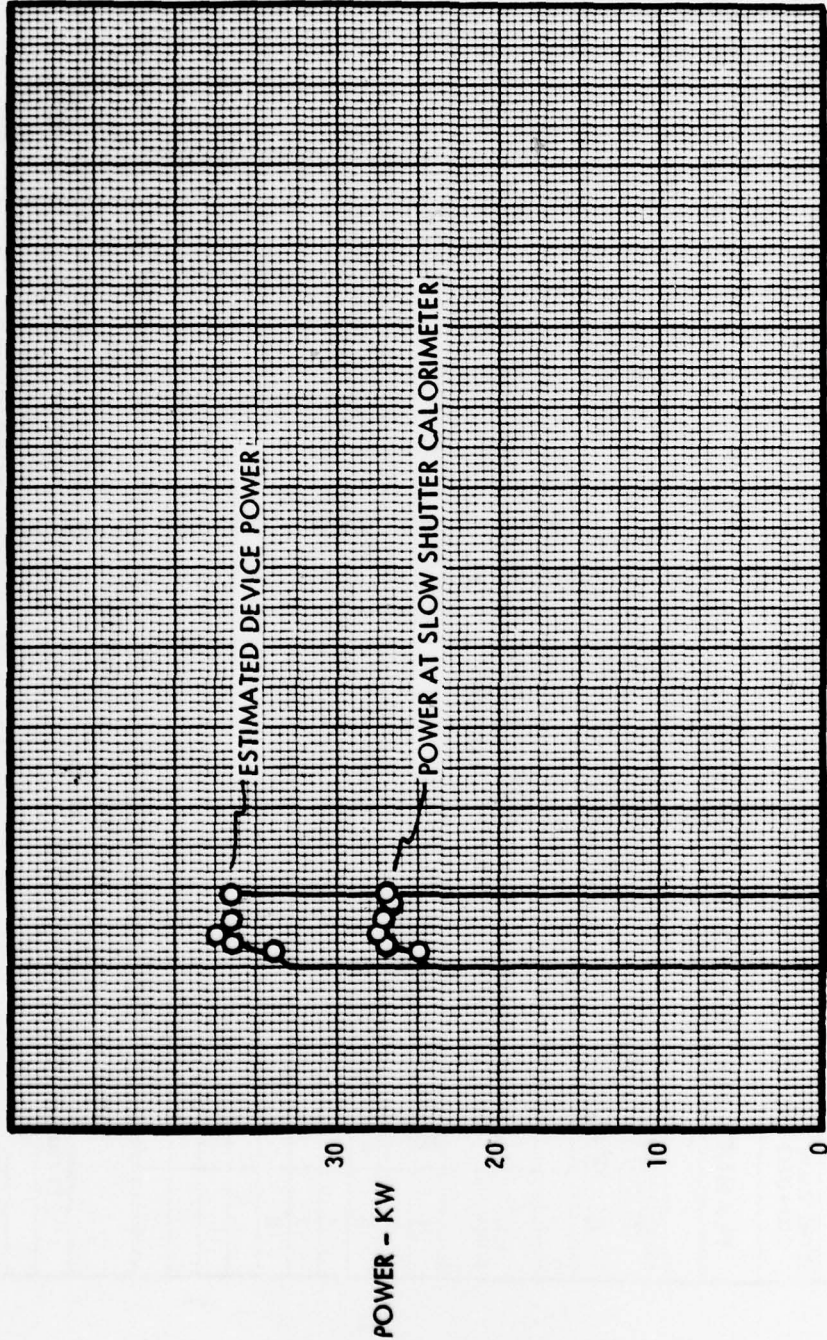

REMARKS: TEST TERMINATED DUE TO LOWER POWER. F2 SCAN &

PLEX BURN NOT COMPLETED

PREPARED BY:

*J. S. NGAS*  
1-19-77

**PLANNED TIME LINES AND QUICK LOOK DATA SHEET**

QUICK LOOK TEST DATA	
RUN NO. <b>VLI-249</b>	TEST PLAN <b>SABTS</b>
DATE <b>1-18-77</b>	TIME <b>1957</b>
D2 FIRE VALVE OPEN (SEC) <b>10.4</b>	D2 FIRE VALVE CLOSED (SEC) <b>14.5</b>
LASING DURATION (SEC) <b>4.1</b>	TOTAL COMPLETED TEST POSITIONS <b>0</b>
	PLANNED TOTAL PWR. <b>67</b>

**PLANNED TEST NO. R-3 TIME LINES AS OF DATE 1-17-77 REVISION A**

EXPERIMENTER <b>I. ROSZHIART</b>	PLANNED LINEAR MAGNIFICATION	CONFIGURATION <input type="checkbox"/> REFLECTIVE <input type="checkbox"/> TRANSMISSIVE
<b>W. BALL</b>	PLANNED PEAK PWR DENSITY	

TEST POSITION	SPECIMEN NO.	COATING DESIGN	PLANNED			ACTUAL			COMMENTS
			EXPOSURE TIME (SEC)	TRANSIT TIME (POST EXPOSURE)	TIME FROM F <sub>2</sub>	TIME SLICE	EST. PWR. AT TARGET	TOTAL POWER	
1	<b>PLEX</b>		<b>0.7</b>		<b>24.0</b>	<b>13.0</b>		<b>27.1</b>	
2									
3	<b>NOTE: LASER WAS SHUT DOWN DURING FIRST STEP OF</b>								
4	<b>F<sub>2</sub> SCAM AS POWER WAS BELOW EXPECTED</b>								
5	<b>LEVEL.</b>								
6									

ITEM	START (SEC)	STOP (SEC)	ITEM	START (SEC)	STOP (SEC)
TV CAMERA No. 1	<b>ON</b>		O-GRAPH	<b>N/A</b>	
No. 2			SANGAMO No. 1	<b>6.0</b>	<b>37.0</b>
No. 3			SANGAMO No. 2	<b>N/A</b>	
No. 4			SABTS SEQ.	<b>N/A</b>	
			CALORIMETER (SABTS)	<b>N/A</b>	
SABTS INST.	<b>N/A</b>		CALORIMETER (SLOW SHUTTER)	<b>10.0</b>	<b>24.0</b>
			" "	<b>24.7</b>	<b>35.0</b>

LASER PERFORMANCE ANALYSIS, RUN VL1-249

**BEAM INTENSITY PROFILE**

AS SEEN BY IR CAMERA VIEWING SECOND TURN FLAT

TOTAL INTENSITY

APPROX. TIME (SEC) 12.0

LINEAR PROFILE\*

APPROX. TIME (SEC) 12.0

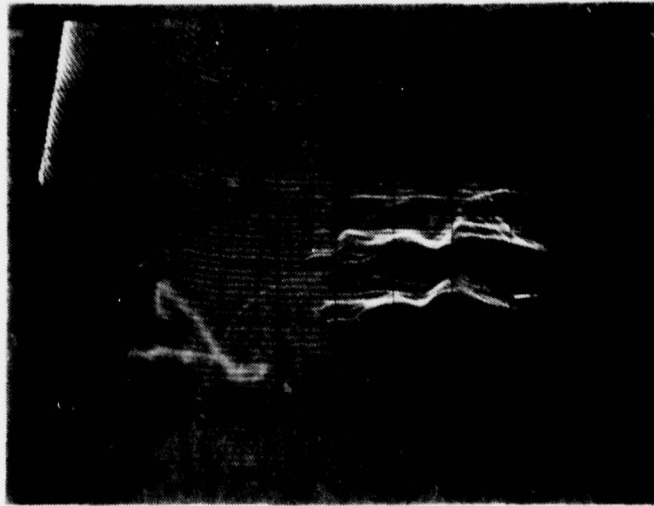
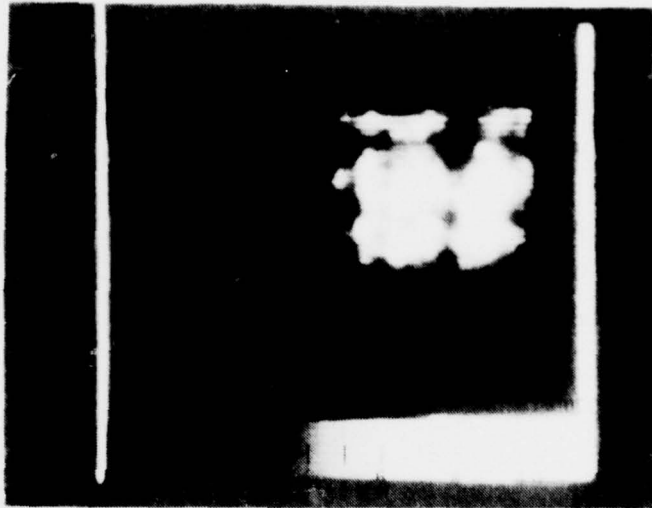

\*PROFILE ALONG SINGLE LINE SCAN SEEN IN TOTAL INTENSITY PICTURE.

LEE BERGERSON

BEAM DIAGNOSTICS ENGINEER

LASER PERFORMANCE ANALYSIS - RUN NUMBER VL 1-250

### ESTIMATED POWER VS. TIME

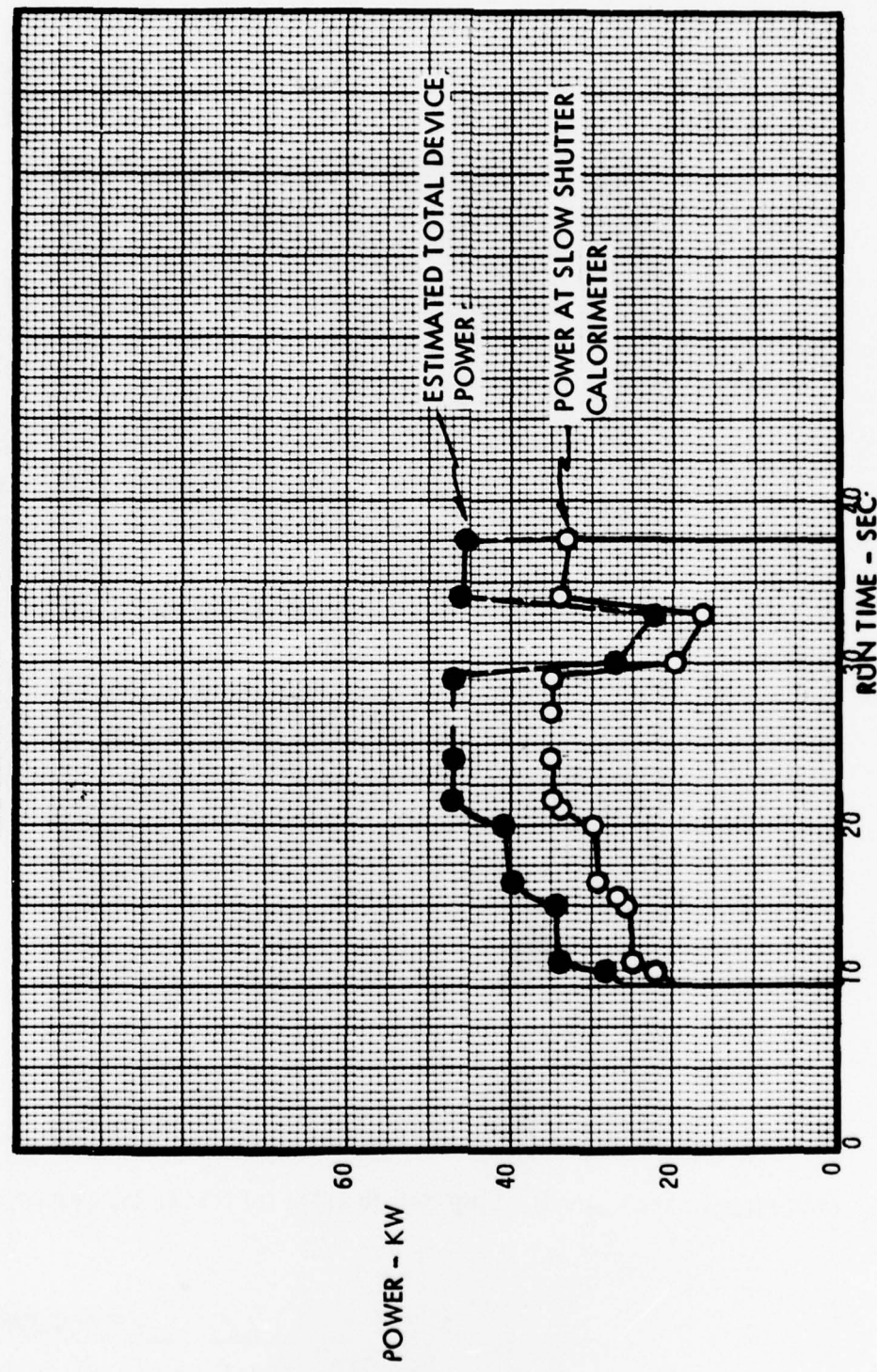

REMARKS: F2 SCAN WITH PLEXIGLASS BURN AT ~ 25 SEC.

PREPARED BY: V. SINGS  
1-19-77

**PLANNED TIME LINES AND QUICK LOOK DATA SHEET**

**QUICK LOOK TEST DATA**

RUN NO. <b>VLI-250</b>	TEST PLAN <b>SABTS</b>	DATE <b>1-18-77</b>	TIME <b>2212</b>
D2 FIRE VALVE OPEN (SEC) <b>10.4</b>	D2 FIRE VALVE CLOSED (SEC) <b>37.6</b>	LASING DURATION (SEC) <b>27.2</b>	TOTAL COMPLETED TEST POSITIONS <b>1</b>
PLANNED TEST NO. <b>R-3</b> TIME LINES			PLANNED TOTAL PWR. <b>67</b>

AS OF DATE **1-17-77** REVISION **A**

EXPERIMENTER <b>T. ROSZHAKT W. BALL</b>	PLANNED LINEAR MAGNIFICATION	CONFIGURATION <input type="checkbox"/> REFLECTIVE <input type="checkbox"/> TRANSMISSIVE
	PLANNED PEAK PWR DENSITY	

PLANNED				ACTUAL				COMMENTS	
TEST POSITION	SPECIMEN NO.	COATING DESIGN	EXPOSURE TIME (SEC)	TRANSIT TIME (POST EXPOSURE)	TIME FROM F <sub>2</sub>	TIME SLICE	EST. PWR. AT TARGET		TOTAL POWER
1	<b>PLEX</b>		<b>0.7</b>		<b>24.0</b>	<b>24.3</b>	<b>35.4</b>		
2									
3									
4									
5									
6									

ITEM	START (SEC)	STOP (SEC)	ITEM	START (SEC)	STOP (SEC)
TV CAMERA No. 1	<b>ON</b>		O-GRAPH	<b>N/A</b>	
No. 2			SANGAMO No. 1	<b>6.0</b>	<b>37.0</b>
No. 3			SANGAMO No. 2	<b>N/A</b>	
No. 4			SABTS SEQ.	<b>N/A</b>	
			CALORIMETER (SABTS)	<b>N/A</b>	
SABTS INST.	<b>N/A</b>		CALORIMETER (SLOW SHUTTER)	<b>10.0</b>	<b>34.0</b>
			" "	<b>24.7</b>	<b>35.0</b>

LASER PERFORMANCE ANALYSIS, RUN VLI-250

**BEAM INTENSITY PROFILE**

AS SEEN BY IR CAMERA VIEWING SECOND TURN FLAT

TOTAL INTENSITY

APPROX. TIME (SEC) 18.0

LINEAR PROFILE\*

APPROX. TIME (SEC) 18.0

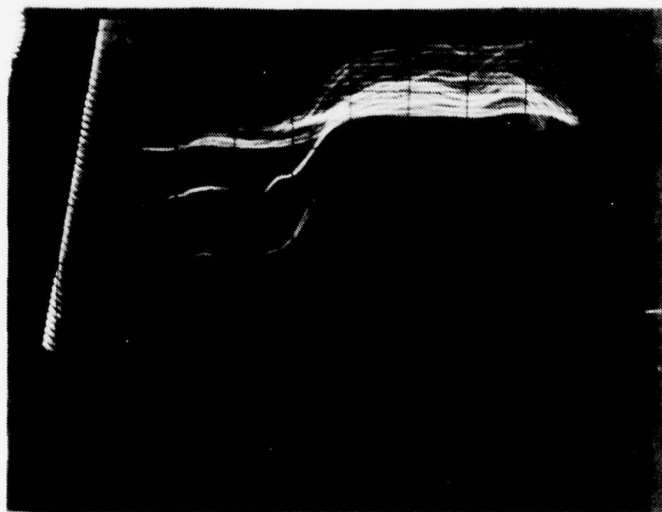
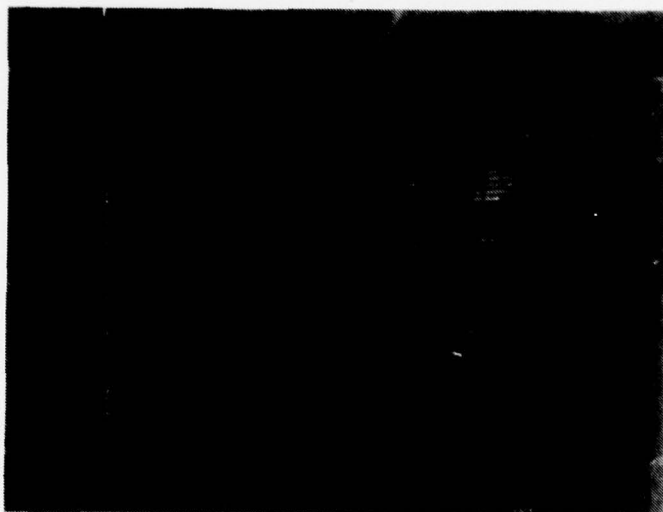

\*PROFILE ALONG SINGLE LINE SCAN SEEN IN TOTAL INTENSITY PICTURE.

LEE BERGERSON

BEAM DIAGNOSTICS ENGINEER

LASER PERFORMANCE ANALYSIS - RUN NUMBER VL 1-251

### ESTIMATED POWER VS. TIME

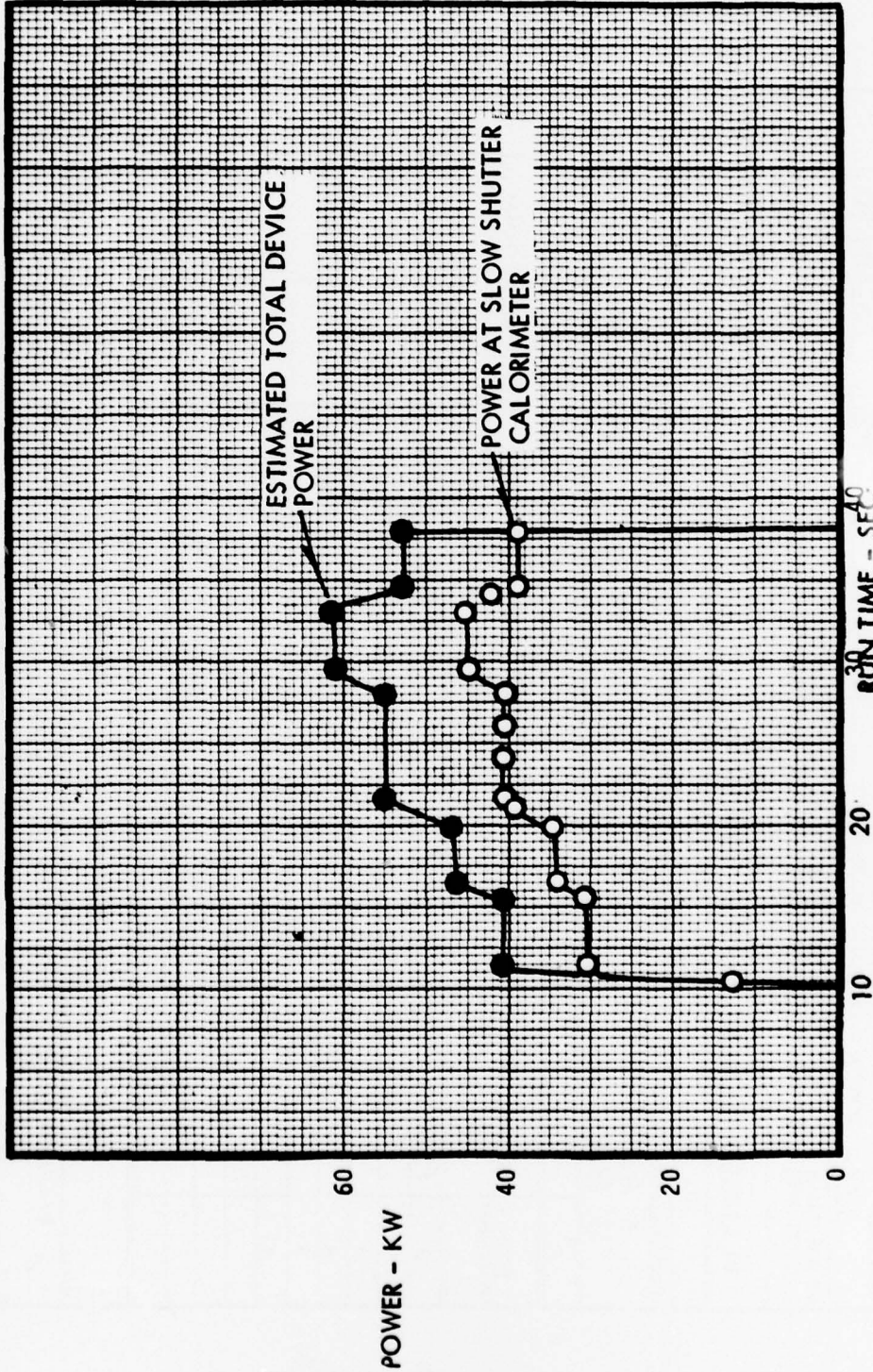

REMARKS: F<sub>2</sub> SCAN WITH PLEXIGLASS BURN @ ~ 25 SECONDS.

PREPARED BY:

*L. Swigs*  
1-20-77

**PLANNED TIME LINES AND QUICK LOOK DATA SHEET**

**QUICK LOOK TEST DATA**

RUN NO.	TEST PLAN	DATE	TIME	PLANNED TOTAL PWR.
VLI-251	SABTS	1-19-77	2315	67
D2 FIRE VALVE OPEN (SEC)	D2 FIRE VALVE CLOSED (SEC)	LASING DURATION (SEC)	TOTAL COMPLETED TEST POSITIONS	
10.4	37.8	27.4	1	

**PLANNED TEST NO. R-4 TIME LINES AS OF DATE 1-17-77 REVISION 0R16**

EXPERIMENTER	PLANNED LINEAR MAGNIFICATION	CONFIGURATION
T. ROSZCHART	PLANNED PEAK PWR DENSITY	<input type="checkbox"/> REFLECTIVE <input type="checkbox"/> TRANSMISSIVE
W. BALL		

TEST POSITION	SPECIMEN NO.	COATING DESIGN	EXPOSURE TIME (SEC)	TRANSIT TIME (POST EXPOSURE)	TIME FROM F <sub>2</sub>	TIME SLICE	EST. PWR. AT TARGET	TOTAL POWER	ACTUAL SPOT DIAMETER	COMMENTS
1	PLEX		0.7		24.0	23.8		41.1		
2										
3										
4						32.7		45.6		
5										
6										

ITEM	START (SEC)	STOP (SEC)	ITEM	START (SEC)	STOP (SEC)
TV CAMERA No. 1	ON		O-GRAPH	N/A	
No. 2			SANGAMO No. 1	6.0	37.0
No. 3			SANGAMO No. 2	N/A	
No. 4			SABTS SEQ.	N/A	
			CALORIMETER (SABTS)	N/A	
SABTS INST.	N/A		CALORIMETER (SLOW SHUTTER)	10.0	24.0
			1' "	24.7	38.0

REF: TCR ML21361 PAGE 3 OF 4

LASER PERFORMANCE ANALYSIS, RUN VL1-251

**BEAM INTENSITY PROFILE**

AS SEEN BY IR CAMERA VIEWING SECOND TURN FLAT

TOTAL INTENSITY

APPROX. TIME (SEC) 20

LINEAR PROFILE\*

APPROX. TIME (SEC) 20

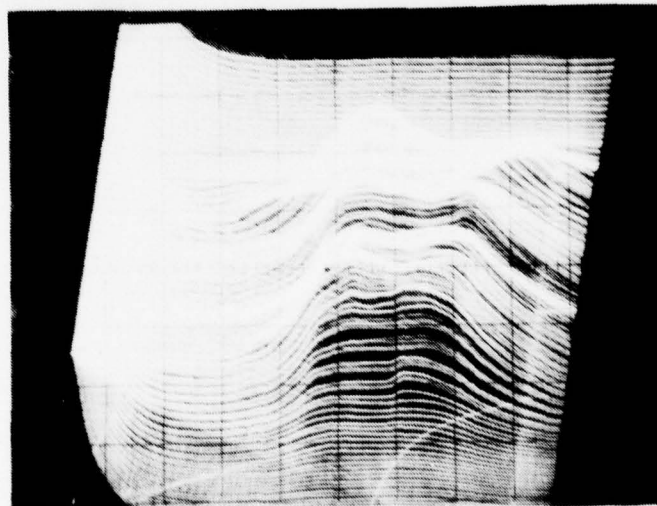
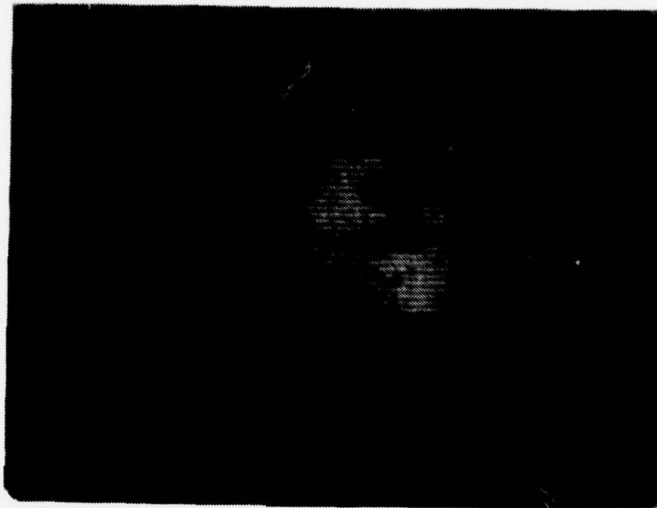

\*PROFILE ALONG SINGLE LINE SCAN SEEN IN TOTAL INTENSITY PICTURE.

LEE BERGERSON

BEAM DIAGNOSTICS ENGINEER

LASER PERFORMANCE ANALYSIS - RUN NUMBER VL1-252

### ESTIMATED POWER VS. TIME

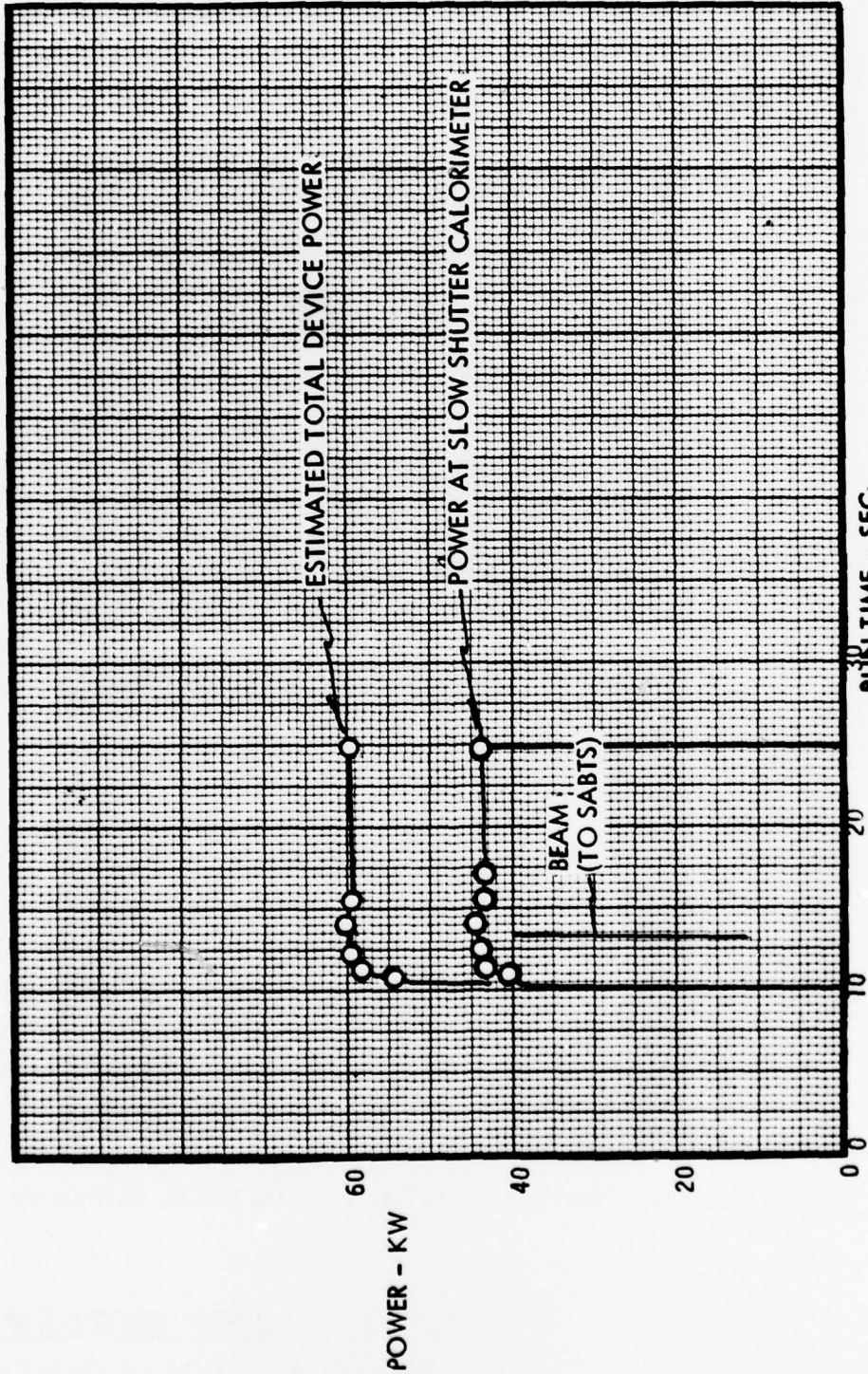

REMARKS: SABTS EXPERIMENT TERMINATED AFTER 1st BURN.

PREPARED BY: L. Seales  
1-21-77

**PLANNED TIME LINES AND QUICK LOOK DATA SHEET**

**QUICK LOOK TEST DATA**

RUN NO. <b>VLI-252</b>	TEST PLAN <b>SABTS</b>	DATE <b>1-21-77</b>	TIME <b>1734</b>
D2 FIRE VALVE OPEN (SEC) <b>10.4</b>	D2 FIRE VALVE CLOSED (SEC) <b>24.8</b>	LASING DURATION (SEC) <b>14.4</b>	TOTAL COMPLETED TEST POSITIONS
			PLANNED TOTAL PWR. <b>59</b>

**PLANNED TEST NO. FAT-2 TIME LINES AS OF DATE 1-19-77 REVISION B**

EXPERIMENTER <b>D. MULLEN</b>	PLANNED LINEAR MAGNIFICATION <b>PLANNED PEAK 40-45 KW/CM<sup>2</sup></b>	CONFIGURATION <input type="checkbox"/> REFLECTIVE <input type="checkbox"/> TRANSMISSIVE
----------------------------------	---	---

PLANNED						ACTUAL				
TEST POSITION	SPECIMEN NO.	COATING DESIGN	EXPOSURE TIME (SEC)	TRANSIT TIME (POST EXPOSURE)	TIME FROM F <sub>2</sub>	TIME SLICE	EST. PWR. AT TARGET	TOTAL POWER	ACTUAL SPOT DIAMETER	COMMENTS
1	* PLEY		.25	1.10	14.00	14.0	44.0			
2	*		.25	1.10	15.35					
3	*		.25	1.10	16.70					
4	*		.25	1.10	18.05					
5	*		.25	1.10	19.40					
6	* PLEY		3.00		20.75					
<b>NOTE: "SPIDER" DETECTOR STOPPED TEST AFTER 1ST SPECIMEN</b>										

ITEM	START (SEC)	STOP (SEC)	ITEM	START (SEC)	STOP (SEC)
TV CAMERA No. 1	ON		O-GRAPH	MANUAL	MANUAL
No. 2	ON		SANGAMO No. 1	6.0	29.0
No. 3	ON		SANGAMO No. 2	N/A	
No. 4	ON		SABTS SEQ.	14.0	23.75
			CALORIMETER (SABTS)	14.0	23.75
SABTS INST.			CALORIMETER (SLOW SHUTTER)	10.0	14.0
HI FLOW SOLENOID	10.0	27.75	" " "	23.75	27.75

LASER PERFORMANCE ANALYSIS, RUN VL1-252

**BEAM INTENSITY PROFILE**

AS SEEN BY IR CAMERA VIEWING SECOND TURN FLAT

TOTAL INTENSITY  
APPROX. TIME (SEC) 20

LINEAR PROFILE\*  
APPROX. TIME (SEC) 20

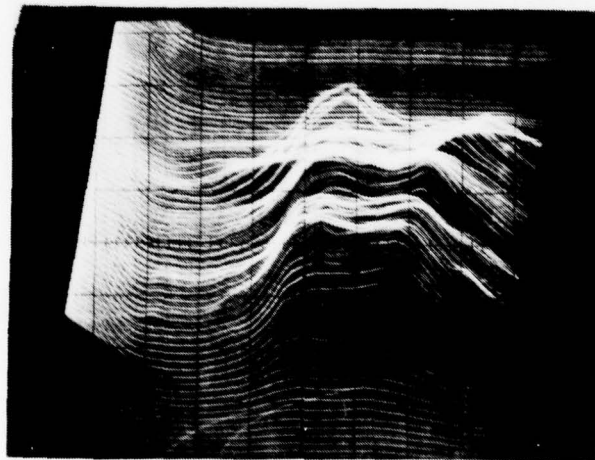
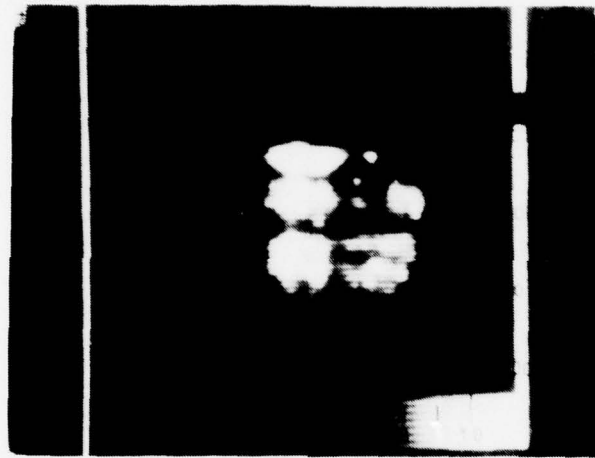

\*PROFILE ALONG SINGLE LINE SCAN SEEN IN TOTAL INTENSITY PICTURE.

LEE BERGERSON  
BEAM DIAGNOSTICS ENGINEER

LASER PERFORMANCE ANALYSIS - RUN NUMBER VL 1-253

### ESTIMATED POWER VS. TIME

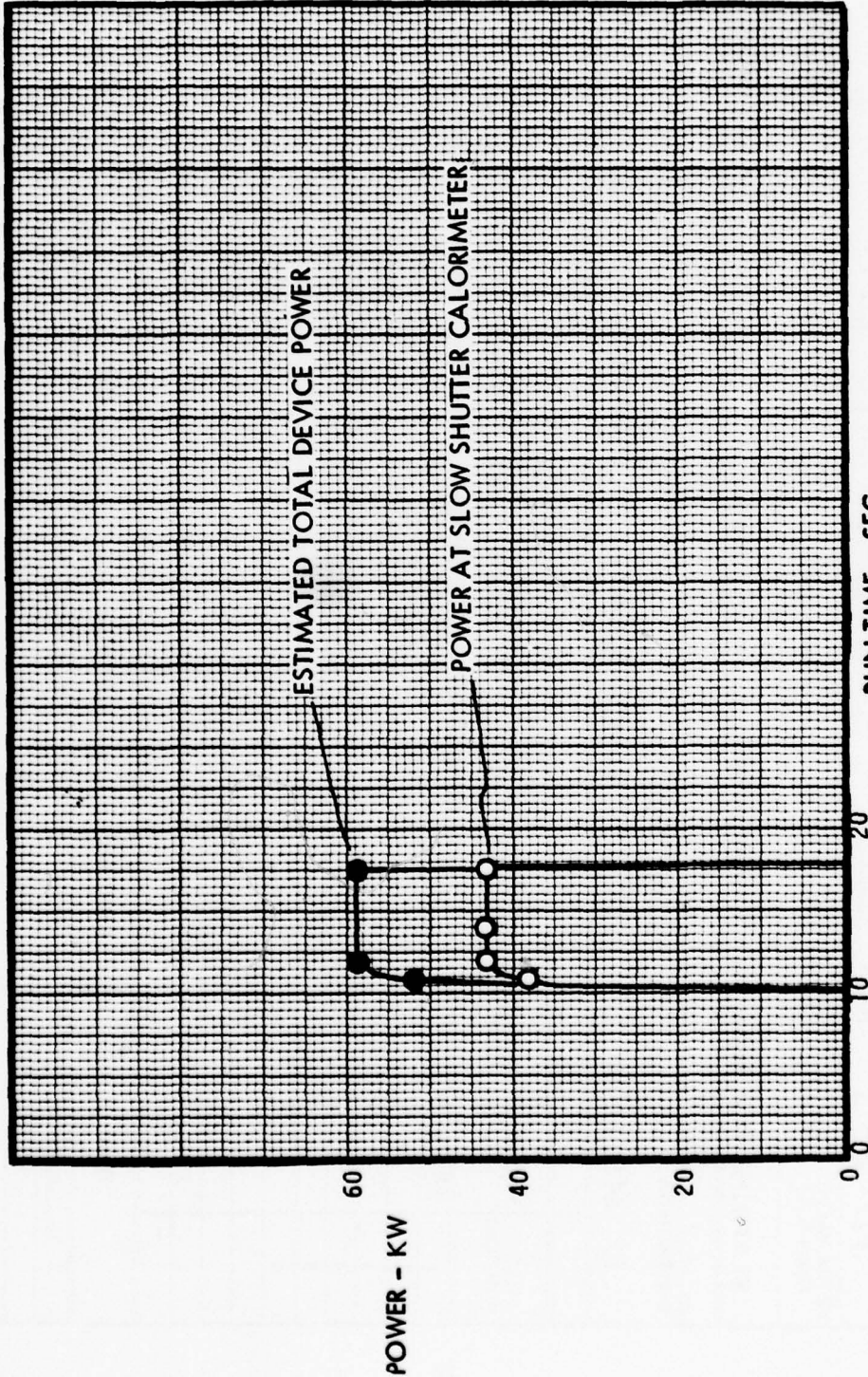

REMARKS: Plexiglass Burn Through SABTS Cart (0.25sec)

@ 14. + Sec.

PREPARED BY:

J. SINGH  
1-22-77

# PLANNED TIME LINES AND QUICK LOOK DATA SHEET

RUN NO.	TEST PLAN	DATE	TIME	PLANNED TOTAL PWR.
VLI-253	SABTS	1-21-77	2211	59
D2 FIRE VALVE OPEN (SEC)	D2 FIRE VALVE CLOSED (SEC)	LASING DURATION (SEC)	TOTAL COMPLETED TEST POSITIONS	
10.4	17.6	7.2	1	

PLANNED TEST NO. **FAT-3** TIME LINES AS OF DATE **1-21-77** REVISION **ORIG**

EXPERIMENTER	PLANNED LINEAR MAGNIFICATION	CONFIGURATION
<b>D. MULLEN</b>	PLANNED PEAK PWR DENSITY <b>40-45 KW/CM<sup>2</sup></b>	<input type="checkbox"/> REFLECTIVE <input type="checkbox"/> TRANSMISSIVE

TEST POSITION	SPECIMEN NO.	COATING DESIGN	PLANNED				ACTUAL				COMMENTS	
			EXPOSURE TIME (SEC)	TRANSIT TIME (POST EXPOSURE)	TIME FROM F <sub>2</sub>	TIME SLICE	EST. PWR. AT TARGET	TOTAL POWER	ACTUAL SPOT DIAMETER			
1	PLEX		.25		14.00	14.0	43.5					PLEX IN FRT OF CONVEX MIRROR
2					14.25							
3												
4												
5												
6												

ITEM	START (SEC)	STOP (SEC)	ITEM	START (SEC)	STOP (SEC)
TV CAMERA No. 1	ON		O-GRAPH	MAN.	MAN.
No. 2	"		SANGAMO No. 1	6.0	20.0
No. 3	"		SANGAMO No. 2	NA	
No. 4	"		SABTS SEQ.	14.0	14.25
			CALORIMETER (SABTS)	14.0	14.25
SABTS INST.			CALORIMETER (SLOW SHUTTER)	10.0	14.00
HI FLOW SOLENOID	10.0	17.75	" "	14.25	17.75

LASER PERFORMANCE ANALYSIS, RUN VLI-253

**BEAM INTENSITY PROFILE**

AS SEEN BY IR CAMERA VIEWING SECOND TURN FLAT

TOTAL INTENSITY

APPROX. TIME (SEC) 14.0

LINEAR PROFILE\*

APPROX. TIME (SEC) 14.0

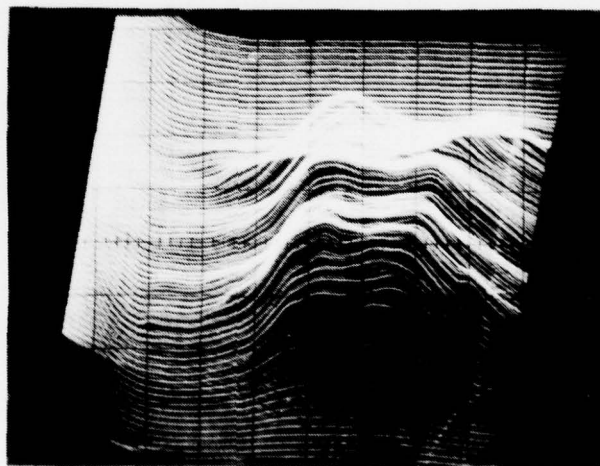

\*PROFILE ALONG SINGLE LINE SCAN SEEN IN TOTAL INTENSITY PICTURE.

LEE BERGERSON

BEAM DIAGNOSTICS ENGINEER

LASER PERFORMANCE ANALYSIS - RUN NUMBER VL 1-254

### ESTIMATED POWER VS. TIME

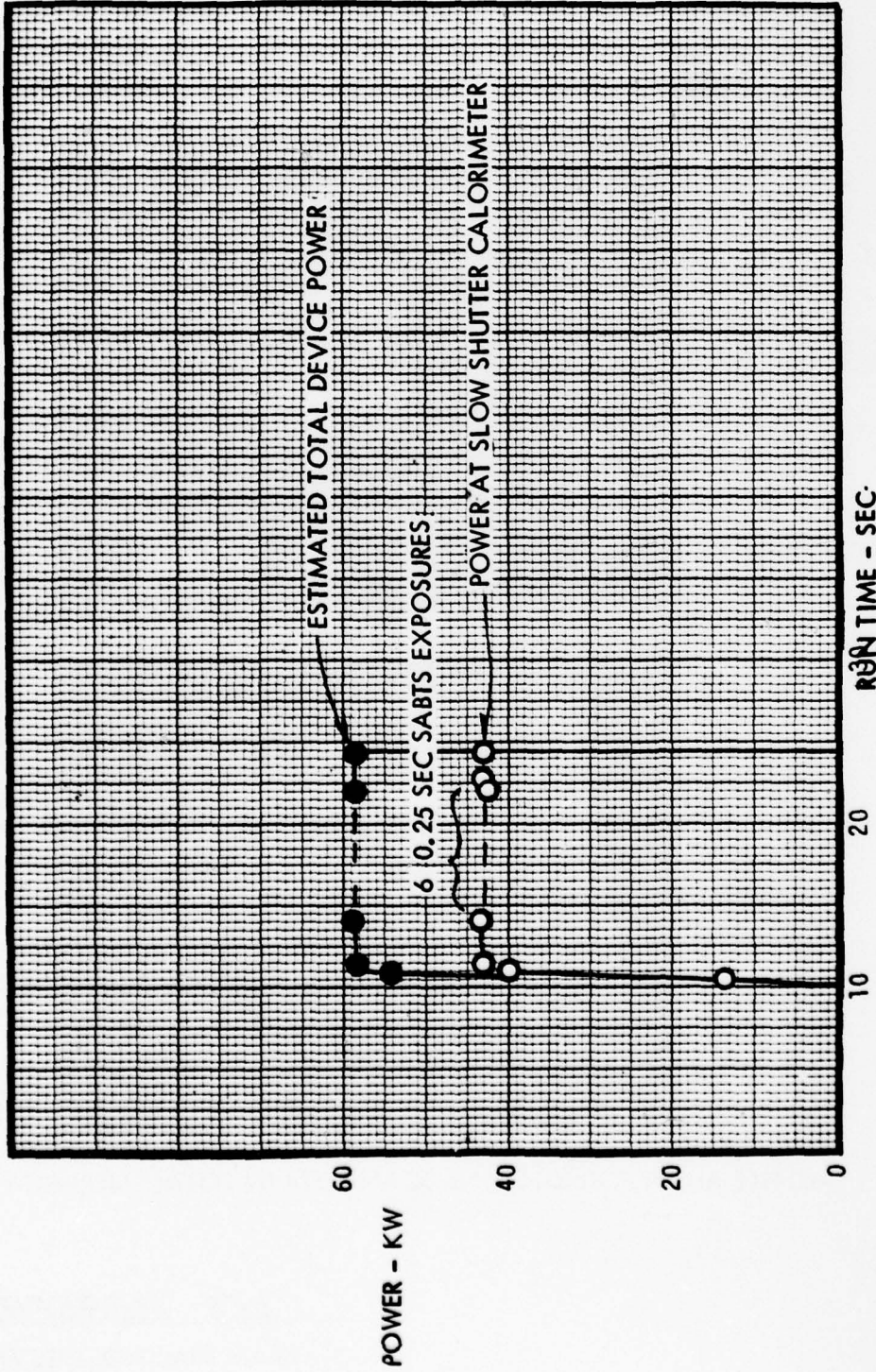

REMARKS:

PREPARED BY:

J. SINGS  
1-24-77

**PLANNED TIME LINES AND QUICK LOOK DATA SHEET**

QUICK LOOK TEST DATA

TEST NO. <b>VLI-254</b>	TEST PLAN <b>SABTS</b>	DATE <b>1-22-77</b>	TIME <b>2159</b>
D2 FIRE VALVE OPEN (SEC) <b>10.4</b>	D2 FIRE VALVE CLOSED (SEC) <b>24.3</b>	LASING DURATION (SEC) <b>13.9</b>	TOTAL COMPLETED TEST POSITIONS <b>6</b>
PLANNED TEST NO. <b>CE-1</b> TIME LINES			DATE <b>1-21-77</b> REVISION <b>A</b>
PLANNED LINEAR MAGNIFICATION <b>1.5</b>		CONFIGURATION <input checked="" type="checkbox"/> REFLECTIVE <input type="checkbox"/> TRANSMISSIVE	
PLANNED PEAK PWR DENSITY <b>8.2 KW/CM<sup>2</sup></b>			

EXPERIMENTER **D MULLEN**

TEST POSITION	SPECIMEN NO.	COATING DESIGN	PLANNED				ACTUAL				COMMENTS
			EXPOSURE TIME (SEC)	TRANSIT TIME (POST EXPOSURE)	TIME FROM F <sub>2</sub>	TIME SLICE	EST. PWR. AT TARGET	TOTAL POWER	ACTUAL SPOT DIAMETER CM		
1	A1	HUGHES 3	.25	1.10	14.00	14.0	29.6	59	2.29		
2	A2	DOF 2	.25	1.10	15.35		27.6				
3	A3	DOF 7	.25	1.10	16.70		26.8				
4	A4	OCLI 4	.25	1.10	18.05		29.2				
5	A5	OCLI 3	.25	1.10	19.40		19.6				
6	A6	PE 5	.25		20.75		28.0		2.29		
					21.00	23.7		59			

ITEM	START (SEC)	STOP (SEC)	ITEM	START (SEC)	STOP (SEC)
TV CAMERA No. 1	ON		O-GRAPH	MAN.	MAN.
No. 2	ON		SANGAMO No. 1	6.0	28.0
No. 3	ON		SANGAMO No. 2	N/A	
No. 4	ON		SABTS SEQ.	14.0	21.0
			CALORIMETER (SABTS)	14.0	21.0
			CALORIMETER (SLOW SHUTTER)	10.0	14.0
HI FLOW SOLENOID	10.0	24.5	" "	21.0	24.5

LASER PERFORMANCE ANALYSIS, RUN VLI-254

**BEAM INTENSITY PROFILE**

AS SEEN BY IR CAMERA VIEWING SECOND TURN FLAT

TOTAL INTENSITY  
APPROX. TIME (SEC) \_\_\_\_\_

LINEAR PROFILE\*  
APPROX. TIME (SEC) \_\_\_\_\_

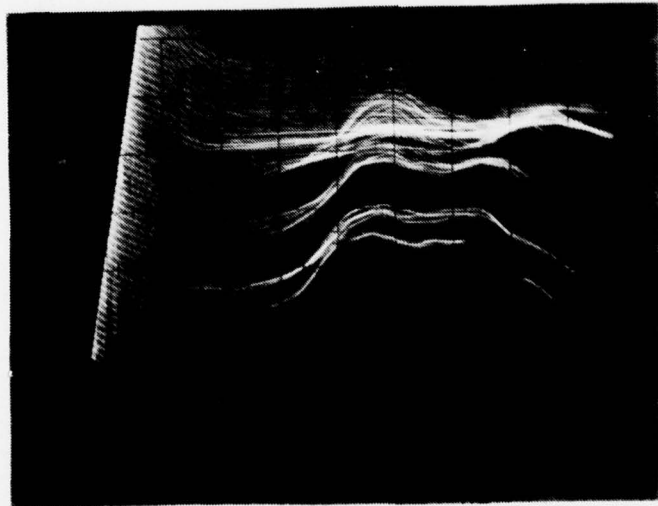
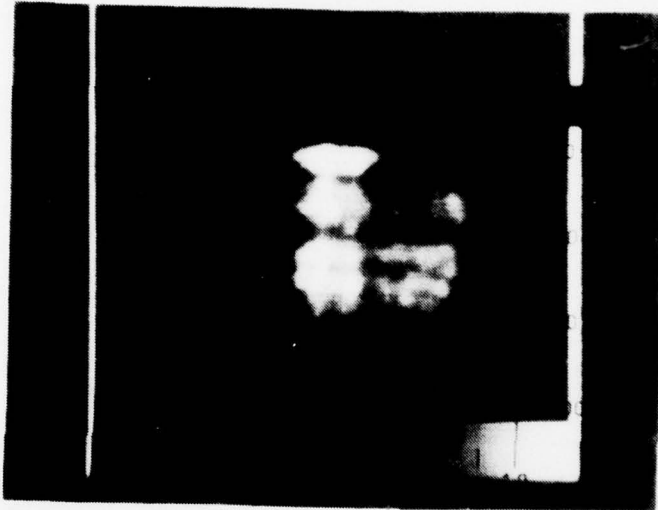

\*PROFILE ALONG SINGLE LINE SCAN SEEN IN TOTAL INTENSITY PICTURE.

LEE BERGERSON  
BEAM DIAGNOSTICS ENGINEER

LASER PERFORMANCE ANALYSIS - RUN NUMBER VL 1-255  
**ESTIMATED POWER VS. TIME**

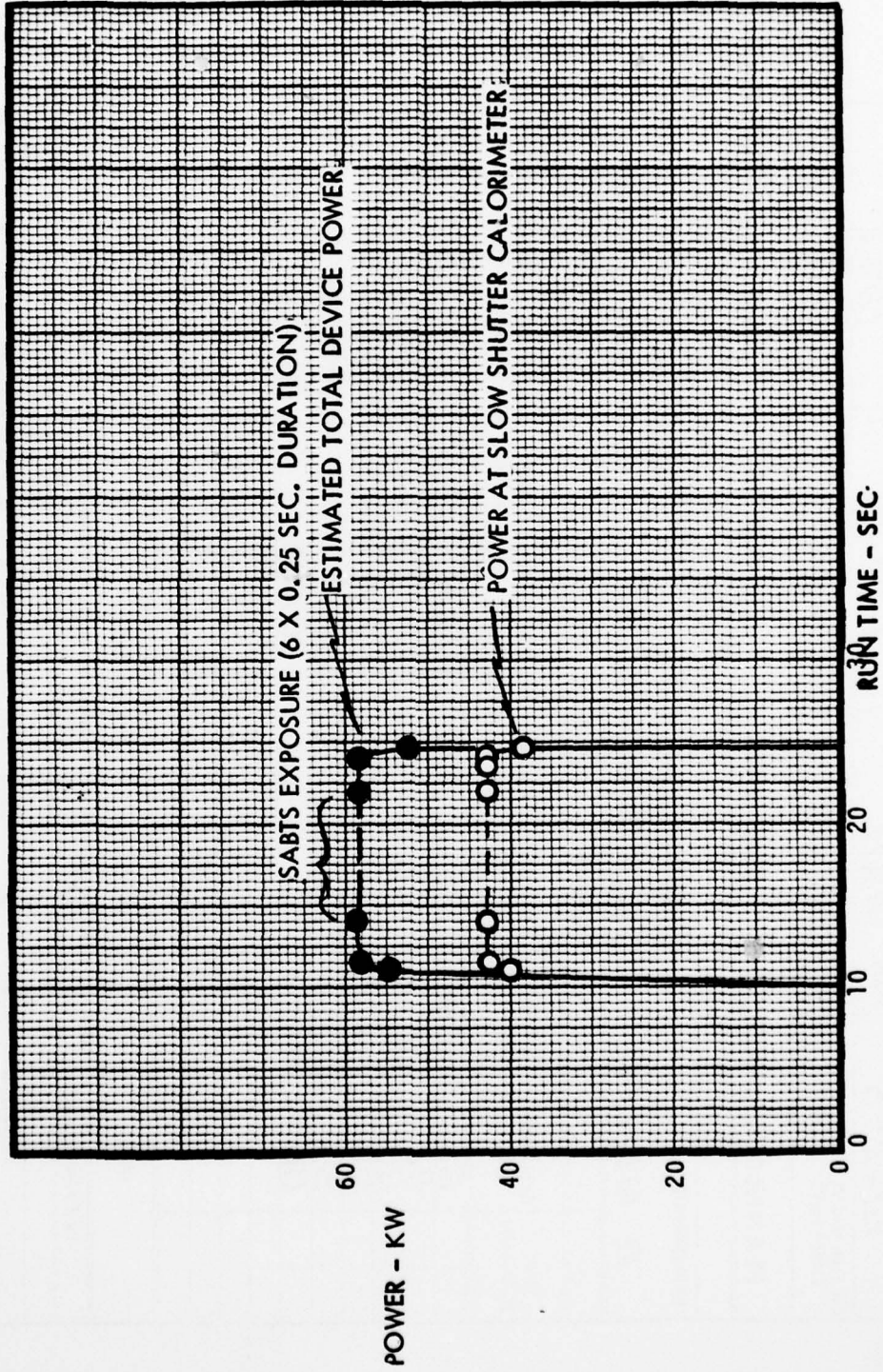

REMARKS: \_\_\_\_\_

PREPARED BY: \_\_\_\_\_

*J. Sings*  
 1-24-77

**PLANNED TIME LINES AND QUICK LOOK DATA SHEET**

QUICK LOOK TEST DATA

RUN NO. <b>VLI-255</b>	TEST PLAN <b>SABTS</b>	DATE <b>1-24-77</b>	TIME <b>1852</b>
D2 FIRE VALVE OPEN (SEC) <b>10.4</b>	D2 FIRE VALVE CLOSED (SEC) <b>24.1</b>	LASING DURATION (SEC) <b>13.7</b>	TOTAL COMPLETED TEST POSITIONS <b>6</b>
PLANNED TEST NO. <b>CE-2</b>			PLANNED TOTAL PWR. <b>59</b>

PLANNED TEST NO. **CE-2** TIME LINES AS OF DATE **1-22-77** REVISION **B**

EXPERIMENTER <b>D. MULLEN</b>	PLANNED LINEAR MAGNIFICATION <b>1.5</b>	CONFIGURATION <input checked="" type="checkbox"/> REFLECTIVE <input type="checkbox"/> TRANSMISSIVE
	PLANNED PEAK PWR DENSITY <b>8.2 KW/CM<sup>2</sup></b>	

TEST POSITION	SPECIMEN NO.	COATING DESIGN	EXPOSURE TIME (SEC)	TRANSIT TIME (POST EXPOSURE)	TIME FROM F <sub>2</sub>	TIME SLICE	EST. PWR. AT TARGET	TOTAL POWER	ACTUAL SPOT DIAMETER CM	COMMENTS
1	B1	HUGHESA	.25	1.10	14.00	14.0	26.2	59	2.29	
2	B2	DOF 3	.25	1.10	15.35		23.2		↑	
3	B3	DOF 6	.25	1.10	16.70		21.8		↓	
4	B4	OCLI 5	.25	1.10	18.05		30.0			
5	B5	OCLI 2	.25	1.10	19.40		18.3			
6	B6	PE B	.25		20.75		20.5		2.29	
					21.00	23.6		59		

ITEM	START (SEC)	STOP (SEC)	ITEM	START (SEC)	STOP (SEC)
TV CAMERA No. 1	ON		O-GRAPH	MAN.	MAN.
No. 2	"		SANGAMO No. 1	6.0	28.0
No. 3	"		SANGAMO No. 2	NA	
No. 4	"		SABTS SEQ.	14.0	21.0
			CALORIMETER (SABTS)	14.0	21.0
SABTS INST.			CALORIMETER (SLOW SHUTTER)	10.0	14.0
HI FLOW SOLENOID	10.0	24.5	" "	21.0	24.5

LASER PERFORMANCE ANALYSIS, RUN VLI-255

**BEAM INTENSITY PROFILE**

AS SEEN BY IR CAMERA VIEWING SECOND TURN FLAT

TOTAL INTENSITY

APPROX. TIME (SEC) \_\_\_\_\_

LINEAR PROFILE\*

APPROX. TIME (SEC) \_\_\_\_\_

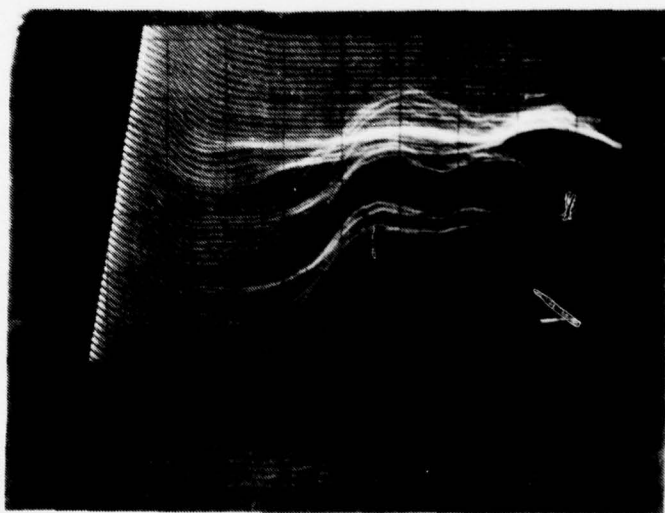
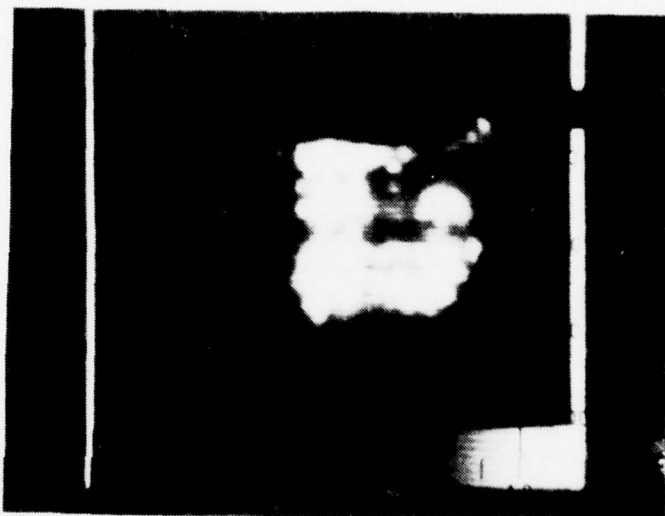

\*PROFILE ALONG SINGLE LINE SCAN SEEN IN TOTAL INTENSITY PICTURE.

LEE BERGERSON

BEAM DIAGNOSTICS ENGINEER

LASER PERFORMANCE ANALYSIS - RUN NUMBER VL 1-256

### ESTIMATED POWER VS. TIME

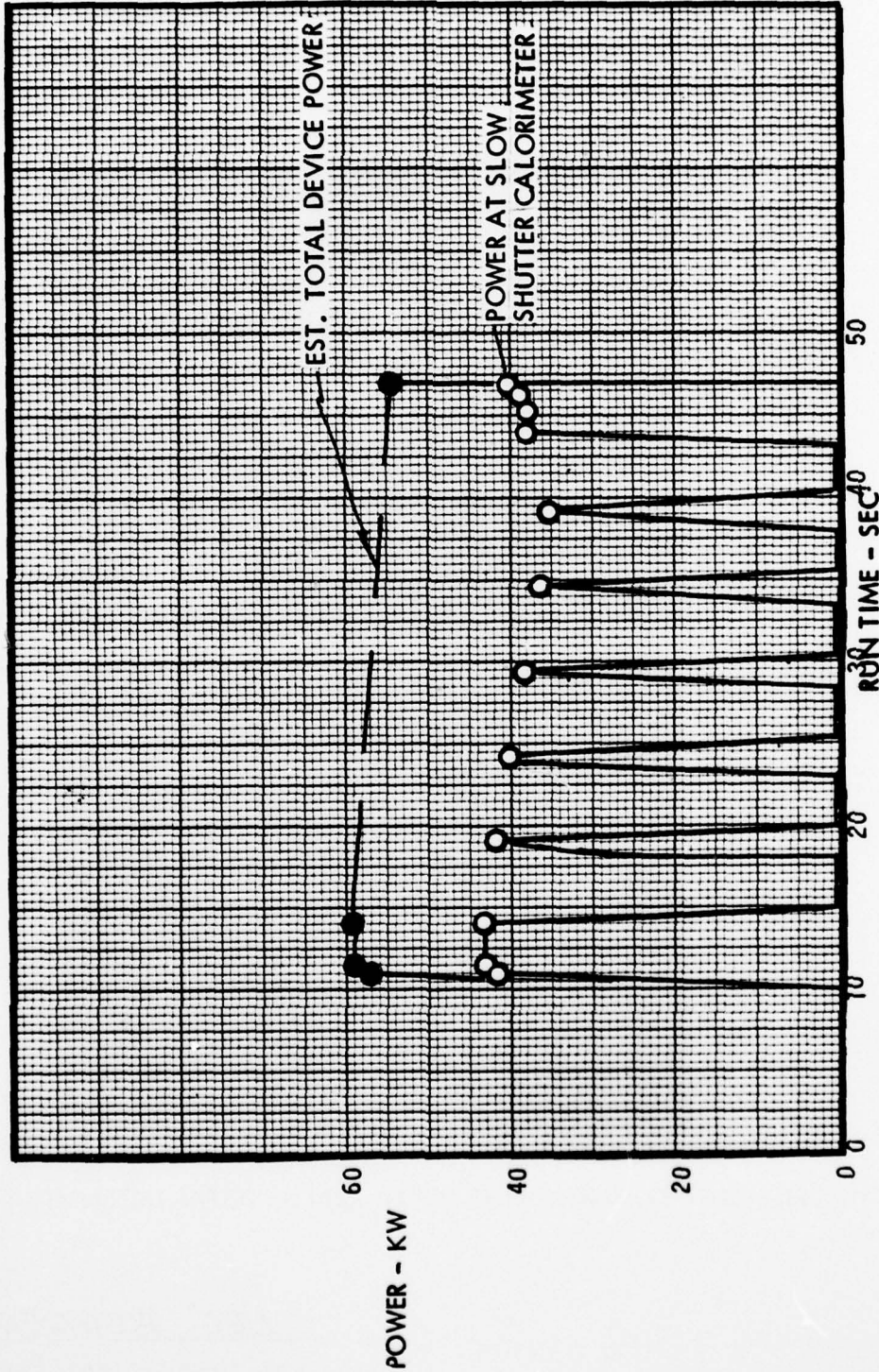

REMARKS:

PREPARED BY:

J. SINGS  
1-25-77

**PLANNED TIME LINES AND QUICK LOOK DATA SHEET**

QUICK LOOK TEST DATA			
RUN NO. <b>VLI-256</b>	TEST PLAN <b>SABTS</b>	DATE <b>1-24-77</b>	TIME <b>2134</b>
D2 FIRE VALVE OPEN (SEC) <b>9.9</b>	D2 FIRE VALVE CLOSED (SEC) <b>46.8</b>	LASING DURATION (SEC) <b>36.9</b>	TOTAL COMPLETED TEST POSITIONS <b>6</b>
			PLANNED TOTAL PWR. <b>59</b>

**PLANNED TEST NO. CE-9 TIME LINES AS OF DATE 1-17-77 REVISION DRIG**

EXPERIMENTER <b>D. MULLEN</b>	PLANNED LINEAR MAGNIFICATION <b>1.5</b>	CONFIGURATION <input checked="" type="checkbox"/> REFLECTIVE <input type="checkbox"/> TRANSMISSIVE
	PLANNED PEAK PWR DENSITY <b>8.2 KW/CM<sup>2</sup></b>	

TEST POSITION	SPECIMEN NO.	COATING DESIGN	PLANNED			ACTUAL			COMMENTS	
			EXPOSURE TIME (SEC)	TRANSIT TIME (POST EXPOSURE)	TIME FROM F <sub>2</sub>	TIME SLICE	EST. PWR. AT TARGET	TOTAL POWER		ACTUAL SPOT DIAMETER
1	C1	HUGHES	4.0	1.10	14.00	17.6	25.8	59	2.29	
2	C2	DOF 1	4.0	1.10	19.10					↑
3	C3	DOF 8	4.0	1.10	24.20	22.7	24.9			↓
4	C4	OCLI 6	4.0	1.10	29.30					
5	C5	OCLI 1	4.0	1.10	34.40					
6	C6	P-E 7	4.0		39.50	38.1	21.8	59	2.29	
					43.50	42.1				
						46.0		54		

ITEM	START (SEC)	STOP (SEC)	ITEM	START (SEC)	STOP (SEC)
TV CAMERA No. 1	ON		O-GRAPH	MAN.	NAN.
No. 2	ON		SANGAMO No. 1	6.0	49.0
No. 3	ON		SANGAMO No. 2	N/A	
No. 4	ON		SABTS SEQ.	14.0	43.5
			CALORIMETER (SABTS)	14.0	43.5
			CALORIMETER (SLOW SHUTTER)	10.0	14.0
SABTS INST. HI FLOW SOLENOID	10.0	47.0	" " "	43.5	47.0

LASER PERFORMANCE ANALYSIS, RUN VL1-256

**BEAM INTENSITY PROFILE**

AS SEEN BY IR CAMERA VIEWING SECOND TURN FLAT

TOTAL INTENSITY  
APPROX. TIME (SEC) 20

LINEAR PROFILE\*  
APPROX. TIME (SEC) 20

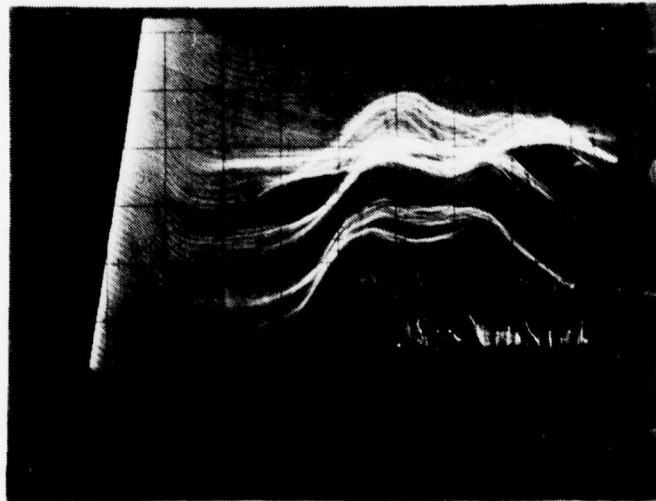
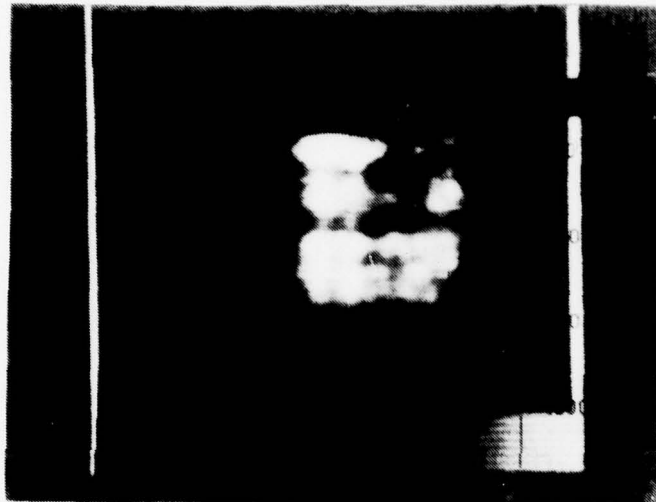

\*PROFILE ALONG SINGLE LINE SCAN SEEN IN TOTAL INTENSITY PICTURE.

LEE BERGERSON

BEAM DIAGNOSTICS ENGINEER

BDL TECHNOLOGY PROGRAM

LASER PERFORMANCE ANALYSIS - RUN NUMBER VL 1-257

SABTS

D<sub>2</sub> FIRE VALVE OPEN (SEC) 10.4

TEST SERIES \_\_\_\_\_

D<sub>2</sub> FIRE VALVE CLOSED (SEC) 24.2

SHOT NUMBER 13

DATE (MO/DAY/YR) 1-26-77

LASING DURATION (SEC) 13.80

PERFORMANCE PARAMETERS AT SELECTED TIME SLICES

SLICE TIME	COMBUSTOR FLOW			CAVITY FLOW		AVERAGE MODULE				SHROUD P <sub>s2d</sub>	SLOW SHUTTER CALORIMETER	Power Ball Calorimeter	
	OXIDIZER	FUEL	DILUENT	FUEL	DIL	COMBUSTOR		NOZZLE					
						F <sub>2</sub> G/SEC	H <sub>2</sub> G/SEC	N <sub>2</sub> G/SEC	He G/SEC				D <sub>2</sub> G/SEC
EF2RC	SEC												
	N/A												
(1) 266.0	13.5	266.8	9.20	-	149.0	121.6	-	11.2	23.3	30.1	6.7	42.6	29.2
(1) 266.0	15.6	267.2	9.17	-	149.1	121.3	-	11.2	24.8	30.4	6.7	-	23.4
(1) 265.0	16.5	266.4	9.20	-	148.9	121.7	-	11.2	25.3	30.6	6.8	-	14.4
(1) 266.5	17.9	267.4	9.19	-	149.2	121.7	-	11.2	25.9	31.3	6.9	-	24.4
(1) *265.5	19.1	268.2	9.20	-	148.8	121.7	-	11.2	26.2	30.8	6.8	-	24.4
(1) 265.0	20.4	266.7	9.19	-	148.8	121.8	-	11.2	26.6	30.9	6.9	-	24.0
(1) 266.3	23.1	268.6	9.22	-	148.9	121.7	-	11.2	27.2	31.1	7.0	47.2	20
													19.8
													σ=3.76

PREPARED BY: J. Sings

1-26-77

NOTES AND DR'S: SLIGHT DIP IN POWER @ END OF TEST (1) 6 0.25 SEC  
HEL EXPOSURES TO SABTS. Tc1P = 71°F \*EF2RC 212 @ one PT 19 + SEC.

LASER PERFORMANCE ANALYSIS - RUN NUMBER VL 1-257

### ESTIMATED POWER VS. TIME

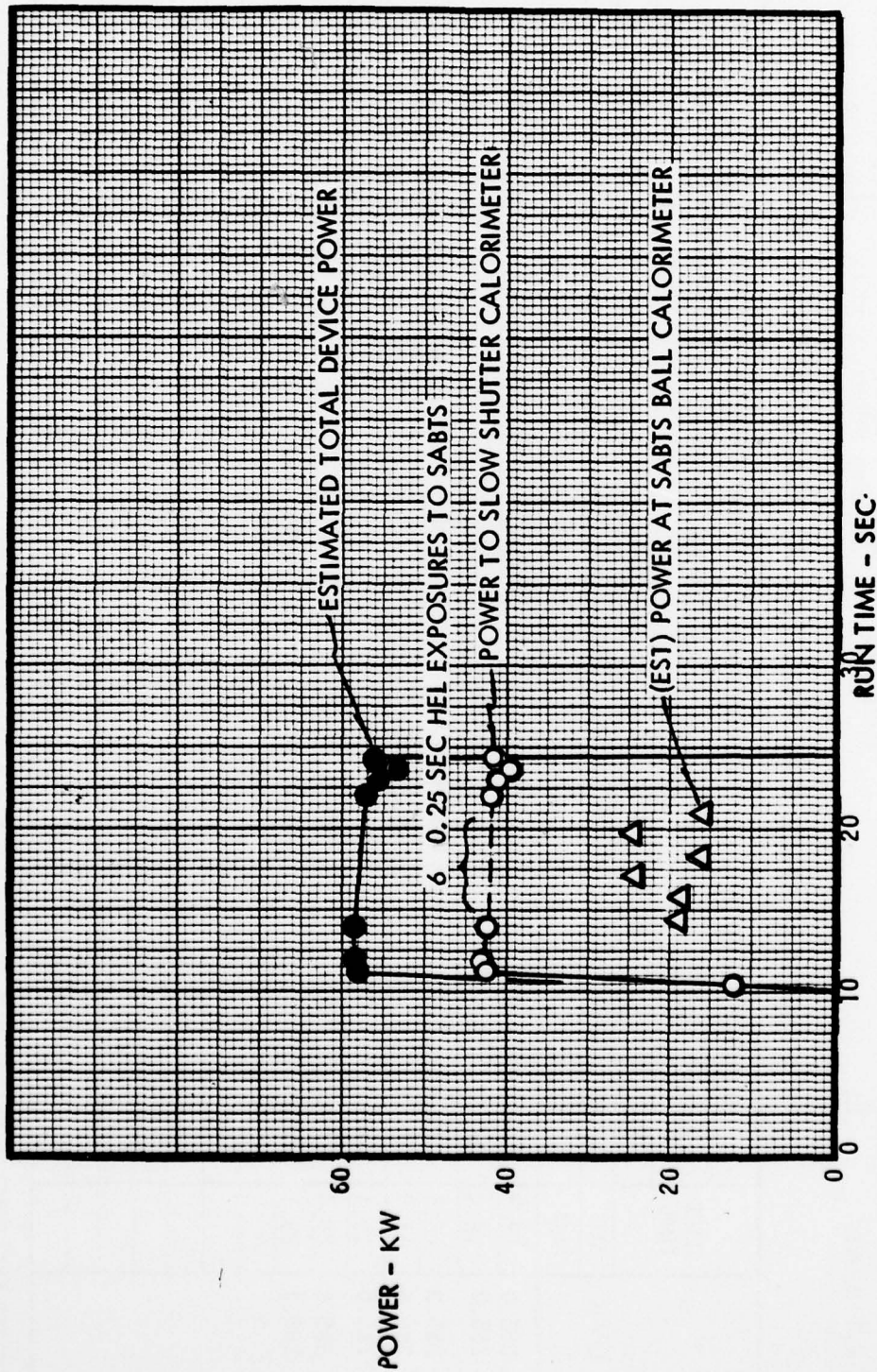

REMARKS: \_\_\_\_\_

PREPARED BY:

J. SINGS  
1-27-77

**PLANNED TIME LINES AND QUICK LOOK DATA SHEET**

RUN NO. <b>VLI-257</b>		TEST PLAN <b>SABTS</b>	DATE <b>1-26-77</b>	TIME <b>1715</b>
D2 FIRE VALVE OPEN (SEC) <b>10.4</b>	D2 FIRE VALVE CLOSED (SEC) <b>24.2</b>	LASING DURATION (SEC) <b>13.80</b>	TOTAL COMPLETED TEST POSITIONS <b>6</b>	PLANNED TOTAL PWR. <b>59</b>

**PLANNED TEST NO. CE-4 TIME LINES AS OF DATE 1-24-77 REVISION ORIG**

EXPERIMENTER <b>D. MULLEN</b>	PLANNED LINEAR MAGNIFICATION <b>2.2</b>	CONFIGURATION <input checked="" type="checkbox"/> REFLECTIVE <input type="checkbox"/> TRANSMISSIVE
	PLANNED PEAK PWR DENSITY <b>17.6 KW/CM<sup>2</sup></b>	

TEST POSITION	SPECIMEN NO.	COATING DESIGN	EXPOSURE TIME (SEC)	TRANSIT TIME (POST EXPOSURE)	TIME FROM F <sub>2</sub>	TIME SLICE	EST. PWR. AT TARGET	TOTAL POWER	ACTUAL SPOT DIAMETER	COMMENTS
1	B1	HUGHES	.25	1.10	14.00	14.4	19.2	58.5	1.6	
2	B2	DOF	.25	1.10	15.35		20.4		↑	
3	B3	DOF	.25	1.10	16.70		22.4		↓	
4	B4	OCLI	.25	1.10	18.05		16.4			
5	B5	OCLI	.25	1.10	19.40		24.4			
6	B6	P-E	.25		20.75		16.0		1.6	
					21.00	23.1		56.2		

ITEM	START (SEC)	STOP (SEC)	ITEM	START (SEC)	STOP (SEC)
TV CAMERA No. 1	ON		O-GRAPH	MAN	MAN.
No. 2	"		SANGAMO No. 1	6.0	28.0
No. 3	"		SANGAMO No. 2	N/A	
No. 4	"		SABTS SEC.	14.0	21.0
			CALORIMETER (SABTS)	14.0	21.0
SABTS INST.			CALORIMETER (SLOW SHUTTER)	10.0	14.0
HI FLOW SOLENOID	10.0	24.5	"	21.0	24.5

LASER PERFORMANCE ANALYSIS, RUN VLI-257

**BEAM INTENSITY PROFILE**

AS SEEN BY IR CAMERA VIEWING SECOND TURN FLAT

TOTAL INTENSITY  
APPROX. TIME (SEC) 20

LINEAR PROFILE\*  
APPROX. TIME (SEC) 20

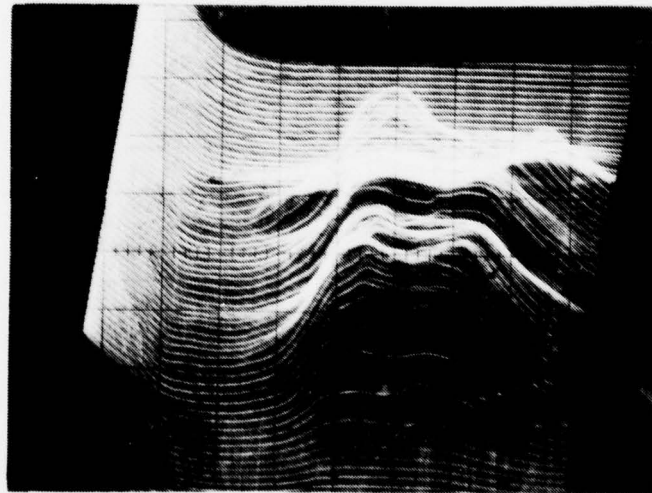
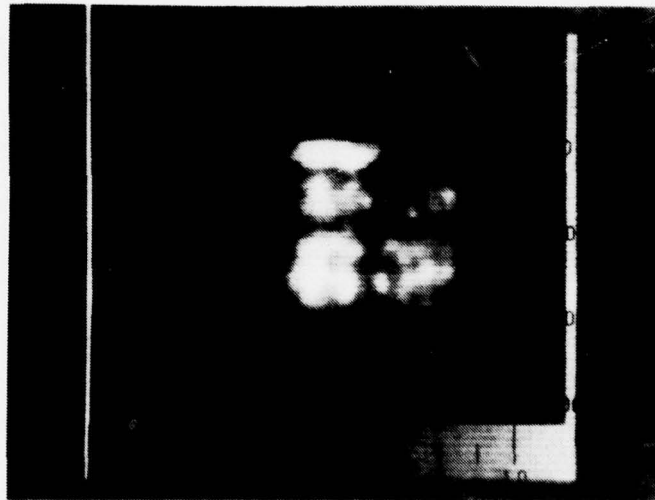

\*PROFILE ALONG SINGLE LINE SCAN SEEN IN TOTAL INTENSITY PICTURE.

LEE BERGERSON

BEAM DIAGNOSTICS ENGINEER

LASER PERFORMANCE ANALYSIS - RUN NUMBER VL 1-258

**ESTIMATED POWER VS. TIME**

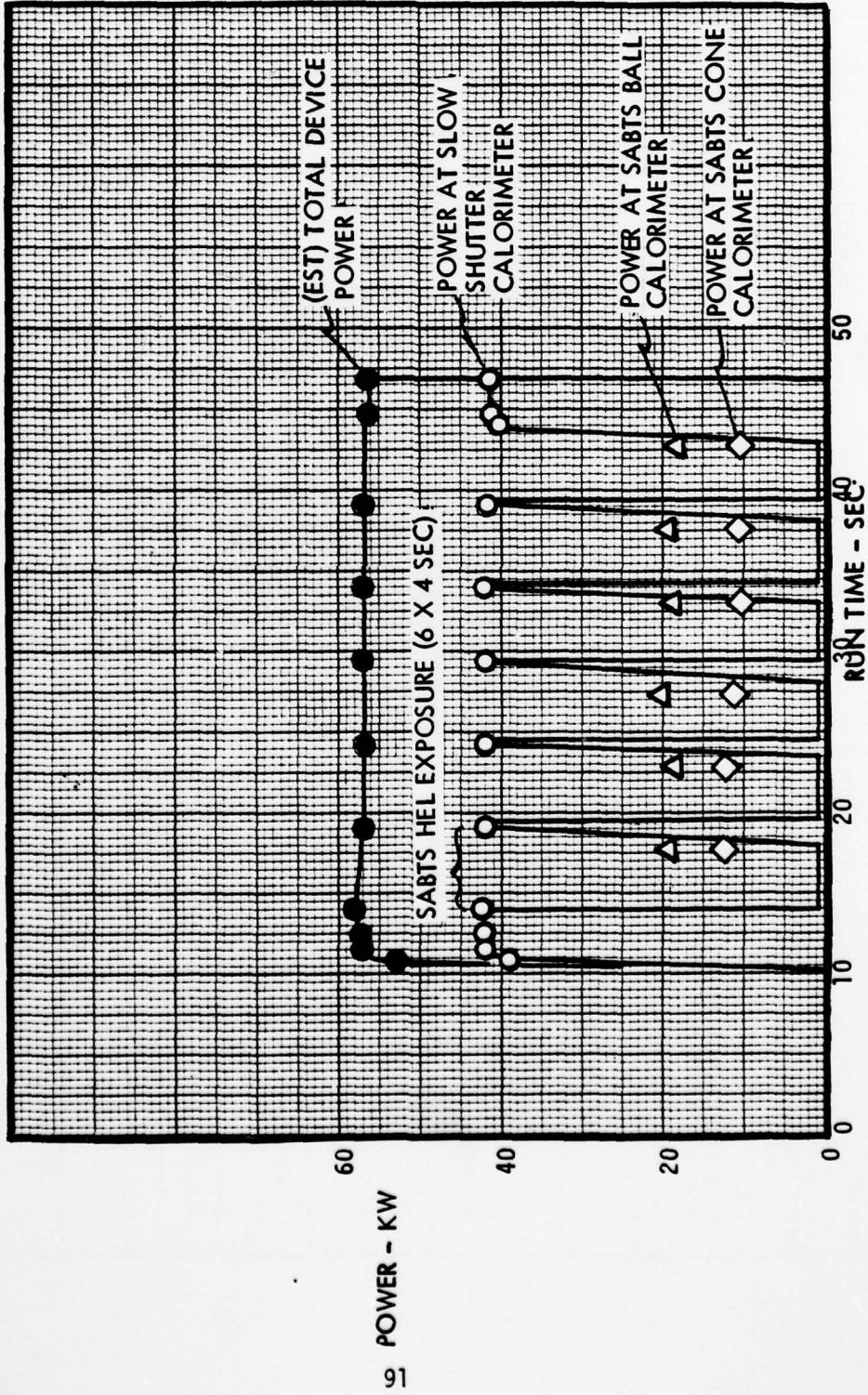

REMARKS:

PREPARED BY: J. SINGH  
1-27-77

**PLANNED TIME LINES AND QUICK LOOK DATA SHEET**

QUICK LOOK TEST DATA	
RUN NO. <b>VLI-258</b>	TEST PLAN <b>SABTS</b>
DATE <b>1-26-77</b>	TIME <b>1840</b>
D2 FIRE VALVE OPEN (SEC) <b>10.4</b>	D2 FIRE VALVE CLOSED (SEC) <b>46.8</b>
LASING DURATION (SEC) <b>36.4</b>	TOTAL COMPLETED TEST POSITIONS <b>6</b>
	PLANNED TOTAL PWR. <b>59</b>

PLANNED TEST NO. **CE-10** TIME LINES AS OF DATE **1-24-77** REVISION **ORIG**

EXPERIMENTER <b>D. MULLEN</b>	PLANNED LINEAR MAGNIFICATION <b>2.2</b>	CONFIGURATION <input checked="" type="checkbox"/> REFLECTIVE <input type="checkbox"/> TRANSMISSIVE
	PLANNED PEAK PWR DENSITY <b>17.6 KW/CM<sup>2</sup></b>	

TEST POSITION	SPECIMEN NO.	COATING DESIGN	PLANNED				ACTUAL				COMMENTS
			EXPOSURE TIME (SEC)	TRANSIT TIME (POST EXPOSURE)	TIME FROM F <sub>2</sub>	TIME SLICE	EST. PWR. AT TARGET	TOTAL POWER	START (SEC)	STOP (SEC)	
1	C1	HUGHES	4.0	1.10	14.00	14.4	19.5	58	1.6		
2	C2	DOF	4.0	1.10	19.10		18.8		↑		
3	C3	DOF	4.0	1.10	24.20		20.5		↓		
4	C4	OCLI	4.0	1.10	29.30		18.8				
5	C5	OCLI	4.0	1.10	34.40		19.5				
6	C6	P-E	4.0		39.50		18.3		1.6		
					43.50	46.3		56.5			

ITEM	START (SEC)	STOP (SEC)	ITEM	START (SEC)	STOP (SEC)
TV CAMERA No. 1	ON		O-GRAPH	MAN.	MAN.
No. 2			SANGAMO No. 1	6.0	49.0
No. 3			SANGAMO No. 2	N/A	
No. 4			SABTS SEQ.	14.0	43.5
			CALORIMETER (SABTS)	14.0	43.5
			CALORIMETER (SLOW SHUTTER)	10.0	14.0
SABTS IIIST.	10.0	47.0		43.5	47.0
HI FLOW SOLENOID					

AD-A068 495

TRW INC REDONDO BEACH CALIF  
SHARED APERTURE BREADBOARD TEST SYSTEM (SABTS) LASER SUPPORT.(U)  
DEC 78 T V ROSZHART, W P BALL, J T SINGS

F/G 21/5

F29601-77-C-0010

UNCLASSIFIED

AFWL-TR-77-135

NL

2 OF 2

AD  
A068-95

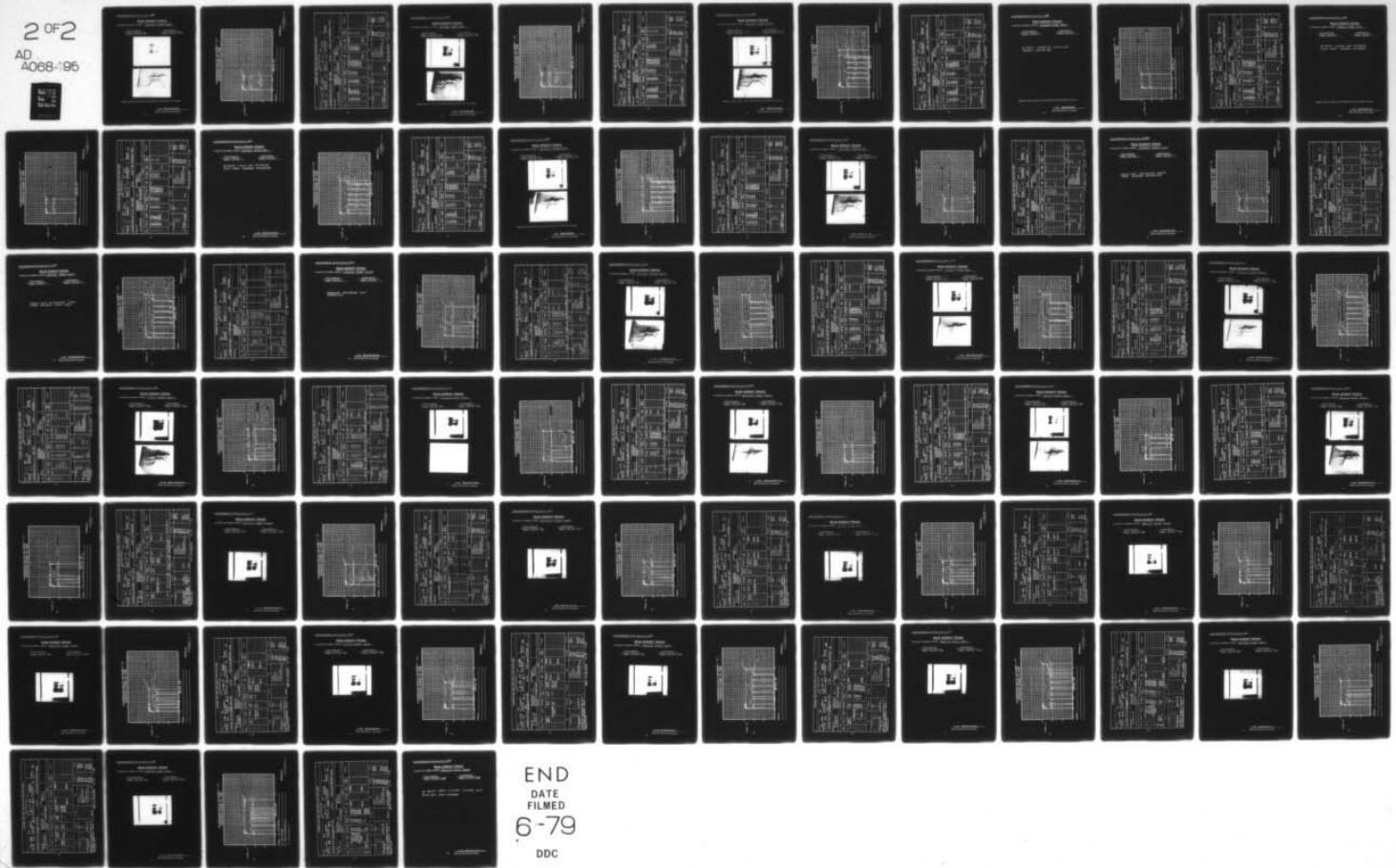

END  
DATE  
FILMED  
6-79  
DDC

**BEAM INTENSITY PROFILE**

AS SEEN BY IR CAMERA VIEWING SECOND TURN FLAT

TOTAL INTENSITY  
APPROX. TIME (SEC) 20

LINEAR PROFILE\*  
APPROX. TIME (SEC) 20

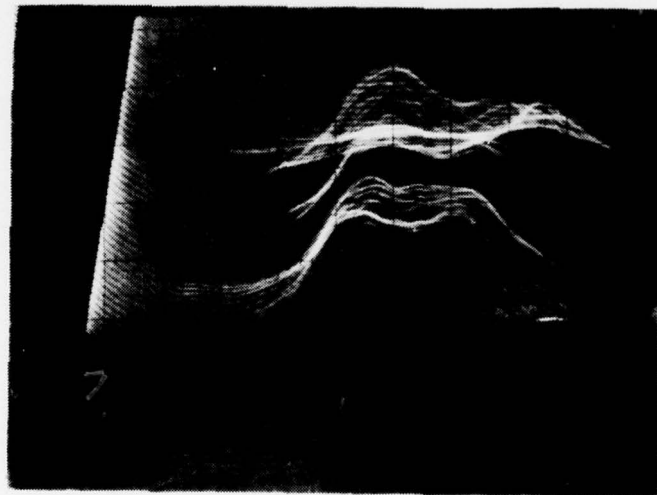

\*PROFILE ALONG SINGLE LINE SCAN SEEN IN TOTAL INTENSITY PICTURE.

LEE BERGERSON

BEAM DIAGNOSTICS ENGINEER

LASER PERFORMANCE ANALYSIS - RUN NUMBER VL 1-259

### ESTIMATED POWER VS. TIME

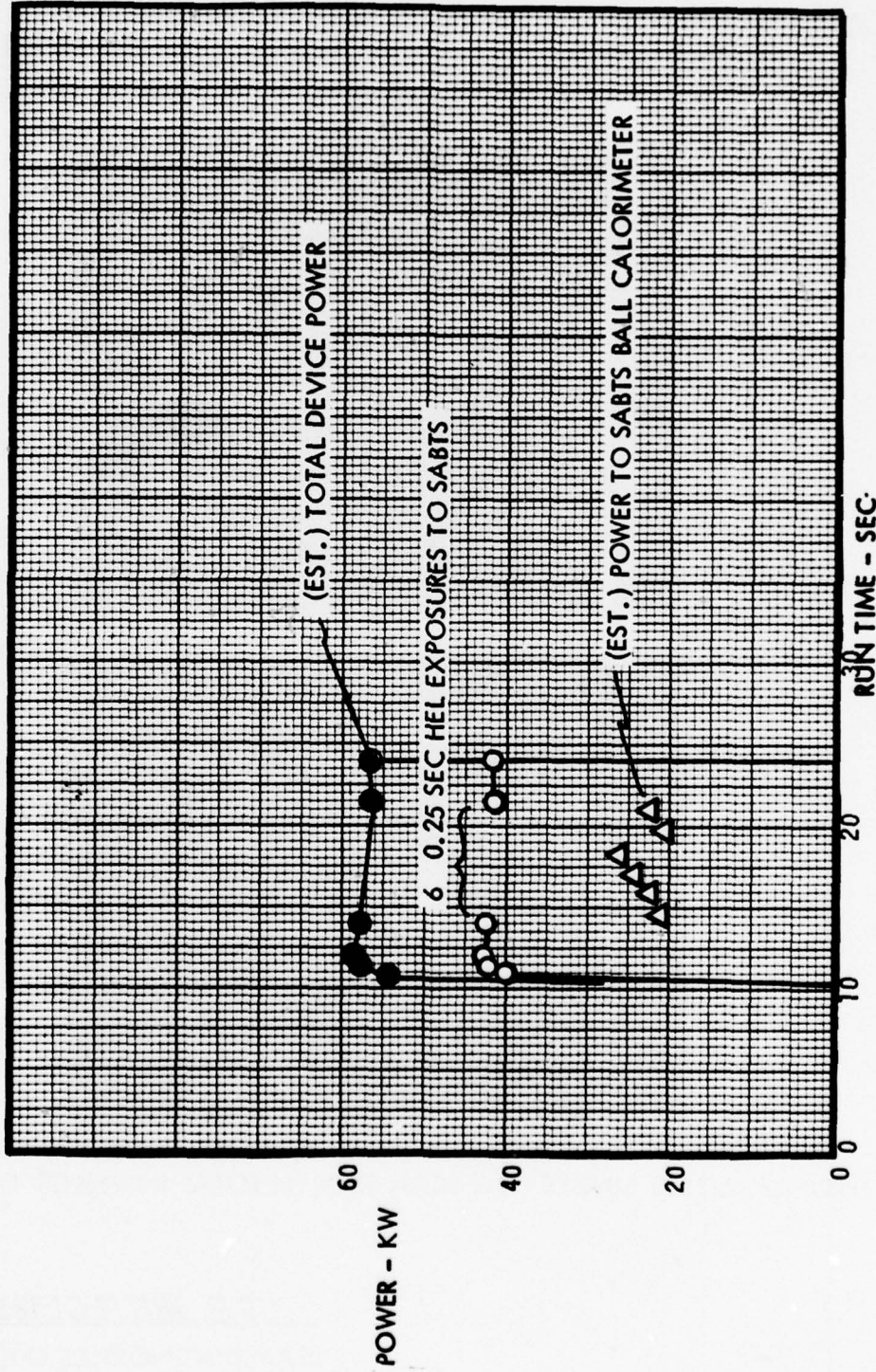

REMARKS: \_\_\_\_\_

PREPARED BY: \_\_\_\_\_

*J. Sines*

1-27-77

**PLANNED TIME LINES AND QUICK LOOK DATA SHEET**

QUICK LOOK TEST DATA

RUN NO. <b>VLI-259</b>	TEST PLAN <b>SABTS</b>	DATE <b>1-27-77</b>	TIME <b>2039</b>	PLANNED TOTAL PWR.
D2 FIRE VALVE OPEN (SEC) <b>10.4</b>	D2 FIRE VALVE CLOSED (SEC) <b>24.2</b>	LASING DURATION (SEC) <b>13.8</b>	TOTAL COMPLETED TEST POSITIONS <b>6</b>	

**PLANNED TEST NO. CE-3 TIME LINES AS OF DATE 1-24-77 REVISION ORIG**

EXPERIMENTER <b>D. MULLEN</b>	PLANNED LINEAR MAGNIFICATION <b>2.2</b>	CONFIGURATION <input checked="" type="checkbox"/> REFLECTIVE <input type="checkbox"/> TRANSMISSIVE
	PLANNED PEAK PWR DENSITY <b>17.6 KW/CM<sup>2</sup></b>	

PLANNED		ACTUAL								
TEST POSITION	SPECIMEN NO.	COATING DESIGN	EXPOSURE TIME (SEC)	TRANSIT TIME (POST EXPOSURE)	TIME FROM F <sub>2</sub>	TIME SLICE	EST. PWR. AT TARGET	TOTAL POWER	ACTUAL SPOT DIAMETER	COMMENTS
1	A1	HUGHES	.25	1.10	14.00	14.4	21.2	58.5	1.6	
2	A2	DOF	.25	1.10	15.35		22.4		↑	
3	A3	DOF	.25	1.10	16.70		24.4		↑	
4	A4	OCLI	.25	1.10	18.05		26.4		↓	
5	A5	OCLI	.25	1.10	19.40		20.4		↓	
6	A6	P-E	.25		20.75		22.4		1.6	
					21.00			56.5		
						23.6				

ITEM	START (SEC)	STOP (SEC)	ITEM	START (SEC)	STOP (SEC)
TV CAMERA No. 1	ON		O-GRAPH	MAN.	MAN.
No. 2	"		SANGAMO No. 1	6.0	28.0
No. 3	"		SANGAMO No. 2	N/A	
No. 4	"		SABTS SEQ.	14.0	21.0
			CALORIMETER (SABTS)	14.0	21.0
			CALORIMETER (SLOW SHUTTER)	10.0	14.0
SABTS INST.			"	"	"
HI FLOW SILENDID	10.0	24.5	"	21.0	24.5

LASER PERFORMANCE ANALYSIS, RUN VL1-259

**BEAM INTENSITY PROFILE**

AS SEEN BY IR CAMERA VIEWING SECOND TURIN FLAT

TOTAL INTENSITY  
APPROX. TIME (SEC) 20

LINEAR PROFILE\*  
APPROX. TIME (SEC) 20

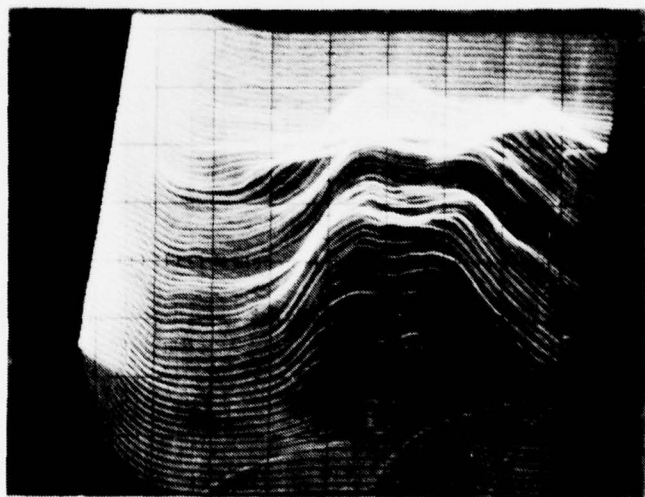
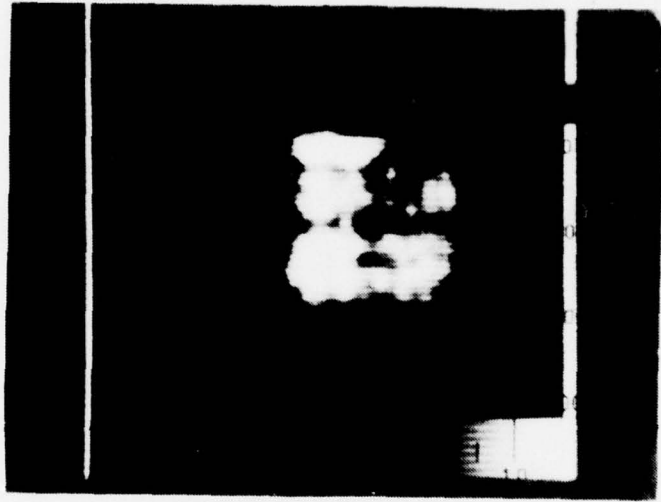

\*PROFILE ALONG SINGLE LINE SCAN SEEN IN TOTAL INTENSITY PICTURE.

LEE BERGERSON  
BEAM DIAGNOSTICS ENGINEER

LASER PERFORMANCE ANALYSIS - RUN NUMBER VL 1-260  
**ESTIMATED POWER VS. TIME**

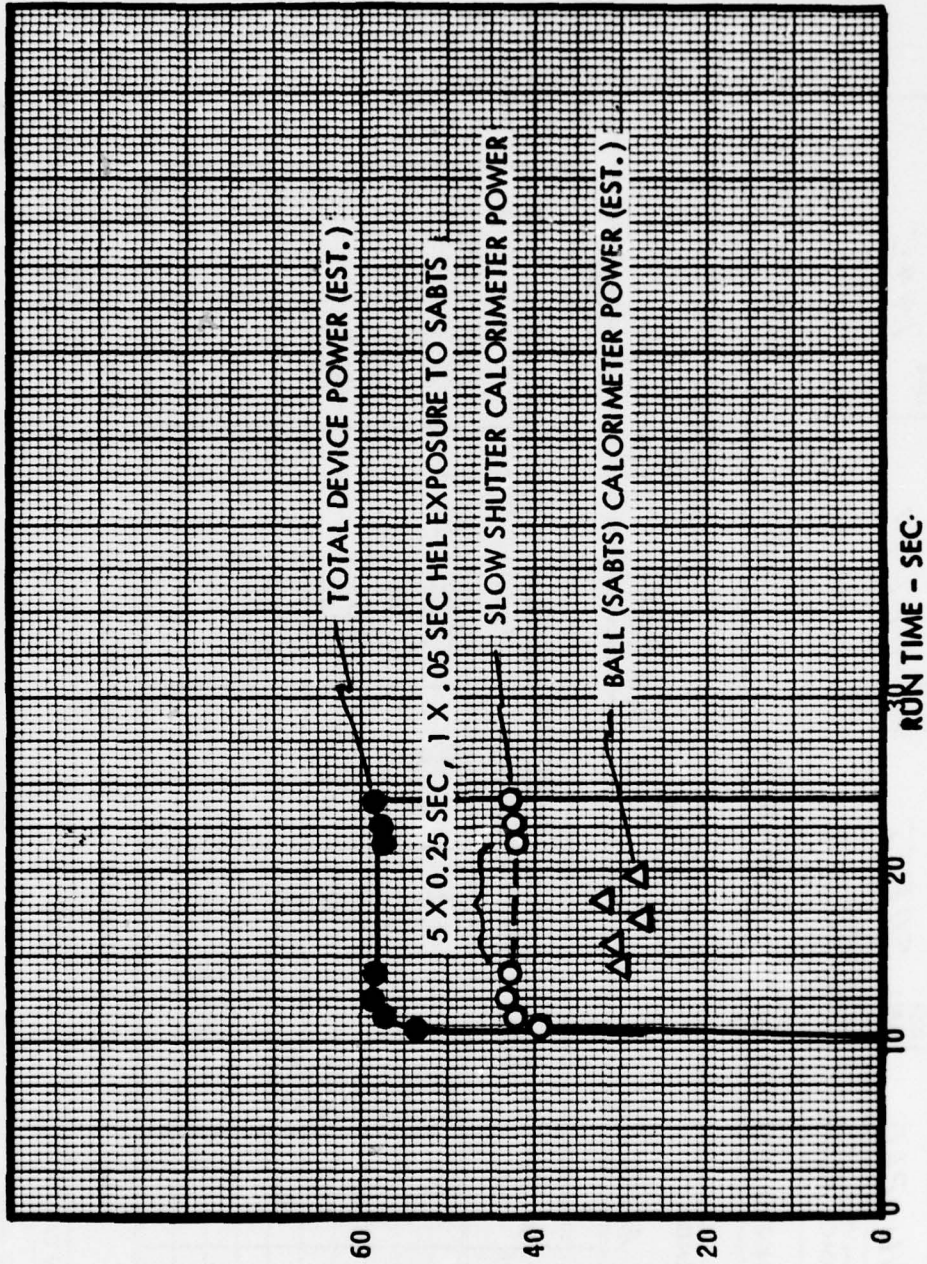

97 POWER - KW

REMARKS: \_\_\_\_\_  
 \_\_\_\_\_  
 \_\_\_\_\_

PREPARED BY: J. SINGG  
 1-28-77

**PLANNED TIME LINES AND QUICK LOOK DATA SHEET**

QUICK LOOK TEST DATA	
RUN NO. <b>VLI-260</b>	TEST PLAN <b>SABTS</b>
DATE <b>1-27-77</b>	TIME <b>1945</b>
D2 FIRE VALVE OPEN (SEC) <b>10.4</b>	D2 FIRE VALVE CLOSED (SEC) <b>24.2</b>
LASING DURATION (SEC) <b>13.8</b>	TOTAL COMPLETED TEST POSITIONS <b>6</b>
PLANNED TOTAL PWR. <b>57</b>	
PLANNED TEST NO. <b>CE-6</b> TIME LINES AS OF DATE <b>1-27-77</b> REVISION <b>A</b>	

EXPERIMENTER	PLANNED LINEAR MAGNIFICATION <b>2.7</b>	CONFIGURATION
<b>D. MULLEN</b>	PLANNED PEAK PWR DENSITY <b>28 KW/CM<sup>2</sup></b>	<input checked="" type="checkbox"/> REFLECTIVE <input type="checkbox"/> TRANSMISSIVE

TEST POSITION	SPECIMEN NO.	COATING DESIGN	PLANNED			ACTUAL			COMMENTS	
			EXPOSURE TIME (SEC)	TRANSIT TIME (POST EXPOSURE)	TIME FROM F <sub>2</sub>	TIME SLICE	EST. PWR. AT TARGET	TOTAL POWER		ACTUAL SPOT DIAMETER
1	B1	PE	.25	1.10	14.00	14.4	30.0	58.0	1.3	
2	B2	DOF	.25	1.10	15.35		30.4			
3	B3	DOF	.25	1.10	16.70		27.2			
4	B4	OCLI	.25	1.10	18.05		32.0			
5	B5	OCLI	.25	1.10	19.40		28.0			
6	B6	PLEXI	.05		20.75				1.3	
					20.80					

ITEM	START (SEC)	STOP (SEC)	ITEM	START (SEC)	STOP (SEC)
TV CAMERA No. 1	ON		O-GRAPH	MAN	MAN.
No. 2	"		SANGAMO No. 1	6.0	28.0
No. 3	"		SANGAMO No. 2	N/A	
No. 4	"		SABTS SEQ.	14.0	21.0
			CALORIMETER (SABTS)	14.0	21.0
			CALORIMETER (SLOW SHUTTER)	10.0	14.0
SABTS INST.			"	"	"
HI FLOW SOLENOID	10.0	24.5	"	20.8	24.5

LASER PERFORMANCE ANALYSIS, RUN VL1-260

**BEAM INTENSITY PROFILE**

AS SEEN BY IR CAMERA VIEWING SECOND TURN FLAT

TOTAL INTENSITY

APPROX. TIME (SEC) 20

LINEAR PROFILE\*

APPROX. TIME (SEC) 20

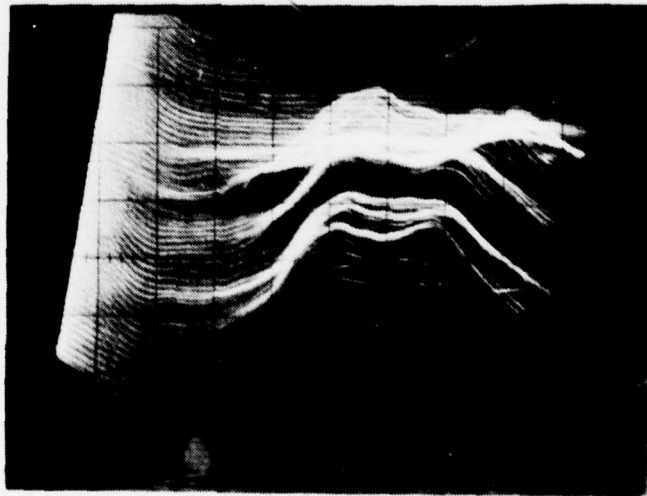

\*PROFILE ALONG SINGLE LINE SCAN SEEN IN TOTAL INTENSITY PICTURE.

LEE BERGERSON

BEAM DIAGNOSTICS ENGINEER

LASER PERFORMANCE ANALYSIS - RUN NUMBER VL 1-261

### ESTIMATED POWER VS. TIME

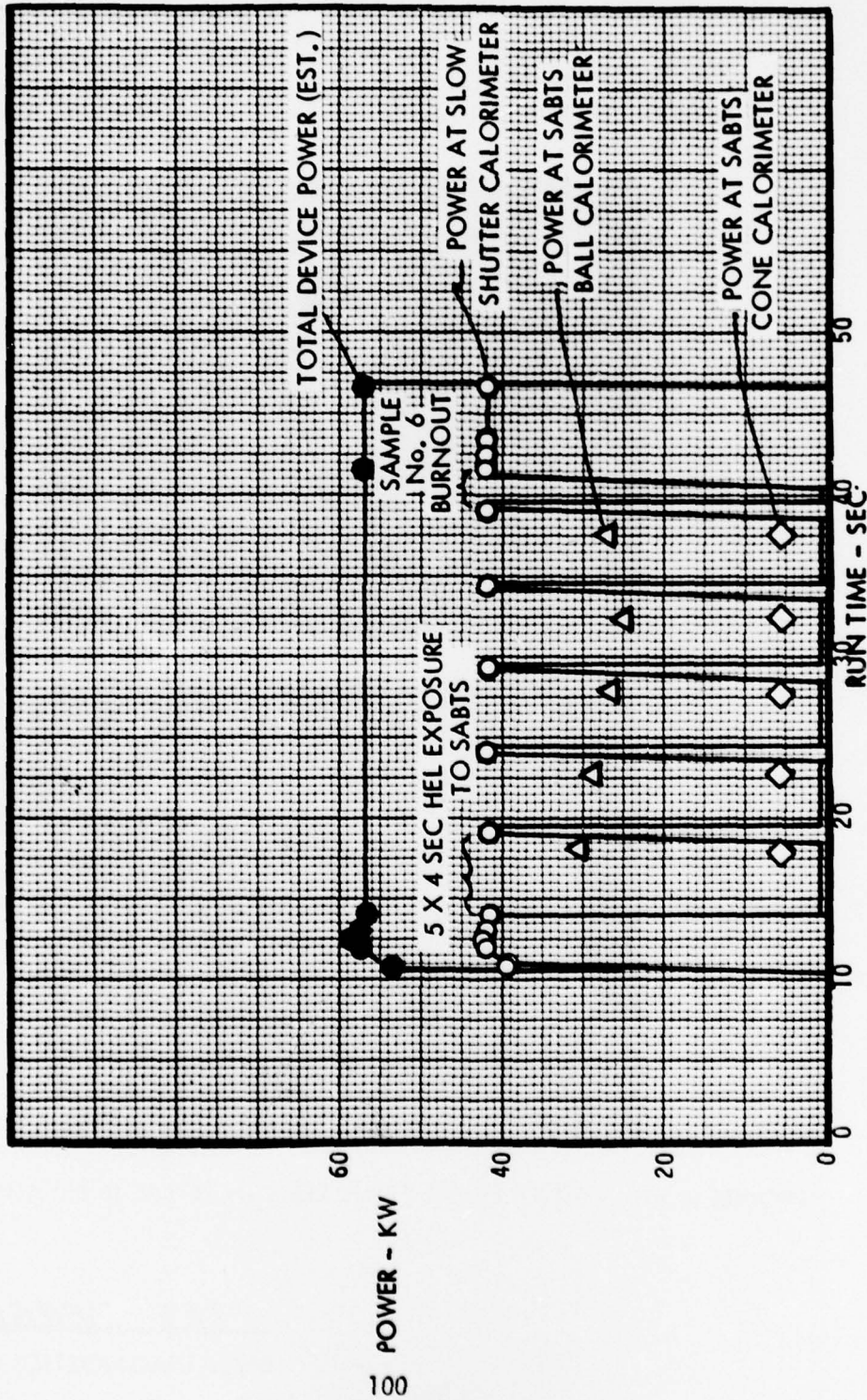

REMARKS:

PREPARED BY:

*L. Swags*

**PLANNED TIME LINES AND QUICK LOOK DATA SHEET**

QUICK LOOK TEST DATA			
RUN NO.	TEST PLAN	DATE	TIME
V11-261	SABTS	1-28-77	2056
D2 FIRE VALVE OPEN (SEC)	D2 FIRE VALVE CLOSED (SEC)	LASING DURATION (SEC)	TOTAL COMPLETED TEST POSITIONS
10.9	46.7	36.3	6
			PLANNED TOTAL PWR. 59

PLANNED TEST NO. CE-11 TIME LINES AS OF DATE 1-26-77 REVISION ORIG

EXPERIMENTER	PLANNED LINEAR MAGNIFICATION	2.7	CONFIGURATION
D. MULLEN	PLANNED PEAK PWR DENSITY	28 KW/CM <sup>2</sup>	<input checked="" type="checkbox"/> REFLECTIVE <input type="checkbox"/> TRANSMISSIVE

TEST POSITION	SPECIMEN NO.	COATING DESIGN	PLANNED				ACTUAL				COMMENTS	
			EXPOSURE TIME (SEC)	TRANSIT TIME (POST EXPOSURE)	TIME FROM F <sub>2</sub>	TIME SLICE	EST. PWR. AT TARGET	TOTAL POWER	START (SEC)	STOP (SEC)		
1	C1	PE	4.0	1.10	14.00	18.0	30.7	58	1.3			
2	C2	DNF	4.0	1.10	19.10		28.8		↑			
3	C3	DNF	4.0	1.10	24.20		26.7		↑			
4	C4	OCLI	4.0	1.10	29.30		24.9		↑			
5	C5	OCLI	4.0	1.10	34.40		27.0		1.3			
6	C6	HUGHES	4.0		39.50					57.6		
					43.50							

ITEM	START (SEC)	STOP (SEC)	ITEM	START (SEC)	STOP (SEC)
TV CAMERA No. 1	ON		O-GRAPH	MAN	MAN.
No. 2	"		SANGAMO No. 1	6.0	49.0
No. 3	"		SANGAMO No. 2	N/A	
No. 4	"		SABTS SEQ.	14.0	43.5
			CALORIMETER (SABTS)	14.0	43.5
			CALORIMETER (SLOW SHUTTER)	10.0	14.0
SABTS INST.				43.5	47.0
HI FLOW SOLENOID	10.0	47.0			

LASER PERFORMANCE ANALYSIS, RUN VLI-261.

**BEAM INTENSITY PROFILE**

AS SEEN BY IR CAMERA VIEWING SECOND TURN FLAT

TOTAL INTENSITY

APPROX. TIME (SEC) \_\_\_\_\_

LINEAR PROFILE\*

APPROX. TIME (SEC) \_\_\_\_\_

*NO DATA - OPERATING SWITCH NOT  
TURNED ON AFTER EM.*

\*PROFILE ALONG SINGLE LINE SCAN SEEN IN TOTAL INTENSITY PICTURE.

LEE BERGERSON

BEAM DIAGNOSTICS ENGINEER

LASER PERFORMANCE ANALYSIS - RUN NUMBER VL 1-262  
**ESTIMATED POWER VS. TIME**

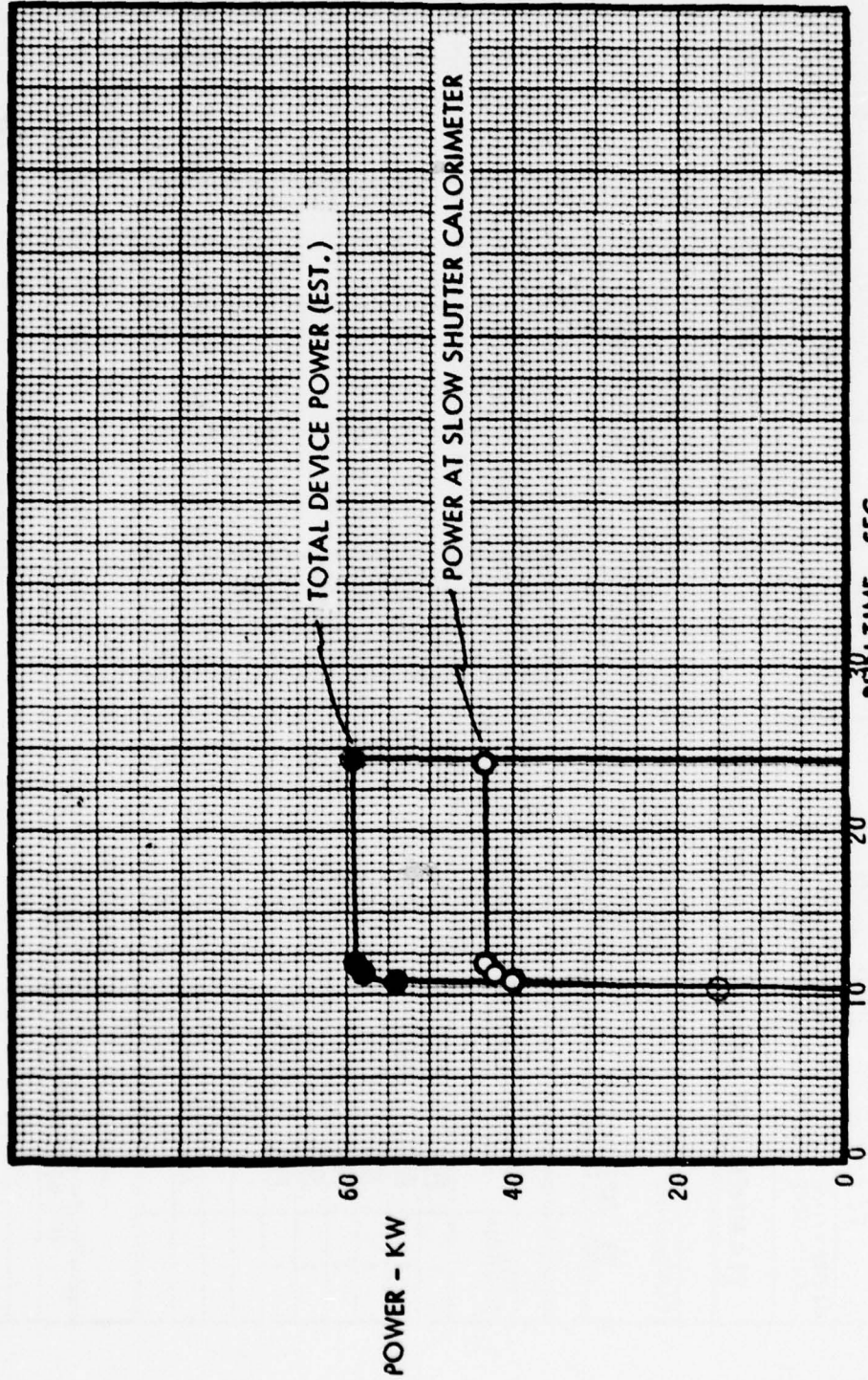

REMARKS: NO HEL DELIVERED TO SABTS TEST AREA

PREPARED BY: L. Sims  
1-28-77

**PLANNED TIME LINES AND QUICK LOOK DATA SHEET**

QUICK LOOK TEST DATA			
RUN NO. <b>VLI-262</b>	TEST PLAN <b>SABTS</b>	DATE <b>1-28-77</b>	TIME <b>1731</b>
D2 FIRE VALVE OPEN (SEC) <b>10.4</b>	D2 FIRE VALVE CLOSED (SEC) <b>24.3</b>	LASING DURATION (SEC) <b>13.9</b>	TOTAL COMPLETED TEST POSITIONS <b>0</b>
			PLANNED TOTAL PWR. <b>59</b>

**PLANNED TEST NO. CE-8 TIME LINES AS OF DATE 1-28-77 REVISION 0R16**

EXPERIMENTER <b>D. MULLEN</b>	PLANNED LINEAR MAGNIFICATION <b>3.5</b>	CONFIGURATION <input checked="" type="checkbox"/> REFLECTIVE <input type="checkbox"/> TRANSMISSIVE
	PLANNED PEAK PWR DENSITY <b>38 KW/CM<sup>2</sup></b>	

PLANNED		ACTUAL				COMMENTS				
TEST POSITION	SPECIMEN NO.	COATING DESIGN	EXPOSURE TIME (SEC)	TRANSIT TIME (POST EXPOSURE)	TIME FROM F <sub>2</sub>		TIME SLICE	EST. PWR. AT TARGET	TOTAL POWER	ACTUAL SPOT DIAMETER
1	B1	PE	.25	1.10	14.00			59.2		
2	B2	DOF	.25	1.10	15.35					
3	B3	DOF	.25	1.10	16.70					
4	B4	OCLI	.25	1.10	18.05					
5	B5	OCLI	.25	1.10	19.40					
6	B6	PLEXI	.11		20.75			59.6		
					20.86					
NOTE: SLOW SHUTTER DID NOT OPEN - 6N <sub>2</sub> PRESSURE NOT LOADED TO SABTS ACCUMULATOR.										

ITEM	START (SEC)	STOP (SEC)	ITEM	START (SEC)	STOP (SEC)
TV CAMERA No. 1	DN		O-GRAPH	NAN.	MAN.
No. 2	"		SANGAMO No. 1	6.0	28.0
No. 3	"		SANGAMO No. 2	N/A	
No. 4	"		SABTS SEQ.	14.0	20.86
			CALORIMETER (SABTS)	14.0	20.86
			CALORIMETER (SLOW SHUTTER)	10.0	14.0
SABTS INST.			"	20.86	24.5
<b>HI FLOW SOLENOID</b>	<b>10.0</b>	<b>24.5</b>	"	"	"

LASER PERFORMANCE ANALYSIS, RUN VLI-262

**BEAM INTENSITY PROFILE**

AS SEEN BY IR CAMERA VIEWING SECOND TURN FLAT

TOTAL INTENSITY

APPROX. TIME (SEC) \_\_\_\_\_

LINEAR PROFILE\*

APPROX. TIME (SEC) \_\_\_\_\_

*NO DATA - COULD NOT RETRIEVE  
DATA FROM SANGAMO RECORDER*

\*PROFILE ALONG SINGLE LINE SCAN SEEN IN TOTAL INTENSITY PICTURE.

LEE BERGERSON

BEAM DIAGNOSTICS ENGINEER

LASER PERFORMANCE ANALYSIS - RUN NUMBER VL 1-263

**ESTIMATED POWER VS. TIME**

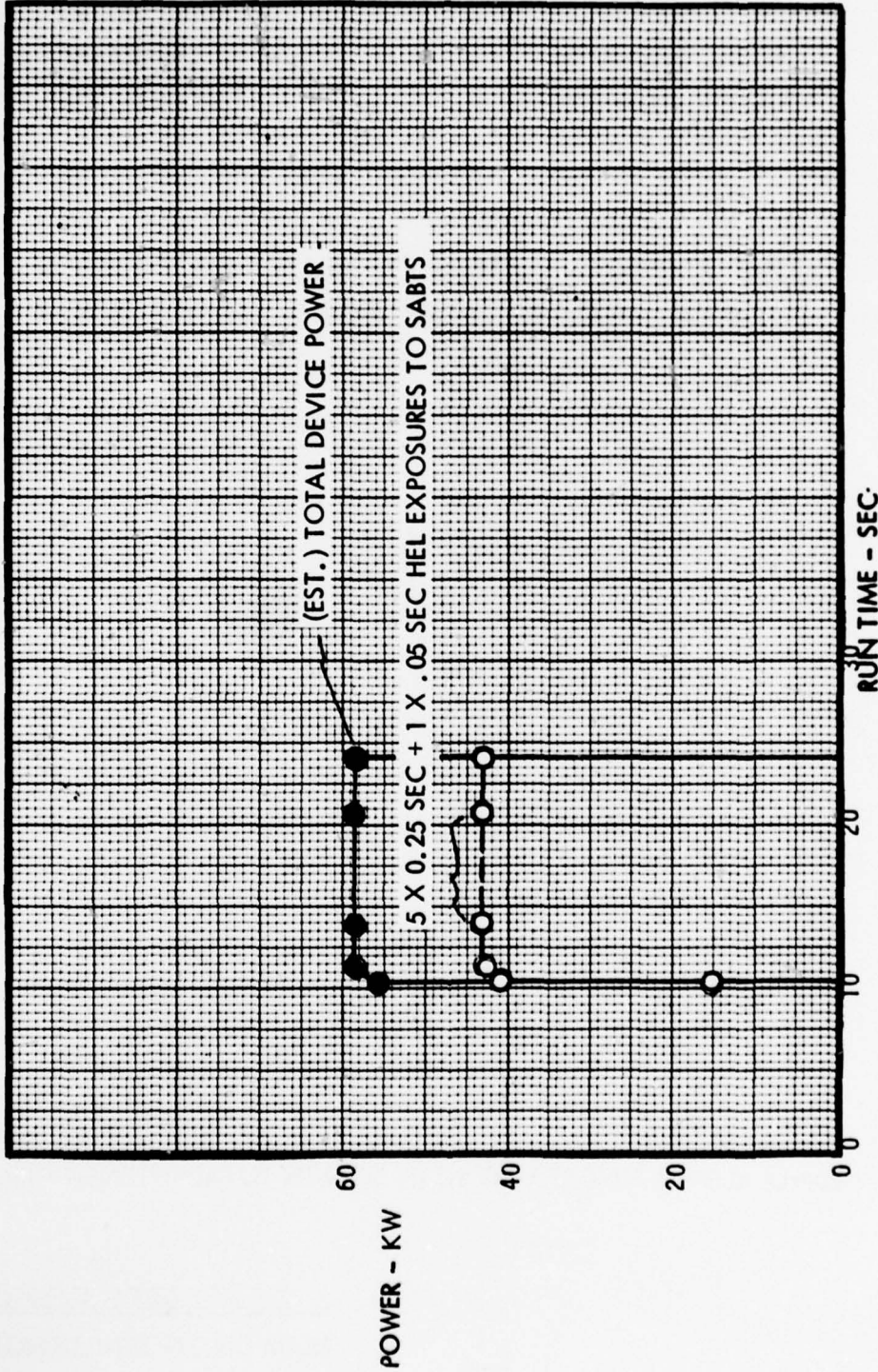

REMARKS: \_\_\_\_\_

PREPARED BY: \_\_\_\_\_

*J. SINGH*  
1-28-77

PLANNED TIME LINES AND QUICK LOOK DATA SHEET										
QUICK LOOK TEST DATA										
RUN NO. <b>VLI-263</b>	TEST PLAN <b>SABTS</b>	DATE <b>1-28-77</b>	TIME <b>1839</b>							PLANNED TOTAL PWR. <b>59</b>
D2 FIRE VALVE OPEN (SEC) <b>10.4</b>	D2 FIRE VALVE CLOSED (SEC) <b>24.2</b>	LASING DURATION (SEC) <b>13.8</b>	TOTAL COMPLETED TEST POSITIONS <b>6</b>							
PLANNED TEST NO. <b>CE-8</b> TIME LINES AS OF DATE <b>1-28-77</b> REVISION <b>ORIG</b>										
EXPERIMENTER		PLANNED LINEAR MAGNIFICATION <b>3.5</b>		CONFIGURATION						
<b>D. MULLEN</b>		PLANNED PEAK PWR DENSITY <b>38 KW/CM<sup>2</sup></b>		<input checked="" type="checkbox"/> REFLECTIVE <input type="checkbox"/> TRANSMISSIVE						
PLANNED				ACTUAL						
TEST POSITION	SPECIMEN NO.	COATING DESIGN	EXPOSURE TIME (SEC)	TRANSIT TIME (POST EXPOSURE)	TIME FROM F <sub>2</sub>	TIME SLICE	EST. PWR. AT TARGET	TOTAL POWER	ACTUAL SPOT DIAMETER	COMMENTS
1	B1	PE	.25	1.10	14.00	14.4	25.2	59.4	1.0	
2	B2	DOF	.25	1.10	15.35		27.6		↑	
3	B3	DOF	.25	1.10	16.70		25.2		↓	
4	B4	OCLI	.25	1.10	18.05		24.4			
5	B5	OCLI	.25	1.10	19.40		26.4		1.0	
6	B6	PLEXI	.11		20.75			59.2		
					20.86					
ITEM		START (SEC)	STOP (SEC)	ITEM	START (SEC)	STOP (SEC)				
TV CAMERA No. 1		DN		O-GRAPH	MAN.	MAN.				
No. 2		"		SANGAMO No. 1	6.0	28.0				
No. 3		"		SANGAMO No. 2	N/A					
No. 4		"		SABTS SEQ.	14.0	20.86				
SABTS INST.				CALORIMETER (SABTS)	14.0	20.86				
<b>HI FLOW SOLENOID</b>		10.0	24.5	CALORIMETER (SLOW SHUTTER)	10.0	14.0				
				"	"	24.5				

LASER PERFORMANCE ANALYSIS, RUN VLI-263

**BEAM INTENSITY PROFILE**

AS SEEN BY IR CAMERA VIEWING SECOND TURN FLAT

TOTAL INTENSITY

APPROX. TIME (SEC) \_\_\_\_\_

LINEAR PROFILE\*

APPROX. TIME (SEC) \_\_\_\_\_

*NO DATA - COULD NOT RETRIEVE  
DATA FROM SANGAM RECORDER*

LEE BERGERSON

BEAM DIAGNOSTICS ENGINEER

LASER PERFORMANCE ANALYSIS - RUN NUMBER VL 1-264

**ESTIMATED POWER VS. TIME**

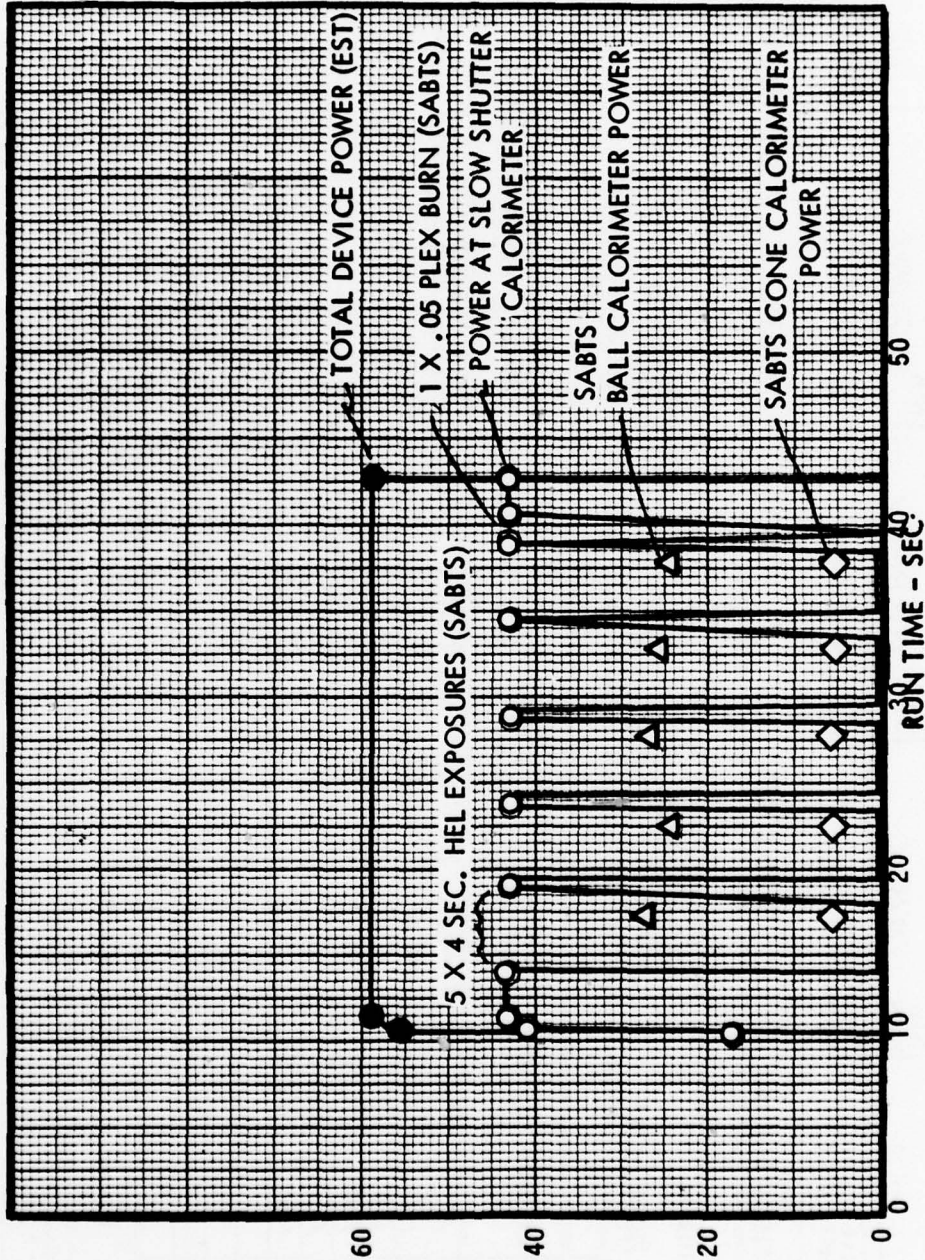

REMARKS:

PREPARED BY:

*J. Sings*  
1-28-77

POWER - KW

**PLANNED TIME LINES AND QUICK LOOK DATA SHEET**

**QUICK LOOK TEST DATA**

RUN NO. <b>11-264</b>	TEST PLAN <b>SABTS</b>	DATE <b>1-28-77</b>	TIME <b>2007</b>	PLANNED TOTAL PWR. <b>59</b>
D2 FIRE VALVE OPEN (SEC) <b>10.4</b>	D2 FIRE VALVE CLOSED (SEC) <b>42.7</b>	LASING DURATION (SEC) <b>32.3</b>	TOTAL COMPLETED TEST POSITIONS <b>6</b>	

**PLANNED TEST NO. CE-12 TIME LINES AS OF DATE 1-28-77 REVISION ORIG**

EXPERIMENTER <b>D. MULLEN</b>	PLANNED LINEAR MAGNIFICATION <b>3.5</b>	CONFIGURATION <input checked="" type="checkbox"/> REFLECTIVE <input type="checkbox"/> TRANSMISSIVE
	PLANNED PEAK PWR DENSITY <b>38 KW/CM<sup>2</sup></b>	

TEST POSITION	SPECIMEN NO.	COATING DESIGN	EXPOSURE TIME (SEC)	TRANSIT TIME (POST EXPOSURE)	TIME FROM F <sub>2</sub>	TIME SLICE	EST. PWR. AT TARGET	TOTAL POWER	ACTUAL SPOT DIAMETER	COMMENTS
1	A1	PE	4.0	1.10	14.00	17.6	27.1	59.1	1.0	
2	A2	DOF	4.0	1.10	19.10		24.1		↑	
3	A3	DOF	4.0	1.10	24.20		25.8		↑	
4	A4	DCLI	4.0	1.10	29.30		25.8			
5	A5	DCLI	4.0	1.10	34.40		24.6		1.0	
6	A6	PLEXI	.11		39.50			59.2		
					39.61					

ITEM	START (SEC)	STOP (SEC)	ITEM	START (SEC)	STOP (SEC)
TV CAMERA No. 1	ON		O-GRAPH	MAN.	MAN.
No. 2	//		SANGAMO No. 1	6.0	45.0
No. 3	//		SANGAMO No. 2	N/A	
No. 4	//		SABTS SEC.	14.0	39.6
			CALORIMETER (SABTS)	14.0	39.6
			CALORIMETER (SLOW SHUTTER)	10.0	14.0
SABTS INST.			" "	39.6	43.0
HI FLOW SOLENOID	10.0	43.0	" "		

REF: TCR ML 21365 PAGE 3 OF 4

LASER PERFORMANCE ANALYSIS, RUN VLI-264

**BEAM INTENSITY PROFILE**

AS SEEN BY IR CAMERA VIEWING SECOND TURN FLAT

TOTAL INTENSITY  
APPROX. TIME (SEC) 20

LINEAR PROFILE\*  
APPROX. TIME (SEC) 20

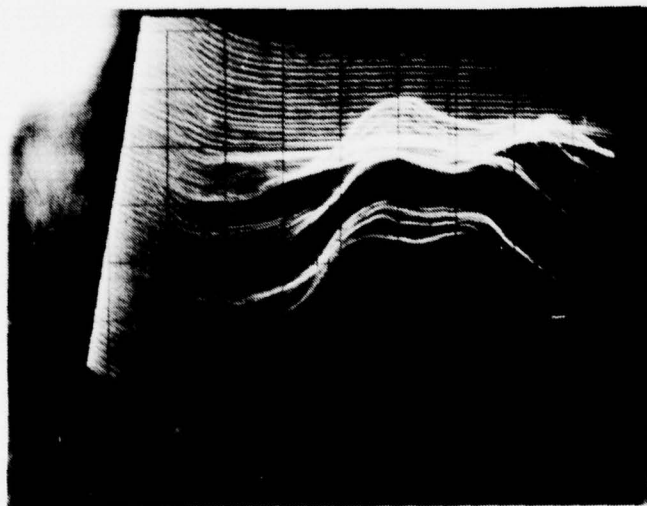
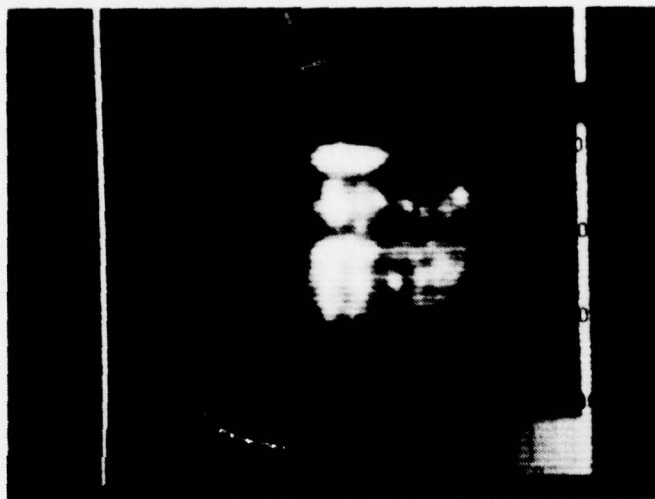

\*PROFILE ALONG SINGLE LINE SCAN SEEN IN TOTAL INTENSITY PICTURE.

LEE BERGERSON  
BEAM DIAGNOSTICS ENGINEER

LASER PERFORMANCE ANALYSIS - RUN NUMBER VL 1-265

### ESTIMATED POWER VS. TIME

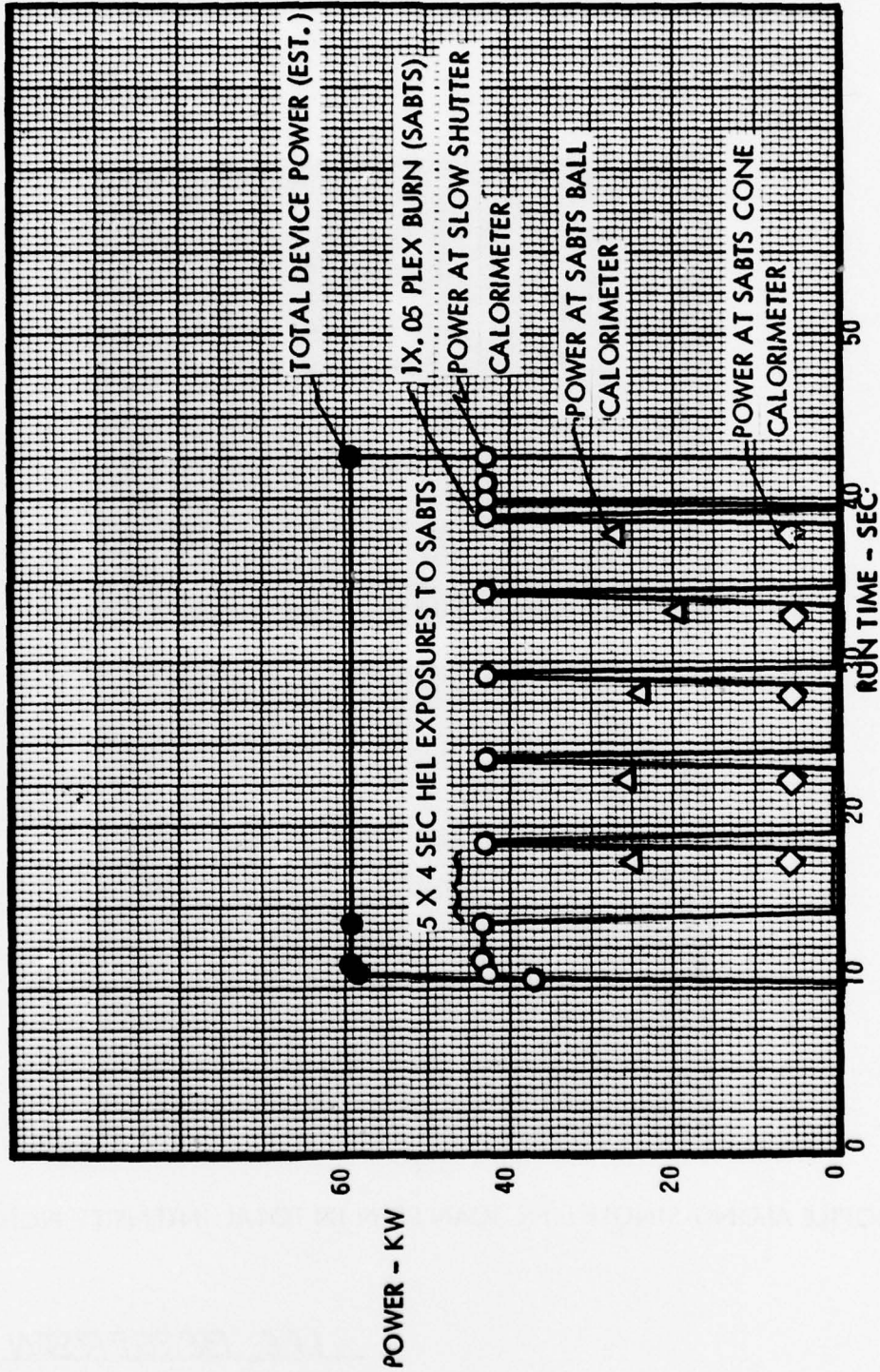

REMARKS:

PREPARED BY:

*J. SINGS*  
1-28-77

**PLANNED TIME LINES AND QUICK LOOK DATA SHEET**

QUICK LOOK TEST DATA	
RUN NO. <b>VLI-265</b>	TEST PLAN <b>SARTS</b>
D2 FIRE VALVE OPEN (SEC) <b>10.4</b>	D2 FIRE VALVE CLOSED (SEC) <b>42.5</b>
DATE <b>1-28-77</b>	TIME <b>2145</b>
LASING DURATION (SEC) <b>32.1</b>	TOTAL COMPLETED TEST POSITIONS <b>6</b>
	PLANNED TOTAL PWR. <b>59</b>

**PLANNED TEST NO. CF-13 TIME LINES AS OF DATE 1-28-77 REVISION DRIG**

EXPERIMENTER <b>D. MULLEN</b>	PLANNED LINEAR MAGNIFICATION <b>3.5</b>	CONFIGURATION <input checked="" type="checkbox"/> REFLECTIVE <input type="checkbox"/> TRANSMISSIVE
	PLANNED PEAK PWR DENSITY <b>38 KW/CM<sup>2</sup></b>	

TEST POSITION	SPECIMEN NO.	COATING DESIGN	PLANNED						ACTUAL			COMMENTS
			EXPOSURE TIME (SEC)	TRANSIT TIME (POST EXPOSURE)	TIME FROM F <sub>2</sub>	TIME SLICE	EST. PWR. AT TARGET	TOTAL POWER	ACTUAL SPOT DIAMETER			
1	C1	PE	4.0	1.10	19.00	17.9	24.8	59.3	1.0			
2	C2	DOF	4.0	1.10	19.10		25.9		↑			
3	C3	DOF	4.0	1.10	24.20		23.6		↓			
4	C4	OCLI	4.0	1.10	29.30		19.3		↓			
5	C5	OCLI	4.0	1.10	34.40		27.2		1.0			
6	C6	PLEXI	.11		39.50			59.1				
					39.61							

ITEM	START (SEC)	STOP (SEC)	ITEM	START (SEC)	STOP (SEC)
TV CAMERA No. 1	ON		O-GRAPH	MAN.	MAN.
No. 2	"		SANGAMO No. 1	6.0	45.0
No. 3	"		SANGAMO No. 2	N/A	
No. 4	"		SABTS SEC.	14.0	39.6
			CALORIMETER (SABTS)	14.0	39.6
SABTS INST.			CALORIMETER (SLOW SHUTTER)	10.0	14.0
<b>HI FLOW SOLIFNOID</b>	<b>10.0</b>	<b>43.0</b>	"	"	"
			"	39.6	43.0

LASER PERFORMANCE ANALYSIS, RUN VLI-265

**BEAM INTENSITY PROFILE**

AS SEEN BY IR CAMERA VIEWING SECOND TURN FLAT

TOTAL INTENSITY  
APPROX. TIME (SEC) 20



LINEAR PROFILE\*  
APPROX. TIME (SEC) 20

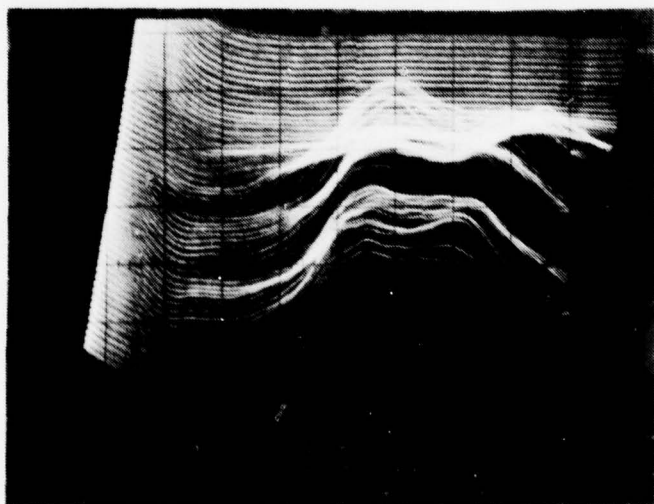

LEE BERGERSON  
BEAM DIAGNOSTICS ENGINEER

LASER PERFORMANCE ANALYSIS - RUN NUMBER VL 1-266

### ESTIMATED POWER VS. TIME

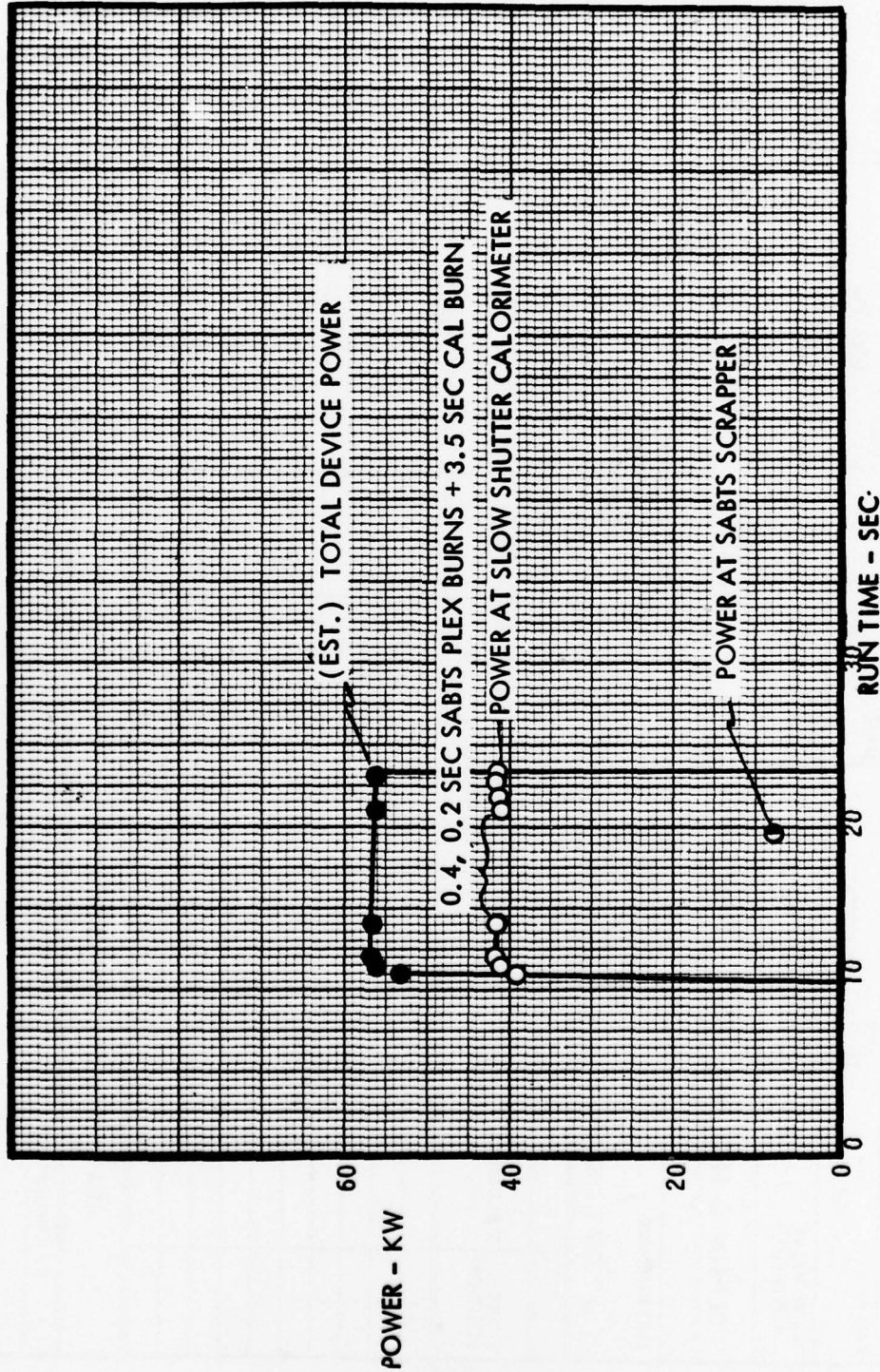

REMARKS: \_\_\_\_\_

PREPARED BY:

J. SINGS  
2-8-77

# PLANNED TIME LINES AND QUICK LOOK DATA SHEET

QUICK LOOK TEST DATA			
RUN NO.	TEST PLAN	DATE	TIME
266	SABTS	2-8-77	2034
D2 FIRE VALVE OPEN	D2 FIRE VALVE CLOSED (SEC)	LASING DURATION (SEC)	TOTAL COMPLETED TEST POSITIONS
10.4	23.2	12.8	3
			PLANNED TOTAL PWR. 59

PLANNED TEST NO. *R-5* TIME LINES AS OF DATE *2-7-77* REVISION *0216*

EXPERIMENTER <i>D. MULLEN</i>	PLANNED LINEAR MAGNIFICATION	CONFIGURATION
	PLANNED PEAK PWR DENSITY <i>10 KW/CM<sup>2</sup></i>	<input type="checkbox"/> REFLECTIVE <input type="checkbox"/> TRANSMISSIVE

TEST POSITION	SPECIMEN NO.	COATING DESIGN	EXPOSURE TIME (SEC)	TRANSIT TIME (POST EXPOSURE)	TIME FROM $f_2$	TIME SLICE	EST. PWR. AT TARGET	TOTAL POWER	ACTUAL SPOT DIAMETER	COMMENTS
1		<i>CONE CAL</i>	<i>4.0</i>		<i>10.0</i>	<i>13.5</i>		<i>57.6</i>		
2		<i>PLEXI 1</i>	<i>0.4</i>	<i>1.10</i>	<i>14.0</i>					
3		<i>PLEXI 2</i>	<i>0.2</i>	<i>1.10</i>	<i>15.5</i>					
4		<i>TUBICAL</i>	<i>3.5</i>		<i>16.8</i>					
5		<i>CONE CAL</i>	<i>3.0</i>		<i>20.5</i>	<i>22.7</i>		<i>57.7</i>		
6										

ITEM	START (SEC)	STOP (SEC)	ITEM	START (SEC)	STOP (SEC)
TV CAMERA No. 1	<i>ON</i>		O-GRAPH	<i>MAN</i>	<i>MAN</i>
No. 2	<i>"</i>		SANGAMO No. 1	<i>LO</i>	<i>26.0</i>
No. 3	<i>"</i>		SANGAMO No. 2	<i>N/A</i>	
No. 4	<i>"</i>		SABTS SEQ.		
			CALORIMETER (SABTS)	<i>12.8</i>	<i>20.3</i>
SABTS INST.			CALORIMETER (SLOW SHUTTER)	<i>10.0</i>	<i>14.8</i>
<i>41 FINE SOLID</i>	<i>10.0</i>	<i>27.3</i>		<i>20.3</i>	<i>27.3</i>

LASER PERFORMANCE ANALYSIS, RUN VL-266

BEAM INTENSITY PROFILE

AS SEEN BY IR CAMERA VIEWING SECOND TURN FLAT

TOTAL INTENSITY

APPROX. TIME (SEC) \_\_\_\_\_

LINEAR PROFILE\*

APPROX. TIME (SEC) \_\_\_\_\_

COULD NOT RETRIEVE DATA  
FROM SANGAM RECORDER

LIE BERGERSON

BEAM DIAGNOSTICS ENGINEER

LASER PERFORMANCE ANALYSIS - RUN NUMBER VL 1-267

### ESTIMATED POWER VS. TIME

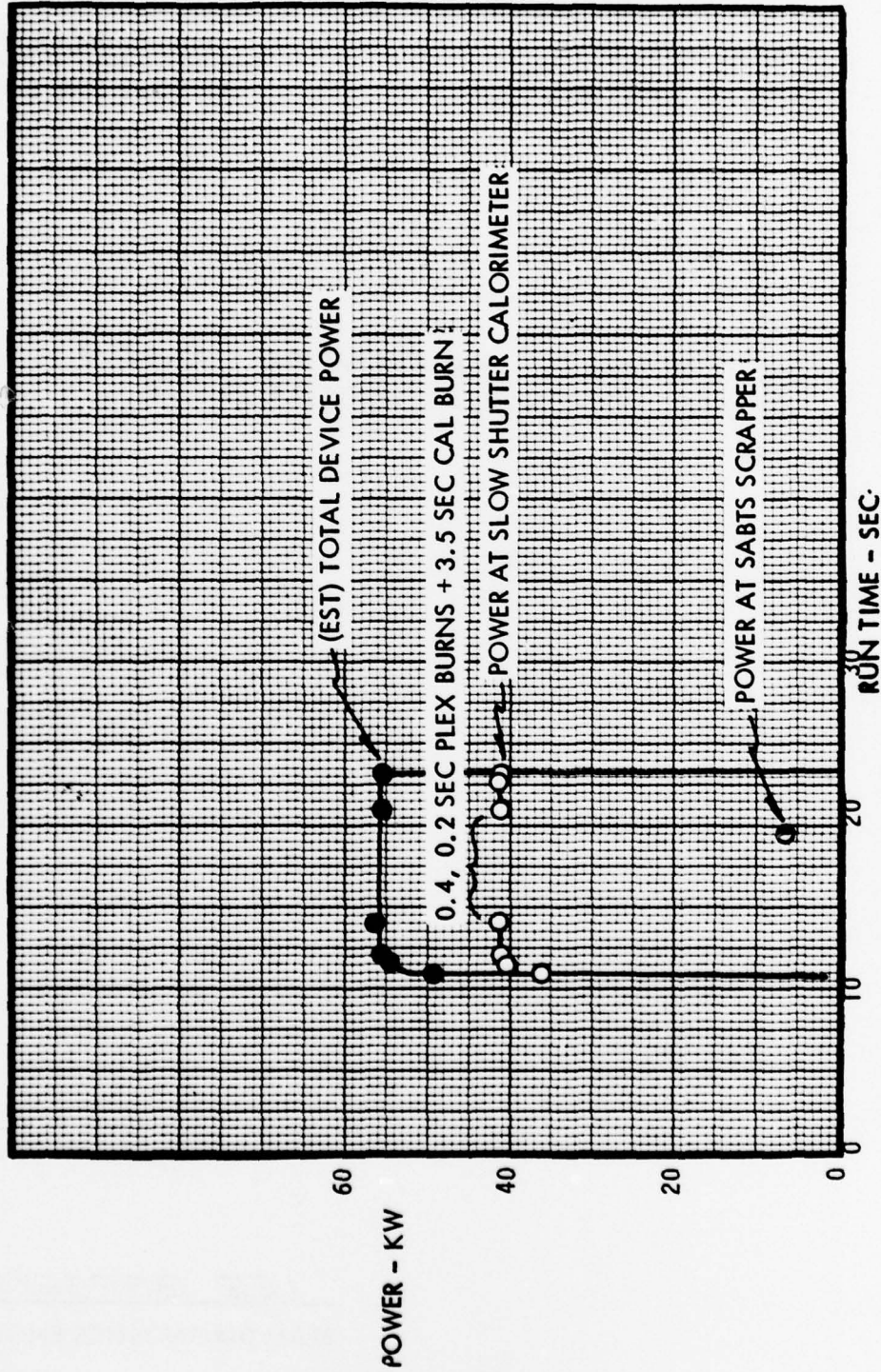

REMARKS:

PREPARED BY: J. SINGS  
Z-8-77

# PLANNED TIME LINES AND QUICK LOOK DATA SHEET

QUICK LOOK TEST DATA			
RUN NO. VLI-267	TEST PLAN SAET 4	DATE 2-8-77	TIME 2338
D2 FIRE VALVE OPEN (SEC) 10.4	D2 FIRE VALVE CLOSED (SEC) 23.2	LASING DURATION (SEC) 12.8	TOTAL COMPLETED TEST POSITIONS 3
PLANNED TEST NO. R76		AS OF	DATE 2-7-77
TIME LINES		REVISION 0770	

EXPERIMENTER	PLANNED LINEAR MAGNIFICATION	PLANNED PEAK PWR DENSITY	CONFIGURATION	ACTUAL										
				REFLECTIVE	TRANSMISSIVE	TIME SLICE	EST. PWR. AT TARGET	TOTAL POWER	ACTUAL SPOT DIAMETER	COMMENTS				
D. MULLEN	45 KW/CM <sup>2</sup>	PLANNED	ACTUAL	EXPOSURE TIME (SEC)	TRANSIT TIME (POST EXPOSURE)	TIME FROM F <sub>2</sub>	TIME SLICE	EST. PWR. AT TARGET	TOTAL POWER	ACTUAL SPOT DIAMETER	COMMENTS			
				1	2	3	4	5	6					
				LONE CAL	PLEXI 1	PLEXI 2	TOT ABS CAL	LONE CAL						
				4.0	0.4	0.2	3.5	3.0	10.0	14.0		57.5		
									19.0	15.5				
									16.8	20.3	22.7	57.5		

ITEM	START (SEC)	STOP (SEC)	ITEM	START (SEC)	STOP (SEC)
TV CAMERA No. 1	DN		O-GRAPH	N/A	N/A
No. 2	"		SANGAMO No. 1	6.0	22.7
No. 3	"		SANGAMO No. 2	N/A	
No. 4	"		SABTS SEQ.		
SABTS INST.	10.0	23.3	CALORIMETER (SABTS)	16.6	20.3
			CALORIMETER (SLOW SHUTTER)	10.0	14.0
			"	20.3	23.5

LASER PERFORMANCE ANALYSIS, RUN VLI-267

BEAM INTENSITY PROFILE

AS SEEN BY IR CAMERA VIEWING SECOND TURN FLAT

TOTAL INTENSITY

APPROX. TIME (SEC) \_\_\_\_\_

LINEAR PROFILE\*

APPROX. TIME (SEC) \_\_\_\_\_

COULD NOT RETRIEVE DATA  
FROM SECOND TURN FLAT

LEE BERGERSON

BEAM DIAGNOSTICS ENGINEER

LASER PERFORMANCE ANALYSIS - RUN NUMBER VL 1-268

### ESTIMATED POWER VS. TIME

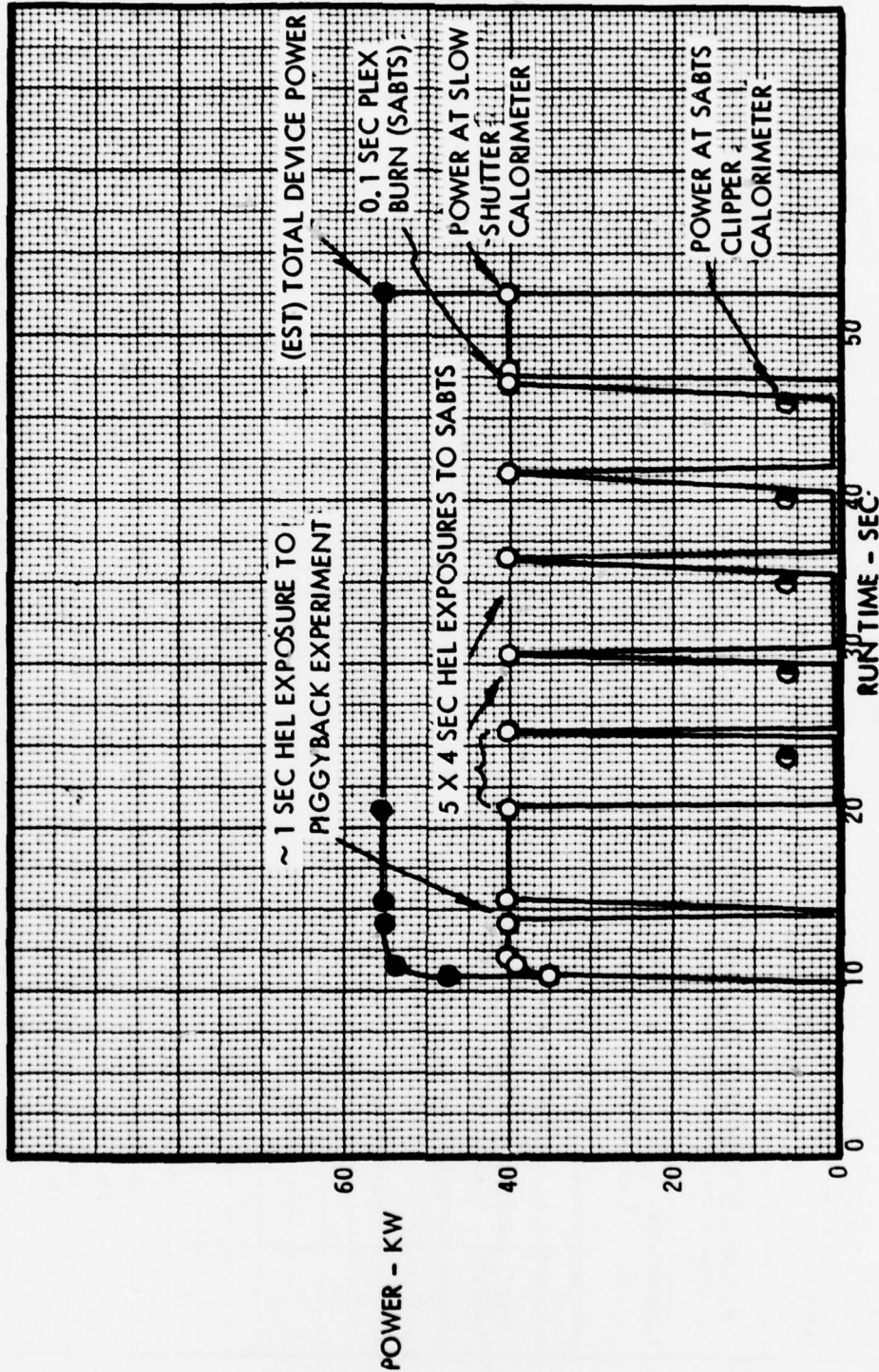

REMARKS:

PREPARED BY:

V. S. NG  
2-10-77

# PLANNED TIME LINES AND QUICK LOOK DATA SHEET

QUICK LOOK TEST DATA			
RUN NO.	TEST PLAN	DATE	TIME
11-268	SABTS	2-9-77	2111
D2 FIRE VALVE OPEN (SEC)	D2 FIRE VALVE CLOSED (SEC)	LASING DURATION (SEC)	TOTAL COMPLETED TEST POSITIONS
104	52.4	42.0	7
PLANNED TEST NO. 0676/041 TIME LINES			PLANNED TOTAL PWR. 5.4
AS OF DATE 2-9-77 REVISION 1			

EXPERIMENTER <b>C. MULLEN</b>	PLANNED LINEAR MAGNIFICATION 1.7	CONFIGURATION <input checked="" type="checkbox"/> REFLECTIVE <input type="checkbox"/> TRANSMISSIVE
	PLANNED PEAK PWR DENSITY 10 KW/CM <sup>2</sup>	

TEST POSITION	SPECIMEN NO.	COATING DESIGN	PLANNED				ACTUAL				COMMENTS
			EXPOSURE TIME (SEC)	TRANSIT TIME (POST EXPOSURE)	TIME FROM F <sub>2</sub>	TIME SLICE	EST. PWR. AT TARGET	TOTAL POWER	ACTUAL SPOT DIAMETER		
1	111	PLX1	1.0	6.50	14.00						
2		PE	4.0	1.10	21.50						
3		DNF	4.0	1.10	26.00						
4		DNF	4.0	1.10	31.00						
5		DNF	4.0	1.10	36.00						
6		DNF	4.0	1.10	41.00						
		DNF	4.0	1.10	47.00						
		DNF	4.0	1.10	47.11						

ITEM	START (SEC)	STOP (SEC)	ITEM	START (SEC)	STOP (SEC)
T1 CAMERA No. 1	0.1		O-GRAPH	MCA	MCA
No. 2	"		SANGAMO No. 1	N 1/1	
No. 3	"		SANGAMO No. 2	N 1/1	
No. 4	"		SABTS SEQ.	21.5	47.1
SAFETY SIGNAL	11.0	18.00	CALORIMETER (SABTS)	21.5	47.1
SABTS INSTR.			CALORIMETER (SLOW SHUTTER)	10.0	14.0
THE NEW ORLEANS	10.0	52.6		15.0	21.5
THE NEW ORLEANS	10.0	52.6		47.1	52.6

LASER PERFORMANCE ANALYSIS, RUN VLI-268

BEAM INTENSITY PROFILE

AS SEEN BY IR CAMERA VIEWING SECOND TURV FLAT

TOTAL INTENSITY

APPROX. TIME (SEC) \_\_\_\_\_

LINEAR PROFILE\*

APPROX. TIME (SEC) \_\_\_\_\_

*SANGAMO RECORDER NOT  
OPERATIVE*

LASER PERFORMANCE ANALYSIS - RUN NUMBER VL 1-269

### ESTIMATED POWER VS. TIME

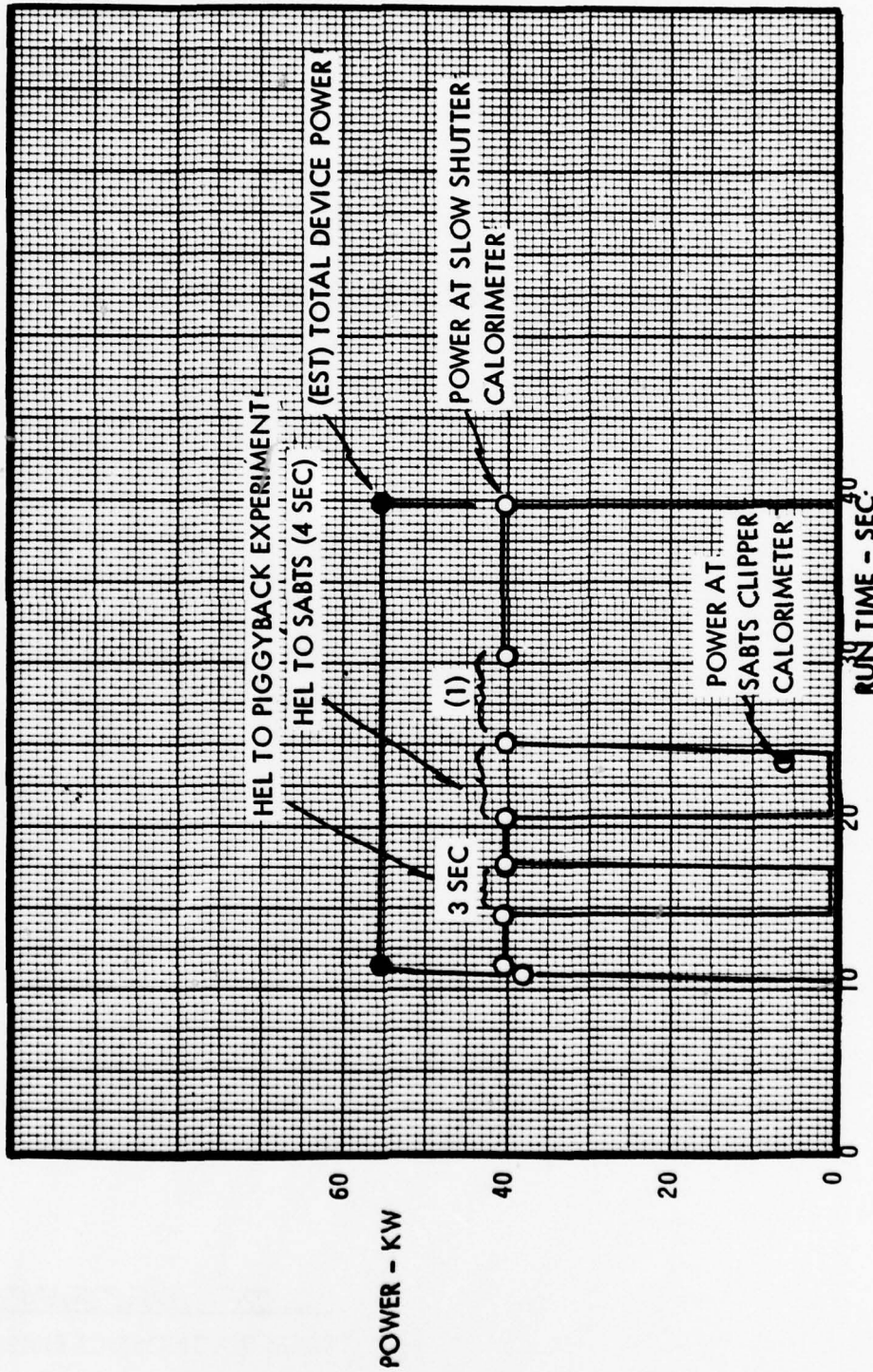

REMARKS: (1) CAROUSEL INDEXED AFTER 1<sup>st</sup> SAMPLE BURNED THROUGH.

PREPARED BY:

*J. SINGS*  
2-10-77

**PLANNED TIME LINES AND QUICK LOOK DATA SHEET**

RUIN NO.	TEST PLAN	DATE	TIME
LI-267	SDESTS	2-9-77	2307
D2 FIRE VALVE OPEN (SEC)	D2 FIRE VALVE CLOSED (SEC)	LASING DURATION (SEC)	TOTAL COMPLETED TEST POSITIONS
10.4	39.6	29.2	5
			PLANNED TOTAL PWR. 59

PLANNED TEST NO. 0E1/0A2 TIME LINES AS OF DATE 2-9-77 REVISION 1/1

EXPERIMENTER	PLANNED LINEAR MAGNIFICATION	CONFIGURATION
D. MULLEN	1.7	<input type="checkbox"/> REFLECTIVE <input checked="" type="checkbox"/> TRANSMISSIVE
	PLANNED PEAK PWR DENSITY	
	10 KW/CM <sup>2</sup>	

PLANNED				ACTUAL				COMMENTS	
TEST POSITION	SPECIMEN NO.	COATING DESIGN	EXPOSURE TIME (SEC)	TRANSIT TIME (POST EXPOSURE)	TIME FROM t <sub>2</sub>	TIME SLICE	FST. PWR. AT TARGET		TOTAL POWER
1			3.0	4.5	14.00	13.5		56.8	
2			4.0	1.10	21.50	20.7		57.2	
3	*	PE	4.0	1.10	26.00				
4		DOF	4.0	1.10	31.70				
5		DOF	4.0	1.10	36.80	36.0		57.0	
6	*	PE	4.0	1.10	41.90				
		PE	4.11	1.10	47.00				
		PE	4.11	1.10	47.11				
NOTE: TEST ABORTED WHEN CALORIMETER CAUGHT FIRE									

ITEM	START (SEC)	STOP (SEC)	ITEM	START (SEC)	STOP (SEC)
TV CAMERA No. 1	ON		O-GRAPH	OFF	OFF
No. 2	"		SANGAMO No. 1	ON	ON
No. 3	"		SANGAMO No. 2	ON	ON
No. 4	"		SABTS SEQ.	21.5	47.1
WARD TUNNEL	11.0	18.00	CALORIMETER (SABTS)	21.5	47.1
SABTS INST.		32.6	CALORIMETER (SLOW SHUTTER)	15.0	21.5
HI TOWN SQUAD	10.0			47.1	52.6
EFFECTS WORKUP	END OF 1				

LASER PERFORMANCE ANALYSIS, RUN VLI-269

**BEAM INTENSITY PROFILE**

AS SEEN BY IR CAMERA VIEWING SECOND TURN FLAT

TOTAL INTENSITY  
APPROX. TIME (SEC) 20

LINEAR PROFILE\*  
APPROX. TIME (SEC) 20

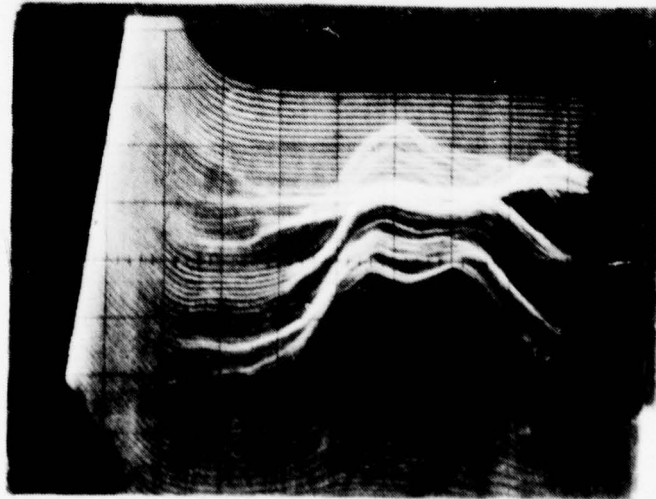
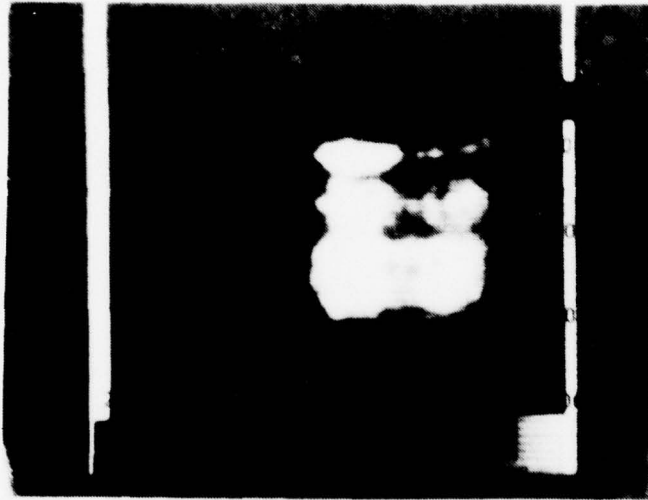

LEE BERGERSON  
BEAM DIAGNOSTICS ENGINEER

LASER PERFORMANCE ANALYSIS - RUN NUMBER VL 1-270

**ESTIMATED POWER VS. TIME**

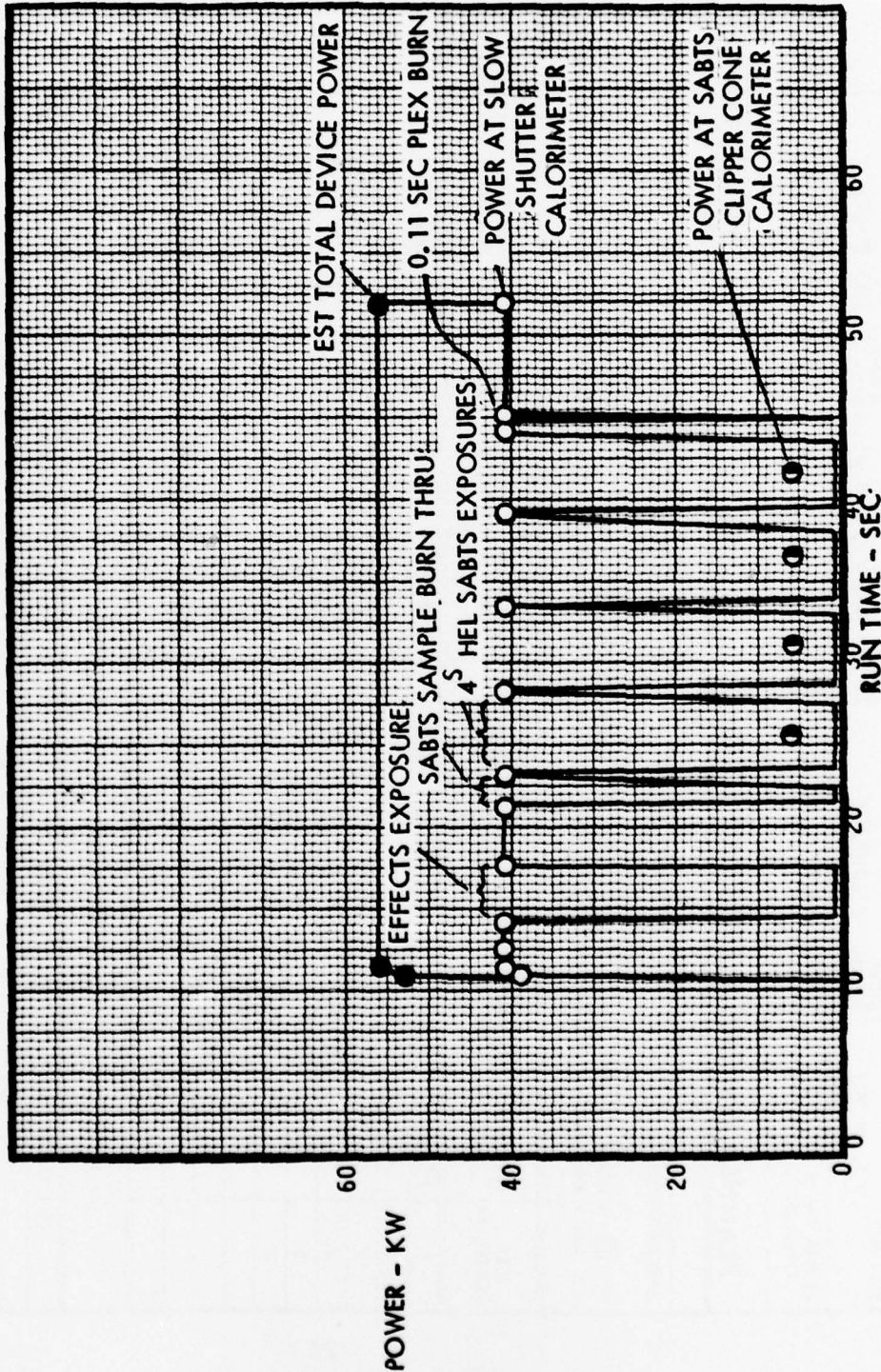

REMARKS: \_\_\_\_\_

PREPARED BY:

J. SINGS  
2-11-77

**PLANNED TIME LINES AND QUICK LOOK DATA SHEET**

QUICK LOOK TEST DATA			
RUN NO. <b>VLI-270</b>	TEST PLAN <b>SABTS</b>	DATE <b>2-10-77</b>	TIME <b>1935</b>
D2 FIRE VALVE OPEN (SEC) <b>10.4</b>	D2 FIRE VALVE CLOSED (SEC) <b>51.9</b>	LASING DURATION (SEC) <b>41.5</b>	TOTAL COMPLETED TEST POSITIONS <b>7</b>
PLANNED TEST NO. <b>0E17/0A3</b> TIME LINES			PLANNED TOTAL PWR. <b>59</b>
AS OF			DATE <b>2-10-77</b> REVISION <b>DRIG</b>

EXPERIMENTER <b>D. MULLEN</b>	PLANNED LINEAR MAGNIFICATION <b>1.7</b>	CONFIGURATION <input checked="" type="checkbox"/> REFLECTIVE <input type="checkbox"/> TRANSMISSIVE
	PLANNED PEAK PWR DENSITY <b>10KW/CM<sup>2</sup></b>	

TEST POSITION	SPECIMEN NO.	COATING DESIGN	PLANNED				ACTUAL				COMMENTS
			EXPOSURE TIME (SEC)	TRANSIT TIME (POST EXPOSURE)	TIME FROM F <sub>2</sub>	TIME SLICE	EST. PWR. AT TARGET	TOTAL POWER	ACTUAL SPOT DIAMETER		
1	PLEXI		3.0	4.5	14.00	13.0		57.2			
2											
3	* PE		4.0	1.10	21.50	20.7		56.8			
4	DOF		4.0	1.10	26.00						
5	DOF		4.0	1.10	31.70						
6	HOUSE		4.0	1.10	36.80						
	* HOUSE		4.0	1.10	41.90						
	PLEXI		0.11		47.00						
					47.11	50.9		56.9			

ITEM	START (SEC)	STOP (SEC)	ITEM	START (SEC)	STOP (SEC)
TV CAMERA No. 1	ON		O-GRAPH	MAN.	MAN.
No. 2	"		SANGAMO No. 1	6.0	54.0
No. 3	"		SANGAMO No. 2	N/A	
No. 4	"		SABTS SEQ.	21.5	47.1
WIND TUNNEL	11.0	18.00	CALORIMETER (SABTS)	21.5	47.1
SABTS INST.			CALORIMETER (SLOW SHUTTER)	10.0	14.0
HI FLOW SOLENOID	10.0	52.6	"	15.0	21.5
EFFECTS MIRROR	END OF 1		"	47.1	52.6
* PROFILER			"	"	"

LASER PERFORMANCE ANALYSIS, RUN VL1-270

**BEAM INTENSITY PROFILE**

AS SEEN BY IR CAMERA VIEWING SECOND TURN FLAT

TOTAL INTENSITY

APPROX. TIME (SEC) 20

LINEAR PROFILE\*

APPROX. TIME (SEC) 20

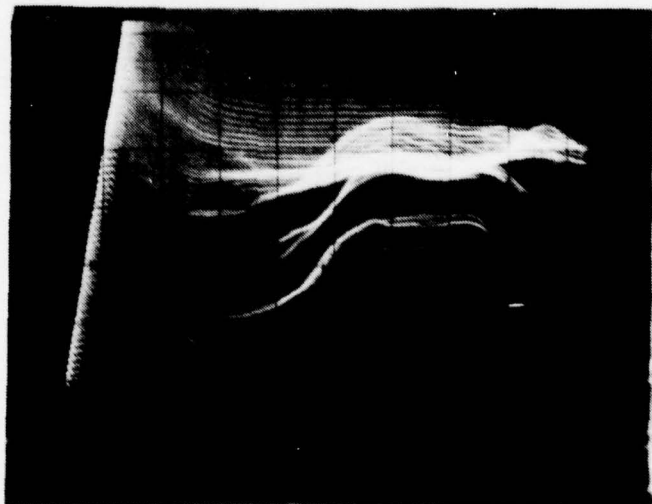
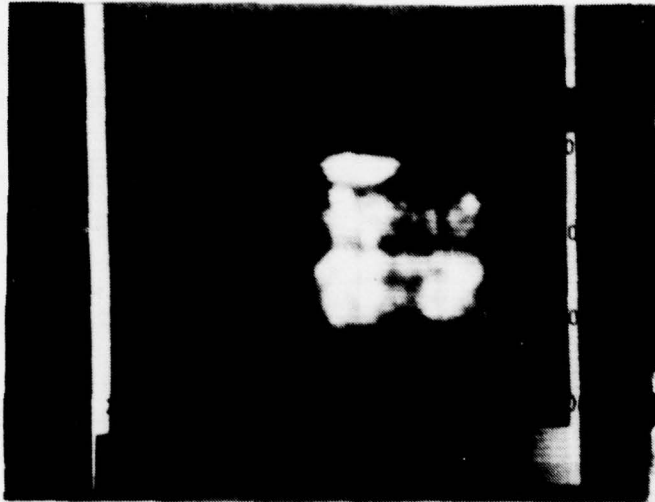

LEE BERGERSON

BEAM DIAGNOSTICS ENGINEER

LASER PERFORMANCE ANALYSIS - RUN NUMBER VL 1-271

**ESTIMATED POWER VS. TIME**

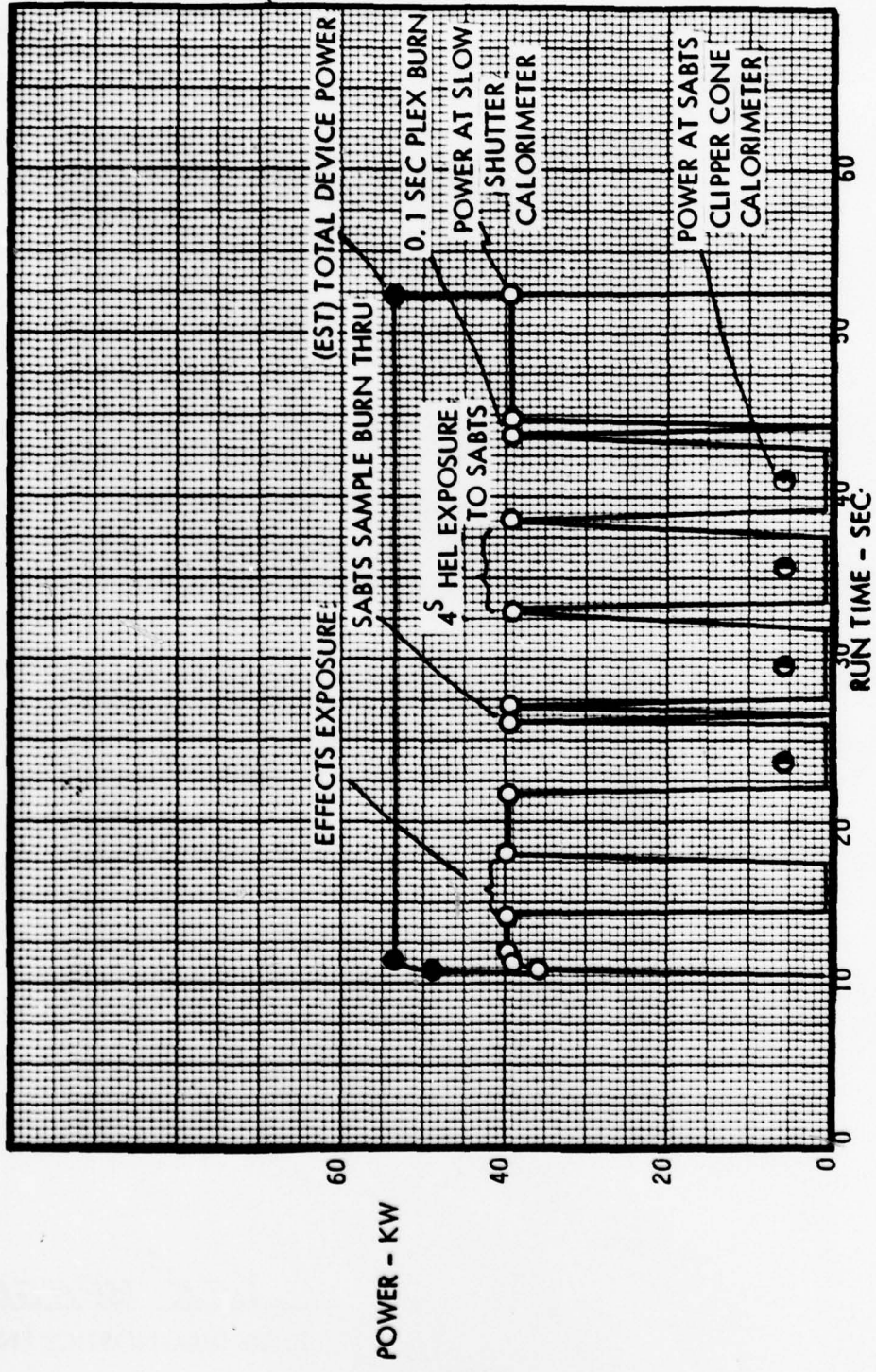

REMARKS: \_\_\_\_\_

PREPARED BY: J. SINGS  
2-11-77

# PLANNED TIME LINES AND QUICK LOOK DATA SHEET

QUICK LOOK TEST DATA			
RUN NO. <b>VLI-271</b>	TEST PLAN <b>SABTS</b>	DATE <b>2-10-77</b>	TIME <b>2209</b>
D2 FIRE VALVE OPEN (SEC) <b>10.4</b>	D2 FIRE VALVE CLOSED (SEC) <b>52.4</b>	LASING DURATION (SEC) <b>42.0</b>	TOTAL COMPLETED TEST POSITIONS <b>7</b>
PLANNED TEST NO. <b>0E2/RCI</b> TIME LINES			PLANNED TOTAL PWR. <b>59</b>
AS OF <b>DATE 2-10-77</b> REVISION <b>A</b>			

EXPERIMENTER <b>D. MULLEN</b>	PLANNED LINEAR MAGNIFICATION <b>1.7</b>	CONFIGURATION <input type="checkbox"/> REFLECTIVE <input checked="" type="checkbox"/> TRANSMISSIVE
	PLANNED PEAK PWR DENSITY <b>10 KW/CM<sup>2</sup></b>	

PLANNED		ACTUAL								
TEST POSITION	SPECIMEN NO.	COATING DESIGN	EXPOSURE TIME (SEC)	TRANSIT TIME (POST EXPOSURE)	TIME FROM F <sub>2</sub>	TIME SLICE	EST. PWR. AT TARGET	TOTAL POWER	ACTUAL SPOT DIAMETER	COMMENTS
1	RCI		3.0	4.5	14.00	13.5		55.8		
2										
3	* DDF		4.0	1.10	21.50	21.2		55.5		
4	PE		4.0	1.10	26.60					
5	DDF		4.0	1.10	31.70					
6	* PETTY		4.0	1.10	36.80					
	PETTY		4.0	1.10	41.90					
	FLEXI		0.11		47.00					
					47.11	51.9		55.6		

ITEM	START (SEC)	STOP (SEC)	ITEM	START (SEC)	STOP (SEC)
TV CAMERA No. 1	ON		O-GRAPH	MAN.	MAN.
No. 2	"		SANGAMO No. 1	6.0	54.0
No. 3	"		SANGAMO No. 2	N/A	
No. 4	"		SABTS SEQ.	21.5	47.1
WIND TUNNEL	11.0	18.00	CALORIMETER (SABTS)	21.5	47.1
SABTS INST.			CALORIMETER (SLOW SHUTTER)	10.0	14.0
H1 FLOW SOLENOID	10.0	52.6	"	11	15.0
EFFELTS MIRROR	END OF 1		"	11	47.1
* PROFILER			"	11	52.6

LASER PERFORMANCE ANALYSIS, RUN VL1-211

**BEAM INTENSITY PROFILE**

AS SEEN BY IR CAMERA VIEWING FIRST TURN FLAT

TOTAL INTENSITY  
APPROX. TIME (SEC) 20

LINEAR PROFILE\*  
APPROX. TIME (SEC) 20

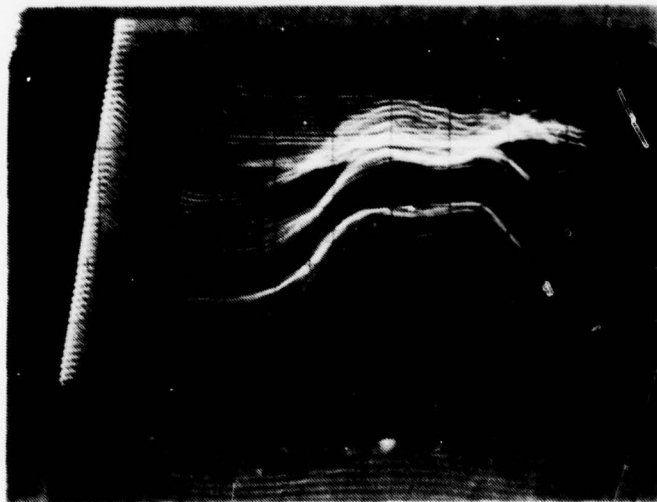
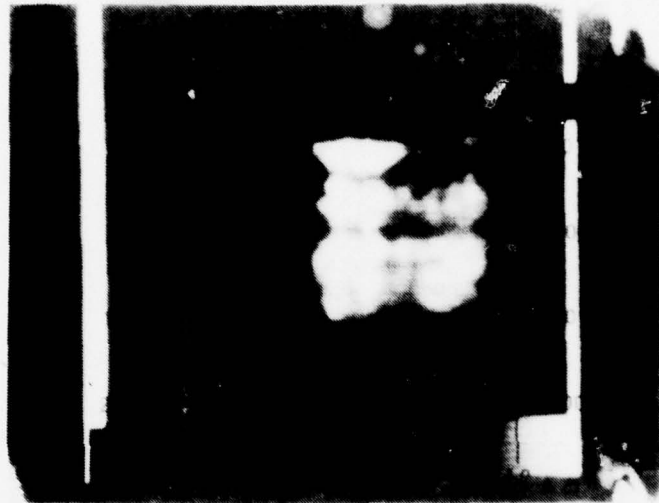

LASER PERFORMANCE ANALYSIS - RUN NUMBER VL 1-272

**ESTIMATED POWER VS. TIME**

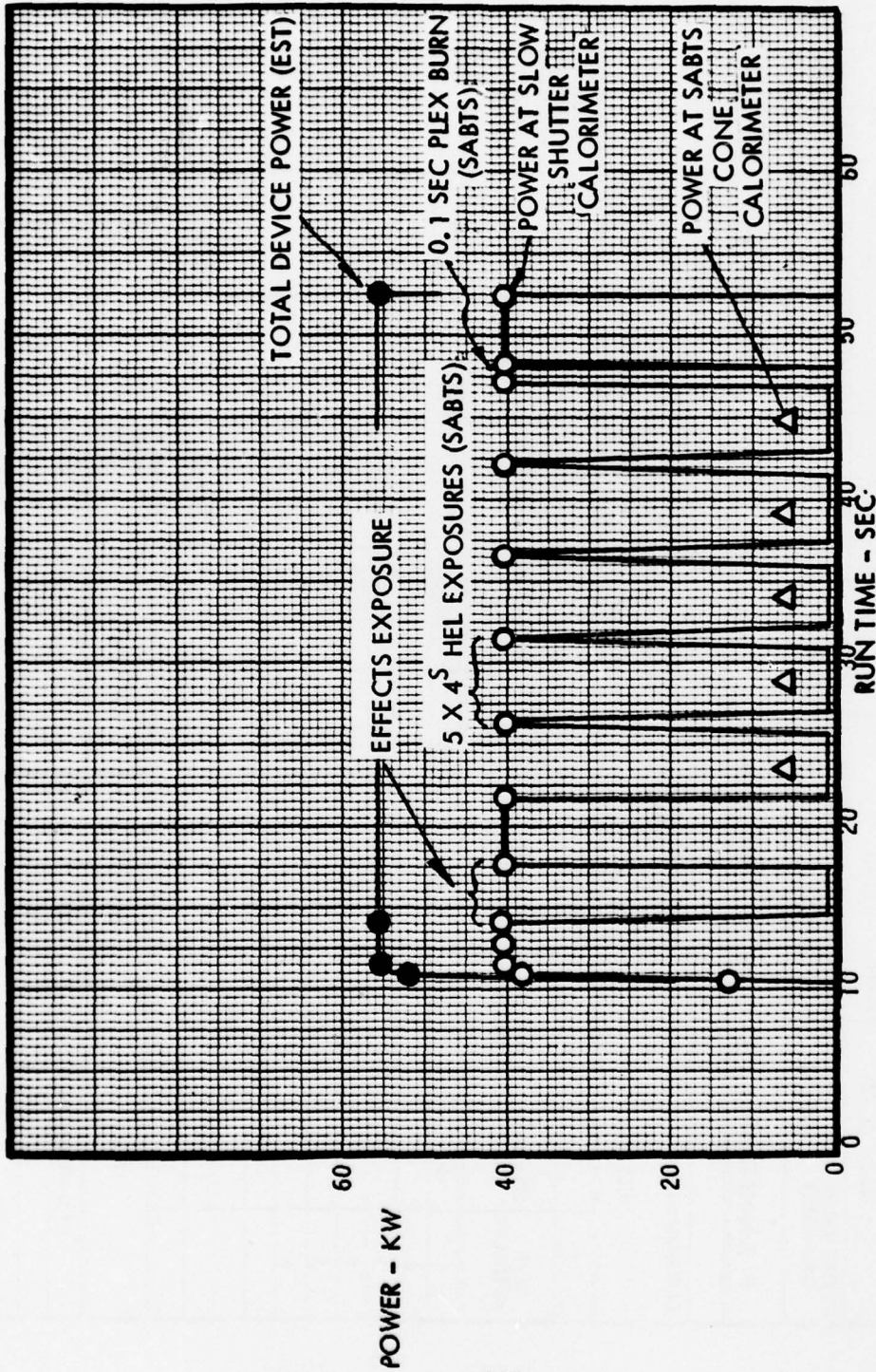

REMARKS:

PREPARED BY: J. Sinnes  
2-11-77

4

# PLANNED TIME LINES AND QUICK LOOK DATA SHEET

## QUICK LOOK TEST DATA

RUN NO.	VL1- 272	TEST PLAN	SABTS	DATE	TIME
D2 FIRE VALVE OPEN (SEC)	10.4	D2 FIRE VALVE CLOSED (SEC)	52.4	2-11-77	1920
			LASING DURATION (SEC)	42.0	TOTAL COMPLETED TEST POSITIONS
					7
					PLANNED TOTAL PWR. 59

**PLANNED TEST NO. 0123/M1 TIME LINES AS OF DATE 2-11-77 REVISION A**

EXPERIMENTER	PLANNED LINEAR MAGNIFICATION	CONFIGURATION
D. MULLEN	1.7	<input type="checkbox"/> REFLECTIVE
	PLANNED PEAK PWR DENSITY	<input checked="" type="checkbox"/> TRANSMISSIVE
	10 kw/cm <sup>2</sup>	

PLANNED						ACTUAL				
TEST POSITION	SPECIMEN NO.	COATING DESIGN	EXPOSURE TIME (SEC)	TRANSIT TIME (POST EXPOSURE)	TIME FROM F <sub>2</sub>	TIME SLICE	EST. PWR. AT TARGET	TOTAL POWER	ACTUAL SPOT DIAMETER	COMMENTS
1	M1		3.0	4.5	14.00	14.0		57		
2										
3	*	DOF	4.0	1.10	21.50	20.7		57		
4		PIE	4.0	1.10	26.60					
5		DOF	4.0	1.10	31.70					
6		PEITY	4.0	1.10	36.80					
	*	PEITY	4.0	1.10	41.90					
		PEEX1	.11		47.00					
					47.11	51.4		56.5		

ITEM	START (SEC)	STOP (SEC)	ITEM	START (SEC)	STOP (SEC)
TV CAMERA No. 1	ON		O-GRAPH	MAN.	MAN.
No. 2	ON		SANGAMO No. 1	6.0	54
No. 3	ON		SANGAMO No. 2	N/A	
No. 4	ON		SABTS SEQ.	21.5	47.1
WIND TUNNEL	11.0	18.00	CALORIMETER (SABTS)	21.5	47.1
SABTS INST.			CALORIMETER (SLOW SHUTTER)	10.0	14.0
HI FLOW SOLENOID	10.0	52.6		15.0	21.5
EFFECT MIRROR	END OF 1			47.1	52.6

\*Profiler

LASER PERFORMANCE ANALYSIS, RUN VLI 272

**BEAM INTENSITY PROFILE**

AS SEEN BY IR CAMERA VIEWING FIRST TURN FLAT

TOTAL INTENSITY  
APPROX. TIME (SEC) 20

LINEAR PROFILE\*  
APPROX. TIME (SEC) 20

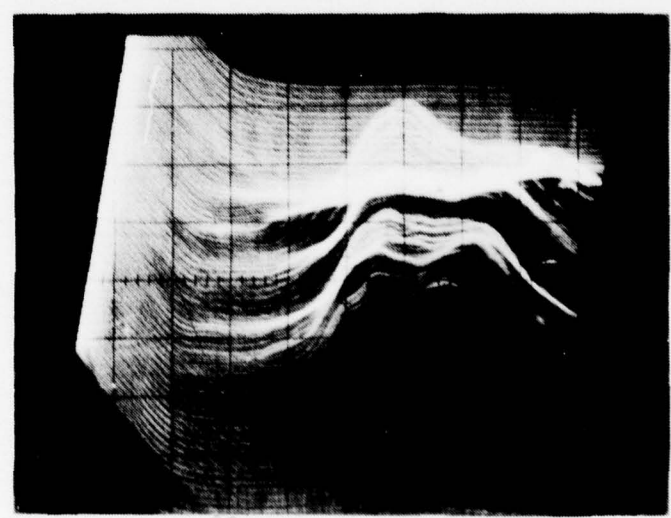
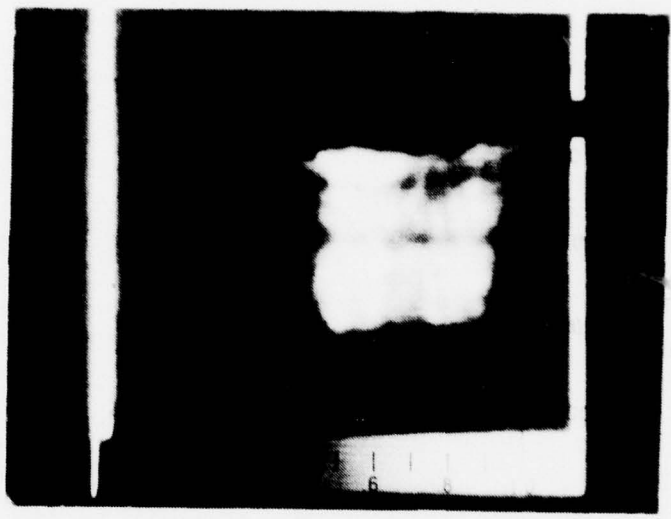

LEE BERGERSON

135 BEAM DIAGNOSTICS ENGINEER

LASER PERFORMANCE ANALYSIS - RUN NUMBER VL 1-273  
**ESTIMATED POWER VS. TIME**

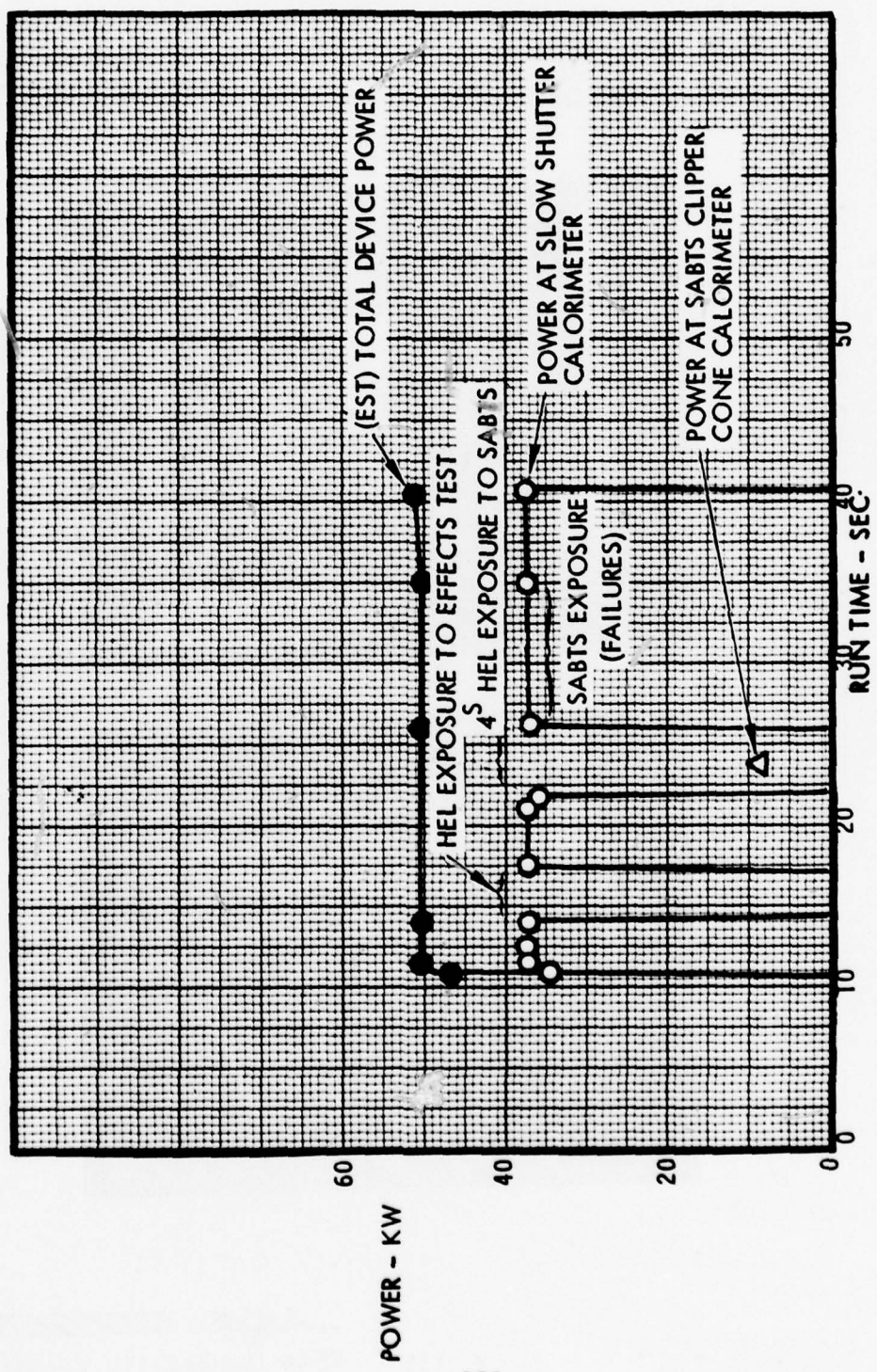

REMARKS:

PREPARED BY:

J. SINGH  
2-16-77

# PLANNED TIME LINES AND QUICK LOOK DATA SHEET

QUICK LOOK TEST DATA			
RUN NO.	TEST PLAN	DATE	TIME
VLI-273		2-15-77	2113
D2 FIRE VALVE OPEN (SEC)	10.4	LASING DURATION (SEC)	30.3
D2 FIRE VALVE CLOSED (SEC)	40.7	TOTAL COMPLETED TEST POSITIONS	5
			PLANNED TOTAL PWR. 59

**PLANNED TEST NO. 0E4 / 1st TIME LINES AS OF DATE 2-14-77 REVISION A**

EXPERIMENTER	PLANNED LINEAR MAGNIFICATION	CONFIGURATION
D. MULLEN	1.7	<input type="checkbox"/> REFLECTIVE <input checked="" type="checkbox"/> TRANSMISSIVE
	PLANNED PEAK PWR DENSITY 10 kw/cm <sup>2</sup>	

TEST POSITION	SPECIMEN NO.	COATING DESIGN	EXPOSURE TIME (SEC)	TRANSIT TIME (POST EXPOSURE)	TIME FROM F <sub>2</sub>	TIME SLICE	EST. PWR. AT TARGET	TOTAL POWER	ACTUAL SPOT DIAMETER	COMMENTS	
											ACTUAL
1	SCSI		3.0	4.5	14.00	13.0		53.3			
2											
3	*	DOF	4.0	1.10	21.50	20.7		53.6			
4		PE	4.0	1.10	26.60						
5		DOF	4.0	1.10	31.70						
6		PETTY	4.0	1.10	36.80						
	*	PETTY	4.0	1.10	41.90	39.6		53.9			
		PLAXI	.11		47.00						
					47.11						
<b>NOTE: TEST TERMINATED AFTER FIFTH SABTY SPECIMEN.</b>											

ITEM	START (SEC)	STOP (SEC)	ITEM	START (SEC)	STOP (SEC)
TV CAMERA No. 1	ON		O-GRAPH	MAN.	MAN.
No. 2	ON		SANGAMO No. 1	6.0	54
No. 3	ON		SANGAMO No. 2	N/A	
No. 4	ON		SABTS SEQ.	21.5	47.1
WIND TUNNEL	11.0	18.00	CALORIMETER (SABTS)	21.5	47.1
SABTS INST.			CALORIMETER (SLOW SHUTTER)	10.0	14.0
HI FLOW SOLENOID	10.0	52.6		15.0	21.5
EFFECT MIRROR	END OF 1			47.1	52.6

\*Pr. file

REF: TCR M42970

PAGE 3 OF 4

LASER PERFORMANCE ANALYSIS, RUN VLI-273

**BEAM INTENSITY PROFILE**

AS SEEN BY IR CAMERA VIEWING SECOND TURN FLAT

TOTAL INTENSITY

APPROX. TIME (SEC) 20

LINEAR PROFILE\*

APPROX. TIME (SEC) 20

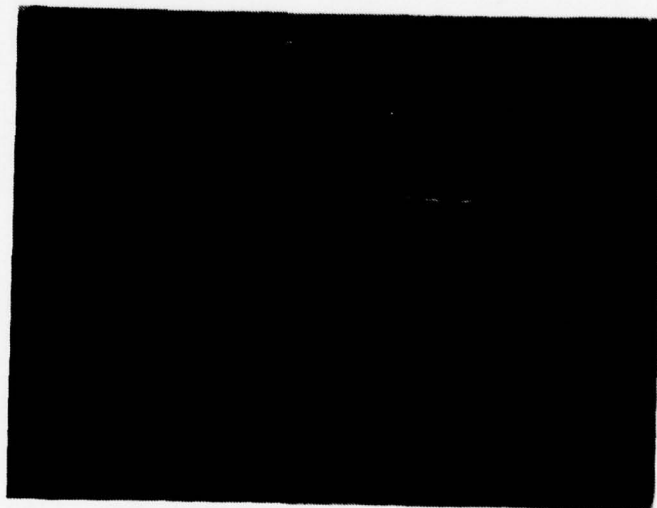
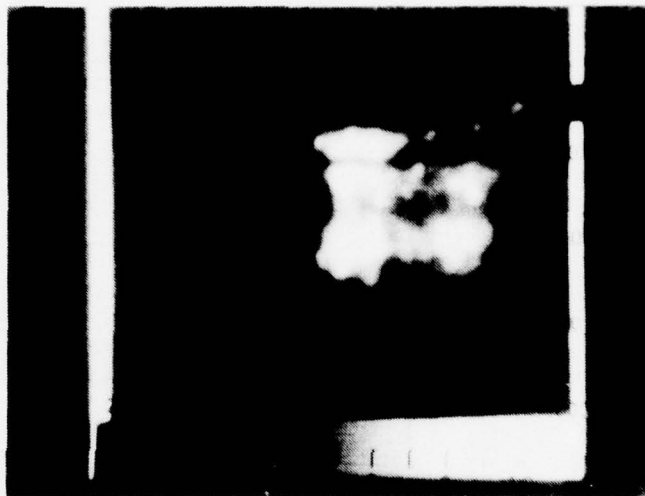

LASER PERFORMANCE ANALYSIS - RUN NUMBER VL 1-274

### ESTIMATED POWER VS. TIME

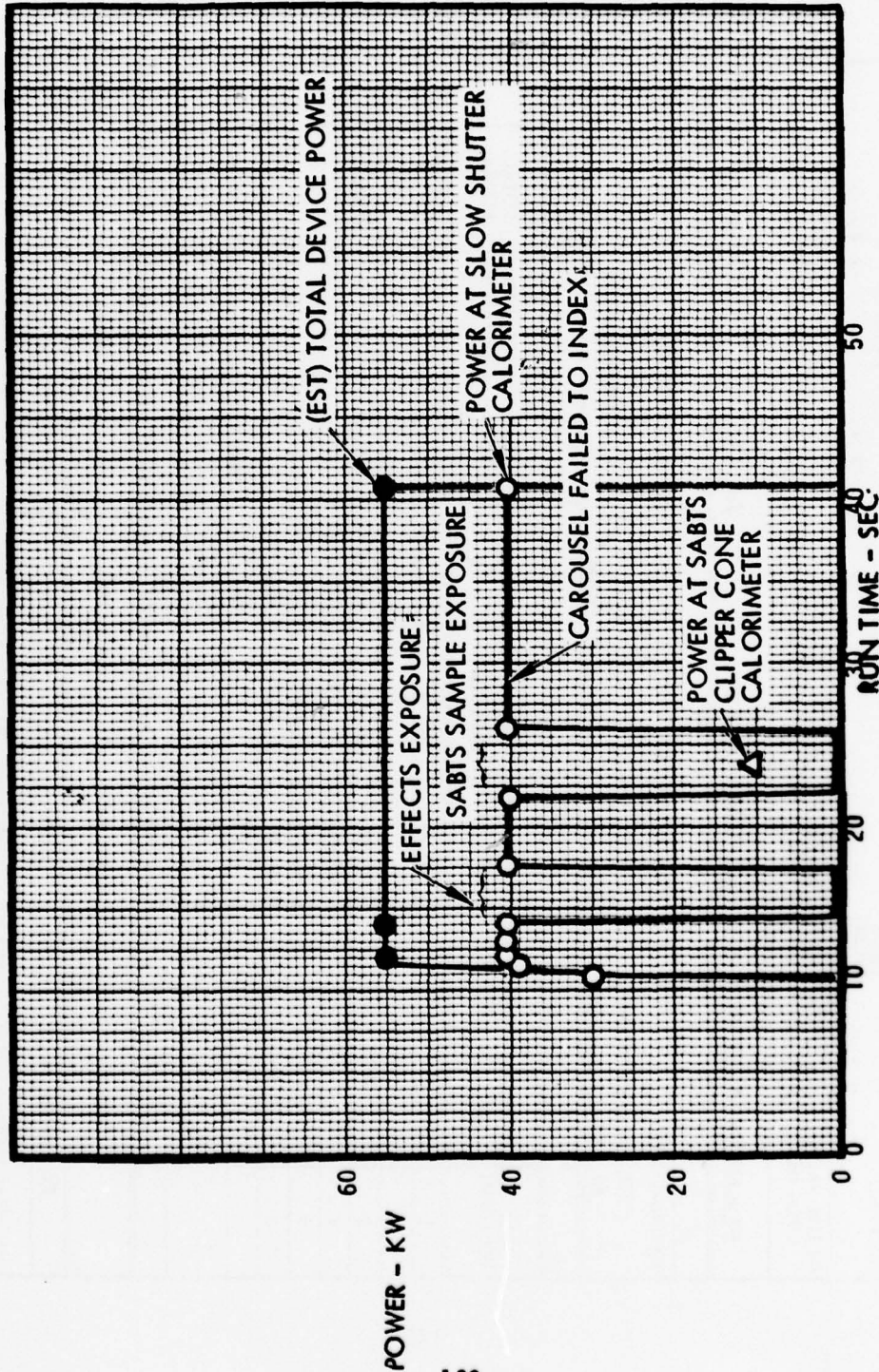

REMARKS:

PREPARED BY:

J. Sings  
2-17-77

**PLANNED TIME LINES AND QUICK LOOK DATA SHEET**

QUICK LOOK TEST DATA	
RUN NO. <b>VLI-274</b>	TEST PLAN <b>SABTS</b>
DATE <b>2-16-77</b>	TIME <b>2316</b>
D2 FIRE VALVE OPEN (SEC) <b>10.4</b>	D2 FIRE VALVE CLOSED (SEC) <b>40.7</b>
LASING DURATION (SEC) <b>30.3</b>	TOTAL COMPLETED TEST POSITIONS <b>2</b>
PLANNED TOTAL PWR. <b>59</b>	

PLANNED TEST NO. **0648** / **AS OF** DATE **2-16-77** REVISION **A**

EXPERIMENTER	PLANNED LINEAR MAGNIFICATION	PLANNED PEAK PWR DENSITY	CONFIGURATION	PLANNED		ACTUAL		COMMENTS			
				REFLECTIVE	TRANSMISSIVE	TIME FROM F <sub>2</sub>	TIME SLICE		EST. PWR. AT TARGET	TOTAL POWER	ACTUAL SPOT DIAMETER
<b>D. MULLEN</b> <b>R. DELYSEA</b>	<b>1.7</b>	<b>10 KW/CM<sup>2</sup></b>	<input checked="" type="checkbox"/> REFLECTIVE <input type="checkbox"/> TRANSMISSIVE	EXPOSURE TIME (SEC)	TRANSIT TIME (POST EXPOSURE)	TIME FROM F <sub>2</sub>	TIME SLICE	EST. PWR. AT TARGET	TOTAL POWER	ACTUAL SPOT DIAMETER	
				<b>3.0</b>	<b>4.5</b>	<b>19.00</b>	<b>14.0</b>		<b>56.9</b>		
				<b>4.0</b>	<b>1.10</b>	<b>21.50</b>	<b>20.7</b>		<b>56.6</b>		
				<b>4.0</b>	<b>1.10</b>	<b>26.60</b>					
				<b>4.0</b>	<b>1.10</b>	<b>31.70</b>					
				<b>4.0</b>	<b>1.10</b>	<b>36.80</b>					
	<b>.10</b>	<b>41.90</b>						<b>56.6</b>			
		<b>42.00</b>									

NOTE: CASSETTE DID NOT INDEX TO SECOND POSITION.

ITEM	START (SEC)	STOP (SEC)	ITEM	START (SEC)	STOP (SEC)
TV CAMERA No. 1	<b>ON</b>		O-GRAPH	<b>MAN.</b>	<b>MAN.</b>
No. 2	"		SANGAMO No. 1	<b>6.0</b>	<b>48.0</b>
No. 3	"		SANGAMO No. 2	<b>N/A</b>	
No. 4	"		SABTS SEQ.	<b>21.5</b>	<b>42.0</b>
WIND TUNNEL SABTS INST.	<b>11.0</b>	<b>18.0</b>	CALORIMETER (SABTS)	<b>21.5</b>	<b>42.0</b>
HI FLOW SOLAR WIND	<b>10.0</b>	<b>46.0</b>	CALORIMETER (SLOW SHUTTER)	<b>10.0</b>	<b>14.0</b>
EFFECTIVE MIRROR END OF 1				<b>17.0</b>	<b>21.5</b>
				<b>42.0</b>	<b>46.0</b>

\* PROFILER REF: TCR ML 21370 PAGE **3** OF **4**

LASER PERFORMANCE ANALYSIS, RUN VLI-274

BEAM INTENSITY PROFILE

AS SEEN BY IR CAMERA VIEWING SECOND TURN FLAT

TOTAL INTENSITY

APPROX. TIME (SEC) 20

LINEAR PROFILE\*

APPROX. TIME (SEC) 20

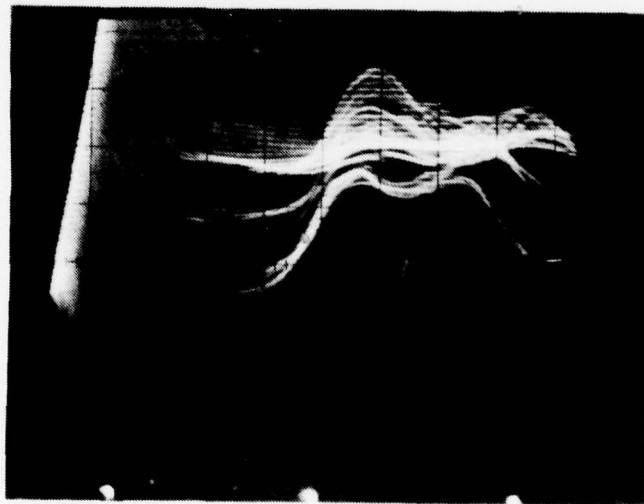
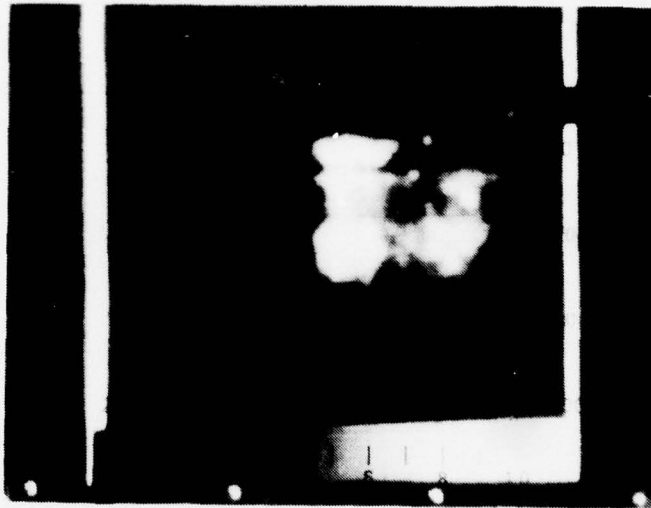

LASER PERFORMANCE ANALYSIS - RUN NUMBER VL 1-275

### ESTIMATED POWER VS. TIME

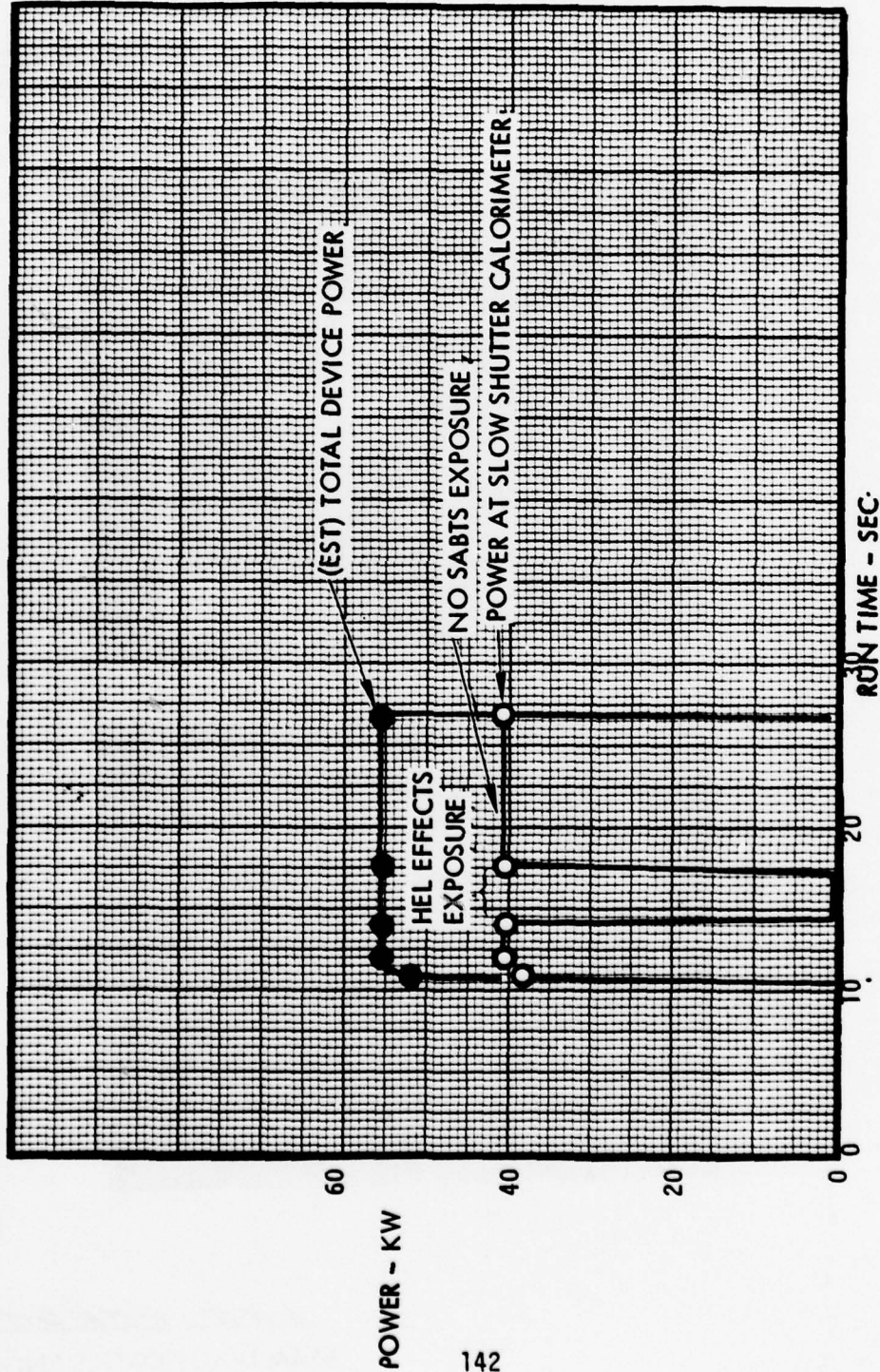

REMARKS: \_\_\_\_\_

PREPARED BY: \_\_\_\_\_

*J. SAKS*  
2-18-77

POWER - KW

**PLANNED TIME LINES AND QUICK LOOK DATA SHEET**

QUICK LOOK TEST DATA										
RUN NO.	TEST PLAN	DATE	TIME	TOTAL COMPLETED TEST POSITIONS		PLANNED TOTAL PWR.				
VLL-275	SABTS	2-17-77	2048	1		59				
D2 FIRE VALVE OPEN (SEC)	D2 FIRE VALVE CLOSED (SEC)	LASING DURATION (SEC)								
9.9	26.8	16.9								
<p align="center"><b>PLANNED TEST NO. 0619/HSC TIME LINES AS OF DATE 2-17-77 REVISION B</b></p>										
EXPERIMENTER		PLANNED LINEAR MAGNIFICATION		CONFIGURATION						
D. MULLEN		1.7		<input checked="" type="checkbox"/> REFLECTIVE <input type="checkbox"/> TRANSMISSIVE						
R. DELYPER		10 KW/CM <sup>2</sup>								
<p align="center"><b>PLANNED</b></p>										
TEST POSITION	SPECIMEN NO.	COATING DESIGN	EXPOSURE TIME (SEC)	TRANSIT TIME (POST EXPOSURE)	TIME FROM F <sub>2</sub>	TIME SLICE	EST. PWR. AT TARGET	TOTAL POWER	ACTUAL SPOT DIAMETER	COMMENTS
1	HSC2		3.0	4.5	14.00	13.0		56.8		
2										
3	# DDF		4.0	1.60	21.50	25.8		57.0		
4	DDF		4.0	1.60	27.10					
5	PE		4.0	1.60	32.70					
6	# PE		4.0	1.60	38.30					
			.10		43.90					
					44.00					
<p><b>NOTE: EFFECTS MIRROR MICRO DROPPED OUT PREVENTING SABIT TEST.</b></p>										
<p align="center"><b>ACTUAL</b></p>										
ITEM	START (SEC)	STOP (SEC)	ITEM	START (SEC)	STOP (SEC)					
TV CAMERA No. 1	ON		O-GRAPH	MAN.	MAN.					
No. 2	"		SANGAMO No. 1	6.0	50.0					
No. 3	"		SANGAMO No. 2	N/A						
No. 4	"		SABTS SEC.	21.5	44.0					
WIND TUNNEL	11.0	18.0	CALORIMETER (SABTS)	21.5	44.0					
SABTS INST.			CALORIMETER (SLOW SHUTTER)	10.0	14.0					
H.FLOW SOLARNOID	10.0	48.0	"	17.0	21.5					
EFFECTS MIRROR	END OF 1		"	44.0	48.0					
# PROFILER			"							

LASER PERFORMANCE ANALYSIS, RUN VLI-225

BEAM INTENSITY PROFILE

AS SEEN BY IR CAMERA VIEWING SECOND TURN FLAT

TOTAL INTENSITY

APPROX. TIME (SEC) 20

LINEAR PROFILE\*

APPROX. TIME (SEC) 20

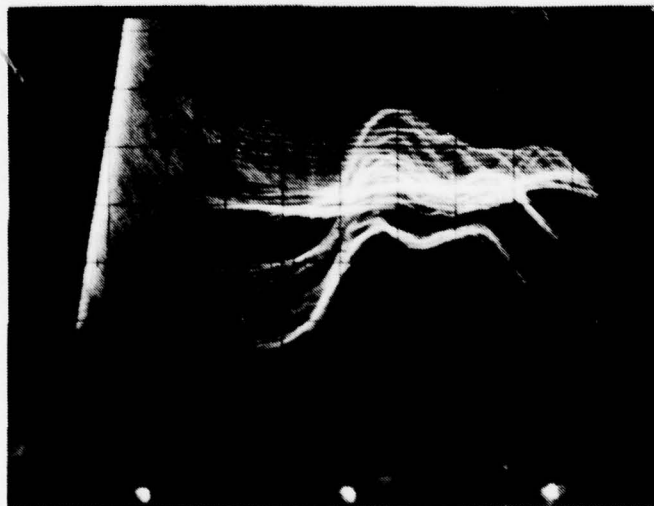
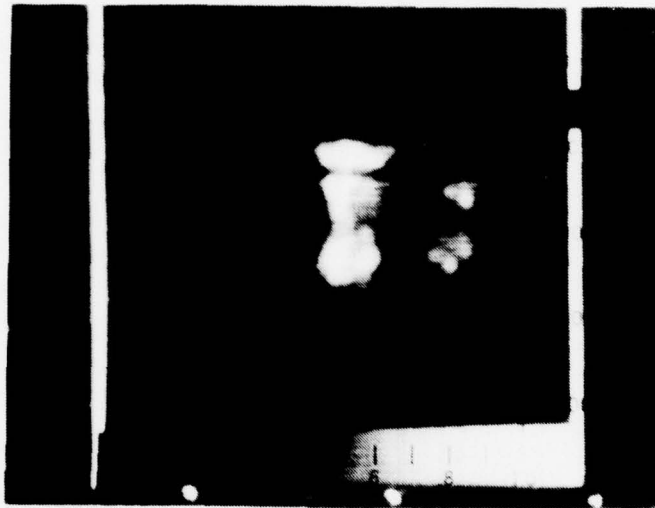

LEE BERGERSON

BEAM DIAGNOSTICS ENGINEER

LASER PERFORMANCE ANALYSIS - RUN NUMBER VL 1-276

### ESTIMATED POWER VS. TIME

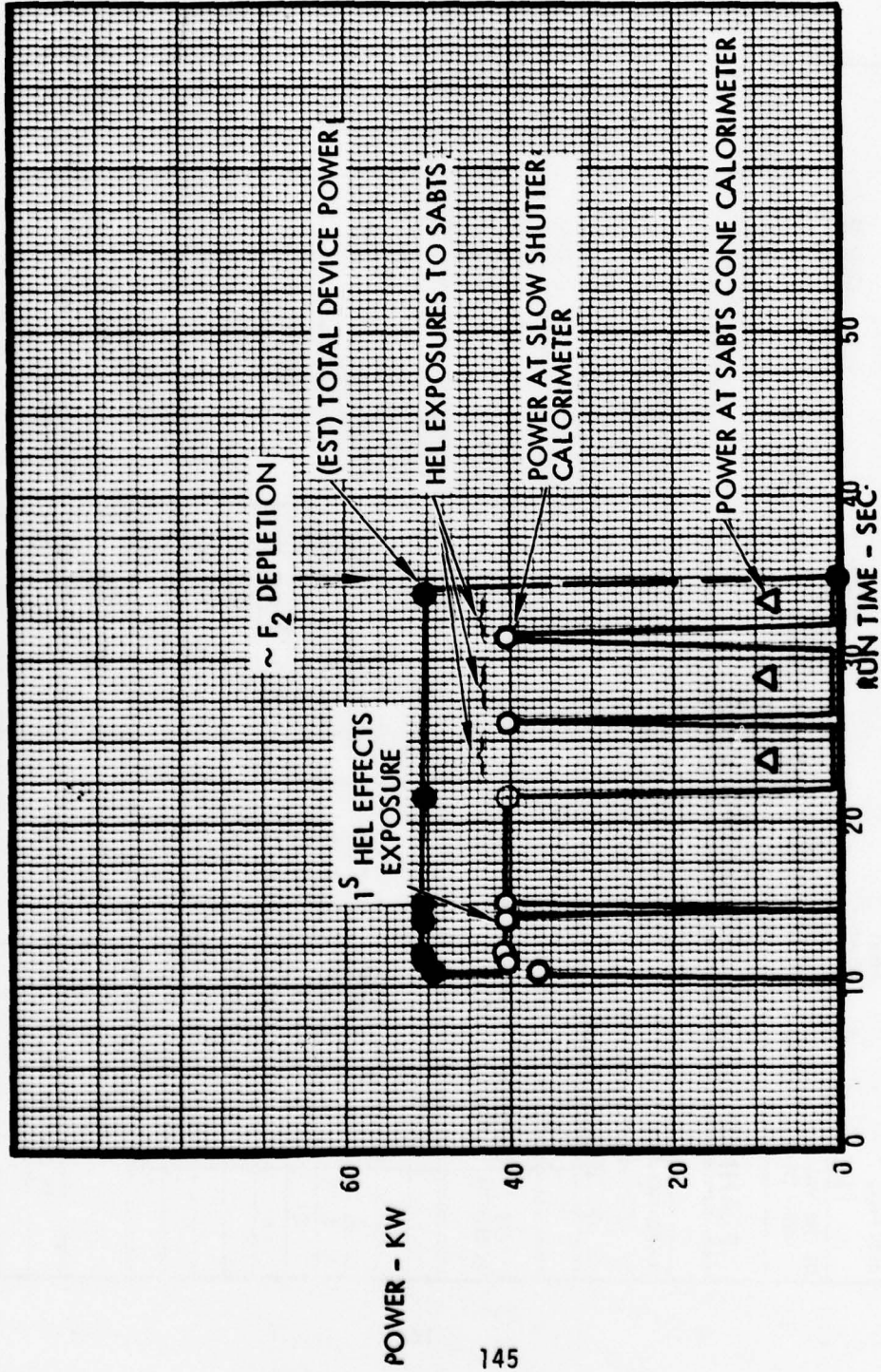

REMARKS:

PREPARED BY:

*J. Singh*

2-18-77

**PLANNED TIME LINES AND QUICK LOOK DATA SHEET**

QUICK LOOK TEST DATA	
TEST PLAN	DATE
2-17-77	2221
D2 FIRE VALVE CLOSED (SEC)	TOTAL COMPLETED TEST POSITIONS
35.0	3
D2 FIRE VALVE OPEN (SEC)	PLANNED TOTAL PWR.
10.4	59
PLANNED TEST NO. 0E190A4 TIME LINES AS OF DATE 2-17-77 REVISION A	

EXPERIMENTER	PLANNED LINEAR MAGNIFICATION	CONFIGURATION
D. MULLEN	1.7	<input checked="" type="checkbox"/> REFLECTIVE
R. DELSER	10 MW/CM <sup>2</sup>	<input type="checkbox"/> TRANSMISSIVE

TEST POSITION	SPECIMEN NO.	COATING DESIGN	PLANNED				ACTUAL				COMMENTS	
			EXPOSURE TIME (SEC)	TRANSIT TIME (POST EXPOSURE)	TIME FROM F <sub>2</sub>	TIME SLICE	EST. PWR. AT TARGET	TOTAL POWER	ACTUAL SPOT DIAMETER			
1	PLEXI		1.0	6.5	14.00	13.5			56.9			
2												
3	# DOF		4.0	1.60	21.50	19.7			57.1			
4	# DOF		4.0	1.60	22.10							
5	# PE		4.0	1.60	32.70							
6	# PE		4.0	1.60	38.30							
		PLEXI	.10		43.90							
					44.00							
NOTE: DEVICES LOST POWER AT TWO SECONDS OF (RE OF 3 <sup>RD</sup> SPECIMEN)												

ITEM	START (SEC)	STOP (SEC)	ITEM	START (SEC)	STOP (SEC)
TV CAMERA No. 1	ON		O-GRAPH	MARK.	MAX
No. 2	"		SANGAMO No. 1	6.0	50.0
No. 3	"		SANGAMO No. 2	N/A	
No. 4	"		SABTS SEQ.	21.5	44.0
WIND TUNNEL	11.0	18.0	CALORIMETER (SABTS)	21.5	44.0
SABTS INST.			CALORIMETER (SLOW SHUTTER)	10.0	14.0
HEAT FLOW SENSOR	10.0	48.0	"	17.0	21.5
EFFECTS MIRROR	END OF 1		"	44.0	48.0

LASER PERFORMANCE ANALYSIS, RUN VLI-276

**BEAM INTENSITY PROFILE**

AS SEEN BY IR CAMERA VIEWING SECOND TURN FLAT

TOTAL INTENSITY

APPROX. TIME (SEC) 20

LINEAR PROFILE\*

APPROX. TIME (SEC) 20

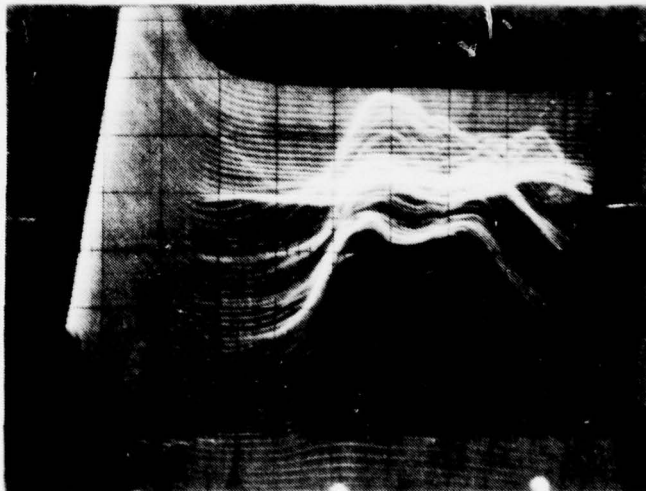
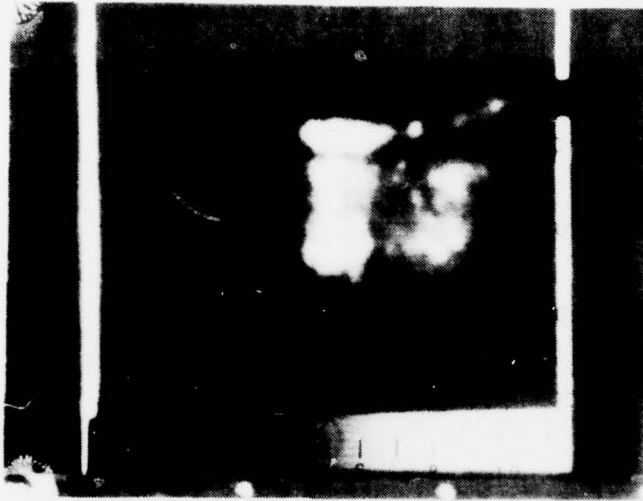

LEE BERGERSON

BEAM DIAGNOSTICS ENGINEER

LASER PERFORMANCE ANALYSIS - RUN NUMBER VL 1-277

### ESTIMATED POWER VS. TIME

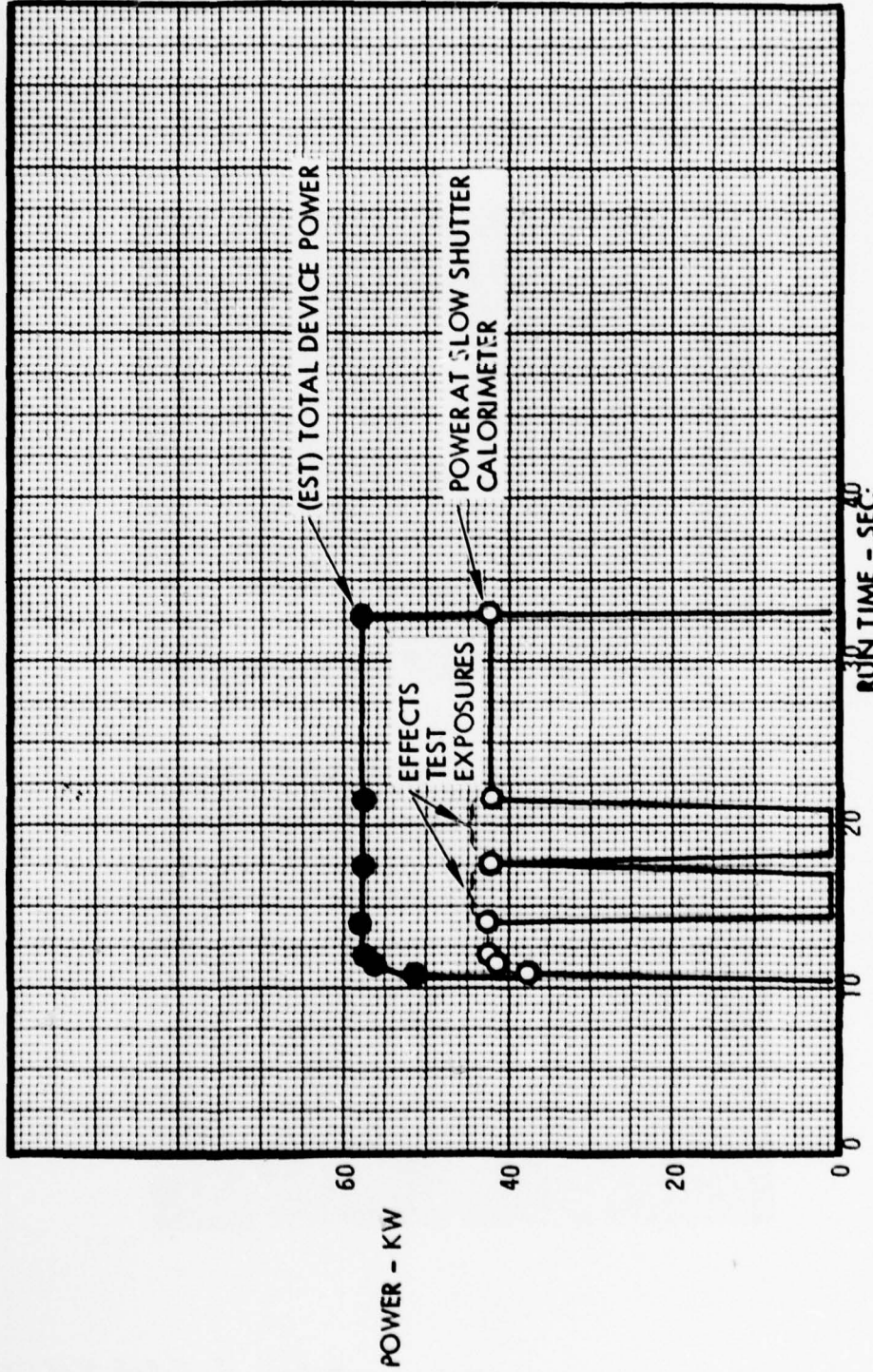

REMARKS: NO HEL SABTS EXPOSURE ACHIEVED ON THIS TEST.

PREPARED BY:

*J. SINGS*

2-22-77



• LASER PERFORMANCE ANALYSIS, RUN VLI-277

## BEAM INTENSITY PROFILE

AS SEEN BY IR CAMERA VIEWING SECOND TURN FLAT

TOTAL INTENSITY

APPROX. TIME (SEC) 20

LINEAR PROFILE\*

APPROX. TIME (SEC) N/A

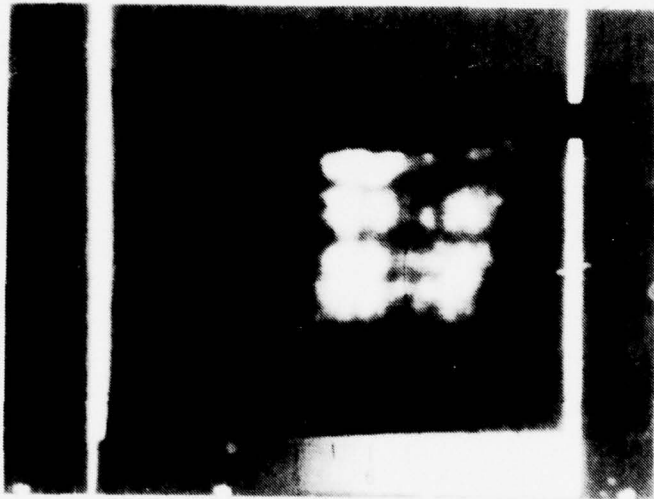

LASER PERFORMANCE ANALYSIS - RUN NUMBER VL 1-278

### ESTIMATED POWER VS. TIME

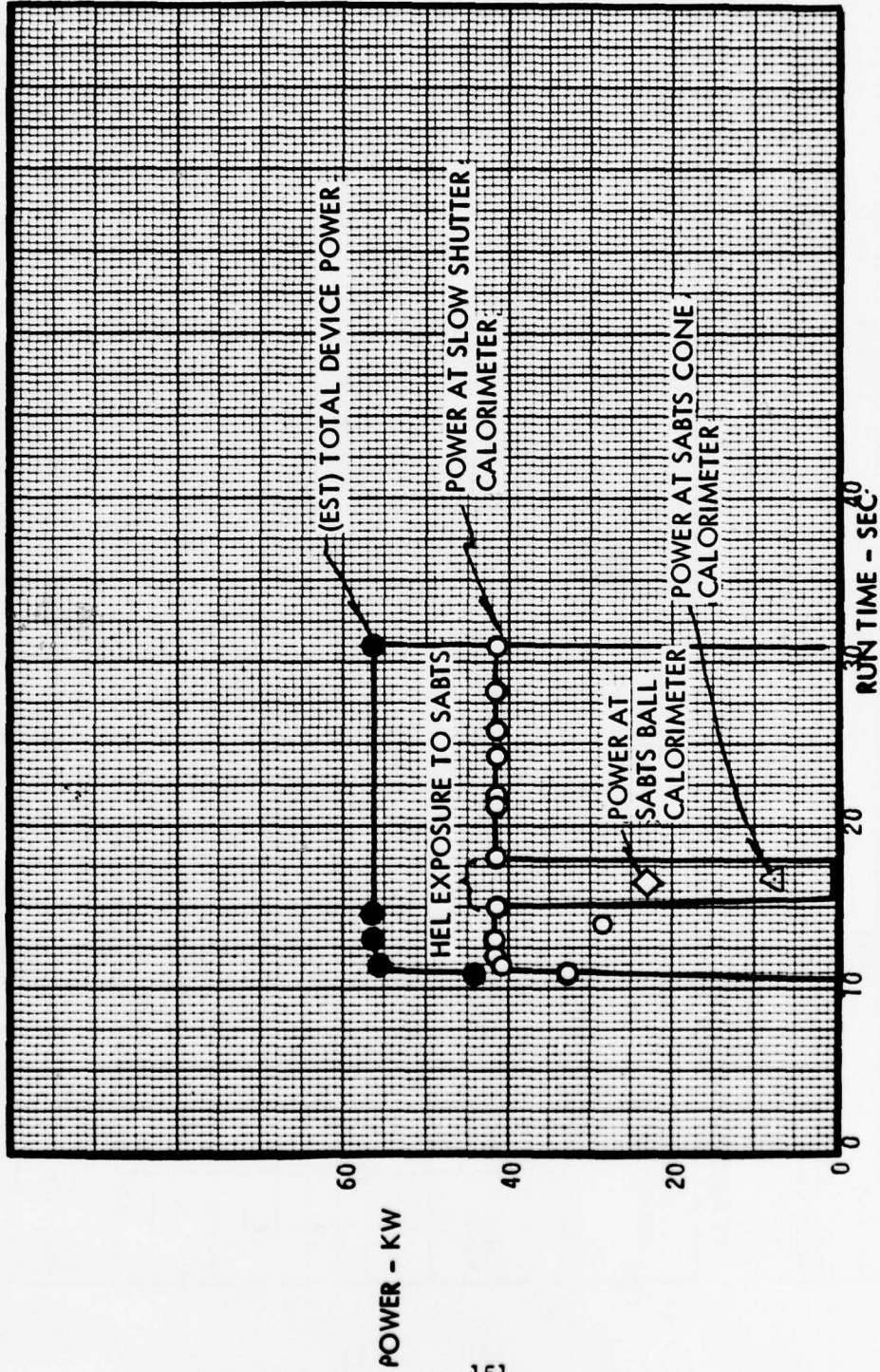

REMARKS: NO EFFECTS TEST ATTEMPTED

PREPARED BY:

*V. SINGH*  
2-23-77

**PLANNED TIME LINES AND QUICK LOOK DATA SHEET**

QUICK LOOK TEST DATA	
RUN NO. <b>VLI-278</b>	TEST PLAN <b>SABTS</b>
D2 FIRE VALVE OPEN (SEC) <b>10.4</b>	D2 FIRE VALVE CLOSED (SEC) <b>30.9</b>
DATE <b>2-23-77</b>	TIME <b>0145</b>
LASING DURATION (SEC) <b>20.5</b>	TOTAL COMPLETED TEST POSITIONS <b>1</b>
PLANNED TOTAL PWR. <b>59</b>	

PLANNED TEST NO. **GEY** TIME LINES AS OF DATE **2-22-77** REVISION **B**

EXPERIMENTER <b>D. MULLEN</b>	PLANNED LINEAR MAGNIFICATION <b>1.7</b>	CONFIGURATION <input checked="" type="checkbox"/> REFLECTIVE <input type="checkbox"/> TRANSMISSIVE
	PLANNED PEAK PWR DENSITY <b>10 KW/CM<sup>2</sup></b>	

TEST POSITION	SPECIMEN NO.	COATING DESIGN	PLANNED			ACTUAL			COMMENTS	
			EXPOSURE TIME (SEC)	TRANSIT TIME (POST EXPOSURE)	TIME FROM F <sub>2</sub>	TIME SLICE	EST. PWR. AT TARGET	TOTAL POWER		ACTUAL SPOT DIAMETER
1	* <b>HUGHES/DEF 4.0</b>				<b>21.70</b>	<b>13.5</b>				
2					<b>25.70</b>	<b>30.4</b>			<b>57.9</b>	
3									<b>57.6</b>	
4										
5										
6										

ITEM	START (SEC)	STOP (SEC)	ITEM	START (SEC)	STOP (SEC)
TV CAMERA No. 1	<b>ON</b>		O-GRAPH	<b>MAN.</b>	<b>MAN.</b>
No. 2	"		SANGAMO No. 1	<b>6.0</b>	<b>35.0</b>
No. 3	"		SANGAMO No. 2	<b>N/A</b>	
No. 4	"		SABTS SEQ.	<b>N/A</b>	
SABTS INST.			CALORIMETER (SABTS)	<b>21.7</b>	<b>25.7</b>
<b>EFFECT MIRROR</b>	<b>12.0</b>		CALORIMETER (SLOW SHUTTER)	<b>10.0</b>	<b>21.7</b>
<b>HI FLOW SOLENOID</b>	<b>21.0</b>	<b>33.0</b>	" " "	<b>21.7</b>	<b>33.0</b>

\* MANUFACTURED BY REF: ICP 4-2137; 3 OF 4

LASER PERFORMANCE ANALYSIS, RUN VLI-278

BEAM INTENSITY PROFILE

AS SEEN BY IR CAMERA VIEWING SECOND TURN FLAT

TOTAL INTENSITY

APPROX. TIME (SEC) 20

LINEAR PROFILE\*

APPROX. TIME (SEC) N/A

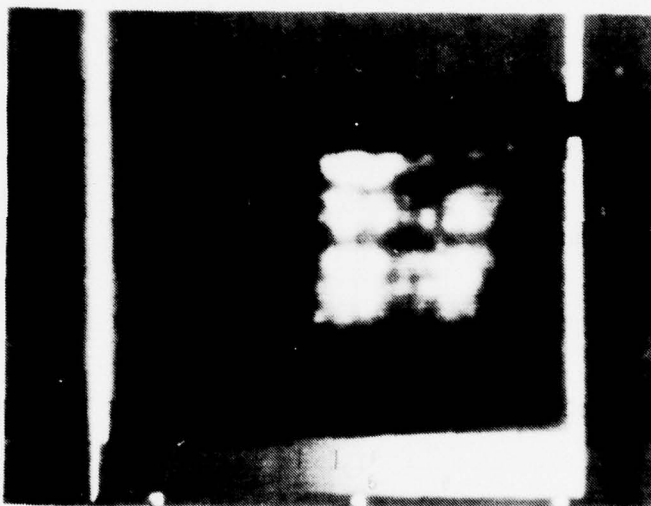

LEE BERGERSON

BEAM DIAGNOSTICS ENGINEER

LASER PERFORMANCE ANALYSIS - RUN NUMBER VL 1-279

### ESTIMATED POWER VS. TIME

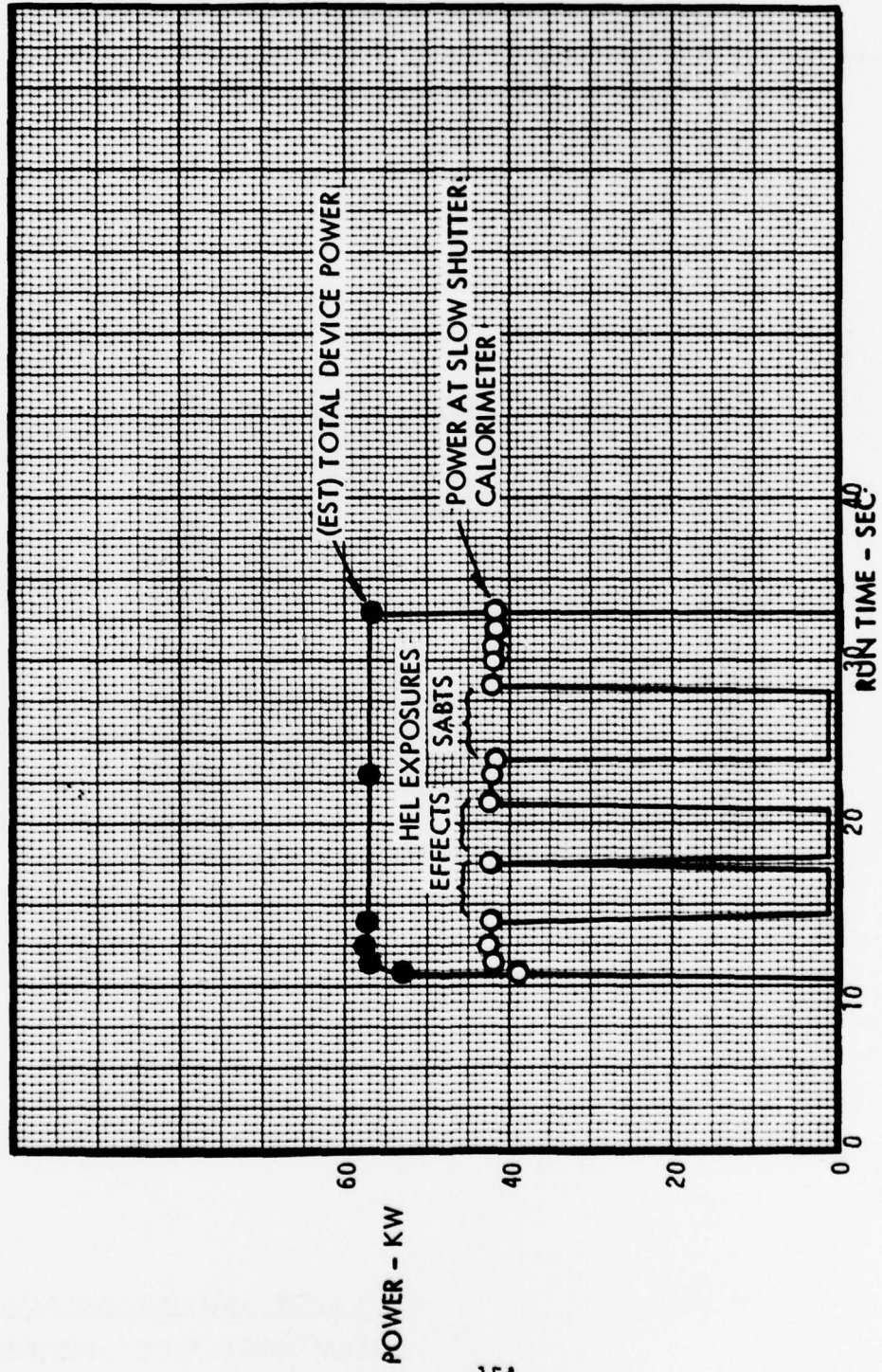

REMARKS:

PREPARED BY:  
*J. SINGS*  
2-24-77

# PLANNED TIME LINES AND QUICK LOOK DATA SHEET

RUP# NO.	TEST PLAN	DATE	TIME	PLANNED TOTAL PWR.
YL1-279	SABTS	2-24-77	1930	59
D2 FIRE VALVE OPEN (SEC)	D2 FIRE VALVE CLOSED (SEC)	LASING DURATION (SEC)	TOTAL COMPLETED TEST POSITIONS	
9.9	33.0	23.1	3	

PLANNED TEST NO. GE2 SW2/SCS2 TIME LINES AS OF DATE 2-25-77 REVISION CR16

EXPERIMENTER	PLANNED LINEAR MAGNIFICATION	CONFIGURATION
D. MULLEN	1.7	<input checked="" type="checkbox"/> REFLECTIVE
R. DELYER	10 KW/CM <sup>2</sup>	<input type="checkbox"/> TRANSMISSIVE

TEST POSITION	SPECIMEN NO.	COATING DESIGN	EXPOSURE TIME (SEC)	TRANSIT TIME (POST EXPOSURE)	TIME FROM F <sub>2</sub>	TIME SLICE	EST. PWR. AT TARGET	TOTAL POWER	ACTUAL SPOT DIAMETER	COMMENTS
1	SW2	0.160	3.0	1.10	14.00	13.0		58.6		
2	SCS3		3.0	4.0	18.10					
3										
4	#	MURKIN/DOF	4.0		25.10	22.2		58.0		
5					29.10	32.5		57.8		
6										

ITEM	START (SEC)	STOP (SEC)	ITEM	START (SEC)	STOP (SEC)
TV CAMERA No. 1	ON		O-GRAPH	MAN.	MAN.
No. 2	1.		SANGAMO No. 1	6.0	35.0
No. 3	"		SANGAMO No. 2	N/A	
No. 4	"		SABTS SEQ.	N/A	
WIND TUNNEL	15.0	22.0	CALORIMETER (SABTS)	25.1	29.1
GUILLOTINE	END OF 1		CALORIMETER (SLOW SHUTTER)	10.0	14.0
SPRINGS MIRAR	END OF 2		" "	21.1	25.1
HI FLOW SOLENOID	21.0	33.0	" "	27.1	33.0

\* PROMILER REF: TCR ME 21272 PAGE 3 OF 4

LASER PERFORMANCE ANALYSIS, RUN VLI-279

**BEAM INTENSITY PROFILE**

AS SEEN BY IR CAMERA VIEWING SECOND TURN PLAT

TOTAL INTENSITY  
APPROX. TIME (SEC) 20

LINEAR PROFILE\*  
APPROX. TIME (SEC) N/A

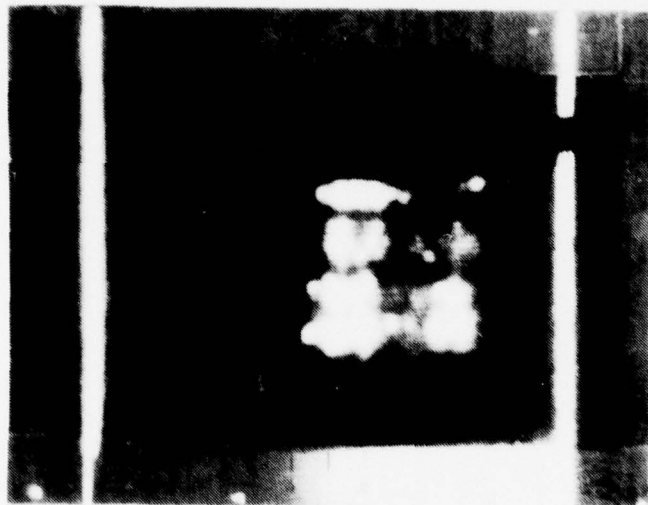

LASER PERFORMANCE ANALYSIS - RUN NUMBER VI 1-280

### ESTIMATED POWER VS. TIME

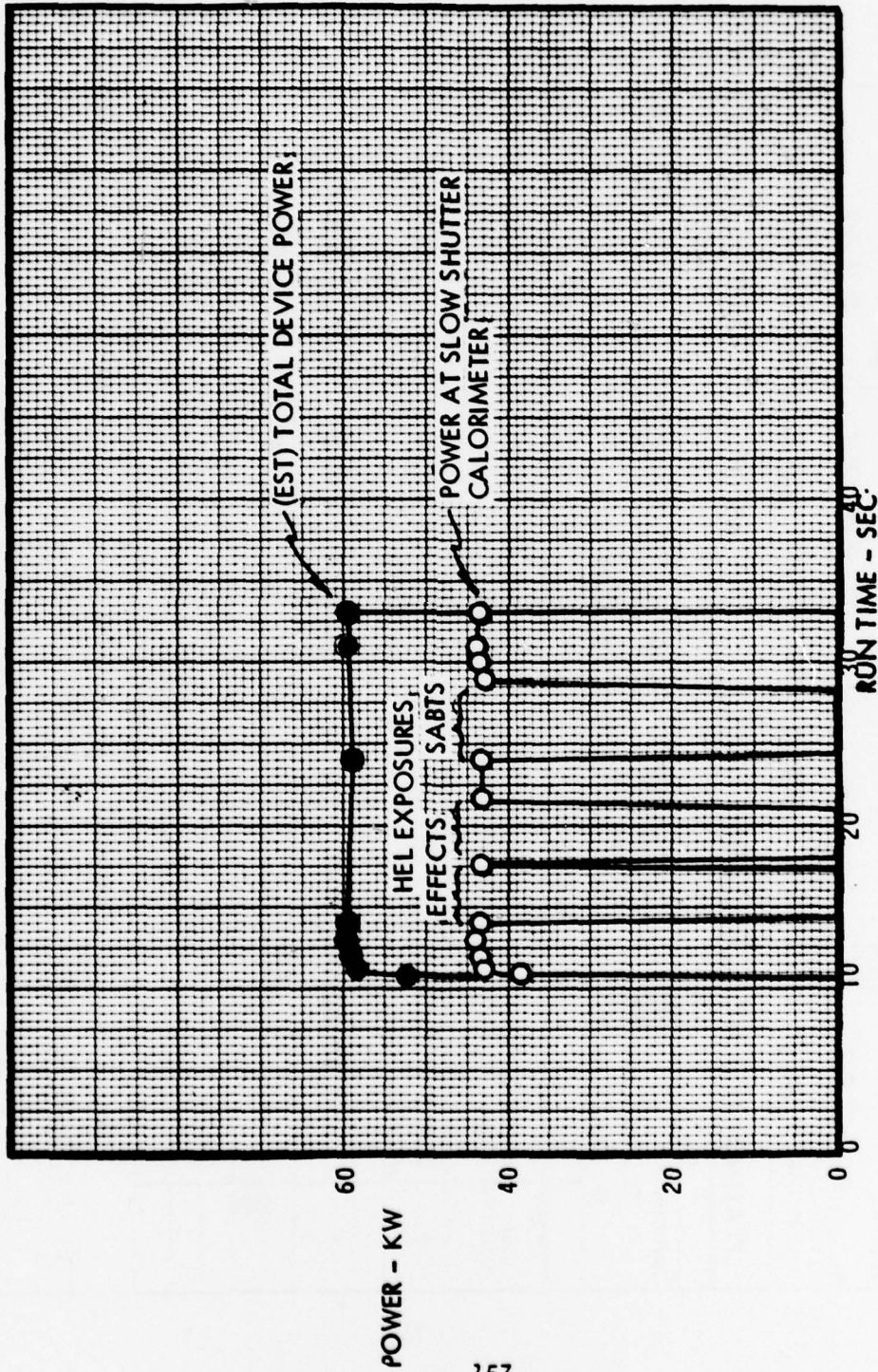

REMARKS: \_\_\_\_\_  
\_\_\_\_\_  
\_\_\_\_\_

PREPARED BY:

J. SINGH  
2-25-77

# PLANNED TIME LINES AND QUICK LOOK DATA SHEET

RUP# NO.	TEST PLAN	DATE	TIME	PLANNED TOTAL PWR.
KL1-280	SABITS	2-24-77	2210	59
D2 FIRE VALVE OPEN (SEC)	D2 FIRE VALVE CLOSED (SEC)	LASING DURATION (SEC)	TOTAL COMPLETED TEST POSITIONS	
10.4	33.0	22.6	3	

**PLANNED TEST NO. GE3 AS OF DATE 2-23-77 REVISION OR16**  
**TIME LINES**

EXPERIMENTER	CONFIGURATION
D. MULLAN	<input checked="" type="checkbox"/> REFLECTIVE
R. DELYON	<input type="checkbox"/> TRANSMISSIVE
PLANNED LINEAR MAGNIFICATION	PLANNED PEAK PWR DENSITY
2.7	30 KW/CM <sup>2</sup>

TEST POSITION	SPECIMEN NO.	COATING DESIGN	EXPOSURE TIME (SEC)	TRANSIT TIME (POST EXPOSURE)	TIME FROM F <sub>2</sub>	TIME SLICE	EST. PWR. AT TARGET	TOTAL POWER	ACTUAL SPOT DIAMETER	COMMENTS
1	SW3	9757	3.0	1.10	14.00	14.0		69.5		
2	H5E3		3.0	4.0	18.10					
3										
4	#	H5001/008	4.0		25.10	23.8		59.7		
5					29.10					
6						31.4		59.7		

ITEM	START (SEC)	STOP (SEC)	ITEM	START (SEC)	STOP (SEC)
TV CAMERA No. 1	ON		O-GRAPH	MAN.	MAN.
No. 2	"		SANGAMO No. 1	6.0	35.0
No. 3	"		SANGAMO No. 2	N/A	
No. 4	"		SABITS SEC.	N/A	
WIND TUNNEL	15.0	22.0	CALORIMETER (SABITS)	25.1	29.1
GUILLOTINE	END OF 1		CALORIMETER (SLOW SHUTTER)	10.0	14.0
EFFECTS MIRROR	END OF 2		"	21.1	25.1
HIGH SPEED SOLANOID	21.0	33.0	"	29.1	33.0

LASER PERFORMANCE ANALYSIS, RUN VLI-280

**BEAM INTENSITY PROFILE**

AS SEEN BY IR CAMERA VIEWING SECOND TURBINE FLAT

TOTAL INTENSITY  
APPROX. TIME (SEC) 20

LINEAR PROFILE\*  
APPROX. TIME (SEC) N/A

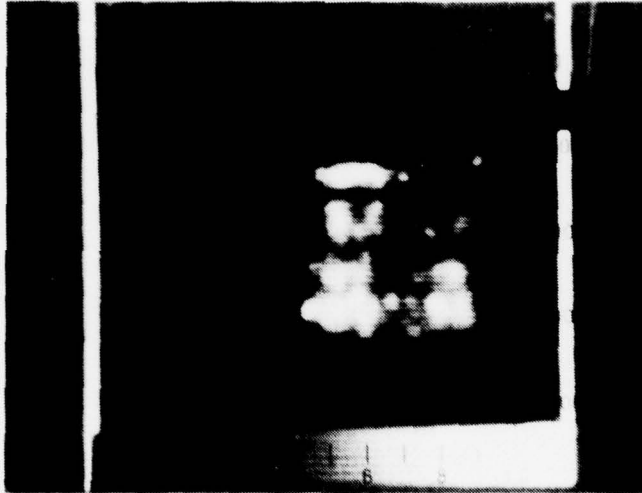

LIEK BERGARSON  
BEAM DIAGNOSTICS ENGINEER

LASER PERFORMANCE ANALYSIS - RUN NUMBER VL 1-281

### ESTIMATED POWER VS. TIME

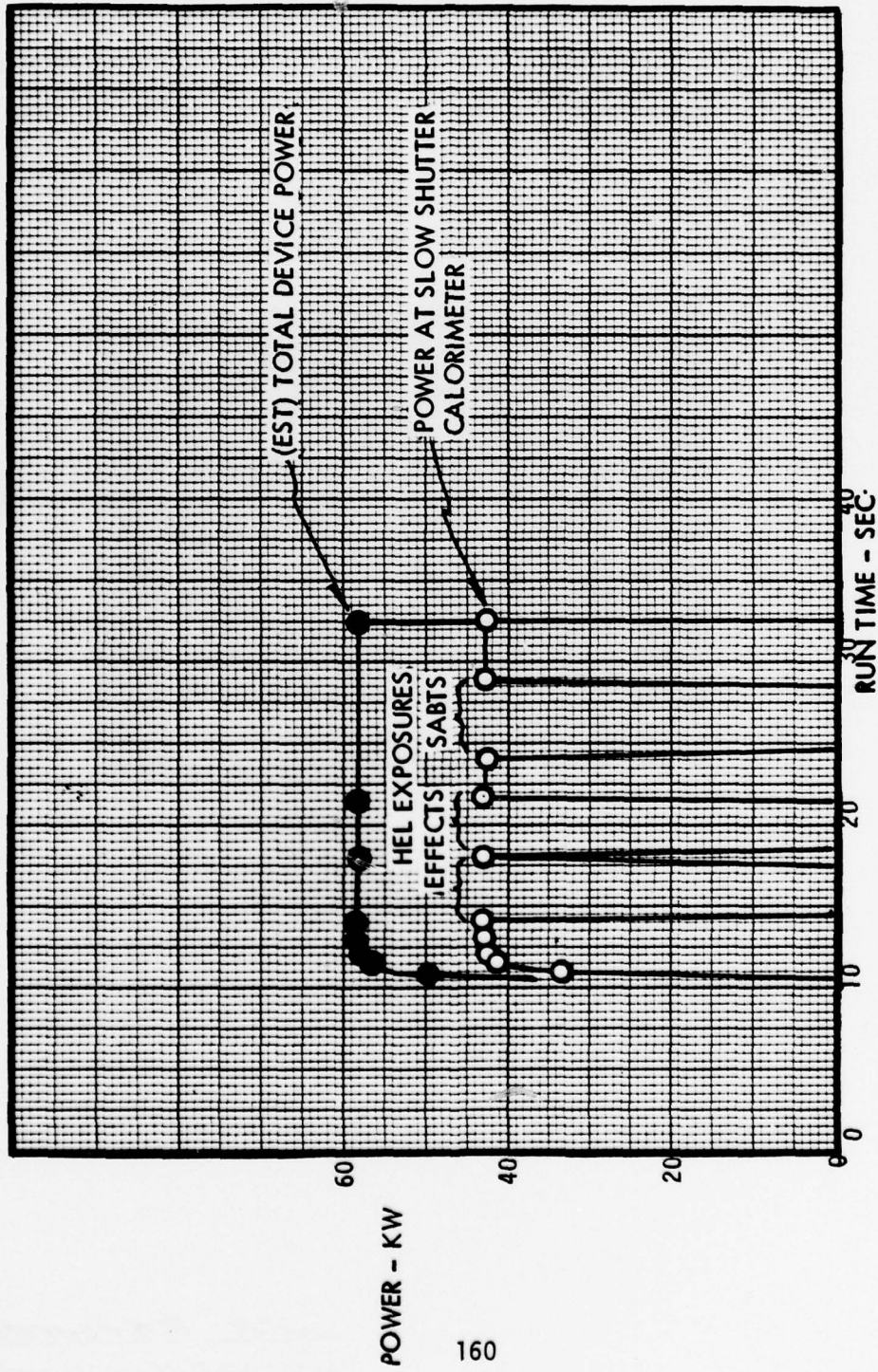

REMARKS:

PREPARED BY:

*L. SINGS*  
2-25-77

POWER - KW

**PLANNED TIME LINES AND QUICK LOOK DATA SHEET**

QUICK LOOK TEST DATA	
RUN NO. <b>VLI-281</b>	DATE <b>2-25-77</b>
TEST PLAN <b>SABTS</b>	TIME <b>0039</b>
D2 FIRE VALVE CLOSED (SEC) <b>9.9</b>	DURATION (SLC) <b>22.6</b>
D2 FIRE VALVE OPEN (SEC) <b>32.5</b>	TOTAL COMPLETED TEST POSITIONS <b>3</b>
PLANNED TEST NO. <b>GE4 SW4/MS9</b>	PLANNED TOTAL PWK. <b>59</b>
AS OF <b>TIME LINES</b>	DATE <b>2-23-77</b>
REVISION <b>ORIG</b>	

EXPERIMENTER <b>D. MULLAN</b> <b>R. DALYDA</b>	PLANNED LINEAR MAGNIFICATION <b>2.7</b>	CONFIGURATION <input checked="" type="checkbox"/> REFLECTIVE <input type="checkbox"/> TRANSMISSIVE
PLANNED PEAK PWR DENSITY <b>30 KW/CM<sup>2</sup></b>	PLANNED	

TEST POSITION	SPECIMEN NO.	COATING DESIGN	EXPOSURE TIME (SEC)	TRANSIT TIME (POST EXPOSURE)	TIME FROM F <sub>2</sub>	TIME SLICE	EST. PWK. AT TARGET	TOTAL POWER	ACTUAL SPOT DIAMETER	COMMENTS
1	SW4	9753	3.0	1.10	14.00	14.0		59.2		
2	HSS4		3.0	4.0	18.10					
3										
4	# HUGHES/DOF		4.0		25.10	23.8		58.6		
5					29.10					
6						31.4		58.8		

ITEM	START (SEC)	STOP (SEC)	ITEM	START (SEC)	STOP (SEC)
TV CAMERA No. 1	ON		O-GRAPH	MAN.	MAN.
No. 2	"		SANIGAMO No. 1	6.0	35.0
No. 3	"		SANIGAMO No. 2	N/A	
No. 4	"		SABTS SEQ.	N/A	
WIND TUNNEL	15.0	22.0	CALORIMETER (SABTS)	25.1	29.1
GUILLOTINE	END OF 1		CALORIMETER (SLOW SHUTTER)	10.0	14.0
EFFRETTI MIRROR	END OF 2		"	21.1	25.1
HIFLOW POLAROID	21.0	33.0	"	29.1	33.0

LASER PERFORMANCE ANALYSIS, RUN VLI-581

**BEAM INTENSITY PROFILE**

AS SEEN BY IR CAMERA VIEWING SECOND TURN FLAT

TOTAL INTENSITY  
APPROX. TIME (SEC) 20

LINEAR PROFILE\*  
APPROX. TIME (SEC) N/A

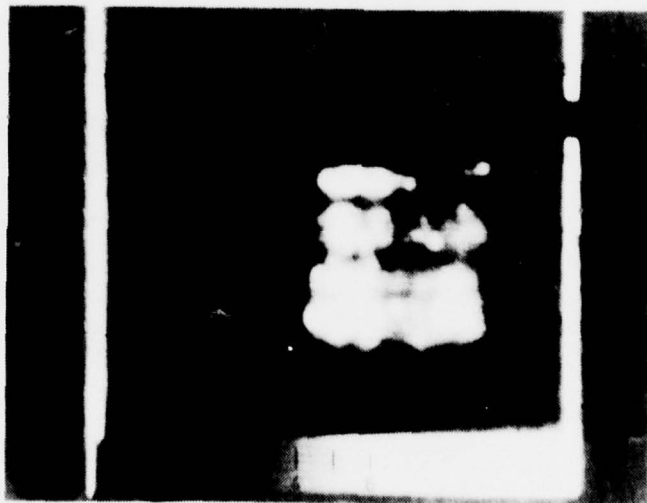

LEE BERGERSON  
BEAM DIAGNOSTICS ENGINEER

LASER PERFORMANCE ANALYSIS - RUN NUMBER VL 1-282

### ESTIMATED POWER VS. TIME

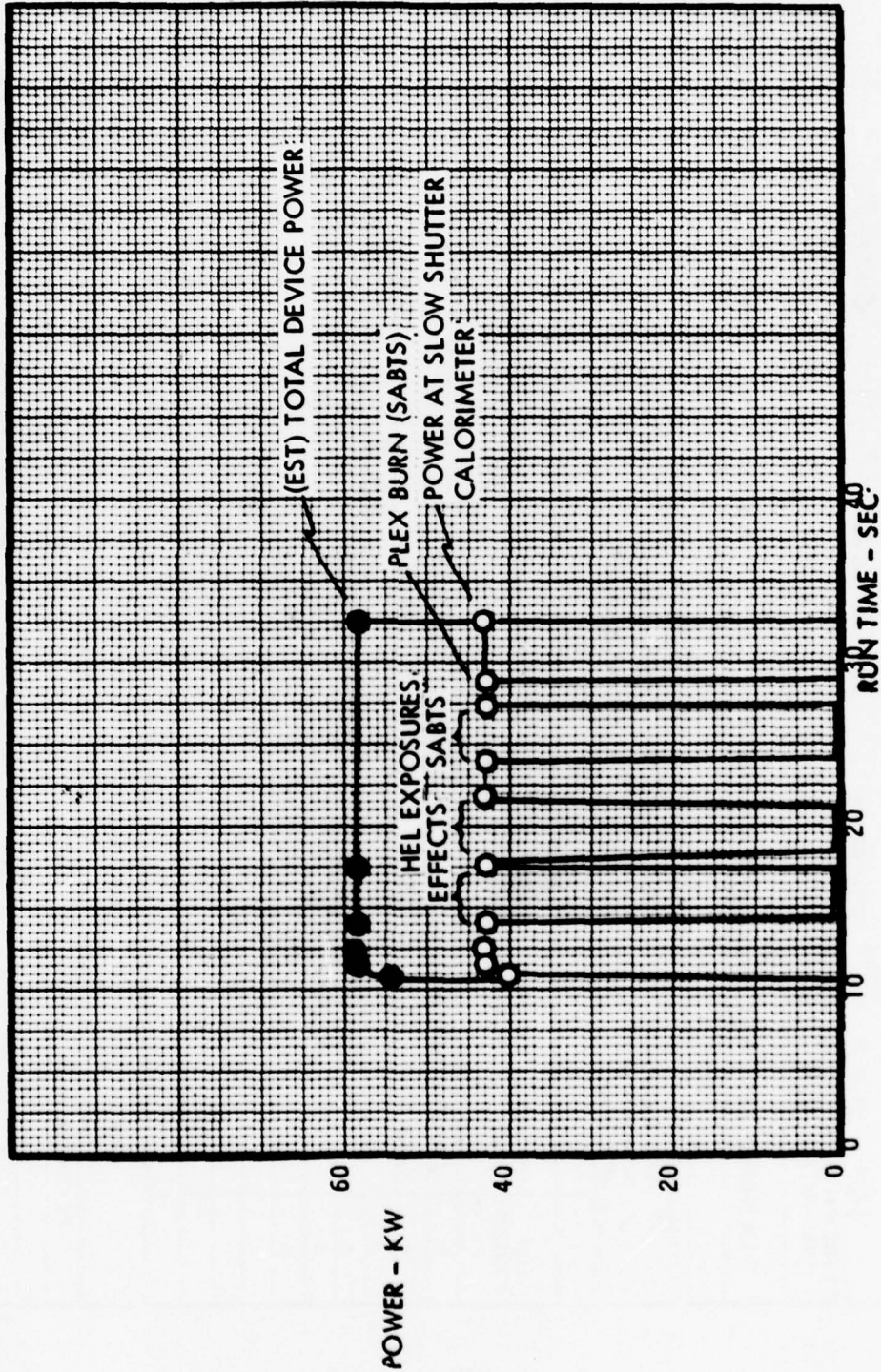

REMARKS:

PREPARED BY:

J. S. NG  
2-26-77

**PLANNED TIME LINES AND QUICK LOOK DATA SHEET**

QUICK LOOK TEST DATA										
RUN NO.	TEST PLAN	DATE	TIME	TOTAL COMPLETED TEST POSITIONS	PLANNED TOTAL PWR.					
VLI - 282	SABTS	2-26-77	0047	4	59					
D2 FIRE VALVE OPEN (SEC)	D2 FIRE VALVE CLOSED (SEC)	LASING DURATION (SEC)								
9.9	32.5	22.6								
GBS PLANNED TEST NO. SWS/SNR/ TIME LINES AS OF DATE 2-25-77 REVISION 0R16										
EXPERIMENTER	PLANNED LINEAR MAGNIFICATION	PLANNED PEAK PWR DENSITY	CONFIGURATION		ACTUAL					
			<input checked="" type="checkbox"/> REFLECTIVE	<input type="checkbox"/> TRANSMISSIVE						
D. MULLEN J. MARKER J. EVANS	1.7	10 KW/CM <sup>2</sup>								
TEST POSITION	SPECIMEN NO.	COATING DESIGN	EXPOSURE TIME (SEC)	TRANSIT TIME (POST EXPOSURE)	TIME FROM F <sub>2</sub>	TIME SLICE	EST. PWR. AT TARGET	TOTAL POWER	ACTUAL SPOT DIAMETER	COMMENTS
1	SWS	0160	3.0	1.10	14.00	13.0		57.5		
2	SHR1		2.0	4.00	18.10	23.2		59.3		
3										
4	W	PE/PE	4.0	1.10	24.10					
5		PLEX1	0.1		29.20					
6					29.30	31.9		59.3		
ITEM	START (SEC)	STOP (SEC)	ITEM	START (SEC)	STOP (SEC)					
TV CAMERA No. 1	ON		O-GRAPH	MAN.	MAN.					
No. 2	"		SANGAMO No. 1	6.0	34.0					
No. 3	"		SANGAMO No. 2	N/A						
No. 4	"		SABTS SEQ.	N/A						
GUILLOTINE	END OF 1		CALORIMETER (SABTS)	24.1	28.1					
SABTS INST.			CALORIMETER (SLOW SHUTTER)	10.0	14.0					
EFFECTY MIRROR	END OF 2			20.1	24.1					
HI FLOW SOLENOID	21.0	32.0		27.3	33.0					
W PROFILER										

LASER PERFORMANCE ANALYSIS, RUN VLI-282

**BEAM INTENSITY PROFILE**

AS SEEN BY IR CAMERA VIEWING SECOND TURN FLAT

TOTAL INTENSITY  
APPROX. TIME (SEC) 20

LINEAR PROFILE\*  
APPROX. TIME (SEC) N/A

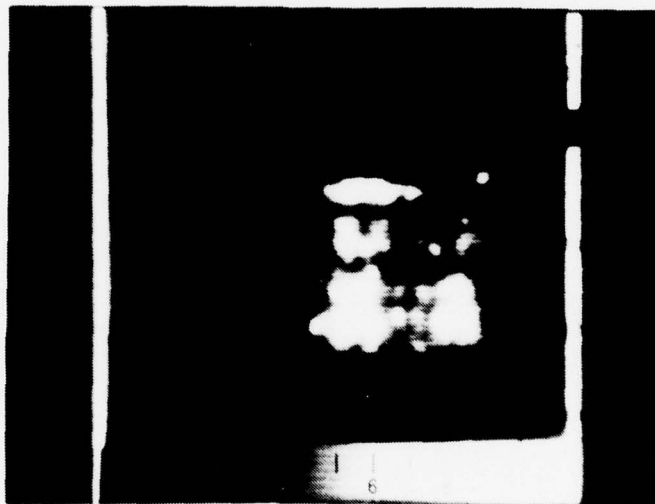

LEE BERGERION  
BEAM DIAGNOSTICS ENGINEER

**ESTIMATED POWER VS. TIME**

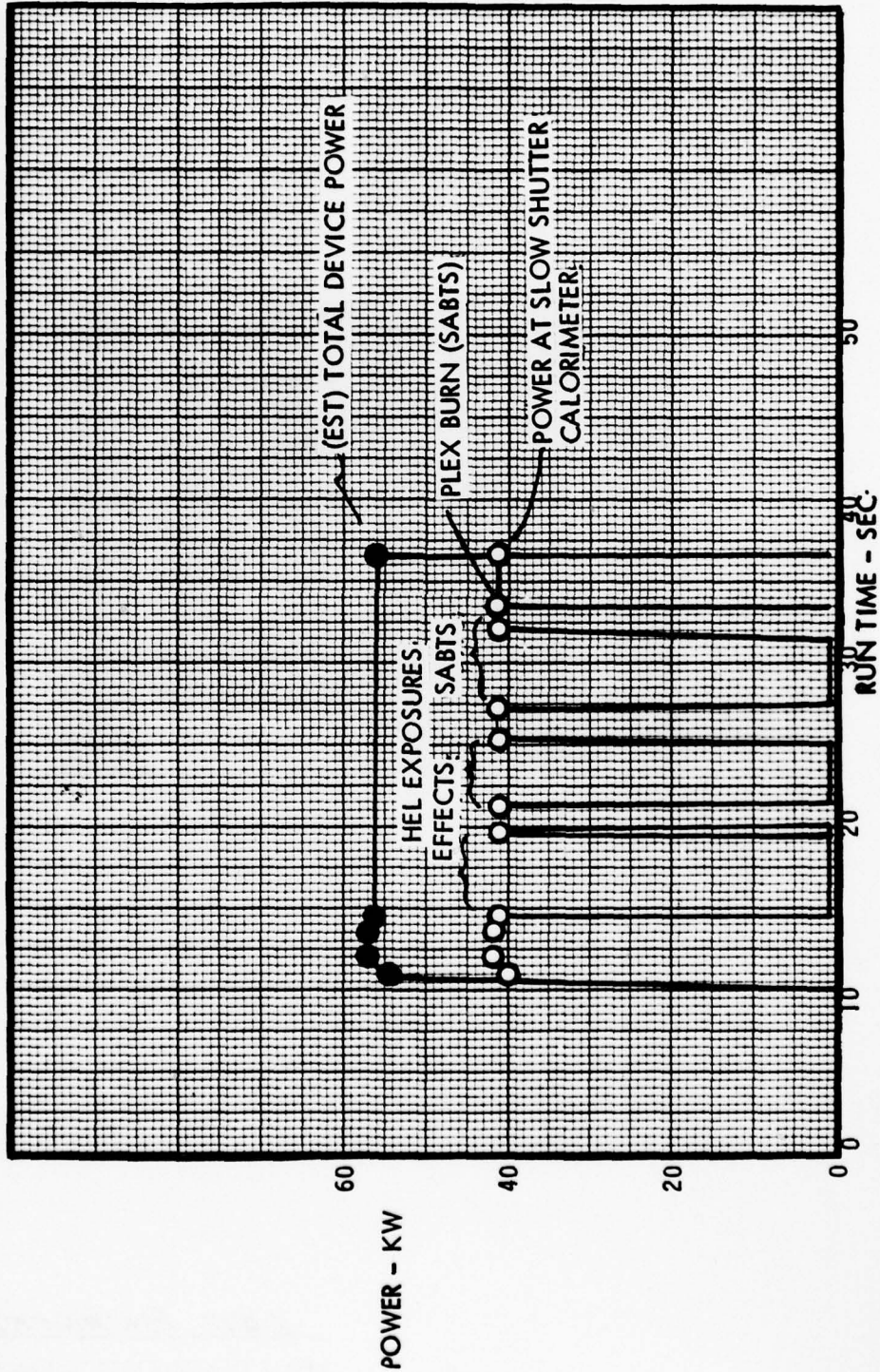

REMARKS:

PREPARED BY:

J. SINGS

**PLANNED TIME LINES AND QUICK LOOK DATA SHEET**

QUICK LOOK TEST DATA

RUN NO.	TEST PLAN	DATE	TIME
VLL-283	SABTS	2-26-77	2148
D2 FIRE VALVE OPEN (SEC)	D2 FIRE VALVE CLOSED (SEC)	LASING DURATION (SEC)	TOTAL COMPLETED TEST POSITIONS
9.9	36.6	26.7	4
PLANNED TEST NO. <b>GAC6</b>			PLANNED TOTAL PWR. <b>57</b>

AS OF DATE **2-26-77** REVISION **B**

EXPERIMENTER	PLANNED LINEAR MAGNIFICATION	CONFIGURATION
D. MULLEN	2.7	<input checked="" type="checkbox"/> REFLECTIVE
P. RAGLIN	PLANNED PEAK PWR DENSITY <b>30 KW/CM<sup>2</sup></b>	<input type="checkbox"/> TRANSMISSIVE

TEST POSITION	SPECIMEN NO.	COATING DESIGN	PLANNED				ACTUAL				COMMENTS
			EXPOSURE TIME (SEC)	TRANSIT TIME (POST EXPOSURE)	TIME FROM F <sub>2</sub>	TIME SLICE	EST. PWR. AT TARGET	TOTAL POWER	ACTUAL SPOT DIAMETER		
1	SABTS		4.0	1.10	19.00	13.5		57.9			
2	MARK I		5.0	4.00	19.10	27.3		57.0			
3											
4	* HUGHES/DNF		4.0	1.10	28.10						
5	PLEXI		0.1		33.20						
6					33.30			57.2			

ITEM	START (SEC)	STOP (SEC)	ITEM	START (SEC)	STOP (SEC)
TV CAMERA No. 1	ON		O-GRAPH	MAN.	MAN.
No. 2	"		SANGAMO No. 1	6.0	39.0
No. 3	"		SANGAMO No. 2	N/A	
No. 4	"		SABTS SEQ.	N/A	
GUILLOTINE	END OF 1		CALORIMETER (SABTS)	28.10	33.20
SABTS INST.			CALORIMETER (SLOW SHUTTER)	10.0	14.0
EFFECTY MIRROR	END OF 2		"	24.1	29.1
HL FLOW SOLAROID	21.0		"	33.3	37.0

\* PROFILER REF: TCR ML 21372 PAGE **3** OF **4**

LASER PERFORMANCE ANALYSIS, RUN VLI-283

**BEAM INTENSITY PROFILE**

AS SEEN BY IR CAMERA VIEWING SECOND TURN FLAT

TOTAL INTENSITY  
APPROX. TIME (SEC) 20

LINEAR PROFILE\*  
APPROX. TIME (SEC) N/A

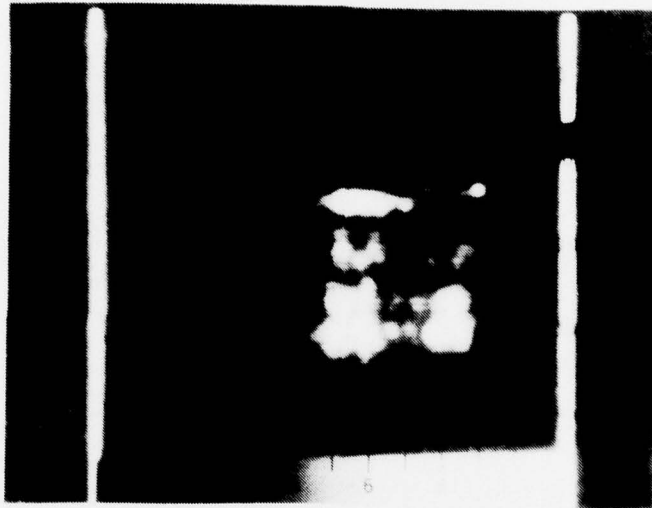

LEE BERGERSON  
BEAM DIAGNOSTICS ENGINEER

LASER PERFORMANCE ANALYSIS - RUN NUMBER VL 1-284

### ESTIMATED POWER VS. TIME

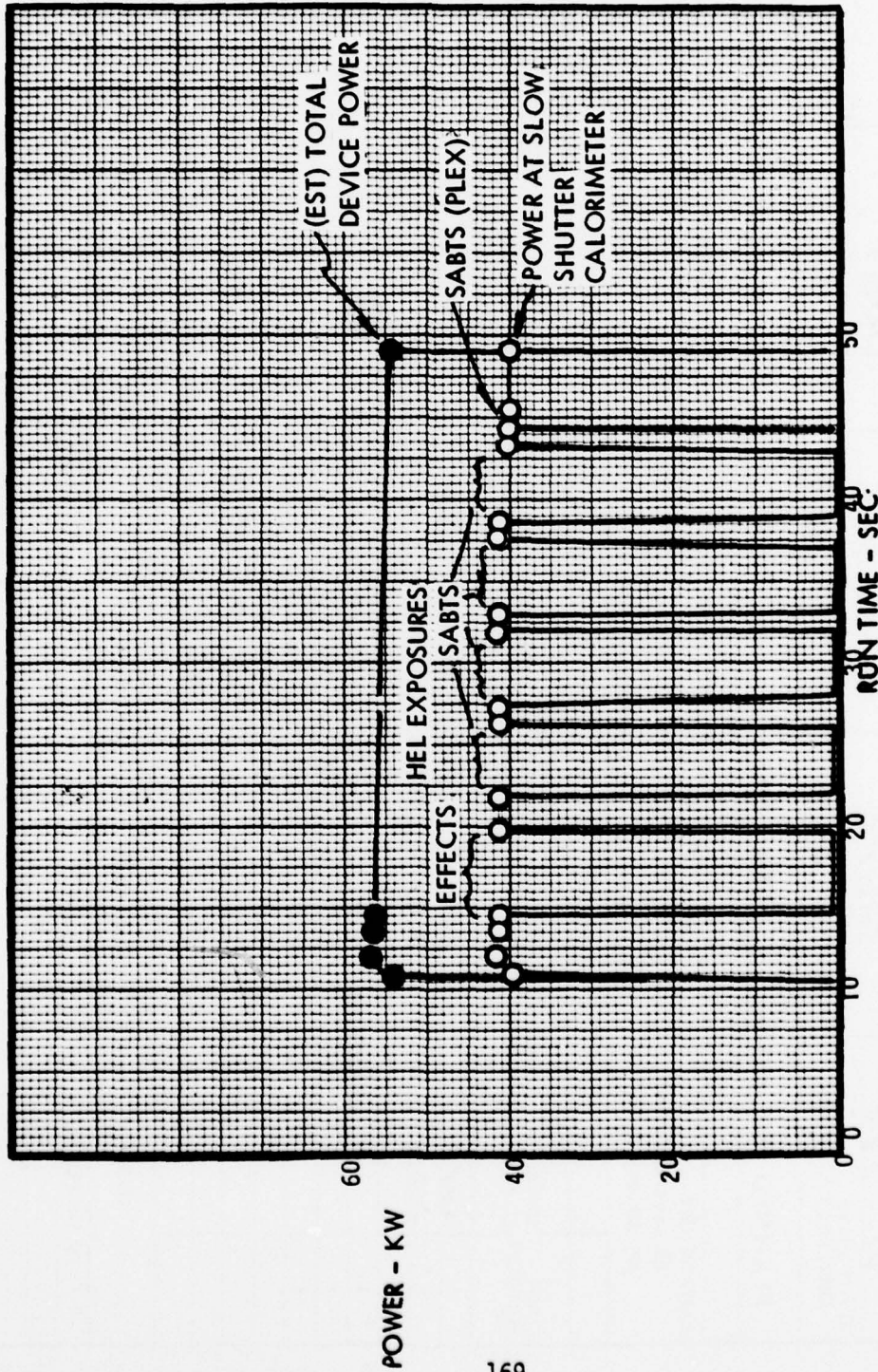

REMARKS:

PREPARED BY: L. Stalger

**PLANNED TIME LINES AND QUICK LOOK DATA SHEET**

QUICK LOOK TEST DATA	
RUN NO.	DATE
<b>VLL-284</b>	<b>2-27-77</b>
TEST PLAN	TIME
<b>SABTS</b>	<b>0001</b>
D2 FIRE VALVE OPEN (SEC)	TOTAL COMPLETED TEST POSITIONS
<b>9.9</b>	<b>7</b>
D2 FIRE VALVE CLOSED (SEC)	PLANNED TOTAL PWIR.
<b>49.0</b>	<b>59</b>

PLANNED TEST NO. **657** AS OF DATE **2-26-77** REVISION **B**

EXPERIMENTER	PLANNED LINEAR MAGNIFICATION	CONFIGURATION
<b>D. MULLAN</b>	<b>2.7</b>	<input checked="" type="checkbox"/> REFLECTIVE
<b>P. RAGLIN</b>	PLANNED PEAK PWR DENSITY	<input type="checkbox"/> TRANSMISSIVE
	<b>30 KW/CM<sup>2</sup></b>	

TEST POSITION	PLANNED						ACTUAL			
	SPECIMEN NO.	COATING DESIGN	EXPOSURE TIME (SEC)	TRANSIT TIME (POST EXPOSURE)	TIME FROM F <sub>2</sub>	TIME SLICE	EST. PWR. AT TARGET	TOTAL POWER	ACTUAL SPOT DIAMETER	COMMENTS
1	<b>SRR3</b>		<b>6.0</b>	<b>1.10</b>	<b>14.00</b>	<b>13.0</b>		<b>57.6</b>		
2	<b>ARPA1</b>		<b>3.0</b>	<b>1.10</b>	<b>21.10</b>					
3										
4	<b># HIGHT/low</b>		<b>4.0</b>	<b>1.70</b>	<b>25.20</b>					
5	"		<b>4.0</b>	<b>1.70</b>	<b>30.90</b>					
6	"		<b>4.0</b>	<b>1.70</b>	<b>36.60</b>					
	"		<b>4.0</b>	<b>1.70</b>	<b>42.30</b>					
	<b>PLEX1</b>		<b>0.1</b>		<b>48.00</b>	<b>47.8</b>		<b>56.9</b>		
					<b>48.10</b>					

ITEM	START (SEC)	STOP (SEC)	ITEM	START (SEC)	STOP (SEC)
TV CAMERA No. 1	<b>ON</b>		O-GRAPH	<b>MAN.</b>	<b>MAN.</b>
No. 2	"		SANIGAMO No. 1	<b>6.0</b>	<b>53.0</b>
No. 3	"		SANIGAMO No. 2	<b>N/A</b>	
No. 4	"		SABTS SEQ.	<b>16.0</b>	
<b>GULLOTTINE</b>	<b>END OF 1</b>		CALCRIMETER (SABTS)	<b>25.2</b>	<b>48.0</b>
SABTS INST.	<b>END OF 2</b>		CALCRIMETER (SLOW SHUTTER)	<b>10.0</b>	<b>14.0</b>
<b>HI FLOW SPANDID</b>	<b>21.0</b>			<b>24.1</b>	<b>25.2</b>
<b>* PROFILER</b>				<b>49.1</b>	<b>52.0</b>

LASER PERFORMANCE ANALYSIS, RUN VLI-284

BEAM INTENSITY PROFILE

AS SEEN BY IR CAMERA VIEWING SECOND TURN FLAT

TOTAL INTENSITY  
APPROX. TIME (SEC) 20

LINEAR PROFILE\*  
APPROX. TIME (SEC) N/A

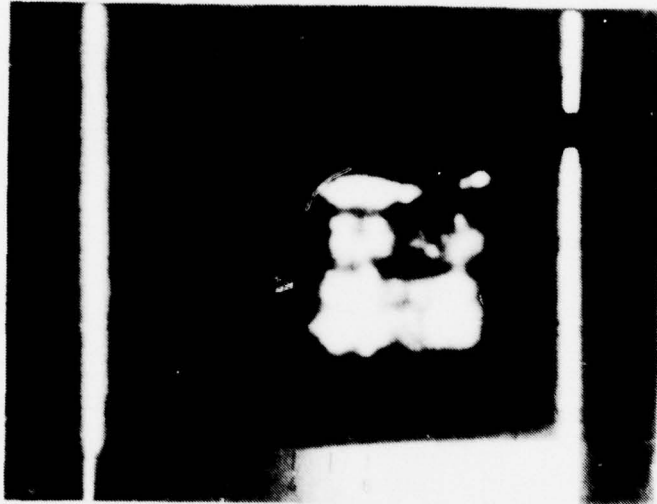

LEIF BERGERSON  
BEAM DIAGNOSTICS ENGINEER

LASER PERFORMANCE ANALYSIS - RUN NUMBER VL 1-285

### ESTIMATED POWER VS. TIME

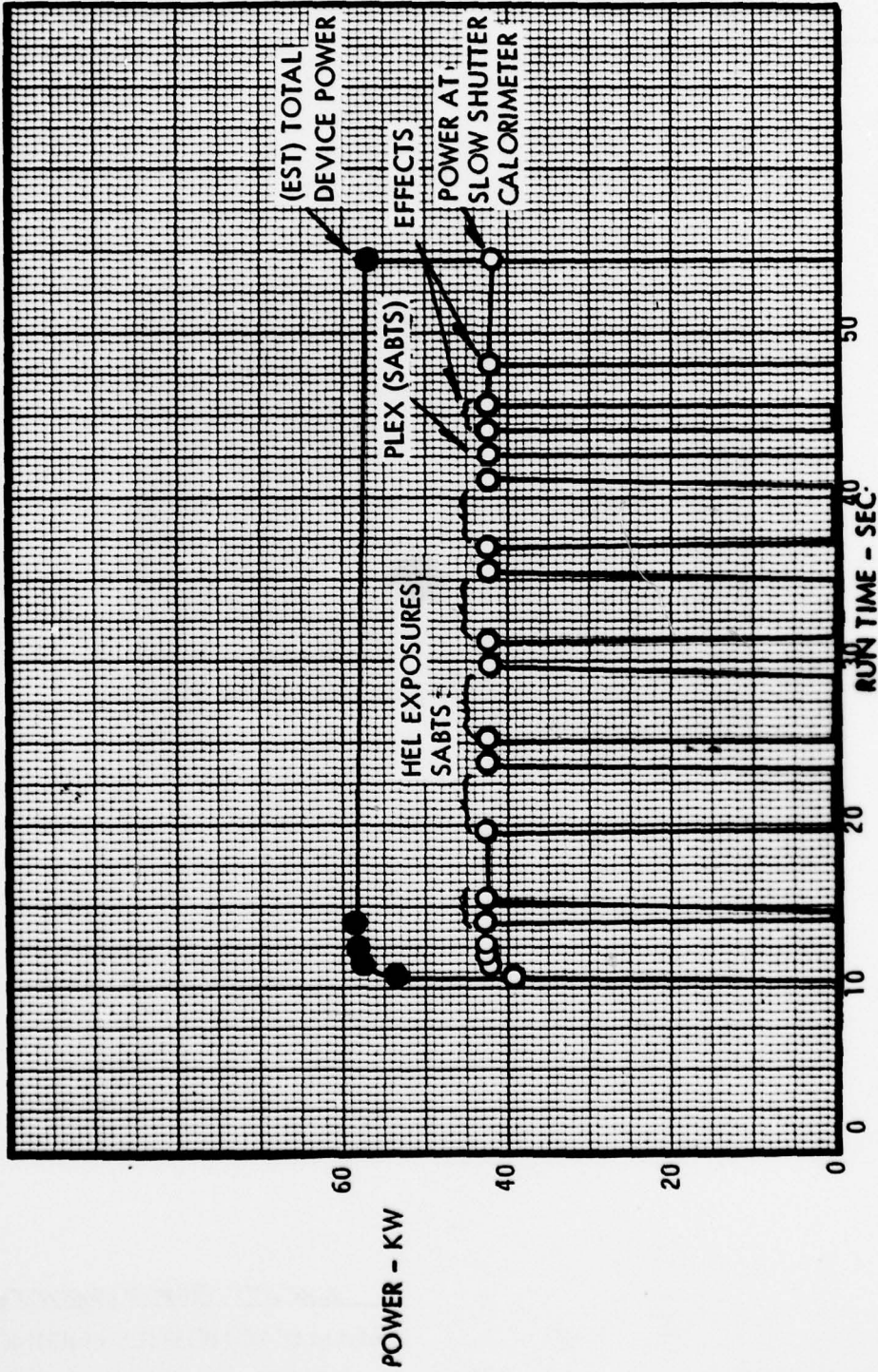

REMARKS:

PREPARED BY: J. SINGS  
3-1-77

**PLANNED TIME LINES AND QUICK LOOK DATA SHEET**

QUICK LOOK TEST DATA			
RUN NO.	TEST PLAN	DATE	TIME
<b>YLI-285</b>	<b>SABTS</b>	<b>2-28-77</b>	<b>2147</b>
D2 FIRE VALVE OPEN (SEC)	D2 FIRE VALVE CLOSED (SEC)	LASING DURATION (SEC)	TOTAL COMPLETED TEST POSITIONS
<b>10.4</b>	<b>54.5</b>	<b>44.1</b>	<b>8</b>
PLANNED TOTAL PWR.			<b>59</b>

PLANNED TEST NO. **0620/AN** TIME LINES AS OF DATE **2-28-77** REVISION **A**

EXPERIMENTER	PLANNED LINEAR MAGNIFICATION	CONFIGURATION
<b>D. MULLEN</b>	<b>3.1</b>	<input checked="" type="checkbox"/> REFLECTIVE <input type="checkbox"/> TRANSMISSIVE
	PLANNED PEAK PWR DENSITY	
	<b>≈ 25 kW/cm<sup>2</sup></b>	

TEST POSITION	SPECIMEN NO.	COATING DESIGN	EXPOSURE TIME (SEC)	TRANSIT TIME (POST EXPOSURE)	TIME FROM F <sub>2</sub>	TIME SLICE	EST. PWR. AT TARGET	TOTAL POWER	ACTUAL SPOT DIAMETER	COMMENTS
1	*	DOF 5	4.0	1.70	14.00	14.0		58.9		
2		DOF 6	4.0	1.70	19.70					
3		DOF 8	4.0	1.70	25.40					
4		HOUSE 107	4.0	1.70	31.10					
5	*	HOUSE 103	4.0	1.70	36.80					
6		PLEXI	0.1	1.10	42.50					
7										
8	ANT 1		3.0	1.10	43.70					
9	BALCAL		3.0		47.50					
10					50.90	54.5		57.9		

ITEM	START (SEC)	STOP (SEC)	ITEM	START (SEC)	STOP (SEC)
TV CAMERA No. 1	ON		O-GRAPH	MAN.	MAN.
No. 2	"		SANGAMO No. 1	6.0	57.0
No. 3	"		SANGAMO No. 2	N/A	
No. 4	"		SABTS SEQ.	N/A	
GUILLOTINE	END OF 8		CALORIMETER (SABTS)	14.0	42.5
SABTS INST.			CALORIMETER (SLOW SHUTTER)	10.0	14.0
EFFECTS MIRROR	END OF 6		"	50.8	55.0
HI FLOW SOLENOID	10.0	55.0	MOVIE CAMERA	42.0	55.0

LASER PERFORMANCE ANALYSIS, RUN VLI-285

**BEAM INTENSITY PROFILE**

AS SEEN BY IR CAMERA VIEWING SECOND TURN FLAT

TOTAL INTENSITY  
APPROX. TIME (SEC) 20

LINEAR PROFILE\*  
APPROX. TIME (SEC) N/A

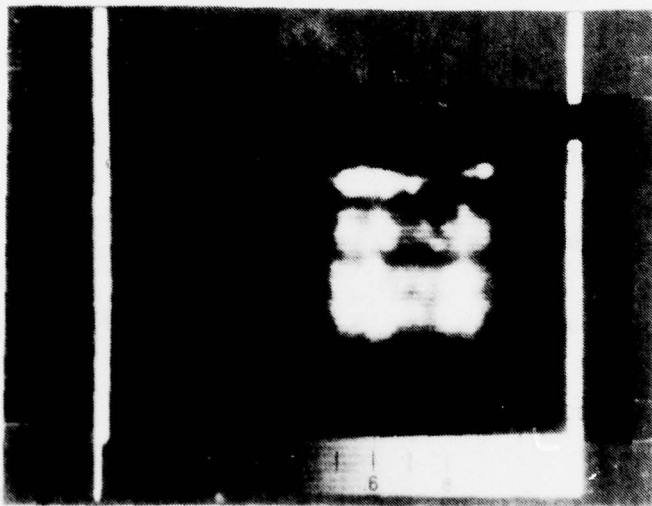

LASER PERFORMANCE ANALYSIS - RUN NUMBER VL 1-286

### ESTIMATED POWER VS. TIME

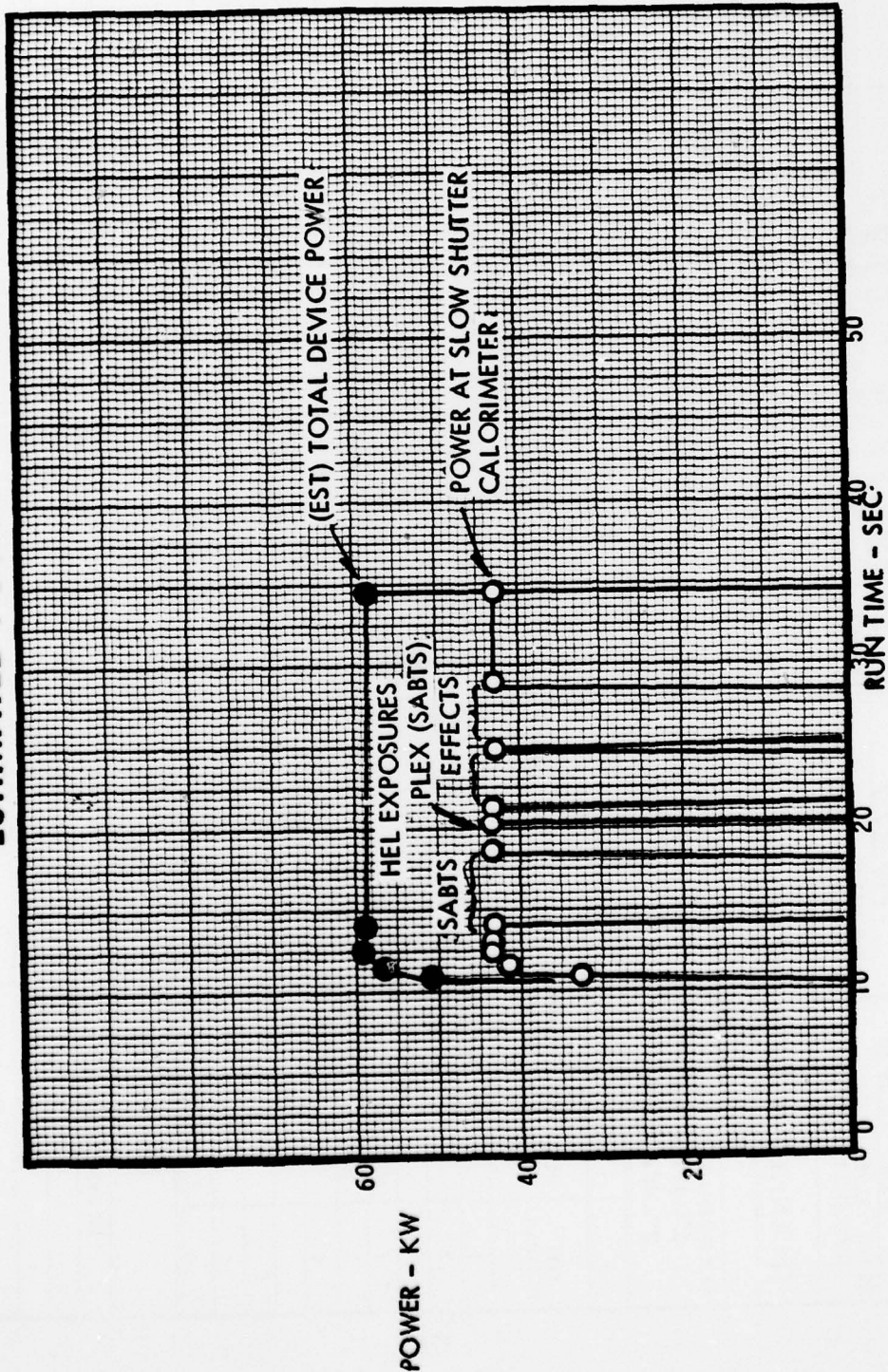

REMARKS:

PREPARED BY:

*V. SINGS*  
3-2-77

**PLANNED TIME LINES AND QUICK LOOK DATA SHEET**

**QUICK LOOK TEST DATA**

TEST PLAN <b>VLI-286</b>	DATE <b>2-28-77</b>	TIME <b>2333</b>
D2 FIRE VALVE OPEN (SEC) <b>9.9</b>	LASING DURATION (SEC) <b>34.5</b>	TOTAL COMPLETED TEST POSITIONS <b>4</b>
D2 FIRE VALVE CLOSED (SEC) <b>34.5</b>		PLANNED TOTAL PWR. <b>59</b>

PLANNED TEST NO. **0E21/NG** / TIME LINES AS OF DATE **2-28-77** REVISION **0E16**

EXPERIMENTER <b>D. MULLON</b>	PLANNED LINEAR MAGNIFICATION <b>3.1</b>	CONFIGURATION <input checked="" type="checkbox"/> REFLECTIVE <input type="checkbox"/> TRANSMISSIVE
<b>T. ROZMART</b>	PLANNED PEAK PWR DENSITY <b>~25 KW/CM<sup>2</sup></b>	

TEST POSITION	SPECIMEN NO.	COATING DESIGN	PLANNED				ACTUAL				COMMENTS	
			EXPOSURE TIME (SEC)	TRANSIT TIME (POST EXPOSURE)	TIME FROM F <sub>2</sub>	TIME SLICE	EST. PWR. AT TARGET	TOTAL POWER	ACTUAL SPOT DIAMETER			
1	#	HUGHES	4.0	1.70	14.00	13.5						
2		PLEXI	0.1	4.00	19.70					59.7		
3												
4	SPANI		3.0	1.10	23.80							
5	NGI	45° TEST	3.0		27.90							
6					30.90					59.3		

ITEM	START (SEC)	STOP (SEC)	ITEM	START (SEC)	STOP (SEC)
TV CAMERA No. 1	ON		O-GRAPI	MAN.	MAN.
" No. 2	"		SANGAMO No. 1	6.0	37.0
" No. 3	"		MOVIE CAMERA	23.0	35.0
" No. 4	"		SABTS SEQ.	N/A	
GULLOTTINE SABTS INST.	END OF 4		CALORIMETER (SABTS)	14.0	19.7
EFFECT MIRROR	END OF 2		CALORIMETER (SLOW SHUTTER)	10.0	14.0
HI FLOW ISLAND	10.0	25.0	" " " "	19.8	23.8
* PROFILER			" " " "	30.9	35.0

LASER PERFORMANCE ANALYSIS, RUN VLI-286

BEAM INTENSITY PROFILE

AS SEEN BY IR CAMERA VIEWING SECOND TURN FLAT

TOTAL INTENSITY  
APPROX. TIME (SEC) 20

LINEAR PROFILE\*  
APPROX. TIME (SEC) N/A



LEE BERGERSON  
BEAM DIAGNOSTICS ENGINEER

LASER PERFORMANCE ANALYSIS - RUN NUMBER VL 1-287

### ESTIMATED POWER VS. TIME

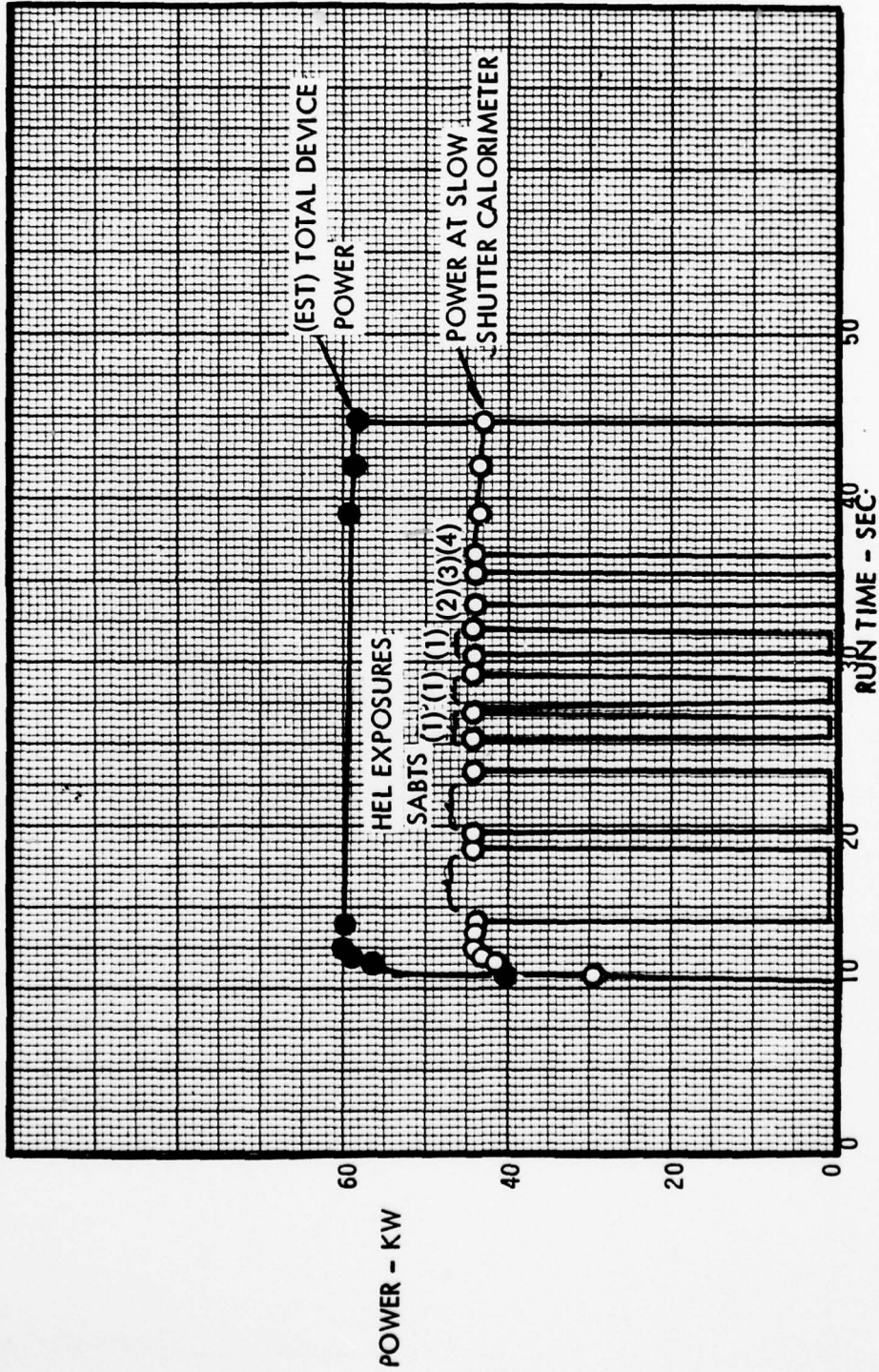

REMARKS: (1) SABTS OVERRIDE

(2) SABTS PLEX BURN

(3) EFFECTS EXPOSURE BALL CAL

(4) EFFECTS EXPOSURE NC2

PREPARED BY:

*J. STALS*

**PLANNED TIME LINES AND QUICK LOOK DATA SHEET**

QUICK LOOK TEST DATA	
RUN NO. <b>YL-287</b>	TEST PLAN <b>SABITS</b>
D2 FIRE VALVE OPEN (SEC) <b>9.9</b>	D2 FIRE VALVE CLOSED (SEC) <b>44.7</b>
DATE <b>3-1-77</b>	TIME <b>0224</b>
LASING DURATION (SEC) <b>34.8</b>	TOTAL COMPLETED TEST POSITIONS <b>59</b>
PLANNED TEST NO. <b>0E22/MG/TIME LINES</b> AS OF DATE <b>2-28-77</b> REVISION <b>0R16</b>	

EXPERIMENTER <b>D. MULLEN</b>	PLANNED LINEAR MAGNIFICATION <b>3.1</b>	CONFIGURATION <input checked="" type="checkbox"/> REFLECTIVE <input checked="" type="checkbox"/> TRANSMISSIVE
PLANNED PEAK PWR DENSITY <b>≈ 25 KW/CM<sup>2</sup></b>		

TEST POSITION	SPECIMEN NO.	COATING DESIGN	EXPOSURE TIME (SEC)	TRANSIT TIME (POST EXPOSURE)	TIME FROM F <sub>2</sub>	TIME SLICE	EST. PWR. AT TARGET	TOTAL POWER	ACTUAL SPOT DIAMETER	COMMENTS
1.	* DOP 6 (R)		4.0	1.70	14.00	13.5		60.0		
2.	DOP 5 (R)		4.0	1.70	17.70					
3	ZnSe 30 (T)		4.0	1.70	25.40					
4	SrF <sub>2</sub> 30 (T)		4.0	1.70	31.10					
5	* OCL 23 (T)		4.0	1.70	36.80					
6	PLEXI		0.1	1.10	42.50	43.2		59.1		
7										
8	BALCON		3.0	1.10	43.70					
9	AG 1 45° TEST		3.0		47.80					
10					50.80					

ITEM	START (SEC)	STOP (SEC)	ITEM	START (SEC)	STOP (SEC)
TV CAMERA No. 1	ON		O-GRAPH	MAN	MAN
No. 2	"		SANGAMO No. 1	6.0	52.0
No. 3	"		SANGAMO No. 2	N/A	
No. 4	"		SABITS SEC.	N/A	
GUILLOTINE SABITS INST.	END OF 8		CALORIMETER (SABITS)	14.0	42.5
REFLECT MIRROR	END OF 6		CALORIMETER (SLOW SHUTTER)	10.0	14.0
HI FLOW ISOLATION	10.0	55.0	"	50.9	55.0
* PROFILER			MAIN CAMERA	42.0	55.0

LASER PERFORMANCE ANALYSIS, RUN VLI-287

BEAM INTENSITY PROFILE

AS SEEN BY IR CAMERA VIEWING SECOND TURN FLAT

TOTAL INTENSITY  
APPROX. TIME (SEC) N/A

LINEAR PROFILE\*  
APPROX. TIME (SEC) N/A

NO DATA - BDL TIMER TIMED OUT  
DIGITAL RECORDER