

AD-A068 508

COLD REGIONS RESEARCH AND ENGINEERING LAB HANOVER NH F/G 13/2  
A LANDSAT DATA COLLECTION PLATFORM AT DEVIL CANYON SITE, UPPER --ETC(U)  
FEB 79 R K HAUGEN, R L TUINTRA  
CRREL-SR-79-2

NL

UNCLASSIFIED

1 OF 1  
AD  
A068508

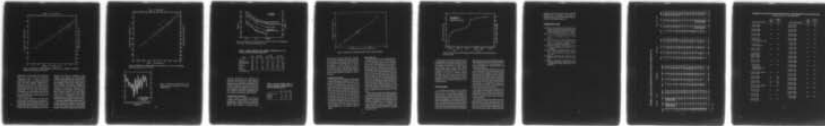

END  
DATE  
FILMED  
6 --79  
DDC

**LEVEL II**

12  
NW

Special Report 79-2

February 1979

**AD A068508**

**A LANDSAT DATA COLLECTION  
PLATFORM AT DEVIL CANYON SITE  
UPPER SUSITNA BASIN, ALASKA**

Performance and Analysis of Data

DDC  
MAY 11 1979  
C

R.K. Haugen, R.L. Tuinstra and C.W. Slaughter

DDC FILE COPY



UNITED STATES ARMY  
CORPS OF ENGINEERS  
COLD REGIONS RESEARCH AND ENGINEERING LABORATORY  
HANOVER, NEW HAMPSHIRE, U.S.A.



Approved for public release. distribution unlimited.

79 05 10 061

Unclassified

SECURITY CLASSIFICATION OF THIS PAGE (When Data Entered)

REPORT DOCUMENTATION PAGE		READ INSTRUCTIONS BEFORE COMPLETING FORM	
1. REPORT NUMBER Special Report 79-2	2. GOVT ACCESSION NO.	3. RECIPIENT'S CATALOG NUMBER	
4. TITLE (and Subtitle) A LANDSAT DATA COLLECTION PLATFORM AT DEVIL CANYON SITE, UPPER SUSITNA BASIN, ALASKA Performance and Analysis of Data		5. TYPE OF REPORT & PERIOD COVERED	
7. AUTHOR(s) R.K. Haugen, R.L. Tuinstra and C.W. Slaughter		6. PERFORMING ORG. REPORT NUMBER	
9. PERFORMING ORGANIZATION NAME AND ADDRESS U.S. Army Cold Regions Research and Engineering Laboratory Hanover, New Hampshire 03755		8. CONTRACT OR GRANT NUMBER(s) 9 Special rept.	
11. CONTROLLING OFFICE NAME AND ADDRESS Directorate of Civil Works Office, Chief of Engineers Washington, D.C.		10. PROGRAM ELEMENT, PROJECT, TASK AREA & WORK UNIT NUMBERS CWIS 3111 12/20p.	
14. MONITORING AGENCY NAME & ADDRESS (if different from Controlling Office) 10 Richard K. /Haugen, Ray L. /Tuinstra Charles W. /Slaughter		12. REPORT DATE 1 February 1979	
		13. NUMBER OF PAGES 19	
		15. SECURITY CLASS. (of this report) Unclassified	
16. DISTRIBUTION STATEMENT (of this Report) Approved for public release; distribution unlimited.		15a. DECLASSIFICATION/DOWNGRADING SCHEDULE	
		14 CRREL-SR-79-2	
17. DISTRIBUTION STATEMENT (of the abstract entered in Block 20, if different from Report)			
18. SUPPLEMENTARY NOTES This study was cooperatively supported by the U.S. Army Engineer District, Alaska, under DA Project <i>Environmental Quality/Environmental Impact: Subprogram, Environmental Resource Enhancement and Problem Management.</i>			
19. KEY WORDS (Continue on reverse side if necessary and identify by block number) Data collection platform Environmental data South central Alaska Landsat data			
20. ABSTRACT (Continue on reverse side if necessary and identify by block number) In October 1974, a Landsat Data Collection Platform was installed near the prospective Devil Canyon damsite on the Susitna River, south central Alaska. The development of sensor interfaces and characteristics of transmitted data for air and ground surface temperature, windspeed and wind run, water equivalent snow accumulation, and battery voltage are discussed. Temperature data are analyzed statistically and compared with data from surrounding National Weather Service stations. Although some difficulties were encountered in operation during the winter of 1974-75, it was demonstrated that the Landsat data collection system could provide useful environmental data from a remote, subarctic location in the winter on a near-real-time basis.			

DD FORM 1 JAN 73 1473

EDITION OF 1 NOV 68 IS OBSOLETE

037100

Unclassified

JOB

SECURITY CLASSIFICATION OF THIS PAGE (When Data Entered)

## **PREFACE**

This report was prepared by Richard K. Haugen, Geographer, Earth Sciences Branch, Ray L. Tuinstra, formerly Electrical Engineer, Technical Services Division, and Dr. Charles W. Slaughter, formerly Hydrologist, Alaskan Projects Office, U.S. Army Cold Regions Research and Engineering Laboratory.

The studies described in this report were cooperatively supported by the U.S. Army Engineer District, Alaska, under DA Project *Environmental Quality/Environmental Impact: Subprogram, Environmental Resource Enhancement and Problem Management*; and the Corps of Engineers Civil Works Project 3111, *Environmental Criteria for Resources Management in Cold Regions*.

The planning leading to the Data Collection Platform (DCP) installation at Devil Canyon was done by Dr. H.L. McKim of CRREL and Dr. D.M. Anderson (formerly of CRREL), who also participated in the administration of the project and in the field. Gary Flightner and Tim Renschler of the U.S. Army Engineer District, Alaska, provided considerable assistance in obtaining transportation and equipment needed to instrument the Devil Canyon site. Arthur Crook and Bert Clifford of the Soil Conservation Service, Anchorage, provided assistance in the installation of the snow pillow used in this study. Technical assistance was also provided by the CRREL Alaskan Projects Office.

Many individuals at CRREL provided support. Carolyn Merry handled the processing of the DCP data, Michael Hutton reduced the Stevens Recorder data, and Eleanor Huke did the illustrations. Michael Bilello reviewed an earlier draft, and Dr. J. Brown, Dr. H.L. McKim, L.W. Gatto and Ms. Merry reviewed the present manuscript.

The contents of this report are not to be used for advertising or promotional purposes. Citation of brand names does not constitute an official endorsement or approval of the use of such commercial products.

## CONTENTS

	Page
Abstract .....	i
Preface .....	ii
Introduction .....	1
Problem and approach .....	1
DCP interface systems .....	3
DCP and interface power supplies .....	4
Snow pillow interface .....	4
Air and ground surface temperature interface systems .....	6
Windspeed interface system .....	7
DCP system performance .....	7
Results and discussion .....	7
Air temperature data .....	7
Ground surface temperatures .....	11
Windspeed and passage .....	12
Snow pillow data .....	12
Conclusions .....	13
Literature cited .....	14
Appendix A: Adjusted air temperature data for Devil Canyon DCP .....	15
Appendix B: DCP snow pillow water equivalent measurements .....	17

## ILLUSTRATIONS

Figure	
1. The Susitna Basin and surrounding region .....	2
2. LANDSAT data relay system used for Devil Canyon DCP .....	4
3. Block diagrams of DCP interface systems .....	6
4. Relationship of 0900 temperature observations at Susitna Meadows to 0745-0915 temperature transmission of the DCP .....	8
5. Relationship of 0800 temperature observations at Talkeetna to 0745-0915 temperature transmissions of the DCP .....	9
6. Relationship of 0800 temperature observations at Summit to 0745-0900 temperature transmissions of the DCP .....	10
7. Adjusted and original DCP daily temperature data compared with Susitna Meadows data .....	10
8. Comparisons of maximum and minimum monthly air temperatures for October, November and December 1974 .....	11
9. Comparison of Stevens Recorder and DCP transmitted data .....	12
10. Snow pillow water equivalent data .....	13

## TABLES

1. NWS climatic stations in the vicinity of the Upper Susitna Basin .....	3
2. Typical computer printout of DCP data .....	5
3. Average maximum and minimum temperatures for selected stations, October-December 1974 .....	11
4. Average monthly values of DCP ground surface temperatures, October 1974-January 1975 .....	11

SESSION for	White Section <input checked="" type="checkbox"/>	Buff Section <input type="checkbox"/>	<input type="checkbox"/>
	ITS	DC	UNANNOUNCED JUSTIFICATION
BY	DISTRIBUTION/AVAILABILITY CODES		SPECIAL
			A

# A LANDSAT DATA COLLECTION PLATFORM AT DEVIL CANYON SITE, UPPER SUSITNA BASIN, ALASKA

## Performance and Analysis of Data

R.K. Haugen, R.L. Tuinstra and C.W. Slaughter

### INTRODUCTION

In Alaska, the major population concentrations center on Anchorage and Fairbanks and the "railbelt" connecting the two regions. The term railbelt derives from the Alaska Railroad that links Anchorage and Fairbanks. It is paralleled by the all-weather Anchorage-Fairbanks Highway. The Susitna River Basin offers an attractive potential hydroelectric power site (Fig. 1). Electrical power generated within this basin could readily be fed both north and south to serve roughly 75% of Alaska's population.

The U.S. Army Corps of Engineers has proposed a two-dam hydroelectric power generation system on the upper Susitna River. This system would comprise the Devil Canyon and Watana Dams (Fig. 1). These dams would have an installed power generation capacity of 6.9 billion kilowatt hours per year. The initial project cost estimate is \$1.52 billion. A summary of the proposed project and its environmental consequences is available in the 327-page "Revised Draft Environmental Impact Statement—Hydroelectric Power Development, Upper Susitna Basin, South-central Railbelt Area, Alaska" (Office of the Chief of Engineers 1975).

CRREL had acquired experience utilizing a Landsat (Land Satellite, formerly ERTS, the Earth Resources Technology Satellite, developed and operated by NASA) Data Collection System (DCS) for climatic and environmental data acquisition in Montana and New England (McKim et al. 1975). Based on that experience, the U.S. Army Engineer District, Alaska, and CRREL agreed to install a Landsat Data Collection Platform (DCP) and selected climatic sensors at the

proposed Devil Canyon Dam site (Anderson and McKim 1975).

The installation of a Landsat Data Collection Platform (DCP) near the Devil Canyon damsite provided an opportunity to evaluate its feasibility for use in a remote subarctic area. This report describes the DCP installation and development of electronic DCP-sensor interface devices to permit satellite transmission of data, and presents data obtained from the site during operation from 9 October 1974 to 26 May 1975.

### PROBLEM AND APPROACH

Climatic data for the Susitna River Basin are extremely scarce. Only two cooperative National Weather Service (NWS) stations, the Gracious House and Lake Louise, are within the basin. Talkeetna, 70 km to the southwest, and Summit, 60 km to the northwest, are the nearest first-order NWS stations to the Devil Canyon site. The NWS stations within and bordering the Susitna Basin are shown in Figure 1. Table 1 lists their elevations, geographic coordinates, and lengths of record. Because climatic data specific to the proposed damsites were lacking, it was necessary to devise a method for acquiring this information. Also, because access to the proposed Devil Canyon and Watana sites is at present limited to travel by helicopter, the acquisition of the climatic data by methods not requiring frequent site visits was considered necessary for economical reasons.

The Devil Canyon site was chosen for the DCP installation because it is the closest of the two prospective damsites to Talkeetna (which has

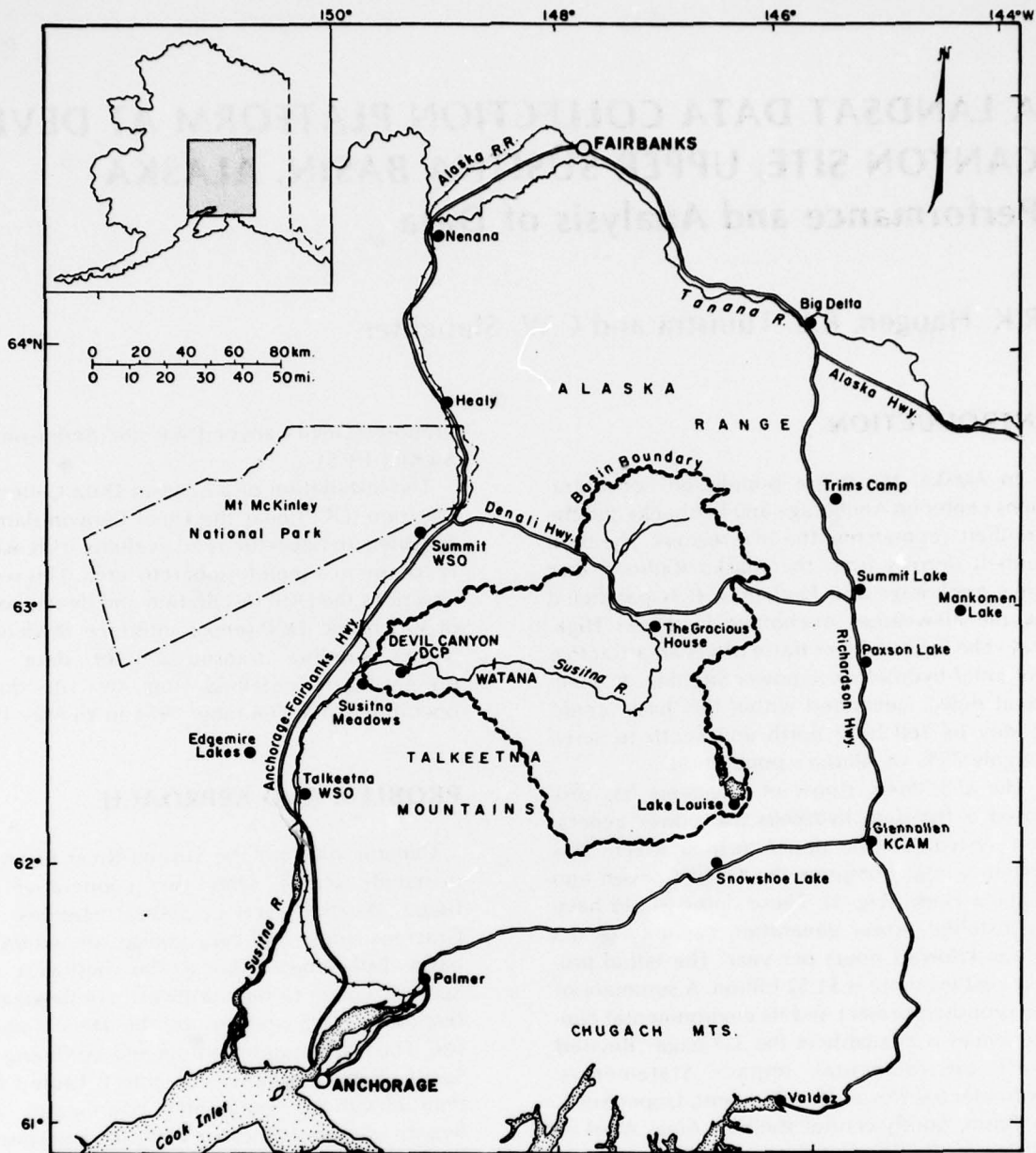

Figure 1. The Susitna Basin and surrounding region.

the nearest airport), and has an abandoned airstrip usable by helicopter and an old cabin for sheltering the DCP components. This DCP site is on a high, forested terrace above the proposed damsite at an elevation of 427 m. The geographic coordinates of the site are 62°48'58"N, 149°18'32"W.

The DCP was installed at the Devil Canyon site on 9 October 1974; this included installation of sensors for air and ground surface temperature, windspeed and total wind run. At this time, in addition, a helipad was cleared near the instrumentation site for future use. On 7 November, a second visit was made to install a

**Table 1. NWS (NOAA) climatic stations in the vicinity of the Upper Susitna Basin.**

Site	Elev (m)	Latitude	Longitude	Years of record* (through 1975)
Edgemire Lakes	232	62°32'	150°17'	4
Glennallen	444	62°07'	145°32'	9
Lake Louise	741	62°18'	146°35'	2
Mankomen Lake	922	62°59'	144°29'	10
Paxson Lake	838	62°57'	145°30'	7
Snowshoe Lake	735	62°02'	146°40'	12
Summit	732	63°20'	149°09'	32
Summit Lake	985	63°08'	145°32'	7
Susitna Meadowst	229	62°45'	149°42'	5
Talkeetna WSO	105	62°18'	150°06'	51
The Gracious House	777	63°08'	147°32'	11
Trims Camp	734	63°26'	145°46'	22

\*Data may be incomplete for some years.

†Discontinued March 1975.

snow pillow. On 9 April 1975, a third visit was made to change batteries, to adjust the snow pillow potentiometer,\* and to sample snowpack water equivalent for comparison with recorded and transmitted values. This report covers the DCP operational period ending 26 May 1975.

The transmission of data through the Landsat DCS is accomplished by a millivolt analog input from the sensors through the DCP to the Landsat satellite. The satellite transmits the signal to a ground station located at either Goldstone, California; Fairbanks, Alaska; or occasionally NASA Goddard Space Flight Center, Maryland. Messages received at Goldstone or Fairbanks are compiled and transmitted over NASA Communication System (NASCOM) ground lines to Goddard every two hours. The station at Goddard teletypes these messages directly to the U.S. Army Engineer Division, New England, at Waltham, Massachusetts, which in turn teletypes the messages to CRREL. The Goddard station also mails punched data cards directly to CRREL; these in practice are the data source generally used. However, when near-real-time data retrieval is desired, the teletype system is available. At CRREL, the DCP messages are converted by computer to engineering units and can be immediately transmitted to any user such as the Alaska District with teletype facilities. Figure

2 illustrates this data relay system. Further pertinent information about the data collection system is available in the NASA ERTS Data Users Handbook (NASA 1972).

A typical computer printout data sheet for the DCP-transmitted data is shown in Table 2. The following information is included:

1. Date: This is a Julian calendar date with the digit 4 (1974) or 5 (1975) preceding the day number of the year. Thus, 4365 would represent 31 December 74 or 51 would be 1 January 75.
2. Time: 24-hour clock, Alaskan Standard Time.
3. Air temperature, degrees Celsius: A thermistor is located in a standard weather shelter at 1.5-m height.
4. Ground surface temperature, degrees centigrade: A thermistor is located at the interface between the moss ground cover and the mineral soil.
5. Battery voltage: Voltage of the main DCP power supply provides information on when batteries need replacement.
6. Snow pillow: Water equivalent of the snowpack in inches.
7. Wind passage: Miles of wind passage since last data point.
8. Windspeed: Average windspeed in miles per hour since last data point.

## DCP INTERFACE SYSTEMS

The sensor interface systems for the Landsat DCP installed at Devil Canyon were developed

\*Site visits for installation and servicing were made by:  
R. Tuinstra, C. Slaughter, W. Hobgood—9 October 1974  
C. Slaughter, J. Rizor—7 November 1974  
D. Anderson, A. Crook—8 April 1975

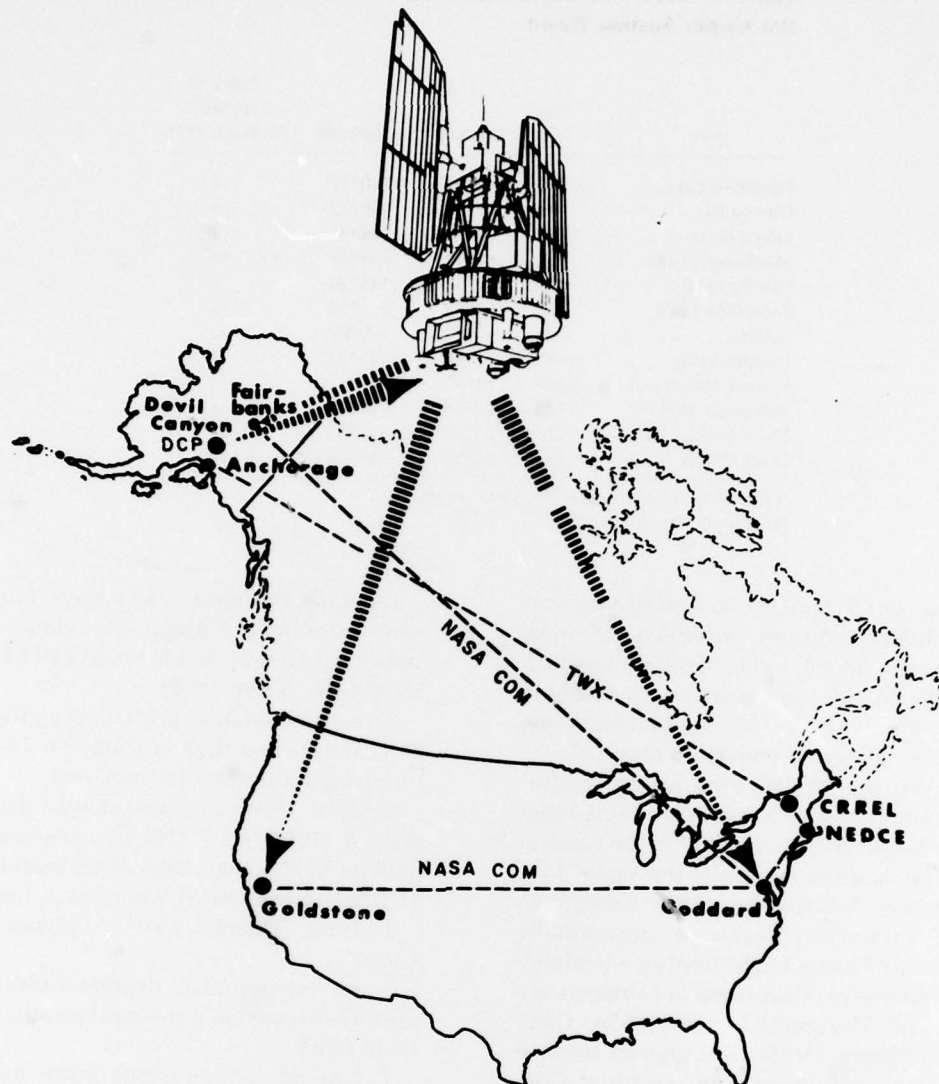

Figure 2. LANDSAT data relay system used for Devil Canyon DCP.

by the Technical Services Division, CRREL. In these system designs, the primary objective was to develop circuitry and mechanisms that would provide for long-term, unattended systems operation throughout a wide range of ambient temperatures. Block diagrams representing these systems are shown in Figure 3.

#### DCP and interface power supplies

The battery packs were designed for a six-month life. All batteries were a 6-V, 7.5-amp hr, gelled electrolyte, lead acid type, manufactured by Globe Union. Four of these batteries are connected in series to provide 24 V to power the

DCP. A 12-V tap from each battery set powered the snow pillow interface. Power is also fed to a voltage divider which reduces the 24 V to a level compatible with the 0-5 V analog DCP input. This is done to monitor the battery pack, and is printed as "Battery Voltage" in the DCP computer printout (Table 2). All other interfaces operate from a separate pack of four 6-V batteries connected in parallel, with a total capacity of 30 amp hr.

#### Snow pillow interface

The sensing element for this interface is a standard 8-ft (2.4-m)-diameter snow pillow. It is

Table 2. Typical computer printout of DCP data.

		DEVIL CANYON ALASKA							
	DATE	TIME	AIR TEMP C	GROUND TEMP C	BATTERY VOLT	SNOW PILLOW IN.	WIND PASSAGE KI	SPEED MPH	
Mar.	4	563	834	-6.6	-2.7	16.0	30.48	20.0	0.1
		563	836	-6.2	-2.7	16.0	30.99	0.8	12.0
	5	564	843	-9.8	-2.7	15.7	30.82	60.0	2.8
	6	565	847	-14.1	-2.7	16.0	30.82	62.4	2.6
		565	1849	-9.3	-2.9	16.0	31.25	28.8	2.1
	7	566	851	-9.8	-2.9	16.0	30.99	15.2	1.1
		567	857	-5.4	-2.7	16.0	30.53	72.8	3.0
	8	567	900	-5.6	-2.7	16.0	30.53	0.0	0.0
		567	1856	-8.7	-3.1	16.0	30.67	46.0	4.8
	9	568	904	-12.3	-2.9	16.0	31.10	20.8	1.5
		568	907	-11.5	-2.9	16.0	30.62	6.0	0.0
		568	1905	-9.4	-2.9	16.0	30.76	44.8	4.5
	10	569	910	-6.7	-2.7	16.0	30.25	38.4	2.7
		569	1910	-6.2	-2.1	16.0	30.62	41.6	4.2
	11	570	913	-7.3	-3.1	16.0	30.93	14.4	1.0
		570	917	-6.9	-2.9	16.0	30.93	0.0	0.0
		570	1914	-5.4	-2.9	16.0	31.20	12.0	1.3
		570	1917	-5.2	-2.9	16.0	30.93	0.0	0.0
	12	571	922	-6.2	-2.5	15.7	30.23	16.0	1.1
		571	1923	-6.5	-2.7	15.7	32.44	27.2	2.7
	13	572	926	-8.9	-2.9	16.0	30.23	15.2	1.1
		572	1925	-10.6	-2.9	15.7	29.96	36.0	3.6
		572	1928	-10.3	-2.9	15.7	31.20	0.0	0.0
	14	573	1932	-10.5	-2.9	16.0	31.10	60.0	2.5
	15	574	1937	-6.4	-2.5	16.0	30.62	53.6	2.2
	16	575	1943	-10.5	-2.9	16.0	30.87	77.6	3.2

connected by pipe to a nearby standpipe and the entire system is filled with an antifreeze solution. This solution is a mixture of glycol, alcohol, and water with a specific gravity  $\approx 1.0$ . As the snow accumulates on the pillow, a pressure develops in the pillow causing an increase in fluid level in the standpipe which corresponds directly to the water equivalent value of the snow.

The fluid level in the standpipe is measured using a float attached to a chain which passes over a gear wheel to a counterweight. As the float rises or falls, the gear wheel, which is mounted on the shaft of a 10-turn precision potentiometer, turns and varies the analog voltage applied to the DCP. The total voltage across the potentiometer is also monitored on another analog input channel of the DCP. The

ratio of these two voltages is directly proportional to the number of revolutions of the gear wheel and, therefore, is also proportional to the fluid level in the standpipe. The technique of using the ratio of two voltages makes the interface independent of battery voltage variation and eliminates the need for a precision voltage regulator. The power from the battery is applied to the interface only when the DCP is transmitting by the use of power turn-on switch circuitry controlled by the "Data Gate" signal from the DCP. This makes it possible to operate the snow pillow interface from the DCP battery pack with no effective decrease in battery life due to the added load.

The system as it is presently installed is designed to indicate a 25-in. (63.5-cm) range of level change. The gear wheel has a 6.25-in.

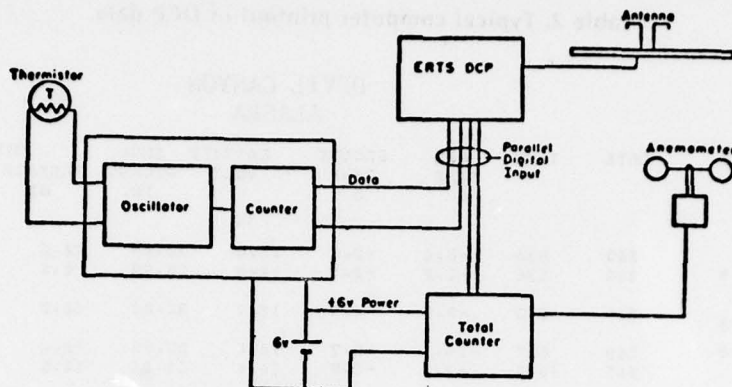

a. Temperature and wind passage interface.

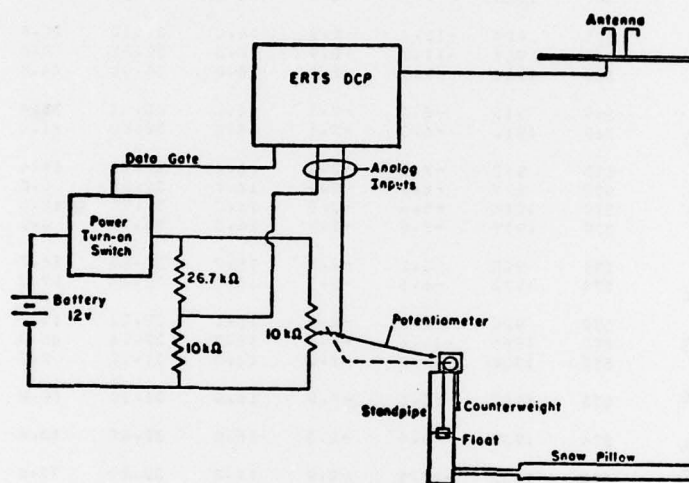

b. Snow pillow interface.

Figure 3. Block diagrams of DCP interface systems.

(15.9-cm) circumference so that a 25-in. (63.5-cm) change in fluid causes four revolutions of the potentiometer. With the application of 12 V, four revolutions of the 10-turn potentiometer provide a 4.8-V signal from the wiper arm, which matches the 0 to 5-V input range of the DCP. During the snow pillow installation, on 7 November 1974, the potentiometer was inadvertently rotated more than four turns, resulting in a signal greater than 5 V to the DCP, which prevented the transmission of valid data. This was corrected on 9 April 1975 during the next site visit. A conventional water level recorder (Leupold Stevens A 71) was included in the initial installation to provide analog strip chart records of snowpack fluctuations.

#### Air and ground surface temperature interface systems

The thermistor temperature sensor contains a small amount of semiconductor material which undergoes a large change in electrical resistance with temperature variations. This resistance change is used to control the output frequency of an electronic oscillator. The temperature-dependent frequency is measured by a counter circuit from which the data are issued in the form of a parallel 8-bit binary number. The range of the temperature sensors is  $-35^{\circ}\text{C}$  to  $+35^{\circ}\text{C}$ . The resolution for each of the systems is  $0.2^{\circ}\text{C}$ . All the circuitry used in the thermistor interfaces is constructed of complementary metal oxide semiconductor (CMOS) integrated circuits. This

type of circuit has a very low power consumption and wide operating temperature range. All circuitry is independent of or compensated for changes in ambient temperature and normal variations in battery voltage over the expected life of the battery pack.

#### **Windspeed interface system**

The input to the windspeed interface system is provided by a rotary cup anemometer with a small reed switch that momentarily closes its contacts for each 0.16 km of wind passage. The windspeed interface circuit senses the contact closures, divides the number of closures by 8, and counts the result in an 8-stage binary counter. The counter resets to zero automatically after the maximum count of 244 is reached. The output of the counter is an 8-bit parallel binary number which is applied to the parallel digital input of the DCP. When the data are received at CRREL, each binary is compared with the previous reading by computer and the total wind passage since the last reading is printed. The average windspeed is also computed locally by dividing time elapsed between messages by wind passage.

#### **DCP SYSTEM PERFORMANCE**

Data transmissions ranged from 2 to 14/day with an average of 6/day. Transmissions occurred any time the Landsat satellite communicated with a ground station and a DCP at the same time. For the Devil Canyon DCP, the satellite could relay messages to the Goldstone, California, ground station between 0730 and 0930 and again between 1730 and 1900 on the same day. These transmissions began 9 October 1974. However, data were not received during 14-16 and 20-21 January 1975, because the satellite transmission was turned off during the launching of Landsat II. Three other gaps in transmissions were noted: 29 January-1 February, 5-6 February, and 12-16 February 1975. These gaps are attributed to low battery voltages, probably caused by intervals of extreme cold. No transmissions occurred after 18 February until 8 March when two days' data were received with relatively warm air temperatures of  $-8^{\circ}$  to  $-0.5^{\circ}\text{C}$ .

No further data were received until the batteries were replaced at the next site visit on 9 April. The DCP then transmitted data con-

tinuously until 26 May, when a wire leading to the antenna was broken. The problem of low battery voltage due to exposure to extreme cold has since been lessened with the use of a sealed, buried instrument container. The wire breakage problem was corrected by the encasement of all exposed wires in polyvinyl chloride tubing.

### **RESULTS AND DISCUSSION**

#### **Air temperature data**

The air temperature sensor functioned well throughout the entire evaluation period. However, because the 2 to 5 data transmissions per day did not permit sampling the warmest and coldest portions of the diurnal temperature cycle, true daily maximum and minimum temperature values were not obtained directly. Therefore, it was necessary to analyze and convert these data to establish estimated maximum and minimum values for the Devil Canyon DCP sites.

Weather records were obtained for the comparable period from the National Weather Service in Anchorage (cooperative stations), and from the National Climatic Center in Ashville, North Carolina (first order NWS stations). These data allowed comparison of DCP data with conventional data at approximately the same time of the day as the morning and late afternoon DCP data transmission times. The NWS climatic records for Talkeetna during this period indicate that temperatures were slightly warmer than normal and precipitation was near normal for October and November, but 1.5 cm less than normal for December. None of these departures appears to be sufficiently large to bias comparisons with DCP data.

Three NWS stations, Susitna Meadows, Talkeetna, and Summit, which form an elevation and latitudinal gradient with the Devil Canyon DCP site, were selected for comparison. These stations are within 120 km of each other, so that day-to-day temperature variations could be expected to be essentially parallel but differing in magnitude according to elevation and local microclimate. Inspection of the data indicates that this is the case.

Temperature observations are available for 0900 at Susitna Meadows and for 0800 at Talkeetna and Summit. These observations were compared with DCP temperatures transmitted between 0745 and 0920 on the same day. The

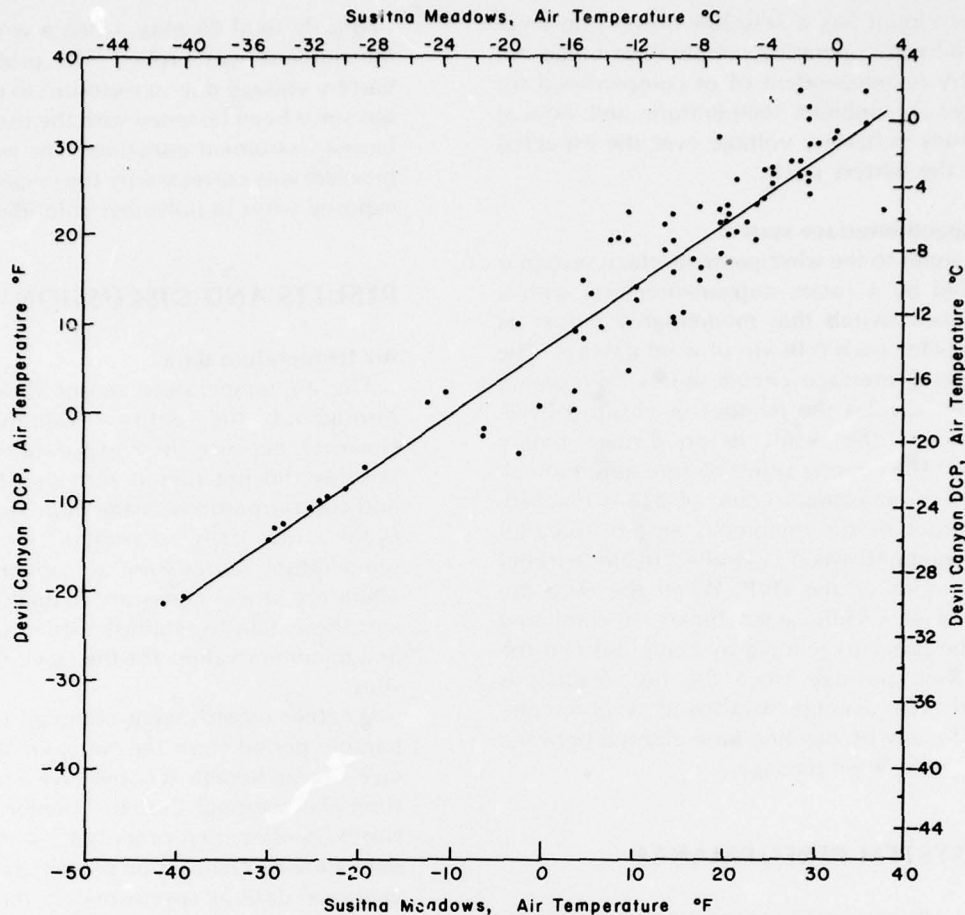

Figure 4. Relationship of 0900 temperature observations at Susitna Meadows to 0745-0915 temperature transmission of the DCP.

available records permitted comparison of samples of 60 data pairs from the DCP and Talkeetna and Summit, and of 80 data pairs from the DCP and Susitna Meadows.

Regression analysis of data from the Devil Canyon DCP and each of the three other stations indicated that the temperature relationships are essentially linear. Correlation analysis showed that the closest regression relationship was with Susitna Meadows, with a correlation coefficient ( $r$ ) of 0.94. The regression relationship is expressed as  $Y = -1.902 + 0.645X$ , where  $Y$  signifies Devil Canyon DCP temperature, and  $X$ , Susitna Meadows temperature, °C. This relationship is illustrated in Figure 4.

Regression relationships between the DCP and the more distant stations, Talkeetna and Summit, are shown in Figures 5 and 6. Representative correlation coefficients ( $r$ ) are 0.92 between the

DCP and Talkeetna and 0.86 between the DCP and Summit. The simple regression equations are, respectively,  $Y = -3.88 + 0.664X$  and  $Y = 0.4161 + 0.777X$  for these relationships. Based on the present sample, air temperatures for the DCP Canyon site can be estimated within the range of  $-43$  to  $+2^{\circ}\text{C}$ , with a standard error of estimate of  $2.2^{\circ}\text{C}$ .

The regression relationship between Susitna Meadows and the DCP site was used to provide estimated daily maximum and minimum temperatures representative of the Devil Canyon location. A daily listing of these data for the period 9 October 1974 through 31 January 1975 is included as Appendix A. A graphic comparison of corrected and uncorrected DCP temperature data is shown in Figure 7. It can be seen that on some days, especially those with small diurnal temperature ranges, the maximum and minimum

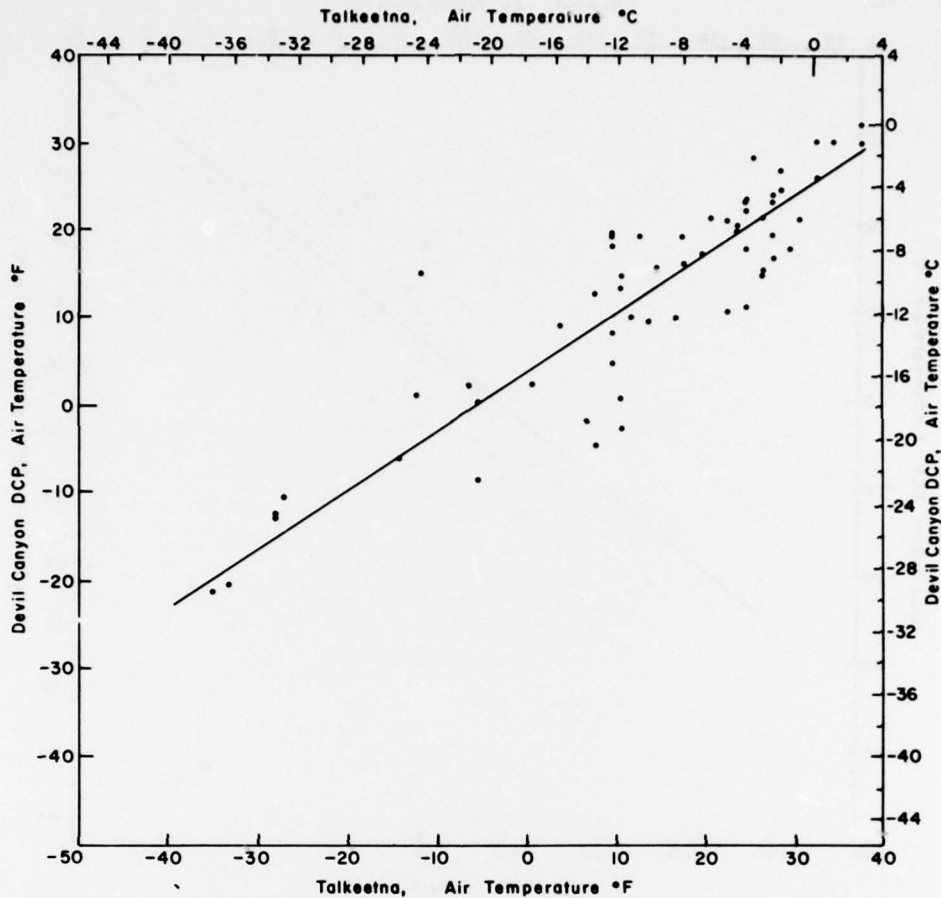

Figure 5. Relationship of 0800 temperature observations at Talkeetna to 0745-0915 temperature transmissions of the DCP.

temperatures as transmitted by the DCP are about the same as Susitna Meadows temperatures, but on days with large temperature ranges a considerable difference exists. The daily maximum temperatures as transmitted by the DCP are usually in closer agreement with the actual or estimated maximum temperatures than are the daily minimum temperatures. In most cases, the maximum temperature occurs around 1400, which is closer to a transmission time than in the case for minimum temperatures, which usually occur shortly before sunrise.

The average maximum and minimum temperatures, according to the estimation procedure, along with comparable values for surrounding NWS stations are listed in Table 3. The average maximum temperatures for the Devil Canyon DCP appear reasonable based on com-

parisons with those for Talkeetna, Susitna Meadows, and Summit. The average daily minimum values appear high in relation to those for the other stations, but this could be due to the topographic effects found at these stations. Both Talkeetna and Susitna Meadows are located in valleys, and are subject to nighttime temperature inversions resulting from downslope cold air drainage. The local height of these inversions appears to be usually below that of the DCP site on the terrace above Devil Canyon. This is suggested by the warmer estimated minimum values for the Devil Canyon DCP and by the topographic setting of the DCP.

Temperature relationships between these stations are illustrated in Figure 8. The estimated average maximum and minimum temperatures for the DCP parallel those of both Susitna Meadows and Summit for the three months. The

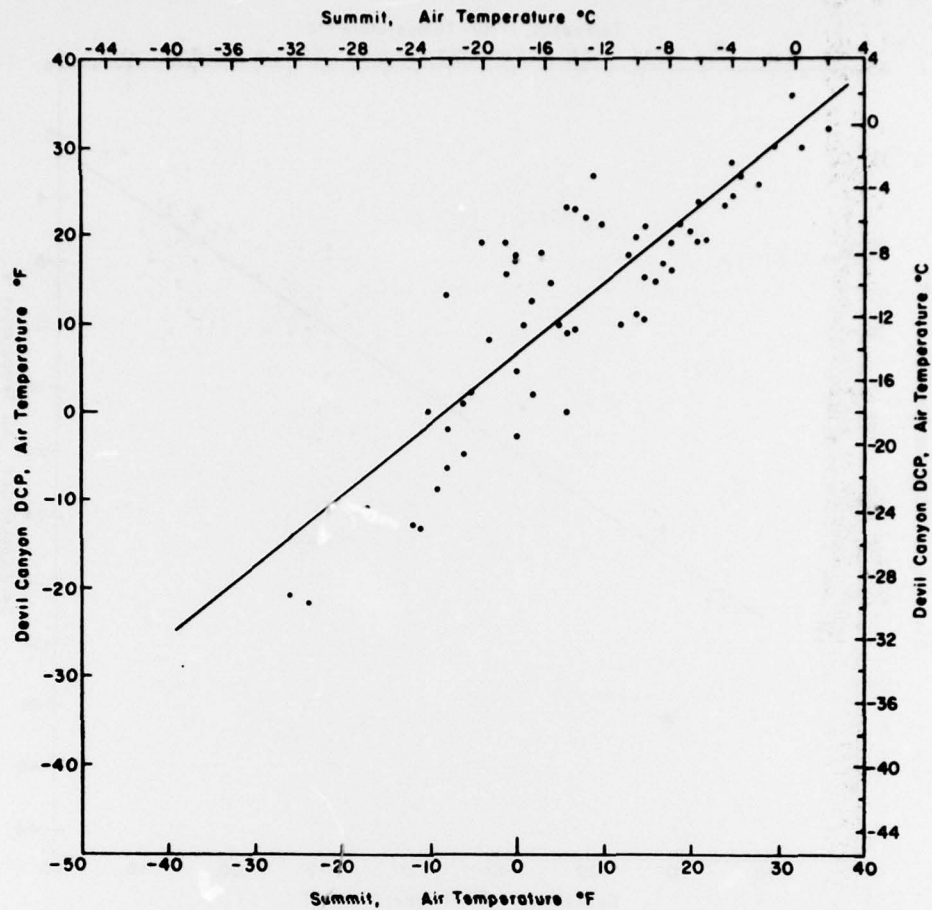

Figure 6. Relationship of 0800 temperature observations at Summit to 0745-0900 temperature transmissions of the DCP.

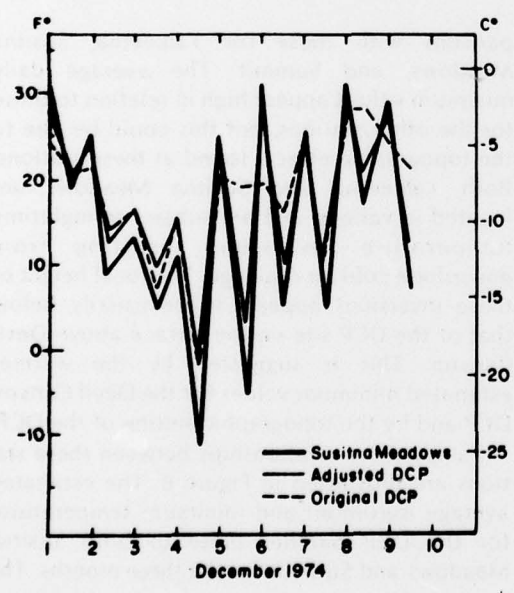

Figure 7. Adjusted and original DCP daily temperature data compared with Susitna Meadows data.

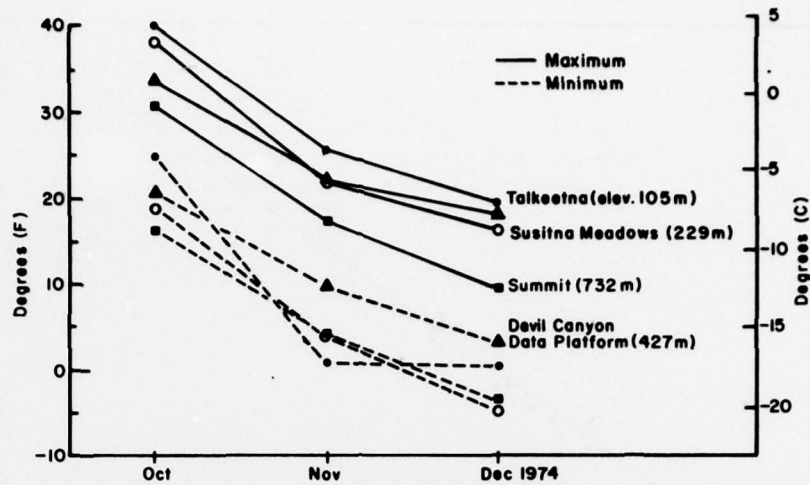

Figure 8. Comparisons of maximum and minimum monthly air temperatures for October, November and December 1974.

Table 3. Average maximum and minimum temperatures (°C) for selected stations, October-December 1974.

Station	Elev (m)	October*		November		December	
		Max	Min	Max	Min	Max	Min
Talkeetna	105	4.5	-3.6	-3.5	-17.2	-6.9	-17.3
Susitna Meadows	229	3.6	-6.7	-5.2	-15.3	-8.7	-20.3
Devil Canyon DCP	427	1.0	-6.3	-5.2	-12.3	-7.7	-16.1
Summit	732	—	—	-8.2	-15.6	-12.5	-20.1
Trims Camp	734	0.0	-7.4	-5.5	-15.5	-10.6	-19.9
Paxson	838	3.8	-6.8	-9.5	-17.2	-11.1	-21.4
Glennallen	444	3.7	-5.4	-6.5	-18.6	-14.1	-23.4

\*9-31 October only.

minimum temperatures at Talkeetna for November deviate from this pattern. Figure 8 shows that the temperature range (difference between the average maximum and minimum) at the DCP is most similar to that at Summit. Summit, like the DCP site, appears to have less frequent nighttime temperature inversions because of its elevation and relative topographic position, so that its temperature range is smaller.

#### Ground surface temperatures

Table 4 gives a summary of maximum, minimum, and average daily ground surface temperatures. Ground surface was below the freezing point during the entire observation period. The variation of ground surface

Table 4. Average monthly values of DCP ground surface temperatures (°C), October 1974-January 1975.

	Max	Min	Mean
October (9-31 only)	-1.5	-2.9	-2.2
November	-2.1	-2.4	-2.3
December	-2.0	-2.1	-2.1
January	-2.1	-2.2	-2.2

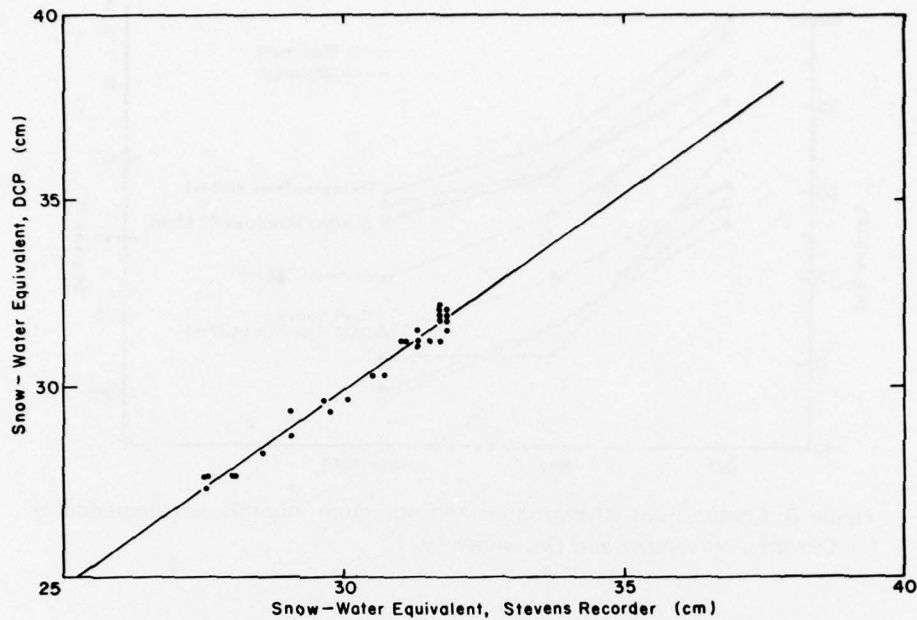

Figure 9. Comparison of Stevens Recorder and DCP transmitted data.

temperatures, on both a daily and a monthly basis, is small compared with the fluctuation of air temperatures. During the period of record, the maximum value recorded was  $-0.9^{\circ}\text{C}$  and the minimum  $-5.6^{\circ}\text{C}$ . Because the diurnal temperature range at the ground surface is small, the absence of nighttime data transmissions for this parameter is not serious and the ground surface record of the DCP is usable as received.

#### Windspeed and passage

Wind data were transmitted intermittently throughout the period considered in this report, October 1974 through May 1975. Previous experience has indicated that virtually all wind measuring instruments operate erratically in the *subarctic or arctic* winter during periods of extreme cold and rime ice formation. The intermittent failures in this instance were probably due to rime ice formation which immobilized the anemometer cups. Also, one cup was found to be twisted on the April site visit. The date the cup became twisted (sometime between the 11 November and 9 April site visits) is not apparent from the data. However, except for the occasional stoppages, this sensor provided data during all transmissions. An example is shown in Table 2.

#### Snow pillow data

Snow pillow data were received during the entire reporting period and in all DCP transmissions. The transmitted data were not representative of the water equivalent of the snowpack, however, due to an inadvertent initial error in the potentiometer setting during installation. Although this setting was corrected during a site visit, in April 1975, a leak developed in the snow pillow so that the transmitted data remained unrepresentative of the snowpack. However, the leak was small, and the snow pillow gradually lost its fluid charge over a 30-day period. During this time, it was possible to compare transmitted data with those recorded by the Stevens recorder (Fig. 9). These data correlated at  $r = 0.99$ , indicating virtually complete agreement, and serve to demonstrate the utility of the DCP system despite the initial potentiometer setting error.

Water equivalent data from the snow pillow, as measured by the Stevens recorder during the period 7 November 1974-7 April 1975, are shown graphically in Figure 10, and are tabulated in Appendix B. The measured water equivalent of the snowpack totaled 28.2 cm on 7 April 1975. The water equivalent value of multiple snow samples taken around the periphery of the snow pillow on the same date was 28.5 cm, verifying recorded values.

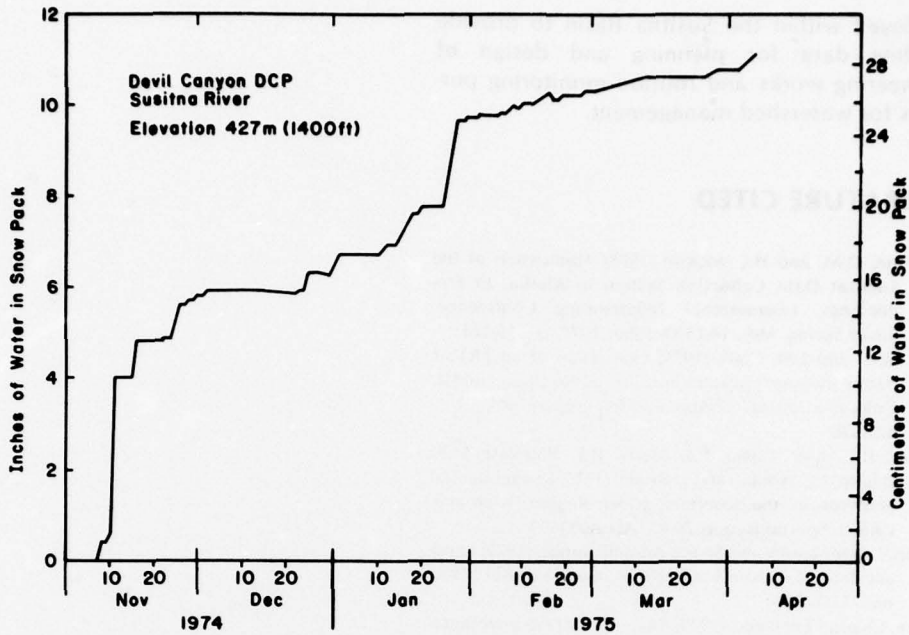

Figure 10. Snow pillow water equivalent data (as published by Soil Conservation Service, May 1975).

Comparisons were made between the DCP snow pillow data and snowpack values obtained from NWS climatic stations at Talkeetna, Susitna Meadows, and Summit. The Devil Canyon data compare most closely with Susitna Meadows data during November, with 14.7 cm at the Devil Canyon site, 12.9 cm at Susitna Meadows, and 7.6 cm at Talkeetna. During December, the Devil Canyon site received 4.1 cm water equivalent snowfall, which is greater than that at either Susitna Meadows (2.3 cm) or Talkeetna (2.9 cm). Summit received 41.2 cm during December.

## CONCLUSIONS

It is believed that the Devil Canyon Landsat DCP was the first installation operated for climatic data at a remote site during winter in Alaska. However, a similar DCP installation was operated during 1973-74 in an alpine tundra setting at Niwot Ridge in Colorado (Barry and Clark 1975). The CRREL DCP system functioned well in spite of several difficulties involved in installation of the DCP. The sensors functioned according to their design, and provided environmental data from a remote location which it would have

been difficult to obtain with other techniques. The daily data transmissions of the DCP offer obvious advantages for such phenomena as snowpack characteristics during the winter and runoff in the spring.

The period of operation (9 October 1974 to 26 May 1975) reported here was primarily during winter conditions. It appears that the statistical approach to the estimation of DCP maximum and minimum temperatures does not work with sufficient accuracy during warmer temperatures at the Devil Canyon site. The Susitna Meadows NWS station was discontinued in March 1975, and attempts to correlate DCP temperatures with those from more distant stations during the warmer weather were not successful.

The range of snowfall values obtained at the Devil Canyon site in comparison with that from nearby NWS stations indicates the importance of obtaining more data at the Devil Canyon site as well as at other locations within the Upper Susitna watershed.

A variety of sensors can be interfaced with the DCP in addition to those examined in this report. CRREL has successfully interfaced sensors for water pH, dissolved oxygen, conductivity, and river stage with the Landsat DCP (McKim et al. 1975). Many of these sensors could be profitably

employed within the Susitna Basin to provide baseline data for planning and design of engineering works and routine monitoring purposes for watershed management.

## LITERATURE CITED

- Anderson, D.M. and H.L. McKim (1975) Application of the Landsat Data Collection System in Alaska. In *Proceedings, International Telemetry Conference*, Silver Spring, Md., 14-15 October 1975, p. 315-323.
- Barry, R.G. and J.M. Clark (1975) Evaluation of an ERTS-1 data collection platform installed in the alpine tundra, Colorado. *Journal of Applied Meteorology*, vol. 14, p. 622-626.
- McKim, H.L., L.W. Gatto, C.J. Merry, B.E. Brockett, M.A. Bilello, J.E. Hobbie and J. Brown (1975) Environmental analyses in the Kootenai River Region, Montana. CRREL Special Report 76-13. AD A033599.
- National Aeronautics and Space Administration (1972) Landsat data users handbook. NASA, Goddard, Md., Doc. no. 715D4249.
- Office, Chief of Engineers (1975) Revised draft environmental impact statement—Hydroelectric Power Development, Upper Susitna Basin, South-central Railbelt area, Alaska.
- U.S. Department of Agriculture, Soil Conservation Service (1975) Snow surveys and water outlook for Alaska, May.
- U.S. Department of Commerce, National Oceanic and Atmospheric Administration Environmental Data Service (1974-1975) Monthly climatic data, Alaska, Asheville, N.C.



**APPENDIX B. DCP SNOW PILLOW WATER EQUIVALENT MEASUREMENTS (from Stevens Recorder)**  
**Begin Record 1530—7 November 1974**

<i>Inclusive dates and times</i>	<i>This snowfall (cm)</i>	<i>Cumulative total (cm)</i>	<i>Inclusive dates and times</i>	<i>This snowfall (cm)</i>	<i>Cumulative total (cm)</i>
7 Nov 74, 1730	1.0	1.0	20 Jan 75, 0245	0.4	19.7
8 Nov 74, 0230			20 Jan 75, 1715		
9 Nov 74, 1900	.51	1.5	25 Jan 75, 1145	4.7	24.4
10 Nov 74, 0500			28 Jan 75, 1945		
10 Nov 74, 1130	8.6	10.1	28 Jan 75, 2145	0.1	24.5
11 Nov 74, 0430			29 Jan 75, 0300		
15 Nov 74, 1130	2.0	12.2	30 Jan 75, 0740	0.1	24.6
16 Nov 74, 0130 (incremental jumps noted)			30 Jan 75, 0940		
22 Nov 74, 0745 (incremental jump)	0.1	12.3	2 Feb 75, 1245	0.1	24.8
			2 Feb 75, 1615		
24 Nov 74, 1920	1.9	14.2	6 Feb 75, 1615	0.1	24.9
26 Nov 74, 0830			7 Feb 75, 2315		
27 Nov 74, 0230			9 Feb 75, 0045	0.3	25.1
27 Nov 74, 1500	0.3	14.5	9 Feb 75, 1745		
28 Nov 74, 0840			10 Feb 75, 1700	0.1	25.3
28 Nov 74, 1940			10 Feb 75, 1900		
29 Nov 74, 2345	0.3	14.7	11 Feb 75, 0900	-0.1	25.1
30 Nov 74, 1015			11 Feb 75, 1000		
1 Dec 74, 2030	0.3	15.0	12 Feb 75, 0030	0.3	25.4
2 Dec 74, 1030 (+ 8 Dec 74 0700 incre- mental jump)			13 Feb 75, 0415		
			14 Feb 75, 1745	0.6	26.0
14 Dec 74 (melt or ablation)	-0.1	14.9	18 Feb 75, 1630		
22 Dec 74, 2030			19 Feb 75, 1815	0.4	25.4
			21 Feb 75, 0620		
22 Dec 74, 2030	0.1	15.0	21 Feb 75, 0620	0.3	25.9
23 Dec 74, 0430	0.1	15.0	21 Feb 75, 2020		
24 Dec 74, 0500	1.0	16.0	25 Feb 75, 1240	0.3	26.2
25 Dec 74, 1815	1.0	16.0	27 Feb 75, 0045		
27 Dec 74 (melt or ablation)	-0.1	15.9	28 Feb 75, 2030	0.8	26.9
30 Dec 74, 1600			12 Mar 75, 2345		
30 Dec 74, 1600	1.1	17.0	25 Mar 75, 2300	0.4	27.3
1 Jan 75, 0730			28 Mar 75, 2300		
10 Jan 74, 2230	0.5	17.5	3 Apr 75, 0600	0.9	28.2
12 Jan 75, 1430			7 Apr 75, 1030		
15 Jan 75, 0430	1.8	19.3			
18 Jan 75, 2100					