

UNCLASSIFIED

MAR 28 1980

AEDC-TSR-78-V25

AUG 2 1980

AUGUST 1978

UN 03 1998

0.2

DOC_NUM SER CN
UNC28854-PDC A 1



HEAT-TRANSFER, SURFACE-PRESSURE, AND BOUNDARY-LAYER SURVEYS ON CONIC AND BICONIC BODIES WITH BOUNDARY-LAYER TRIPS AT MACH NUMBER 6 - PHASE II

Frederick K. Hube
ARO, Inc., AEDC Division
A Sverdrup Corporation Company
von Kármán Gas Dynamics Facility
Arnold Air Force Station, Tennessee

Period Covered: April 13, 17, and 18, 1978

Approved for public release; distribution unlimited.

Reviewed by:

ERVIN P. JASKOLSKI, Capt. USAF
Test Director, VKF Division
Directorate of Test Operations

Approved for Publication
FOR THE COMMANDER

ALAN L. DEVEREAUX
Colonel, USAF
Deputy for Operations

Prepared for: Space and Missile Systems Organization
RSSE, P. O. Box 92960
Worldway Postal Center
Los Angeles, California 90009

ARNOLD ENGINEERING DEVELOPMENT CENTER
AIR FORCE SYSTEMS COMMAND
ARNOLD AIR FORCE STATION, TENNESSEE

UNCLASSIFIED

Library of U. S. Air Force
AEDC DIVISION
1978-04-03



UNCLASSIFIED

REPORT DOCUMENTATION PAGE		READ INSTRUCTIONS BEFORE COMPLETING FORM										
1. REPORT NUMBER AEDC-TSR-78-V25	2. GOVY ACCESSION NO.	3. RECIPIENT'S CATALOG NUMBER										
4. TITLE (and Subtitle) Heat Transfer, Surface Pressure, and Boundary-Layer Surveys on Conic and Biconic Bodies with Boundary-Layer Trips at Mach 6 - Phase II	5. TYPE OF REPORT & PERIOD COVERED Final Report April 13, 17-18, 1978											
	6. PERFORMING ORG. REPORT NUMBER											
7. AUTHOR(s) Frederick K. Hube, ARO, Inc., a Sverdrup Corporation Company	8. CONTRACT OR GRANT NUMBER(s)											
9. PERFORMING ORGANIZATION NAME AND ADDRESS Arnold Engineering Development Center Air Force Systems Command Arnold Air Force Station, Tennessee 37389	10. PROGRAM ELEMENT, PROJECT, TASK AREA & WORK UNIT NUMBERS Program Element 63311F											
11. CONTROLLING OFFICE NAME AND ADDRESS SAMSO/RSSE P. O. Box 92960, Worldway Postal Center Los Angeles, Calif. 90009	12. REPORT DATE July 1978											
	13. NUMBER OF PAGES 68											
14. MONITORING AGENCY NAME & ADDRESS (if different from Controlling Office)	15. SECURITY CLASS. (of this report) Unclassified											
	15a. DECLASSIFICATION/DOWNGRADING SCHEDULE N/A											
16. DISTRIBUTION STATEMENT (of this Report) Approved for public release; distribution unlimited.												
17. DISTRIBUTION STATEMENT (of the abstract entered in Block 20, if different from Report)												
18. SUPPLEMENTARY NOTES Available in DDC.												
19. KEY WORDS (Continue on reverse side if necessary and identify by block number) <table style="width: 100%; border: none;"> <tr> <td style="width: 50%;">boundary-layers</td> <td style="width: 50%;">transition</td> </tr> <tr> <td>hypersonic flow</td> <td>heat-transfer</td> </tr> <tr> <td>boundary layer trips</td> <td>pressure distribution</td> </tr> <tr> <td>conic bodies</td> <td></td> </tr> <tr> <td>biconic bodies</td> <td></td> </tr> </table>			boundary-layers	transition	hypersonic flow	heat-transfer	boundary layer trips	pressure distribution	conic bodies		biconic bodies	
boundary-layers	transition											
hypersonic flow	heat-transfer											
boundary layer trips	pressure distribution											
conic bodies												
biconic bodies												
20. ABSTRACT (Continue on reverse side if necessary and identify by block number) Heat transfer, surface pressure, and boundary-layer surveys were obtained on a 7-deg cone as well as 10.5/7 deg and 14/7-deg biconic bodies. These data were obtained to determine the influence of boundary-layer trips on boundary-layer characteristics when compared with a naturally turbulent boundary layer. Flow field measurements included pitot-pressure, total temperature, and Preston tube data. Surveys were performed at several longitudinal stations along the bodies. Boundary-layer trips consisted of Carborundum® grit bonded to the nose tips or a single row of spherical elements. Data were obtained at a												

UNCLASSIFIED

UNCLASSIFIED

nominal Mach number of 6 at free-stream Reynolds numbers of 2.5×10^6 and 4.7×10^6 per ft. A variety of nose bluntness and trip combinations were tested at zero angle of attack.

AFSC
Arnold AFB Tex

UNCLASSIFIED

CONTENTS

	<u>Page</u>
NOMENCLATURE	3
1.0 INTRODUCTION	4
2.0 APPARATUS	
2.1 Test Facility	4
2.2 Test Article	5
2.3 Test Instrumentation	
2.3.1 Test Conditions	5
2.3.2 Test Data	6
2.3.3 Heat-Transfer Measurements	6
2.3.4 Flow-Field Measurements	6
2.4 Survey Probes	
2.4.1 Geometry Details	6
2.4.2 Calibration	7
2.5 Survey Mechanisms	7
3.0 TEST DESCRIPTION	
3.1 Test Conditions and Procedures	7
3.1.1 General	7
3.1.2 Data Acquisition	8
3.2 Data Reduction	9
3.3 Uncertainty of Measurements	
3.3.1 General	9
3.3.2 Test Conditions	9
3.3.3 Data Uncertainty	10
3.4 Data Corrections	10
4.0 DATA PACKAGE PRESENTATION	11
5.0 REFERENCES	11

APPENDIXES

I. ILLUSTRATIONS

Figure

1. Tunnel B	13
2. Model Geometry	14
3. Boundary-Layer Trip Geometry	15
4. Pitot Probe Geometry and Location	17
5. Unshielded Total Temperature Probe	19
6. Preston Tube Geometry	20
7. Schematic of Overhead Probe Installation	21
8. Schematic of On-Board Probe Installation	21
9. Probe Survey Locations	22

II. TABLES

Table

1. Surface Instrument Locations	24
2. Test Conditions and Configurations - Phase II	27

III. DATA REDUCTION

1.0 Surface Pressure Data	34
2.0 Heat Transfer Data	34
3.0 Probe Data	
3.1 Pitot Pressure	35
3.2 Unshielded Thermocouple Measurements	35
3.3 Preston Tube Data	37
4.0 Boundary-layer Integral Values	41

IV. SAMPLE DATA NOMENCLATURE AND FORMATS

Sample

1. Nomenclature: Surface Pressure Data	46
2. Sample Data: Surface Pressure Data	47
3. Nomenclature: Heat-Transfer Data	48
4. Sample Data: Heat-Transfer Data	50
5. Nomenclature: On-Board Probe Flow-Field Data	51
6. Sample Data: On-Board Probe Flow-Field Data	53
7. Nomenclature: Overhead Probe Flow-Field Data	60
8. Sample Data: Overhead Probe Flow-Field Data	63

NOMENCLATURE

$H(T_0)$	Heat transfer coefficient based on T_0 , BTU/ft ² -sec-°R
M_∞	Free-stream Mach number
P_0	Tunnel stilling chamber pressure, psia
P_∞	Free-stream static pressure, psia
q_∞	Free-stream dynamic pressure, psia
$Re_\infty, Re_\infty/ft$	Free-stream Reynolds number, ft ⁻¹
T_0	Tunnel stilling chamber temperature, °R
V_∞	Free-stream velocity, ft/sec
$X, XSURF$	Model surface distance, in.
α	Model angle of attack, deg
ϕ	Model roll angle, deg
ρ_∞	Free-stream density, slugs/ft ³
θ	Body surface angle, deg
ω	Circumferential location of pressure orifice and heat gages (positive clockwise looking upstream) deg

1.0 INTRODUCTION

The work reported herein was sponsored by the Space and Missile Systems Organization (SAMSO), Air Force Systems Command (AFSC) and the Research Division of the Directorate of Test Engineering (DOTR), of the Arnold Engineering Development Center (AEDC), AFSC, under Program Element 63311F, AF Control Number 627A-00-8. The work was performed by ARO, Inc., AEDC Division, (a Sverdrup Corporation Company), contract operator of AEDC, Arnold Air Force Station, Tennessee. Project monitors were Capt. R. J. Chambers and Mr. E. R. Thompson for SAMSO and AEDC, respectively. ARO project monitor and principal investigator was Dr. M. O. Varner. Inquiries to obtain copies of the test data should be directed to either of the following: SAMSO/RSSE, P. O. Box 92960, Worldway Postal Center, Los Angeles, CA 90009; AEDC/DOTR, Arnold AFS, TN 37389, Attn: Mr. E. R. Thompson. A copy of the final data is on file in microfilm at AEDC.

Tests were conducted in the 50-in. Hypersonic Wind Tunnel (B) of the von Karman Gas Dynamics Facility (VKF) on April 13, 17, and 18, 1978 under ARO Project Number V41B-W6. The objective of the test was to determine the influence of boundary-layer trips on the boundary-layer and flow-field characteristics when compared with naturally turbulent flows. This test phase (Phase II) utilized the basic boundary-layer trip results and instrumentation developed during Phase I which was documented in Ref. 1.

Heat-transfer data were obtained to determine transition locations. Corresponding wall pressures and temperatures as well as flow-field surveys were taken. Pitot probes, unshielded thermocouple probes, and a Preston tube were used to obtain flow-field data at each survey station. Most flow-field data were obtained with a probe system mounted in the top of the tunnel test section. However, a few runs were made with a sting mounted probe to obtain data at an aft survey station. Data were also obtained at the aft station with the overhead probe when the on-board probe had been removed to determine if the on-board probe assembly caused any interference with flow near the model base.

All data were obtained at a nominal Mach number of 6 at free-stream Reynolds numbers of 2.5×10^6 to 4.7×10^6 per ft and zero angle of attack. Body configurations tested included a 7-deg cone, a 10.5/7-deg biconic, and a 14/7-deg biconic. Spherically blunted nose tips with radii of 0.05 in. and 0.50 in. were tested. Only the 7-deg cone was tested with a sharp nose tip.

2.0 APPARATUS

2.1 TEST FACILITY

Tunnel B is a closed circuit hypersonic wind tunnel with a 50-in.-diam test section. Two axisymmetric contoured nozzles are available to provide Mach numbers of 6 and 8 and the tunnel may be operated continuously over a range of pressure levels from 20 to 300 psia at $M_\infty = 6$, and 50 to 900 psia at $M_\infty = 8$. Stagnation temperatures sufficient to avoid air liquefaction in the test section (up to 1350°R) are obtained through the use of a natural gas-fired combustion heater. The entire tunnel (throat, nozzle, test section, and diffuser) is cooled by integral,

external water jackets. The tunnel is equipped with a model injection system, which allows removal of the model from the test section while the tunnel remains in operation. The general arrangement of Tunnel B is illustrated in Fig. 1.

2.2 TEST ARTICLE

Three model configurations were tested:

<u>CONFIGURATION</u>	<u>FOREBODY HALF ANGLE, DEG</u>	<u>AFTERBODY HALF ANGLE, DEG</u>
CONE	7.0	7
BICONIC	10.5	↓
BICONIC	14.0	↓

These configurations were tested with spherically blunted nose tips with nose radii of 0.05 and 0.500 in. Data were also obtained on a sharp, 7-deg cone configuration. Overall geometry of the configurations tested is illustrated in Fig. 2. Model design and fabrication were performed at AEDC.

The models were instrumented with pressure orifices and Gardon-type heat-flux gages. Table 1 (Appendix 2) lists the instrumentation locations and shows that the top centerline was the primary ray of pressure instrumentation and the bottom centerline was the ray instrumented with Gardon gages. At three stations, pressure orifices were located at 90-deg intervals around the model. To minimize the possibility of orifice interference on the flow-field data, the model was rolled 10 degs to provide a clean run of smooth wall ahead of the probe station.

Boundary-layer trips consisted of distributed roughness formed by bonding Carborundum® grit to the model or by mounting a single row of spherical elements. The geometry and location of the trips are shown in Fig. 3.

2.3 TEST INSTRUMENTATION

2.3.1 Test Conditions

Tunnel B stilling chamber pressure is measured with a 200- or 1000-psid transducer referenced to a near vacuum. Based on periodic comparisons with secondary standards, the accuracy (a bandwidth which includes 95-percent of residuals, i.e. 2σ deviation) of the transducers is estimated to be within ± 0.25 percent of reading or ± 0.3 psi, whichever is greater for the 200-psid range and ± 0.25 percent of reading or ± 0.8 psi, whichever is greater for the 1000-psid range. Stilling chamber temperature measurements are made with Chromel®-Alumel® thermocouples which have an accuracy of $\pm(1.5^\circ\text{F} + 0.375$ percent of reading) based on repeat calibrations (2σ deviation).

2.3.2 Test Data

The Tunnel B pressure system is equipped with 1- and 15-psid transducers which are referenced to a near vacuum. The system automatically selects the transducers and calibrated ranges for best precision for each pressure measurement. Based on periodic comparisons with secondary standards, the accuracy of these transducers (bands that include 95 percent of the residuals i.e. 2σ deviation) is estimated to be ± 0.2 percent of reading or ± 0.01 psi, whichever is greater, for the 15-psid transducers and ± 0.2 percent of reading or ± 0.0015 psi, whichever is greater, for the 1-psid transducers.

2.3.3 Heat-Transfer Measurements

Heat-transfer data were obtained using 0.125-in. diam Gardon-type heat-flux gages with Iron-Constantan[®] case thermocouples. The case thermocouple served a dual role by providing a sensing disc edge temperature used in the evaluation of heat-transfer coefficient and indicating the model wall temperature level during long hot-wall runs. As an additional check on the long-term wall temperature, two co-ax heat gages were installed. No attempt was made to evaluate heat flux from the coax gages. Details of both types of gages used are available in Ref. 2.

2.3.4 Flow-Field Measurements

Two separate probing systems were used to perform the boundary layer and flow-field surveys. An overhead probe system which was the primary flow-field survey mechanism was instrumented with a pitot tube, unshielded thermocouple probe and a Preston tube. A second system was attached to the model support sting and was equipped with a pitot tube and an unshielded thermocouple probe. A Preston tube was included on the on-board probe installation, but pressure response from this probe was not satisfactory and data from this probe are not presented.

The unshielded thermocouple probes were made with Chromel-Alumel thermocouples which had an estimated uncertainty of $\pm(1.5^\circ\text{F} + 0.375$ percent of reading).

Both pitot probe pressures (on-board and overhead) and the overhead Preston tube were measured with 15-psid Druck[®] transducers which had an estimated measurement uncertainty of ± 0.009 psi. A near vacuum reference pressure was used with these transducers. The near vacuum reference pressure was measured with a Hastings absolute pressure transducer.

2.4 SURVEY PROBES

2.4.1 Geometry Details

Both the overhead and sting-mounted pitot probes were fabricated by flattening an 0.024-in. O.D. (0.020 I.D.) tube as shown in Fig. 4. This procedure produced a probe tip thickness of 0.020 in. with an open slit of 0.005 in. height.

Figure 5 illustrates the geometry of the unshielded total temperature probes. These probes were designed and fabricated by the VKF using a length of sheathed thermocouple wire (0.010-in. O.D.) with two 0.0015-in. diam wires. The wires were bared for a length of about 0.015 in. and the thermocouple junction formed. The probe was used in this form without any shield.

Preston tube geometry is illustrated in Fig. 6. The geometry is consistent with dimensions used by Bradshaw and Unsworth (Ref. 4) and therefore established the Preston tube calibration factors.

2.4.2 Calibration

The recovery temperature characteristics of each total temperature probe were calibrated in the inviscid portion of the model flow field and in the tunnel free-stream flow. Calibration data for the unshielded probes were expressed in the form of recovery factor as a function of Reynolds number.

2.5 SURVEY MECHANISMS

The overhead probe drive system illustrated in Fig. 7 was designed and fabricated by the VKF. The mechanism is housed above a port in the top of the Tunnel B test section. Access to the test section is through a 40-in.-long by 4-in.-wide opening which can be sealed by a pneumatically-operated door. Separate drive motors are provided to (1) insert the mechanism into the test section or retract it into the housing, (2) position the mechanism at any desired axial station over a range of 35-in. with a precision of ± 0.01 in., and (3) probe a flow field of approximately 10-in. depth with a precision of ± 0.001 in. The drive axis inclination of the probe support was adjusted to obtain surveys normal to the model surface. The strut is equipped with a pneumatically-operated shield to protect the probes during injection and retraction through the tunnel boundary layer and during tunnel condition changes.

The sting-mounted probe package shown in Fig. 8 was designed and fabricated by the VKF. A drive motor and position potentiometer were enclosed in an "L"-shaped sheet metal housing which had water tubes for cooling. The system has a vertical drive with a position resolution of ± 0.001 . Total vertical travel of the system is approximately 4 in.

3.0 TEST DESCRIPTION

3.1 TEST CONDITIONS AND PROCEDURES

3.1.1 General

A summary of nominal test conditions at each Mach number is given below:

M_∞	p_o , psia	T_o , °R	ρ_∞ , $\frac{\text{slugs}}{\text{ft}^3}$	V_∞ , ft/sec	p_∞ , psia	$Re_\infty/\text{ft} \times 10^{-6}$
5.94	131	845	7.06×10^{-5}	2982	0.088	2.5
5.95	250	845	13.37×10^{-5}	2983	0.167	4.7

Table 2 contains a summary of all configurations and test conditions.

The objective of this test phase was to evaluate the influence of boundary-layer trips on boundary-layer and flow-field characteristics. Flow-field surveys were performed at several longitudinal body stations on configurations with different nose tips and trip combinations. Corresponding heat-transfer data were obtained to identify transition and verify that turbulent flow existed at the probe survey stations. Figure 9 lists the survey station for each basic body configuration while Table 2 indicates the actual configurations and flow conditions surveyed.

3.1.2 Data Acquisition

Transition location was determined from heat-transfer distribution obtained with the Gardon heat-flux gages. Prior to each run the model was cooled to approximately 520°R by flowing air over the model. The model was injected into the tunnel flow for about five seconds while a continuous record of gage output was recorded. Data presented in the Data Package were reduced approximately one second after the model reached the centerline of the wind tunnel. Some runs were obtained with a hot wall to minimize the time required for a full cooling cycle. Since the thermal driving potential ($T_o - T_w$) was low for these cases, the data uncertainty was significantly greater than the cool wall data. However, these data were qualitatively useful in determining the presence of transition.

Surface-pressure distributions were obtained on selected configurations. It should be noted that surface pressure at each probe station was obtained each time a survey point was recorded. This procedure made it possible to confirm that local wall pressure had been obtained in the absence of any local probe disturbance or interference.

Initial probe positioning on the model wall was monitored with a (525 lines/frame) closed circuit television system (CCTV). The camera was fitted with a telescopic lens system which gave a magnification factor of approximately 7. The television image was used to monitor probe longitudinal location and to verify Preston tube and pitot probe contact with the model surface. At each survey station, a reference mark was painted on the model surface with black paint to provide an optical target for positioning the probe. The Preston tube and pitot tube were brought down until they both were in contact with the model surface. It is estimated that the probe was located axially to within ± 0.050 in. of the reference marks.

Initial data were obtained with the Preston tube and pitot tube in contact with the model surface. The first three probe positions above the model surface were obtained using manual probe drive control to achieve the desired small height increments between points. Remaining points in the survey were obtained using an automatic system which drove the probe to predetermined locations above the model surface.

At each location, data were automatically recorded after a delay time controlled by a timing circuit. The delay time was determined by observing the pitot pressure stabilization time at several points in the boundary layer. Note that the only point valid for the Preston tube measurement was the initial point at the model wall. Each survey consisted of approximately 50 points. Probe survey stations for each configuration are shown in Fig. 9.

3.2 DATA REDUCTION

Although some portions of the data reduction used in this study were fairly standard, the flow field survey probe data included an evaluation of several boundary layer parameters including the definition of the boundary layer thickness, displacement thickness, momentum thickness, kinetic energy thickness and total enthalpy thickness. Also special data reduction procedures were needed to correct the total temperature probe measurements and evaluate the Preston tube data. A complete summary of the data reduction procedures used in this study are given in Appendix III.

3.3 UNCERTAINTY OF MEASUREMENTS

3.3.1 General

The accuracy of the basic measurements (p_o and T_o) was discussed in Section 2.3. Based on repeat calibrations, these errors were found to be

$$\frac{\Delta p_o}{p_o} = 0.0025 = 0.25\%, \quad \frac{\Delta T_o}{T_o} = 0.005 = 0.5\%$$

Uncertainties in the tunnel free-stream parameters and the model aerodynamic coefficients were estimated using the Taylor series method of error propagation, Eq. (1),

$$(\Delta F)^2 = \left[\frac{\partial F}{\partial X_1} \Delta X_1 \right]^2 + \left[\frac{\partial F}{\partial X_2} \Delta X_2 \right]^2 + \left[\frac{\partial F}{\partial X_3} \Delta X_3 \right]^2 \dots + \left[\frac{\partial F}{\partial X_n} \Delta X_n \right]^2 \quad (1)$$

where ΔF is the absolute uncertainty in the dependent parameter $F = f(X_1, X_2, X_3 \dots X_n)$ and X_n are the independent parameters (or basic measurements). ΔX_n are the uncertainties (errors) in the independent measurements (or variables).

3.3.2 Test Conditions

The accuracy (based on 2σ deviation) of the basic tunnel parameters, p_o and T_o , (see Section 2.3) and the 2σ deviation in Mach number determined from test section flow calibrations were used to estimate uncertainties

In the other free-stream properties using Eq. (1). The computed uncertainties in the tunnel free-stream conditions are summarized in the following table.

		Uncertainty, (\pm) percent of actual value					
M_∞	$Re_\infty/\text{ft} \times 10^{-6}$	M_∞	P_∞	q_∞	Re_∞/ft	$\rho_\infty V_\infty$	ρ_∞
5.94	2.5	0.2	1.0	0.7	0.7	0.9	0.7
5.95	4.7	0.2	1.0	0.7	0.7	↓	↓

3.3.3 Test Data

Model surface pressure and on-board pitot probe data uncertainties are discussed in Section 2.3.2. Summarizing, measurements at pressure levels at 1 psia or less have an estimated uncertainty of ± 0.2 percent of reading or ± 0.0015 , whichever is greater. Measurements above 1 psia have an estimated uncertainty of ± 0.2 percent of reading or ± 0.01 psi, whichever is greater. Overhead pitot probe instrumentation is discussed in detail in Section 2.3.4 in which an estimated uncertainty of ± 0.009 psia in pitot pressure is stated.

Total temperature measurements from unshielded thermocouple probes is estimated to be $\pm(1.5^\circ\text{F} + 0.375$ percent of reading). Consequently, because data were obtained under hot-wall conditions (approximately adiabatic), the estimated uncertainty in the probe measurements throughout the flow field is ± 0.5 percent of temperature in $^\circ\text{R}$.

The estimated uncertainty in Gardon gage calibration factors is ± 5 percent. Overall uncertainty in the heat-transfer coefficient, $H(TO)$, is estimated to be ± 6 percent. After the uncertainties in free-stream of density and velocity are considered, the overall uncertainty in Stanton number is estimated to be ± 6.1 percent.

Based on optical observations and mechanical resolution the estimated uncertainty in probe position above the model is ± 0.002 in. Longitudinal probe position or station location is estimated to have an uncertainty of ± 0.050 in.

The uncertainties of all primary measurements such as pressure, temperature, heat flux rate, model attitude and free stream Mach number nonuniformity have been identified. The uncertainty in some of the free stream parameters have been identified, but the uncertainty in many of the other parameters (for example, the Preston tube data or boundary layer parameters) listed in the tabulated and plotted results of the final data fall outside the scope of this report.

3.4 DATA CORRECTIONS

The longitudinal heat-transfer distribution on the 7-deg cone showed more irregularity than expected based on the estimated uncertainty in the gage data. During the Phase I tests, a procedure was established to smooth the data by obtaining correction factors for the indicated heating level. The data distribution was compared with

calculated turbulent and laminar heating data. Based on these comparisons, smooth fairings through the data were obtained. A separate set of correction factors were obtained for laminar and turbulent cases since these cases represented the extremes in heating levels encountered. These two sets of correction factors were averaged and applied to the data. Correction factors were applied only to the 7-deg cone and the 7-deg conical afterbody. Data tabulations show both corrected and uncorrected data.

A correction for unshielded probe position was made to account for probe downward deflection resulting from aerodynamic loading. The deflection magnitude was determined from the television monitor screen and estimated to be 0.005 in.

Corrections were also made in the probe height position to account for initial pitot deflection caused by excessive pressure exerted when the probe came in contact with the model. In some cases, the pitot probe was sprung or preloaded enough that as the probe drive started to move the probe support away from the model, the pitot stayed in contact with the model. Consequently, the probe position readout indicated a probe position change which did not occur. Displacement of the velocity profiles yielded a position correction which minimized the effects of probe bending.

4.0 DATA PACKAGE PRESENTATION

A complete set of test results in tabulated and graphical form has been transmitted to SAMSO (test sponsor) as a Final Data Package. The data computational procedures were checked by performing manual calculation verification of the computer calculations. Sample tabulated data and nomenclature appear in Appendix IV.

5.0 REFERENCES

1. Hube, Frederick K. "Heat Transfer, Surface Pressure, and Boundary-Layer Surveys on Conic and Biconic Bodies with Boundary-Layer Trips at Mach Number 6 - Phase I." AEDC-TSR-78-V24, July, 1978.
2. Trimmer, L. L., Matthews, R. K. and Buchanan, T. D. "Measurement of Aerodynamic Heat Rates at the AEDC von Karman Facility," International Congress on Instrumentation in Aerospace Simulation Facilities IEEE Publication CHO 784-9 AES, September, 1973.
3. Robertson, S. James "On the Use of the Gardon Gage for the Measurement of Convective Heat Flux," Heat Technology Lab Memo 9, Huntsville, Alabama, June 1962.
4. Bradshaw, P. and Unsworth, K. "A Note on Preston Tube Calibrations in Compressible Flow," Imperial College Aero Report 73-07, London, England, September 1973.
5. Allen, Jerry M. "Reevaluation of Compressible-Flow Preston Tube Calibrations," NASA TM X-3488, February, 1977.

APPENDIX I

ILLUSTRATIONS

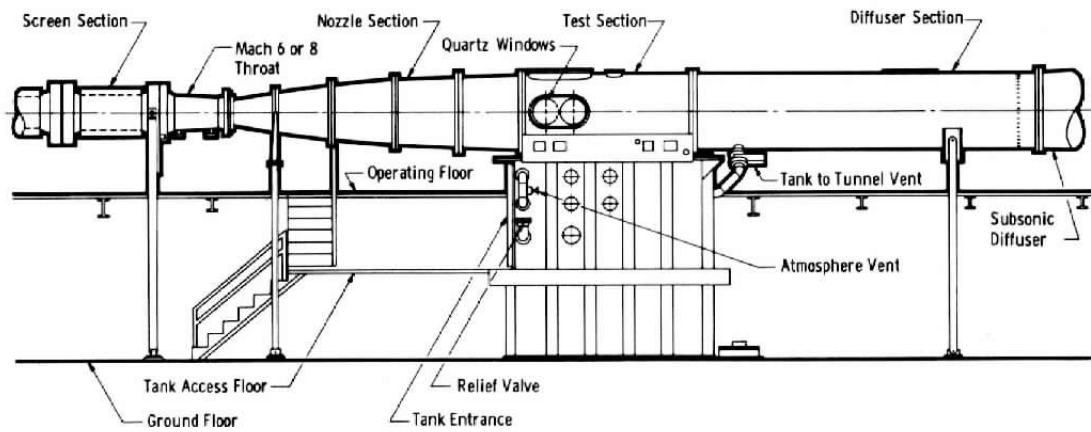

a. Tunnel assembly

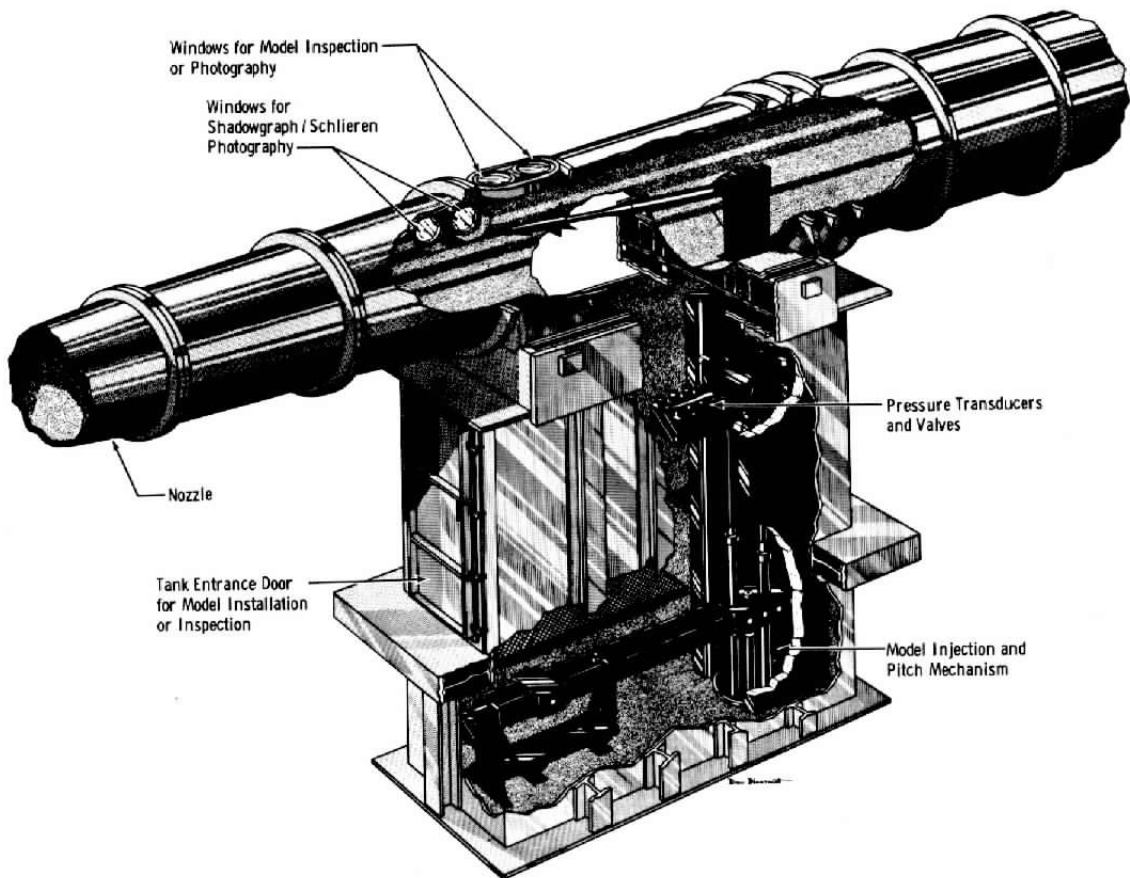

b. Tunnel test section
Fig. 1. Tunnel B

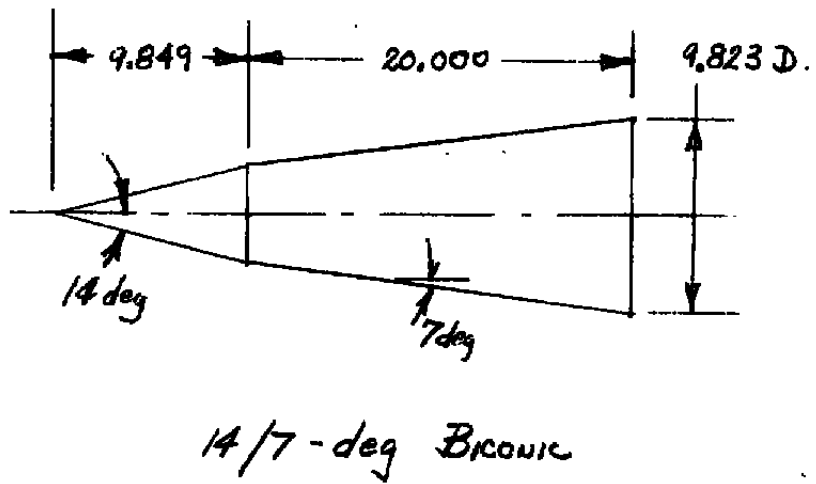
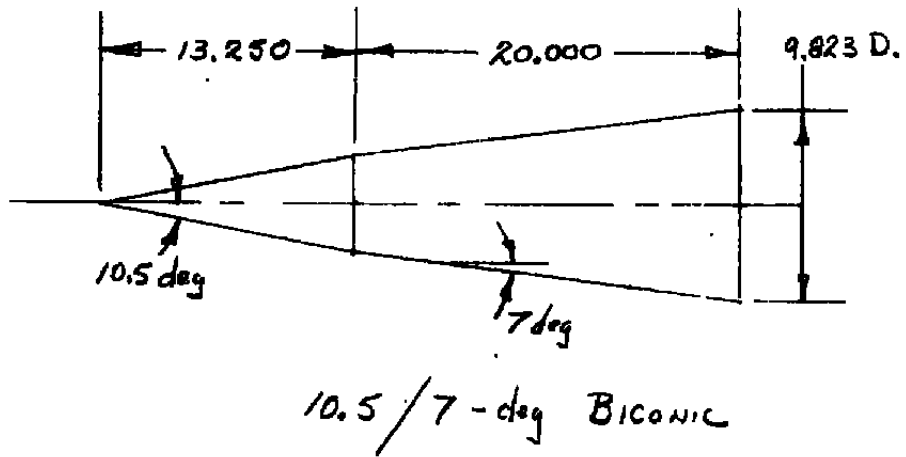
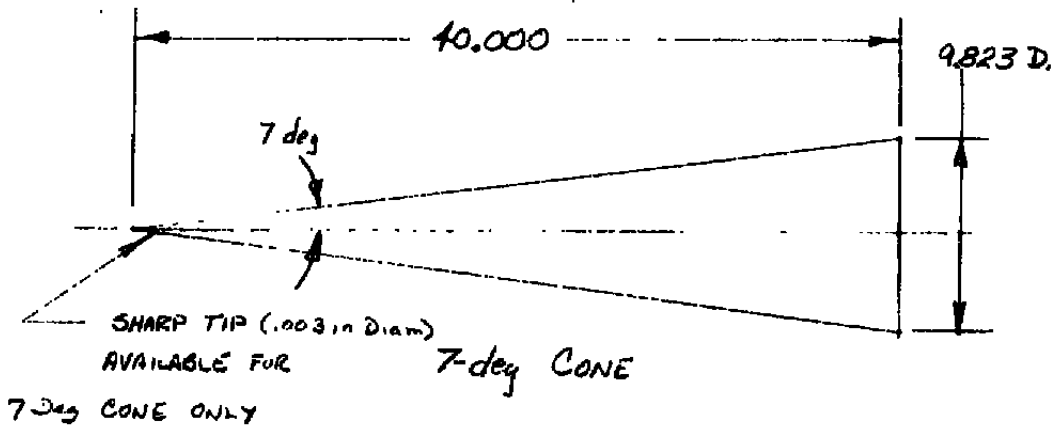

LINEAR DIMENSIONS IN INCHES.

Fig. 2 Model Geometry

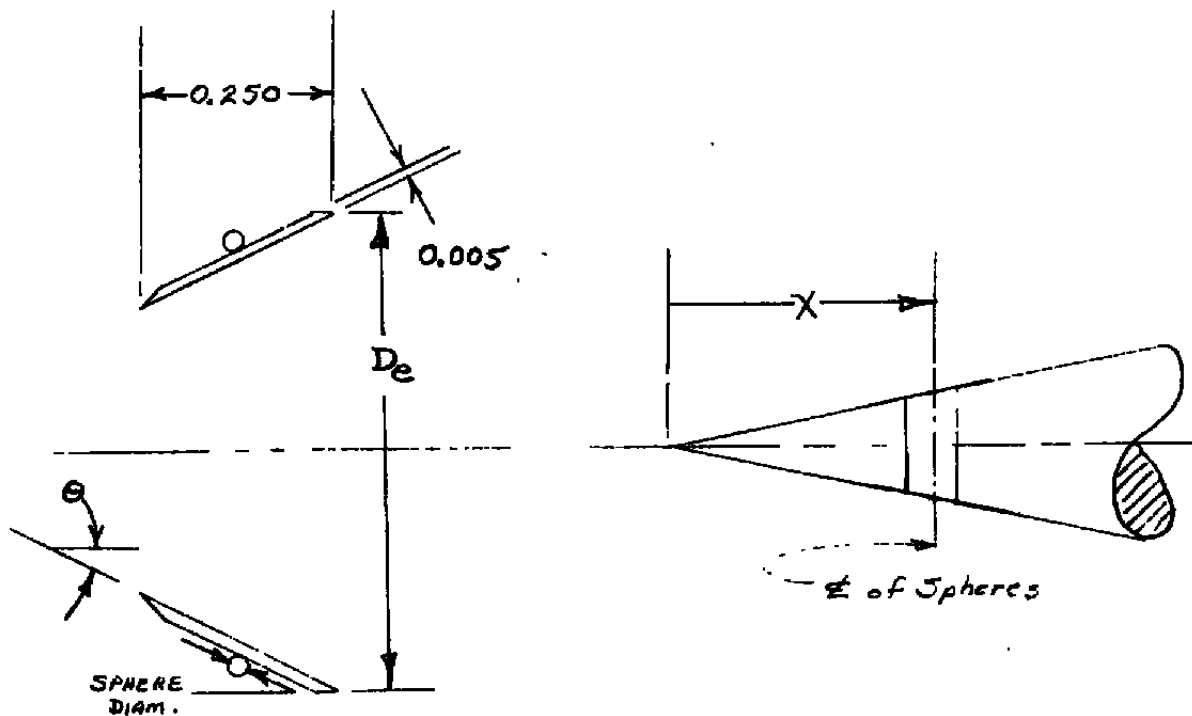

LINEAR DIMENSIONS IN INCHES.

θ , deg	X , IN	De , IN	SPHERE DIAM., IN	NO OF SPHERES
7	6.5	1.504	0.093	17
10.5	4.0	1.530	0.046	35
10.5	4.0	1.530	0.125	13
14	3.0	1.558	0.046	35
14	3.0	1.558	0.093	18

a. Spherical element trips

Fig. 3 Boundary-Layer Trip Geometry

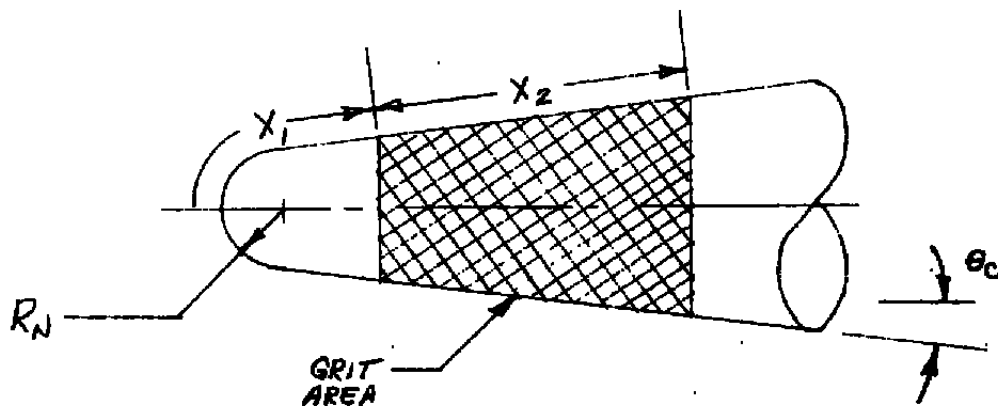

θ_c, in	R_N, in	X_1, in	X_2, in	GRIT No.	NOMINAL GRIT SIZE, IN
7	0.05	1.481	3.900	30	0.022
↓	0.50	1.571	0.800	46	0.014
10.5	0.05	1.352	2.700	60	0.010
↓	0.50	0.949	1.300	60	0.010
↓	0.50	0.949	1.300	30	0.022
14	0.05	1.069	2.000	60	0.010
↓	0.50	0.661	1.200	46	0.014

b. Distributed grit trips

Fig. 3 Concluded

STAINLESS STEEL TUBING	
O.D.	I.D.
0.093	0.064
0.062	0.042
0.040	0.025
0.024	0.020

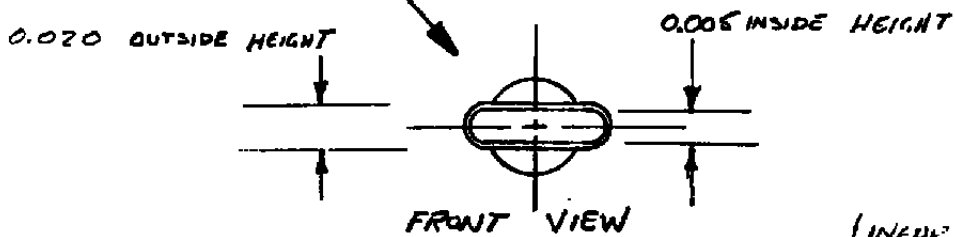
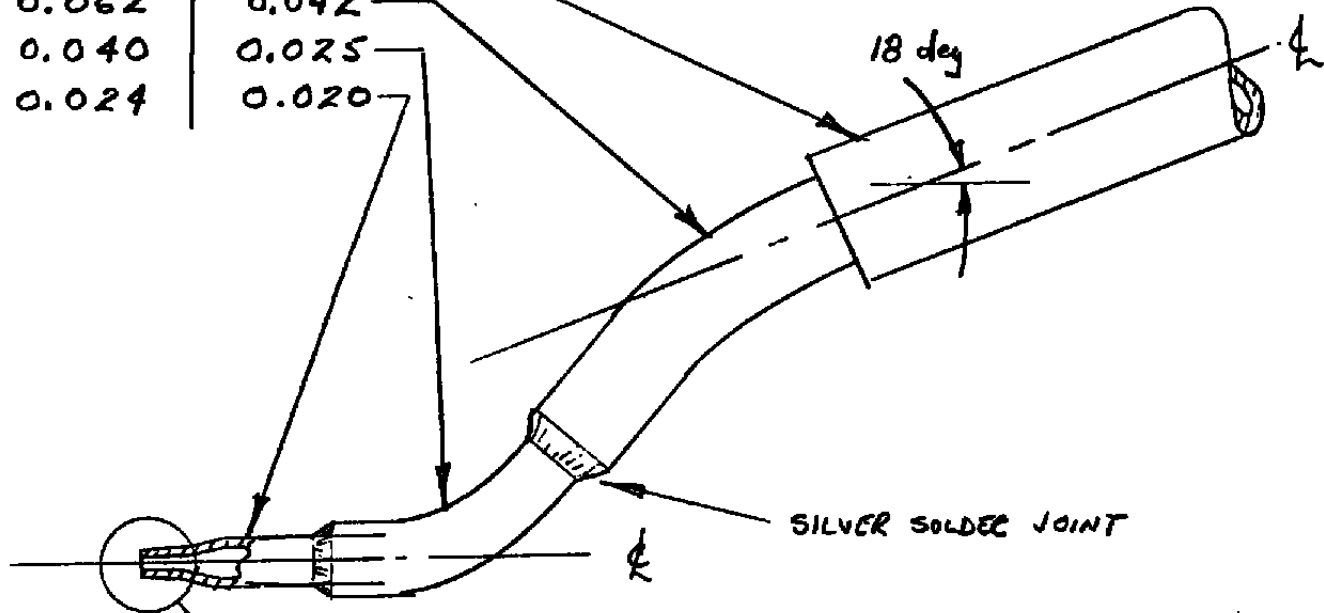

LINEAR DIMENSIONS IN INCHES.

a. Pitot probe geometry

Fig. 4 Pitot Probe Geometry and Location

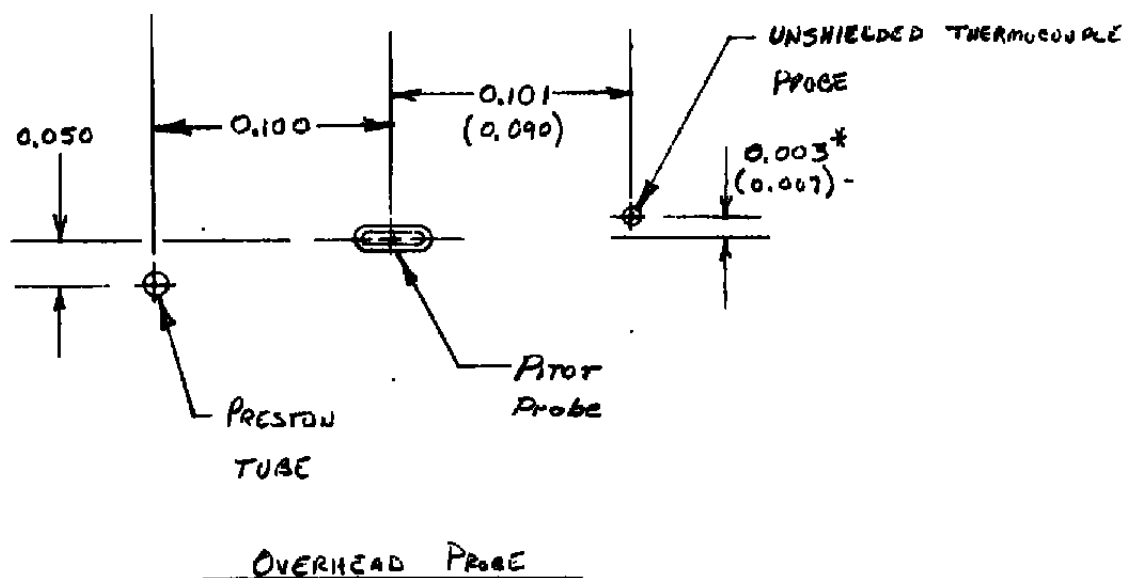

LINEAR DIMENSIONS IN INCHES

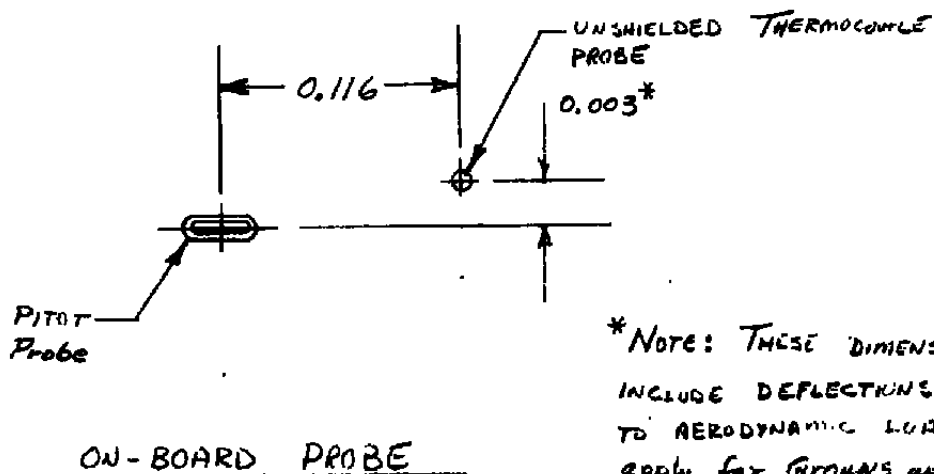

* NOTE: THESE DIMENSIONS INCLUDE DEFLECTIONS DUE TO AERODYNAMIC LOADS apply for Groups up to 188 () Applies to data group 188 and beyond.

b. Pitot probe location relative to thermocouple probe and Preston tube

Fig. 4 Concluded

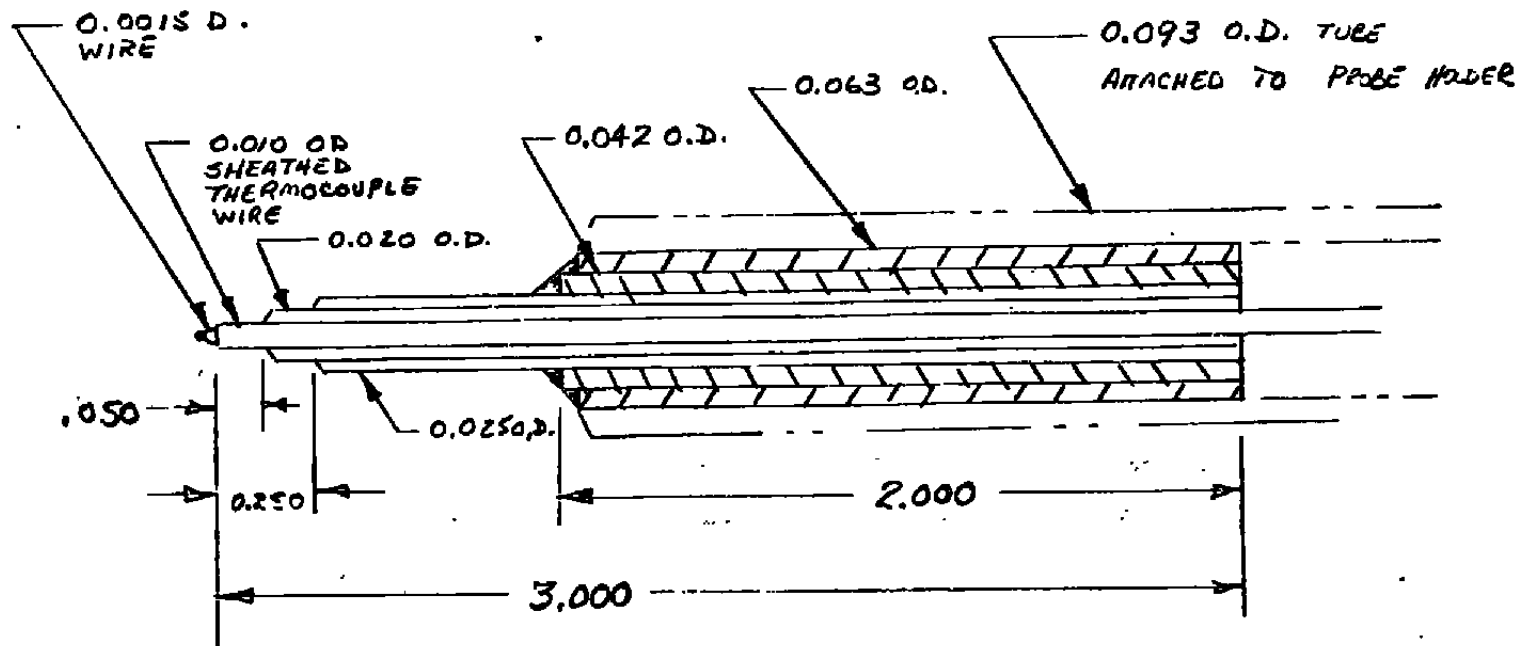

ALL DIMENSIONS IN INCHES

Fig. 5 Unshielded Total Temperature Probe

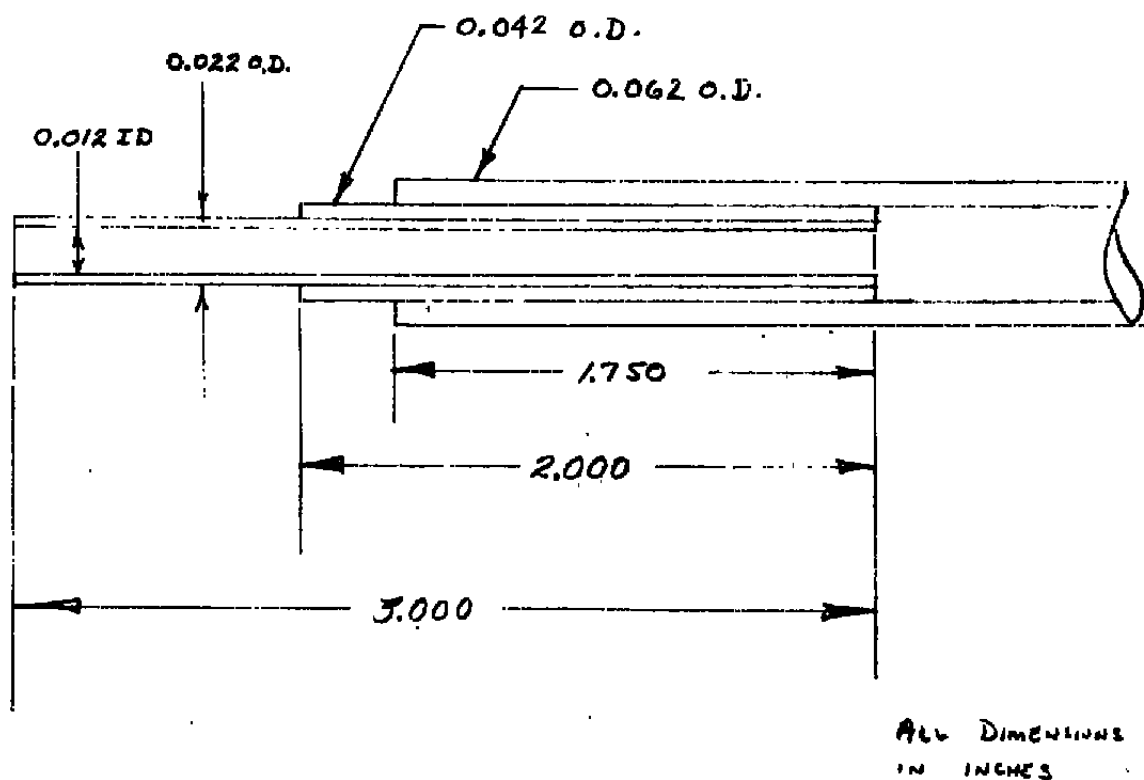

Fig. 6 Preston Tube Geometry

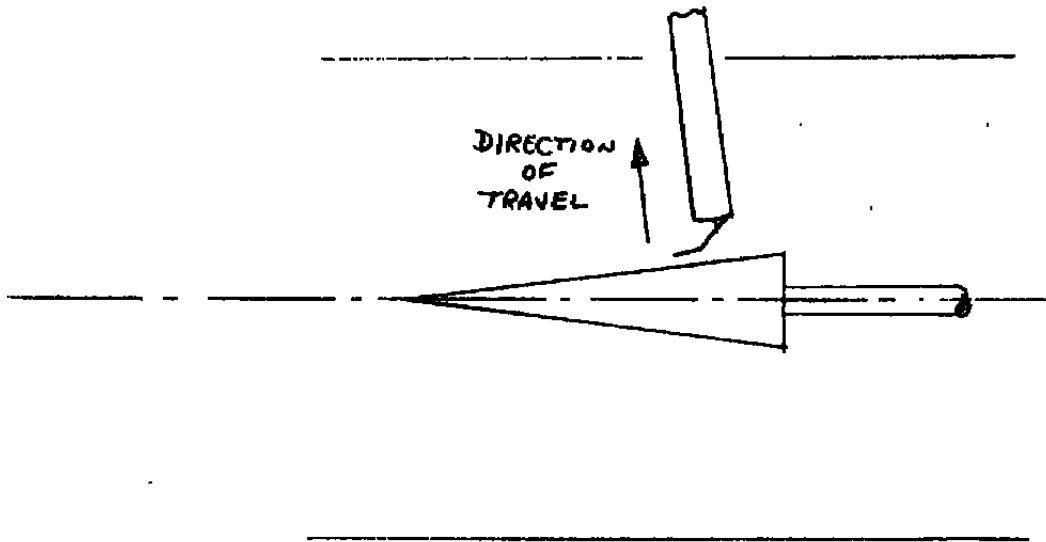

Fig. 7 Schematic of Overhead Probe Installation

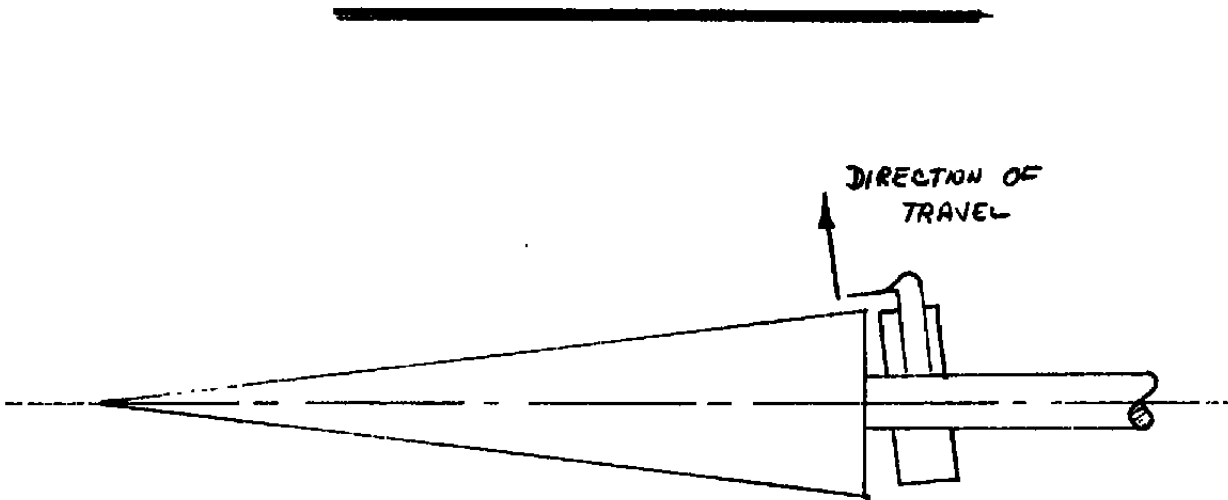
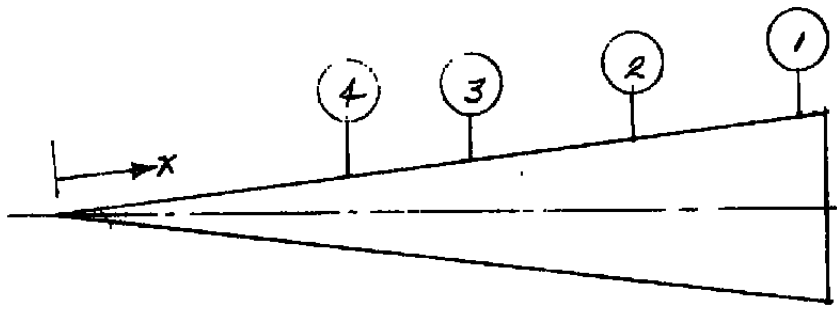
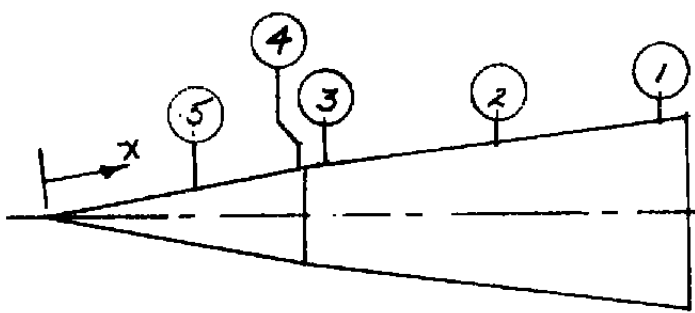

Fig. 8 Schematic of On-Board Probe Installation



7-deg CONE



10.5/7-deg BICONIC

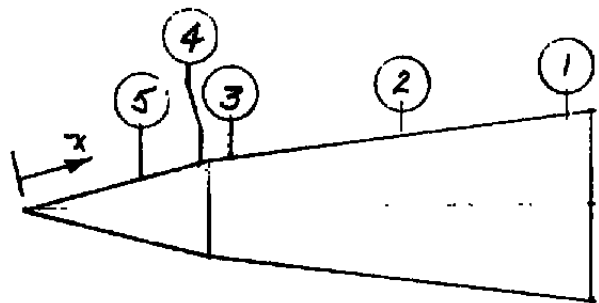

14/7-deg BICONIC

STATION NO.	X, IN.		
	7-deg CONE	10.5/7-deg BICONIC	14/7-deg BICONIC
1	38.800	32.125	28.801
2	30.300	23.625	20.301
3	20.150	14.486	11.162
4	15.150	13.233	9.909
5	—	8.483	6.159

Fig. 9 Probe Survey Locations

APPENDIX II

TABLES

TABLE 1

SURFACE INSTRUMENTATION LOCATIONS

A. PRESSURE ORIFICES

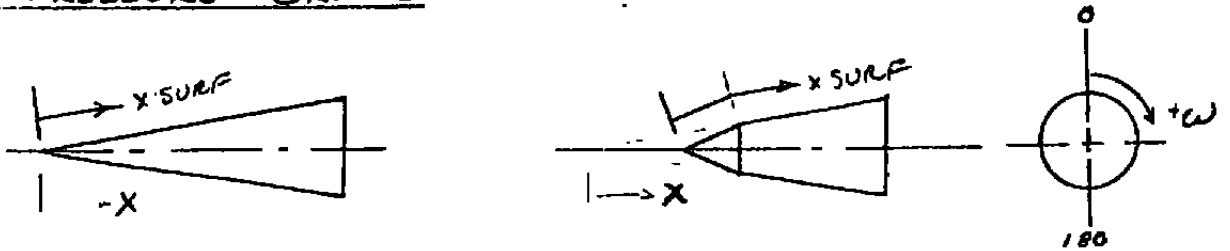

ORIFICE NO.	X SURF, IN.			ω, deg
	7-deg CONE	10.5/7 BICONIC	14/7 BICONIC	
1	39.800	33.125	29.801	0
2	38.300	31.625	28.301	
3	36.300	29.625	26.301	
4	34.300	27.625	24.301	
5	32.300	25.625	22.301	
6	30.300	23.625	20.301	
7	28.300	21.625	18.301	
8	26.300	19.625	16.301	
9	24.300	17.625	14.301	
10	22.300	15.625	12.301	
11	20.150	14.486	11.162	
12	17.150	14.111	10.787	
13	15.150	13.756	10.412	
14	13.150	13.233	9.909	
15	11.150	12.483	9.159	
16	9.150	10.983	7.159	
17	8.150	8.483	6.159	
18	-	7.483	5.159	
19	-	6.483	4.659	
20	-	5.483	4.159	
21	-	4.983	3.659	

TABLE 1 Continued

A. PRESSURE ORIFICES CONTINUED.

ORIFICE No.	X SURF, IN.			w, deg
	7- deg CONE	10.5/7 BICONIC	14/7 BICONIC	
22	39.800	33.125	29.801	-90
23	30.300	23.625	20.301	↓
24	11.150	5.483	4.659	↓
25	39.800	33.125	29.801	90
26	30.300	23.625	20.301	↓
27	11.150	5.483	4.659	↓
28	39.800	33.125	29.801	180
29	30.300	23.625	20.301	↓
30	11.150	5.483	4.659	↓
31	BASE	BASE	BASE	0
32	BASE	BASE	BASE	180
33	38.800	32.125	28.801	0

TABLE 1 Concluded

B. HEAT GAGES

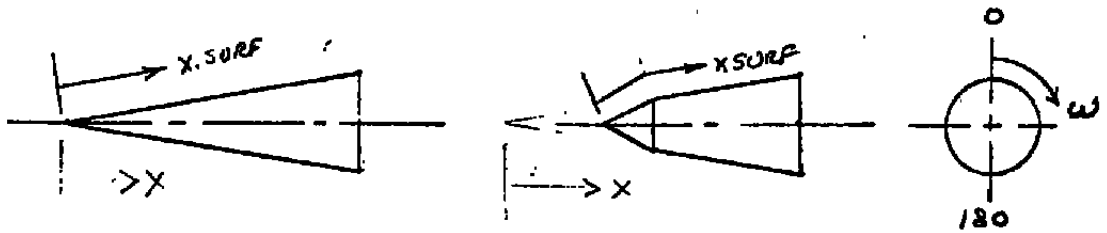

X SURF, IN.

GAGE NO.	7-deg CONE	10.5/7 BICONIC	14/7 BICONIC	ω, deg
1	38.300	31.625	28.301	180
2	36.300	29.625	26.301	
3	34.300	27.625	24.301	
4	32.240	25.565	22.241	
5	28.240	21.565	18.241	
6	26.240	19.565	16.241	
7	25.240	18.565	15.241	
8	24.240	17.565	14.241	
9	23.240	16.565	13.241	
10	22.240	15.565	12.241	
11	21.150	14.486	11.162	
12	20.150	14.111	10.787	
13	19.150	13.736	10.412	
14	18.150	13.233	9.909	
15	17.150	12.233	9.159	
16	15.150	10.483	7.159	
17	13.150	7.483	6.159	
18	9.150	6.233	5.159	
19	8.150	4.983	3.909	

TABLE 2
TEST CONDITIONS AND CONFIGURATIONS
PHASE II

*GROUP	CONFIG	NOSE RADIUS	TRIP	$R_c \times 10^6$ FT ⁻¹	α , deg	ϕ , deg	TYPE DATA	SURVEY STATION
93	7-deg	SHARP	NONE	4.7	0	0	HEAT TRANS.	-
94	↓	↓	↓	↓	↓	180	↓	-
97	↓	↓	↓	↓	↓	0	↓	-
99	↓	↓	↓	↓	↓	180	SURF. PRESS.	-
100	↓	↓	↓	↓	↓	0	"	-
102	↓	↓	↓	↓	↓		ON-BOARD PROBE	1
103	↓	↓	↓	↓	↓	180	"	1
106	↓	↓	↓	↓	↓	0	OVER-H. PROBE	1
107	↓	↓	↓	↓	↓			2
109	↓	↓	↓	↓	↓		HEAT TRANS. (NOT)	-
110	↓	↓	↓	↓	↓		HEAT TRANS.	-
112	↓	0.500	↓	↓	↓		↓	-
113	↓	↓	0.014 GRIT	↓	↓		↓	-
114	↓	↓	0.098 BALLS (BALL ALIGNED W/ GAGES)	↓	↓		↓	-
116	↓	↓	" (")	↓	↓		SURF. PRESS	-
117	↓	↓	0.093 BALLS (BALL ALIGNED W/ PILOT)	↓	↓		OVER-H. PROBE	3
118	↓	↓	" (")	↓	↓		ON-BOARD PROBE	1
119	↓	↓	0.014 GRIT	↓	↓		OVER-H. PROBE	2
120	↓	↓	↓	↓	↓		"	3
123	↓	↓	↓	↓	↓		ON-BOARD PROBE	1
124	↓	↓	↓	↓	↓		HEAT TRANS. (NOT)	-
125	↓	↓	↓	↓	↓		SURF. PRESS.	-
126	↓	↓	↓	↓	↓	180	"	-
129	10.5/7	0.050	NONE	4.7	0	0	HEAT TRANS.	-
130	BICONIC	"	↓	↓	↓	180	↓	-
131	↓	0.500	↓	↓	↓	0	↓	-
132	↓	"	0.010 GRIT	↓	↓		↓	-
134	↓	0.050	↓	↓	↓		SURF. PRESS	-
135	↓	"	↓	↓	↓	180	"	-

* MISSING GROUP NUMBERS WERE SYSTEM ZEROS, PROBE CALIBRATIONS OR SYSTEM OPERATIONAL CHECKS.

TABLE 2 Continued

* GROUP	CONFIG	NOSE RADIUS	TRIP	REYN ² , FT ⁻¹	α, deg	φ, deg	TYPE DATA	SURVEY STATION
137	10.5/7	0.500	0.010 GRIT	4.7	0	0	SURF. PRESS.	-
139	BICONIC	↓	↓	↓	↓	↓	OVER-H. PROBE	1
143	↓	↓	↓	↓	↓	↓	↓	2
146	↓	↓	↓	↓	↓	↓	↓	3
148	↓	↓	↓	↓	↓	↓	↓	4
149	↓	↓	↓	↓	↓	↓	↓	5
150	↓	↓	0.046 BALLS	(BALL ALIGNED W/PITOT)	↓	↓	↓	4
151	↓	↓	↓	(BALL <u>NOT</u> ALIGNED W/PITOT)	↓	↓	↓	4
153	↓	↓	↓	↓	↓	↓	HEAT TRANS. (BALL ALIGNED W/GAGES)	-
154	↓	↓	↓	↓	↓	↓	HEAT TRANS. (BALL <u>NOT</u> ALIGNED W/GAGES)	-
156	↓	0.050	0.010 GRIT	2.5	0	0	HEAT TRANS.	-
157	↓	↓	↓	↓	↓	180	"	-
159	↓	↓	↓	↓	↓	0	SURF. PRESS.	-
160	↓	↓	↓	↓	↓	180	"	-
161	↓	↓	↓	↓	↓	↓	OVER-H. PROBE	4
162	↓	↓	↓	↓	↓	↓	↓	1
163	↓	↓	↓	↓	↓	↓	↓	3
164	↓	0.500	0.125 BALLS	(BALL ALIGNED W/PITOT)	↓	↓	↓	3
165	↓	↓	↓	(BALL <u>NOT</u> ALIGNED W/PITOT)	↓	↓	↓	3
166	↓	↓	↓	(BALL ALIGNED W/PITOT)	↓	↓	↓	1
167	↓	↓	↓	(BALL <u>NOT</u> ALIGNED W/PITOT)	↓	↓	↓	1
168	↓	↓	0.022 GRIT	↓	↓	↓	↓	1
169	↓	↓	↓	↓	↓	↓	HEAT TRANS. (HOT)	3
171	↓	↓	↓	↓	↓	↓	"	-
172	↓	↓	↓	↓	↓	180	"	-
173	↓	↓	0.125 BALLS	(BALL ALIGNED W/GAGES)	↓	0	"	-
174	↓	↓	↓	(BALL <u>NOT</u> ALIGNED W/GAGES)	↓	0	"	-
177	14/7	0.500	NONE	2.5	0	0	HEAT TRANS.	-
178	BICONIC	↓	0.014 GRIT	↓	↓	↓	↓	-
179	↓	↓	"	↓	↓	180	↓	-
180	↓	↓	0.093 BALLS	(BALL ALIGNED W/GAGE)	↓	0	↓	-
181	↓	↓	↓	(BALL <u>NOT</u> ALIGNED W/GAGES)	↓	↓	↓	-
183	↓	↓	↓	(BALL <u>NOT</u> ALIGNED W/ORIFICES)	↓	↓	SURF. PRESS.	-
185	↓	↓	↓	(BALL ALIGNED W/ORIFICES)	↓	↓	"	-

* MISSING GROUP NUMBERS WERE SYSTEM ZEROES, PROBE CALIBRATIONS OR SYSTEM OPERATIONAL CHECKS.

TABLE 2 Concluded

*GROUP	CONFIG	NOSE RADIUS	TRIP	Re $\times 10^{-4}$, Ft $^{-1}$	α , deg	ϕ , deg	TYPE DATA	SURVEY STATION
188	14/7	0.500	0.093 BALL	2.5	0	0	OVER-H. PROBE	1
	BICONIC			(BALL ALIGNED W/PITOT)				
190								1
192				(BALL NOT ALIGNED W/PITOT)				1
193				(BALL ALIGNED W/PITOT)				2
195				(BALL NOT ALIGNED W/PITOT)				2
198			0.014 GRIT	2.5	0	0	SURF. PRESS.	-
199							OVER-H. PROBE	1
200								2
201								3
202							HEAT TRANS. (HOT)	4
203							"	-
204							"	-
205		0.050	0.000 GRIT				"	-
206			0.046 BALL				"	-
207				(BALL NOT ALIGNED W/PITOT)			OVER-H. PROBE	1
208				(" ")				3
209			0.093 BALL	(" ")				3
210				(" ")				3
211				(" ")				1
213			0.000 GRIT					1
214			"					3
215	7-deg	SHARP	NONE	4.7	0	0	OVER-H. PROBE	1
217	CONE	"	"					2
218		0.500	0.014 GRIT					1
219		0.050	0.022 GRIT	2.5				1
220		"	"					2

* MISSING GROUP NUMBERS WERE SYSTEM ZEROES, PROBE CALIBRATIONS OR SYSTEM OPERATIONAL CHECKS.

APPENDIX III

DATA REDUCTION

- 1.0 Surface Pressure Data
- 2.0 Heat Transfer Data
- 3.0 Probe Data
 - 3.1 Pitot Pressures
 - 3.2 Unshielded Thermocouple Measurements
 - 3.3 Preston Tube Data
- 4.0 Boundary-Layer Integral Values

DATA REDUCTION NOMENCLATURE

AWO	Sonic velocity based on local wall temperature (TWX), ft/sec
C1	Gardon gage calibration factor at 70°F, BTU/ft ² -sec-mv
C2	Gardon gage calibration factor at operating temperature, BTU/(ft ² -sec-mv)
DELU	Boundary-layer thickness, in.
DELU*	Boundary-layer displacement thickness, in.
DELU2	Boundary-layer momentum thickness, in.
DELU3	Boundary-layer kinetic energy thickness, in.
DELU4	Boundary-layer total enthalpy defect, in.
d	Unshielded thermocouple probe tip diameter, ft
E	Gardon gage output, mv
F10	Preston tube calibration factor
H(TO)	Heat-transfer coefficient based on T _o , BTU/ft ² -sec-°R
HU1	Shape factor, DELU*/DELU2
HU2	Shape factor, DELU2/DELU3
K	Gardon gage temperature calibration factor, °R/mv
MEO	Preston tube Mach number based on boundary-layer edge temperature (TED)
MTAUC	Friction Mach number
MUOE	Preston tube viscosity based on boundary-layer edge temperature (TED), lbf-sec/ft ²
MUI	Local Mach number at unshielded thermocouple probe location
MUPO	Viscosity based on reference temp (TEPO), lbf-sec/ft ²
MUUI	Local flow viscosity at the unshielded thermocouple probe location, lbf-sec/ft ²

MUWO	Viscosity based on wall temperature at the survey station, lbf-sec/ft ²
M _∞	Free-stream Mach number
PO, p _o	Tunnel stilling chamber pressure, psia
POUI	Local total pressure at the unshielded thermocouple probe location, psia
PPU	Local pitot pressure at unshielded thermocouple probe location, psia
PRESO	Preston tube pressure, psia
PTAUO	Dimensionless parameter
PW, PWX	Wall pressure at survey station, psia
P _∞	Free-stream static pressure, psia
q̇	Heat-flux rate, BTU/ft ² -sec
q _∞	Free-stream dynamic pressure, psia
R	Universal gas constant for air, ft ² /sec ² -°R
RB	Body radius at probe station, in.
REEO	Preston tube Reynolds number based on boundary-layer edge condition
REU	Local Reynolds number at unshielded thermocouple probe location
Re _∞ , Re _∞ /ft	Free-stream Reynolds number, ft ⁻¹
RHOED	Density based on boundary layer edge temperature (TED), slugs/ft ³
RHOOP	Density based on reference temperature (TEPO), slugs/ft ³
RHOUE	Flow-field density at the boundary-layer edge, slugs/ft ³
RHOUI	Flow-field density at the unshielded thermocouple probe location, slugs/ft ³
RHOWO	Density based on wall condition, slugs/ft ³
RTAUO	Reynolds number based on wall condition
ST(INF)	Stanton number

TCAL	Temperature parameter used to define boundary layer edge temperature (TED), °R
TED	Boundary-layer edge temperature, °R
TEDGE	Gardon gage sensing disc edge temperature, °R
TEPO	Reference temperature, °R
TEU	Boundary-layer edge total temperature deduced from corrected unshielded thermocouple probe data, °R
TO, T _o	Tunnel stilling chamber total temperature, °R
TOUI	Corrected unshielded total temperature probe measurement, °R
TOUM	Measured total temperature from the unshielded thermocouple probe, °R
TUI	Local static temperature at the unshielded thermocouple probe location, °R
TW, TWX, T _w	Model wall temperature, °R
ΔT	Temperature difference between the center and edge of a Gardon gage sensing disc, °R
UOED	Local velocity based on boundary layer edge temperature (TED), ft/sec
UUE	Boundary-layer edge velocity, ft/sec
UUI	Local velocity at unshielded thermocouple probe location, ft/sec
V _∞	Free-stream velocity, ft/sec
X, XSURF	Model station and surface length respectively, inches
ZP	Height of the pitot probe above the model surface, in.
ZU	Height of unshielded thermocouple probe above the model surface, in.
γ	Ratio of specific heats = 1.4
η, ETA	Unshielded thermocouple probe calibration function
ρ _∞	Free-stream density, slugs/ft ³

DATA REDUCTION

1.0 Surface Pressure Data

All surface pressure data were reduced using standard facility reduction procedures. Linear transducer calibration factors were obtained prior to each operational period so a simple calculation was necessary:

$$\text{PRESSURE} = \text{SCALE FACTOR}(\text{READING-ZERO}) + \text{REFERENCE}$$

2.0 Heat-Transfer Data

Thermopile-type Gardon heat gages described in Ref. 2 were used to obtain heat-transfer distribution. The heat flux to the gage is computed as follows:

$$\dot{q} = C_2 E \tag{1}$$

where C_2 = gage calibration factor, $\frac{\text{Btu}}{\text{ft}^2\text{-sec-mv}}$

E = gage output, mv

Calibration factors include compensation for variation in wall temperature:

$$C_2 = C_1 \left[4.72878 - (2.83765 \times 10^{-2})\text{TEDGE} + (7.82707 \times 10^{-5})(\text{TEDGE})^2 - (9.44869 \times 10^{-8})(\text{TEDGE})^3 + (4.30151 \times 10^{-11})(\text{TEDGE})^4 \right] \tag{2}$$

C_1 = gage calibration factor at 530°R

TEDGE = gage sensing disc edge temperature, °R

where C_1 is the gage calibration factor at 530°R

The temperature difference between the center and the edge of the sensing disc was calculated by:

$$\Delta T = K \cdot E \tag{3}$$

where:

K = gage temperature calibration factor, °R/mv

The gage edge temperature was measured directly and combined with ΔT to obtain an effective wall temperature:

$$T_w = T_{EDGE} + 0.75 \Delta T \quad (4)$$

This method of obtaining an effective wall temperature is discussed in detail in Ref. 2.

Heat-transfer coefficient was then calculated as:

$$H(TO) = \frac{\dot{q}}{TO - TW} \quad (5)$$

Further reduction to Stanton number was achieved using the following:

$$ST(INF) = \frac{H(TO)}{\rho_\infty V_\infty \left[0.2235 + (1.35 \times 10^{-5})(TO + TW) \right]} \quad (6)$$

3.0 Probe Data

Mean-flow boundary-layer data are presented as measured pressure and temperature values. Final reduced boundary-layer parameters are calculated only for those cases which satisfy the requirements for defining a boundary-layer edge. True probe heights above the cone surface were determined in the radial direction. The curvature of the model surface at the survey station, the lateral spacing of the probes in the rake, and the relative vertical spacing of the measurement probes were taken into account.

3.1 Pitot Pressures

Pitot pressure data were reduced following the procedures described in Section 1.0 which apply to surface pressure.

3.2 Unshielded Thermocouple Measurements

This section contains the procedure for obtaining local total temperature from the unshielded thermocouple probe output. The nomenclature used applies to the on-board probe although the identical procedure was for the overhead probe. The procedure, shown in a block diagram (page 37) is as follows:

- U-1. Interpolate the local pitot pressure, PPO, from ZP to a value at the ZU locations. Designate the interpolated pitot values as PPU.

U-2. Compute the local Mach number, MUI, as follows:

a. If $PPU/PWX \leq \left[(\gamma+1)/2 \right]^{\frac{\gamma}{\gamma-1}}$

b. Then $MUI = \left\{ \left[(PPU/PWX)^{\frac{\gamma-1}{\gamma}} - 1 \right] \left[2/(\gamma-1) \right] \right\}^{1/2}$

Otherwise, iterate the following to obtain MUI:

c. $PPU/PWX = \left[(\gamma+1)(MUI)^2/2 \right]^{\frac{\gamma}{\gamma-1}} \left[(\gamma+1)/(2\gamma(MUI)^2 - (\gamma-1)) \right]^{\frac{1}{\gamma-1}}$

where PWX is the wall pressure at the survey station

U-3. If $MUI \leq 1$, $POUI = PPU$

If $MUI > 1$

$$POUI = PPU \left[\frac{(\gamma-1)(MUI)^2 + 2}{(\gamma+1)(MUI)^2} \right]^{\frac{\gamma}{\gamma-1}} \left[\frac{2\gamma(MUI)^2 - (\gamma-1)}{\gamma+1} \right]^{\frac{1}{\gamma-1}}$$

U-4. $RHOUI = \left(\frac{144}{R} \frac{PWX}{TOUI} \right) \left[1 + \frac{\gamma-1}{2} (MUI)^2 \right]$

U-5. $TUI = TOUI \left(1 + \frac{(MUI)^2}{5} \right)^{-1}$

U-6. $UUI = MUI \left(\gamma R(TUI) \right)^{1/2}$

U-7. $MUUI = \frac{0.227(10^{-7})(TOUI)^{3/2}}{199 + TOUI}$

U-8. $REU = \frac{(RHOUI)(UUI)(d)}{MUUI}$

$$U-9. \quad \eta = \text{ETA} = \sum_{N=0}^4 AN(\text{REU})^{N/2}$$

where AN are calibration constants unique to each probe

$$U-10. \quad \text{TOUI} = \text{TOUM} \left[\frac{1 + \frac{\gamma-1}{2} (\text{MUI})^2}{1 + \frac{\gamma-1}{2} \eta (\text{MUI})^2} \right]$$

Input Data:

TOUM VS ZU
POUI VS ZU
MUI VS ZU

At each ZU value, the data was corrected as follows:

- (a) Assume TOUI = TOUM, compute REU from Eq. U-8.
- (b) Compute η from Eq. U-9.
- (c) Compute corrected temperature, TOUI, from Eq. U-10.
- (d) Using the corrected value of TOUI, repeat steps (a) thru (c) until

$$\frac{\left(\frac{\text{TOUM}}{\text{TOUI}} \right)_{j+1} - \left(\frac{\text{TOUM}}{\text{TOUI}} \right)_j}{\left(\frac{\text{TOUM}}{\text{TOUI}} \right)_j} \leq 0.0005$$

Input constants:

d - Probe tip diameter = 0.005 in. = 0.0004167 ft.

$\gamma = 1.4$, ratio of specific heats.

3.3 Preston Tube Data

Calculation procedures outlined in this section were used to evaluate shear stress at the model wall as described in Refs. 4 and 5. The initial survey point with the Preston tube in contact with the model surface was the only valid data point. The calculation procedures shown in the block diagram (page 39) are as follows:

ON-BOARD UNSHIELDED THERMOCOUPLE CALCULATION
BLOCK DIAGRAM

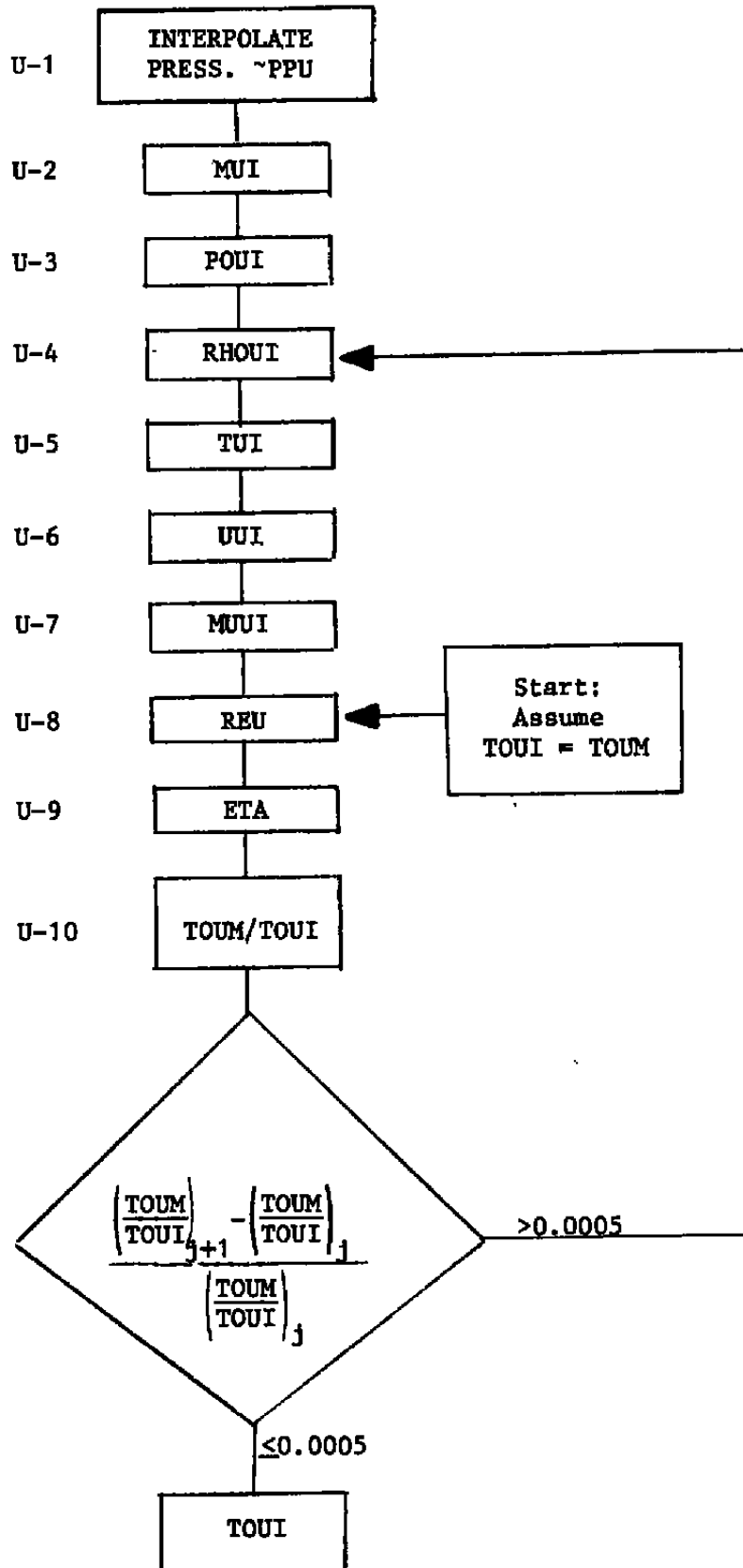

$$PO-1. \quad TAUWO = \left[\frac{PRESO - PWX}{PTAUO} \right] 144, \text{ psf}$$

$$PO-2. \quad AWO = \left[\gamma R(TWX) \right]^{1/2}$$

$$PO-3. \quad RHOWO = \frac{(PWX)(144)}{R(TWX)}$$

$$PO-4. \quad MTAUO = (TAUWO)^{1/2} / (AWO) (RHOWO)^{1/2}$$

$$PO-5. \quad MUWO = \frac{0.227(10^{-7})(TWX)^{3/2}}{199 + TWX}$$

$$PO-6. \quad RTAUO = \left[\frac{DPO}{MUWO} \right] \left[(TAUWO) (RHOWO) \right]^{1/2}$$

where DPO = PRESTON TUBE O.D., 0.001667 FT.

$$PO-7. \quad \begin{aligned} PTAUOO &= 96 + 60 \log_{10} (RTAUO/50) \\ &+ 23.7 \left[\log_{10} (RTAUO/50) \right]^2 \\ &+ (10^4) (MTAUO)^2 \left[(RTAUO)^{0.3} - 2.38 \right] \end{aligned}$$

$$PO-8. \quad PTAUO_{1+1} = \frac{PTAUOO + PTAUO1}{2}$$

The following equations as formulated by Allen in Ref. 5 are used to assess Preston tube calibration precision band on data.

$$1. \quad MUOE = \frac{0.227(10^{-7})(TED)^{3/2}}{199 + TED}$$

$$2. \quad REEO = \frac{(RHOED)(UOED)(DPO)}{MUOE}$$

3. Compute local Mach number, MOO, as follows:

$$a. \quad \text{If } PRESO/PWX \leq \left[\left((\gamma+1)/2 \right)^{\frac{\gamma}{\gamma-1}} \right]$$

$$b. \quad \text{Then } MOO = \left\{ \left[(PRESO/PWX)^{\frac{\gamma-1}{\gamma}} - 1 \right] \left[2/(\gamma-1) \right] \right\}^{\frac{1}{\gamma-1}}$$

Otherwise, iterate the following to obtain MOO:

$$PRESO/PWX = \left[(\gamma+1)(MOO)^2/2 \right]^{\frac{\gamma}{\gamma-1}} \left[(\gamma+1)/(2\gamma(MOO)^2 - (\gamma-1)) \right]^{\frac{1}{\gamma-1}}$$

PRESTON TUBE CALCULATION BLOCK DIAGRAM

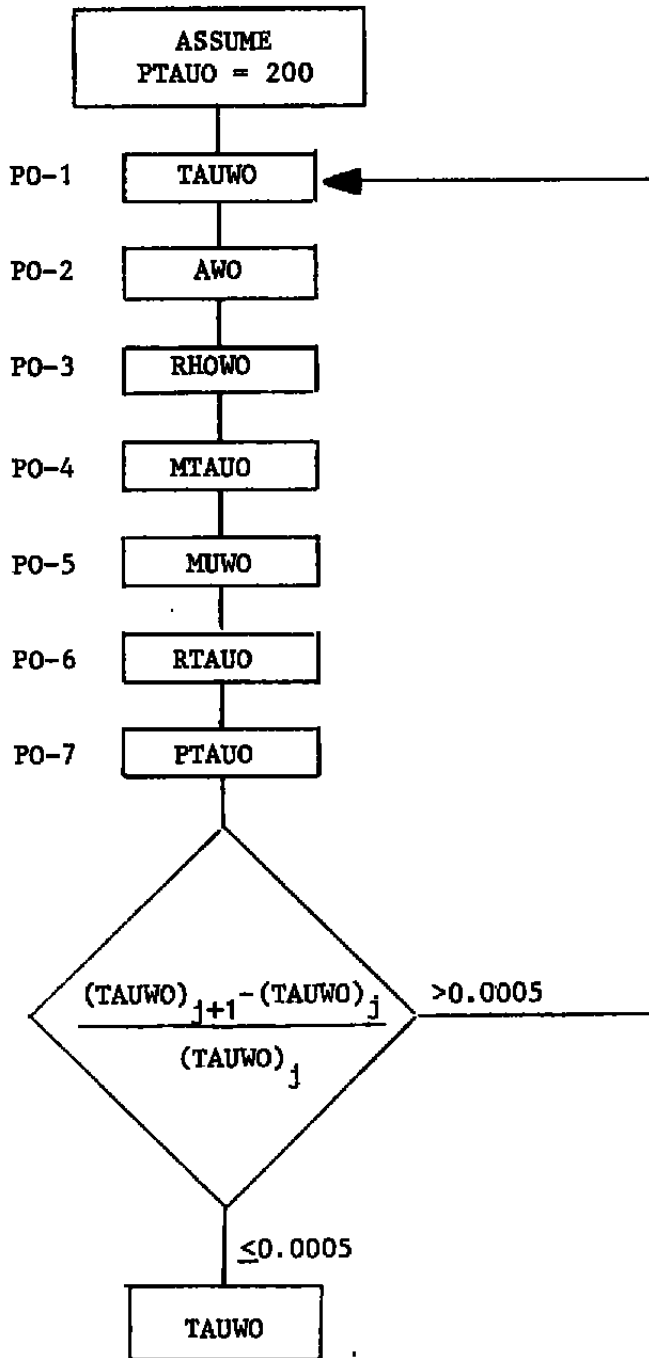

4. $UPTO = (MOO) \left[\gamma_{RTWX} \right]^{1/2}$
5. $MEO = (UOED) \left[\gamma_R(TED) \right]^{-1/2}$
6. $RHOOP/RHOED = \left[1 + 0.035 (MEO)^2 + 0.45 \left(\frac{TWX}{TED} - 1 \right) \right]^{-1}$
7. $TED/TEPO = \left[1 + 0.035 (MEO)^2 + 0.45 \left(\frac{TWX}{TED} - 1 \right) \right]^{-1}$
8. $TEPO = \left(\frac{TED}{TEPO} \right)^{-1} (TED)$
9. $MUOE/MUPO = \left[\left(\frac{TED}{TEPO} \right)^{1.5} \left(\frac{TEPO + 199}{TED + 199} \right) \right]$
10. $F10 = \left(\frac{RHOOP}{RHOED} \right) \left(\frac{MUOE}{MUPO} \right) (REEO) \left(\frac{UPTO}{UOED} \right)$

4.0 Boundary-Layer Integral Values

The procedures described in this section were used to evaluate boundary-layer parameters from integral relationships. Establishment of the boundary-layer edge location and flow conditions is required to establish the upper limit for the integrals. Note the precautions listed with the calculations.

1. Input data:

TOUI vs ZU

where TOUI is the corrected unshielded thermocouple value.

2. At the value of ZU nearest 0.700 in. set TCAL = TOUI.
3. Moving from the point ZU = 0.7 towards ZU = 0, curve fit the data set TOUI vs ZU. Sets of five points should be fitted with a second order (parabolic) fit.
4. Evaluate the curve fit segments and locate the value of ZU at which the value of TOUI = TCAL (1 ± 0.0025).

NOTE: For cases where TOUI = 0.9975 TCAL,
print message:

"BOUNDARY LAYER EDGE CONDITIONS OF TOTAL
TEMPERATURE OVERSHOOT NOT MET. INTEGRAL
PARAMETERS SHOULD BE USED WITH CAUTION."

5. When the point in Item 4 has been located evaluate both TOUI and ZU and designate as follows:

DELU = ZU

TEU = TOUI

6. Input data:

RHOUI vs ZU (boundary-layer edge)

UII vs ZU

7. Using the same ZU values used in Item 4, fit the data from Item 6 with a second order (parabolic) fit.
8. Evaluate the curve fits in Item 7 at DELU = ZU. Designate the values of RHOUI and UII as follows:

$$\left. \begin{array}{l} \text{RHOUI} = \text{RHOUE} \\ \text{UII} = \text{UIE} \end{array} \right\} @ \text{ DELU}$$

9. Determine displacement thickness by evaluating the following:

$$\text{DELU}^* + (\text{DELU}^*)^2 \frac{\cos \theta}{2(\text{RB})} = \int_{\text{ZU}=0}^{\text{DELU}} \left[1 - \frac{(\text{RHOUI})(\text{UII})}{(\text{RHOUE})(\text{UIE})} \right] \left[1 + \frac{(\text{ZU})(\cos \theta)}{\text{RB}} \right] d\text{ZU}$$

where θ = body surface angle at the survey station, deg

RB = body radius at the survey station, in.
(normal to model axis)

Use the quadratic equation:

$$\text{DELU}^* = \frac{\sqrt{b^2 - 4ac} - b}{2a}$$

where

$$a = \frac{\cos \theta}{2(\text{RB})}$$

$$b = 1$$

$$c = - \int_{\text{ZU}=0}^{\text{DELU}} \left[1 - \frac{(\text{RHOUI})(\text{UII})}{(\text{RHOUE})(\text{UIE})} \right] \left[1 + \frac{(\text{ZU})(\cos \theta)}{\text{RB}} \right] d\text{ZU}$$

10. Determine momentum thickness by evaluating the following:

$$\text{DELU}2 + (\text{DELU}2)^2 \frac{\cos \theta}{2\text{RB}} = \int_{\text{ZU}=0}^{\text{DELU}} \frac{(\text{RHOUI})(\text{UII})}{(\text{RHOUE})(\text{UIE})} \left[1 - \frac{\text{UII}}{\text{UIE}} \right] \left[1 + \frac{(\text{ZU})(\cos \theta)}{\text{RB}} \right] d\text{ZU}$$

Use the quadratic equation:

$$\text{DELU}2 = \frac{\sqrt{b^2 - 4ac} - b}{2a}$$

where

$$a = \frac{\cos \theta}{2RB}$$

$$b = 1$$

$$c = - \int_{ZU=0}^{DELU} \frac{(\text{RHOUI})(\text{UUI})}{(\text{RHOUE})(\text{UUE})} \left[1 - \frac{\text{UUI}}{\text{UUE}} \right] \left(1 + \frac{(\text{ZU})(\cos \theta)}{RB} \right) dZU$$

11. Determine the kinetic energy defect from the following:

$$DELU3 + (\text{DELU3})^2 \frac{\cos \theta}{2RB} = \int_{ZU=0}^{DELU} \frac{(\text{RHOUI})(\text{UUI})}{(\text{RHOUE})(\text{UUE})} \left[1 - \left(\frac{\text{UUI}}{\text{UUE}} \right)^2 \right] \left(1 + \frac{(\text{ZU})(\cos \theta)}{RB} \right) dZU$$

Use the quadratic equation:

$$\text{DELU3} = \frac{\sqrt{b^2 - 4ac} - b}{2a}$$

where

$$a = \frac{\cos \theta}{2RB}$$

$$b = 1$$

$$c = - \int_{ZU=0}^{DELU} \frac{(\text{RHOUI})(\text{UUI})}{(\text{RHOUE})(\text{UUE})} \left[1 - \left(\frac{\text{UUI}}{\text{UUE}} \right)^2 \right] \left(1 + \frac{(\text{ZU})(\cos \theta)}{RB} \right) dZU$$

12. Determine the total enthalpy defect:

$$\text{DELU4} + (\text{DELU4})^2 \frac{\cos \theta}{2RB} = \int_{ZU=0}^{DELU} \frac{(\text{RHOUI})(\text{UUI})}{(\text{RHOUE})(\text{UUE})} \left[1 - \frac{\text{TOUI}}{\text{TEU}} \right] \left(1 + \frac{(\text{ZU})(\cos \theta)}{RB} \right) dZU$$

Use the quadratic equation:

$$\text{DELU4} = \frac{\sqrt{b^2 - 4ac} - b}{2a}$$

where

$$a = \frac{\cos \theta}{2RB}$$

$$b = 1$$

$$c = - \int_{ZU=0}^{DELU} \frac{(\text{RHOUI})(\text{UUI})}{(\text{RHOUE})(\text{UUE})} \left[1 - \frac{\text{TOUI}}{\text{TEU}} \right] \left(1 + \frac{(\text{ZU})(\cos \theta)}{RB} \right) dZU$$

13. Calculate shape factor:

$$HU1 = \frac{DELU*}{DELU2}$$

$$HU2 = \frac{DELU2}{DELU3}$$

APPENDIX IV

SAMPLE DATA NOMENCLATURE AND FORMATS

1. Nomenclature: Surface Pressure Data
2. Sample Data: Surface Pressure Data
3. Nomenclature: Heat-Transfer Data
4. Sample Data: Heat-Transfer Data
5. Nomenclature: On-Board Probe Flow-Field Data
6. Sample Data: On-Board Probe Flow-Field Data
7. Nomenclature: Overhead Probe Flow-Field Data
8. Sample Data: Overhead Probe Flow-Field Data

IV-1. NOMENCLATURE: SURFACE PRESSURE DATA

ALPHA MODEL	Model angle of attack, deg
ALPHA PB	Support sting prebend angle, deg
CONFIGURATION	Model configuration (see Fig. 2)
DATA TYPE	Type of data tabulated
DEW POINT	Free-stream flow frost point, °F
GROUP	Data group number
L	Sharp 7-deg cone axial length, 40 in.
M(INF)	Free-stream Mach number
MU(INF)	Free-stream viscosity, lbf-sec/ft ²
NOSE RADIUS	Model nose tip radius, in.
ORIFICE	Model pressure orifice identification (see Table 1)
PHI	Pressure orifice circumferential location (see Table 1), deg
P(INF)	Free-stream static pressure, psia
PO	Tunnel stilling chamber pressure, psia
POP	Free-stream normal shock pressure, psia
PW	Model wall pressure, psia
Q(INF)	Free-stream dynamic pressure, psia
RE(INF)	Free-stream Reynolds number, per foot
RHO(INF)	Free-stream density, slugs/ft ³
ROLL	Model roll angle, deg
T(INF)	Free-stream static temperature, °R
TO	Tunnel stilling chamber temperature, °R
TRIP	Boundary-layer trip configuration (sphere diam or nominal trip height in inches)
U(INF)	Free-stream velocity, ft/sec
X	Orifice model station, in.
XSURF	Orifice surface location, in.

PROJECT NO Y41B-W6A
 SAMSO/DOTR HYPERSONIC TURBULENT BOUNDARY LAYER INVESTIGATION
 PHASE II

GROUP 99 ALPHA MODEL = 0.02 DEG. DEW PT=-32.00 CONFIGURATION NOSE RADIUS, IN TRIP
 N(INF)= 5.95 ALPHA PB = 0.00 DEG. (DEG F) 7-DEG CONE SHARP NONE
 RE(INF)= 4.588E+06 PER FT ROLL = -179.94 DEG.

DATA TYPE
 SURFACE PRES

ORIFICE	X (IN)	X/L	XSURF (IN)	PHI (DEG)	P4 (PSIA)	P4/PINF
17	8.090	0.7023	8.150	0.	0.347	2.08
16	9.082	0.2271	9.150	0.	0.343	2.06
15	11.067	0.2767	11.150	0.	0.336	2.01
14	13.052	0.3263	13.150	0.	0.325	1.95
13	15.037	0.3759	15.225	0.	0.335	2.00
12	17.023	0.4256	17.150	0.	0.341	2.04
11	20.000	0.5000	20.025	0.	0.325	1.95
10	22.075	0.5519	22.300	0.	0.327	1.96
9	24.060	0.6015	24.300	0.	0.329	1.97
8	26.045	0.6511	26.300	0.	0.325	1.95
7	28.030	0.7008	28.300	0.	0.429	2.57
6	30.015	0.7504	30.125	0.	0.329	1.97
5	32.000	0.8000	32.300	0.	0.324	1.94
4	33.985	0.8496	34.300	0.	0.329	1.97
3	35.970	0.8993	36.300	0.	0.329	1.97
2	38.015	0.9504	38.300	0.	0.337	2.02
1	39.504	0.9876	39.800	0.	0.331	1.98
24	11.067	0.2767	11.150	-90.	0.332	1.99
23	30.015	0.7504	30.300	-90.	0.328	1.96
22	39.504	0.9876	39.800	-90.	0.330	1.98
27	11.067	0.2767	11.150	90.	0.322	1.93
26	30.015	0.7504	30.300	90.	0.319	1.91
25	39.504	0.9876	39.800	90.	0.329	1.97
30	11.067	0.2767	11.150	180.	0.328	1.97
29	30.015	0.7504	30.300	180.	0.316	1.89
28	39.504	0.9876	39.800	180.	0.330	1.98
33	38.511	0.9628	39.650	0.	0.331	1.98
31		BASE	BASE	0.	0.148	0.89
32		BASE	BASE	180.	0.073	0.44

IV-2. Sample Data: Surface Pressure Data

PO = 250.51 PSIA U(INF)= 3017.3 FT/SEC
 TO = 864.7 DEGR Q(INF)= 4.139 PSIA
 P(INF)= 0.1670 PSIA T(INF)= 107.0 DEGR
 RE(INF)= 0.459E+07 PER FT POP = 7.69 PSIA
 MU(INF)= 0.861E-07 LBF-SEC/FT2 RHO(INF)= 0.111E-03 SLUGS/FT3

IV-3. NOMENCLATURE: HEAT-TRANSFER DATA

ALPHA MODEL	Model angle of attack, deg
ALPHA PREBND	Support sting prebend angle, deg
ALPHA SECTOR	Tunnel sector pitch angle, deg
CONFIGURATION	Model configuration (see Fig. 2)
DATA TYPE	Type of data tabulated
DEW PT	Free-stream flow frost point, °F
GAGE NO.	Gardon gage identification number (see Table 1)
GROUP	Data group number
H(TO)	Heat-transfer coefficient, $\text{BTU/FT}^2\text{-sec-}^\circ\text{R}$
L	Sharp 7-deg cone axial length, 40 in.
M(INF)	Free-stream Mach number
MODE	Static or dynamic data mode identification
MU(INF)	Free-stream viscosity, lbf-sec/ft^2
NOSE RADIUS	Model nose tip radius, in.
P(INF)	Free-stream static pressure, psia
PO	Tunnel stilling chamber pressure, psia
QDOT	Heat-flux rate, $\text{BTU/FT}^2\text{-sec}$
Q(INF)	Free-stream dynamic pressure, psia
RE(INF)	Free-stream Reynolds number, per ft
RHO(INF)	Free-stream density, lbm/ft^3
ROLL	Model roll angle, deg
ST(INF)	Stanton number
ST(INF) (CORRECTED)	Stanton number corrected (see Section 4.5)
TEDGE	Gardon gage sensing disc edge temperature, °R
T(INF)	Free-stream static temperature, °R
TO	Tunnel stilling chamber temperature, °R

TRIP	Boundary-layer trip configuration (sphere diam or nominal trip height in inches)
TW	Model wall temperature, °R
V(INF)	Free-stream velocity, ft/sec
X	Model station, in.
X _{SURF}	Surface length, in.

ARO, INC.
 AEDC DIVISION
 A SVEPNRUP CORPORATION COMPANY
 VON KARMAN GAS DYNAMICS FACILITY
 50 INCH HYPERSONIC TUNNEL B
 ARNOLD AIR FORCE STATION, TN.
 DATE 04/18/78 PROJECT NO. Y41B-W6A

BANSO/DOIR HYPERSONIC TURBULENT BOUNDARY LAYER INVESTIGATION
 PHASE II
 GARDON GAGES

DATE 04/13/78 TIME 22:34:24:180 TIME REDUCED 22:34:47:1616 TIME FROM CL 1.04

DATA TYPE HEAT TRANSFER CONFIGURATION 7-DEG CONE NOSE RADIUS, IN. SHARP TRIP NONE MODE STATIC

GAGE NO.	X (IN.)	X/L	X SURFACE	ODOT (BTU/FT2-SEC)	TEDGE (DEG.R)	TW (DEG.R)	H(TO) (BTU/FT2-SEC-DEGR)	ST(INF)	ST(INF) (CORRECTED)
G19	8.090	.2023	8.150	0.2752	533.1	534.5	0.884E-03	0.285E-03	0.267E-03
G18	9.082	.2271	9.150	0.2747	533.3	534.8	0.884E-03	0.284E-03	0.273E-03
G17	13.052	.3263	13.150	0.7333	535.0	538.9	0.239E-02	0.769E-03	0.745E-03
G16	15.037	.3759	15.150	OMIT					
G15	17.023	.4256	17.150	OMIT					
G14	18.015	.4504	18.150	0.7886	535.1	539.2	0.257E-02	0.828E-03	0.895E-03
G13	19.008	.4752	19.150	0.7308	534.4	538.2	0.238E-02	0.765E-03	0.802E-03
G12	20.000	.5000	20.150	0.7085	535.9	539.6	0.232E-02	0.745E-03	0.870E-03
G11	20.993	.5248	21.150	0.7544	536.2	540.1	0.247E-02	0.795E-03	0.828E-03
G10	27.075	.5519	27.240	OMIT		537.6			
G9	23.067	.5767	23.240	OMIT					
G8	24.060	.6015	24.240	0.8333	536.4	540.7	0.273E-02	0.880E-03	0.819E-03
G7	25.052	.6263	25.240	0.7495	535.0	538.9	0.244E-02	0.786E-03	0.768E-03
G6	26.045	.6511	26.240	OMIT					
G5	28.030	.7008	28.240	0.7206	535.4	539.1	0.235E-02	0.757E-03	0.766E-03
G4	32.000	.8000	32.240	0.7427	535.4	539.2	0.242E-02	0.780E-03	0.695E-03
G3	33.985	.8496	34.300	0.7614	535.4	539.3	0.249E-02	0.800E-03	0.786E-03
G2	35.970	.8993	36.300	0.7311	535.0	538.9	0.238E-02	0.767E-03	0.799E-03
G1	38.015	.9504	38.300			536.4			

Sample Data: Heat-Transfer Data

H(INF) = 5.95
 POL(L) = -0.04 DEG.
 ALPHA SECTOR = 0.01 DEG.
 ALPHA PREBND = 0.00 DEG.
 ALPHA MODEL = 0.01 DEG.

PO = 250.01 PSIA
 TO = 845.7 DEG.R
 P(INF) = .1667 PSIA
 RE(INF) = 4.734E+06 PER FT.
 MU(INF) = 8.422E-08 LBF-SEC/FT2
 RHO(INF) = 4.299E-03 LBM/FT3

V(INF) = 2984.0 FT/SEC
 Q(INF) = 4.131 PSIA
 T(INF) = 104.7 DEG.R
 DEW PT = -32. DEG.F

IV-5. NOMENCLATURE: ON-BOARD PROBE FLOW-FIELD

PRINTOUT PAGE ONE

ALPHA MODEL	Model angle of attack, deg
ALPHA PB	Support Sting prebend angle, deg
CONFIGURATION	Model configuration (see Fig. 2)
DATA TYPE	Type of data tabulated
DEW PT	Free-stream flow frost point, °F
GROUP	Data group number
LOOP	Data point identification number
M(INF)	Free-stream Mach number
MU(INF)	Free-stream viscosity, lbf-sec/ft ²
NOSE RADIUS	Model nose tip radius, in.
P(INF), PINF	Free-stream static pressure, psia
PO	Tunnel stilling chamber pressure, psia
POP	Free-stream total pressure downstream of a normal shock, psia
PPO	On-board probe pitot pressure, psia
PROBE STATION	Probe station location measured along model surface from model nose tip, in.
PWX	Model wall pressure at the survey station (x), psia
Q(INF)	Free-stream dynamic pressure, psia
RE(INF)	Free-stream Reynolds number, per foot
RHO(INF)	Free-stream density, slugs/ft ³
ROLL	Model roll angle, deg
T(INF)	Free-stream static temperature, °R
TGX	Surface temperature at model station (X), °R
TO	Tunnel stilling chamber temperature, °R
TOUI	Corrected total temperature probe measurement, °R
TOUM	Unshielded thermocouple probe total temperature measurement, °R

TRIP	Boundary-layer trip configuration - sphere and grit dimensions stated in inches
TWX	Model wall temperature at probe survey station, °R
UUI	Local velocity, ft/sec
U(INF)	Free-stream velocity, ft/sec
ZP	Height of the pitot probe above the model surface, in.
ZU	Height of unshielded thermocouple probe above model surface, in.

PRINTOUT PAGE TWO

All heading information is identical to page one.

TG-1 to TG-19	Gardon gage case temperature, °R
---------------	----------------------------------

PRINTOUT PAGE THREE (Unshielded Temperature Probe Correction)

All heading information is identical to page one.

A0 to A4	Calibration constants
ETA	Effective probe recovery factor
LOOP	Data point identification number
MUI	Local Mach number at survey point
PO	Tunnel stilling chamber pressure, psia
PPU	Local pitot pressure interpolated for total temperature probe height ZU
REU	Local Reynolds number at survey point

All the following parameters defined in Appendix III.

DELU, DELUX, DELU2, DELU3, DELU4, HU1, HU2, TEU, UUE and RHOUE.

PROJECT NO V41B-W6A
 SAMSO/DOTR HYPERSONIC TURBULENT BOUNDARY LAYER INVESTIGATION
 PHASE II

GROUP 102 ALPHA MODEL = 0.05 DEG. DEM PT=-32.00 CONFIGURATION NOSE RADIUS, IN TRIP
 K(INF)= 5.95 ALPHA PB = 0.00 DEG. (DEG F) 7-DEG CONE SHARP NONE
 RE(INF)= 4.764E+06 PER FT ROLL = 0.04 DEG.

DATA TYPE
 ON-BOARD PROBE

PROBE STATION = 38.650 IN. STATION NO. = 1

LOOP	PO (PSIA)	TO (DEGR)	PINF (PSIA)	POP (PSIA)	ZP (IN)	PPO (PSIA)	PPD/POP	PW33 (PSIA)	TG1 (DEGR)	ZU (IN)	TCUM (DEGR)	TCUM/TO
1	250.91	841.7	0.167	7.703	0.0060	0.628	0.0815	0.328	734.	0.0104	760.	0.899
2	250.91	842.7	0.167	7.700	0.0085	0.629	0.0817	0.329	734.	0.0129	761.	0.901
3	251.11	841.7	0.167	7.710	0.0140	0.787	0.1021	0.329	734.	0.0164	762.	0.902
4	251.01	844.7	0.167	7.706	0.0185	1.136	0.1473	0.329	735.	0.0229	763.	0.903
5	251.21	844.7	0.167	7.713	0.0215	1.571	0.2037	0.329	735.	0.0259	764.	0.904
6	251.31	845.7	0.168	7.716	0.0275	1.849	0.2396	0.329	735.	0.0319	764.	0.904
7	251.62	844.7	0.168	7.725	0.0365	2.251	0.2915	0.329	735.	0.0409	766.	0.906
8	251.62	845.7	0.168	7.725	0.0465	2.510	0.3249	0.330	735.	0.0509	767.	0.908
9	251.92	845.7	0.168	7.734	0.0555	2.732	0.3533	0.330	736.	0.0599	769.	0.910
10	251.82	842.7	0.168	7.731	0.0670	2.978	0.3953	0.330	736.	0.0714	772.	0.914
11	251.92	842.7	0.168	7.734	0.0765	3.181	0.4113	0.330	736.	0.0809	774.	0.916
12	252.22	845.7	0.168	7.743	0.0865	3.446	0.4450	0.330	737.	0.0909	777.	0.920
13	252.22	843.7	0.168	7.743	0.0955	3.681	0.4754	0.330	737.	0.0999	780.	0.923
14	252.12	843.7	0.168	7.740	0.1055	3.923	0.5069	0.330	738.	0.1099	782.	0.925
15	251.92	843.7	0.168	7.734	0.1160	4.195	0.5424	0.330	738.	0.1204	784.	0.928
16	251.82	843.7	0.168	7.731	0.1255	4.468	0.5780	0.329	738.	0.1299	786.	0.930
17	251.72	845.7	0.168	7.728	0.1360	4.743	0.6138	0.330	738.	0.1404	788.	0.933
18	251.52	843.7	0.168	7.722	0.1465	5.050	0.6540	0.330	738.	0.1509	790.	0.935
19	251.72	845.7	0.168	7.728	0.1565	5.397	0.6983	0.329	738.	0.1609	792.	0.937
20	251.52	843.7	0.168	7.722	0.1665	5.637	0.7300	0.329	738.	0.1709	794.	0.940
21	251.41	845.7	0.168	7.719	0.1760	5.972	0.7737	0.329	738.	0.1804	796.	0.942
22	251.21	845.7	0.167	7.713	0.1865	6.322	0.8197	0.329	738.	0.1909	797.	0.943
23	251.52	845.7	0.168	7.722	0.1965	6.660	0.8626	0.329	739.	0.2009	799.	0.946
24	251.31	843.7	0.168	7.716	0.2060	7.026	0.9107	0.329	739.	0.2104	800.	0.947
25	251.31	843.7	0.168	7.716	0.2260	7.774	1.0076	0.329	739.	0.2303	802.	0.949
26	251.11	843.7	0.167	7.710	0.2460	8.566	1.1111	0.329	739.	0.2503	803.	0.950
27	251.21	845.7	0.167	7.713	0.2665	9.451	1.2253	0.329	739.	0.2708	803.	0.950
28	250.91	843.7	0.167	7.703	0.2865	10.134	1.3155	0.328	739.	0.2908	803.	0.950
29	250.91	846.7	0.167	7.703	0.3055	10.793	1.4011	0.329	739.	0.3098	801.	0.948
30	250.91	846.7	0.167	7.703	0.3255	11.313	1.4686	0.329	739.	0.3298	800.	0.947
31	250.71	846.7	0.167	7.697	0.3465	11.672	1.5164	0.329	739.	0.3508	799.	0.946
32	250.71	843.7	0.167	7.697	0.3655	11.854	1.5400	0.328	739.	0.3698	794.	0.940

IV-6. Sample Data: On-Board Probe Flow-Field Data

LOOP	PO (PSIA)	TD (DEGR)	P(INF) (PSIA)	POP (PSIA)	ZP (IN)	PPD (PSIA)	PPN/POP	PH33 (PSIA)	TG1 (DEGR)	ZU (IN)	TDUM (DEGR)	TDUM/TO
33	250.81	843.7	0.167	7.700	0.3855	11.974	1.5550	0.329	740.	0.3898	793.	0.938
34	250.71	846.7	0.167	7.697	0.4065	12.014	1.5609	0.328	740.	0.4108	793.	0.938
35	250.51	846.7	0.167	7.691	0.4245	12.024	1.5633	0.328	740.	0.4288	793.	0.938
36	250.51	846.7	0.167	7.691	0.4465	12.025	1.5635	0.329	740.	0.4508	793.	0.938
37	250.31	843.7	0.167	7.685	0.4660	12.016	1.5636	0.328	740.	0.4703	793.	0.938
38	250.41	843.7	0.167	7.688	0.4860	12.013	1.5626	0.328	740.	0.4903	793.	0.938
39	250.31	846.7	0.167	7.685	0.5060	12.005	1.5622	0.328	740.	0.5103	792.	0.937
40	250.21	843.7	0.167	7.682	0.6045	11.989	1.5607	0.328	740.	0.6088	793.	0.938
41	250.31	846.7	0.167	7.685	0.7055	11.977	1.5585	0.328	740.	0.7097	792.	0.937
42	250.21	843.7	0.167	7.682	0.8055	11.936	1.5539	0.328	740.	0.8097	792.	0.937
43	250.21	843.7	0.167	7.682	0.9050	11.944	1.5548	0.328	740.	0.9092	792.	0.937
44	250.21	846.7	0.167	7.682	1.0050	11.960	1.5570	0.328	740.	1.0092	792.	0.937

MEAN VALUES

PO = 251.14 PSIA
 TD = 844.6 DEGR
 P(INF) = 0.1674 PSIA
 RE(INF) = 0.476E+07 PER FT
 MU(INF) = 0.841E-07 LBF-SEC/FT2
 U(INF) = 2982.1 FT/SEC
 Q(INF) = 4.150 PSIA
 T(INF) = 104.5 DEGR
 POP = 7.71 PSIA
 RHO(INF) = 0.134E-03 SLUGS/FT3

IV-6. Continued

PROJECT NO V41B-W6A
 SANSO/DOTR HYPERSONIC TURBULENT BOUNDARY LAYER INVESTIGATION
 PHASE II

GROUP 102 ALPHA MODEL = 0.05 DEG. DEN PT=-32.00 CONFIGURATION NOSE RADIUS, IN TRIP
 M(INF)= 5.95 ALPHA PM = 0.00 DEG. (DEG F) 7-DEG CONE SHARP NONE
 RE(INF)= 4.764E+06 PER FT ROLL = 0.04 DEG.

DATA TYPE
 ON-BOARD PROBE

PROBE STATION = 38.650 IN. STATION NO. = 1

LOOP	TG-1 DEGR	TG-2 DEGR	TG-3 DEGR	TG-4 DEGR	TG-5 DEGR	TG-6 DEGR	TG-7 DEGR	TG-8 DEGR	TG-9 DEGR	TG-10 DEGR	TG-11 DEGR	TG-12 DEGR	TG-13 DEGR	TG-14 DEGR	TG-15 DEGR	TG-16 DEGR	TG-17 DEGR	TG-18 DEGR	TG-19 DEGR
1	734.	734.		739.		742.	739.	743.	743.		745.	747.	749.	750.	752.		758.	734.	727.
2	734.	734.		739.		742.	739.	743.	743.		745.	747.	749.	750.	752.		758.	734.	728.
3	734.	734.		739.		743.	739.	743.	743.		745.	748.	749.	750.	752.		758.	735.	728.
4	735.	735.		739.		743.	739.	743.	743.		746.	748.	749.	750.	752.		758.	735.	728.
5	735.	734.		739.		743.	739.	743.	743.		746.	748.	749.	750.	752.		758.	735.	728.
6	735.	735.		740.		743.	739.	744.	744.		746.	748.	749.	751.	752.		759.	735.	729.
7	735.	735.		740.		743.	739.	744.	744.		746.	748.	749.	751.	752.		759.	735.	729.
8	735.	735.		740.		743.	739.	744.	744.		746.	748.	749.	751.	752.		759.	736.	729.
9	736.	736.		740.		743.	740.	744.	744.		746.	748.	749.	751.	752.		759.	736.	729.
10	736.	735.		740.		743.	740.	744.	744.		746.	748.	750.	751.	752.		759.	736.	729.
11	736.	736.		740.		744.	740.	744.	744.		747.	749.	750.	751.	752.		759.	736.	730.
12	737.	736.		741.		745.	741.	745.	745.		748.	749.	751.	752.	753.		760.	738.	731.
13	737.	737.		741.		745.	741.	745.	745.		748.	750.	751.	752.	753.		760.	738.	731.
14	739.	738.		741.		745.	741.	745.	745.		748.	750.	751.	752.	753.		761.	738.	731.
15	738.	737.		741.		745.	741.	745.	745.		748.	750.	751.	752.	753.		761.	738.	731.
16	738.	738.		742.		745.	741.	746.	746.		748.	750.	751.	752.	754.		761.	738.	732.
17	738.	738.		742.		745.	741.	746.	746.		748.	750.	751.	752.	754.		761.	738.	732.
18	738.	738.		742.		745.	741.	746.	746.		748.	750.	751.	752.	754.		761.	738.	732.
19	738.	738.		742.		745.	741.	746.	746.		748.	750.	751.	752.	754.		761.	738.	732.
20	738.	738.		742.		745.	741.	746.	746.		748.	750.	751.	752.	754.		761.	738.	732.
21	738.	738.		742.		745.	741.	746.	746.		748.	750.	751.	752.	754.		761.	739.	732.
22	738.	738.		742.		745.	742.	746.	746.		748.	750.	751.	753.	754.		761.	739.	732.
23	739.	738.		742.		745.	742.	746.	746.		749.	750.	751.	753.	754.		761.	739.	732.
24	739.	738.		742.		745.	742.	746.	746.		749.	750.	751.	753.	754.		761.	739.	732.
25	739.	738.		742.		745.	742.	746.	746.		749.	750.	751.	753.	754.		761.	739.	732.
26	739.	738.		742.		745.	742.	746.	746.		749.	750.	752.	753.	754.		761.	739.	733.
27	739.	739.		742.		746.	742.	746.	746.		749.	751.	752.	753.	754.		761.	739.	733.
28	739.	738.		742.		746.	742.	746.	746.		749.	751.	752.	753.	754.		761.	739.	733.
29	739.	739.		742.		746.	742.	746.	746.		749.	751.	752.	753.	754.		761.	739.	733.
30	739.	739.		742.		746.	742.	747.	747.		749.	751.	752.	753.	754.		762.	739.	733.
31	739.	739.		742.		746.	742.	747.	747.		749.	751.	752.	753.	754.		761.	740.	733.
32	739.	739.		742.		746.	742.	746.	747.		749.	751.	752.	753.	755.		762.	740.	733.
33	740.	739.		743.		746.	742.	747.	747.		749.	751.	752.	753.	754.		762.	740.	733.
34	740.	739.		743.		746.	742.	747.	747.		749.	751.	752.	753.	755.		762.	740.	733.
35	740.	739.		743.		746.	742.	747.	747.		749.	751.	752.	753.	755.		762.	740.	733.
36	740.	739.		743.		746.	742.	747.	747.		749.	751.	752.	753.	754.		762.	740.	733.
37	740.	739.		743.		746.	742.	747.	747.		749.	751.	752.	753.	755.		762.	740.	734.
38	740.	739.		743.		746.	742.	747.	747.		749.	751.	752.	753.	755.		762.	740.	734.
39	740.	739.		743.		746.	742.	747.	747.		749.	751.	752.	753.	755.		762.	740.	734.
40	740.	739.		743.		746.	742.	747.	747.		749.	751.	752.	753.	755.		762.	740.	734.
41	740.	740.		743.		746.	742.	747.	747.		750.	751.	752.	753.	755.		762.	740.	734.

IV-6. Continued

LOOP	TG-1 DEGR	TG-2 DEGR	TG-3 DEGR	TG-4 DEGR	TG-5 DEGR	TG-6 DEGR	TG-7 DEGR	TG-8 DEGR	TG-9 DEGR	TG-10 DEGR	TG-11 DEGR	TG-12 DEGR	TG-13 DEGR	TG-14 DEGR	TG-15 DEGR	TG-16 DEGP	TG-17 DEGR	TG-18 DEGR	TG-19 DEGR
42	740.	740.		743.		746.	743.	747.	747.		750.	751.	752.	754.	755.		762.	740.	734.
43	740.	740.		743.		746.	743.	747.	747.		750.	751.	752.	754.	755.		762.	740.	734.
44	740.	740.		743.		746.	743.	747.	747.		750.	751.	752.	754.	755.		762.	740.	734.

PROJECT NO V418-W6A
 SAMSO/DOIR HYPERSONIC TURBULENT BOUNDARY LAYER INVESTIGATION
 PHASE II

GROUP 102 ALPHA MODEL = 0.05 DEG. DEN PT=-32.00 CONFIGURATION NOSE RADIUS, IN TRIP
 N(INF)= 5.95 ALPHA PB = 0.00 DEG. (DEG F) 7-DEG CONE SHARP NONE
 RE(INF)= 4.764E+06 PER FT ROLL = 0.04 DEG.

UNSHIELDED TEMPERATURE PROBE CORRECTIONS PROBE STATION = 38.650 IN. STATION NO. = 1
 ON-BOARD PROBE

LOOP	ZU (IN)	PO (PSIA)	TO (DEGR)	PPU (PSIA)	PPU/PO	MUI	REU	ETA	YOUN/TO	TOUI (DEGR)	TOUI/TO	UII (FT/SEC)
1	0.0104	250.91	841.7	0.684	0.0027	1.08	48.56	0.926	0.899	770.	0.912	1324.04
2	0.0129	250.81	842.7	0.756	0.0030	1.16	52.74	0.926	0.901	773.	0.915	1404.45
3	0.0184	251.11	841.7	1.128	0.0045	1.50	72.28	0.926	0.902	780.	0.923	1708.21
4	0.0229	251.01	844.7	1.636	0.0065	1.86	95.82	0.926	0.903	787.	0.931	1969.11
5	0.0259	251.21	844.7	1.775	0.0071	1.95	101.87	0.926	0.904	789.	0.934	2024.85
6	0.0319	251.31	845.7	2.046	0.0081	2.11	113.70	0.926	0.904	791.	0.937	2116.65
7	0.0409	251.62	844.7	2.365	0.0094	2.28	126.93	0.926	0.906	796.	0.942	2209.04
8	0.0509	251.62	845.7	2.618	0.0104	2.41	137.41	0.926	0.908	798.	0.945	2271.23
9	0.0599	251.92	845.7	2.826	0.0112	2.51	145.59	0.926	0.910	802.	0.949	2316.13
10	0.0714	251.82	842.7	3.072	0.0122	2.62	155.05	0.926	0.914	806.	0.955	2369.54
11	0.0809	251.92	842.7	3.297	0.0131	2.72	163.71	0.926	0.916	809.	0.958	2410.90
12	0.0909	252.22	845.7	3.561	0.0141	2.84	173.53	0.926	0.920	814.	0.963	2455.92
13	0.0999	252.22	843.7	3.787	0.0150	2.93	181.78	0.926	0.923	818.	0.968	2492.14
14	0.1099	252.12	843.7	4.037	0.0160	3.03	191.16	0.926	0.925	821.	0.972	2527.11
15	0.1204	251.92	843.7	4.321	0.0172	3.14	201.77	0.926	0.928	824.	0.976	2562.97
16	0.1299	251.82	843.7	4.583	0.0182	3.23	211.39	0.926	0.930	827.	0.979	2593.56
17	0.1404	251.72	845.7	4.871	0.0194	3.34	221.95	0.926	0.933	830.	0.983	2624.27
18	0.1509	251.52	843.7	5.201	0.0207	3.45	234.06	0.926	0.935	833.	0.986	2656.13
19	0.1609	251.72	845.7	5.502	0.0219	3.56	244.99	0.926	0.937	836.	0.990	2683.24
20	0.1709	251.52	843.7	5.791	0.0230	3.65	255.33	0.926	0.940	839.	0.993	2707.50
21	0.1804	251.41	845.7	6.117	0.0243	3.75	267.02	0.926	0.942	842.	0.996	2732.56
22	0.1909	251.21	845.7	6.469	0.0258	3.86	280.00	0.926	0.943	843.	0.999	2755.62
23	0.2009	251.52	845.7	6.828	0.0271	3.97	292.74	0.926	0.946	846.	1.002	2778.99
24	0.2104	251.31	843.7	7.189	0.0286	4.08	305.94	0.926	0.947	849.	1.004	2794.11
25	0.2303	251.31	843.7	7.946	0.0316	4.29	333.59	0.926	0.949	851.	1.008	2836.70
26	0.2503	251.11	843.7	8.753	0.0349	4.51	363.33	0.926	0.950	853.	1.010	2869.13
27	0.2708	251.21	845.7	9.599	0.0382	4.73	394.97	0.926	0.950	854.	1.011	2896.46
28	0.2908	250.91	843.7	10.284	0.0410	4.89	420.59	0.926	0.950	855.	1.012	2915.73
29	0.3098	250.91	846.7	10.906	0.0435	5.04	445.24	0.926	0.948	853.	1.010	2927.77
30	0.3298	250.91	846.7	11.387	0.0454	5.15	463.96	0.926	0.947	853.	1.010	2936.98
31	0.3508	250.71	846.7	11.713	0.0467	5.23	476.90	0.926	0.946	852.	1.009	2942.17
32	0.3698	250.71	843.7	11.880	0.0474	5.27	486.77	0.926	0.940	847.	1.002	2936.38

IV-6. Continued

LOOP	ZU (IN)	PO (PSIA)	TO (DEGR)	PPU (PSIA)	PPU/PO	MUI	REU	ETA	TOUN/TO	TQOI (DEGR)	TQOI/TO	UUI (FT/SEC)
33	0.3898	250.81	843.7	11.982	0.0478	5.29	491.39	0.926	0.938	846.	1.001	2936.60
34	0.4108	250.71	846.7	12.017	0.0479	5.30	492.69	0.926	0.938	846.	1.001	2937.29
35	0.4288	250.51	846.7	12.024	0.0480	5.30	492.96	0.926	0.938	846.	1.001	2937.44
36	0.4508	250.51	846.7	12.023	0.0480	5.30	492.93	0.926	0.938	846.	1.001	2937.42
37	0.4703	250.31	843.7	12.015	0.0480	5.30	492.64	0.926	0.938	846.	1.001	2937.27
38	0.4903	250.41	843.7	12.011	0.0480	5.30	492.49	0.926	0.938	846.	1.001	2937.19
39	0.5103	250.31	846.7	12.005	0.0480	5.29	492.98	0.926	0.937	845.	1.000	2935.20
40	0.6088	250.21	843.7	11.988	0.0479	5.29	491.62	0.926	0.938	846.	1.001	2936.73
41	0.7097	250.31	846.7	11.975	0.0478	5.29	491.86	0.926	0.937	845.	1.000	2934.61
42	0.8097	250.21	843.7	11.937	0.0477	5.28	490.40	0.926	0.937	845.	1.000	2933.83
43	0.9092	250.21	843.7	11.945	0.0477	5.28	490.70	0.926	0.937	845.	1.000	2933.99
44	1.0092	250.21	846.7	12.009	0.0480	5.29	493.13	0.926	0.937	845.	1.000	2935.28

CALIBRATION CONSTANTS

A0= 9.360E-01 A1= 0.000E+00 A2= 0.000E+00 A3= 0.000E+00 A4= 0.000E+00

MEAN VALUES

PO = 251.14 PSIA	U(INF)= 2982.1 FT/SEC
TO = 844.6 DEGR	Q(INF)= 4.150 PSIA
P(INF)= 0.1674 PSIA	T(INF)= 104.5 DEGR
RE(INF)= 0.476E+07 PER FT	POP = 7.71 PSIA
MU(INF)= 0.841E-07 LBF-SEC/FT2	RHO(INF)= 0.134E-03 SLUGS/FT3

ARO, INC - AEDC DIVISION
A SVERDRUP CORPORATION COMPANY
VON KARMAN GAS DYNAMICS FACILITY
ARNOLD AIR FORCE STATION, TENN

DATE COMPUTED 30-JUN-78
DATE RECORDED 13-APR-78
TIME RECORDED 23:40: 6

PROJECT NO V41B-W6A
SAMSO/DOTR HYPERSONIC TURBULENT BOUNDARY LAYER INVESTIGATION
PHASE II

GROUP 102 ALPHA MODEL = 0.05 DEG. DEW PT=-32.00 CONFIGURATION NOSE RADIUS, IN TRIP
N(INF)= 5.95 ALPHA PB = 0.00 DEG. (DEG F) 7-DEG CONE SHARP NONE
RE(INF)= 4.764E+06 PER FT ROLL = 0.04 DEG.

DATA TYPE
ON-BOARD PROBE

PROBE STATION = 38.650 IN. STATION NO. = 1

BOUNDARY LAYER VALUES

DEL1 = 0.3937 IN.
DEL2 = 0.1594 IN.
DEL3 = 0.0120 IN.
DEL4 = IN.
DEL5 = IN.
NU1 = 13.2546
NU2 = 0.0000
TEU = 846.8 DEGR
UUE = 2936.0 FT PER SECOND
RHOU = 2.149E-04 SLUGS PER FT3

MEAN VALUES
PO = 251.14 PSIA U(INF)= 2982.1 FT/SEC
TO = 844.6 DEGR Q(INF)= 4.150 PSIA
P(INF)= 0.1674 PSIA T(INF)= 104.5 DEGR
RE(INF)= 0.476E+07 PER FT POP = 7.71 PSIA
MU(INF)= 0.841E-07 LBF-SEC/FT2 RHQ(INF)= 0.136E-03 SLUGS/FT3

IV-7. NOMENCLATURE: OVERHEAD PROBE FLOW-FIELD DATA

PRINTOUT PAGE ONE

ALPHA MODEL	Model angle of attack, deg
ALPHA PB	Support sting prebend angle, deg
CONFIGURATION	Model configuration (see Fig. 2)
DATA TYPE	Type of data tabulated
DEW PT	Free-stream flow frost point, °F
GROUP	Data group number
LOOP	Data point identification number
M(INF)	Free-stream Mach number
MU(INF)	Free-stream viscosity, lbf-sec/ft ²
NOSE RADIUS	Model nose tip radius, in.
P(INF), PINF	Free-stream static pressure, psia
PO	Tunnel stilling chamber pressure, psia
POP	Free-stream total pressure downstream of a normal shock, psia
POO	On-board probe pitot pressure, psia
PRESO	Preston tube pressure, psia
PROBE STATION	Probe station location measured along model surface from model nose tip, in.
PWX	Model wall pressure at the survey station (X), psia
Q(INF)	Free-stream dynamic pressure, psia
RE(INF)	Free-stream Reynolds number, per foot
RHO(INF)	Free-stream density, slugs/ft ³
ROLL	Model roll angle, deg
T(INF)	Free-stream static temperature, °R
TAUWO	Shear stress at the model wall, psf

TO	Tunnel stilling chamber temperature, °R
TOUM	Unshielded thermocouple probe reading, °R
TRIP	Boundary-layer trip configuration - sphere and grit dimensions stated in inches
TW1	Model wall temperature at probe survey station, °R
U(INF)	Free-stream velocity, ft/sec
XP	Probe axial position in digital counts
ZO	Pitot probe height above model surface, in.
ZOT	Height of unshielded thermocouple probe above model surface, in.

PRINTOUT PAGE TWO

All heading information is identical to page one.

TG-1 to TG-19.	Gardon gage case temperature, °R
----------------	----------------------------------

PRINTOUT PAGE THREE (Unshielded Temperature Probe Correction)

All heading information is identical to page one.

A00 to A04	Calibration constants (unique to individual probe)
ETA0	Probe calibration function
LOOP	Data point identification number
MOI	Local Mach number at survey point
PO	Tunnel stilling chamber pressure, psia
POOI	Local interpolated pitot pressure, psia
ROD	Local Reynolds number at survey point
TO	Tunnel stilling chamber temperature, °R
TOOI, TOO	Local corrected and uncorrected total temperature, respectively, at a survey point, °R
UOI	Local flow velocity at survey point, ft/sec
ZOT	Height of unshielded thermocouple probe above model surface, in.

PRINTOUT PAGE FOUR (Boundary Layer Values)

DEL	Boundary-layer thickness, in.
DEL*	Displacement thickness, in.
DEL2	Momentum thickness, in.
DEL3	Kinetic energy defect, in.
DEL4	Total enthalpy defect, in.
H1	Shape factor, $DE^*/DEL2$
H2	Shape factor, $DEL/DEL3$
MTAUO	Friction Mach number
RHOED	Flow density at boundary-layer edge, slugs/ft ³
RTAUO	Calibration parameter
TED	Total temperature at boundary-layer edge, °R
UOED	Flow velocity at boundary-layer edge, ft/sec

All other parameters such as PTAUO and F10 are defined in Appendix III.

PROJECT NO V41B-W6A
 NASA/DOTR HYPERSONIC TURBULENT BOUNDARY LAYER INVESTIGATION
 PHASE II

GROUP 106 ALPHA MODEL = 0.01 DEG. DEW PT=-32.00 CONFIGURATION NOSE RADIUS,IN TRIP
 N(INF)= 5.99 ALPHA PD = 0.00 DEG. (DEG F) 7-DEG CONE SHARP NONE
 RE(INF)= 4.744E+06 PER FT ROLL = -89.96 DEG.

DATA TYPE
 OVERHEAD PROBE

PROBE STATION = 38.650 IN. STATION NO. = 1

LOOP	PD (PSIA)	TO (DEGR)	PINF (PSIA)	POP (PSIA)	ZO (IN)	POO (PSIA)	PDO/POP	ZOT (IN)	TOO (DEGR)	TOO/TO	PW33 (PSIA)	TW 1 (DEGR)	PRESO (PSIA)	TAUM (PSF)
1	251.41	845.7	0.160	7.719	0.0060	0.666	0.0862	0.0101	759.	0.895	0.329	741.	1.038	1.050
2	251.41	847.7	0.160	7.719	0.0090	0.655	0.0848	0.0131	762.	0.900	0.329	741.		
3	251.52	844.7	0.160	7.722	0.0145	0.652	0.0844	0.0186	766.	0.905	0.330	741.		
4	251.52	844.7	0.160	7.722	0.0210	0.896	0.1160	0.0251	768.	0.907	0.330	741.		
5	251.73	844.7	0.160	7.728	0.0240	1.120	0.1449	0.0281	768.	0.907	0.330	741.		
6	251.21	844.7	0.167	7.713	0.0455	2.360	0.3059	0.0496	770.	0.909	0.329	741.		
7	251.31	847.7	0.168	7.716	0.0560	2.587	0.3352	0.0601	771.	0.911	0.329	741.		
8	251.21	847.7	0.167	7.713	0.0665	2.935	0.3676	0.0706	772.	0.912	0.329	741.		
9	251.21	847.7	0.167	7.713	0.0770	3.067	0.3976	0.0811	774.	0.914	0.329	741.		
10	251.21	844.7	0.167	7.713	0.0865	3.275	0.4247	0.0906	776.	0.916	0.329	741.		
11	251.11	847.7	0.167	7.710	0.0965	3.521	0.4567	0.1006	778.	0.919	0.329	741.		
12	251.11	847.7	0.167	7.710	0.1065	3.769	0.4889	0.1106	780.	0.921	0.329	741.		
13	251.11	845.7	0.167	7.710	0.1175	4.049	0.5252	0.1215	782.	0.924	0.329	741.		
14	251.01	845.7	0.167	7.706	0.1250	4.282	0.5556	0.1290	784.	0.926	0.329	741.		
15	251.21	844.7	0.167	7.713	0.1365	4.555	0.5906	0.1405	786.	0.928	0.329	741.		
16	251.01	844.7	0.167	7.706	0.1465	4.821	0.6256	0.1505	788.	0.931	0.329	741.		
17	250.91	847.7	0.167	7.703	0.1575	5.121	0.6647	0.1615	789.	0.932	0.329	741.		
18	251.01	845.7	0.167	7.706	0.1665	5.423	0.7037	0.1705	791.	0.934	0.329	741.		
19	251.01	844.7	0.167	7.706	0.1775	5.729	0.7434	0.1815	793.	0.937	0.329	741.		
20	251.01	847.7	0.167	7.706	0.1875	6.005	0.7793	0.1915	794.	0.938	0.329	741.		
21	250.91	845.7	0.167	7.703	0.2080	6.754	0.8768	0.2120	797.	0.941	0.329	741.		
22	250.91	845.7	0.167	7.703	0.2280	7.443	0.9662	0.2320	799.	0.944	0.329	741.		
23	251.01	846.7	0.167	7.706	0.2485	8.227	1.0676	0.2525	801.	0.946	0.329	741.		
24	251.01	845.7	0.167	7.706	0.2680	9.041	1.1732	0.2720	801.	0.946	0.329	741.		
25	251.01	847.7	0.167	7.706	0.2885	9.799	1.2716	0.2925	801.	0.946	0.329	741.		
26	250.91	847.7	0.167	7.703	0.3080	10.527	1.3665	0.3120	799.	0.944	0.329	741.		
27	250.81	847.7	0.167	7.700	0.3080	10.518	1.3659	0.3120	799.	0.944	0.328	741.		
28	250.61	845.7	0.167	7.694	0.3080	10.510	1.3660	0.3120	799.	0.944	0.328	741.		
29	250.91	845.7	0.167	7.703	0.3080	10.524	1.3661	0.3120	799.	0.944	0.328	741.		
30	250.81	847.7	0.167	7.700	0.3080	10.533	1.3679	0.3120	799.	0.944	0.328	741.		
31	250.81	845.7	0.167	7.700	0.3290	11.132	1.4457	0.3330	797.	0.941	0.328	741.		
32	250.61	845.7	0.167	7.694	0.3295	11.111	1.4440	0.3335	798.	0.942	0.329	741.		
33	250.71	847.7	0.167	7.697	0.3295	11.134	1.4465	0.3335	797.	0.941	0.328	741.		

IV-8. Sample Data: Overhead Probe Flow-Field Data

LOOP	PO (PSIA)	TO (DEGR)	PINF (PSIA)	POP (PSIA)	EO (IN)	POD (PSIA)	POD/POP	EOT (IN)	TOO (DEGR)	TOO/TO	PN33 (PSIA)	TW 1 (DEGR)	PRESO (PSIA)	TAUNG (PSF)
34	250.51	845.7	0.167	7.691	0.3490	11.549	1.5016	0.3530	796.	0.940	0.328	741.		
35	250.91	844.7	0.167	7.703	0.3705	11.815	1.5337	0.3745	795.	0.939	0.328	741.		
36	250.51	845.7	0.167	7.691	0.3695	11.963	1.5554	0.3935	794.	0.938	0.328	741.		
37	250.61	847.7	0.167	7.694	0.4100	12.045	1.5655	0.4140	794.	0.938	0.329	741.		
38	250.61	847.7	0.167	7.694	0.4295	12.065	1.5681	0.4335	794.	0.938	0.328	741.		
39	250.61	847.7	0.167	7.694	0.4495	12.077	1.5697	0.4535	794.	0.938	0.328	741.		
40	250.31	845.7	0.167	7.685	0.4705	12.063	1.5698	0.4745	794.	0.938	0.328	741.		
41	250.31	847.7	0.167	7.688	0.4690	12.060	1.5694	0.4730	794.	0.938	0.328	741.		
42	250.31	845.7	0.167	7.685	0.4910	12.048	1.5677	0.4950	794.	0.938	0.328	741.		
43	250.51	845.7	0.167	7.691	0.5095	12.057	1.5677	0.5135	794.	0.938	0.328	741.		
44	250.41	847.7	0.167	7.688	0.6100	12.043	1.5665	0.6140	793.	0.937	0.328	741.		
45	250.01	847.7	0.167	7.676	0.7090	12.017	1.5656	0.7129	793.	0.937	0.328	741.		
46	250.21	847.7	0.167	7.682	0.8095	11.989	1.5607	0.8134	794.	0.938	0.328	741.		
47	250.41	845.7	0.167	7.688	0.9120	11.995	1.5503	0.9159	793.	0.937	0.328	741.		
48	250.31	848.7	0.167	7.685	1.0120	12.009	1.5627	1.0159	793.	0.937	0.328	741.		
49	250.31	847.7	0.167	7.685	1.2625	12.054	1.5686	1.2663	793.	0.937	0.328	741.		
50	250.31	845.7	0.167	7.685	1.5145	11.876	1.5454	1.5183	791.	0.934	0.328	741.		
51	250.21	847.7	0.167	7.682	1.7650	11.696	1.5225	1.7688	790.	0.933	0.327	741.		
52	250.11	845.7	0.167	7.679	2.0145	11.694	1.5230	2.0183	790.	0.933	0.327	741.		

MEAN VALUES

PO = 250.82 PSIA

TO = 846.4 DEGR

P(INF) = 0.1672 PSIA

RE(INF) = 0.474E+07 PER FT

MU(INF) = 0.843E-07 LBF-SEC/FT²

XP = 6324. CTS

U(INF) = 2985.2 FT/SEC

O(INF) = 4.144 PSIA

T(INF) = 104.7 DEGR

POP = 7.70 PSIA

RHO(INF) = 0.136E-03 SLUGS/FT³

IV-8.

Continued

PROJECT NO V41B-W4A
 BANSO/DOTR HYPERSONIC TURBULENT BOUNDARY LAYER INVESTIGATION
 PHASE II

GROUP 106 ALPHA MODEL = 0.01 DEG. DEW PT = -32.00 CONFIGURATION NOSE RADIUS, IN TRIP
 N(INF) = 5.95 ALPHA PB = 0.00 DEG. (DEG F) 7-DEG CONE SHARP NONE
 RE(INF) = 4.746E+06 PER FT ROLL = -89.96 DEG.

DATA TYPE
 OVERHEAD PROBE

PROBE STATION = 32.650 IN. STATION NO. = 1

LOOP	TG-1 DEGR	TG-2 DEGR	TG-3 DEGR	TG-4 DEGR	TG-5 DEGR	TG-6 DEGR	TG-7 DEGR	TG-8 DEGR	TG-9 DEGR	TG-10 DEGR	TG-11 DEGR	TG-12 DEGR	TG-13 DEGR	TG-14 DEGR	TG-15 DEGR	TG-16 DEGR	TG-17 DEGR	TG-18 DEGR	TG-19 DEGR
1	741.	741.	186.	744.	800.	745.	742.	748.	749.	851.	751.	755.	753.	754.	756.	920.	763.	743.	736.
2	741.	741.	186.	744.	802.	745.	742.	748.	749.	851.	751.	755.	753.	754.	756.	920.	763.	743.	736.
3	741.	741.	186.	744.	803.	745.	742.	748.	749.	851.	751.	755.	753.	754.	755.	920.	763.	743.	736.
4	741.	741.	186.	744.	804.	745.	742.	748.	749.	851.	751.	755.	753.	754.	756.	920.	763.	743.	736.
5	741.	741.	186.	744.	805.	745.	742.	748.	749.	851.	751.	754.	753.	754.	756.	920.	763.	743.	736.
6	741.	741.	186.	744.	815.	745.	742.	748.	749.	851.	751.	754.	753.	754.	756.	920.	763.	743.	736.
7	741.	741.	186.	744.	815.	745.	742.	748.	749.	851.	751.	754.	753.	754.	756.	920.	763.	743.	736.
8	741.	741.	186.	744.	815.	745.	742.	748.	749.	851.	751.	754.	753.	754.	756.	920.	763.	743.	736.
9	741.	741.	186.	744.	816.	745.	742.	748.	749.	851.	751.	754.	753.	754.	756.	920.	763.	743.	736.
10	741.	741.	186.	744.	817.	745.	742.	748.	749.	851.	751.	754.	753.	754.	756.	920.	763.	743.	736.
11	741.	741.	186.	744.	817.	745.	742.	748.	749.	851.	751.	754.	753.	754.	756.	920.	763.	743.	736.
12	741.	741.	186.	744.	818.	745.	742.	748.	749.	851.	751.	754.	753.	754.	756.	920.	763.	743.	736.
13	741.	741.	186.	744.	818.	745.	742.	748.	749.	851.	751.	754.	753.	754.	756.	920.	763.	743.	736.
14	741.	742.	186.	744.	819.	745.	742.	748.	749.	851.	751.	754.	753.	754.	756.	920.	763.	743.	736.
15	741.	741.	186.	744.	819.	745.	742.	748.	749.	851.	751.	754.	753.	754.	756.	920.	763.	743.	736.
16	741.	741.	186.	744.	820.	745.	742.	748.	749.	851.	751.	754.	753.	754.	756.	920.	763.	743.	736.
17	741.	741.	186.	744.	820.	745.	742.	748.	749.	851.	751.	754.	753.	754.	756.	920.	763.	743.	736.
18	741.	741.	186.	744.	821.	745.	742.	748.	749.	851.	751.	754.	753.	754.	756.	920.	763.	743.	736.
19	741.	741.	186.	744.	822.	745.	742.	748.	749.	851.	751.	754.	753.	754.	756.	920.	763.	743.	736.
20	741.	741.	186.	744.	822.	745.	742.	748.	749.	851.	751.	754.	753.	754.	756.	920.	763.	743.	736.
21	741.	741.	186.	744.	822.	745.	743.	748.	749.	851.	751.	754.	753.	755.	756.	920.	763.	743.	736.
22	741.	741.	186.	744.	823.	745.	742.	748.	749.	851.	751.	754.	753.	754.	756.	920.	763.	743.	736.
23	741.	741.	186.	744.	823.	745.	742.	748.	749.	851.	751.	754.	753.	754.	756.	920.	763.	743.	736.
24	741.	741.	186.	744.	824.	745.	742.	748.	749.	851.	751.	754.	753.	754.	756.	920.	763.	743.	736.
25	741.	741.	186.	744.	824.	745.	742.	748.	749.	851.	751.	754.	753.	754.	756.	920.	763.	743.	736.
26	741.	741.	186.	744.	824.	745.	742.	748.	749.	851.	751.	754.	753.	754.	756.	920.	763.	744.	736.
27	741.	742.	186.	744.	824.	745.	742.	748.	749.	851.	751.	754.	753.	755.	756.	920.	763.	743.	736.
28	741.	741.	186.	744.	823.	745.	742.	748.	749.	851.	751.	754.	753.	754.	756.	920.	763.	743.	736.
29	741.	741.	186.	744.	823.	745.	742.	748.	749.	851.	751.	754.	753.	754.	756.	920.	763.	743.	736.
30	741.	741.	186.	744.	823.	745.	742.	748.	749.	851.	751.	754.	753.	754.	756.	920.	763.	743.	736.
31	741.	741.	186.	744.	823.	745.	743.	748.	749.	851.	751.	754.	753.	754.	756.	920.	763.	743.	736.
32	741.	741.	186.	744.	823.	745.	742.	748.	749.	851.	751.	754.	753.	754.	756.	920.	763.	743.	736.
33	741.	741.	186.	744.	823.	745.	742.	748.	749.	851.	751.	754.	753.	754.	756.	920.	763.	743.	736.
34	741.	741.	186.	744.	823.	745.	742.	748.	749.	851.	751.	754.	753.	755.	756.	920.	763.	743.	736.
35	741.	741.	186.	744.	823.	745.	743.	748.	749.	851.	751.	754.	753.	755.	756.	920.	763.	743.	736.
36	741.	741.	186.	744.	823.	745.	743.	748.	749.	851.	751.	754.	753.	754.	756.	920.	763.	743.	736.
37	741.	741.	186.	744.	823.	745.	743.	748.	749.	851.	751.	754.	753.	755.	756.	920.	763.	743.	736.
38	741.	741.	186.	744.	823.	745.	743.	748.	749.	851.	751.	754.	753.	755.	756.	920.	763.	743.	736.
39	741.	741.	186.	744.	823.	745.	742.	748.	749.	851.	751.	754.	753.	755.	756.	920.	763.	743.	736.
40	741.	741.	186.	744.	822.	745.	743.	748.	749.	851.	751.	754.	753.	755.	756.	920.	763.	743.	736.
41	741.	742.	186.	744.	822.	745.	743.	748.	749.	851.	751.	754.	753.	755.	756.	920.	763.	743.	736.

IV-8. Continued

LOOP	TG-1 DEGR	TG-2 DEGR	TG-3 DEGR	TG-4 DEGR	TG-5 DEGR	TG-6 DEGR	TG-7 DEGR	TG-8 DEGR	TG-9 DEGR	TG-10 DEGR	TG-11 DEGR	TG-12 DEGR	TG-13 DEGR	TG-14 DEGR	TG-15 DEGR	TG-16 DEGR	TG-17 DEGR	TG-18 DEGR	TG-19 DEGR
42	741.	742.	186.	744.	821.	745.	743.	748.	749.	851.	751.	754.	754.	755.	756.	920.	763.	743.	736.
43	741.	741.	186.	744.	821.	746.	743.	748.	749.	851.	751.	754.	754.	755.	756.	920.	763.	743.	737.
44	741.	741.	186.	744.	820.	746.	743.	748.	749.	851.	751.	754.	754.	755.	756.	920.	763.	743.	736.
45	741.	741.	186.	744.	820.	745.	743.	748.	749.	851.	751.	754.	754.	755.	756.	920.	763.	744.	736.
46	741.	741.	186.	744.	819.	745.	743.	748.	749.	851.	751.	754.	754.	755.	756.	920.	763.	743.	736.
47	741.	742.	186.	744.	820.	746.	743.	748.	749.	851.	751.	754.	754.	755.	756.	920.	763.	744.	737.
48	741.	741.	186.	744.	820.	746.	743.	748.	749.	851.	751.	754.	754.	755.	756.	920.	763.	744.	736.
49	741.	742.	186.	744.	821.	746.	743.	748.	749.	851.	751.	754.	754.	755.	756.	920.	763.	744.	737.
50	741.	741.	186.	744.	821.	746.	743.	748.	749.	851.	751.	754.	754.	755.	756.	920.	763.	744.	737.
51	741.	742.	186.	744.	822.	746.	743.	748.	749.	851.	751.	754.	754.	755.	756.	920.	763.	743.	737.
52	741.	741.	186.	744.	822.	746.	743.	748.	749.	851.	751.	754.	754.	755.	756.	920.	763.	743.	736.

PROJECT NO V418-N6A
 BANSO/DOIR HYPERSONIC TURBULENT BOUNDARY LAYER INVESTIGATION
 PHASE II

GROUP 106 ALPHA MODEL = 0.01 DEG. DEN PT=-32.00 CONFIGURATION NOSE RADIUS, IN TRIP
 N(INF)= 5.95 ALPHA PB = 0.00 DEG. (DEG F) 7-DEG CONE SHARP NONE
 RE(INF)= 4.744E+06 PER FT ROLL = -89.96 DEG.

UNSHIELDED TEMPERATURE PROBE CORRECTIONS PROBE STATION = 38.650 IN. STATION NO. = 1
 OVERHEAD PROBE

LOOP	ZOT (IN)	PO (PSIA)	TO (DEGR)	POOI (PSIA)	POOI/PO	NOI	ROD	ETAO	TOO/TO	TOOI (DEGR)	TOOI/TO	UOI (FT/SEC)
1	0.0101	251.41	845.7	0.654	0.0026	1.05	46.69	0.918	0.895	769.	0.909	1287.71
2	0.0131	251.41	847.7	0.652	0.0026	1.04	46.29	0.918	0.900	773.	0.913	1288.89
3	0.0186	251.52	844.7	0.804	0.0032	1.21	54.88	0.918	0.905	780.	0.922	1460.56
4	0.0281	251.52	844.7	1.181	0.0047	1.55	73.86	0.918	0.907	789.	0.932	1751.76
5	0.0281	251.72	844.7	1.354	0.0054	1.68	81.98	0.918	0.907	791.	0.934	1849.81
6	0.0496	251.31	844.7	2.447	0.0097	2.33	128.99	0.919	0.909	804.	0.949	2241.42
7	0.0601	251.31	847.7	2.683	0.0107	2.45	138.50	0.919	0.911	806.	0.953	2297.16
8	0.0706	251.21	847.7	2.925	0.0116	2.56	148.16	0.919	0.912	809.	0.956	2348.06
9	0.0811	251.21	847.7	3.156	0.0126	2.67	157.12	0.919	0.914	812.	0.960	2393.56
10	0.0906	251.21	844.7	3.375	0.0134	2.76	165.42	0.919	0.916	815.	0.963	2432.77
11	0.1006	251.11	847.7	3.622	0.0144	2.86	174.74	0.919	0.919	819.	0.967	2472.78
12	0.1106	251.11	847.7	3.872	0.0154	2.97	184.11	0.920	0.921	822.	0.971	2509.87
13	0.1216	251.11	845.7	4.175	0.0166	3.09	195.50	0.920	0.924	825.	0.975	2550.14
14	0.1290	251.01	845.7	4.378	0.0174	3.16	202.85	0.920	0.926	828.	0.978	2578.00
15	0.1408	251.21	844.7	4.663	0.0186	3.27	213.29	0.920	0.928	831.	0.982	2608.36
16	0.1503	251.01	844.7	4.931	0.0196	3.36	223.00	0.920	0.931	834.	0.985	2636.70
17	0.1615	250.91	847.7	5.256	0.0209	3.48	235.18	0.920	0.932	836.	0.988	2666.01
18	0.1708	251.01	845.7	5.535	0.0221	3.57	245.24	0.920	0.934	839.	0.991	2691.21
19	0.1818	251.01	844.7	5.841	0.0233	3.67	256.14	0.920	0.937	842.	0.995	2716.39
20	0.1918	251.01	847.7	6.153	0.0245	3.77	267.63	0.920	0.938	843.	0.997	2738.57
21	0.2120	250.91	845.7	6.893	0.0275	4.00	294.39	0.920	0.941	848.	1.002	2786.17
22	0.2320	250.91	845.7	7.597	0.0303	4.20	320.08	0.921	0.944	851.	1.006	2823.68
23	0.2525	251.01	846.7	8.395	0.0334	4.42	349.01	0.921	0.946	855.	1.010	2859.78
24	0.2720	251.01	845.7	9.190	0.0366	4.63	378.72	0.921	0.946	856.	1.011	2887.30
25	0.2928	251.01	847.7	9.949	0.0396	4.82	407.08	0.921	0.946	856.	1.012	2909.98
26	0.3120	250.91	847.7	10.647	0.0424	4.99	434.56	0.921	0.944	855.	1.010	2924.72
27	0.3120	250.81	847.7	10.647	0.0425	4.99	434.56	0.921	0.944	855.	1.010	2924.72
28	0.3120	250.61	845.7	10.647	0.0425	4.99	434.56	0.921	0.944	855.	1.010	2924.72
29	0.3120	250.91	845.7	10.647	0.0424	4.99	434.56	0.921	0.944	855.	1.010	2924.72
30	0.3120	250.81	847.7	10.647	0.0425	4.99	434.56	0.921	0.944	855.	1.010	2924.72
31	0.3120	250.81	845.7	11.210	0.0447	5.12	456.93	0.921	0.941	853.	1.008	2934.25
32	0.3338	250.61	845.7	11.210	0.0449	5.12	456.64	0.921	0.942	854.	1.009	2936.34

IV-8. Continued

LOOP	ZOT (IN)	PO (PSIA)	TO (DEGR)	POOI (PSIA)	POOI/PO	MOI	RDD	ETAO	TOO/TO	TOOI (DEGR)	TOOI/TO	UOI (FT/SEC)
33	0.3338	250.71	847.7	11.219	0.0447	5.12	457.33	0.921	0.941	853.	1.008	2934.49
34	0.3530	250.51	845.7	11.598	0.0463	5.21	472.20	0.921	0.940	852.	1.007	2940.91
35	0.3745	250.91	844.7	11.846	0.0472	5.26	482.31	0.921	0.939	851.	1.006	2944.19
36	0.3935	250.51	845.7	11.979	0.0478	5.29	488.05	0.921	0.938	850.	1.005	2945.01
37	0.4140	250.61	847.7	12.049	0.0481	5.31	490.69	0.921	0.938	850.	1.005	2946.39
38	0.4335	250.61	847.7	12.087	0.0482	5.31	491.38	0.921	0.938	850.	1.005	2946.76
39	0.4535	250.61	847.7	12.075	0.0482	5.32	491.65	0.921	0.938	850.	1.005	2946.90
40	0.4745	250.31	845.7	12.057	0.0482	5.31	491.00	0.921	0.938	850.	1.005	2946.56
41	0.4730	250.31	847.7	12.058	0.0482	5.31	491.03	0.921	0.938	850.	1.005	2946.57
42	0.4950	250.31	845.7	12.050	0.0481	5.31	490.72	0.921	0.938	850.	1.005	2946.41
43	0.5135	250.51	845.7	12.057	0.0481	5.31	490.98	0.921	0.938	850.	1.005	2946.55
44	0.5140	250.41	847.7	12.042	0.0481	5.31	491.17	0.921	0.937	849.	1.003	2944.40
45	0.7129	250.01	847.7	12.016	0.0481	5.30	490.18	0.921	0.937	849.	1.003	2943.88
46	0.8134	250.21	847.7	11.989	0.0479	5.30	488.44	0.921	0.938	850.	1.005	2945.22
47	0.9159	250.41	845.7	11.996	0.0479	5.30	489.42	0.921	0.937	849.	1.003	2943.48
48	1.0159	250.31	845.7	12.010	0.0480	5.30	489.95	0.921	0.937	849.	1.003	2943.76
49	1.2663	250.31	847.7	12.051	0.0481	5.31	491.52	0.921	0.937	849.	1.003	2944.58
50	1.5183	250.31	845.7	11.874	0.0474	5.27	486.27	0.921	0.934	847.	1.001	2937.31
51	1.7688	250.21	847.7	11.696	0.0467	5.23	480.26	0.921	0.933	846.	0.999	2931.81
52	2.0193	250.11	845.7	11.718	0.0468	5.24	481.00	0.921	0.933	846.	0.999	2932.21

CALIBRATION CONSTANTS

A00= 9.164E-01 A01= 2.300E-04 A02= 0.000E+00 A03= 0.000E+00 A04= 0.000E+00

MEAN VALUES

PO = 250.82 PSIA U(INF)= 2985.2 FT/SEC
 TO = 846.4 DEGR Q(INF)= 4.144 PSIA
 P(INF)= 0.1672 PSIA T(INF)= 104.7 DEGR
 RE(INF)= 0.474E+07 PER FT POP = 7.70 PSIA
 NU(INF)= 0.843E-07 LBF-SEC/FT² RHO(INF)= 0.136E-03 SLUGS/FT³
 XP = 6324. CTS

ARO, INC - AEDC DIVISION
A OVERDRUP CORPORATION COMPANY
VON KARMAN GAS DYNAMICS FACILITY
ARNOLD AIR FORCE STATION, TENN

DATE COMPUTED 30-JUN-78
DATE RECORDED 14-APR-78
TIME RECORDED 1:35: 1

PROJECT NO Y41B-W6A
SAMSO/DOTR HYPERSONIC TURBULENT BOUNDARY LAYER INVESTIGATION
PHASE II

GROUP 106
N(INF)= 5.95
RE(INF)= 4.744E+06 PER FT

ALPHA MODEL = 0.01 DEG.
ALPHA PD = 0.00 DEG.
ROLL = -89.96 DEG.

DEW PT=-32.00
(DEG F)

CONFIGURATION
7-DEG CONE

NOSE RADIUS, IN
SHARP

TRIP
NONE

DATA TYPE
OVERHEAD PROBE

PROBE STATION = 38.650 IN. STATION NO. = 1

BOUNDARY LAYER VALUES

PRESTON TUBE

DEL = 0.3779 IN.
DEL+ = 0.1650 IN.
DEL2 = 0.0130 IN.
DEL3 = 0.0237 IN.
DEL4 = IN.
H1 = 12.6705
H2 = 0.5403
TED = 851.4 DEGR
VOED= 2944.1 FT PER SECOND
RHOED= 3.118E-04 SLUGS PER FT3

PTAUO= 9.6961E+01
MTAUO= 1.2612E-01
RTAUO= 2.1351E+01
F10 = 1.0811E+03

MEAN VALUES

PO = 250.92 PSIA
TO = 846.4 DEGR
P(INF)= 0.1672 PSIA
RE(INF)= 0.474E+07 PER FT
NU(INF)= 0.843E-07 LBF-SEC/FT2
XP = 6324. CTS
U(INF)= 2985.2 FT/SEC
Q(INF)= 4.144 PSIA
T(INF)= 104.7 DEGR
POP = 7.70 PSIA
RHO(INF)= 0.134E-03 SLUGS/FT3