

AD-A068 559

FOREIGN TECHNOLOGY DIV WRIGHT-PATTERSON AFB OHIO F/G 20/5
INVESTIGATION OF NON-LINEAR PHENOMENA IN SOLUTIONS OF ORGANIC D--ETC(U)
MAR 78 M T SHPAK, Y O TIKHONOV

UNCLASSIFIED

FTD-ID(RS)T-0258-78

NL

| OF |
AD
A068559



END
DATE
FILMED
6-79
DDC

AD A068559

FTD-ID(RS)T-0258-78

1

FOREIGN TECHNOLOGY DIVISION



INVESTIGATION OF NON-LINEAR PHENOMENA IN SOLUTIONS OF ORGANIC DYES AND THE CREATION OF HIGH-EFFICIENCY LASERS WITH FREQUENCY TUNING BASED ON THEM

by

M. T. Shpak, Ye. O. Tikhonov

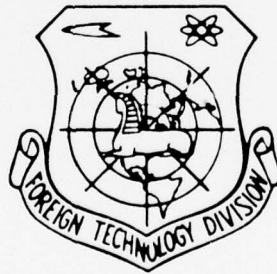

DDC
REFINED
MAY 14 1979
RECEIVED
D

Approved for public release;
distribution unlimited.

78 12 22 197

White Section	<input checked="" type="checkbox"/>
Buff Section	<input type="checkbox"/>
UNANNOUNCED	<input type="checkbox"/>
IDENTIFICATION	
INVESTIGATION/AVAILABILITY CODES	
AVAIL. and/or SPECIAL	
A	

EDITED TRANSLATION

FTD-ID(RS)T-0258-78

21 March 1978

MICROFICHE NR: *FD-78-C-000391L*

INVESTIGATION OF NON-LINEAR PHENOMENA IN SOLUTIONS OF ORGANIC DYES AND THE CREATION OF HIGH-EFFICIENCY LASERS WITH FREQUENCY TUNING BASED ON THEM

By: M. T. Shpak, Ye. O. Tikhonov

English pages: 17

Source: Visnyk Akademiya Nauk Ukrayskoy RSR, No. 11, 1971, pp. 9-18.

Country of origin: USSR

Translated by: LINGUISTIC SYSTEMS, INC.
F33657-76-D-0389
R. Van Emburgh

Requester: FTD/TQTD

Approved for public release; distribution unlimited.

THIS TRANSLATION IS A RENDITION OF THE ORIGINAL FOREIGN TEXT WITHOUT ANY ANALYTICAL OR EDITORIAL COMMENT. STATEMENTS OR THEORIES ADVOCATED OR IMPLIED ARE THOSE OF THE SOURCE AND DO NOT NECESSARILY REFLECT THE POSITION OR OPINION OF THE FOREIGN TECHNOLOGY DIVISION.

PREPARED BY:

TRANSLATION DIVISION
FOREIGN TECHNOLOGY DIVISION
WP-AFB, OHIO.

[Ukrainian]

INVESTIGATION OF NON-LINEAR PHENOMENA IN SOLUTIONS OF
ORGANIC DYES AND THE CREATION OF HIGH-EFFICIENCY LASERS
WITH FREQUENCY TUNING BASED ON THEM

by

M. T. Shpak, Corresponding Member of the Academy
of Sciences of the Ukrainian SSR,
Ye. O. Tikhonov, Candidate of Physical-
Mathematical Sciences

Lasers, which were developed about ten years ago, are now widely used in various branches of science, engineering and everyday human activity. There is a whole series of scientific and applied problems, e.g., nonlinear optics and holography, that could not be worked out (generally speaking) without the use of lasers.

In solving various scientific and practical problems, a need often arises to change the frequency of laser radiation. In the wavelength interval from 0.2 to 1.2 microns ^{continuous} ~~direct~~ setting of frequencies for laser radiation can be achieved quite easily by using solutions of complex organic compounds, especially dyes of different types, as the active medium.

A.P. Ivanov (Institute of Physics of the Academy of Sciences of the Byelorussian SSR) first noted the possibility of light amplification by complex organic molecules as early as 1960, i.e., before the appearance of the first lasers [1]. Two years later the Kievite physicists V.L. Broude, V.S. Mashkevich and A.F. Prikhot'ko proposed the use of molecular crystals of organic compounds as the active medium [2].

In the early 1960's several theoretical papers dealing with the use of singlet-singlet transfers of complex molecules were published. Dealt with as well were similar systems based on transi-

tion metals in crystalline matrices for obtaining stimulated emission [3,4,5,6].

A group of Byelorussian physicists under the direction of B.I. Stepanov [7] conducted a more detailed theoretical investigation of the processes of induced fluorescence in solutions of complex organic molecules between 1964 and 1966.

In 1966 the American physicists P.P. Sorokin and G.R. Lankard first obtained generation in a solution of chloraluminum phthalocyanin_λ^e in ethyl alcohol, using giant pulses of nanosecond duration generated by a ruby laser for optical excitation [8].

In our country, the first papers describing active dye lasers appeared in 1967 [9,10].

We shall examine the principal characteristics of lasers in which molecular solutions of organic dyes are used as the active medium.

In a system of luminescence centers with narrow energy levels, an inverse population only arises in those situations where no less than three levels take part in the induced process. In the given case of a two level system, ^{using} ~~generation~~ _{quasi-continuous} is only possible when the energy levels are broadened and are ^{electron-vibration} bands.

Fig. 1 depicts a phenomenological diagram of the levels in a complex molecule.

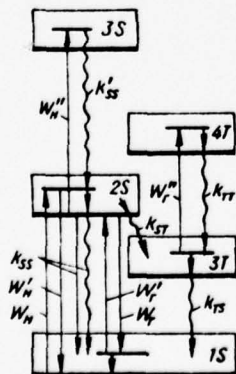

Fig. 1. Phenomenological diagram of electron-vibration states in a complex organic molecule: S - singlet state, T - triplet state, W_3 - probability of absorption, k_{SS} , k_{TS} - rate of emitting and non-emitting deactivation of the singlet and triplet states, respectively, W_R - probability of induced radiation, k_{ST} - rate of intercombination.

In the case of balanced distribution of particles in the vibration sublevels of the singlet electron-vibration states 1 and 2 (Fig. 1), the amplification factor at frequency ν , which corresponds to the induced transfers between these states, in the simplest case has the form:

$$k_{21}(\nu) = N\sigma_{21}(\nu) \left[\frac{N_2}{N} - \frac{N_1}{N} \exp\left(-\frac{\nu_{e1} - \nu}{kT}\right) \right], \quad (1)$$

where N_1 , N_2 are the populations of the upper and lower active levels, $N = N_1 + N_2$ is the number of luminescence centers per unit volume, ν_{e1} is the frequency of purely electron transfer, kT is the product of the Boltzmann constant for absolute temperature. It follows from (1) that the following inequality is the condition for the appearance of amplification:

$$\frac{N_2}{N} > \exp\left[-\left(\frac{\nu_{e1} - \nu}{kT}\right)\right]. \quad (2)$$

Analysis of this inequality shows that for frequencies $\nu > \nu_{e1}$, it is satisfied only with an inverse population of states 1 and 2; for frequencies $\nu < \nu_{e1}$, amplification will also arise when $N_2 < N_1$, since the larger the interval $\nu_{e1} - \nu$, the lower the value N_2/N_1 will be at which amplification will occur. The transfer of molecules to the triplet state and the absorption of light by triplet and excited singlet states $S_2 \rightarrow S_3$, $T_3 \rightarrow T_4$ also has a significant effect on the amount of amplification (see Fig. 1).

The second important generation parameter - the threshold intensity of excitation I_{thr} - can be determined from the relationship:

$$\frac{N_2}{N_1} = \frac{a}{1 + a^2 \frac{8\pi\nu\Delta\nu}{\nu^2\tau_{1sup}I_{thr}}} \geq \exp\left[-\left(\frac{\nu_{e1} - \nu}{kT}\right)\right], \quad (3)$$

where $a = \exp\left[-\left(\frac{\nu_{e1} - \nu_3}{kT}\right)\right]$, ν_3 is the frequency of excitation, $\Delta\nu$ is the half-width of the fluorescence [emission] band, ν is the rate of

diffusion of light in the solution, η is the quantum efficiency.

From Eq. (3) it is apparent that the threshold intensity of excitation is proportional to the half-width of the fluorescence band of the solution and inversely proportional to the quantum efficiency and the value of the Stokes' shift for the maxima of the absorption and emission bands.

Eq. (3) is only correct in cases of small optical densities $d = 0.434N\sigma_{12}(\nu)\ell < 1$, where ℓ is the length of the active medium.

In practice, optically dense solutions ($d = 4-6$) are used, and for this reason the generation threshold of solutions of organic dyes depends on the concentration of molecules in the solution. The relationship between the lifetime of the excited state, the time for two-way wave transfer in the resonator, the duration of the optical excitation pulse, as well as the geometry of the system for optical excitation of the active medium have a significant influence on the generation threshold.

Thus, the coefficient of transformation of excitation energy into energy of induced radiation for a dye solution is higher, the greater the quantum efficiency of fluorescence, the less the overlapping of the absorption and fluorescence bands, the ^{greater} ~~higher~~ the ^{uniformity} ~~homogeneity~~ of the excited amount of dye, and the shorter the laser's resonator are.

The width of the spectra of generation in dye solutions reaches $100-200 \text{ cm}^{-1}$ as a result of various unstable processes, but owing to the ^{uniform} ~~homogeneous~~ broadening of the band, amplification can be effectively reduced if some type of narrow-band optical filter is inserted into the resonator (interferometer, diffraction grating, prism, etc.).

Investigations into laser physics involving solutions of organic dyes were begun at the Institute of Physics of the Academy of

Sciences of the Ukrainian SSR in 1966. They were based on studies of passive modulators of high ^{Q-factor} quality in solutions of dyes.

The principal aim of the investigations was to create a unified picture of the processes that occur in solutions of complex organic molecules under the influence of an intensive stream of coherent, monochromatic light, and to develop, as the end result, new, highly efficient active media, needed for lasers with frequency tuning.

The work was performed jointly with the Institute of Organic Chemistry of the Academy of Sciences of the Ukrainian SSR, which provided various types of cyanine dyes, including some unique ones, for the experiments. Fig. 2 shows the structural formula and dependence of the absorption band maximum on the number of conjugated bonds for one of the dye types, which is characterized by considerable quantum efficiency.

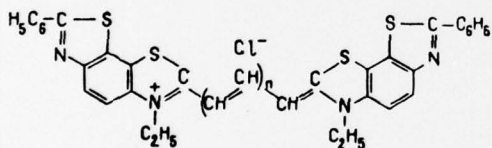

Fig. 2. Homologous series of a cyanine dye suitable for ^{lasing} generation in the 7100-10000 Å region. When $n = 1$, $\lambda_p = 600$ nm; $n = 2$, $\lambda_p = 694$ nm; $n = 3$, $\lambda_p = 800$ nm; $n = 4$, $\lambda_p = 900$ nm; $n = 5$, $\lambda_p = 1000$ nm.

Among the cyanine dyes, there are samples that are distinguished by stability against photochemical transformations and by a rather high quantum efficiency of luminescence when the Stokes' shift is quite large. Our studies revealed that of the currently available dyes that generate following excitation by single pulses from a ruby laser in the near infrared region, the cyanine dyes meet the requirements of an optimum active medium most fully.

The principal results of our investigations were set forth in [10-18].

As a result of studies with Q-factor self-modulation (passive modulation), a new, efficient system for Q-factor modulation of ruby lasers was proposed, which operates in the condition of phased and random modes (Fig. 3a, b).

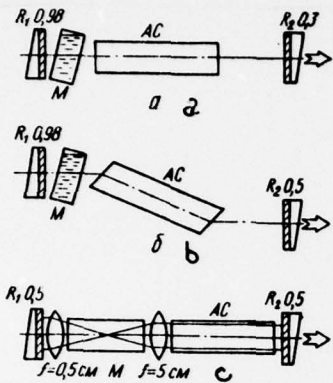

Fig. 3. Optical diagram of a solid-state laser with generation: a - of nanosecond giant pulses; b - of picosecond giant pulses; c - diagram with Q-factor modulation, which is based on the phenomenon of Brillouin scattering of light.

Phasing of laser modes results in the generation of picosecond pulses with a peak power at a hundred megawatts. Self-phasing of modes in lasers can only be achieved based on the rapidly relaxing solutions of dyes, whose brightening effect is caused by the population of the first excited singlet state. As a rule, this condition is met by the majority of ethanol solutions of cyanine dyes that are in equilibrium with the oxygen in the air.

We are now engaged in studies using picosecond pulses to detect phenomena associated with disturbances of equilibrium in ~~generating~~^{lasing} systems.

Another method of Q-factor modulation proposed by us is based on the phenomenon of induced Brillouin scattering (scattering of light at hypersonic vibrations of the medium's density). Fig. 3c depicts a diagram of a solid-state laser with Q-factor modulation using this method. Liquids with a relatively low threshold of induced Brillouin scattering (CS_2 , H_2O , etc.) were used here as the modulating system.

Normal scattering at hypersonic vibrations, excited as a result of electrostriction, leads to a shift in the generation line by about

0.2 cm⁻¹ for each two-way passage of light in the resonator. After a small shift even during repeated scattering, the generated frequency remains within the contour of amplification of the active medium (ruby, neodymium glass). Excitation of induced scattering, which is characterized by asymmetry in the normal direction up to 90-95%, is equivalent to instantaneous increase in the Q-factor of the resonator. In the proposed method, modulation of the Q-factor does not depend on the frequency of generation, and the modulator itself does not undergo photochemical decomposition.

The compounds studied in solution had a single photon singlet-singlet transfer permitted in absorption, distributed in the region of the ruby laser's radiation frequency, but essentially different from one another by an entire series of different spectral and energy parameters.

Experimental and theoretical investigations of nonlinear absorption of nanosecond light pulses from a ruby laser by solutions of organic dyes and radicals of several chemical types led to the establishment of a series of important regularities. The compounds in solution that we studied permitted a single-photon singlet-singlet transfer in absorption, distributed in the region of the ruby laser's radiation frequency, but they were distinguished from each other by a whole series of different spectral and energy parameters.

With a time of adiabatic relaxation of complex molecules in solution on the order of 10⁻¹² - 10⁻¹³ sec and with nanosecond excitation durations, nonlinear absorption is non-coherent.

Measurement of the coefficients of nonlinear absorption of solutions at the frequency of radiation from a ruby laser ν as a function of incident intensity has led to the establishment of the following characteristic relationships:

- a) $\frac{dk(\nu)}{dI(\nu)} < 0$ (Fig. 4, curves 2,5,6,7),
 b) $\frac{dk(\nu)}{dI(\nu)} > 0$ (Fig. 4, curves 4,9),
 c) $\frac{dk(\nu)}{dI(\nu)} = 0$ (Fig. 4, curve 8),
 d) $\frac{dk(\nu)}{dI(\nu)} < 0$ (Fig. 4, curves 1,3).
- (4)

Relationship 4a denotes optical brightening and is characteristic for media that do not have singlet-singlet absorption at a frequency

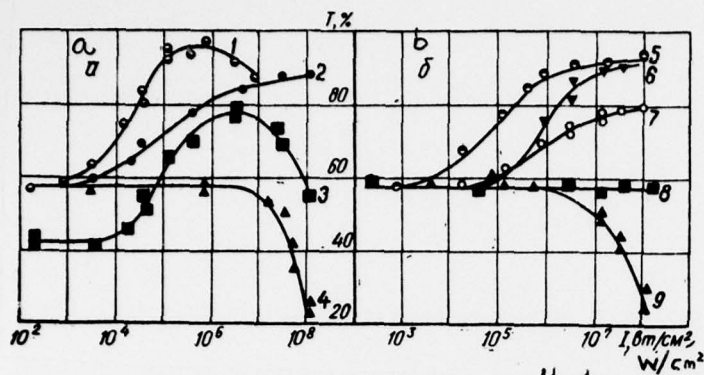

Fig. 4. Curves of nonlinear absorption of dyes at the excitation frequency.

of 2ν . For solutions of dyes ^{that} with allowed transfers at the doubled frequency of excitation, optical darkening (case 4b) or optical neutrality (case 4c) in the wide interval of changes in the intensity of excited light are observed.

Quantitative analysis of the experimentally observed relationships was performed within the framework of a method of balancing equations for ^{the uniformly} ~~homogeneously~~ broadened electron vibration states, typical for complex organic molecules.

Comparison of the analytical expressions for $k(\nu) = f(I)$ with the corresponding experimental curves (Fig. 4) enabled us to determine a series of spectroscopic parameters of the molecules of dyes in solutions. Thus, for case 3a, the relationship k_{ST}/k_{TS} is determined (k_{ST} and k_{TS} correspond to the rate of singlet-triplet conversion and decomposition of the triplet state); for solutions of dyes with a small value of k_{ST} , when transfers in the system of triplet states can be ignored, a cross section of transfers from the excited singlet states is determined (see Fig. 1).

Solutions of dyes that have the properties (a,b,c,d) can be used for various practical purposes, viz., 1) for passive Q-factor modulation of lasers, 2) for the development of instruments that provide protection from powerful light radiation, 3) for the development of neutral (with respect to powerful light radiation) filters, 4) for power stabilization of laser radiation.

An entire series of experiments was conducted in order to study the conditions for obtaining high coefficients ^{of} radiation transfor-

mation for the excitation energy in the generated radiation.

Within the above-mentioned method of balancing equations, the expected values for the amplification factors in singlet-singlet and triplet-singlet transfers, characteristic for molecules of organic dyes, were analyzed.

Under conditions of stable excitation, the ratio of populations of excited singlet and triplet states equals the value k_{TS}/k_{ST} , and is almost always less than one. However, owing to the difference by several orders of magnitude of oscillators of the singlet-singlet and triplet-singlet transfers in complex organic molecules, this circumstance cannot be used to amplify generation in the triplet-singlet transfer.

During unstable excitation, the ratio of populations of singlet and triplet states can be considerably larger than one, and the conditions for amplification and generation become favorable for singlet-singlet transfers even when the value of k_{ST}/k_{TS} is large. For solutions of dyes with a small value of k_T/k_{TS} , amplification and generation can also be achieved with stable populations.

An experimental check of some of these conclusions was carried out on a group of solutions of organic dyes, excited by successive pulses from a ruby laser, operating in the free generation mode. A comparison of the bending ^[deformation] sequence of the solution's generation pulses and the bending [sequence] of the excitation pulses confirms the conclusion regarding the presence of an amplification maximum during the transfer process.

Investigations of the generation mode of radiation have shown that ^{the} spectral position of the average frequency of generation is a function of the optical density of the active medium (the number of centers in the ^{lasing} ~~generating~~ ^{substance} ~~volume~~) and the amount of neutral [non-selective] losses. This phenomenon is caused by the frequency depen-

dence of the amplification curve maximum on the relative population of functional states and can be used for smooth changes in the laser's frequency (with insignificant population of the singlet excited state, the amplification maximum is situated in the long wavelength tail of the fluorescence band; with complete inversion, it coincides with the maximum of the fluorescence band). The shift in the amplification band maximum as a function of the spectral position of the excitation line within the absorption band exhibits the same characteristics.

Nonlinear absorption of the active medium exerts considerable influence on the operation of dye lasers excited by intense sources of directed radiation. Calculation shows that there is an optimum value for the optical density of an active medium, which equals:

$$d_{opt}(\nu_3) = \alpha(\nu_3) I(\nu_3) = \left\{ 1 + \frac{k_{ST}}{k_{TS}} + \exp \left[- \left(\frac{\nu_{st} - \nu}{kT} \right) \right] \right\} \eta_{\sigma_{12}}(\nu_3) \tau_0 I(\nu_3), \quad (4)$$

where $\alpha(\nu_3)$ is the nonlinearity at the excitation frequency for a dye with a real intermediate triplet level, $I(\nu_3)$ is the threshold intensity of excitation, τ_0 is the radiation lifetime of the singlet state.

The experimental value $d_{opt}(\nu_3)$ for the majority of cyanine dyes lies between 4 and 6, if the Stokes' shift for the excitation frequency does not greatly exceed 1000 cm^{-1} . Using relationship (4) and the experimental dependence on the optical density of the active medium, it is possible to determine independently the nonlinearity of the active medium.

To develop high-efficiency dye lasers, the optimum parameters of the active medium, excitation and the resonators were found.

It has been shown experimentally that the energy efficiency of ^{lasing} generation for dye solutions increases the most with an increase

in the quantum efficiency from 1 to 50% and that it depends on the length of the resonator to a large degree. The latter is associated with the fact that, for pulse lasers, the losses associated with ^{the} total time for formation of a stable field in the resonator and the lifetime of the excited singlet state of dye molecules ^{and} with the duration of the excitation pulse, are significant.

Optimization of the optical arrangement for excitation will result in the achievement of a ~~homogeneously~~ ^{uniformly} excited volume of active medium. Owing to the non-uniformity in intensity distribution of beams from a solid-state laser, the greatest uniformity of excitation in a dye solution is attained along the direction ^{of} broadening of excitation. At angles greater than 5° between the direction of the excitation and ~~generation~~ ^{lasing} beams, losses increase rapidly and the energy efficiency of generation diminishes.

Thorough investigation of a number of arrangements for optical excitation and resonator configurations has led to the development of systems that enable us to attain coefficients of transformation on the order of 50-60% with an output power on the order of 10-20 MW (Fig. 5). It was demonstrated, in particular, that the so-called transverse method of excitation of organic dye lasers, which is often used in practice, is of low efficiency.

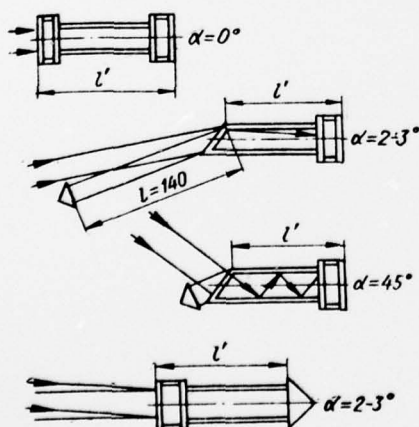

Fig. 5. Optical diagram of resonator configurations for organic dye lasers. In diagrams 1 and 4, an efficiency of 50-60% is achieved; in diagrams 2 and 3, the efficiency is less than 20% owing to the increased length of the resonator base (diagram 2) and the reduced uniformity in excitation of the active medium (diagram 3). Numbering of the diagrams is from top to bottom.

The results shown have become the basis for development of the high-efficiency "Infra" series of organic dye lasers with a tuned

lasing
 generation frequency.

Lasers of this system are excited by commercially produced ruby lasers with Q-factor modulation without mode phasing and they ensure a continuous spectrum of generated frequencies in the 7100-10000 Å region with a radiation bandwidth close to 1 Å and a beam deviation on the order of 3-5 mrad, that is, the same as that of the ruby laser.

During the interaction of laser radiation with solutions of organic dyes, a number of interesting physical phenomena are observed, which we detected first.

In active media based on solutions of organic dyes with high quantum efficiency, pulse amplification exceeding tens of cm^{-1} is easy to achieve. In this case, induced radiation of a continuous mode spectrum is possible - superluminescence.

Superluminescence develops as a result of amplification of the ordinary luminescence of an active medium in a system without a reverse connection (lack of mirrors) for calculating the induced radiation. In contrast to generation, superluminescence is characterized by a continuous spectrum of modes and by exponential dependence of the increase in intensity (Fig. 6). A study of superluminescence permits us to observe the development of the radiation spectrum during a change in intensity of the excited light, and the nature of the changes in the radiation contour during superluminescence enables us to reach some conclusions regarding the high degree of spectral uniformity in the amplification band of dye solutions.

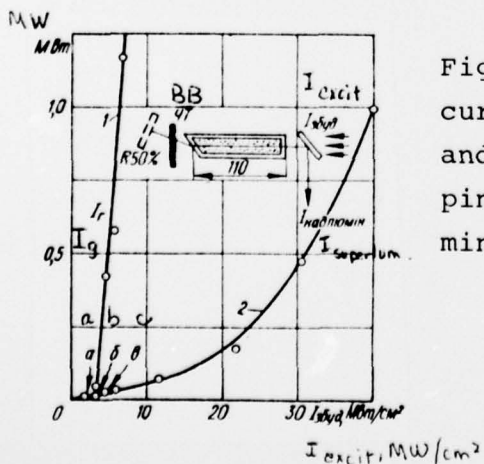

Fig. 6. Diagram of the experiment and curve of superluminescence intensity (1), and generation intensity (2) versus pumping intensity. BB - black body for eliminating the reverse connection.

The use of intense, monochromatic radiation for excitation of solutions of organic dyes results in amplification of the lines of Raman scattering in the solution, which are found in the amplification or generation band of the dye. In the first situation that was mentioned, generation of radiation in a complex system having a common resonator, via a connection along the electromagnetic field, occurs at the frequency of maximum amplification for the entire system:

$$\frac{d}{d\nu} [k_1(\nu) + k_2(\nu)] = 0, \quad (5)$$

where $k_1(\nu)$ is the amplification coefficient for the excited dye molecules and $k_2(\nu)$ is the amplification coefficient for the process of induced Raman scattering.

In the second situation, an increase in the probability of scattering occurs according to the expression:

$$W_{kn} = A_{kn} I(\nu) + \sigma_{kn} I(\nu) I(\nu - \nu_k), \quad (6)$$

where A_{kn} , σ_{kn} are the coefficients for the processes of spontaneous and induced scattering, n, k are the subscripts of the initial and final vibration states of a single electron level, $I(\nu - \nu_k), I(\nu)$ are the intensity of radiation at the Raman scattering frequency and the intensity of excitation.

Analogous principles of amplification were established on the basis of experimental investigations of the lines of the resonance Raman effect induced by molecules of dye.

When the band of induced fluorescence and the resonance Raman effect lines coincided, we succeeded in observing the latter in the induced process.

Under the conditions of the experiments conducted to observe induced resonance Raman scattering, it is possible to compare the

the populations of the fundamental and excited singlet and triplet states, and as a result of this, to obtain, in principle, the Raman scattering line that characterizes a vibration spectrum in the excited state. We are now engaged in work along these lines. The described principle of amplification can be used for detecting relatively weak lines of induced Raman scattering and for developing narrow-band (generation bandwidth on the order of 1 cm^{-1}), high-efficiency lasers.

We first detected and studied induced resonance Rayleigh scattering of light by solutions of organic dyes. As the experiment shows, the spectrum of light scattering is composed of a band that, in terms of polarization and frequency (to within about 0.02 cm^{-1}), coincides with the excitation band and thus can be identified with the central component of the Rayleigh triplet. Based on experimental data we concluded that the integral intensity of scattering is governed by two processes: thermal Rayleigh scattering and Rayleigh scattering in degenerate vibration sublevels of the fundamental state. It is expected that thermal Rayleigh scattering is caused by the structure created by the dye molecule and by its solvate film of solvent molecules. The dielectric permeability of this structure differs from the average dielectric permeability of the medium by the value $\Delta E = (\partial E / \partial T)_\rho \Delta T$, until thermal equilibrium with the surrounding medium is reached.

The main results of the experiments conducted can be briefly set forth thus.

The mechanism of amplification and generation of light by solutions of complex organic molecules was studied theoretically and experimentally, and the optimum conditions for the development of a generating process in the singlet-singlet electron vibration transfers of these molecules was found; first, a series of induced resonance nonlinear effects in solutions of organic dyes was detected and studied: superluminescence, resonance induced Rayleigh and Raman

scattering, the effect of a solvent with intense Raman scattering bands on ^{both} the process and the generation spectrum. High-efficiency organic dyes were found and studied that enable us to achieve generation with continuous tuning of the frequency in the visible and near infrared region of wavelengths when the composition of the active molecules, ^{and} their concentration in the solutions is changed, and by using selective elements in the resonator.

We recently investigated the possibility of using complex organic compounds in the crystalline phase for generating [lasing] the second harmonic of ruby and neodymium lasers.

Measurement of the second harmonic of a neodymium laser, which is based on crystalline powders of dyes from the majority of existing chemical classes, has shown that an intensive harmonic is generated by the triphenylmethanes, diphenylmethane anthraquinones, and some of the cyanine dyes. The efficiency of generation of the second harmonic for the better samples is either comparable to or exceeds the efficiency of generation by lithium niobate powder (see table).

[TABLE]

Compound	Relative intensity of 2nd harmonic referred to LiNbO ₃ powder	Compound	Rel. intensity of 2nd harmonic referred to LiNbO ₃ powder
3,4-AS-benzanthracene*	~0.05	2-(p-dimethylaminostyrol)	
benzophenone	0.1	quinoline	0.5
x Anthone	0.1	benzoylquinaldine	0.2
1-methoxyanthraquinone	0.1	urotropine	0.1
1-dihydroxyanthraquinone**	0.5	m-nitrobenzaldehyde	0.5
benzanthrone	0.4	resorcinol	0.2
3-methoxybenzanthrone	0.1	methyl green	0.1
3-bromobenzanthrone	1.0	malachite green	0.5
3-nitrocarbazole	~0.05	brilliant green	0.5
nitrostyrolquinoline	0.5	quinidine sulfate	~0.05
		cane sugar	~0.05

*) Translator's note : meaning of "AS" unknown ;
 **) " " : uncertain

Owing to the practical solution of the problem of growing large, perfect monocrystals of complex organic compounds, researchers are obtaining a large group of new materials with easily detectable nonlinear optical properties.

Investigations involving the physics of lasers in solutions of complex organic molecules are now being intensively conducted in many countries.

It is possible to predict that organic dye lasers will be widely used in various branches of the national economy in the near future.

Lasers with tuned frequency, above all, are high-aperture spectral instruments that enable us to investigate ultraviolet and infrared spectra in the visible region of wavelengths with the help of nonlinear systems. These lasers can also be used to study the properties of substances with large concentrations of excited states in them, for studying the nature and dynamics of chemical reactions, and for selective destruction of genes which is important for future problems in "controlled genetics".

Lasers can be used to measure the altitude and composition of clouds, to detect smoke, fog, turbulent streams in the air, for space communication in "transparent windows" of the atmosphere.

Range finders in organic lasers can be equipped with receivers that are 1-2 orders of magnitude more sensitive than those that are now in use in neodymium and ruby lasers.

The absorptive capacity of tissues in a living organism depends on the frequency of the incident light, and for this reason lasers with tuned frequency can be used to effectively cut various tumors without damaging the area surrounding them, i.e., for laser surgery.

These are only some of the possible applications of lasers with

tuned frequency in solutions of organic dyes, which are already a reality.

LITERATURE

- [1] Ivanov, A.P., Opt. Spektroskop. 8, 352 (1960).
- [2] Broude, V.P., Mashkevich, V.S., Prikhod'ko, A.F., Prokopyukh, N.F., and Soskin, M.S., Fiz. Tverd. Tela 4, 2976 (1962).
- [3] Rautian, S.G., and Sobel'man, I.I., Opt. Spektroskop. 10, 134 (1961)
- [4] Brock, E.G., Csavinszky, P., Hormats, E., Nedderman, H.C., Stikpe, D., and Unterleitner, F.J., J. Chem. Phys. 35, 759 (1961).
- [5] McCumber, D.E., Phys. Rev 134, A299 (1964).
- [6] Ratner, A.M., Zh. Experiment. Teoret. Fiz. 34, 115, (1964).
- [7] "Methods of Laser Calculation" [Metody rascheta OKG], volume 1, B.I. Stepanov, ed., Publishing House "Nauka i Tekhnika," Minsk, 1966.
- [8] Sorokin, P.P., Lankard, J.P., IBM J. Res. Dev. 10, 162 (1966).
- [9] Stepanov, B.I., Rubinov, A.N., and Mostovnikov, V.A., Zh. Exper. Teoret. Fiz., letter to the editor, 5, 144 (1967).
- [10] Tikhonov, E.A., Shpak, M.T., Ukr. Fiz. Zh. 12, 2077 (1967).
- [11] Dyadyusha, G.G., Tikhonov, E.A., Shpak, M.T., Ibid., 1529 (1968).
- [12] Tikhonov, E.A., Shpak, M.T., Zh. Prik. Spektr. 9, 784 (1968).
- [13] Tikhonov, E.A., Shpak, M.T., Ukr. Fiz. Zh. 13, 1378 (1969).
- [14] Tikhonov, E.A., Shpak, M.T., Ibid., 15, 344 (1970).
- [15] Tikhonov, E.A., Shpak, M.T., Ibid., 5, 567 (1966).
- [16] Aslanidi, E.B., Gandel'man, I.L., Tikhonov, E.A., Shpak, M.T., Ibid., 15, 1284 (1970).
- [17] Melishchuk, M.V., Tikhonov, E.A., Shpak, M.T., Ibid., 16, 451 (1971).
- [18] Tikhonov, E.A., Shpak, M.T., Zh. Exper. Teoret. Fiz., letter to the editor, 8, 282 (1968).

DISTRIBUTION LIST

DISTRIBUTION DIRECT TO RECIPIENT

ORGANIZATION	MICROFICHE	ORGANIZATION	MICROFICHE
A205 DMATC	1	E053 AF/INAKA	1
A210 DMAAC	2	E017 AF/RDXTR-W	1
B344 DIA/RDS-3C	8	E404 AEDC	1
C043 USAMIIA	1	E408 AFWL	1
C509 BALLISTIC RES LABS	1	E410 ADTC	1
C510 AIR MOBILITY R&D	1	E413 ESD	2
LAB/FIO		FTD	
C513 PICATINNY ARSENAL	1	CCN	1
C535 AVIATION SYS COMD	1	TQIS	3
		NIA/PHS	1
C591 FSTC	5	NICD	2
C619 MIA REDSTONE	1		
D008 NISC	1		
H300 USAICE (USAREUR)	1		
P005 ERDA	1		
P055 CIA/CRS/ADD/SD	1		
NAVORDSTA (50L)	1		
NASA/KSI	1		
AFIT/LD	1		