

Datacomputer and SIP Operations: 1978 Final Technical Report

AD A 0 6 8 6 0 8

LEVEL II

P.S.
12

DDC
RECEIVED
MAY 15 1979
[Signature]

Technical Report
CCA-79-11
February 26, 1979

Donald E. Eastlake, III
Matthew Maltzman
Joanne Z. Sattley

DDC FILE COPY

This document is being prepared
for public release and under its
distribution is unlimited.

79 05 21 001

Computer Corporation of America
575 Technology Square
Cambridge, Massachusetts 02139

12

6

Datacomputer and SIP
Operations

9

1978 Final Technical
Report for period ending 1978

DDC
MAY 15 1979
RECEIVED

Technical Report
14 CCA-79-11

10

Donald E. Eastlake, III
Matthew Maltzman
Joanne Z. Sattley

11

30 March 1979

12 82p.

This research was supported by the Advanced Research
Projects Agency of the Department of Defense under
Contract No. 5 N00039-78-C-0246, ARPA Order 3540.
The views and conclusions contained in this document
are those of the authors and should not be interpreted
as necessarily representing the official policies,
either expressed or implied, of the Advanced Research
Projects Agency or the U.S. Government.

387285

JB

List of Figures

Figure 2.1 Seismic Data Network	7
Figure 2.2 Geographic Representation of VELA Network	9
Figure 2.3 Seismic Data Accumulated	11
Figure 2.4 Non-Seismic Data Accumulated	14
Figure 2.5 Datacomputer Availability by Month	17
Figure 3.1 MARS: Cumulative Summary of Messages Filed	26
Figure 4.1 SWF Data Flow	38
Figure 4.2 SWF-D Data Flow	39
Figure 5.1 SIP Data Flow	45
Figure 5.2 SIP Hardware Structure	47
Figure 6.1 CCA TBM Hardware Structure	52
Figure 6.2 TBM Configurations	55
Figure 7.1 CCA TENEX Hardware	58
Figure A.1 Datacomputer's User View	65
Figure A.2 Software View of the Datacomputer	69
Figure B.1 Datacomputer 1971-75	72
Figure B.2 Datacomputer 1976-80	73

List of Tables

Table 2.1 Seismic Datacomputer Users	6
Table 2.2 Some Non-Seismic Datacomputer Users	12
Table 2.3 Datacomputer Availability Statistics	18
Table 6.1 TBM Availability Statistics	54

1. Summary

↓
During 1978, Computer Corporation of America offered very large on-line data storage and retrieval services on the Datacomputer in support of the seismic community data activities and for general use. The volume of data stored, the number of users, and the diversity of user projects was substantial at the start of the year and continued to grow throughout the reporting period.

→ The Datacomputer is a system designed to allow convenient and timely access to large on-line databases for multiple remote users communicating over a network. The Datacomputer is the only operational general purpose database system capable of handling data sets in excess of a trillion bits.

Copious and inexpensive storage is a unique feature of the CCA Datacomputer, made possible by the incorporation of an Ampex Tera-Bit Memory System (TBM). The TBM at CCA was the first public installation of this video-tape technology based system. The CCA installation is configured to hold up to 175 billion bits on-line with four TBM tape drives. Additional data (almost entirely seismic) is stored in off-line TBM tapes.

Appendix A to this report gives an overview of the Datacomputer itself; Appendix B is an historical account of the development of the Datacomputer.

In addition to operating the Datacomputer, CCA also provides help and consultation to both its seismic and general user community. This assistance frequently takes the form of technical advice which is aimed at achieving the maximum benefit from the unique capabilities offered by the Datacomputer. As another form of assistance, CCA has implemented and continues to maintain several programs and subroutines which run on remote Arpanet user hosts; these provide users across the Arpanet with convenient interfaces to the Datacomputer. DFTP and DCSTAT are prominent examples of such popular utility programs.

The development of a novel Message Archiving and Retrieval Service (MARS) has provided yet another use for the large storage capacity and lookup capabilities of the Datacomputer. MARS users do not communicate directly with the Datacomputer, but rather, use ordinary network mail channels to transmit messages for filing and retrieving; program demons operate on CCA-Tenex to perform and manage the Datacomputer interactions.

Particular effort was directed in 1978 toward assisting in the design for the Signal Waveform File project, and

toward implementation by CCA of a part of this new seismic application for the Datacomputer.

The seismic application is the largest user of the Datacomputer. This is true not only in terms of the amount of data stored, but also in terms of its complexity, and the bandwidth of transfer. Some of the data involved is sent in real time to CCA, but not directly to the Datacomputer. The real-time data stream is fielded by a small reliable dedicated processor, called the Seismic Input Processor, or SIP. This sturdy interface was designed and implemented by CCA; the SIP reformats received data for efficiency, and periodically forwards it in quantity to the Datacomputer.

Maintenance of the Datacomputer itself is continuing on a regular basis in conjunction with a modest amount of work on desirable software improvements. Some of the developmental work is being funded under a separate contract (N00039-77-C-0074) -- but its fruits are made available to all Datacomputer users. 1978 also saw the issuance of an all-new complete Datacomputer user manual and other user-oriented documentation.

The CCA Datacomputer runs under a TENEX operating system which has been extensively modified to accommodate it. During 1978, some additional modifications to the system

and to one of its utility programs were made in order to facilitate the continuing increase in the size of the Datacomputer directory and to enable faster response to occasional equipment malfunctions. Other general support software upgrades were also made. Some problems were encountered with the CCA-TENEX Arpanet interface due to work on other hosts connected through our on-site PLURIBUS IMP and the fact that this IMP, though a multi-processor, has only one bus.

Overall, the Datacomputer and SIP continue to provide unique very large database management services to seismic and other users over the Arpanet.

2. Support of the User Community

One of CCA's most important tasks under this contract is to provide assistance and coordination for the seismic community and for other users of the Datacomputer. Such assistance and coordination are not only beneficial but necessary to users so that they can get the most out of the Datacomputer as a network utility resource.

Below we give overviews of the seismic and general user communities, details on the Datacomputer operations and usage trends in 1978, and descriptions of significant developments in the CCA-provided Datacomputer user interface DCLINK subroutine package, DFTP program, and MARS service.

2.1 The Seismic User Community

The seismic users of the Datacomputer (see Table 2.1) are primarily concerned with research in the seismic nuclear

Seismic Datacomputer Users

Table 2.1

Albuquerque Seismological Laboratory

Lincoln Laboratory
Applied Seismology Group

National Earthquake Information Service

Seismic Data Analysis Center
Teledyne Geotech
Texas Instruments

Vela Seismological Center

monitoring area. Their principal source of data is the worldwide network of seismic instruments, transmission lines, and data processors known as the Vela Network. Some components of the Velanet are on the Arpanet and use it as a transmission system, while other parts use leased lines for real time data or the shipment of magnetic tape for non-real time data. Figure 2.1 shows the Vela Network configuration superimposed on a map on the Arpanet. Figure 2.2 (provided by the Seismic Data Analysis Center (SDAC))

Figure 2.1

Seismic Data Network

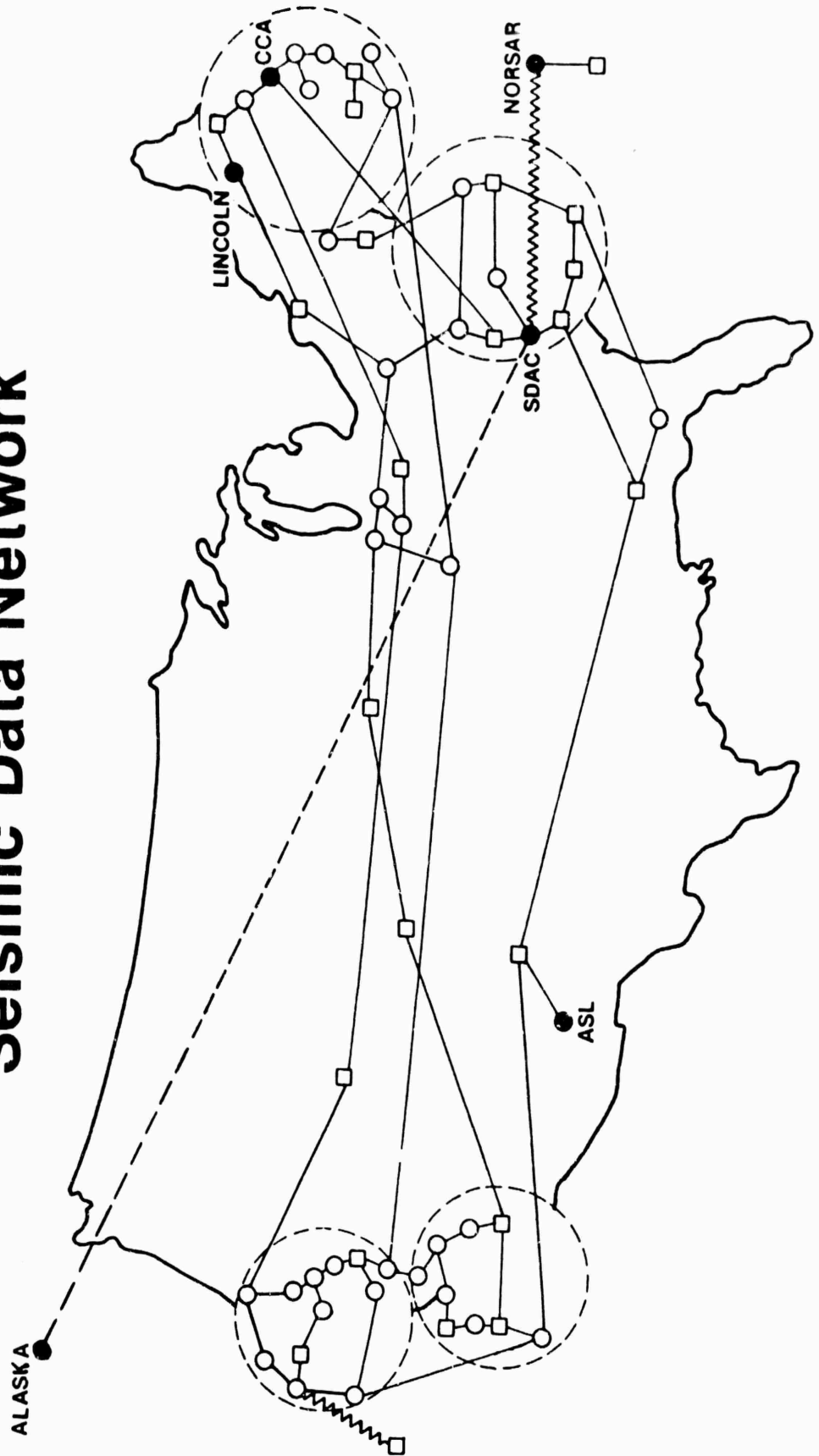

shows the geographic distribution of Velanet instruments and other key components.

The Datacomputer at CCA is the primary storage and retrieval resource in the Velanet. The seismic data activity requires storage of very large amounts of online data. This data includes the following:

1. seismic readings from arrays of instruments, some of which are sent in real time;
2. seismic readings from individual instruments which are forwarded from the Albuquerque Seismological Laboratory by the US Geological Survey;
3. limited status and calibration information on instruments and the Velanet;
4. derived seismic event summary information; and
5. extracted signal waveforms corresponding to events.

Seismic instrument readings can be further subdivided into long period (one sample per second) and short period (ten or twenty samples per second) data.

Since the Datacomputer is not designed to receive data in real time, a special dedicated miniprocessor, the SIP, is used to buffer the real time seismic instrument array data. (Section 5 below discusses the SIP.) The status and event summary data are relatively compact and are of

Geographic Representation of VELA Network

Figure 2.2

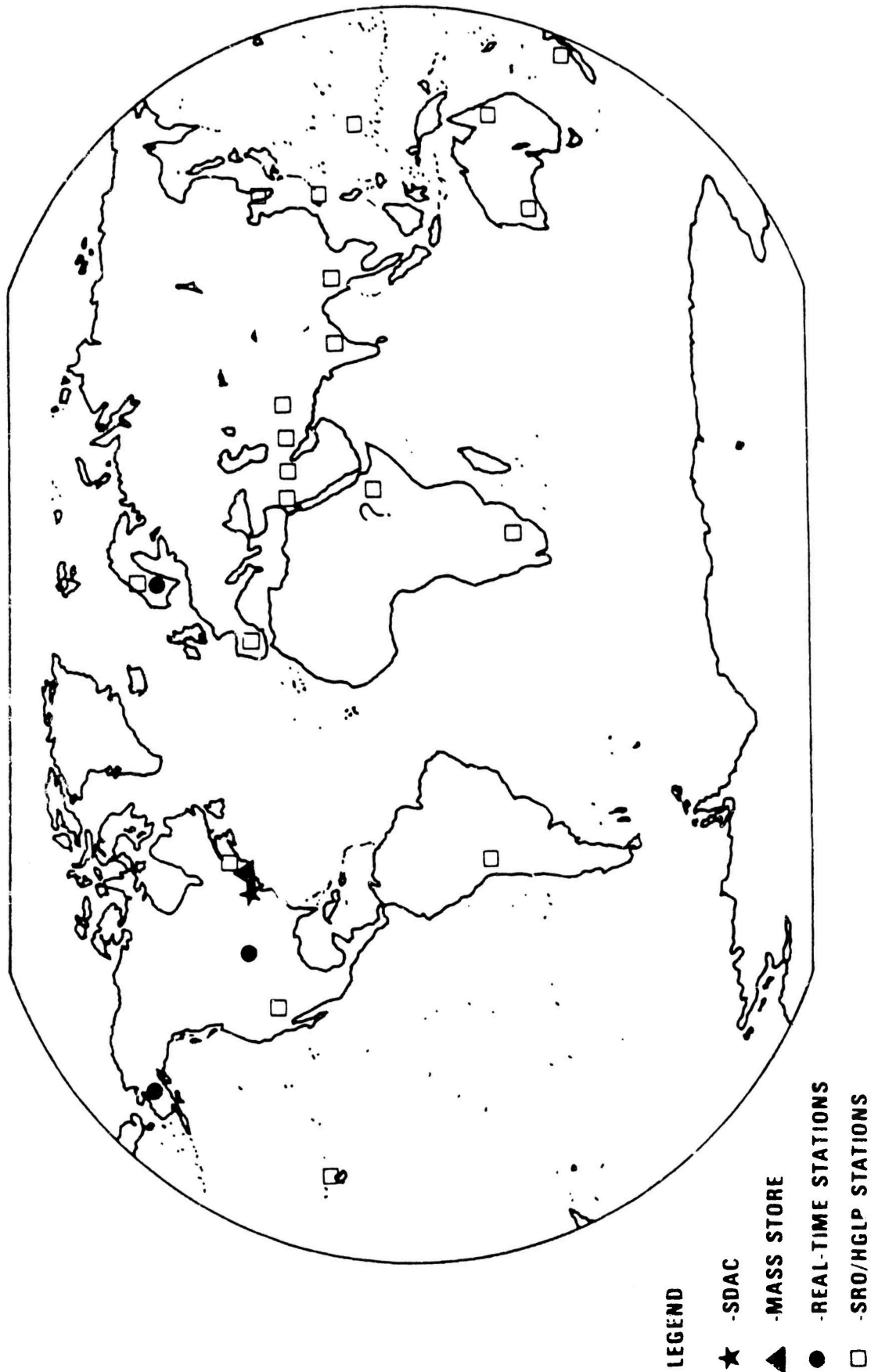

sufficient importance that they are kept on-line indefinitely. Seismic data from single instruments and arrays of instruments is sufficiently voluminous that it fills many reels of tape, most of which are kept off line, in our mass storage system. (Section 6 below discusses the TBM mass storage system in detail.) Seismic Signal Waveform data is the most recent type to be stored in the Datacomputer and is covered in Section 4 below. Figure 2.3 shows the overall accumulation of seismic data in the Datacomputer through the end of 1978.

2.2 The General User Community

The general Datacomputer user community includes a large number and variety of non-seismic users. Some of the organizations from which these users come are listed in Table 2.2.

The amount of information that had been stored in the Datacomputer by non-seismic users, through the end of 1978, was such that it was possible to retain all such information on-line. Figure 2.4 charts the growth in this non-seismic data. Given the amount of seismic data which it is also desirable to retain on line, we expect that in

Seismic Data Accumulated

Figure 2.3

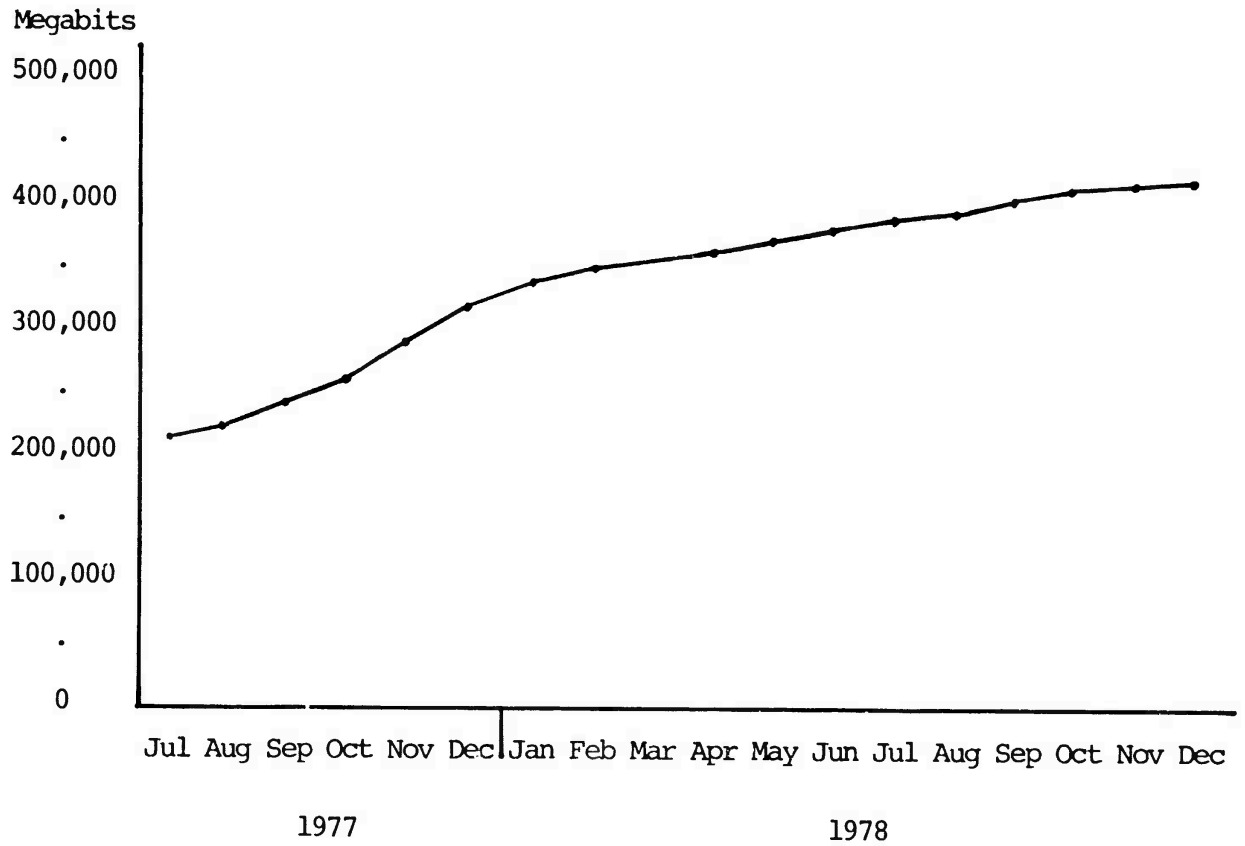

Advanced Command and Control Architectural Testbed (ACCAT)

Air Force Armament Development and Test Center

Air Force Avionics Laboratory

Anniston Army Depot

ARPA

Bolt, Beranek, and Newman, Inc.
Arpanet Network Control Center

Brookhaven National Laboratory

Lawrence Berkeley Laboratory

Carnegie-Mellon University

Computer Corporation of America
Message Archiving and Retrieval Service (MARS)

Department of Energy
Argonne National Laboratory

Digital Equipment Corporation
Federal Systems Group

Gagliardi Systems Group, Inc.

Harvard University
ECL Group
Graphics Group

Intermetrics

Massachusetts Institute of Technology
Artificial Intelligence Laboratory
Center for Theoretical Physics
Laboratory for Computer Science
Programming Technology Division
Database Systems Division
Laboratory for Nuclear Science
Mathematics Department
Plasma Fusion Center

(continued on next page)

Some Non-Seismic Datacomputer Users
(continued from previous page)

Table 2.2

National Bureau of Standards
National Software Works
Rome Air Development Center
Rutgers University
SRI International
Stanford University
 Artificial Intelligence Laboratory
 Stanford University Medical Center
Thames Polytechnic (London, England)
U.S. Army Development and Readiness Command
University of California at Los Angeles
University of Southern California
 Information Sciences Institute
University of Texas at Austin
 Linguistics Research Center
University College London
 Facsimile Transmission Research
White Sand Missile Range

1979 some low-priority non-seismic data will have to be
moved off-line.

Among the significant events for all Datacomputer users in
1978 was the issuance of the completely new Datacomputer
Version 5 User Manual and Datacomputer Technical Bulletin
Number 8 on the Datacomputer status server. Both these
documents are described in Section 3 below.

Non-Seismic Data Accumulated

Figure 2.4

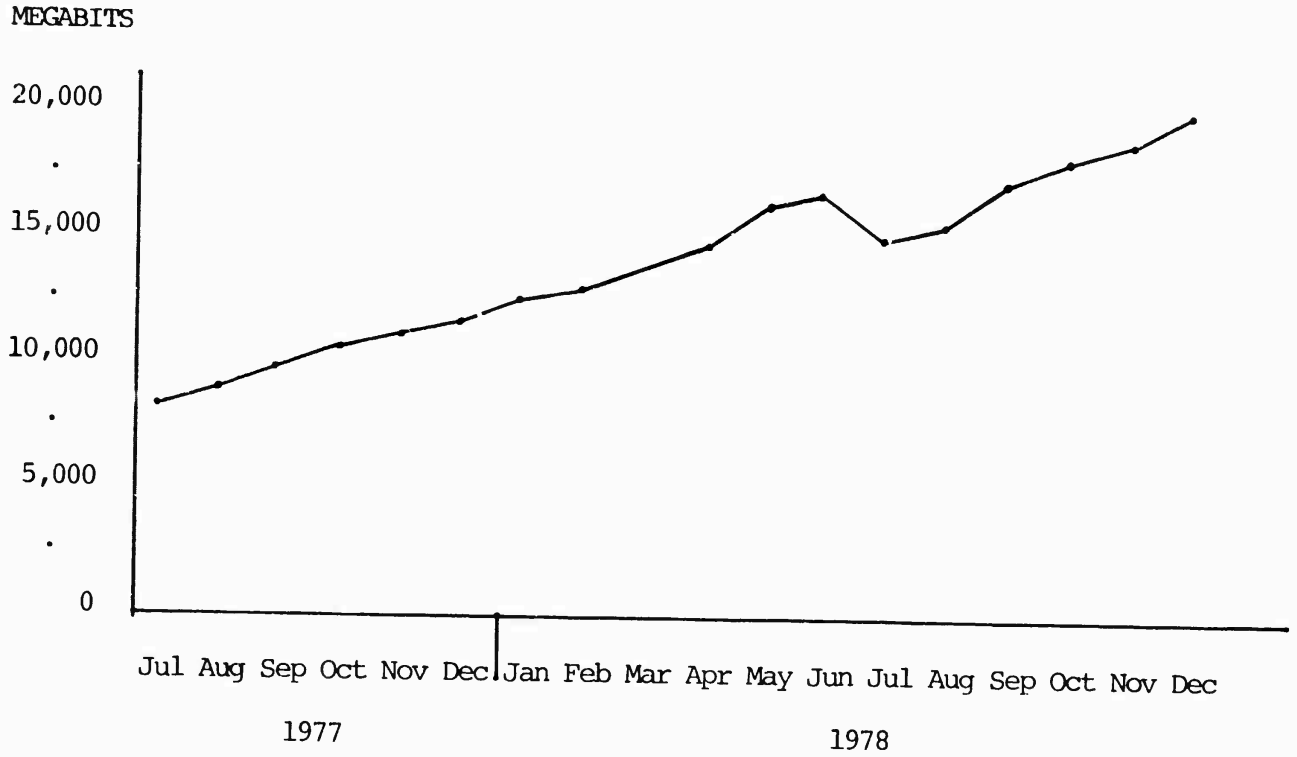

The small interval in Figure 2.4 where the amount of non-seismic data declines was due to CCA assistance to the Bolt, Beranek and Newman IMP LOGGER application. This Datacomputer application stores statistics and event information related to the Arpanet communications backbone in the Datacomputer. Initially it used daily files which were relatively small and inefficient and effectively limited the amount of information that could be kept on-line. The application was converted by CCA to use more efficient monthly files and the decline in Figure 2.4 represents the deletion of the old daily files after the new version of the application was operational.

Among the new Datacomputer users that were contacted for the first time in 1978 were the following: linguist Bob Amsler of the University of Texas, the ACCAT GUARD project at Logicon, the ARPA S1 project, T. Bowerman of the Anniston Army Depot, Tony Michel of BBN, COOPRIDER@ISIB, and Frank Wancho of the White Sands Missile Range.

2.3 Operations and Usage Trends

Figure 2.5 shows the availability of the Datacomputer during prime time (9AM to 8PM business days) (the dotted lines in February show the effect of including the time of the Great Blizzard of 1978 in these figures). Table 2.3 gives a breakdown of the causes of unavailability into several broad classes. It will be seen that almost a factor of two improvement in reducing unavailability has occurred from the later half of 1977 to the later half of 1978.

To enable users with problems to contact a member of CCA's staff, we maintain a Datacomputer trouble telephone number and an Arpanet address (HELP@CCA) to which trouble messages can be sent. The trouble telephone number rings at an answering service that can take trouble messages and beep someone who will respond.

To automatically alert CCA personnel more rapidly in the case of certain types of hardware problems, a background process in the CCA-TENEX system called ALL was modified as described in Section 7.1 below.

Datacomputer Availability by Month

Figure 2.5

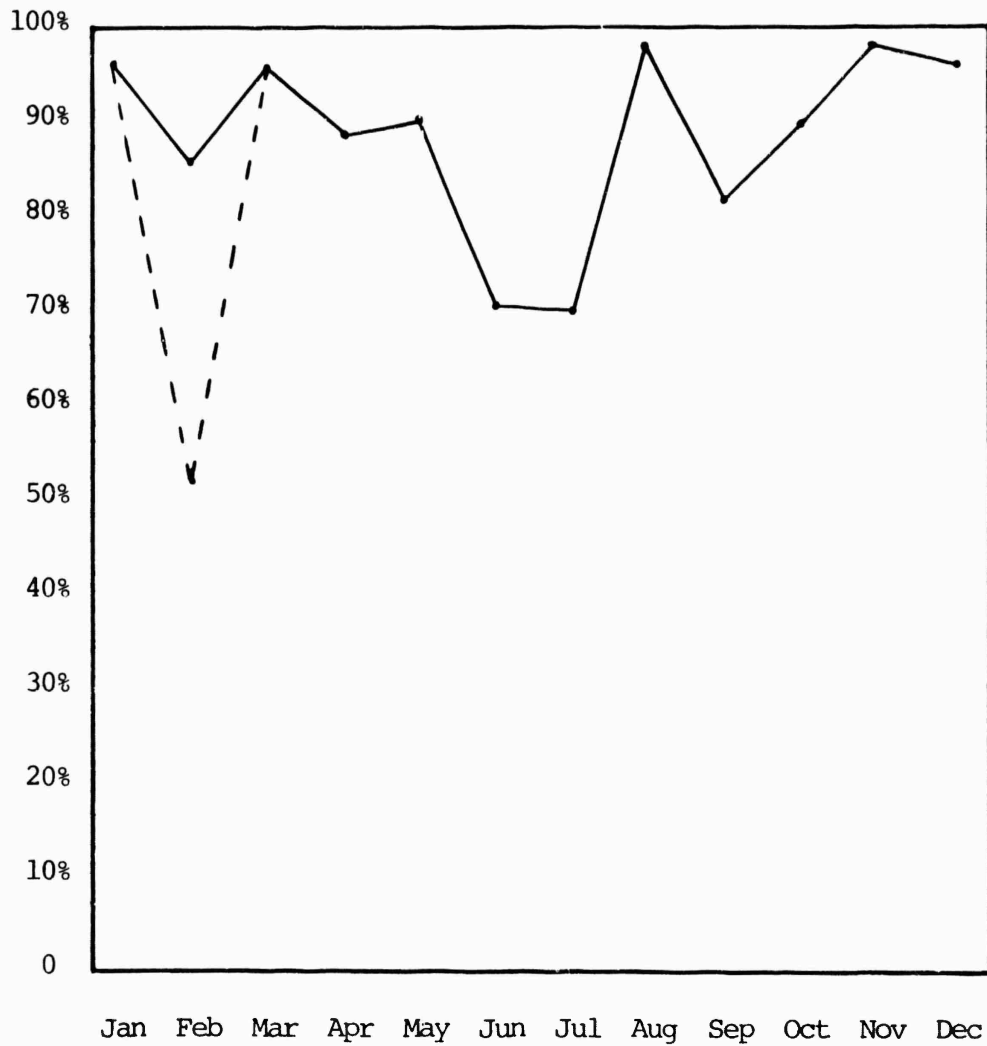

Datacomputer Prime Time Unavailability

Jul - Dec 1977 - 262.8 hours
 Jan - Jun 1978 - 193.0 hours
 Jul - Dec 1978 - 136.2 hours

Breakdown by Cause of Unavailability

<u>Cause</u>	<u>JulDec77</u>	<u>JanJun78</u>	<u>JulDec78</u>	<u>Overall</u>
TBM	65.8	42.5	31.7	50.4
Tenex/DC	27.6	44.3	30.8	33.8
Network	4.6	7.5	28.3	11.0
Operator	1.1	4.1	1.1	2.1
Environment	0.4	1.0	5.7	1.8
Staging Disk	<u>0.5</u>	<u>0.5</u>	<u>2.4</u>	<u>0.9</u>
	100.0	100.0	100.0	100.0

Usage during 1978 is charted in Figure 2.4. The most remarkable usage datum over the course of the year was the tremendous growth of the CCA Message Archiving and Retrieval Service (MARS) which is described in Section 2.4.2 below.

2.4 User Interfaces

The development of interfaces to make the Datacomputer's data storage services more easily accessible is a significant part of the work done by CCA. The following sections cover three interfaces on which work was done in 1978. They range from a new subroutine package to a file storage and retrieval program to a complete message archiving and retrieval service.

2.4.1 DCLINK

DCLINK is a new subroutine package that provides a convenient Datacomputer interface to programs on TENEX and TOPS-20 systems. Written to remedy certain design-level shortcomings of its predecessor, DCSUBR, DCLINK generally embodies improvements in functionality, maintainability, and ease of use. Data was first transferred successfully with DCLINK on 29 November 1978. This section will discuss the motivation for DCLINK's development and then mention some of its significant features.

The Datacomputer and a remote user communicate over at least two network connections: one carrying mainly Datalanguage from user to Datacomputer, another carrying mainly messages from Datacomputer to user. Separate connections may be established to handle data transfers. The Datacomputer occasionally halts a transfer (over whatever connection) while it generates a message (describing, e.g., an error or the progress of staging) and sends this to the user over the message connection. Since a net connection is like a pipeline of finite capacity, it can fill up if the sender puts enough in and the receiver never removes anything. An attempt to write into a "full" connection will hang as the sending system's Network Control Program waits for the receiving system to make some room in the "pipe". One shortcoming of DCSUBR is that it was designed as a single-process program. It can therefore perform I/O on only one connection at a time. It may hang when trying to transfer data because the corresponding Datacomputer job is hung trying to write into the message connection. This can occur because the message connection can fill up while DCSUBR is busy transferring data.

Other factors motivating the replacement of DCSUBR are its buffering method, which allows the loss of Datacomputer messages, an obscure programming interface, and the desirability of new features to support SDD-1.

DCLINK is comprised of multiple independent processes, one of which is always free to read the message connection, and thus DCSUBR-like network deadlocks are impossible. DCLINK's message handling scheme uses temporary disk files to preclude loss of messages due to core buffer overflow.

Emphasis was placed on making it easy to build application programs around DCLINK. The definition of individual routines and their returns represents an attempt to minimize the differences between DCLINK function semantics and Datalanguage semantics. For example, DCSUBR's "connect a Datacomputer port to a local socket" function is replaced by a broader connection-definition function that allows a port to be linked not only with a socket but also with a local data file. Then when the application sends the Datalanguage to execute a data transfer through that port, DCLINK automatically mediates the entire transfer without requiring any other action on the part of the application program.

A major feature of DCLINK is its acceptance of keyword parameters. Instead of passing a fixed set of parameters in registers, application code passes DCLINK the address of a block containing (keyword,value) pairs and individual keywords. The block need contain only what is relevant to a particular call, and the entries need not be

in any particular order. DCLINK validates the contents of the parameter block on each call. The result is tremendous flexibility in the design of both application programs and backward-compatible DCLINK modifications, which is well worth the slight execution overhead in DCLINK's network-bound operating environment.

Another DCLINK feature will permit exploitation of the parallelism available in a computer network. Even if they are not implemented in a multi-process fashion, application programs will be able to execute their own code while the Datacomputer is executing their Datalanguage, and they can catch up with or wait for the Datacomputer at their convenience.

Some other features representing improvements over DCSUBR are:

- support for multiple script files, allowing convenient scripting to both a terminal and a more permanent file
- selective suppression of the scripting of any data transferred over the Datalanguage or message connections

- elimination of redundant buffering during data transfers
- automatic classification of Datacomputer messages into useful categories, with provision for category-based retrieval

To date DCLINK has been incorporated into a version of the existing program RDC and may be retrofitted elsewhere. It is expected to be used in SDD-1 and other new Datacomputer applications.

2.4.2 DFTP: Datacomputer File Transfer Program

DFTP provides a simple interface to the Datacomputer for the storage and retrieval of whole local files. In terms of number of individuals making use of a facility, it is the most popular Datacomputer application.

Several enhancements were made to DFTP in 1978. In particular, to adapt it better to use from MULTICS systems and from other systems when trying to reference files originally stored from MULTICS, the following features were added: a mode in which upper and lower case characters are distinguished in filenames; a reasonable, though limited, way to handle file names with more than

two parts; and several special commands for converting text to and from the 9-bit-byte MULTICS format.

2.4.3 MARS, a Message Archiving and Retrieval Service

The Datacomputer-based Message Archiving and Retrieval System, MARS, has been in service since early in 1978. The System was developed in 1977 under ARPA Contract No. N00014-76-C-0991, as an application package which would utilize the Datacomputer [Dorin & Sattley] for long-term storage of thousands of Arpanet messages and for convenient retrievals of subsets of these messages. Given the quickened pace of communications supported on the Arpanet and the increased volume of electronic message traffic, the archiving of mail on the Datacomputer provides a safeguard against the loss of information, and can alleviate local-site storage requirements for those who wish to keep a record of their correspondence.

An important element in the concept of paperless communications is the elimination of file-drawers full of correspondence and memos. Using the large storage capacity of the Datacomputer and reliable MARS Service, it is possible to keep many years' worth of mail and meeting notes on-line, and available for immediate retrieval. The

extensive indexing performed on the message when it is filed allows it to be retrieved in response to many different requests, as if, in a paper-filing system, many duplicate copies were filed in different folders.

A technical memorandum which describes MARS' usage of the Datacomputer has been distributed as Network Working Group RFC #744, NIC #42827. In April, 1978, an informal report on the first few months operations was distributed to MARS users. [Sattley c]

Since the inception of MARS service, the amount of mail received for archiving has grown to an average of 1000 messages per week; this represents a net monthly saving of 1600-2000 pages of local disk storage for the users of MARS. Netwide users include several teleconferencing groups; in particular, all of the MsgGroup, Header-People, SUPDUP-Group, and EMACS-History messages are available to all Arpanet correspondents. We are also storing Internet-Working-Group and Transmission-Control-Protocol meeting notes as well as summaries of net host traffic.

Maintaining and operating MARS as a service to the Arpanet community is expected to continue, with new features and operational improvements being incorporated as time and resources permit. Figure 2.6 below reflects the growth of the message database during 1978.

MARS: Cumulative Summary of Messages Filed Figure 3.1

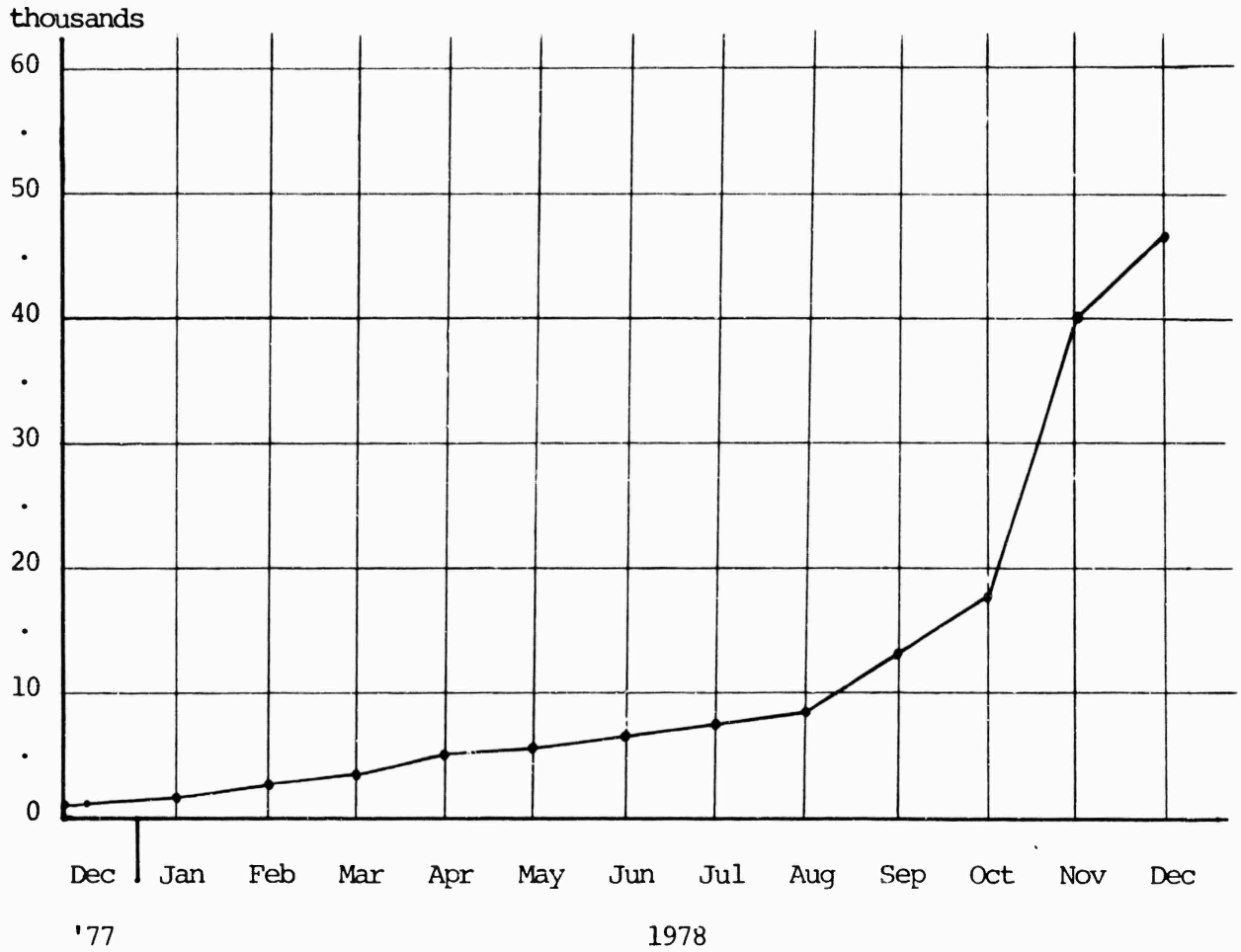

3. Datacomputer Development

The Datacomputer software is in a primarily operational state, rather than in a developmental phase. As a result, modifications are of an evolutionary sort. Below are described the changes that occurred in 1978 in the Datacomputer, its documentation, and a special status server program for the Datacomputer. This section ends with a brief mention of some future development prospects.

3.1 Version 5

The Version 5 Datacomputer was put into service early in 1978 replacing the Version 4 Datacomputer. There were two new features of particular significance in Version 5 as described below.

3.1.1 Message Deadlock Solution

In the past, network communication lockups were found to occur with the Datacomputer under certain conditions. They were due to simple user programs that are unable to listen for Datacomputer error or information messages when they are transmitting to the Datacomputer or while they are receiving data from the Datacomputer over a separate connection. Particularly with the small network buffer allocations some users provide, it is possible for the Datacomputer to send enough message text to the user that the buffers available for that channel fill up. This results in the Datacomputer waiting for the user program to read some of this message text and free up some space. Unfortunately, the user program may be completely intent on sending or receiving data for which it is in turn waiting for the Datacomputer. Hence a deadlock.

An elegant and complete solution is for user programs to have multiple processes so that one can always be listening for messages from the Datacomputer. (This technique is used in DCLINK as described in Section 2.4.1.) However, multiple processes may not be supported

on the user's host system or the user may not wish to implement them. A solution for such simple one-process users has been incorporated in Version 5. It is an optional mode in which a limited number of messages that would normally be sent to a user are inhibited during data transfers and are given to the user all at once at the end of the transfer. Of course, error messages that are sufficiently severe to terminate the transfer are sent and also cause any inhibited messages to be sent to the user.

3.1.2 Pre-Compiled Request

In some cases, it is desirable to execute a Datacomputer request several times. (The request may have different effects depending on the value of various data files or streams or its repeated execution may have some desirable cumulative effect.) It is more efficient in such a case to store the request in a partially compiled form rather than having to re-input it each time.

The previous version of the Datacomputer provided such a stored request facility only within a single user session. The Version 5 Datacomputer provides a more general pre-compiled request facility in which requests can be stored in the Datacomputer between sessions, in a manner

similar to files. The original text is also stored and, if certain conditions have changed so as to invalidate the pre-compiled version, the stored request is automatically re-compiled on execution.

3.2 Version 5 User Manual

For several years, each new major version of the Datacomputer was accompanied by an update to the previous complete manual, the Version 1 User Manual. In early 1978 however, a completely new manual was published. This manual had been in preparation since mid 1977.

The manual includes chapters which cover the following topics from a user viewpoint:

- . Datacomputer Facilities and Applications
- . The Datacomputer Operating Environment
- . The Directory
- . Data Security
- . Data Description
- . Datacomputer Commands
- . Elementary Data Manipulation
- . Efficient Retrieval Techniques
- . File Groups

- . Chaptering and Variable-Length Updating
- . Datacomputer Space Allocation
- . Interface to the Datacomputer

The Manual also has a thorough index and three appendices which give a syntax summary of Datalanguage, a list of Datacomputer reply messages, and charts of Datacomputer character conversions.

3.3 Datacomputer Status Server

It is frequently useful for remote users to be able to inquire about the general status of the Datacomputer and about the status of the network connections to the various remote jobs using the Datacomputer. The most common cases are those in which the Datacomputer appears to be unavailable and those in which the user is connected to and using the Datacomputer but is concerned over the status of his request.

To satisfy these needs, an independent status server program has been implemented. This server runs at CCA-TENEX but as a separate job independent of the Datacomputer. When the user connects to this server by using the DCSTAT program (or Telnetting to socket 141

(decimal) at CCA), a message is sent to the user reflecting most facets of Datacomputer status. This message includes a general status note set by CCA personnel. Since it is presumed that anyone interested in Datacomputer status has some software capable of reading Datacomputer reply messages, the status server formats its status message using the same rules that actual Datacomputer replies obey.

This year, the status server was augmented by adding information to that given for the status of network connections. As well as giving the socket numbers, network, and buffer status of such connections as seen from the Datacomputer, it now also gives the total number of bits that have been transmitted on open connections. This is particularly useful on connections where the receiver is much slower than the transmitter, resulting in buffers filling up and the transmitter being blocked most of the time. Previously it was hard to tell if any progress was being made; now it is possible to see the number of bits transmitted increasing.

A technical bulletin documenting the status server was prepared and distributed with the Version 5 User Manual.

3.4 Version 5/2

Improvements were made in Version 5 during 1978 resulting in Version 5/2 which, after testing, went into full operation on 13 December. These changes consist of a number of upward compatible additions and one significant bug fix.

The bug fixed was related to a low probability failure in interlocking between several users who are trying to access the same data while the data is being moved from TBM storage to disk storage. The problem first made itself evident on April 1, 1978, when two users were trying to read the same seismic data. A temporary fix was used until Version 5/2 was installed.

The several enhancements made in Version 5/2 can be divided into operational improvements and user facilities. The user facilities added were requested and funded by the SDD-1 project under a separate contract (No. N00039-77-C-0074). The user facilities included an addition to the MODIFY command to allow users to change file names, a new REDESCRIBE command to allow limited changes to the description of a file without affecting the

data stored in the file, and a new SUBSTRING function to allow the extraction of substrings.

The operational enhancements were those necessary to provide a family of additional operator commands for investigating and repairing problems with parts of the Datacomputer directory. This includes a command for printing limited information on all active directory nodes and commands for printing various types of detailed information on particular directory nodes. If a problem exists and can be solved by backing up to another version of the data for a file, a command is provided for this. In cases where other ad hoc steps are necessary, the commands provide aid in automatically reading in the relevant information, locking it so other users can not interfere, and writing the possibly modified information back afterwards. Before these commands were added, it was almost always necessary to run the Datacomputer in a stand-alone operator only configuration to investigate and fix such problems. Now, when they occur, they can be fixed more rapidly and usually without halting normal service.

3.5 Future Development Prospects

An extensive list is kept of possible improvements in the Datacomputer system. Several items on this list related to improved operation are expected to be given high priority in 1979. These include moving more Datacomputer directory information out of cramped TENEX disk space into Datacomputer controlled storage space, and possible efficiency improvements, especially on large files such as are frequently encountered in the seismic application.

In addition, it is planned to implement direct Datacomputer access from the National Software Works system using the MSG interprocess communications protocol. A significant upgrade to the TENEX operating system under which the Datacomputer operates will have to be made to support this facility.

4. Signal Waveform File Development

In August 1977, the concept of a compacted database of event-related seismic waveforms was developed jointly by representatives of ARPA-NMRO, Vela Seismological Center (VSC), Lincoln Laboratories Applied Seismology Group (LL-ASG), and the Seismic Data Analysis Center (SDAC). The data collection would be stored as a set of Datacomputer files, the Signal Waveform Files (SWF), and would contain extracted seismic readings -- those directly associated with events in Event Summary Files (ESF).

Both SDAC and CCA will contribute to this SWF database: SDAC is responsible for storing array data and other data readings which do not exist in any other form on the Datacomputer. Such data will be stored directly into the Signal Waveform File in segments corresponding to entries in the Event Summary Files.

CCA is responsible for storing Seismic Research Observatory (SRO) data segments which already exist on the Datacomputer, but which are embedded in the very large basic seismic data files: the non-array long-period files (NLPF) and the non-array short-period files (NSPF).

Readings containing the data for seismic events which have been detected and marked in an Event Summary File by SDAC, are simply copied into the Signal Waveform Files, once these stretches of basic data have been located and delimited. Figure 4.1, based on a diagram supplied by SDAC [TELEDYNE], depicts the overall data flow through the system and gives an indication of the order of processing.

In 1978, CCA designed a program [EASTLAKE & SATTLEY a] to accomplish its part of the project. The SWF-D ("D" for Demon) program was implemented under this contract. Figure 4.2 shows the data of concern to SWF-D. The work has been described in detail in previous technical reports submitted by CCA [SATTLEY a, SATTLEY b]; a general description is given below in Section 4.1.

CCA also participated in the general planning of the SWF project [EASTLAKE & SATTLEY b]. Representatives from CCA attended meetings at SDAC on 16 January and 13 April to discuss and plan the SWF. We also wrote two memoranda, which were relevant, as follows: "Comments on the SDAC Mass Store Retrieval Guide" (17 January) and "TBM Drive Allocation and the SWF" (20 March). Later in the year, two changes were made in the Event Summary File description, at CCA's suggestion, for the SWF project. They were the addition of a virtual index and the

SWF Data Flow

Figure 4.1

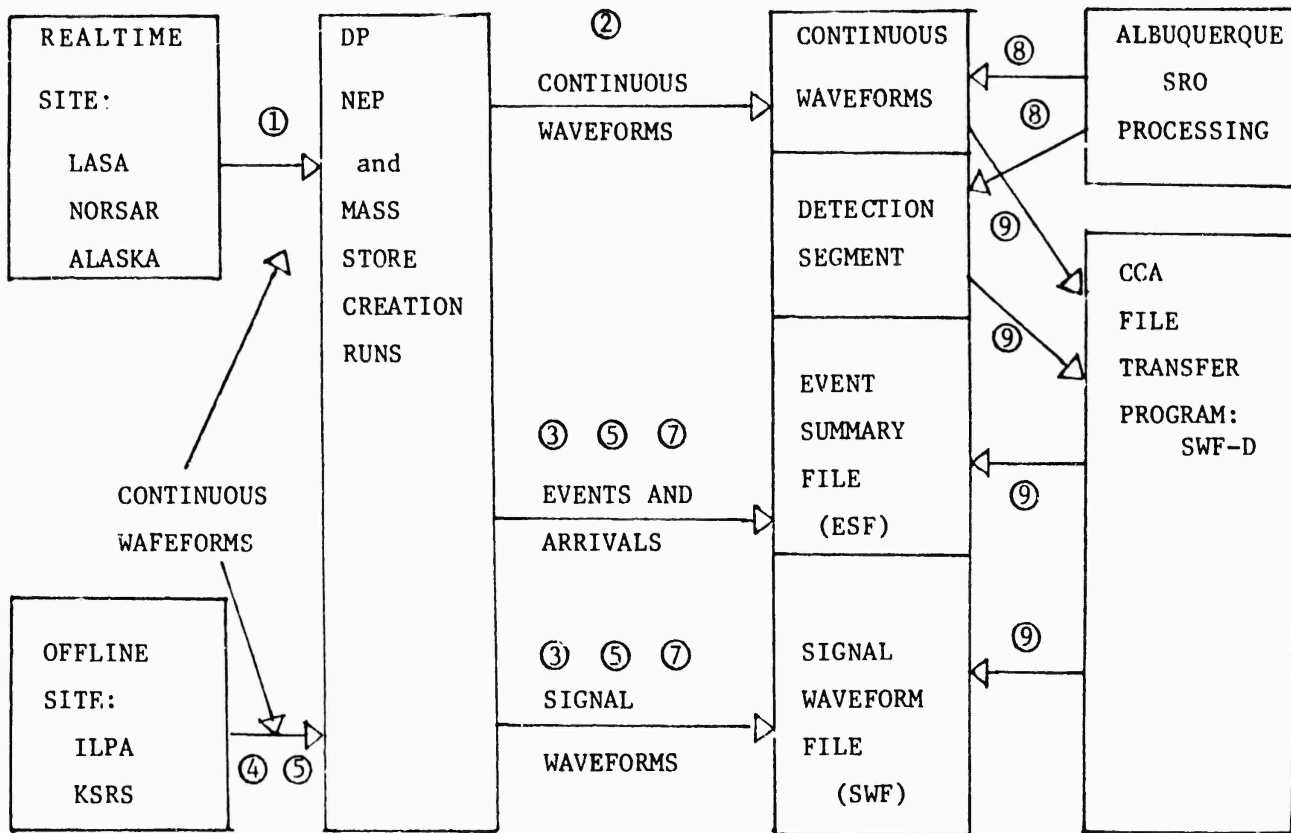

- 1 - Waveform data from realtime sites arrives at SDAC
- 2 - Some data from realtime site goes to Datacomputer
- 3 - ESF/SWF including realtime site signal waveforms go to Datacomputer
- 4 - ILPA field tape arrives at SDAC
- 5 - ILPA signal waveforms go to Datacomputer
- 6 - KSRS field tape arrives at SDAC
- 7 - KSRS signal waveforms go to Datacomputer
- 8 - Albuquerque reviewed SRO data goes to Datacomputer
- 9 - CCA FILE TRANSFER PROGRAM completes signal waveforms

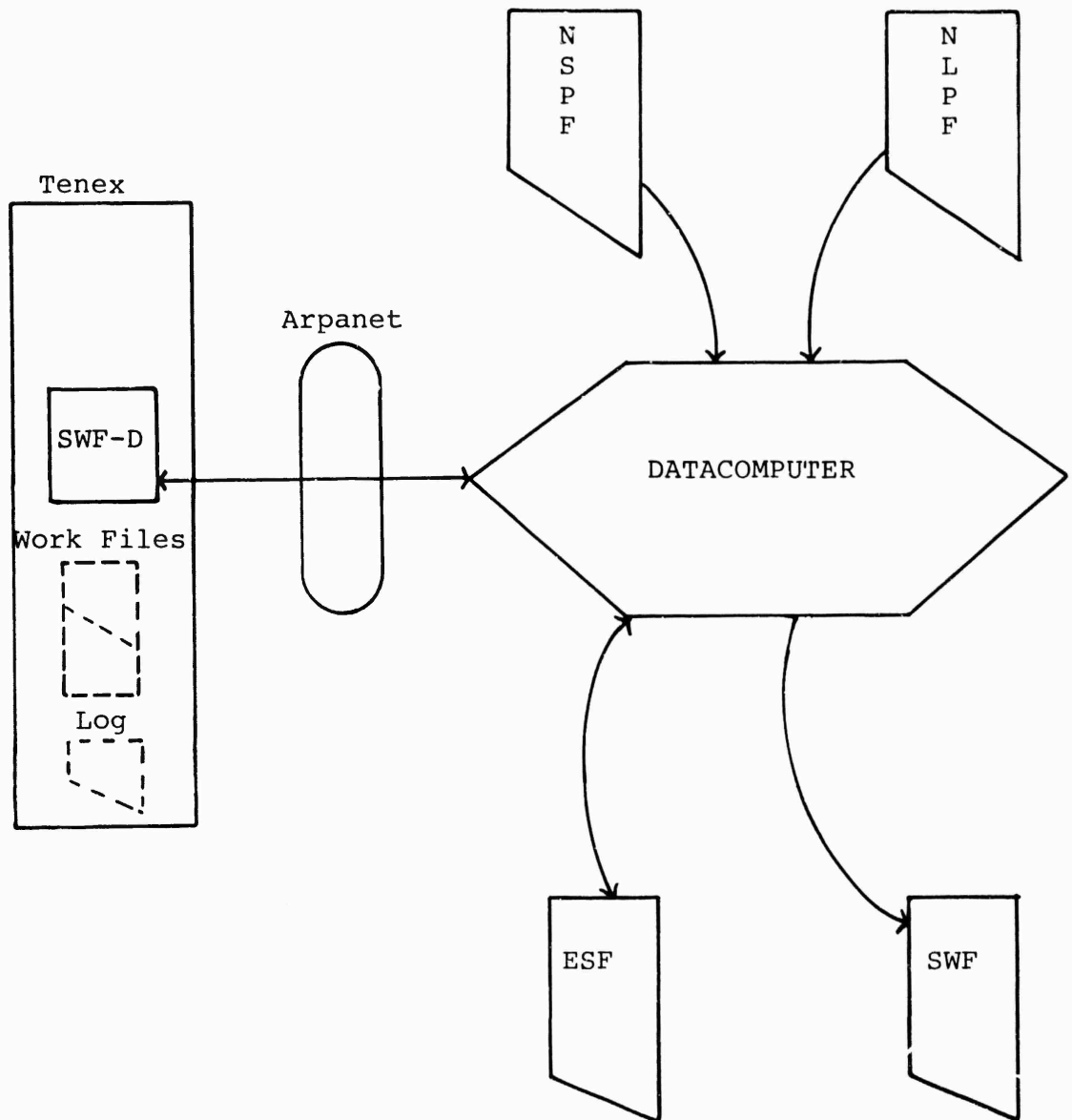

elimination of two unnecessary inversions that made it impossible to update certain fields.

4.1 Tasks of SWF-D

The SRO seismic data, from which SWF-D must extract portions, is stored into the Datacomputer from magnetic tape by the Albuquerque Seismological Laboratory. The data arrives at the Datacomputer several months after real time. Long period SRO data is recorded and later transmitted to the Datacomputer continuously. The higher bandwidth short period SRO data is only recorded and later transmitted to the Datacomputer when it exceeds a threshold set at the seismic instrument. Because of this data routing, some of the SWF candidates may not yet be on file at the time they are requested, or they may be only partially available.

For the long-period files, expected data availability is based upon the date(s) specified in the periodic report of "Digital Seismic Data Transmitted to Datacomputer" via Arpanet message from the Albuquerque Seismological Laboratory (ASL).

For short-period files, determining data availability is a bit more complicated. To help in checking for which readings may be available, the SWF-D program pre-processes the short-period files and generates a list of the recorded detections on each full cycle through its task queue. The list, sorted into monthly Datacomputer files, the SPDET files, is used as a map which can be consulted for deciding whether to attempt to retrieve the desired data.

The SWF-D program comprises separately-compilable components -- modules -- which operate independently of one another to accomplish a set of prescribed tasks:

- The ESF-checking Module, to accumulate requests for moving waveform segments by sifting the Event Summary Files for flagged arrivals;
- The Waveform-copying Module, to copy the desired long-period and short-period waveforms into the Signal Waveform Files; and
- The SPDET-mapping Module, to generate a map of the short-period detections for use when determining expected data availability.

Each program module is capable of recognizing when there is work for it to do, logging in a separate Datacomputer job, generating a script file for the session, interacting with the Datacomputer to manipulate the relevant files, reporting task progress on an operations log file, and terminating the session when a pre-programmed quota of work has been performed.

Because of the program's modularity, each task-handler could be tested individually and, when running error-free, could be scheduled for regular operation in detached background mode. The ESF-checking and SPDET-mapping Modules have already been placed in service; they have worked their way through the set of NSPF and PESF files beginning with the data for 1 January 1978, and have recently reached 25 July 1978. The Waveform-copying Module has been operated in debugging mode only and will need further testing for bad-data protection and for correct handling of massive data.

4.2 SWF Usage

The SPDET files are already being used in studies conducted by the Lincoln Laboratory Applied Seismology Group [LINCOLN].

It is anticipated that the attainment of full service operation in 1979 will result in an increase in Datacomputer service to the seismic research community.

5. The SIP

The SIP is a dedicated minicomputer communications system developed and operated by Computer Corporation of America. It interfaces real time seismic information from the Velanet to the Datacomputer [DORIN & EASTLAKE].

Below we give a general description of the SIP and the changes in the SIP and the seismic data flow in 1978.

5.1 General Description

A primary function of the world wide Vela Seismological Network (Velanet) is the collection of real time seismic data from arrays of seismometers. This data is sent over leased lines and the Arpanet to the Communications and Control Processor (CCP) at the Seismic Data Analysis Center (SDAC) in Alexandria, Virginia. From the CCP this data is immediately distributed to various processors and to the Datacomputer, via the SIP, for storage as shown in Figure 5.1. This figure also shows the SDAC and Lincoln Laboratories UNIX systems which are presently the primary

SIP Data Flow

Figure 5.1

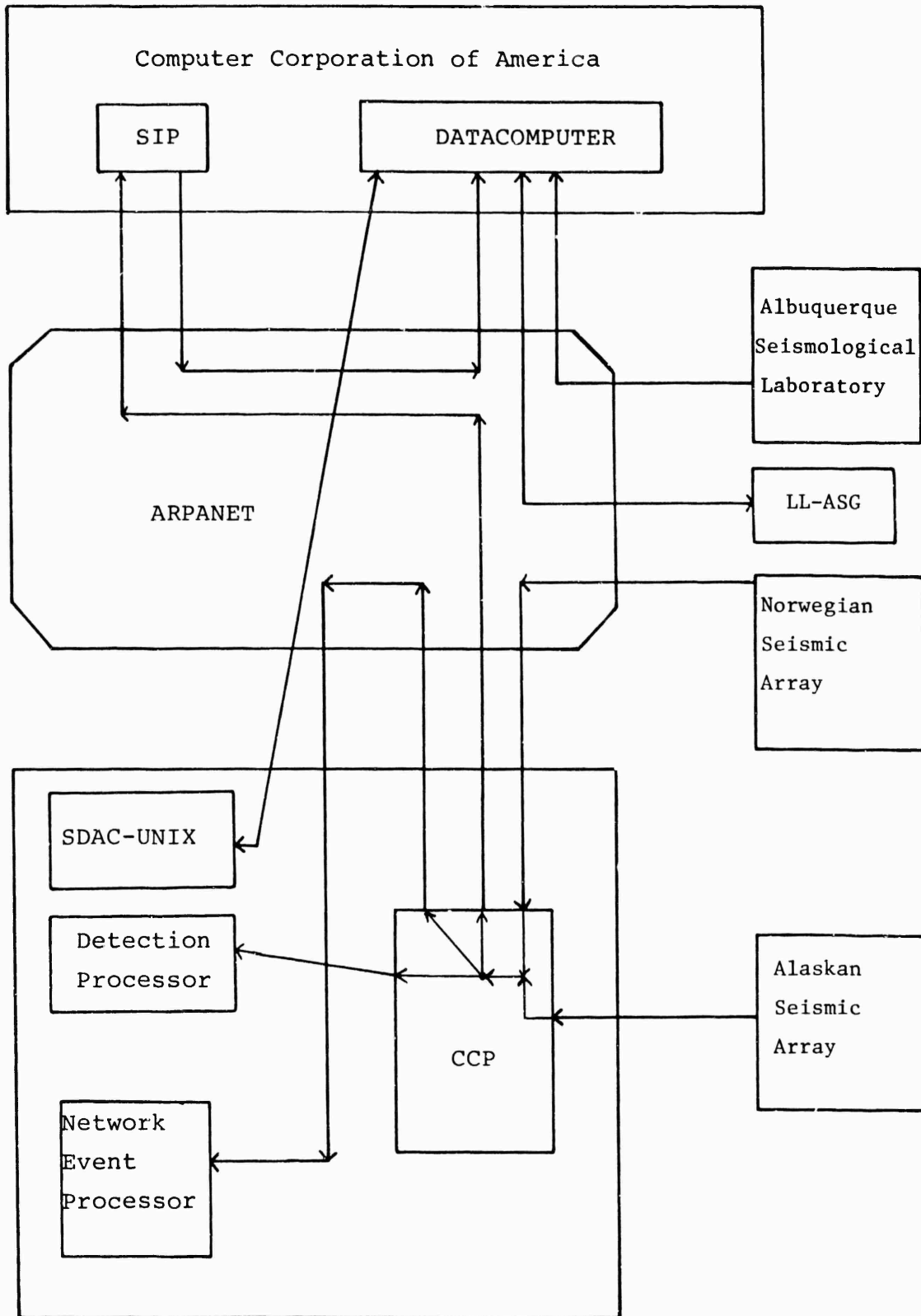

systems used by researchers retrieving seismic data from the Datacomputer.

The components of the Velanet that handle real time seismic array data, except for the Datacomputer, are dedicated systems designed to receive data in real time. The Datacomputer, however, operates within a non-real-time operating system and serves the general Arpanet community as well as the Velanet. Furthermore, it is occasionally unavailable due to scheduled and unscheduled maintenance work. To isolate the Datacomputer from these real time requirements, the SIP was implemented to receive real time data from the CCP, buffer and reformat this data on disk, and periodically forward the data to the Datacomputer.

The SIP's hardware structure is shown in Figure 5.2. It is implemented on a DEC PDP-11/40 computer. The SIP has an Arpanet interface, two RP-04 disk drives for buffering data, an operator's terminal, and a status display screen. With the present bandwidth and disk structuring, about two days of data can be held by the SIP.

Besides processing seismic data, the SIP software provides for operator communications between itself and the CCP. It also sends messages to the CCP for each chunk of data when the data has been properly filed in the Datacomputer.

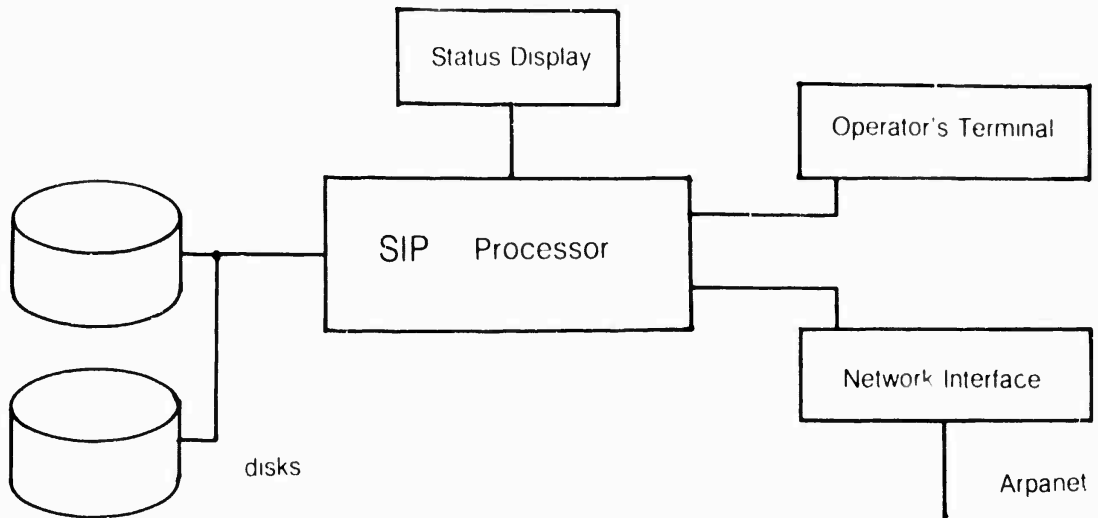

5.2 SIP Development in 1978

As set up at the end of 1977, the SIP received data from three seismic arrays: LASA, the large aperture seismic array in Montana; NORSAR, the Norwegian array; and ALK, the Alaskan array. Each of these arrays provided both long period (one sample a second) and short period (ten or twenty samples a second) seismic data.

Since it was expected that the number of arrays would increase, the SIP's directory structure was modified. It had originally allowed for up to 4 sites. The modifications that were initially implemented provided for up to 8 sites and modifications for higher numbers were investigated. Further details are given in CCA Technical Report 79-08 [Eastlake b].

However, the expected increase in the number of sites has not occurred. Instead, the present direction of development for the seismic system is towards the SWF or Signal Waveform Files. These files are intended to include all the "interesting" planet data and are described in Section 4 above.

The changes that actually occurred during 1978 were a cessation of real time short period data being sent to the SIP, which required a very minor modification to the SIP, and later the termination of data from the LASA site when that site was permanently decommissioned.

The reliability of the SIP was demonstrated during the Great Blizzard of 1978. Despite repeated local power failures, the SIP successfully restarted itself whenever power was restored.

We continue to receive and process real time long period data through the SIP, and the SIP directory system modifications are still in place to enable us to easily adapt to data from an increased number of seismic arrays when the need arises.

6. The TBM Mass Storage System

It is the TBM Mass Storage System that enables the Datacomputer to store and access such a large volume of on-line data. The TBM is described below. This description is followed by a section on some 1978 enhancements to a TBM utility program and a section on TBM reliability.

6.1 General Description

The CCA Datacomputer is equipped with the first public installation of the Ampex Tera-Bit Memory (TBM) System [Eastlake a]. This device uses video tape technology to achieve a maximum on-line capacity of 3 trillion bits on 64 tapes. Maximum seek time to any bit is 45 seconds. Maximum data transfer rate is 5.3 million bits per second.

The TBM at CCA is equipped with two dual tape transport modules so at most four tapes, or 175 billion bits (equivalent to 220 IBM 3330 type disk packs) can be available on-line. All equipment between the transports

and the Datacomputer central processor is non-redundant in the CCA configuration as shown in Figure 6.1. There is one transport driver (necessary for a tape to be in motion), one data channel (necessary to encode and decode digital information to and from the broadband analog signal on tape), one system control processor to coordinate and direct the other units, and one channel interface unit that connects the TBM system to the Datacomputer's PDP-10 system.

6.2 TBMUTL Enhancements

In order to maintain the TBM, it is necessary to test its operation from the CCA PDP-10 host computer. This is normally done daily after the early morning TBM maintenance period. TBMUTL (for TBM UTiLity) was written to answer this need. It provides facilities ranging from the ability to execute all the individual TBM device operations available through the modified CCA TENEX system to a convenient way of executing a general canned test on all TBM drives sequentially.

TBMUTL is relatively mature and only two minor enhancements were made to it this year. First, some operations were added to the most commonly used canned

CCA TBM Hardware Structure

Figure 6.1

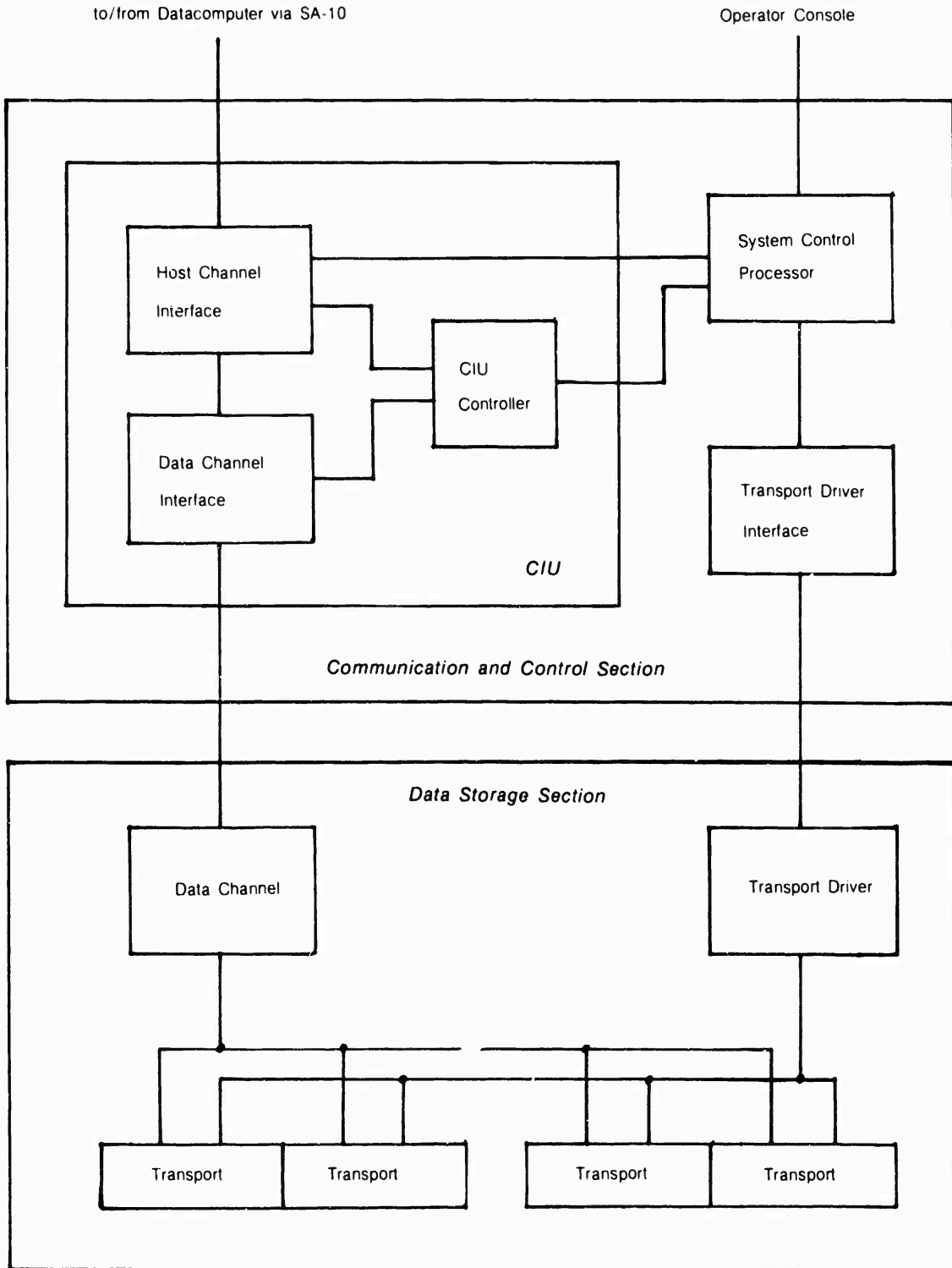

test so as to more thoroughly check TBM operations. One of these new operations deliberately caused a minor error to check the proper operation of most of the error detection and processing logic. Secondly, the automatic sequencing through drives for the predefined canned test sequences was made more general. Previously it was possible only to specify all drives or any single drive for a test. As a result, if a drive was unavailable, it was necessary to have a person in attendance to sequence the test through the drives skipping the bad one. It is now possible to specify any set of drives for the test to sequence through.

6.3 TBM Reliability

As shown in the Table 2.3, the TBM is the least reliable of the components making up the Datacomputer. The reason for this is that the TBM installation at OCA is, except for the four tape transports, entirely non-redundant.

An unfortunate aspect of the TBM periods of unavailability is that they are relatively long. It is not a matter of a system crash or the like, where service can be restored within, say, an hour. Rather it is an occasional obscure failure deep within the controller hardware that may not

Datacomputer TBM Prime Time Unavailability

Jul - Dec 1977 - 172.9 hours
 Jan - Jun 1978 - 82.0 hours
 Jul - Dec 1978 - 43.0 hours

Breakdown by Hardware Module Type

	<u>JulDec77</u>	<u>JanJun78</u>	<u>JulDec78</u>	<u>Overall</u>
C.I.U.	47.5	29.3	11.0	37.2
Data Chan.	21.3	22.0	-	18.6
TransDriver	10.6	-	-	6.2
Drives	7.9	16.8	85.5	21.3
S.C.P.	-	-	-	-
Undiagnosed	<u>12.7</u>	<u>31.9</u>	<u>3.5</u>	<u>16.7</u>
	100.0	100.0	100.0	100.0

be fixed for many hours or, in some cases, a couple of days.

Table 6.1 gives a detailed breakdown of reasons for TBM non-availability from mid-1977 through the end of 1978. Note that the hours of prime time unavailability due to the TBM have been declining markedly.

Most TBM problems were associated with controller modules of the TBM except for an unprecedented drive related problem in the second half of 1978. Specifically, in July 1978, our only incident of significant damage to TBM tape with user data on it occurred. The unavailability time

PRESENT CCA TBM

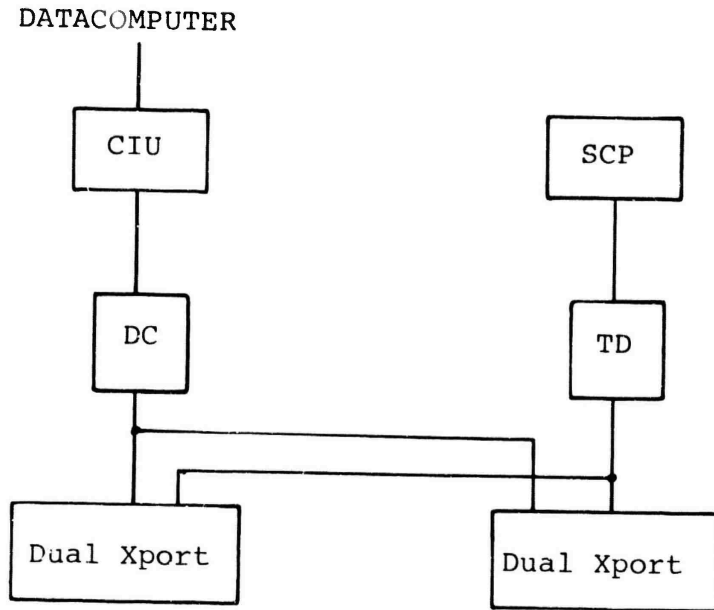

POSSIBLE REDUNDANT TBM

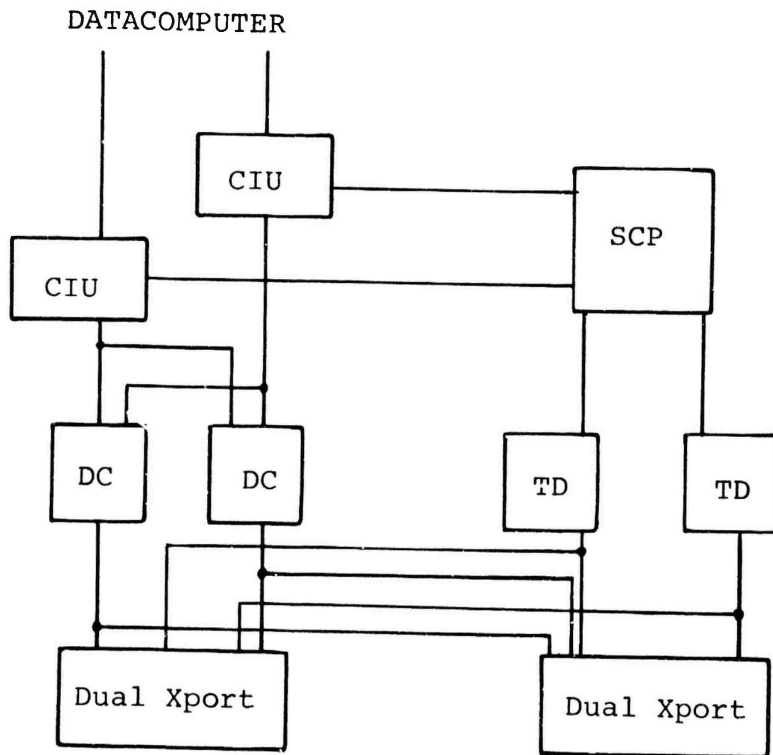

indicated includes the time it took to fix everything up using the backup data copies that the Datacomputer maintains.

Figure 6.2 shows a simplified block diagram of the present CCA TBM installation and of a possible redundant version. All more recent TBM installation., such as the one at the National Center for Atmospheric Research in Boulder Colorado, are more redundant than the CCA installation and have much better availability statistics.

7. The CCA TENEX System

The Datacomputer runs as a single, although unusually large and complex, user job on the CCA-TENEX host computer under the TENEX operating system. Many modifications had to be made in TENEX to accommodate the special requirements of the Datacomputer job and the special hardware in use on the CCA Datacomputer system. Figure 7.1 shows the hardware structure of the system.

The general modifications and additions that had to be made to CCA-TENEX include both changes to the operating system and additional utility programs that are not part of the Datacomputer proper. These modifications and additions include the following:

1. improved efficiency in the network interface code for the high volume file-transfer-like data streams sent and received by the Datacomputer;
2. device code was implemented for using the Ampex TBM Mass Storage system and CalComp 3330-type disks;

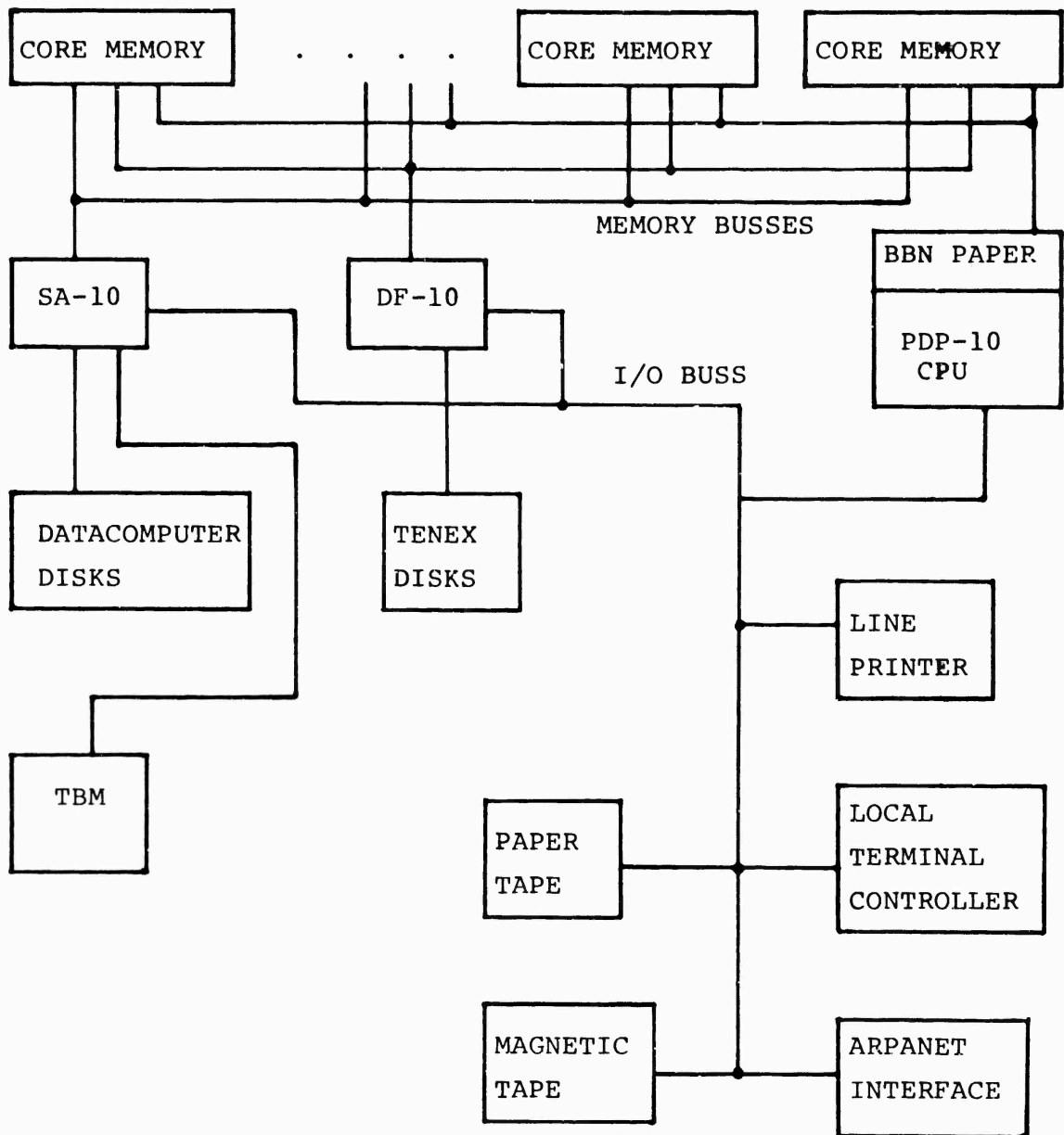

3. additional statistics gathering code was added to aid optimization and analysis of operating system performance;
4. a separate network server program was augmented to provide status output on the Datacomputer [Eastlake c];
5. a utility program called TBMUTL was written to assist in TBM maintenance;
6. a utility program was implemented called ALL that runs as a background job in CCA-TENEX and keeps an eye on various system resources; and
7. other utility programs were added including one for cleaning up old audit trail files of user sessions in the Datacomputer's TENEX directory.

Enhancements made and problems encountered in 1978 are described in the following sections.

7.1. Datacomputer Related Changes

Three Datacomputer related changes were made in the CCA-TENEX system in 1978. One involved a change to the background program ALL, one related to handling certain errors indicating that the TBM was unavailable, and one involved expansion of available disk space.

To maximize Datacomputer availability, it is desirable to bring hardware failures affecting the Datacomputer to the attention of someone who can rectify the situation. To this end, the ability of the ALL program (named after the cry of the watch: "All's Well") was enhanced. In the past, in addition to appending periodic statistical output to several log files maintained by CCA-TENEX, ALL monitored the load average and amount of free TENEX disk space. If the system is excessively loaded or has a dangerously low amount of disk space available, a warning is periodically printed out on all terminals. Now ALL also checks for problems with a TBM drive, with the TBM or staging disk subsystems, or with the CCA-TENEX network connection. For problems with any of these, a warning message is similarly broadcast to alert CCA personnel and minimize the time to start corrective action.

As mentioned above, one of the items checked by ALL is a flag that indicates that the TBM subsystem is not available. Some very high level errors that were associated with the hardware common to the TBM and staging disk subsystems did not set this flag. Additional code was inserted so that if such errors were occurring, the TBM subsystem would be marked as unavailable.

During the early parts of 1978, TENEX disk space was becoming increasingly tight due to the growth in the Datacomputer directory, audit trail, logging, and accounting files. Although in the longer run it is hoped to move much of this information to other storage than TENEX disk space, the solution adopted in the interim was to add a 7th RP02 disk to the system. This required reassembly of the system and, because the TENEX system has no explicit notion of separate physical volumes, a complete dump and reload of all information stored in TENEX disks at the time.

7.2 Other Changes

A new version of the File Transfer Protocol user program was installed at the beginning of July, 1978.

In late July, new versions of BCPL and BDDT were installed. BCPL is a high level language that has become the preferred tool in developing new P-10 software systems at CCA. BDDT is a debugger especially designed for debugging programs written in BCPL.

For use in conjunction with BCPL, which distinguishes upper and lower case letters, and general documentation, a program called XLA180 was developed near the end of 1978. This program allowed more effective use of our LA-180 low speed printer by properly adjusting output to the printer's timing characteristics and thus avoiding data loss due to printer buffers overflow.

7.3 CCA-TENEX Network Problems

We had some problems related to our Arpanet connection during 1978 as shown in the unavailability Table 2.3. Almost all of these can be traced to work on the PLURIBUS IMP at CCA. This IMP is our local Arpanet communications node and all network communications must go through it. Although it is a multi-processor IMP and was in fact expanded from two to three processors during the year, it has only one bus. Consequently any hardware work on the IMP end of any host interfaced to it requires suspension of service to all the hosts directly connected to it.

In one case, the CCA host interface was unintentionally modified while work was being performed on the IMP to install another host interface; it was several days before the situation was properly diagnosed and repaired.

A. General Description of the Datacomputer

This appendix contains a brief general description of the structure of the Datacomputer which is intended to provide context for other parts of this report. Persons already familiar with the Datacomputer may skip over it. On the other hand, persons desiring an even more detailed internal description than presented here are referred to the final Semi-Annual Technical Report for the Datacomputer Project, contract number MDA903-74-C-0225, covering July through December 1976, and to the following two papers, which are available from CCA: Tertiary Memory Access and Performance in the Datacomputer (CCA-77-11), and Integrity and Recovery in the Datacomputer, a Machine for Very Large Databases (CCA-78-06).

It is intended that the direct, immediate user of the Datacomputer be a program running on an Arpanet host remote from the Datacomputer. This program may be acting as an intermediary for a person at a console, or it may be an automatically started background task that normally operates without human intervention, or it might be some other type of program. See Figure A.1.

Datacomputer User's View

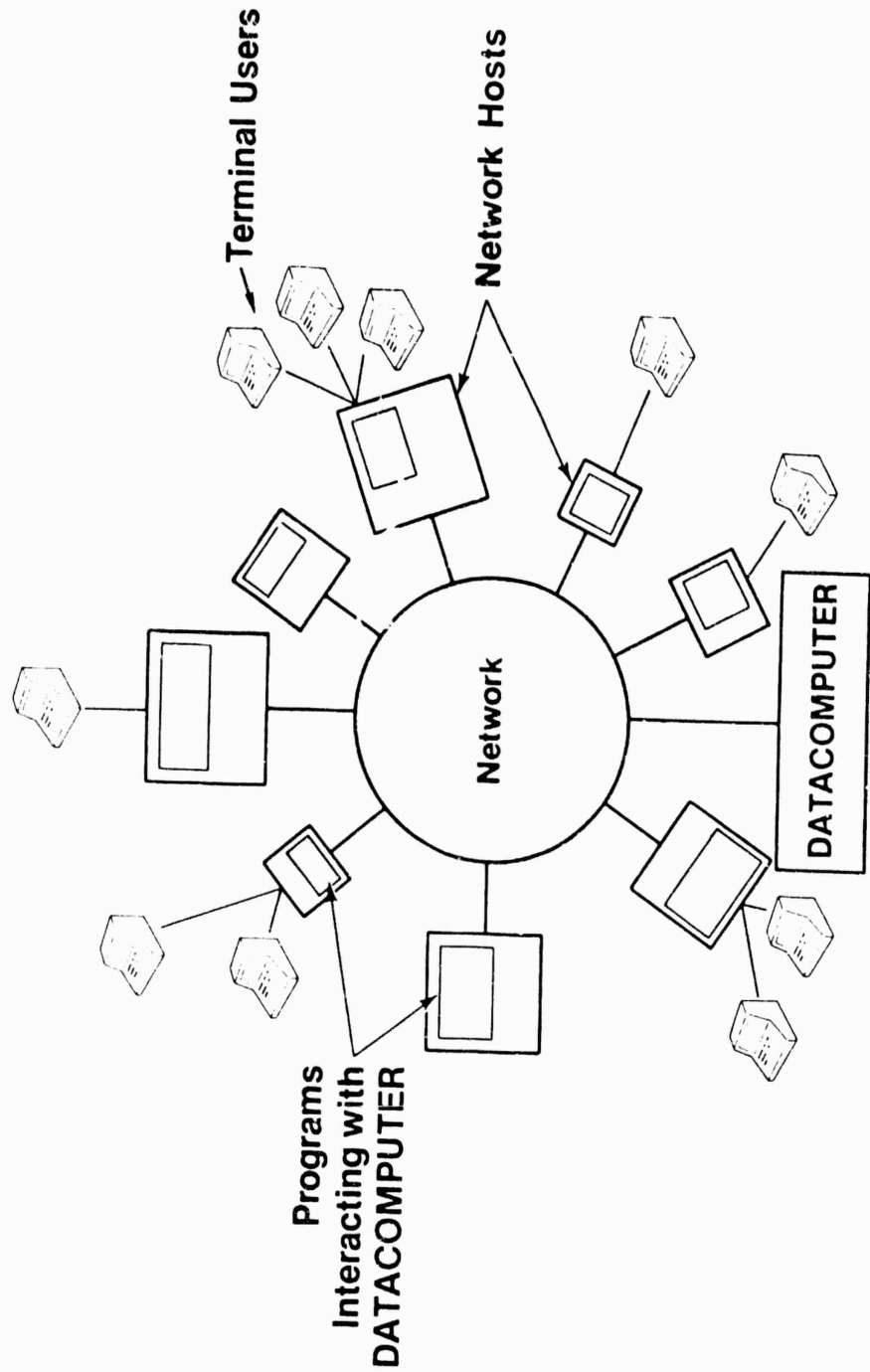

Such a remote program calls the Datacomputer over the network and establishes a pair of standard uni-directional 8-bit byte network connections. The program then proceeds to send Datalanguage over one connection while the Datacomputer replies on the other. Datalanguage is a uniform high level language which gives the user a hierarchically structured view of his data. It is described in the Datacomputer Version 5 User Manual which is available from CCA.

Actually, the Datacomputer sends a "reply" to prompt the user program whenever the Datacomputer is ready to accept another line of Datalanguage. Similarly, the Datacomputer keeps the user program abreast of the progress of its requests with various synchronization, error, and success messages and comments. All replies have a fixed format which is designed for easy parsing by the user program. The reply begins with a number quickly identifying certain important messages. This is followed by the date, time, and an internal Datacomputer identification of the message source. The remainder of a reply provides a human-readable version of the message to be conveyed.

In the case of serious errors, to assure resynchronization with the user program, the Datacomputer enters a special mode. In this resynchronization mode, it rejects all

messages from the user, giving an appropriate reply each time, until the user program sends a special message to clear the condition. This mechanism allows the user program to assure that commands sent after an unexpected error are not misinterpreted or partially ignored and partially executed.

Data as well as commands and replies can be transmitted between the user program and the Datacomputer over these initial 8-bit connections but certain characters are prohibited and the connections are fixed at their 8-bit bytesize. More general data transfers can be performed by making use of separate data connections.

The requests, replies, and data for a particular user program are handled by the half of the Datacomputer known as RH or the Request Handler. RH handles the parsing of the user commands, which are in Datalanguage, and the synthesis of replies. For more complex commands, RH takes the user's requests and the data descriptions stored in the Datacomputer and compiles them, in several stages, into code to execute the request.

Data descriptions in the Datacomputer are associated with each file of data. Data descriptions are also provided for data streams to be received from or transmitted into the Arpanet. These streams are known as ports.

Descriptions are set by the user when a file or port is created. Datacomputer data descriptions provide for hierarchical arrangements of structures of diverse data elements and repetitive lists. Many data types and data formatting alternatives are provided. This is important in ensuring that the Datacomputer can communicate efficiently with its diverse class of remote user computers.

RH accomplishes most of its activities by calling on routines in the other half of the Datacomputer, known as SV or services. SV is a pseudo-operating system in which RH runs. It is SV that actually has custody of the Datacomputer's multilevel hierarchical directory tree and enforces the extensive protection mechanisms of the system. SV is the part of the Datacomputer that ultimately communicates with storage devices and retrieves or stores bits. It views data as a relatively simple collection of areas subdivided into fixed size "pages" of data. All of the more sophisticated data description mechanism is in RH.

A special subpart of SV, called SDAX, moves active data from slower tertiary memory to faster secondary disk storage and moves it back when secondary storage is crowded. The CCA Datacomputer uses an Ampex TBM,

Software View of the Datacomputer

Figure A.2

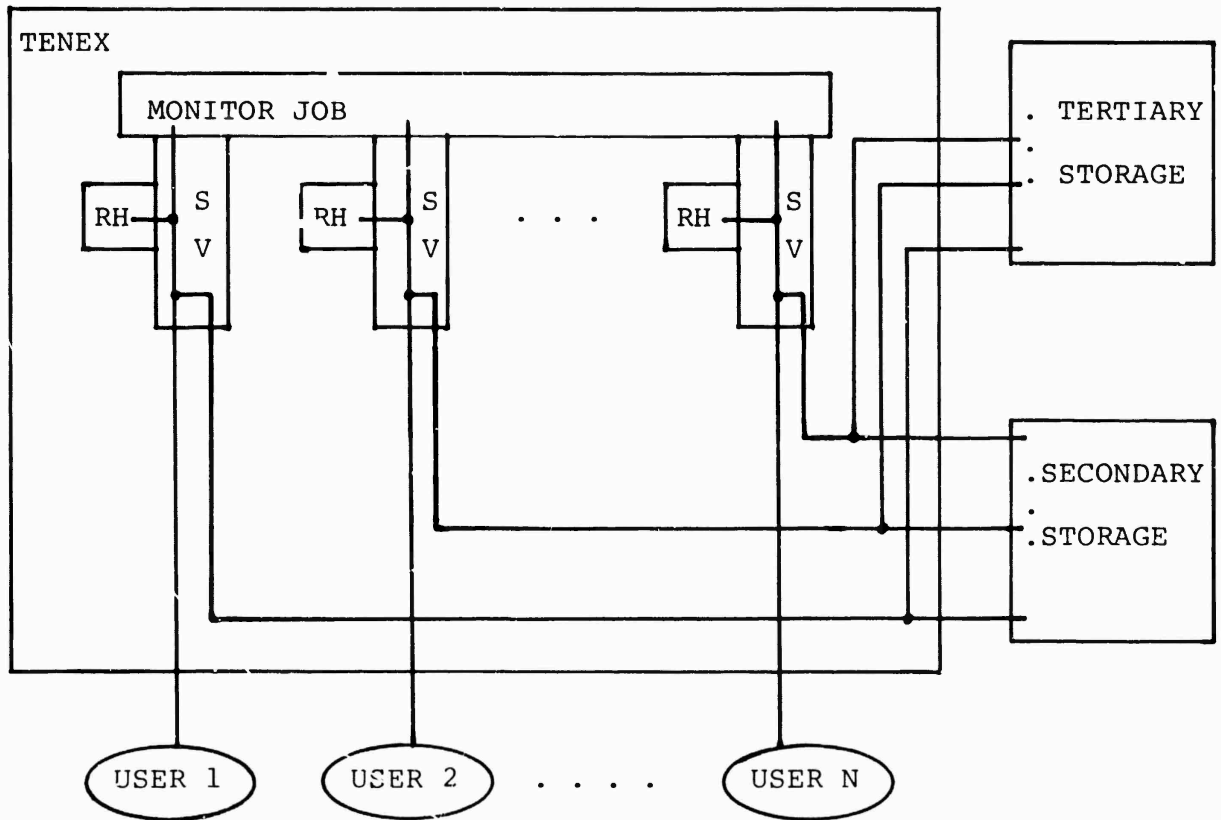

described in Section 6 above, for tertiary storage. SDAX keeps track of the location of the various copies of each file data page. It also ensures data consistency by preventing updates that are not successfully completed from affecting the original file. SDAX allows multiple readers and a single updater of a file among the Datacomputer subjobs. Each reader sees a consistent version of the file including only updates that were complete when they opened the file.

At any one time, there are multiple copies of the RH-SV pair serving users over the network. This actually means multiple copies of the joint variable area only, because they are implemented using reentrant code. The RH-SV pairs are called subjobs as they are all part of one job, under a monitor process, running in our modified TENEX operating system as shown in Figure A.2.

B. Developmental History

The developmental histories of the Datacomputer and SIP are reviewed in this appendix so as to put our current work in perspective. Persons familiar with this history may skip this material.

B.1 Datacomputer Development

Figures B.1 and B.2 give a quick overview of the contractual and developmental history of the Datacomputer. Since only the most important event of a quarter is given, a similar event may be overshadowed in a different quarter.

The initial "Network Data Handling System" contract starting in 1971 funded the initial conceptualization, design, and demonstration of the system. The installation of the PDP-10 and large secondary storage was included. The system developed in 1972 and 1973 used only disk storage but otherwise provided the same framework for shared remote use, on a simplified basis, as the present Datacomputer.

Datacomputer Development 1971-75

<u>Year</u>	<u>Qtr.</u>	"Network Data Handling System"	
1971	1	Concepts & Fundamental System Design	
71	2	Unicon Interface Designed	
71	3	Various Working Papers	
71	4	PDP-10 Delivered	
1972	1	PDP-10 Accepted	
72	2	TIP Installed	
72	3	Various Working Papers	
72	4		
1973	1	ICCC Demo	
73	2	DMCG 1st User	
73	3	0/9 Release	
73	4	0/9 Manual	"Datacomputer Support of Seismic Data Activity"
1974	1	0/9.7 Up	
74	2	0/10 Release	Contact Seismic Community
74	3	0/11 Work	SIP/Site Specified
74	4	0/11 Up	TBM Ordered
1975	1	V.1 Work	SIP Installed
75	2	V.1&XD Checkout	SIP on Net
75	3	V.1 Release	IMP/TIP Swap
75	4	File Groups Design	TBM Site Work
		:"Datacomputer"	

Datacomputer Development 1976-80

<u>Year</u>	<u>Qtr.</u>	"Datacomputer"	"Datacomputer Support of Seismic Data Activity"
1976	1	SDAX Testing	TBM Installed
76	2	TBM Interface	SIP Operational
76	3	File Groups Work	TBM Acceptance Test
76	4	V.2 Up with TBM	
1977	1	V.3 Up	
77	2	New CCP-SIP Protocol, Final TBM Acceptance	
77	3	V.4 Up	
77	4	V.5 Up	
1978	1	SWF Planning	
78	2	V.5 Manual Complete	
78	3	V.5 Manual Distributed	
78	4		"Enhancement of Datamodule 1"
1979	1		
79	2		
79	3	(Proposed)	
79	4		
1980	1		
80	2		
80	3		
80	4		

"Datacomputer & SIP Operations"



From 1974 through 1976, CCA held two contracts. The "Datacomputer" contract financed the transformation of the prototype framework Datacomputer into a highly useful data utility. Facilities of all sorts were added during these years including file security, tertiary memory support, accounting, expanded data description facilities including variable length containers and virtual containers, expanded data manipulation facilities including conditionals, blocks of requests with local variables, and, lastly, a number of critical efficiency improvements.

Meanwhile, the "Datacomputer Support of Seismic Data Activity" contract financed the SIP and TBM as described in the section below.

1977 was the first year of the combined "Datacomputer and SIP Operations" contracts. Primary concentration in 1977 was on operational improvements and user service. Many new users were contacted some of whom have become regular users. Final acceptance of the TBM did not occur until the second quarter of 1977 when various software changes within the TBM were delivered and verified.

B.2 SIP and TBM Development

The hardware configuration of the SIP was specified around the middle of 1974 at the time that the site modification at CCA to accommodate the SIP and the mass storage system was specified and the Ampex TBM mass storage system was ordered.

The SIP hardware was delivered in early 1975 and the SIP was connected to the Arpanet in June of 1975. The volume of seismic data to pass through the SIP and problems encountered in early tests indicated the necessity to upgrade the local Arpanet node at CCA. This was done in late 1975 when a model 316 TIP node was replaced with a model 516 IMP.

The SIP was fully operational and hundreds of hours of seismic data had been retransmitted to small test files in the Datacomputer by mid-1976. Further work was done in 1976 on improving the SIP's robustness in the face of hardware and communications troubles. Continuing problems with CCP<->SIP communications led to the design of a new communications protocol to be used on this link. Meanwhile, the TBM mass memory was accepted and integrated

with the Datacomputer and on October 1, 1976, the SIP-Datacomputer system became fully operational storing data into the mass storage system.

In the early parts of 1977, the new CCP<->SIP protocol [BBN] was implemented and the CCA local Arpanet node was further upgraded to a PLURIBUS IMP. These steps cleared up the previously chronic communications problems.

Since then, the SIP has been in virtually continuous operation, successfully receiving, buffering, reformatting, and forwarding seismic data.

References

[BBN]

BBN Report No. 3460, "VELANET Communication Protocols between the CCP and the SIP and between the CCP and the DP", 5 April 1977.

[CCA]

Computer Corporation of America, Datacomputer Version 5 User Manual, Cambridge, Massachusetts, July 1978.

[DORIN & EASTLAKE]

R. H. Dorin and Donald E. Eastlake, III; "Use of the Datacomputer in the Vela Seismological Network"; Technical Report No. CCA-77-08, Computer Corporation of America, 575 Technology Square, Cambridge, Massachusetts, 02139, April 15, 1977.

[DORIN & SATTLEY]

Dorin, R.H. and Sattley, J.Z. Very Large Databases: Final Technical Report, Technical Report No. CCA-77-10, Computer Corporation of America, 575 Technology Square, Cambridge, Massachusetts, 02139, August 30, 1977.

[EASTLAKE a]

Eastlake, III, D.E. "Tertiary Memory Access and Performance in the Datacomputer", Technical Report No. CCA-77-11, Computer Corporation of America, 575 Technology Square, Cambridge, Massachusetts, 02139, June 30, 1977.

[EASTLAKE b]

Eastlake, III, D.E., "SIP Accomodation of Additional Seismic Data Sites", 29 January 1979, Technical Report CCA-79-08, Computer Corporation of America, 575 Technology Square, Cambridge, Massachusetts 02139.

[EASTLAKE & SATTLEY a]

Eastlake, III, D.E., and Sattley, J.Z., "Program Design for SWF-D: The Signal Waveform File Demon", 30 June 1978, Technical Report CCA-78-10A, Computer Corporation of America, 575 Technology Square, Cambridge, Massachusetts 02139.

[EASTLAKE & SATTLEY b]

Eastlake, D.E., III and Sattley, J.Z., "Assistance in the Design of the SWF System", January 30, 1979, CCA-79-13, Computer Corporation of America, 575 Technology Square, Cambridge, Massachusetts 02139.

[LINCOLN]

ESD-TR-78-64 Semiannual Technical Summary, Seismic Discrimination, 31 March 1978, Lincoln Laboratory, Massachusetts Institute of Technology, Lexington, Massachusetts 02173.

[MARILL & STERN]

Marill, Thomas; and Stern, D.H. "The Datacomputer: A Network Data Utility", Proceedings AFIPS National Computer Conference, AFIPS Press, Vol. 44, 1975.

[SATTLEY a]

Joanne Z. Sattley, "Report on the Implementation and Test of SWF-D: The Signal Waveform File Demon", Technical Report CCA-79-09, 31 January 1979, Computer Corporation of America, 575 Technology Square, Cambridge, Massachusetts 02139.

[SATTLEY b]

Joanne Z. Sattley, "Program Listings for SWF-D: The Signal Waveform File Demon", Technical Report CCA-79-10, 31 January 1979, Computer Corporation of America, 575 Technology Square, Cambridge, Massachusetts 02139.

[SATTLEY c]

Joanne Z. Sattley, "MARS - A Message Archiving and Retrieval Service", 8 January 1978, ARPA Network Working Group Request for Comments #744, Network Information Center #42857.

[TELEDYNE]

VELANET ESF/SWF PROCESSING, Joseph Greenhalgh, Design Draft, February 1, 1978, Teledyne Geotech, Alexandria Laboratories, P. O. Box 334, Alexandria, Virginia 22313.