

AD-A068 611

SCRIPPS INSTITUTION OF OCEANOGRAPHY LA JOLLA CA VISA--ETC F/G 20/6  
AIRBORNE MEASUREMENTS OF ATMOSPHERIC VOLUME SCATTERING COEFFICI--ETC(U)  
JUN 78 S O DUNTLEY, R W JOHNSON, J I GORDON F19628-76-C-0004  
SIO-REF-78-28 AFOL-TR-78-0168 NL

UNCLASSIFIED

1 of 2  
AD A068611  
Microfilm



AFGL-TR-78-0168

**LEVEL**

②  
B-5

SIO Ref. 78-28

# Airborne Measurements Of Atmospheric Volume Scattering Coefficients In Northern Europe, Summer, 1977

Seibert Q. Duntley  
Richard W. Johnson  
Jacqueline I. Gordon

DDC  
REFINED  
MAY 15 1979  
RECEIVED

Approved for public release; distribution unlimited.

Scientific Report No. 9  
June 1978

Contract No. F19628-76-C-0004  
Project No. 7621  
Task No. 7621-11  
Work Unit No. 7621-11-01

Contract Monitor, Major T. S. Cross, USAF  
Optical Physics Laboratory

Prepared for  
Air Force Geophysics Laboratory, Air Force Systems Command  
United States Air Force, Bedford, Massachusetts 01730

QUALITY LABORATORY La Jolla, California 92033

79 05 14 023

AD A068611

DUU ILL UUI

Qualified requestors may obtain additional copies from the Defense Documentation Center. All others should apply to the National Technical Information Service.



UNCLASSIFIED

SECURITY CLASSIFICATION OF THIS PAGE (When Data Entered)

20. ABSTRACT continued:

as follows: Three narrow band optical filters with mean wavelengths of 478, 664, and 765 nanometers; and one broad band sensitivity representing a pseudo-photopic response with a mean wavelength of 557 nanometers.

Selected meteorological properties, measured concurrently with the radiometric data are also included.



ACCESSION for

NTIS White Section

DDC Buff Section

UNANNOUNCED

JUSTIFICATION

BY

DISTRIBUTION/AVAILABILITY CODES

Dist.	AvAIL	SPECIAL
A		

UNCLASSIFIED

SECURITY CLASSIFICATION OF THIS PAGE (When Data Entered)

AFGL-TR-78-0168

SIO Ref. 78-28

**AIRBORNE MEASUREMENTS OF ATMOSPHERIC VOLUME SCATTERING  
COEFFICIENTS IN NORTHERN EUROPE, SUMMER, 1977**

Seibert Q. Duntley, Richard W. Johnson, and Jacqueline I. Gordon

Visibility Laboratory  
University of California, San Diego  
Scripps Institution of Oceanography  
La Jolla, California 92093

Approved:

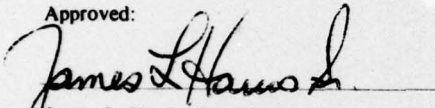
  
James L. Harris, Sr., Director  
Visibility Laboratory

Approved:

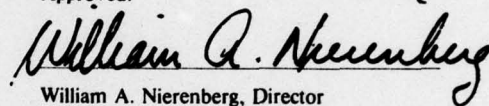
  
William A. Nierenberg, Director  
Scripps Institution of Oceanography

**CONTRACT NO. F19628-76-C-0004**

**Project No. 7621**

**Task No. 7621-11**

**Work Unit No. 7621-11-01**

**Scientific Report No. 9**

**June 1978**

**Contract Monitor**

**Major Ted S. Cress, Atmospheric Optics Branch, Optical Physics Division**

Approved for public release; distribution unlimited.

Prepared for  
AIR FORCE GEOPHYSICS LABORATORY  
AIR FORCE SYSTEMS COMMAND  
UNITED STATES AIR FORCE  
HANSCOM AFB, MASSACHUSETTS 01731

## SUMMARY

This report, which describes portions of the Visibility Laboratory's Project OPAQUE III\* effort, was prepared under AFGL Contract F19628-76-C-0004. The principal project task was to take daytime atmospheric optical measurements in northern Europe and, from these measurements, to determine optical properties for various upward- and downward-inclined paths of sight. These properties include the natural irradiance upon horizontal plane surfaces, scalar irradiances, total volume scattering coefficients, atmospheric beam transmittances, path radiances, directional path reflectances, and directional sky and terrain reflectances. This report does not contain all of these optical properties, but in an effort to accelerate the availability of selected values, we have restricted the data to total volume scattering coefficients, atmospheric beam transmittances, and natural irradiances upon horizontal plane surfaces. The data base for the derivation of the additional, more directional optical properties is available on tape and can be exploited upon demand. Selected meteorological properties measured concurrently with the radiometric data are also included.

The OPAQUE III field trip was made to northern Europe during July and August 1977. Data were recorded in three separate geographical regions - namely, off the southern coast of Denmark, over northern Germany, and over western France. The daytime flight conditions for the 12 flights reported herein ranged from scattered clouds at low altitude and clear at high altitude to fully overcast.

The airborne radiometric instrumentation, developed at the Visibility Laboratory and mounted in Air Force C-130A Aircraft No. 50022, consisted of a total scattering meter (or integrating nephelometer) for determining the total volume scattering coefficient, two sky scanning radiometers for measuring upper and lower hemisphere (sky and terrain) radiances, a dual irradiator for measuring alternately the downwelling and upwelling irradiances, an equilibrium radiance telephotometer, and a variable direction path function meter. The meteorological instrumentation included an absolute pressure transducer, a dewpoint hygrometer, and an AN/AMQ-17 aerograph for measuring ambient temperature and pressure.

A Visibility Laboratory ground based data station, equipped with a contrast reduction meter for determining earth-to-space beam transmittance and an integrating nephelometer for determining the ground level total volume scattering coefficient, was operational at two of the three data sites. It was located at the Meppen OPAQUE site while the aircraft was operating in northern Germany, and at the Bruz OPAQUE site while the aircraft was in western France.

Each optical instrument was fitted with five optical filters causing it to measure at three narrow wavelength bands of the spectrum and two broad pass bands. The measurements were made using three narrow band filters at mean wavelengths of 478, 664, and 765 nanometers and a pseudo-photopic filter with a mean wavelength of 557 nanometers.

All primary data were recorded on magnetic tapes which were returned to the Visibility Laboratory for processing at the computer facilities of the University of California, San Diego.

\*The project title OPAQUE III has been assigned to this activity by the Air Force Geophysics Laboratory as a nickname for procedural identification only. It is not necessarily utilized or recognized by agencies or organizations outside of the participating USAF organizations and the Visibility Laboratory. The relationship between this activity and other similar activities conducted by the Visibility Laboratory is well-illustrated in AFCL-TR-0457. Duntley, *et al.* (1975b).

# TABLE OF CONTENTS

SUMMARY .....	v
LIST OF ILLUSTRATIONS .....	ix
RELATED CONTRACTS AND PUBLICATIONS .....	xi
GLOSSARY AND NOTATION .....	xiii
1. INTRODUCTION .....	1-1
2. THEORY AND COMPUTATIONAL PROCEDURES .....	2-1
3. INSTRUMENTATION .....	3-1
3.1 Radiometric Systems .....	3-1
3.2 Meteorological Systems .....	3-5
3.3 Control and Communication Systems .....	3-5
3.4 Photographic Systems .....	3-5
3.5 Radiometric Calibration Procedures .....	3-6
3.6 Standard Response Characteristics for Broad Band Sensors .....	3-7
4. DATA COLLECTION METHODS .....	4-1
4.1 Airborne System .....	4-1
4.2 Ground-Bases System .....	4-4
5. DATA PROCESSING .....	5-1
5.1 Airborne Data .....	5-1
5.2 Ground-Based Data .....	5-4
5.3 Calibration Data .....	5-4
5.4 Data Tapes .....	5-4
6. WEATHER SUMMARY .....	6-1
6.1 Introduction and Graphics .....	6-1
6.2 Synoptic Conditions .....	6-12
6.3 Tabular Summary and Glossary .....	6-15
7. DATA PRESENTATION .....	7-1
7.1 Airborne Data and Flight Summary .....	7-1
7.2 Description of Airborne Data Tables and Graphs .....	7-7
7.3 Presentation of Airborne Data .....	7-9
8. DATA INTERPRETATION AND EVALUATION .....	8-1
8.1 Meteorological Data .....	8-1
8.2 Airborne Radiometric Data .....	8-4
8.3 Summary .....	8-25
9. ACKNOWLEDGEMENTS .....	9-1
10. REFERENCES .....	10-1

## LIST OF ILLUSTRATIONS

Figure		Page
1-1a	Typical OPAQUE III Flight Tracks	1-2
1-1b	Typical OPAQUE III Data Sites, Detail Maps. Latitude and Longitude References are to Flight Track Center Point	1-2
1-1c	Typical OPAQUE III Data Sites, Detail Maps. Latitude and Longitude References are to Flight Track Center Point	1-3
1-1d	Typical OPAQUE III Data Sites, Detail Maps. Latitude and Longitude References are to Flight Track Center Point	1-3
1-2	Standard Spectral Responses - Project OPAQUE III	1-4
2-1	Path Length Geometry for Steeply Inclined Paths of Sight	2-2
3-1	C-130 Airborne Instrument System	3-2
3-2	Ground-Based Instrument System	3-2
3-3	Artist's Rendition of Modified Integrating Nephelometer	3-3
3-4	Typical Absolute Calibration Form	3-6
4-1	Typical Visibility Laboratory Flight Profile	4-2
5-1	Atmospheric Visibility Program Airborne Data Processing Schedule	5-2
5-2	Atmospheric Visibility Program Ground Data Processing Schedule	5-3
6-1	Synoptic Charts of European Area During Project OPAQUE III	6-3 6-4 6-5
6-2	Temperature Versus Altitude for Twelve Project OPAQUE III Flights	6-6 6-7 6-8
6-3	Relative Humidity Versus Altitude for Twelve Project OPAQUE III Flights	6-9 6-10 6-11
6-4	Portions of Satellite Maps for Project OPAQUE III	6-22 6-23
7-1	Typical Sky and Terrain Photographs for Flights C-410 and C-412	7-4
7-2	Typical Sky and Terrain Photographs for Flights C-415 and C-416	7-5
8-1	Temperature for OPAQUE III Flights From 4 to 29 July 1977 Latitudes 48.02°N to 54.68°N Compared to Temperature From U.S. Standard Atmosphere Supplements (1966).	8-3
8-2	Temperature for OPAQUE III Flights From 1 to 11 August 1977, Latitude 52.88°N to 54.68°N Compared to Temperature from U.S. Standard Atmosphere Supplements (1966).	8-4
8-3	Measured Proportional Volume Scattering Function Versus the Ratio of Total to Rayleigh Volume Scattering Coefficient for OPAQUE III Pseudo-photopic Filter 4 Mean Wavelength 557 Nanometers	8-5
8-4	Total Volume Scattering Coefficient Versus Volume Scattering Function at 30 Degrees for OPAQUE III Filter 4 Pseudo-Photopic Mean Wavelength 557 Nanometers, $C = 2.37 \times 10^{-5}$	8-6

8-5	Total Volume Scattering Coefficient for Filter 4 Pseudo-Photopic for Six OPAQUE III Flights, 4 through 29 July 1977.	8-8
8-6	Total Volume Scattering Coefficient for Filter 4 Pseudo-Photopic for Six OPAQUE III Flights, 1 through 11 August 1977.	8-9
8-7	Low Altitude Total Volume Scattering Coefficients for Type I and II Profiles	8-11
8-8	Low Altitude Total Volume Scattering Coefficients for Type II and Type III Profiles	8-12
8-9	Low Altitude Total Volume Scattering Coefficients for Type III Profiles	8-13
8-10	Comparison of the Photopic Scattering Coefficient and Relative Humidity Profiles as Measured During Flights C-411, C-412, C-415, and C-420.	8-16
8-11	Ratio of Total to Rayleigh Total Volume Scattering Coefficient as a Function of Relative Humidity for Flights C-411, C-412, C-415, and C-420.	8-18
8-12	Project OPAQUE III Low Altitude Downwelling Irradiance for Filter 4 Pseudo-Photopic Compared to Brown (1952)	8-21
8-13	Downwelling Irradiance for Filter 4 Pseudo-Photopic for Six OPAQUE III Flights, 4 through 29 July 1977.	8-22
8-14	Downwelling Irradiance for Filter 4 Pseudo-Photopic for Six OPAQUE III Flights, 1 through 11 August 1977.	8-23

## RELATED CONTRACTS AND PUBLICATIONS

Related Contracts: None

Publications:

Duntley, S. Q., R. W. Johnson, and J. I. Gordon, "Airborne Measurements of Optical Atmospheric Properties in Southern Germany," AFCRL-72-0255, SIO Ref. 72-64 (July 1972).

Duntley, S. Q., R. W. Johnson, and J. I. Gordon, "Airborne and Ground-Based Measurements of Optical Atmospheric Properties in Central New Mexico," AFCRL-72-0461, SIO Ref. 72-71 (September 1972).

Duntley, S. Q., R. W. Johnson, and J. I. Gordon, "Airborne Measurements of Optical Atmospheric Properties, Summary and Review," AFCRL-72-0593, SIO Ref. 72-82 (November 1972).

Duntley, S. Q., R. W. Johnson, and J. I. Gordon, "Airborne Measurements of Optical Atmospheric Properties in Southern Illinois," AFCRL-TR-73-0422, SIO Ref. 73-24 (July 1973).

Duntley, S. Q., R. W. Johnson, and J. I. Gordon, "Airborne and Ground-Based Measurements of Optical Atmospheric Properties in Southern Illinois," AFCRL-TR-74-0298, SIO Ref. 74-25 (June 1974).

Duntley, S. Q., R. W. Johnson, and J. I. Gordon, "Airborne Measurements of Optical Atmospheric Properties in Western Washington," AFCRL-TR-75-0414, SIO Ref. 75-24 (September 1975).

Duntley, S. Q., R. W. Johnson, and J. I. Gordon, "Airborne Measurements of Optical Atmospheric Properties, Summary and Review II," AFCRL-TR-75-0457, SIO Ref. 75-26 (September 1975).

Duntley, S. Q., R. W. Johnson, and J. I. Gordon, "Airborne Measurements of Optical Atmospheric Properties in Northern Germany," AFGL-TR-76-0188, SIO Ref. 76-17 (September 1976).

Duntley, S. Q., R. W. Johnson, and J. I. Gordon, "Airborne Measurements of Atmospheric Volume Scattering Coefficients in Northern Europe, Spring 1976," AFGL-TR-77-0078, SIO Ref. 77-8 (March 1977).

Duntley, S. Q., R. W. Johnson, and J. I. Gordon, "Airborne Measurements of Atmospheric Volume Scattering Coefficients in Northern Europe, Fall 1976," AFGL-TR-77-0239, SIO Ref. 78-3 (January 1978).

Gordon, J. I., J. L. Harris, Sr., and S. Q. Duntley, "Measuring Earth-to-Space Contrast Transmittance from Ground Stations," *Appl. Opt.* **12**, 1317-1324 (1973).

Gordon, J. I., C. F. Edgerton, and S. Q. Duntley, "Signal-Light Nomogram," *J. Opt. Soc. Am.* **65**, 111-118 (1975).

## GLOSSARY AND NOTATION

The notation used in reports and journal articles produced by the Visibility Laboratory staff follows, in general, the rules set forth in pages 499 and 500, Duntley *et al.* (1957). These rules are:

Each optical property is indicated by a basic (parent) symbol.

A presubscript may be used with the parent symbol as an identifier, e.g., *b* indicates background while *t* denotes an object.

A postsubscript may be used to indicate the length of a path of sight, e.g., *r* denotes an *apparent* property as measured at the end of a path of sight of length *r*, while *o* denotes an *inherent* property based on the hypothetical concept of a photometer located at zero distance from an object.

A postsuperscript\* or postsubscript\*, is employed as a mnemonic symbol signifying that the radiometric quantity has been generated by the scattering of ambient light reaching the path from all directions.

The parenthetical attachments to the parent symbol denote altitude and direction. The letter *z* indicates altitude in general; *z<sub>i</sub>* is used to specify the altitude of an object. The direction of a path of sight is specified by the zenith angle  $\theta$  and the azimuth  $\phi$ . In the case of irradiances, the downwelling irradiance is designated by *d*, the upwelling by *u*.

The glossary for meteorological symbols is presented in Section 6.

*A(z)* Albedo at altitude *z*, defined by the equation  $A(z) \equiv H(z,u)/H(z,d)$ .

AGL Above ground level.

*H(z,d)* Irradiance produced by downwelling flux as determined on a horizontal flat plate at altitude *z*. In this report *d* is used in place of the minus sign in the notation  $H(z,-)$  which appears in Duntley (1969). This property may be defined by the equation

$$H(z,d) \equiv \int_{2\pi} N(z,\theta',\phi') \cos\theta' d\Omega'$$

*H(z,u)* Irradiance produced by the upwelling flux as determined on a horizontal flat plane at altitude *z*. Here *u* is substituted for the plus sign formerly used in the notation  $H(z,+)$ .

$L(z)$  Attenuation length at altitude  $z$ . This property is the reciprocal of the attenuation coefficient, that is,

$$L(z) \equiv \alpha(z)^{-1}.$$

$\bar{L}(z)$  Equivalent attenuation length is defined as

$$\bar{L}(z) = \frac{-z}{\ln T_z(0,0)}.$$

$N(z, \theta, \phi)$  Radiance as determined from altitude  $z$  in the direction specified by zenith angle  $\theta$  and azimuth  $\phi$ .

${}_sP(t)$  Saturated vapor pressure at ambient temperature.

${}_sP(d,t)$  Saturated vapor pressure at dewpoint or frostpoint temperature.

$RH$  Relative humidity in percent  $RH = [{}_sP(d,t)/{}_sP(t)] 100$ .

$R/M(0)$  Universal gas constant.

$\overline{S_\lambda T_\lambda}$  Standardized relative spectral response of filter/cathode combination where  $S_\lambda$  is spectral sensitivity of the multiplier phototube cathode and  $T_\lambda$  is spectral transmittance of optical filter.

$s(z)$  Total volume scattering coefficient as determined at altitude  $z$ . This property may be defined by the equation

$$s(z) \equiv \int_{4\pi} \sigma(z, \beta) d\Omega$$

In the absence of atmospheric absorption, the total volume scattering coefficient is numerically equal to the attenuation coefficient.

${}_R s(z)$  Total volume scattering coefficient for Rayleigh scattering at altitude  $z$ .

$t$  Ambient temperature °C.

$d,t$  Dewpoint or frostpoint temperature, °C.

$T_r(z, \theta)$  Beam Transmittance as determined at altitude  $z$  for a path of sight of length  $r$  at zenith angle  $\theta$ . This property is independent of azimuth in atmospheres having horizontal uniformity. It is always the same for the designated path of sight or its reciprocal.

$VV$  Visibility as estimated by the meteorologists  $VV = 3/s(z)$ .

$z$  Altitude, usually used as above ground level.

$z_i$	Altitude of an object.
$\alpha(z)$	Volume attenuation coefficient as determined at altitude $z$ . In the absence of atmospheric absorption, the attenuation coefficient is numerically equal to the volume scattering coefficient.
$\beta$	Symbol for scattering angle of flux from a light source. It is equal to the angle between the line from the source to the observer and the path of sight.
$\Delta$	Symbol to indicate incremental quantity and used with $r$ and $z$ to indicate small, discrete increments in path length $r$ and altitude $z$ .
$\delta_\lambda$	Response area is defined as $\delta_\lambda = \sum (\overline{S_\lambda T_\lambda}) \Delta\lambda$ .
$\theta$	Symbol for zenith angle. This symbol is usually used as one of two coordinates to specify the direction of a path of sight.
$\theta'$	Symbol for zenith angle usually used as one of two coordinates to specify the direction of a discrete portion of the sky.
$\lambda$	Symbol for wavelength.
$\bar{\lambda}$	Mean wavelength is defined as $\bar{\lambda} \equiv \sum \lambda (\overline{S_\lambda T_\lambda}) \Delta\lambda / \delta_\lambda$
$\rho(z)$	Density at altitude $z$ .
$\sigma$	Symbol for volume scattering function. Parenthetical symbols may be added; for example, $\beta$ may be used to designate the scattering angle from a source. In Gordon (1969) the parenthetical symbols are $z$ and $\beta$ for altitude and scattering angle.
$\sigma(z, \beta) / s(z)$	Proportional directional volume scattering function. This may be defined by the equation $\int_{4\pi} [\sigma(z, \beta) / s(z)] d\Omega \equiv 1.$
$\phi$	Symbol for azimuth. The azimuth is the angle in the horizontal plane of the observer between a fixed point and the path of sight. The fixed point may be, for example, true north, the bearing of the sun, or the bearing of the moon. This symbol is usually used as one of two coordinates to specify the direction of a path of sight.
$\phi'$	This symbol for azimuth is usually used as one of two coordinates to specify the direction of a discrete portion of the sky.
$\Omega$	Symbol for solid angle.

For a hemisphere:  $\Omega = 2\pi$  steradians;

For a sphere:  $\Omega = 4\pi$  steradians.

Faint, illegible text, possibly bleed-through from the reverse side of the page. The text is arranged in several paragraphs and appears to be a formal document or report. The content is mostly obscured by the low contrast and grain of the scan.

# 1. INTRODUCTION

The field measurement program described in this report was organized under the project title OPAQUE III (Optical Atmospheric Quantities in Europe). It was conducted during July and August 1977, to obtain data for case studies of the summer atmospheric optical properties over northern Europe.

The OPAQUE III deployment was the third in a series that is planned to provide atmospheric optical data in several regions of northern Europe. These deployments are organized as a cooperative but independent effort associated with the NATO Research Study Group 8 of Panel IV, AC243. The OPAQUE III deployment plan was specified in Air Force Geophysics Laboratory OPLAN for OPAQUE III dated 10 April 1977.

The Visibility Laboratory maintains a continuing program of improved techniques for predicting, by calculation from physical data, the probabilities that any object can be visually detected and recognized. The program is multifaceted in that it involves the development of techniques and expertise in several different technical areas, each related to the visual detection and recognition task. Several of the major areas are, for example, measurement and analysis of typical terrain characteristics and scene reflectances, studies in the restoration of atmospherically distorted images, measurement and analysis of the optical properties of the atmosphere, and studies into the perceptual capabilities of the human visual system and its electro-optical counterparts. The joint application of the techniques perfected in each of these specialty areas result in the determination of detection probabilities. Inclusion of allowances for *a priori* information and reasoning processes of the brain enable the probabilities of recognition, classification, and identification of real-world objects to be predicted.

The instrumental and computational organization for implementing the continuing improvement of those techniques related to the documentation of optical atmospheric properties is documented in several preceding reports. A recent example of these reports is AFGL-TR-76-0188, Duntley, *et al.* (1976).

This report, Scientific Report No. 9, has been prepared under Contract No. F19628-76-C-0004. It contains measured profiles of atmospheric volume scattering coefficient and downwelling irradiances between ground level and altitudes up to 6 kilometers. Computed values for vertical atmospheric beam transmittance and equivalent attenuation length are also presented for the same altitude interval. The measurements were made along the flight tracks illustrated in Figs. 1-1a, 1-1b, 1-1c, and 1-1d. Selected meteorological properties measured concurrently with the radiometric data are also included.

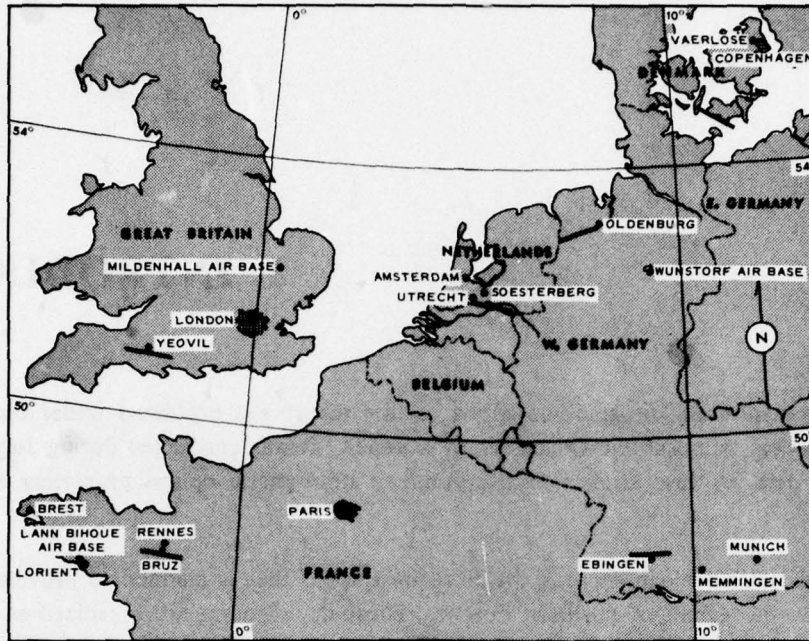

Fig. 1-1a. Typical OPAQUE III Flight Tracks.

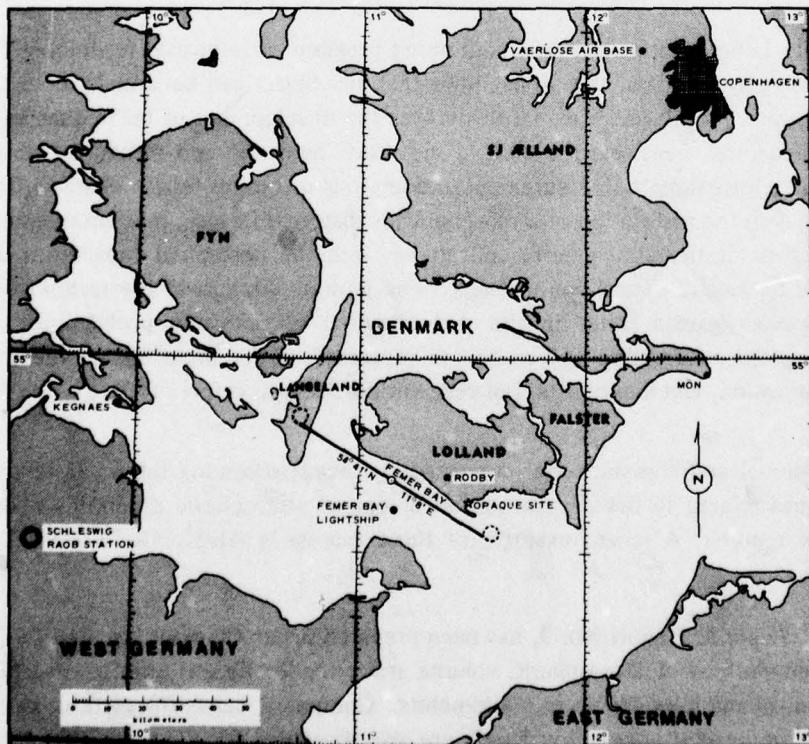

Fig. 1-1b. Typical OPAQUE III Data Sites, Detail Maps. Latitude and Longitude References are to Flight Track Center Point.

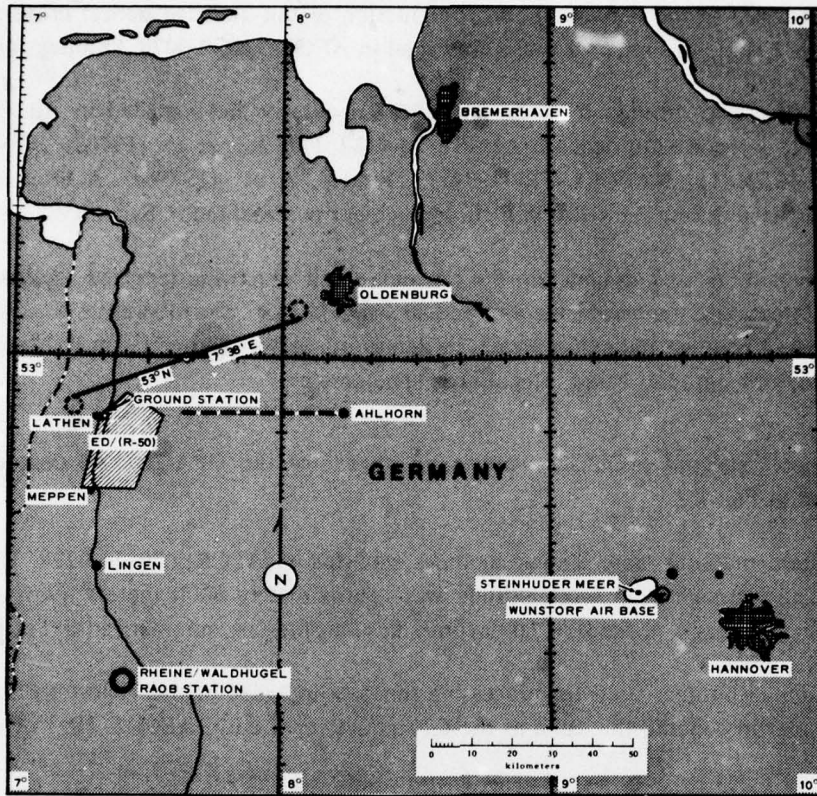

Fig. 1-1c. Typical OPAQUE III Data Sites, Detail Maps. Latitude and Longitude References are to Flight Track Center Point.

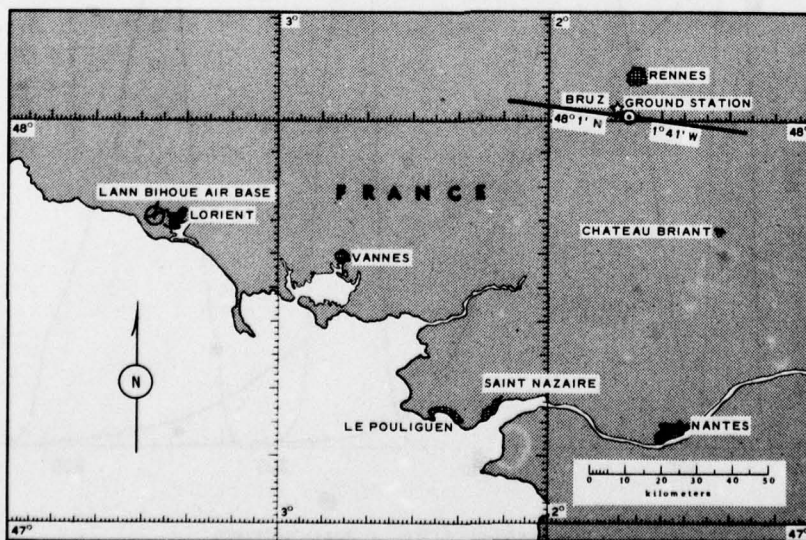

Fig. 1-1d. Typical OPAQUE III Data Sites, Detail Maps. Latitude and Longitude References are to Flight Track Center Point.

The methods used in the derivation and computation of the included optical properties are summarized in Section 2, and are similar to those presented in AFGL-TR-77-0078, Duntley, *et al.* (1977).

The instrumentation, developed at the Visibility Laboratory and installed in Air Force C-130A Aircraft No. 50022, is reported in detail in AFCRL-70-0137, Duntley, *et al.* (1970a), AFCRL-72-0593, Duntley, *et al.* (1972c), and AFCRL-TR-75-0457, Duntley, *et al.* (1975b). A brief review of the instrumentation as used during the OPAQUE III deployment is presented in Section 3.

The instrumentation used to generate the raw data upon which the reported properties are based consisted of an integrating nephelometer and a dual irradiator. Corroborative data were obtained using a ground-based contrast reduction meter, to determine earth-to-space beam transmittances when weather permitted, and a ground based integrating nephelometer.

The radiometer spectral responses were standardized for the OPAQUE III deployment in the manner illustrated in Fig. 1-2.

Data collection methods were similar to those reported in AFCRL-TR-74-0298, Duntley, *et al.* (1974). The highest straight and level altitude was approximately 6000 meters above ground level (AGL). The basic features of these stylized daytime flight profiles are summarized in Section 4.

The computer techniques used for processing the data included in this report are summarized in Section 5. They are, in general, the same as the techniques reported in AFCRL-TR-75-0457, Duntley, *et al.* (1975b).

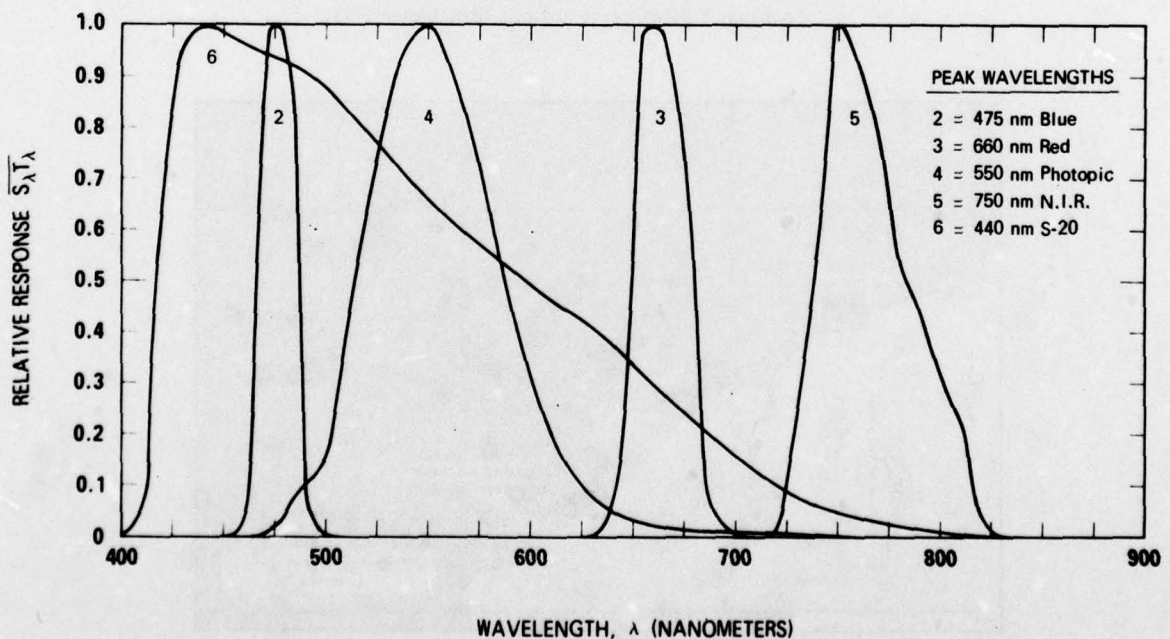

Fig. 1-2. Standard Spectral Responses - Project OPAQUE III.

A general discussion of the weather patterns that predominated in the northern European area during the data collection interval is presented in Section 6. This section, in conjunction with the flight track photographs shown in Section 7, is intended as an aid to the data user's generalized interpretation and evaluation. The inclusion of the graphical presentations is intended to further facilitate the user's rapid orientation with the overall weather situation.

The radiometric data representing 12 separate flights are also presented in Section 7. The presentation format is similar to that used in AFCRL-TR-77-0078, Duntley, *et al.* (1977) since only scattering coefficient and irradiance data are included.

Discussion related to the interpretation and evaluation of the data collected is found in Section 8.

## 2. THEORY AND COMPUTATIONS

The underlying theoretical concepts and the subsequent computational procedures upon which the Visibility Laboratory bases its determination of contrast transmission through the troposphere are well documented in our preceding reports. AFGL-TR-76-0188, "Airborne Measurements of Optical Atmospheric Properties in Northern Germany," Duntley, *et al.* (1976) is an appropriate reference and contains a substantial set of sample applications and references.

The format included in the following paragraphs has been extracted from the more complete description contained in the reference above. It is designed to support only the selected data appearing in Section 7 herein, and is not complete enough to develop contrast transmittance or any of the other more directional atmospheric optical properties normally associated with the reports in this series.

### TOTAL VOLUME SCATTERING COEFFICIENT

A direct measure of air clarity is the atmospheric attenuation coefficient  $\alpha(z)$ . The parenthetical modifier indicates the altitude  $z$ . The attenuation coefficient is the sum of the total volume scattering coefficient and the absorption coefficient. If there is no absorption, the attenuation coefficient is numerically equal to the total volume scattering coefficient  $s(z)$ .

The total volume scattering coefficient may be defined by the equation

$$s(z) \equiv \int_{4\pi} \sigma(z, \beta) d\Omega, \quad (2.1)$$

where  $\sigma(z, \beta)$  is the volume scattering function at altitude  $z$  and scattering angle  $\beta$ . The integrating nephelometer used to make the total volume scattering coefficient measurements performs the integral in Eq. 2.1 optically. It utilizes a parallel light beam and a cosine-law collector viewing the scattered flux. The instrument is similar in principle to one of four instruments for measuring total volume scattering coefficient described by Beuttell and Brewer (1949).

### BEAM TRANSMITTANCE

The beam transmittance  $T_r(z, \theta)$  at altitude  $z$ , zenith angle  $\theta$ , and over path length  $r$  is obtained directly from the total scattering coefficient  $s(z)$  by means of Eq. 2.2. (Refer also to Boileau (1964), p. 570.) When there is no significant atmospheric absorption in the passbands of the measurements, e.g.,

from smoke, dust or smog, the attenuation coefficient  $\alpha(z)$  is equivalent to the total volume scattering coefficient  $s(z)$ . Therefore

$$T_r(z, \theta) = \exp \left[ -\sum_{i=1}^n \alpha(z_i) \Delta r \right] = \exp \left[ -\sum_{i=1}^n s(z_i) \Delta r \right], \quad (2.2)$$

where  $\Delta r$  is the incremental path length. The summations are made using the trapezoidal rule. The measured total volume scattering coefficient data are extrapolated to ground level when no ground-based measurements are available. The extrapolation assumes that the scattering particles are the same at all altitudes, but decrease or increase according to the density at each altitude  $\rho(z)$ :

$$s(0) = \frac{s(z)\rho(0)}{\rho(z)}. \quad (2.3)$$

Similarly, upward extrapolations are made to the highest reported altitude above ground level when the highest flight altitude is less. Extrapolation in this case is based on the scattering coefficient measured at the highest flight altitude. The densities used for the extrapolations are based upon the U.S. Standard Atmosphere (1962). The density at each altitude is obtained by truncated Chebyshev Expansion using the coefficients for the atmosphere between 0 and 80 kilometers [U.S. Standard Atmosphere Supplements (1966), p. 69].

All altitudes reported are between ground level and 6.3 kilometers maximum. For all paths of sight at zenith angles less than 85 degrees or greater than 95 degrees,  $\Delta r$  equals  $\Delta z \sec\theta$  for these altitudes. The  $\Delta r$  is always nonnegative since  $\Delta z$  is defined as  $z_1 - z_2$  (the subscripts increase with the flux direction). See Fig. 2-1. The  $|\Delta z|$  used is 30 meters (98.4 feet). For zenith angles greater than 95 degrees, the beam transmittance can also be expressed as a function of the vertical beam transmittance  $T_r(z, 180^\circ)$  as follows:

$$T_r(z, \theta) = T_r(z, 180^\circ)^{|\sec\theta|}. \quad (2.4)$$

For upward paths of sight for zenith angles less than 85 degrees the beam transmittance can similarly be expressed as a function of the vertical upward transmittance  $T_r(z, 0^\circ)$ . The computations described above are useful in determining  $T_r$  for a variety of zenith angles, however, the data included in Section 7 of this summary report are restricted to the vertical path only.

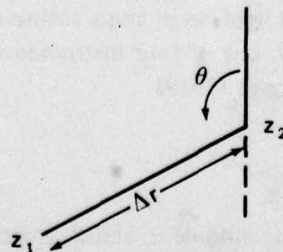

Fig. 2-1. Path Length Geometry for Steeply Inclined Paths of Sight.

## ATTENUATION LENGTH

The attenuation length  $L(z)$  is defined as the reciprocal of the atmospheric attenuation coefficient  $\alpha(z)$ . Therefore, when there is no significant absorption, it is also equivalent to the reciprocal of the atmospheric total volume scattering coefficient:

$$L \equiv \frac{1}{\alpha(z)} = \frac{1}{s(z)} \quad (2.5)$$

The equivalent attenuation length  $\bar{L}(z)$  is a pseudo-attenuation length which, when combined with its altitude  $z$ , can be used directly in the equation [Boileau (1964), Eq. 6.1]

$$T_r(z, \theta) = \exp[-z/\bar{L}(z)]|\sec\theta| \quad (2.6)$$

where  $\theta > 95^\circ$  and path length  $r$  is between ground level and altitude  $z$ . Combining Eq. 2.6 and Eq. 2.2 and appropriately rearranging, the following expression may be obtained for equivalent attenuation length,

$$\bar{L}(z_n) = \frac{z_n}{\sum_{i=1}^n s(z_i) \Delta z} \quad (2.7)$$

For  $\theta < 85^\circ$ , the  $\bar{L}(z)$  values should be interpreted as applying to the object altitude with the sensor at ground level.

## EARTH CURVATURE AND REFRACTION

For the paths of sight at zenith angles from 90 to 95 degrees, the  $\Delta r$  for  $|\Delta z| = 30$  meters (98.4 feet) is significantly longer at ground level than at 6 kilometers due to the curvature of the earth. Also for upward-looking paths of sight from 85 to 90 degrees, the  $\Delta r$  for  $\Delta z = 30$  meters (98.4 feet) is significantly shorter at 6 kilometers than at ground level due to the curvature of the earth. Thus for paths of sight between 85 and 95 degrees in zenith angle, Eqs. 2.4 and 2.6 should not be used. Instead, Eq. 2.2 should be used with the appropriate  $\Delta r$  values.

## DOWNWELLING IRRADIANCE

The downwelling irradiance on a horizontal flat plate may be defined by the equation

$$H(z, d) \equiv \int_{2\pi} N(z, \theta', \phi') \cos\theta' d\Omega \quad (2.8)$$

where  $N(z, \theta', \phi')$  is the radiance at altitude  $z$  in the direction of zenith angle  $\theta'$  and azimuth  $\phi'$ . The downwelling irradiance was measured by a dual irradiator which performed the integration in Eq. 2.8 optically with a cosine-law collector. During the ascents and descents of the aircraft when total volume scattering coefficient was being measured, the dual irradiator was simultaneously measuring downwelling irradiance. The downwelling irradiance provides a quantitative measure of the ambient flux levels during the flight.

### UPWELLING IRRADIANCE

The upwelling irradiance on a horizontal flat plate is designated by  $H(z, u)$ . The dual irradiator alternately measured upwelling and downwelling irradiance at low, intermediate, and high altitude during intervals of straight and level flight which preceded or followed the ascents and descents.

### ALBEDO

Albedo  $A(z)$  is defined as

$$A(z) \equiv H(z, u)/H(z, d) . \quad (2.9)$$

Albedos were determined from the upwelling and downwelling irradiance measurements made with the dual irradiator during the straight and level flight intervals for each flight.

### RELATIVE HUMIDITY

The relative humidity is computed using the measured ambient temperature, the measured dewpoint temperature and their associated partial pressures of water vapor. The relative humidity in percent is computed from the equation

$$RH = [P(d)/P(t)] 100 . \quad (2.10)$$

where  $P(d)$  is the saturated vapor pressure at dewpoint or frostpoint temperature, and  $P(t)$  is the saturated vapor pressure at ambient temperature. The saturated vapor pressures over water and over ice are obtained from List (1966).

### 3. INSTRUMENTATION

The scientific instrumentation utilized for the Project OPAQUE III task was basically the same as that reported in AFCRL-TR-75-0457, Duntley, *et al.* (1975b) and AFGL-TR-76-0188, Duntley, *et al.* (1976). Consequently, the descriptions contained herein have been edited to include only those systems directly related to the scattering coefficient and irradiance data. The total instrumentation package utilized during the Project OPAQUE III deployment is illustrated in Fig. 3-1 and 3-2.

#### 3.1. RADIOMETRIC SYSTEMS

Of the seven different types of radiometric collector assemblies mounted on board the aircraft, only two have their descriptive summaries included in this report, the integrating nephelometer and the dual irradiator.

##### INTEGRATING NEPHELOMETER (NEPH) ASSEMBLY

In order to measure and evaluate the total volume scattering coefficient for typical real aerosols, the Visibility Laboratory has devised and built an instrument referred to as an integrating nephelometer. The basic structure of the device consists of the subassembly illustrated in Fig. 3-3 and an enclosing light tight box. In the airborne version, ram air driven by the aircraft's forward velocity is routed through the box via four one-inch diameter inlet tubes and four one and one-half inch diameter exhaust tubes.

In its operational mode, the integrating nephelometer measured the radiant flux scattered by the transient aerosol as it passes through the geometrically well defined flux beam from a high intensity projector. The scattered flux is sequentially collected through one of three different optical channels: two telescopes, each having 2-degree circular fields of view oriented to collect the flux scattered in the  $\beta=30^\circ$  and  $\beta=150^\circ$  directions, and one  $2\pi$  irradiator assembly oriented to collect the flux scattered in all scattering angles between  $\beta=5^\circ$  and  $\beta=172.5^\circ$ . From these measurements plus the measurement of a well defined calibration flux level, the directional scattering functions  $\sigma(30)$  and  $\sigma(150)$  and the total volume scattering coefficient  $s$  may be derived.

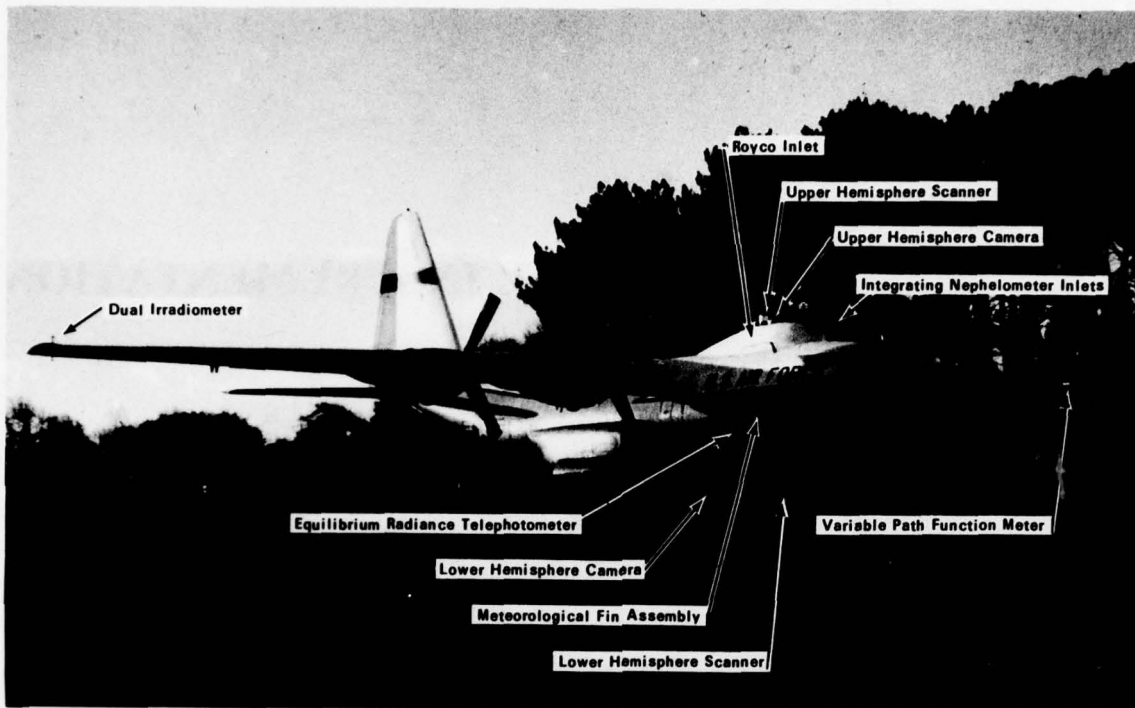

Fig. 3-1. C-130 Airborne Instrument System

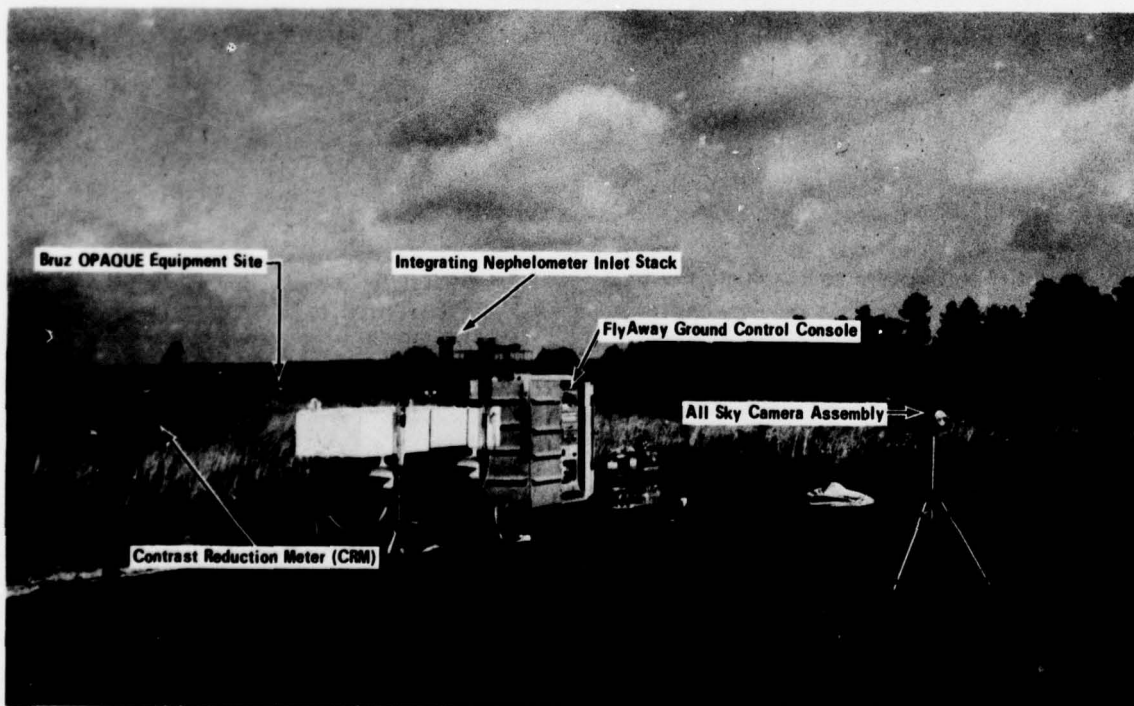

Fig. 3-2. Ground-Based Instrument System

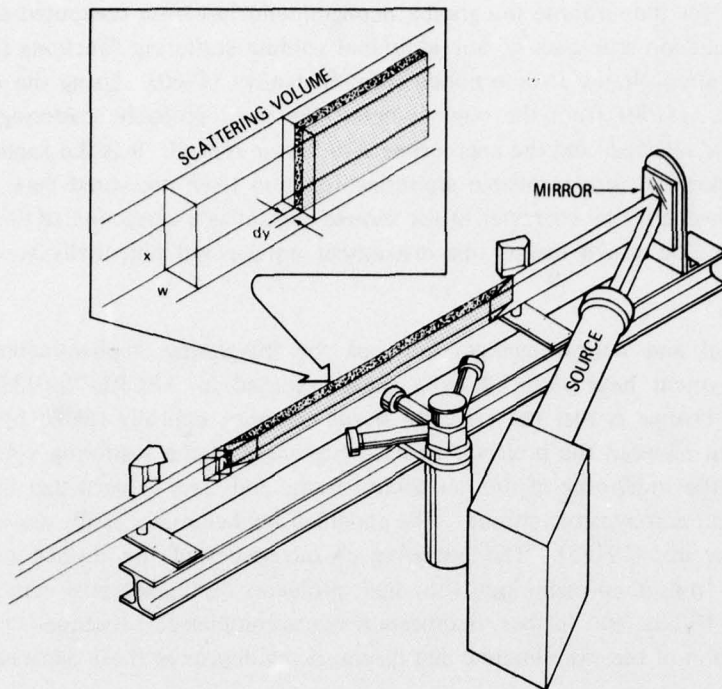

Fig. 3-3. Artist's Rendition of Modified Integrating Nephelometer

In its simplest form, the equation which is used to compute the total volume scattering coefficient is

$$s = \frac{H K}{H F} \quad (3.1)$$

where

$H$  is the flux scattered from the beam and collected by the instrument's irradiator channel while in the operational mode, and

$H$  is the flux reflected from a diffusely reflecting calibration plaque and collected by the irradiator channel while the instrument is in the calibration mode.

The constants  $K$  and  $F$  are rather extensive integral expressions which relate the geometry of the scattering volume with respect to the irradiator cap location, the irradiance distribution in the flux beam, the transmittance and reflectance characteristics of the collector cap and calibration plaque, and the most probable shape of the scattering function associated with the sample aerosol.

The ratio  $K/F$  for the airborne integrating nephelometer has been computed using the Rayleigh volume scattering function and a set of ten additional volume scattering functions representative of a broad range of real atmospheres as determined from Barteneva (1960). Using the in-flight measured values of  $\sigma(30)$  and  $\sigma(150)$  from the nephelometer, the most probable scattering function for the sample aerosol can be selected, and the appropriate  $K/F$  factor applied. It is the application of this procedure for determining the most probable scattering function from measured data, and applying this supplementary knowledge of the character of the sample aerosol as a correction to the measurement for total scattering coefficient which makes this instrument unique and potentially superior for research applications.

The mechanical and optical configurations of the integrating nephelometer utilized on the OPAQUE III deployment have changed from those reported in AFCRL-70-0137, Duntley, *et al.* (1970a). The basic change is that the projector beam has been optically folded by inserting a plane mirror into the beam between the projector and the beginning of the scattering volume. This optical folding has enabled the shortening of the mechanical frame and housing such that the entire assembly can be enclosed in an aerodynamic shroud. The modified nephelometer is illustrated in AFCRL-TR-75-0457, Duntley, *et al.* (1975b). The operating characteristics of the revised nephelometer were discovered to suffer from abnormally high stray light problems during the post deployment analysis of the OPAQUE I and II data, and further modification was accomplished subsequent to its return to the Laboratory. Evaluation of the experimental and diagnostic evidences of these apparent stray light problems is continuing.

The modified nephelometer is enclosed in the modified radome shown on top of the aircraft in Fig. 3-1, and an artist's rendition of the modified arrangement of the internal subassemblies is illustrated in Fig. 3-3.

#### DUAL IRRADIOMETER (DI) ASSEMBLY

The dual irradiometer assembly is a two-channel irradiometer. It has two optical input channels but only one optical output. A rotating prism subassembly allows the system operator to select either input channel for optical coupling with the output channel, while simultaneously occulting the other. The resultant time-sharing of a single detector assembly yields a device optimized for ratio type measurements.

The flat plate diffuse collector surfaces used in this assembly are mechanically corrected to yield cosine collection characteristics between 0 and 90 degrees which are within  $\pm 2$  percent of true cosine for all angles of incidence between 0 and 80 degrees.

The dual irradiometer assembly is mounted on the aircraft wingtip so that the flat plate collectors are horizontal during normal straight and level (ST&LV) flight elements. In this configuration the upper channel receives radiant flux from the entire hemisphere above the aircraft, and the lower channel receives radiant flux from the entire hemisphere below the aircraft. These measurements of downwelling and upwelling irradiance can be used both in the calculation of directional terrain reflectances, albedos and in intersystem data validation checks.

### 3.2. METEOROLOGICAL SYSTEMS

All of the meteorological systems utilized in this project were purchased items; the operating characteristics of each are available in the appropriate manufacturer's brochures. For use in Project OPAQUE III, the meteorological systems were unchanged from the configurations reported in AFCRL-72-0593, Duntley, *et al.* (1972c).

The airborne meteorological package consisted of one Royco Model 220 particle counter, one Cambridge Model 137-C3 aircraft hygrometer system, one AN/AMQ-17 aerograph set, and two Bourns aneroid pressure transducers.

Since all of the meteorological systems were described in AFCRL-72-0593, Duntley, *et al.* (1972c), no further discussion is included in this report.

### 3.3. CONTROL AND COMMUNICATION SYSTEMS

The basic control panels, consoles, and other support facilities associated with the airborne instrument system are described fully in AFCRL-70-0137, Duntley, *et al.* (1970a) and the updated configurations are reported in AFCRL-72-0593, Duntley, *et al.* (1972c).

### 3.4. PHOTOGRAPHIC SYSTEMS

Photographic documentation of the test environment performed simultaneously with the radiometric and meteorological measurements has always been a highly desirable adjunct to any field activity. For Project OPAQUE III, this photographic capability was accomplished by the Visibility Laboratory through the use of two camera systems.

#### AIRBORNE AUTOMAX G-1 CAMERA SYSTEM

Two 35-millimeter Automax G-1 cameras, modified to accept Traid 735 Periphoto (180-degree) lenses, were mounted on the project aircraft (Fig. 3-1). One camera was oriented to photograph the  $2\pi$  upper hemisphere and the other covered the  $2\pi$  lower hemisphere. Either or both cameras may be run in either cine or single-frame modes at the discretion of the operator.

The photographs from these cameras are used only as general background for the interpretation of the radiometric measurements. Thus, no special controls are placed upon the film or its processing. For this general-purpose application, the cameras are normally loaded with Kodak Ektacolor Professional S, No. 5026 film. Typical photographs from this system are used as illustrations in Section 7 of this report and were shot with a fixed f6.3 aperture in the single-frame mode.

#### GROUND-BASED SOLIGOR SYSTEM

The ground-site documentation photographs have historically been limited to 35-millimeter color snapshots, taken on a casual basis during lulls in the experimental sequences. For Project OPAQUE III

this procedure was supplemented with a scheduled routine of site photographs using a Soligor Conversion Fisheye lens. This lens possesses almost universal adaptability to a wide variety of cameras and prime lenses. During Project OPAQUE III it was used on a Yashica, Lynx 1000.

### 3.5. RADIOMETRIC CALIBRATION PROCEDURES

All the radiometers used in this project are calibrated in essentially the same manner. In each case, the system is calibrated first by determining its relative flux versus high voltage characteristics over the anticipated operating span and second by establishing known absolute flux levels on this voltage curve. The entire calibration procedure is conducted by using standard photometric practices, a 3-meter optical bench, and incandescent standards of luminous intensity traceable to the National Bureau of Standards.

A detailed discussion of these calibration procedures is contained in AFCRL-70-0137, Duntley, *et al.* (1970a), AFGL-TR-76-0188, Duntley, *et al.* (1976), and most of the intervening reports in this series. The discussion therefore will not be repeated herein.

A typical data sheet for the absolute calibration of a Project OPAQUE III radiometer is shown in Fig. 3-4. Five different levels of input radiance are used in the determination of the calibration constant for the system. The calibration constant is referred to as the zero scale value and is labeled ZSV on the calibration forms.

ABSOLUTE CALIBRATION FORM  
(30) NEPH-1 SIGMA (21253 NS) ( IRRADIOMETER TAKEN ON 6/ 9/77 (PREOPUS) DEPLOYMENT  
FILTER NO. 4 (XEND) 5500 DEGREES KELVIN)

SPAN ID	D1 CM	TOTAL DIST. CM	TOTAL DIST. SQ. CM. SQ.	CALC. IRR. B OR E *	DETEC. RAW OUTPUT	LOG OF (K/M)	RAW ZSV	PERCENT DIFF OF RAW AVG	AVG RAW ZSV	F1 LUM. TO RAD. WATTS/LUM.	F2 LUM. MATCH	CORRECTED ZSV
1	40	116.300	1.3536 04	7.566E-05	494	0	0	0	5.136E-05	1.050E-03	1.017E 00	5.467E-06
2	70	146.300	2.140E 04	4.794E-05	400	.129	5.107E-05	.6				
3	120	196.300	3.853E 04	2.661E-05	471	.289	5.134E-05	.1				
4	200	276.300	7.634E 04	1.344E-05	386	.579	5.101E-05	.7				
5	300	376.300	1.416E 05	7.246E-06	344	.939	5.081E-05	2.7				
5	300	376.300	1.416E 05	7.246E-06	344	.939	5.081E-05	2.6				
4	200	276.300	7.634E 04	1.344E-05	385	.585	5.137E-05	-.6				
3	120	196.300	3.853E 04	2.661E-05	470	.292	5.219E-05	-1.4				
2	70	146.300	2.140E 04	4.794E-05	465	.349	5.376E-05	-4.5				
1	40	116.300	1.353E 04	7.566E-05	493	0	0	0				

LINEARITY MAXIMUM = ( .472) APPLIED CUTOFF = ( -.812)  
LINEARITY CALIB. END = ( -.932) FULL DARK = ( .005) CUTOFF = ( -.812)

\* CALCULATED ILLUMINANCE IN LUMENS/SQ. CM.

RAW ZSV STD = ( 1.1693E-06) FRACT. STD = ( 2.33) PERCENT ZSV IN WATTS/SQ. CM. IS 5.467E-06  
WITH UNIT CONVERSION FACTOR OF ( 127300.00000) CHANGE UNITS FROM ( W. SQ. CM.) TO ( W. SQ. CM. (ICM) ) THE NEW ZSV IS WATTS/SQ. CM. IS 6.98458E-03

THIS FILTER IS PSEUDO-PHOTOPIC. TO CONVERT TO TRUE PHOTOPIC STANDARD (SEE TECHNICAL MEMORANDUM AV71-0031)  
FOR DAYLIGHT DATA MULTIPLY BY 72.00 LUMEN-UM / WATT. PHOTOPIC ZSV IS 5.02890E-01 LUMEN/ SQ M.  
FOR NIGHT TIME LIGHTING MULTIPLY BY 68.54 LUMEN-UM / WATT. PHOTOPIC ZSV IS 4.77326E-01 LUMEN/ SQ M.  
FOR NEPHELOMETER ONLY MULTIPLY BY 72.71 LUMEN-UM / WATT. PHOTOPIC ZSV IS 5.04198E-01 LUMEN/ SQ M.

HV FLUCTUATION DATA DURING EACH CALIB MEASUREMENT			CALIBRATION LAMP IDENTIFICATION		CALIBRATION TARGET DATA	
SPAN ID	STD. DEV. IN HV	FRACT STD DEV IN PERCENT	SERIAL NUMBER *	VLAB201 LAMP INTENSITY *	REFLECTANCE OF PATH ATTENUATOR (PERCENT) =	REFLECTANCE OF CALIBRATION TARGET (PERCENT) =
2	4.425E-01	9.455E-02		20.52	9.0	100.0
3	3.051E-01	8.472E-02		28.54		
4	3.416E-01	8.846E-02		28.54		
5	2.906E-01	7.266E-02		28.54		
5	0	0		28.54		
4	4.672E-01	1.161E-01		28.54		
3	4.256E 00	9.885E-01		28.54		
2	0	0		28.54		
1	5.680E-01	1.018E-01		28.54		

PHOTOMETER DATA CHANNEL = 1

Fig. 3-4. Typical Absolute Calibration Form.

## CALIBRATION CORRECTION FACTORS

Several calibration correction factors are used with the calibration data illustrated in Fig. 3-4 to generate the calibration constants listed in Table 3.1. In general, the factors are used at will to convert radiometric units into photometric units and reconvert them, and to adjust the value of measurements taken with an instrument having a nearly standard spectral response to the value that would have been obtained using the exact standard spectral response specified in Section 3.6.

These correction factors are discussed at length in AFCRL-70-0137 and AFCRL-72-0461, Duntley, *et al.* (1970a and 1972b). Thus, they are not discussed further at this time.

### 3.6. STANDARD RESPONSE CHARACTERISTICS FOR BROAD BAND SENSORS

All the radiometric instruments both ground-based and airborne used by the atmospheric visibility branch are equipped with automatic filter changing assemblies. Thus any one of five different spectral filters can be interposed into each instrument's optical path. The combination of the sensor sensitivity  $S_\lambda$  and the filter transmittance  $T_\lambda$  is the resultant sensitivity of the filtered phototube  $S_\lambda T_\lambda$ . The standard responses which each optical system attempts to duplicate are indicated as  $\overline{S_\lambda T_\lambda}$ , and are illustrated in Table 3.2. No system has true photopic response, Filter Code 9, but this ideal response is included for comparative purposes only.

A summary of the response characteristics of the standards for Project OPAQUE III is presented in Table 3.3. The first four columns give filter code, peak wavelength, mean wavelength, and response area, terms which are fully defined in preceding reports such as AFGL-TR-76-0188, Duntley, *et al.* (1976). The values for inherent solar properties are in columns 5, 6, and 7, and the Rayleigh limits are in columns 8, 9, 10. The table was produced by Program RAYLIMIT.

**Table 3.1. Project OPAQUE III Radiometer Calibration Constants (ZSV) and Related Fractional Standard Deviations ( $\delta$ ) for Daylight Flights**

Radiometer Identification		Calib Mode	Calib Units	Filter 2		Filter 4		Filter 3		Filter 5		Average $\delta$ % for System
System	MPT SN			ZSV	$\delta$ %	ZSV	$\delta$ %	ZSV	$\delta$ %	ZSV	$\delta$ %	
NEPIII $\Sigma$	21253	Out	w/m <sup>2</sup> $\mu$ m	2.00E-02	1	6.98E-03	2	3.91E-02	2	4.52E-01	3	2
NEPIII $\beta$ 30	21253	Out	w/ $\Omega$ m <sup>2</sup> $\mu$ m	1.81E-02	2	7.19E-03	1	4.61E-02	1	6.85E-01	2	1
DI*	9858	In	w/m <sup>2</sup> $\mu$ m	4.25E+04	13	1.10E+04	3	4.00E+04	7	8.83E+04	11	8
DI*	9858	In	w/m <sup>2</sup> $\mu$ m	5.10E+04	20	1.25E+04	4	4.48E+04	10	9.18E+04	12	12

\*For DI use first set on Flts. C-410 through C-412, second set on C-413 through C-422.

**Table 3.2. Relative Spectral Response of Standards for Project OPAQUE III**

Filter Identification and Mean Wavelength							Filter Identification and Mean Wavelength						
Wave-length (nm)	No. 2 Blue 478nm	No. 3 Red 664nm	No. 4 Pseudo- Photopic 557nm	No. 5 NIR 765nm	No. 6 S-20 532nm	No. 9 True Photopic 560nm	Wave-length (nm)	No. 2 Blue 478nm	No. 3 Red 664nm	No. 4 Pseudo- Photopic 557nm	No. 5 NIR 765nm	No. 6 S-20 532nm	No. 9 True Photopic 560nm
400	0	0	0	0	0	0.0004	615	0	0	0.1680	0	0.4500	0.4412
405	0	0	0	0	0.0129	0.0006	620	0	0	0.1300	0	0.4390	0.3810
410	0	0	0	0	0.0258	0.0012	625	0	0	0.1055	0	0.4260	0.3210
415	0	0	0	0	0.2969	0.0022	630	0	0	0.0810	0	0.4130	0.2650
420	0	0	0	0	0.5680	0.0040	635	0	0.0020	0.0657	0	0.3935	0.2170
425	0	0	0	0	0.7605	0.0073	640	0	0.0486	0.0504	0	0.3740	0.1750
430	0	0	0	0	0.9530	0.0116	645	0	0.1798	0.0411	0	0.3545	0.1382
435	0	0	0	0	0.9765	0.0168	650	0	0.5531	0.0318	0	0.3350	0.1070
440	0	0	0	0	1.0000	0.0230	655	0	0.9948	0.0268	0	0.3190	0.0816
445	0	0	0	0	0.9920	0.0298	660	0	1.0000	0.0218	0	0.3030	0.0610
450	0	0	0	0	0.9840	0.0380	665	0	0.9421	0.0188	0	0.2845	0.0446
455	0	0	0	0	0.9720	0.0480	670	0	0.8625	0.0157	0	0.2660	0.0320
460	0.0070	0	0	0	0.9600	0.0600	675	0	0.7482	0.0139	0	0.2480	0.0232
465	0.1487	0	0	0	0.9510	0.0739	680	0	0.4774	0.0120	0	0.2300	0.0170
470	0.8481	0	0	0	0.9420	0.0910	685	0	0.1585	0.0105	0	0.2105	0.0119
475	1.0000	0	0.0172	0	0.9355	0.1126	690	0	0.0495	0.0090	0	0.1910	0.0082
480	0.9329	0	0.0343	0	0.9290	0.1390	695	0	0.0166	0.0080	0	0.1755	0.0057
485	0.8304	0	0.0677	0	0.9175	0.1693	700	0	0	0.0070	0	0.1600	0.0041
490	0.1790	0	0.1010	0	0.9060	0.2080	705	0	0	0.0061	0	0.1445	0.0029
495	0.0292	0	0.1185	0	0.8920	0.2586	710	0	0	0.0053	0	0.1290	0.0021
500	0	0	0.1360	0	0.8780	0.3230	715	0	0	0.0048	0	0.1170	0.0015
505	0	0	0.2635	0	0.8560	0.4073	720	0	0	0.0042	0	0.1050	0.0010
510	0	0	0.3910	0	0.8340	0.5030	725	0	0	0.0038	0.1005	0.0938	0.0007
515	0	0	0.5085	0	0.8135	0.6082	730	0	0	0.0033	0.2010	0.0826	0.0005
520	0	0	0.6260	0	0.7930	0.7100	735	0	0	0.0030	0.4155	0.0723	0.0004
525	0	0	0.7345	0	0.7715	0.7932	740	0	0	0.0026	0.6300	0.0619	0.0003
530	0	0	0.8430	0	0.7500	0.8620	745	0	0	0.0025	0.8150	0.0558	0.0002
535	0	0	0.9065	0	0.7250	0.9149	750	0	0	0.0023	1.0000	0.0497	0.0001
540	0	0	0.9700	0	0.7000	0.9540	755	0	0	0.0020	0.9595	0.0416	0.0001
545	0	0	0.9850	0	0.6785	0.9803	760	0	0	0.0018	0.9190	0.0335	0.0001
550	0	0	1.0000	0	0.6570	0.9950	765	0	0	0.0017	0.8495	0.0292	0
555	0	0	0.9665	0	0.6385	1.0002	770	0	0	0.0016	0.7800	0.0249	0
560	0	0	0.9330	0	0.6200	0.9950	775	0	0	0.0014	0.6620	0.0206	0
565	0	0	0.8685	0	0.6030	0.9786	780	0	0	0.0013	0.5440	0.0162	0
570	0	0	0.8040	0	0.5860	0.9520	785	0	0	0.0012	0.4890	0.0144	0
575	0	0	0.7195	0	0.5700	0.9154	790	0	0	0.0012	0.4340	0.0125	0
580	0	0	0.6350	0	0.5540	0.8700	795	0	0	0.0012	0.3720	0.0107	0
585	0	0	0.5525	0	0.5385	0.8163	800	0	0	0.0011	0.3100	0.0088	0
590	0	0	0.4700	0	0.5230	0.7570	805	0	0	0.0005	0.2675	0.0075	0
595	0	0	0.3950	0	0.5060	0.6949	810	0	0	0	0.2250	0.0062	0
600	0	0	0.3200	0	0.4890	0.6310	815	0	0	0	0.1125	0.0031	0
605	0	0	0.2630	0	0.4750	0.5668	820	0	0	0	0	0	0
610	0	0	0.2060	0	0.4610	0.5030							

**Table 3.3. Spectral Characteristics Summary for Project OPAQUE III**

Spectral Characteristics for Project OPAQUE III				Inherent Sun Properties (Johnson)			Rayleigh Atmosphere Properties (15°C)		
Filter Code No.	Peak Wavelength (nm)	Mean Wavelength (nm)	Response Area (nm)	Irradiance ( $w/m^2\mu m$ )	Radiance ( $w/\Omega m^2\mu m$ )		Attenuation Length (m)	Total Scattering Coefficient (per m)	Vertical Beam Transmittance
					Average	Center			
2	475	478	19.9	2.14E+03	3.13E+07	4.07E+07	4.84E+04	2.07E-05	0.839
3	660	664	30.2	1.57E+03	2.30E+07	2.75E+07	1.86E+05	5.41E-06	0.955
4	550	557	78.5	1.90E+03	2.78E+07	3.47E+07	8.93E+04	1.15E-05	0.907
5	750	765	50.4	1.23E+03	1.80E+07	2.10E+07	3.28E+05	3.08E-06	0.974
6	440	532	183.5	1.91E+03	2.80E+07	3.55E+07	7.22E+04	1.64E-05	0.867
9	555	560	106.9	1.89E+03	2.77E+07	3.45E+07	9.22E+04	1.15E-05	0.907

## 4. DATA COLLECTION METHODS

During Project OPAQUE III, two independent activities were maintained simultaneously. The operation of the airborne instrument system was one activity and that of the ground-based instrument system was the other. The procedural routine was for each system to run full data collection sequences at every opportunity, on a daily schedule, as weather permitted.

### 4.1. AIRBORNE SYSTEM

The data collection sequence for the airborne system was broken into five standardized elements: (1) preflight warmup and calibration check, (2) straight and level sequences, (3) vertical profile sequences, (4) in-flight calibration checks, and (5) post-flight calibration check.

An illustration of our typical flight pattern which was used for most OPAQUE III flights, is shown in Fig. 4-1. In this stylized pattern, two basic elements, the straight and level (ST&LV) and the vertical profile (V-PRO), are combined to yield the total mission flight plan. A description of these two pattern elements and the calibration elements is detailed in AFCRL-72-0255, Duntley, *et al.* (1972a), modified in AFCRL-TR-75-0457, Duntley, *et al.* (1975b), and summarized in the following paragraphs.

1. Straight and Level runs (ST&LV), Mode 03 - The ST&LV runs are primarily  $2\pi$  scanner runs. The measurement of upper and lower hemisphere radiance distributions has top priority. One sky mode scanner pattern (192 seconds) plus one sun mode scanner pattern (64 seconds) are run at each altitude with each of the two optical filters.

During ST&LV runs the aircraft should maintain a fixed heading, a constant indicated airspeed of 150 knots or less, and a  $2\frac{1}{2}$  degree nose-high flight altitude.

2. Vertical Profile runs (V-PRO), Mode 07 - The V-PRO runs are primarily integrating nephelometer and variable path function meter runs. The measurement of the total scattering coefficient profile has top priority. Second priority is measurement of the vertical path function profile. Each V-PRO ascent or descent is made using a single filter.

During the V-PRO runs the aircraft should maintain a fixed heading, with the sun off the left wingtip, and a flight attitude not exceeding 4 degrees nose down or 8 degrees nose up. An average rate of climb or descent of 1200 feet/minute is optimum, and airspeed is not critical, but should remain constant once established.

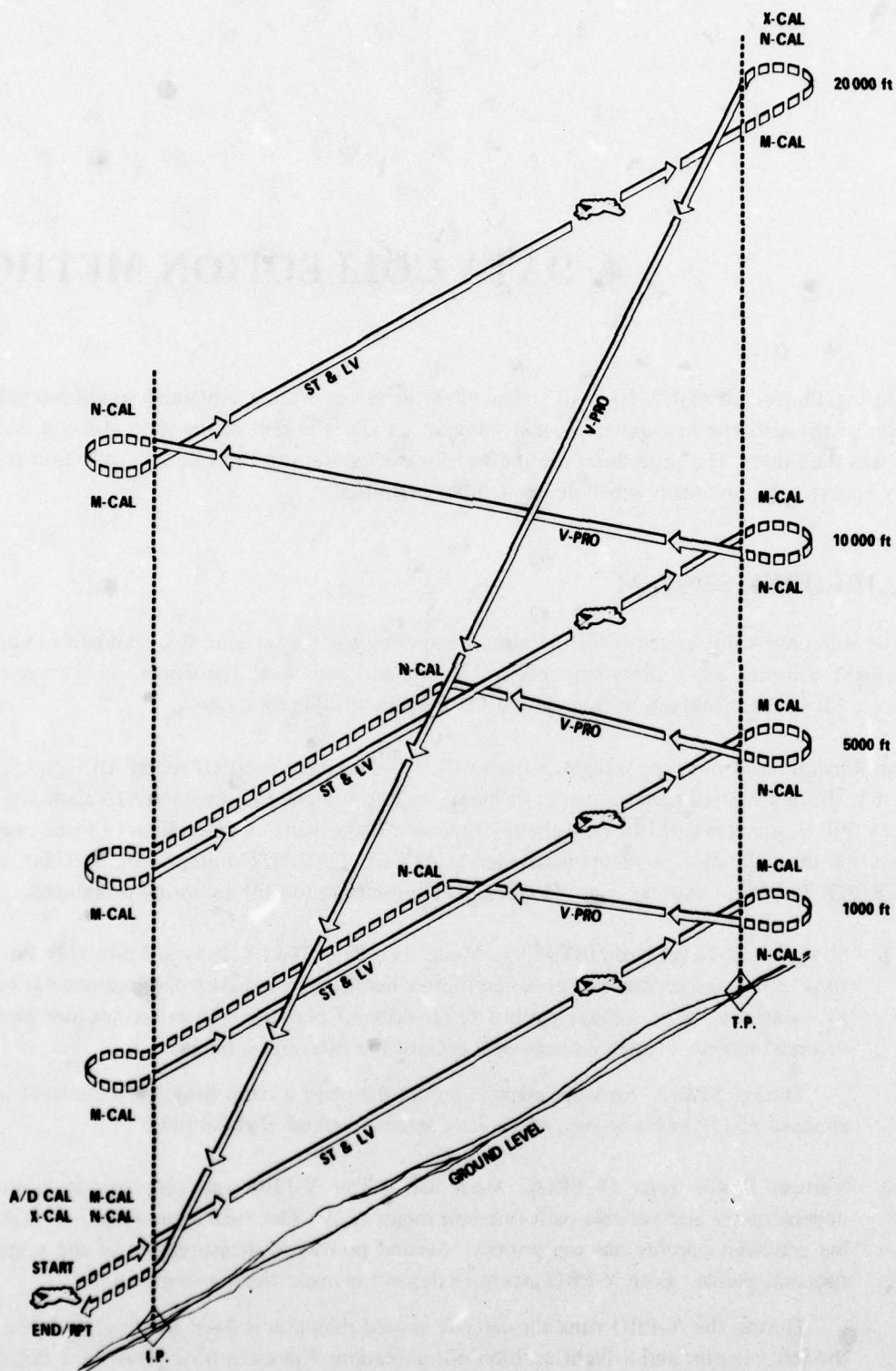

Fig. 4-1. Typical Visibility Laboratory Flight Profile

3. Cross-Calibration Climbs (X-CAL), Mode 08 - The X-CAL climbs are specifically designed to validate the performance of the UHS, LHS, and ERT radiometer systems. The simultaneous measurement of a common uniform segment of sky by these three radiometers has top priority. Two X-CAL climbs are associated with each standard profile, one preceding the first ST&LV run and the second following the last ST&LV run. Both sky mode and sun mode measurements are made with the UHS system.

During the 4-minute X-CAL climb the aircraft should maintain a fixed heading, with the sun in the aft hemisphere, and a 5-degree nose-high flight attitude. The aircraft should be flown directly toward the clearest and most uniform portion of the sky as practical.

4. Calibration Blocks (A/D CAL), Mode 00, M-CAL, Mode 01, N-CAL, Mode 09 - The 32-second blocks of calibration data are inserted periodically throughout the entire data mission. They are designed to provide calibration update information to the post-flight computer processing sequences. There are 21 assorted calibration blocks associated with each (2+4) profile.

During these calibration blocks there are no project-imposed requirements upon aircraft speed or attitude.

## GENERAL FLIGHT PATTERN

The standard (2+4) profile is illustrated in Fig. 4-1. In this profile, ST&LV data runs are made using two different spectral filters at each of four altitudes. The ascent V-PRO is made using the first of the two filters, and the descent V-PRO is made using the second. After the descent V-PRO, the entire sequence is repeated using a second pair of filters.

The idealized flight profile would result in all ground tracks falling on a single line running between the Initial Point (I.P.) and the Turning Point (T.P.). See Fig. 4-1. In practice, the ST&LV elements are actually stacked in a slab of atmosphere approximately 30 miles long, 0.5 mile wide, and 4 miles high.

Periodically, in response to specialized data requirements or weather conditions, supplementary flight patterns are added to the mission profile. For OPAQUE III, a pattern made up of a (2+3) profile, i.e., two spectral filters at each of three altitudes was used as was a (2+2) profile, i.e., two spectral filters at each of two altitudes. Both the (2+3) and (2+2) profiles are generally considered low to medium altitude profiles, and are normally used on flights performed under a full overcast or low to intermediate level cloud decks. Two flights consisted of V-PRO climb outs, supplemented with only directional scattering measurements at the the minimum and maximum altitudes.

At the conclusion of each mission, the radiometric data which were recorded and stored on magnetic tape were returned to the Visibility Laboratory for computer reduction and analysis.

## 4.2. GROUND-BASED SYSTEM

The ground-based data collection sequence was designed to supplement the airborne data whenever the aircraft was operating in the immediate vicinity. However, it is also complete enough to stand alone when the aircraft mission is diverted or aborted.

During the OPAQUE III deployment, the fly-away Contrast Reduction Meter (CRM) and an integrating nephelometer were used on the ground station.

The primary function of the CRM system is to determine the earth-to-space beam transmittance for comparison with the data from the airborne systems. The basis for the measurement techniques utilizing the CRM was first presented by Gordon, *et al.* (1963) and validated by Duntley, *et al.* (1964). It is also discussed in Edgerton (1967) and summarized in Gordon, *et al.* (1973). A similar configuration of the device is described in Duntley, *et al.* (1970b).

The operational and computational procedures related to the CRM system are described in detail in Duntley, *et al.* (1972b), and briefly summarized in the following paragraph.

Four basic measurements using the CRM are required in order to provide proper inputs to the computation of earth-to-space universal contrast transmittance. They are:

1. Apparent Solar Radiance.
2. Path Radiance, i.e., Sky Radiance, at an appropriate scattering angle from the sun.
3. Total Downwelling Irradiance.
4. Inherent Background Radiance, i.e., generally a selected terrain radiance.

Since the CRM is conceived as a clear day system, requiring clear skies, its daily data collection schedule was often cut short, or aborted by poor weather during the OPAQUE III deployment. Under highly variable weather conditions, priority is assigned to measurements of apparent solar radiance in order to retrieve a maximum number of determinations for atmospheric beam transmittance. These measurements are recorded manually for subsequent insertion into the automatic data processing and evaluation procedure.

The ground based integrating nephelometer utilized during OPAQUE III was a folded path device, optically equivalent to the airborne system. It was constructed using the major mechanical and optical components from an earlier truck mounted system.

This rebuilt ground based integrating nephelometer and the airborne model use identical detectors, mode selector heads, calibrators, and mirror assemblies. The projectors are both 500 watt Xenon, however there are minor differences in the lamp housings. The only real difference between the two systems is in the shroud design. The ground based shroud is considerably larger, hence the interior stray light problems should be smaller. The light trap for the ground nephelometer projector beam is further from the sampling volume and is a more efficient design; thus its influence on the scattering volume should be less. The ground based shroud has a built-in exhaust fan to draw the aerosol through the main shroud instead of using ram air as does the airborne model. Data recording, as with the CRM, was manual.

## 5. DATA PROCESSING

As in any reasonably complex, multi-input sampled data system, there is a large amount of data handling required before the scientific analyst ever sees the package. The degree of data processing sophistication utilized during this contract interval is illustrated in Fig. 5-1 and 5-2. In these generalized flow charts, the basic functional steps used in the data processing of the raw field data are clearly specified. They do not illustrate, however, all of the miscellaneous routines used for data base management and special diagnostic purposes. A more complete description of each phase of the processing sequence is contained in AFCRL-72-0255, AFCRL-72-0593, Duntley, *et al.* (1972a and c), and AFCRL-TR-75-0457, Duntley, *et al.* (1975b).

### 5.1. AIRBORNE DATA

As described in AFCRL-72-0255, Duntley, *et al.* (1972a), several classes of data are recorded during an airborne data set: (1) radiometer outputs, (2) selector control codes, (3) transducer orientation and flight attitude signals, and (4) calibration voltages, etc. All systems, regardless of type, have been designed for an electrical output between 0 and  $\pm 1$  volt dc for full scale. The 42-channel data logger has a least count of  $\pm 1$  millivolt and records in digital format at a multiplex rate of 240 samples per second and a tape rate of 3.56 inches per second at a recording density of 200 bits per inch.

Several major improvements to the airborne data processing procedure have been implemented during the interval since AFCRL-72-0593, Duntley, *et al.* (1972c) and AFCRL-TR-75-0457, Duntley, *et al.* (1975b). The insertion of these programs is summarized in AFGL-TR-76-0188, Duntley, *et al.* (1976) and is illustrated in Fig. 5-1. These programs, and the increased diagnostic capabilities that their usage has enabled, have materially improved the quality of the upper hemisphere radiance maps, and thus the quality of all subsequently computed optical atmospheric properties.

In order to produce the data included in this short form report, it was not necessary to run the programs illustrated in the upper portion of Fig. 5-1. That is, those programs related to the processing of automatic scanner data, MIRESCAN, SCANTSUM, etc., were bypassed. In this manner the AVIZC130 runs were shortened to only the first overlay for the production of scattering coefficient and beam transmittance profiles.



**GROUND DATA PROCESSING:**

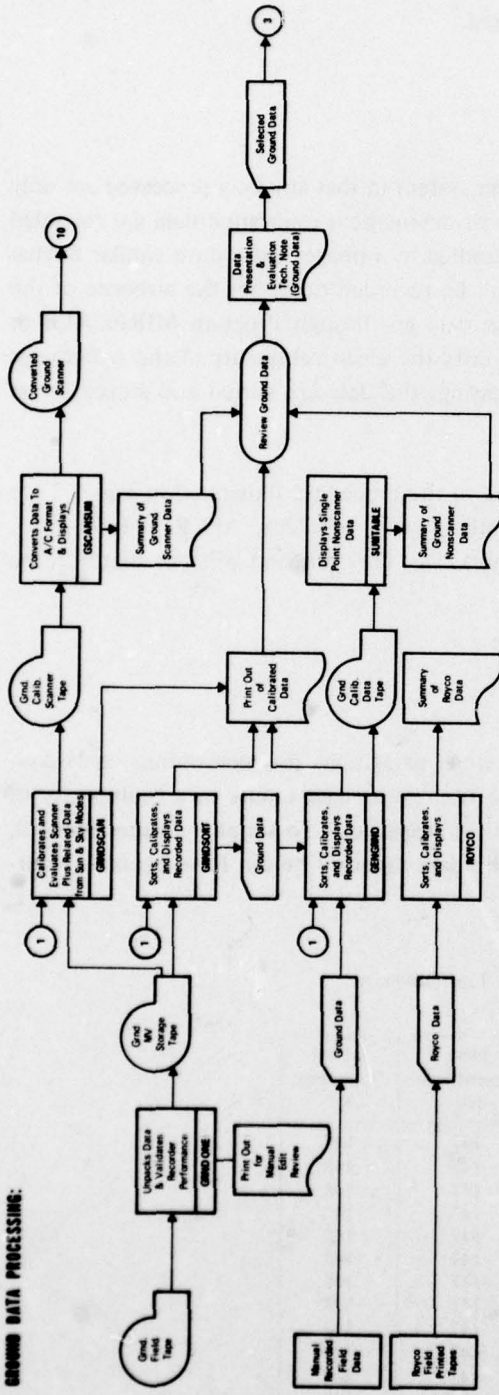

**CALIBRATION DATA PROCESSING:**

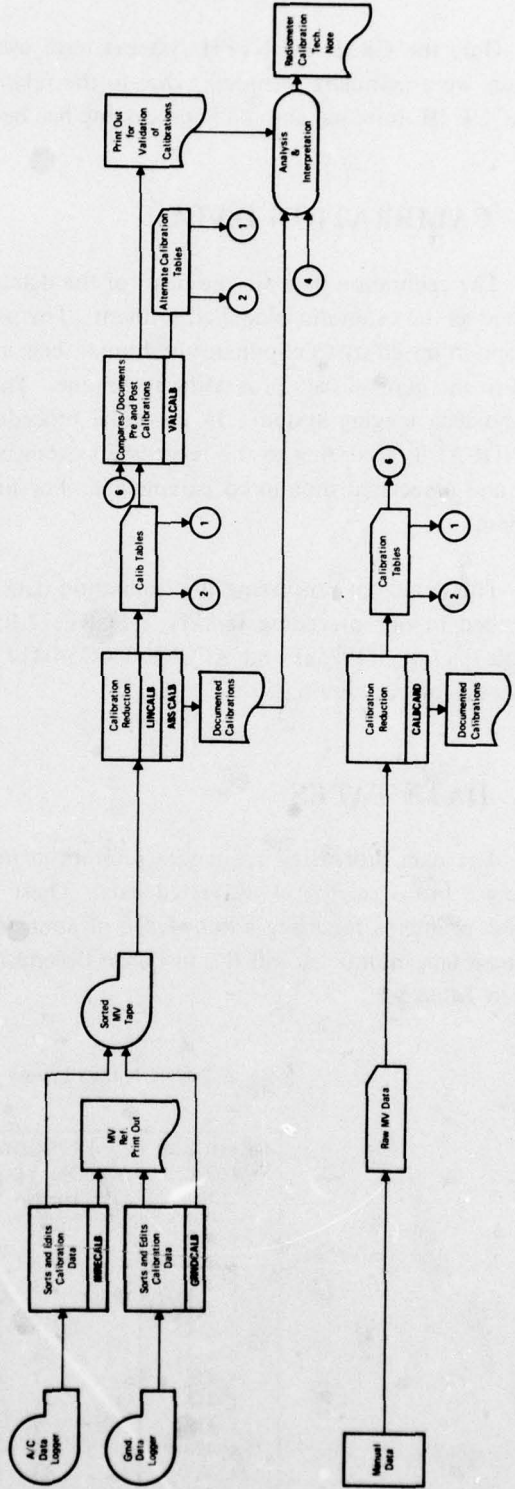

Fig. 5-2. Atmospheric Visibility Program Data Processing Schedule.

## 5.2. GROUND-BASED DATA

Only the CRM and NEPH systems were used for the collection of ground-based data and their outputs were manually recorded. Due to the relatively small quantities of ground data acquired during OPAQUE III, minimal automatic processing has been required.

## 5.3. CALIBRATION DATA

The calibration data are the heart of the data processing system in that any data processed are only as good as the calibrations applied to them. The pre- and post-deployment calibration data are recorded on tape in an effort to eliminate the human bias and are handled in a phased procedure similar to that used in the general data processing technique. The data can be recorded on either the airborne or the ground data logging system. In an initial procedure, these data go through Program MIRECALB or GRNDCALB, according to the recording system used, to verify the electrical quality of the radiometer data and associated monitored parameters. For final processing, the data are sorted and stored in set fashion.

The details of processing the calibration data according to the procedure illustrated in Fig. 5-2 are described in our preceding reports, AFCRL-72-0593, Duntley, *et al.* (1972c), AFCRL-TR-75-0457, Duntley, *et al.* (1975a) and AFCRL-TR-75-0414, Duntley, *et al.* (1975b), and will not therefore be discussed further herein.

## 5.4. DATA TAPES

The data processing sequences referenced in the previous paragraphs produce output tapes containing a broad catalog of calibrated data. These tapes are useable as data inputs to a multiplicity of diverse problems requiring a knowledge of atmospheric optical properties. To simplify future retrieval, the data tape numbers, and the in-house descriptions of the data reported herein have been summarized in Table 5.1.

Table 5.1. Data Library Composite Tape Summary

OPAQUE III Flight No.	DIOGEDIT Tape No. VL-369B File No.	Data Presentation No.	Edited Properties No.
C-410	1	147	148
C-411	2	147	148
C-412	3	147	148
C-413	4	147	148
C-414	5	147	148
C-415	6	147	148
C-416	7	147	148
C-418	12	147	148
C-419	9	147	148
C-420	10	147	148
C-421	13	147	148
C-422	11	147	148

## 6. WEATHER SUMMARY

### 6.1. INTRODUCTION AND GRAPHICS

Meteorological data available for analysis were provided by the Environmental Technical Applications Center (ETAC) at Scott Air Force Base. These data included daily and surface 500-millibar charts, surface observations, pilot reports, satellite photographs, vertical cross sections, and radiosonde data. Northern hemisphere surface charts for 0000 GMT and 1200 GMT and 500-millibar charts for 1200 GMT prepared by the National Oceanographic and Atmospheric Administration were obtained from the National Climatic Center in Asheville. Portions of the 1200 GMT surface charts have been reproduced as Fig. 6-1. The approximate flight track locations are indicated in Fig. 6-1 with the character ★. A later section includes tabular data of the hourly observations from stations in the vicinity of the flight track.

Airborne measurements of temperature and computed values of relative humidity, as derived from these measurements and simultaneous measurements of dewpoint temperature, are presented in Fig. 6-2 and 6-3. The temperatures were measured continuously by an AN/AMQ-17 aerograph system described briefly in AFCRL-70-0137, Duntley, *et al.* (1970a) and more completely in USNAF TP-133. The dewpoint/frostpoint temperatures were measured using a Cambridge 137-C3 Aircraft Hygrometer System which is described briefly in AFCRL-72-0593, Duntley, *et al.* (1972c).

The profile identification symbols used in Figs. 6-2 and 6-3 are related to the spectral filter sequence during which the data were measured; i.e., the temperature profile identified with the Filter 2 symbol was taken during the same time interval as the Filter 2 radiometric measurements; the temperatures coded as Filter 3 were taken simultaneously with the Filter 3 radiometric measurements, etc. Table 6-1, abstracted from program FLTDOC listings, summarizes the beginning and ending times associated with each flight element during which these meteorological and radiometric measurements were made. The time separations between profiles are substantial and should be carefully considered when assessing the temporal stability of the subject airmass.

Radiosonde observations for 1200 GMT were available from sites near each of the flight tracks. At some locations radiosonde data for 0000 GMT and/or 0600 GMT were also available. The temperatures from the radiosonde station closest in time and location to each flight track have been plotted on the temperature plots in Fig. 6-2. The relative humidities, computed from RAOB temperature and dewpoint depression measurements are also shown on the plots in Fig. 6-3. The locations of the radiosonde stations are shown on the data site detail maps in Fig. 1-1. More detailed location information as well as the station identification code used in Fig. 6-2 and 6-3 is included in Table 6.2. Although the RAOB data are graphed with the C-130 data, it should be remembered that the two data sets are often remote in either space or time. Weather and traffic conditions often induce three to four miles of variability in the location of each day's flight track. Thus only approximate track-RAOB geographical separations are indicated in the flight descriptions of Section 7.3 and in Table 6.2. The time separations may be determined by comparing the flight times noted in Tables 6.1 and 7.3 with the RAOB release time noted in Table 6.2.

**Table 6.1. Flight Profile Elapsed Time Summary (GMT)**

Flight No.	Date (1977)	Profile Flight Times (GMT)								Total Time Elapsed (V-PRO Only)	
		Filter 2		Filter 4		Filter 3		Filter 5		Hours	Minutes
		Start	Stop	Start	Stop	Start	Stop	Start	Stop		
C-410	4 Jul	1134	1213	1309	1402	1232	1249	1420	1432	2	58
C-411	6 Jul	0912	0935	1017	1043	0952	0959	1103	1113	2	1
C-412	7 Jul	0900	1003	1056	1159	1021	1036	1219	1233	3	33
C-413	27 Jul	1543	1603	1458	1517	1441	1455	1525	1540	1	22
C-414	28 Jul	1059	1110	1024	1032	1040	1059	1117	1136	1	12
C-415	29 Jul	1137	1141	1044	1047	1204	1207	1118	1123	1	23
C-416	1 Aug	1139	1239	1402	1432	1258	1312	1434	1450	3	11
C-418	4 Aug	0847	0905	0910	0930	0930	0949	0953	1008	1	21
C-419	4 Aug	1449	1451	1538	1543	1513	1518	1603	1608	1	19
C-420	5 Aug	0855	0930	1015	1051	0946	0957	1110	1119	2	24
C-421	10 Aug	1025	1134	1233	1338	1155	1210	1354	1412	3	47
C-422	11 Aug	1011	1017	1054	1100	1034	1040	1113	1120	1	9

**Table 6.2. Radiosonde Station Identification**

Flight No.	Track Identification	Radiosonde Station	Range and Direction from Track Center	Fig. 6-1 & 6-2 Identification Code	RAOB Time
C-410	Bruz	Brest	208 Km WNW	RAOB B	0000
C-411	Bruz	Brest	208 Km WNW	RAOB B	1200
C-412	Bruz	Brest	208 Km WNW	RAOB B	1200
C-413	Rodby	Schleswig	103 Km W	RAOB S	1200
C-414	Ahlhorn	Rheine/Waldhugel	73 Km S	RAOB R	1200
C-415	Meppen	Rheine/Waldhugel	82 Km S	RAOB R	1200
C-416	Rodby	Schleswig	103 Km W	RAOB S	1200
C-418	Ahlhorn	Rheine/Waldhugel	73 Km S	RAOB R	1200
C-419	Meppen	Rheine/Waldhugel	82 Km S	RAOB R	1200
C-420	Meppen	Rheine/Waldhugel	82 Km S	RAOB R	1200
C-421	Rodby	Schleswig	103 Km W	RAOB S	1200
C-422	Rodby	Schleswig	103 Km W	RAOB S	1200

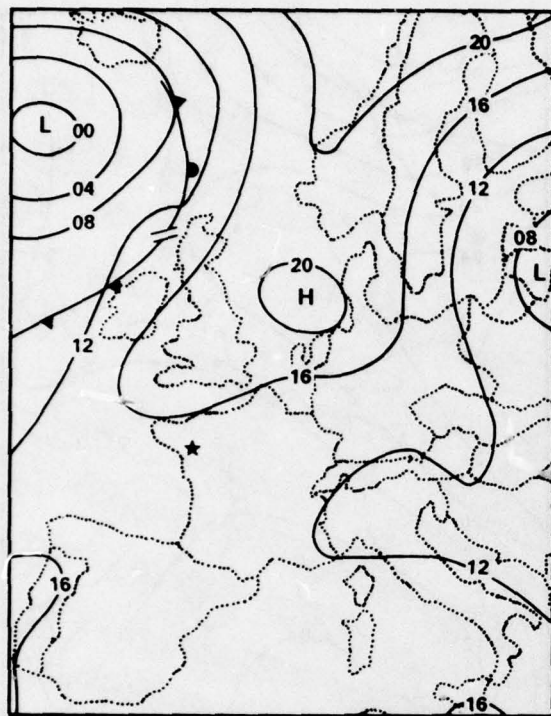

4 JULY 1977 0000 GMT

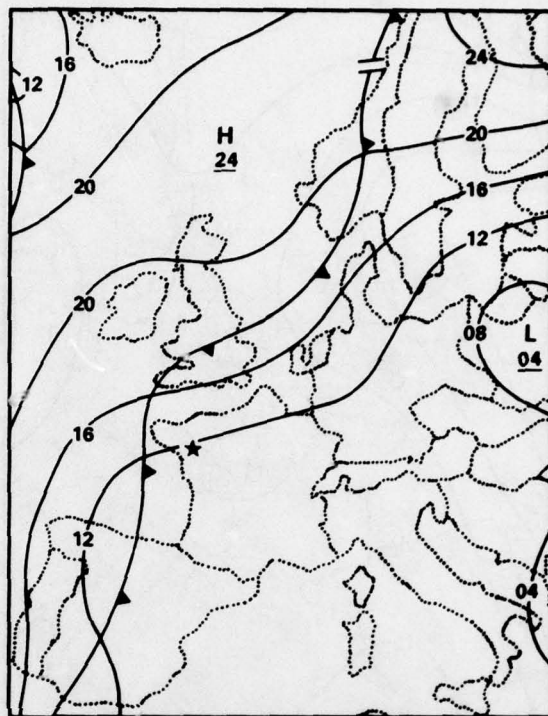

6 JULY 1977 1200 GMT

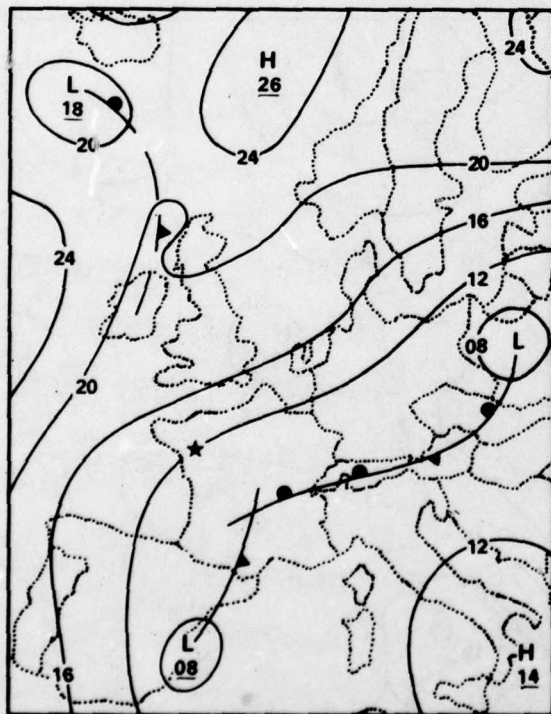

7 JULY 1977 1200 GMT

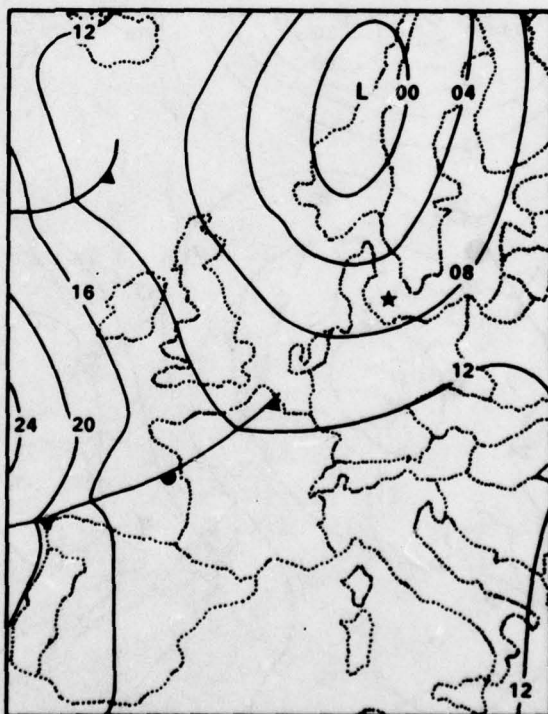

27 JULY 1977 1200 GMT

Fig. 6-1. Synoptic Surface Charts of European Area During Project OPAQUE III

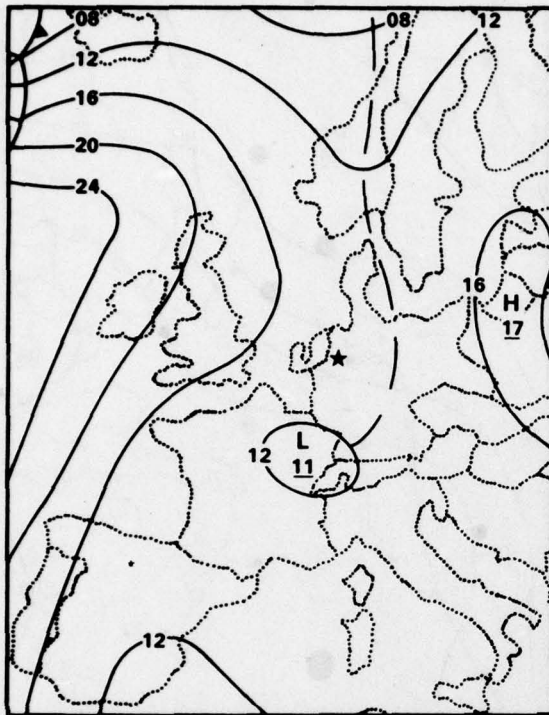

28 JULY 1977 1200 GMT

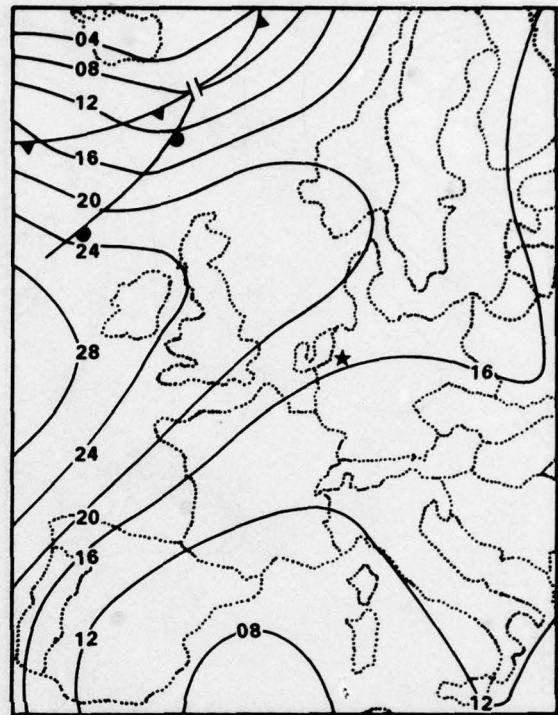

29 JULY 1977 1200 GMT

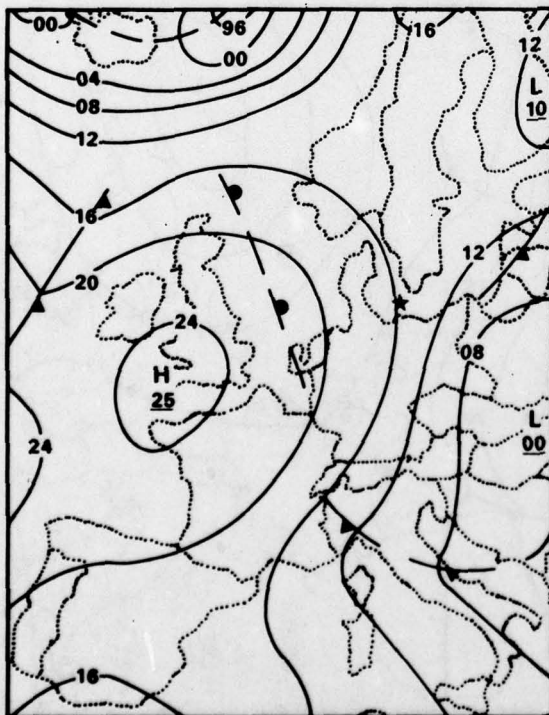

1 AUGUST 1977 1200 GMT

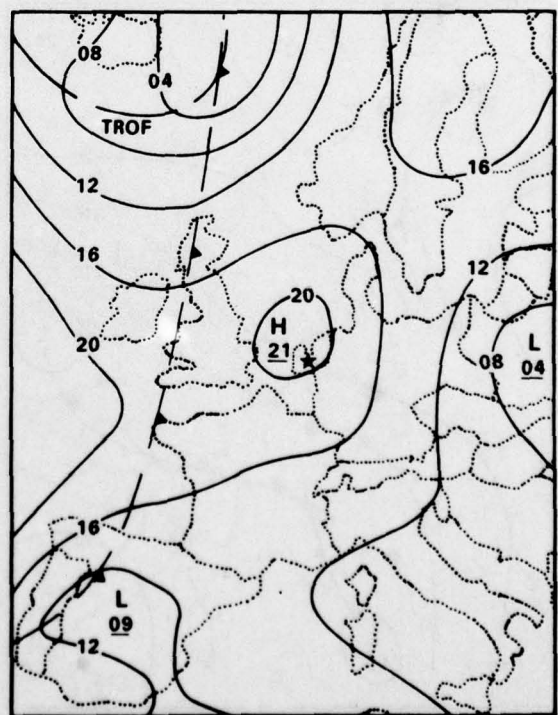

4 AUGUST 1977 0600 GMT

Fig. 6-1 (cont). Synoptic Surface Charts of European Area During Project OPAQUE III.

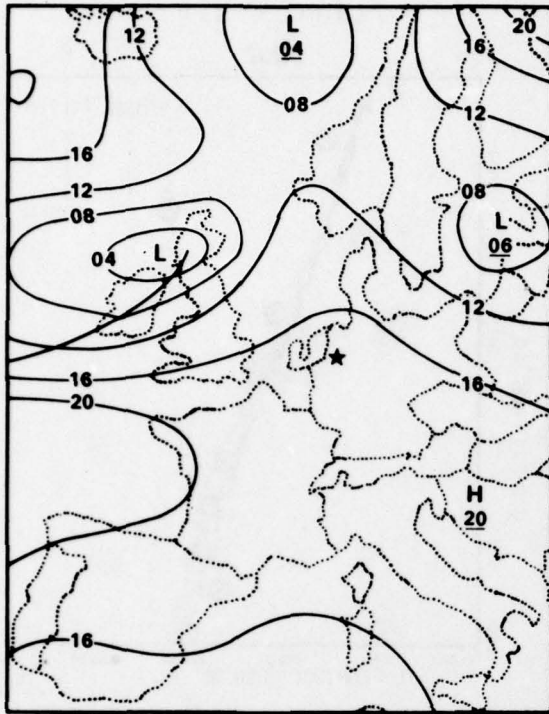

4 AUGUST 1977 1200 GMT

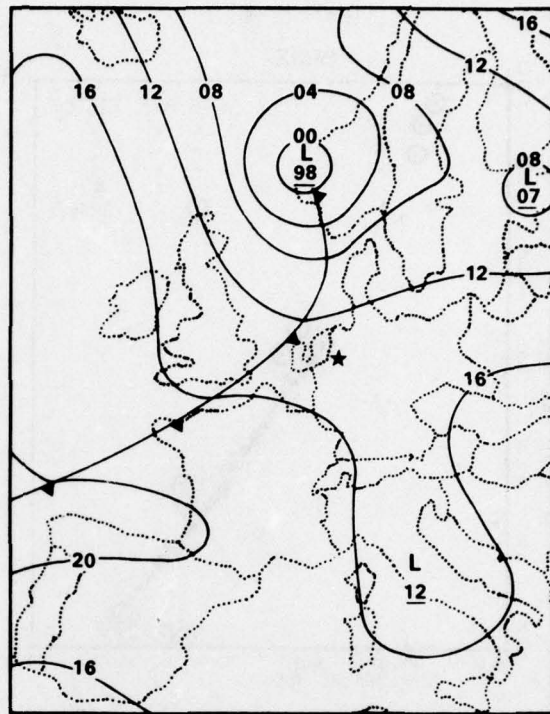

5 AUGUST 1977 0600 GMT

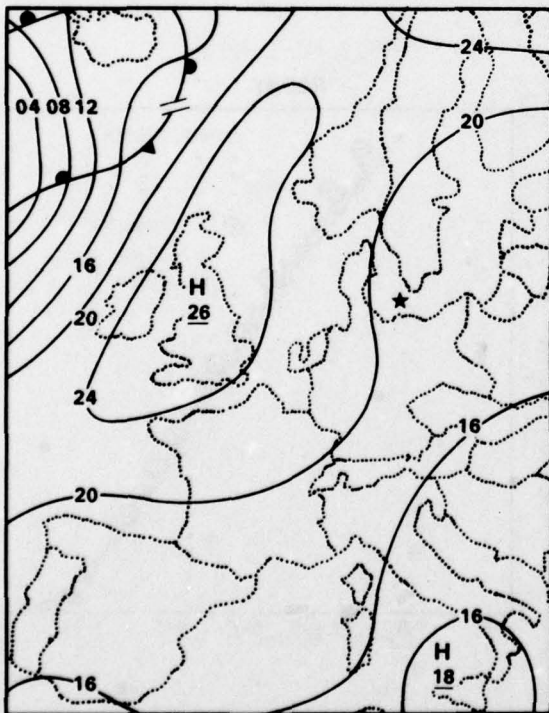

10 AUGUST 1977 1200 GMT

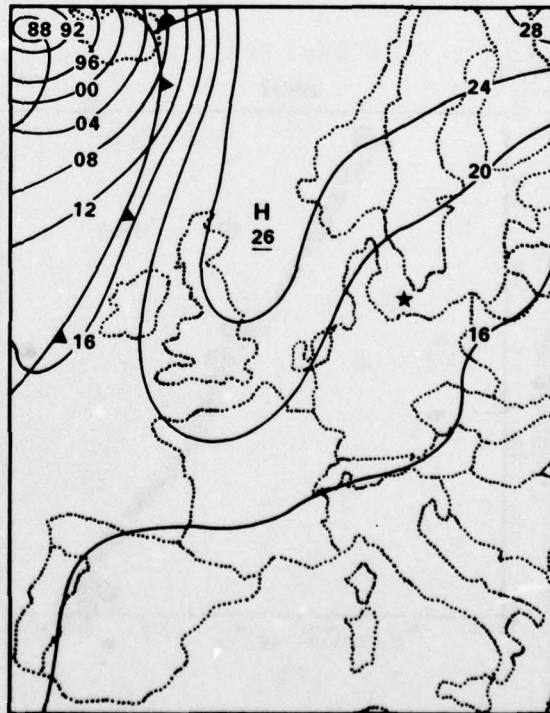

11 AUGUST 1977 1200 GMT

Fig. 6-1 (cont). Synoptic Surface Charts of European Area During Project OPAQUE III.

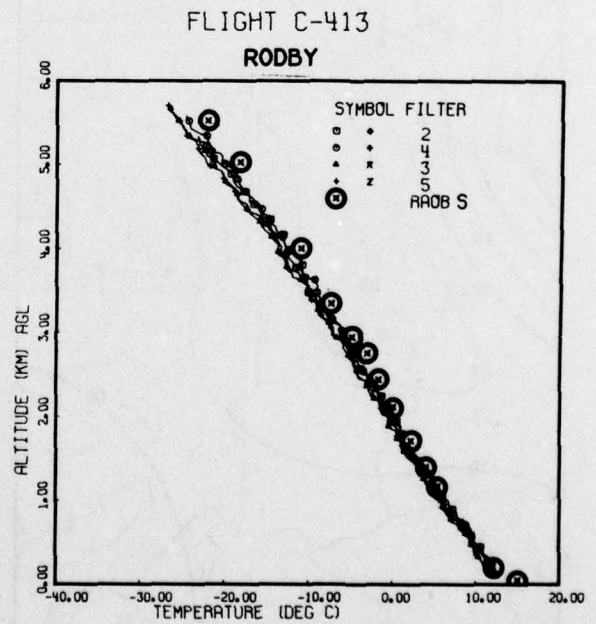
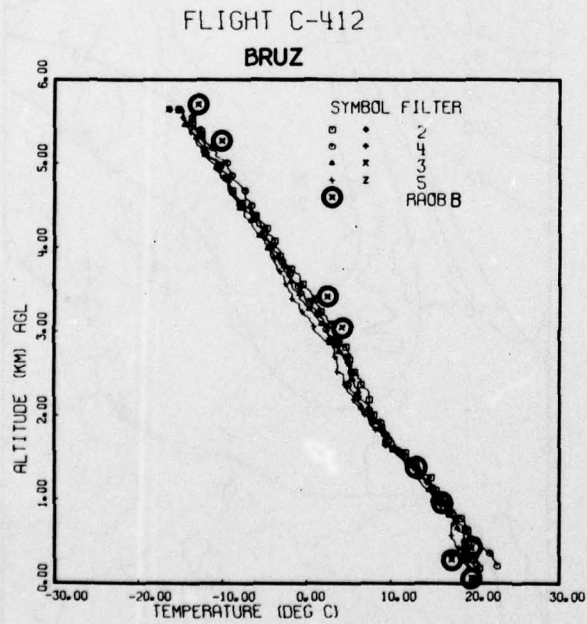
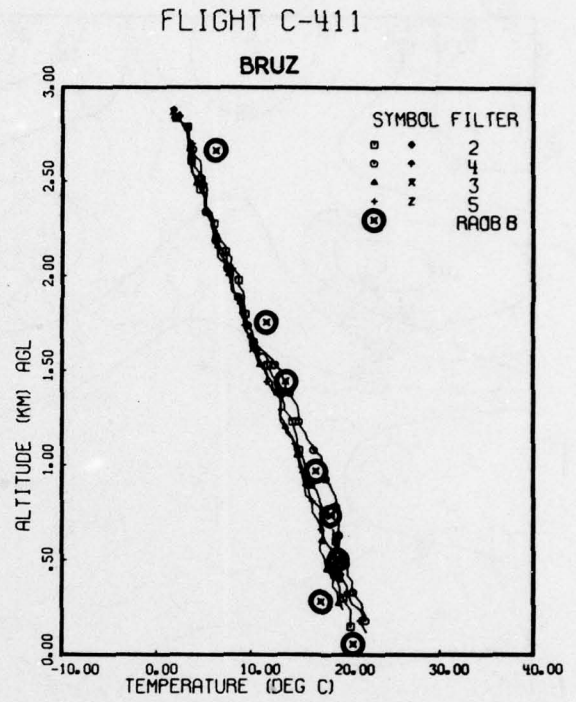
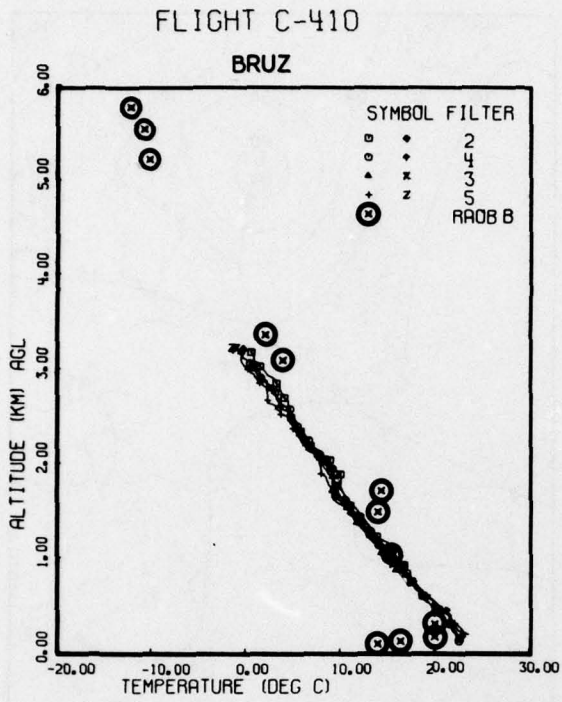

Fig. 6-2. Temperature Versus Altitude for Twelve Project OPAQUE III Flights.

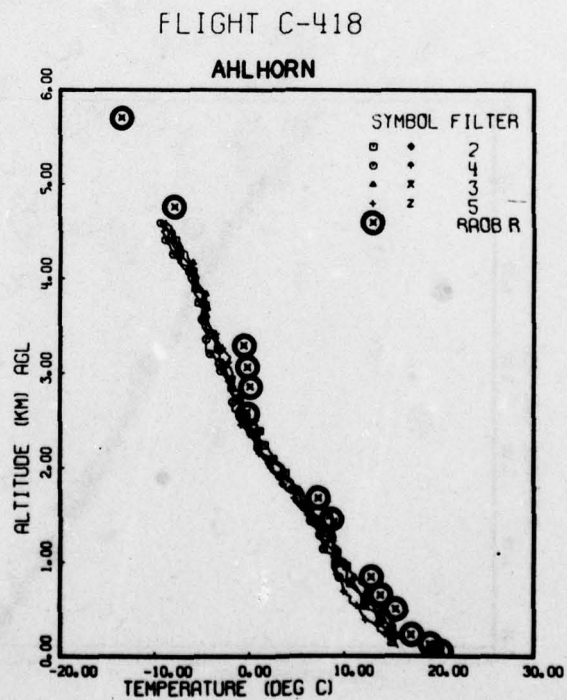
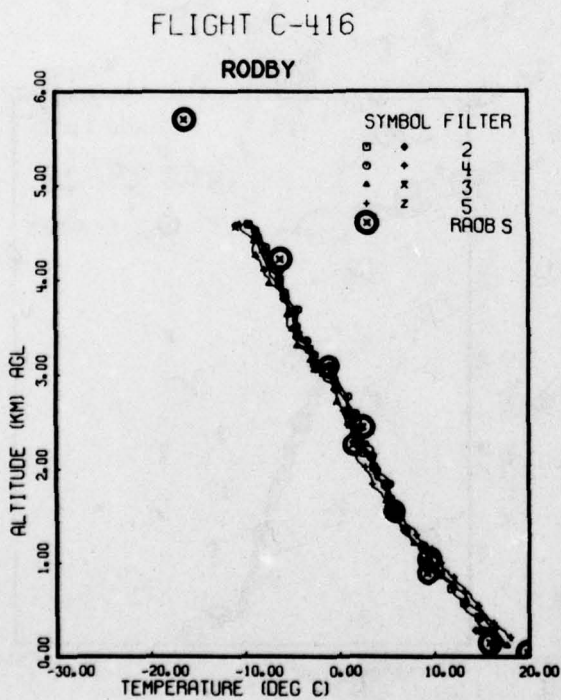
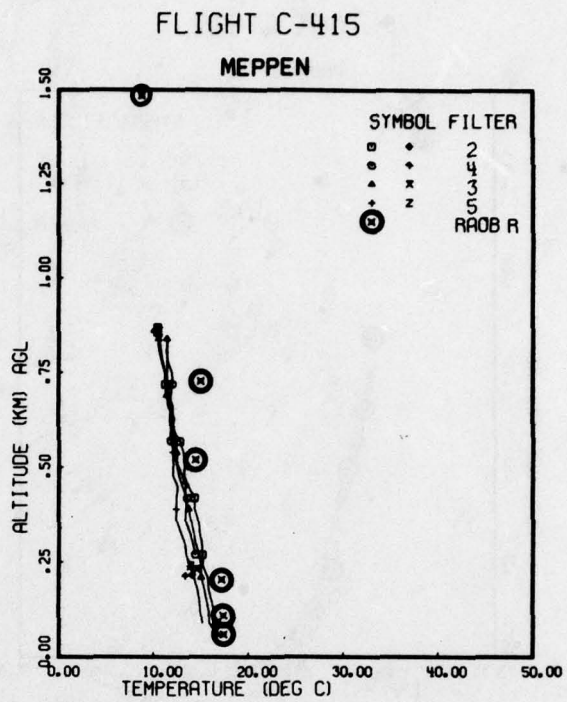
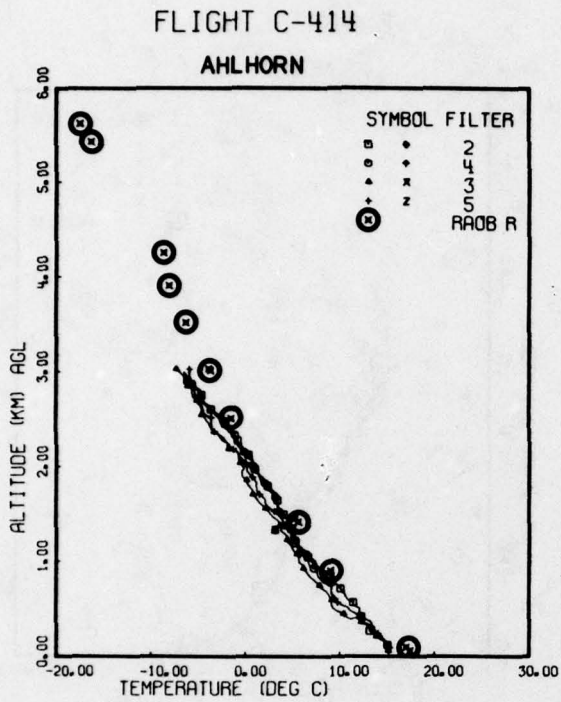

Fig. 6-2 (cont). Temperature Versus Altitude for Twelve Project OPAQUE III Flights.

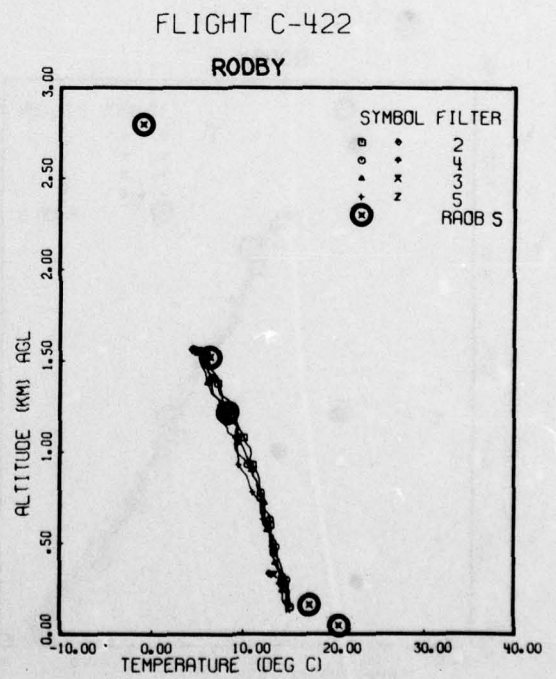
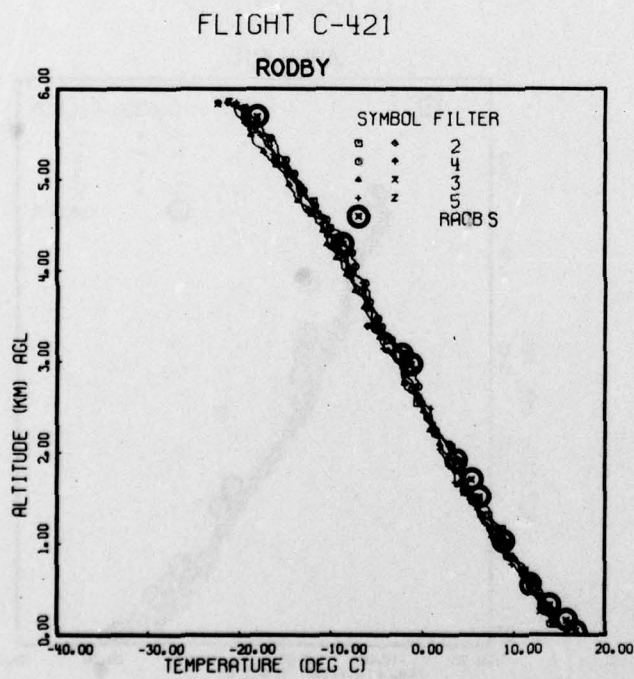
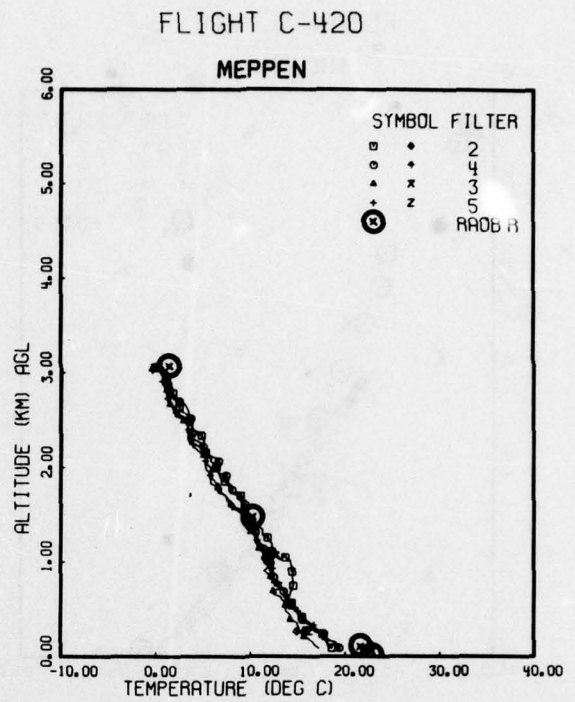
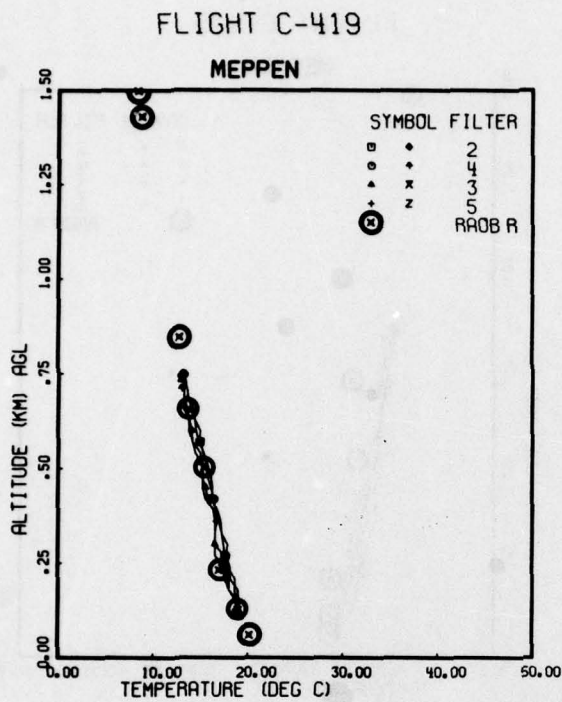
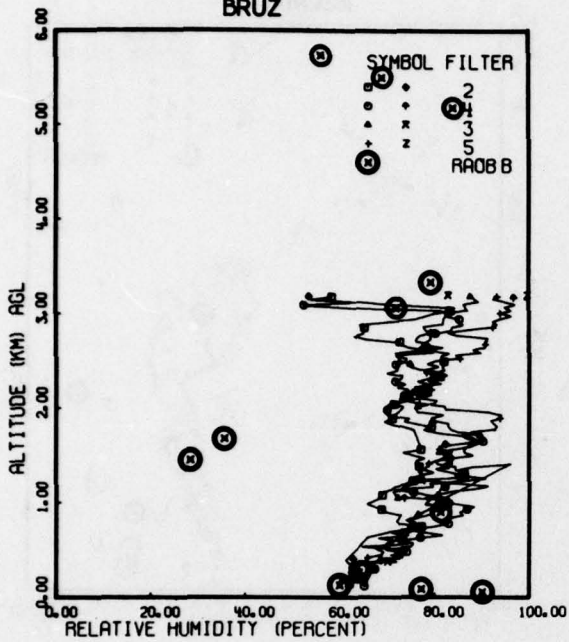

Fig. 6-2 (cont). Temperature Versus Altitude for Twelve Project OPAQUE III Flights.

FLIGHT C-410

BRUZ



FLIGHT C-411

BRUZ

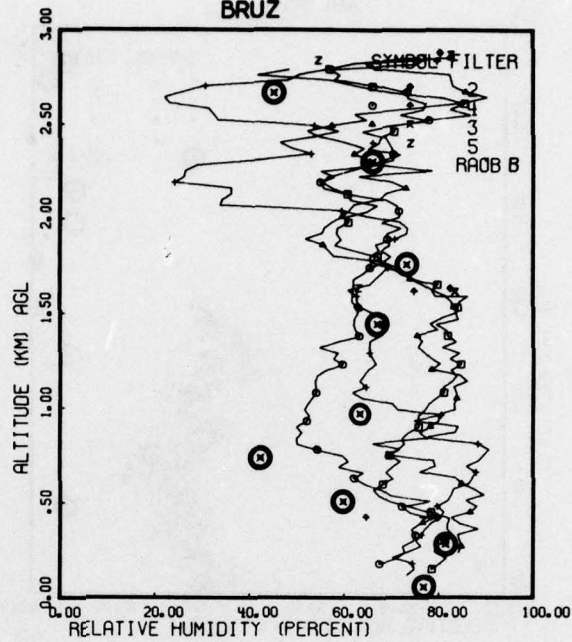

FLIGHT C-412

BRUZ

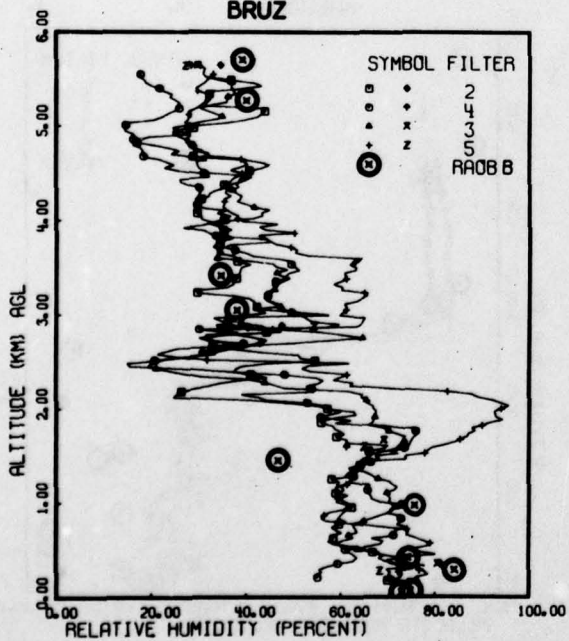

FLIGHT C-413

RODBY

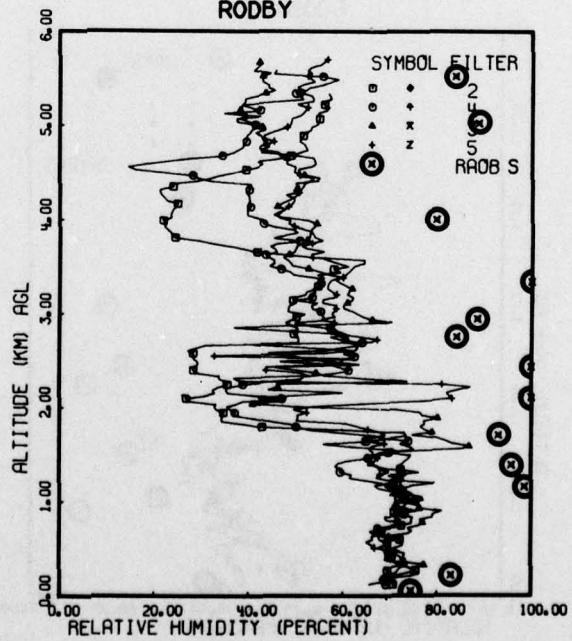
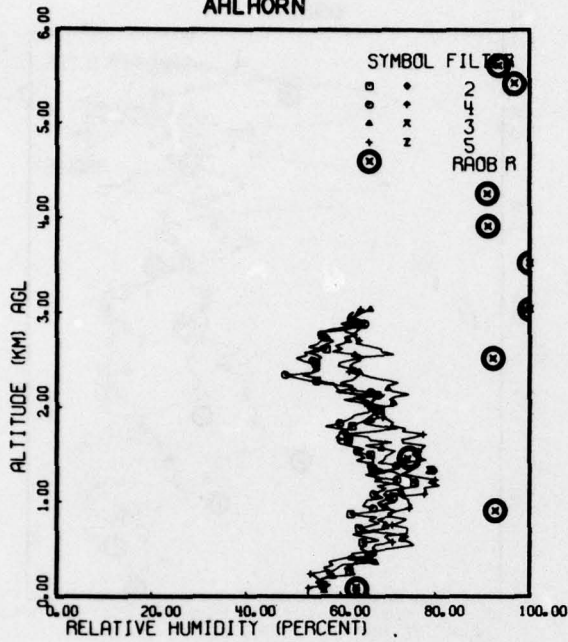

Fig. 6-3. Relative Humidity Versus Altitude for Twelve Project OPAQUE III Flights.

FLIGHT C-414

AHLHORN



FLIGHT C-415

MEPPEN

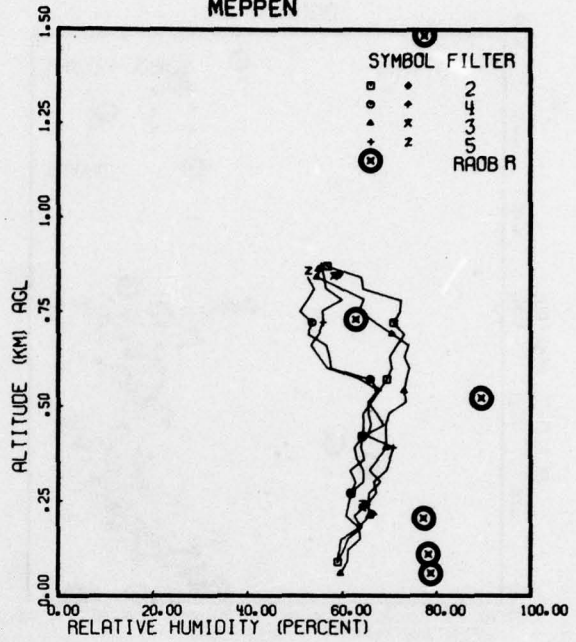

FLIGHT C-416

RODBY

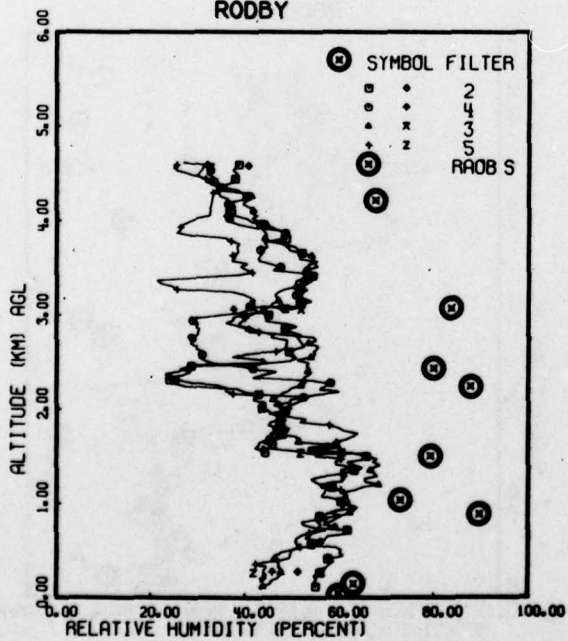

FLIGHT C-418

AHLHORN

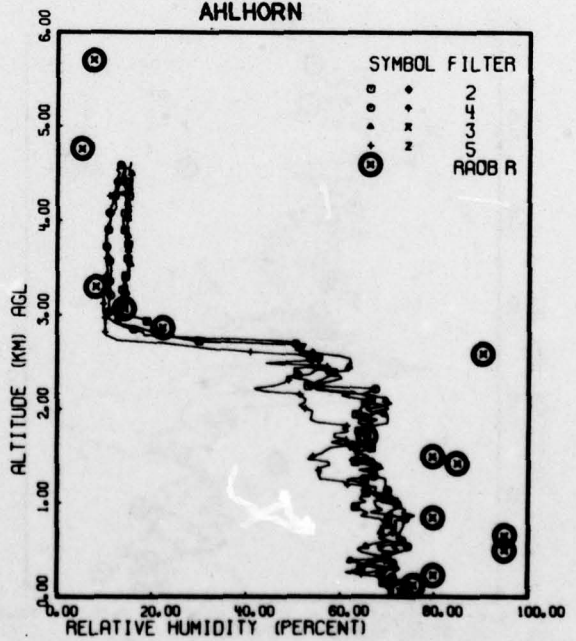
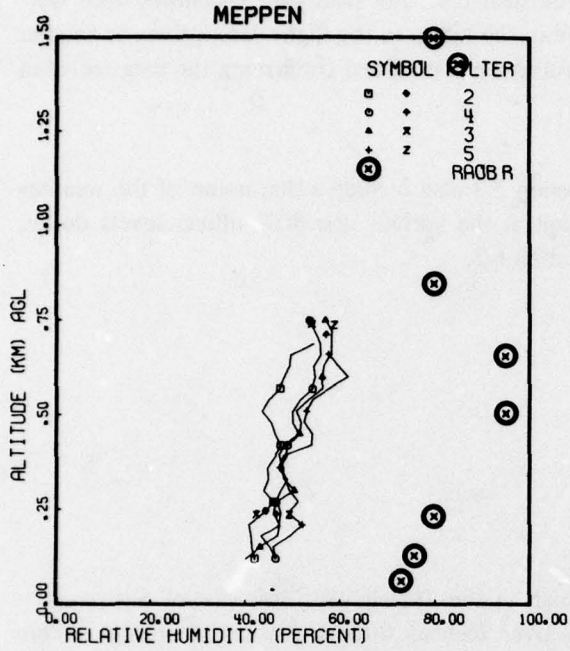
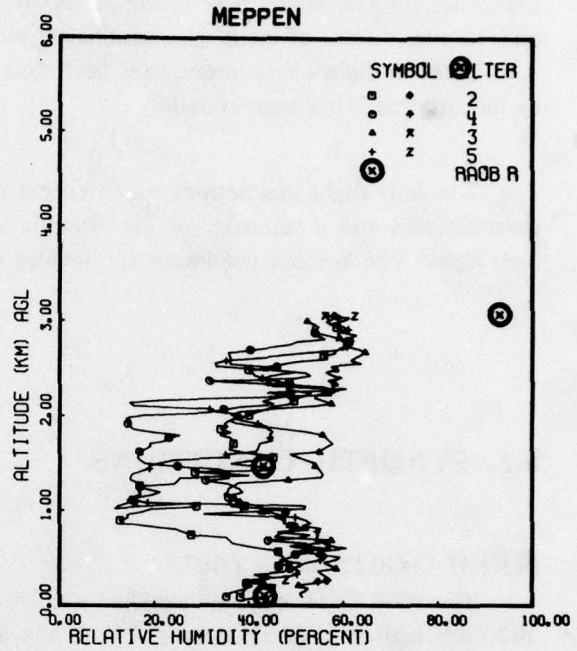

Fig. 6-3 (cont). Relative Humidity Versus Altitude for Twelve Project OPAQUE III Flights.

FLIGHT C-419



FLIGHT C-420



FLIGHT C-421

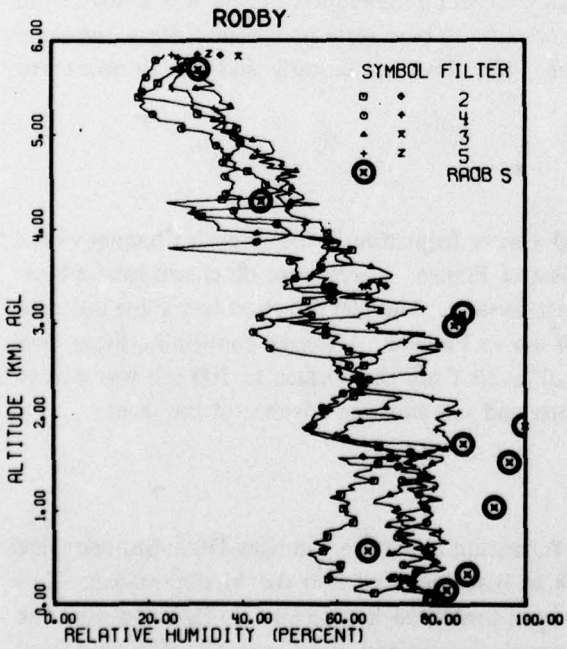

FLIGHT C-422

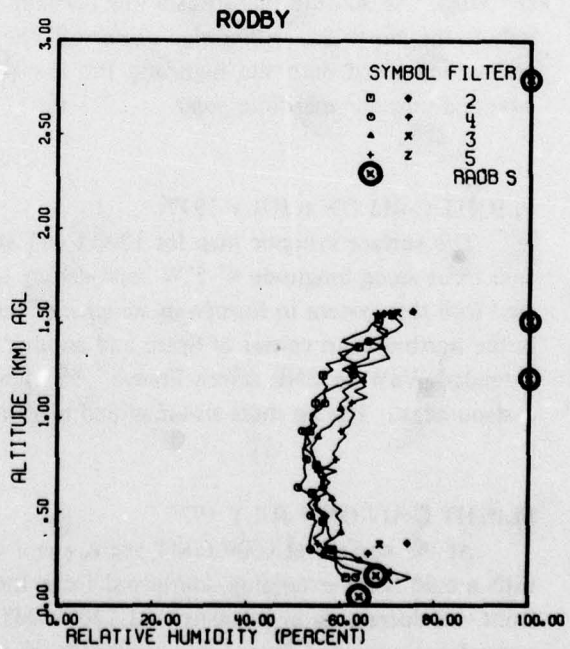

Fig. 6-3 (cont). Relative Humidity Versus Altitude for Twelve Project OPAQUE III Flights.

During each of the flights an on-board meteorologist made and recorded observations concerning the cloud and haze conditions, shadows, visibility of the solar disc, and slant path visibilities from various altitudes. Some of these observations are included in the tables in the flight descriptions in Section 7.3. These in-flight observations have been very useful in evaluating and confirming the data recorded by the airborne instrument systems.

The daily flight descriptions which appear in Section 7.3 also include a discussion of the weather characteristics and a summary of the synoptic situation at the surface and 500-millibar levels during each flight. The synoptic conditions are detailed in Section 6.2.

## **6.2. SYNOPTIC CONDITIONS**

### **FLIGHT C-410 ON 4 JULY 1977**

The 0000 GMT surface chart had a 1016 mb high in the Tyrrhenian Sea, east of Sicily, and a 1021 mb high east of Denmark. There was a low over Iceland with an associated frontal system extending southward. Over France there was weak pressure gradient with a col off the coast. At 1200 GMT the high east of Denmark had built to 1024 mb. Most of France was in a col with pressures about 1014 mb. The low south of Iceland was weakening slightly with the frontal system still west of 10° West. At 500 mb there was a low pressure trough over southern France. There was a ridge from Italy to the North Sea with a high center off The Netherlands. There were no closed centers, the same contour enclosed both the high and the low pressure. The flow was easterly and the air mass was modified unstable maritime polar.

### **FLIGHT C-411 ON 6 JULY 1977**

The surface synoptic map for 1200 GMT showed a wave formation in the English Channel with a cold front along longitude 4°-5°W approaching the coast of France. There were no closed lows associated with this system in Europe in advance of the frontal system. The 500 mb chart had a low centered in the northwestern corner of Spain and another small low in Finland. A trough connecting these lows extended WSW to ENE across France. The flow at all levels from the surface to 500 mb was east to eastsoutheast. The air mass was modified maritime polar and was stable in advance of the front.

### **FLIGHT C-412 ON 7 JULY 1977**

At the surface at 0000 GMT there was a wave formation along the Limoges-Dijon-Stuttgart line with a cold front extending southward from Limoges to Barcelona and into the Mediterranean. This front was decreasing in intensity. At 1200 GMT the wave formation had moved slowly eastward. The warm front extended from Lyon eastnortheastward through Switzerland into Germany. The cold front part of this system extended along a line from Lyon-Ibiza-Balearic Islands. This frontal system was in a trough without closed isobars. The 500 mb chart showed very little change from 24 hours ago. One

low was located in the central part of northwestern Spain. The other low, in Finland, had remained stationary and decreased in intensity. The track, as well as all of France, was in the trough between the two lows. The flow at all levels from the surface to 500 mb was easterly. The RAOB station at Brest was WNW of the track. The air mass was modified unstable maritime polar.

#### FLIGHT C-413 ON 27 JULY 1977

The surface chart for 0000 GMT had a 997 mb low centered near Bergen. There was no front from the center but a cold front was located between Ireland and Britain and then westward into the Atlantic. At 1200 GMT the low was stationary over Bergen and had filled to 999 mb. An occluded front extended from central Belgium southsouthwestward through France to the Bay of Biscay. At 500 mb a large closed low was located over the North Sea west of Bergen. With lows at the surface and 500 mb cold moist air was being advected into the area at all levels. The air mass was unstable maritime polar.

#### FLIGHT C-414 ON 28 JULY 1977

The surface chart for 0000 GMT had a dissipating cold front through southern Belgium, southern France, and central Spain. There was a filling low north of the Arctic Circle at 71°N 10°E. At 1200 GMT there were no fronts depicted in Europe. There was a 1012 mb closed low in eastern France. The flight track was in a col. A trough east of the track was on a line from Hamburg to Stuttgart. At 500 mb there was a low at 62°N 9°E and another low near Brest. Over northern Germany between the two lows there was light southsouthwesterly flow. The air mass was modified unstable maritime polar.

#### FLIGHT C-415 ON 29 JULY 1977

The 0000 GMT surface chart had a 1013 mb open low centered near Karlsruhe with a trough through central Germany to the Balearics. The Atlantic high centered at 43°N 30°W had a ridge from Britain to Scandinavia with a 1019 mb high near Göteborg, Sweden. At 1200 GMT the trough had pushed slightly farther north and the high cell over Göteborg was gone. At the same time the ridge had weakened slightly. The 500 mb chart showed a low over southwestern France. There was a ridge from the Azores to Scotland and another ridge from the Adriatic to the tip of Sweden. Another low area was centered at 53°N 30°E. The track was in an area of weak pressure gradients in the midst of these four systems, in other words, the area was in a col. The air mass was stable maritime polar.

#### FLIGHT C-416 ON 1 AUGUST 1977

At 0000 GMT there was a 1000 mb low over Hungary. A cold front extended from Yugoslavia through northern Italy and then northwestward as a warm front through Belgium and along the east coast of Britain then as a cold front southsouthwestward under the center of the Atlantic High. The warm front part of this storm system was 10° west of the Rodby track. Ridging from the Atlantic high extended through northern Britain to Scandinavia. At 1200 GMT the frontal system was dissipating and extended along a line through central Yugoslavia, north central Italy, then northwest into central Belgium and the North Sea. Ridging from the Atlantic High continued through Scandinavia with a

closed 1025 mb high in southwestern Britain. At 500 mb there was a low system in southeastern Germany that extended over the flight track. In addition, there was a ridge from Spain to Britain. The flow was northeasterly and the air mass was unstable maritime polar.

#### FLIGHT C-418 ON 4 AUGUST 1977

At 0000 GMT there was weak ridging from the Atlantic High covering Europe and bringing moisture at low levels. At 1200 GMT the ridging continued with a weak gradient across western Europe. A cold front was approaching the Irish coast. At 500 mb there was an open low in eastern Spain with a trough south to Algiers. There was slight ridging through western Germany, Netherlands, and Denmark. The flow was westerly and the air mass was unstable maritime polar at low levels.

#### FLIGHT C-419 ON 4 AUGUST 1977

The synoptic conditions are the same as for Flight C-418 which was on the morning of the same day.

#### FLIGHT C-420 ON 5 AUGUST 1977

At 0000 GMT there was a weak ridge of high pressure over western Europe. The gradient was weak with a cold front approaching the coast of Britain. At 1200 GMT the cold front extended along a line from Bergen to London to Brest and then into the Atlantic. There was an open low over Rome with a weak trough northnorthwest to the North Sea. The 500 mb chart had a low over Iceland with a trough southeast to Britain. There was a weak ridge from western Germany to Sweden. The flow was southwesterly and the air mass was modified stable maritime polar.

#### FLIGHT C-421 ON 10 AUGUST 1977

At 0000 GMT a 1025 mb high was centered over the Irish Sea. A weakening low was centered over Madrid. There was a weak gradient over all of western Europe and an absence of frontal systems. At 1200 GMT the 1026 mb high was centered in the northern part of the Irish Sea. There was generally high pressure over all of Europe with a weak gradient. At 500 mb there was a low over the North Sea with a trough southward to Italy. The low center was five degrees west of the track. The flow was from the south to southwest and the air mass was unstable maritime polar.

#### FLIGHT C-422 ON 11 AUGUST 1977

At 0000 GMT there was a high over the North Pole with a ridge southward through Scandinavia to France. There was a low south of Iceland with a cold front southward along 17.5°W. At 1200 GMT ridging continued with the axis through eastern Great Britain. Moist air at low levels was being advected from the North Sea. At 500 mb there was a low centered near Frankfurt. The flow was southeasterly and the air mass was modified maritime polar.

### 6.3. TABULAR SUMMARY AND GLOSSARY

A summary of the daily meteorological observations taken at the weather stations nearest each flight track on the days during which data flights were made is presented in Table 6.3. A glossary of the most often used symbols is also included. All data were reported in Greenwich Civil Time (GCT) which is equivalent to Greenwich Mean Time (GMT), the terminology used in Table 6.3.

Also included in this section in Fig. 6-4 are portions of satellite maps showing the European area and its cloud cover. Table 6.4 lists the flights and conditions over each of the tracks showing that in almost every case the track flown was the most appropriate for the date. In some instances when the aircraft was deployed in Germany the track in France would have been a better choice but the distance was too far from the staging area to permit utilization.

Table 6.3. Standard Meteorological Data Sheet

Flight No. C-410		Field Site: Bruz						
Date: 4 July 1977		Lat. 48°01'N Long. 1°41'W El. 46m						
Time GMT	Sky and Ceiling (Hundreds of Feet)	Visibility (Kilometers)	Weather and Obstructions To Vision	Temp. (°C)	Dewpoint (°C)	Direction (00-36)	Wind Speed (mps)	Remarks
BRIST (071100) 48°27'N 4°25'W Elev. 99 m 208 km WNW of Track Center								
0900	100☉	8.0		20.2	15.2	04	3.6	1/8 Ac
1000	100☉	8.0		22.2	16.2	02	3.0	3/8 Ac
1200	40☉	12.0		26.2	18.2	08	3.1	1/8 Cu
1300	40☉	11.2		26.2	19.2	04	4.6	1/8 Cu
1400	43☉	11.2		26.2	19.2	04	4.6	2/8 Cu
1500	43☉	12.0		26.2	19.2	02	5.7	3/8 Cu 4/8 Cb
RENNES/ST. JACQUES (071300) 48°4'N 1°44'W Elev. 37m 7 Km North of Center of Track								
0900	80☉	20.0		23.0	16.0	24	1.5	1/8 Cu
1200	40☉ E100☉	20.0		28.0	17.0	02	2.6	1/8 Cu 5/8 As
1300	46☉ 100☉	11.2		29.0	16.0	08	2.5	2/8 Cu 3/8 As
1400	33☉ 46☉	11.2		28.0	16.0	08	3.6	1/8 Cu 4/8 As
1500	30☉ 40☉ 200☉	15.0		27.0	17.0	16	3.1	3/8 Cb 4/8 As 7/8 Ci
ST. NAZAIRE/MONTOIR (072170) 47°19'N 2°10'W Elev. 3m 86 km SSW of Track Center								
0900	130☉ 200☉	10.0		23.0	19.0	12	1.0	2/8 Ac 3/8 Ci
1200	43☉ 100☉	15.0		27.0	17.0	10	3.1	1/8 Cu 3/8 Ac
1300	48☉ 100☉	11.2		26.0	19.0	16	2.5	2/8 Cu 3/8 As
1400	41☉ E80☉	11.2		25.0	19.0	18	4.1	3/8 Cu 7/8 As
1500	40☉ E100☉	15.0		24.0	18.0	20	3.1	1/8 Cu 6/8 As
NANTES/CHATEAU BOUGON (072220) 47°19'N 1°36'W Elev. 27m 78 Km South of Track Center								
0900	50☉ E100☉	20.0		23.0	19.0	00	00	1/8 Sc 5/8 Ac
1200	40☉ 100☉	25.0		26.0	19.0	10	1.0	1/8 Cu 3/8 Ac
1300	43☉ E110☉	11.2		27.0	19.0	04	2.0	4/8 Cu 6/8 Ac
1400	46☉ E100☉	11.2		27.0	19.0	02	1.0	4/8 Cu 6/8 Ac
1500	46☉ E100☉	20.0		26.0	19.0	02	2.1	4/8 Cu 7/8 Ac
ANBERS/AVRILLE (072300) 47°30'N 0°34'W Elev. 57m 107 Km SE of Track Center								
1200	E23☉ 100☉ 220☉	20.0		24.0	18.0	06	1.0	5/8 Sc 7/8 Ac 8/8 Cs
1500	20☉ 100☉	30.0		25.0	18.0	04	1.0	1/8 Cb 2/8 Ac

Flight No. C-411		Field Site: Bruz						
Date: 6 July 1977		Lat. 48°01'N Long. 1°41'W El. 46m						
Time GMT	Sky and Ceiling (Hundreds of Feet)	Visibility (Kilometers)	Weather and Obstructions To Vision	Temp. (°C)	Dewpoint (°C)	Direction (00-36)	Wind Speed (mps)	Remarks
BRIST (071100) 48°27'N 4°25'W Elev. 99m 208 Km WNW of Track Center								
0900	E100☉	3.8	F-	17.2	15.2	04	4.1	7/8 Ac
0900	100☉	4.0	F-	17.2	16.2	04	5.1	3/8 Ac
0900	110☉	5.0		20.2	16.2	04	5.6	4/8 Ac
1100	E110☉	5.0		21.2	17.2	06	5.6	6/8 Ac
1200	E100☉	5.0		20.2	17.2	04	6.2	7/8 Ac
RENNES/ST. JACQUES (071300) 48°4'N 1°44'W Elev. 37m 7 Km North of Track Center								
0900	E100☉	1.2	F-	20.0	17.0	34	2.0	6/8 Ac
0900	100☉ E100☉	2.0	F-	22.0	18.0	30	2.1	4/8 Ac 6/8 Ci
0900	100☉ E120☉	5.0		24.0	18.0	02	1.0	2/8 Ac 6/8 Ci
1100	110☉ 210☉	6.0		25.0	19.0	02	3.0	1/8 Cu 4/8 Ci
1300	110☉ 40☉ 210☉	6.0		27.0	19.0	36	1.5	2/8 Cu&Sc 3/8 Ac 5/8 Ci

## METEOROLOGICAL GLOSSARY AND ABBREVIATIONS

<b>SKY AND CEILING</b>	<b>VISIBILITY (VV)</b>																								
<p>Sky cover symbols are in ascending order. Figures preceding symbols are heights in hundreds of feet above station. Sky cover symbols are:</p> <ul style="list-style-type: none"> <li>○ Clear: less than 0.1 sky cover</li> <li>⊙ Scattered: 0.1 to less than 0.6 sky cover</li> <li>⊕ Broken: 0.6 to 0.9 sky cover</li> <li>⊖ Overcast: more than 0.9 sky cover               <ul style="list-style-type: none"> <li>- Thin (when prefixed); light (when suffixed)</li> <li>-- Very light (when suffixed)</li> </ul> </li> <li>-X Partial obscuration: 0.1 to less than 1.0 sky hidden by precipitation or obstruction to vision (bases at surface)</li> <li>X Obscuration: 1.0 sky hidden by precipitation or obstruction to vision (bases at surface)</li> </ul> <p>Letter preceding height of layer identifies ceiling layer and indicates how ceiling height was obtained. Thus:</p> <ul style="list-style-type: none"> <li>A Aircraft</li> <li>B Balloon (pilot or ceiling)</li> <li>D Estimated height of cirriform clouds on basis of persistency</li> <li>E Estimated height of noncirriform clouds</li> <li>M Measured</li> <li>R Radiosonde balloon or radar</li> <li>U Height of cirriform ceiling layer unknown</li> <li>V Immediately following numerical value indicates a varying ceiling (also used with varying visibility)</li> <li>W Indefinite, sky obscured by surface base phenomenon. e.g. fog, blowing dust, snow</li> </ul>	<p>Reported in kilometers.</p>																								
	<p><b>WEATHER AND OBSTRUCTION TO VISION SYMBOLS</b></p> <table style="width: 100%; border: none;"> <tr> <td style="width: 50%;">A Hail</td> <td style="width: 50%;">IF Ice fog</td> </tr> <tr> <td>AP Small hail</td> <td>K Smoke</td> </tr> <tr> <td>BD Blowing dust</td> <td>L Drizzle</td> </tr> <tr> <td>BN Blowing sand</td> <td>R Rain</td> </tr> <tr> <td>BS Blowing snow</td> <td>RW Rain showers</td> </tr> <tr> <td>D Dust</td> <td>S Snow</td> </tr> <tr> <td>E Sleet</td> <td>SG Snow grains</td> </tr> <tr> <td>EW Sleet showers</td> <td>SP Snow pellets</td> </tr> <tr> <td>F Fog</td> <td>SW Snow showers</td> </tr> <tr> <td>GF Ground fog</td> <td>T Thunderstorms</td> </tr> <tr> <td>H Haze</td> <td>ZL Freezing drizzle</td> </tr> <tr> <td>IC Ice crystals</td> <td>ZR Freezing rain</td> </tr> </table>	A Hail	IF Ice fog	AP Small hail	K Smoke	BD Blowing dust	L Drizzle	BN Blowing sand	R Rain	BS Blowing snow	RW Rain showers	D Dust	S Snow	E Sleet	SG Snow grains	EW Sleet showers	SP Snow pellets	F Fog	SW Snow showers	GF Ground fog	T Thunderstorms	H Haze	ZL Freezing drizzle	IC Ice crystals	ZR Freezing rain
A Hail	IF Ice fog																								
AP Small hail	K Smoke																								
BD Blowing dust	L Drizzle																								
BN Blowing sand	R Rain																								
BS Blowing snow	RW Rain showers																								
D Dust	S Snow																								
E Sleet	SG Snow grains																								
EW Sleet showers	SP Snow pellets																								
F Fog	SW Snow showers																								
GF Ground fog	T Thunderstorms																								
H Haze	ZL Freezing drizzle																								
IC Ice crystals	ZR Freezing rain																								
	<p><b>CLOUD ABBREVIATIONS</b></p> <table style="width: 100%; border: none;"> <tr> <td style="width: 50%;">Ac Altocumulus</td> <td style="width: 50%;">Cs Cirrostratus</td> </tr> <tr> <td>As Altostratus</td> <td>Cu Cumulus</td> </tr> <tr> <td>Cb Cumulonimbus</td> <td>Ns Nimbostratus</td> </tr> <tr> <td>Cc Cirrocumulus</td> <td>Sc Stratocumulus</td> </tr> <tr> <td>Ci Cirrus</td> <td>St Stratus</td> </tr> </table>	Ac Altocumulus	Cs Cirrostratus	As Altostratus	Cu Cumulus	Cb Cumulonimbus	Ns Nimbostratus	Cc Cirrocumulus	Sc Stratocumulus	Ci Cirrus	St Stratus														
Ac Altocumulus	Cs Cirrostratus																								
As Altostratus	Cu Cumulus																								
Cb Cumulonimbus	Ns Nimbostratus																								
Cc Cirrocumulus	Sc Stratocumulus																								
Ci Cirrus	St Stratus																								
	<p style="text-align: center;"><b>WIND</b></p> <p>Direction in ten's of degrees from true north, speed in meters per second (mps). A "0000" indicates calm. A "G" indicates gusty. A "Q" indicates squall. Peak speed of gusts, when reported, follows G or Q. The contraction WSHFT in remarks followed by time group (GMT) indicates wind shift and its time of occurrence.</p> <p style="text-align: center;">Examples: 0109 is 010 degrees, 9 mps. 3607G11 is 360 degrees, 7 mps, peak speed in gusts of 11 mps.</p>																								
<p><b>RELATIVE HUMIDITY (RH)</b></p> <p>Reported in percent and computed from temperature and dewpoint.</p>																									

Table 6.3. (Cont.) Standard Meteorological Data Sheet

Flight No. C-411 (cont)								Field Site: Bruz	
Date: 6 July 1977								Lat. 48°01'N Long. 1°41'W El. 46m	
Time GMT	Sky and Ceiling (Hundreds of Feet)	Visibility (Kilometers)	Weather and Obstructions To Vision		Temp. (°C)	Dewpoint (°C)	Wind		Remarks
							Direction (00-36)	Speed (mps)	
ST. NAZAIRE/MONITOR (072170) 47°19'N 2°10'W Elev. 3m 86 Km SSW of Track Center									
0800	260☉	6.0			22.0	19.0	04	2.0	1/8 Ci
0900	260☉	7.0			24.0	20.0	12	1.0	1/8 Ci
1000	30☉	9.0			26.0	20.0	04	2.5	1/8 Cu
1100	40☉	11.2			27.0	20.0	04	2.5	2/8 Cu
1200	43☉	10.0			29.0	20.0	02	3.1	4/8 Cu
NANTES/CHATEAU BOUGON (072220) 47°19'N 1°36'W Elev. 27m 78 Km South of Track Center									
0800	☉	5.0			23.0	19.0	10	2.0	0/8
0900	100☉	8.0			24.0	20.0	06	2.1	1/8 Ci
1000	30☉	9.9			26.0	21.0	36	2.0	2/8 Cu
1100	30☉	11.2			27.0	21.0	06	2.0	4/8 Cu
1200	E40☉	15.0			27.0	20.0	04	4.1	6/8 Cb
ANBERS/AVRILLE (072300) 47°30'N 0°34'W Elev. 57m 101 Km SE of Track Center									
0900	E100☉	8.0			22.0	19.0	02	1.0	5/8 Ac
1100	33☉	8.0			27.0	20.0	06	2.0	1/8 Cu
1200	40☉	15.0			29.0	19.0	06	2.1	3/8 Cu
Flight No. C-412								Field Site: Bruz	
Date: 7 July 1977								Lat. 48°01'N Long. 1°41'W El. 46m	
BREST (071100) 48°27'N 4°25'W Elev. 99m 208 Km WNW of Track Center									
0700	☉	6.0			16.2	14.2	06	7.2	0/8
0800	260☉	7.0			18.2	15.2	06	7.7	1/8 Ci
0900	260☉	8.0			19.2	14.2	04	7.7	1/8 Ci
1000	260☉	8.0			19.2	15.2	04	8.2	1/8 Ci
1100	☉	9.0			20.2	15.2	04	8.7	
1200	☉	9.0			20.2	15.2	04	8.8	
1300	☉	9.0			21.2	15.2	04	9.7	
RENNES/ST. JACQUES (071300) 48°4'N 1°44'W Elev. 37m 7 Km North of Track Center									
0700	250☉	6.0			20.0	17.0	34	1.5	2/8 Ci
0800	250☉	6.0			21.0	17.0	36	4.1	1/8 Ci
0900	250☉	6.0			22.0	18.0	36	4.6	1/8 Ci
1000	250☉	6.0			24.0	18.0	36	7.2	1/8 Ci
1100	30☉	7.0			25.0	18.0	36	6.1	1/8 Cu
1200	33☉	8.0			27.0	17.0	36	7.2	4/8 Cu
1300	36☉	9.0			27.0	16.0	02	6.6	2/8 Cu
ST. NAZAIRE/MONTOIR (072170) 47°19'N 2°10'W Elev. 3m 86 Km SSW of Track Center									
0700	58☉ E250☉	7.0			20.0	19.0	04	2.0	3/8 Ac 5/8 Ci
0800	E100☉ 250☉	8.0			21.0	19.0	02	3.6	5/8 Ac 6/8 Ci
0900	100☉ 250☉	8.0			23.0	20.0	36	6.2	3/8 Ac 7/8 Ci
1000	80☉	8.0			24.0	20.0	02	3.6	4/8 Ac
1100	40☉ E100☉	9.0			25.0	20.0	02	3.6	2/8 Cu 6/8 Ac
1200	43☉ E80☉	7.0			22.0	20.0	20	4.1	1/8 Cu 7/8 Ac
1300	40☉ 80☉	6.0			25.0	21.0	22	3.6	3/8 Cu 4/8 Ac
NANTES/CHATEAU BOUGON (072220) 47°19'N 1°36'W Elev. 27m 78 Km South of Track Center									
0700	E100☉	5.0			20.0	20.0	02	1.0	7/8 Ac
0800	E100☉	6.0			21.0	20.0	36	5.1	7/8 Ac
0900	E100☉	6.0			23.0	21.0	04	5.1	5/8 Ac
1000	E100☉	8.0			22.0	20.0	14	3.0	7/8 Ac
1100	E90☉	8.0			21.0	20.0	22	2.0	8/8 Ac Distant Thunder
1200	3☉ E90☉	5.0	TRW		22.0	20.0	14	2.1	3/8 Fs 8/8 As
1300	E30☉ 90☉	5.0	TRW		20.0	19.0	24	3.0	5/8 Cb 8/8 As
Flight No. C-413								Field Site: Rodby	
Date: 27 July 1977								Lat. 54°41'N Long. 11°08'E El. 0m	
KEGNAES (061190) 54°51'N 9°59'E Elev. 23m 76 Km WNW of Track Center									
1200	E21☉ 100☉	15.0	RW-		14.0	12.0	27	8.2	5/8 Cb 7/8 Ac
1500	21☉ 100☉	17.0			16.0	11.0	22	11.3	4/8 Cb 7/8 Ac
1800	24☉ 100☉	20.0			15.0	11.0	27	9.3	3/8 Cb 4/8 Ac
MON (061790) 54°57'N 12°33'E Elev. 15m 95 Km ENE of Track Center									
1200	E3☉ 100☉	12.0	RW-		-	-	23	9.3	6/8 Cb 7/8 Ac
1500	E3☉ 100☉	15.0			-	-	29	6.2	5/8 Cb 7/8 As
									Distant Lighting
1800	3☉ E100☉ 200☉	15.0			-	-	25	7.2	2/8 Cu 5/8 Ac 7/8 Ci
FEHMARNBELT (100060) 54°36'N 11°9'E Elev. 4m 9 Km South of Track Center									
1200	10☉ E100☉	20.0	RW-		16.0	13.0	22	10.3	4/8 Sc 8/8 Ac
1500	E10☉ 100☉	20.0			16.0	12.0	25	9.8	6/8 Sc 8/8 Ac
1800	10☉ E100☉ 200☉	20.0			17.0	13.0	27	10.8	1/8 Sc 5/8 Ac 6/8 Ci

**Table 6.3. (Cont.) Standard Meteorological Data Sheet**

Flight No. C-414		Date: 28 July 1977		Field Site: Ahlhorn		Lat. 52°53'N Long. 7°51'E El. 18m		
Time	Sky and Ceiling (Hundreds of Feet)	Visibility (Kilometers)	Weather and Obstructions To Vision	Temp (°C)	Dewpoint (°C)	Direction (00-36)	Speed (mps)	Remarks
EELDE (062800) 53°8'N 6°35'E Elev. 5m 89 Km WNW of Track Center								
0855	E30 100-☉	15.0		16.0	13.0	07	2.6	5/8 Cu 7/8 Ac
1000	30 40 E70 ☉	12.0		17.0	12.0	09	1.5	5/8 Cu 7/8 Ac
1100	20 E30 70 ☉	15.0		16.0	12.0	08	1.5	6/8 Cu 7/8 Ac
1200	20 25 E70 ☉	15.0		17.0	12.0	05	1.5	3/8 Cu 7/8 Ac
TWENTHE (062900) 52°16'N 6°54'E Elev. 35m 94 Km SW of Track Center								
0900	20 100-☉	7.0	H	17.0	12.0	14	1.5	1/8 Cu 4/8 Ac
1000	25 220-☉	8.0	H	17.0	11.0	18	1.0	3/8 Cu 5/8 Ac
1100	25 90-☉	8.0	F-	18.0	11.0	34	1.0	4/8 Cu 7/8 Ac
1200	25 E90 ☉	8.0	F-	18.0	12.0	08	1.5	3/8 Cu 7/8 Ac
MEPPEN (103040) 52°42'N 7°19'E Elev. 19m 40 Km SW of Track Center								
0844	10 E30 ☉	3.2	F-	15.0	12.0	00	0.0	7/8 Cu
0944	15 E30 ☉	4.0	H	16.0	12.0	00	0.0	7/8 Cu
1044	20 E40 ☉	7.0	H	17.0	11.0	00	0.0	6/8 Cu
1244	E25 ☉	9.0		20.0	10.0	11	2.0	5/8 Cu
LINGEN (103050) 52°31'N 7°19'E Elev. 21m 54 Km SW of Track Center								
0900	20 E60 ☉	5.0	H	15.0	11.0	16	0.5	2/8 Cu 6/8 Sc
1000	20 60 E250 ☉	10.0		17.0	12.0	14	0.5	3/8 Cu 3/8 Sc 6/8 Ci
1100	25 60 E250 ☉	10.0		17.0	11.0	07	0.5	3/8 Cu 3/8 Sc 7/8 Ci
1200	30 E250 ☉	15.0		19.0	10.0	09	1.5	3/8 Cu 6/8 Ci
1300	E50 ☉	18.0		19.0	11.0	-	-	6/8 Cu

Flight No. C-415		Date: 29 July 1977		Field Site: Meppen		Lat. 53°00'N Long. 7°37'E El. 18m		
Time	Sky and Ceiling (Hundreds of Feet)	Visibility (Kilometers)	Weather and Obstructions To Vision	Temp (°C)	Dewpoint (°C)	Direction (00-36)	Speed (mps)	Remarks
EELDE (062800) 58°8'N 6°35'E Elev. 5m 71 Km WNW of Track Center								
0925				16.0	12.0	03	6.1	
1000	50 E100 ☉	30.0		17.0	13.0	04	6.6	1/8 Cu 6/8 As
1100	20 E100 ☉	30.0		17.0	13.0	04	7.7	1/8 Cu 6/8 As
1200	25 E100 ☉	30.0		17.0	13.0	03	6.2	3/8 Cu 7/8 As
1300	25 E100 ☉	30.0		19.0	13.0	02	7.2	2/8 Cu 7/8 As
TWENTHE (062900) 52°16'N 6°54'E Elev. 35m 95 Km SW of Track Center								
1000	50 E70 90 ☉	8.0	R-	16.0	15.0	04	3.1	1/8 Cu 6/8 Sc 8/8 As
1100	E70 100 ☉	9.0		17.0	14.0	04	4.1	6/8 As 8/8 As
1200	60 E70 100 ☉	8.0		17.0	14.0	03	3.6	2/8 Sc 5/8 Sc 8/8 As
1300	60 E80 ☉	9.0	R-	17.0	15.0	04	3.1	4/8 Sc 8/8 As
MEPPEN (103040) 52°42'N 7°19'E Elev. 19m 39 Km SW of Track Center								
0944	50 E100 ☉	9.0		16.0	12.0	04	4.1	1/8 Cu 7/8 As
1044	50 E100 ☉	7.0	R-			04	3.6	3/8 Cu 7/8 As
1244	25 E50 ☉	7.0		17.0	13.0	01	5.6	4/8 Cu 6/8 Cu
LINGEN (103050) 52°31'N 7°19'E Elev. 21m 57 Km SW of Track Center								
1000	100 E150 ☉	13.0	R-	16.0	12.0	05	3.6	3/8 As 8/8 As
1100	50 E120 150 ☉	10.0	R-	17.0	12.0	05	3.6	3/8 Cu 5/8 As 8/8 Ac
1200	E35 50 120 ☉	10.0	R-	18.0	15.0	03	4.6	5/8 Cu 6/8 Sc 8/8 As
1300	35 E60 120 ☉	12.0	R-	18.0	15.0	04	3.6	2/8 Cu 5/8 Sc

Flight No. C-416		Date: 1 August 1977		Field Site: Rodby		Lat. 54°41'W Long. 11°8'E El. 0m		
Time	Sky and Ceiling (Hundreds of Feet)	Visibility (Kilometers)	Weather and Obstructions To Vision	Temp (°C)	Dewpoint (°C)	Direction (00-36)	Speed (mps)	Remarks
KEGNAES (061190) 54°51'N 9°59'E Elev. 23m 76 Km WNW of Track Center								
0900	☉	15.0		17.0	12.0	36	4.1	
1200	200 ☉	20.0		20.0	11.0	02	2.1	2/8 Ci
1500	200 ☉	20.0		22.0	11.0	34	4.1	4/8 Ci
SCHLESWIG (100350) 54°32'N 9°33'E Elev. 48m 103 Km W of Track Center								
1000	20 ☉	10.0		18.2	11.2	30	2.0	3/8 Cu
1100	20 ☉	12.0		20.2	11.2	35	3.5	3/8 Cu
1200	20 ☉	20.0		21.2	10.2	33	2.6	3/8 Cu
1300	21 ☉	25.0		22.2	12.2	34	3.6	3/8 Cu
1400	21 ☉	30.0		21.2	10.2	01	3.0	2/8 Cu
1500	23 200-☉	35.0		23.2	10.2	35	4.1	2/8 Cu 5/8 Ci
1600	23 200-☉	35.0		22.2	14.2	31	5.1	2/8 Cu 5/8 Ci
1700	25 200-☉	40.0		20.2	13.2	32	3.0	2/8 Cu 4/8 Ci

**Table 6.3. (Cont.) Standard Meteorological Data Sheet**

Flight No. C-416 (cont) Field Site: Rodby  
 Date: 1 August 1977 Lat. 54°41'W Long. 11°8'E El. 0m

Time GMT	Sky and Ceiling (Hundreds of Feet)	Visibility (Kilometers)	Weather and		Temp. (°C)	Dewpoint (°C)	Wind		Remarks
			Obstructions To Vision				Direction (00-36)	Speed (mps)	
MON (061790) 54°57'N 12°33'E Elev. 15m 95 Km NE of Track Center									
0900	9☉ 120☉ 200☉	18.0			-	-	36	5.1	1/8 Cu 2/8 As 6/8 Ci
1200	9☉ 200☉	18.0			-	-	36	4.1	1/8 Cu 5/8 Ci
1500	9☉ 200☉	18.0			-	-	02	2.1	1/8 Cu 6/8 Ci
FEHMARNBELT (100060) 54°36'N 11°9'E Elev. 4m 9 Km South of Track Center									
0900	15☉ 120☉ 200☉	20.0			17.0	15.0	36	7.2	1/8 Cu 2/8 As 3/8 Ci
1200	15☉ 120☉	20.0			18.0	15.0	34	6.2	1/8 Cu 3/8 As
1500	200☉	20.0			18.0	15.0	32	6.7	6/8 Ci

Flight No. C-418 Field Site: Ahlhorn  
 Date: 4 August 1977 Lat. 52°53'N Long. 7°51'E El. 18m

EELDE (062800) 53°8'N 6°35'E Elev. 5m 89 Km WNW of Track Center									
0900	10☉ 15☉	4.5	F-		18.0	15.0	28	1.5	1/8 Cu 4/8 Sc
1000	17☉	8.0	H		20.0	14.0	29	2.1	3/8 Cu
1100	20☉	8.0	H		21.0	14.0	09	1.0	3/8 Cu
1200	25☉ E250☉	8.0	H		21.0	14.0	29	3.1	3/8 Cu 5/8 Ci
TWENTHE (062900) 52°16'N 6°54'E Elev. 35m 94 Km SW of Track Center									
0900	7☉ E11☉ 50☉	2.2	F-		17.0	15.0	29	2.6	2/8 Fc 5/8 Fc 8/8 Sc
1000	10☉ 14☉	3.0	H		19.0	15.0	29	2.1	1/8 Fc 7/8 Sc
1100	18☉ 50☉	4.5	H		19.0	14.0	29	2.1	1/8 Cu 5/8 Sc
1200	25☉ 250☉	5.0	H		21.0	13.0	09	1.5	3/8 Cu 5/8 Ci
OLDENBURG (102150) 53°11'N 8°10'E Elev. 12m 40 Km NE of Track Center									
0844	E6☉ 20☉	1.6	F-		19.0	16.0	28	1.0	5/8 Fs 6/8 Sc
0944	8☉ E12☉	2.5	H		18.0	14.0	27	2.5	3/8 Fs 7/8 St
1044	25☉ 30☉	4.5	H		20.0	14.0	29	1.5	1/8 Cu 3/8 Sc
1144	30☉ E250☉	5.0	H		21.0	13.0	27	2.5	2/8 Cu 6/8 Ci
AHLHORN (102180) 52°53'N 8°14'E Elev. 49m 26 Km E of Track Center									
0844	18☉ 50☉	3.5	H		20.0	16.0	23	1.5	3/8 Cu 4/8 Sc
0944	12☉ E20☉	3.0	H		20.0	15.0	19	3.0	2/8 Cu 5/8 Cu
1044	10☉ 20☉	3.5	H		20.0	14.0	27	2.0	2/8 Cu 3/8 Sc
1144	18☉ 30☉	3.5	H		21.0	15.0	32	4.6	1/8 Cu 3/8 Sc
MEPPEN (103040) 52°42'N 7°19'E Elev. 19m 39 Km SW of Track Center									
0844	12☉ E40☉	1.8	F-		17.0	15.0	26	2.5	4/8 Sc 6/8 Sc
0944	12☉ E45☉	2.9	H		18.0	14.0	09	1.1	3/8 Sc 6/8 Sc
1044	20☉ 50☉ E250☉	4.8	H		21.0	14.0	29	2.0	2/8 Cu 3/8 Sc 5/8 Ci
LINGEN (103050) 52°31'N 7°19'E Elev. 21m 54 Km SW of Track Center									
0900	E10☉	3.0	F-		18.0	15.0	28	3.6	8/8 St
1000	E10☉	3.0	F-		17.0	15.0	30	3.0	7/8 St
1100	17☉ 250☉	4.0	H		19.0	15.0	26	3.0	3/8 Cu 4/8 Ci
1200	20☉	12.0			21.0	16.0	27	2.6	3/8 Cu

Flight No. C-419 Field Site: Meppen  
 Date: 4 August 1977 Lat. 53°0'N Long. 7°37'E El. 18m

EELDE (062800) 53°8'N 6°35'E Elev. 5m 71 Km WNW of Track Center									
1400	25☉ 250☉	12.0	H		22.0	12.0	29	2.1	2/8 Cu 3/8 Ci
1500	35☉ 250☉	12.0	H		23.0	12.0	09	1.0	1/8 Cu 2/8 Ci
1600	35☉	12.0	H		23.0	11.0	09	1.5	1/8 Cu
1700	250☉	12.0	H		21.0	13.0	04	3.6	1/8 Ci
TWENTHE (062900) 52°16'N 6°54'E Elev. 35m 95 Km SW of Track Center									
1400	35☉ 250☉	8.0	H		23.0	12.0	19	2.6	
1500	35☉ 250☉	8.0	H		22.0	14.0	32	2.1	4/8 Cu 4/8 Ci
1600	40☉ 120☉ 220☉	8.0	H		22.0	13.0	01	1.5	2/8 Cu 3/8 Ac 5/8 Ci
1700	40☉	8.0	H		23.0	13.0	00	0.0	2/8 Cu
OLDENBURG (102150) 53°11'N 8°10'E Elev. 12m 42 Km ENE of Track Center									
1344	35☉ 250☉	6.0	H		23.0	13.0	30	2.5	2/8 Cu 4/8 Ci
1444	35☉ 250☉	6.0	H		21.0	15.0	36	4.1	1/8 Cu 3/8 Ci
1544	35☉ 250☉	7.0	H		21.0	14.0	01	4.1	1/8 Cu 3/8 Ci
1644	35☉ 250☉	7.0	H		20.0	14.0	03	3.1	1/8 Cu 3/8 Ci
AHLHORN (102180) 52°53'N 8°14'E Elev. 12m 43 Km ESE of Track Center									
1344	25☉ 35☉	6.0	H		23.0	12.0	28	3.6	1/8 Cu 3/8 Cu
1444	25☉ 35☉	6.0	H		23.0	12.0	29	3.6	1/8 Cu 3/8 Cu
1544	35☉	11.2			24.0	10.0	30	3.6	2/8 Cu
1644	40☉	11.2			23.0	10.0	31	2.5	1/8 Cu

**Table 6.3. (Cont.) Standard Meteorological Data Sheet**

Flight No. C-419 (cont) Field Site: Meppen  
 Date: 4 August 1977 Lat. 53°0'N Long. 7°37'E El. 18m

Time GMT	Sky and Ceiling (Hundreds of Feet)	Visibility (Kilometers)	Weather and Obstructions To Vision		Temp. (°C)	Dewpoint (°C)	Wind		Remarks
							Direction (00-36)	Speed (mps)	
MEPPEN (103040) 52°42'N 7°19'E Elev. 19m 39 Km SW of Track Center									
1344	40☉	11.2			23.0	12.0	31	3.0	4/8 Cu
LINGEN (103050) 52°31'N 7°19'E Elev. 21m 57 Km SW of Track Center									
1400	22☉	18.0			23.0	14.0	24	3.0	3/8 Cu
1500	23☉	20.0			23.0	13.0	34	3.1	2/8 Cu
1600	23☉	25.0			23.0	12.0	26	2.5	3/8 Cu
1700	24☉	20.0			22.0	13.0	30	2.0	3/8 Cu

Flight No. C-420 Field Site: Meppen  
 Date: 5 August 1977 Lat. 53°0'N Long. 7°37'E El. 18m

Time GMT	Sky and Ceiling (Hundreds of Feet)	Visibility (Kilometers)	Weather and Obstructions To Vision		Temp. (°C)	Dewpoint (°C)	Wind		Remarks
							Direction (00-36)	Speed (mps)	
AHLHORN (102180) 52°53'N 8°14'E Elev. 49m 43 Km ESE of Track Center									
0744	130☉ E250☉	7.0	H		20.0	11.0	24	4.6	2/8 Ac 5/8 Ci
0808	130☉ E250☉	8.0			-	-	24	5.6	2/8 Ac 5/8 Ci
0844	130☉ E250☉	11.2			21.0	8.0	25	5.6	2/8 Ac 5/8 Ci
0944	130☉ E250☉	11.2			22.0	8.0	25	6.6	1/8 Ac 6/8 Ci
1044	130☉ E250☉	11.2			23.0	9.0	25	6.6	1/8 Ac 6/8 Ci
1144	130☉ E250☉	11.2			23.0	11.0	24	6.1	1/8 Ac 7/8 Ci
LINGEN (103050) 52°31'N 7°19'E Elev. 21m 57 Km SW of Track Center									
0800	250☉	20.0			19.0	12.0	22	5.1	4/8 Ci
0900	E250☉	25.0			20.0	11.0	24	5.1	5/8 Ci
1000	130☉ E250☉	25.0			21.0	11.0	23	6.1	1/8 Ac 5/8 Ci
1100	E250☉	30.0			22.0	11.0	24	5.6	5/8 Ci
1200	30☉ 250☉	30.0			23.0	9.0	23	9.0	1/8 Cu 4/8 Ci
1300	35☉ 130☉	35.0			24.0	8.0	24	6.1	1/8 Cu 3/8 Ac
MEPPEN (103040) 52°42'N 7°19'E Elev. 19m 39 Km SW of Track Center									
0744	100☉ 250☉	11.2			17.0	10.0	22	5.1	1/8 Ac 3/8 Ci
0844	100☉ 250☉	11.2			18.0	11.0	23	3.6	1/8 Ac 4/8 Ci
0944	E250☉	11.2			20.0	12.0	23	4.1	5/8 Ci
1044	E250☉	11.2			21.0	12.0	22	5.1	5/8 Ci
EELDE (062800) 53°8'N 6°35'E Elev. 5m 71 Km WNW of Track Center									
0800	60☉ E250☉	18.0			17.0	14.0	20	5.1	1/8 Sc 5/8 Ci
0900	60☉ E250☉	15.0			19.0	15.0	22	5.7	1/8 Sc 6/8 Ci
1000	60☉ E250☉	20.0			20.0	14.0	21	6.2	1/8 Sc 5/8 Ci
1100	60☉ 250☉	25.0			22.0	16.0	21	6.7	1/8 Sc 4/8 Ci
1200	60☉ E250☉	30.0			22.0	14.0	23	8.2	1/8 Sc 5/8 Ci
1300	60☉ E250☉	30.0			22.0	13.0	25	8.8	3/8 Sc 6/8 Ci
TWENTHE (062900) 52°16'N 6°54'E Elev. 35m 95 Km SW of Track Center									
0800	250☉	15.0			17.0	11.0	22	4.6	1/8 Ci
0900	120☉ 250☉	20.0			19.0	17.0	21	5.1	1/8 Ac 3/8 Ci
1000	120☉ 250☉	25.0			20.0	10.0	23	5.1	1/8 Ac 4/8 Ci
1100	120☉ 250☉	25.0			21.0	10.0	23	5.1	1/8 Ac 4/8 Ci
1200	120☉ 250☉	30.0			23.0	7.0	24	5.1	2/8 Ac 3/8 Ci
1300	120☉ 250☉	30.0			23.0	8.0	21	5.1	3/8 Ac 4/8 Ci
OLDENBURG (102150) 53°11'N 8°10'E Elev. 12m 42 Km ENE of Track Center									
0800	100☉ 250☉	11.2			19.0	10.0	22	5.1	1/8 Ac 3/8 Ci
0844	90☉ 250☉	11.2			21.0	8.0	22	6.1	1/8 Ac 4/8 Ci
0944	40☉ 90☉ E250☉	11.2			23.0	9.0	22	6.1	1/8 Cu 3/8 Ac 6/8 Ci
1044	40☉ 90☉ E250☉	11.2			23.0	11.0	25	5.1	1/8 Cu 3/8 Ac 6/8 Ci
1144	40☉ 90☉ E250☉	11.2			24.0	11.0	26	5.1	1/8 Cu 3/8 Ac 7/8 Ci

Flight No. C-421 Field Site: Rodby  
 Date: 10 August 1977 Lat. 54°41'N Long. 11°8'E El. 0m

Time GMT	Sky and Ceiling (Hundreds of Feet)	Visibility (Kilometers)	Weather and Obstructions To Vision		Temp. (°C)	Dewpoint (°C)	Wind		Remarks
							Direction (00-36)	Speed (mps)	
FEHMARNBELT (100060) 54°36'N 11°9'E Elev. 4m 9 Km South of Track Center									
0900	150	10.0			17.0	14.0	27	5.1	3/8 Sc
1200	E15☉	10.0			20.0	16.0	25	1.5	5/8 Cu & Sc
1500	E15☉	20.0			19.0	14.0	09	2.1	6/8 Cu & Sc
SCHLESWIG (100350) 54°32'N 9°33'E Elev. 48m 103 Km W of Track Center									
0900	E15☉ 35☉	8.0			16.0	14.0	20	3.1	5/8 Cu 7/8 Sc
1000	E15☉ 35☉	8.0			17.0	14.0	21	4.6	5/8 Cu 7/8 Sc
1100	20☉ E40☉	10.0			17.0	14.0	24	2.5	3/8 Cu 6/8 Sc
1200	25☉ E40☉	12.0			17.0	12.0	24	0.5	3/8 Cu 6/8 Sc
1300	21☉ E50☉	10.0	RW-		17.0	14.0	19	2.0	2/8 Cb 7/8 Sc
1400	20☉ 21☉ E40☉	10.0			17.0	14.0	26	0.5	1/8 Cb 3/8 Cu 7/8 Sc RW Distant

**Table 6.3. (Cont.) Standard Meteorological Data Sheet**

Flight No. C-422		Field Site: Rodby					
Date: 11 August 1977		Lat. 54°41'N Long. 11°8'E El. 0m					
Time GMT	Sky and Ceiling (Hundreds of Feet)	Visibility (Kilometers)	Weather and		Wind		Remarks
			Obstructions To Vision	Temp. (°C)	Dewpoint (°C)	Direction (00-36)	
FEHMARNBELT (100060) 54°36'N 11°9'E Elev. 4m 9 Km South of Track Center							
0900	E10☉	4.0	F-	18.0	16.0	04	4.1 8/8 Sc
1200	E10☉	10.0		18.0	16.0	04	4.6 8/8 Sc
SCHLESWIG (100350) 54°32'N 9°33'E Elev. 48m 103 Km W of Track Center							
0900	10☉	4.0	F-	19.0	15.0	08	2.1 4/8 Cu
1000	20☉ 30☉	6.0	H	19.0	14.0	09	3.0 3/8 Cu 4/8 Sc
1100	25☉ 120☉	8.0	H	21.0	13.0	10	2.5 3/8 Cu 4/8 As
1200	25☉ 30☉	10.0		21.0	13.0	07	4.6 2/8 Cu 3/8 Sc

**Table 6.4. Satellite Cloud Cover Comparisons**

Flight	Date	Flight Times GMT	Map Time GMT	Track Flown	OPAQUE III Flight Track Conditions			
					Bruz	Rodby	Meppen	Soesterberg
C-410	4 Jul	1119-1432	1149	Bruz	<u>Not Shown</u>	Clear	Clear	Clear
C-411	6 Jul	0902-1113	1149	Bruz	<u>Clear</u>	Cloudy	Clear	Clear
C-412	7 Jul	0845-1233	0755& 1149	Bruz	<u>Clouds South</u>	Cloudy	Cloudy	Cloudy
C-413	27 Jul	1441-1603	1309	Rodby	Cloudy	<u>Cloudy</u>	Cloudy	Cloudy
C-414	28 Jul	0932-1136	-	Ahlhorn				
C-415	29 Jul	1027-1207	1309	Meppen	Thin Clouds	Thick Clouds	<u>Thick Clouds</u>	Thick Clouds
C-416	1 Aug	1124-1450	1310	Rodby	Clouds	<u>TC or Clear</u>	Thick Clouds	Thick Clouds
C-418	4 Aug	0847-1008	1309	Ahlhorn	Clear	Clear	<u>Thin Clouds</u>	Thin Clouds
C-419	4 Aug	1436-1608	1309	Meppen	Clear	Clear	<u>Thin Clouds</u>	Thin Clouds
C-420	5 Aug	0840-1119	1309	Meppen	Thick Clouds	Thin Clouds	<u>Thin Clouds</u>	<u>Thin Clouds</u>
C-421	10 Aug	1012-1412	1309	Rodby	Clear	Clouds	<u>Clouds</u>	Clouds
C-422	11 Aug	0953-1120	1311	Rodby	Clear	<u>Cloudy</u>	Cloudy	Cloudy

\*The underlines indicate the tracks which were flown.

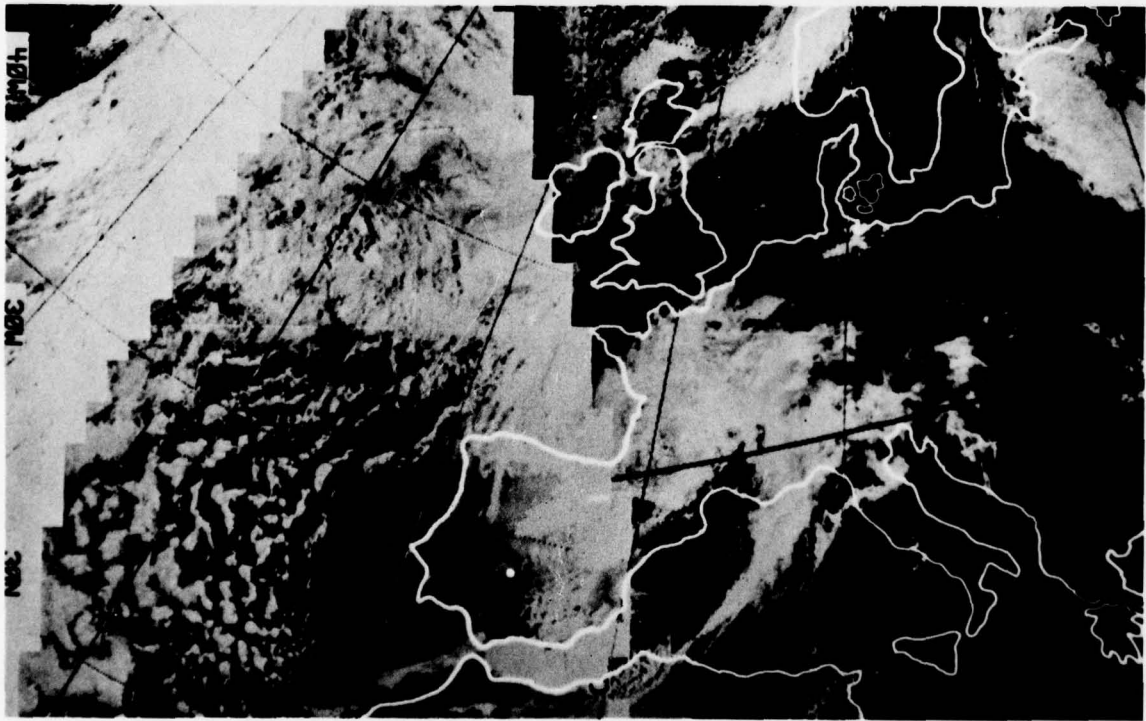
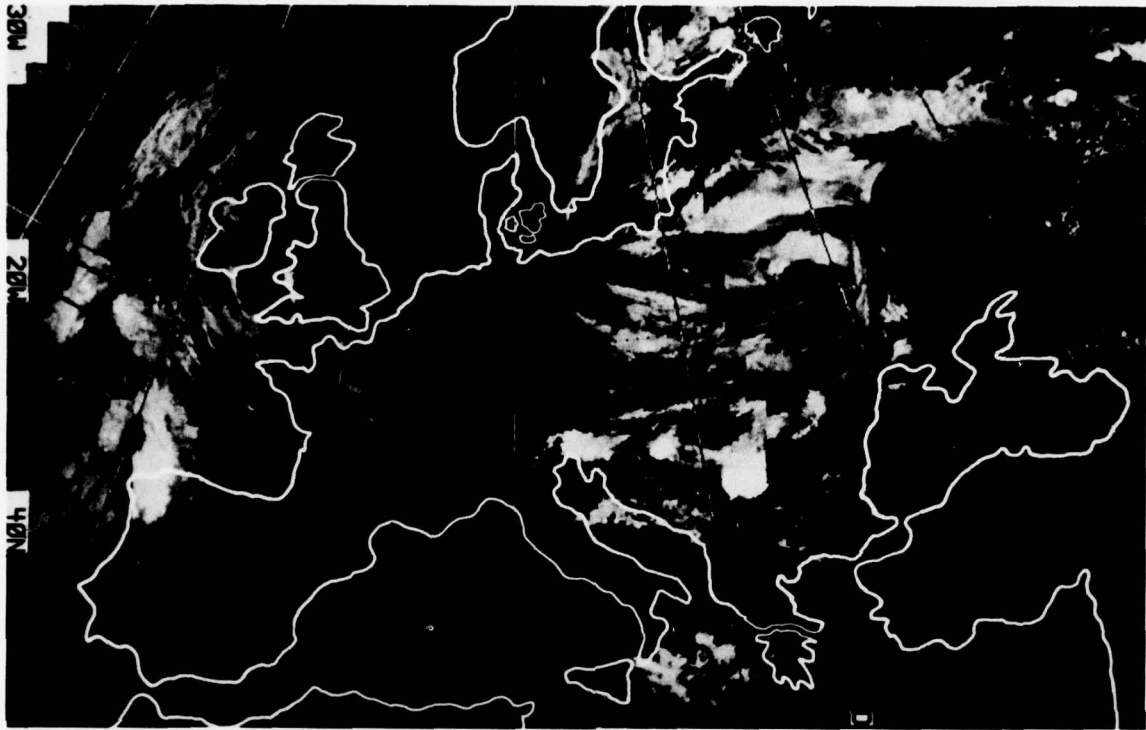

Fig. 6-4a. Satellite Photographs for 5 July 77, 1154 GMT, Reference Flts. C-410-411 (Upper) and for 30 July 77, 1309 GMT, Reference Flts. C-415 and C-416 (Lower)

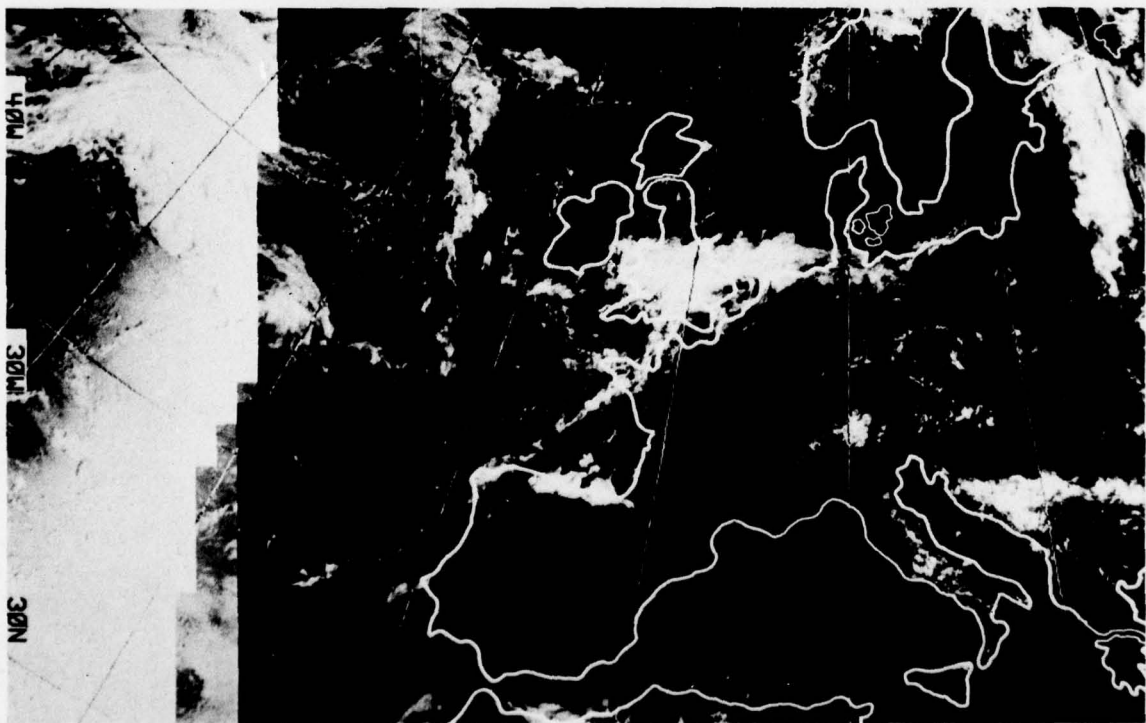
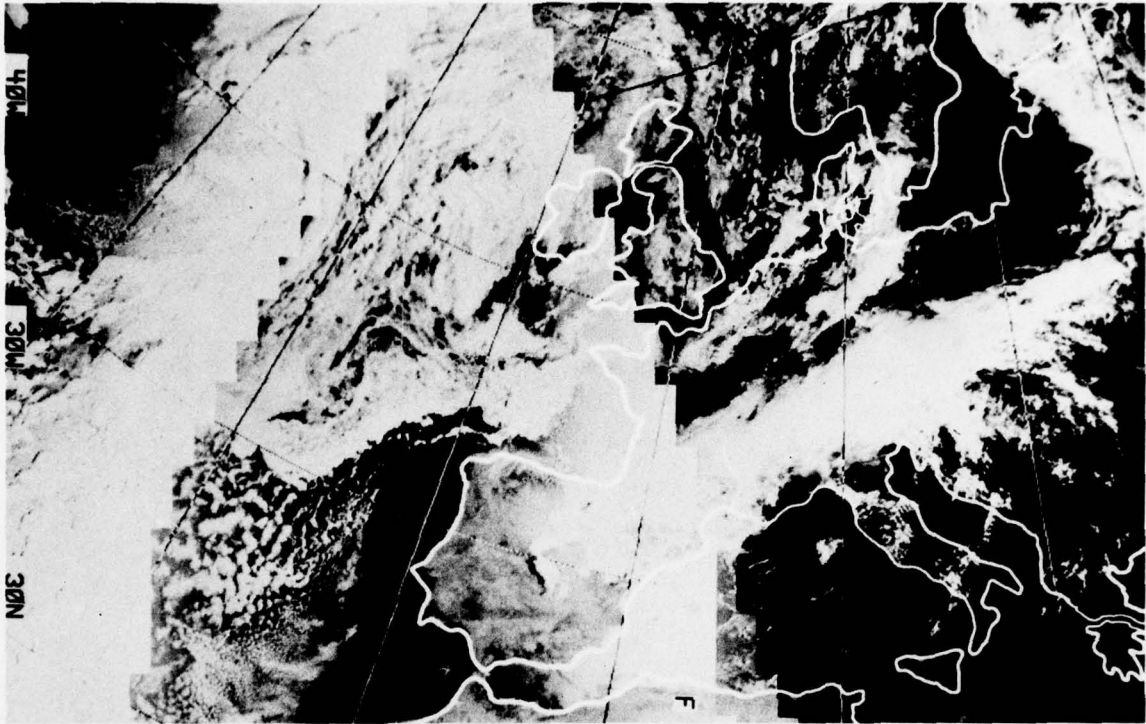

Fig. 6-4b. Satellite Photographs for 31 July 77, 1310 GMT, Reference Flts. C-415 and C-416 (Upper) and for 6 August 77, 1310 GMT, Reference Flts. C-419 and C-420 (Lower).

## 7. DATA PRESENTATION

### 7.1. AIRBORNE DATA AND FLIGHT SUMMARY

Between 4 July and 11 August 1977, thirteen flights were made in northern Europe. Twelve of these flights contain useable data profiles. Selected data for these flights are reported herein.

The 12 flights were conducted in northern Europe on four flight tracks in Denmark, France, and Germany (see Fig. 1-1). The latitude, longitude, and altitude of each flight track are given in Table 7.1. The terrain beneath three of the flight tracks, those in Germany and France, was low lying and flat, mostly cultivated farmlands. The flight track in Denmark was mostly over water.

The ground station operated from 7 July to 3 August 1977 near the flight tracks in Germany and France, but was not utilized during the flights in Denmark. Its location and dates of operation are also noted in Table 7.1.

### PHOTOGRAPHIC DOCUMENTATION

Sky and terrain conditions encountered during the data flights were documented photographically during each straight and level flight sequence, at each of several designated altitudes, in conjunction with the radiometric measurements made in each spectral filter. On sunlit days the documentary photographs were taken simultaneously with the measurements made by the upper hemisphere scanner in the sun mode. On overcast days the photographs were taken simultaneously with the measurements of sky and terrain radiance. One should be aware that while the photographs are instantaneous, the data measurements require a four-minute interval for completion. In four minutes the aircraft travels approximately ten miles.

The photographs illustrating upper and lower hemisphere conditions during each of the 12 flights have been examined and classified with respect to discernible cloud conditions. A summary of these general cloud and terrain descriptions, augmented by the descriptions given by the on-board meteorologist, is presented in Table 7.2.

The upper hemisphere cloud conditions for each flight appear to fall into four very general categories: (1) mostly clear to scattered clouds; (2) mostly scattered to broken clouds; (3) mostly broken clouds to overcast; (4) mostly overcast.

**Table 7.1. Location and Ground Elevation of Flight Tracks and Ground Sites**

Field Site	Latitude	Longitude	Approximate Ground Elevation (meters)	Dates of Operation (1977)	Flight No.
<b>FLIGHT TRACK</b>					
Bruz, France	48°01'N	1°41'W	46	Jul 4,6,7	410,411,412
Ahlhorn, Germany	52°53'N	7°51'E	18	Jul 28, Aug 4	414,418
Meppen, Germany	53°00'N	7°38'E	18	Jul 29 Aug 4,5	415,419,420
Rodby, Denmark	54°41'N	11°08'E	0	Jul 27 Aug 1,10,11	413,416,421,422
<b>GROUND STATION</b>					
Bruz, France (CELAR)	48°01'N	1°45'W		Jul 7,8	
Meppen, Germany (Erprobungsstelle 91)	52°52'N	7°23'E		Jul 26,27,28,29 Aug 1,2,3	

**Table 7.2. Summary of Hemispherical Pictures and In-Flight Meteorologists Descriptions**

UPPER HEMISPHERE  
 ○ Clear ◐ Scattered ⊕ Broken ⊕ Overcast - Thin V varying

Flight No.	Filter No.	~300m (215-425m)	~1500m (712-1679m)	~3000m (2834-3394m)	~5700m (4563-5857m)
C-410	2,3	⊕V⊕	⊕	⊕V⊕	
	4,5	⊕	⊕V⊕	⊕V⊕	
C-411	2,3	○	○V-⊕	○V-⊕	
	4,5	⊕V	⊕V	⊕V⊕	
C-412	2,3	○	○	○V⊕	○V⊕
	4,5	○V-⊕	○	○	○V⊕
C-413	3	⊕*	⊕*	⊕*	⊕*
	4	⊕*	⊕*	-⊕*	-⊕*
	5	⊕*	⊕V⊕*	⊕*	⊕V⊕*
C-414	2	⊕*	⊕*	⊕*	-⊕*
	3	⊕*	⊕V⊕	⊕*	
	4	⊕*	⊕V⊕	⊕*	
	5	⊕*	⊕V⊕	⊕*	
	4,5	⊕	⊕		
C-415	2,3	⊕	⊕		
	4,5	⊕	⊕		
C-416	2,3	⊕	-⊕	-⊕V⊕	-⊕V⊕
	4,5	-⊕V-⊕	-⊕V-⊕	-⊕V-⊕	-⊕
C-418	2	⊕*	-⊕*	-⊕*	-⊕*
	4	⊕*	-⊕*	-⊕*	-⊕*
	3	⊕*	⊕V-⊕*	-⊕*	-⊕*
	5	⊕*	-⊕*	-⊕*	-⊕*
	2,3	⊕V⊕	⊕V⊕		
C-419	4,5	⊕	⊕V⊕		
	2,3	-⊕V-⊕	⊕V⊕	-⊕V-⊕	
C-420	4,5	-⊕	-⊕	-⊕	
	2,3	-⊕	-⊕	-⊕	-⊕
C-421	4,5	-⊕V-⊕	-⊕V-⊕	-⊕V-⊕	-⊕
	2,3	⊕	⊕		
C-422	4,5	⊕	⊕		
	2,3	⊕	⊕		

\*From V-Pro pictures only.

Photographs illustrating typical sky and terrain conditions during four of the flights reported herein are shown in Figs. 7-1 and 7-2. In each instance, the picture on the left represents the sky (upper hemisphere) as seen through a 180-degree lens, and the picture on the right represents the terrain (lower hemisphere). The photographs were selected to represent the conditions encountered at both the highest and lowest flight altitudes during each of the four flights.

The pictures representing Flight C-412 (Fig. 7-1) illustrate the mostly clear to scattered clouds, the conditions of category one, and the Bruz flight track in France. The underlying terrain was mostly cultivated farmlands.

Table 7.2 (cont.). Summary of Hemispherical Pictures and In-Flight Meteorologists Descriptions

LOWER HEMISPHERE									
Flight No. and Track	Filter No.	~300m (215-425m)		~1500m (712-1679m)		~3000m (2834-3394m)		~5700m (4563-5857m)	
		Clouds	Haze	Clouds	Haze	Clouds	Haze	Clouds	Haze
C-410 Bruz Green/brown fields	2,3	○	Moderate	⊙	Moderate	⊙	Moderate		
	4,5	○	Moderate	○	Moderate	⊙VO	Moderate		
C-411 Bruz Green/brown fields	2,3	○	Heavy	○	Heavy	○	Heavy		
	4,5	○	Heavy	⊙	Heavy	⊙	Heavy		
C-412 Bruz Green/brown fields	2,3	○	Heavy	⊙	Heavy	○	Heavy	⊙	Heavy
	4,5	○	Heavy	⊙VO	Heavy	⊙VO	Heavy	⊙	Heavy
C-413 Rodby Ocean near Coast	3	○	Light*	○	Light*	○	Light*	⊙*	Light*
	4	○	Light*	○	Light*	○	Light*	⊙*	Light*
	5	○	Light*	○	Light*	⊙	Light*	○	Light*
	2	○	Light*	○	Light*	○	Light*	⊙	Light*
C-414 Ahihorn Green/gold fields	2			⊙	Moderate*	⊙	Heavy*		
	3	○	Light*	○	Moderate*	⊙	Heavy*		
	4			⊙	Heavy*	⊙	Heavy*		
	5			○		⊙	Heavy*		
C-415 Meppen Green/gold fields	4,5	○	Moderate	⊙VO	Moderate				
	2,3	○	Moderate	⊙	Moderate				
C-416 Rodby Ocean near coast	2,3	○	Light-mod.	○	Light-mod.	⊙	Light-mod.	⊙	Light-mod.
	4,5	⊙	Light-mod.	○	Light	⊙	Light	○	Light
C-418 Ahihorn Green/gold fields	2			⊙	Heavy*	⊙	Heavy*	⊙	Heavy*
	4			⊙	Heavy*	⊙	Heavy*	⊙	Heavy*
	3	○	Moderate*	⊙	Heavy*	⊙	Heavy*	⊙	Heavy*
	5			⊙	Heavy*	⊙	Heavy*	⊙	Heavy*
C-419 Meppen Green/gold fields	2,3	○	Moderate	○	Moderate				
	4,5	○	Moderate	○	Moderate				
C-420 Meppen Green/gold fields	2,3	○	Light	○	Light-mod.	○	Light		
	4,5	○	Light-mod.	○	Moderate	○	Light-mod.		
C-421 Rodby Ocean near coast	2,3	○	Light-mod.	○	Light-mod.	⊙	Light-mod.	⊙	Light-mod.
	4,5	○	Light-mod.	⊙	Light-mod.	⊙	Light-mod.	⊙VO	Light-mod.
C-422 Rodby Ocean near coast	2,3	⊙VO	Heavy	○	Heavy				
	4,5	○	Heavy	○	Heavy				

\*From V-Pro pictures only.

The pictures representing Flight C-416 (Fig. 7-2) illustrate the cloud conditions of category two. Flight C-416 was over the Rodby track in Denmark which was mostly over water in the Femer Bay.

Flight C-410 (Fig. 7-1) illustrates category three. It was also over the Bruz track in France.

The pictures representing Flight C-415 (Fig. 7-2) illustrate the mostly overcast conditions of category four. Flight C-415 was over the Meppen track in Germany. The underlying terrain was again mostly cultivated farmlands.

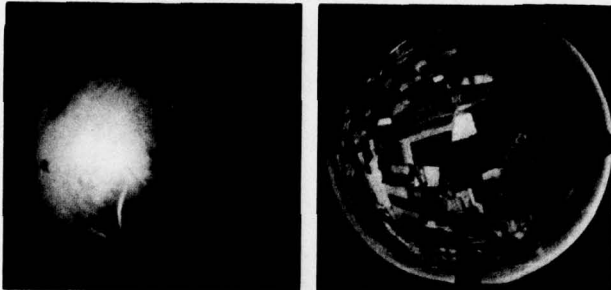

**FLIGHT C-410  
Bruz Track**

Upper and Lower Hemisphere  
408 m AGL 1255 GMT

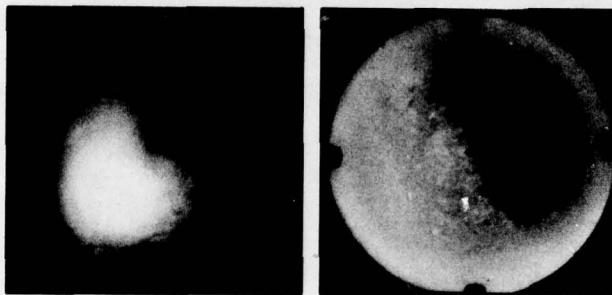

Upper and Lower Hemisphere  
3170 m AGL 1407 GMT

Fig. 7-1. Typical Sky and Terrain Photographs for Flights C-410 and C-412.



**FLIGHT C-412  
Bruz Track**

Upper and Lower Hemisphere  
283 m AGL 1042 GMT

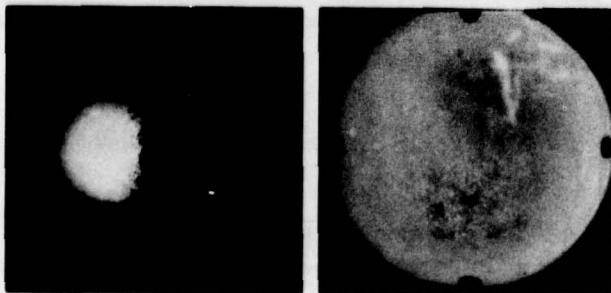

Upper and Lower Hemisphere  
5640 m AGL 1202 GMT

**FLIGHT C-415  
Meppen Track**

Upper and Lower Hemisphere  
215 m AGL 1027 GMT

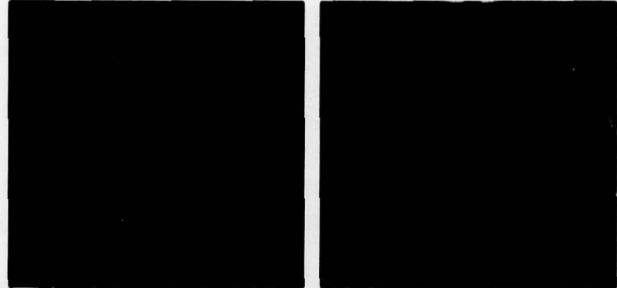

Upper and Lower Hemisphere  
858 m AGL 1054 GMT



Fig. 7-2. Typical Sky and Terrain Photographs for Flights C-415 and C-416.

**FLIGHT C-416  
Rodby Track**

Upper and Lower Hemisphere  
279 m AGL 1319 GMT



Upper and Lower Hemisphere  
3058 m AGL 1412 GMT



## RADIOMETRIC DOCUMENTATION

Table 7.3 contains a summary of pertinent descriptive information on the 12 flights for which radiometric data are reported herein. The flight numbers are sequential. The times under the total time of data-taking column are Greenwich Mean Time (GMT) and Local Civil Time (LCT). The LCT is equal to GMT+1. The sun zenith angles are tabulated for the time when data-taking began, at the time of sun transit (minimum sun zenith angle), and at the conclusion of the last data-taking. The maximum and minimum flight altitudes are noted in columns 12 and 13.

The total volume scattering coefficient, equivalent attenuation length and beam transmittance data are presented both tabularly and graphically in Section 7.3. The downwelling irradiance data are presented graphically only. All of the data are grouped into sets by flight number. A detailed description and report of the existing weather conditions are given as the introductory page to each data set.

Users should be alert to the fact that the data collected on ascents are taken in two or three segments separated in time by the straight and level flight elements. Thus the consecutive segments of these V-PROS may be separated by as much as 10 to 15 minutes in time. For more specific discussion of these and other profile characteristics, the user is referred to Section 8.2.

Table 7.3. Flight Data Summary, Including ST&LV and V-PRO Flight Elements

Flight No.	Date (1977)	Total Time of Data Taking				Filter	Sun Zenith Angle (degrees)			Flight Altitude meters (AGL)	
		Start		End			Start	Transit	End	Min	Max
		GMT	LCT	GMT	LCT						
C-410	4 Jul	1119	1219	1249	1349	2,3	27.2	25.2	26.3	150	3180
		1255	1355	1432	1532	4,5	26.6	-	37.8	120	3180
C-411	6 Jul	0902	1002	0959	1059	2,3	45.1	-	36.4	150	2875
		1003	1103	1113	1213	4,5	35.9	-	27.8	120	2850
C-412	7 Jul	0845	0945	1036	1136	2,3	48.0	-	31.7	180	5640
		1043	1143	1233	1333	4,5	31.0	25.4	25.8	150	5640
C-413	27 Jul	1441	1541	1455	1555	3	51.7	-	53.7	120	5670
		1458	1558	1517	1617	4	54.0	-	56.8	120	5580
		1525	1625	1540	1640	5	57.7	-	59.9	120	5700
		1543	1643	1603	1703	2	60.2	-	63.3	120	5340
C-414	28 Jul	0939	1039	1110	1210	2	40.7	-	34.3	120	3000
		0940	1040	1059	1159	3	40.5	-	34.6	60	3030
		0942	1042	1032	1132	4	40.4	-	36.0	930	3000
		0943	1043	1136	1236	5	40.2	-	33.9	30	3030
C-415	29 Jul	1027	1127	1123	1223	4,5	36.8	-	34.4	90	870
		1126	1226	1207	1307	2,3	34.4	34.3	34.9	60	870
C-416	1 Aug	1124	1224	1312	1412	2,3	36.7	36.7	42.4	120	4590
		1319	1419	1450	1550	4,5	43.0	-	53.9	180	4620
C-418	4 Aug	0847	0947	0905	1005	2	48.3	-	45.9	150	4530
		0910	1010	0930	1030	4	45.4	-	43.1	90	4590
		0930	1030	0949	1049	3	43.1	-	41.1	210	4620
		0953	1053	1008	1108	5	40.8	-	39.4	240	4560
C-419	4 AUG	1436	1536	1518	1618	2,3	50.1	-	56.0	120	750
		1524	1624	1608	1708	4,5	56.8	-	63.4	120	750
C-420	5 AUG	0840	0940	0957	1057	2,3	49.6	-	40.7	90	3060
		1002	1102	1119	1219	4,5	40.4	-	36.2	60	3060
C-421	10 Aug	1012	1112	1210	1310	2,3	41.4	39.2	40.4	120	5850
		1218	1318	1412	1512	4,5	40.7	-	51.3	120	5850
C-422	11 Aug	0953	1053	1040	1140	2,3	42.9	-	40.2	120	1560
		1044	1144	1120	1220	4,5	40.1	39.5	39.5	120	1560

## 7.2. DESCRIPTION OF AIRBORNE DATA TABLES AND GRAPHS

### DATA TABLES

Data are presented in tables of:

- Total Volume Scattering Coefficient
- Equivalent Attenuation Length
- Beam Transmittance Between Ground and Altitude

Each optical property is tabulated in the tables as a function of altitude above ground level. The data are further divided by optical filters which are given in order of increasing wavelength.

The tables have been divided into two categories depending upon the meaning of the altitude in the tables, (1) the variable tabulated by measurement altitude: total volume scattering coefficient, and (2) the variables tabulated by object or sensor altitude depending on whether the path of sight is upward or downward: equivalent attenuation length, and beam transmittance.

#### CATEGORY I: MEASUREMENT ALTITUDE

*Total Volume Scattering Coefficient.* The total volume scattering coefficient  $s(z)$  is tabulated by measurement altitude in two to four columns for the optical filters. The altitude is given in meters, above ground level, at 30 meter (98.4-foot) increments. The measurement unit for the total scattering coefficient is  $m^{-1}$ . The extrapolated points above or below the actual altitudes of measurement are indicated by parentheses.

The first and last data altitudes are given at the bottom of the total scattering coefficient table. These are the lowest and highest altitudes of airborne data measurements.

The total scattering coefficient is used for the calculation of atmospheric beam transmittance and equivalent attenuation length in the ensuing tables using the equations of the Theory, Section 2.

#### CATEGORY II: OBJECT OR SENSOR ALTITUDE

These variables are tabulated by object or sensor altitude depending upon whether the path of sight is upward or downward. For upward paths of sight  $\theta < 90^\circ$  the sensor is at ground level and the altitudes shown in the table are the object altitudes. For the downward paths of sight  $\theta > 90^\circ$ , the object is at ground level and the altitudes in the table are the sensor altitudes.

*Equivalent Attenuation Length.* The equivalent attenuation length  $\bar{L}(z)$  is a pseudo-attenuation length which, when combined with its altitude  $z$ , can be used directly in Eq. 2.6 to compute beam transmittance. The equivalent attenuation length permits easy calculation of the atmospheric beam transmittance between ground level and altitude  $z$  above ground level for any downward path of sight from 95 degrees to 180 degrees in zenith angle or between altitude and ground level for any upward path of sight from 0 degrees to 85 degrees in zenith angle.

The equivalent attenuation length  $\bar{L}(z)$  is tabulated by altitude for the path of sight between ground and the altitude shown in two to four columns for the optical filters. The altitude is given in meters, above ground level, at 300-meter (984-foot) increments. The unit for the equivalent attenuation length is "m."

*Beam Transmittance Between Ground and Altitude.* The atmospheric beam transmittance is tabulated for the vertically upward path of sight  $T_z(0,0^\circ)$  or the vertically downward path of sight  $T_z(z,180^\circ)$  for the path of sight between ground and the altitude shown. The beam transmittance is computed from measurements of total scattering coefficient. The assumption is made that there is no significant atmospheric absorption in the pass bands of the measurements, whence the atmospheric attenuation coefficient  $\alpha(z)$  is assumed equivalent to the scattering coefficient  $s(z)$ .

The vertical beam transmittance is tabulated by altitude for the path of sight between ground and the altitude shown in two to four columns for the optical filters. The altitude is given in meters, above ground level, at 300-meter (984-foot) increments. This property is dimensionless.

## DATA GRAPHS

Data are also presented in graphs of:

- Total Volume Scattering Coefficient
- Equivalent Attenuation Length, Between Ground and Altitude
- Vertical Beam Transmittance, Between Ground and Altitude
- Downwelling Irradiance

*Total Volume Scattering Coefficient.* The total volume scattering coefficient  $s(z)$  in  $m^{-1}$  is graphed using a single average value for each 30-meter altitude interval. Identifying symbols for the spectral filters appear every fifth data point, or at 150-meter intervals. These same data were tabulated in the total scattering coefficient table. The extrapolated values are indicated by a dashed line.

*Equivalent Attenuation Length.* The equivalent attenuation length  $\bar{L}(z)$  in meters, for the path between ground and altitude, is graphed for each 30-meter altitude interval. This represents smaller altitude increments than in the tabular display of equivalent attenuation length. Spectral identifying symbols appear at 150-meter intervals or every fifth data point.

*Vertical Beam Transmittance Between Ground and Altitude.* The vertical beam transmittance  $T_z(0,0^\circ)$  or  $T_z(z,180^\circ)$  between ground and altitude is graphed for each 30-meter altitude interval. This represents smaller altitude increments than in the tabular display of beam transmittance. Spectral identifying symbols appear at 150-meter intervals or every fifth data point.

*Downwelling Irradiance.* The downwelling irradiance  $H(z,d)$  is graphed as a function of altitude above ground level (AGL). These irradiances were measured by the dual irradiator concurrently with the total volume scattering coefficient measurements. The downwelling irradiance during the ascent or descent is graphed using a single average value for each 30-meter altitude interval and the

identifying symbol for the spectral filter appears every fifth data point; thus when data are continuous the symbols appear at 150-meter intervals. The second symbol for each filter designates the average value measured during each three-minute straight and level flight element.

### **7.3. PRESENTATION OF AIRBORNE DATA**

Tabular listings and graphical displays of the data discussed in Section 7.2 are presented in the pages immediately following. Users should be aware that regardless of the display format, the data values are valid to, at best, only three significant figures. The tables of beam transmittance, in particular, should be rounded off to 2 digits prior to further application.

It should also be remembered that all values in the data tables except scattering coefficient are computed values based upon the measured values of scattering coefficient.

All altitudes presented in the data tables, in the flight description, and in the graphs are given as above ground level (AGL) unless otherwise specified.

FLIGHT C-410 - 4 JULY 1977 - DESCRIPTION OF FLIGHT & WEATHER CHARACTERISTICS

Filter Ident	Data Interval			Solar Zenith Angle			Maximum Flight Altitude (m)	Average Terrain Elevation (m)
	Start (GMT)	End (GMT)	Elapsed (hrs)	Initial ST&LV (degrees)	Solar Transit (degrees)	Final V-PRO (degrees)		
2 & 3	1119	1249	1.5	27.2	25.2	26.3	3180	46
4 & 5	1255	1432	1.6	26.6		37.8	3180	46

Flight C-410 was a midday flight, spanning local apparent noon. There were multiple cloud layers varying from scattered cumulus to overcast cirrus.

The approximate east-west Bruz track was centered south of Rennes in northwestern France. Typical terrain features were green and brown fields interspersed with small towns.

The in-flight observer reported broken to overcast altostratus clouds at the beginning of the flight with scattered cumulus forming at 1200 meters (4000 feet) after 1153 GMT. Tops of the cumulus were 1500 meters (5000 feet) and built to 1800 meters (6000 feet) before the end of the flight. Moderate haze was reported at all altitudes.

Data from Rennes, 7 kilometers north of the center of the flight track, show 1/8 to 3/8 cumulus at altitudes varying from 900 to 1380 meters (3000 to 4600 feet), 3/8 to 5/8 altostratus at 3000 meters (10,000 feet) and 7/8 cirrus at 6000 meters (20,000 feet). Visibility of 20.0 kilometers decreased to 11.2 kilometers by the end of the flight.

Nantes/Chateau Bougon, 78 kilometers south of the track center point, reported 1/8 cumulus increasing to 4/8 at altitudes varying from 1200 to 1380 meters (4000 to 4600 feet) and 3/8 to 7/8 altocumulus at 3000 meters (10,000 feet). Visibility varied from 25.0 to 11.2 kilometers.

The radiosonde station at Brest was 208 kilometers westnorthwest of the flight track center and located in a prevailing airflow that was parallel with the track.

The surface charts show a 1024 millibar high east of Denmark. Most of France was in a col with pressures about 1014 millibars. At 500 millibars there was a low pressure trough over southern France. The flow was easterly and the air mass was modified unstable maritime polar.

FLIGHT NO. C-410

BRUZ

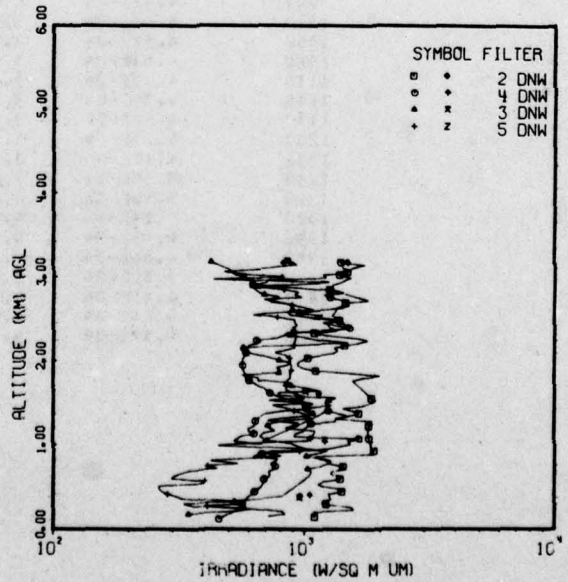
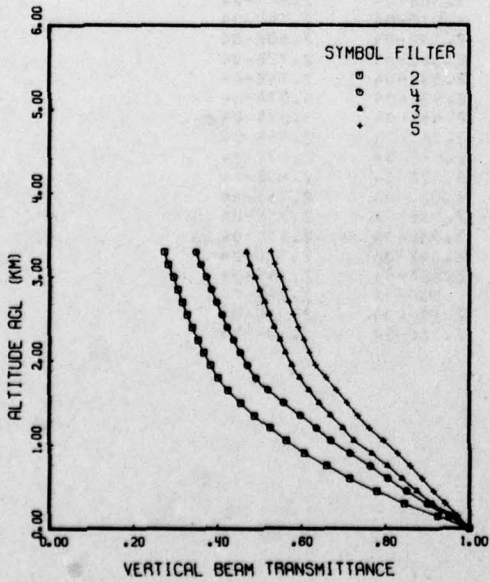
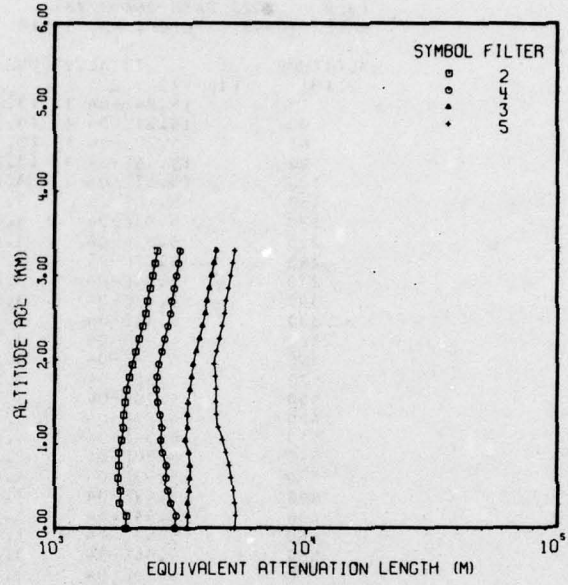
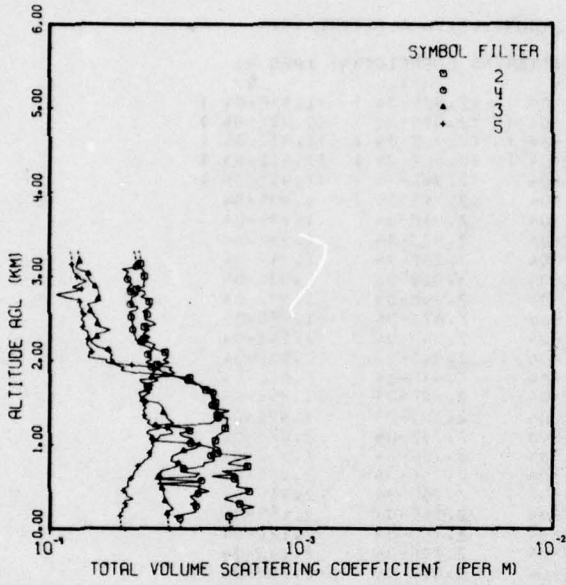

## FLIGHT NO. C-410 TOTAL VOLUME SCATTERING COEFFICIENT

(JOB 2022 DATE 06/09/78)  
DATE 70477 FLIGHT NO. C-410 GROUND LEVEL ALTITUDE (M)= 46

ALTITUDE (M)	TOTAL VOLUME SCATTERING COEFFICIENT (PER M)			
	FILTERS	2	4	3
0	(5.24E-04 )	(3.34E-04 )	(2.98E-04 )	(1.93E-04 )
30	(5.21E-04 )	(3.32E-04 )	(2.97E-04 )	(1.92E-04 )
60	(5.20E-04 )	(3.31E-04 )	(2.96E-04 )	(1.91E-04 )
90	(5.18E-04 )	(3.30E-04 )	(2.95E-04 )	(1.91E-04 )
120	(5.17E-04 )	3.29E-04	(2.94E-04 )	(1.91E-04 )
150	5.16E-04	3.11E-04	(2.94E-04 )	1.90E-04
180	5.83E-04	3.47E-04	2.93E-04	1.90E-04
210	5.97E-04	3.82E-04	2.98E-04	1.95E-04
240	5.77E-04	3.77E-04	3.10E-04	1.94E-04
270	6.51E-04	3.83E-04	3.01E-04	2.03E-04
300	5.67E-04	3.62E-04	2.95E-04	1.99E-04
330	5.31E-04	3.81E-04	2.87E-04	1.98E-04
360	4.91E-04	3.70E-04	2.84E-04	2.14E-04
390	5.24E-04	3.61E-04	2.84E-04	2.02E-04
420	5.68E-04	3.87E-04	2.83E-04	2.01E-04
450	5.20E-04	4.31E-04	2.82E-04	1.96E-04
480	6.27E-04	3.90E-04	2.80E-04	1.99E-04
510	5.54E-04	4.01E-04	2.79E-04	2.07E-04
540	5.70E-04	2.70E-04	2.78E-04	2.05E-04
570	5.63E-04	4.05E-04	2.76E-04	2.06E-04
600	5.47E-04	2.63E-04	2.75E-04	2.11E-04
630	4.44E-04	3.84E-04	2.74E-04	2.15E-04
660	5.53E-04	3.98E-04	2.76E-04	2.17E-04
690	4.86E-04	3.33E-04	2.79E-04	2.19E-04
720	6.23E-04	3.43E-04	3.01E-04	2.24E-04
750	5.15E-04	4.12E-04	3.22E-04	2.25E-04
780	5.14E-04	4.13E-04	3.27E-04	2.35E-04
810	5.37E-04	4.51E-04	3.04E-04	2.39E-04
840	5.87E-04	4.53E-04	3.07E-04	2.47E-04
870	6.37E-04	4.39E-04	3.10E-04	2.55E-04
900	4.66E-04	4.51E-04	3.25E-04	2.49E-04
930	4.75E-04	4.48E-04	3.42E-04	2.55E-04
960	4.75E-04	4.52E-04	3.73E-04	2.55E-04
990	4.48E-04	4.08E-04	3.96E-04	2.60E-04
1020	4.46E-04	3.64E-04	3.97E-04	2.54E-04
1050	4.57E-04	3.74E-04	2.59E-04	2.60E-04
1080	4.61E-04	3.67E-04	2.56E-04	2.72E-04
1110	4.62E-04	3.36E-04	2.53E-04	2.74E-04
1140	4.79E-04	3.29E-04	2.43E-04	3.07E-04
1170	4.98E-04	3.61E-04	2.49E-04	3.07E-04
1200	5.01E-04	3.77E-04	2.76E-04	2.95E-04
1230	5.10E-04	2.92E-04	2.65E-04	2.57E-04
1260	5.10E-04	4.41E-04	3.12E-04	2.45E-04
1290	5.10E-04	4.56E-04	3.02E-04	2.51E-04
1320	5.13E-04	4.69E-04	2.94E-04	2.36E-04
1350	4.65E-04	4.94E-04	2.93E-04	2.40E-04
1380	4.66E-04	4.83E-04	2.84E-04	2.38E-04
1410	4.60E-04	5.19E-04	2.82E-04	2.36E-04
1440	4.67E-04	4.38E-04	2.83E-04	2.43E-04
1470	4.64E-04	4.43E-04	2.78E-04	2.36E-04
1500	4.57E-04	4.48E-04	2.71E-04	2.40E-04

**FLIGHT NO. C-410**  
**TOTAL VOLUME SCATTERING COEFFICIENT**

(JOB 2022 DATE 06/09/78)  
 DATE 70477 FLIGHT NO. C-410 GROUND LEVEL ALTITUDE (M)= 45

ALTITUDE (M)	TOTAL VOLUME SCATTERING COEFFICIENT (PER M)				
	FILTERS	2	4	3	5
1530		4.51E-04	4.46E-04	2.35E-04	2.43E-04
1560		4.56E-04	4.41E-04	2.35E-04	2.30E-04
1590		4.43E-04	4.44E-04	2.41E-04	2.29E-04
1620		4.31E-04	4.47E-04	2.51E-04	2.26E-04
1650		4.18E-04	4.36E-04	2.38E-04	2.47E-04
1680		4.05E-04	4.00E-04	2.48E-04	2.38E-04
1710		3.92E-04	3.95E-04	2.59E-04	2.38E-04
1740		3.80E-04	3.65E-04	2.32E-04	2.54E-04
1770		3.67E-04	3.53E-04	2.28E-04	2.70E-04
1800		3.60E-04	3.30E-04	2.65E-04	2.54E-04
1830		2.91E-04	3.06E-04	2.89E-04	2.55E-04
1860		3.15E-04	2.82E-04	2.18E-04	2.59E-04
1890		2.99E-04	2.74E-04	1.93E-04	2.65E-04
1920		3.05E-04	2.54E-04	1.97E-04	2.60E-04
1950		2.67E-04	2.57E-04	1.83E-04	2.12E-04
1980		2.99E-04	2.41E-04	1.78E-04	1.68E-04
2010		2.82E-04	2.54E-04	1.75E-04	1.69E-04
2040		2.95E-04	2.52E-04	1.75E-04	1.42E-04
2070		2.94E-04	2.46E-04	1.78E-04	1.44E-04
2100		2.88E-04	2.48E-04	1.73E-04	1.47E-04
2130		2.68E-04	2.57E-04	1.71E-04	1.45E-04
2160		2.56E-04	2.48E-04	1.56E-04	1.44E-04
2190		2.63E-04	2.32E-04	1.50E-04	1.41E-04
2220		2.48E-04	2.31E-04	1.46E-04	1.40E-04
2250		2.36E-04	2.20E-04	1.47E-04	1.42E-04
2280		2.51E-04	2.20E-04	1.54E-04	1.44E-04
2310		2.36E-04	2.17E-04	1.53E-04	1.42E-04
2340		2.38E-04	2.16E-04	1.65E-04	1.42E-04
2370		2.49E-04	2.13E-04	1.74E-04	1.35E-04
2400		2.37E-04	2.14E-04	1.58E-04	1.35E-04
2430		2.64E-04	2.13E-04	1.55E-04	1.36E-04
2460		2.55E-04	2.12E-04	1.54E-04	1.35E-04
2490		2.38E-04	2.11E-04	1.55E-04	1.33E-04
2520		2.41E-04	2.10E-04	1.50E-04	1.35E-04
2550		2.44E-04	2.10E-04	1.49E-04	1.37E-04
2580		2.35E-04	2.09E-04	1.46E-04	1.34E-04
2610		2.45E-04	2.24E-04	1.48E-04	1.36E-04
2640		2.55E-04	2.25E-04	1.45E-04	1.33E-04
2670		2.51E-04	2.11E-04	1.42E-04	1.33E-04
2700		2.50E-04	2.12E-04	1.55E-04	1.33E-04
2730		2.47E-04	2.13E-04	1.57E-04	1.32E-04
2760		2.31E-04	2.13E-04	1.59E-04	1.16E-04
2790		2.42E-04	2.27E-04	1.57E-04	1.07E-04
2820		2.39E-04	2.11E-04	1.57E-04	1.19E-04
2850		2.22E-04	2.04E-04	1.56E-04	1.35E-04
2880		2.40E-04	2.08E-04	1.52E-04	1.23E-04
2910		2.37E-04	2.14E-04	1.49E-04	1.31E-04
2940		2.38E-04	2.08E-04	1.46E-04	1.41E-04
2970		2.38E-04	2.04E-04	1.44E-04	1.33E-04
3000		2.38E-04	2.04E-04	1.42E-04	1.29E-04

**FLIGHT NO. C-410**  
**TOTAL VOLUME SCATTERING COEFFICIENT**

(JOB 2022 DATE 06/09/78)  
 DATE 70477 FLIGHT NO. C-410 GROUND LEVEL ALTITUDE (M)= 45

ALTITUDE (M)	FILTERS	TOTAL VOLUME SCATTERING COEFFICIENT (PER M)			
		2	4	3	5
3030		2.36E-04	2.02E-04	1.43E-04	1.27E-04
3060		2.38E-04	2.06E-04	1.37E-04	1.25E-04
3090		2.32E-04	1.95E-04	1.30E-04	1.24E-04
3120		2.29E-04	2.22E-04	1.27E-04	1.23E-04
3150		2.30E-04	(2.21E-04 )	1.29E-04	1.22E-04
3180		2.30E-04	(2.20E-04 )	1.32E-04	1.23E-04
3210		(2.30E-04 )	(2.20E-04 )	(1.31E-04 )	(1.22E-04 )
3240		(2.29E-04 )	(2.19E-04 )	(1.31E-04 )	(1.22E-04 )
3270		(2.28E-04 )	(2.18E-04 )	(1.30E-04 )	(1.22E-04 )
3300		(2.27E-04 )	(2.18E-04 )	(1.30E-04 )	(1.21E-04 )
FIRST DATA ALT		150	120	180	150
LAST DATA ALT		3180	3120	3180	3180

**FLIGHT NO. C-410**  
**EQUIVALENT ATTENUATION LENGTH**

(JOB 2022 DATE 06/09/78)  
DATE 70477 FLIGHT NO. C-410 GROUND LEVEL ALTITUDE (M)= 45

ALTITUDE (M)	EQUIVALENT ATTENUATION LENGTH (M)				
	FILTERS	2	4	3	5
0		1.91E 03	3.00E 03	3.35E 03	5.18E 03
300		1.80E 03	2.88E 03	3.36E 03	5.17E 03
600		1.79E 03	2.79E 03	3.45E 03	5.04E 03
900		1.80E 03	2.69E 03	3.41E 03	4.78E 03
1200		1.87E 03	2.66E 03	3.37E 03	4.45E 03
1500		1.91E 03	2.57E 03	3.39E 03	4.37E 03
1800		1.98E 03	2.54E 03	3.50E 03	4.33E 03
2100		2.10E 03	2.67E 03	3.65E 03	4.39E 03
2400		2.23E 03	2.81E 03	3.86E 03	4.61E 03
2700		2.35E 03	2.94E 03	4.04E 03	4.81E 03
3000		2.46E 03	3.05E 03	4.21E 03	5.01E 03
3300		2.56E 03	3.15E 03	4.38E 03	5.19E 03

**FLIGHT NO. C-410**  
**VERTICAL BEAM TRANSMITTANCE FROM GROUND TO ALTITUDE**

ALTITUDE (M)	VERTICAL BEAM TRANSMITTANCE FROM GROUND TO ALTITUDE				
	FILTERS	2	4	3	5
0		1.00E 00	1.00E 00	1.00E 00	1.00E 00
300		8.47E-01	9.01E-01	9.15E-01	9.44E-01
600		7.16E-01	8.06E-01	8.40E-01	8.88E-01
900		6.07E-01	7.15E-01	7.68E-01	8.28E-01
1200		5.27E-01	6.37E-01	7.01E-01	7.64E-01
1500		4.56E-01	5.58E-01	6.43E-01	7.10E-01
1800		4.03E-01	4.93E-01	5.98E-01	6.60E-01
2100		3.68E-01	4.55E-01	5.63E-01	6.20E-01
2400		3.42E-01	4.25E-01	5.37E-01	5.94E-01
2700		3.17E-01	3.99E-01	5.13E-01	5.71E-01
3000		2.95E-01	3.74E-01	4.90E-01	5.49E-01
3300		2.75E-01	3.51E-01	4.71E-01	5.29E-01

FLIGHT C-411 - 6 JULY 1977 - DESCRIPTION OF FLIGHT & WEATHER CHARACTERISTICS

Filter Ident	Data Interval			Solar Zenith Angle			Maximum Flight Altitude (m)	Average Terrain Elevation (m)
	Start (GMT)	End (GMT)	Elapsed (hrs)	Initial ST&LV (degrees)	Solar Transit (degrees)	Final V-PRO (degrees)		
2 & 3	0902	0959	0.9	45.1	-	36.4	2875	46
4 & 5	1003	1113	1.2	35.9	-	27.8	2850	46

Flight C-411 was a morning flight. There were multiple cloud layers varying from scattered cumulus to broken cirrus.

The approximate east-west Bruz track was centered south of Rennes in northwestern France. Typical terrain features were green fields interspersed with patchwork gray and small towns.

The in-flight observer reported clear conditions east of Rennes and cloudy conditions to the west at the beginning of the flight. During the flight clouds moved in from the west starting with altocumulus and later with cumulus clouds forming and building. Heavy haze was observed at all altitudes.

Rennes, 7 kilometers north of the flight track center, reported altocumulus clouds at 3000 meters (10,000 feet) in amounts varying from 3/8 to 6/8. Cumulus formed at 1100 GMT at 690 meters (2300 feet) and gradually increased in amount to 2/8. Cirrus clouds were present at 7500 meters (25,000 feet) in amounts ranging from 4/8 to 6/8. Visibility was reported at 1.2 kilometers in light fog improving gradually to 6 kilometers.

Nantes/Chateau Bougon, 78 kilometers south of the track center point, reported clear skies in early morning with cumulus forming at 900 meters (3000 feet) at 1000 GMT. These clouds increased to 6/8 by 1200 GMT and had built up into cumulonimbus with ceilings at 1200 meters (4000 feet). Visibility of 5.0 kilometers gradually improved to 15.0 kilometers.

The radiosonde station at Brest was 208 kilometers westnorthwest of the flight track center and located in a prevailing airflow that was parallel with the track.

The surface chart showed a wave formation in the English channel with a cold front approaching the coast of France. The flow was easterly and the air mass was modified maritime polar and stable in advance of the front.

# FLIGHT NO. C-411

BRUZ

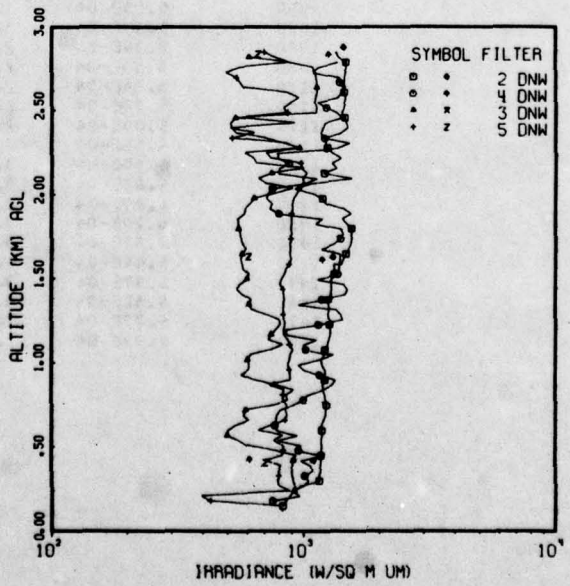
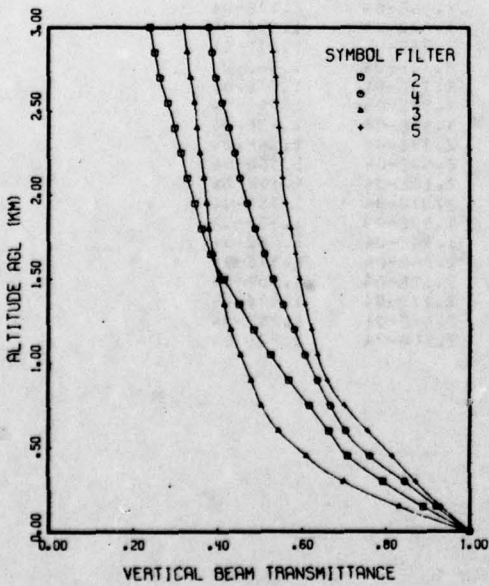
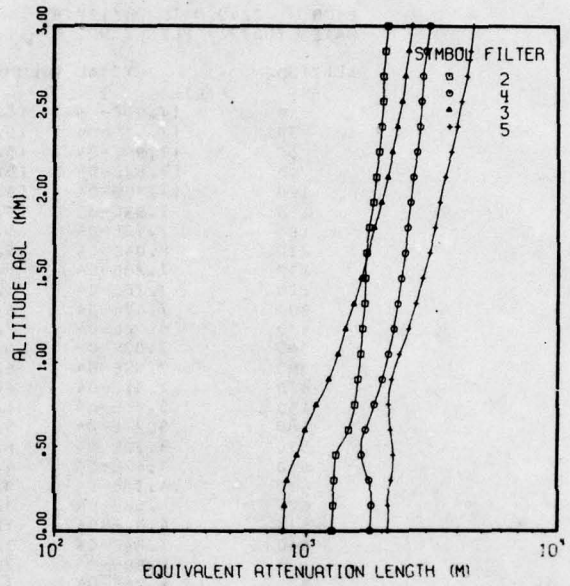
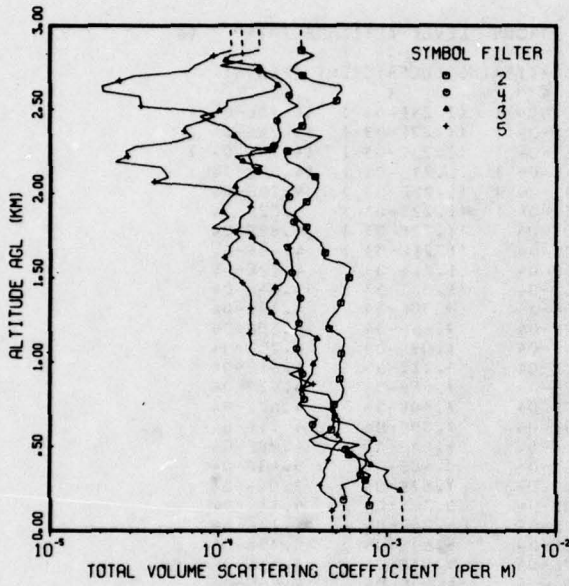

## FLIGHT NO. C-411 TOTAL VOLUME SCATTERING COEFFICIENT

(JOB 2240 DATE 06/12/78)  
DATE 70677 FLIGHT NO. C-411 GROUND LEVEL ALTITUDE (M)= 66

ALTITUDE (M)	TOTAL VOLUME SCATTERING COEFFICIENT (PER M)			
	FILTERS	2	4	3
0	(7.95E-04 )	(5.60E-04 )	(1.24E-03 )	(4.76E-04 )
30	(7.91E-04 )	(5.57E-04 )	(1.23E-03 )	(4.74E-04 )
60	(7.89E-04 )	(5.56E-04 )	(1.23E-03 )	(4.73E-04 )
90	(7.87E-04 )	(5.54E-04 )	(1.23E-03 )	(4.72E-04 )
120	(7.85E-04 )	(5.53E-04 )	(1.22E-03 )	4.70E-04
150	7.83E-04	(5.51E-04 )	(1.22E-03 )	5.02E-04
180	7.72E-04	5.50E-04	(1.22E-03 )	4.88E-04
210	8.04E-04	5.72E-04	(1.21E-03 )	4.43E-04
240	7.23E-04	5.61E-04	1.21E-03	4.12E-04
270	7.26E-04	5.44E-04	1.02E-03	4.04E-04
300	7.47E-04	6.76E-04	9.90E-04	4.19E-04
330	8.06E-04	7.02E-04	9.64E-04	4.30E-04
360	7.02E-04	6.94E-04	1.03E-03	4.25E-04
390	7.59E-04	6.94E-04	8.11E-04	4.41E-04
420	7.51E-04	6.82E-04	7.65E-04	4.52E-04
450	5.96E-04	6.47E-04	7.40E-04	4.67E-04
480	5.23E-04	5.69E-04	7.89E-04	4.71E-04
510	3.72E-04	6.91E-04	7.88E-04	4.98E-04
540	3.47E-04	4.58E-04	8.40E-04	5.43E-04
570	4.18E-04	3.95E-04	7.57E-04	5.04E-04
600	4.68E-04	3.59E-04	6.74E-04	5.17E-04
630	4.81E-04	3.62E-04	6.24E-04	5.18E-04
660	4.84E-04	3.87E-04	4.69E-04	5.19E-04
690	4.88E-04	3.37E-04	4.91E-04	4.81E-04
720	4.76E-04	3.26E-04	4.93E-04	4.70E-04
750	4.87E-04	3.04E-04	3.00E-04	4.68E-04
780	5.36E-04	3.25E-04	3.23E-04	4.65E-04
810	5.49E-04	3.25E-04	3.06E-04	4.49E-04
840	5.54E-04	3.12E-04	3.15E-04	3.07E-04
870	5.39E-04	3.12E-04	3.30E-04	3.66E-04
900	5.25E-04	3.08E-04	3.42E-04	3.09E-04
930	5.26E-04	3.17E-04	3.60E-04	2.64E-04
960	5.27E-04	3.11E-04	3.62E-04	3.19E-04
990	5.25E-04	3.19E-04	3.66E-04	2.13E-04
1020	5.39E-04	3.13E-04	3.87E-04	1.93E-04
1050	5.34E-04	2.97E-04	3.76E-04	1.61E-04
1080	5.50E-04	2.91E-04	3.77E-04	1.53E-04
1110	5.54E-04	2.98E-04	3.73E-04	1.57E-04
1140	5.53E-04	2.98E-04	3.85E-04	1.54E-04
1170	5.09E-04	2.85E-04	3.47E-04	1.53E-04
1200	4.56E-04	2.91E-04	2.73E-04	1.58E-04
1230	4.45E-04	3.02E-04	2.59E-04	1.56E-04
1260	4.63E-04	3.00E-04	2.19E-04	1.55E-04
1290	4.89E-04	2.95E-04	2.07E-04	1.55E-04
1320	5.20E-04	3.00E-04	1.95E-04	1.57E-04
1350	5.32E-04	3.02E-04	1.94E-04	1.56E-04
1380	5.44E-04	3.07E-04	2.06E-04	1.57E-04
1410	5.57E-04	3.02E-04	2.17E-04	1.55E-04
1440	5.62E-04	3.00E-04	2.17E-04	1.49E-04
1470	5.77E-04	2.93E-04	2.44E-04	1.39E-04
1500	5.93E-04	2.77E-04	2.50E-04	1.32E-04

## FLIGHT NO. C-411 TOTAL VOLUME SCATTERING COEFFICIENT

(JOB 2240 DATE 06/12/78)  
DATE 70677 FLIGHT NO. C-411 GROUND LEVEL ALTITUDE (M)= 45

ALTITUDE (M)	TOTAL VOLUME SCATTERING COEFFICIENT (PER M)				
	FILTERS	2	4	3	5
1530		5.96E-04	2.73E-04	2.55E-04	1.17E-04
1560		6.06E-04	2.73E-04	2.36E-04	1.18E-04
1590		5.35E-04	2.71E-04	2.20E-04	1.15E-04
1620		4.19E-04	2.69E-04	2.12E-04	1.08E-04
1650		4.27E-04	2.66E-04	2.05E-04	1.16E-04
1680		4.15E-04	2.57E-04	1.89E-04	1.16E-04
1710		4.05E-04	2.79E-04	1.67E-04	1.23E-04
1740		3.73E-04	2.89E-04	1.59E-04	1.35E-04
1770		3.35E-04	3.00E-04	1.55E-04	1.26E-04
1800		3.33E-04	2.97E-04	9.19E-05	1.34E-04
1830		3.08E-04	2.80E-04	1.04E-04	1.34E-04
1860		2.84E-04	2.91E-04	1.16E-04	1.36E-04
1890		2.85E-04	2.49E-04	1.06E-04	1.52E-04
1920		3.12E-04	2.45E-04	1.07E-04	1.55E-04
1950		3.32E-04	2.47E-04	1.12E-04	1.60E-04
1980		3.54E-04	2.62E-04	1.19E-04	1.49E-04
2010		3.72E-04	2.58E-04	1.29E-04	1.19E-04
2040		3.84E-04	2.80E-04	1.26E-04	9.80E-05
2070		3.90E-04	2.53E-04	1.27E-04	4.15E-05
2100		3.71E-04	2.23E-04	1.44E-04	5.01E-05
2130		3.32E-04	1.71E-04	1.60E-04	4.78E-05
2160		3.03E-04	1.58E-04	1.81E-04	4.50E-05
2190		2.57E-04	1.58E-04	1.40E-04	2.46E-05
2220		2.48E-04	1.52E-04	1.26E-04	2.89E-05
2250		2.55E-04	1.57E-04	2.19E-04	2.82E-05
2280		3.26E-04	2.14E-04	1.47E-04	3.26E-05
2310		3.68E-04	2.28E-04	1.36E-04	5.64E-05
2340		4.10E-04	2.33E-04	1.24E-04	6.91E-05
2370		2.73E-04	2.29E-04	1.20E-04	6.27E-05
2400		3.15E-04	2.26E-04	1.09E-04	6.44E-05
2430		3.27E-04	2.24E-04	8.95E-05	8.02E-05
2460		3.20E-04	2.28E-04	7.80E-05	9.49E-05
2490		3.44E-04	2.56E-04	1.01E-04	8.06E-05
2520		4.13E-04	2.97E-04	1.13E-04	3.47E-05
2550		5.01E-04	2.61E-04	1.12E-04	3.43E-05
2580		5.01E-04	2.62E-04	1.63E-04	3.40E-05
2610		5.36E-04	2.72E-04	2.13E-04	2.06E-05
2640		5.24E-04	2.61E-04	2.25E-04	2.03E-05
2670		3.62E-04	2.44E-04	2.13E-04	2.59E-05
2700		3.16E-04	2.18E-04	1.90E-04	3.16E-05
2730		2.71E-04	1.75E-04	1.84E-04	6.73E-05
2760		2.83E-04	1.02E-04	1.78E-04	7.24E-05
2790		3.15E-04	1.39E-04	1.11E-04	8.38E-05
2820		3.70E-04	(1.39E-04)	1.18E-04	9.38E-05
2850		3.10E-04	(1.38E-04)	1.75E-04	1.19E-04
2880		(3.09E-04)	(1.38E-04)	(1.74E-04)	(1.19E-04)
2910		(3.08E-04)	(1.37E-04)	(1.74E-04)	(1.18E-04)
2940		(3.07E-04)	(1.37E-04)	(1.73E-04)	(1.18E-04)
2970		(3.06E-04)	(1.37E-04)	(1.73E-04)	(1.18E-04)
3000		(3.05E-04)	(1.36E-04)	(1.72E-04)	(1.17E-04)

FIRST DATA ALT	150	180	240	120
LAST DATA ALT	2850	2790	2850	2850

**FLIGHT NO. C-411  
EQUIVALENT ATTENUATION LENGTH**

(JOB 2240 DATE 06/12/78)  
DATE 70677 FLIGHT NO. C-411 GROUND LEVEL ALTITUDE (M)= 46

ALTITUDE (M)	FILTERS	EQUIVALENT ATTENUATION LENGTH (M)			
		2	4	3	5
0		1.26E 03	1.79E 03	8.08E 02	2.10E 03
300		1.29E 03	1.78E 03	8.41E 02	2.18E 03
600		1.47E 03	1.71E 03	9.89E 02	2.15E 03
900		1.60E 03	2.00E 03	1.23E 03	2.18E 03
1200		1.67E 03	2.22E 03	1.43E 03	2.54E 03
1500		1.71E 03	2.38E 03	1.65E 03	2.90E 03
1800		1.78E 03	2.52E 03	1.86E 03	3.25E 03
2100		1.88E 03	2.65E 03	2.10E 03	3.55E 03
2400		1.99E 03	2.83E 03	2.30E 03	3.97E 03
2700		2.03E 03	2.92E 03	2.48E 03	4.36E 03
3000		2.10E 03	3.10E 03	2.64E 03	4.63E 03

**FLIGHT NO. C-411  
VERTICAL BEAM TRANSMITTANCE FROM GROUND TO ALTITUDE**

ALTITUDE (M)	FILTERS	VERTICAL BEAM TRANSMITTANCE FROM GROUND TO ALTITUDE			
		2	4	3	5
0		1.00E 00	1.00E 00	1.00E 00	1.00E 00
300		7.93E-01	8.45E-01	7.00E-01	8.72E-01
600		6.65E-01	7.05E-01	5.45E-01	7.57E-01
900		5.71E-01	6.38E-01	4.81E-01	6.62E-01
1200		4.87E-01	5.82E-01	4.32E-01	6.24E-01
1500		4.16E-01	5.33E-01	4.04E-01	5.96E-01
1800		3.63E-01	4.90E-01	3.81E-01	5.75E-01
2100		3.28E-01	4.53E-01	3.68E-01	5.54E-01
2400		2.99E-01	4.28E-01	3.52E-01	5.46E-01
2700		2.64E-01	3.96E-01	3.37E-01	5.38E-01
3000		2.40E-01	3.80E-01	3.20E-01	5.23E-01

**FLIGHT C-412 - 7 JULY 1977 - DESCRIPTION OF FLIGHT & WEATHER CHARACTERISTICS**

Filter Ident	Data Interval			Solar Zenith Angle			Maximum Flight Altitude (m)	Average Terrain Elevation (m)
	Start (GMT)	End (GMT)	Elapsed (hrs)	Initial ST&LV (degrees)	Solar Transit (degrees)	Final V-PRO (degrees)		
2 & 3	0845	1036	1.9	48.0	-	31.7	5640	46
4 & 5	1043	1233	1.8	31.0	25.4	25.8	5640	46

Flight C-412 was a midday flight, spanning local apparent noon. There were mostly clear skies with cumulus building up near noon. The in-flight pictures indicated that the flight was conducted in the clear portions of the area.

The approximate east-west Bruz track was centered south of Rennes in northwestern France. Typical terrain features were green and brown fields interspersed with small towns.

The in-flight observer reported clear skies at the beginning of the flight with scattered clouds forming at 0915 GMT over the west end of the track. These scattered clouds gradually invaded the entire track. Heavy haze was observed at all altitudes. Clouds had been noted south of the track at the outset.

Rennes, 7 kilometers north of the flight track center, reported 1/8 to 2/8 cirrus at 7500 meters (25,000 feet) until 1000 GMT. After 1100 GMT there was cumulus at 900 to 1080 meters (3000 to 3600 feet) in amounts varying from 1/8 to 4/8. Visibility was reported as 6.0 kilometers gradually improving to 9.0 kilometers.

Nantes/Chateau Bougon, 78 kilometers south of the track center point, reported 5/8 alto-cumulus at 3000 meters (10,000 feet) and 6/8 cirrus at 7500 meters (25,000 feet) at 0800 GMT. The broken altocumulus layer lowered to 2400 meters (8000 feet) and scattered cumulus formed after 1100 GMT at 1200 meters (4000 feet). The cumulus varied in amount from 1/8 to 3/8. Visibility was reported at 6.0 to 9.0 kilometers.

The radiosonde station at Brest was 208 kilometers westnorthwest of the flight track center and located in a prevailing airflow that was parallel to the track.

The surface chart showed a wave formation with the warm front extending from Lyon east-northeastward through Switzerland into Germany. The cold front part of this system extended along a line from Lyon-Ibiza-Balearic Islands. This frontal system was in a trough without closed isobars. The 500 millibar chart had a low in the central part of the northwestern Spain. Another low in Finland was stationary and decreasing in intensity. The track, as well as all of France, was in the trough between the two lows. The flow at all levels was easterly and the air mass was modified unstable maritime polar.

# FLIGHT NO. C-412

BRUZ

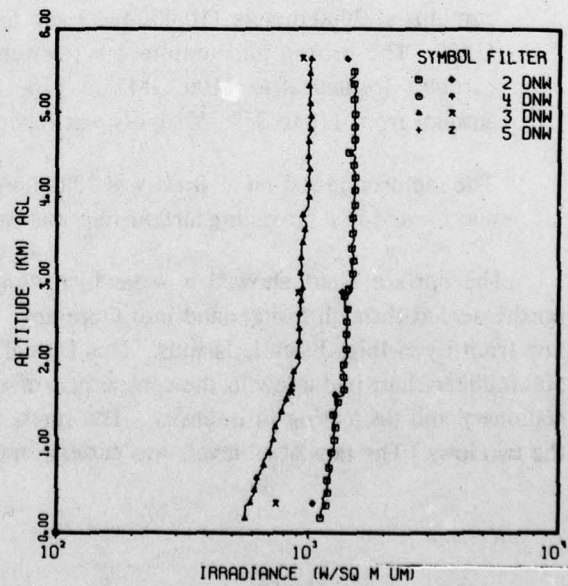
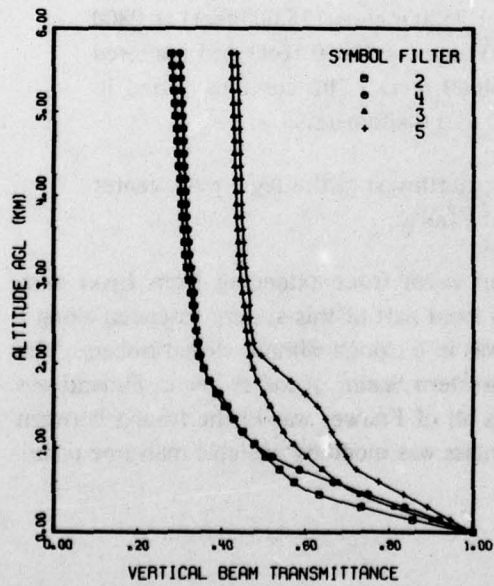
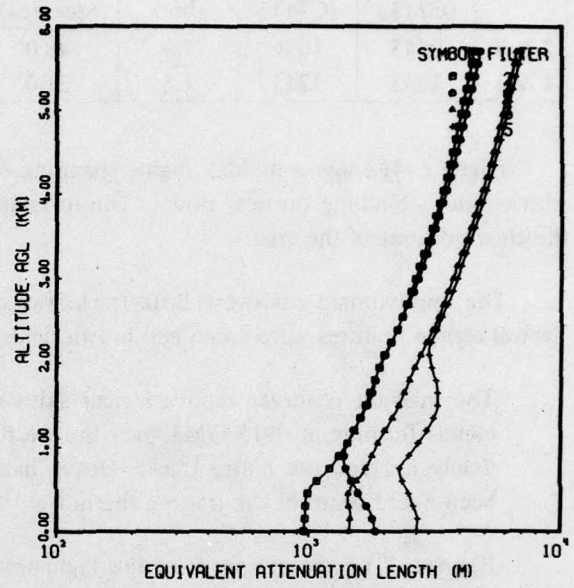
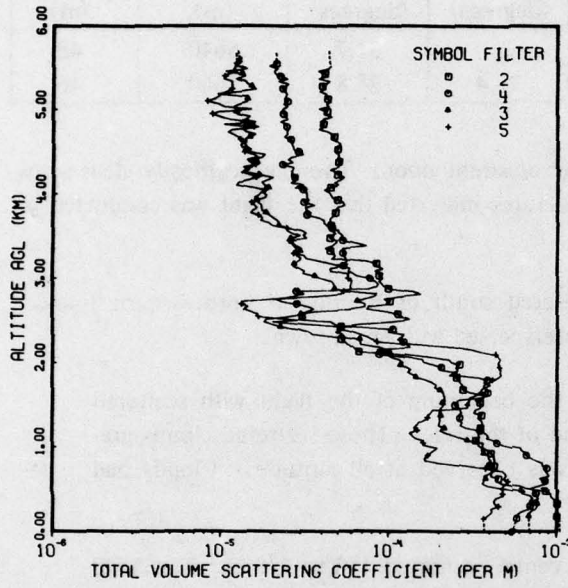

## FLIGHT NO. C-412 TOTAL VOLUME SCATTERING COEFFICIENT

(JOB 9412 DATE 06/15/78)  
DATE 70777 FLIGHT NO. C-412 GROUND LEVEL ALTITUDE (M)= 46

ALTITUDE (M)	TOTAL VOLUME SCATTERING COEFFICIENT (PER M)			
	FILTERS	2	4	3
0	(1.05E-03)	5.45E-04	6.94E-04	13.74E-04
30	(1.04E-03)	5.52E-04	6.90E-04	13.72E-04
60	(1.04E-03)	5.59E-04	6.88E-04	13.71E-04
90	(1.04E-03)	5.65E-04	6.87E-04	13.70E-04
120	(1.04E-03)	5.72E-04	6.85E-04	13.69E-04
150	(1.03E-03)	5.79E-04	6.83E-04	13.68E-04
180	1.03E-03	5.86E-04	6.82E-04	13.66E-04
210	1.04E-03	5.93E-04	6.84E-04	13.60E-04
240	1.04E-03	6.29E-04	7.04E-04	14.13E-04
270	1.03E-03	6.94E-04	7.53E-04	14.06E-04
300	1.02E-03	6.94E-04	7.58E-04	14.49E-04
330	1.01E-03	7.17E-04	7.63E-04	14.27E-04
360	1.07E-03	7.20E-04	6.82E-04	14.21E-04
390	9.43E-04	7.76E-04	7.21E-04	14.31E-04
420	9.14E-04	7.59E-04	6.96E-04	14.65E-04
450	9.11E-04	7.47E-04	6.16E-04	14.76E-04
480	8.53E-04	7.26E-04	6.18E-04	14.71E-04
510	6.69E-04	7.05E-04	5.00E-04	14.73E-04
540	6.05E-04	7.83E-04	3.92E-04	14.87E-04
570	4.80E-04	8.75E-04	3.63E-04	15.04E-04
600	4.38E-04	8.60E-04	3.71E-04	15.17E-04
630	4.55E-04	7.94E-04	3.81E-04	14.84E-04
660	4.09E-04	9.07E-04	3.74E-04	15.05E-04
690	4.13E-04	8.83E-04	4.01E-04	14.98E-04
720	4.14E-04	8.58E-04	4.28E-04	14.75E-04
750	4.24E-04	8.78E-04	4.06E-04	13.80E-04
780	4.26E-04	8.25E-04	3.97E-04	12.90E-04
810	4.23E-04	8.25E-04	3.86E-04	12.04E-04
840	4.30E-04	7.55E-04	4.11E-04	1.65E-04
870	4.26E-04	6.98E-04	3.94E-04	1.65E-04
900	4.22E-04	6.60E-04	3.96E-04	1.72E-04
930	4.07E-04	6.49E-04	3.69E-04	1.78E-04
960	3.93E-04	6.15E-04	3.59E-04	1.87E-04
990	3.66E-04	6.08E-04	3.60E-04	1.95E-04
1020	3.42E-04	4.91E-04	3.62E-04	1.65E-04
1050	3.41E-04	4.41E-04	3.64E-04	1.61E-04
1080	3.29E-04	4.21E-04	2.94E-04	1.57E-04
1110	3.46E-04	3.80E-04	2.69E-04	1.43E-04
1140	3.46E-04	3.93E-04	2.45E-04	1.38E-04
1170	3.44E-04	3.75E-04	2.20E-04	1.34E-04
1200	3.37E-04	3.53E-04	2.02E-04	1.49E-04
1230	3.54E-04	2.89E-04	2.16E-04	1.42E-04
1260	3.60E-04	2.66E-04	1.99E-04	1.48E-04
1290	3.63E-04	2.76E-04	2.01E-04	1.51E-04
1320	3.57E-04	2.60E-04	2.03E-04	1.64E-04
1350	3.39E-04	2.66E-04	2.00E-04	1.71E-04
1380	3.59E-04	2.64E-04	2.05E-04	1.73E-04
1410	3.20E-04	2.72E-04	2.01E-04	1.79E-04
1440	3.28E-04	2.68E-04	2.04E-04	1.84E-04
1470	3.52E-04	2.60E-04	2.05E-04	2.96E-04
1500	3.53E-04	2.49E-04	2.12E-04	2.94E-04

## FLIGHT NO. C-412 TOTAL VOLUME SCATTERING COEFFICIENT

(JOB 9412 DATE 06/15/78)  
DATE 70777 FLIGHT NO. C-412 GROUND LEVEL ALTITUDE (M)= 46

ALTITUDE (M)	TOTAL VOLUME SCATTERING COEFFICIENT (PER M)				
	FILTERS	2	4	3	5
1530		3.50E-04	2.56E-04	2.10E-04	3.00E-04
1560		3.27E-04	2.57E-04	2.17E-04	3.02E-04
1590		3.66E-04	3.55E-04	2.14E-04	3.06E-04
1620		3.65E-04	3.91E-04	2.12E-04	3.33E-04
1650		3.05E-04	3.89E-04	2.10E-04	3.56E-04
1680		2.76E-04	3.86E-04	2.02E-04	3.52E-04
1710		2.82E-04	3.69E-04	1.87E-04	3.70E-04
1740		2.71E-04	4.02E-04	1.91E-04	3.67E-04
1770		2.67E-04	3.68E-04	1.81E-04	3.97E-04
1800		2.64E-04	3.89E-04	1.66E-04	4.16E-04
1830		2.54E-04	3.41E-04	1.45E-04	4.52E-04
1860		2.41E-04	2.30E-04	1.39E-04	4.69E-04
1890		2.46E-04	2.56E-04	1.29E-04	4.59E-04
1920		2.59E-04	2.05E-04	1.36E-04	4.65E-04
1950		2.50E-04	2.06E-04	1.27E-04	4.57E-04
1980		2.66E-04	1.83E-04	1.18E-04	4.50E-04
2010		2.36E-04	1.61E-04	1.21E-04	4.46E-04
2040		2.28E-04	1.59E-04	1.15E-04	4.63E-04
2070		1.79E-04	1.31E-04	1.03E-04	4.48E-04
2100		1.27E-04	8.74E-05	9.79E-05	4.32E-04
2130		6.61E-05	9.63E-05	1.01E-04	3.53E-04
2160		6.33E-05	8.53E-05	9.62E-05	3.06E-04
2190		6.06E-05	1.34E-04	8.65E-05	2.43E-04
2220		5.70E-05	1.26E-04	6.75E-05	1.45E-04
2250		5.44E-05	1.22E-04	6.72E-05	8.49E-05
2280		5.19E-05	1.12E-04	6.68E-05	7.89E-05
2310		5.37E-05	1.19E-04	4.87E-05	7.37E-05
2340		5.29E-05	1.22E-04	3.47E-05	6.66E-05
2370		4.79E-05	9.85E-05	3.31E-05	5.96E-05
2400		5.30E-05	1.06E-04	2.87E-05	5.10E-05
2430		5.18E-05	5.76E-05	2.27E-05	5.17E-05
2460		6.86E-05	3.18E-05	2.01E-05	4.77E-05
2490		1.03E-04	2.04E-05	1.80E-05	4.50E-05
2520		1.33E-04	3.09E-05	1.87E-05	2.54E-05
2550		1.18E-04	3.06E-05	2.45E-05	1.67E-05
2580		1.14E-04	3.02E-05	3.02E-05	1.65E-05
2610		9.84E-05	3.31E-05	3.64E-05	1.51E-05
2640		7.39E-05	3.60E-05	5.98E-05	1.37E-05
2670		7.62E-05	3.26E-05	7.24E-05	1.46E-05
2700		9.93E-05	2.84E-05	7.25E-05	1.34E-05
2730		1.02E-04	2.33E-05	5.52E-05	1.35E-05
2760		9.40E-05	2.11E-05	7.23E-05	1.99E-05
2790		1.16E-04	2.61E-05	8.21E-05	3.59E-05
2820		1.54E-04	3.14E-05	8.45E-05	5.20E-05
2850		1.38E-04	2.82E-05	5.40E-05	5.38E-05
2880		9.93E-05	7.62E-05	4.77E-05	5.95E-05
2910		9.33E-05	8.50E-05	4.79E-05	5.88E-05
2940		9.04E-05	8.63E-05	4.67E-05	5.94E-05
2970		8.75E-05	8.17E-05	4.55E-05	6.01E-05
3000		8.98E-05	7.72E-05	3.94E-05	5.73E-05

**FLIGHT NO. C-412**  
**TOTAL VOLUME SCATTERING COEFFICIENT**

(JOB 9412 DATE 06/15/78)  
 DATE 70777 FLIGHT NO. C-412 GROUND LEVEL ALTITUDE (M)= 46

ALTITUDE (M)	TOTAL VOLUME SCATTERING COEFFICIENT (PER M)				
	FILTERS	2	4	3	5
3030		8.78E-05	6.44E-05	3.64E-05	5.75E-05
3060		9.29E-05	6.09E-05	3.08E-05	5.77E-05
3090		8.29E-05	5.74E-05	3.16E-05	4.52E-05
3120		9.30E-05	5.87E-05	2.93E-05	4.48E-05
3150		8.27E-05	5.39E-05	2.70E-05	5.26E-05
3180		8.50E-05	5.53E-05	2.74E-05	4.54E-05
3210		7.32E-05	5.62E-05	2.92E-05	3.82E-05
3240		4.57E-05	5.55E-05	3.02E-05	3.21E-05
3270		4.79E-05	5.42E-05	2.84E-05	3.15E-05
3300		4.71E-05	5.32E-05	2.90E-05	2.72E-05
3330		4.48E-05	5.44E-05	2.97E-05	2.77E-05
3360		4.17E-05	5.32E-05	2.94E-05	2.83E-05
3390		4.60E-05	7.35E-05	2.79E-05	2.72E-05
3420		4.77E-05	6.32E-05	2.70E-05	2.64E-05
3450		4.95E-05	5.29E-05	2.64E-05	2.55E-05
3480		4.46E-05	5.18E-05	2.60E-05	3.24E-05
3510		4.58E-05	5.30E-05	2.96E-05	3.07E-05
3540		4.80E-05	5.00E-05	2.63E-05	3.22E-05
3570		4.54E-05	4.98E-05	2.47E-05	2.98E-05
3600		4.55E-05	4.56E-05	2.49E-05	2.47E-05
3630		4.55E-05	4.25E-05	2.23E-05	2.02E-05
3660		4.38E-05	4.14E-05	2.21E-05	1.95E-05
3690		4.52E-05	4.15E-05	2.18E-05	1.73E-05
3720		4.51E-05	3.82E-05	2.05E-05	1.77E-05
3750		4.72E-05	3.25E-05	1.96E-05	1.67E-05
3780		4.81E-05	3.45E-05	1.86E-05	1.50E-05
3810		4.80E-05	3.23E-05	1.75E-05	1.57E-05
3840		4.93E-05	3.18E-05	1.74E-05	1.64E-05
3870		5.46E-05	3.62E-05	1.74E-05	1.57E-05
3900		5.35E-05	3.13E-05	1.67E-05	1.53E-05
3930		4.96E-05	3.34E-05	1.63E-05	1.63E-05
3960		4.60E-05	3.24E-05	1.58E-05	1.84E-05
3990		4.50E-05	3.24E-05	1.67E-05	1.87E-05
4020		4.40E-05	3.23E-05	1.73E-05	1.77E-05
4050		4.10E-05	3.09E-05	1.87E-05	1.83E-05
4080		4.47E-05	2.75E-05	1.92E-05	1.53E-05
4110		5.00E-05	3.09E-05	1.81E-05	1.23E-05
4140		4.71E-05	2.59E-05	1.74E-05	1.27E-05
4170		5.15E-05	2.84E-05	1.89E-05	1.44E-05
4200		5.37E-05	2.73E-05	2.03E-05	1.62E-05
4230		4.91E-05	2.61E-05	1.68E-05	1.51E-05
4260		4.97E-05	2.63E-05	1.40E-05	1.32E-05
4290		4.45E-05	2.69E-05	1.40E-05	1.48E-05
4320		5.00E-05	2.72E-05	1.52E-05	1.36E-05
4350		5.05E-05	2.33E-05	1.58E-05	1.61E-05
4380		5.03E-05	2.68E-05	1.64E-05	1.49E-05
4410		5.19E-05	2.50E-05	1.47E-05	1.43E-05
4440		4.97E-05	2.65E-05	1.76E-05	1.66E-05
4470		4.99E-05	3.09E-05	1.83E-05	1.56E-05
4500		4.80E-05	2.90E-05	1.48E-05	1.38E-05

## FLIGHT NO. C-412 TOTAL VOLUME SCATTERING COEFFICIENT

(JOB 9412 DATE 06/15/78)  
DATE 70777 FLIGHT NO. C-412 GROUND LEVEL ALTITUDE (M)= 46

ALTITUDE (M)	FILTERS	TOTAL VOLUME SCATTERING COEFFICIENT (PER M)			
		2	4	3	5
4530	4.94E-05	2.71E-05	1.41E-05	1.51E-05	
4560	5.03E-05	2.69E-05	1.33E-05	1.41E-05	
4590	5.12E-05	2.64E-05	1.30E-05	1.38E-05	
4620	4.92E-05	2.63E-05	1.43E-05	1.35E-05	
4650	4.63E-05	2.61E-05	1.39E-05	1.32E-05	
4680	4.74E-05	2.39E-05	1.49E-05	1.27E-05	
4710	4.60E-05	2.50E-05	1.61E-05	1.19E-05	
4740	4.34E-05	2.49E-05	1.41E-05	1.10E-05	
4770	3.83E-05	2.48E-05	1.34E-05	1.18E-05	
4800	4.08E-05	2.46E-05	1.67E-05	1.57E-05	
4830	4.07E-05	2.47E-05	1.44E-05	1.05E-05	
4860	4.00E-05	2.26E-05	1.31E-05	1.60E-05	
4890	4.05E-05	2.48E-05	1.44E-05	1.13E-05	
4920	4.61E-05	2.47E-05	1.50E-05	9.85E-06	
4950	4.09E-05	2.36E-05	1.26E-05	8.97E-06	
4980	4.30E-05	2.40E-05	1.24E-05	9.85E-06	
5010	3.84E-05	2.33E-05	1.28E-05	1.53E-05	
5040	4.39E-05	2.51E-05	1.20E-05	1.04E-05	
5070	4.26E-05	2.37E-05	1.30E-05	9.76E-06	
5100	4.48E-05	2.50E-05	1.44E-05	8.34E-06	
5130	4.32E-05	2.39E-05	1.44E-05	9.13E-06	
5160	4.17E-05	2.44E-05	1.45E-05	9.71E-06	
5190	4.24E-05	2.49E-05	9.58E-06	1.01E-05	
5220	3.87E-05	2.41E-05	1.28E-05	1.09E-05	
5250	4.11E-05	2.33E-05	1.62E-05	1.16E-05	
5280	4.00E-05	2.42E-05	1.53E-05	1.16E-05	
5310	4.22E-05	2.92E-05	1.44E-05	1.15E-05	
5340	4.43E-05	2.20E-05	1.39E-05	1.16E-05	
5370	3.80E-05	2.50E-05	1.23E-05	1.04E-05	
5400	4.22E-05	2.25E-05	1.39E-05	1.06E-05	
5430	4.14E-05	2.10E-05	1.33E-05	1.10E-05	
5460	3.78E-05	2.06E-05	1.07E-05	1.23E-05	
5490	4.33E-05	2.17E-05	1.43E-05	1.19E-05	
5520	4.47E-05	1.93E-05	1.27E-05	1.22E-05	
5550	(4.46E-05 )	2.16E-05	1.23E-05	1.25E-05	
5580	(4.45E-05 )	(2.15E-05 )	1.28E-05	(1.24E-05 )	
5610	(4.43E-05 )	(2.15E-05 )	1.33E-05	(1.24E-05 )	
5640	(4.42E-05 )	(2.14E-05 )	1.28E-05	(1.23E-05 )	
5670	(4.40E-05 )	(2.13E-05 )	(1.27E-05 )	(1.23E-05 )	
5700	(4.39E-05 )	(2.13E-05 )	(1.27E-05 )	(1.23E-05 )	
FIRST DATA ALT	180	0	180	150	
LAST DATA ALT	5520	5550	5640	5550	

**FLIGHT NO. C-412**  
**EQUIVALENT ATTENUATION LENGTH**

(JOB 9412 DATE 06/15/78)  
DATE 70777 FLIGHT NO. C-412 GROUND LEVEL ALTITUDE (M)= 46

ALTITUDE (M)	EQUIVALENT ATTENUATION LENGTH (M)			
	FILTERS	2	4	3
0	9.53E 02	1.83E 03	1.44E 03	2.57E 03
300	9.65E 02	1.68E 03	1.43E 03	2.59E 03
600	1.08E 03	1.48E 03	1.55E 03	2.35E 03
900	1.32E 03	1.38E 03	1.78E 03	2.50E 03
1200	1.52E 03	1.50E 03	2.00E 03	2.93E 03
1500	1.67E 03	1.71E 03	2.27E 03	3.23E 03
1800	1.82E 03	1.83E 03	2.49E 03	3.17E 03
2100	1.98E 03	2.00E 03	2.76E 03	2.99E 03
2400	2.23E 03	2.22E 03	3.08E 03	3.19E 03
2700	2.44E 03	2.47E 03	3.42E 03	3.55E 03
3000	2.64E 03	2.71E 03	3.71E 03	3.87E 03
3300	2.84E 03	2.93E 03	4.04E 03	4.19E 03
3600	3.07E 03	3.15E 03	4.36E 03	4.52E 03
3900	3.28E 03	3.38E 03	4.69E 03	4.86E 03
4200	3.49E 03	3.62E 03	5.02E 03	5.21E 03
4500	3.70E 03	3.85E 03	5.35E 03	5.55E 03
4800	3.90E 03	4.08E 03	5.67E 03	5.89E 03
5100	4.10E 03	4.30E 03	6.00E 03	6.23E 03
5400	4.30E 03	4.53E 03	6.32E 03	6.57E 03
5700	4.49E 03	4.76E 03	6.64E 03	6.91E 03

**FLIGHT NO. C-412**  
**VERTICAL BEAM TRANSMITTANCE FROM GROUND TO ALTITUDE**

ALTITUDE (M)	VERTICAL BEAM TRANSMITTANCE FROM GROUND TO ALTITUDE			
	FILTERS	2	4	3
0	1.00E 00	1.00E 00	1.00E 00	1.00E 00
300	7.33E-01	8.37E-01	8.11E-01	8.90E-01
600	5.73E-01	6.66E-01	6.79E-01	7.75E-01
900	5.05E-01	5.21E-01	6.03E-01	6.97E-01
1200	4.53E-01	4.50E-01	5.49E-01	6.64E-01
1500	4.08E-01	4.15E-01	5.16E-01	6.29E-01
1800	3.72E-01	3.74E-01	4.86E-01	5.67E-01
2100	3.46E-01	3.51E-01	4.68E-01	4.95E-01
2400	3.40E-01	3.39E-01	4.59E-01	4.71E-01
2700	3.31E-01	3.35E-01	4.54E-01	4.57E-01
3000	3.21E-01	3.30E-01	4.46E-01	4.61E-01
3300	3.13E-01	3.25E-01	4.42E-01	4.55E-01
3600	3.09E-01	3.19E-01	4.38E-01	4.51E-01
3900	3.05E-01	3.16E-01	4.35E-01	4.49E-01
4200	3.00E-01	3.13E-01	4.33E-01	4.46E-01
4500	2.96E-01	3.10E-01	4.31E-01	4.44E-01
4800	2.92E-01	3.08E-01	4.29E-01	4.43E-01
5100	2.88E-01	3.06E-01	4.27E-01	4.41E-01
5400	2.85E-01	3.04E-01	4.26E-01	4.40E-01
5700	2.81E-01	3.02E-01	4.24E-01	4.38E-01

FLIGHT C-413 - 27 JULY 1977 - DESCRIPTION OF FLIGHT & WEATHER CHARACTERISTICS

Filter Ident	Data Interval			Solar Zenith Angle			Maximum Flight Altitude (m)	Average Terrain Elevation (m)
	Start (GMT)	End (GMT)	Elapsed (hrs)	Initial ST&LV (degrees)	Solar Transit (degrees)	Final V-PRO (degrees)		
3	1441	1455	0.2	51.7	-	53.7	5670	0
4	1458	1517	0.3	54.0	-	56.8	5580	0
5	1525	1540	0.3	57.7	-	59.9	5700	0
2	1543	1603	0.3	60.2	-	63.3	5340	0

Flight C-413 was an afternoon flight. There were multiple layers of scattered to broken clouds which increased at times to overcast.

The approximate southeast to northwest Rodby track was located south of Lolland Island, Denmark. Typical terrain features along the nearby coast to the north of the track were flat cultivated farmlands interspersed with occasional woods and small towns. Directly beneath the track and to the south were the relatively shallow waters of Femer Bay.

The in-flight observer reported scattered cumulus with bases 450 meters (1500 feet), scattered variable broken clouds at 1650 meters (5500 feet) and broken clouds at 5100 meters (17,000 feet). Precipitation was noted under the middle cloud deck. At the beginning of the flight the atmosphere was clear with good visibility. A haze layer was noted during the second climb and continued for the duration of the flight.

Fehmarnbelt, 9 kilometers south of the track center point, reported stratocumulus varying from 4/8 to 6/8 at 300 meters (1000 feet) with overcast altocumulus at 3000 meters (10,000 feet). Visibility was 20.0 kilometers with light rain showers observed about noon.

Kegnaes, 76 kilometers westnorthwest of the track center point, reported 5/8 of cumulonimbus decreasing to 3/8 at altitudes varying from 630 to 720 meters (2100 to 2400 feet) and 7/8 altocumulus at 3000 meters (10,000 feet) gradually decreasing to 4/8 coverage. Visibility of 15.0 kilometers in light rain showers gradually improved to 20.0 kilometers.

The radiosonde station at Schleswig was 103 kilometers west of the flight track center and located in a prevailing flow that was upstream of the flight track.

The surface chart had a stationary low over Bergen that was filling slowly. An occluded front extended from central Belgium southsouthwestward through France to the Bay of Biscay. At 500 millibars a large closed low was located over the North Sea west of Bergen. With lows at the surface and 500 millibars cold moist air was being advected into the area at all levels. The flow was southwesterly and the air mass was unstable maritime polar.

# FLIGHT NO. C-413

RODBY

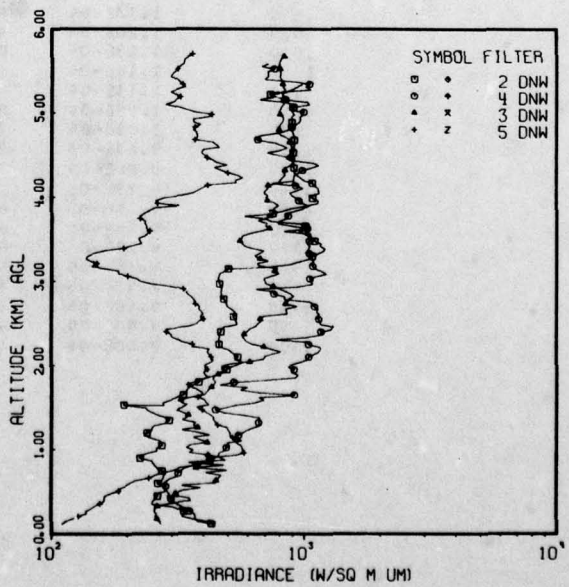
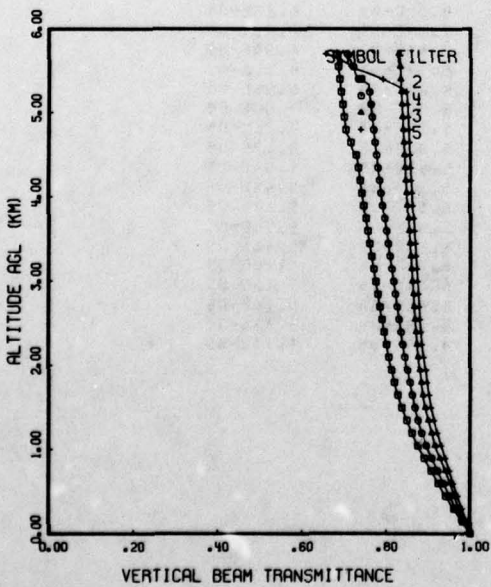
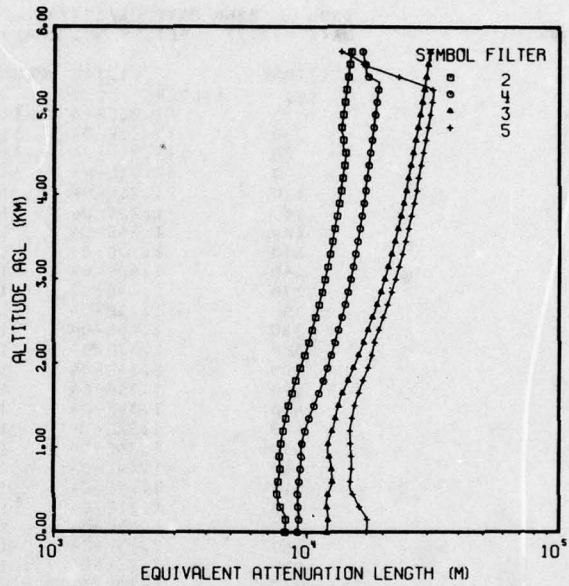
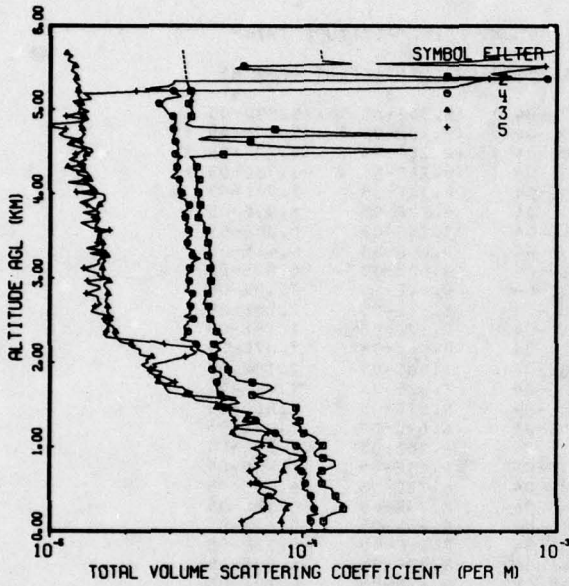

## FLIGHT NO. C-413 TOTAL VOLUME SCATTERING COEFFICIENT

(JOB 2364 DATE 06/12/78)  
DATE 72777 FLIGHT NO. C-413 GROUND LEVEL ALTITUDE (M)= 0

ALTITUDE (M)	TOTAL VOLUME SCATTERING COEFFICIENT (PER M)			
	FILTERS	2	4	3
0	(1.22E-04 )	(1.09E-04 )	(8.34E-05 )	(5.82E-05 )
30	(1.22E-04 )	(1.09E-04 )	(8.30E-05 )	(5.79E-05 )
60	(1.21E-04 )	(1.08E-04 )	(8.28E-05 )	(5.77E-05 )
90	(1.21E-04 )	(1.08E-04 )	(8.26E-05 )	(5.76E-05 )
120	1.21E-04	1.08E-04	8.24E-05	5.74E-05
150	1.22E-04	1.05E-04	8.22E-05	5.99E-05
180	1.24E-04	1.05E-04	8.29E-05	6.28E-05
210	1.30E-04	1.15E-04	8.46E-05	6.41E-05
240	1.40E-04	1.11E-04	8.50E-05	6.83E-05
270	1.44E-04	1.11E-04	8.61E-05	7.10E-05
300	1.41E-04	1.10E-04	8.57E-05	7.28E-05
330	1.46E-04	1.11E-04	9.12E-05	7.19E-05
360	1.37E-04	1.08E-04	8.06E-05	7.07E-05
390	1.36E-04	1.08E-04	7.90E-05	7.18E-05
420	1.35E-04	1.08E-04	7.32E-05	7.51E-05
450	1.34E-04	1.06E-04	6.87E-05	7.80E-05
480	1.32E-04	1.05E-04	6.69E-05	7.93E-05
510	1.30E-04	1.01E-04	6.86E-05	7.55E-05
540	1.19E-04	1.01E-04	5.91E-05	6.98E-05
570	1.19E-04	1.03E-04	6.73E-05	6.25E-05
600	1.21E-04	1.04E-04	8.23E-05	6.53E-05
630	1.19E-04	1.01E-04	8.20E-05	6.61E-05
660	1.15E-04	1.03E-04	8.16E-05	6.38E-05
690	1.15E-04	1.04E-04	8.33E-05	6.33E-05
720	1.20E-04	9.94E-05	8.42E-05	6.19E-05
750	1.28E-04	9.35E-05	8.42E-05	6.53E-05
780	1.35E-04	9.69E-05	8.48E-05	6.81E-05
810	1.34E-04	9.98E-05	8.49E-05	6.48E-05
840	1.33E-04	1.01E-04	9.41E-05	7.04E-05
870	1.21E-04	1.01E-04	9.99E-05	6.74E-05
900	1.12E-04	1.01E-04	1.00E-04	7.20E-05
930	1.12E-04	1.03E-04	8.93E-05	6.78E-05
960	1.13E-04	1.01E-04	8.56E-05	6.72E-05
990	1.18E-04	9.90E-05	8.00E-05	6.28E-05
1020	1.20E-04	9.46E-05	7.49E-05	6.92E-05
1050	1.13E-04	9.50E-05	7.44E-05	6.94E-05
1080	1.16E-04	8.20E-05	6.37E-05	6.91E-05
1110	1.13E-04	8.30E-05	5.85E-05	6.95E-05
1140	1.08E-04	8.20E-05	5.32E-05	7.00E-05
1170	1.01E-04	7.81E-05	5.29E-05	7.32E-05
1200	9.63E-05	7.55E-05	5.38E-05	6.92E-05
1230	9.86E-05	7.17E-05	5.53E-05	5.39E-05
1260	9.75E-05	6.94E-05	5.55E-05	5.43E-05
1290	9.15E-05	6.71E-05	6.57E-05	5.37E-05
1320	9.75E-05	6.54E-05	5.96E-05	5.36E-05
1350	9.19E-05	6.47E-05	5.22E-05	5.41E-05
1380	9.16E-05	5.99E-05	6.00E-05	5.18E-05
1410	9.51E-05	6.04E-05	6.33E-05	5.16E-05
1440	9.46E-05	5.30E-05	5.46E-05	5.16E-05
1470	9.40E-05	4.92E-05	4.58E-05	5.16E-05
1500	9.60E-05	4.83E-05	4.96E-05	4.73E-05

**FLIGHT NO. C-413**  
**TOTAL VOLUME SCATTERING COEFFICIENT**

(JOB 2364 DATE 06/12/78)  
 DATE 72777 FLIGHT NO. C-413 GROUND LEVEL ALTITUDE (M)= 0

ALTITUDE (M)	TOTAL VOLUME SCATTERING COEFFICIENT (PER M)				
	FILTERS	2	4	3	5
1530		8.33E-05	4.74E-05	5.64E-05	4.59E-05
1560		8.10E-05	4.87E-05	5.40E-05	3.78E-05
1590		6.90E-05	5.43E-05	4.56E-05	3.68E-05
1620		6.31E-05	4.74E-05	3.45E-05	3.55E-05
1650		7.06E-05	4.62E-05	2.95E-05	3.67E-05
1680		7.42E-05	4.60E-05	2.90E-05	3.43E-05
1710		7.67E-05	4.58E-05	2.86E-05	3.35E-05
1740		7.39E-05	4.56E-05	2.96E-05	2.80E-05
1770		6.32E-05	4.58E-05	2.69E-05	3.13E-05
1800		5.49E-05	4.62E-05	2.73E-05	2.97E-05
1830		5.39E-05	4.75E-05	2.61E-05	2.82E-05
1860		5.09E-05	4.77E-05	2.73E-05	2.55E-05
1890		5.24E-05	4.72E-05	2.78E-05	2.48E-05
1920		5.07E-05	4.38E-05	2.51E-05	2.51E-05
1950		5.00E-05	4.46E-05	2.39E-05	2.65E-05
1980		5.08E-05	4.45E-05	2.31E-05	2.55E-05
2010		4.93E-05	4.47E-05	2.44E-05	2.86E-05
2040		4.83E-05	4.39E-05	2.41E-05	3.09E-05
2070		4.44E-05	4.35E-05	2.54E-05	3.43E-05
2100		4.44E-05	4.21E-05	2.27E-05	3.67E-05
2130		4.56E-05	4.07E-05	2.27E-05	3.80E-05
2160		4.74E-05	3.83E-05	2.27E-05	3.60E-05
2190		4.57E-05	3.86E-05	2.11E-05	3.66E-05
2220		4.46E-05	3.80E-05	2.11E-05	2.84E-05
2250		4.86E-05	3.67E-05	1.91E-05	2.60E-05
2280		4.95E-05	3.31E-05	1.87E-05	2.01E-05
2310		4.73E-05	3.47E-05	1.85E-05	1.68E-05
2340		4.75E-05	3.41E-05	1.80E-05	1.64E-05
2370		4.58E-05	3.54E-05	1.82E-05	1.68E-05
2400		4.55E-05	3.42E-05	1.80E-05	1.71E-05
2430		4.51E-05	3.41E-05	1.78E-05	1.70E-05
2460		4.49E-05	3.51E-05	1.71E-05	1.71E-05
2490		4.43E-05	3.54E-05	1.73E-05	1.64E-05
2520		4.32E-05	3.71E-05	1.73E-05	1.65E-05
2550		4.29E-05	3.42E-05	1.72E-05	1.79E-05
2580		4.27E-05	3.60E-05	1.72E-05	1.59E-05
2610		4.26E-05	3.57E-05	1.69E-05	1.46E-05
2640		4.25E-05	3.68E-05	1.69E-05	1.49E-05
2670		4.25E-05	3.61E-05	1.70E-05	1.52E-05
2700		4.06E-05	3.49E-05	1.70E-05	1.60E-05
2730		4.09E-05	3.58E-05	1.66E-05	1.56E-05
2760		4.13E-05	3.62E-05	1.68E-05	1.55E-05
2790		4.16E-05	3.68E-05	1.70E-05	1.55E-05
2820		4.21E-05	3.66E-05	1.70E-05	1.40E-05
2850		4.33E-05	3.43E-05	1.71E-05	1.48E-05
2880		4.31E-05	3.55E-05	1.68E-05	1.58E-05
2910		4.30E-05	3.52E-05	1.64E-05	1.57E-05
2940		4.27E-05	3.60E-05	1.64E-05	1.42E-05
2970		4.34E-05	3.56E-05	1.72E-05	1.41E-05
3000		4.40E-05	3.53E-05	1.68E-05	1.67E-05

**FLIGHT NO. C-413**  
**TOTAL VOLUME SCATTERING COEFFICIENT**

(JOB 2364 DATE 06/12/78)  
 DATE 72777 FLIGHT NO. C-413 GROUND LEVEL ALTITUDE (M)= 0

ALTITUDE (M)	TOTAL VOLUME SCATTERING COEFFICIENT (PER M)				
	FILTERS	2	4	3	5
3030		4.32E-05	3.49E-05	1.63E-05	1.55E-05
3060		4.33E-05	3.51E-05	1.62E-05	1.56E-05
3090		4.34E-05	3.69E-05	1.62E-05	1.42E-05
3120		4.31E-05	3.58E-05	1.62E-05	1.36E-05
3150		4.29E-05	3.71E-05	1.62E-05	1.48E-05
3180		4.40E-05	3.65E-05	1.61E-05	1.57E-05
3210		4.30E-05	3.73E-05	1.66E-05	1.55E-05
3240		4.32E-05	3.92E-05	1.63E-05	1.59E-05
3270		4.21E-05	3.67E-05	1.69E-05	1.63E-05
3300		4.29E-05	3.59E-05	1.60E-05	1.45E-05
3330		4.28E-05	3.73E-05	1.61E-05	1.67E-05
3360		4.28E-05	3.48E-05	1.61E-05	1.40E-05
3390		4.24E-05	3.47E-05	1.63E-05	1.55E-05
3420		4.21E-05	3.49E-05	1.61E-05	1.54E-05
3450		4.22E-05	3.49E-05	1.60E-05	1.54E-05
3480		4.14E-05	3.49E-05	1.58E-05	1.54E-05
3510		4.17E-05	3.64E-05	1.59E-05	1.55E-05
3540		4.16E-05	3.57E-05	1.59E-05	1.57E-05
3570		4.16E-05	3.53E-05	1.54E-05	1.72E-05
3600		4.11E-05	3.54E-05	1.52E-05	1.46E-05
3630		4.06E-05	3.42E-05	1.51E-05	1.39E-05
3660		4.07E-05	3.51E-05	1.54E-05	1.32E-05
3690		4.00E-05	3.47E-05	1.56E-05	1.56E-05
3720		3.85E-05	3.42E-05	1.53E-05	1.49E-05
3750		3.92E-05	3.51E-05	1.52E-05	1.47E-05
3780		3.86E-05	3.32E-05	1.57E-05	1.35E-05
3810		3.92E-05	3.47E-05	1.52E-05	1.53E-05
3840		3.92E-05	3.51E-05	1.54E-05	1.46E-05
3870		3.92E-05	3.55E-05	1.57E-05	1.40E-05
3900		3.87E-05	3.46E-05	1.60E-05	1.31E-05
3930		3.86E-05	3.41E-05	1.65E-05	1.42E-05
3960		3.85E-05	3.21E-05	1.64E-05	1.51E-05
3990		3.97E-05	3.43E-05	1.64E-05	1.50E-05
4020		3.85E-05	3.30E-05	1.50E-05	1.27E-05
4050		3.81E-05	3.24E-05	1.46E-05	1.53E-05
4080		3.82E-05	3.27E-05	1.45E-05	1.48E-05
4110		3.82E-05	3.31E-05	1.43E-05	1.44E-05
4140		3.84E-05	3.25E-05	1.18E-05	1.39E-05
4170		3.90E-05	3.26E-05	1.44E-05	1.38E-05
4200		3.77E-05	3.02E-05	1.45E-05	1.43E-05
4230		3.78E-05	3.11E-05	1.42E-05	1.30E-05
4260		3.79E-05	3.21E-05	1.40E-05	1.28E-05
4290		3.73E-05	3.10E-05	1.22E-05	1.38E-05
4320		3.81E-05	3.19E-05	1.18E-05	1.34E-05
4350		3.73E-05	3.19E-05	1.38E-05	1.30E-05
4380		3.73E-05	3.21E-05	1.32E-05	1.29E-05
4410		3.66E-05	3.23E-05	1.39E-05	1.19E-05
4440		3.58E-05	3.35E-05	1.36E-05	1.28E-05
4470		4.85E-05	3.13E-05	1.40E-05	1.26E-05
4500		1.59E-04	3.18E-05	1.47E-05	1.32E-05

## FLIGHT NO. C-413 TOTAL VOLUME SCATTERING COEFFICIENT

(JOB 2364 DATE 06/12/78) 1  
DATE 72777 FLIGHT NO. C-413 GROUND LEVEL ALTITUDE (M)= 0

ALTITUDE (M)	TOTAL VOLUME SCATTERING COEFFICIENT (PER M)				
	FILTERS	2	4	3	5
4530		2.69E-04	3.22E-05	1.46E-05	1.38E-05
4560		9.36E-05	3.21E-05	1.35E-05	1.28E-05
4590		6.26E-05	3.16E-05	1.33E-05	1.17E-05
4620		6.19E-05	3.13E-05	1.32E-05	1.23E-05
4650		3.88E-05	3.10E-05	1.31E-05	1.29E-05
4680		4.24E-05	3.07E-05	1.34E-05	1.14E-05
4710		2.80E-04	3.13E-05	1.37E-05	1.09E-05
4740		1.18E-04	3.07E-05	1.34E-05	1.14E-05
4770		7.73E-05	3.07E-05	1.34E-05	1.15E-05
4800		3.67E-05	3.01E-05	1.30E-05	1.00E-05
4830		3.44E-05	3.13E-05	1.33E-05	1.04E-05
4860		3.52E-05	3.13E-05	1.34E-05	1.35E-05
4890		3.59E-05	3.14E-05	1.36E-05	1.42E-05
4920		3.61E-05	3.06E-05	1.36E-05	1.16E-05
4950		3.60E-05	2.94E-05	1.29E-05	1.25E-05
4980		3.66E-05	2.89E-05	1.30E-05	1.42E-05
5010		3.61E-05	2.83E-05	1.31E-05	1.33E-05
5040		3.57E-05	2.76E-05	1.32E-05	1.31E-05
5070		3.52E-05	2.69E-05	1.33E-05	1.29E-05
5100		3.68E-05	2.80E-05	1.33E-05	1.23E-05
5130		3.57E-05	2.89E-05	1.32E-05	1.45E-05
5160		3.66E-05	3.28E-05	1.29E-05	1.40E-05
5190		3.65E-05	3.18E-05	1.29E-05	1.36E-05
5220		3.59E-05	3.08E-05	1.29E-05	2.19E-05
5250		3.59E-05	2.37E-05	1.27E-05	1.40E-04
5280		3.52E-05	2.95E-05	1.32E-05	3.87E-04
5310		3.48E-05	3.08E-05	1.28E-05	4.46E-04
5340		3.45E-05	3.10E-05	1.25E-05	4.79E-04
5370	(3.44E-05 )		9.18E-04	1.27E-05	5.40E-04
5400	(3.43E-05 )		2.89E-04	1.29E-05	6.60E-04
5430	(3.42E-05 )		1.43E-04	1.26E-05	5.52E-04
5460	(3.41E-05 )		9.84E-05	1.21E-05	6.39E-04
5490	(3.40E-05 )		5.39E-05	1.23E-05	7.71E-04
5520	(3.39E-05 )		5.82E-05	1.26E-05	9.03E-04
5550	(3.38E-05 )		1.54E-04	1.24E-05	1.93E-04
5580	(3.37E-05 )		1.19E-04	1.18E-05	4.61E-04
5610	(3.36E-05 )	(1.18E-04 )		1.18E-05	5.88E-04
5640	(3.34E-05 )	(1.18E-04 )		1.22E-05	5.14E-04
5670	(3.33E-05 )	(1.17E-04 )		1.16E-05	7.43E-04
5700	(3.32E-05 )	(1.17E-04 )	(1.16E-05 )		9.71E-04
FIRST DATA ALT	120	120	120	120	
LAST DATA ALT	5340	5580	5670	5700	

AD-A068 611

SCRIPPS INSTITUTION OF OCEANOGRAPHY LA JOLLA CA VISA--ETC F/6 20/6  
AIRBORNE MEASUREMENTS OF ATMOSPHERIC VOLUME SCATTERING COEFFICI--ETC(U)

JUN 78 S O DUNTLEY, R W JOHNSON, J I GORDON F19628-76-C-0004

UNCLASSIFIED

SIO-REF-78-28

AFOL-TR-78-0168

NL

2 OF 2

AD  
AD-011

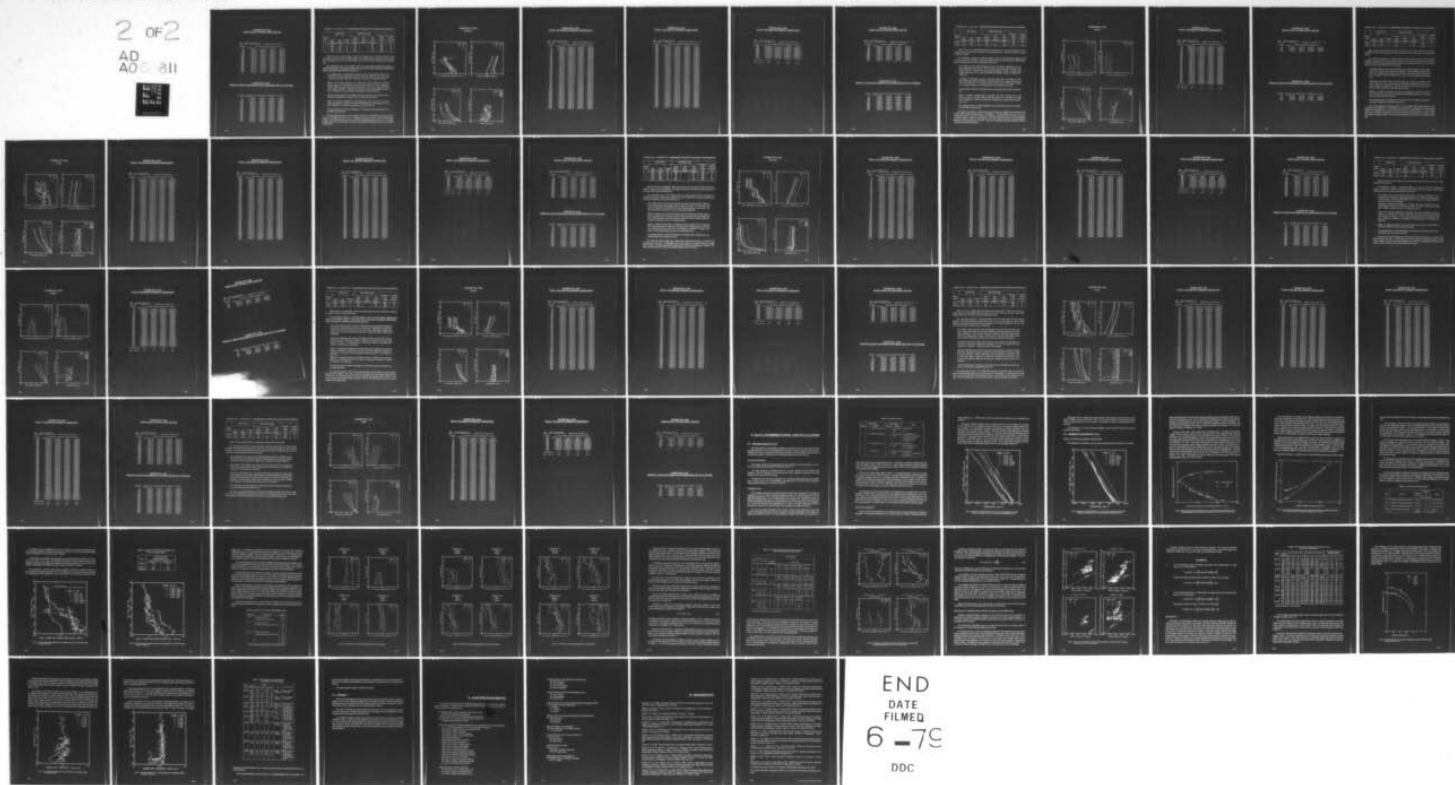

END  
DATE  
FILMED  
6-79  
DDC

## FLIGHT NO. C-413 EQUIVALENT ATTENUATION LENGTH

(JOB 2364 DATE 06/12/78)  
DATE 72777 FLIGHT NO. C-413 GROUND LEVEL ALTITUDE (M)= 0

ALTITUDE (M)	EQUIVALENT ATTENUATION LENGTH (M)			
	FILTERS	2	4	3
0	8.17E 03	9.16E 03	1.20E 04	1.72E 04
300	7.82E 03	9.19E 03	1.20E 04	1.61E 04
600	7.70E 03	9.32E 03	1.26E 04	1.49E 04
900	7.82E 03	9.53E 03	1.22E 04	1.50E 04
1200	8.08E 03	9.87E 03	1.26E 04	1.48E 04
1500	8.47E 03	1.07E 04	1.34E 04	1.55E 04
1800	9.05E 03	1.16E 04	1.46E 04	1.67E 04
2100	9.81E 03	1.25E 04	1.60E 04	1.81E 04
2400	1.05E 04	1.34E 04	1.75E 04	1.94E 04
2700	1.12E 04	1.42E 04	1.90E 04	2.10E 04
3000	1.18E 04	1.50E 04	2.04E 04	2.25E 04
3300	1.24E 04	1.56E 04	2.17E 04	2.39E 04
3600	1.29E 04	1.62E 04	2.30E 04	2.52E 04
3900	1.34E 04	1.68E 04	2.42E 04	2.65E 04
4200	1.39E 04	1.73E 04	2.53E 04	2.78E 04
4500	1.42E 04	1.79E 04	2.65E 04	2.90E 04
4800	1.37E 04	1.84E 04	2.76E 04	3.02E 04
5100	1.41E 04	1.89E 04	2.86E 04	3.14E 04
5400	1.45E 04	1.74E 04	2.97E 04	2.31E 04
5700	1.49E 04	1.65E 04	3.07E 04	1.36E 04

## FLIGHT NO. C-413 VERTICAL BEAM TRANSMITTANCE FROM GROUND TO ALTITUDE

ALTITUDE (M)	VERTICAL BEAM TRANSMITTANCE FROM GROUND TO ALTITUDE			
	FILTERS	2	4	3
0	1.00E 00	1.00E 00	1.00E 00	1.00E 00
300	9.62E-01	9.68E-01	9.75E-01	9.82E-01
600	9.25E-01	9.38E-01	9.54E-01	9.60E-01
900	8.91E-01	9.10E-01	9.29E-01	9.42E-01
1200	8.62E-01	8.85E-01	9.09E-01	9.22E-01
1500	8.38E-01	8.69E-01	8.94E-01	9.08E-01
1800	8.20E-01	8.57E-01	8.84E-01	8.98E-01
2100	8.07E-01	8.45E-01	8.77E-01	8.90E-01
2400	7.96E-01	8.36E-01	8.72E-01	8.83E-01
2700	7.86E-01	8.27E-01	8.68E-01	8.79E-01
3000	7.76E-01	8.18E-01	8.63E-01	8.75E-01
3300	7.66E-01	8.09E-01	8.59E-01	8.71E-01
3600	7.56E-01	8.01E-01	8.55E-01	8.67E-01
3900	7.47E-01	7.93E-01	8.51E-01	8.63E-01
4200	7.39E-01	7.85E-01	8.47E-01	8.60E-01
4500	7.29E-01	7.77E-01	8.44E-01	8.55E-01
4800	7.04E-01	7.70E-01	8.40E-01	8.53E-01
5100	6.97E-01	7.63E-01	8.37E-01	8.50E-01
5400	6.90E-01	7.34E-01	8.34E-01	7.91E-01
5700	6.83E-01	7.08E-01	8.31E-01	6.57E-01

FLIGHT C-414 - 28 JULY 1977 - DESCRIPTION OF FLIGHT & WEATHER CHARACTERISTICS

Filter Ident	Data Interval			Solar Zenith Angle			Maximum Flight Altitude (m)	Average Terrain Elevation (m)
	Start (GMT)	End (GMT)	Elapsed (hrs)	Initial ST&LV (degrees)	Solar Transit (degrees)	Final V-PRO (degrees)		
2	0939	1110	1.5	40.7	-	34.3	3000	18
3	0940	1059	1.3	40.5	-	34.6	3030	18
4	0942	1032	0.8	40.4	-	36.0	3000	18
5	0943	1136	1.9	40.2	-	33.9	3030	18

Flight C-414 was a morning flight. There were multiple layers of scattered to broken clouds resulting in a general overcast at all flight altitudes. The in-flight pictures indicate few patches of blue sky. The flight was run over the alternate Ahlhorn track due to inclement weather along the Meppen track.

The approximate east to west Ahlhorn track was located between Lathen and Ahlhorn in northwestern Germany. Typical terrain features were heavily cultivated low lying flat farmlands interspersed with occasional dark woods and small towns.

The in-flight observer reported broken cumulus clouds with bases 300-360 meters (1000 to 1200 feet) with tops of the largest cumulus 1350 meters (4500 feet), most of the tops were below 1200 meters (4000 feet). Heavy haze was present with imbedded cumulus.

Meppen, 40 kilometers southwest of the flight center point, reported two layers of cumulus clouds. The lower scattered layer had bases varying from 300 to 600 meters (1000 to 2000 feet) and the higher layer was broken with 6/8 to 7/8 coverage at 900-1200 meters (3000 to 4000 feet). Visibility of 3.2 kilometers in light fog gradually improved to 4.0 to 7.0 kilometers in haze and then to 9.0 kilometers with no obstructions.

Locations farther southwest of the flight center point reported a layer of altocumulus at 3000 meters (10,000 feet) and broken cirrus at 7500 meters (25,000 feet).

Eelde, 89 kilometers westnorthwest of the flight track center, observed two levels of cumulus contributing to ceilings of 900 meters (3000 feet) and 7/8 altocumulus at 2100 meters (7000 feet). Visibility was reported as 12.0 to 15.0 kilometers.

The radiosonde station at Rheine/Waldhugel was 73 kilometers south and upstream from the flight track center point.

The surface chart depicted no fronts in Europe. There was a 1012 millibar closed low in eastern France and the flight track was in a col. A trough east of the track was on a line from Hamburg to Stuttgart. At 500 millibars there was a low at 62°N 9°E and another near Brest, France. Over northern Germany between the two lows there was light southsoutheasterly flow and the air mass was unstable maritime polar.

**FLIGHT NO. C-414**  
**AHLHORN**

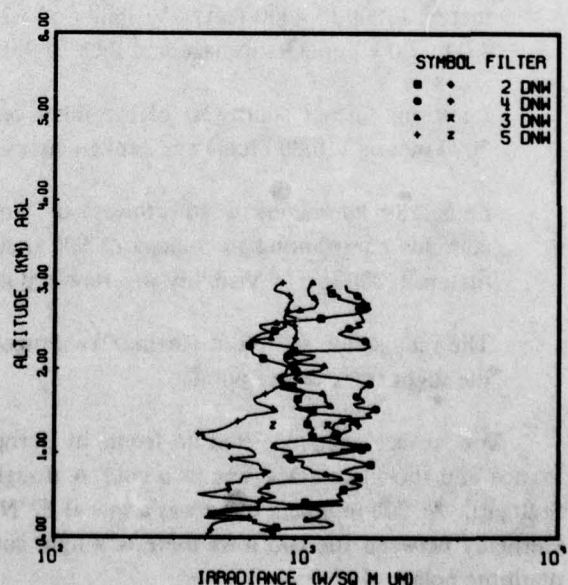
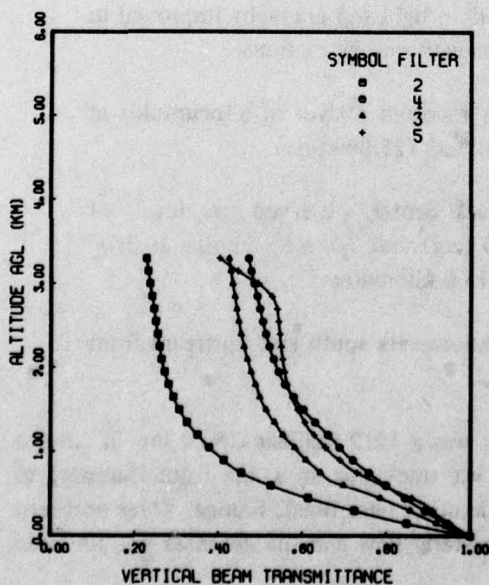
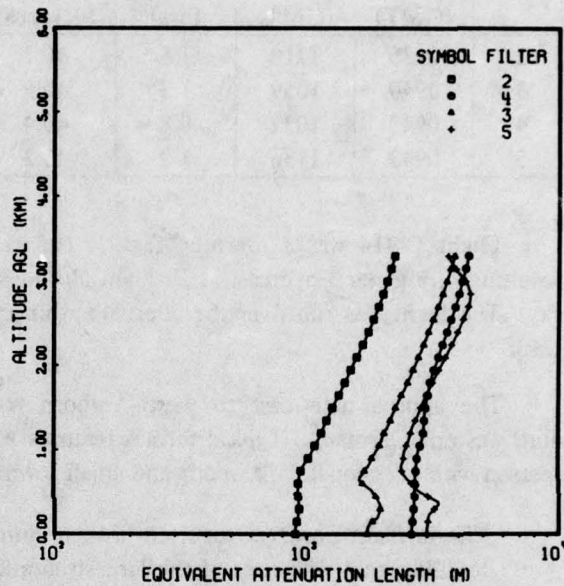
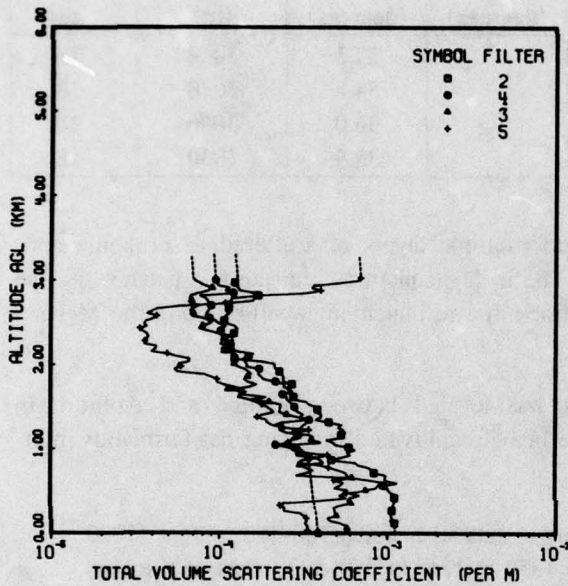

## FLIGHT NO. C-414 TOTAL VOLUME SCATTERING COEFFICIENT

(JOB 9435 DATE 06/15/78)  
DATE 72877 FLIGHT NO. C-414 GROUND LEVEL ALTITUDE (M)= 18

ALTITUDE (M)	TOTAL VOLUME SCATTERING COEFFICIENT (PER M)			
	FILTERS	2	4	3
0	(1.11E-03)	3.87E-04	(5.79E-04)	(3.37E-04)
30	(1.11E-03)	(3.86E-04)	(5.77E-04)	3.35E-04
60	(1.11E-03)	(3.84E-04)	5.75E-04	3.35E-04
90	(1.10E-03)	(3.83E-04)	5.63E-04	3.34E-04
120	1.10E-03	(3.81E-04)	5.27E-04	3.23E-04
150	1.03E-03	(3.80E-04)	4.55E-04	3.34E-04
180	1.07E-03	(3.78E-04)	4.41E-04	3.29E-04
210	1.04E-03	(3.77E-04)	4.97E-04	3.17E-04
240	1.05E-03	(3.75E-04)	4.88E-04	3.02E-04
270	1.06E-03	(3.74E-04)	4.85E-04	2.40E-04
300	1.07E-03	(3.72E-04)	4.77E-04	2.47E-04
330	1.04E-03	(3.71E-04)	5.22E-04	2.31E-04
360	1.10E-03	(3.70E-04)	6.11E-04	2.44E-04
390	1.10E-03	(3.68E-04)	5.84E-04	4.09E-04
420	1.12E-03	(3.67E-04)	6.10E-04	5.74E-04
450	1.16E-03	(3.65E-04)	6.89E-04	5.25E-04
480	1.06E-03	(3.64E-04)	5.94E-04	5.79E-04
510	1.02E-03	(3.62E-04)	7.49E-04	5.83E-04
540	1.01E-03	(3.61E-04)	8.67E-04	4.90E-04
570	9.56E-04	(3.59E-04)	8.90E-04	5.32E-04
600	1.15E-03	(3.58E-04)	9.86E-04	5.51E-04
630	9.76E-04	(3.56E-04)	8.14E-04	4.88E-04
660	9.79E-04	(3.55E-04)	6.20E-04	5.97E-04
690	9.89E-04	(3.54E-04)	2.90E-04	5.83E-04
720	8.40E-04	(3.52E-04)	3.33E-04	5.68E-04
750	8.14E-04	(3.51E-04)	3.66E-04	5.16E-04
780	7.85E-04	(3.49E-04)	3.33E-04	4.52E-04
810	6.75E-04	(3.48E-04)	3.03E-04	4.01E-04
840	6.47E-04	(3.46E-04)	4.21E-04	3.00E-04
870	4.69E-04	(3.45E-04)	4.01E-04	3.17E-04
900	5.37E-04	(3.43E-04)	3.81E-04	3.81E-04
930	6.06E-04	3.42E-04	2.91E-04	4.46E-04
960	5.79E-04	3.10E-04	2.99E-04	3.28E-04
990	6.47E-04	2.77E-04	3.16E-04	3.04E-04
1020	5.96E-04	2.68E-04	2.62E-04	3.04E-04
1050	4.98E-04	2.18E-04	2.44E-04	2.75E-04
1080	4.79E-04	2.62E-04	4.06E-04	2.59E-04
1110	4.38E-04	2.72E-04	3.56E-04	2.70E-04
1140	5.44E-04	3.09E-04	3.67E-04	2.79E-04
1170	5.38E-04	2.87E-04	3.47E-04	3.17E-04
1200	5.69E-04	2.89E-04	2.53E-04	2.72E-04
1230	5.48E-04	3.01E-04	2.31E-04	3.44E-04
1260	5.13E-04	3.10E-04	2.39E-04	2.43E-04
1290	5.42E-04	3.22E-04	2.17E-04	2.07E-04
1320	4.52E-04	3.37E-04	2.39E-04	1.95E-04
1350	3.77E-04	3.46E-04	3.30E-04	1.92E-04
1380	4.08E-04	3.03E-04	2.99E-04	1.70E-04
1410	4.07E-04	3.20E-04	2.53E-04	1.81E-04
1440	3.79E-04	2.99E-04	2.29E-04	2.13E-04
1470	3.87E-04	2.82E-04	2.31E-04	2.04E-04
1500	3.77E-04	2.82E-04	2.32E-04	1.94E-04

**FLIGHT NO. C-414**  
**TOTAL VOLUME SCATTERING COEFFICIENT**

(JOB 9435 DATE 06/15/78)  
 DATE 72877 FLIGHT NO. C-414 GROUND LEVEL ALTITUDE (M)= 18

ALTITUDE (M)	TOTAL VOLUME SCATTERING COEFFICIENT (PER M)				
	FILTERS	2	4	3	5
1530		3.45E-04	2.73E-04	2.34E-04	1.81E-04
1560		3.31E-04	2.67E-04	2.00E-04	1.67E-04
1590		2.79E-04	2.53E-04	1.56E-04	1.53E-04
1620		2.79E-04	2.54E-04	1.90E-04	1.29E-04
1650		2.65E-04	2.39E-04	1.36E-04	1.33E-04
1680		2.75E-04	2.66E-04	1.39E-04	1.40E-04
1710		2.58E-04	2.67E-04	1.13E-04	1.38E-04
1740		2.61E-04	2.42E-04	1.51E-04	1.23E-04
1770		2.72E-04	2.48E-04	1.68E-04	1.05E-04
1800		2.41E-04	2.17E-04	1.48E-04	9.73E-05
1830		2.43E-04	1.85E-04	1.41E-04	9.74E-05
1860		2.42E-04	1.78E-04	1.48E-04	8.95E-05
1890		2.36E-04	1.71E-04	1.56E-04	8.15E-05
1920		2.29E-04	1.74E-04	1.49E-04	5.67E-05
1950		2.17E-04	1.74E-04	1.43E-04	5.45E-05
1980		2.15E-04	1.45E-04	1.30E-04	5.93E-05
2010		2.14E-04	1.47E-04	1.23E-04	5.74E-05
2040		1.80E-04	1.43E-04	1.23E-04	6.67E-05
2070		1.24E-04	1.39E-04	1.19E-04	6.73E-05
2100		1.21E-04	1.50E-04	1.25E-04	5.70E-05
2130		1.26E-04	1.60E-04	1.24E-04	4.93E-05
2160		1.19E-04	1.28E-04	1.07E-04	3.94E-05
2190		1.13E-04	1.17E-04	1.04E-04	4.19E-05
2220		1.17E-04	1.12E-04	1.11E-04	4.24E-05
2250		1.13E-04	1.13E-04	1.02E-04	3.59E-05
2280		1.22E-04	1.10E-04	1.04E-04	3.62E-05
2310		1.19E-04	1.07E-04	1.07E-04	3.72E-05
2340		1.21E-04	1.04E-04	1.18E-04	3.81E-05
2370		1.23E-04	1.02E-04	9.90E-05	3.74E-05
2400		1.24E-04	1.02E-04	8.75E-05	3.51E-05
2430		1.29E-04	1.03E-04	7.59E-05	3.39E-05
2460		1.24E-04	1.10E-04	8.00E-05	3.72E-05
2490		1.11E-04	9.95E-05	8.89E-05	3.56E-05
2520		1.07E-04	9.54E-05	9.13E-05	3.67E-05
2550		1.10E-04	8.80E-05	8.15E-05	4.08E-05
2580		1.09E-04	8.30E-05	6.88E-05	4.26E-05
2610		1.16E-04	8.47E-05	7.03E-05	3.72E-05
2640		1.09E-04	8.65E-05	6.71E-05	4.01E-05
2670		1.14E-04	8.82E-05	6.93E-05	4.30E-05
2700		1.19E-04	8.99E-05	7.53E-05	5.92E-05
2730		1.08E-04	8.73E-05	6.79E-05	1.09E-04
2760		1.19E-04	8.57E-05	6.86E-05	1.59E-04
2790		1.19E-04	8.29E-05	6.69E-05	1.64E-04
2820		1.71E-04	7.71E-05	6.78E-05	1.60E-04
2850		1.67E-04	1.22E-04	7.55E-05	3.20E-04
2880		1.33E-04	1.09E-04	8.70E-05	4.03E-04
2910		1.30E-04	1.15E-04	9.13E-05	3.56E-04
2940		1.27E-04	9.89E-05	8.21E-05	3.69E-04
2970		1.24E-04	9.73E-05	7.70E-05	5.04E-04
3000		1.29E-04	9.56E-05	7.18E-05	6.74E-04

**FLIGHT NO. C-414**  
**TOTAL VOLUME SCATTERING COEFFICIENT**

(JOB 9435 DATE 06/15/78)  
 DATE 72877 FLIGHT NO. C-414 GROUND LEVEL ALTITUDE (M)= 18

ALTITUDE (M)	TOTAL VOLUME SCATTERING COEFFICIENT (PER M)				
	FILTERS	2	4	3	5
3030	(1.28E-04 )	(9.53E-05 )	7.01E-05	6.96E-04	
3060	(1.28E-04 )	(9.50E-05 )	(6.98E-05 )	(6.94E-04 )	
3090	(1.28E-04 )	(9.47E-05 )	(6.96E-05 )	(6.92E-04 )	
3120	(1.27E-04 )	(9.44E-05 )	(6.94E-05 )	(6.90E-04 )	
3150	(1.27E-04 )	(9.41E-05 )	(6.92E-05 )	(6.88E-04 )	
3180	(1.26E-04 )	(9.38E-05 )	(6.90E-05 )	(6.85E-04 )	
3210	(1.26E-04 )	(9.35E-05 )	(6.88E-05 )	(6.83E-04 )	
3240	(1.26E-04 )	(9.32E-05 )	(6.85E-05 )	(6.81E-04 )	
3270	(1.25E-04 )	(9.30E-05 )	(6.83E-05 )	(6.79E-04 )	
3300	(1.25E-04 )	(9.27E-05 )	(6.81E-05 )	(6.77E-04 )	
FIRST DATA ALT	120	0	60	30	
LAST DATA ALT	3000	3000	3030	3030	

**FLIGHT NO. C-414**  
**EQUIVALENT ATTENUATION LENGTH**

(JOB 9435 DATE 06/15/78)  
DATE 72877 FLIGHT NO. C-414 GROUND LEVEL ALTITUDE (M)= 18

ALTITUDE (M)	EQUIVALENT ATTENUATION LENGTH (M)				
	FILTERS	2	4	3	5
0		8.98E 02	2.58E 03	1.73E 03	2.97E 03
300		9.29E 02	2.63E 03	1.95E 03	3.18E 03
600		9.30E 02	2.68E 03	1.67E 03	2.60E 03
900		1.02E 03	2.74E 03	1.81E 03	2.42E 03
1200		1.14E 03	2.90E 03	2.02E 03	2.58E 03
1500		1.27E 03	2.95E 03	2.25E 03	2.83E 03
1800		1.42E 03	3.08E 03	2.51E 03	3.14E 03
2100		1.58E 03	3.31E 03	2.77E 03	3.53E 03
2400		1.75E 03	3.59E 03	3.03E 03	3.96E 03
2700		1.92E 03	3.87E 03	3.31E 03	4.37E 03
3000		2.08E 03	4.13E 03	3.58E 03	4.25E 03
3300		2.23E 03	4.38E 03	3.84E 03	3.62E 03

**FLIGHT NO. C-414**  
**VERTICAL BEAM TRANSMITTANCE FROM GROUND TO ALTITUDE**

ALTITUDE (M)	VERTICAL BEAM TRANSMITTANCE FROM GROUND TO ALTITUDE				
	FILTERS	2	4	3	5
0		1.00E 00	1.00E 00	1.00E 00	1.00E 00
300		7.24E-01	8.92E-01	8.57E-01	9.10E-01
600		5.25E-01	8.00E-01	6.98E-01	7.94E-01
900		4.12E-01	7.20E-01	6.09E-01	6.89E-01
1200		3.50E-01	6.61E-01	5.53E-01	6.28E-01
1500		3.06E-01	6.02E-01	5.13E-01	5.88E-01
1800		2.81E-01	5.57E-01	4.88E-01	5.64E-01
2100		2.64E-01	5.31E-01	4.68E-01	5.52E-01
2400		2.54E-01	5.12E-01	4.53E-01	5.45E-01
2700		2.46E-01	4.98E-01	4.43E-01	5.39E-01
3000		2.36E-01	4.84E-01	4.33E-01	4.94E-01
3300		2.27E-01	4.70E-01	4.24E-01	4.02E-01

FLIGHT C-415 - 29 JULY 1977 - DESCRIPTION OF FLIGHT & WEATHER CHARACTERISTICS

Filter Ident	Data Interval			Solar Zenith Angle			Maximum Flight Altitude (m)	Average Terrain Elevation (m)
	Start (GMT)	End (GMT)	Elapsed (hrs)	Initial ST&LV (degrees)	Solar Transit (degrees)	Final V-PRO (degrees)		
4 & 5	1027	1123	0.9	36.8	-	34.4	870	18
2 & 3	1126	1207	0.7	34.4	34.3	34.9	870	18

Flight C-415 was a midday flight spanning local apparent noon. There were multiple layers of clouds varying from scattered at low levels to overcast high clouds. The general effect was overcast throughout the flight.

The approximate northeast to southwest Meppen track was located between Oldenburg and Lathen in northwestern Germany. Typical terrain features were heavily cultivated low lying flat farmlands interspersed with occasional dark woods and small towns.

The in-flight observer reported altostratus clouds at 1950 meters (6500 feet) with very light precipitation under the deck. There were also scattered cumulus with bases at 600 meters (2000 feet). Moderate haze was observed throughout the flight. The slant range visibility varied from 5 to 15 miles at 300 meters (1000 feet) as well as at 1000 meters (3000 feet).

At Meppen, 39 kilometers southwest of the flight center point, 1/8 cumulus at 1500 meters (5000 feet) gradually increased to 5/8 coverage with some scattered lower bases at 750 meters (2500 feet). Altocumulus covered 7/8 of the sky at 3000 meters (10,000 feet). Visibility varied from 7.0 to 9.0 kilometers with some light rain reported.

Locations farther southwest of the flight center point reported similar conditions with light rain.

Eelde, 71 kilometers westnorthwest of the flight track center, observed 2/8 to 3/8 cumulus at 600 to 750 meters (2000 to 2500 feet) and 6/8 to 7/8 altostratus at 3000 meters (10,000 feet). Visibility was reported as 30 kilometers and there were no observations of rain.

The radiosonde station at Rheine/Waldhugel was 82 kilometers south and downstream from the flight track center point.

The surface chart showed a trough through central Germany to the Balearics and a ridge from the Atlantic High extended through Britain to Scandinavia. The 500 millibar chart had a low over southwestern France. There was a ridge from the Azores to Scotland and another from the Adriatic to the tip of Sweden. Another low was centered at 53°N 30°E. The track was in a col of weak pressure gradients in the midst of these four systems. There was northeasterly flow below 4500 meters and the air mass was stable maritime polar.

# FLIGHT NO. C-415

## MEPPEN

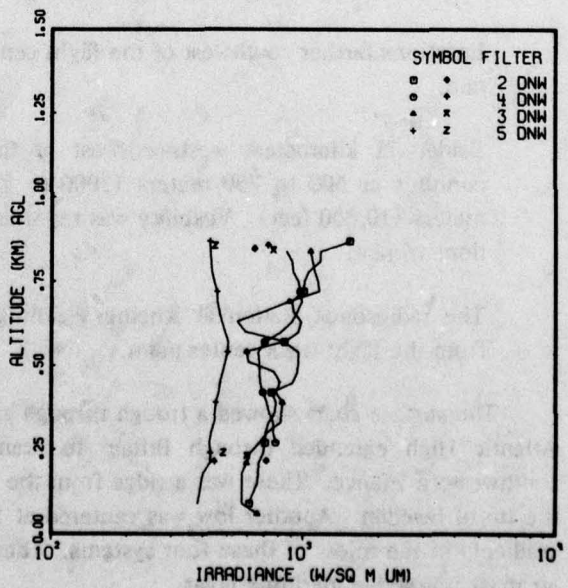
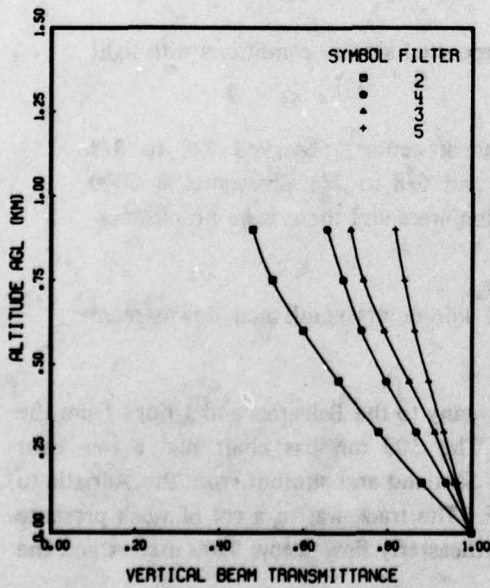
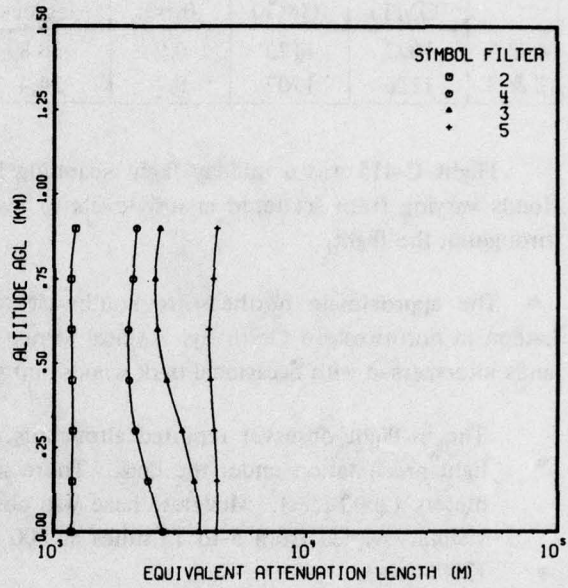
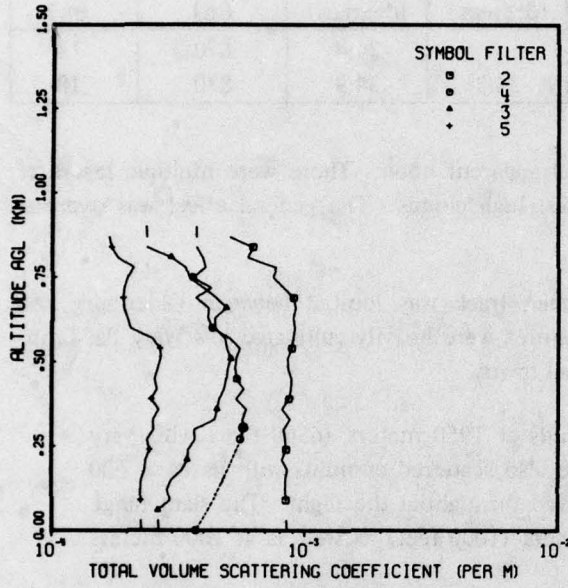

**FLIGHT NO. C-415**  
**TOTAL VOLUME SCATTERING COEFFICIENT**

(JOB 9454 DATE 06/15/78)  
 DATE 72977 FLIGHT NO. C-415 GROUND LEVEL ALTITUDE (M)= 18

ALTITUDE (M)	TOTAL VOLUME SCATTERING COEFFICIENT (PER M)			
	FILTERS	2	4	3
0	(8.51E-04 )	3.71E-04	(2.65E-04 )	(2.26E-04 )
30	(8.47E-04 )	(3.92E-04 )	(2.64E-04 )	(2.25E-04 )
60	(8.45E-04 )	(4.13E-04 )	2.63E-04	(2.25E-04 )
90	8.42E-04	(4.34E-04 )	2.94E-04	2.24E-04
120	8.43E-04	(4.55E-04 )	2.87E-04	2.25E-04
150	8.43E-04	(4.76E-04 )	2.97E-04	2.26E-04
180	8.58E-04	(4.97E-04 )	3.28E-04	2.33E-04
210	8.16E-04	(5.18E-04 )	3.45E-04	2.36E-04
240	8.48E-04	(5.39E-04 )	3.48E-04	2.45E-04
270	8.39E-04	5.60E-04	3.69E-04	2.39E-04
300	8.27E-04	5.72E-04	3.66E-04	2.53E-04
330	8.75E-04	5.69E-04	4.42E-04	2.52E-04
360	8.16E-04	5.88E-04	4.51E-04	2.65E-04
390	8.66E-04	5.36E-04	4.60E-04	2.48E-04
420	8.80E-04	5.74E-04	4.80E-04	2.61E-04
450	8.82E-04	5.38E-04	4.90E-04	2.55E-04
480	8.56E-04	5.29E-04	4.95E-04	2.62E-04
510	8.52E-04	5.33E-04	5.08E-04	2.69E-04
540	8.84E-04	5.52E-04	4.90E-04	2.66E-04
570	8.98E-04	5.03E-04	4.81E-04	2.49E-04
600	9.10E-04	4.29E-04	4.41E-04	2.03E-04
630	8.97E-04	4.12E-04	4.38E-04	1.97E-04
660	9.16E-04	4.14E-04	4.87E-04	1.92E-04
690	8.96E-04	3.69E-04	4.43E-04	1.90E-04
720	8.19E-04	4.23E-04	3.93E-04	1.92E-04
750	7.46E-04	3.58E-04	3.47E-04	1.98E-04
780	7.69E-04	4.04E-04	3.37E-04	2.10E-04
810	5.94E-04	3.94E-04	2.95E-04	1.81E-04
840	6.23E-04	3.73E-04	2.37E-04	1.72E-04
870	5.04E-04	(3.72E-04 )	(2.36E-04 )	1.68E-04
900	(5.03E-04 )	(3.71E-04 )	(2.36E-04 )	(1.67E-04 )

FIRST DATA ALT      90                      0                      60                      90  
 LAST DATA ALT      870                      840                      840                      870

**FLIGHT NO. C-415  
EQUIVALENT ATTENUATION LENGTH**

(JOB 9454 DATE 06/15/78)  
DATE 72977 FLIGHT NO. C-415 GROUND LEVEL ALTITUDE (M)= 18

ALTITUDE (M)	FILTERS	EQUIVALENT ATTENUATION LENGTH (M)			
		2	4	3	5
0		1.18E 03	2.70E 03	3.78E 03	4.42E 03
300		1.19E 03	2.10E 03	3.22E 03	4.31E 03
600		1.17E 03	1.96E 03	2.56E 03	4.10E 03
900		1.22E 03	2.13E 03	2.64E 03	4.44E 03

**FLIGHT NO. C-415  
VERTICAL BEAM TRANSMITTANCE FROM GROUND TO ALTITUDE**

ALTITUDE (M)	FILTERS	VERTICAL BEAM TRANSMITTANCE FROM GROUND TO ALTITUDE			
		2	4	3	5
0		1.00E 00	1.00E 00	1.00E 00	1.00E 00
300		7.77E-01	8.67E-01	9.11E-01	9.33E-01
600		5.99E-01	7.37E-01	7.91E-01	8.64E-01
900		4.79E-01	6.55E-01	7.1E-01	8.16E-01

FLIGHT C-416 - 1 AUGUST 1977 - DESCRIPTION OF FLIGHT & WEATHER CHARACTERISTICS

Filter Ident	Data Interval			Solar Zenith Angle			Maximum Flight Altitude (m)	Average Terrain Elevation (m)
	Start (GMT)	End (GMT)	Elapsed (hrs)	Initial ST&LV (degrees)	Solar Transit (degrees)	Final V-PRO (degrees)		
2 & 3	1124	1312	1.8	36.7	36.7	42.4	4590	0
4 & 5	1319	1450	1.5	43.0	-	53.9	4620	0

Flight C-416 was an afternoon flight, after local apparent noon. There were partly cloudy skies throughout the flight with scattered low altitude cumulus and scattered cirrus above the highest flight altitude.

The approximate southeast to northwest Rodby track was located south of Lolland Island, Denmark. Typical terrain features along the nearby coast to the north of the track were flat cultivated farmlands interspersed with occasional woods and small towns. Directly beneath the track and to the south were the relatively shallow waters of Femer Bay.

The in-flight observer noted cumulus building up over the land and blowing off with bases 510 meters (1700 feet) tops 1560 meters (5200 feet) and thin scattered to broken cirrus. There were multiple layers of light to moderate haze. The slant visibility varied from a low of 15 miles at 1500 meters (5000 feet) to a high of 30 miles at 3000 meters (10,000 feet).

Fehmarnbelt, 9 kilometers south of the track center point, reported 1/8 cumulus at 450 meters (1500 feet), 2/8 to 3/8 altostratus at 3600 meters (12,000 feet) and 3/8 to 6/8 cirrus at 6000 meters (20,000 feet). The layer of broken cirrus was thin and did not constitute a ceiling. Visibility was reported as 20.0 kilometers.

Kegnaes, 76 kilometers westnorthwest of the track center point, reported clear skies in early morning with 2/8 to 4/8 cirrus at 6000 meters (20,000 feet) after noon. Visibility was recorded as 15.0 to 20.0 kilometers.

The radiosonde station at Schleswig was 103 kilometers west of the flight track center and located in an airflow that was parallel with the track.

The surface chart showed a dissipating cold front that extended through central Yugoslavia, north central Italy, then northwest into central Belgium and the North Sea. Ridging from the Atlantic High reached into Scandanavia with a closed 1025 millibar high in southwestern Britain. At 500 millibars there was a low system in southeastern Germany that extended over the flight track. In addition, there was a ridge from Spain to Britain. The flow was northeasterly and the air mass was unstable maritime polar.

# FLIGHT NO. C-416

RODBY

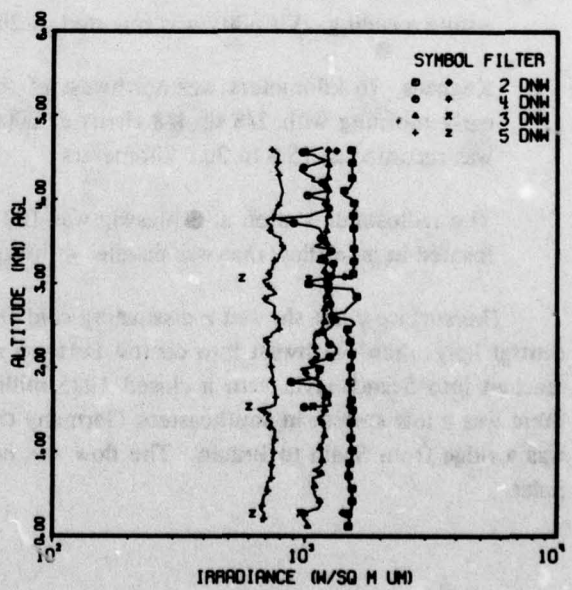
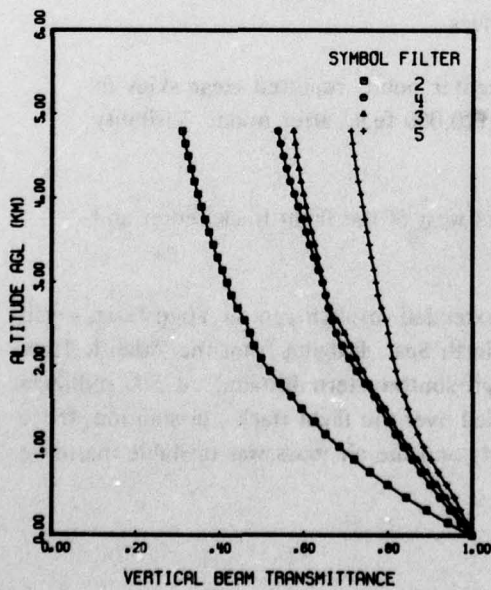
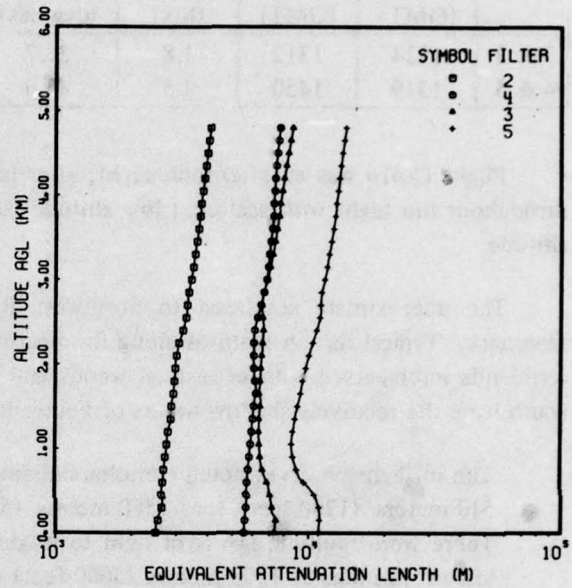
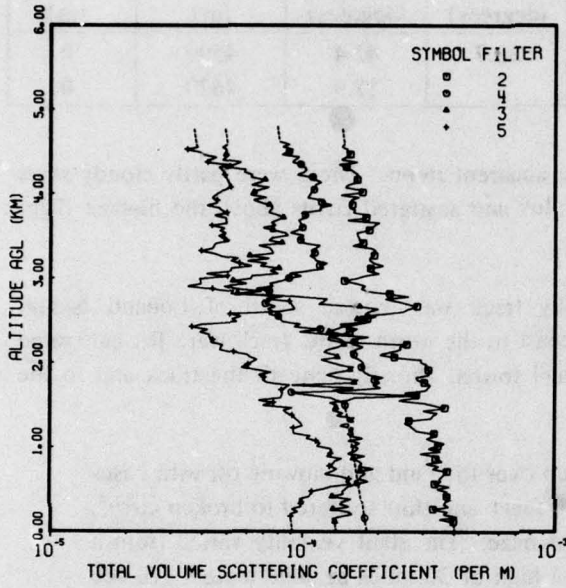

**FLIGHT NO. C-416**  
**TOTAL VOLUME SCATTERING COEFFICIENT**

(JOB 9471 DATE 06/15/78)  
 DATE 80177 FLIGHT NO. C-416 GROUND LEVEL ALTITUDE (M)= 0

ALTITUDE (M)	TOTAL VOLUME SCATTERING COEFFICIENT (PER M)			
	FILTERS	2	4	3
0	(4.02E-04)	(1.80E-04)	(1.36E-04)	(9.14E-05)
30	(4.00E-04)	(1.79E-04)	(1.36E-04)	(9.09E-05)
60	(3.99E-04)	(1.79E-04)	(1.35E-04)	(9.07E-05)
90	(3.98E-04)	(1.78E-04)	(1.35E-04)	(9.05E-05)
120	3.97E-04	(1.77E-04)	1.35E-04	(9.03E-05)
150	3.49E-04	(1.77E-04)	1.32E-04	(9.00E-05)
180	4.09E-04	(1.76E-04)	1.40E-04	8.98E-05
210	3.63E-04	(1.76E-04)	1.57E-04	8.98E-05
240	3.75E-04	(1.75E-04)	1.51E-04	9.60E-05
270	3.28E-04	1.74E-04	1.32E-04	9.07E-05
300	3.79E-04	(1.74E-04)	1.53E-04	9.87E-05
330	3.63E-04	(1.73E-04)	1.40E-04	9.83E-05
360	3.69E-04	(1.72E-04)	1.45E-04	1.02E-04
390	3.88E-04	(1.72E-04)	1.57E-04	9.84E-05
420	3.76E-04	(1.71E-04)	1.33E-04	1.07E-04
450	3.65E-04	(1.70E-04)	1.47E-04	1.09E-04
480	3.80E-04	(1.70E-04)	1.45E-04	1.10E-04
510	3.46E-04	(1.69E-04)	1.49E-04	1.22E-04
540	3.86E-04	(1.69E-04)	1.53E-04	1.31E-04
570	3.37E-04	(1.68E-04)	1.66E-04	1.57E-04
600	3.58E-04	(1.67E-04)	1.84E-04	1.50E-04
630	3.52E-04	(1.67E-04)	1.70E-04	1.54E-04
660	3.61E-04	(1.66E-04)	1.72E-04	1.43E-04
690	3.70E-04	(1.65E-04)	1.79E-04	1.24E-04
720	3.77E-04	(1.65E-04)	1.71E-04	1.33E-04
750	3.31E-04	(1.64E-04)	1.93E-04	1.38E-04
780	3.50E-04	(1.63E-04)	1.69E-04	1.29E-04
810	3.13E-04	(1.63E-04)	1.74E-04	1.33E-04
840	3.60E-04	(1.62E-04)	1.68E-04	1.36E-04
870	3.33E-04	(1.62E-04)	1.60E-04	1.44E-04
900	3.45E-04	(1.61E-04)	1.78E-04	1.25E-04
930	2.96E-04	(1.60E-04)	1.52E-04	1.30E-04
960	3.54E-04	(1.60E-04)	1.63E-04	1.32E-04
990	3.19E-04	(1.59E-04)	1.68E-04	1.30E-04
1020	3.47E-04	(1.58E-04)	1.60E-04	1.15E-04
1050	3.70E-04	(1.58E-04)	1.70E-04	1.18E-04
1080	3.33E-04	(1.57E-04)	1.53E-04	1.14E-04
1110	3.13E-04	(1.56E-04)	1.75E-04	1.04E-04
1140	3.39E-04	(1.56E-04)	1.55E-04	1.08E-04
1170	3.34E-04	(1.55E-04)	1.56E-04	9.27E-05
1200	2.85E-04	(1.54E-04)	1.58E-04	9.25E-05
1230	2.76E-04	(1.54E-04)	1.60E-04	9.25E-05
1260	2.88E-04	(1.53E-04)	1.42E-04	1.01E-04
1290	2.55E-04	(1.53E-04)	1.52E-04	9.87E-05
1320	2.66E-04	(1.52E-04)	1.57E-04	9.62E-05
1350	3.25E-04	(1.51E-04)	1.61E-04	9.37E-05
1380	3.31E-04	(1.51E-04)	1.38E-04	9.13E-05
1410	3.44E-04	(1.50E-04)	1.45E-04	8.69E-05
1440	3.02E-04	(1.49E-04)	1.33E-04	8.45E-05
1470	3.68E-04	(1.49E-04)	1.36E-04	9.15E-05
1500	3.34E-04	(1.48E-04)	1.38E-04	7.00E-05

**FLIGHT NO. C-416**  
**TOTAL VOLUME SCATTERING COEFFICIENT**

(JOB 9471 DATE 06/15/78)  
 DATE 80177 FLIGHT NO. C-416 GROUND LEVEL ALTITUDE (M)= 0

ALTITUDE (M)	FILTERS	TOTAL VOLUME SCATTERING COEFFICIENT (PER M)			
		2	4	3	5
1530	3.03E-04	1.47E-04	1.29E-04	7.68E-05	
1560	2.42E-04	1.37E-04	1.52E-04	6.73E-05	
1590	2.76E-04	1.30E-04	1.62E-04	8.24E-05	
1620	2.83E-04	1.09E-04	2.81E-04	8.30E-05	
1650	2.56E-04	9.06E-05	1.43E-04	8.36E-05	
1680	3.10E-04	1.57E-04	1.33E-04	8.27E-05	
1710	3.16E-04	2.05E-04	1.60E-04	8.59E-05	
1740	3.22E-04	1.91E-04	9.10E-05	8.92E-05	
1770	3.05E-04	2.04E-04	1.61E-04	7.26E-05	
1800	2.87E-04	1.94E-04	1.67E-04	6.96E-05	
1830	2.84E-04	2.10E-04	1.38E-04	7.06E-05	
1860	3.16E-04	1.85E-04	1.25E-04	6.73E-05	
1890	3.24E-04	1.77E-04	1.38E-04	7.51E-05	
1920	3.16E-04	1.74E-04	1.55E-04	6.62E-05	
1950	3.09E-04	1.72E-04	1.60E-04	5.73E-05	
1980	3.12E-04	1.75E-04	1.41E-04	6.10E-05	
2010	2.96E-04	1.74E-04	1.29E-04	6.29E-05	
2040	2.95E-04	1.68E-04	1.19E-04	6.62E-05	
2070	2.32E-04	1.60E-04	1.38E-04	6.20E-05	
2100	2.04E-04	1.60E-04	1.34E-04	6.05E-05	
2130	2.23E-04	1.56E-04	1.22E-04	5.34E-05	
2160	2.45E-04	1.63E-04	1.27E-04	4.72E-05	
2190	2.44E-04	1.74E-04	1.39E-04	4.74E-05	
2220	2.60E-04	1.62E-04	1.46E-04	4.83E-05	
2250	1.41E-04	1.61E-04	1.46E-04	4.34E-05	
2280	1.26E-04	1.59E-04	1.42E-04	4.42E-05	
2310	1.28E-04	1.84E-04	1.30E-04	4.26E-05	
2340	1.45E-04	1.28E-04	1.45E-04	4.28E-05	
2370	1.54E-04	9.75E-05	1.28E-04	3.93E-05	
2400	1.66E-04	1.18E-04	1.36E-04	4.21E-05	
2430	1.48E-04	9.29E-05	1.44E-04	3.65E-05	
2460	1.41E-04	9.82E-05	1.65E-04	4.01E-05	
2490	1.78E-04	8.33E-05	1.86E-04	5.50E-05	
2520	1.81E-04	8.17E-05	1.65E-04	5.26E-05	
2550	1.69E-04	8.03E-05	1.95E-04	5.73E-05	
2580	2.08E-04	7.36E-05	1.77E-04	5.18E-05	
2610	2.53E-04	7.65E-05	1.85E-04	8.13E-05	
2640	2.64E-04	7.27E-05	2.00E-04	9.32E-05	
2670	2.85E-04	7.82E-05	1.69E-04	9.17E-05	
2700	2.61E-04	7.12E-05	1.16E-04	9.03E-05	
2730	2.37E-04	7.37E-05	1.22E-04	8.88E-05	
2760	2.13E-04	7.61E-05	1.25E-04	7.20E-05	
2790	2.63E-04	7.49E-05	9.25E-05	8.32E-05	
2820	2.21E-04	7.43E-05	5.53E-05	5.19E-05	
2850	1.80E-04	7.37E-05	6.85E-05	5.31E-05	
2880	1.71E-04	6.57E-05	5.39E-05	4.40E-05	
2910	1.78E-04	7.62E-05	4.90E-05	3.51E-05	
2940	1.64E-04	7.41E-05	5.00E-05	3.96E-05	
2970	1.46E-04	8.23E-05	5.31E-05	3.94E-05	
3000	1.63E-04	8.83E-05	6.25E-05	3.91E-05	

## FLIGHT NO. C-416 TOTAL VOLUME SCATTERING COEFFICIENT

(JOB 9471 DATE 06/15/78)  
DATE 80177 FLIGHT NO. C-416 GROUND LEVEL ALTITUDE (M)= 0

ALTITUDE (M)	TOTAL VOLUME SCATTERING COEFFICIENT (PER M)				
	FILTERS	2	4	3	5
3030		1.77E-04	9.91E-05	5.30E-05	5.04E-05
3060		2.01E-04	8.87E-05	8.00E-05	4.17E-05
3090		1.80E-04	1.05E-04	7.45E-05	5.20E-05
3120		1.86E-04	1.21E-04	8.07E-05	5.22E-05
3150		2.09E-04	1.17E-04	5.80E-05	6.27E-05
3180		1.93E-04	1.25E-04	7.20E-05	5.64E-05
3210		1.85E-04	1.13E-04	6.06E-05	5.20E-05
3240		1.84E-04	1.11E-04	7.35E-05	5.56E-05
3270		1.92E-04	1.07E-04	5.18E-05	4.78E-05
3300		1.89E-04	1.12E-04	7.66E-05	4.46E-05
3330		1.95E-04	1.08E-04	7.54E-05	3.97E-05
3360		1.86E-04	1.13E-04	7.42E-05	4.39E-05
3390		1.58E-04	1.17E-04	6.70E-05	4.45E-05
3420		1.74E-04	1.01E-04	8.28E-05	4.52E-05
3450		1.68E-04	9.79E-05	7.35E-05	5.13E-05
3480		1.67E-04	9.93E-05	7.58E-05	4.89E-05
3510		1.65E-04	1.01E-04	8.74E-05	4.65E-05
3540		1.64E-04	8.93E-05	8.48E-05	4.98E-05
3570		1.84E-04	9.53E-05	7.61E-05	4.69E-05
3600		1.87E-04	9.97E-05	5.98E-05	4.91E-05
3630		1.94E-04	9.88E-05	7.81E-05	4.36E-05
3660		2.01E-04	9.79E-05	7.48E-05	5.01E-05
3690		1.51E-04	9.62E-05	7.93E-05	4.96E-05
3720		1.78E-04	1.03E-04	8.38E-05	4.97E-05
3750		1.84E-04	1.02E-04	7.94E-05	4.49E-05
3780		1.59E-04	1.01E-04	7.36E-05	5.03E-05
3810		1.62E-04	1.19E-04	7.52E-05	4.80E-05
3840		1.54E-04	1.18E-04	7.65E-05	4.67E-05
3870		1.58E-04	1.31E-04	7.42E-05	4.19E-05
3900		1.58E-04	1.19E-04	6.80E-05	4.61E-05
3930		1.56E-04	1.19E-04	6.40E-05	4.60E-05
3960		1.68E-04	1.05E-04	7.21E-05	4.40E-05
3990		1.42E-04	1.07E-04	6.24E-05	4.55E-05
4020		1.74E-04	1.08E-04	6.45E-05	4.70E-05
4050		1.69E-04	1.11E-04	6.78E-05	4.87E-05
4080		1.48E-04	1.13E-04	7.37E-05	5.21E-05
4110		1.52E-04	1.13E-04	6.30E-05	5.16E-05
4140		1.65E-04	1.19E-04	6.82E-05	5.10E-05
4170		1.65E-04	1.12E-04	7.12E-05	5.05E-05
4200		1.64E-04	1.10E-04	6.26E-05	4.99E-05
4230		1.67E-04	9.53E-05	6.32E-05	4.94E-05
4260		1.61E-04	1.01E-04	5.89E-05	4.88E-05
4290		1.55E-04	1.04E-04	5.96E-05	4.83E-05
4320		1.49E-04	1.01E-04	5.07E-05	4.66E-05
4350		1.40E-04	9.86E-05	5.42E-05	5.21E-05
4380		1.65E-04	9.12E-05	5.71E-05	4.22E-05
4410		1.43E-04	9.42E-05	4.82E-05	4.31E-05
4440		1.50E-04	9.71E-05	5.01E-05	4.57E-05
4470		1.55E-04	8.27E-05	4.98E-05	4.07E-05
4500		1.49E-04	8.85E-05	4.99E-05	3.91E-05

**FLIGHT NO. C-416**  
**TOTAL VOLUME SCATTERING COEFFICIENT**

(JOB 9471 DATE 06/15/78)  
 DATE 80177 FLIGHT NO. C-416 GROUND LEVEL ALTITUDE (M)= 0

ALTITUDE (M)	FILTERS	TOTAL VOLUME SCATTERING COEFFICIENT (PER M)			
		2	4	3	5
4530	1.51E-04	9.18E-05	5.00E-05	3.50E-05	
4560	1.43E-04	8.33E-05	4.81E-05	3.85E-05	
4590	1.47E-04	8.93E-05	5.04E-05	3.79E-05	
4620	(1.46E-04 )	8.11E-05	(5.03E-05 )	(3.78E-05 )	
4650	(1.46E-04 )	(8.09E-05 )	(5.01E-05 )	(3.77E-05 )	
4680	(1.45E-04 )	(8.06E-05 )	(5.00E-05 )	(3.76E-05 )	
4710	(1.45E-04 )	(8.04E-05 )	(4.98E-05 )	(3.75E-05 )	
4740	(1.44E-04 )	(8.01E-05 )	(4.96E-05 )	(3.73E-05 )	
4770	(1.44E-04 )	(7.99E-05 )	(4.95E-05 )	(3.72E-05 )	
4800	(1.43E-04 )	(7.96E-05 )	(4.93E-05 )	(3.71E-05 )	
FIRST DATA ALT	120	270	120	180	
LAST DATA ALT	4590	4620	4590	4590	

**FLIGHT NO. C-416  
EQUIVALENT ATTENUATION LENGTH**

(JOB 9471 DATE 06/15/78)  
DATE 80177 FLIGHT NO. C-416 GROUND LEVEL ALTITUDE (M)= 0

ALTITUDE (M)	FILTERS	EQUIVALENT ATTENUATION LENGTH (M)			
		2	4	3	5
0	2.49E 03	5.56E 03	7.34E 03	1.09E 04	
300	2.63E 03	5.66E 03	7.16E 03	1.09E 04	
600	2.67E 03	5.76E 03	6.83E 03	9.65E 03	
900	2.73E 03	5.87E 03	6.46E 03	8.71E 03	
1200	2.80E 03	5.98E 03	6.39E 03	8.70E 03	
1500	2.88E 03	6.10E 03	5.46E 03	9.07E 03	
1800	2.96E 03	6.16E 03	6.45E 03	9.51E 03	
2100	3.02E 03	6.08E 03	6.55E 03	1.01E 04	
2400	3.19E 03	6.14E 03	6.64E 03	1.08E 04	
2700	3.32E 03	6.49E 03	6.54E 03	1.12E 04	
3000	3.44E 03	6.84E 03	6.88E 03	1.16E 04	
3300	3.55E 03	7.00E 03	7.22E 03	1.20E 04	
3600	3.67E 03	7.17E 03	7.50E 03	1.25E 04	
3900	3.78E 03	7.30E 03	7.75E 03	1.29E 04	
4200	3.88E 03	7.39E 03	8.03E 03	1.33E 04	
4500	3.99E 03	7.54E 03	8.34E 03	1.36E 04	
4800	4.10E 03	7.72E 03	8.65E 03	1.41E 04	

**FLIGHT NO. C-416  
VERTICAL BEAM TRANSMITTANCE FROM GROUND TO ALTITUDE**

ALTITUDE (M)	FILTERS	VERTICAL BEAM TRANSMITTANCE FROM GROUND TO ALTITUDE			
		2	4	3	5
0	1.00E 00	1.00E 00	1.00E 00	1.00E 00	
300	8.92E-01	9.48E-01	9.59E-01	9.73E-01	
600	7.99E-01	9.01E-01	9.17E-01	9.40E-01	
900	7.19E-01	8.58E-01	8.70E-01	9.02E-01	
1200	6.51E-01	8.18E-01	8.29E-01	8.71E-01	
1500	5.94E-01	7.82E-01	7.93E-01	8.48E-01	
1800	5.44E-01	7.47E-01	7.57E-01	8.28E-01	
2100	4.98E-01	7.08E-01	7.26E-01	8.12E-01	
2400	4.72E-01	6.76E-01	6.97E-01	8.00E-01	
2700	4.43E-01	6.60E-01	6.62E-01	7.86E-01	
3000	4.18E-01	6.45E-01	6.47E-01	7.72E-01	
3300	3.95E-01	6.24E-01	6.33E-01	7.60E-01	
3600	3.75E-01	6.05E-01	6.19E-01	7.50E-01	
3900	3.56E-01	5.86E-01	6.05E-01	7.39E-01	
4200	3.39E-01	5.67E-01	5.93E-01	7.29E-01	
4500	3.24E-01	5.50E-01	5.83E-01	7.19E-01	
4800	3.10E-01	5.37E-01	5.74E-01	7.11E-01	

**FLIGHT C-418 - 4 AUGUST 1977 - DESCRIPTION OF FLIGHT & WEATHER CHARACTERISTICS**

Filter Ident	Data Interval			Solar Zenith Angle			Maximum Flight Altitude (m)	Average Terrain Elevation (m)
	Start (GMT)	End (GMT)	Elapsed (hrs)	Initial ST&LV (degrees)	Solar Transit (degrees)	Final V-PRO (degrees)		
2	0847	0905	0.3	48.3	-	45.9	4530	18
4	0910	0930	0.3	45.4	-	43.1	4590	18
3	0930	0949	0.3	43.1	-	41.1	4620	18
5	0953	1008	0.3	40.8	-	39.4	4560	18

Flight C-418 was a morning flight. There were several layers of low altitude clouds with high thin clouds as indicated by the photographs. The flight was run over the alternate Ahlhorn track due to inclement weather along the Meppen track.

The approximate east to west Ahlhorn track was located between Lathen and Ahlhorn in northwestern Germany. Typical terrain features were heavily cultivated low lying flat farmlands interspersed with occasional dark woods and small towns.

The in-flight observer reported scattered clouds bases 240-360 meters (800 to 1200 feet) with cumulus forming and building rapidly through the morning. By 0930 GMT cloud tops were 3000 meters (10,000 feet) or more. Numerous haze layers were noted. The slant range visibility was less than 5 miles at 1800 meters (6000 feet).

Ahlhorn, located at the east end of the flight track and 26 kilometers from the center of the track, reported 1/8 to 3/8 cumulus based at 300 to 540 meters (1000 to 1800 feet) and 3/8 to 5/8 stratocumulus with bases varying from 600 to 1500 meters (2000 to 5000 feet). Visibility was observed at 3.0 to 3.5 kilometers in haze.

Meppen, 40 kilometers southwest of the flight track center, reported 2/8 to 4/8 clouds at 360 to 600 meters (1200 to 2000 feet), 6/8 becoming 3/8 stratocumulus at 1200-1500 meters (4000 to 5000 feet) and 5/8 cirrus at 7500 meters (25,000 feet). Visibility of 1.8 kilometers in light fog gradually improved to 4.8 kilometers in haze.

The radiosonde station at Rheine/Waldhugel was 73 kilometers south and located in a prevailing airflow that was parallel to the track.

The surface chart showed ridging with a weak gradient across western Europe. A cold front was approaching the Irish coast. At 500 millibars there was an open low in eastern Spain with a trough south to Algiers. There was slight ridging through western Germany, Netherlands and Denmark. The airflow was westerly and the air mass was unstable maritime polar at low levels.

# FLIGHT NO. C-418

AHLHORN

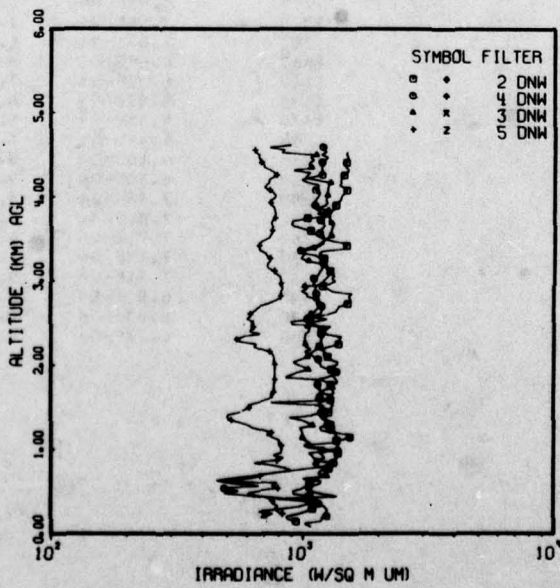
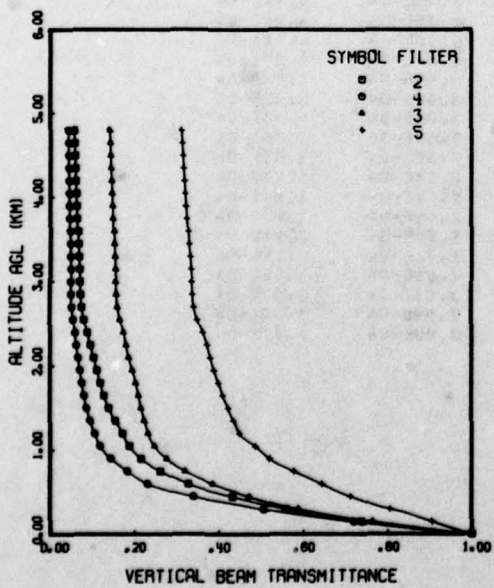
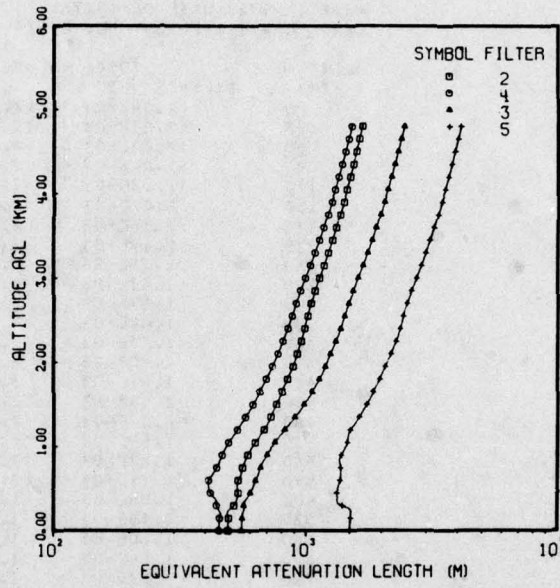
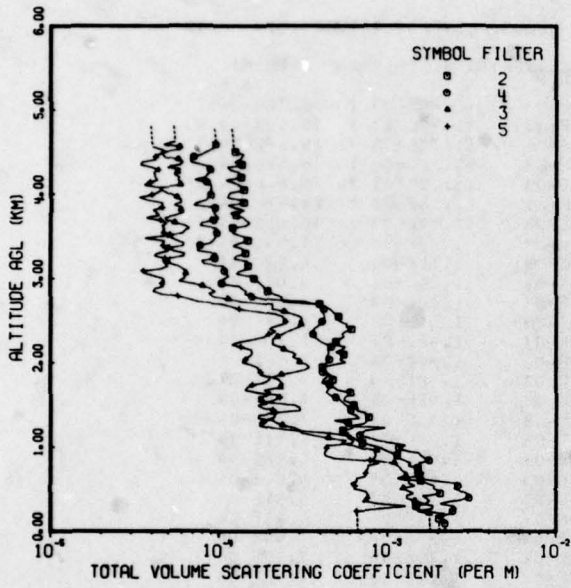

## FLIGHT NO. C-418 TOTAL VOLUME SCATTERING COEFFICIENT

(JOB 9723 DATE 06/13/78)  
DATE 80477 FLIGHT NO. C-418 GROUND LEVEL ALTITUDE (M)= 18

ALTITUDE (M)	TOTAL VOLUME SCATTERING COEFFICIENT (PER M)			
	FILTERS	2	4	3
0	(2.04E-03 )	(2.21E-03 )	(1.80E-03 )	(6.72E-04 )
30	(2.03E-03 )	(2.20E-03 )	(1.79E-03 )	(6.69E-04 )
60	(2.03E-03 )	(2.20E-03 )	(1.79E-03 )	(6.67E-04 )
90	(2.02E-03 )	2.19E-03	(1.78E-03 )	(6.65E-04 )
120	(2.02E-03 )	2.25E-03	(1.78E-03 )	(6.64E-04 )
150	2.01E-03	2.10E-03	(1.78E-03 )	(6.62E-04 )
180	2.16E-03	2.04E-03	(1.77E-03 )	(6.60E-04 )
210	2.17E-03	2.34E-03	1.77E-03	(6.59E-04 )
240	1.71E-03	2.43E-03	1.51E-03	6.57E-04
270	1.41E-03	2.55E-03	1.84E-03	9.05E-04
300	1.47E-03	2.46E-03	1.86E-03	1.28E-03
330	1.69E-03	2.05E-03	1.61E-03	8.67E-04
360	1.77E-03	2.39E-03	1.45E-03	7.10E-04
390	1.70E-03	3.04E-03	1.30E-03	7.59E-04
420	1.61E-03	3.11E-03	1.30E-03	7.71E-04
450	2.05E-03	2.90E-03	1.42E-03	7.54E-04
480	2.02E-03	2.70E-03	1.31E-03	7.33E-04
510	1.89E-03	2.51E-03	1.24E-03	6.41E-04
540	1.87E-03	2.61E-03	1.45E-03	6.42E-04
570	1.71E-03	2.63E-03	1.33E-03	6.02E-04
600	1.56E-03	1.93E-03	1.34E-03	6.61E-04
630	1.16E-03	1.50E-03	1.14E-03	6.53E-04
660	1.60E-03	1.50E-03	1.29E-03	7.45E-04
690	1.64E-03	1.51E-03	1.29E-03	7.39E-04
720	1.57E-03	1.52E-03	1.21E-03	7.53E-04
750	1.51E-03	1.53E-03	1.19E-03	7.66E-04
780	1.33E-03	1.53E-03	1.14E-03	7.69E-04
810	1.36E-03	1.54E-03	1.10E-03	8.88E-04
840	1.26E-03	1.76E-03	8.10E-04	7.90E-04
870	1.15E-03	1.66E-03	8.38E-04	4.77E-04
900	1.14E-03	1.57E-03	8.51E-04	4.25E-04
930	1.05E-03	1.52E-03	8.42E-04	4.21E-04
960	9.67E-04	1.25E-03	8.62E-04	4.29E-04
990	8.98E-04	1.16E-03	6.95E-04	4.34E-04
1020	7.94E-04	1.27E-03	6.28E-04	4.39E-04
1050	7.07E-04	1.06E-03	5.32E-04	6.11E-04
1080	6.65E-04	8.58E-04	5.67E-04	6.30E-04
1110	6.28E-04	7.66E-04	4.45E-04	5.83E-04
1140	5.81E-04	6.83E-04	3.68E-04	5.83E-04
1170	5.35E-04	6.83E-04	3.08E-04	4.53E-04
1200	5.41E-04	7.46E-04	3.00E-04	2.88E-04
1230	6.16E-04	9.62E-04	2.80E-04	2.05E-04
1260	6.30E-04	5.77E-04	2.38E-04	1.73E-04
1290	7.38E-04	5.83E-04	2.17E-04	1.80E-04
1320	7.54E-04	4.85E-04	2.06E-04	1.92E-04
1350	7.71E-04	6.73E-04	1.70E-04	2.11E-04
1380	7.43E-04	6.48E-04	1.72E-04	2.14E-04
1410	7.31E-04	5.86E-04	2.11E-04	2.18E-04
1440	6.52E-04	6.02E-04	3.03E-04	2.07E-04
1470	6.63E-04	6.08E-04	2.99E-04	1.80E-04
1500	6.27E-04	5.62E-04	2.80E-04	1.69E-04

**FLIGHT NO. C-418**  
**TOTAL VOLUME SCATTERING COEFFICIENT**

(JOB 9723 DATE 06/13/78) GROUND LEVEL ALTITUDE (M)= 18  
 DATE 80477 FLIGHT NO. C-418

ALTITUDE (M)	FILTERS	TOTAL VOLUME SCATTERING COEFFICIENT (PER M)			
		2	4	3	5
1530	5.93E-04	5.42E-04	1.97E-04	1.96E-04	
1560	5.49E-04	5.21E-04	1.77E-04	2.12E-04	
1590	5.56E-04	4.90E-04	1.71E-04	2.28E-04	
1620	5.82E-04	4.52E-04	1.94E-04	2.18E-04	
1650	6.03E-04	4.33E-04	2.02E-04	1.70E-04	
1680	5.09E-04	4.45E-04	1.85E-04	1.43E-04	
1710	4.80E-04	4.51E-04	2.32E-04	1.48E-04	
1740	4.50E-04	4.54E-04	2.41E-04	1.58E-04	
1770	4.06E-04	4.14E-04	2.33E-04	1.85E-04	
1800	4.74E-04	4.17E-04	2.26E-04	1.98E-04	
1830	4.74E-04	4.36E-04	2.06E-04	2.02E-04	
1860	4.53E-04	4.44E-04	2.35E-04	1.80E-04	
1890	4.30E-04	4.12E-04	2.80E-04	1.76E-04	
1920	4.08E-04	4.08E-04	3.24E-04	1.72E-04	
1950	4.10E-04	4.17E-04	3.44E-04	1.69E-04	
1980	4.74E-04	4.23E-04	3.30E-04	1.54E-04	
2010	5.64E-04	4.41E-04	3.01E-04	1.37E-04	
2040	5.22E-04	4.52E-04	2.99E-04	1.43E-04	
2070	5.46E-04	4.34E-04	2.72E-04	1.48E-04	
2100	5.50E-04	4.44E-04	2.87E-04	1.56E-04	
2130	4.92E-04	4.51E-04	2.68E-04	1.56E-04	
2160	5.40E-04	4.43E-04	2.42E-04	1.54E-04	
2190	5.58E-04	4.64E-04	2.29E-04	1.34E-04	
2220	4.92E-04	4.37E-04	2.07E-04	1.19E-04	
2250	4.93E-04	4.02E-04	2.08E-04	1.32E-04	
2280	5.15E-04	3.84E-04	2.07E-04	1.58E-04	
2310	5.53E-04	3.65E-04	2.22E-04	1.83E-04	
2340	5.37E-04	3.60E-04	2.37E-04	1.97E-04	
2370	5.55E-04	3.57E-04	2.52E-04	2.17E-04	
2400	6.11E-04	3.64E-04	2.75E-04	1.98E-04	
2430	5.70E-04	3.82E-04	3.00E-04	2.13E-04	
2460	5.72E-04	3.97E-04	3.06E-04	2.39E-04	
2490	5.27E-04	4.08E-04	3.00E-04	2.48E-04	
2520	5.05E-04	4.18E-04	3.11E-04	2.41E-04	
2550	5.10E-04	4.22E-04	3.04E-04	2.37E-04	
2580	4.87E-04	4.18E-04	2.72E-04	2.13E-04	
2610	4.71E-04	4.06E-04	2.43E-04	1.72E-04	
2640	4.53E-04	4.17E-04	2.05E-04	1.30E-04	
2670	4.23E-04	4.13E-04	2.07E-04	1.17E-04	
2700	3.92E-04	3.80E-04	2.05E-04	1.04E-04	
2730	2.39E-04	3.15E-04	1.35E-04	7.37E-05	
2760	2.35E-04	1.86E-04	1.13E-04	6.53E-05	
2790	2.31E-04	1.55E-04	9.17E-05	5.69E-05	
2820	2.08E-04	1.42E-04	8.72E-05	4.53E-05	
2850	1.94E-04	1.46E-04	9.54E-05	4.08E-05	
2880	1.90E-04	1.37E-04	8.90E-05	4.18E-05	
2910	1.83E-04	1.32E-04	8.01E-05	4.69E-05	
2940	1.77E-04	1.04E-04	7.06E-05	4.59E-05	
2970	1.69E-04	1.02E-04	5.81E-05	4.73E-05	
3000	1.61E-04	1.08E-04	6.22E-05	4.68E-05	

## FLIGHT NO. C-418 TOTAL VOLUME SCATTERING COEFFICIENT

(JOB 9723 DATE 06/13/78)  
DATE 80477 FLIGHT NO. C-418 GROUND LEVEL ALTITUDE (M)= 18

ALTITUDE (M)	TOTAL VOLUME SCATTERING COEFFICIENT (PER M)				
	FILTERS	2	4	3	5
3030		1.53E-04	1.14E-04	6.31E-05	4.14E-05
3060		1.27E-04	1.09E-04	6.37E-05	3.66E-05
3090		1.33E-04	1.08E-04	6.34E-05	3.56E-05
3120		1.50E-04	1.07E-04	6.03E-05	4.56E-05
3150		1.49E-04	1.06E-04	5.72E-05	4.96E-05
3180		1.46E-04	8.13E-05	5.05E-05	4.78E-05
3210		1.48E-04	7.91E-05	4.92E-05	4.66E-05
3240		1.23E-04	9.42E-05	5.11E-05	4.60E-05
3270		1.27E-04	9.68E-05	6.18E-05	4.13E-05
3300		1.44E-04	9.62E-05	6.24E-05	4.33E-05
3330		1.41E-04	7.46E-05	5.34E-05	4.97E-05
3360		1.36E-04	7.50E-05	5.00E-05	4.78E-05
3390		1.21E-04	7.70E-05	6.12E-05	4.65E-05
3420		1.32E-04	8.92E-05	6.16E-05	4.66E-05
3450		1.48E-04	9.18E-05	5.63E-05	4.74E-05
3480		1.50E-04	9.43E-05	5.19E-05	3.63E-05
3510		1.33E-04	9.56E-05	5.09E-05	4.78E-05
3540		1.21E-04	9.69E-05	6.09E-05	4.71E-05
3570		1.20E-04	9.79E-05	6.29E-05	4.64E-05
3600		1.20E-04	9.61E-05	6.64E-05	4.74E-05
3630		1.45E-04	7.70E-05	6.25E-05	4.62E-05
3660		1.52E-04	7.98E-05	5.46E-05	4.89E-05
3690		1.44E-04	9.26E-05	4.90E-05	4.49E-05
3720		1.40E-04	9.92E-05	4.78E-05	3.69E-05
3750		1.26E-04	9.55E-05	5.51E-05	4.40E-05
3780		1.16E-04	9.32E-05	6.09E-05	4.21E-05
3810		1.39E-04	9.09E-05	5.91E-05	4.01E-05
3840		1.22E-04	9.39E-05	5.90E-05	4.55E-05
3870		1.12E-04	7.00E-05	5.38E-05	4.53E-05
3900		1.39E-04	7.45E-05	5.93E-05	4.57E-05
3930		1.37E-04	8.31E-05	5.86E-05	3.73E-05
3960		1.11E-04	8.63E-05	5.65E-05	3.34E-05
3990		1.14E-04	8.94E-05	5.26E-05	3.99E-05
4020		1.16E-04	9.05E-05	4.86E-05	4.31E-05
4050		1.41E-04	8.96E-05	4.55E-05	4.58E-05
4080		1.37E-04	8.94E-05	4.52E-05	4.43E-05
4110		1.30E-04	8.92E-05	5.90E-05	3.60E-05
4140		1.21E-04	8.41E-05	5.88E-05	3.89E-05
4170		1.09E-04	7.14E-05	5.69E-05	4.31E-05
4200		1.35E-04	8.25E-05	5.82E-05	4.16E-05
4230		1.33E-04	8.51E-05	5.43E-05	4.13E-05
4260		1.30E-04	8.76E-05	5.66E-05	4.11E-05
4290		1.15E-04	8.87E-05	5.89E-05	4.35E-05
4320		1.12E-04	8.78E-05	4.92E-05	3.93E-05
4350		1.36E-04	7.84E-05	5.89E-05	3.40E-05
4380		1.23E-04	6.78E-05	6.07E-05	3.49E-05
4410		1.33E-04	6.75E-05	5.71E-05	4.17E-05
4440		1.36E-04	7.04E-05	4.74E-05	4.19E-05
4470		1.39E-04	7.89E-05	4.61E-05	4.38E-05
4500		1.24E-04	8.39E-05	4.54E-05	4.80E-05

**FLIGHT NO. C-418**  
**TOTAL VOLUME SCATTERING COEFFICIENT**

(JOB 9723 DATE 06/13/78)  
 DATE 80477 FLIGHT NO. C-418 GROUND LEVEL ALTITUDE (M)= 18

ALTITUDE (M)	FILTERS	TOTAL VOLUME SCATTERING COEFFICIENT (PER M)			
		2	4	3	5
4530	1.21E-04	9.00E-05	5.85E-05	4.54E-05	
4560	(1.21E-04 )	9.26E-05	5.84E-05	4.01E-05	
4590	(1.21E-04 )	9.52E-05	4.67E-05	(4.00E-05 )	
4620	(1.20E-04 )	(9.49E-05 )	5.45E-05	(3.99E-05 )	
4650	(1.20E-04 )	(9.46E-05 )	(5.43E-05 )	(3.97E-05 )	
4680	(1.19E-04 )	(9.43E-05 )	(5.42E-05 )	(3.96E-05 )	
4710	(1.19E-04 )	(9.40E-05 )	(5.40E-05 )	(3.95E-05 )	
4740	(1.19E-04 )	(9.37E-05 )	(5.38E-05 )	(3.94E-05 )	
4770	(1.18E-04 )	(9.35E-05 )	(5.37E-05 )	(3.92E-05 )	
4800	(1.18E-04 )	(9.32E-05 )	(5.35E-05 )	(3.91E-05 )	
FIRST DATA ALT	150	90	210	240	
LAST DATA ALT	4530	4590	4620	4560	

**FLIGHT NO. C-418  
EQUIVALENT ATTENUATION LENGTH**

(JOB 9723 DATE 06/13/78)  
DATE 80477 FLIGHT NO. C-418 GROUND LEVEL ALTITUDE (M)= 18

ALTITUDE (M)	EQUIVALENT ATTENUATION LENGTH (M)			
	FILTERS	2	4	3
0	4.90E 02	4.52E 02	5.55E 02	1.49E 03
300	5.18E 02	4.42E 02	5.66E 02	1.39E 03
600	5.38E 02	4.10E 02	6.31E 02	1.37E 03
900	5.88E 02	4.65E 02	7.01E 02	1.38E 03
1200	6.81E 02	5.33E 02	8.23E 02	1.50E 03
1500	7.62E 02	6.15E 02	9.81E 02	1.74E 03
1800	8.46E 02	6.97E 02	1.13E 03	1.96E 03
2100	9.25E 02	7.75E 02	1.25E 03	2.17E 03
2400	9.88E 02	8.47E 02	1.37E 03	2.37E 03
2700	1.05E 03	9.14E 02	1.48E 03	2.51E 03
3000	1.13E 03	9.99E 02	1.62E 03	2.75E 03
3300	1.23E 03	1.09E 03	1.76E 03	2.99E 03
3600	1.32E 03	1.18E 03	1.90E 03	3.22E 03
3900	1.41E 03	1.26E 03	2.04E 03	3.45E 03
4200	1.50E 03	1.35E 03	2.18E 03	3.68E 03
4500	1.58E 03	1.43E 03	2.32E 03	3.90E 03
4800	1.67E 03	1.52E 03	2.45E 03	4.12E 03

**FLIGHT NO. C-418  
VERTICAL BEAM TRANSMITTANCE FROM GROUND TO ALTITUDE**

ALTITUDE (M)	VERTICAL BEAM TRANSMITTANCE FROM GROUND TO ALTITUDE			
	FILTERS	2	4	3
0	1.00E 00	1.00E 00	1.00E 00	1.00E 00
300	5.60E-01	5.07E-01	5.89E-01	8.06E-01
600	3.28E-01	2.32E-01	3.87E-01	6.45E-01
900	2.16E-01	1.44E-01	2.77E-01	5.21E-01
1200	1.72E-01	1.05E-01	2.33E-01	4.49E-01
1500	1.40E-01	8.71E-02	2.17E-01	4.23E-01
1800	1.19E-01	7.57E-02	2.04E-01	4.00E-01
2100	1.03E-01	6.65E-02	1.87E-01	3.81E-01
2400	8.81E-02	5.89E-02	1.74E-01	3.63E-01
2700	7.57E-02	5.21E-02	1.61E-01	3.42E-01
3000	7.11E-02	4.96E-02	1.56E-01	3.36E-01
3300	6.82E-02	4.81E-02	1.53E-01	3.32E-01
3600	6.55E-02	4.69E-02	1.51E-01	3.27E-01
3900	6.29E-02	4.56E-02	1.48E-01	3.23E-01
4200	6.06E-02	4.45E-02	1.46E-01	3.19E-01
4500	5.83E-02	4.34E-02	1.44E-01	3.15E-01
4800	5.63E-02	4.23E-02	1.41E-01	3.11E-01

FLIGHT C-419 - 4 AUGUST 1977 - DESCRIPTION OF FLIGHT & WEATHER CHARACTERISTICS

Filter Ident	Data Interval			Solar Zenith Angle			Maximum Flight Altitude (m)	Average Terrain Elevation (m)
	Start (GMT)	End (GMT)	Elapsed (hrs)	Initial ST&LV (degrees)	Solar Transit (degrees)	Final V-PRO (degrees)		
2 & 3	1436	1518	0.7	50.1	-	56.0	750	18
4 & 5	1524	1608	0.7	56.8	-	63.4	750	18

Flight C-419 was an afternoon flight. There were scattered cumulus clouds in the process of dissipation and scattered cirrus.

The approximate northeast to southwest Meppen track was located between Oldenburg and Lathen in northwestern Germany. Typical terrain features were heavily cultivated low lying flat farmlands interspersed with occasional dark woods and small towns.

The in-flight observer reported scattered cloud bases at 1050 meters (3500 feet). These clouds were in the dissipation stage gradually becoming less. There was moderate haze at all flight altitudes. The slant range visibility was 5 to 7 miles at 300 meters (1000 feet) and 6 miles at 750 meters (2500 feet).

Oldenburg, 42 kilometers eastnortheast of the flight track center, reported 2/8 to 1/8 cumulus based at 1050 meters (3500 feet) and 4/8 to 3/8 cirrus at 7500 meters (25,000 feet). Visibility was observed as 6.0 to 7.0 kilometers in haze.

Ahlhorn, 43 kilometers eastsoutheast of the flight track center, reported two layers of cumulus with 1/8 based at 750 meters (2500 feet) and 3/8 based at 1050 meters (3500 feet) early in the afternoon. At 1544 GMT the observation was 2/8 cumulus at 1050 meters (3500 feet). Visibility of 6.0 kilometers in haze improved to 11.2 kilometers by 1544 GMT.

Meppen, 39 kilometers southwest of the flight track center, had 4/8 cumulus based at 1200 meters (4000 feet) and 11.2 kilometers visibility.

The radiosonde station at Rheine/Waldhugel was 82 kilometers south and located in a prevailing airflow that was parallel to the track.

The surface chart showed ridging with a weak gradient across western Europe. A cold front was approaching the Irish coast. At 500 millibars there was an open low in eastern Spain with a trough south to Algiers. There was slight ridging through western Germany, Netherlands and Denmark. The airflow was westerly and the air mass was unstable maritime polar.

# FLIGHT NO. C-419

MEPPEN

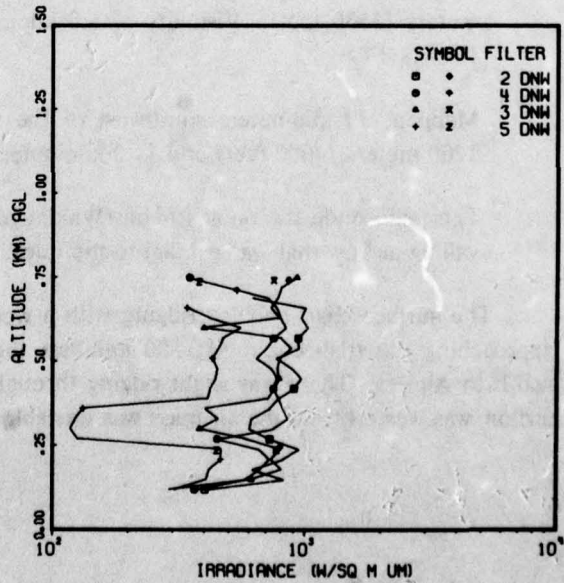
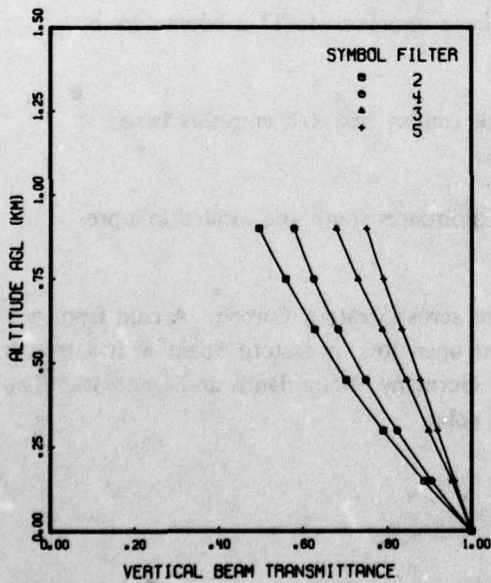
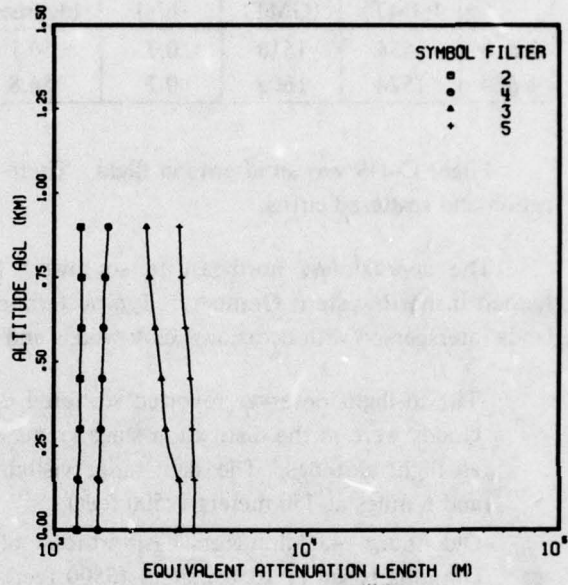
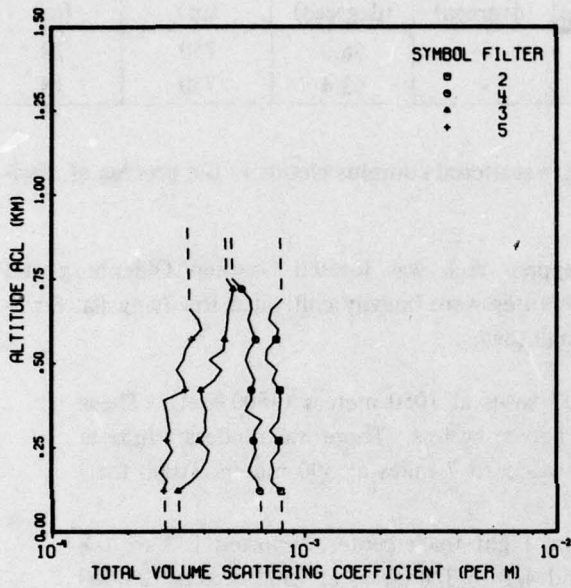

**FLIGHT NO. C-419**  
**TOTAL VOLUME SCATTERING COEFFICIENT**

(JOB 9723 DATE 06/13/78)  
 DATE 80477 FLIGHT NO. C-419 GROUND LEVEL ALTITUDE (M)= 18

ALTITUDE (M)	TOTAL VOLUME SCATTERING COEFFICIENT (PER M)			
	FILTERS	2	4	3
0	(8.16E-04 )	(6.75E-04 )	(3.20E-04 )	(2.81E-04 )
30	(8.12E-04 )	(6.71E-04 )	(3.18E-04 )	(2.79E-04 )
60	(8.10E-04 )	(6.70E-04 )	(3.17E-04 )	(2.79E-04 )
90	(8.08E-04 )	(6.68E-04 )	(3.17E-04 )	(2.78E-04 )
120	8.06E-04	6.66E-04	3.16E-04	2.77E-04
150	7.44E-04	6.50E-04	3.58E-04	2.87E-04
180	7.59E-04	6.04E-04	3.92E-04	2.68E-04
210	7.41E-04	6.25E-04	4.12E-04	2.85E-04
240	7.96E-04	6.47E-04	4.22E-04	3.01E-04
270	7.95E-04	6.32E-04	3.85E-04	2.85E-04
300	7.34E-04	6.41E-04	4.09E-04	2.94E-04
330	7.92E-04	6.82E-04	4.06E-04	2.89E-04
360	8.04E-04	5.87E-04	4.12E-04	2.86E-04
390	8.09E-04	6.19E-04	3.95E-04	2.79E-04
420	8.04E-04	6.20E-04	3.91E-04	3.39E-04
450	7.52E-04	6.38E-04	4.41E-04	3.33E-04
480	7.83E-04	6.11E-04	4.71E-04	3.13E-04
510	7.07E-04	5.88E-04	4.23E-04	3.33E-04
540	7.13E-04	6.07E-04	4.82E-04	3.40E-04
570	7.77E-04	6.44E-04	4.85E-04	3.60E-04
600	7.92E-04	6.20E-04	4.95E-04	3.93E-04
630	7.28E-04	6.02E-04	5.00E-04	3.81E-04
660	7.46E-04	6.21E-04	5.02E-04	3.53E-04
690	8.17E-04	6.12E-04	5.18E-04	(3.52E-04 )
720	(8.15E-04 )	5.66E-04	5.25E-04	(3.51E-04 )
750	(8.12E-04 )	5.21E-04	4.94E-04	(3.50E-04 )
780	(8.10E-04 )	(5.19E-04 )	(4.93E-04 )	(3.49E-04 )
810	(8.08E-04 )	(5.18E-04 )	(4.91E-04 )	(3.48E-04 )
840	(8.05E-04 )	(5.16E-04 )	(4.90E-04 )	(3.47E-04 )
870	(8.03E-04 )	(5.15E-04 )	(4.88E-04 )	(3.46E-04 )
900	(8.00E-04 )	(5.15E-04 )	(4.87E-04 )	(3.45E-04 )
FIRST DATA ALT	120	120	120	120
LAST DATA ALT	690	750	750	660

**FLIGHT NO. C-419**  
**EQUIVALENT ATTENUATION LENGTH**

(JOB 9723 DATE 06/13/78)  
 DATE 80477 FLIGHT NO. C-419 GROUND LEVEL ALTITUDE (M) = 18

ALTITUDE (M)	FILTERS	EQUIVALENT ATTENUATION LENGTH (M)				
	2	4	3	5	18	
0	1.23E 03	1.48E 03	3.13E 03	3.56E 03		
300	1.27E 03	1.54E 03	2.78E 03	3.54E 03		
600	1.29E 03	1.57E 03	2.51E 03	3.31E 03		
900	1.28E 03	1.64E 03	2.32E 03	3.13E 03		

**FLIGHT NO. C-419**  
**VERTICAL BEAM TRANSMITTANCE FROM GROUND TO ALTITUDE**

ALTITUDE (M)	FILTERS	VERTICAL BEAM TRANSMITTANCE FROM GROUND TO ALTITUDE				
	2	4	3	5	18	
0	1.00E 00	1.00E 00	1.00E 00	1.00E 00		
300	7.90E-01	8.23E-01	8.98E-01	9.19E-01		
600	6.27E-01	6.83E-01	7.88E-01	8.34E-01		
900	4.94E-01	5.78E-01	6.78E-01	7.50E-01		

FLIGHT C-420 - 5 AUGUST 1977 - DESCRIPTION OF FLIGHT & WEATHER CHARACTERISTICS

Filter Ident	Data Interval			Solar Zenith Angle			Maximum Flight Altitude (m)	Average Terrain Elevation (m)
	Start (GMT)	End (GMT)	Elapsed (hrs)	Initial ST&LV (degrees)	Solar Transit (degrees)	Final V-PRO (degrees)		
2 & 3	0840	0957	1.3	49.6	-	40.7	3060	18
4 & 5	1002	1119	1.3	40.4	-	36.2	3060	18

Flight C-420 was a morning flight. There were multiple layers of clouds varying from scattered at low levels to broken to overcast high clouds.

The approximate northeast to southwest Meppen track was located between Oldenburg and Lathen in northwestern Germany. Typical terrain features were heavily cultivated low lying flat farmlands interspersed with occasional dark woods and small towns.

The in-flight observer reported scattered variable broken thin cirrus becoming denser in late morning. Scattered altostratus formed at 4200 meters (14,000 feet) after 1100 GMT. Multiple haze layers were observed over the entire track. Slant range visibility varied from a low of 6 miles at 1050 meters (3500 feet) to a high of 30 miles at 3000 meters (10,000 feet).

Oldenburg, 42 kilometers eastnortheast of the flight track center, reported 1/8 to 3/8 altocumulus at 2700 to 3000 meters (9000 to 10,000 feet) and 3/8 to 7/8 cirrus at 7500 meters (25,000 feet). 1/8 cumulus formed at 1200 meters (4000 feet) after 0944 GMT. Visibility was reported as 11.2 kilometers.

Ahlhorn, 43 kilometers eastsoutheast of the flight track center, reported 1/8 to 2/8 altocumulus at 3900 meters (13,000 feet) and 5/8 to 7/8 cirrus at 7500 meters (25,000 feet). Visibility of 7.0 kilometers in early morning haze gradually improved to 11.2 kilometers by 0844 GMT.

Meppen, 39 kilometers southwest of the flight track center, reported 1/8 altocumulus at 3000 meters (10,000 feet) and 3/8 to 5/8 cirrus at 7500 meters (25,000 feet). Visibility was observed as 11.2 kilometers.

The radiosonde station at Rheine/Waldhugel was 82 kilometers south and upstream from the flight track center.

The surface chart showed a cold front that extended along a line from Bergen to London to Brest and then into the Atlantic. There was an open low over Rome with a weak trough northnorthwest to the North Sea. The 500 millibar chart had a low over Iceland with a trough southeast to Britain. There was a weak ridge from western Germany to Sweden. The flow was southwesterly and the air mass was modified stable maritime polar.

# FLIGHT NO. C-420

MEPPEN

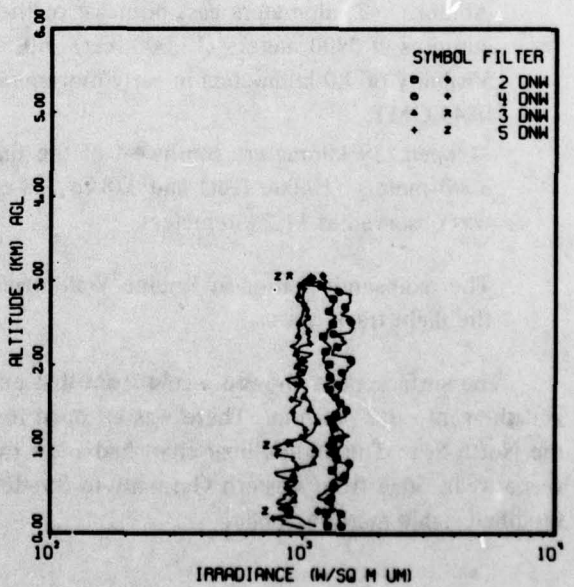
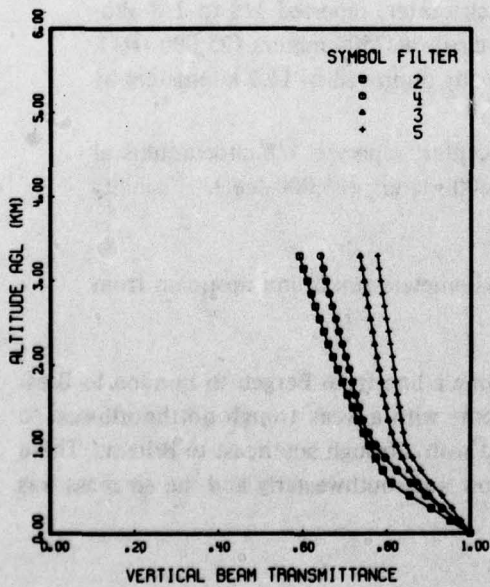
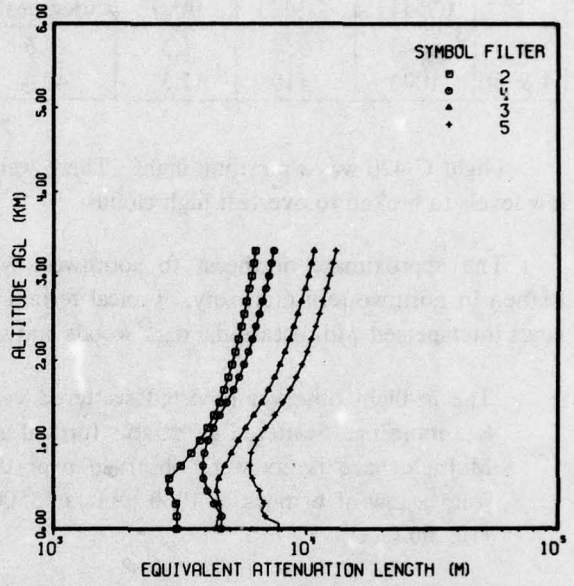
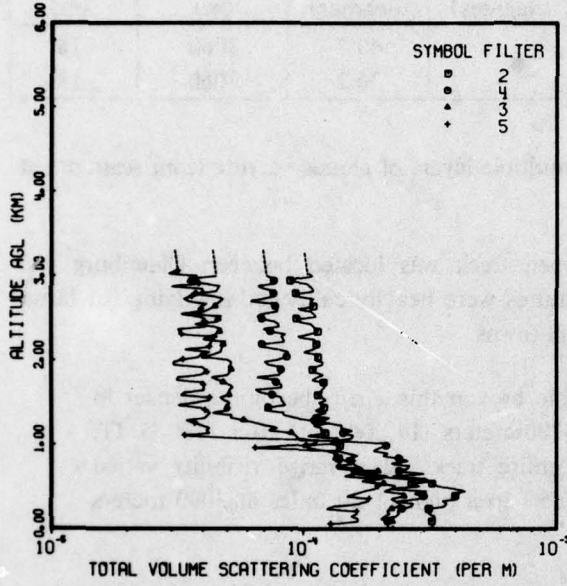

## FLIGHT NO. C-420 TOTAL VOLUME SCATTERING COEFFICIENT

(JOB 9489 DATE 06/15/78)  
DATE 80577 FLIGHT NO. C-420 GROUND LEVEL ALTITUDE (M)= 18

ALTITUDE (M)	TOTAL VOLUME SCATTERING COEFFICIENT (PER M)			
	FILTERS	2	4	3
0	(3.25E-04)	(2.17E-04)	(2.27E-04)	(1.29E-04)
30	(3.23E-04)	(2.16E-04)	(2.26E-04)	(1.28E-04)
60	(3.23E-04)	(2.15E-04)	(2.25E-04)	1.28E-04
90	3.22E-04	2.15E-04	2.25E-04	1.64E-04
120	3.27E-04	2.08E-04	2.03E-04	1.64E-04
150	3.31E-04	2.33E-04	2.11E-04	1.55E-04
180	3.14E-04	2.39E-04	2.19E-04	1.63E-04
210	3.12E-04	2.36E-04	2.14E-04	1.62E-04
240	3.13E-04	2.45E-04	2.23E-04	1.24E-04
270	3.60E-04	2.68E-04	2.37E-04	1.33E-04
300	3.69E-04	2.72E-04	2.42E-04	1.67E-04
330	3.57E-04	2.38E-04	2.33E-04	1.80E-04
360	4.10E-04	2.86E-04	2.23E-04	1.82E-04
390	3.98E-04	2.99E-04	2.50E-04	1.49E-04
420	3.87E-04	2.75E-04	2.48E-04	1.61E-04
450	4.37E-04	3.07E-04	2.09E-04	1.74E-04
480	3.93E-04	2.20E-04	2.26E-04	1.93E-04
510	3.39E-04	2.87E-04	2.30E-04	1.97E-04
540	3.22E-04	2.67E-04	2.08E-04	1.95E-04
570	3.30E-04	3.15E-04	1.71E-04	1.75E-04
600	2.56E-04	3.02E-04	1.93E-04	2.02E-04
630	1.91E-04	2.26E-04	1.46E-04	2.14E-04
660	1.60E-04	2.99E-04	1.63E-04	1.82E-04
690	1.60E-04	2.38E-04	1.97E-04	1.66E-04
720	1.60E-04	2.59E-04	1.37E-04	1.71E-04
750	1.36E-04	2.62E-04	1.35E-04	1.62E-04
780	1.56E-04	2.23E-04	1.39E-04	1.57E-04
810	1.48E-04	2.60E-04	1.41E-04	1.57E-04
840	1.38E-04	2.39E-04	1.34E-04	1.48E-04
870	1.32E-04	2.07E-04	1.39E-04	1.65E-04
900	1.34E-04	2.16E-04	1.35E-04	1.49E-04
930	1.34E-04	1.90E-04	1.24E-04	1.37E-04
960	1.40E-04	1.99E-04	1.06E-04	6.44E-05
990	1.40E-04	2.13E-04	1.02E-04	8.65E-05
1020	1.28E-04	2.05E-04	1.12E-04	1.40E-04
1050	1.40E-04	1.37E-04	1.14E-04	1.36E-04
1080	1.36E-04	1.55E-04	9.53E-05	5.15E-05
1110	1.04E-04	1.58E-04	9.29E-05	3.39E-05
1140	1.22E-04	1.43E-04	8.97E-05	4.25E-05
1170	1.17E-04	1.56E-04	7.29E-05	4.14E-05
1200	1.18E-04	1.41E-04	7.90E-05	4.24E-05
1230	1.10E-04	1.42E-04	7.08E-05	3.97E-05
1260	1.24E-04	1.26E-04	6.45E-05	3.71E-05
1290	1.18E-04	1.11E-04	5.81E-05	3.45E-05
1320	1.27E-04	9.29E-05	5.16E-05	4.09E-05
1350	1.09E-04	8.36E-05	5.20E-05	4.19E-05
1380	1.22E-04	8.30E-05	4.37E-05	4.27E-05
1410	1.12E-04	7.03E-05	5.06E-05	4.09E-05
1440	1.21E-04	7.25E-05	4.99E-05	3.91E-05
1470	1.20E-04	8.50E-05	5.03E-05	3.19E-05
1500	1.15E-04	8.31E-05	5.08E-05	3.72E-05

## FLIGHT NO. C-420 TOTAL VOLUME SCATTERING COEFFICIENT

(JOB 9489 DATE 06/15/78)  
DATE 80577 FLIGHT NO. C-420 GROUND LEVEL ALTITUDE (M)= 18

ALTITUDE (M)	FILTERS	TOTAL VOLUME SCATTERING COEFFICIENT (PER M)			
		2	4	3	5
1530	1.23E-04	8.19E-05	4.84E-05	4.26E-05	
1560	1.19E-04	8.16E-05	4.67E-05	4.25E-05	
1590	1.14E-04	7.52E-05	5.09E-05	3.28E-05	
1620	1.18E-04	6.75E-05	5.09E-05	3.40E-05	
1650	1.18E-04	6.47E-05	5.08E-05	4.04E-05	
1680	1.21E-04	8.21E-05	5.28E-05	4.03E-05	
1710	1.21E-04	8.18E-05	5.10E-05	4.02E-05	
1740	1.20E-04	7.79E-05	4.82E-05	4.01E-05	
1770	1.08E-04	7.66E-05	4.58E-05	3.14E-05	
1800	1.13E-04	6.55E-05	4.34E-05	3.18E-05	
1830	1.20E-04	8.04E-05	5.02E-05	3.92E-05	
1860	1.12E-04	8.24E-05	5.10E-05	4.14E-05	
1890	1.09E-04	8.14E-05	5.19E-05	4.09E-05	
1920	1.11E-04	8.03E-05	5.06E-05	3.97E-05	
1950	1.19E-04	7.21E-05	5.17E-05	3.05E-05	
1980	1.19E-04	7.04E-05	5.19E-05	3.06E-05	
2010	1.11E-04	7.98E-05	4.94E-05	3.33E-05	
2040	1.14E-04	8.59E-05	4.05E-05	3.85E-05	
2070	1.14E-04	8.63E-05	4.42E-05	3.94E-05	
2100	1.00E-04	8.70E-05	4.72E-05	4.25E-05	
2130	1.09E-04	7.90E-05	4.72E-05	3.41E-05	
2160	1.14E-04	6.89E-05	4.77E-05	4.24E-05	
2190	1.13E-04	6.83E-05	4.81E-05	4.28E-05	
2220	1.12E-04	8.40E-05	4.91E-05	4.32E-05	
2250	1.10E-04	8.31E-05	4.01E-05	4.34E-05	
2280	9.52E-05	8.17E-05	4.25E-05	4.56E-05	
2310	1.05E-04	8.51E-05	4.50E-05	3.28E-05	
2340	1.14E-04	7.39E-05	4.66E-05	3.23E-05	
2370	1.12E-04	6.96E-05	4.70E-05	3.19E-05	
2400	1.10E-04	8.01E-05	4.43E-05	4.09E-05	
2430	1.07E-04	7.95E-05	3.74E-05	4.08E-05	
2460	9.66E-05	7.65E-05	4.57E-05	4.06E-05	
2490	9.37E-05	6.83E-05	4.60E-05	4.06E-05	
2520	1.12E-04	6.57E-05	4.72E-05	3.88E-05	
2550	1.10E-04	6.93E-05	3.63E-05	3.28E-05	
2580	1.07E-04	7.90E-05	4.06E-05	3.85E-05	
2610	9.53E-05	7.87E-05	4.26E-05	3.93E-05	
2640	1.10E-04	7.73E-05	4.47E-05	3.96E-05	
2670	1.10E-04	7.59E-05	4.56E-05	4.14E-05	
2700	1.07E-04	6.18E-05	4.69E-05	3.53E-05	
2730	1.10E-04	6.96E-05	4.83E-05	3.35E-05	
2760	9.55E-05	7.74E-05	4.42E-05	3.61E-05	
2790	9.32E-05	7.62E-05	3.75E-05	3.87E-05	
2820	1.09E-04	7.70E-05	4.53E-05	4.02E-05	
2850	1.09E-04	6.94E-05	4.58E-05	3.96E-05	
2880	1.06E-04	6.59E-05	4.64E-05	3.01E-05	
2910	1.02E-04	7.71E-05	4.06E-05	3.84E-05	
2940	8.82E-05	7.60E-05	3.54E-05	3.81E-05	
2970	9.35E-05	7.50E-05	3.61E-05	3.64E-05	
3000	1.09E-04	7.10E-05	4.49E-05	3.77E-05	

**FLIGHT NO. C-420**  
**TOTAL VOLUME SCATTERING COEFFICIENT**

(JOB 9489 DATE 06/15/78)  
 DATE 80577 FLIGHT NO. C-420 GROUND LEVEL ALTITUDE (M)= 18

ALTITUDE (M)	TOTAL VOLUME SCATTERING COEFFICIENT (PER M)				
	FILTERS	2	4	3	5
3030		1.03E-04	(7.08E-05 )	(4.47E-05 )	2.92E-05
3060		(1.03E-04 )	(7.06E-05 )	(4.46E-05 )	3.16E-05
3090		(1.02E-04 )	(7.03E-05 )	(4.45E-05 )	(3.15E-05 )
3120		(1.02E-04 )	(7.01E-05 )	(4.43E-05 )	(3.14E-05 )
3150		(1.02E-04 )	(6.99E-05 )	(4.42E-05 )	(3.13E-05 )
3180		(1.01E-04 )	(6.97E-05 )	(4.40E-05 )	(3.12E-05 )
3210		(1.01E-04 )	(6.95E-05 )	(4.39E-05 )	(3.11E-05 )
3240		(1.01E-04 )	(6.92E-05 )	(4.38E-05 )	(3.10E-05 )
3270		(1.00E-04 )	(6.90E-05 )	(4.36E-05 )	(3.09E-05 )
3300		(1.00E-04 )	(6.88E-05 )	(4.35E-05 )	(3.08E-05 )

FIRST DATA ALT	90	90	90	60
LAST DATA ALT	3030	3000	3000	3060

**FLIGHT NO. C-420  
EQUIVALENT ATTENUATION LENGTH**

(JOB 9489 DATE 06/15/78)  
DATE 80577 FLIGHT NO. C-420 GROUND LEVEL ALTITUDE (M)= 18

ALTITUDE (M)	EQUIVALENT ATTENUATION LENGTH (M)			
	FILTERS 2	4	3	5
0	3.08E 03	4.61E 03	4.41E 03	7.75E 03
300	3.06E 03	4.31E 03	4.51E 03	6.81E 03
600	2.87E 03	3.92E 03	4.51E 03	6.13E 03
900	3.52E 03	3.96E 03	5.06E 03	6.05E 03
1200	4.07E 03	4.30E 03	5.76E 03	6.91E 03
1500	4.54E 03	4.86E 03	6.67E 03	8.10E 03
1800	4.93E 03	5.43E 03	7.51E 03	9.15E 03
2100	5.26E 03	5.91E 03	8.26E 03	1.01E 04
2400	5.56E 03	6.34E 03	8.95E 03	1.09E 04
2700	5.82E 03	6.74E 03	9.61E 03	1.17E 04
3000	6.07E 03	7.10E 03	1.02E 04	1.24E 04
3300	6.29E 03	7.44E 03	1.07E 04	1.31E 04

**FLIGHT NO. C-420  
VERTICAL BEAM TRANSMITTANCE FROM GROUND TO ALTITUDE**

ALTITUDE (M)	VERTICAL BEAM TRANSMITTANCE FROM GROUND TO ALTITUDE			
	FILTERS 2	4	3	5
0	1.00E 00	1.00E 00	1.00E 00	1.00E 00
300	9.06E-01	9.33E-01	9.36E-01	9.57E-01
600	8.12E-01	8.58E-01	8.76E-01	9.07E-01
900	7.74E-01	7.97E-01	8.37E-01	8.62E-01
1200	7.45E-01	7.56E-01	8.12E-01	8.41E-01
1500	7.19E-01	7.34E-01	7.99E-01	8.31E-01
1800	6.94E-01	7.18E-01	7.87E-01	8.21E-01
2100	6.71E-01	7.01E-01	7.75E-01	8.12E-01
2400	6.49E-01	6.85E-01	7.65E-01	8.03E-01
2700	6.29E-01	6.70E-01	7.55E-01	7.94E-01
3000	6.10E-01	6.55E-01	7.45E-01	7.85E-01
3300	5.92E-01	6.42E-01	7.36E-01	7.78E-01

FLIGHT C-421 - 10 AUGUST 1977 - DESCRIPTION OF FLIGHT & WEATHER CHARACTERISTICS

Filter Ident	Data Interval			Solar Zenith Angle			Maximum Flight Altitude (m)	Average Terrain Elevation (m)
	Start (GMT)	End (GMT)	Elapsed (hrs)	Initial ST&LV (degrees)	Solar Transit (degrees)	Final V-PRO (degrees)		
2 & 3	1012	1210	2.0	41.4	39.2	40.4	5850	0
4 & 5	1218	1412	1.9	40.7	-	51.3	5850	0

Flight C-421 was a midday flight that spanned local apparent noon. There were scattered to broken clouds at several altitudes with more clouds over the land than over the water. The in-flight pictures show skies varying from scattered to broken thin clouds.

The approximate southeast to northwest Rodby track was located south of Lolland Island, Denmark. Typical terrain features along the nearby coast to the north of the track were flat, cultivated farmlands interspersed with occasional woods and small towns. Directly beneath the track and to the south were the relatively shallow waters of Femer Bay.

The in-flight observer reported clouds approaching the east end of the track from the south. Stratus cloud bases were 540 meters (1800 feet) and stratocumulus bases were 900 meters (3000 feet). A thin scattered cirrus layer increased to broken and became denser. There were multiple layers of light to moderate haze. The slant range visibility varied from 8-10 miles at 300 meters (1000 feet) to 25 miles at 5700 meters (19,000 feet).

Fehmarnbelt, 9 kilometers south of the track center point, reported 3/8 stratocumulus at 450 meters (1500 feet) at 0900 GMT increasing to 5/8 to 6/8 coverage with some cumulus after 1200 GMT. Visibility was 10.0 to 20.0 kilometers.

Schleswig, 103 kilometers west of the track center point, reported 5/8 cumulus with bases 450 meters (1500 feet) becoming 3/8 cumulus and cumulonimbus at 600 meters (2000 feet) after 1100 GMT. Ceilings of 990 meters with 7/8 stratocumulus improved to 1200 to 1500 meters (4000 to 5000 feet) by 1100 GMT. Scattered light rain showers were reported at the station and observed in the distance. Visibility was reported as 8.0 to 12.0 kilometers.

The radiosonde station at Schleswig was 103 kilometers west of the flight track center and located in an airflow that was parallel with the track.

The surface chart showed a 1026 millibar high centered in the northern part of the Irish Sea. There was generally high pressure over all of Europe with a weak gradient. At 500 millibars there was a low over the North Sea with a trough southward to Italy. The low center was five degrees west of the track. The flow was from the south to southwest and the air mass was unstable maritime polar.

# FLIGHT NO. C-421

ROBBY

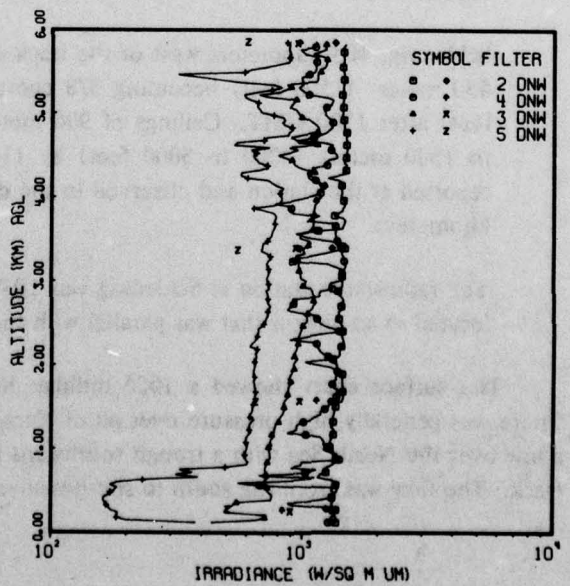
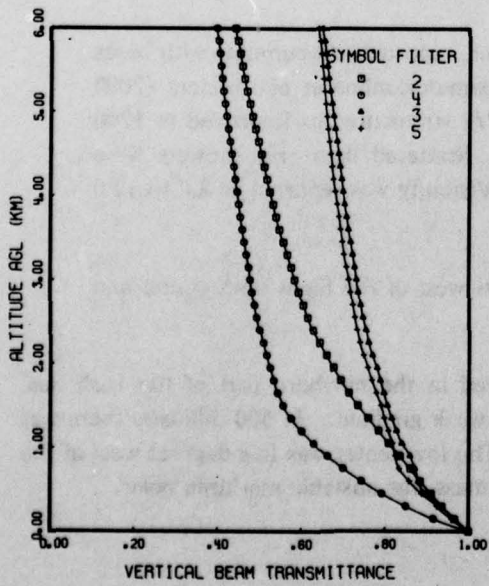
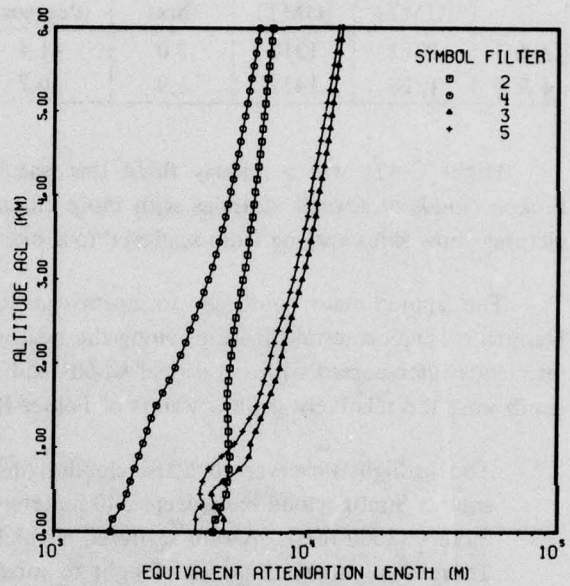
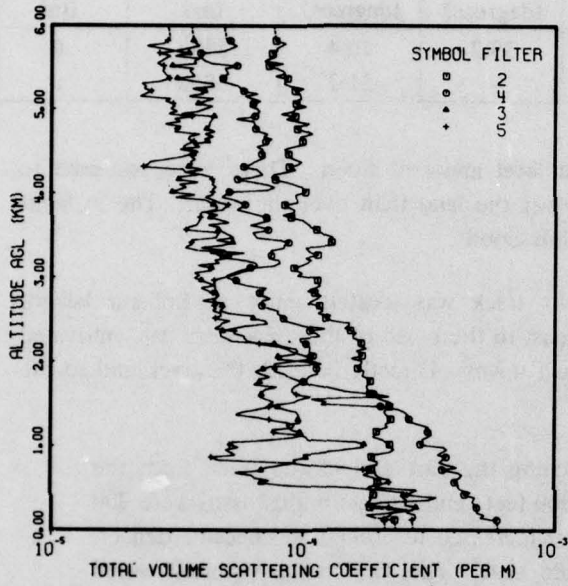

## FLIGHT NO. C-421 TOTAL VOLUME SCATTERING COEFFICIENT

(JOB 9505 DATE 06/15/78)  
 DATE 81077 FLIGHT NO. C-421 GROUND LEVEL ALTITUDE (M)= 0

ALTITUDE (M)	TOTAL VOLUME SCATTERING COEFFICIENT (PER M)			
	FILTERS	2	4	3
0	(2.35E-04 )	(5.97E-04 )	(2.13E-04 )	(2.75E-04 )
30	(2.33E-04 )	(5.94E-04 )	(2.12E-04 )	(2.73E-04 )
60	(2.33E-04 )	(5.93E-04 )	(2.12E-04 )	(2.73E-04 )
90	(2.32E-04 )	(5.91E-04 )	(2.11E-04 )	(2.72E-04 )
120	2.32E-04	5.90E-04	2.11E-04	2.71E-04
150	1.94E-04	5.06E-04	2.15E-04	2.81E-04
180	1.79E-04	5.25E-04	2.23E-04	2.79E-04
210	2.29E-04	4.90E-04	2.24E-04	2.60E-04
240	2.57E-04	4.93E-04	2.72E-04	2.59E-04
270	1.84E-04	4.88E-04	2.81E-04	2.20E-04
300	1.90E-04	4.82E-04	2.55E-04	1.77E-04
330	1.80E-04	4.72E-04	2.56E-04	2.05E-04
360	1.87E-04	4.74E-04	2.58E-04	3.15E-04
390	1.84E-04	4.80E-04	2.49E-04	3.38E-04
420	1.90E-04	4.36E-04	2.51E-04	2.59E-04
450	1.91E-04	4.62E-04	2.52E-04	2.69E-04
480	1.91E-04	4.27E-04	2.07E-04	2.84E-04
510	1.83E-04	4.18E-04	1.52E-04	1.97E-04
540	1.98E-04	4.18E-04	8.72E-05	1.98E-04
570	1.99E-04	4.03E-04	6.87E-05	2.22E-04
600	2.01E-04	4.11E-04	7.38E-05	2.19E-04
630	1.91E-04	4.23E-04	6.45E-05	2.02E-04
660	1.75E-04	4.31E-04	6.30E-05	1.97E-04
690	1.86E-04	4.13E-04	5.44E-05	1.95E-04
720	1.89E-04	3.59E-04	6.87E-05	1.75E-04
750	1.79E-04	4.12E-04	7.17E-05	1.45E-04
780	1.98E-04	3.74E-04	8.10E-05	1.06E-04
810	1.99E-04	3.50E-04	9.38E-05	9.05E-05
840	1.86E-04	3.61E-04	9.24E-05	4.61E-05
870	1.88E-04	3.73E-04	1.03E-04	4.35E-05
900	1.95E-04	3.45E-04	1.01E-04	5.41E-05
930	2.23E-04	3.60E-04	1.23E-04	5.19E-05
960	2.32E-04	3.76E-04	1.49E-04	4.96E-05
990	2.24E-04	3.62E-04	1.75E-04	5.58E-05
1020	2.23E-04	2.94E-04	1.76E-04	5.17E-05
1050	2.15E-04	3.02E-04	1.63E-04	5.29E-05
1080	2.07E-04	3.01E-04	1.06E-04	7.28E-05
1110	1.91E-04	3.13E-04	1.04E-04	9.16E-05
1140	1.95E-04	3.26E-04	9.82E-05	1.01E-04
1170	1.97E-04	3.15E-04	9.77E-05	7.69E-05
1200	2.04E-04	3.10E-04	9.05E-05	7.60E-05
1230	2.18E-04	3.15E-04	8.87E-05	9.15E-05
1260	2.13E-04	2.91E-04	8.66E-05	9.25E-05
1290	2.22E-04	2.68E-04	9.79E-05	8.63E-05
1320	2.24E-04	2.65E-04	9.62E-05	7.37E-05
1350	2.19E-04	2.60E-04	9.62E-05	6.53E-05
1380	2.14E-04	2.62E-04	9.62E-05	5.44E-05
1410	2.11E-04	2.52E-04	9.44E-05	5.77E-05
1440	2.14E-04	2.39E-04	8.56E-05	6.55E-05
1470	2.21E-04	2.04E-04	7.99E-05	7.36E-05
1500	2.29E-04	1.18E-04	7.46E-05	8.03E-05

**FLIGHT NO. C-421**  
**TOTAL VOLUME SCATTERING COEFFICIENT**

(JOB 9505 DATE 06/15/78)  
 DATE 81077 FLIGHT NO. C-421 GROUND LEVEL ALTITUDE (M)= 0

ALTITUDE (M)	FILTERS	TOTAL VOLUME SCATTERING COEFFICIENT (PER M)			
		2	4	3	5
1530	2.18E-04	1.24E-04	7.64E-05	9.29E-05	
1560	2.02E-04	1.09E-04	7.20E-05	9.73E-05	
1590	1.94E-04	2.20E-04	6.77E-05	1.08E-04	
1620	1.85E-04	1.92E-04	6.86E-05	9.46E-05	
1650	1.83E-04	1.48E-04	5.96E-05	9.10E-05	
1680	1.81E-04	1.33E-04	7.08E-05	9.10E-05	
1710	1.79E-04	1.20E-04	7.88E-05	9.24E-05	
1740	1.82E-04	1.06E-04	6.40E-05	9.63E-05	
1770	1.85E-04	1.01E-04	5.75E-05	1.00E-04	
1800	1.83E-04	1.04E-04	6.86E-05	9.33E-05	
1830	1.72E-04	1.06E-04	7.39E-05	8.75E-05	
1860	1.74E-04	1.14E-04	6.85E-05	8.48E-05	
1890	1.75E-04	1.14E-04	5.48E-05	7.87E-05	
1920	1.65E-04	1.14E-04	6.94E-05	7.75E-05	
1950	1.68E-04	1.13E-04	7.41E-05	7.73E-05	
1980	1.71E-04	1.13E-04	1.19E-04	7.72E-05	
2010	1.71E-04	1.04E-04	1.07E-04	8.76E-05	
2040	1.56E-04	1.09E-04	7.95E-05	1.07E-04	
2070	1.72E-04	1.10E-04	7.97E-05	1.05E-04	
2100	1.69E-04	1.08E-04	9.27E-05	9.64E-05	
2130	1.64E-04	1.06E-04	9.53E-05	9.02E-05	
2160	1.79E-04	1.06E-04	9.38E-05	8.67E-05	
2170	1.68E-04	1.06E-04	8.28E-05	8.05E-05	
2220	1.70E-04	1.03E-04	7.71E-05	6.72E-05	
2250	1.69E-04	9.82E-05	5.21E-05	6.02E-05	
2280	1.59E-04	9.75E-05	4.96E-05	5.86E-05	
2310	1.58E-04	1.17E-04	4.71E-05	5.86E-05	
2340	1.62E-04	1.12E-04	4.71E-05	5.34E-05	
2370	1.54E-04	1.06E-04	4.79E-05	5.35E-05	
2400	1.46E-04	1.22E-04	5.35E-05	4.47E-05	
2430	1.52E-04	1.01E-04	5.90E-05	4.69E-05	
2460	1.52E-04	9.31E-05	7.23E-05	4.76E-05	
2490	1.29E-04	8.55E-05	7.07E-05	5.11E-05	
2520	1.23E-04	8.35E-05	6.34E-05	4.48E-05	
2550	1.29E-04	8.19E-05	6.35E-05	4.73E-05	
2580	1.15E-04	7.91E-05	5.07E-05	4.71E-05	
2610	1.20E-04	7.99E-05	4.67E-05	4.39E-05	
2640	1.17E-04	7.34E-05	4.79E-05	4.52E-05	
2670	1.16E-04	6.85E-05	4.79E-05	4.44E-05	
2700	1.04E-04	6.86E-05	4.80E-05	4.61E-05	
2730	1.10E-04	6.87E-05	3.99E-05	4.42E-05	
2760	1.14E-04	7.39E-05	4.52E-05	4.51E-05	
2790	1.18E-04	6.90E-05	4.63E-05	4.58E-05	
2820	1.11E-04	6.71E-05	4.49E-05	4.37E-05	
2850	1.04E-04	6.92E-05	4.47E-05	4.17E-05	
2880	1.12E-04	7.13E-05	4.46E-05	3.94E-05	
2910	1.17E-04	6.00E-05	4.48E-05	4.43E-05	
2940	1.14E-04	5.46E-05	4.18E-05	4.45E-05	
2970	1.14E-04	5.40E-05	3.94E-05	4.42E-05	
3000	1.14E-04	5.01E-05	3.70E-05	4.78E-05	

**FLIGHT NO. C-421**  
**TOTAL VOLUME SCATTERING COEFFICIENT**

(JOB 9505 DATE 06/15/78)  
 DATE 81077 FLIGHT NO. C-421 GROUND LEVEL ALTITUDE (M)= 0

ALTITUDE (M)	TOTAL VOLUME SCATTERING COEFFICIENT (PER M)				
	FILTERS	2	4	3	5
3030		9.47E-05	4.99E-05	3.88E-05	5.17E-05
3060		9.90E-05	5.31E-05	3.71E-05	5.59E-05
3090		9.39E-05	5.63E-05	4.32E-05	6.01E-05
3120		9.17E-05	6.15E-05	4.32E-05	6.28E-05
3150		9.85E-05	7.69E-05	3.83E-05	6.56E-05
3180		1.03E-04	8.06E-05	4.64E-05	6.46E-05
3210		1.08E-04	8.00E-05	4.44E-05	5.89E-05
3240		1.02E-04	7.29E-05	4.99E-05	4.97E-05
3270		1.14E-04	7.46E-05	5.05E-05	4.68E-05
3300		1.07E-04	7.50E-05	4.27E-05	5.81E-05
3330		1.04E-04	7.44E-05	4.87E-05	3.80E-05
3360		1.02E-04	8.38E-05	3.94E-05	3.39E-05
3390		1.32E-04	8.37E-05	4.77E-05	3.56E-05
3420		1.29E-04	8.74E-05	5.23E-05	3.60E-05
3450		1.27E-04	8.11E-05	4.52E-05	3.64E-05
3480		1.31E-04	6.51E-05	5.27E-05	4.49E-05
3510		1.21E-04	6.41E-05	5.05E-05	4.56E-05
3540		1.17E-04	6.30E-05	4.82E-05	4.62E-05
3570		1.13E-04	7.24E-05	4.59E-05	3.42E-05
3600		1.07E-04	6.90E-05	4.57E-05	3.50E-05
3630		1.05E-04	6.15E-05	4.20E-05	3.77E-05
3660		1.02E-04	6.74E-05	5.04E-05	3.82E-05
3690		9.90E-05	7.35E-05	4.65E-05	3.87E-05
3720		8.92E-05	7.12E-05	4.26E-05	3.89E-05
3750		8.27E-05	6.58E-05	4.57E-05	3.91E-05
3780		9.22E-05	6.04E-05	4.11E-05	3.97E-05
3810		9.25E-05	5.47E-05	4.49E-05	4.81E-05
3840		8.80E-05	5.68E-05	4.57E-05	4.92E-05
3870		8.45E-05	5.89E-05	4.41E-05	5.04E-05
3900		9.51E-05	5.60E-05	4.25E-05	4.60E-05
3930		9.46E-05	5.28E-05	4.09E-05	4.38E-05
3960		9.42E-05	4.78E-05	3.13E-05	4.12E-05
3990		9.37E-05	4.95E-05	3.73E-05	4.41E-05
4020		1.03E-04	5.12E-05	3.04E-05	4.40E-05
4050		1.02E-04	7.30E-05	3.25E-05	4.39E-05
4080		9.98E-05	7.73E-05	3.45E-05	4.54E-05
4110		9.31E-05	7.25E-05	3.25E-05	4.37E-05
4140		8.65E-05	6.41E-05	3.83E-05	4.45E-05
4170		7.78E-05	5.50E-05	3.22E-05	4.37E-05
4200		7.51E-05	6.33E-05	3.29E-05	4.29E-05
4230		7.70E-05	6.93E-05	3.83E-05	3.97E-05
4260		8.53E-05	6.74E-05	3.50E-05	3.41E-05
4290		9.37E-05	6.55E-05	4.00E-05	3.35E-05
4320		8.82E-05	5.82E-05	3.52E-05	2.33E-05
4350		9.58E-05	6.22E-05	3.64E-05	2.43E-05
4380		9.91E-05	6.41E-05	3.58E-05	2.50E-05
4410		9.25E-05	6.75E-05	3.74E-05	2.89E-05
4440		8.86E-05	7.09E-05	3.59E-05	3.31E-05
4470		8.76E-05	6.86E-05	3.67E-05	3.65E-05
4500		8.72E-05	6.89E-05	3.74E-05	3.84E-05

## FLIGHT NO. C-421 TOTAL VOLUME SCATTERING COEFFICIENT

(JOB 9505 DATE 06/15/78)  
DATE 81077 FLIGHT NO. C-421 GROUND LEVEL ALTITUDE (M)= 0

ALTITUDE (M)	TOTAL VOLUME SCATTERING COEFFICIENT (PER M)				
	FILTERS	2	4	3	5
4530		8.46E-05	6.94E-05	3.25E-05	3.43E-05
4560		9.11E-05	6.56E-05	3.88E-05	3.35E-05
4590		1.01E-04	7.11E-05	3.69E-05	3.49E-05
4620		9.96E-05	7.11E-05	4.18E-05	3.68E-05
4650		1.00E-04	7.53E-05	4.07E-05	3.51E-05
4680		9.77E-05	6.98E-05	4.41E-05	3.55E-05
4710		1.09E-04	7.23E-05	4.09E-05	3.89E-05
4740		1.04E-04	6.72E-05	4.47E-05	3.10E-05
4770		9.47E-05	6.48E-05	4.14E-05	3.17E-05
4800		9.37E-05	6.45E-05	4.24E-05	3.25E-05
4830		1.06E-04	6.42E-05	4.25E-05	2.85E-05
4860		9.55E-05	6.37E-05	4.30E-05	3.25E-05
4890		8.56E-05	5.44E-05	4.37E-05	3.10E-05
4920		9.31E-05	6.45E-05	4.44E-05	3.62E-05
4950		8.18E-05	6.58E-05	3.30E-05	2.93E-05
4980		9.17E-05	6.72E-05	3.84E-05	3.16E-05
5010		9.26E-05	6.57E-05	4.11E-05	2.98E-05
5040		1.03E-04	6.14E-05	4.37E-05	3.10E-05
5070		9.36E-05	6.33E-05	3.83E-05	3.05E-05
5100		9.27E-05	6.74E-05	4.11E-05	2.84E-05
5130		9.80E-05	6.30E-05	4.38E-05	2.98E-05
5160		9.73E-05	5.88E-05	3.53E-05	2.27E-05
5190		9.69E-05	6.59E-05	4.00E-05	2.39E-05
5220		9.29E-05	5.80E-05	4.07E-05	2.50E-05
5250		1.00E-04	5.65E-05	3.65E-05	2.34E-05
5280		8.89E-05	5.60E-05	4.42E-05	2.38E-05
5310		8.38E-05	5.10E-05	4.38E-05	2.29E-05
5340		8.52E-05	4.68E-05	3.65E-05	2.74E-05
5370		8.66E-05	4.80E-05	3.16E-05	2.04E-05
5400		7.75E-05	4.91E-05	3.70E-05	2.88E-05
5430		8.47E-05	5.03E-05	3.62E-05	2.83E-05
5460		8.29E-05	4.94E-05	3.54E-05	2.77E-05
5490		7.86E-05	4.89E-05	3.66E-05	2.81E-05
5520		7.28E-05	5.46E-05	3.02E-05	2.79E-05
5550		8.28E-05	4.32E-05	3.75E-05	2.63E-05
5580		7.01E-05	4.06E-05	3.70E-05	2.74E-05
5610		7.39E-05	3.95E-05	3.88E-05	2.85E-05
5640		7.78E-05	3.87E-05	3.10E-05	2.97E-05
5670		7.52E-05	3.91E-05	3.51E-05	2.69E-05
5700		7.84E-05	4.88E-05	3.10E-05	3.08E-05
5730		7.82E-05	5.16E-05	3.49E-05	2.74E-05
5760		8.15E-05	5.44E-05	3.87E-05	2.39E-05
5790		8.49E-05	5.14E-05	3.73E-05	2.81E-05
5820		7.76E-05	5.11E-05	3.66E-05	2.89E-05
5850	(7.73E-05 )	4.92E-05	(3.65E-05 )	2.95E-05	
5880	(7.71E-05 )	(4.90E-05 )	(3.64E-05 )	(2.94E-05 )	
5910	(7.68E-05 )	(4.88E-05 )	(3.62E-05 )	(2.93E-05 )	
5940	(7.66E-05 )	(4.87E-05 )	(3.61E-05 )	(2.92E-05 )	
5970	(7.63E-05 )	(4.85E-05 )	(3.60E-05 )	(2.91E-05 )	
6000	(7.61E-05 )	(4.84E-05 )	(3.59E-05 )	(2.90E-05 )	
FIRST DATA ALT	120	120	120	120	
LAST DATA ALT	5820	5850	5820	5850	

## FLIGHT NO. C-421 EQUIVALENT ATTENUATION LENGTH

(JOB 9505 DATE 06/15/78)  
DATE 81077 FLIGHT NO. C-421 GROUND LEVEL ALTITUDE (M)= 0

ALTITUDE (M)	EQUIVALENT ATTENUATION LENGTH (M)			
	FILTERS 2	4	3	5
0	4.26E 03	1.67E 03	4.69E 03	3.64E 03
300	4.57E 03	1.85E 03	4.36E 03	3.83E 03
600	4.90E 03	2.03E 03	4.72E 03	3.92E 03
900	5.02E 03	2.19E 03	5.98E 03	4.55E 03
1200	4.95E 03	2.35E 03	6.34E 03	5.63E 03
1500	4.87E 03	2.56E 03	6.93E 03	6.38E 03
1800	4.93E 03	2.87E 03	7.58E 03	6.82E 03
2100	5.05E 03	3.18E 03	8.01E 03	7.24E 03
2400	5.16E 03	3.46E 03	8.51E 03	7.73E 03
2700	5.36E 03	3.76E 03	9.02E 03	8.32E 03
3000	5.58E 03	4.07E 03	9.61E 03	8.89E 03
3300	5.81E 03	4.35E 03	1.01E 04	9.30E 03
3600	5.97E 03	4.61E 03	1.06E 04	9.82E 03
3900	6.18E 03	4.88E 03	1.11E 04	1.03E 04
4200	6.37E 03	5.14E 03	1.16E 04	1.07E 04
4500	6.56E 03	5.38E 03	1.20E 04	1.12E 04
4800	6.71E 03	5.60E 03	1.24E 04	1.16E 04
5100	6.86E 03	5.82E 03	1.28E 04	1.21E 04
5400	7.01E 03	6.04E 03	1.32E 04	1.26E 04
5700	7.18E 03	6.28E 03	1.35E 04	1.30E 04
6000	7.34E 03	6.50E 03	1.39E 04	1.34E 04

## FLIGHT NO. C-421 VERTICAL BEAM TRANSMITTANCE FROM GROUND TO ALTITUDE

ALTITUDE (M)	VERTICAL BEAM TRANSMITTANCE FROM GROUND TO ALTITUDE			
	FILTERS 2	4	3	5
0	1.00E 00	1.00E 00	1.00E 00	1.00E 00
300	9.37E-01	8.50E-01	9.33E-01	9.25E-01
600	8.85E-01	7.44E-01	8.81E-01	8.58E-01
900	8.36E-01	6.63E-01	8.60E-01	8.24E-01
1200	7.85E-01	6.01E-01	8.28E-01	8.08E-01
1500	7.35E-01	5.56E-01	8.05E-01	7.90E-01
1800	6.94E-01	5.34E-01	7.89E-01	7.68E-01
2100	6.60E-01	5.16E-01	7.69E-01	7.48E-01
2400	6.28E-01	5.00E-01	7.54E-01	7.33E-01
2700	6.04E-01	4.88E-01	7.41E-01	7.23E-01
3000	5.84E-01	4.78E-01	7.32E-01	7.13E-01
3300	5.67E-01	4.69E-01	7.22E-01	7.01E-01
3600	5.47E-01	4.58E-01	7.12E-01	6.93E-01
3900	5.32E-01	4.50E-01	7.03E-01	6.84E-01
4200	5.17E-01	4.42E-01	6.95E-01	6.75E-01
4500	5.04E-01	4.33E-01	6.88E-01	6.69E-01
4800	4.89E-01	4.24E-01	6.80E-01	6.62E-01
5100	4.76E-01	4.16E-01	6.71E-01	6.56E-01
5400	4.63E-01	4.09E-01	6.63E-01	6.51E-01
5700	4.52E-01	4.04E-01	6.56E-01	6.45E-01
6000	4.41E-01	3.98E-01	6.49E-01	6.40E-01

FLIGHT C-422 - 11 AUGUST 1977 - DESCRIPTION OF FLIGHT & WEATHER CHARACTERISTICS

Filter Ident	Data Interval			Solar Zenith Angle			Maximum Flight Altitude (m)	Average Terrain Elevation (m)
	Start (GMT)	End (GMT)	Elapsed (hrs)	Initial ST&LV (degrees)	Solar Transit (degrees)	Final V-PRO (degrees)		
2 & 3	0953	1040	0.8	42.9	-	40.2	1560	0
4 & 5	1044	1120	0.6	40.1	39.5	39.5	1560	0

Flight C-422 was a morning flight. The skies were overcast with low level clouds.

The approximate southeast to northwest Rodby track was located south of Lolland Island, Denmark. Typical terrain features along the nearby coast to the north of the track were flat, cultivated farmlands interspersed with occasional woods and small towns. Directly beneath the track and to the south were the relatively shallow waters of Femer Bay.

The in-flight observer reported overcast clouds with bases at 1800 meters (6000 feet) with light precipitation. Heavy haze was present at all flight altitudes. The slant range visibility varied from 3.5 miles at 300 meters (1000 feet) to 10 miles at 1500 meters (5000 feet).

Fehmarnbelt, 9 miles south of the track center point, reported overcast stratocumulus based at 300 meters (1000 feet) and 4.0 kilometers visibility with light fog at 0900 GMT improving to 10.0 kilometers at 1200 GMT.

Schleswig, 103 kilometers west of the track center point, reported 4/8 cumulus at 300 meters (1000 feet) decreasing to 2/8 with bases at 750 meters (2500 feet) by 1100 GMT. Stratocumulus with amounts varying from 4/8 to 3/8 were at 900 meters (3000 feet) and altostratus with 4/8 coverage at 3600 meters (12,000 feet) were also recorded. Visibility of 4.0 kilometers with light fog gradually improved to 10.0 kilometers.

The radiosonde station at Schleswig was 103 kilometers west of the flight track and located in an airflow that was parallel with the track.

The surface chart showed ridging from the North Pole southward through eastern Britain. Moist air at low levels was being advected from the North Sea. At 500 millibars there was a low centered near Frankfurt. The flow was southeasterly and the air mass was modified maritime polar.

# FLIGHT NO. C-422

RODBY

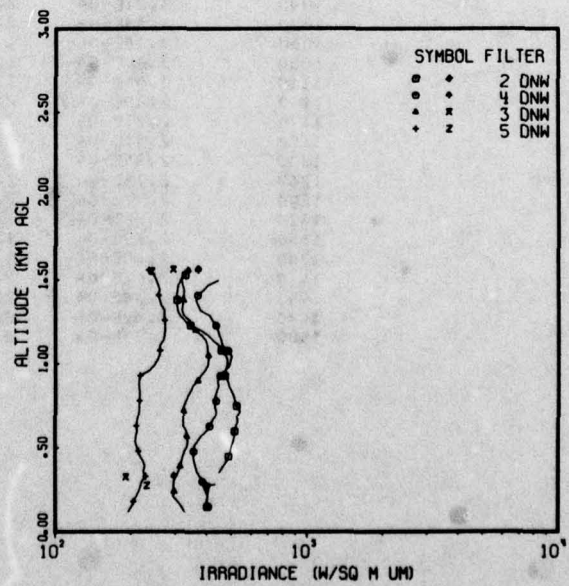
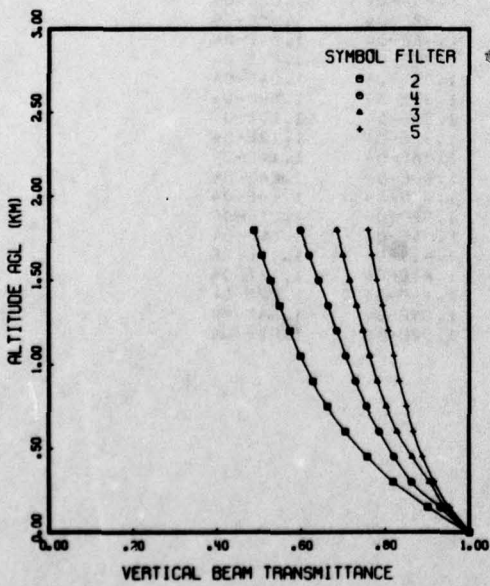
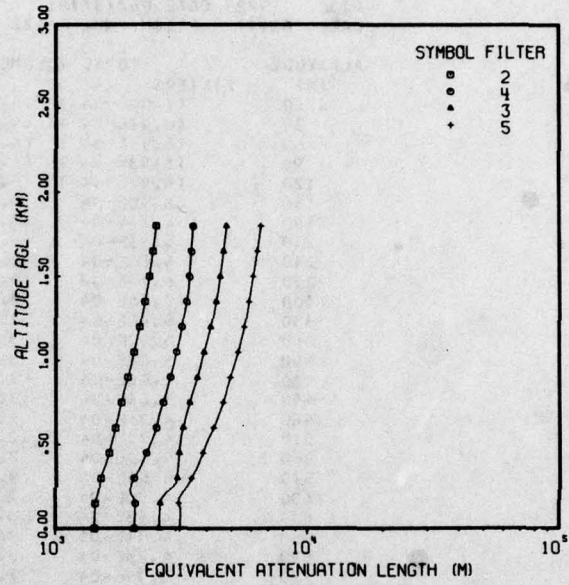
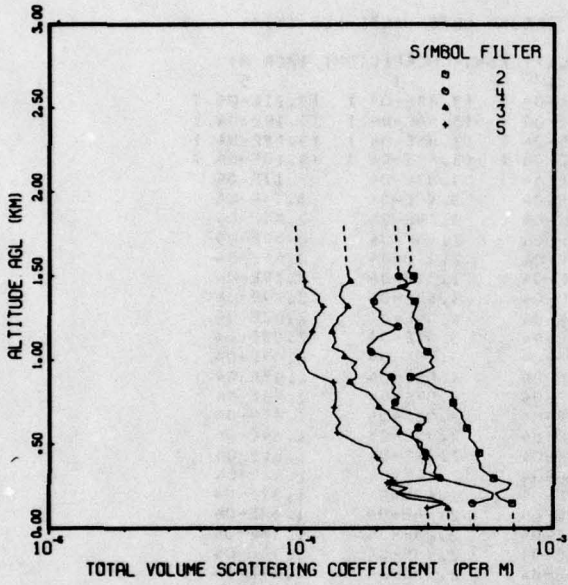

## FLIGHT NO. C-422 TOTAL VOLUME SCATTERING COEFFICIENT

(JOB 9723 DATE 06/13/78)  
DATE 81177 FLIGHT NO. C-422 GROUND LEVEL ALTITUDE (M)= 0

ALTITUDE (M)	TOTAL VOLUME SCATTERING COEFFICIENT (PER M)			
	FILTERS	2	4	3
0	(17.00E-04)	(4.85E-04)	(3.88E-04)	(3.21E-04)
30	(6.97E-04)	(4.83E-04)	(3.86E-04)	(3.19E-04)
60	(6.95E-04)	(4.81E-04)	(3.85E-04)	(3.18E-04)
90	(6.93E-04)	(4.80E-04)	(3.84E-04)	(3.18E-04)
120	(6.91E-04)	(4.79E-04)	3.83E-04	3.17E-04
150	6.90E-04	4.78E-04	3.72E-04	3.74E-04
180	6.14E-04	5.74E-04	3.28E-04	2.65E-04
210	5.91E-04	5.78E-04	2.46E-04	2.39E-04
240	6.66E-04	5.19E-04	2.21E-04	2.64E-04
270	6.73E-04	4.21E-04	2.31E-04	2.19E-04
300	5.75E-04	3.52E-04	3.53E-04	2.29E-04
330	5.40E-04	3.33E-04	3.04E-04	2.02E-04
360	5.07E-04	3.39E-04	3.07E-04	2.00E-04
390	5.08E-04	3.32E-04	3.10E-04	2.07E-04
420	4.96E-04	3.26E-04	3.08E-04	1.98E-04
450	5.04E-04	3.08E-04	3.05E-04	1.93E-04
480	4.94E-04	2.90E-04	2.98E-04	1.87E-04
510	4.79E-04	2.87E-04	2.99E-04	1.64E-04
540	4.60E-04	2.75E-04	2.74E-04	1.51E-04
570	4.65E-04	2.74E-04	2.44E-04	1.38E-04
600	4.50E-04	2.89E-04	2.47E-04	1.37E-04
630	4.43E-04	3.09E-04	2.36E-04	1.42E-04
660	4.31E-04	3.10E-04	2.23E-04	1.38E-04
690	4.28E-04	2.65E-04	2.19E-04	1.33E-04
720	4.04E-04	2.26E-04	2.02E-04	1.34E-04
750	3.98E-04	2.34E-04	1.98E-04	1.36E-04
780	3.96E-04	2.43E-04	1.91E-04	1.37E-04
810	3.95E-04	2.27E-04	1.84E-04	1.36E-04
840	3.39E-04	2.35E-04	1.63E-04	1.36E-04
870	3.16E-04	2.27E-04	1.55E-04	1.33E-04
900	2.69E-04	2.27E-04	1.64E-04	1.18E-04
930	3.04E-04	2.04E-04	1.64E-04	1.06E-04
960	3.34E-04	2.13E-04	1.58E-04	1.04E-04
990	3.21E-04	2.21E-04	1.65E-04	1.02E-04
1020	3.33E-04	2.21E-04	1.48E-04	9.65E-05
1050	3.14E-04	1.88E-04	1.46E-04	1.00E-04
1080	3.00E-04	1.82E-04	1.32E-04	1.02E-04
1110	2.93E-04	1.92E-04	1.36E-04	1.04E-04
1140	2.89E-04	2.00E-04	1.35E-04	1.08E-04
1170	2.85E-04	2.26E-04	1.32E-04	1.10E-04
1200	2.91E-04	2.41E-04	1.32E-04	1.12E-04
1230	2.85E-04	2.11E-04	1.38E-04	1.14E-04
1260	2.75E-04	2.02E-04	1.40E-04	1.14E-04
1290	2.77E-04	2.04E-04	1.47E-04	1.18E-04
1320	2.83E-04	1.90E-04	1.52E-04	1.21E-04
1350	2.79E-04	1.92E-04	1.46E-04	1.16E-04
1380	2.60E-04	1.94E-04	1.41E-04	1.17E-04
1410	2.67E-04	2.04E-04	1.42E-04	1.11E-04
1440	2.38E-04	2.60E-04	1.44E-04	1.02E-04
1470	2.82E-04	2.59E-04	1.55E-04	1.03E-04
1500	2.77E-04	2.41E-04	1.52E-04	1.01E-04

**FLIGHT NO. C-422**  
**TOTAL VOLUME SCATTERING COEFFICIENT**

(JOB 9723 DATE 06/13/78)  
 DATE 81177 FLIGHT NO. C-422 GROUND LEVEL ALTITUDE (M)= 0

ALTITUDE (M)	FILTERS	TOTAL VOLUME SCATTERING COEFFICIENT (PER M)			
		2	4	3	5
1530		2.63E-04	(2.40E-04 )	1.52E-04	1.01E-04
1560		2.70E-04	(2.40E-04 )	1.50E-04	9.62E-05
1590		(2.69E-04 )	(2.39E-04 )	(1.49E-04 )	(9.59E-05 )
1620		(2.68E-04 )	(2.38E-04 )	(1.49E-04 )	(9.56E-05 )
1650		(2.68E-04 )	(2.37E-04 )	(1.48E-04 )	(9.53E-05 )
1680		(2.67E-04 )	(2.37E-04 )	(1.48E-04 )	(9.51E-05 )
1710		(2.66E-04 )	(2.36E-04 )	(1.47E-04 )	(9.48E-05 )
1740		(2.65E-04 )	(2.35E-04 )	(1.47E-04 )	(9.45E-05 )
1770		(2.64E-04 )	(2.34E-04 )	(1.46E-04 )	(9.42E-05 )
1800		(2.63E-04 )	(2.34E-04 )	(1.46E-04 )	(9.39E-05 )
FIRST DATA ALT		150	150	120	120
LAST DATA ALT		1560	1500	1560	1560

**FLIGHT NO. C-422  
EQUIVALENT ATTENUATION LENGTH**

(JOB 9723 DATE 06/13/78)  
DATE 81177 FLIGHT NO. C-422 GROUND LEVEL ALTITUDE (M)= 0

ALTITUDE (M)	EQUIVALENT ATTENUATION LENGTH (M)			
	FILTERS 2	4	3	5
0	1.43E 03	2.06E 03	2.58E 03	3.12E 03
300	1.50E 03	2.04E 03	3.03E 03	3.44E 03
600	1.72E 03	2.50E 03	3.20E 03	4.23E 03
900	1.93E 03	2.85E 03	3.65E 03	4.93E 03
1200	2.15E 03	3.17E 03	4.13E 03	5.61E 03
1500	2.35E 03	3.39E 03	4.49E 03	6.06E 03
1800	2.50E 03	3.50E 03	4.75E 03	6.51E 03

**FLIGHT NO. C-422  
VERTICAL BEAM TRANSMITTANCE FROM GROUND TO ALTITUDE**

ALTITUDE (M)	VERTICAL BEAM TRANSMITTANCE FROM GROUND TO ALTITUDE			
	FILTERS 2	4	3	5
0	1.00E 00	1.00E 00	1.00E 00	1.00E 00
300	8.19E-01	8.63E-01	9.06E-01	9.16E-01
600	7.06E-01	7.87E-01	8.29E-01	8.68E-01
900	6.28E-01	7.29E-01	7.81E-01	8.33E-01
1200	5.73E-01	6.85E-01	7.48E-01	8.07E-01
1500	5.28E-01	6.42E-01	7.16E-01	7.81E-01
1800	4.87E-01	5.98E-01	6.85E-01	7.59E-01

## 8. DATA INTERPRETATION AND EVALUATION

### 8.1. METEOROLOGICAL DATA

The basic discussion of meteorological conditions, as presented in Section 6 and summarized with each flight description, is based upon meteorological data from a number of sources. There are hourly observations from two or more weather stations for every flight. There are in-flight observations by an on-board meteorologist. In addition, there are in-flight hemispherical pictures of the sky.

#### CLOUD CONDITIONS

The airborne pictures which documented the cloud conditions and the observations by an on-board meteorologist during each flight were described in Table 7.2.

The upper hemisphere photographs could not be readily separated into well defined cloud categories. This was in general due to the high degree of cloud variability as a function of time and altitude that occurred during most missions.

The flights have therefore been grouped into four very general classifications ranging from mostly clear to mostly overcast. The lower hemisphere photographs have been divided into two categories. These generalized categories are illustrated in Table 8.1.

#### TEMPERATURE

The temperature measurements were made using the AN/AMQ-17 aerograph set. The graphs of temperature in Fig. 6-2 indicate reasonable agreement between the airborne temperatures and the radiosonde temperatures in view of the spatial differences between the two measurements. On all the flights the RAOB launching was 73 to 208 kilometers from the flight track. Therefore the differences between these airborne and radiosonde temperatures may be due to local variations in terrain structure, etc. The RAOB temperatures were measured within  $\pm 4$  hours of the flight temperatures concurrent with Filter 4, except on July 4 when the RAOB was at midnight and the flight around noon.

For most of the flights the graphs in Fig. 6-2 show a relatively stable temperature function with altitude over the flight time interval. This is indicated by the general repeatability of the temperatures during each profile time interval. The minor exception is Flight C-420 where the temperatures are

**Table 8.1. Cloud Condition Summary**

Upper Hemisphere		Lower Hemisphere		Flights
Category	Description	Category	Description	
1	○ ⊙ Mostly clear to scattered	1	Haze, no clouds	C-411 (filters 2,3)
		2	Clouds	C-412
2	⊙ ⊙ Mostly scattered to broken	1	Haze, no clouds	C-419, C-420 (filters 4, 5)
		2	Clouds	C-411 (filters 4, 5), C-413 (filter 2) C-415 (filters 2, 3), C-416, C-418 (filter 2), C-421
3	⊙ ⊙ Mostly broken to overcast	1	Haze, no clouds	C-420 (filters 2, 3)
		2	Clouds	C-410, C-413 (filters 3, 4, 5) C-414, C-418 (filter 3)
4	⊙ Mostly overcast	1	Haze, no clouds	C-422 (filters 4, 5)
		2	Clouds	C-415 (filters 4, 5), C-418 (filters 4, 5), C-422 (filters 2, 3)

more variable with time in the altitude interval 0.6 to 1.1 kilometers. The data for the flight were taken in the order: Filter 2, Filter 3, Filter 4, then Filter 5. There is a slight temperature inversion during the Filter 2 profile which disappeared during the other profiles. This is the only temperature inversion measured during these 12 flights.

There were 12 project flights, listed in Table 7.3, accomplished between 4 July and 11 August 1977 at tracks from 48.02°N to 54.68°N latitude. Temperature data measured during these flights can be profitably compared to data from U.S. Standard Atmosphere Supplements (1966). To facilitate this comparison, the average temperature profile measured during each of the 12 flights has been superimposed on a graph of the July temperatures appropriate for 45° and 60°N latitudes in Figs. 8-1 and 8-2. The altitude scale in Figs. 8-1 and 8-2 is kilometers above mean sea level (MSL), and the ground elevations at the test sites range from 0 meters in Denmark to 46 meters in France.

The temperatures for the first three flights C-410 through C-412 are slightly above all the other temperature profiles. They were measured at the lowest latitude 48.02°N and generally lie on or near the 45°N curve at low altitude and between the 45°N and 60°N July curves at the higher altitudes. The other temperatures were measured for Tracks 52.9°N to 54.7°N. These temperatures cluster about the 60°N July curve except for flights C-413 and C-414, which temperatures are generally lower than the 60°N July temperature. All the temperatures are reasonable for these latitudes in July and August.

## RELATIVE HUMIDITY

Relative humidity was computed from the measured values of ambient temperature and dewpoint temperature. The dewpoint temperatures were measured using the modified Cambridge hygrometer

system [Duntley, *et al.* (1972c)] and are the fourth set of data reported since the modification was completed.

The graphs of relative humidity in Fig. 6-3 indicate that for five of the flights (C-413, C-414, C-415, C-416 and C-419) the airborne relative humidity values were markedly less than the RAOB relative humidities. For these flights the airborne measurements of dewpoint temperature were consistently less than the RAOB values. However, both the AN/AMQ-17 aerograph and the Cambridge hygrometer were apparently operating normally. It is therefore possible that these differences may be real differences due to the spatial and time differences between the two measurements. The attempt by the aircraft to select flight patterns between rather than through clouds, may contribute to these differences. The RAOB is released at a set time and place and may well encounter clouds in its ascent, accounting for relative humidities of 100% or near 100%. Some of these flights did indicate the presence of clouds below the highest flight altitude (Table 8.1, lower hemisphere category 2).

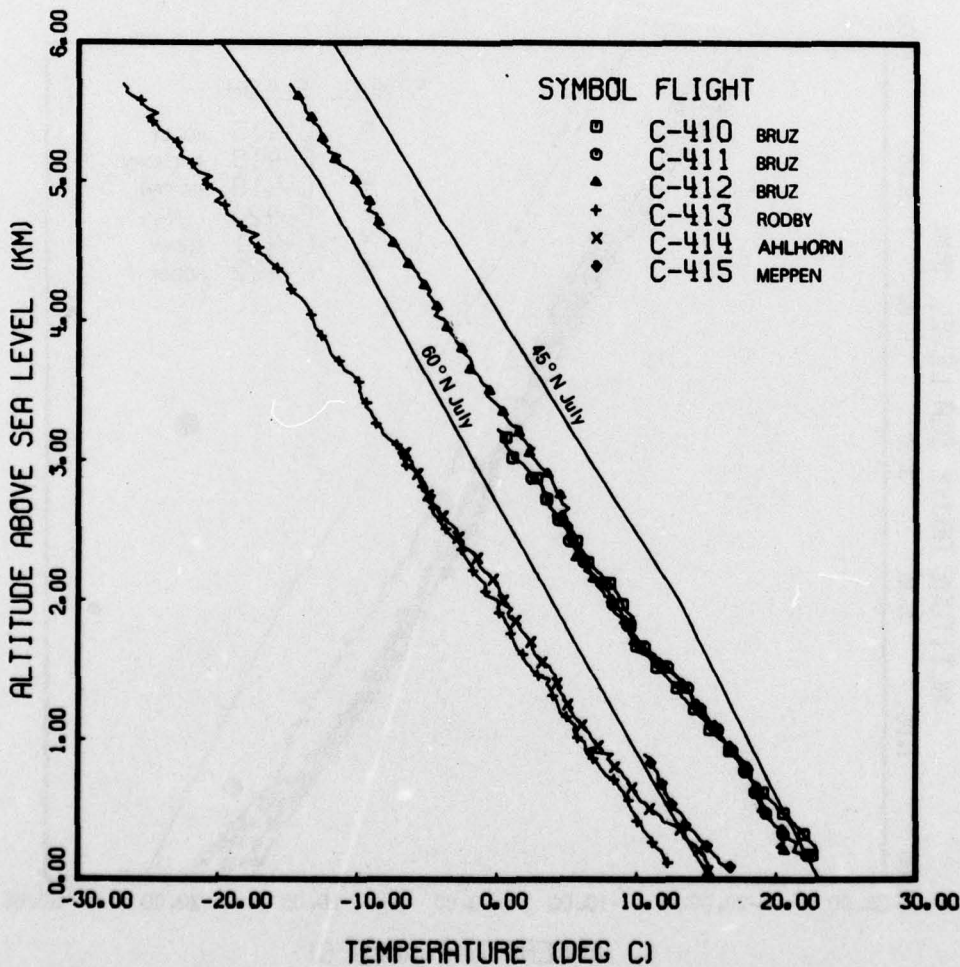

Fig. 8-1. Temperature for OPAQUE III Flights 4 to 29 July 1977, Latitudes 48.02°N to 54.68°N Compared to Temperature from U.S. Standard Atmosphere Supplements (1966).

The graphs in Fig. 6-3 indicate that relative humidity is fairly stable over the time interval of the flight for Flights C-414, C-418, C-419 and C-422. For the rest of the flights the general structure with altitude is usually repeated for the four profiles, but the range of values at any one altitude is often quite large.

The relationship of total volume scattering coefficient values and relative humidity will be dealt with in the next section.

## 8.2. AIRBORNE RADIOMETRIC DATA

### TOTAL VOLUME SCATTERING COEFFICIENT

The nephelometer was known to have stray light problems during the OPAQUE I and II deploy-

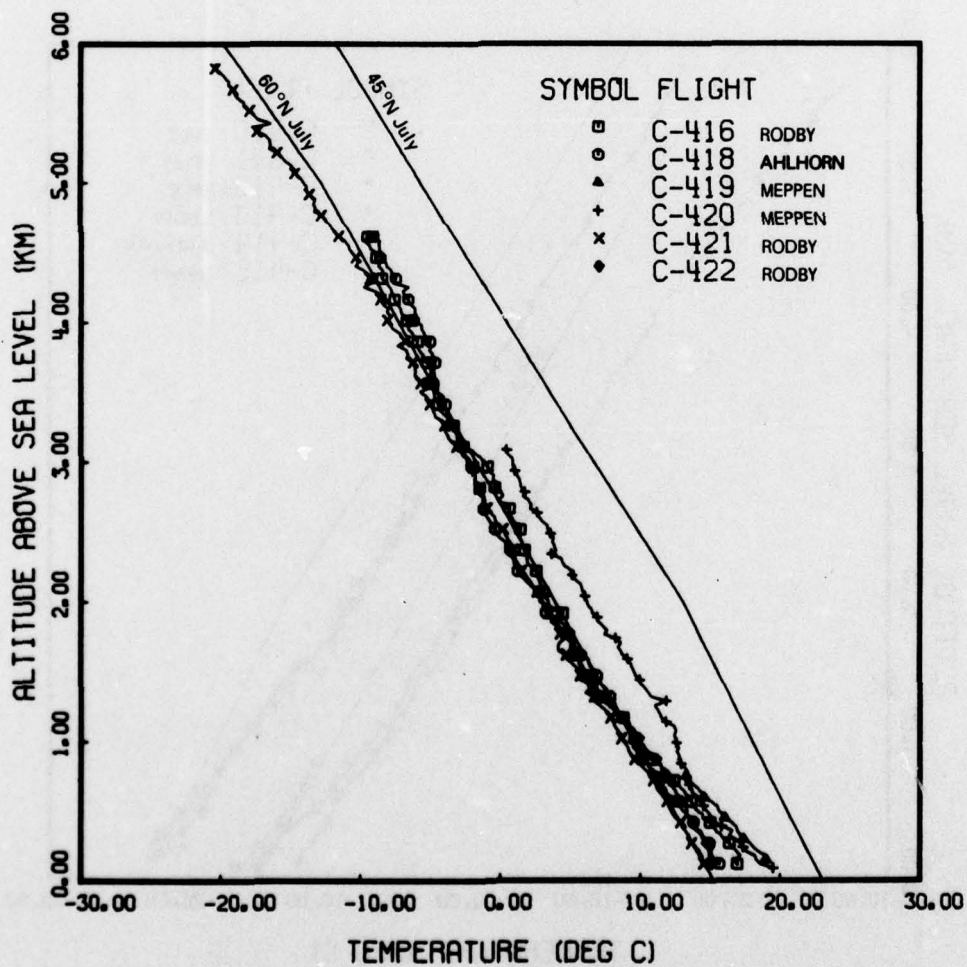

Fig. 8-2. Temperature for OPAQUE III Flights 1 to 11 August 1977, Latitudes 52.88°N to 54.68°N Compared to Temperatures from U.S. Standard Atmosphere Supplements (1966).

ments which affected both the total volume scattering coefficient measurement and the volume scattering function measurement at 150°. Prior to OPAQUE III, modifications were made to the design of the entrance to the primary light trap in an attempt to eliminate the problem. In order to determine if this modification eliminated the stray light errors, the OPAQUE III nephelometer data were subjected to the same analysis as the OPAQUE I and II data, see pages 8-5 through 8-12 of Duntley, *et al.* (1977) and pages 8-5 through 8-7 of Duntley, *et al.* (1978).

*Evidence of Stray Light in Total Volume Scattering Coefficient Data.* The graph of proportional volume scattering function at 30° and 150° and the ratio of the total to Rayleigh volume scattering coefficient  $s/Rs$  for the Pseudo-Photopic Filter 4 OPAQUE III data is given in Fig. 8-3. The curves are the median values derived from Barteneva (1960). We had found that the most recent historical data from deployments between 1970 and 1976 compared reasonably well to this Barteneva curve, see Fig. 8-3 of Duntley, *et al.* (1977). The OPAQUE III proportional volume scattering function data for 150° versus the total to Rayleigh volume scattering coefficient ratio is more similar to the Barteneva curve than were the OPAQUE I and II data, indicating that the bulk of the stray light error in the measurement of volume scattering function at 150° had indeed been corrected by the modifications. The graph of proportional volume scattering function data for 30° versus the total to Rayleigh ratio is, however, similar to that of the OPAQUE I and II data, see Fig. 8-4 of Duntley, *et al.* (1977) and Fig. 8-3 of Duntley, *et al.* (1978). This indicates that the stray light error in the measurement of total volume scattering coefficient had not yet been corrected.

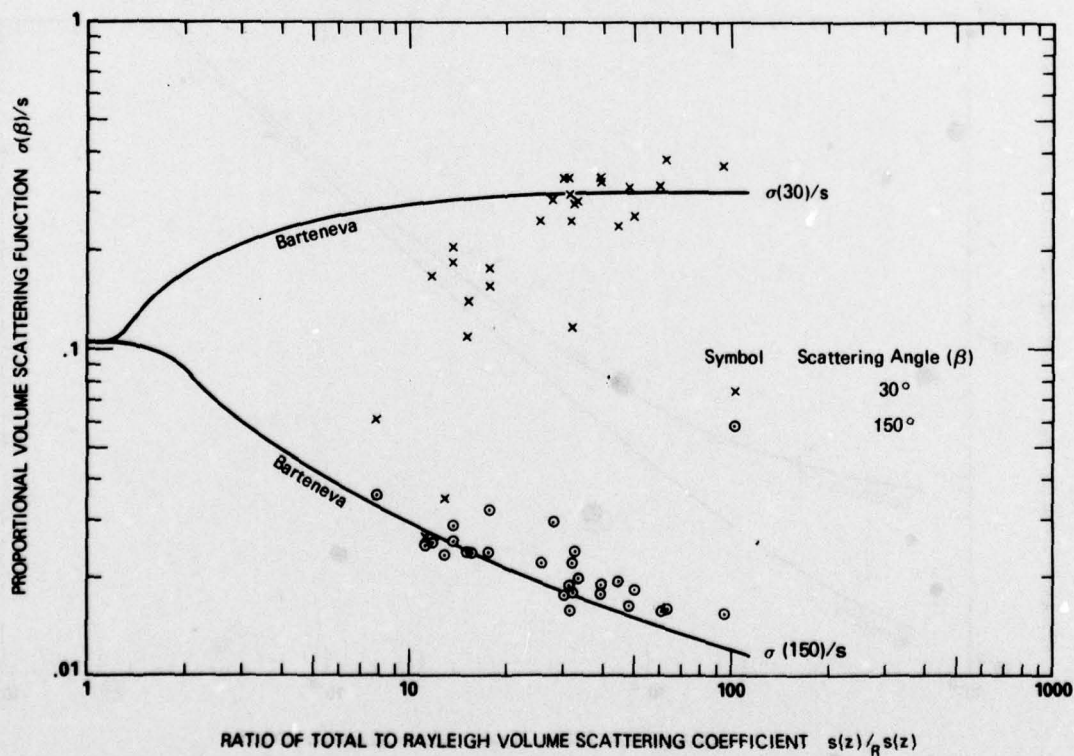

Fig. 8-3. Measured Proportional Volume Scattering Function Versus the Ratio of Total to Rayleigh Volume Scattering Coefficient for OPAQUE III Pseudo-Photopic Filter 4 Mean Wavelength 557 Nanometers.

The stray light error in the total volume scattering coefficient was corrected for the OPAQUE I and II data by subtracting out a constant error  $C$  which was separately determined for each filter. Fig. 8-4 is a graph of the measured total volume scattering coefficient versus the volume scattering function at  $30^\circ$  for the OPAQUE III pseudo-photopic Filter 4 data. The lower curve is again based upon the median values derived from Barteneva (1960). The upper curve is the Barteneva values if a constant error  $C$  is added to the total volume scattering coefficient for Barteneva. The constant  $C$  was derived from the OPAQUE I data. This graph indicates that the same error apparently applies to the OPAQUE III data. There is slightly more scatter, but the correction should be the same or less for OPAQUE III and the scatter is in the direction of a larger error which does not appear reasonable.

Similar graphs of the data for OPAQUE III were made for the other three filters. In all cases, the stray light error is similar to the OPAQUE I error. Therefore, the same corrections were applied to the OPAQUE III data as were applied to the OPAQUE I and II data. The measured total volume scattering coefficient was corrected by subtracting the OPAQUE I correction constants:  $2.99E-5$  for Filter 2 mean wavelength 478 nanometers,  $2.37E-5$  for Filter 4 mean wavelength 557 nanometers,  $1.79E-5$  for Filter 3 mean wavelength 664 nanometers, and  $1.40E-5$  for Filter 5 mean wavelength 765 nanometers. The total volume scattering coefficient data reported herein have been corrected by these constants.

Because the correction is a subtractive one, it should be noted that the scatter in the low magni-

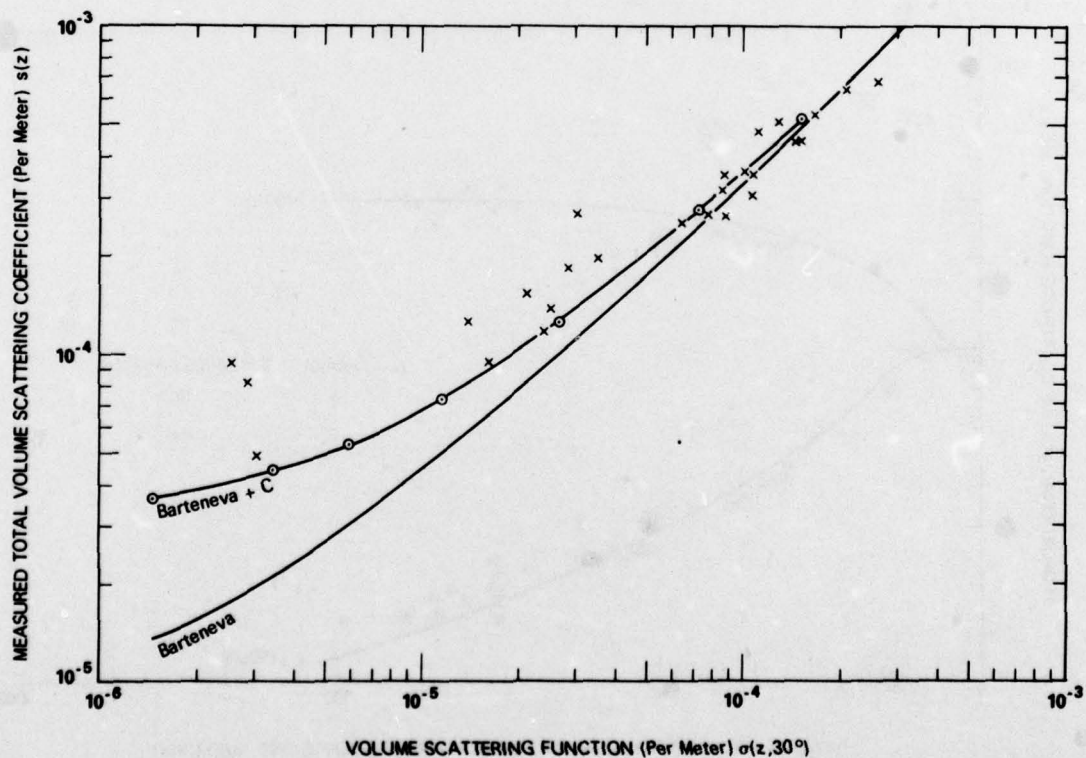

Fig. 8-4. Total Volume Scattering Coefficient Versus Volume Scattering Function at 30 Degrees for OPAQUE III Filter 4 Pseudo Photopic Mean Wavelength 557 Nanometers,  $C=2.37 \times 10^{-5}$ .

tude data has been magnified, whereas the variability of the high magnitude data has been affected very little.

*General Evaluation.* The data reported for total volume scattering coefficient were measured during the vertical profile flight elements. Since four different flight patterns were used during OPAQUE III, they are summarized in Table 8.2. The first pattern listed is a (2+4) profile, two filters at four straight and level altitudes, with the vertical profile during ascent for the first filter, and during descent in the second filter. This flight pattern was illustrated in Fig. 4-1. The maximum altitude varied with the flight pattern as noted in column 3, Table 8.2. The elapsed time also varied according to flight pattern and altitude interval and these averages are given in column 4.

The data have been extrapolated upward to the nearest 300-meter altitude increment. These upward extrapolations are based upon the density ratios of the U.S. Standard Atmosphere, 1962 (equivalent to the 45°N Spring/Fall). The extrapolations appear on the graphs of total volume scattering coefficient as a slightly slanting dashed line. The upward extrapolations generally follow the prevailing trend of the data, and are over small altitude intervals. However, the upward extrapolation for Flight C-411 Filters 3, 4 and 5, Flight C-413 Filter 4, and Flight C-414 Filter 5 should be used with caution since some of these data indicate the presence of a high altitude haze layer which was unstable with time and/or space.

For simultaneous data, the order of the scattering coefficient data by filter generally should be the inverse of the mean wavelength of the filters, i.e.,  $s(\text{filter } 2) > s(4) > s(3) > s(5)$ . Although the data were not simultaneous, the data above 3 kilometers on the high altitude flights except C-413 tend to follow this order. On the intermediate altitude flights (~3000m maximum altitude), there is a clear, stable area below 3km except for Flight C-411 and C-414 Filter 5.

To more easily compare the scattering characteristics of the flights, the Filter 4 (pseudo-photopic) total volume scattering coefficient profiles for each flight have been graphed in Figs. 8-5 and 8-6. Fig. 8-5 contains the flights made in July and Fig. 8-6, the flights made in August. In comparing the data for the two figures it should be noted that the total volume scattering coefficients are on a slightly different scale due to the difference in the range of values.

Table 8.2. Flight Patterns Used During OPAQUE III

Pattern	Description	Maximum Altitude	Average Elapsed Time		Flights
			Hours	Minutes	
2+4	Two filters at four straight and level altitudes	~5700 m	1	49	C-412, C-416, C-421
2+3	Two filters at three straight and level altitudes	~3000 m	1	18	C-410, C-411, C-420
2+2	Two filters at two straight and level altitudes	~1500 m		44	C-415, C-419, C-422
V-PRO	Partial or no straight and level altitudes	~5700 m		18	C-413, C-418
		~3000 m		14	C-414

Two flights stand out as different from all the rest. Flight C-413 has much lower values of total volume scattering coefficient and Flight C-418 much larger values of total volume scattering coefficient at the lower altitudes, 0 to 2 km, than the other 10 flights.

For OPAQUE I and OPAQUE II the high altitude data generally indicated a clear layer ( $s=1.2E-5$  to  $7E-5 \text{ m}^{-1}$ ) above 1.3 to 3 km. The OPAQUE III data show similarly clearer air above 3 km, although the flights made in August appear slightly hazier than those made in July, which relate more closely to the OPAQUE I and II flights. This general trend is illustrated in Table 8.3.

*Low Altitude Data.* The total volume scattering coefficient data below 1.5 kilometers tend to be more complex than the high altitude data. There are generally one or more haze layers in the region 0 to 1.5 kilometers and the relationship by filter is less regular than at high altitude, indicating a less

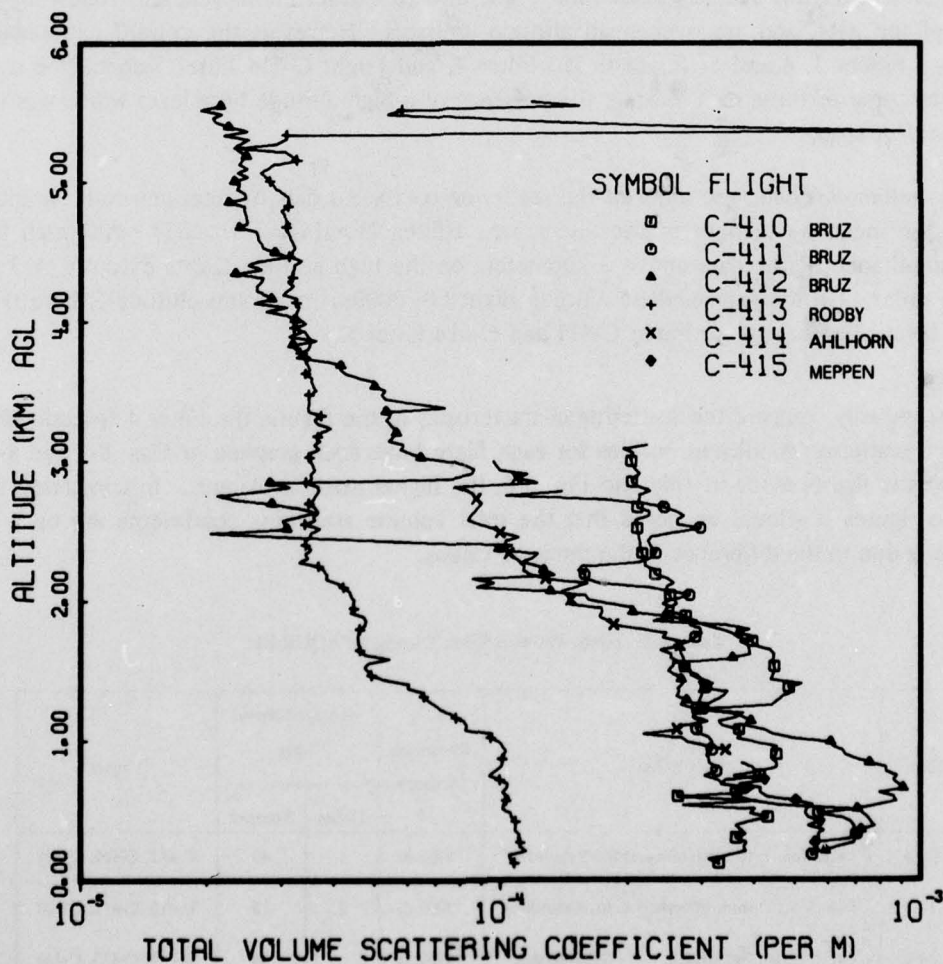
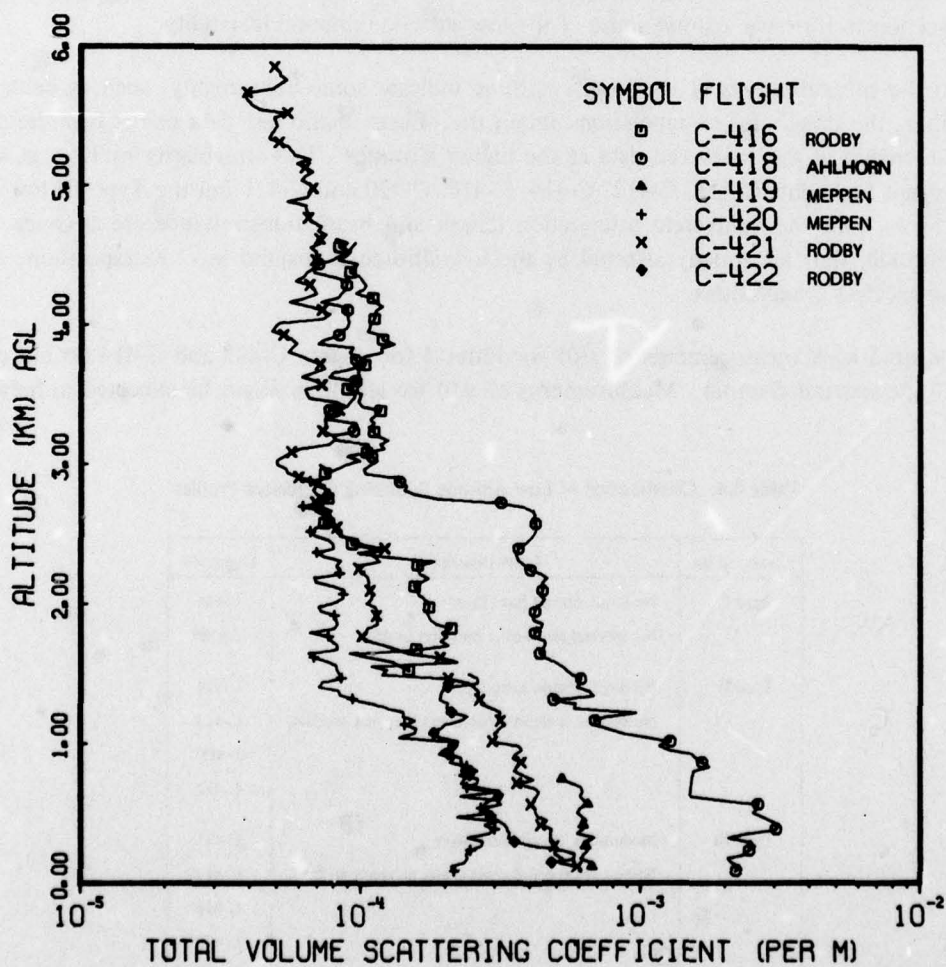

Fig. 8-5. Total Volume Scattering Coefficient for Filter 4 Pseudo-Photopic for six OPAQUE III Flights 4 through 29 July 1977.

**Table 8.3. Comparison of the OPAQUE III to the OPAQUE I and II Upper Level Scattering Coefficients**

Data Set	Range of Total Volume Scattering Coefficient Values	
	Minimum ( $m^{-1}$ )	Maximum ( $m^{-1}$ )
OPQ I & II	1.2E-5	7.0E-5
OPQ III Jul	2.0E-5	6.0E-5
OPQ III Aug	4.0E-5	1.2E-4



**Fig. 8-6. Total Volume Scattering Coefficient for Filter 4 Pseudo-Photopic for six OPAQUE III Flights I through 11 August 1977.**

stable aerosol. To illustrate the complexities of the low altitude data, the total volume scattering coefficients for the 0 to 1.5 kilometer altitude interval are replotted on an expanded scale for each of the twelve OPAQUE III flights. These are presented in Figs. 8-7 through 8-9. As one might expect, even though the variability within this group of twelve flights is broad, the flights can be separated into about three general classes. This general classification by type of profile is illustrated in Table 8.4.

This typical distribution of low altitude profile classifications becomes particularly significant whenever the data application involves lines of sight restricted to the low altitude regime. The erroneous assumption that the low level atmosphere is always a well behaved Type I environment may easily result in the computation of severely misleading values of beam and contrast transmittances.

Note that the graph for Filter 4 Flight C-410 Figure 8-7 indicates a double valued function of total volume scattering coefficient between 1 and 1.8 km. This region of overlapping values was measured during two V-PRO elements which were separated in time by about ten minutes. Whereas these overlapping values are averaged in the data displays of Section 7, they are allowed to retain their individuality in this section to further illustrate some of the low altitude temporal instability.

When the measurements at the lowest altitude indicate some abnormality, such as being out of order by filter, the downward extrapolations retain the offsets of the last data points regardless of the general relationship of the measured data at the higher altitudes. This irregularity by filter at low altitude is apparent in Flights C-411, C-412, C-414, C-418, C-420 and C-421 (all the Type III low altitude profiles). Since both the equivalent attenuation length and beam transmittance are between ground level and altitude, they are greatly affected by the low altitude to ground level extrapolation, and will reflect these spectral irregularities.

The ground level measurements of  $s(0)$  for Filter 4 for Flights C-412 and C-414 do not clear up the low altitude spectral disorder. Measurements of  $s(0)$  for all filters might be expected to help in this regard.

**Table 8.4.** Classification of Low Altitude Scattering Coefficient Profiles

Classification	Class Description	Flight No.
Type I	No large, abrupt haze layer	C-416
	No spectral cross-over between profiles	C-419*
Type II	No large, abrupt haze layer	C-410
	Numerous spectral cross-overs between profiles	C-413
		C-415*
		C-422
Type III	Moderately abrupt haze layer	C-411
	Numerous spectral cross-overs between profiles	C-412
		C-414
		C-418
		C-420
		C-421

\*Data limited to measurements below 870 m for C-415 and 750 m for C-419.

FLIGHT C-416  
Rodby  
Type I

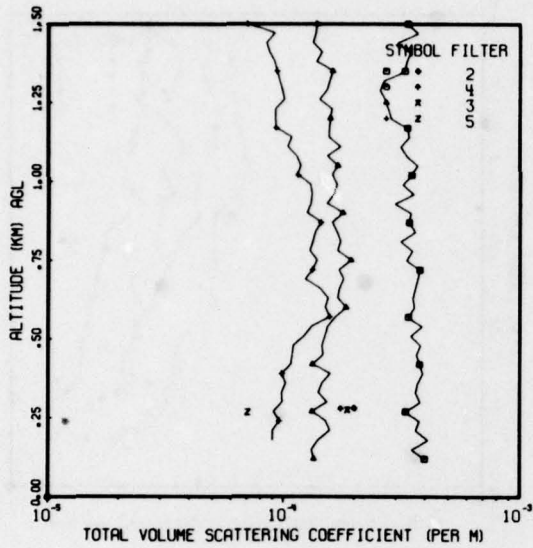

FLIGHT C-419  
Meppen  
Type I

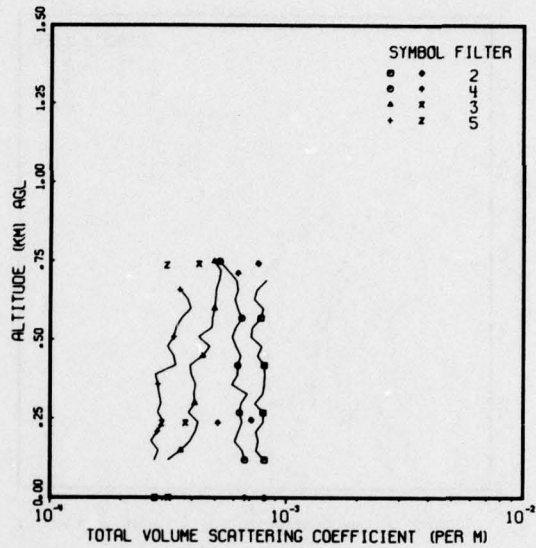

FLIGHT C-410  
Bruz  
Type II

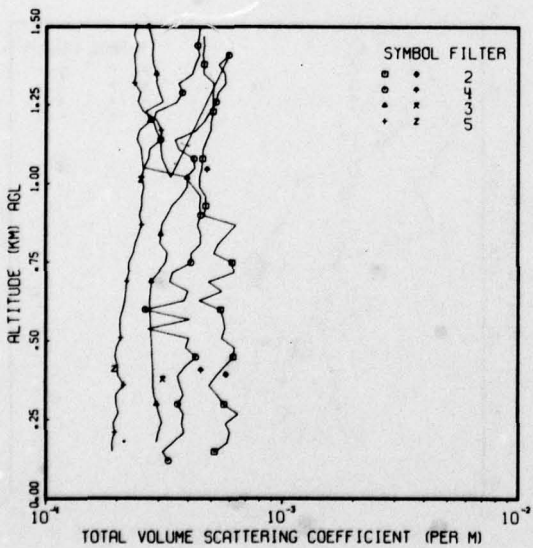

FLIGHT C-413  
Rodby  
Type II

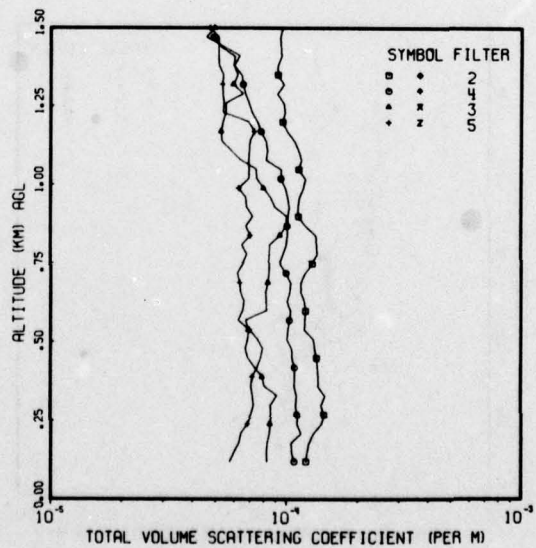
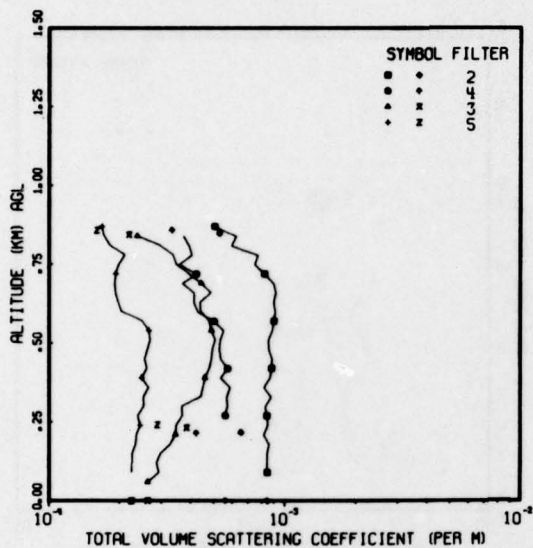
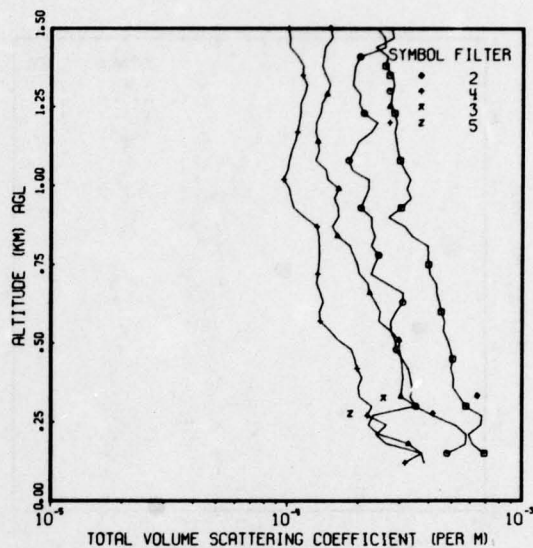

Fig. 8-7. Low altitude total volume scattering coefficients for Types I and II profiles.

FLIGHT C-415  
Meppen  
Type II



FLIGHT C-422  
Rodby  
Type II



FLIGHT C-411  
Bruz  
Type III

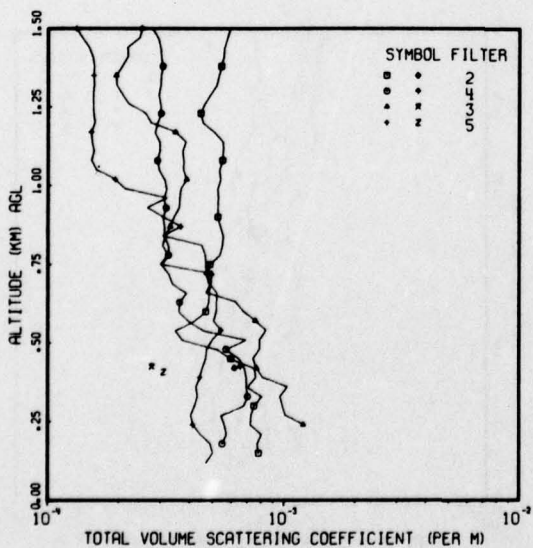

FLIGHT C-412  
Bruz  
Type III

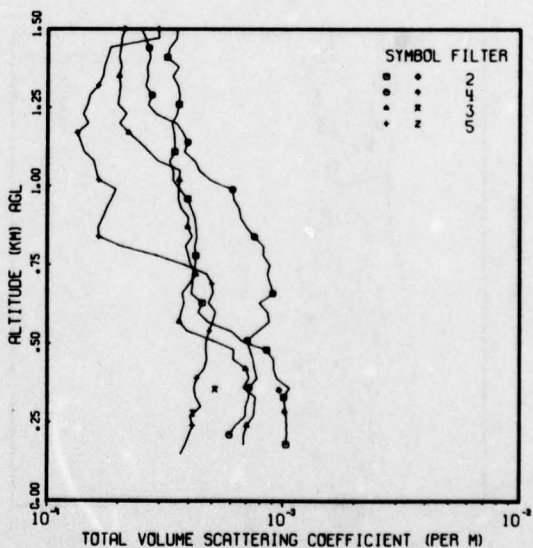
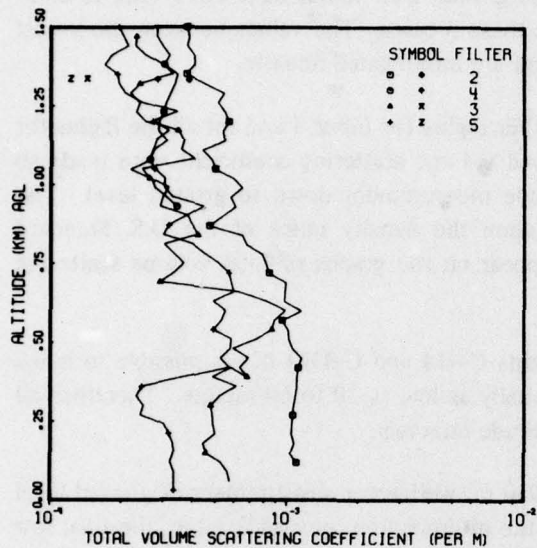
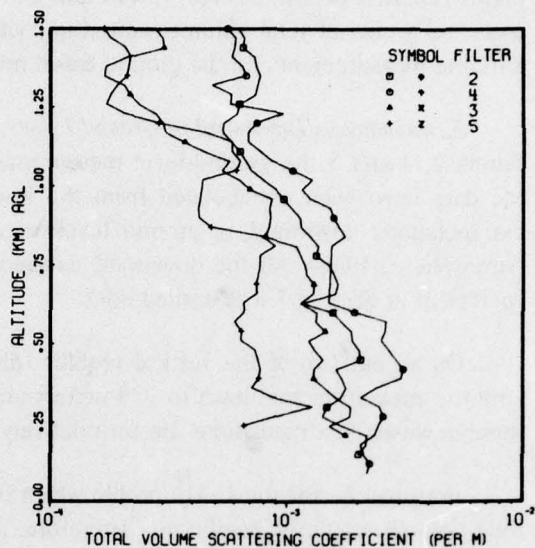

Fig. 8-8. Low altitude total volume scattering coefficients for Types II and III profiles.

**FLIGHT C-414**  
**Ahlhorn**  
**Type III**



**FLIGHT C-418**  
**Ahlhorn**  
**Type III**



**FLIGHT C-420**  
**Meppen**  
**Type III**

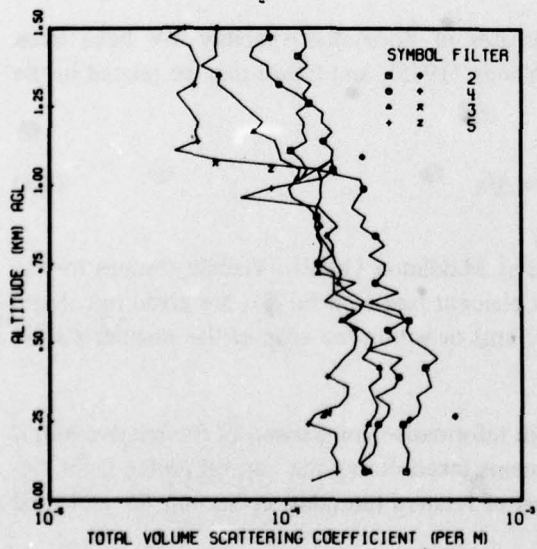

**FLIGHT C-421**  
**Rodby**  
**Type III**

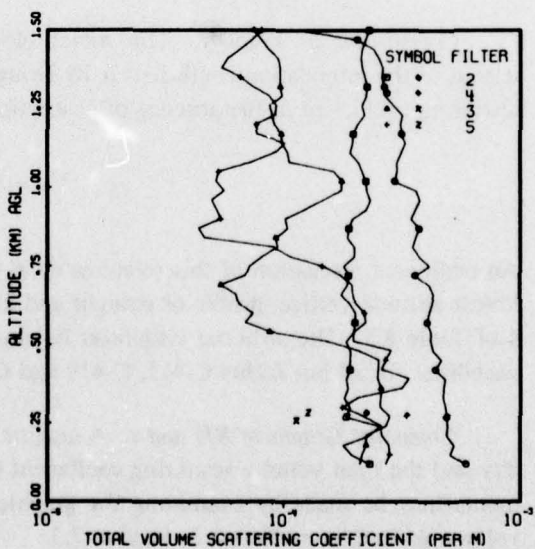

Fig. 8-9. Low altitude total volume scattering coefficients for Type III profiles.

*Ground Level Data.* Ground level measurements of total volume scattering coefficient for Filter 4 were made from 7 July to 3 August 1977 at Bruz, France and Meppen, Germany. Three of these data sets were both concurrent with (or reasonably close in time) and near the flight track of three of the 12 flights reported herein: C-412, C-414 and C-415. These ground data values have been used to complete the profile of total volume scattering coefficient in these 3 cases. The values between the lowest airborne measurement and the ground based measurement are interpolated linearly.

*Extrapolations Downward to Ground Level.* On all other flights for Filter 4 and for all the flights for Filters 2, 3 and 5, no ground-level measurements of total volume scattering coefficient were made so the data have been extrapolated from the lowest altitude measurement down to ground level. The extrapolations downward to ground level were based upon the density ratios of the U.S. Standard Atmosphere, 1962. All the downward extrapolations appear on the graphs of total volume scattering coefficient in Section 7-3 as dashed lines.

On all but two of the vertical profiles (filter 4 Flights C-414 and C-416) it was possible to make airborne measurements down to 270 meters and occasionally as low as 30 to 60 meters. Therefore all these downward extrapolations are for relatively small altitude intervals.

Fortunately, for the C-414 profile which ended at 930 m, we have a measurement of ground level total volume scattering coefficient. Therefore, although the interpolation interval is large, the final low altitude profile is based upon real data points at 930 and 0 m.

For C-416 the lowest profile data point for Filter 4 was at 1530 m but there was a straight and level measurement at 270 m, therefore the low altitude profile is based upon real data points at 1530 m and 270 m with values linearly interpolated between 1530 m and 270 m and extrapolated by the density ratio from 270 m to ground level.

*Comparison to Visibility.* The meteorological estimates of horizontal visibility  $VV$  have been related to the attenuation coefficient  $\alpha$  by Douglas and Young (1945), and hence may be related to the scattering coefficient in the absence of absorption by

$$VV = \ln 18/\alpha \approx 3/s . \quad (8.1)$$

An additional discussion of this relationship is presented by Middleton (1952). Visibility values for the lowest altitude vertical profile or straight and level flight element based on Eq. 8.1 are given in column 4 of Table 8.5. The airborne visibilities lie close to ( $\pm 2$  km) or within the span of the weather station visibilities for all but flights C-413, C-419 and C-421.

*Composite Graphs of RH and s.* A qualitative though informative comparison of the relative humidity and the total volume scattering coefficient measurements taken during the vertical profile flight elements may be made by examining the graphical displays of relative humidity in Section 6.1 and total volume scattering coefficient in Section 7.3.

A convenient method of assessing the degree of similarity, or the lack thereof, between the relative humidity profiles presented in Fig. 6-3 and the total volume scattering coefficient profiles presented in Section 7, is to use the composite plots illustrated in Fig. 8-10. In these automatically generated

**Table 8.5. Low Altitude Visibility Based on Nephelometer Compared to Meteorological Estimates from Weather Stations**

Track Location	Flight No.	Time (GMT)	Visibility (kilometers)						
			Airborne Nephelometer	Weather Stations					
				Rennes (7 km)	Nantes (78 km)	St. Nazaire (86 km)	Anbers (107 km)	Brest (208 km)	
Bruz	C-410	1309	9.1	11.2	11.2	11.2	20.0	11.2	
	C-411	1017	5.5	5.0	9.9	9.0	8.0	5.0	
	C-412	1056	5.2	7.0	8.0	9.0		9.0	
				Ahlhorn (26 km)	Meppen (40 km)	Oldenberg (40 km)	Lingen (54 km)	Eelde (89 km)	Twente (94 km)
Ahlhorn	C-414	1024	8.8*		7.0		10.0	12.0	8.0
	C-418	930	1.4	3.0	2.9	2.5	3.0	4.5-8.0	2.2-3.0
				Meppen (37 km)	Oldenberg (42 km)	Ahlhorn (43 km)	Lingen (57 km)	Eelde (71 km)	Twente (95 km)
Meppen	C-415	1044	5.4	7.0			10.0	30.0	9.0
	C-419	1538	4.5	11.2**	7.0	11.2	25.0	12.0	8.0
	C-420	1015	14.0	11.2	11.2	11.2	25.0	20.0	25.0
				Fehmarnbelt (9 km)	Kegnaes (76 km)	Mon (95 km)	Schleswig (103 km)		
Rodby	C-413	1458	28.0	20.0	17.0	15.0			
	C-416	1319	17.0	20.0	20.0	18.0	25.0		
	C-421	1233	5.1	10.0			10.0		
	C-422	1054	6.3	4.0			8.0		

\*930 m altitude data at 1344 GMT \*\*Data at 1344 GMT

overlays one can readily determine the degree to which the two plots exhibit the same or similar structural characteristics. These paired plots of simultaneously recorded data sets represent an optional display form recently automated and should prove useful in guiding the analyst toward the goal of determining a more clearly defined relationship between the measured optical and meteorological properties of the atmosphere. It is anticipated that the increased use of these displays will accelerate our ability to select flights whose optical and meteorological characteristics are thoroughly enough documented to enable their use in firmly establishing their linking relationships.

The examples shown in Fig. 8-10 were selected from twelve pairs of profile data measured during the OPAQUE III Filter 4 pseudo-photopic ascents. These graphs were chosen to illustrate high structural similarity throughout the total altitude interval, for low altitude (C-415), intermediate altitude (C-411), and high altitude (C-412) flights, and a high similarity only at low altitude (C-420) during an intermediate altitude flight.

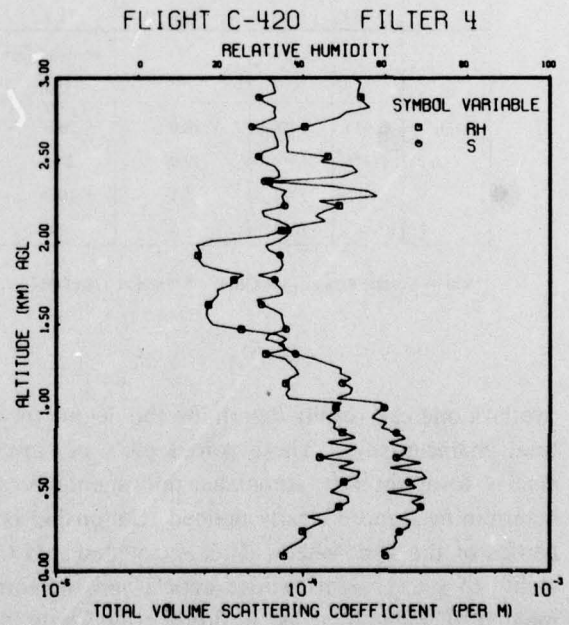
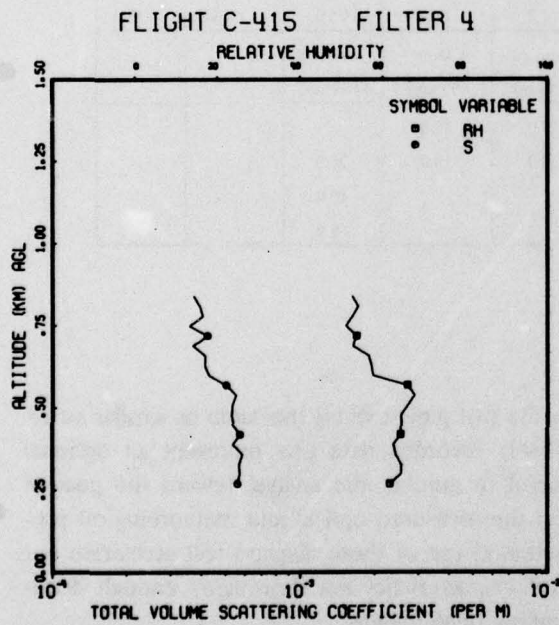
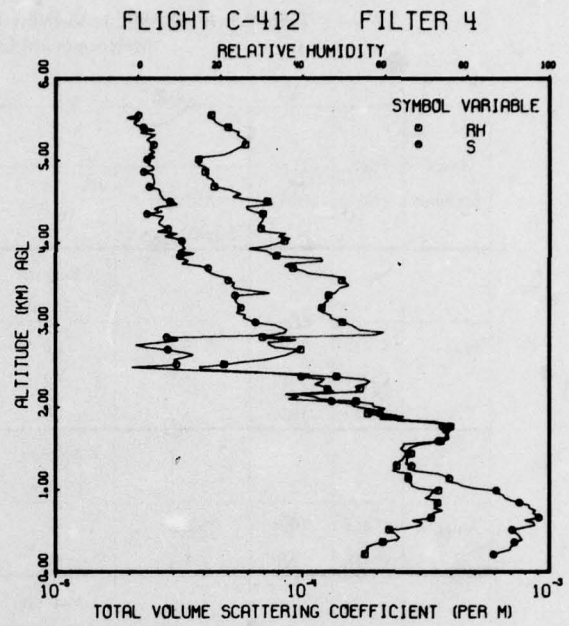
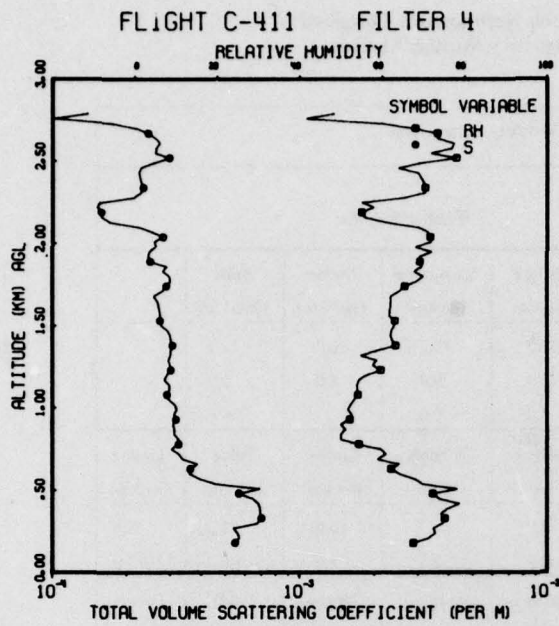

Fig. 8-10. Comparison of the Photopic Scattering Coefficient and Relative Humidity Profiles as Measured During Flights C-411, C-412, C-415 and C-420.

**Correlation with Relative Humidity.** An attempt was made to correlate the total volume scattering coefficient for filter 4 (pseudo-photopic) with the relative humidity for the SEEKVAL data [Duntley, *et al.* (1975a)]. These data indicated an approximately linear relationship between the log of the ratio of the total volume scattering coefficient to the Rayleigh total volume scattering coefficient,  $s(z)/_R s(z)$ , and the relative humidity  $RH$

$$\log s(z)/_R s(z) = 1.28 \frac{RH}{100} . \quad (8.2)$$

This was for a flight track in western Washington over forest near an agricultural area, removed from major sources of industrial pollution and auto emissions.

In an attempt to see if this relationship was equally valid for the OPAQUE III data, the nephelometer data from the vertical profile flight elements have been put into ratio form and graphed as a function of relative humidity in Figs. 8-11 for the same flights as Figure 8-10. The superimposed line is for the relationship indicated by Eq. 8.2 for the SEEKVAL data.

For the flights which showed a correlation between the Filter 4 total volume scattering coefficient and relative humidity (Flights C-411, C-412, and C-415) Figure 8-11 indicates a similar correlation for other filters, but the curves offset by filter, with the offset increasing with wavelength of filter. The offsets of the data from the SEEKVAL correlation line vary from flight to flight, and the slopes of the data also vary from being similar to SEEKVAL (Flight C-415) to being steeper than the SEEKVAL slope (Flight C-411 and C-412). The low altitude flight C-415 appeared to have a reasonable though not strong correlation in Fig. 8-10, but Fig. 8-11 indicates this correlation to be quite clear cut for all 4 filters.

Flight C-420 clearly shows a part of the data with no correlation and a part of the data with good correlation between total scattering and relative humidity for all four filters.

## EQUIVALENT ATTENUATION LENGTH AND BEAM TRANSMITTANCE

Equivalent attenuation length is presented for the path between ground level and altitude. At ground level the equivalent attenuation length is the reciprocal of the total scattering coefficient  $s(z)$ . As altitude increases, the equivalent attenuation length shows the cumulative effect of summing  $s(z)$  from ground level to altitude  $z$ .

The vertical beam transmittance starts at 1.0 at ground level and shows the cumulative effect of the summation of the total scattering coefficient with altitude.

For simultaneous data, or even for sequentially sampled data under reasonably stable and uniform aerosol conditions, the order by filter of the equivalent attenuation length  $\bar{L}$  and the beam transmittance should vary directly as the mean wavelength of the filters, i.e.,  $\bar{L}(\text{Filter 2}) < \bar{L}(4) < \bar{L}(3) < \bar{L}(5)$ . Five of the flights (C-411, C-412, C-414, C-418 and C-421) do not follow this order, primarily because the low altitude total scattering coefficients are not generally in order by filter, due to changes in the conditions between profiles. The flights with some regularity of attenuation length with filter are Flight C-413, C-416 and C-420 at most altitudes, and Flights C-410, C-415, C-419, and C-422 at all altitudes.

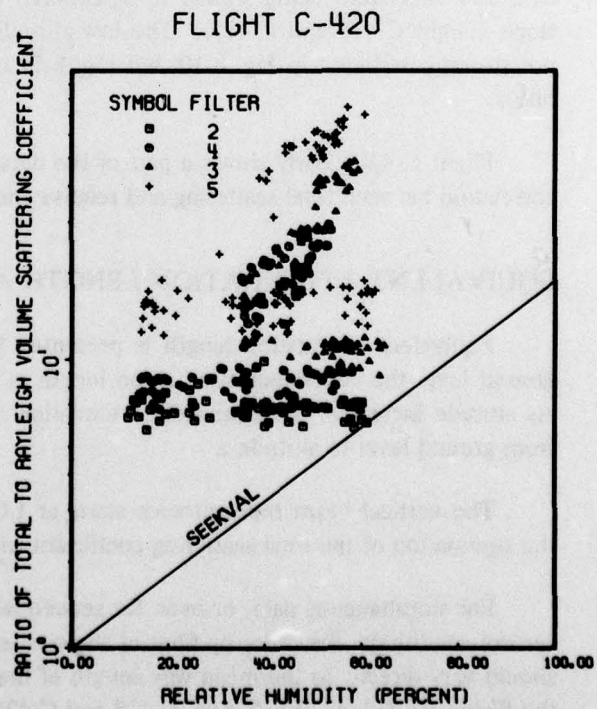
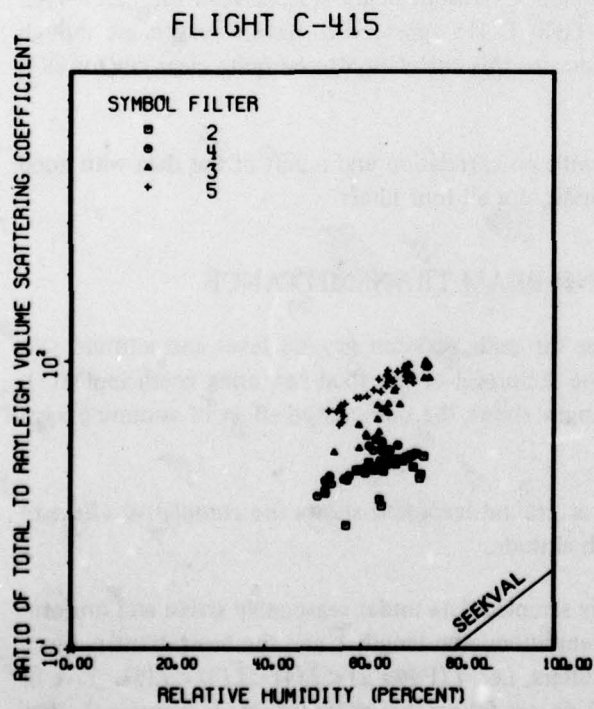
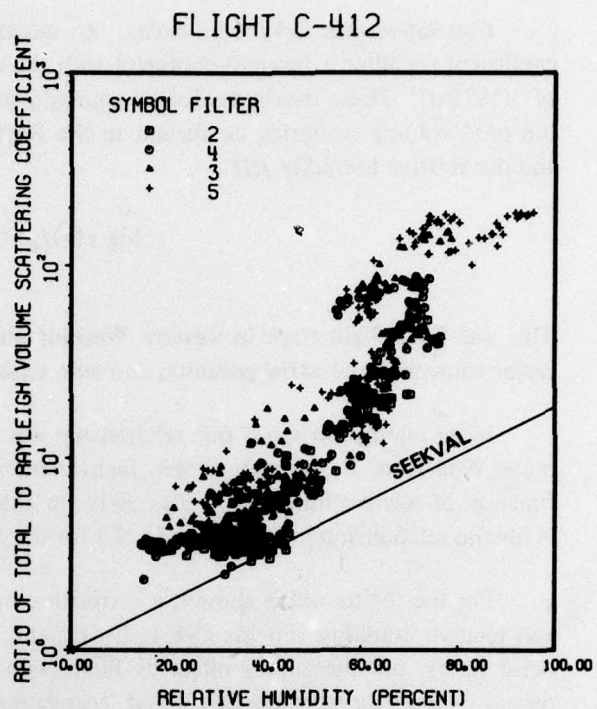
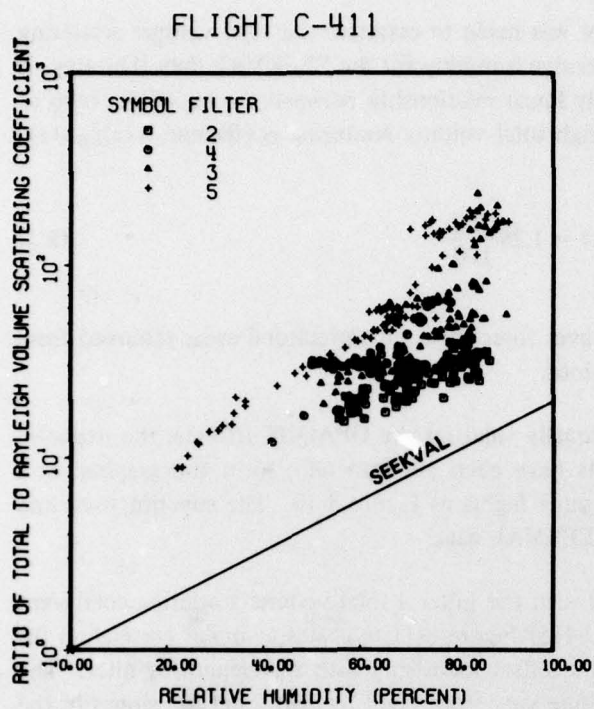

Fig. 8-11. Ratio of Total to Rayleigh Total Volume Scattering Coefficient as a Function of Relative Humidity for Flights C-411, C-412, C-415 and C-420.

*Equivalent Attenuation Length and Beam Transmittance Examples.* The equivalent attenuation length table can easily be used in Eq. 2.6 to obtain beam transmittance for various zenith angles for the upward path of sight and for various zenith angles for the downward path of sight.

## EXAMPLES

- A. For an upward path of sight at 60-degree zenith angle, with an object altitude  $z_1$  at 1800 meters, Eq. 2.6 would be written

$$T_{3600}(0, 60^\circ) = \exp \left\{ \left[ -1800\text{m}/\bar{L}(1800) \right] \sec 60^\circ \right\}.$$

Using the equivalent attenuation length for Flight C-412 Filter 4, Eq. 2.6 becomes

$$T_{3600}(0, 60^\circ) = \exp \left\{ \left[ -1800\text{m}/1830\text{m} \right] 2 \right\} = 0.140.$$

- B. For a downward path of sight at a zenith angle of 135 degrees from a sensor altitude of 900 meters, Eq. 2.6 would become

$$T_{1273}(900, 135^\circ) = \exp \left\{ \left[ -900\text{m}/\bar{L}(900) \right] |\sec 135^\circ| \right\}.$$

Again using the values from Flight C-412 Filter 4, Eq. 2.6 becomes

$$T_{1273}(900, 135^\circ) = \exp \left\{ \left[ -900\text{m}/1380\text{m} \right] 1.414 \right\} = 0.398.$$

## IRRADIANCE

*Downwelling.* The downwelling irradiance was measured during the straight and level flight elements and during the vertical profiles on each flight. During the straight and level flight elements, the intended aircraft flight attitude was 2½ degrees nose high and the dual irradiator was oriented to be horizontal during a +2½ degree pitch. The pitch and roll measurements during the straight and level flight elements indicated that average aircraft attitude was such that the dual irradiator was within ±3 degrees of true horizontal during most of the flights. Downwelling irradiance values for the straight and level flight elements for each flight are presented in columns 7 through 10 in Table 8.6. The corresponding sun zenith angles for each filter and altitude are also presented in columns 3 through 6. Columns 11 through 14 contain the ratio of the downwelling irradiance divided by the clear day irradiance for the photopic derived from Brown (1962). This takes out the effect of sun zenith angle. The ratio would be expected to vary with filter as well as cloud cover.

**Table 8.6. Downwelling Irradiance Measured by Dual Irradiometer During Straight and Level Flight Elements**

Flight No.	Average Altitude (meters)	Sun Zenith Angle (Degrees)				Downwelling Irradiance (w/m <sup>2</sup> μm)				Downwelling Irradiance/Irradiance from Brown			
		Filter 2	Filter 4	Filter 3	Filter 5	Filter 2	Filter 4	Filter 3	Filter 5	Filter 2	Filter 4	Filter 3	Filter 5
C-410	3183	25.2	34.1	25.3	34.8	1490	824	852	506	1.01	.63	.58	.39
	1328	25.5	29.2	25.4	29.8	1140	1210	1010	-	.77	.86	.68	-
	396	27.2	26.6	26.8	27.0	958	1050	956	724	.66	.72	.66	.50
C-411	2856	39.4	30.1	38.6	29.6	1440	1260	1010	660	1.06	.90	.84	.47
	1624	42.2	32.8	41.7	32.2	1310	1190	876	604	1.17	.89	.78	.44
	416	45.1	35.9	44.5	35.2	1100	613	763	709	1.06	.48	.72	.55
C-412	5643	35.6	-	34.9	-	1420	-	947	-	1.11	-	.73	-
	2877	39.9	-	39.1	-	1360	-	905	-	1.16	-	.76	-
	1642	43.3	-	42.5	-	1280	-	856	-	1.18	-	.77	-
	317	48.0	-	47.1	-	1040	-	743	-	1.07	-	.75	-
C-414	1334	-	40.2	40.4	40.1	-	1600*	1210*	734*	-	1.37	1.04	.63
C-415	851	34.4	35.2	34.4	35.1	640	724	758	445	.49	.56	.58	.34
	228	34.3	36.8	34.3	36.6	715	444	597	480	.55	.35	.46	.38
C-416	4571	40.0	-	40.4	-	1320	-	993	-	1.13	-	.86	-
	3070	38.2	49.0	38.5	49.7	1440	1040	1030	562	1.18	1.10	.85	.61
	1552	37.0	46.2	37.3	46.8	1500	1120	1070	596	1.20	1.10	.86	.60
	275	36.7	43.0	36.7	43.5	1410	1180	955	618	1.12	1.08	.76	.57
C-419	728	53.4	60.6	54.1	61.3	857	532	749	379	1.03	.84	.88	.62
	241	50.1	56.8	50.8	57.7	795	771	770	446	.87	1.04	.86	.63
C-420	3049	43.3	36.8	42.7	36.6	1190	1090	880	791	1.09	.87	.80	.63
	1066	46.3	38.5	45.7	38.1	1320	1270	895	719	1.30	1.05	.87	.59
	265	49.6	40.4	49.0	40.0	1150	1230	889	710	1.24	1.06	.94	.61
C-421	5845	39.3	47.8	39.4	48.3	1330	960	941	596	1.12	.98	.79	.62
	3385	39.2	45.1	39.2	45.6	1310	978	934	548	1.10	.94	.78	.53
	1568	39.9	42.6	39.7	43.0	1290	1140	967	646	1.10	1.03	.82	.59
	271	41.4	40.7	41.0	41.0	1240	833	892*	501	1.09	.72	.78	.44
C-422	1561	41.0	39.6	40.8	39.5	371*	370	295*	242*	.32	.31	.26	.20
	305	42.9	40.1	42.6	40.0	297	401*	191*	231*	.27	.34	.17	.20

\*Irradiometer greater than 3° from horizontal

The low-altitude downwelling irradiance values for pseudo-photopic Filter 4 for all the OPAQUE III flights are graphed in Fig. 8-12.

The symbols indicate the cloud categories used in Table 7.2. Since the altitudes for the lowest straight and level sequences for Filter 4 ranged between 217 and 1330 meters above ground level, they can be compared to the ground-level values of Brown (1952). The illuminance values of Brown for unobscured sun, and partial cloud have been converted to irradiance units and depicted as solid curves in Fig. 8-12.

All but one of the low altitude OPAQUE III irradiances are close to or less than the clear day irradiances of Brown. This seems reasonable since all of the data are for skies with scattered to broken clouds or fully overcast. The overcast point which is considerably higher than the Brown clear day curve is from C-414, with a large pitch and roll (see Table 8.6) and hence it represents a less accurate measurement of downwelling irradiance.

The average pitch of the aircraft during the vertical profile sequences was 5.8 degrees during ascent and -1.1 degrees during descent so that the dual irradiator was roughly +3.3 degrees from horizontal during ascent and -3.6 degrees from horizontal during descent. The aircraft heading was generally cross sun to minimize this effect. Generally, however, the orientation of the dual irradiator during the vertical profile could not be kept within as close an angular tolerance as during the straight and level flight elements. Therefore, it is preferable to use the values from the straight and level sequences in Table 8.6 for the absolute values of downwelling irradiance and to use the vertical profile graphs in Section 7.3 to indicate the variability of downwelling irradiance with space and time during the flight.

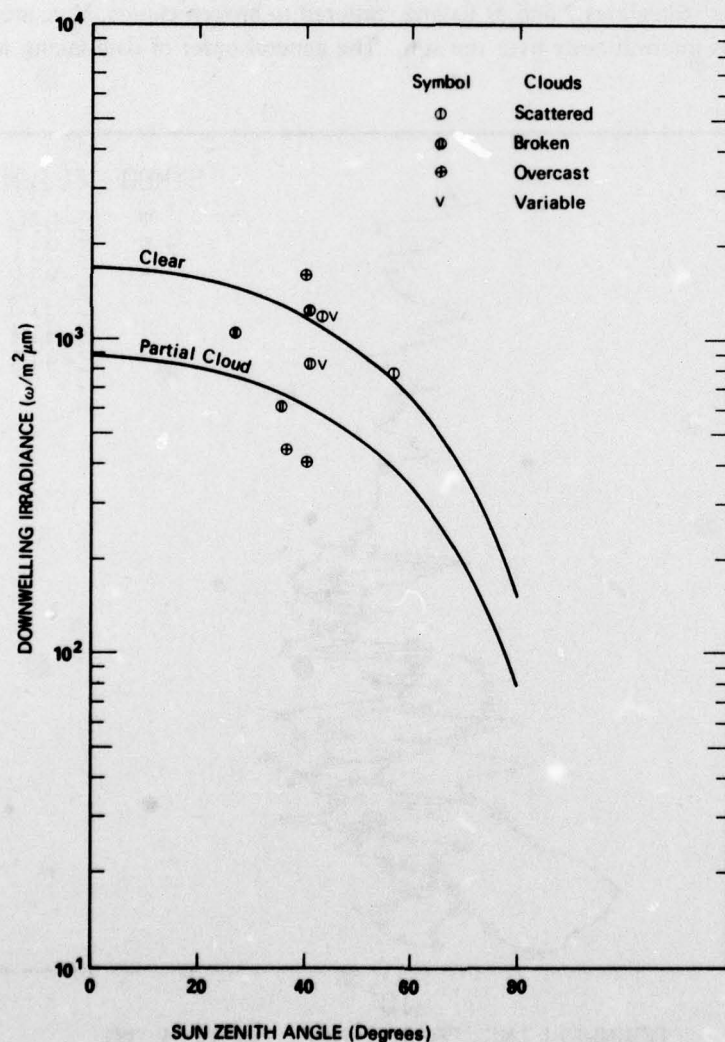

Fig. 8-12. Project OPAQUE III Low Altitude Downwelling Irradiance for Filter 4 Pseudo-Photopic Compared to Brown (1952).

Vertical profiles wherein the orientation of the irradiometer toward the sun exceeded  $\pm 3$  degrees from horizontal occurred during eight flights. Hence, the following vertical profiles of irradiance should be used with caution: Flight C-410, filter 5; Flight C-411, all filters; Flight C-412, filters 2 and 3; Flight C-413, all filters; Flight C-414, all filters; Flight C-418, filter 5; Flight C-419, filter 2; and Flight C-422, filters 2, 3 and 4.

In the graphs of downwelling irradiance versus altitude in Section 7.3, the mostly clear to scattered flights, (cloud category 1) are either reasonably regular due to the absence of clouds (C-412) or have portions of the profile with stable irradiances (C-411). The other two flights with some areas of stable irradiance are Flight C-416 and C-421, cloud category 2, mostly scattered to broken clouds. The mostly overcast flights, category 4 (C-415 Filter 4, 5; C-418 Filters 4, 5; and C-422) are generally slightly irregular with altitude, and are generally with filter 2 > 4 > 3 > 5 but with lots of crossovers. The remainder of the flights (categories 2 and 3) having scattered to broken clouds, have areas of great variability indicating clouds intermittently over the sun. The general order of data-taking was Filter 2 dur-

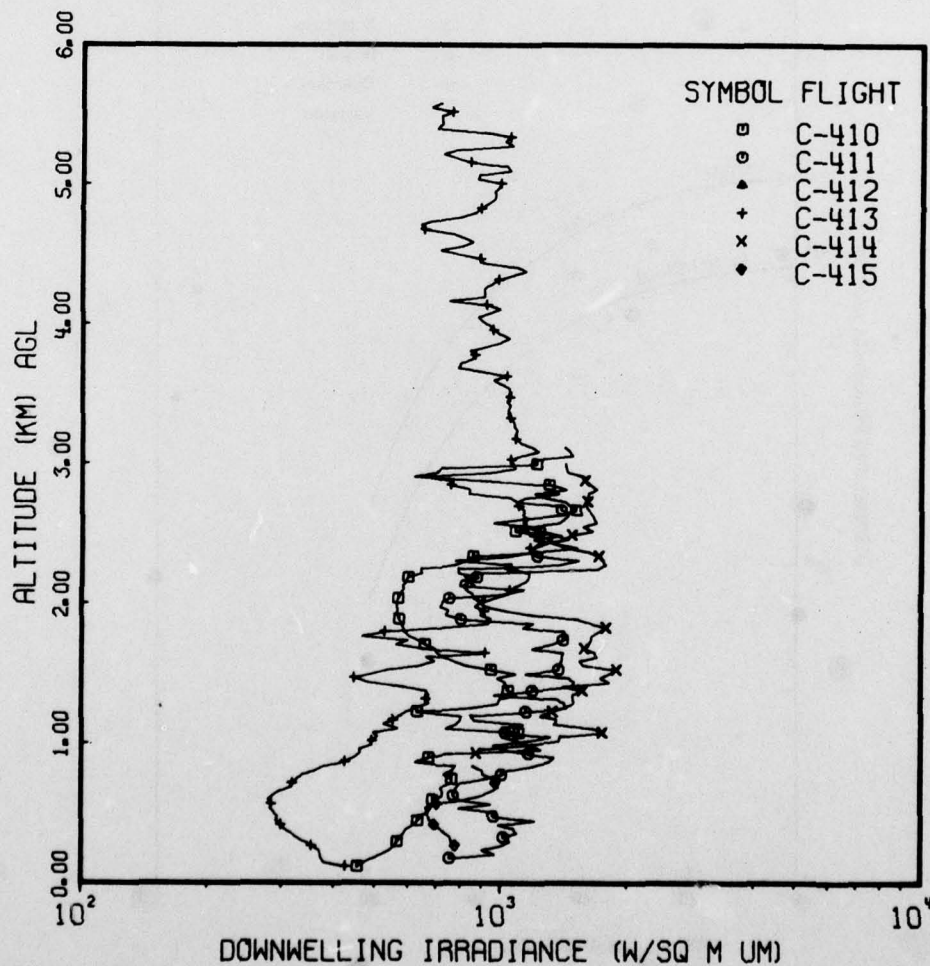

Fig. 8-13. Downwelling Irradiance for Filter 4 Pseudo-Photopic for six OPAQUE III flights, 4 through 29 July 1977.

ing ascent, Filter 3 during descent, Filter 4 during ascent and finally Filter 5 during the last descent. In general, for roughly comparable times Filter 2>4>3>5. Major exceptions were the more variable portions of profiles indicating clouds.

Downwelling irradiance for Filter 4 pseudo-photopic has been graphed separately for the first six flights during July in Fig. 8-13 and for the six flights in August in Fig. 8-14. There are no irradiance data for Filter 4 Flight C-412. The solar zenith angle range is relatively small for both graphs (27° to 54° for Fig. 8-13 and 37° to 60° for Fig. 8-14) so most of range of values reflect the variability of amount and thickness of cloud cover.

*Albedo.* The albedo is the ratio of the upwelling to downwelling irradiance. The albedos for the OPAQUE III airborne data are summarized in Table 8.7. The albedos for the flights over water are presented first, and then the flights over land. The low altitude albedos for filters 2, 4, 3, and 5 lie in a reasonable range for cultivated fields with growing crops. Filter 4 values are expected to be slightly

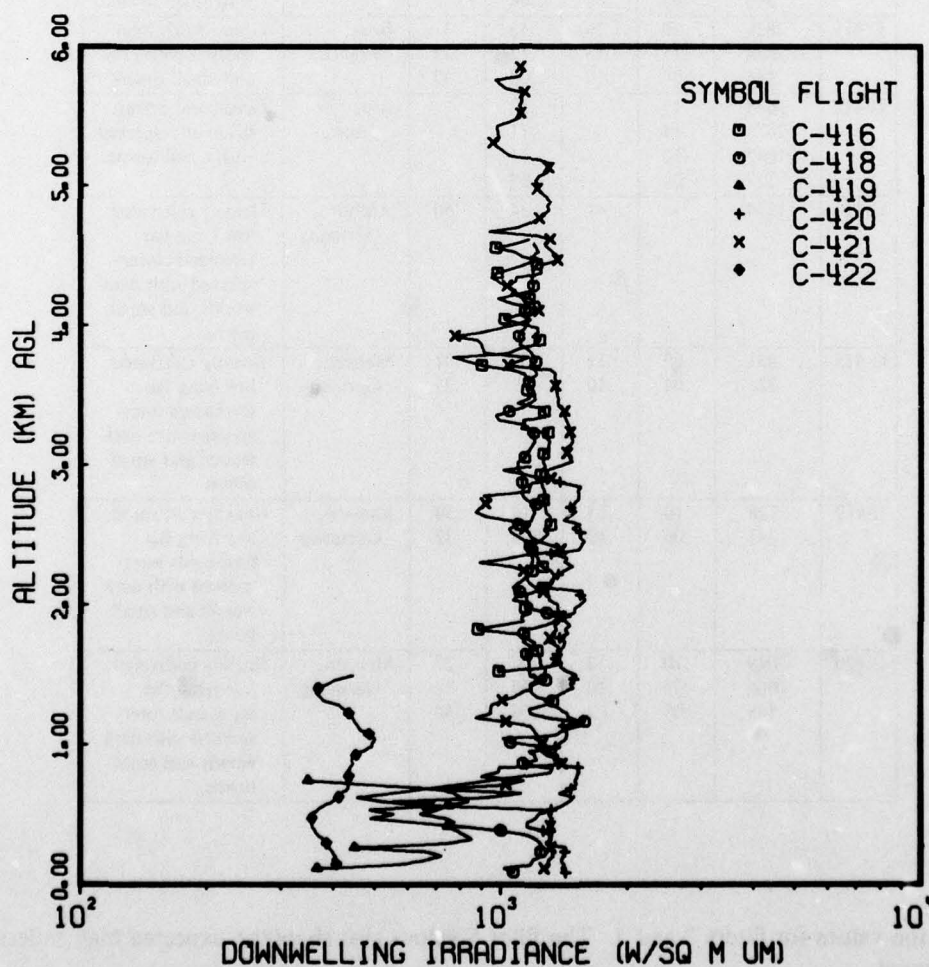

Fig. 8-14. Downwelling Irradiance for Filter 4 Pseudo-Photopic for six OPAQUE III Flights, 1 through 11 August 1977.

**Table 8.7. Albedo as Measured by the Dual Irradiometer During Straight and Level Flight Elements**

Flight No.	Altitude (meters)	Albedo				Track	Terrain Description
		Filter 2	Filter 4	Filter 3	Filter 5		
C-416	4571	.14	-	.09	-	Rodby, Denmark	Water, windspeed 6.2-6.7 mps
	3070	.14	.12	.08	.10		
	1552	.07	.11	.05	.07		
	275	.05	.06	.04	.05		
C-421	5845	.14	.17	.11	.14	Rodby, Denmark	Water, windspeed 1.5-5.1 mps
	3385	.13	.12	.09	.14		
	1568	.08	.09	.08	.12		
	271	.05	.07	.05	.11		
C-422	1561	.14	.12	.11	.08	Rodby, Denmark	Water, windspeed 4.1-4.6 mps
	305	.08	.07	.07	.06		
C-410	3183	.14	.16	.11	.31	Bruz, France	Green and brown fields interspersed with small towns
	1328	.11	.07				
	396	.05	.08	.08			
C-411	2856	.20	.19	.12	.31	Bruz, France	Green fields interspersed with gray and small towns
	1624	.15	.15	.12	.33		
	416	.09	.10	.08	.32		
C-412	5643	.15		.12		Bruz, France	Green and brown fields interspersed with small towns
	2877	.14		.11			
	1642	.12		.11			
	317	.08		.08			
C-414	1334	-	.41	.34	.50	Ahlhorn, Germany	Heavily cultivated low lying flat farmlands interspersed with dark woods and small towns
C-415	851	.09	.11	.09	.31	Meppen, Germany	Heavily cultivated low lying flat farmlands interspersed with dark woods and small towns
	228	.04	.10	.07	.25		
C-419	728	.10	.15	.10	.34	Meppen, Germany	Heavily cultivated low lying flat farmlands interspersed with dark woods and small towns
	241	.06	.10	.08	.32		
C-420	3049	.10	.12	.08	.27	Meppen, Germany	Heavily cultivated low lying flat farmlands interspersed with dark woods and small towns
	1066	.07	.10	.08	.27		
	265	.05	.07	.06	.30		

higher than the values for filters 2 and 3. The filter 5 values also show the expected high reflectance in the near infrared.

The low altitude albedos over water are also in a reasonable range for the low wind speeds. The

over-the-water albedos are relatively neutral spectrally as is reasonable since most of the upwelling irradiance is from reflected sky and sunlight and water reflectance is essentially neutral in this region of the spectrum.

The albedos generally increase as expected with altitude.

### **8.3. SUMMARY**

Twelve project data flights have been presented and evaluated with specific attention afforded to profiles of total volume scattering coefficient and downwelling irradiance. Selected meteorological measurements taken concurrently with these profiles data have been included as background information and for structural comparisons with the scattering coefficient profiles.

The data for OPAQUE III represent flights made during the summer, and some data missions were flown under poor to marginal weather conditions. These flights are welcome additions to the real world documentation afforded by the OPAQUE series.

The OPAQUE III flights included some ground level measurements of total volume scattering coefficient in Filter 4. Also most vertical profiles were flown down to very low altitudes (270 m to 30 m). Thus the low altitude scattering profile with altitude is better documented on this series of flights than ever before. We are not always able to fly so low near the flight track so it is still recommended that continued emphasis be placed upon the need for documenting very low altitude and ground level optical properties.

## 9. ACKNOWLEDGEMENTS

To be conducted successfully, Project OPAQUE III required the active support of many organizations and individuals. To all those who so willingly contributed their skills, talents, and inspiration, the authors gratefully acknowledge their debt.

Dr. Robert W. Fenn, Chief, Atmospheric Optics Branch, AFGL  
Scientific Counsel and Technical Monitor

Maj. Ted S. Cress, USAF, Project Organization and Coordination

Mr. Raymond S. Silva, Operational Services Division, AFGL, for  
continuing logistical support and advice.

4950th Test Wing (DOC & MAOP) Wright-Patterson Air Force Base, for all aircrew assignments

Lt. Col. David J. Schnegelberger, Task Force Commander & Navigator

Maj. Robert J. Mitchell, Task Force Commander & Pilot

Maj. Michael W. Bartlett, Navigator

Capt. Norman A. Rice, Aircraft Commander

Capt. Harold G. Shimek, Aircraft Commander

Capt. Ralph E. Brands, Pilot

M/Sgt. Kenneth M. Bender, Loadmaster

M/Sgt. David R. Roby, Loadmaster

S/Sgt. Ronald H. Spencer, Flight Engineer

S/Sgt. Gary D. Faubus, Flight Engineer

S/Sgt. Anthony J. Martin, Crew Chief

S/Sgt. Steven P. Wood, Maintenance Specialist

S/Sgt. Frank Duckworth, Maintenance Specialist

Sgt. Randy E. Lukenbach, Maintenance Specialist

SRA, Neil T. Tyson, Ass't Crew Chief

Mr. Warren K. Soward, Maintenance Specialist

Mr. Clifford V. Meadow, Maintenance Specialist

Mr. Jack B. White, Maintenance Specialist

Visibility Laboratory, Technical Field Team

Mr. Nils R. Persson, Jr., Technical Flight Crew

Mr. George F. Simas, Ground Station Crew

Mr. Steven J. Bettinger, Ground Station Crew

**Visibility Laboratory, Data Processing and Analysis Team**

Mr. Nils R. Persson, Jr.  
Ms. Janet E. Shields  
Ms. Catharine F. Edgerton  
Mr. Steven J. Bettinger

**Visibility Laboratory, Editorial and Reproduction Team**

Mr. John C. Brown  
Mr. James Rodriguez  
Ms. Alicia G. Hill

**Physics Laboratory of the National Defense Research Organization (TNO)**

P. O. Box 2864, The Hague, Netherlands

Ir T. Bakker  
Ir J. Van Schie  
Ir J. Winters

**Meppen Artillery Test Range (Erprobungstelle 91 der Bundes Wehr)**

447 Meppen, Germany

Mr. Lichtenberg  
Mr. Husemann

**Institute for Physics of the Atmosphere**

8031 Oberpfaffenhofen, Post Wessling, Germany

Dr. von Redwitz

**Centre d'Electronique de L'Armement (CELAR)**

35170 Bruz, France

Mr. Marius Thorat  
Mr. Albert Seven

**Lorient/Lann Bihoue Air Base**

Lorient, France

Frigate Capt. Montanier, Base Cmdr  
Capt. Ruty, Opns Officer

**Danish Defense Research Establishment**

Osterbrogades Kaserne, Copenhagen, Denmark

Mr. N. C. Nielsen

## 10. REFERENCES

- Barteneva, O. D. (1960), "Scattering Functions of Light in the Atmospheric Boundary Layer," Bull. Acad. Sci. U.S.S.R., Geophysics Series, 1237-1244.
- Beutell, R. G. and A. W. Brewer (1949), "Instruments for the Measurement of the Visual Range," J. Sci. Instr. 26, 357-359.
- Boileau, A. R. (1964), "VI. Atmospheric Properties," Appl. Opt. 3, 570-581.
- Brown, D. R. E. (1952), Natural Illumination Charts, Report 374-1, Project Ns-714-100, Department of the Navy, Bureau of Ships, Washington, D. C.
- Douglas, C. A. and L. L. Young (1945), "Development of Transmissometer for Determining Visual Range," U.S. Department of Commerce, Civil Aeronautics Administration, Washington, D.C., Technical Development Report No. 47.
- Duntley, S. Q., A. R. Boileau, and R. W. Preisendorfer (1957), "Image Transmission by the Troposphere I," J. Opt. Soc. Am. 47, 499-506.
- Duntley, S. Q., R. W. Johnson, and J. I. Gordon (1964), "Ground-Based Measurements of Earth-to-Space Beam Transmittance, Path Radiance, and Contrast Transmittance," University of California, San Diego, Scripps Institution of Oceanography, Visibility Laboratory, Tech. Doc. Report No. AL-TDR-64-245.
- Duntley, S. Q. (1969), "Directional Reflectance of Atmospheric Paths of Sight," Duntley Rep. No. 69-1.
- Duntley, S. Q., R. W. Johnson, J. I. Gordon, and A. R. Boileau (1970a), "Airborne Measurements of Optical Atmospheric Properties at Night," University of California, San Diego, Scripps Institution of Oceanography, Visibility Laboratory, SIO Ref. 70-7, AFCRL-70-0137.
- Duntley, S. Q., C. F. Edgerton, and T. J. Petzold (1970b), "Atmospheric Limitations on Remote Sensing of Sea Surface Roughness by Means of Reflected Daylight," University of California, San Diego, Scripps Institution of Oceanography, Visibility Laboratory, SIO Ref. 70-27.
- Duntley, S. Q., R. W. Johnson, and J. I. Gordon (1972a), "Airborne Measurements of Optical Atmospheric Properties in Southern Germany," University of California, San Diego, Scripps Institution of Oceanography, Visibility Laboratory, SIO Ref. 72-64, AFCRL-72-0255.
- Duntley, S. Q., R. W. Johnson, and J. I. Gordon (1972b), "Airborne and Ground-Based Measurements of Optical Atmospheric Properties in Central New Mexico," University of California, San Diego, Scripps Institution of Oceanography, Visibility Laboratory, SIO Ref. 72-71, AFCRL-72-0461.

Duntley, S. Q., R. W. Johnson, and J. I. Gordon (1972c), "Airborne Measurements of Optical Atmospheric Properties, Summary and Review," University of California, San Diego, Scripps Institution of Oceanography, Visibility Laboratory, SIO Ref. 72-82, AFCRL-72-0593.

Duntley, S. Q., R. W. Johnson, and J. I. Gordon (1974), "Airborne and Ground-Based Measurements of Atmospheric Properties in Southern Illinois," University of California, San Diego, Scripps Institution of Oceanography, Visibility Laboratory, SIO Ref. 74-25, AFCRL-TR-74-0298.

Duntley, S. Q., R. W. Johnson, and J. I. Gordon (1975a), "Airborne Measurements of Optical Atmospheric Properties in Western Washington," University of California, San Diego, Scripps Institution of Oceanography, Visibility Laboratory, SIO Ref. 75-24, AFCRL-TR-75-0414.

Duntley, S. Q., R. W. Johnson, and J. I. Gordon (1975b), "Airborne Measurements of Optical Atmospheric Properties, Summary and Review II," University of California, San Diego, Scripps Institution of Oceanography, Visibility Laboratory, SIO Ref. 75-26, AFCRL-TR-75-0457.

Duntley, S. Q., R. W. Johnson, and J. I. Gordon (1976), "Airborne Measurements of Optical Atmospheric Properties in Northern Germany," University of California, San Diego, Scripps Institution of Oceanography, Visibility Laboratory, SIO Ref. 76-17, AFGL-TR-76-0188.

Duntley, S. Q., R. W. Johnson, and J. I. Gordon (1977), "Airborne Measurements of Atmospheric Volume Scattering Coefficients in Northern Europe, Spring 1976," University of California, San Diego, Scripps Institution of Oceanography, Visibility Laboratory, SIO Ref. 77-8, AFGL-TR-77-0078.

Duntley, S. Q., R. W. Johnson, and J. I. Gordon (1978), "Airborne Measurements of Atmospheric Volume Scattering Coefficients in Northern Europe, Fall 1976," University of California, San Diego, Scripps Institution of Oceanography, Visibility Laboratory, SIO Ref. 78-3, AFGL-TR-77-0239.

Edgerton, C. F. (1967), "Relationship Between Meteorological Conditions and Optical Properties of the Atmosphere," University of California, San Diego, Scripps Institution of Oceanography, Visibility Laboratory, SIO Ref. 67-27.

Gordon, J. I., J. L. Harris, and S. Q. Duntley (1963), "Earth-to-Space Contrast Transmittance Measurements from Ground Stations," University of California, San Diego, Scripps Institution of Oceanography, Visibility Laboratory, SIO Ref. 63-2.

Gordon, J. I., J. L. Harris, Sr., and S. Q. Duntley (1973), "Measuring Earth-to-Space Contrast Transmittance from Ground Stations," *Appl. Opt.* 12, 1317-1323.

List, R. J. (1966), *Smithsonian Meteorological Tables*, 6th Revised Ed., Smithsonian Miscellaneous Collections, Vol. 114, Smithsonian Institution; Washington, D.C.

Middleton, W.E.K. (1952), "Vision Through the Atmosphere," Chapter 10, University of Toronto Press.

USNAF TP-133, U.S. Naval Avionics Facility (1962), "Handbook, Operation and Service Instructions Aerograph Sets AN/AMQ-17 and AN/AMQ-18," Indianapolis 18, Indiana.

U.S. Standard Atmosphere (1962), U.S. Government Printing Office, Washington, D.C. 20402.

U.S. Standard Atmosphere Supplements (1966), U.S. Government Printing Office, Washington, D.C. 20402.