

AD-A068 672

GENERAL DYNAMICS/POMONA CALIF POMONA DIV
FOAM-FILLED FIBERGLASS RADOMES. (U)
MAR 79 W L MACTURK

F/6 11/5

UNCLASSIFIED

M-24-6-678

NAVSEA-MT-100

N66001-77-C-0139

NL

1 of 3

AD
A068672



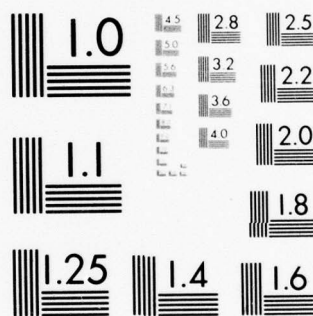

MICROCOPY RESOLUTION TEST CHART
NATIONAL BUREAU OF STANDARDS-1963-A



12
B.S.



LEVEL II

NAVSEA MT 100
(NOSC TR 395)

AD A068672

NAVSEA MT 100
(NOSC TR 395)

DDC
MAY 11 1979
C

NAVSEA MT 100
(NOSC TR 395)

FOAM-FILLED FIBERGLASS RADOMES

W. L. Macturk
General Dynamics
(N66001-77-C-0139WJC)

16 March 1979

Final Report:
June 1977 - July 1978

DDC FILE COPY

APPROVED FOR PUBLIC RELEASE; DISTRIBUTION UNLIMITED

79 05 10 005

ADMINISTRATIVE INFORMATION

The work in this report was sponsored by the Naval Sea Systems Command as part of the Manufacturing Technology Program. The data discussed in this document was prepared General Dynamics, Pomona Division, under contract N66001-77-C-0139WJC.

18 NAVSEA, NOSC 19 MT-100, TR-395

UNCLASSIFIED
 SECURITY CLASSIFICATION OF THIS PAGE (When Data Entered)

REPORT DOCUMENTATION PAGE		READ INSTRUCTIONS BEFORE COMPLETING FORM
1. REPORT NUMBER NAVSEA MT 100 (NOSC TR 395)	2. GOVT ACCESSION NO.	3. RECIPIENT'S CATALOG NUMBER Rept.
4. TITLE (and Subtitle) FOAM-FILLED FIBERGLASS RADOMES	5. TYPE OF REPORT & PERIOD COVERED Final June 1977-July 1978	6. PERFORMING ORG. REPORT NUMBER M-24-6-678
7. AUTHOR(s) William L. MacTurk	8. CONTRACT OR GRANT NUMBER(s) N66001-77-C-0139	9. PROGRAM ELEMENT, PROJECT, TASK AREA & WORK UNIT NUMBERS
9. PERFORMING ORGANIZATION NAME AND ADDRESS General Dynamics Pomona Division 1675 West Mission Blvd., P.O. Box 2507 Pomona, CA 91766	10. CONTROLLING OFFICE NAME AND ADDRESS Naval Ocean Systems Center 271 Catalina Blvd. San Diego, CA 92152	11. REPORT DATE 16 March 1979
11. CONTROLLING OFFICE NAME AND ADDRESS Naval Ocean Systems Center 271 Catalina Blvd. San Diego, CA 92152	12. REPORT DATE 16 March 1979	13. NUMBER OF PAGES 180
14. MONITORING AGENCY NAME & ADDRESS (if different from Controlling Office) Naval Sea Systems Command Washington, D.C. 20360	15. SECURITY CLASS. (of this report) Unclassified	15a. DECLASSIFICATION/DOWNGRADING SCHEDULE
16. DISTRIBUTION STATEMENT (of this Report) Approved for public release; distribution unlimited.		
17. DISTRIBUTION STATEMENT (of the abstract entered in Block 20, if different from Report)		
18. SUPPLEMENTARY NOTES		
19. KEY WORDS (Continue on reverse side if necessary and identify by block number) Radomes Foam Core Composite Facings, Glass/Polyester Fiberglass Molding Foam Molding		
20. ABSTRACT (Continue on reverse side if necessary and identify by block number) The work contained in this report details the activities accomplished from June of 1977 to July of 1978 on the manufacturing process development of a 40" diameter foam filled fiberglass radome by the Advanced Manufacturing Technology Section at General Dynamics, Pomona Division.		

6

9

14

10

15

11

12/252p.

D D C
 R R P M P
 MAY 11 1979
 C

40 IN.

147850

UNCLASSIFIED

40 in.

SECURITY CLASSIFICATION OF THIS PAGE (When Data Entered)

This program sponsored by Naval Ocean Systems Center, San Diego, California, under contract N66001-77-C-0139 WJC enabled the transition from a development phase to a production ready manufacturing process whereby low cost, light weight radomes with excellent design advantages could be fabricated in normal production environments for deployment on both land based and shipboard installations.

The Navy Phalanx Ship/Gun System now under production at General Dynamics, Pomona, which utilizes a 40" diameter hemispherical radome window as the enclosure for the search antenna unit, has adopted the fabrication process demonstrated in this program.

This final report also contains the Test Plan and Results on the testing of this radome as concurred by NOSC, San Diego, and Manufacturing Technology, General Dynamics, Pomona. Test results appear as appendices at the end of report with the appropriate organization group at General Dynamics who conducted the tests so designated.

A development Process Specification (D.P.S.) detailing the manufacturing steps pursued in the construction of the radome is also appended to this final report along with vendor information as to the materials employed in the foam/fiberglass construction of this radome window.

UNCLASSIFIED

SECURITY CLASSIFICATION OF THIS PAGE (When Data Entered)

CDRL A003
Code Ident 9243
M-24-6-678

Foreword

This Final Progress Report covers the activities performed from June 1977 through July 1978, under contract N66001-77-0139 WJC.

The program was conducted within the Advanced Manufacturing Technology Laboratory at the Pomona Division of General Dynamics. The cognizant responsibility is under Dr. Marvin C. Abrams, Chief of Advanced Manufacturing Technology. Mr. William L. MacTurk is the program director and principal investigator.

The work has been authorized by the Naval Sea Systems Command, Manufacturing Technology Code SEA 035, Mr. Harry Byron. The contract is being monitored and technical direction provided by the Naval Ocean Systems Center, Code 9243, Mr. John Markall.

PREPARED BY: W. L. MacTurk
W. L. MacTurk
Senior Manufacturing Development Specialist
Advanced Manufacturing Technology

APPROVED BY: M. C. Abrams
M. C. Abrams, Chief
Advanced Manufacturing Technology

ACCESSION for	
NTIS	File Section <input checked="" type="checkbox"/>
DDC	Ball Section <input type="checkbox"/>
UNANNOUNCED	<input type="checkbox"/>
JUSTIFICATION	<input type="checkbox"/>
BY _____	
DISTRIBUTION/AVAILABILITY NOTES	
Dist.	TOTAL
A	

CDRL A003
Code Ident 9243
M-24-6-678

ABSTRACT

The work contained in this report details the activities accomplished from June of 1977 to July of 1978 by the Advanced Manufacturing Technology Section at General Dynamics, Pomona Division, on the manufacturing process development of a 40" diameter foam-filled fiberglass radome.

This program, sponsored by Naval Ocean Systems Center, San Diego, California, under contract N66001-77-C-0139 WJC, enabled the transition from a development phase to a production-ready manufacturing process whereby low-cost, lightweight radomes with excellent design advantages could be fabricated in normal production environments for deployment on both landbased and shipboard installations.

The Navy Phalanx Ship/Gun System now under production at General Dynamics Pomona, which utilizes a 40" diameter hemispherical radome window as the enclosure for the search antenna unit, has adopted the fabrication process demonstrated in this program.

This final report also contains the test plan and results on the testing of this radome as concurred by NOSC, San Diego, and Manufacturing Technology, General Dynamics, Pomona. Test results appear as appendices at the end of report with the appropriate organization group that conducted the tests designated.

A Development Process Specification (D.P.S.) detailing the manufacturing steps pursued in the construction of the radome is also appended to this final report along with vendor information as to the materials employed in the foam/fiberglass construction of this radome window.

CDRL A003
Code Ident 9243
M-24-6-678

TABLE OF CONTENTS

<u>SECTION</u>	<u>SUBJECT</u>	<u>STARTING PAGE</u>
	FOREWORD AND APPROVAL SHEET	ii
	ABSTRACT	iii
	TABLE OF CONTENTS	iv
	LIST OF FIGURES	vi
1.0	OBJECTIVE	1
2.0	INTRODUCTION	2
3.0	ENGINEERING APPROACH AND RESULTS	4
3.1	SPIN FORMING OF OUTER ALUMINUM HEMISPHERE	4
3.2	SPIN FORMING INNER ALUMINUM HEMISPHERE	5
3.3	ATTACHMENT OF BASE PLATES TO OUTER AND INNER ALUMINUM	5
3.4	MACHINING OF ALUMINUM HEMISPHERES	5
3.5	INNER AND OUTER MOLD ASSEMBLY	13
3.6	COMPLETED RADOME WINDOW	17
3.7	VENDOR HONEYCOMB RADOME WINDOW	17
3.8	FOAM MACHINE	18
3.9	COST ANALYSIS	19
4.0	RESULTS ANALYSIS - SEARCH RADOME	57
APPENDIX A	TEST PLAN - FOAM FILLED FIBERGLASS RADOMES	A-1
APPENDIX B	STRUCTURAL INTEGRITY - COMPRESSIVE BUCKLING FORCE	B-1 B-1
APPENDIX C	R.F. TRANSMISSION LOSS - INSERTION LOSS - SEARCH RADOME	C-1
APPENDIX D	SURFACE FINISH OF RADOME	D-1
APPENDIX E	THERMAL TRANSMISSION - SOLAR RADIATION	E-1
APPENDIX F	ICE RETENTION ON RADOME	F-1
APPENDIX G	ACOUSTIC ISOLATION - INSERTION LOSS	G-1
APPENDIX H	STATIC PROPERTIES OF FOAM CORE/FACINGS	H-1
APPENDIX I	DIMENSIONAL CONSTRAINTS	I-1
APPENDIX J	ENVIRONMENTAL TESTING AT TEMPERATURE EXTREMES	J-1
APPENDIX K	FUNGUS RESISTANCE OF FOAM SUBSTRATE AND FACINGS	K-1

CDRL A003
Code Ident 9243
M-24-6-678

TABLE OF CONTENTS (continued)

<u>SECTION</u>	<u>SUBJECT</u>	<u>STARTING PAGE</u>
APPENDIX L	DIELECTRIC CONSTANT AND DISSIPATION FACTORS OF FOAM CORE/FACINGS	L-1
APPENDIX M	WEIGHT OF SEARCH RADOME	M-1
APPENDIX N	TORSION REQUIREMENTS ON HARD POINTS OF RADOME	N-1
APPENDIX O	DESIGN INSTRUCTION - PHALANX CLOSE-IN- WEAPON-SYSTEM	O-1
APPENDIX P	DEVELOPMENT PROCESS SPECIFICATION (D.P.S.) SEARCH RADOME	P-1
APPENDIX Q	RADOME FORMAL DRAWINGS AND FABRICATION SKETCHES	Q-1

LIST OF FIGURES

<u>FIGURE</u>	<u>DESCRIPTION</u>	<u>PAGE</u>
1	PROGRAM CONDUCT	26
2	SPIN FORMING OF A 40" DIAMETER NAVAL ALUMINUM HEMISPHERE	27
3	60" DIAMETER 5/8" THICK ALUMINUM PLATE	28
4	SPIN FORMING 60" DIAMETER ALUMINUM PLATE	29
5	SPIN FORMING 60" DIAMETER ALUMINUM PLATE	30
6	SPIN FORMING 60" ALUMINUM PLATE	31
7	COMPLETED SPUN FORMED ALUMINUM PLATE INTO 40" DIAMETER HEMISPHERE	32
8	MEASURING DIAMETER OF 40" NAVAL ALUMINUM HEMISPHERE	33
9	MEASURING DIAMETER OF 39.472" NAVAL ALUMINUM HEMISPHERE	34
10	DIMENSIONING OF THE ARC OF A 40" NAVAL ALUMINUM HEMISPHERE	35
11	NAVAL ALUMINUM HEMISPHERES POLISHED TO A 5 MICRO INCH FINISH	36
12	FOAM FILLED/FIBERGLASS RADOME WITH OUTER AND INNER NAVAL ALUMINUM HEMISPHERE	37
13	GEL COATING ALUMINUM HEMISPHERES	38
14	APPLICATION OF CHOPPED FIBERGLASS TO ALUMINUM HEMISPHERE	39
15	REMOVAL OF AIR AND EXCESS RESIN FROM CHOPPED FIBERGLASS BY ROLLERS	40
16	APPLICATION OF 1 OZ. MAT TO BASE OF CHOPPED FIBERGLASS ALUMINUM HEMISPHERE	41
17	FIBERGLASS MOLD "GLASSED IN" TO TABLE TOP	42
18	SUPPORTING STRUCTURE FOR FIBERGLASS MOLD	43
19	OUTER MOLD ASSEMBLY BONDED TO TABLE STRUCTURE	44
20	REMOVAL OF OUTER ALUMINUM HEMISPHERE FROM OUTER MOLD ASSEMBLY	45
21	REMOVAL OF OUTER ALUMINUM HEMISPHERE FROM OUTER MOLD ASSEMBLY	46
22	REMOVAL OF INNER PLUG FROM INNER MOLD ASSEMBLY	47

CDRL A003
Code Ident 9243
M-24-6-678

LIST OF FIGURES (continued)

<u>FIGURE</u>	<u>DESCRIPTION</u>	<u>PAGE</u>
23	19" DIAMETER NAVAL RADOME WINDOW	48
24	OUTER AND INNER MOLD ASSEMBLY NAVAL RADOME TOOLING	49
25	QUADRANT HEMISPHERICAL SEARCH RADOME	50
26	QUADRANT TEMPLATE	50
27	QUADRANT TEMPLATE .062" ALUMINUM	51
28	CIRCULAR TEMPLATE .062" ALUMINUM	51
29	TEMPLATE FOR CUTTING GLASS CLOTH FOR HEMISPHERICAL SEARCH RADOME	52
30	TEMPLATE FOR CUTTING GLASS CLOTH CAP FOR HEMISPHERICAL SEARCH RADOME	53
31	NAVAL RADOME MOLD ASSEMBLY AFTER OVEN TEMPERATURE CURE	54
32	COMPLETE FOAM FILLED NAVAL SEARCH RADOME	55
33	VENDOR HONEYCOMB RADOME	56

LIST OF TABLES

<u>TABLE</u>	<u>DESCRIPTION</u>	<u>PAGE</u>
3-1	Cost Estimates - Naval Search Radome - Tooling	20
3-2	Cost Estimates - Naval Search Radome	22
3-3	Cost Estimates - Naval Search Radome - Material Costs	23
3-4	Metric Conversion Table	24

CDRL A003
Code Ident 9243
M-24-6-678

1.0 OBJECTIVE

To establish, demonstrate, and document a manufacturing process for fabricating foam filled fiberglass radomes in accordance with appropriate military specifications.

The resultant radomes are suitable for use with land and sea based military radar systems and exhibit a substantial decrease in production costs (20:1) over conventional honeycomb structures coupled with a higher degree of reliability and reproducibility of design.

Superior design performance has also been attained with these radomes in the areas of surface finish, anti-ice formation, thermal insulation, acoustic attenuation, and weight when compared with conventional honeycomb structures. RF transmission loss in foam radomes is greatly reduced from that of honeycomb structures.

CDRL A003
Code Ident 9243
M-24-6-678

2.0 INTRODUCTION

Based on the initial success demonstrated with a fiberglass search and tracking antenna developed by the Advanced Manufacturing Technology area at General Dynamics and now in production on the Navy Phalanx Close-In-Weapon-System, interest was generated in expanding this technology concept into radome development and the consequent production of these radomes as enclosures for these antennas in the Phalanx CIWS.

This has been accomplished with radome production now underway.

Radomes used in conjunction with ship borne and land based radar systems for gun control, target acquisition or the like, are commonly fabricated from honeycomb structures to provide high tensile strength with adequate weight reduction.

Due to the nature of their construction these honeycomb structures require heavy capital outlay such as autoclaves, vacuum systems, and bonding presses along with attendant high tooling and material costs.

In comparison with the 40 inch diameter foam filled polyester glass radome of hemispherical construction contained in this report, which requires no capital outlay or costly tooling, savings of over 20:1 have been realized over conventional honeycomb structures of similar size and geometry.

Although the principal benefit of this program is cost reduction and excellent production capability ease, other factors pertaining to engineering and environmental considerations should be discussed.

Honeycomb structures are prone to delamination due to the bonding area being somewhat less than 30% of the total surface area of the radome. This edge contact bonding in a corrosive atmosphere, high vibrational or thermal stress environment inhibits good bonding integrity and enhances delamination of the facings from the honeycomb substrate.

CDRL A003
Code Ident 9243
M-24-6-678

Surface finish is also poor due to "bleeding" of the honeycomb structure through the facings and the difficulty during manufacture of providing a homogeneous smooth surface for the sphericity required.

This rough and porous surface allows condensation and retention of water vapor which in polar climates allows for rapid ice formation and subsequent attenuation of microwave energy from enclosed radiating elements.

The body of this report will show that the foam filled fiberglass radome prevents ice retention on the exterior surface due to a surface finish of less than 10 micro inches RMS; has excellent RF transmission loss characteristics; will withstand compressive forces of over 5000 lbs/ft²; has superior thermal insulation; and is impervious to corrosion or fungus nutrients.

CDRL A003
Code Ident 9243
M-24-6-678

3.0 ENGINEERING APPROACH AND RESULTS

The initial action taken under the conduct of the program was a task, schedule, and budget review between the Navy Program Monitor and the principal investigator and program manager at General Dynamics. The basic task-schedule plan, as summarized in Figure 3-1, was reaffirmed at that time, but due to tooling mold delays at the vendor facility caused by heavy Spring rains an extension of two months was granted to complete the program.

The basic approach to the development of this type of radome suitable for large production yields was to spin form two aluminum hemispheres built to the outer and inner diameter of the radome dimensions. These hemispheres would serve as master tooling in constructing the fiberglass molds from which the 40" diameter foam filled/fiberglass radome could be produced.

3.1 Spin Forming of Outer Aluminum Hemisphere

Figure 3-2 depicts a sketch of the spin forming operations being performed on one hemisphere. A 60" circular plate of 5/8" thick 6061 aluminum was cut and annealed from the T6 condition to allow easier forming. A center plug on the face of the plate mounts the plate to a hemispherical steel mandrel attached to the head stock of the spin forming lathe. The plate and steel mandrel are then rotated while a constant pressure exerted by a hydraulic ram connected to the tail stock assures firm contact of the aluminum plate to the hemispherical steel mandrel. During rotation of the aluminum plate a circular wheel or roller 12" in diameter and attached to the hydraulic ram applies pressure to the aluminum plate which is being heated with an acetylene torch. Tallow is also hand applied during this operation and provides lubrication to the roller but mainly affords to keep the aluminum plate within temperature limits. Since the tallow burns at a temperature in excess of 700°F removal of the heating torch during tallow ignition keeps the aluminum plate forming between 700° and 800°F.

CDRL A003
Code Ident 9243
M-24-6-678

Ram roller pressure during forming varies and can be as high in this application as 1000 psi during the initial steps of the forming operation and as the final forming steps are completed as low as 10 psi.

Figure 3-3 shows the flat 60" diameter 5/8" thick aluminum plate after annealing and ready for spin forming. Figures 3-4, 3-5, 3-6, and 3-7 illustrate the successive hemispherical forming of the flat aluminum plate.

3.2 Spin Forming Inner Aluminum Hemisphere

As in the outer aluminum hemisphere a 60" diameter circular flat plate, 5/8" thick was formed over the steel mandrel which had been reduced in diameter by 1/2" to facilitate spinning the inner hemisphere to a reduced radius. All operations were identical to those conducted on the outer aluminum hemisphere.

3.3 Attachment of Base Plates to Outer and Inner Aluminum Hemispheres

Both aluminum hemispheres were then conditioned to a T4 hardness before aluminum circular base plates 1.5" thick were welded to each hemisphere. After these operations a center hole 2" in diameter was drilled and tapped through each base to facilitate mounting of each hemisphere to the cutting lathe which would bring each hemisphere to its finished dimension after both had been hardened to a T6 condition.

3.4 Machining of Aluminum Hemispheres

Two cutting templates were provided to the vendor by Advanced Manufacturing Technology to accomplish this task. This would give the outer aluminum hemisphere a diameter of 40.000"±.030" and the inner aluminum hemisphere a diameter of 39.472"±.030".

CDRL A003
Code Ident 9243
M-24-6-678

3.4.1 Sanding and Buffing Operations

The inner aluminum hemisphere on arrival at this facility was then in conjunction with the outer aluminum hemisphere sanded, polished and buffed to a surface finish of less than 10 micro-inches RMS. Both aluminum hemispheres as received from the vendor had a surface finish of $\sqrt{62}$.

3.4.2 Dimensioning of Aluminum Hemispheres

Measurements were then taken on both hemispheres for trueness, diameter, height, and arc. The 40" diameter hemisphere, diameter as measured with an outside caliper read 40.003", and the 39.472" inner hemisphere diameter as measured read 39.479". Since both hemispheres are flat 4.5" above their bases, arc measurement was taken 4.5" up from the base of each radome and was computed from $s = r \theta$

where $s = \text{arc (inches)}$
 $r = \text{radius (inches)}$
 $\theta = \text{radians} = 1.57$

Measurements were done using two templates cut to the arcs required for each hemisphere, the templates fitting into respective center holes at the apex of each hemisphere.

The outer hemisphere measured 31.390" and since $s = r \theta = 20 \times 1.57 = 31.4$ " shows a trueness within .005" and an arc dimension within .010". Height tolerance was within .010" over the 24.5" dimension and measured 24.493".

Inner hemisphere diameter measured 39.479" and was within .007" of the 39.472" correct diameter. Arc dimension as measured read 30.992" and was within .007" of the computed measurements of $s = r \theta = 19.736 \times 1.57 = 30.985$ ". Height tolerance was within .005" and measured 24.240".

CDRL A003
Code Ident 9243
M-24-6-678

Figure 3-8 shows the outer aluminum hemisphere being measured for diameter with an outside caliper, and Figure 3-9 depicts this same measurement on the inner hemisphere. Figure 3-10 illustrates the dimensioning of the arc of the 40" hemisphere from a measuring tool fabricated by Advanced Manufacturing Technology. Figure 3-11 shows the two aluminum hemispheres polished to a 5 micro inch finish. Figure 3-12 illustrates a 40" diameter foam/fiberglass radome of the type which will be taken from the two aluminum masters after mold fabrication has been completed.

3.4.3 Mold Construction - Outer Concave Mold Assembly

The 40" diameter aluminum hemispherical plug was waxed and polished before a spray coat (.015" nominal thickness) was applied over the plug. This gel coat was black in color and provides a close visual inspection of the mold for flaws and irregularities on removal of the aluminum plug. Figure 3-13 illustrates the application of the black gel coat.

After cure of the gel coat (room temperature-minimum 4 hours) a hand lay-up of 1 oz. mat and polyester resin (2 layers) was applied in quadrants over the outer radome plug and after air removal from the resin/glass cloth matrix by teflon rollers the lay-up was allowed to cure for 24 hours at room temperature. This step adds additional strength to the mold and would enhance the durability of the mold in a production mode.

Successive applications of sprayed fiberglass chop were then added to the radome to an overall thickness of 3/4", each application being approximately 1/8" to 3/16" thick and being allowed to cure for a minimum of 24 hours before the next application. This is done to prevent large exothermic reactions taking place during polymerization of the resin which could distort the mold if not controlled. Also during this period two layers of 1 oz glass mat were hand applied to the base of the chopped glass mold to ensure further structural integrity of the mold on removal of the aluminum plug, and also to eliminate the possibility of non-sphericity during this operation. Figures 3-14, 3-15, and 3-16

CDRL A003
Code Ident 9243
M-24-6-678

depict the application of the chopped fiberglass and base lay-up of 1 oz mat and also show the removal of air and excess resin by hand rolling with steel and teflon rollers.

3.4.3.1 Supporting Structure

After completion of the fiberglass mold operations over the aluminum plug, a supporting structure consisting of a wooden table, legs, braces, and 5" diameter caster wheels was mounted to the hemispherical radome mold containing the aluminum plug. Figure 3-17 illustrates the fiberglass mold being "glassed in" to the table top before the addition of the braces, legs, and casters to complete the outer mold structure. This was done after it was assured that the fiberglass dome structure containing the outer aluminum hemisphere was perpendicular to the table surface. Figure 3-18 shows the supporting structure which will accept the table top and fibreglassed outer aluminum hemisphere.

Before removal of the aluminum hemisphere the protruding lip of the fiberglass mold was further strengthened with glass as was the top side of the table. This gave a total thickness of 1" to the peripheral base of the outer mold assembly. Figure 3-19 illustrates this condition and also shows the aluminum hemisphere connected to a 1/2 ton manual hoist. At the right of the figure the circular wooden section is shown which was cut from table top center before installation and glassing of the fiberglass mold encasing the aluminum hemisphere.

3.4.3.2 Oven Cure of Outer Mold Assembly

To assure a complete cure of the fiberglass structure encasing the outer aluminum hemisphere and to prevent out of tolerance conditions arising at a future date due to fiberglass shrinkage, the assembly was cured in a large walk in oven for 8 hours at 160°F before being removed from the oven and allowed to cool to room temperature before further assembly operations were conducted.

3.4.3.3 Removal of Aluminum Hemisphere from Outer Mold Assembly

Utilizing an upward force exerted by the manual hoist and a series of air nozzles directing compressed air (100 psi) between the mold assembly, the aluminum hemisphere was removed from the mold assembly. Figures 3-20 and 3-21 show this operation.

As can be observed from Figure 3-21 the outer aluminum hemisphere has an excellent surface finish which is imparted to the inner surface of the outer mold assembly.

3.4.3.4 Enclosing Outer Mold Assembly with Aluminum Sheeting

After examination of the inner surface of the outer mold assembly for gel coating irregularities the mold was enclosed on four sides with aluminum sheeting which had been painted navy grey. The table top was also covered with .060" thick aluminum sheeting. This is shown in a later figure.

3.4.3.5 Diameter and Height Measurements of Outer Mold Assembly

Using a large caliper, the diameter of the inner surface of the outer mold assembly was measured at 45° spacings and read as follows, 39.993", 39.993", 40.001" and 40.003", which gave a tolerance from the nominal dimension of 40.000" of +.003 - .007. Height measurement taken from a steel rod placed exactly at the center of the apex of the hemisphere and perpendicular to it measured 24.491" which was .002" under that measured on the height of the outer aluminum hemisphere. These excellent results show the feasibility of this manufacturing process.

3.4.4 Inner Mold Assembly

Simultaneous operations were conducted on the inner aluminum hemispherical plug (39.472" diameter) during the outer mold construction as is shown on some of the figures explained in the construction of the outer mold assembly.

CDRL A003
Code Ident 9243
M-24-6-678

Previously, in the second quarterly report, it had been stated that the inner aluminum plug would be used as a mold, and that direct lay-up of the inner facing of the finished radome would be taken from this aluminum plug. This, although feasible, would mean that the inner aluminum plug would be exposed to damage (scratches, abrasions, etc.) during handling and facing lay-up operations, and it was decided that a fiberglass mold identical in shape and dimension to the inner aluminum hemisphere would be constructed and would serve as the inner mold. The inner and outer aluminum hemispheres would then be retained as masters from which future fiberglass molds could be drawn when required for large production needs.

3.4.4.1 Diameter and Height Measurement of Inner Mold Assembly

After removal of the inner aluminum hemisphere from the inner mold assembly in steps identical to those explained on the outer mold assembly measurements were taken as to the diameter of the inner mold assembly at its base. At 45° spacings readings were 39.470", 39.474", 39.465", and 39.466", giving a tolerance of +.005 - .014 from the measured dimension of 39.479" of the inner aluminum hemisphere.

Height measurement read 24.235 and was .005" under the height measurement of the aluminum hemisphere.

3.4.5 Inner Plug Fabrication

After waxing and buffing the concave interior of the inner fiberglass mold, a spray coating of black gel coat was applied to this surface to a thickness of .010" to .015" and allowed to cure at room temperature from 2 to 4 hours. This was followed with a hand lay up of 2 layers of 6 oz glass cloth and an additional 2 layers of 1 oz mat, each layer being resined and allowed to polymerize, after air and excess resin had been removed by rollers and squeegees. Successive layers of chopped glass were then applied over this surface to a thickness of 1/2", each application being approximately 1/8" thick and allowed to cure for 24 hours before the next layer was "chopped" on. Again as in the outer mold

CDRL A003
Code Ident 9243
M-24-6-678

assembly this was done to prevent high exothermic reaction of the resin distorting the mold symmetry.

3.4.5.1 Strengthening of Inner Fiberglass Plug

Into the interior of the plug wooden braces (2 x 4's) were "glassed in" with 1 oz mat and resin and allowed to cure at room temperature. Over this and around the periphery of the base a circular wooden frame approximately 38.9" in diameter, 1/2" thick and 6" in width was bonded with glass mat and resin to the inner surface of the fiberglass plug. This operation was allowed a 24 hour room temperature cure.

3.4.5.2 Eye Bolt Insertion

The wooden braces were then drilled to accept 2-3/8" ID eye bolts which when connected to steel guy wires to the hoist would raise and lower the inner plug assembly mating with the outer mold assembly.

3.4.5.3 Oven Cure of Inner Plug Assembly

Again as was done in the outer mold assembly containing the outer aluminum hemisphere, the inner mold assembly containing the inner plug assembly was cured in a large oven for 8 hours at 160°F, to prevent future shrinkage and mold distortion of the inner plug. Upon removal from the oven the two assemblies were allowed to cool to ambient temperature before the inner plug was removed from the inner mold as similarly shown in Figures 3-19, 3-20, and 3-21 where the outer aluminum hemisphere was removed from the outer mold assembly.

Figure 3-22 shows the inner fiberglass plug being removed from the inner mold assembly and the excellent surface finish obtained.

3.4.5.4 Diameter and Height Measurement of Inner Plug

Diameter measurements taken at 45° spacings read 39.465", 39.463", 39.460", and 39.458 well within the ±.030" tolerance allowed on the diameter of the inner plug.

CDRL A003
Code Ident 9243
M-24-6-678

Height measurement read 24.228" and was only .008" from the nominal dimension of 24.236" and .012" under the measured height of the inner aluminum hemisphere of 24.240".

19" Diameter Radome Window

Also during this period of inner mold assembly a 19" diameter hemispherical foam/fiberglass radome window was manufactured from tooling constructed by Advanced Manufacturing Technology for initial tests on this type of radome structure for the Phalanx Ship/Gun System.

The 19" radome, identical in construction with the 40" diameter radome in its facings and foam core, has facing thicknesses of .035" and a foam core of $\approx .200$ ".

It was stated in a previous quarterly report that this smaller radome window would be crushed in a tensilometer to determine the compressive buckling force and the results extrapolated (force vs deflection) to that of a 40" dia. radome.

Advanced Manufacturing Technology during the initial development of the Phalanx radome window had conducted this test which was accepted by the Phalanx Program Office as valid. This test which gives a close indication of structural integrity and which assures that a 40" diameter radome could accept a loading force of 500 lbs/ft² does not determine the isostatic force which would be a more precise condition. Consequently this test will not be run on the 19" radome but a 40" diameter radome will be tested in the following manner.

The radome will be mounted on a vacuum table and sealed, and a partial vacuum impressed on the interior of the radome. Pressure to the interior of the dome will be reduced from 1 atmosphere to 6.7 lbs/in² which will impress an isostatic force of 1152 lbs/ft² (8 psi) to the exterior of the radome. This would be an ample indication that the radome could withstand the C.I.W.S. (Phalanx) specification of 500 lbs/ft².

CDRL A003
Code Ident 9243
M-24-6-678

Figure 3-23 depicts the 19" diameter foam filled fiberglass radome with a surface finish of less than 5 micro-inch RMS. As explained in previous reports Advanced Manufacturing Technology had striven for this excellent nonporous finish to inhibit ice formation on the surface of the dome during operation in polar regions.

3.5 Inner and Outer Mold Assembly

Figure 3-24 illustrates the method of joining the inner plug and outer mold during the fabrication of the naval search radome. A hooking eye fastened to the convex inner mold is attached to a 1/2 ton manual hoist. Over the inner mold a circular steel ring has been bolted. This assures a seal between the inner plug and outer mold during foaming. It also contains a series of 1/8" diameter holes equally spaced through the ring which provide escape of the foam and gases during foaming of the assembly. Bolted to the table top are four equally spaced guide pins which prevent the top inner plug from lateral movement during its closure into the concave outer mold. The concave outer mold is held stationary by having the wheel casters locked by a braking mechanism. Also spaced around the top of the outer mold assembly is a series of 12 clamps which when locked over the steel ring of the inner plug prevent movement of the inner plug during the foaming operation.

The inner plug and outer mold shown provide not only the foam assembly tool but also the molds from which the outer and inner skin facings are layed up. Figure 3-24 does not show the outer and inner facings layed up over the appropriate outer concave mold assembly and inner convex plug assembly.

3.5.1 Template Design for Glass Cloth Lay Up

To provide a sound method of construction both structurally and to effect an identical part each time, a method was devised to provide cutting the glass cloth in quadrants with some overlap to each quadrant during layup. This was accomplished by fabricating two flat templates.

CDRL A003
Code Ident 9243
M-24-6-678

The two templates were constructed from .062" thick aluminum flat stock and would be utilized to cut both the inner and outer glass cloth for the inner and outer facings of the search radome.

One template would consist of a quarter of a flattened hemispherical triangle cut to the dimensions required and allowing for some overlap as the glass cloth was layed up with resin over the hemispherical mold. In addition the top of the aluminum template would have a circular cut out to allow for the addition of the cap piece fitting over the dome and cut from the second template.

The second circular template would consist of a 20" diameter flat piece of aluminum .062" thick. This also allowed for some overlap where it met the four pieces of glass cloth layed up in quadrants.

The cloth in question is 4 oz. glass cloth and consists of a resined double layer of cloth, the two cap pieces fitting over the apex of the dome and 8 pieces (1 for each quadrant) off set from each other forming the major portion of the dome.

Figure 3-25 shows an illustration of the foam fiberglass radome. Length of the arc from the apex of the dome to the base of the hemisphere would be

$$\begin{aligned} S &= r \theta \ (\theta \text{ in radians}) \\ &= 20 \times \frac{90}{57.3} = 31.4" \end{aligned}$$

Since a flat portion 4.5" in height extends below the hemisphere, the total length of the arc plus the straight portion would be 35.9". Allowing for some overlap this dimension was increased to 36.25".

CDRL A003
Code Ident 9243
M-24-6-678

Figure 3-26 shows three cords which are radii generated at each of the vertices of the flattened spherical triangle (1 quadrant). Again from Figure 3-26 the flattened arc would have to be

$$S = r \theta$$
$$= 36.25 \times \frac{60}{57.3} = 37.95"$$

Figure 3-27 illustrates the flattened quadrant template with the apex generating a 9" radius cut from the template. Again allowing for overlap when the cloth was layed up Figure 3-28 shows the circular template cut on a 10" radius.

Figures 3-29 and 3-30 show respectively the actual aluminum templates used for the glass cloth/resin lay up of the constructed radomes.

3.5.1.1 Inner Facing Fabrication

Using the templates previously described 4 oz. glass cloth was cut to provide 8 glass cloth quadrants and 2 glass cloth circles which would fit over the apex of the inner radome convex plug.

The inner plug was spray gel coated with a .010" thick white gel coat after the plug had been waxed and polished. After polymerization of the gel coat the glass cloth quadrants were layed up over the plug with brush applied polyester resin and overlapped. A second set of quadrants were then layed up and resined, being off set 1/2" from the original glass cloth quadrants. The cap pieces were then applied and brush coated with resin before the whole glass cloth/resin assembly had excess resin removed by squeegee. Excess glass and resin appearing over the edge of the plug during lay up was trimmed from the periphery of the plug with a box knife before complete cure of the inner facing was effected. Total thickness of facing including gel coat was approximately .035" and had a tolerance on this dimension of +.010 -.005".

3.5.1.2 Outer Facing Fabrication

The outer facing or shell was accomplished by spray coating the highly polished waxed surface of the outer concave mold with a .010" thick white gel coat. After polymerization of the gel coat, the glass cloth was applied over this surface in identical operations as to the inner facing fabrication.

3.5.2 Hard Point Fabrication

To provide hard points to the finished radome for mounting carrying handles and also the latch mounts connecting the radome to the servo structure, a series of holes 1/8" in diameter were drilled through the outer concave mold at the required locations.

3.5.2.1 Teflon Spacer Attachment

After lay up and cure of the outer glass facing in the concave mold, the holes in the mold were used to drill through the facing for attachment of .190" thick teflon spacers by means of 1/8" diameter dowel pins.

The curved teflon spacers serve two important functions:
(1) provide concentricity between the inner and outer molds containing the glass facings during closure of the molds and
(2) provide the hard points for the radome. These teflon spacers are removed after foaming, the voids being filled with a resin/milled fiber compound which bonds to the inner and outer facing to form strong attachment points. After teflon placement, the inner plug and outer mold now containing the inner and outer glass facings were ready for the foaming operation.

3.5.3 Foaming Operation

Into the concave outer mold containing the outer facing, 6 lbs of 2 lb/ft³ free rise foam (polyurethane) were poured. (Computations showed that approximately 3 lbs of foam would be required to fill the .193 ft³ of volume when mold closure was achieved. Excess foam would appear and be vented through the vent

CDRL A003
Code Ident 9243
M-24-6-678

holes provided.) After foam pour, the inner plug containing the inner facing was lowered by hoist into the outer mold and clamped in place with a series of clamps spaced around the periphery of the outer mold. After a 4 hour cure at 160°F in a large convection oven the assembly was removed and allowed to cool to room temperature before the inner plug and radome were removed from the outer mold assembly with pressurized air. The foam filled radome is then removed from the inner plug with pressurized air.

Figure 3-31 shows the mold assembly after curing of the foam. The excess foam from the vent holes has been removed prior to removal of the steel ring, and the removal of the inner mold and radome from the outer mold assembly, by means of the hoist and a high pressure air gun.

3.6 Completed Radome Window

Figure 3-32 shows the completed foam-filled 40" diameter naval search radome. The teflon spacers have been removed and the voids filled with a fiberglass/resin mix bonding the inner and outer facings of the radome. After cure, the holes were enlarged to the proper dimensions for latch and handle attachment. A thin layer of a polyurethane elastomer was also brush coated along the base of the naval search hemisphere to provide a seal to the foam interface. Although the foam is of a closed cell structure, the addition of the elastomer prevents any wicking of moisture at the base of the radome.

3.7 Vendor Honeycomb Radome Window

Figure 3-33 illustrates the vendor honeycomb design, with handles and latches in place. It shows peeling of the Tedlar coating encasing the outer surface of the radome and would be a source of water vapor retention and absorption at these points. The hemispherical geometry is greatly irregular and the honeycomb structure has "bled through" the epoxy glass facings. In the past removal of ice from this radome in a cold environment could not be accomplished without serious damage to the radome. Also, since

CDRL A003
Code Ident 9243
M-24-6-678

epoxy glass facings support fungus growth, the complete inner surface of the radome and the outer portions where the Tedlar coating is removed would be susceptible to fungus contamination.

3.8 Foam Machine

A foam machine with a flow capacity of 60 lbs/minute has been purchased from a vendor and is now in operation at this facility. The purchase of this foam machine has assured a smooth production flow on the radomes of the Phalanx C.I.W.S.

The present method of mixing with a pressurized air stirrer the A and B components of the 3 lb/ft³ free rise polyether foam in a bucket, and pouring the 6 lbs of foam over the inner surface of the outer facing of the outer radome mold before closure of the inner plug is not conducive to production needs. Although this method has produced excellent search radomes, a time factor is critical in performing the operations required before cream time of the foam takes place. (Cream time is the time it takes after mix for foam expansion to occur.) At this time foam injection must cease.

With a 15 second foam mix, cream time occurs 30 seconds later. This means that pour time, plus mold closure, plus clamping, can have a duration of only 30 seconds. Lowering the 250 lb inner plug containing the inner facing by utilizing the 1/2 ton manual hoist must be accomplished rapidly and with precision. Clamping of the molds together must then take place.

Since pour time takes 4 seconds, mold closure 12 seconds and clamping 5 seconds, this leaves only 9 seconds until cream time occurs.

Utilizing a foam machine, foam can be injected through the apex of the inner plug and facing with the molds in a clamped and closed position. The foam machine will also meter the amount of foam injected so that the proper restrained density required can be achieved each time.

CDRL A003
Code Ident 9243
M-24-6-678

Flow rate can be calculated as follows:

$$\text{Flow Rate (lbs/min)} = \frac{\text{Mold Volume (ft}^3\text{)} \times \text{Molded Foam Density (lbs/ft}^3\text{)}}{\text{Cream Time (min)}}$$

Since the foam machine in question has a cream time of .25 minutes using the 2 lb/ft³ free rise foam, flow rate for the naval search radome would be,

$$\text{Flow Rate} = \frac{.293 \times 8.6}{.25} = 10 \text{ lbs/min}$$

The foam machine purchased which can meter and pump 60 lbs/minute of 2 lb/ft³ foam gives adequate mix and pour times before cream rise takes place.

3.9 Cost Analysis

Attached to the following sheets is a comprehensive list of material and labor costs for the tooling on the naval search radome, along with the material and labor costs for the fabrication of the naval search radome.

Cost of the vendor honeycomb radome was \$5993.00 against the foam core radome of \$307.85, a cost reduction of nearly 20:1. Tooling costs for the naval search radome was also less and had a figure of \$15,424.13 compared with the vendor tooling cost of \$22,350.00.

CDRL A003
Code Ident 9243
M-24-6-678

TABLE 3-1

Cost Estimates - Naval Search Radome

<u>Part</u>	<u>Tooling</u>		<u>Total Cost</u>
	<u>Material Cost</u>	<u>* Labor Cost (\$)</u>	
Outer Aluminum Hemisphere (Vendor Part)	---	---	\$ 5,540.00
Inner Aluminum Hemisphere (Vendor Part)	---	---	\$ 5,540.00
Steel Cutting Templates (2)	\$ 27.00	\$ 504.00	\$ 531.00
<u>Outer Mold Assembly</u>			
Outer Fiberglass Mold (Vendor)	\$231.50	\$ 698.00**	\$ 929.50
Table Structure	\$ 63.18	\$ 90.00	\$ 153.18
Aluminum Sheeting on Table Structure	\$ 59.36	\$ 36.00	\$ 95.36
Casters (4) 5" Diameter	\$ 52.00	\$ 18.00	\$ 70.00
Clamps and Height Blocks (12)	\$ 96.00	\$ 54.00	\$ 150.00
Teflon Inserts	\$ 5.00	\$ 72.00	\$ 77.00
Guide Pins (4)	\$ 8.00	\$ 54.00	\$ 62.00
Dowel Pins (18)	\$ 3.95	---	\$ 3.95
Assorted nuts and bolts	\$ 5.25	---	\$ 5.25
<u>Inner Mold Assembly</u>			
Inner Fiberglass Mold (Vendor)	\$205.25	\$ 674.00	\$ 879.25
Table Structure	\$ 63.18	\$ 90.00	\$ 153.18
Casters (4) 5" Diameter	\$ 52.00	\$ 18.00	\$ 70.00
Assorted nuts and bolts	\$ 4.00	---	\$ 4.00
	\$875.67	\$2,308.00	\$14,263.67

CDRL A003
Code Ident 9243
M-24-6-678

TABLE 3-1 (continued)
Cost Estimates - Naval Search Radome

<u>Part</u>	<u>Tooling</u>		<u>Total Cost</u>
	<u>Material Cost</u>	<u>*Labor Cost</u>	
<u>Inner Plug Assembly</u>			
Inner Fiberglass Plug (Vendor)	\$181.55	\$ 636.00	\$ 817.55
Supporting Battens	\$ 4.00	\$ 9.00	\$ 13.00
Eye Bolts (4)	\$ 12.00	\$ 18.00	\$ 30.00
Hoist (1/2 ton manual)	\$128.00	\$ ---	\$ 128.00
Steel Foaming Ring	\$ 78.41	\$ 72.00	\$ 150.41
Bolts and Nuts	\$ 21.50	\$ ---	\$ 21.50
	\$425.46	\$ 735.00	\$ 1,160.46
		GRAND TOTAL	\$15,424.13

*Based on an \$18./hr rate

**Based on a \$20./hr rate

CDRL A003
 Code Ident 9243
 M-24-6-678

TABLE 3-2

Cost Estimates - Naval Search Radome

<u>Operation</u>	<u>Time (Hr)</u>	<u>Labor Cost (\$18./Hr.)</u>
Buff and wax molds	0.5	\$ 9.00
Gel coat molds	1.0	18.00
Lay up inner and outer facings over molds	3.5	63.00
Trim after cure	0.17	3.00
Sand and clean inner and outer facings	0.6	10.80
Drill and secure teflon spacers (14) with steel dowell pins	0.6	10.80
Attach steel foaming ring to inner plug	0.2	3.60
Position inner plug over outer mold	0.15	2.70
Mix required weights of #6502 A&B foam components	0.17	3.00
Pour foam into outer mold cavity and effect closure of assembly		
Remove radome from molds after oven cure	1.25	22.50
Drill 18 holes through inner facing	0.33	6.00
Remove teflon inserts and remove foam residue from facings	1.25	22.50
Tape over tooling holes	0.17	3.00
Pour hardpoints after resin/fiber preparation	1.0	18.00
Sand flush with base of radome after cure	0.5	9.00
Apply 1.25" wide band of fiberglass to inner surface at base of radome	1.0	18.00
Redrill tooling holes to drawing dimensions and countersink	1.25	22.50
Chamfer edge of base of radome	0.75	13.50
Seal base of radome with Polyurethane elastomer after mix preparation	0.5	9.00
	14.89	\$267.90

CDRL A003
Code Ident 9243
M-24-6-678

TABLE 3-3
Cost Estimates - Naval Search Radome
Material Costs

<u>Part</u>	<u>Material Cost</u>
4 oz Glass cloth (9 yards)	\$ 9.81
Resin (2 quarts)	2.50
MEK Peroxide	.10
Gel Coat (2 quarts)	1.70
Polyurethane Elastomer (1 pint)	6.00
Milled Fibers (1/2 lb.)	.32
Foam #6502 (6 lbs)	15.00
Acetone (1 gal)	1.02
Waxes and buffing compounds	<u>3.50</u>
	\$ 39.95
 Total Cost of Radome	 \$307.85

TABLE 3-4
Metric Conversion Table

<u>English Units</u>	<u>Metric (SI) Units</u>	<u>Conversion Factor</u>
Given	To Obtain	Multiply by
<u>Length</u>		
Inch (in)	Meter (m)	2.540×10^{-2}
Foot (ft)	Meter (m)	3.048×10^{-1}
<u>Area</u>		
Inch ² (in ²)	Meter ² (m ²)	6.452×10^{-4}
Foot ² (ft ²)	Meter ² (m ²)	9.290×10^{-2}
<u>Volume</u>		
Inch ³ (in ³)	Meter ³ (m ³)	1.639×10^{-5}
Foot ³ (ft ³)	Meter ³ (m ³)	2.832×10^{-2}
<u>Force</u>		
Pound (lb)	Newton (N)	4.448
<u>Mass</u>		
Slug	Kilogram (Kg)	1.459×10^1
<u>Pressure</u>		
lb/in ² (psi)	Pascal (Pa)	6.895×10^3
lb/ft ²	Pascal (Pa)	4.882
in of Hg (60°F)	Pascal (Pa)	3.377×10^3
<u>Torque</u>		
in. lb	Joule (J)	1.130×10^{-1}

CDRL A003
Code Ident 9243
M-24-6-678

TABLE 3-4 (continued)
Metric Conversion Table

<u>English Units</u>	<u>Metric (SI) Units</u>	<u>Conversion Factor</u>
Given	To Obtain	Multiply by
<u>Temperature</u> °F	°C	$(T_{\text{F}} - 32)/1.8$
<u>Thermal Conductivity</u> BTU in/hr ² Ft ² °F	cal-cm/sec-cm ² .°C	2.923×10^3
<u>Density</u> lb/in ³ lb/ft ³ oz/yd ³	Kg/m ³ Kg/m ³ Kg/m ³	2.768×10^4 1.602×10^1 3.391×10^{-2}
<u>Flow Rate</u> lb/min	Kg/s	7.560×10^{-3}

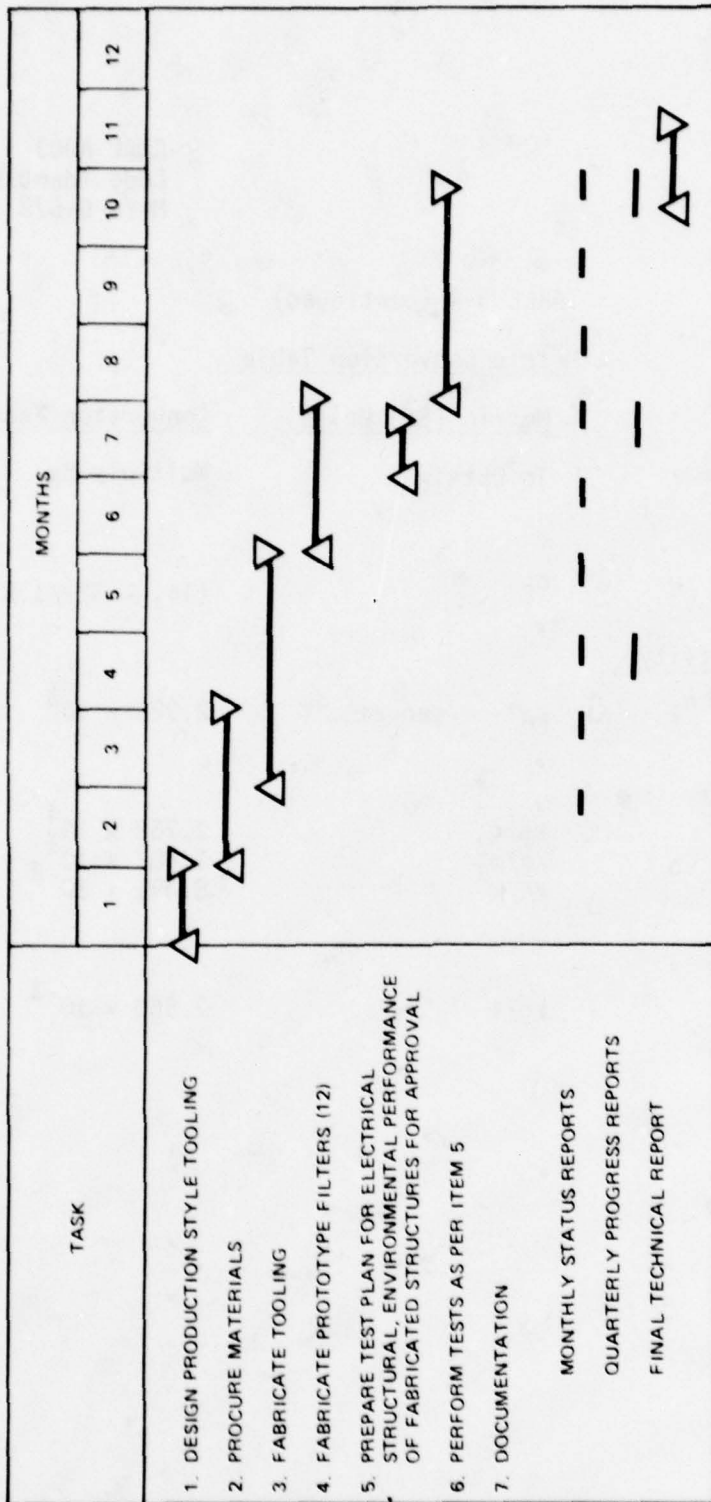

R207521 719

Figure 3-1. Program Conduct

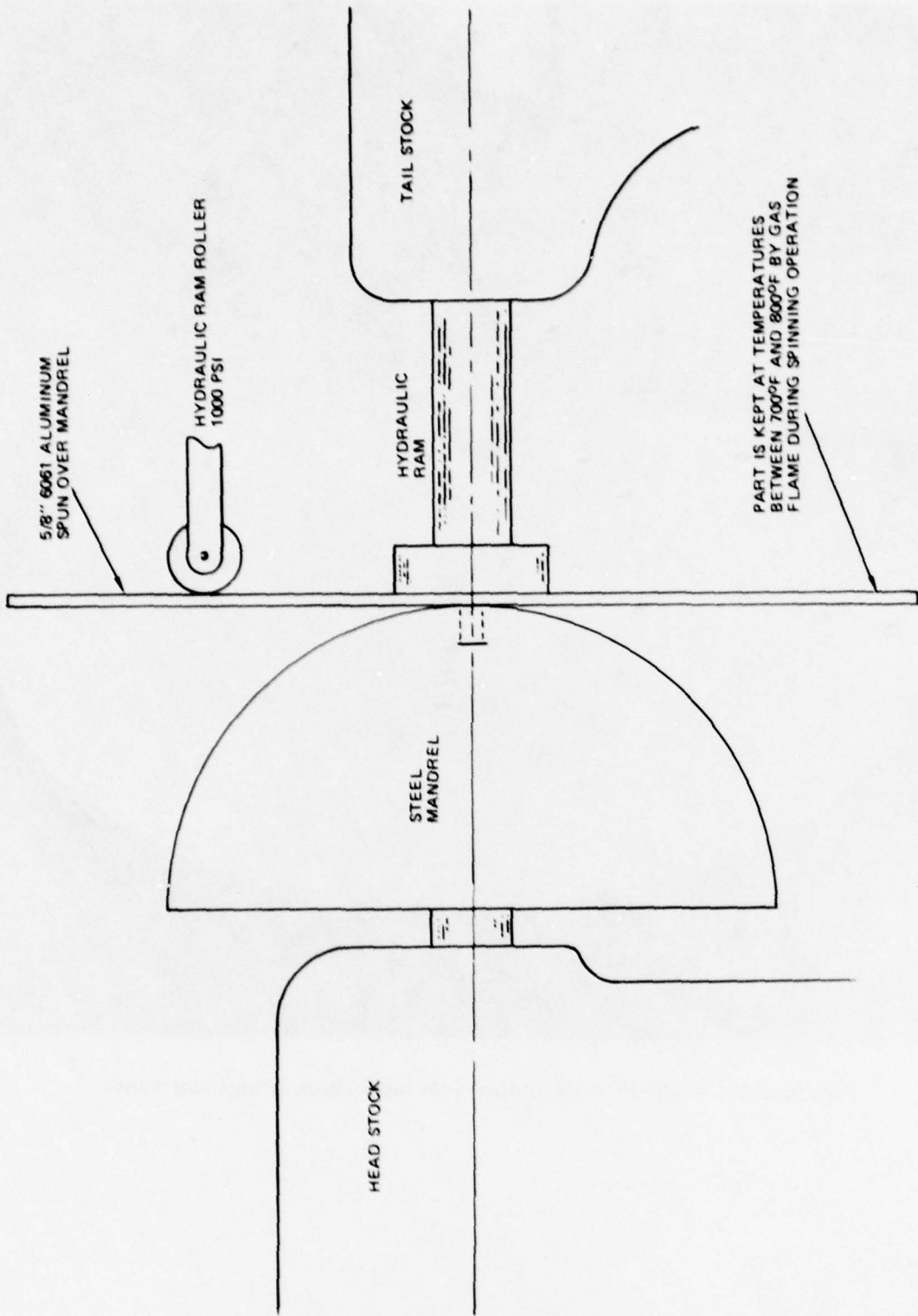

PART IS KEPT AT TEMPERATURES BETWEEN 700°F AND 800°F BY GAS FLAME DURING SPINNING OPERATION

Figure 3-2. Spin Forming of a 40-Inch Diameter Naval Aluminum Hemisphere

R207433 719

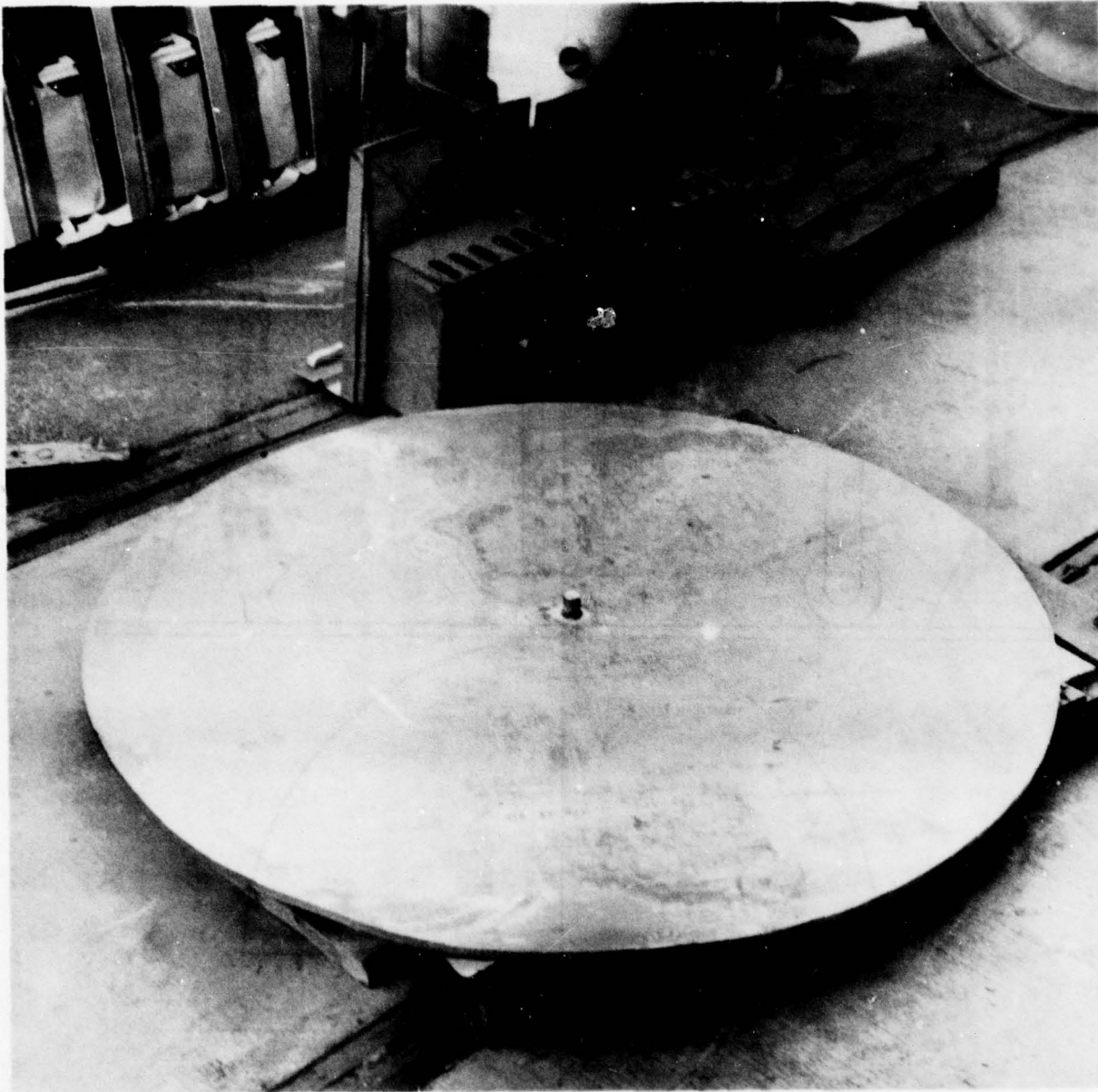

A207434

Figure 3-3. Sixty-Inch Diameter 5/8-Inch Thick Aluminum Plate



A207435

Figure 3-4. Spin Forming 60-Inch Diameter Aluminum Plate

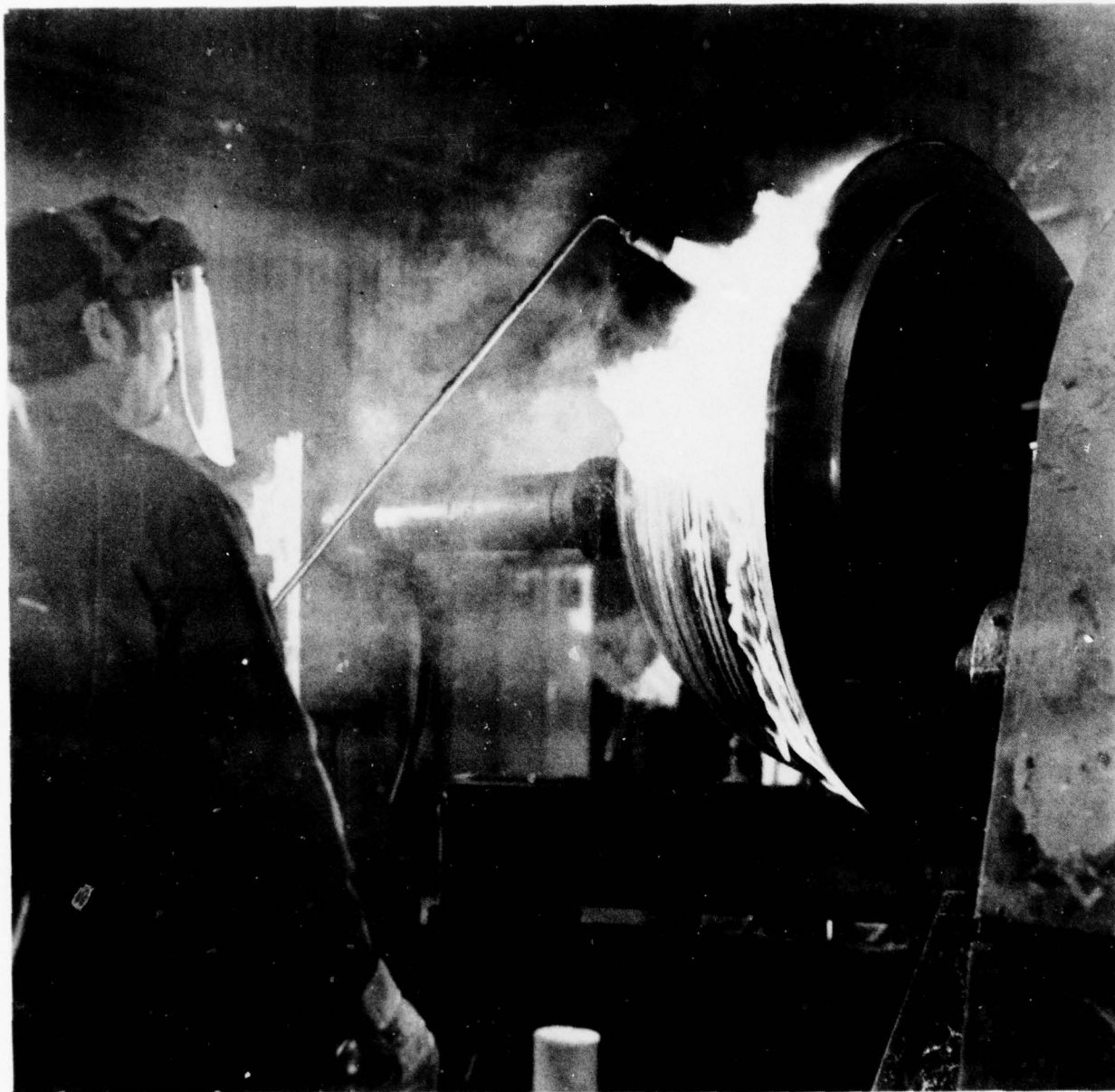

A207437

Figure 3-5. Spin Forming 60-Inch Diameter Aluminum Plate

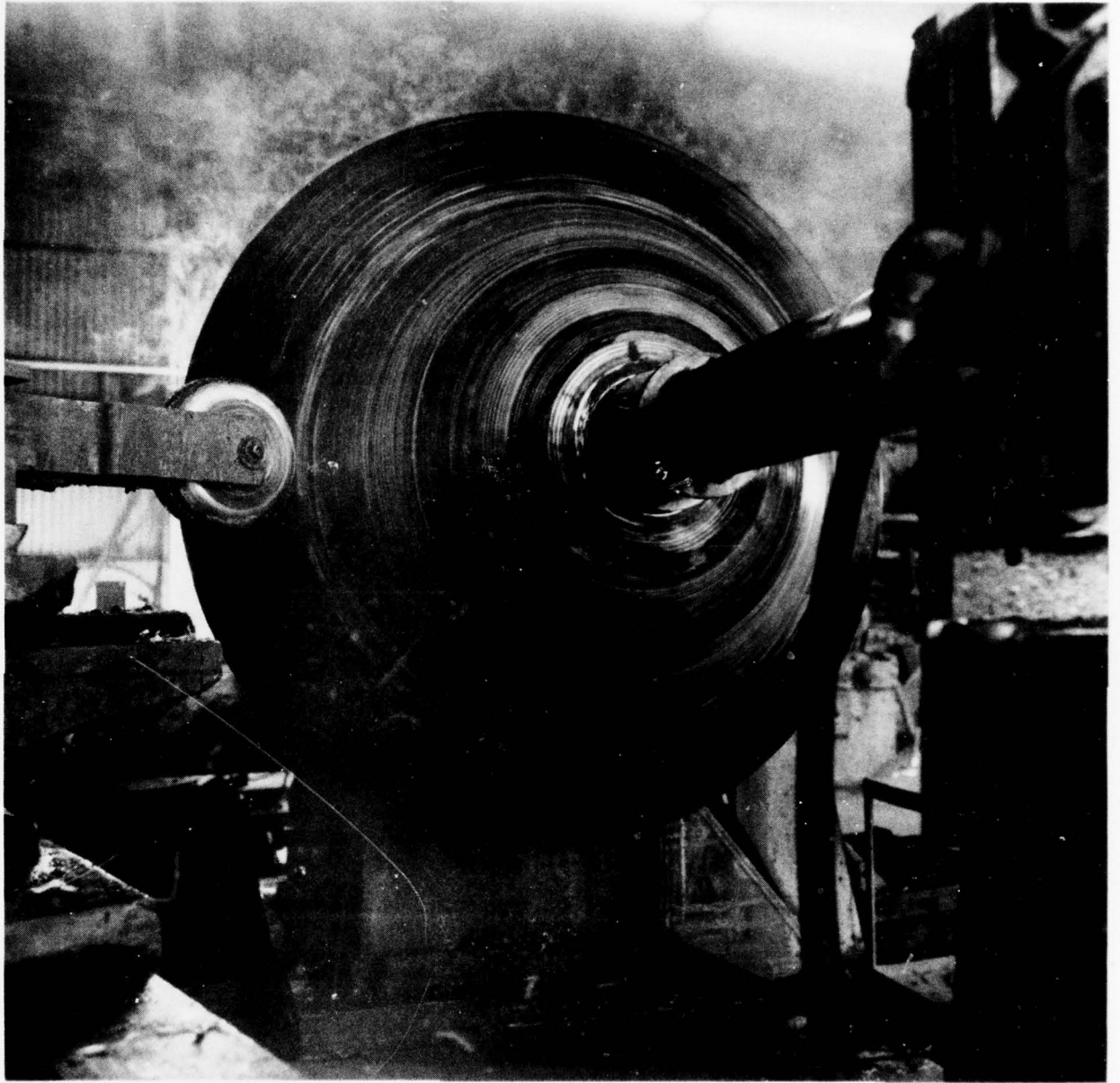

A207438

Figure 3-6. Spin Forming 60-Inch Diameter Plate

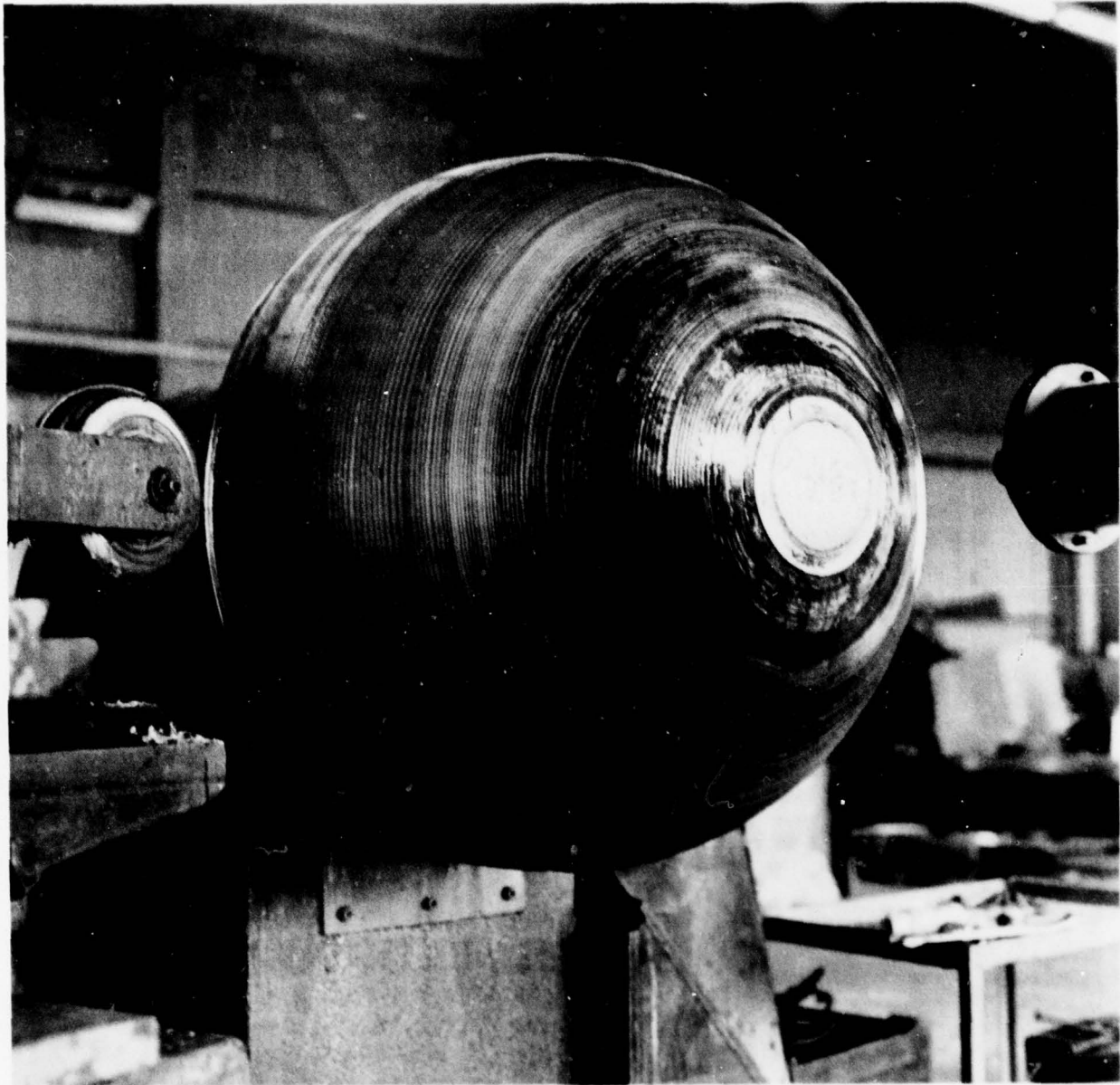

A207419

Figure 3-7. Completed Spun Formed Aluminum Plate
Into 40-Inch Diameter Hemisphere

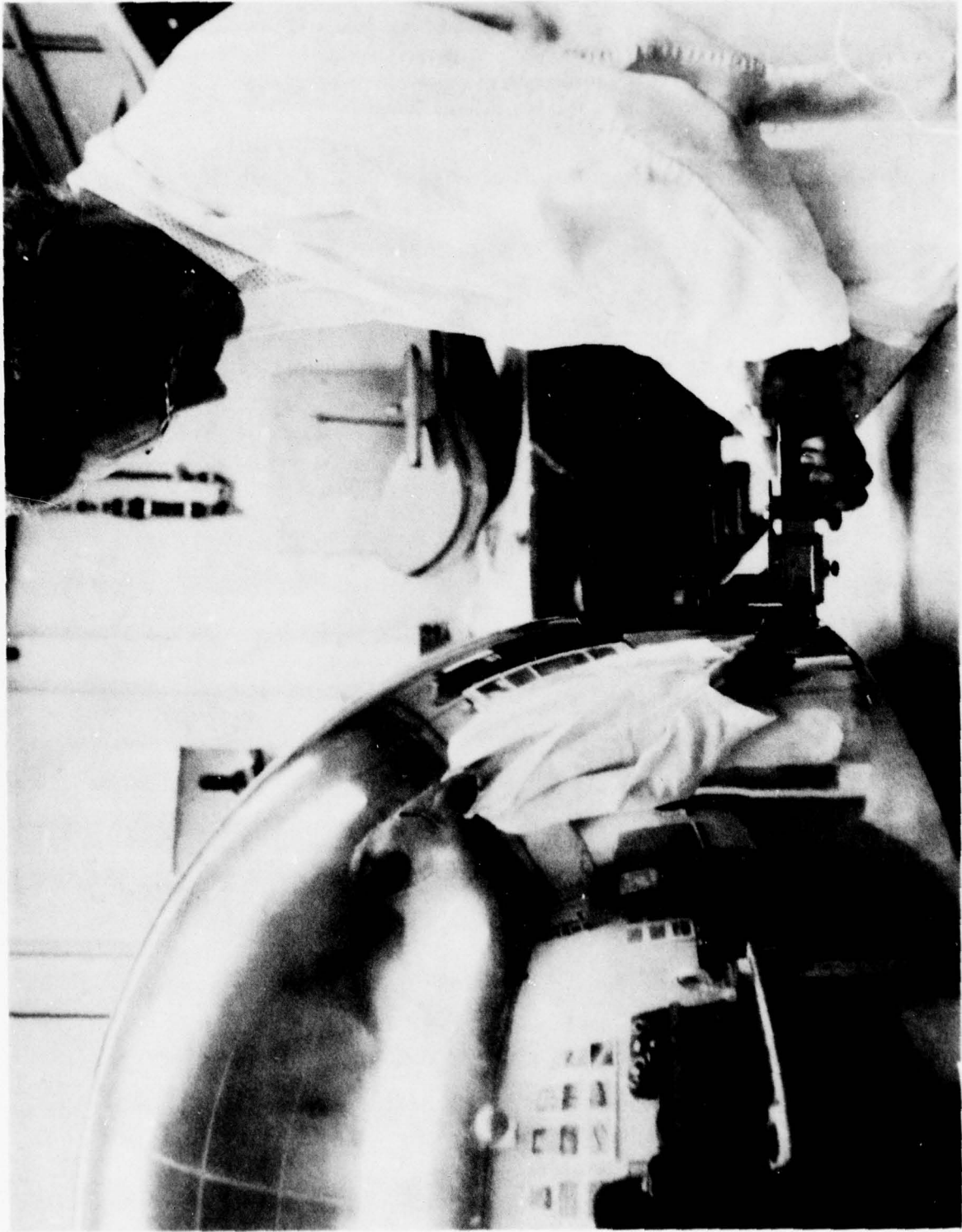

Figure 3-6. Measuring Diameter of 40-Inch Naval Aluminum Hemisphere

A207440



Figure 3-9. Measuring Diameter of 39.472-Inch Naval Aluminum Hemisphere

A207441

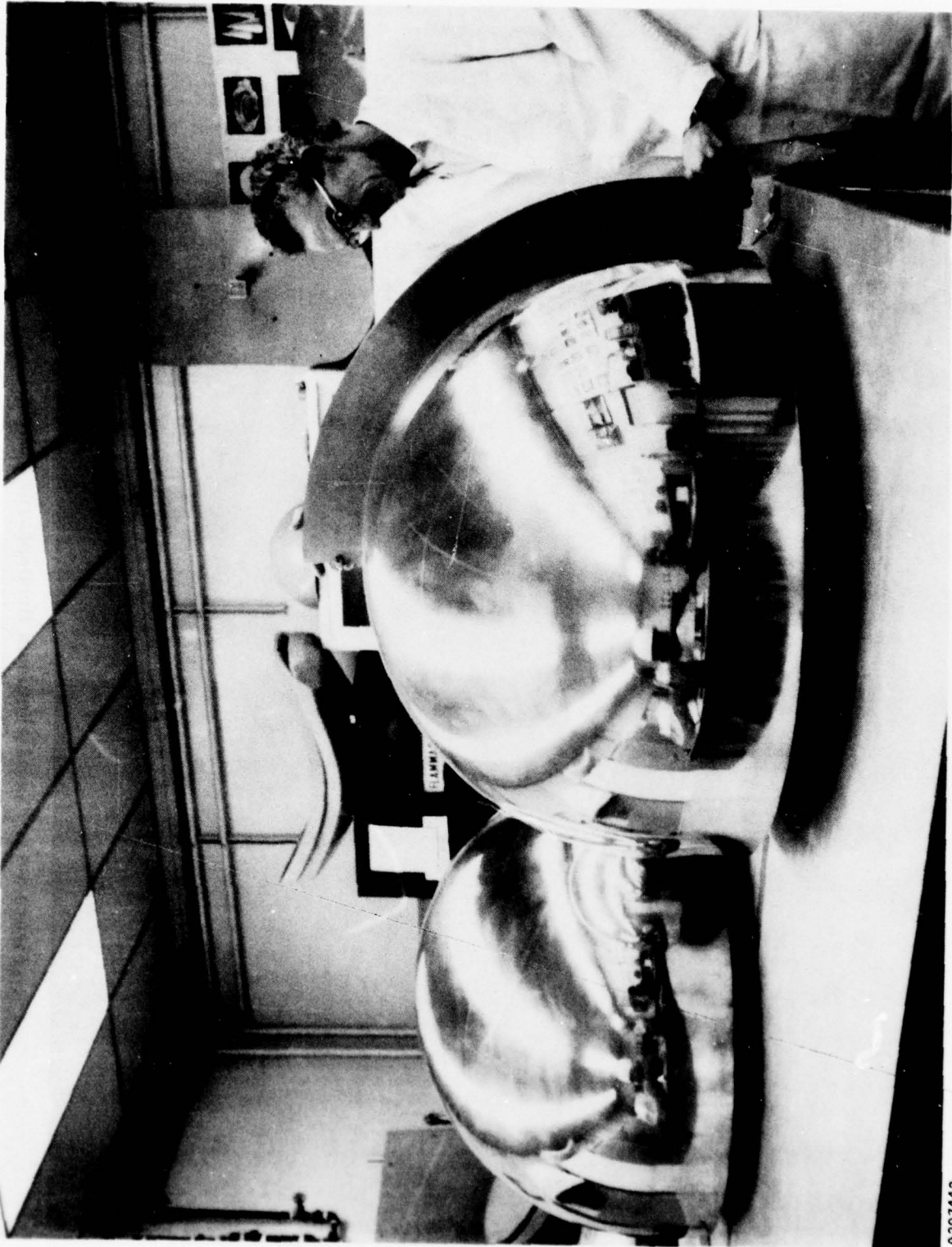

Figure 3-10. Dimensioning of the Arc of a 40-Inch Naval Aluminum Hemisphere

A207442

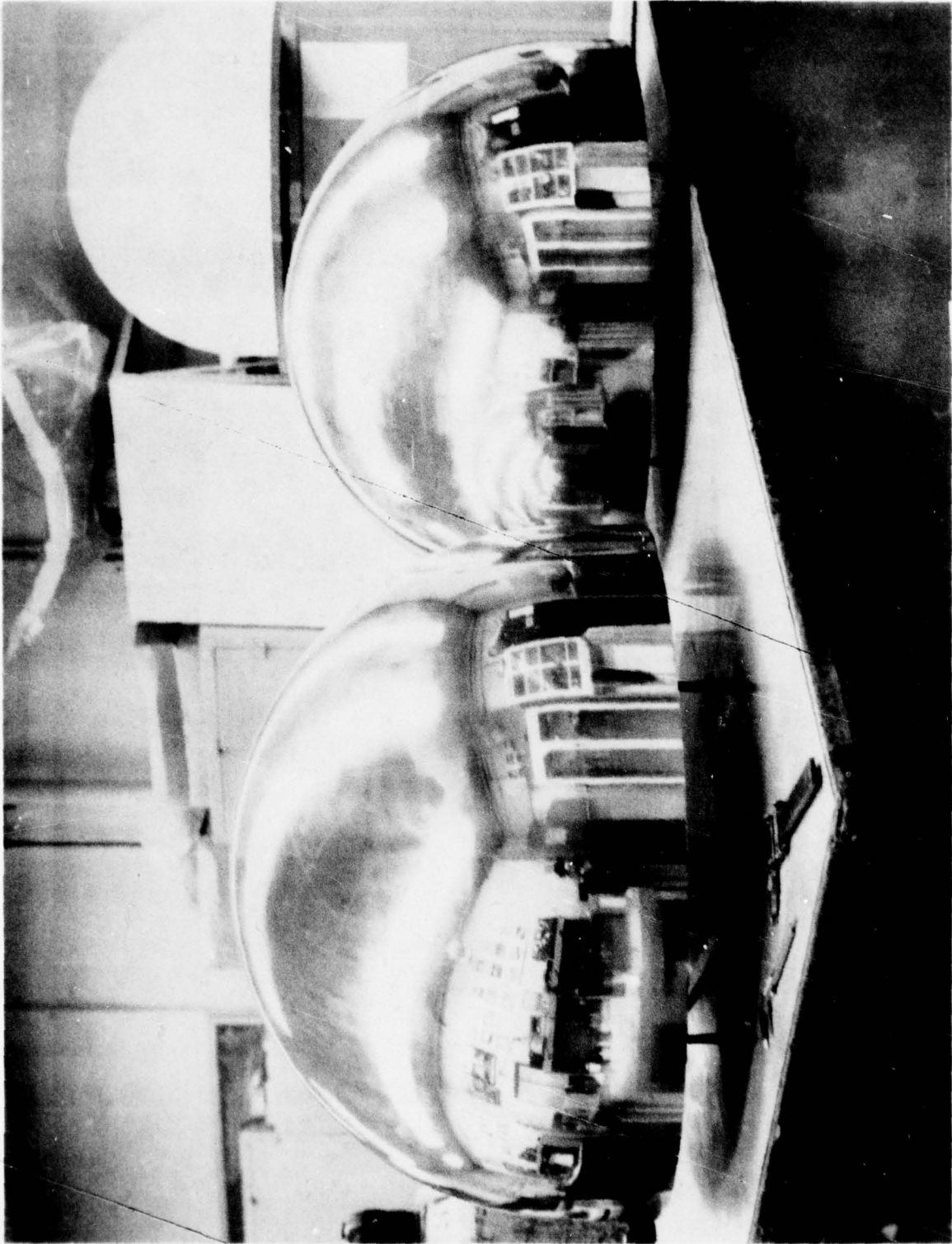

Figure 3-11. Naval Aluminum Hemispheres Polished to a 5 Micro-Inch Finish

A207443

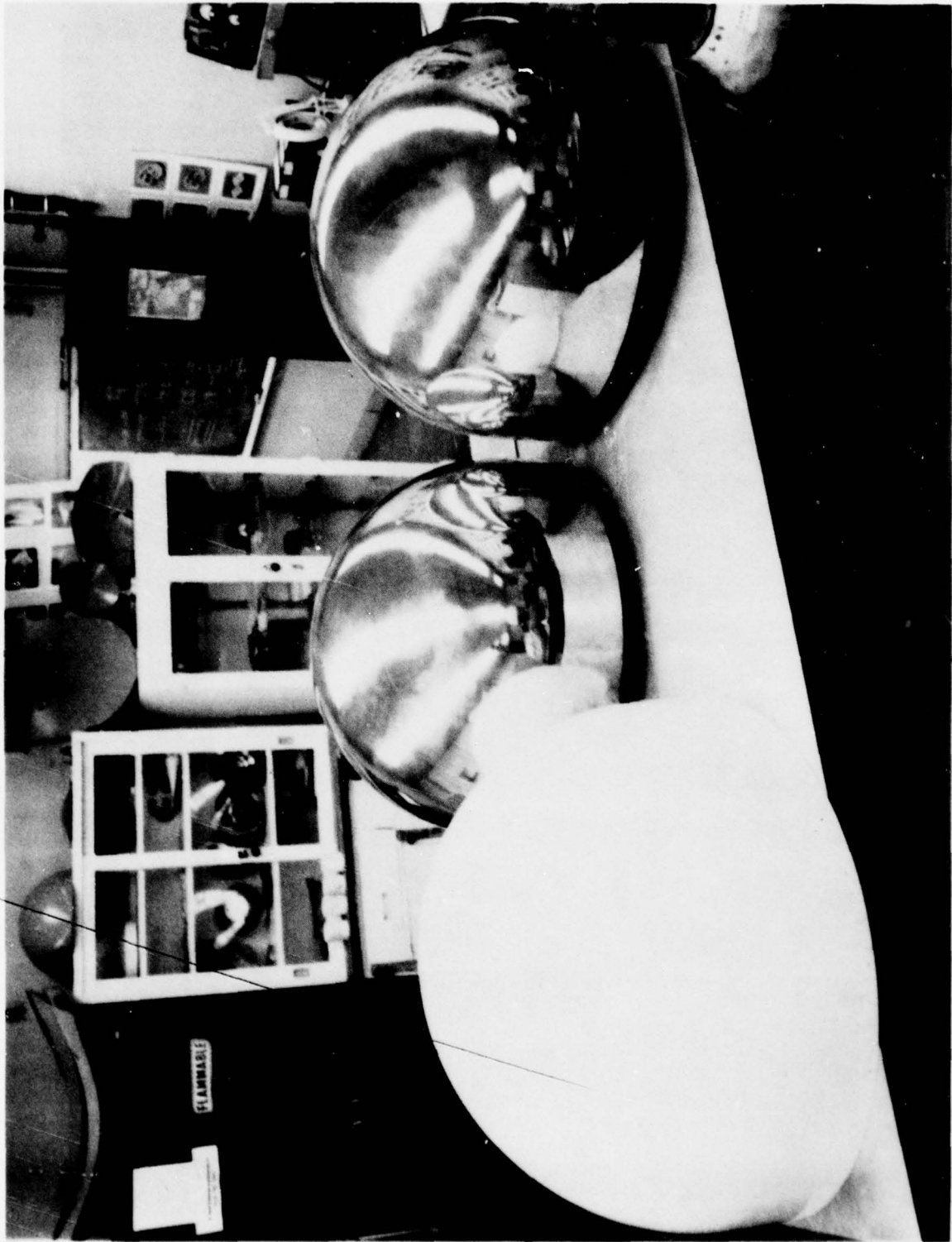

Figure 3-12. Foam-Filled/Fiberglass Radome With Outer and Inner Naval Aluminum Hemisphere

A207444



4207445

Figure 3-13. Gel Coating Aluminum Hemispheres



A207446

Figure 3-14. Application of Chopped Fiberglass to Aluminum Hemisphere



A207447

Figure 3-15. Removal of Air and Excess Resin From
Chopped Fiberglass by Rollers



A207448

Figure 3-16. Application of 1-Ounce Mat to Base of Chopped
Fiberglass Aluminum Hemisphere

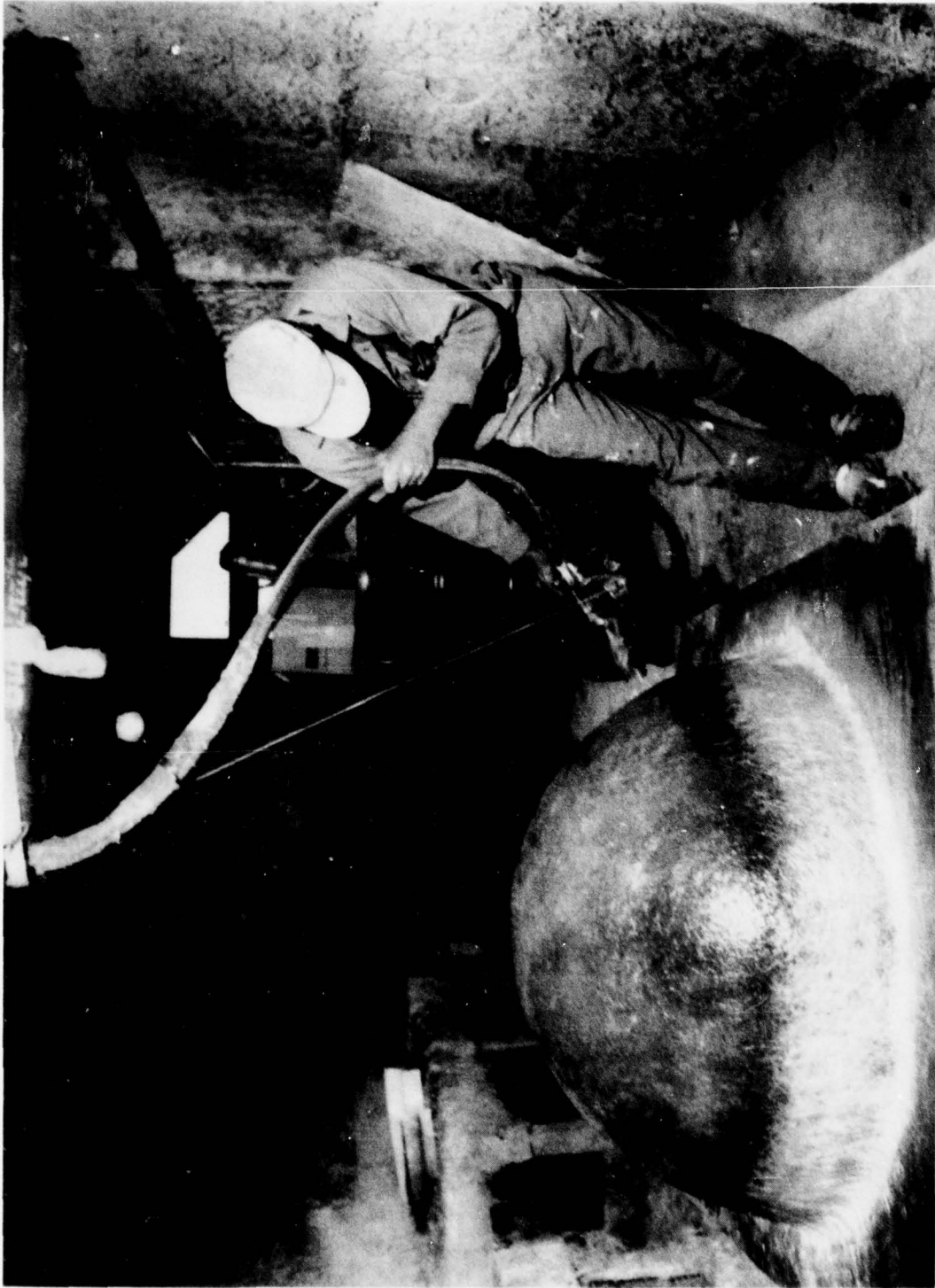

A207449

Figure 3-17. Fiberglass Mold "Classed In" to Table Top



A207450

Figure 3-18. Supporting Structure for Fiberglass Mold

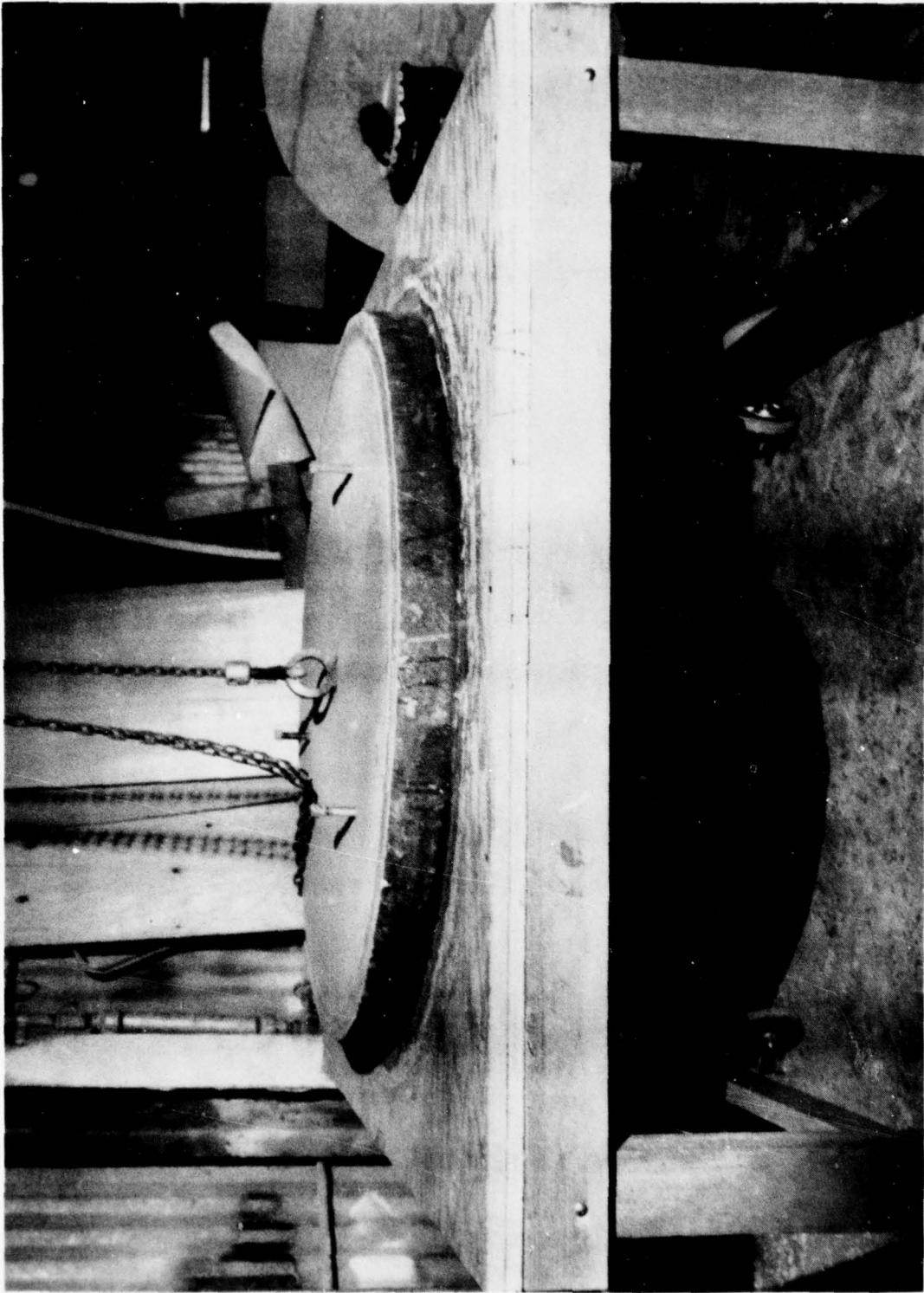

A207451

Figure 3-19. Outer Mold Assembly Bonded to Table Structure

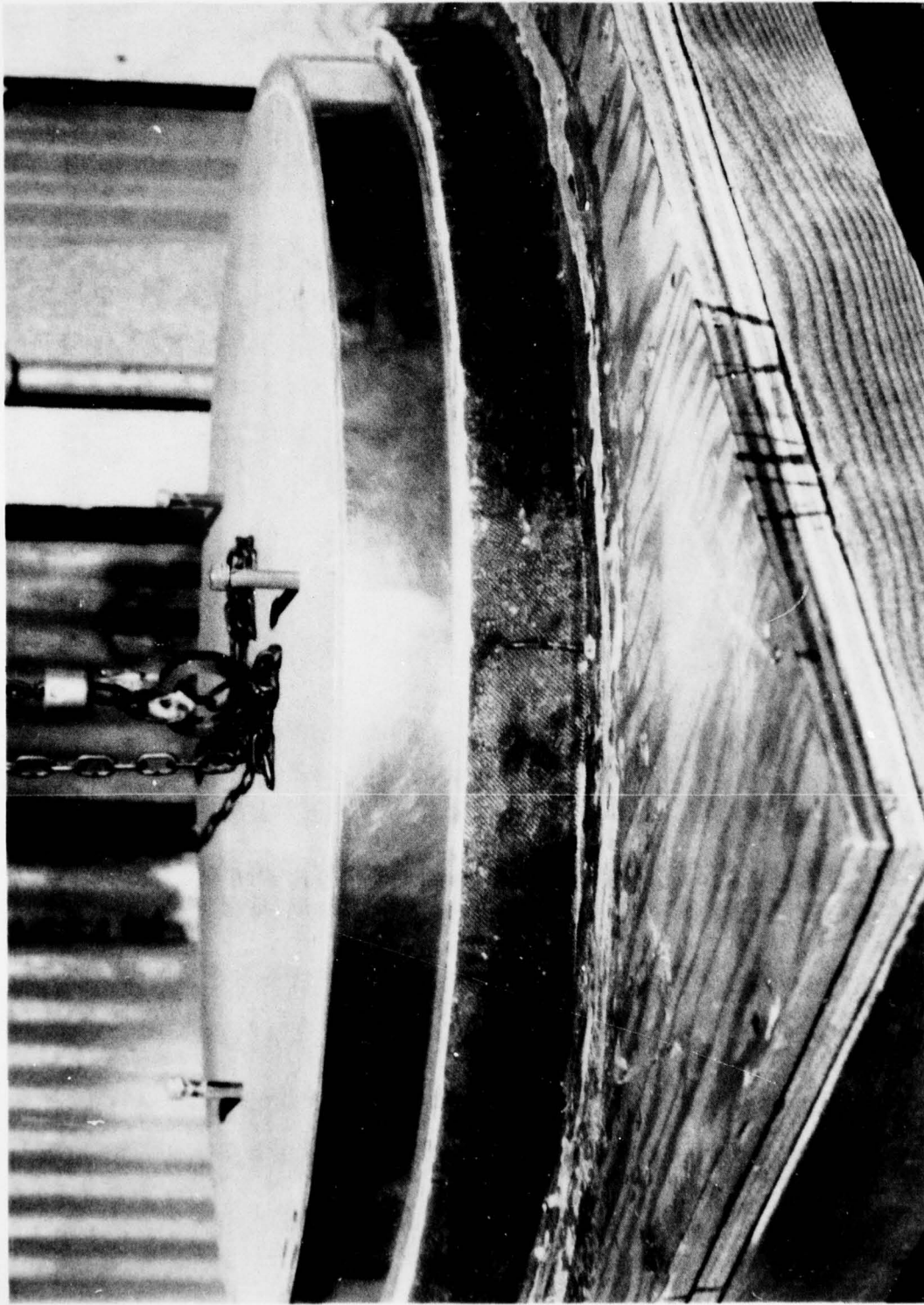

A207452

Figure 3-20. Removal of Outer Aluminum Hemisphere
From Outer Mold Assembly

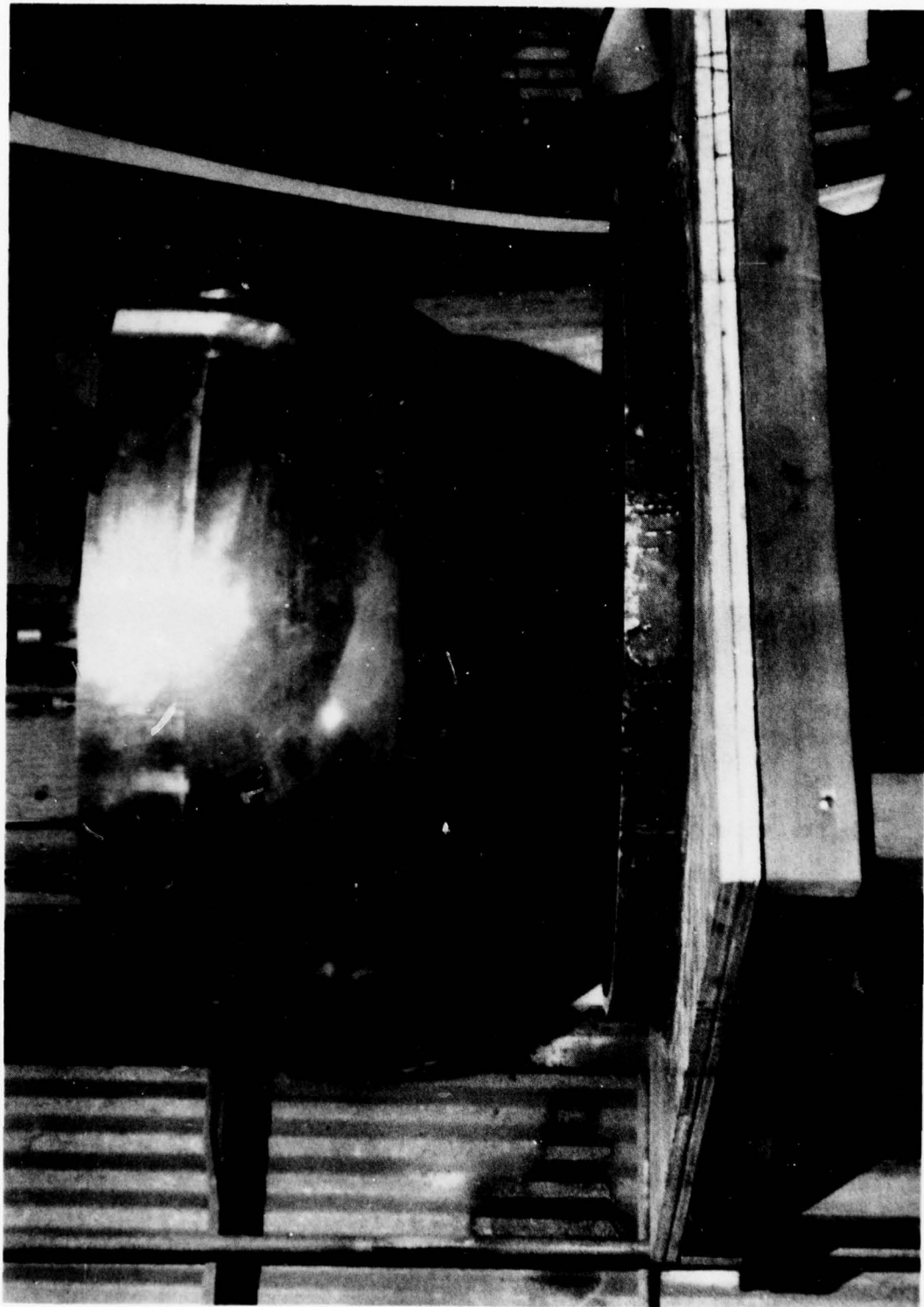
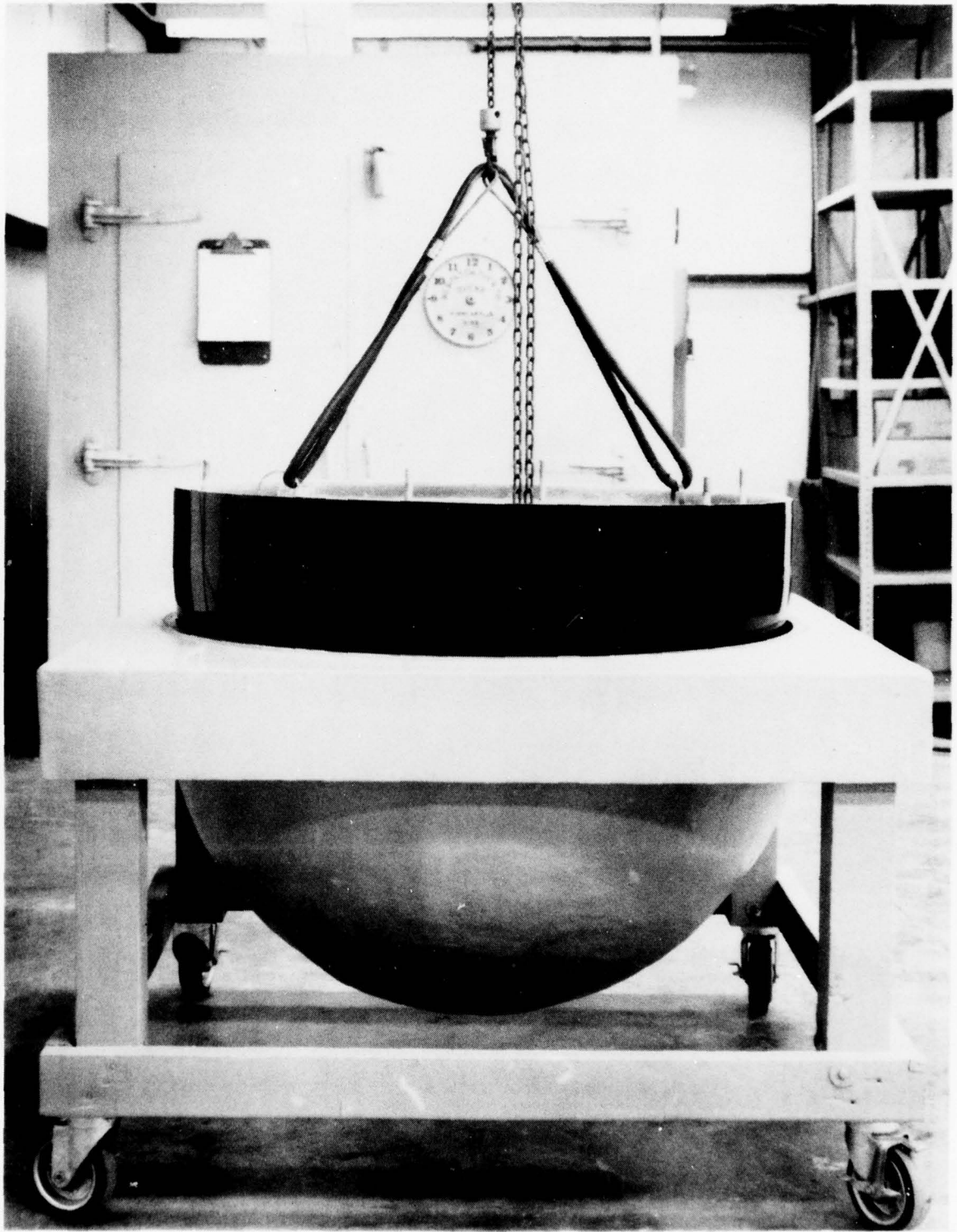

Figure 3-21. Removal of Outer Aluminum Hemisphere
From Outer Mold Assembly

A207453



A207454

Figure 3-22. Removal of Inner Plug From Inner Mold Assembly

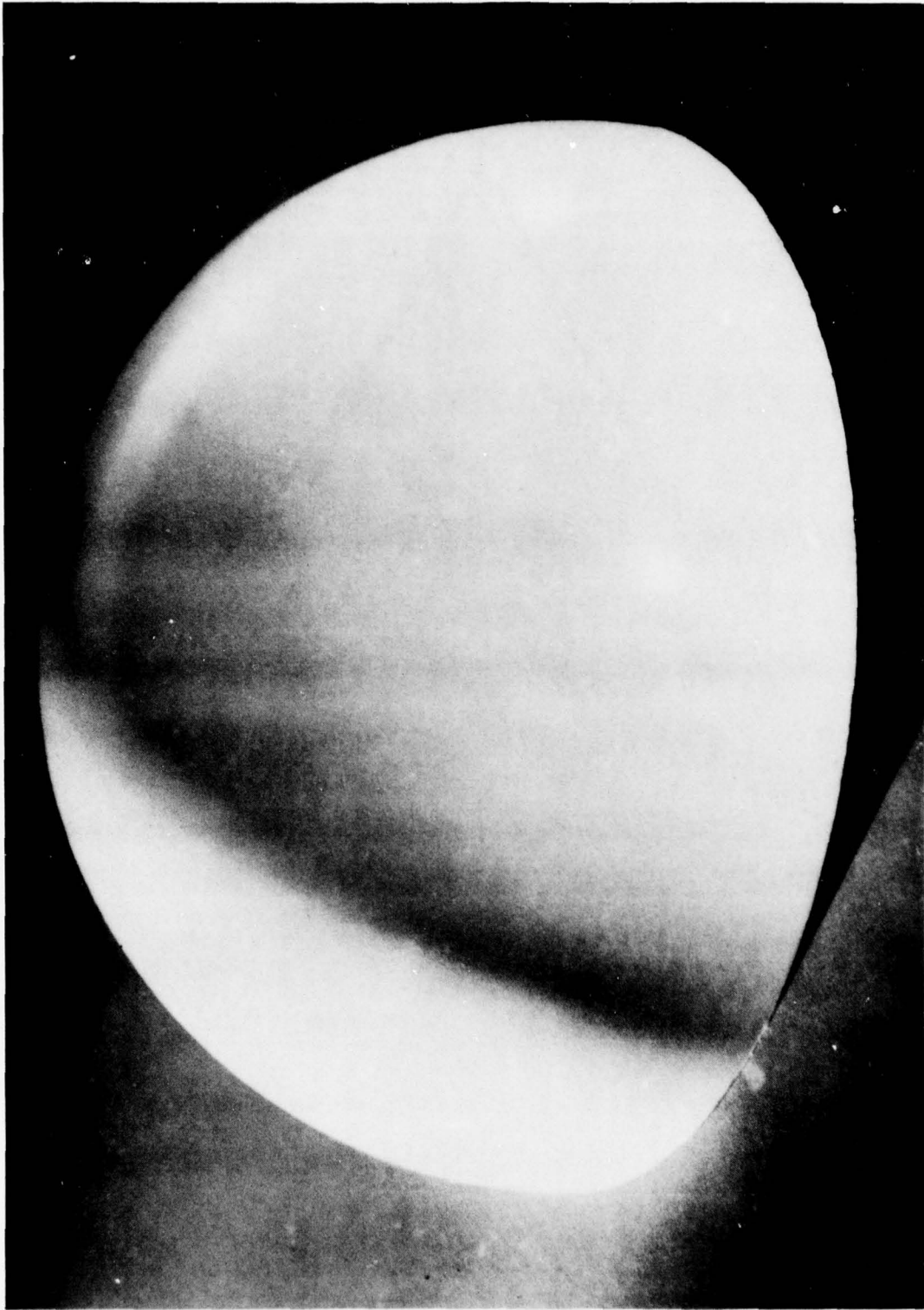

A207455

Figure 3-23. Nineteen-Inch Diameter Naval Radome Window

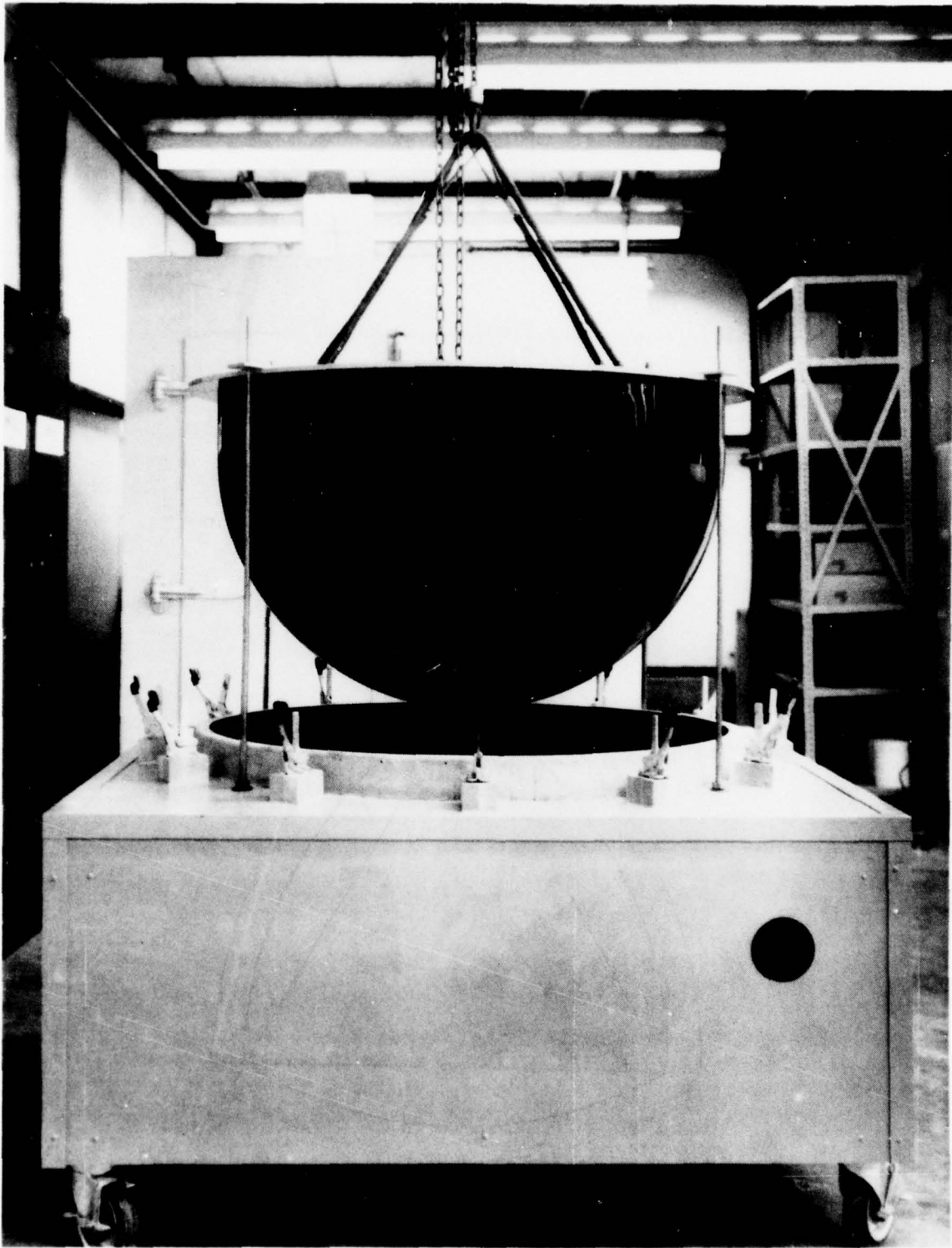

A207456

Figure 3-24. Outer and Inner Mold Assembly
Naval Radome Tooling

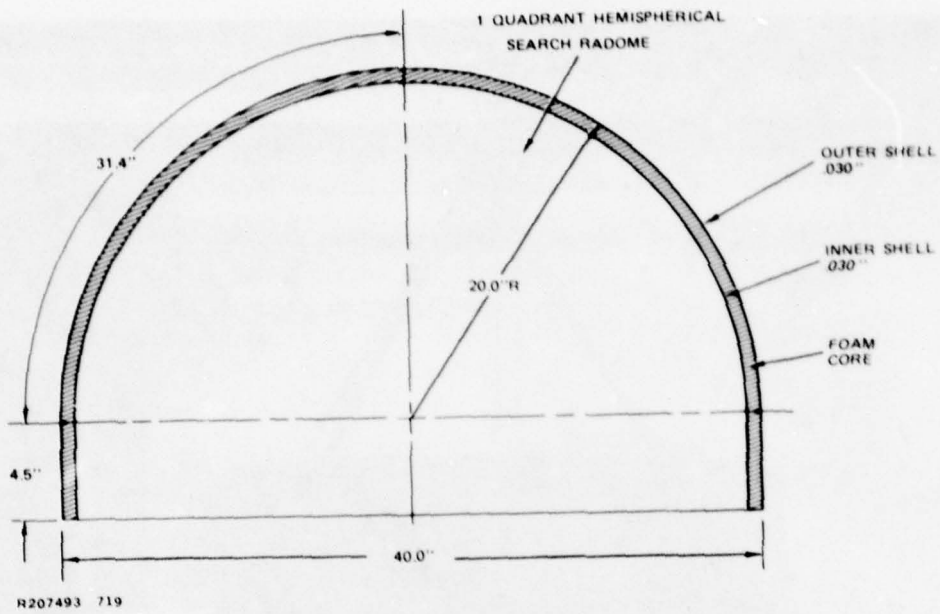

Figure 3-25. Quadrant Hemispherical Search Radome

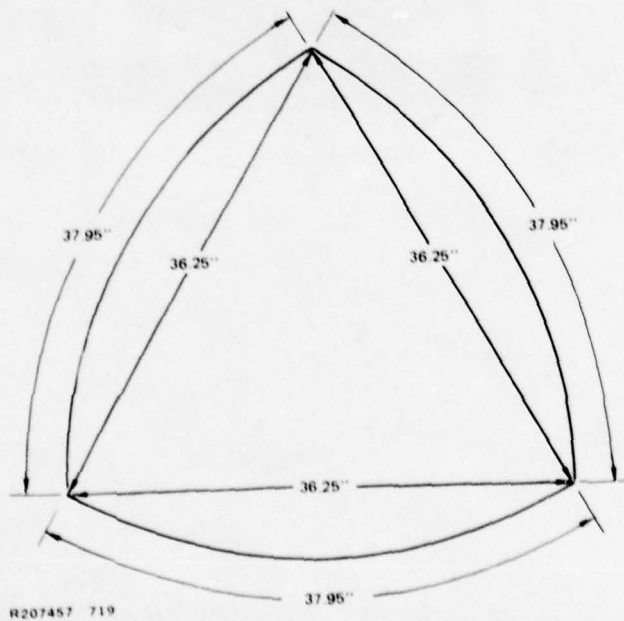
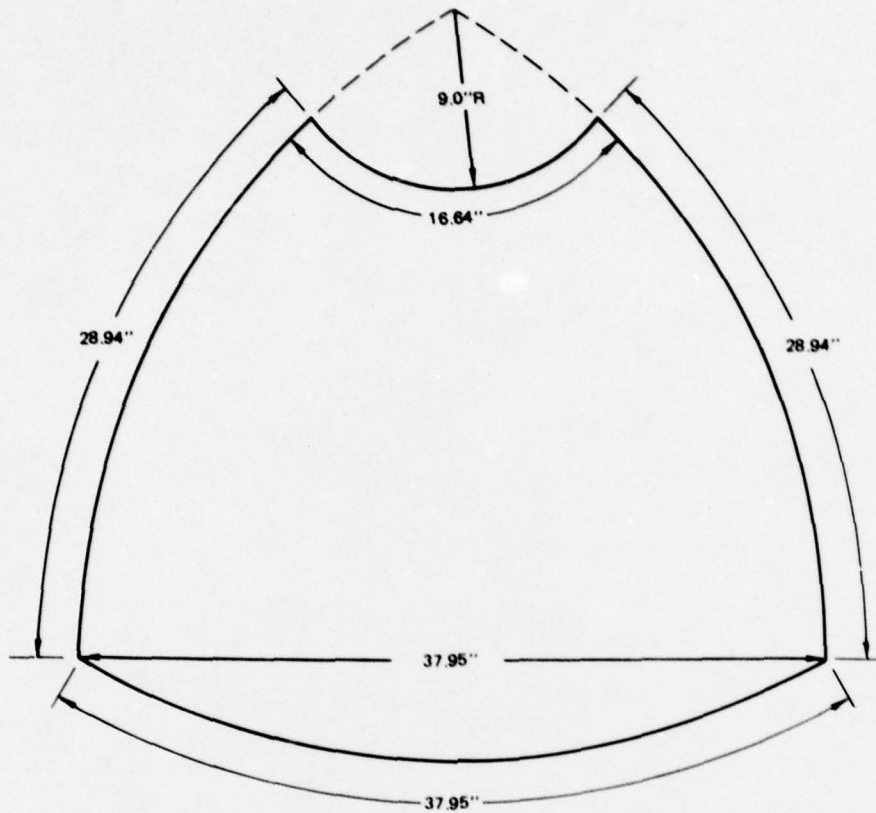
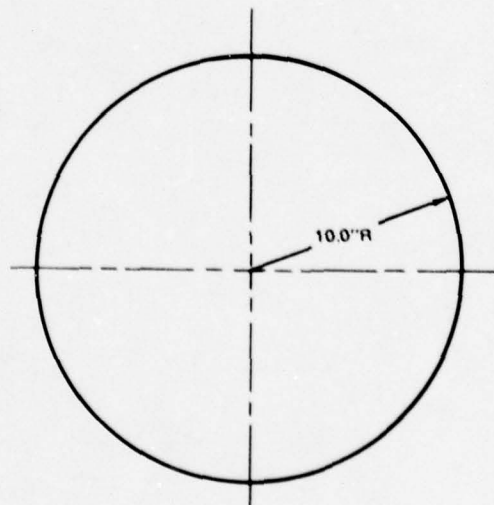

Figure 3-26. Quadrant Template



R207492 719

Figure 3-27. Quadrant Template 0.062" Aluminum



R207458 719

Figure 3-28. Circular Template 0.062" Aluminum

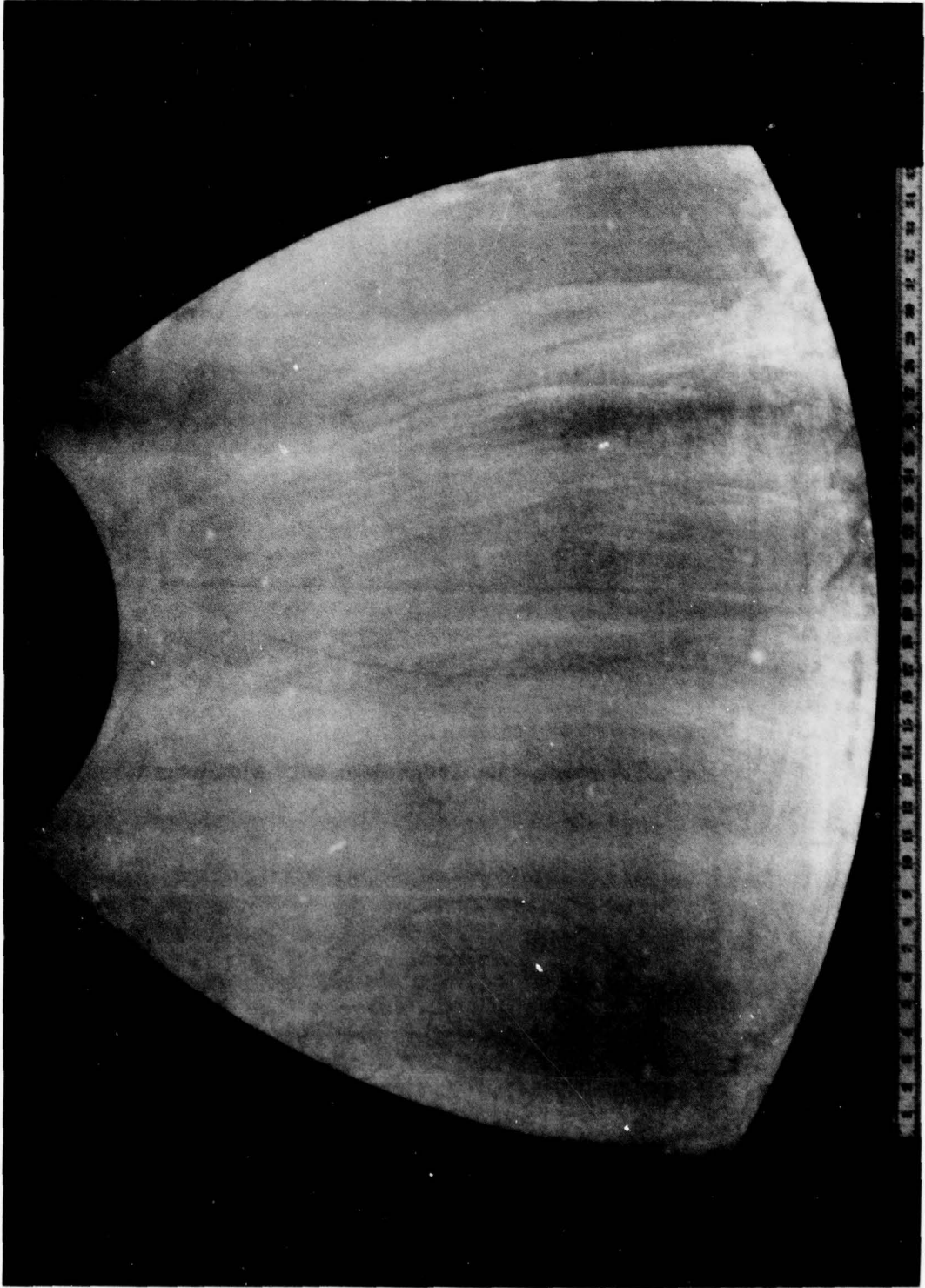

A207459

Figure 3-29. Template for Cutting Glass Cloth for
Hemispherical Search Radome

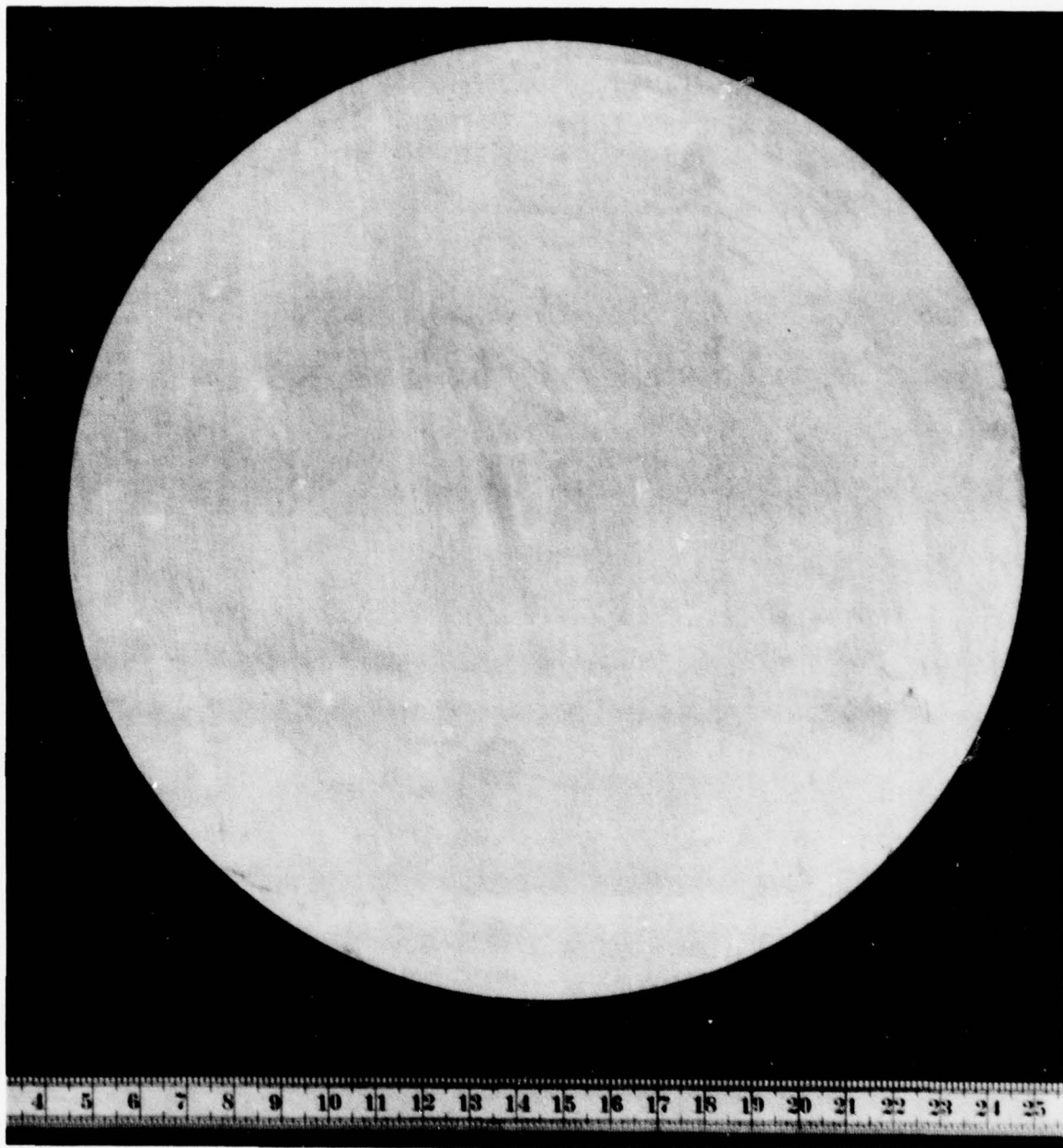

A207460

Figure 3-30. Template for Cutting Glass Cloth for Hemispherical Search Radome

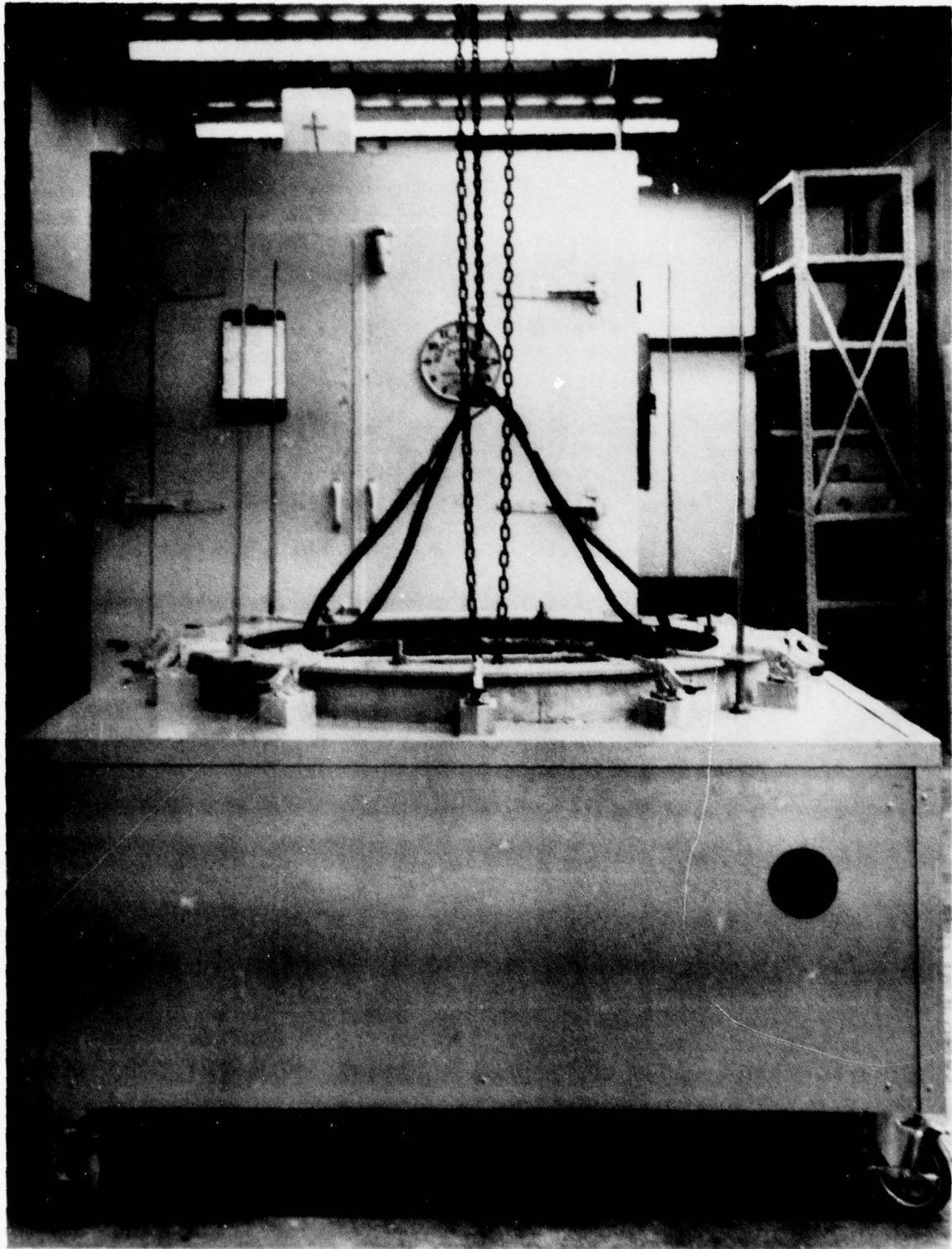

A207461

Figure 3-31. Naval Radome Mold Assembly After Oven Temperature Cure

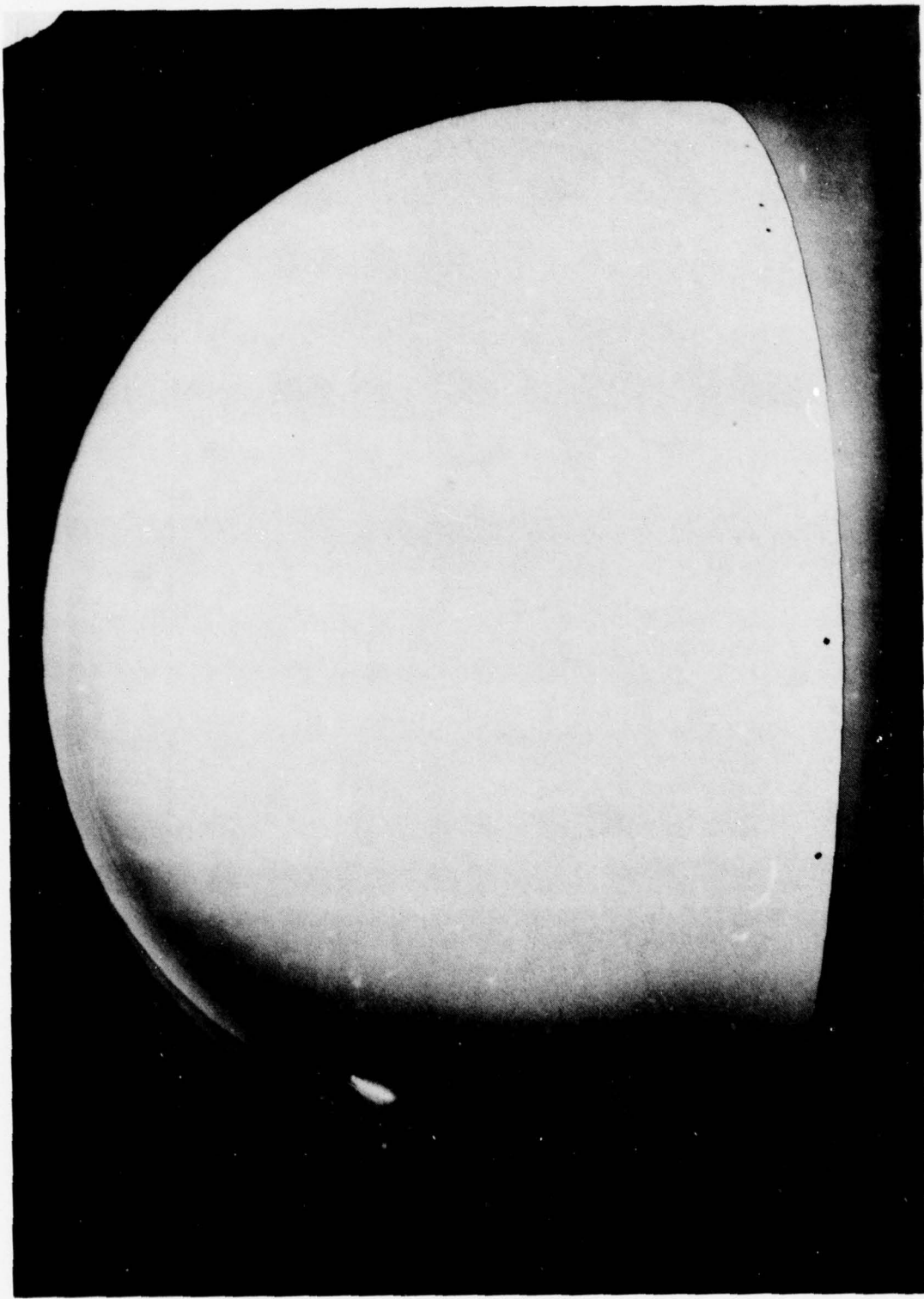

A207462

Figure 3-32. Completed Foam-Filled Seach Radome

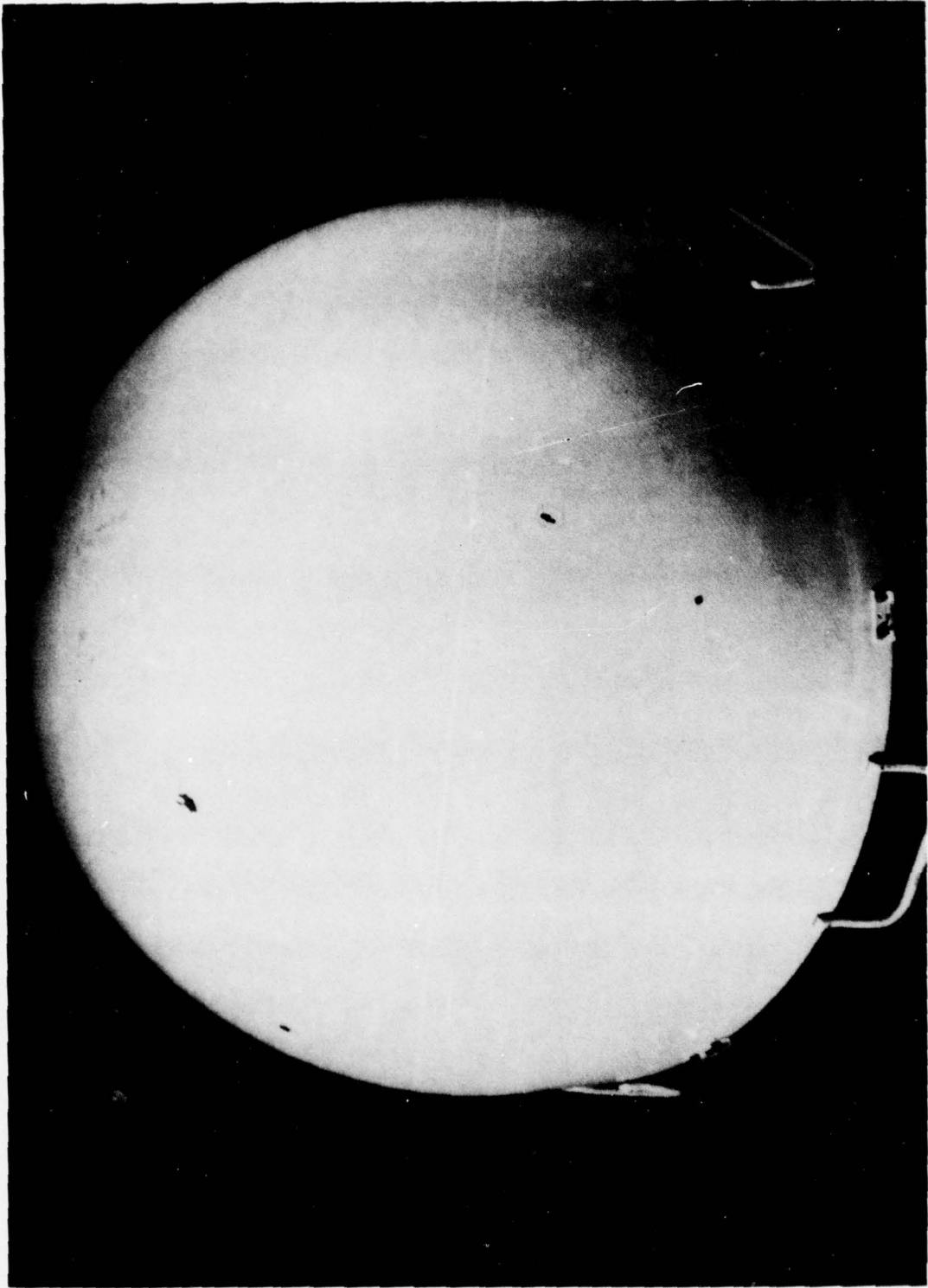

A207483

Figure 3-33. Vendor Honeycomb Radome

CDRL A003
Code Ident 9243
M-24-6-678

4.0 RESULTS ANALYSIS - SEARCH RADOME

The conclusion to this program has yielded excellent results both from a cost and design reliability standpoint, and are enumerated below.

1. R.F. transmission loss of radome is extremely low (0.1 db ave over Ku band range).
2. Excellent surface finish ($< 10 \mu$ inches) leading to the prevention of ice formation in colder regions.
3. Excellent thermal insulation to both heat or cold. (K factor of foam core = $1.8 \text{ BTU/HR/FT}^2/\text{in}/^{\circ}\text{F.}$)
4. Excellent dimensional integrity combined with good structural qualities at minimum weight. (Compressive loading force greater than 1200 lbs/ft^2 . Weight of radome = 12 lbs.)

Compared with a 40" diameter vendor honeycomb radome, RF transmission loss, surface finish, thermal insulation, hard point construction, and weight of the foam/fiberglass naval radome gave superior results.

CDRL A003
Code Ident 9243
M-24-6-678

APPENDIX A

TEST PLAN

MANUFACTURING TECHNOLOGY PROGRAM

FOR

FOAM FILLED FIBERGLASS RADOMES

CONTRACT N66011-77C-0139

CDRL A002
Code Ident 9243
M-24-6-678

Addendum to the Test Plan

Contained within this final report is the original Test Plan submitted to NOSC under Contract N66011-77-C-0139. The time schedule under authority of NOSC was extended to 15 August 1978 due to tooling delays caused by inclement weather where fiberglass operations had to be curtailed.

As explained in the Abstract Section of this final report all test results will appear as appendices at the end of the report with the appropriate group conducting the tests. The Development Process Specification and the Phalanx CIWS Design Instruction will also be submitted as appendices.

Accompanying photographs of testing procedures where applicable will also appear in the appendices containing the test results.

Introduction

This test plan is being submitted in compliance with the requirements of Contract N66001-77-C-0139, "Manufacturing Technology Program For Foam Filled Fiberglass Radomes." The test plan defines the scope of the tests required to insure that the hardware produced by the demonstrated manufacturing process meets all applicable technical, operational, and performance criteria. It presents details as to which tests are to be performed, what procedures will be used to conduct the tests, what constitutes the criteria for test results acceptance, who has the responsibility for conducting the tests, and the schedule for accomplishing the tests.

Objective

To fabricate a 40 in. diameter foam filled fiberglass radome, to the dimensions specified by the CIWS engineering drawing and to the fabrication process specifications established in this program, for the purpose of performing acceptance qualification tests. To formulate and document a test plan and procedures to determine the structural, electrical, and environmental properties of the radome and to verify that they meet all specifications consistent with the CIWS system requirements. All test data is to be documented and submitted as part of the final report along with a complete description of the corresponding manufacturing process.

PREPARED BY: W L MacTurk
W. L. MacTurk
Program Director
General Dynamics, Pomona Division

APPROVED BY: M. C. Abrams
M. C. Abrams
Chief Advanced Manufacturing Technology
General Dynamics, Pomona Division

ACCEPTED BY: John Markall
John Markall
Program Monitor
Naval Ocean Systems Center

1. Testing Requirements for 40" Diameter Hemispherical Radome of Foam/Fiberglass Construction

- a. Structural Integrity - Compressive Buckling Force.
- b. R. F. Transmission Loss - Insertion Loss.
- c. Surface Finish.
- d. Thermal Transmission - Solar Radiation.
- e. Ice Retention on Radome.
- f. Acoustic Isolation - Insertion Loss.
- g. Static Properties of Foam Core/Facings.
- h. Dimensional Constraints.
- i. Environmental Testing at Temperature Extremes.
- j. Fungus Resistance of Foam Substrate.
- k. Dielectric Constant and Dissipation Factors of Foam/Facings.
- l. Weight of Radome.
- m. Torsion Requirements on Hard Points of Radome.

2. Test Procedures on 40" Diameter Hemispherical Radome Window of Foam/Fiberglass Construction

(a) Structural Integrity - Compressive Buckling Force

A 40" diameter radome window to the dimensions required will be mounted on a vacuum table and a partial vacuum impressed on the interior of the dome. Pressure to the interior of the dome will be reduced from 1 atmosphere (14.7 lbs/in²) to 6.7 lbs/in² which will impress a force of 8 psi to the exterior of the radome.

Since the radome should be able to withstand a loading force of 500 lbs/ft² (3.47 psi) a force of 2.3 times this figure should be adequate to determine the structural integrity of the radome window.

Deflection transducers mounted to the exterior of the radome will be used to measure deflection versus force and will be recorded on an XY plotter. Strain gages will also be mounted to the interior and exterior of the radome.

(b) R.F. Transmission Loss - Insertion Loss

R.F. transmission through the radome and the loss incurred will be measured on the antenna range at the GD/Pomona facility.

A search antenna will be illuminated and boresighted for proper azimuth and elevation and the gain recorded. The radome will then be placed over the search antenna and the lower gain then recorded. Maximum RF transmission loss shall be no greater than 0.75 db between 13 and 15 GHz.

(c) Surface Finish of Radome Window

Surface finish of the radome will be measured on a direct reading calibrated profilometer. Surface finish shall be no greater than 20 μ inches RMS. Measurements conducted in the past on a 40" diameter radome of identical facings and foam construction have shown readings as low as 5 to 6 μ inches RMS. (See GD/PD MTR 77/055.)

(d) Thermal Transmission - Solar Radiation

Experiments conducted in the past have shown the large thermal insulation afforded by this type of radome construction when exposed to direct sunlight over a duty cycle of 38 hours. Due to the low thermal conductivity of the 2 lb/ft³ polyurethane foam used (.18 BTU/HR/FT²/IN^{OF}) a large temperature differential exists between the ambient temperature and the interior of the radome. This test will not be re-run but data and graphs extracted from GD/PD MTR 77/055 will be furnished with the test report.

(e) Ice Retention to Exterior Surface of Radome

Previous tests the proceeding year have shown that ice retention and buildup do not impose a problem on this type of radome when the gel coated surface has a finish below 10 inches. Ice build up at temperatures as low as -40^oF is easily removed with gentle tapping with no de-icing capabilities of this type of radome.

(f) Acoustic Loss Versus Frequency

A sample foam panel with facings and foam of identical thickness and construction to the 40" diameter hemispherical radome will be tested in an acoustic chamber. Acoustic pressures of 145 db will be impressed on one side of the flat polyester glass/foam panel and the acoustic loss measured on the opposing side. This will be examined at frequencies between 20 Hz to 2 KHz and the data recorded. Acoustic insertion loss shall be no less than 25 db over the measured frequency band.

(g) Static Properties of Foam Core/Facings

These tests have already been conducted by Dr. D. Anderson of the Structural Analysis Group of GD/Pomona and will be submitted with the test procedures and report. These tests comprise,

1. Core Tension
2. Core Compression
3. Core Shear
4. Facing Tension
5. Facing Compression
6. Sandwich Flexure and Fatigue Properties

All tests conducted were on 2 lb density free rise foam and facing thicknesses of $\pm .035$ ", and conformed to the facing thickness and foam used on the construction of the 40" diameter hemispherical radome to be tested.

(h) Dimensional Constraints of Radome

Trueness, height, diameter, and thickness of the radome will be measured with standard tool shop instruments such as micrometers, height verniers, and calipers. No dimension measured shall exceed a tolerance of $\pm .030$ ".

(i) Environmental Testing at Temperature Extremes

Radome samples will be temperature cycled between -40°F to 160°F in a calibrated thermal chamber for 10 cycles at temperature durations called out on Mil-Std. 202D. Samples will be examined at the conclusion of the environmental cycling for fissuring or cracking of the radome facings and/or delamination of the facing/foam adhesion.

No failure permitted in either of the above.

(j) Fungus Resistance of Foam Substrate

Since the foam is encapsulated between the polyester glass facings of the radome and the base of the radome sealed with a non nutrient polyurthane elastomer (PRC 1660) no fungus resistance tests will be conducted. A lab report from Products Research and Chemical Corp. will be submitted which shows the sealing elastomer (PRC 1660) has been tested to Mil-Std 810B - Fungus Resistance and is non nutrient.

(k) Dielectric Constant and Dissipation Factors of Foam/Facings

The dielectric constant (ϵ) of the foam substrate and polyester glass facings will be tested by Advanced Manufacturing Technology to verify the vendors specification sheets for this value. This will also be done for the loss tangent of the foam to also verify the vendor's specification for this value. In addition to the individual constituent values the composite structure value will be determined as a verification of the end product.

Method of testing will be submitted with the test results.

(l) Weight of Radome

Weight of radome shall be no greater than 15.8 lbs.
This will be measured on a calibrated Ohaus Solution
Balance - 20 Kg capacity.

(m) Torsion Requirements on Hard Points of Radome

A #10 screw and nut will be torqued at each hard point
to a force of 27 in/lbs with a calibrated torque wrench.
This will be done with latch attachments in place. No
cracking of facing or facing delamination from hard points
allowed.

3. Criteria for Successful Test Determination

Where applicable all tests conducted will meet the requirements
specified in the Design Instruction Environment (433-BE-086B)
Phalanx (CIWS) Ship Gun System. This embraces the following tests.

a. Structural Integrity - Compressive Buckling Force
Radome must withstand a wave loading force of 500 lbs/ft².

f. Acoustic Isolation - Insertion Loss.

Insertion loss must be greater than 25 db across the
measured frequency band.

Item (b) R.F. Transmission Loss is taken from drawing 3161017 and
tested to M-223-9. 8-89"A". Maximum insertion loss
across the band is 0.75 db.

Since this new concept in radome design replaces the
original Phalanx radome which consisted of a honeycomb
design with epoxy glass facings other tests have been
added which are not incorporated in the original Design
Instruction. These additional tests were imposed to
ensure design reliability. Such items are listed under
"Testing Requirements" heading and include,

- c. Surface Finish of Radome
- e. Ice Retention
- g. Static Properties of Foam Core/Facings
- i. Environmental Testing at Temperature Extremes

Item (c) was not defined in the original Phalanx radome.

Item (e) Ice Retention, in consequence of Item (c) removes the problem of de-icing requirements specified in the Design Instruction for the Phalanx CIWS.

Item (c) Surface Finish will be measured on the foam/fiberglass radome and will meet the surface finish requirements of $< 10 \mu$ inches RMS.

Item (e) Ice Retention Test will not be re-run as mentioned in the "Test Procedures" paragraph but data taken previously on this test will be submitted. Ice build up should have a bonding force on the radome of no greater than 5 psi.

Item (g) Static Properties of Foam Core/Facings will be conducted by the Structural Dynamics group at this facility and will show that the foam core and gel coated polyester glass facings of type of radome structure will adequately meet the Design Instruction Environments of the Phalanx CIWS (D1433-BE-086(-87)).

Item (i) Environmental Testing at Temperature Extremes will determine the ability of the foam core/facings of this radome to withstand the temperature extremes of -40°F to 160°F without fissuring of the facings or delamination of the facings from the foam substrate.

Item (k) will be required to meet the following dielectric constant and dissipation factor values specified in vendor physical and electrical data sheets.

* Polyester/Facings	ϵ	Tan σ
Koppers 1061-5 Polyester Resin	$4.1 \pm .1$.025 max
Foam (2 lb/ft ³ Free Rise) (9 lb/ft ³ restrained density)	$1.18 \pm .1$	0.6×10^{-3} $\pm .1 \times 10^{-3}$

Tests on dielectric constant and loss tangent will also be conducted on the gel coated 4 oz glass cloth facings used on the radome and also on the complete sandwich of fiberglass facings and foam core. These values at present are unknown.

* This refers to the dielectric constant of the polyester resin when used as a laminate. Laminate utilizes a 181 glass cloth specified under Mil-C-9084C.

4. Test Responsibility

- A. Testing of items (a) (f) and (g) will be conducted by Structural Dynamics, Engineering Group 348 under the direction of Mr. D. A. Underhill, and all data and results submitted with the final test report.
- B. Testing of item (b) R.F. Transmission Loss will be conducted by Engineering Group 223 (Antennas & Microwave) under the direction of Mr. Peter Johnson.
- C. Testing of items (c) and (h) will be conducted by the Quality Assurance Group Dept. 27 under the supervision of Mr. H. J. Harrel.
- D. Testing of item (i) Environmental Integrity at Temperature Extremes will be done by Dept 24-6 Advanced Manufacturing Technology under the direction of Dr. M. C. Abrams.
- E. Item (k) will be tested by Dept 24-6 Advanced Manufacturing Technology under the direction of Dr. M. C. Abrams.
- F. Items (l) and (m) will be tested by Dept 24-6 Advanced Manufacturing Technology under the direction of Dr. M. C. Abrams.

5. Time Schedule May/June 1978

TASK	MAY	JUNE
1. Testing of Structural Integrity of Radome	_____	
2. Testing of R.F. Transmission Loss		_____
3. Testing of Acoustic Insertion Loss	_____	
4. Dimensional Testing of Radome and Surface Finish		_____
5. Environmental Testing at Temperature Extremes	_____	
6. Dielectric Constant & Dissipation Factor Tests on Foam/Facings	_____	
7. Final Report		_____

CDRL A003
Code Ident 9243
M-24-6-678

APPENDIX B

STRUCTURAL INTEGRITY - COMPRESSIVE BUCKLING FORCE

GENERAL DYNAMICS
Pomona Division

TECHNICAL MEMORANDUM

TM
6-348-62.57-2
MODEL
CONTRACT

DATE: 25 May 1978
TO: Distribution
FROM: Structural Dynamics - Section 348

SUBJECT:
RADOME STRUCTURAL TEST REPORT - NAVY RADOME DEVELOPMENT PROGRAM

REFERENCE:

DISTRIBUTION:

LIBRARY (5)
Hiroshige, K. 4-45
Abrams, M. C. 4-26
MacTurk, W. L. 4-26
Kersbergen, G.V. 4-53
Sloan, W. O. 4-53

PREPARED BY:

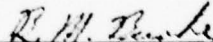

B. M. Burke

PREPARED BY:

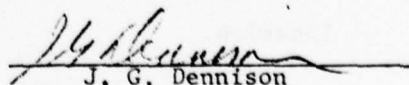
REVIEWED BY:

J. G. Dennison

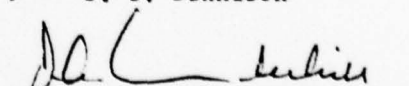
APPROVED BY:

D. A. Underhill

Section Head - Structural Dynamics

(D) FORM 6-660 R1

SUMMARY

In support of a Navy Radome Development Program a test was performed on a radome provided by Department 24. The radome was a 40 inch diameter hemisphere with a 4.5 inch cylindrical section at the base. The radome was of sandwich construction with polyester resin-glass cloth facings and a rigid urethane foam core. Total thickness was 0.264 inches nominal with 0.190 inch core. The urethane foam used has a nominal free rise density of 2 lbs/ft³. The test imposed a uniform radial load on the radome by pulling a partial vacuum on the interior. The required limit load was 500 lbs/ft² (3.47 psi). Maximum test load was 1166 lbs/ft² (8.10 psi) or 233% of the limit load. Post test examination showed no damage was sustained by the test specimen. The minimum test factor of safety is then 2.33.

TEST PROCEDURE

The test specimen was placed on an aluminum base plate. Attachment to the plate was made by pressing the edge of the radome in a bead of duct seal. The lower 3/4 inches of the radome was restrained radially by a plywood ring. The radome was loaded by pulling a partial vacuum on the interior of the radome. A mercury manometer was used to measure the vacuum achieved. Eight type BAE-13-250BB-120 strain gages were used to measure strain in the radome. The vacuum was increased in increments of 2.0 inch of mercury. The strain was read at each increment. Figure 1 shows the test set-up and instrumentation.

TEST RESULTS

Table 1 gives the strain vs load data obtained during the test. Post test examination of the test specimen revealed no sign of damage to the radome. Table 2 lists the strain gages, their orientation and location.

TABLE 1
STRAIN (MICROINCHES) VS LOAD (IN. Hq & LB/IN²)

LOAD		GAGE							
Hq. in.	lb/in ²	1	2	3	4	5	6	7	8
0	0	0	0	0	0	0	0	0	0
2	.98	-50	-90	-130	-80	0	-70	-240	-30
4	1.96	-160	-190	-270	-170	-40	-150	-410	-40
6	2.95	-260	-290	-430	-240	-80	-230	-620	-80
8	3.93	-350	-390	-600	-290	-140	-310	-770	-120
10	4.91	-430	-480	-750	-350	-190	-390	-900	-170
12	5.89	-510	-570	-900	-400	-240	-460	-1080	-240
14	6.87	-590	-660	-1070	-460	-290	-540	-1215	-285
16.5	8.10	-670	-760	-1250	-520	-360	-630	-1400	-350

TABLE 2
STRAIN GAGE ORIENTATION AND LOCATION

GAGE	ORIENTATION	LOCATION
1	Normal to Meridian	Inside, 5" from apex
2	Along Meridian	" " " "
3	Normal to Meridian	Inside, 6" from bottom
4	Along Meridian	" " " "
5	Normal to Meridian	Outside, 5" from apex
6	Along Meridian	" " " "
7	Normal to Meridian	Outside, 6" from bottom
8	Along Meridian	" " " "

DISCUSSION

Tests on coupons cut from skins of a CIWS Track Radome which were fabricated in the same manner as those of the test specimen gave the following properties (Ref. TM 6-348-62.57-1, Pilotline Track Radome-Structural Test Report).

$$12000 \text{ psi} \leq F_{tu} \leq 18000 \text{ psi}$$

$$0.8 \times 10^6 \text{ psi} \leq E \leq 1.2 \times 10^6 \text{ psi}$$

From this data and measured strain at 233% of limit load the maximum measured stress in the test is

$$f = \frac{E}{1-\mu^2} (\epsilon_3 + \mu\epsilon_4)$$

$$f = \frac{1.2}{1-.12^2} [-1400 + (.12)(-350)] = -1748 \text{ psi (compression)}$$

where Poisson's ratio μ is assumed to be .12

Since no material or stability failure was observed the minimum test factor of safety is 2.33.

GENERAL DYNAMICS
Pomona Division

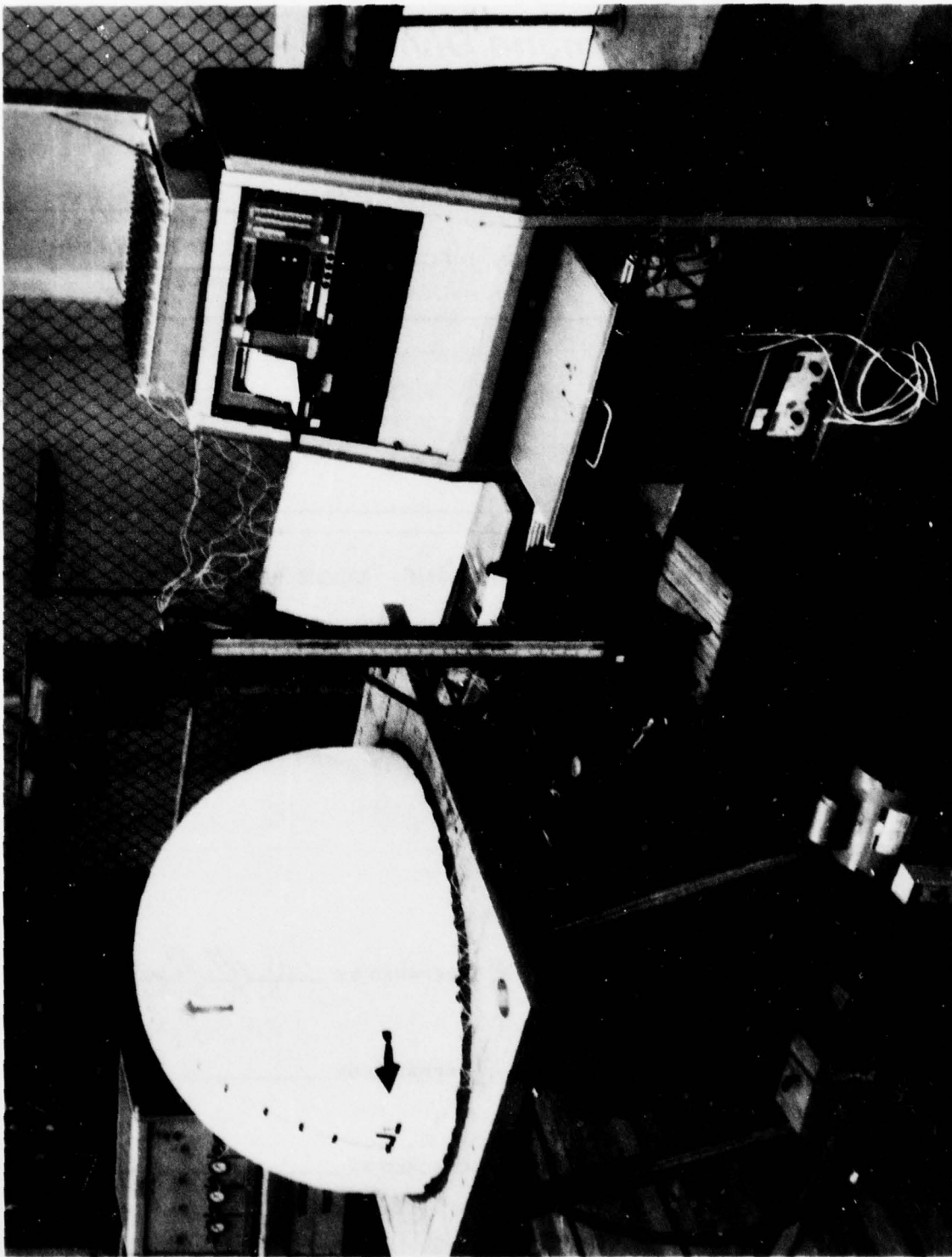

STRUCTURAL LOADING OF 40" DIA.
NAVAL HEMISPHERICAL RADOME

FIGURE 1

P.O. 5-78-81526

GENERAL DYNAMICS

Pomona Division

Pomona Division

STRUCTURAL DYNAMICS DESIGN INFORMATION

STRUCTURAL DYNAMICS DESIGN INFORMATION

SDDI
6-348-62;57-4

MODEL

DATE: 12 July 1978

TO: W. L. MacTurk - MZ 4-26

FROM: Structural Dynamics - Section 348

SUBJECT: NAVY RADOME DEVELOPMENT PROGRAM - RADOME RADIAL DEFLECTION

DISTRIBUTION:

DISTRIBUTION

PREPARED BY: B. M. Burke
B. M. Burke

PREPARED BY: _____

CHECKED BY: _____

APPROVED BY: D. A. Underhill
D. A. Underhill
Section Head - Structural Dynamics

The radial deflection of the Navy Development Radome under external pressure has been calculated from data obtained during the structural test program, see TM 6-348-62.57-2 Radome Structural Test Report. The calculated radial deflection was -0.185 inches with an external pressure of 8.10 psi (233% of limit load).

The calculation was performed using the following equation.

$$r_o = R_o h (1 + \epsilon_o) / [R_o (\epsilon_o - \epsilon_i) + h (1 + \epsilon_i)]$$

where:

- r_o = radius of curvature of outer radome surface under external pressure
- R_o = radius of curvature of unloaded outer radome surface.
- h = radome sandwich thickness
- ϵ_o = strain under load along meridian on external surface
- ϵ_i = strain under load along meridian on internal surface.

From the test reported in TM-6-348-62.57-2 the following values were obtained:

- P = 8.10 psi external pressure
- R_o = 20.0 inches
- h = 0.264 inches
- ϵ_o = -0.00063 inches/inch
- ϵ_i = -0.00076 inches/inch
- $\therefore r_o$ = 19.815 inches and $\Delta R_o = r_o - R_o = -0.185$ inches

Derivation of the governing equations is given below.

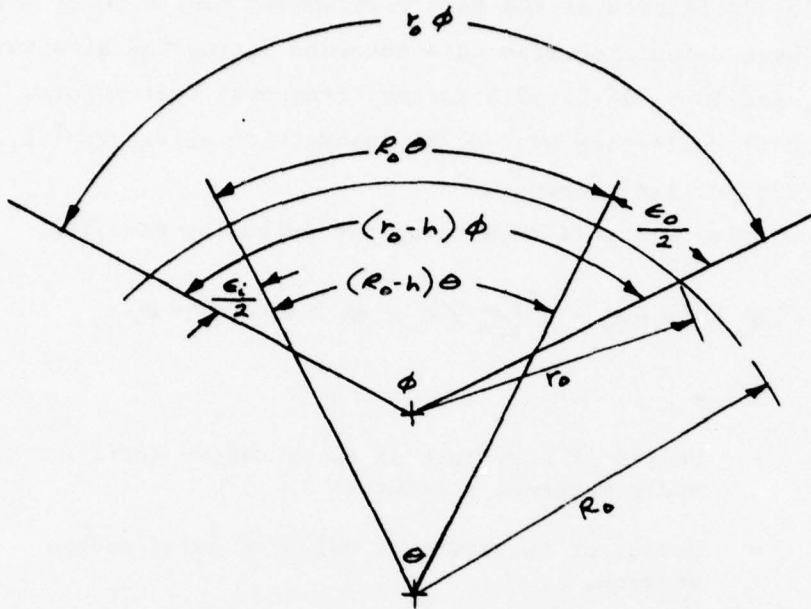

$$r_0 \phi = R_0 \theta (1 + \epsilon_0)$$

$$(r_0 - h) \phi = (R_0 - h) (1 + \epsilon_i) \theta$$

$$r_0 \phi - h \phi = (R_0 - h) (1 + \epsilon_i) \theta$$

$$h \phi = R_0 \theta (1 + \epsilon_0) - (R_0 - h) (1 + \epsilon_i) \theta$$

$$\phi = [R_0 \theta (1 + \epsilon_0) - (R_0 - h) (1 + \epsilon_i) \theta] / h$$

$$r_0 = R_0 h \theta (1 + \epsilon_0) / [R_0 \theta (1 + \epsilon_0) - (R_0 - h) (1 + \epsilon_i) \theta]$$

$$= R_0 h (1 + \epsilon_0) / [R_0 (\epsilon_0 - \epsilon_i) + h (1 + \epsilon_i)]$$

CDRL A003
Code Ident 9243
M-24-6-678

APPENDIX C

R.F. TRANSMISSION LOSS - INSERTION LOSS - SEARCH RADOME

GENERAL DYNAMICS
Pomona Division

MEMORANDUM

M	6-223-3.8-31
MODEL	

DATE: 10 July 1978

TO: W. L. MacTurk

FROM: H. P. Johnson

SUBJECT:

Radome Electrical Test Report - Navy Radome Development Program.

REFERENCE:

DISTRIBUTION:

A. Bessette
M. C. Abrams

PREPARED BY: 
H. P. Johnson

PREPARED BY: _____

REVIEWED BY: _____

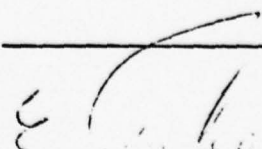
APPROVED BY: 
E. Tahan Section Head,
Microwave and Antennas

GENERAL DYNAMICS
Research Division

SUMMARY

In support of a Navy Radome Development Program an RF insertion test was performed on a radome provided by Advanced Manufacturing Technology, Dept. 24. The radome was of "A" sandwich construction with polyester resin-glass skins and a rigid urethane foam core. The radome shape was basically a 40 inch diameter similar to the Phalanx search radome now in production. The RF insertion loss using a Phalanx search antenna was less than the specification of 0.75 dB.

TEST PROCEDURE

The radome was placed on a Phalanx servo structural so that the radome and search antenna were in proper relative position. An illuminating source placed 400 feet away radiated the search antenna, initially, without the radome for a reference level then the radome was mounted in place and the test repeated. The difference in received signal level represented the insertion loss.

TEST RESULTS

The attached data sheet shows the measured and specification loss data taken over the 6% operating bandwidth.

GENERAL DYNAMICS
Pomona Division

5575

TEST PROCEDURE

M6-223-9.8-89 "A"
MODEL PHALANX OSM
CONTRACT
DRAWING NO. 3161017 & 2923532

DATE: ~~11 July 1975~~ 19 May 1976 "A"
TO: Distribution
FROM: Microwave & Antennas, Group 223

SUBJECT: Phalanx OSM Test Procedure used for Testing the Track and Search Radomes, Drawings 2923532 and 3161017.

REFERENCE:
(a) M6-223-24.13-301 (C) Phalanx ADM Transmitter/Receiver Frequency Range, 14 January 1975.
(b) M6-223-24.6-104 Test Procedure for Phalanx Prototype Track and Search Radomes, 22 June 1972.

DISTRIBUTION: Revisions: "A" - Pages 2 and 4 (Delete tests at (F_0+250) & (F_0-250) MHz)

A. W. Doriguzzi
W. C. Miller
R. E. Naegle
T. B. Nersisi
P. A. Stiles

PREPARED BY: S. D. Garcia
S. D. Garcia

REVIEWED BY: J. T. Branigan JTB
J. T. Branigan 'A'

REVIEWED BY: A. Besette AB
Besette

G. P. Thacker
Approved: G. P. Thacker
520-76

APPROVED BY: J. T. Mackey
J. T. Mackey Section Head
Microwave and Antennas 'A'

(R) 2-16-76

1.0 INTRODUCTION

1.1 This memorandum establishes the test procedure to check insertion loss of the Phoenix Track and Search Radomes, Drawings 2923532 and 3161017 respectfully.

2.0 TEST EQUIPMENT

2.1 The following test equipment or equivalent may be used:

<u>ITEM</u>	<u>MFR.</u>	<u>P/N</u>
IT		
Test Fixtures	G.D./P	SK223-081064 and SK223-081065
TWT	Hughes	11779/Ku-001
Isolator	E & M	Ku-0110 LI
Directional Coupler (2)	H.P.	P752 D
R.F. Generator	H.P.	8690A, 86954
VSWR Indicator	H.P.	415'
Frequency Meter	H.P.	P532 A
W/G Termination	H.P.	P914 A
Precision Attenuator	H.P.	P382 A
W/G to Coax Adapter	H.P.	P281 B
Pattern Recorder	Scientific Atlanta	SA 1520
Graph Paper	Scientific Atlanta	128
Bolometer	PRD	627-A
Track Antenna	G.D./P	2923532
Search Antenna	G.D./P	3161017

2.2 The test will be performed on the antenna test range.

3.0 TEST PROCEDURE

3.1 Connect the Antenna (Search or Track) per Figure 1.

3.2 Utilizing the pattern recorder as an aid, position the antenna for the optimum peak signal level at Boresight for both Azimuth and Elevation planes at F_L (Reference a).

3.3 Adjust the precision attenuator for a convenient reference signal level indication on the HP 415 and note both attenuator and meter settings.

3.4 Install the proper Radome over the Antenna being used in the test set up in Figure 1.

3.5 Adjust the signal level indication on the HP 415 up to the reference established in 3.3 by adjusting the precision attenuator. Determine the Insertion Loss by calculating the difference between reference setting noted in 3.3 and the new setting on the precision attenuator. Record the Insertion Loss on the data sheet.

3.6 Repeat 3.2 through 3.5 for F_0 and F_H (Reference a).

"A"

4.0 DATA PREPARATION

4.1 Data sheets will be provided. Make all entries in ink.

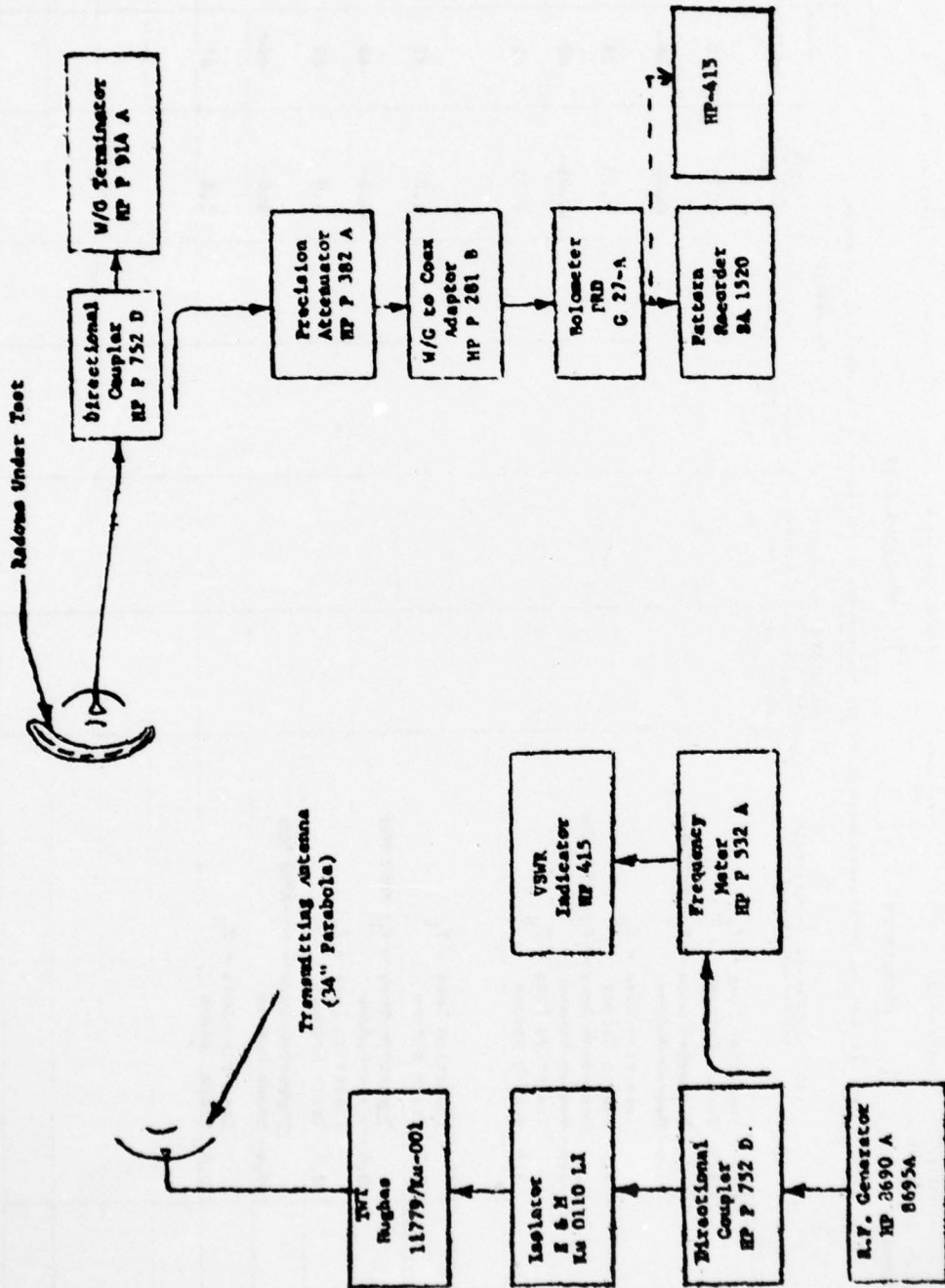

Figure 1

GENERAL DYNAMICS

DATA RECORD SHEET - TEST RUN PARAMETERS DATA

NAME OF UNIT TESTED: Search or Track Radomes
 TYPE OF TEST: Acceptance
 PROCEDURE ASS'N: M6-223-9.8-89
 SHEET 1 OF 1
 D FORM 487 (REV 1)

CD CLASS NO.	PROCEDURE PARAGRAPH REFERENCE AND PARAMETER NAME	INDICATOR OR CALCULATION REQUIRED OR TEST NO.	NOMINAL VALUE	PARAMETER		UNITS	A B C J
				LOWER MOST NEG. TOLERANCE LIMIT	UPPER MOST POS. TOLERANCE LIMIT		
	3.5 Search Radome Insertion Loss - F _L Insertion Loss - F_L -1050-1812			0.75	0.75	dB	"A"
	3.6 Search Radome Insertion Loss - F₀ -Insertion Loss - F₀ -1050-1812			0.75	0.75	dB	"A"
	3.6 Search Radome Insertion Loss - F _H Insertion Loss - F_H -1050-1812			0.75	0.75	dB	"A"
	3.5 Track Radome Insertion Loss - F _L Insertion Loss - F_L -1050-1812			1.0	1.0	dB	"A"
	3.6 Track Radome Insertion Loss - F₀ -Insertion Loss - F₀ -1050-1812			1.0	1.0	dB	"A"
	3.6 Track Radome Insertion Loss - F _H Insertion Loss - F_H -1050-1812			1.0	1.0	dB	"A"

M6-223-9.8-89 "A"
Page A

AD-A068 672

GENERAL DYNAMICS/POMONA CALIF POMONA DIV
FOAM-FILLED FIBERGLASS RADOMES.(U)
MAR 79 W L MACTURK

F/G 11/5

UNCLASSIFIED

M-24-6-678

NAVSEA-MT-100

N66001-77-C-0139

NL

2 OF 3

AD
A068672



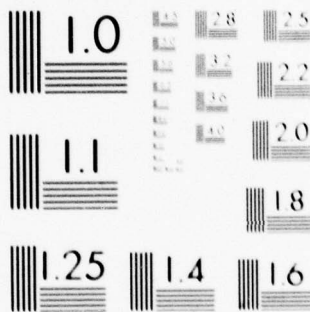

MICROCOPY RESOLUTION TEST CHART
NATIONAL BUREAU OF STANDARDS-1963-A

CDRL A003
Code Ident 9243
M-24-6-678

APPENDIX D

SURFACE FINISH OF RADOME

CERTIFICATE OF COMPLIANCE

DATE: 27 June 1978

TO: W. L. MacTurk Dept. 24-6

IT IS HEREBY CERTIFIED THAT THE MATERIAL DESCRIBED HEREIN HAS BEEN INSPECTED FOR SURFACE FINISH REQUIREMENT ONLY.

Radome was checked on Bendix Profilometer Model #4, micro finish reads from 3 to 6, the required is 20 micro finish. Calibration on equipment is not due until 3 February 1979.

DESCRIPTION 40" Diameter Naval Hemispherical Radome			
PART NUMBER 5188237	REVISION -	PURCHASE ORDER NUMBER -	PACKING SHEET NUMBER -
OTHER DOCUMENTATION Contract N66001-77-C-0139 WJC			

BY: *M. Williams* (GD 11 2)
 (AUTHORIZED SIGNATURE)

NAME: *H. J. Stave*

TITLE: INSPECTION CHIEF
 QUALITY CONTROL DEPARTMENT
 GENERAL DYNAMICS, POMONA

CDRL A003
Code Ident 9243
M-24-6-678

APPENDIX E

THERMAL TRANSMISSION - SOLAR RADIATION

GENERAL DYNAMICS
Pomona Division

TM 24-6-772
MODEL Naval Search Radome
CONTRACT N66011-77-C-0139

TECHNICAL MEMORANDUM

DATE: 11 July 1978
TO: Mr. John Markall N.O.S.C. San Diego, CA.
FROM: Advanced Manufacturing Technology Dept. 24-6

SUBJECT:
Thermal Transmission - Solar Radiation

REFERENCE:

DISTRIBUTION:
LIBRARY

PREPARED BY: W. L. MacTurk
W. L. MacTurk

PREPARED BY: _____

REVIEWED BY: _____

APPROVED BY: M. C. Abrams
M. C. Abrams

GENERAL DYNAMICS

Pomona Division

CDRL A002
Code Ident 9243
M-24-6-678

SOLAR RADIATION TESTS

To determine interior temperature differences between a vendor fiberglass honeycomb design and the fiberglass-foam design when exposed to direct sunlight, one hemispherical radome of each design was placed in direct sunlight and the temperature monitored with a digital thermometer over a period of 38 hours.

A thermocouple was placed in the interior of each dome 4.5" up from each base and at the center of origin of each dome. A third thermocouple was placed on the outside of one dome at the apex and monitored the outside temperature. The three thermocouples were connected to a digital thermometer and temperature readings taken every half hour beginning at 7:00 am and continuing through a 38-hour period of 9:30 pm the following night. Due to the low thermal conductivity of the foam, the fiberglass/foam radome recorded the lowest temperature readings and at 1:00 pm of each day when the highest outside temperatures were recorded read as follows, outside temperature 118^oF; fiberglass honeycomb design 109^oF; and fiberglass/foam design 103^oF. For the second day these temperatures read 118^oF, 114^oF and 110^oF respectively. Average day light temperature difference between domes was 5 F. During night time the dome cooled rapidly, the honeycomb losing heat faster than the foam radome. At the lowest outside temperature of 52^oF recorded at 4:30 am., the honeycomb interior was 54 F and the foam radome 57^oF. At 6:30 am all three temperatures were identical and recorded 61^oF.

To insulate the base of each radome from the ambient temperature each radome base was encased in a solid circular foam structure, the foam being grooved to accept the 40" diameter radomes. Thermocouple leads ran through holes drilled through the edges of the foam bases and up into the interior of the radomes.

Figure 1 shows a graph of the temperature conditions in the interior of each radome and the ambient temperature over the 38 hour period that monitoring took place. The thin foam cross section of the polyester glass radome (average thickness .200") although superior to the vendor honeycomb as a cooler temperature shield inhibits the large temperature difference one would expect when comparing the thermal conductivity of foam versus honeycomb.

At the hottest part of the day where solar radiation generates 93 watts/ft² over the surface of the radome Q the quantity of heat flow in BTU's/Hr from the foam radome would be 289.

From the basic heat flow equation, the temperature difference between ambient and the interior of the radome would be,

$$\begin{aligned} dt &= \frac{Q}{KA} dx \\ &= \frac{289}{0.18 \times 21.4} \cdot .200 = 15^{\circ}\text{F} \end{aligned}$$

where dt = Temperature difference (t₂ - t₁)^oF
Q = Quantity of heat flow BTU/HR/FT²/IN/^oF
K = Thermal conductivity of core = .18
A = Area of surface (ft²) radome
dx = Thickness of foam core of radome (inches)

As the equation shows the thickness of the radome becomes significant in providing a cooler radome interior. One proposal on a new search radome for an upcoming program is to increase the thickness of the foam core to a half-wavelength (.550"). This would provide a temperature difference from ambient of,

$$\begin{aligned} dt &= \frac{Q}{KA} dx \\ &= 38^{\circ}\text{F} \end{aligned}$$

and would be a significant decrease in interior radome temperature in equatorial climates or conversely a means of providing thermal insulation in polar regions.

SOLAR RADIATION TEST - HONEYCOMB VS FOAM RADOME

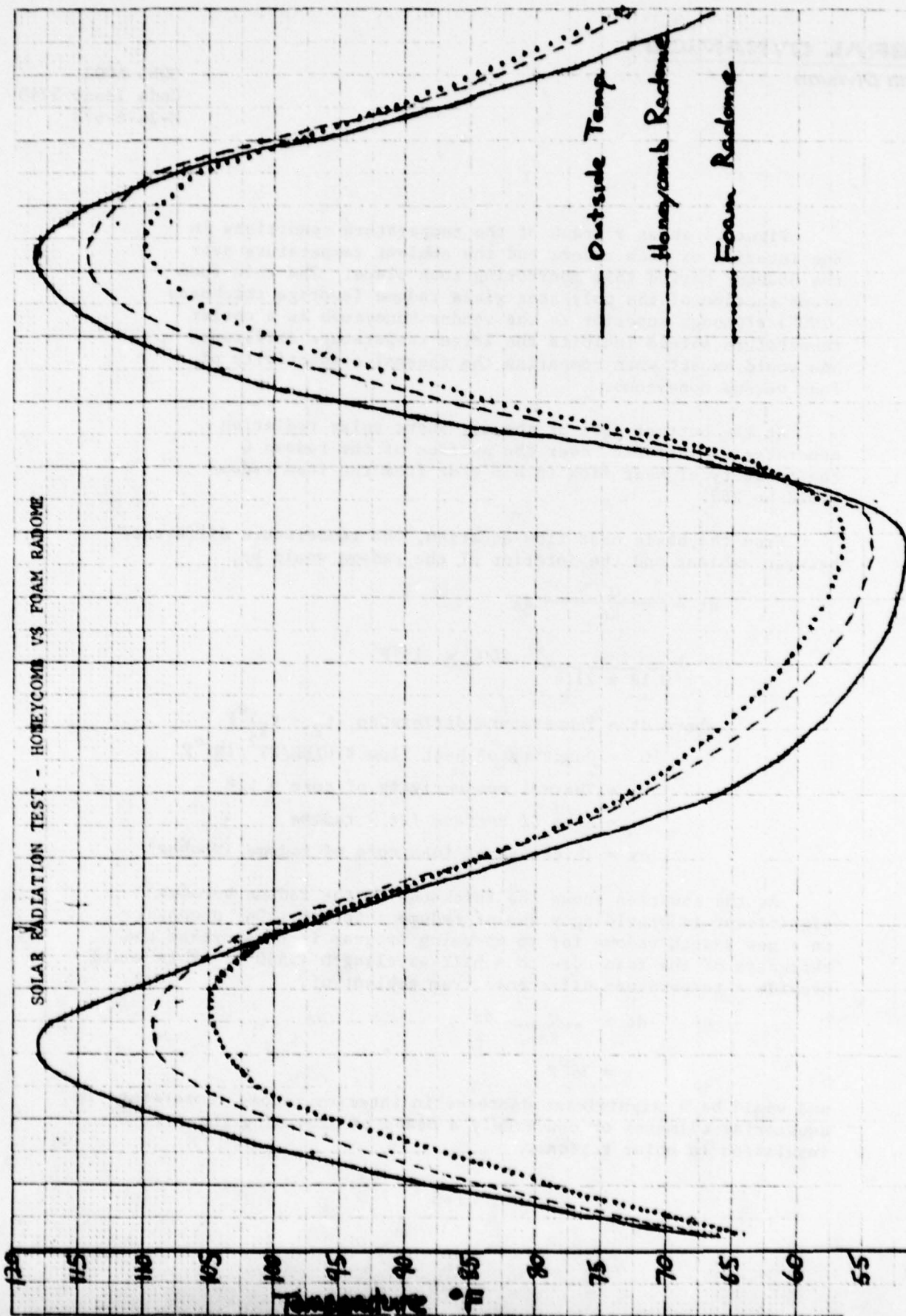

7 AM 9 AM 11 AM 1 PM 3 PM 5 PM 7 PM 9 PM 11 PM 1 PM 3 PM 5 PM 7 PM 9 PM

21 July 1977 22 July 1977

FIGURE 1

CDRL A003
Code Ident 9243
M-24-6-678

APPENDIX F

ICE RETENTION ON RADOME

GENERAL DYNAMICS
Pomona Division

TECHNICAL MEMORANDUM

TM
24-6-773
MODEL
Naval Search Radome
CONTRACT
N66011-77-C-0139

DATE: 11 July 1978

TO: Mr. John Markall, N.O.S.C. San Diego, CA.

FROM: Advanced Manufacturing Technology Dept. 24-6

SUBJECT: Ice Retention on Radome

REFERENCE: GD/PD-MTR75/046
GD/PD-MTR77/055

DISTRIBUTION:
LIBRARY

PREPARED BY: W. L. MacTurk
W. L. MacTurk

PREPARED BY: _____

REVIEWED BY: _____

APPROVED BY: M. C. Abrams
M. C. Abrams

GENERAL DYNAMICS

Pomona Division

CDRL A002
Code Ident 9243
M-24-6-678

Ice Formation/Retention Properties of Exterior Facing -

Search Radome

An important consideration which must be looked at is the attenuation of microwave energy of the system due to ice build up. Conventional radome manufacture utilizing hand-laid honeycomb core and epoxy-glass facings results in an extremely rough and porous surface, allowing condensation and retention of water vapor and subsequent ice formation. To combat this effect, a vacuum impregnation technique to deposit a low-friction TFE coating to the radome surface was developed by certain manufacturers and later discarded due to the high cost (1/3 of the total radome expense) of the material and the equipment to apply it.

With the molded polyester-fiberglass approach, surface finish is better than 20^μ inches as removed from the mold. Subsequent waxing and polishing further reduces the coefficient of friction, and finishes as low as 5^μ inches have been achieved. Experiments conducted by Advanced Manufacturing Technology in spraying freezing sea-water onto a cold radome surface (-20°F) and allowing a build up of sea ice to a thickness of 0.4" by repeated sprayings showed that the ice could be easily removed with gentle tapping and in many cases could be removed by a fore finger.

The first experiment was conducted as follows:

A 19" diameter hemispherical radome utilizing gel coated polyester glass facings and a rigid foam core to the same thicknesses as the 40" diameter search radome and identical in materials and construction was placed in a large box insulated with foam and containing dry ice.

Sea water taken from the Catalina channel was chilled to 35°F (temperature of most seas in the polar regions) and sprayed onto the exterior of the radome whose temperature had reached -20°F. After successive sprayings of sea water until the ice thickness approximated 0.5 inches, the radome was allowed to remain in the CO₂ box until a temperature of -40°F had been reached.

GENERAL DYNAMICS

Pomona Division

CDRL A002
Code Ident 9243
M-24-6-678

The radome was then removed from the CO₂ box and gently tapped with a 12" wooden ruler, which caused 80% of the ice formation to fall from the radome.

Tests conducted for the Program Office (who witnessed this experiment) by engineering group Dept. 2 on a honeycomb radome purchased for the Phalanx program could not remove ice from the radome using de-icing solutions (alcohol-glycol formulations). Physical force used to remove the ice led to laceration of the honeycomb dome and the vendor on contact proposed that a new program leading to a better finish be instituted.

Department 24-6 Manufacturing Technology carrying through with their proposed foam radome ran two simple tests in 1977 to determine ice retention capabilities on a conventional honeycomb core with epoxy facings, and a foam core with gel coated polyester glass facings. Two flat samples 12" x 8" x .5" were prepared, one sample simulating the honeycomb core epoxy facing and the other simulating the 5 μ inch finish of Manufacturing Technology's gel-coated polyester glass/foam radome.

Two blocks of sea ice (4" x 3.1" x 1") were frozen in a box of CO₂ and then bonded with sea water to the surface of the flat samples. A calibrated Cal Tester was used to shear the sea ice blocks from the samples in question and the force required to remove the ice was recorded. The results were as follows:

<u>Polyester Glass/Foam Sample</u>	<u>Epoxy Glass/Honeycomb Sample</u>
Temperature = -20 ^o F	-20 ^o F
Area of bond = 12.4 in ²	12.4 in ²
Force required to shear ice from sample = 27.6 lbs	180 lbs
Bond strength = $\frac{27.6}{12.4} = 2.22$ psi	14.52 psi

From the above table, it can be seen that a force 5.6 times greater was required to remove the sea ice from the honeycomb sample than from that of the foam core sample and is attributed to the large difference in surface finish between samples.

GENERAL DYNAMICS

Pomona Division

CDRL A002
Code Ident 9243
M-24-6-678

Although this test is valid for the foam core/gel coated polyester glass sample it is doubtful that the test is conclusive for the honeycomb core sample. Here the honeycomb was bonded to the epoxy glass facings which were layed up over a smooth aluminum plate and had a finish which could not be simulated on the rough irregular surface of the epoxy honeycomb radome surface. Honeycomb "bleed through" had still not occurred on the sample and had a smoothness much finer than the radome.

Although not conclusive the tests do show that surface finish and therefore ice retention can pose serious problems in honeycomb structures built in the conventional manner.

CDRL A003
Code Ident 9243
M-24-6-678

APPENDIX G

ACOUSTIC ISOLATION - INSERTION LOSS

GENERAL DYNAMICS

Pomona Division

AVO

DATE: 13 June 1978
TO: W. L. MacTurk - MZ 4-26
FROM: Structural Dynamics - R. Strike
SUBJECT: Sound Transmission Loss Characteristics as Projected
for a 40 inch Diameter Radome

Measured small panel insertion loss data and computed transmission loss trend lines are provided for a sandwich radome consisting of two glass fiber reinforced polyester skins fixed to a 9 pound per cubic foot foam core.

Table 1 lists pertinent boundary conditions and material characteristics for the radome and the small test panel. Figure 1 shows the empirical result for a 9.0 inch diameter clamped flat panel with the low frequency (stiffness controlled) and high frequency (mass controlled) trend lines for the radome. The empirical data with one-third octave frequency resolution are in good agreement with the computed result with respect to the eigenfrequency value and in fair agreement with respect to transmission loss magnitudes. The fact that the panel provides less than mass law attenuation at high frequency is consistent with results for other foam sandwich and honeycomb core panels.

The low frequency trend lines compare closely for the two configurations as the double curvature of the larger panel more than compensates for its increased size and the different boundary conditions. The empirical results are not considered reliable below 500 Hz due to flanking paths from source to receiving chambers. However, the computed and measured data exhibit similar slopes. The empirical transmission loss dip at 1 KHz relative to the stiffness controlled trend line can be used to estimate modal damping.

The coincidence frequency noted on Figure 1 indicates the frequency at which a whole panel flexural wave propagates at 344 meters per second (sonic velocity in air). Again, due to relatively high panel damping the "dip" near the coincidence frequency is not significant.

Prepared by

R. Strike

R. Strike

Approved by

D. A. Underhill

D. A. Underhill
Section Head
Structural Dynamics

cc: W. H. Terrill

TABLE 1
MATERIAL PROPERTIES

CHARACTERISTIC	PANEL CONFIGURATION 40 INCH DIAMETER HEMISPHERICAL DOME 9.0 INCH DIAMETER PLATE		UNITS*
Edge Support	Simple	Clamped	-
Shell Thickness	6.71×10^{-3}	6.71×10^{-3}	m
Radius	0.505	0.114	m
Average Density	386	386	kpm ⁻³
Surface Density	2.59	2.59	kpm ⁻²
Shear Modulus	2.92×10^9	2.92×10^9	Pa
Poisson Ratio	0	0	-
Lowest Eigenfrequency	970	940	Hz
Effective Surface Stiffness	9.6×10^7	9.0×10^7	Pam ⁻¹

*Meter-kilogram-second system: m = meter, kp = kilogram, Pa = Pascal = Newton per square meter and Hz = Hertz

TABLE 2

PERTINENT DEFINITIONS

Transmission Loss:

Difference between incident and transmitted sound intensities:

$$T.L. = -10 \log_{10} \frac{|P_t|^2}{|P_i|^2}, \text{ decibels (dB)}$$

Insertion Loss:

Difference between received intensities as measured with and without a given sound partition. In the classic plane progressive wave case only the source side reflection is counted:

$$I.L. = T.L. - R_S \approx T.L. - 6 \text{ dB}$$

Noise Reduction:

Difference between received intensities as measured with or without any noise control. Source and receiver side reverberation effects are taken into account:

$$N.R. = T.L. - R_S - R_R$$

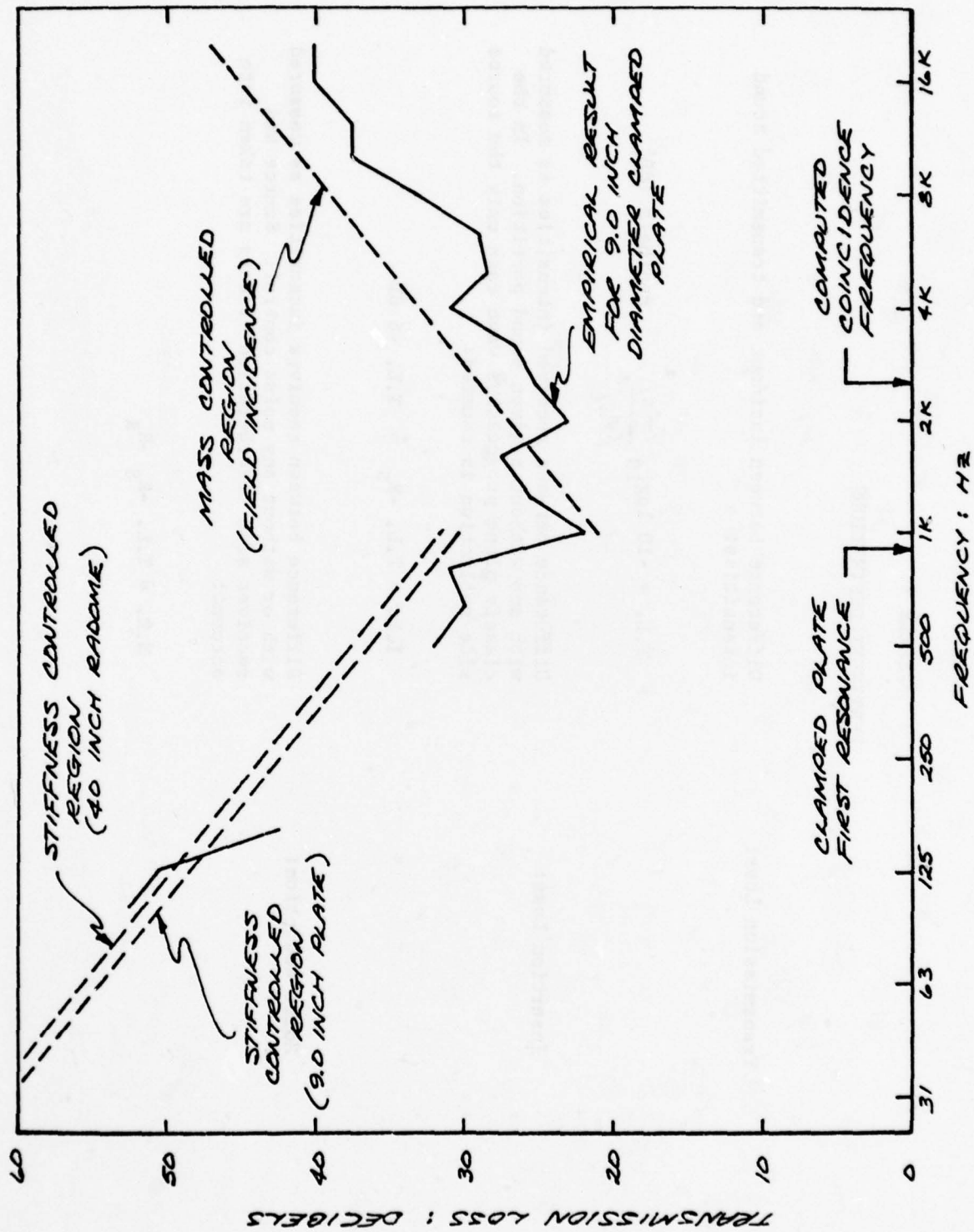

FIGURE 1 RADOME ACOUSTIC TRANSMISSION LOSS

CDRL A003
Code Ident 9243
M-24-6-678

APPENDIX H

STATIC PROPERTIES OF FOAM CORE/FACINGS

GENERAL DYNAMICS
Pomona Division

TECHNICAL MEMORANDUM

TM
6-348-62.39-12
MODEL PHALANX
CONTRACT

DATE: 15 May 1978

TO: Distribution

FROM: Structural Dynamics - Section 348

SUBJECT: MECHANICAL PROPERTIES AND FATIGUE LIFE ESTIMATES OF
FOAM CORE FIBERGLASS SANDWICH RADOMES FOR PHALANX

REFERENCE:

See Page 13

- DISTRIBUTION:
- LIBRARY (5)
- Hiroshige, K. 4-45
 - Abrams, M. 4-26
 - MacTurk, W. L. 4-26
 - Pugliese, D. A. 4-38
 - Rizley, J. H. 4-56
 - Stanley, G. E. 4-17
 - Hildebrandt, C.R. 4-17

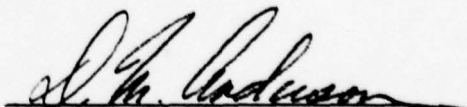
PREPARED BY: 
D. M. Anderson

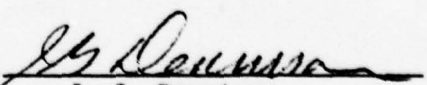
Reviewed BY: 
J. G. Dennison

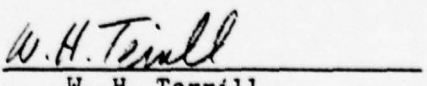
REVIEWED BY: 
W. H. Terrill

APPROVED BY: 
D. A. Underhill

Section Head - Structural Dynamics
10) FORM 6-660 RT

TABLE OF CONTENTS

Section		Page
1	Summary	1
2	Introduction	2
3	Material Properties	3
4	Static Bend Tests	4
5	Fatigue Testing	5
6	Fatigue Analysis and Life Estimate	6
7	Search Radome	11
8	Conclusions	12
9	References	13

Section 1
SUMMARY

Phalanx track radome material, a composite sandwich of fiberglass facings with polyurethane foam core, is evaluated by static tests and fatigue testing. Static tests include facing tension, core shear and compression, and composite bending. Results are summarized in Table 1. Failure mode in bending and in fatigue testing is by core shear failure.

Fatigue testing is by bending specimens cut from a track radome, using a 4-point fixture for sinusoidal loading with stress ratio zero. Fatigue results are presented in the S/N curve of Figure 7. To estimate fatigue life under acoustic loading, dynamic response is assumed to follow that of an aluminum skin foam core panel as previously measured in the vicinity of GAU-8 30 mm firing and reported in Reference 2. Test panel response is suitably scaled to account for differences in acoustic pressure, panel compliance, mass, size, and curvature. Such scaling introduces considerable uncertainties, but approximations are chosen conservatively. Allowance is also made to account for seawater spray environment, and a 95% confidence factor for design. The resulting fatigue life estimate is more than 4 times the required life of 240,000 rounds for the track radome, and considerably greater for the search radome.

Section 2
INTRODUCTION

The CIWS radomes are subject to acoustic loading over a projected life of 240,000 rounds fired from the Phalanx 20 mm gun. Radome material is foam core fiberglass sandwich. Each facing is two layers of fiberglass cloth, thickness 0.035" including gel coat. Core is foamed-in-place rigid polyurethane, of nominal density 5 lb/ft³. This density is obtained using nominal 2 lb/ft³ density foaming material in a confined volume, resulting in a rind of increased density at each bond surface. Overall thickness of the sandwich is 0.62" for the cylindrical (track) radome and .30 for the hemispherical (search) radome. Exterior radius of curvature for both the cylindrical and hemispherical radomes is 20 inches.

In order to evaluate radome durability in the acoustic environment, fatigue tests in bending were performed on 5" x 13.5" specimens cut from a cylindrical radome (see Reference 1). The fatigue testing was preceded by a series of material property tests. Results of both static and fatigue testing are reported herein. Fatigue life estimates for gunfire acoustic loading are determined with reference to previously measured response of foam core aluminum skin panels in the vicinity of the GAU-8 30 mm (see Reference 2).

Section 3
MATERIAL PROPERTIES

Reference 1 describes material test methods and specimens used to determine selected mechanical properties of the foam core sandwich, the core, and the facings. Testing methods used were in conformance with MIL-STD-401B. Tests of core tension and shear were performed for both unbonded (i.e., self adhesion of foamed-in-place core to the fiberglass facings) and adhesively bonded specimens.

Results of static testing are summarized in Table 1. Each value is the average of at least four tests. Overall, testing repeatability had a standard deviation of $\pm 7.0\%$.

Typical load-deformation curves are shown for various specimens; core shear in Figure 1, core compression in Figure 2, and core tension in Figure 3.

Section 4
STATIC BEND TESTS

Static bend testing was performed on specimens identical to those used for the (bending) fatigue testing. This testing used the same fixture as in the fatigue testing. Specimens are cut from a Phalanx track radome, each specimen 13.5" x 5.0" with the axis of cylindrical curvature (20" radius) of the radome on the transverse axis. The central 3.0" of the specimens is reduced to 4.7" width, and a 1" x 5" aluminum alloy boss is bonded into each end, in place of the foam core, to provide compression strength for the end grip region. Figure 4 shows a specimen under extreme loading in the fixture.

The fixture induces 4-point bend, with 12.5" between fixed end clamps and 3.0" between moving central clamps.

Figures 4 and 5 show the set-up at the point of maximum deflection where the load reaches ultimate as core shear failure progresses. The corresponding load-deflection curves are illustrated in Figure 6. The failure mode is core shear, as predicted by standard laminate stress analysis. Based on tested core shear strength of 40 psi, ultimate core shear failure is expected to occur at about 240 lb for the bend specimens. In some cases ultimate strength is lower, probably resulting from the stress concentrations caused by the fixture.

Section 5
FATIGUE TESTING

Fatigue testing was conducted by the Materials Research group, Convair Aerospace, Kearny Mesa, San Diego. Specimens and loading fixture were the same as used in the static bend testing.

All fatigue testing was with sinusoidal loading at a stress ratio $R = 0$, i.e., minima at nominally zero load. Load frequency was at 30 Hz.

Considerable experimentation was required in order to establish a reliable failure criterion. The dominant mode of failure is shear fracture of the foam core, in some cases accompanied by delamination at a facing. Failure criterion chosen was a threshold compliance, set to shut off loading on the basis of an extreme deflection.

Using this threshold on excess bending compliance as a failure criterion, fatigue life was determined for 14 successful tests. On two of these tests, at high loading (170 and 200 lb), noticeable delamination or cracking of the foam core occurred prior to reaching the compliance threshold. These two points are included on the S/N curve obtained, shown in Figure 7. The data scatter is no more than would be expected, considering the nature of the material.

Section 6
FATIGUE ANALYSIS AND LIFE ESTIMATE

Results of fatigue testing are used to estimate radome fatigue life by applying the S/N curve for the radome material to measured panel response to acoustic blast loading by 30 mm gunfire, suitably scaled to account for the effects described below. Each of these effects requires certain assumptions, including the validity of scaling over the range considered. A certain amount of judgement, based upon experience, is required in selecting appropriate analytical methods. Where choices exist in approximations, the more conservative selection was used throughout.

1. Utilize measured strain response of an aluminum skin foam core test panel exposed to acoustic loading in the vicinity of 30 mm firing. Reference 2 describes 30 mm test results for various panels. (Used herein, subscript t designates such test results.) It is assumed that a flat plate of radome sandwich material with the same planar dimensions as the test plate would be subject to a linearly scaled value of the same pressure forcing function and would have the same strain response except for linear scaling. Figure 8 (adapted from Figure 20 of Reference 2) shows the strain response spectrum, a probability distribution of the occurrence of strain magnitudes as measured at the most sensitive location on the facing of the test panel.
2. Reduce response stress to account for the acoustic loading of a 20 mm instead of a 30 mm gun. Reference 4 shows free field pressures along the radome location of 1.1 to 0.7 psi for the 20 mm gun and 1.4 to 0.8 psi for the 30 mm gun. Thus the peak overpressures for the two guns are nearly the same. However, the blast impulse (calculated from Reference 5) for the 30 mm in this region is greater than the 20 mm

by almost a factor of two. For purposes of this analysis, a factor of 1/2 is chosen for scaling 30 mm response to the equivalent of 20 mm environment.

3. Reduce response stress to account for the difference in location with respect to the muzzle between the test panel and the radome. References 4 and 2 show the blast fields. A factor of 0.35 is chosen to conservatively relate this effect for the radome to the test panel.
4. Modify test panel results to account for the different response of the radome sandwich material due to its different compliance and mass density. For this parameter, assume equal planar size and shape for the test panel (aluminum facings, foam core) and a panel of radome material (fiberglass facings, foam core). Reference 6 gives facing stress response as

$$\sigma = 2\pi^{3/2} \frac{E c}{M a^2 \omega_n^{3/2}} \sqrt{\frac{\phi(\omega)}{\delta}} \quad (1)$$

where: E is facing modulus, C is panel half-thickness, M is mass area density (lb/in²), a is width (in), ω_n is natural frequency, δ is damping ratio, and $\phi(\omega)$ is the spectral pressure.

Natural frequency is determined by

$$\omega = \pi^2 \sqrt{\frac{K}{M}} \quad (\text{shape factor})$$

where K is the stiffness constant for the plate. The ratio of stiffness of the test panel (aluminum facings, foam core) to that of a panel of radome material (fiberglass facings, foam core) varies from 13.1 to 22.3 depending upon edge fixity. The ratio of mass densities is

$$M_t / M_r = 2.37$$

determined by weighing actual specimens. If the damping ratios of both plates are assumed to be the same, and subject to the same forcing function, a correction factor of 1.18 is obtained from equation (1), relating stress in the facing of a hypothetical plate of radome material to the stress in the tested panel of the same planar dimensions.

5. Modify results of paragraph 4. above to account for the actual (track) radome being (a) larger in size and (b) curved along one axis. Natural frequency varies in proportion to

$$\text{shape factor} = \left[\frac{1}{a^2} + \frac{1}{b^2} \right]$$

where a = width and b = length. Using the dimensions of radome and test panel ($a_t = 19.2$, $a_r = 41.9$, $b_t = 37.2$, $b_r = 48$), and since stress varies as the 3/2 power of natural frequency, a factor of 6.33 is obtained relating stress in the larger (radome) panel compared to the test-panel sized plate.

To account for radome curvature, the ratio of stress is curved to flat panels may be approximated (from Reference 7) by:

$$\frac{\sigma_{\text{curved}}}{\sigma_{\text{flat}}} = \left[1 + \frac{.006 a^2 b^2}{h^2 R^2 \left[\left(\frac{b}{a} \right)^2 + \left(\frac{a}{b} \right)^2 + .604 \right]} \right]^{-3/4} \times \left\{ 1 + \frac{.153 b^2 \left[\left(\frac{b}{a} \right)^2 + .034 \right]}{R h \left[\left(\frac{b}{a} \right)^2 + 9.62 \left(\frac{b}{a} \right)^2 + 1 \right]} \right\}$$

Where radius of curvature $R = 20$ inches and panel thickness $h = .585$ inches. This results in a correction factor of 0.301 to account for the cylindrical curvature.

6. Using the approximate factors described in preceding paragraphs to scale measured strain in gunfire acoustic environment, fatigue life is estimated for the track radome. Figure 8 shows the distribution of strain response levels measured in the aluminum facing, subject to 30 mm firing blast environment (Reference 2). Also shown are two additional abscissa scales: in terms of the number of standard deviations of the measured response data, and the equivalent core shear stress in the radome. The latter scale results from scaling for the effects described above. The same function is the ordinate of Figure 7, the experimental S/N curve determined in fatigue testing.

Note that the actual strain response does not follow a Rayleigh distribution (the curved line on Figure 8, which peaks at a one sigma value). This indicates considerable deviation from random noise, particularly at the high levels (around 3σ) of stress produced by the blast impingement; i.e., the relatively high probability of occurrence of the highest stress peaks is seen by comparison of the test results with the Rayleigh distribution curve in the 2σ to 4σ region.

In order to apply the stress peak distribution to the fatigue life behavior of the material, the Palmgren-Minor cumulative damage law

$$N = \left[\int_0^{\infty} \frac{P(s)}{N_i(s)} ds \right]^{-1} \quad (2)$$

is used. $P(s)$ is the probability density at a stress interval $(s, s+ds)$, $N_1(s)$ is the number of cycles to failure at stress level s , obtained from Figure 7, and N is the total number of cycles to failure. The number of rounds fired is 35/360 of the number of zero crossings of the measured strain response. Numerical integration was performed for equation (2), using Figures 7 and 8.

Adjustment is made to account for the detrimental effects of a seawater spray environment, and to give a 95% confidence level of survival (Figure 7 gives average life, rather than 95% confident life), as well as the scaling for effects described above. Resulting fatigue life estimate is

$$N = 1.04 \times 10^6 \text{ rounds.}$$

This is more than four times the required weapon life of 240,000 rounds.

Section 7
SEARCH RADOME

The search radome will suffer less fatigue damage than the track radome. This is because: (1) it will deform less under the same pressure, and (2) it is located farther from the muzzle and oriented more favorably with respect to the acoustic pressure waves.

Comparison of lateral pressure instability buckling for the track (cylindrical) and search (spherical) radomes was made using approximation methods of References 8 and 9. Shell theory formulas using an equivalent thickness

$$t_e = (6th^2)^{1/3}$$

for the shell to represent the actual composite (of facing thickness t and overall thickness h), were applied to both radomes. Composite sandwich handbook methods were also used. Both methods are only approximate, but results show about a factor of 6 greater critical pressure load for the hemispherical (search) radome.

Section 8
CONCLUSIONS

Fatigue life estimates for Phalanx radomes indicate a life of more than 4 times the service requirement of 240,000 rounds.

Static testing of the foam filled fiberglass radome composite specimens does not indicate a significant advantage of adhesively bonded facings over "naturally" bonded composites. However, some specimens without adhesive showed regions of poor bonding at the core-facing interface, and were omitted from the tests.

Failure mode in both static bending and fatigue is by core shear. This results in excessive compliance and collapse of the composite shell but no break or tear in the facings. Failure is usually preceded by cracking or crazing of the gel coat without significant change in strength being associated.

Section 9
REFERENCES

1. TM 6-348-62.39-7, "Test Plan: To Evaluate Fatigue Behavior and Material Properties of Foam Core Fiberglass Sandwich Radome Material," June 1977.
2. TM 6-348-62.19-7, "Phalanx Panel Fatigue Life Estimated from 30 mm Firing Tests," August 1976.
3. TM 6-348-62.57-1, "CIWS Pilotline Track Radome Structural Test Report," November 1977.
4. TM 348-62.19-2, "PHALANX: Gun Blast Definition Obtained During General Electric Level II Tests".
5. "The Blast Field About The Muzzle of Guns," by Peter S. Westine, Southwest Research Institute, San Antonio, Texas.
6. Osgood, Carl C., Fatigue Design, Wiley, 1970
7. AFFDL-TR-74-112, "Sonic Fatigue Design Guide for Military Aircraft," by Rudder, F. F., & Plumblee, H. E., May 1975.
8. AFAL-TR-66-391, Vol. 1, "Techniques for Airborne Radome Design," Air Force Avionics Lab, 1966.
9. MIL-HDBK-23A, "Structural Sandwich Composites".

TABLE 1

PROPERTY	FOAM CORE		FACING
	Unbonded	Bonded	
Density (lb/ft ³)	4.77		
Tensile Strength (psi)	66.3	66.9	14800
Tensile Modulus (ksi)	1.44	1.92	1050
Compressive Strength (psi)		33.8	
Compressive Modulus (psi)		1496	
Shear Strength (psi)	45.4	40.8	
Shear Modulus (psi)	520	493	

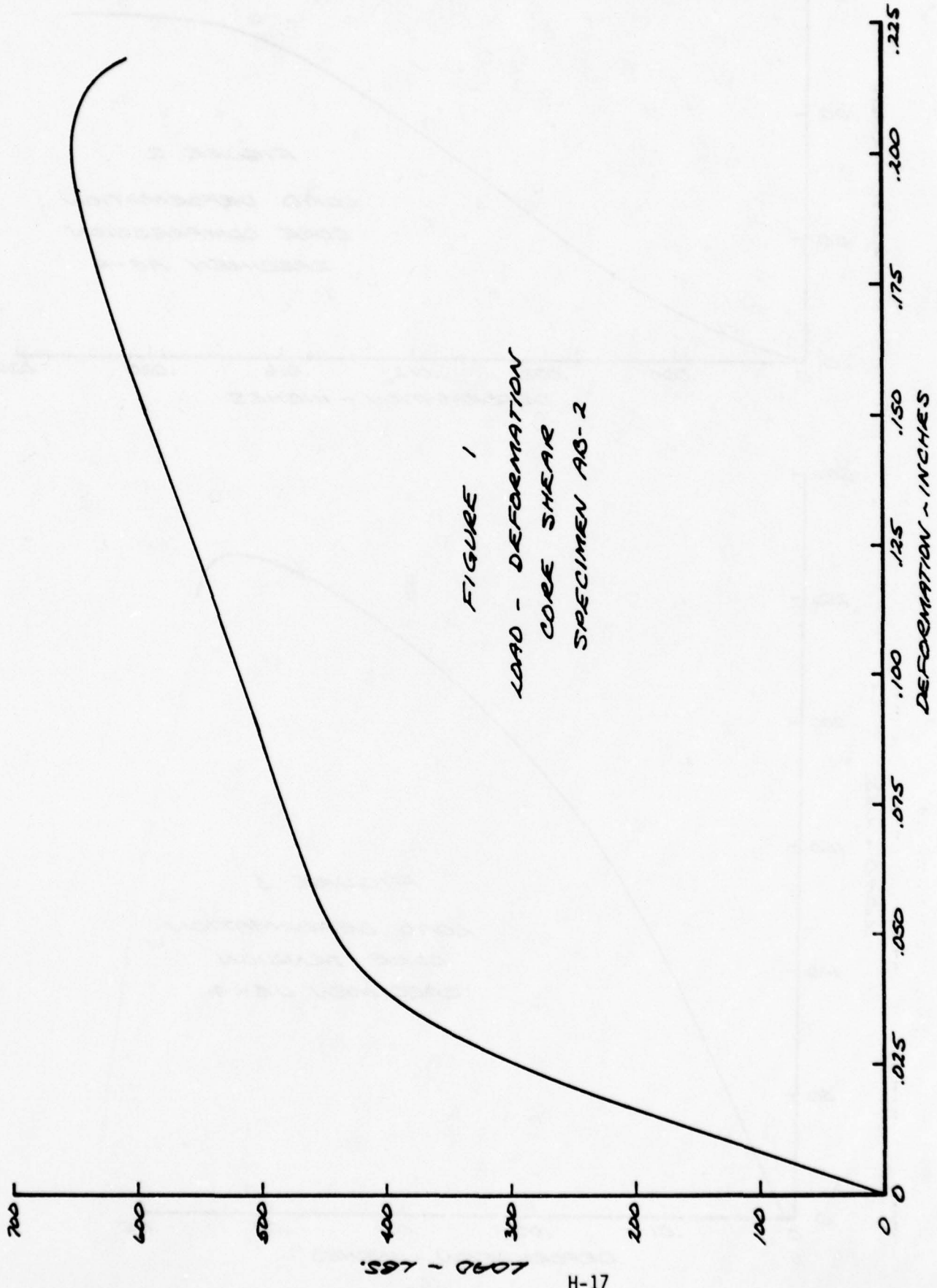
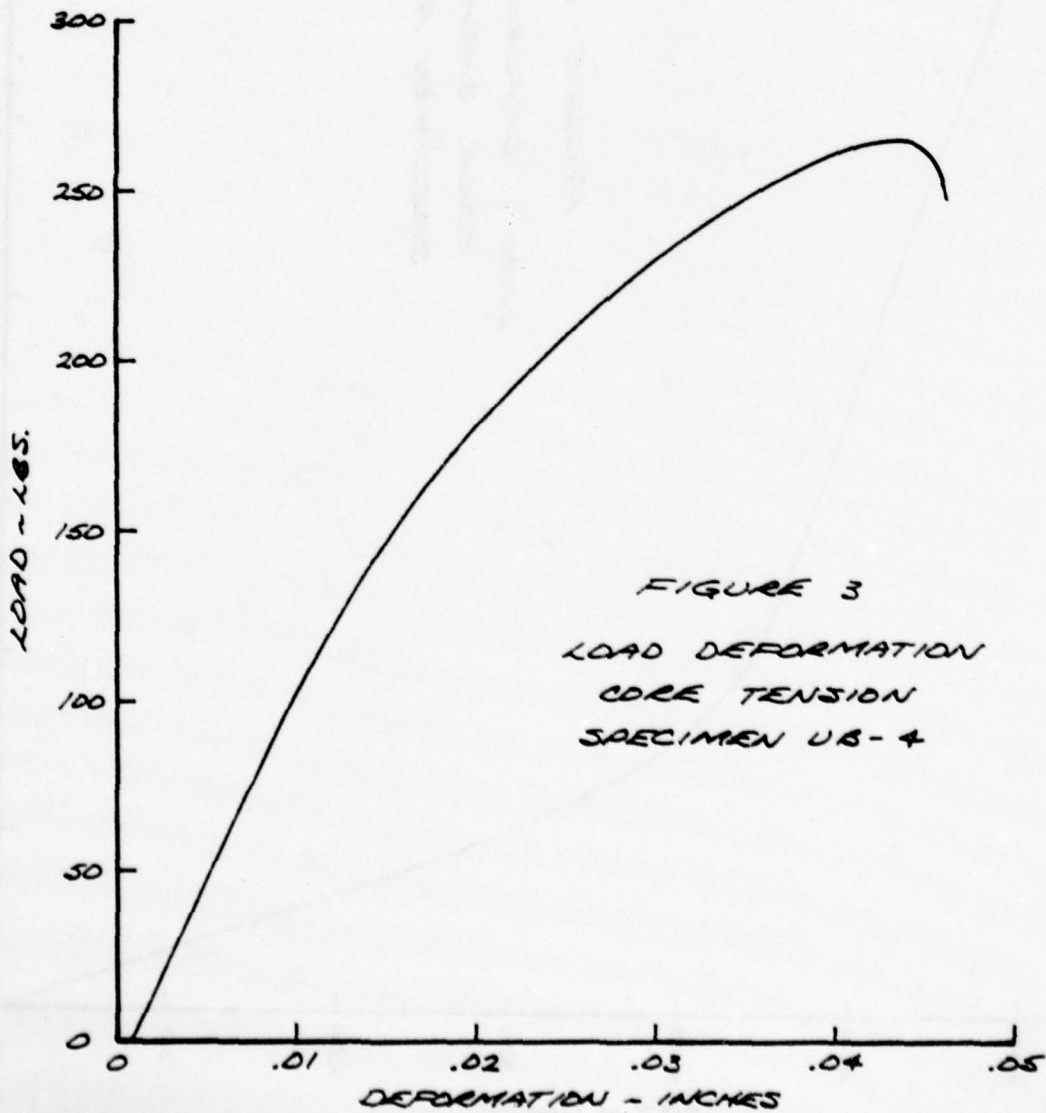
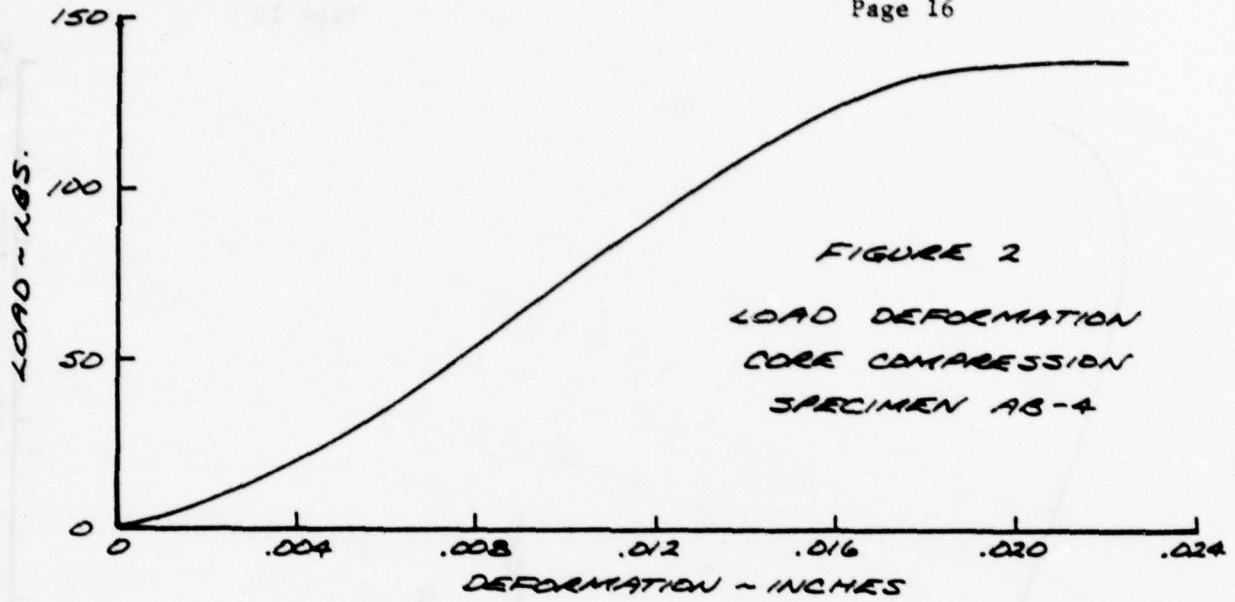

FIGURE 1
LOAD - DEFORMATION
CORE SHEAR
SPECIMEN AS-2



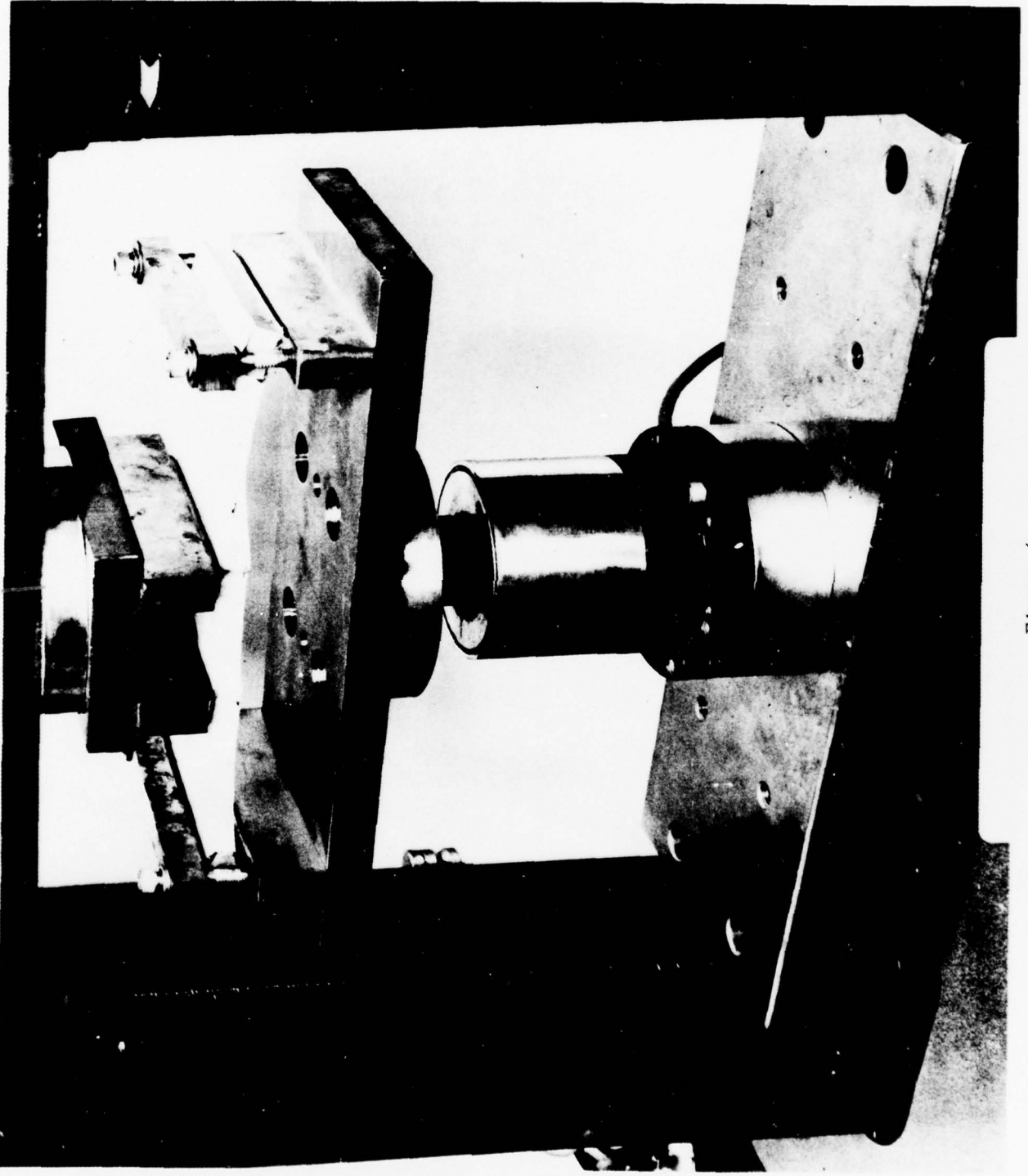
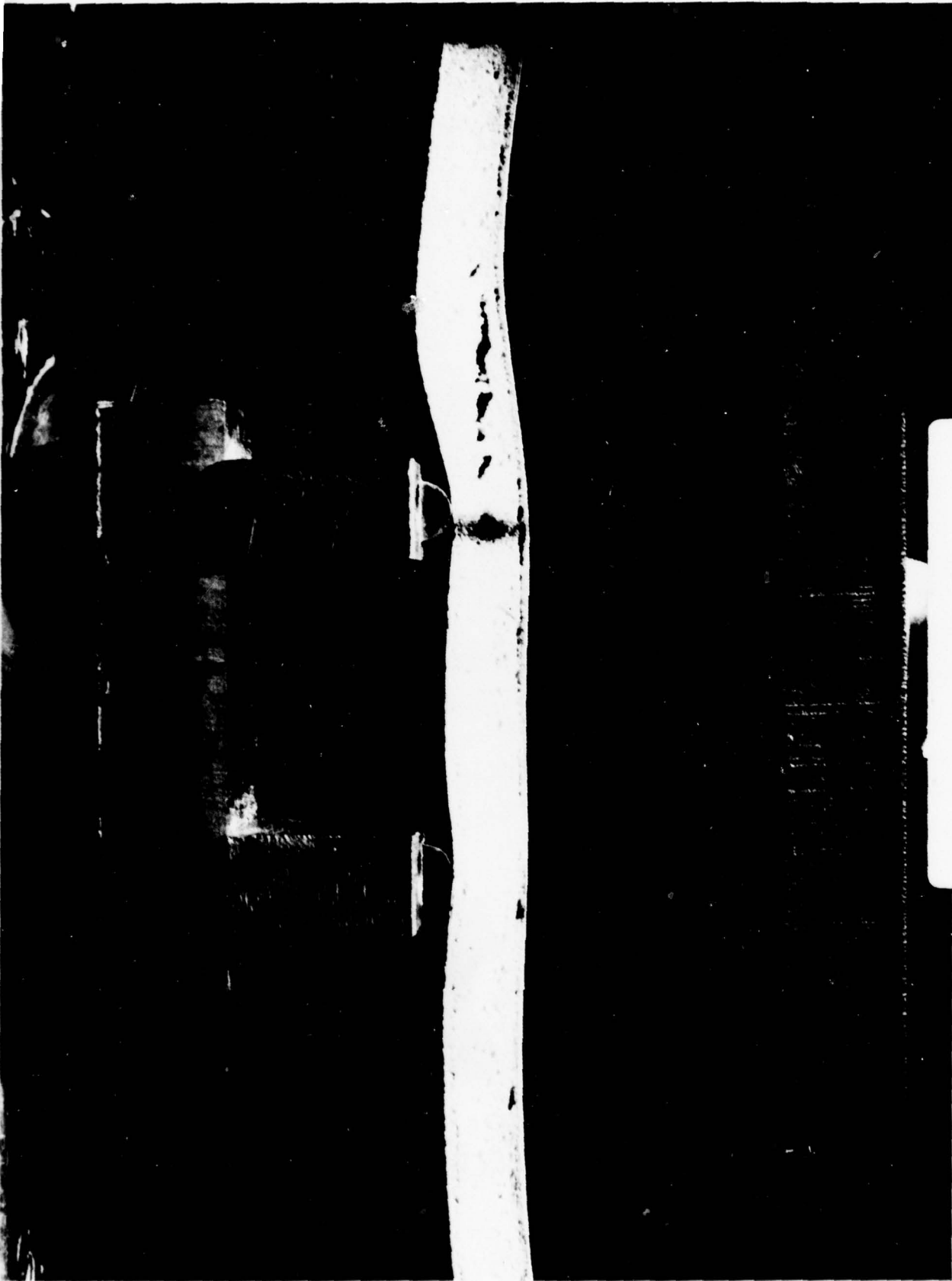

Figure 4

PHALANX FOAM SANDWICH RADOME
BEND TEST SETUP

JEN...AL.../NA...CS
Pomona Division

P.O. 5-78-81534



H-20

PHALANX FOAM SANDWICH RADOME
ALUMINUM FIBER

Figure 5

PL 5-78-1575

FIGURE 6
BEND TESTS
PARALANX TRACK RADOME MATERIAL SPECIMENS

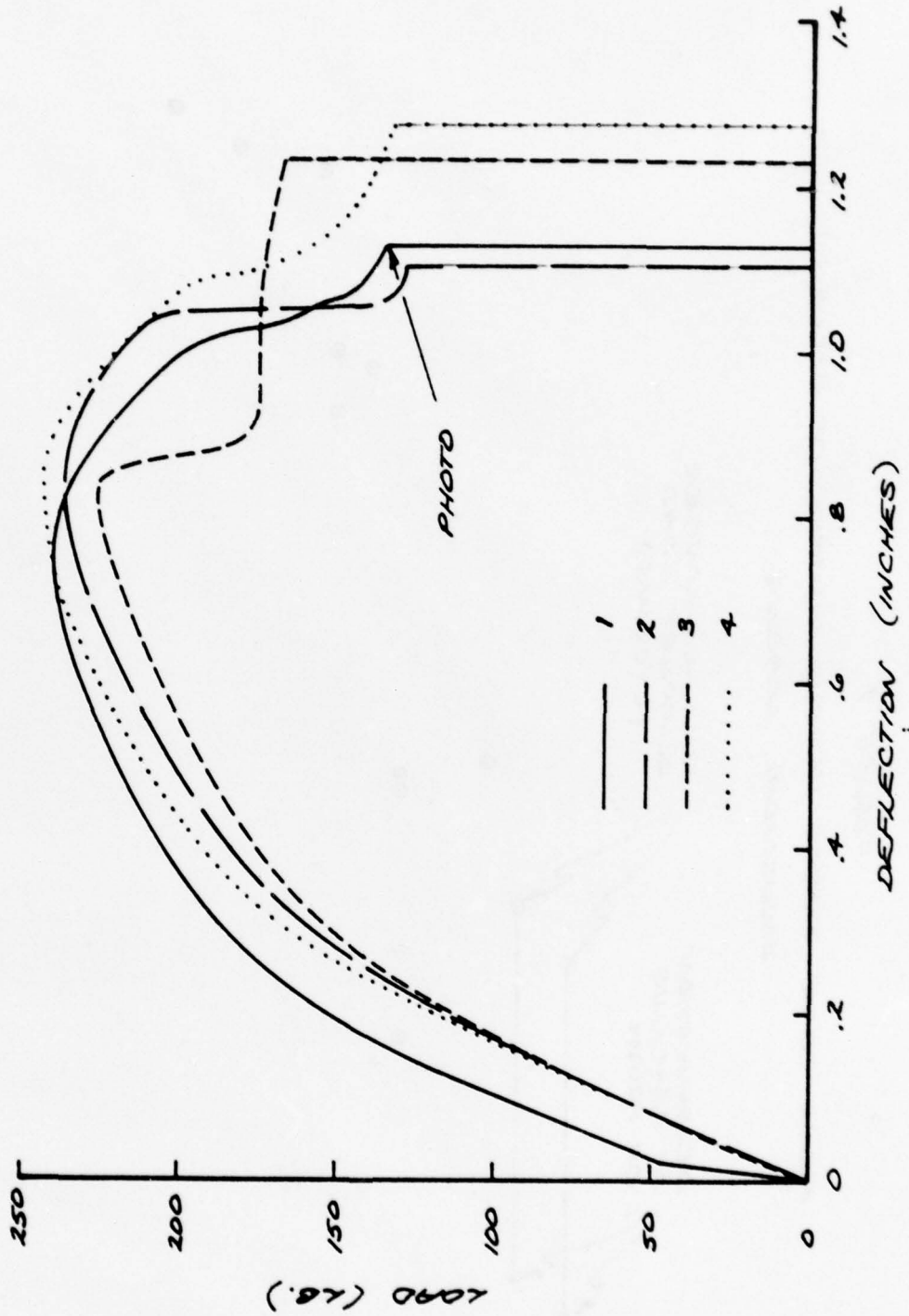

FIGURE 7
PEAK CORE SHEAR VERSUS NUMBER OF CYCLES
SINUSOIDAL LOADING

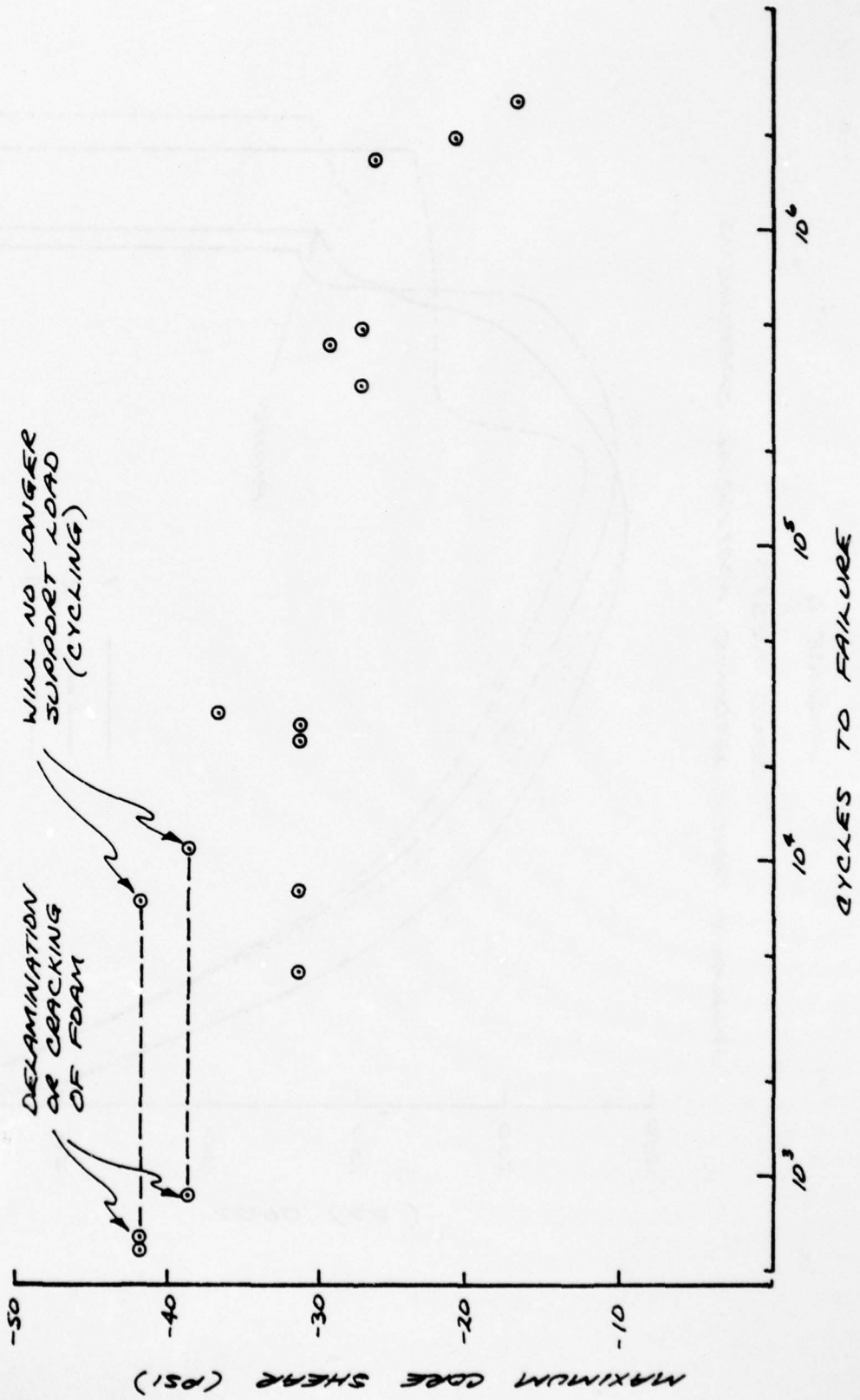
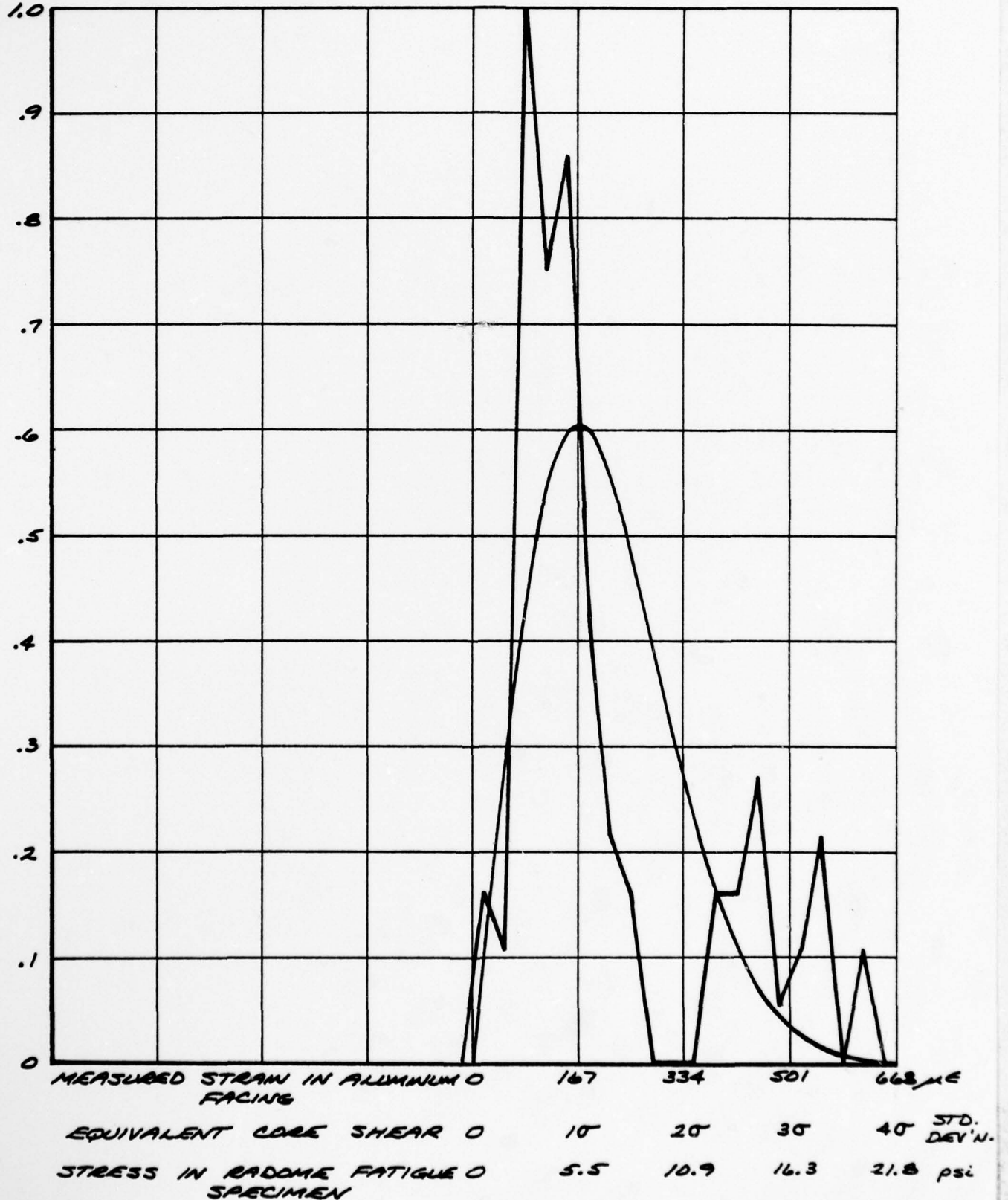

FIGURE 8
MEASURED STRAIN PEAK DISTRIBUTION HISTOGRAM,
ALUMINUM SKIN FOAM CORE PANEL,
SUBJECTED TO 30mm FIRING BLAST



CDRL A003
Code Ident 9243
M-24-6-678

APPENDIX I

DIMENSIONAL CONSTRAINTS

GENERAL DYNAMICS
Pomona Division

TECHNICAL MEMORANDUM

TM
24-6-838
MODEL
Naval Search Radome
CONTRACT
N66011-77-C-0139

DATE: 11 July 1978
TO: Mr. John Markall N.O.S.C. San Diego, CA.
FROM: Advanced Manufacturing Technology Dept. 24-6

SUBJECT:
Dimensional Constraints

REFERENCE:

DISTRIBUTION:
LIBRARY

PREPARED BY: W. L. MacTurk
W. L. MacTurk

PREPARED BY: _____

REVIEWED BY: _____

APPROVED BY: M. C. Abrams
M. C. Abrams

GENERAL DYNAMICS

Pomona Division

CDRL A002
Code Indent 9243
M-24-6-678

Dimensional Constraints of Naval Search Radome

No height dimension is referenced on drawing number 5188237 Radome - Search Radar.

Maximum height of radome would be the spherical radius $19.736 + .030'' = 19.766''$. Added to this would be the maximum thickness of the radome which would be the foam thickness $.190'' + .022''$ added to the facing thicknesses of $(.035 + .010) \times 2 = .090''$ giving a maximum height to the dome of $24.568''$. This excludes the polyurethane base sealant.

Since the height measurement of the radome is a good indication of its trueness when comparing diameter measurements, the outer mold assembly would reflect this condition, and this height measurement was within $.009''$ of $24.5''$ or $24.991''$.

Height measurement of the radome before base coating was $24.516''$ and reflects the trueness of the dome. Foam expansion during oven cure of the radome to stabilize the foam causes the small increase in height noted from the mold dimension. No dimension is given to the base sealant but the brush application is within $.025''$.

The drawing inner diameter of the radome at its base is given as $39.400'' +.040 - .000$ and the ID measured read $39.415''$. $1.25''$ above the base the diameter is given as $39.472'' +.076 - .088$.

Nominal thickness call out on the drawing is $.264''$. Over 5 readings the Quality Assurance group read $.261''$ average showing the excellent concentricity of the radome window and the close thickness dimensions held on the foam substrate and facings.

Appended is the Certificate of Compliance from Quality Assurance.

CERTIFICATE OF COMPLIANCE

DATE: 11 July 1978
 TO: W. L. MacTurk Dept. 24-6

IT IS HEREBY CERTIFIED THAT THE NAVAL HEMISPHERICAL RADOME HAS BEEN INSPECTED FOR HEIGHT, DIAMETER, AND THICKNESS.

HEIGHT: 24.543"
 DIAMETER: I.D. 39.415" SB 39.400 ⁺⁰⁴⁰/₋₀₀₀
 THICKNESS OVERALL: .261" Avg.

DESCRIPTION			
Dimensional Constraints of 40" Diameter Naval Radome			
PART NUMBER 5188237	REVISION -	PURCHASE ORDER NUMBER -	PACKING SHEET NUMBER -
OTHER DOCUMENTATION			
Contract N66001-77-C-0139 WJC			

BY: Samuel D. Wheeler 
(AUTHORIZED SIGNATURE)
 NAME: A. J. Havel
 TITLE: Chief Eng/Exp. Inspection
QUALITY CONTROL DEPARTMENT
 GENERAL DYNAMICS/POMONA

CDRL A003
Code Ident 9243
M-24-6-678

APPENDIX J

ENVIRONMENTAL TESTING AT TEMPERATURE EXTREMES

GENERAL DYNAMICS

Pomona Division

TECHNICAL MEMORANDUM

TM	24-6-774
MODEL	Naval Search Radome
CONTRACT	N66011-77-C-0139

DATE: 10 July 1978
TO: Mr. John Markall NOSC San Diego, CA.
FROM: Advanced Manufacturing Technology Dept. 24-6

SUBJECT: Sample Testing of Foam Core/Facings of Search Radome at Environmental Extremes

REFERENCE:

DISTRIBUTION:
LIBRARY

PREPARED BY: *Greg Paulitz*
Greg Paulitz

PREPARED BY: _____

REVIEWED BY: *W. L. MacTurk*
W. L. MacTurk

APPROVED BY: *M. C. Abrams*
M. C. Abrams

GENERAL DYNAMICS

Pomona Division

CDRL A002

Code Ident 9243

M-24-6-678

Sample Testing on the Foam Core/Facings Comprising the Basic Radome Structure

A test panel was prepared and test samples cut at random from the panel and the samples run according to The Test Procedure Plan (i) "Environmental Testing at Temperature Extremes". The CIWS Phalanx Specification requires storage temperatures of the radome to withstand temperature extremes of -40°F to $+160^{\circ}\text{F}$ and outlined below is the test procedure and test results achieved.

Sample Preparation

An aluminum box mold $24'' \times 24'' \times .264''$ with the necessary vent holes drilled through each side of the mold was constructed. Two thoroughly clean flat sheets of polyester/glass cloth, gel coated on one side and representing the facings of the radome were layed up. Overall thickness of the facings were $.035''$ and comprised a $.010''$ thick gel coat bonded to 4 oz glass cloth (2 layers) with polyester resin, again being identical in construction to the facings of the $40''$ diameter radome window. These facings were placed in the aluminum mold (gel coat side out); one facing placed in the bottom of the mold and the other attached to the lid of the box mold. Into the box mold the required amount of 2 lb/ft^3 free rise foam was poured after the A&B components of the foam had been thoroughly mixed, the lid then clamped to the box mold, and the foam allowed to expand and vent at the required hole locations. Since the restrained foam density of the $40''$ dia radome approximates 9 lbs/ft^3 (8.6 lbs/ft^3) the amount of foam poured into the mold was calculated to give this density.

Since $P = \frac{W}{V}$ where $P = \text{restrained density (lbs/ft}^3\text{)}$

$W = \text{weight of foam in mold (lbs)}$

and $V = \text{volume of mold (ft}^3\text{)}$

Allowing for 0.1 lbs sprue of the foam from the vent holes, 0.68 lbs of 2 lb/ft^3 foam was poured into the cavity. This gave a restrained density,

$$P = \frac{W}{V} = \frac{0.68-0.1}{0.065} = 8.92 \text{ lbs/ft}^3$$

GENERAL DYNAMICS

Pomona Division

CDRL A002
Code Ident 9243
M-24-6-678

The aluminum mold containing the panel was then heated in an oven for 4 hours at 160°F to stabilize the foam at this temperature extreme.

The panel on removal from the mold was then cut to afford 8 samples 6" long by 2" wide, each sample being cut at random from the 24" square panel. Figure 1 shows the test samples in the thermal chamber.

Since the base of the 40" diameter radome is sealed with a polyurethane elastomer to prevent moisture absorption and damage to the foam interface, 4 samples had their edges coated with this elastomer, and the other 4 samples left uncoated to determine if during temperature cycling, moisture absorption into the foam would affect the foam/facing bond.

Test Procedure

A CO₂ bottle was connected to a calibrated thermal chamber, the chamber containing an automatic sensor and solenoid control to maintain the low temperature extreme required (-40°F). The chamber was also equipped with high temperature controls when manually set to the temperature desired (+160°F). Also attached to the chamber with an iron/constantan thermocouple was a precision digital thermometer ($\pm 2^\circ\text{F}$, -60°F to + 500°F).

Temperature cycling was recorded on a calibrated thermal graph recorder also attached to the chamber. Testing would involve temperature cycling the 8 foam core/facing samples from -40°F to +160°F for 10 cycles in the following manner to the time durations called out in Mil-Std 202D, Table 107-1.

-40°F for 30 minutes	} 1 Cycle
Room Temp for 5 minutes max.	
+160°F for 30 minutes	

Time to cycle between -40°F and +160°F had a time duration of less than 5 minutes and conversely time duration to cycle between +160°F to -40°F was less than 5 minutes. Figure 2 shows the test set up and Figure 3 a graph of the thermal cycling.

GENERAL DYNAMICS

Pomona Division

CDRL A002
Code Ident 9243
M-24-6-678

The test samples were then examined for flatness, facing integrity, and foam/facing adhesion before being placed in the chamber and the test begun. The 10 cycles were completed in one day, the test commencing at 8:00 am and finishing that night at approximately 8:00 pm.

Test Results

Visual examination of the 8 test samples on removal from the test chamber showed no detrimental effects from the harsh extreme temperature cycling. Test samples had retained their flatness indicating again the uniform non-stress condition of the foam core/facing adhesion, and its ability to withstand thermal expansion and contraction at severe temperature gradients. Also since no bonding adhesives or films are used in the facing/foam adhesion and no elevated temperatures required to bond the facings to the foam core, no stress conditions are induced which could cause warping of the test sample or radome at temperature extremes. Microscopic examination of the test samples indicated no fissuring of the gel coat and no crazing of the resin pigment. No delamination of the facings from the foam could be detected or facing bubbles, due to air/gas expansion from the foam substrate.

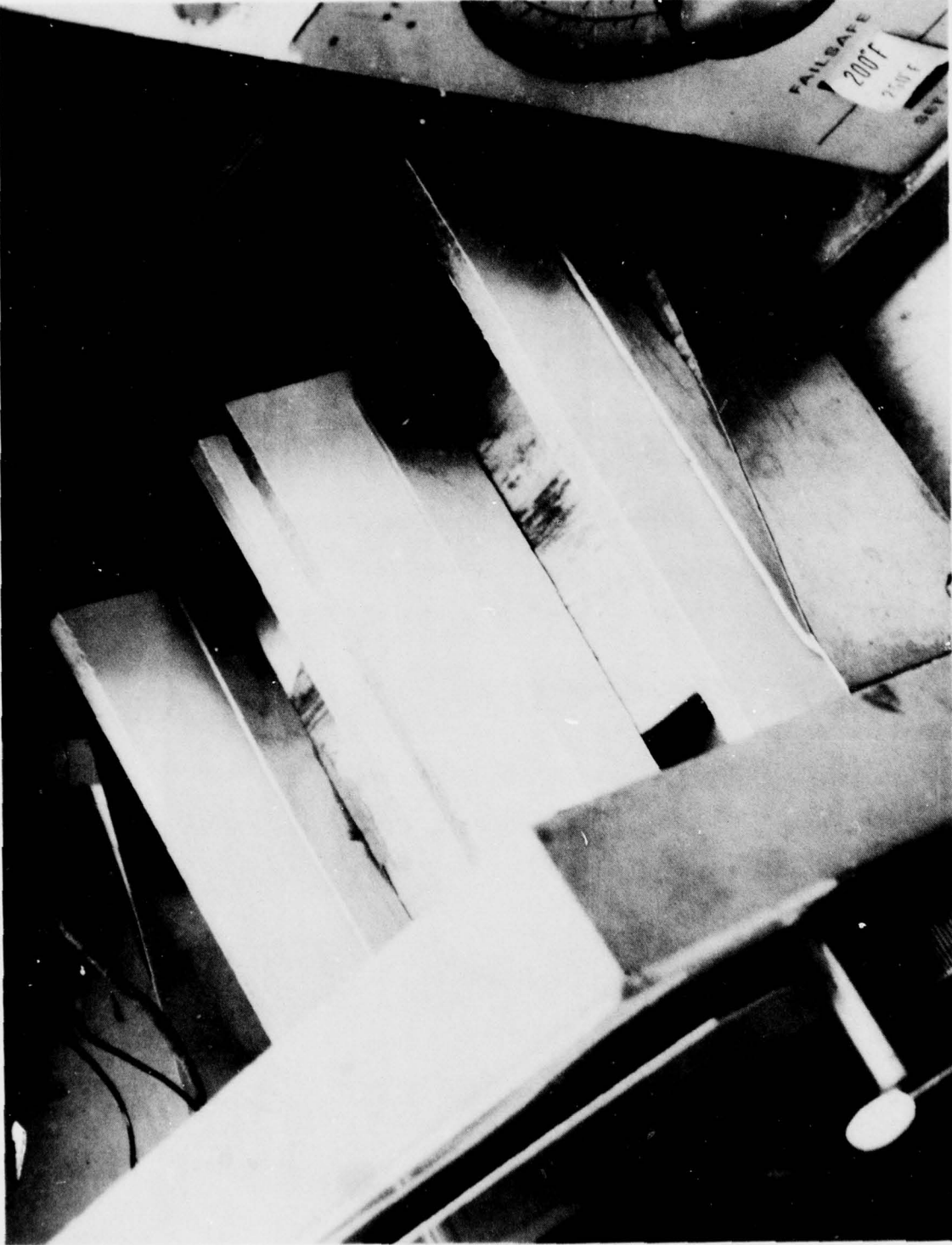

ENVIRONMENTAL TESTING AT
TEMPERATURE EXTREMES
FOAM/FIBERGLASS SAMPLES

FIGURE 1

P.O. 5-78-81527

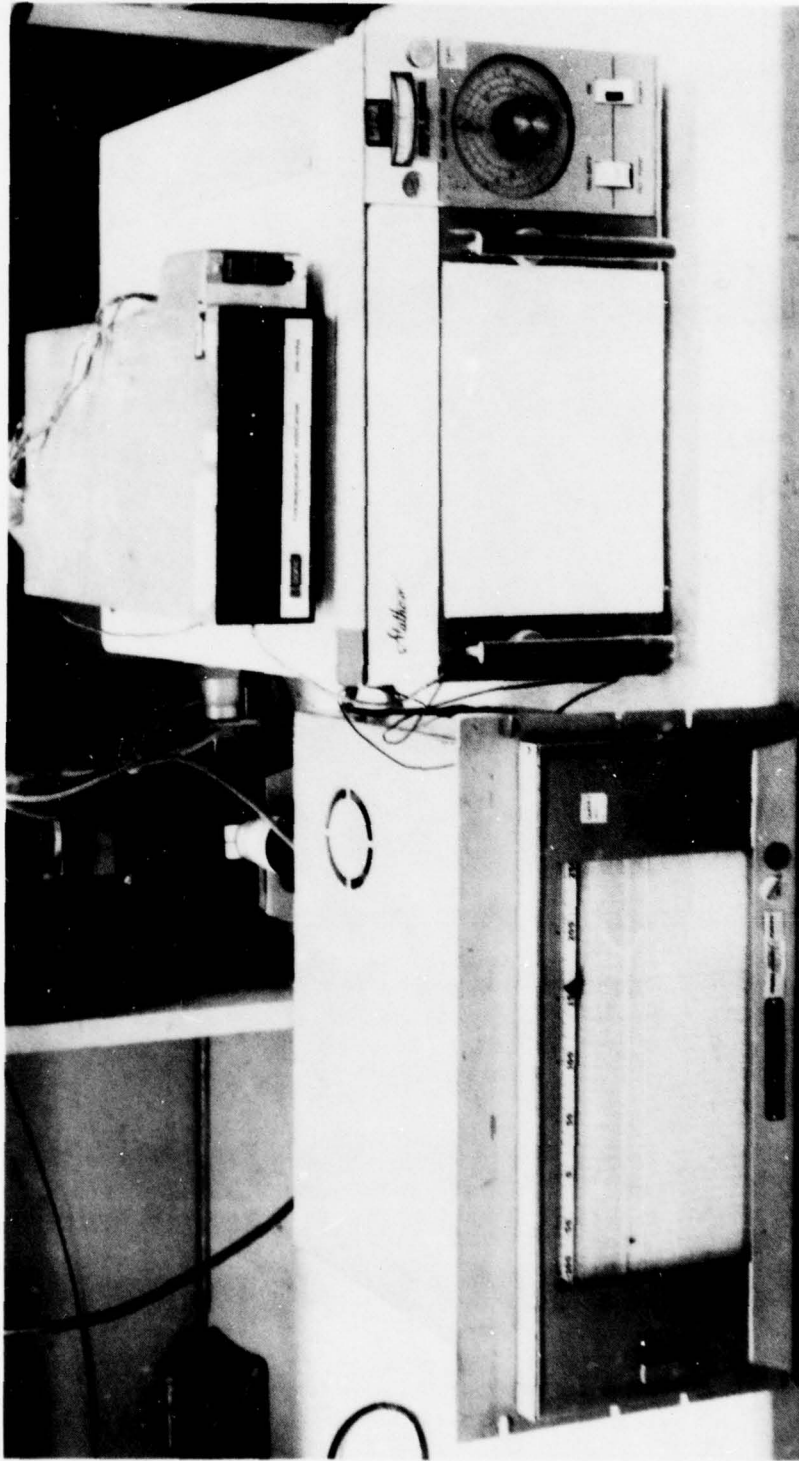

FIGURE 2

ENVIRONMENTAL TESTING AT
TEMPERATURE EXTREMES
TEST SETUP

P.O. 5-78-8152B

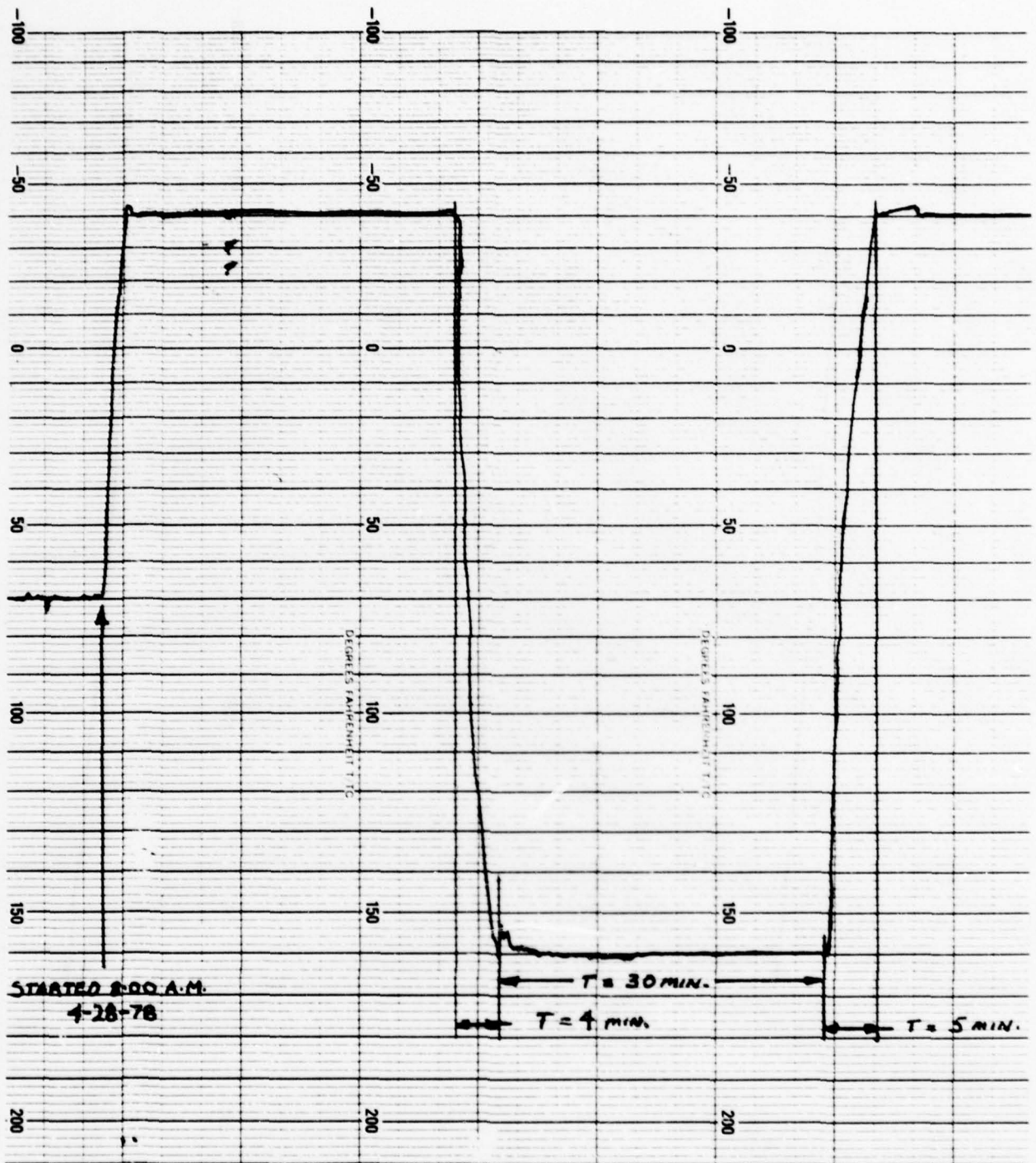

Figure 3. (Sheet 1 of 8)

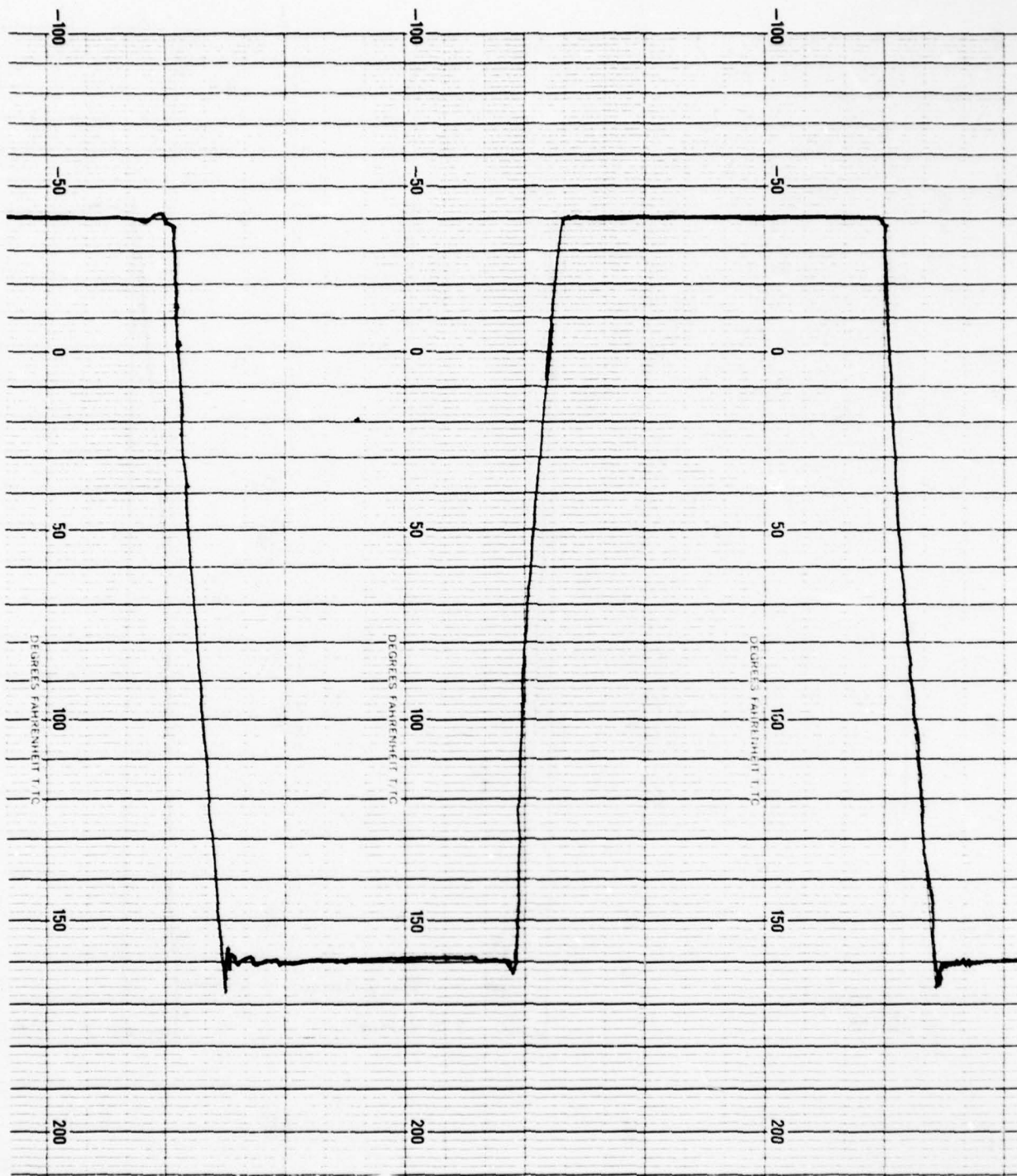

Figure 3. (Sheet 2 of 8)

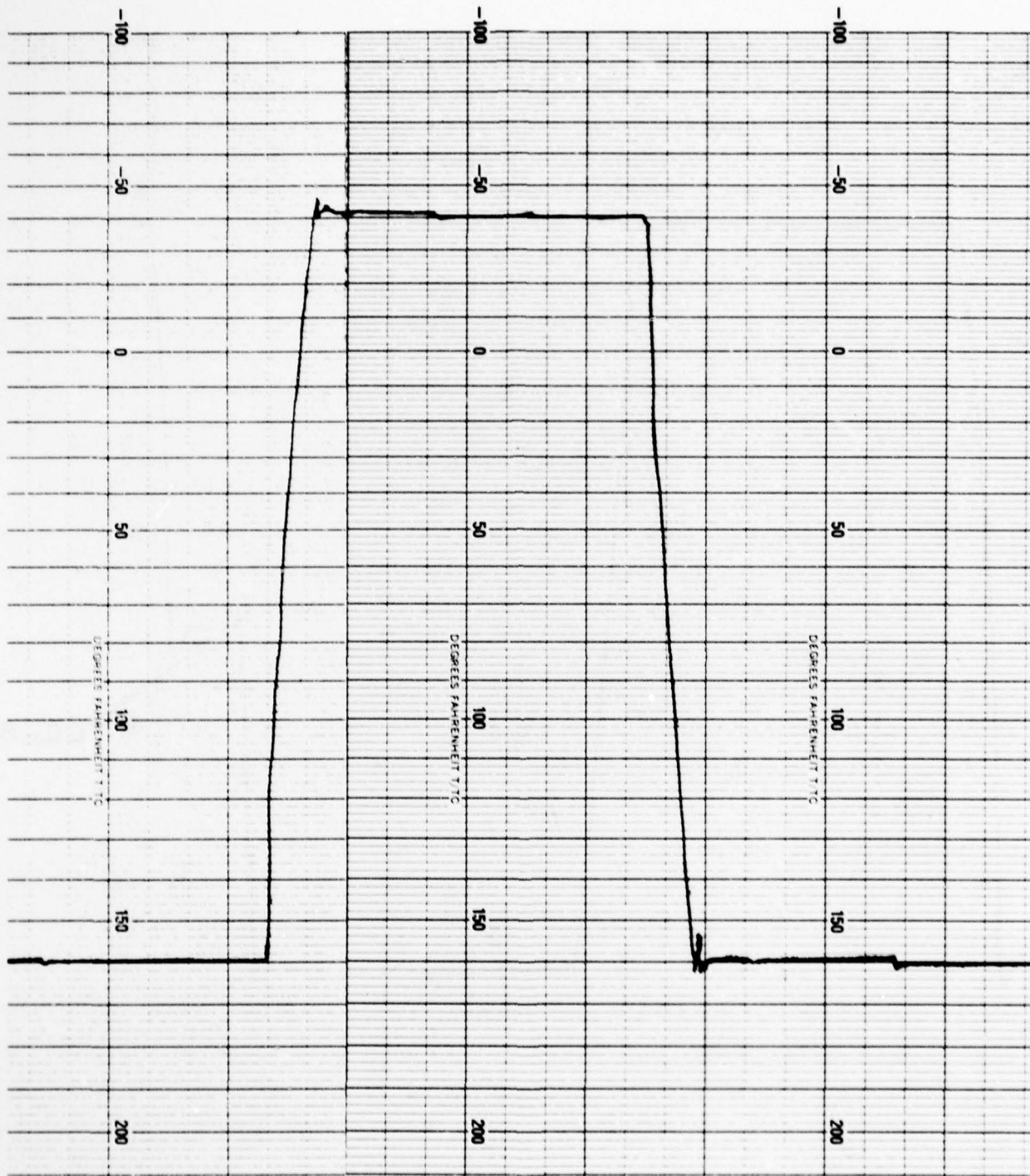

Figure 3. (Sheet 3 of 8)

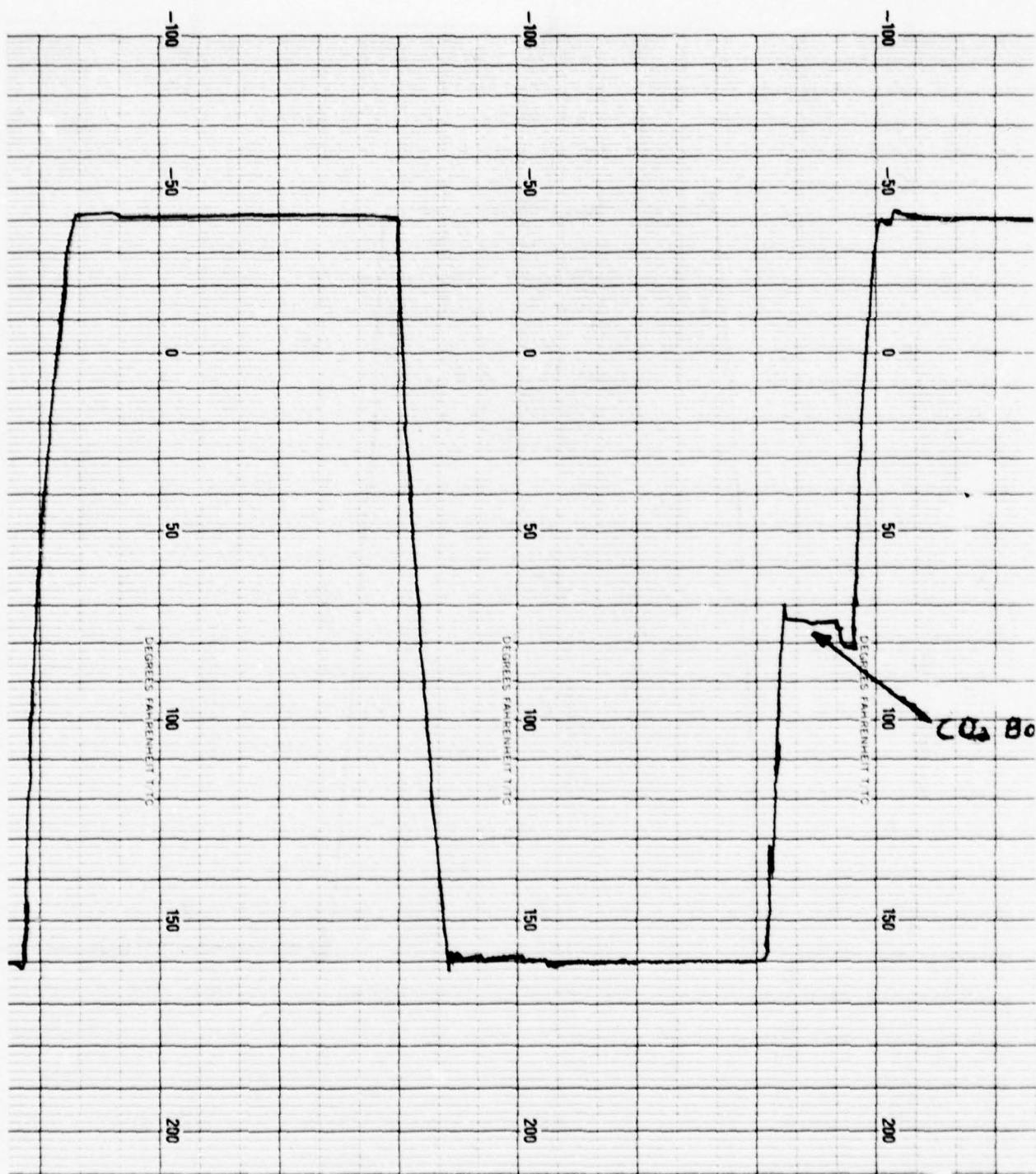

Figure 3. (Sheet 4 of 8)

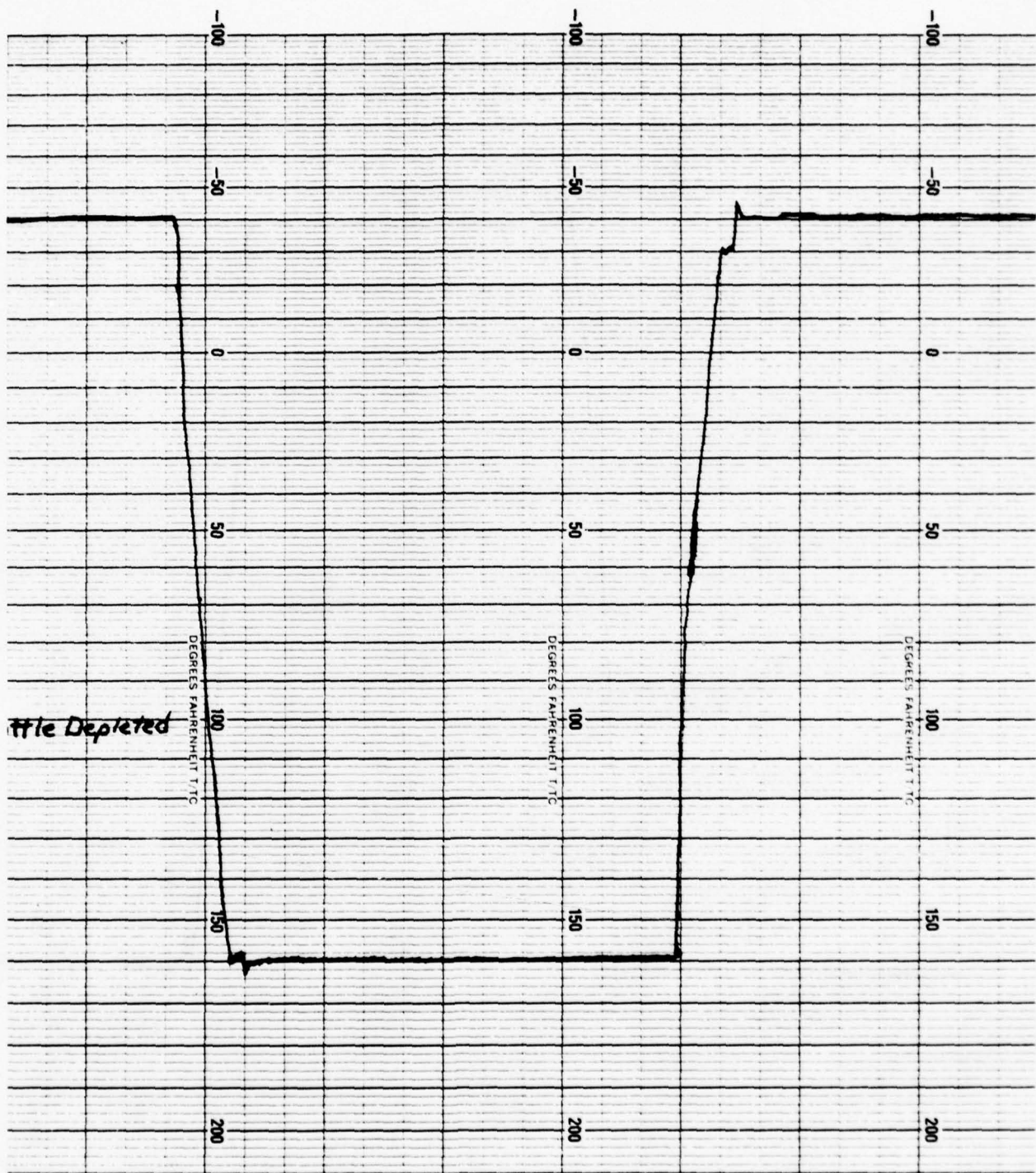

Figure 3. (Sheet 5 of 8)

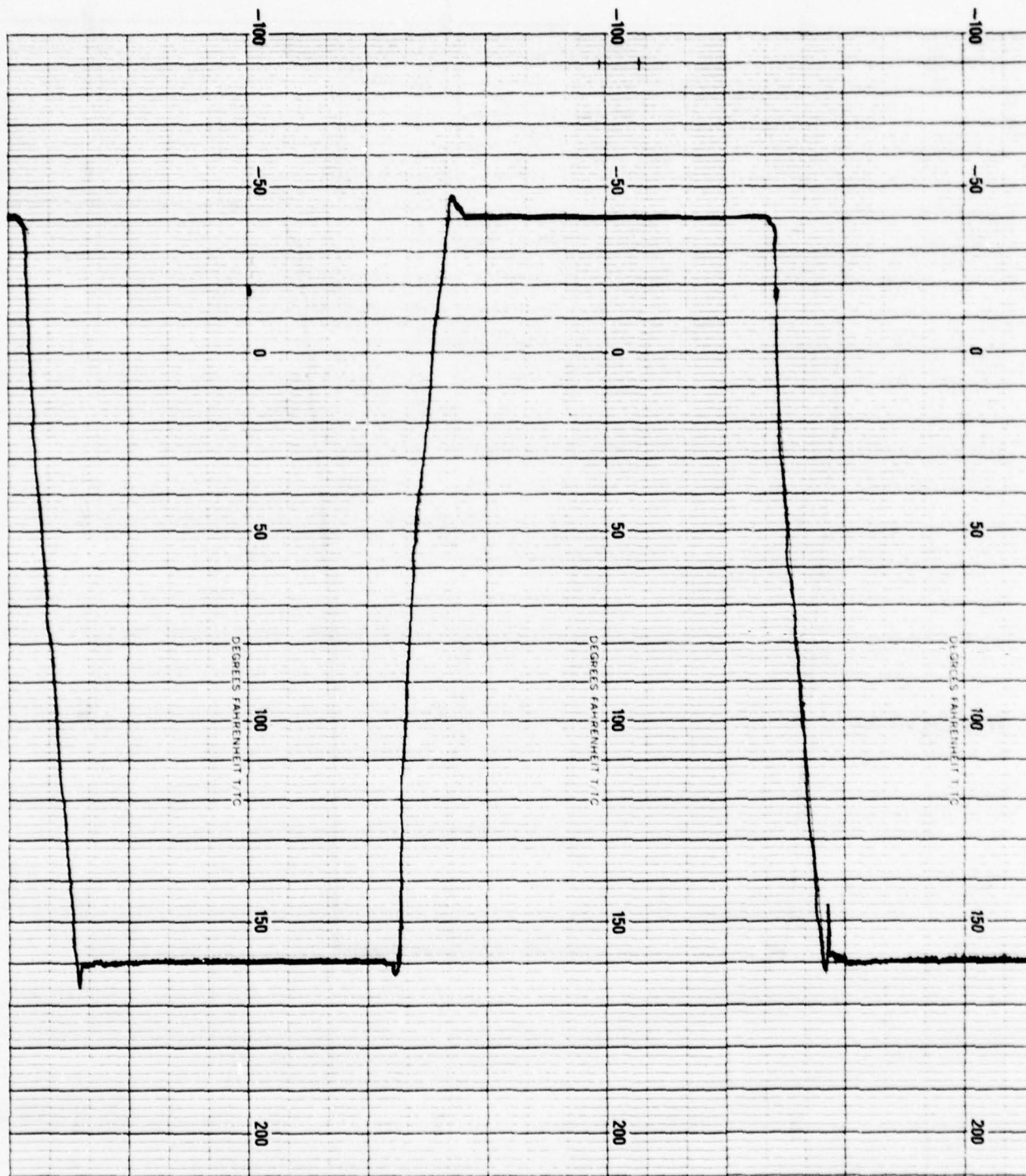

Figure 3. (Sheet 6 of 8)

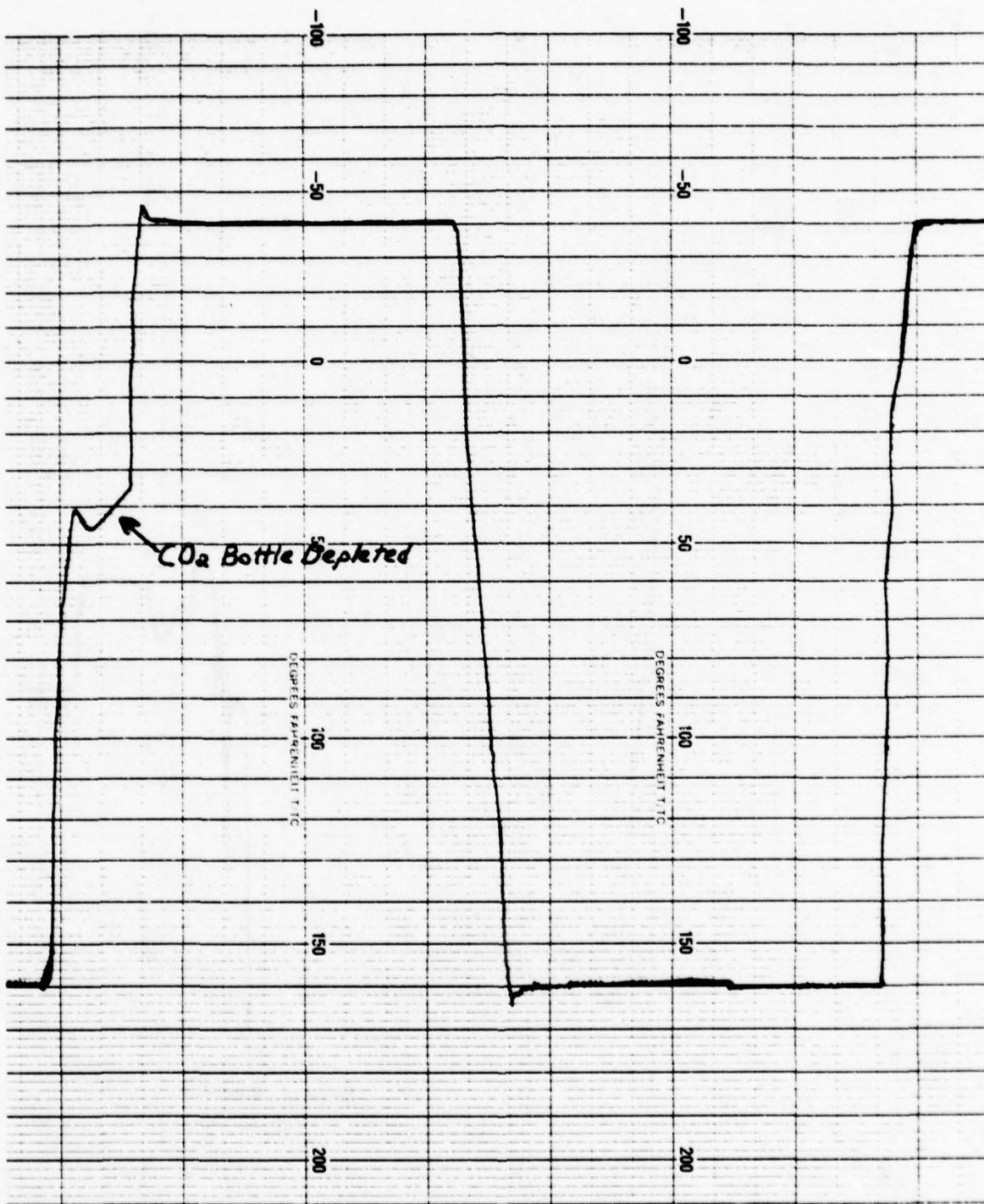

Figure 3. (Sheet 7 of 8)

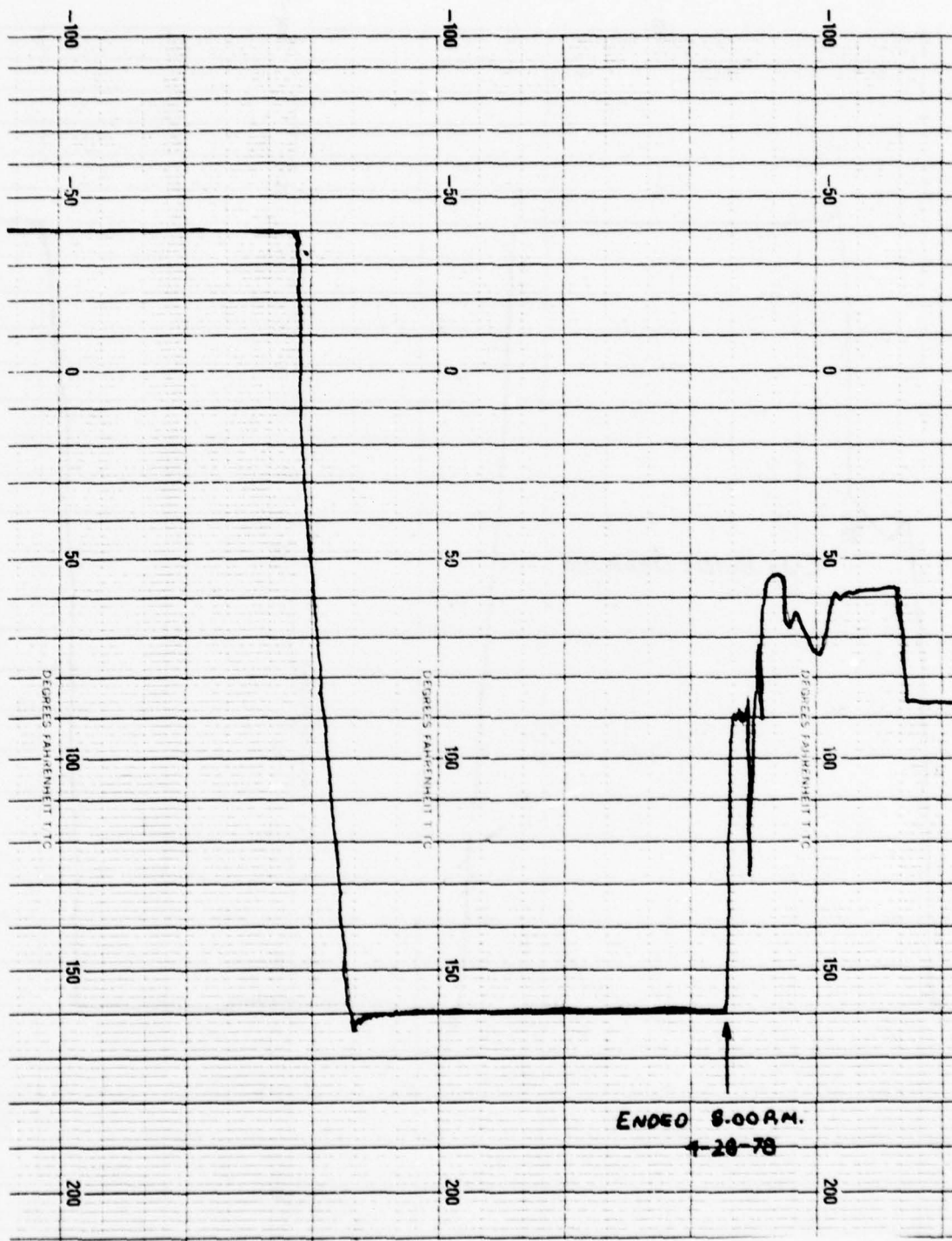

Figure 3. (Sheet 8 of 8)

CDRL A003
Code Ident 9243
M-24-6-678

APPENDIX K

FUNGUS RESISTANCE OF FOAM SUBSTRATE AND FACINGS

GENERAL DYNAMICS
Pomona Division

TECHNICAL MEMORANDUM

TM
24-6-775
MODEL
Naval Search Radome
CONTRACT
N66011-77-C-0139

DATE: 10 July 1978
TO: Mr. John Markall N.O.S.C. San Diego, CA.
FROM: Advanced Manufacturing Technology Dept. 24-6

SUBJECT:
Fungus Resistance of Foam Substrate and Facings of 40" Naval Search Radome

REFERENCE:

DISTRIBUTION:
LIBRARY

PREPARED BY:

W. L. MacTurk
W. L. MacTurk

PREPARED BY:

REVIEWED BY:

APPROVED BY:

M. C. Abrams
M. C. Abrams

GENERAL DYNAMICS

Pomona Division

CDRL A002

Code Ident 9243

M-24-6-678

Submitted with this appendix showing the non-nutrient characteristics of the search radome to fungus growth is Mil-Std 454 E Group I which characterizes polyester glass fiber laminates as fungus inert, the basic structure of the naval search radome. Also attached are the vendor specifications as to resin and glass used, the foam substrate properties, and the polyurethane elastomer PR1660L used as the radome base sealant, with reference to the Mil Standards where applicable. The Phalanx CIWS Design Instruction DI-444-A-002A submitted under Appendix N deals in paragraph 2.10 Fungus, that the CIWS shall use fungi resistant materials in accordance with Mil-Std-454, tested to Mil-Std-810. The Naval Search Radome meets these requirements.

REQUIREMENT 4

FUNGUS-INERT MATERIALS

1. Purpose. This requirement identifies those materials which are acceptable nonnutrients of fungus and establishes the conditions or treatments under which fungus nutrients are acceptable.

* 2. Documents applicable to Requirement 4:

ASTM G21-70 Determining Resistance of Synthetic Polymeric Materials to Fungi
Code of Federal Regulations, Title 29, Chapter XVII, Part 1910

3. Materials

a. For new designs, only inherently fungus-inert materials shall be used except that other materials may be used in hermetically sealed assemblies or other specifically approved items.

b. For repro cured equipment, if it is necessary to use nutrient materials in other than the above approved applications, they shall be treated by a method that will render the exposed surface fungus-resistant so that they will pass the test of 3.2. When materials are compounded with a permanently effective fungicide in order to pass the fungus test, there shall be no loss of the original electronic or physical properties required by the basic materials specification.

3.1 Fungus susceptibility. Group I in table 4-I lists those materials which are considered not to be nutrient to fungi in all modified states and grades. Group II lists materials which are not fungus-inert in all grades and therefore the fungus resistance of the materials selected shall be confirmed by testing in accordance with 3.2.

3.2 Fungus testing. Group II and treated materials selected for other than approved applications (see para 3) shall pass the fungus test specified in ASTM G21. There shall be no visible growth of fungus after 28 days. Certification by a qualified laboratory or by the material producer, based upon test data on record that the selected material passed the above test, will be sufficient evidence of acceptability.

3.2.1 Nonplastic materials. All nonplastic materials to be tested for fungus-susceptibility in accordance with 3.2, such as paint, ink, coatings, adhesives, lubricants, rubber, viscous damping fluids, silicone grease, etc, shall be prepared in the form of 2-inch squares or circles no more than 1/16-inch thick for testing. Liquid or paste materials shall be prepared by impregnating to saturation a sterile sample of glass fabric.

* 3.3 Carcinogens. Certain chemicals have been identified in the Occupational Safety and Health Act (OSHA) as cancer-producing substances (carcinogens). Before using any materials which might contain these chemicals, they should be evaluated in accordance with the Code of Federal Regulations, Title 29, Chapter XVII, Part 1910. Consideration of the toxicity of a substance shall be given prior to material selection.

Supersedes
REQUIREMENT 4
1 August 1975

REQUIREMENT 4
26 September 1977

Table 4-I. Fungi Susceptibility of Materials

GROUP I

(Fungus-inert in all modified states and grades)

Acrylics	1/ Polyamide
Acrylonitrile-styrene	Polycarbonate
Acrylonitrile-vinyl-chloride copolymer	Polyester-glass fiber laminates
Asbestos	Polyethylene, high density (above 0.940)
Ceramics	Polyethylene terephthalate
Chlorinated polyether	Polyimide
Fluorinated ethylenepropylene copolymer (FEP)	Polymonochlorotrifluoroethylene
Glass	Polypropylene
Metals	Polystyrene
Mica	Polysulfone
Plastic laminates:	Polytetrafluoroethylene
Silicone-glass fiber	Polyvinylidene chloride
Phenolic-nylon fiber	Silicone resin
Diallyl phthalate	Siloxane-polyolefin polymer
Polyacrylonitrile	Siloxane-polystyrene

GROUP II

(Not fungus-resistant in all grades;
fungus-resistance shall be established by test)

ABS (acrylonitrile-butadiene-styrene)	Polyethylene, low and medium density (0.940 and below)
Acetal resins	Polymethyl methacrylate
Cellulose acetate	Polyurethane (the ester types are particularly susceptible)
Cellulose acetate butyrate	Polyricinoleates
Epoxy-glass fiber laminates	Polyvinyl chloride
Epoxy-resin	Polyvinyl chloride-acetate
Lubricants	Polyvinyl fluoride
Melamine-formaldehyde	Rubbers, natural and synthetic
Organic polysulphides	Urea-formaldehyde
Phenol-formaldehyde	
Polydichlorostyrene	

1/ Literature shows that under certain conditions polyamides may be attacked by selective micro-organisms. However, for military applications they are considered group I.



EXPANDED RUBBER & PLASTICS CORP.

14000 S. WESTERN AVENUE, GARDENA, CALIFORNIA 90249
(213) 321-4260 324-6692

FUNGUS RESISTANCE OF POLYURETHANE FOAMS

The fungus resistance of polyurethane foams has been investigated by Bayer, (1) Tropic-proofing tests (protection against deterioration due to tropical climates) were carried out on two inch cubes of rigid foam. Spore suspensions of various fungi (species of which were often found on equipment returned from the tropics in a moldy condition) were prepared in Ringer's solution (physiol. sol. containing NaCl, KCl, CaCl₂, NaHCO₃, NaH₂PO₄, dextrose, and H₂O). These were mixed and sprayed on the surface of the foam samples. The samples were then incubated at 30°C and 100% relative humidity and were examined weekly for mold growth.

Uninfected control cubes of foam were included in these tests as were pieces of cork which were sprayed with the fungi solution. After one week of incubation, fungal growth had started on all the cork samples but on none of the rigid samples.

After four weeks of incubation, fungus growth had rapidly progressed on the cork samples but still was absent from the rigid foam specimens. Even after twelve weeks of incubation, the rigid foam samples were devoid of mold growth.

- (1) Reference Polyurethane Chemical and technical, Part II, Page 268

Products Research & Chemical Corporation

Western Sales & Manufacturing
5454 San Fernando Road, P.O. Box 1800
Glendale, California 91209
(213) 240-2060 Telex 67-7067



April 4, 1978

General Dynamics
Post Office Box 2507
Pomona, California 91766

Attention: Mr. Greg Paulitz, Mail Zone 4-26

Gentlemen:

Pursuant to your request concerning the fungus resistance of PR-1660-L, we are enclosing a technical data sheet on PR-1660 which shows that PR-1660 is non-nutrient per MIL-STD-810B.

We have never tested PR-1660-L for fungus resistance, however, since it is basically a solvent let down of PR-1660 we would also expect it to be non-nutrient to the organism described in MIL-STD-810B.

We hope that the above information will be of some assistance. If we can be of further service, please let Mr. Jack Dyer, at the above address, or us know.

Very truly yours,

PRODUCTS RESEARCH & CHEMICAL CORPORATION

Roger Cournoyer, Assistant Manager
Engineering Service Department

RC:cp
Enclosure
cc: Jack Dyer

K-6

Recommendations for the use of our products are based on tests we believe to be reliable. Manufacturer and seller are not responsible for results where the product is used under conditions beyond our control. Under no circumstances will Products Research & Chemical Corporation be liable for consequential damages or damages to anyone in excess of the purchase price of the products.

Corporate Headquarters
5430 San Fernando Road, P.O. Box 1800
Glendale, California 91209
(213) 240-2060 Telex 67-4208

Eastern Sales & Manufacturing
410 Jersey Avenue
Gloucester City, New Jersey 08030
(609) 456-5700 Telex 83-4445

Research Laboratories
2820 Empire Avenue
Burbank, California 91504
(213) 240-2060 Telex 67-7067

Cable Address
PRORECO



protective coatings
caulking compounds
sealants • adhesives

LABORATORY PRODUCT REPORT
 ON
 PR-1660

DESCRIPTION

This material is a two-part, 100% solids, polyether-base, polyurethane elastomer designed for potting, molding, adhesive, or sealing applications where superior physical properties and high Shore A hardness are required. PR-1660 contains no MOCA* or MOCA derivatives.

APPLICATION PROPERTIES (Typical)

		<u>Amber</u>	<u>Black</u>
Color	Part A Part B Part C	Tan solid Clear liquid -	Tan solid Clear liquid Black paste
Mixing Ratio By weight		Part A:Part B 11.5:100	Part A:Part B:Part C 11.5 : 100 : 0.56
Viscosity (Mixed) At 120°F - 140°F			10 - 80 poise
Application Life To 2500 poise At 120°F At 140°F			30 min. 30 min.
Tack Free Time At 75°F			3 hrs.
Mold Release Time			2 hrs. @ 180°F or 3 hrs. @ 160°F or 8 hrs. @ 75°F
Cure Time To 90 Shore A			3 hrs. @ 212°F or 12 hrs. @ 180°F or 16 hrs. @ 160°F or 14 days @ 75°F**

*Registered tradename of DuPont for 4,4'-methylene-bis-(2-chloroaniline).

**Physical properties of 75°F cured material are slightly less than those obtained with a heat cure.

SUPERSEDES
 March 1974

PRODUCTS RESEARCH & CHEMICAL CORPORATION
 CHEMICAL PRODUCTS DIVISION

2919 EMPIRE AVENUE
 BURBANK, CALIFORNIA 91501
 AREA CODE 213 849-3992

K-7

410-416 JERSEY AVENUE
 GLOUCESTER CITY, NEW JERSEY 08030
 AREA CODE 609 456-5700

DATE ISSUED
 August 1976

PR-1660

PHYSICAL PROPERTIES (Typical)

Color	Light amber
Specific Gravity	1.03
Hardness, Shore A	90
Tensile Strength (ASTM D 412)	4000 psi
Ultimate Elongation (ASTM D 412)	400%
Tear Strength (ASTM D 624, Die C)	400 lbs./in.
Abrasion Resistance (1 Kg/1000 rev.) Taber Abraser, CS-17 Wheel	3 mg. loss
Fungus Resistance (MIL-STD-810B)	Non-nutrient

ELECTRICAL PROPERTIES (Typical)

Dielectric Strength Specimen thickness 125 mils	400 volts/mil
Insulation Resistance At 75° F	3×10^7 megohms
Volume Resistivity At 75° F	8×10^{13} ohm-cm
At 150° F	2×10^{12} ohm-cm
At 250° F	6×10^{10} ohm-cm
Surface Resistivity At 75° F	1×10^{15} ohms
At 150° F	3×10^{14} ohms
At 250° F	1×10^{13} ohms
Dielectric Constant 1 KHz @ 75° F	5.3
1 MHz @ 75° F	4.1
Power Factor 1 KHz @ 75° F	0.04
1 MHz @ 75° F	0.06

NOTE: The above application and electrical property values are typical for the material, but not intended for use in specifications or for acceptance inspection criteria because of variations in testing methods, conditions, and configurations.

MIXING INSTRUCTIONS

PR-1660 is supplied in premeasured kits and should be handled as follows:

A. Amber

1. Heat Part B to 120° F.
2. Heat Part A to 200° F until material becomes a clear, dark amber liquid.
3. Add Part A to Part B and mix immediately. Transfer mixed material to metal container of approximately 2 to 3 times the volume of the mixed material and degas under vacuum. To facilitate degassing, Part B may be vacuum degassed at 120° F prior to mixing with Part A.

B. Black

1. Heat Part B to 120° F.
2. Add 0.5% of Part C by weight (or 0.56 parts of Part C) of total combined contents of Part A and Part B to Part B and mix until homogeneous.
3. Heat Part A to 200° F until material becomes a clear, dark amber liquid.
4. Add Part A and mix immediately. Transfer mixed material to a metal container of approximately 2 to 3 times the volume of the mixed material and degas under vacuum. To facilitate degassing, Part B may be vacuum degassed at 120° F prior to mixing with Part A.

CURE

PR-1660 may be subjected to elevated cure temperatures immediately after pouring or injecting. To obtain maximum physical properties, PR-1660 must be cured as follows:

- 3 hrs. @ 212° F or
- 12 hrs. @ 180° F or
- 16 hrs. @ 160° F or
- 14 days @ 75° F.

Physical properties of 75° F cured material are slightly less than those obtained with a heat cure.

STORAGE LIFE

Storage life of PR-1660 is approximately one year when stored below 80° F in the original, unopened containers.

PACKAGING INFORMATION

PR-1660 is supplied in 32 fl. oz., 128 fl. oz., and 5-gallon units.

HEALTH PRECAUTION

PR-1660 contains no volatile solvents, but should be used with adequate ventilation.

The uncured components of PR-1660 will produce irritation following contact with skin. When handling Parts A and B, avoid all contact with the body, especially contact with

PR-1660

open breaks in the skin, or ingestion. Always wash hands thoroughly with soap and water before eating or smoking. Obtain medical attention in case of extreme exposure or ingestion.

DC:cm

"PRC" is a trademark of Products Research & Chemical Corporation, registered with the U. S. Patent Office

All recommendations, statements, and technical data contained herein are based on tests we believe to be reliable and correct, but accuracy and completeness of said tests are not guaranteed and are not to be construed as a warranty, either express or implied. User shall rely on his own information and tests to determine suitability of the product for the intended use and user assumes all risk and liability resulting from his use of the product. Seller's and manufacturer's sole responsibility shall be to replace that portion of the product of this manufacturer which proves to be defective. Neither seller nor manufacturer shall be liable to the buyer or any third person for any injury, loss, or damage directly or indirectly resulting from use of, or inability to use, the product. Recommendations or statements other than those contained in a written agreement signed by an officer of the manufacturer shall not be binding upon the manufacturer or seller.



EXPANDED RUBBER & PLASTICS CORP.

14000 S. WESTERN AVENUE, GARDENA, CALIFORNIA 90249

(213) 321-4260 324-6692

STATHANE 6500 SERIES

GENERAL: Expanded Rubber and Plastics Stathane 6500 Series material was specifically developed to provide foam system with low viscosities, low free isocyanate content to minimize toxicity, low exotherm, exceptional overall physical performance characteristics, good moldability and excellent thermo conductivity properties. In addition, the foam produced from these systems can be cured at room temperature, and reactivity characteristics of the systems are such, that the user has ample time for processing of the materials with conventional mixing equipment.

SPECIFICATIONS: The 2 lbs/ft density material, designated as Stathane 6502, meets Bureau of Ships Specification Mil-P-21929.

TYPE OF BASE MATERIALS: Freon expanded polyether-polmeric isocyanate rigid polyurethanes.

MIXING AND MOLDING INSTRUCTIONS: Component temperatures should be held at 65°- 75°F during mixing. Higher temperatures will cause loss of the "blowing agent" and, thus, cause an increase in density. Average mixing time is 30 - 50 seconds for all standard systems, but will vary with component temperatures, mixer speed and environmental conditions. Recommended mold temperature is 90°- 110°F for metal molds, try to keep above 75°F for most applications. Our Sales or Technical Departments will assist customers in the selection of proper molds, release agents etc., for special applications.

CURE: Foamed material will be sufficiently cured after 1 - 2 hours at ambient temperatures to be handled, however, optimum physical properties of the foam can be obtained only after a minimum of 24 hours cure at aforementioned conditions. This process can be accelerated by curing the material for one hour per inch of cross sectional area at elevated temperatures between 130°- 160°F.

If final service temperature is above 180°F, parts should be cured 15°F above anticipated maximum operating temperature. If material is cured at elevated temperature, parts must be cured in the mold and should not be demolded prior to cooling down the part and mold to ambient temperatures. Recommended Max. use temperature is 225°F.

CAUTION: Part 1 of the systems contains isocyanate, thus use in well ventilated area.

SUGGESTED APPLICATIONS:

1. General Purpose where fire retardancy required.
2. Flotation
3. Refrigeration Insulation
4. Aircraft structural reinforcement
5. Field Applications
6. Trailer bodies
7. Void filling
8. Sandwich panel construction
9. Molding of specialty items
10. Artistic designs

PHYSICAL PROPERTIES
STATHANE 6500 SERIES

Note: All results represent averages of various batches of materials run on free rise core density samples. Samples were obtained from 14" x 14" x 6" blocks prepared in the laboratory.

System Code	6502	6504	6506	6508	6510	6512	6520
Nominal Density, Lbs/Ft ³	2	4	6	8	10	12	20
Compressive Strength, PSI @ Yield point II to foam rise @ 77°F	30	80	140	240	315	480	900
Tensile Strength, PSI, Ult. @ 77°F, II to foam rise	40	110	155	210	250	310	570
Tensile Modulus, PSI II to foam rise @ 77°F, x 10 ³	0.5	0.8	1.3	2.2	3.3	5.0	16.0
Shear Strength, PSI II to foam rise @ 77°F	26	58	74	120	160	215	560
Dielectric Constant at 9.373 KMC	1.04	1.08	1.12	1.18	1.22	1.26	1.38
Loss Tangent at 9.373 KMC, x 10 ⁻³	0.5	0.5	0.6	0.6	0.8	0.9	2.4
K - Factor - BTU/HR/FT ² /IN/°F	0.17	0.18	0.19	0.19	0.21	0.23	0.25
Flammability Per ASTM 1692-67T	SE	SE	SE	SE	SE	SE	SE
Volume change after Humid aging per Mil- P-21929	±6%	(2 lbs/ft density only)					
Change in Compr. Strength per Mil-P-21929	-5%	(2 lbs/ft density only)					

The information contained in this literature is to the best of our knowledge, true and accurate. Since conditions of use are beyond our control, all recommendations and suggestions are made without guarantee. Expanded Rubber and Plastics Corporation disclaims any liability for the use of these suggestions or data. Nothing contained herein is a recommendation to use any product in conflict with the third parties patent rights. All products should be used only under well ventilated conditions.

KOPPERS

Polyester Resins

TECHNICAL DATA
SHEET

APRIL, 1976

KOPPERS POLYESTER RESIN 1063-5 AND 1073-5*

LOW REACTIVITY, LOW VISCOSITY POLYESTER RESIN

THIXOTROPIC OPEN MOLD RESIN

PHYSICAL CHARACTERISTICS

Monomer	Styrene
Viscosity, 77°F., poises	4.0 - 6.0
Specific Gravity, 77°F.	1.09 - 1.11
Thixotropic Index, 77°F., minimum	2.5

PERFORMANCE CHARACTERISTICS

FIBER WETTING	EXCELLENT
SAGGING AND DRAINING	MINIMUM
FABRICATING METHOD	ALL ROOM TEMPERATURE METHODS

APPLICATION

Koppers Polyester Resin 1063-5 is a low reactivity, low exotherm thixotropic polyester resin designed for good wet out and long trim times in open mold operations. This resin is fully promoted and only requires the addition of methyl ethyl ketone peroxide for cure. The outstanding characteristic of this resin is its low exotherm buildup during cure. This resin is applicable in most sprayup operations and is particularly suitable for relatively thick sections. Trim times are longer with this resin than with most fully promoted open mold resins. Resistance to sagging and draining on vertical surfaces is excellent.

*Koppers Polyester Resin 1073-5 is the non-air inhibited version of 1063-5. 1073-5 contains an additive to assure a tack free surface cure.

TYPICAL PROPERTIES

A. Unfilled Casting 1/8" Thick

1. Physical Properties

Barcol Hardness	50
Flexural Strength, 77°F., psi	13,000
Flexural Modulus, 77°F., psi x 10 ⁶	0.64
Flexural Strength, 175°F., psi	4,000
Flexural Modulus, 175°F., psi x 10 ⁶	0.16

K-14

Koppers Company, Inc., Pittsburgh, Pennsylvania 15219

TYPICAL PROPERTIES (Continued)

A. Unfilled Casting 1/8" Thick

1. Physical Properties

Tensile Strength, 77°F., psi	9,000
Elongation, %.....	1.9
Water Absorption, %, 24 hours @ 77°F.	0.11
Heat Distortion Temperature, °F.....	155
Specific Gravity	1.20
Shrinkage, % by Volume	7.8

B. Glass Mat Laminate 1/8" Thick

1. Physical Properties

Barcol Hardness	50/55
Flexural Strength, 77°F., psi	27,600
Flexural Modulus, 77°F., psi x 10 ⁶	0.97
Tensile Strength, 77°F., psi	17,900
Elongation, %	2.40
Izod Impact, Ft. Lbs./Inch, Notched	9.0
Water Absorption, %, 24 hours @ 77°F.....	0.13
Glass Content, %	30.0

C. Typical Gel Times, Minutes, 50 Gram Mass

Gel times are affected primarily by catalyst concentration, temperature and humidity. Typical gel times with temperature and catalyst concentration are shown below. These values should serve only as a guide since slight variations between lots of resin and catalyst do occur.

<u>% MEK Peroxide</u>	<u>65°F.</u>	<u>77°F.</u>	<u>90°F.</u>
0.50	-	30	15
1.00	30	17	10
2.00	18	10	-

X-13a

INFORMATION contained in this bulletin is presented in good faith, but it is not to be inferred that by publication hereof by Koppers Company, Inc., nor by the use or employment by the reader of any suggestions or method contained herein, that Koppers Company, Inc. has assumed any liability for infringement or alleged infringement of any patent, foreign or domestic, nor given any warranty, expressed or implied.

UNIGLASS®

UNIGLASS BOAT and TOOLING FABRICS

STYLE	COUNT	WARP YARN	FILLING YARN	WEAVE	WEIGHT (oz./sq. yd.)	THICKNESS (in.)	BREAKING STRENGTH (lb./in.)	FINISHED WEIGHT (oz./sq. yd.)
122	24 x 22	150 1/2	150 1/2	PLAIN	3.70	0.0055	160 x 135	3.60
1000	16 x 14	150 4/2	150 4/2	PLAIN	9.66	0.014	450 x 410	9.40
1033	16 x 14	150 3/3	150 3/3	PLAIN	11.00	0.016	455 x 400	10.50
1044	28 x 14	150 4/2	150 4/4	BASKET 2x1	18.00	0.022	745 x 830	17.55
1088	20 x 10	150 4/2	150 4/4	BASKET 2x1	12.65	0.018	475 x 500	12.25
1523	28 x 20	150 3/2	150 3/2	PLAIN	11.90	0.014	525 x 400	11.30
1525	30 x 24	150 1/2	150 1/2	PLAIN	4.50	0.006	195 x 155	4.23
1527	17 x 17	150 3/3	150 3/3	PLAIN	12.90	0.015	535 x 485	12.00
1534	16 x 14	150 4/2	150 3/4	PLAIN	12.00	0.016	460 x 685	11.60
1542	18 x 18	150 3/2	150 3/2	PLAIN	8.50	0.012	370 x 370	8.48
1548	42 x 21	150 4/2	150 4/2	MOCK LENO	20.80	0.028	965 x 525	19.75
1800	16 x 14	18 1/0	18 1/0	PLAIN	9.66	0.014	450 x 410	9.40
2532	16 x 14	25 1/0	25 1/0	PLAIN	7.50	0.010	335 x 316	7.05
2542	18 x 18	25 1/0	25 1/0	PLAIN	8.50	0.012	350 x 350	8.48
3000	30 x 30	75 2/4	75 2/4	SPECIAL	38.55	0.045	1375 x 1375	37.60
3722	18 x 18	37 1/0	37 1/0	PLAIN	6.00	0.009	250 x 220	5.64
7500	16 x 14	75 2/2	75 2/2	PLAIN	9.66	0.014	450 x 410	9.40
7522	18 x 18	75 1/2	75 1/2	PLAIN	6.00	0.009	250 x 220	5.64
7532	16 x 14	75 1/3	75 1/3	PLAIN	7.50	0.010	335 x 316	7.05
7542	18 x 18	75 1/3	75 1/3	PLAIN	8.50	0.012	370 x 370	8.48
7544	28 x 14	75 2/2	75 2/4	BASKET 2x1	18.00	0.022	745 x 830	17.55
7548	42 x 21	75 2/2	75 2/2	MOCK LENO	20.80	0.028	965 x 525	19.75
7549	30 x 28	75 1/2	75 1/2	SPECIAL	14.7	0.024	160 x 150	14.0
		BULKED	BULKED					

UNIGLASS WOVEN ROVINGS

STYLE	COUNT	ROVING	WEAVE	WEIGHT (oz./sq. yd.)	THICKNESS (in.)	BREAKING STRENGTH (lb./in.)
56	5 x 4	75's	PLAIN	22.8	0.038	1000 x 800
61	4 x 4	75's	PLAIN	18.0	0.032	800 x 500
62	5 x 3	75's	PLAIN	18.0	0.030	1000 x 200
709	7 x 4.5	75's	PLAIN	18.0	0.030	700 x 590

Fabric properties are based on loomstate (untreated) fabric unless otherwise noted; they are included for engineering information only, and are not intended to be guaranteed values.

K-16

GLASCOAT DIVISION
150 N.W. 176TH STREET
MIAMI, FLORIDA 33169
(305) 652-4100



UNIGLASS INDUSTRIES

DIVISION OF UNITED MERCHANTS AND MANUFACTURERS, INC.
1440 BROADWAY • NEW YORK, N.Y. 10018 • TEL. (212) 564-8000

Thalco DIVISION

6431 FLOTILLA STREET
LOS ANGELES, CALIFORNIA 90044
(213) 723-9151

CDRL A003
Code Ident 9243
M-24-6-678

APPENDIX L

DIELECTRIC CONSTANT AND DISSIPATION FACTOR
OF FOAM CORE/FACINGS

GENERAL DYNAMICS
Pomona Division

TECHNICAL MEMORANDUM

TM	24-6-776
MODEL	Naval Search Radome
CONTRACT	N66011-77-C-0139

DATE: 11 July 1978

TO: Mr. John Markall N.O.S.C. San Diego, CA.

FROM: Advanced Manufacturing Technology Dept. 24-6

SUBJECT:
Dielectric Constant and Dissipation Factors of Foam Core/Facings

REFERENCE:

DISTRIBUTION:
LIBRARY

PREPARED BY: W. L. MacTurk
W. L. MacTurk

PREPARED BY: _____

REVIEWED BY: _____

APPROVED BY: M. C. Abrams
M. C. Abrams

GENERAL DYNAMICS

Pomona Division

CDRL A002
Code Indent 9243
M-24-6-678

Dielectric Constant and Dissipation Factor of Foam/Facings

To verify the Koppers resin used in the construction of the polyester/glass cloth facings of the radome as to dielectric constant and loss tangent, a sample was prepared using a 181 glass cloth specified under Mil-C-9084 layed up as a laminate and utilizing the 1061-5 Koppers resin. Results are shown on Table 1. Attached to this appendix is also the vendor technical data sheet which meets Mil-R-21607B and Mil-R-7575C.

The vendor data sheet Stathane 6500 series is also attached to this appendix, and gives the values for the foam used in construction of the radome core materials. The 6502 foam (free rise) used in the radome core has a restrained density of 8 to 10 lbs/ft³ and conformed to the ϵ value checked by Manufacturing Technology. A slight increase was noted in the ϵ value checked by AMT and is due to formation of a rind at each interface where the foam action is impeded. This rind is solid resin in nature and causes the slight increase in the dielectric constant from the vendors figure, who utilizes a free rise foam where no rind occurs.

No ϵ or $\tan\delta$ values were available on the 4 oz glass cloth using the 1061-5 polyester resin with or without the gel coat application. Values found by AMT are also shown on Table 1.

Memo M-24-6-755 attached to this appendix explains the equipment and test procedures used and explains the equations used to derive the electrical properties required.

The loss tangent of the foam sample could not be checked at the vendor frequency of 9.375 GHz. Since the foam sample contains a large amount of air the loss tangent varies greatly with frequency.

GENERAL DYNAMICS
Pomona Division

CDRL A002
Code Indent 9243
M-24-6-678

Computing the copper losses of the dielectric constant checker at 9.375 GHz as $5 \times 10^{-3} \Omega$ (including skin effect) and taking the measured value of the capacitance of the foam sample as 2.265 pf then the capacitive reactance (X_c) at 9.375 GHz would be

$$X_c = \frac{1}{WC} = \frac{1}{6.28 \times 9.375 \times 10^9 \times 2.265 \times 10^{-12}} = 7.5 \Omega$$

The Q of the sample would then be

$$Q_d = \frac{X_c}{R} = \frac{7.5}{.005} = 1500$$

and $\tan \delta = \frac{1}{Q_d} = .00066$ a good approximation of the vendor value.

The radome value measured on the antenna range for RF transmission loss at 13.5 GHz supports this low electrical loss value where readings of less than 0.17 db were recorded across the frequency band.

Dielectric constant of total composite (foam core/gel coated glass sample) measured 1.45 on the dielectric constant checker, and can be verified from the following calculations:

$$C_{tc} = 1.15 \text{ pf} \quad (\text{capacitance of total composite}) \\ \text{picofarads}$$

$$C_{gf} = 14.24 \text{ pf} \quad (\text{capacitance of gel coated fiberglass facings}) \\ \text{picofarads}$$

$$\text{and } C_f = 1.25 \text{ pf} \quad (\text{capacitance of foam sample}) \\ \text{picofarads}$$

$$\text{Then } C_{tc} = \frac{14.24 \times 1.25}{14.24 + 1.25} = 1.15 \text{ pf}$$

and ϵ of the total composite would be

$$\epsilon = \frac{C_{tc}}{C_a} = \frac{1.15}{.795} = 1.45$$

Where C_a = Capacitance of air dielectric = .795 pf.

GENERAL DYNAMICS

Pomona Division

CDRL A002
Code Indent 9243
M-24-6-678

The loss tangent of the composite could not be measured at 13.5 GHz since the checker can only measure values at 1 MHz and no high frequency equipment was available.

Inspection of the dielectric constants low value for the total composite would indicate a low $\tan\sigma$ value and would be less than .001. This again is indicated by the low insertion value of the radome during test for transmission loss where values of less than 0.17 db were recorded. Maximum allowable insertion loss is 0.75 db.

ADVANCED MFG. TECHNOLOGY READINGS

	181 GLASS CLOTH LAMINATE	POLYESTER LAMINATE 4 oz. GLASS CLOTH WITH GEL COAT	POLYESTER LAMINATE 4 oz. GLASS CLOTH WITHOUT GEL COAT	E.R.P. 6502 2 lb/ft ³ POLYURETHANE FOAM. 9 lb/ft ³ RESTRAINED DENSITY
ε	4.20 (MIL. STD. REQUIREMENT) 4.0 - 4.2	4.06	4.07	1.25
TAN δ	0.13 (MIL. STD. REQUIREMENT) .020 MAX.	.010	.009	.015*

1-5

VENDOR SUPPLIER QUOTES

ε	4.16	** N.D.	N.D.	1.22
TAN δ	.008	N/D.	N.D.	.0006

* Could not be measured at vendor frequency of 9.375 GHz. Large volume of air in foam sample would necessitate this property being checked at that frequency.

** No Data

FIGURE 1

Mfg. Tech. M-24-6-755
October 1962

DIELECTRIC CONSTANT CHECKER TO MEASURE
HIGH FREQUENCY STRIPLINE SUBSTRATES

In Stripline Technology where electromagnetic energy travels through the substrate guided by copper conductors sandwiched between ground planes a knowledge of the substrate dielectric constant and loss tangent is very important since they directly affect design parameters in this fast growing stripline field.

Since the dielectric constant (ϵ) of a material is directly related to capacitance and the loss tangent directly related to useful energy lost in a substrate through heating these characteristics must be readily identified on board material supplied by a vendor.

Consequently Manufacturing Technology built a dielectric constant checker. (See Figure 1). This unit has a micrometer adjustment which regulates a moveable upper copper plate. The bottom copper plate is stationary and the whole unit is encased in a Teflon block, supported by an aluminum plate. The accuracy of this unit is within 1%. The dielectric constant checker is used in conjunction with a Boonton Q Meter, Type 260A and all measurements were taken at 1 MHz.

All dielectrics checked were 1" square and approximately 1/16" thick.

The Q meter is made to resonate with the coil and the internal capacitance of the Q meter. The dielectric constant checker, with the specimen inserted in the checker, is then measured for capacitance. The specimen is removed and with the same micrometer adjustment, another capacitance measurement taken. This gives the necessary data for accurate measurement of the specimen including the associated capacitances and fringe capacitance of the checker. A series of simple equations is

then derived to arrive at the correct dielectric constant. A 1" square, 1/16" thick Teflon fiberglass laminate with a vendor specification on the dielectric constant of $2.6 \pm .05$, was then checked as follows on the Q meter at 1 MHz to verify the instruments accuracy.

$C_1 = 93.8 \text{ pf} = \text{Capacitance of Q Meter at resonance with coil (Picofarads)}$

$C_2 = 79.7 \text{ pf} = \text{Capacitance of checker and specimen across the coil}$

$C_3 = 86.7 \text{ pf} = \text{Capacitance of checker without specimen}$

Consequently:

$$C_d + C_f = C_1 - C_2 = 14.1 \text{ pf} \quad \text{Equation 1}$$

And:

$$C_a + C_f = C_1 - C_3 = 7.1 \text{ pf} \quad \text{Equation 2}$$

Where:

$C_d = \text{Capacitance of dielectric specimen in picofarads}$

$C_f = \text{Fringe and associated capacitances in picofarads}$

$C_a = \text{Air capacitance of dielectric in picofarads}$

Subtracting equation 2 from equation 1 gives:

$$C_d - C_a = 7 \text{ pf}$$

AND:

$$C_d = 7 \text{ pf} + C_a$$

Since the air capacitance is taken from the classical formula of:

$$C_a = \frac{.225 \times \epsilon \times A}{t}$$

Where $\epsilon = \text{dielectric constant of air (vacuum)} = 1$

$A = \text{area of specimen (square inches)} = 1 \text{ sq. in.}$

$t = \text{thickness of specimen (inches)} = .052''$

Which gives $C_a = 4.327$

The dielectric constant of the specimen is the capacitance of the dielectric over that of air which is:

$$\epsilon = \frac{C_d}{C_a} = \frac{7 + 4.327}{4.327} = 2.617$$

Since the specimen checked must conform to a specification giving a dielectric constant of 2.6 with a tolerance of $\pm .05$, this shows the accuracy of checking the dielectric constants of low loss materials by the method devised by Manufacturing Technology.

The loss tangent is computed from taking the Q of the specimen being measured where:

$$Q_d = \frac{Q_1 Q_2 (C_d)}{Q_3 (C_1 - C_2 + C_a)}$$

And where the loss tangent

$$\tan \delta = \frac{1}{Q_d}$$

Figure 2 lists some of the materials checked by Manufacturing Technology for dielectric constant and loss tangent.

The accuracy of the loss tangent measurements at 1 MHz are within 1%. At high frequencies, (X band) the loss tangent measurements should be accomplished by high frequency stripline techniques using a bridge circuit. Most vendors check their low loss dielectrics at X band frequencies.

W. L. MacTurk

W. L. MacTurk
Advanced Manufacturing Technology

GENERAL DYNAMICS

Pomona Division

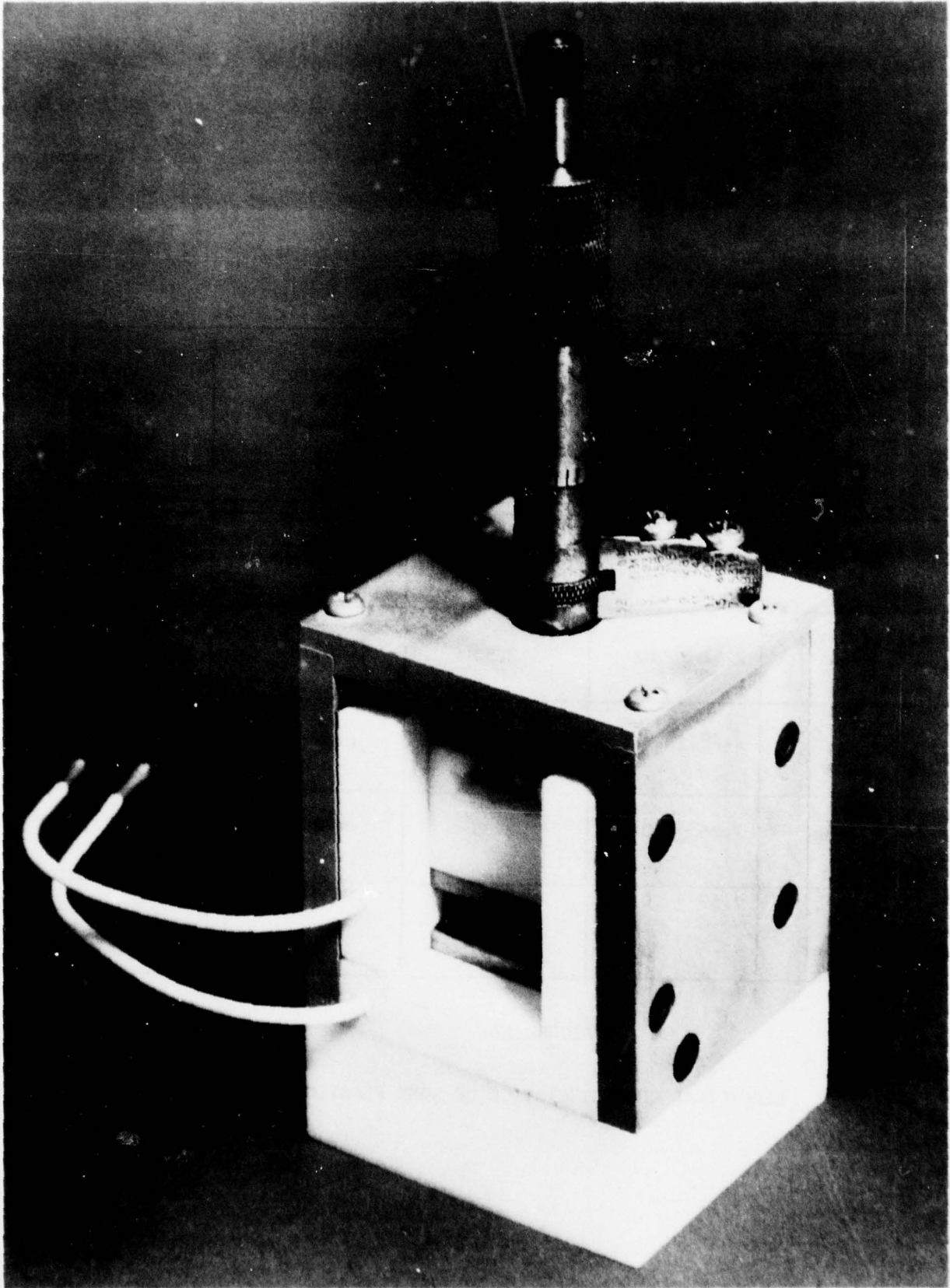

12-69-53517

L-9

DIELECTRIC CONSTANT CHECKER

Mfg. Tech. M-24-6-755
24 May 1978

MATERIAL	MEASURED DIELECTRIC CONSTANT	CATALOG QUOTED DIELECTRIC CONSTANT	MEASURED LOSS TANGENT	CATALOG QUOTED LOSS TANGENT
Teflon	$2.1 \pm .02$	2.09	.00018	Less than .0002
Rexolite 1422 (Brand Rex)	$2.51 \pm .02$	2.53	.00011	.00012
Rexoline S (Brand Rex)	$2.30 \pm .02$	2.32	.00011	.00004
Polyethylene 7000 (3M)	$2.36 \pm .02$	2.35	.0001	.00007
GB 112T Continental Diamond Fiber	$2.53 \pm .02$	2.53	.00316	.0015

FIGURE 2

ELECTRICAL CHARACTERISTICS OF SOME PLASTICS

KOPPERS

Polyester Resins

TECHNICAL DATA
SHEET

MARCH, 1972

RESINS QUALIFIED UNDER MILITARY SPECIFICATION MIL-R-21607-B and MIL-R-7575-C

Koppers now has five polyester resins qualified under military specification MIL-R-21607B. These are resins 1000, 2000, 3401, and 3403.

There is no longer a QPL (Qualified Products List.) Qualification and approval are based on preproduction testing by the customer or by an independent, certified testing laboratory. The testing of Koppers' polyester resins was done by CTL-Dixie, Inc. (formerly the Cincinnati Testing Laboratories.) A summary of their test results is given in an attachment.

MIL-R-7575C divides polyester resins into two grades: Grade A - normal mechanical properties, and Grade B - improved mechanical properties. All five of Koppers' qualified resins meet Grade A specifications and all but 3401 meet Grade B specifications when given a post cure.

MIL-R-7575C further classifies polyester resins according to dielectric constant of a laminate. Two of Koppers' resins (2000 and 3401) fall into Class 1 (dielectric constant 3.6 to 4.0), and two (1000), fall into Class 2 (dielectric constant 4.0 to 4.2). Koppers resin 3403 meets Class 3 requirement (dielectric constant 4.2 - 4.4).

Koppers Polyester Resin 1000 meets Grade A and B, Class 2, requirements
Koppers Polyester Resin 2000 meets Grade A and B, Class 1, requirements
Koppers Polyester Resin 3401 meets Grade A, Class 1, requirements
Koppers Polyester Resin 3403 meets Grade A and B, Class 3, requirements
All five resins meet Class 0 requirements.

Resin which is to be certified as meeting MIL-R-7575C requirements must be ordered specifically as Mil Spec material. The specifications for the Mil Spec grade resins are given below:

	1000	2000	3401	3403
Monomer	Styrene	Styrene	Styrene	Styrene
Viscosity, 77°F., poises	9-13	9-13	9-13	9-13
Specific Gravity	1.11-1.13	1.11-1.13	1.25-1.28	1.33-1.37
Acid Number - Solution - Max.	15	15	15	15
Color, APHA - Max.	150	150	light straw	light straw
SPI Cure Data				
Time to gel, minutes	3-5	3-5	3-5	3-5
Time to peak, minutes	5½-7½	5-7	4-6	4½-6½
Peak temperature, °F.	365-395	395-430	410-450	410-450

Resins 1000, 2000 and 3403 are also available in open mold versions: Mil Spec 1060 Mil Spec 2060, and MIL Spec 3463-M.

L-11

Koppers Company, Inc., Pittsburgh, Pennsylvania 15219

MILITARY SPECIFICATION

Laminates were made in accordance with paragraph 4.3.1 of MIL-R-7575C using 181/S-910 glass fabric certified under MIL-C-9084. The resins were used at 10-12 poises viscosity and were catalyzed with 1% benzoyl peroxide (100% active basis). The molding cycle was 10 minutes at 225-235°F. Laminates for Grade B were given a one hour post cure at 200°F.

Property	Specification Requirements		CTL-Dixie Test Results*			
	Grade A	Grade B	1000	2000	3401	3403
Flexural strength, flatwise						
Ultimate strength, psi	50,000	65,000	77,120	73,870	72,530	68,990
Flexural modulus of elasticity, psi x 10 ⁶	2.7	3.2	3.3	3.2	3.1	3.2
Tensile strength, psi	40,000	50,000	50,500	53,030	51,710	50,260
Compressive strength, edgewise, psi	35,000	45,000	48,770	59,710	48,860	45,450
Flammability, inches per minute	1.0 max.	1.0 max.	0.44	0.42	S.E.	S.E.
Water absorption, 24 hr. immersion, % change in wt.	±0.5 max.	±0.5 max.	0.046	0.042	0.034	0.159
Barcol Hardness	55	55	66	59	68	65
Specific gravity	no spec	no spec	1.782	1.811	1.878	1.901
Resin content	no spec	no spec	39.2	37.5	41.6	41.4
Tested Wet after 2 hour immersion in Boiling Water						
Flexural strength, flatwise						
Ultimate strength, psi	45,000	60,000	78,520	70,370	69,980	67,380
Flexural modulus of elasticity, psi x 10 ⁶	2.5	3.1	3.2	3.1	3.1	3.2
Tensile strength, psi	38,000	48,000	52,760	50,790	48,350	48,920
Compressive strength, edgewise, psi	30,000	40,000	49,820	52,590	46,910	41,950
Tested at 70°C. after ½ hour Exposure at 70°C.						
Flexural strength, flatwise						
Ultimate strength, psi	40,000	44,000	58,390	64,940	57,390	55,070
Flexural modulus of elasticity, psi x 10 ⁶	2.3	2.6	2.6	2.8	2.7	2.8
Tested after Immersion in Chemical Fluids						
Hydraulic Fluid						
% change in weight	0.2 max.	0.2 max.	0.017	0.030	0.018	0.033
% change in thickness	0.2 max.	0.2 max.	0	0	0	0
Ultimate flexural strength, psi	no spec	no spec	72,250	73,400	73,150	71,470
Isopropyl alcohol						
% change in weight	0.1 max.	0.1 max.	0.018	0.031	0.021	0.021
% change in thickness	0.1 max.	0.1 max.	0	0	0	0
Ultimate flexural strength, psi	no spec	no spec	76,780	74,720	75,650	67,210
Hydrocarbon Test Fluid						
% change in weight	0.1 max.	0.1 max.	0.003	0.001	0.011	0.004
% change in thickness	0.1 max.	0.1 max.	0	0	0	0
Ultimate flexural strength, psi	no spec	no spec	76,500	73,760	72,450	69,820
Dielectric Constant						
Standard conditions						
Class 1	3.6-4.0			3.77	3.77	
Class 2	4.0-4.2		4.16			
Class 3	4.2-4.4					4.22
Dissipation Factor	0.020 max.		0.008	0.009	0.013	0.015
Immersion conditions	Not greater than 5% increase over "as received."		4.19	3.81	3.97	4.31
Dissipation Factor	0.025 max.		0.009	0.011	0.020	0.022
MIL-R-21607A Flame Resistance						
Class A - translucent laminate						
Time to ignition, seconds	55 min.				101	61
Burning time, seconds	125 max.				87	84
Class B - opaque laminate						
Time to ignition, seconds	70 min.					
Burning time, seconds	65 max.					

*Average of the specified number of test samples.

INFORMATION contained in this bulletin is presented in good faith, but it is not to be inferred that by publication hereof by Koppers Company, Inc., nor by the use or employment by the reader of any suggestions or method contained herein, that Koppers Company, Inc. has assumed any liability for infringement or alleged infringement of any patent, foreign or domestic, nor given any warranty, expressed or implied.

PHYSICAL PROPERTIES
STATHANE 6500 SERIES

Note: All results represent averages of various batches of materials run on free rise core density samples. Samples were obtained from 14" x 14" x 6" blocks prepared in the laboratory.

System Code	6502	6504	6506	6508	6510	6512	6520
Nominal Density, Lbs/Ft ³	2	4	6	8	10	12	20
Compressive Strength, PSI @ Yield point II to foam rise @ 77°F	30	80	140	240	315	480	900
Tensile Strength, PSI, Ult. @ 77°F, II to foam rise	40	110	155	210	250	310	570
Tensile Modulus, PSI II to foam rise @ 77°F, x 10 ⁷	0.5	0.8	1.3	2.2	3.3	5.0	16.0
Shear Strength, PSI II to foam rise @ 77°F	26	58	74	120	160	215	560
Dielectric Constant at 9.373 KMC	1.04	1.08	1.12	<u>1.18</u>	<u>1.22</u>	1.26	1.33
Loss Tangent at 9.373 KMC, x 10 ⁻³	0.5	0.5	0.6	0.6	0.8	0.9	2.4
K - Factor - BTU/HR/FT ² /IN/ ^o F	0.17	0.18	0.19	0.19	0.21	0.23	0.25
Flammability Per ASTM 1692-67T	SE	SE	SE	SE	SE	SE	SE
Volume change after Humid aging per Mil- P-21929	±6%	(2 lbs/ft density only)					
Change in Compr. Strength per Mil-P-21929	-5%	(2 lbs/ft density only)					

The information contained in this literature is to the best of our knowledge, true and accurate. Since conditions of use are beyond our control, all recommendations and suggestions are made without guarantee. Expanded Rubber and Plastics Corporation disclaims any liability for the use of these suggestions or data. Nothing contained herein is a recommendation to use any product in conflict with the third parties patent rights. All products should be used only under well ventilated conditions.

CDRL A003
Code Ident 9243
M-24-6-678

APPENDIX M

WEIGHT OF SEARCH RADOME

GENERAL DYNAMICS
Pomona Division

TECHNICAL MEMORANDUM

TM
24-6-778
MODEL
Naval Search Radome
CONTRACT
N66011-77-C-0139

DATE: 11 July 1978

TO: Mr. John Markall N.O.S.C. San Diego, CA

FROM: Advanced Manufacturing Technology Dept. 24-6

SUBJECT:

Weight of Search Radome

REFERENCE:

DISTRIBUTION:
LIBRARY

PREPARED BY: W. L. MacTurk
W. L. MacTurk

PREPARED BY: _____

REVIEWED BY: _____

APPROVED BY: M. C. Abrams
M. C. Abrams

GENERAL DYNAMICS

Pomona Division

CDRL A002
Code Indent 9243
M-24-6-678

WEIGHT OF NAVAL SEARCH RADOME

Drawing number 5188237 defines the maximum weight of the radome as 15.8 lbs.

Commensurate with structural requirements Manufacturing Technology has strived to keep this weight below 13.0 lbs the original vendor honeycomb design weight which could not be met and also to reduce servo structure inertia to the minimum.

Density of the 4 oz glass cloth and polyester resin used on the present design at a percentage glass to resin weight of 70:30 is .05 lbs/in³. This in a controlled temperature environment in the new Phalanx Fiberglass Facility now in production can be easily met.

Computing the weight of the search radome with a foam weight of 2.85 lb₃ which meets the restrained foam density₃ of 11 lbs/ft³ ± 3 lbs/ft³ and a glass/resin density of .05 lbs/in³ would give,

$$\begin{aligned}\text{Weight of inner facing} &= V_1 d = 2 \pi r^2 t d \\ &= 6.28 \times (19.74)^2 \times .035 \times .05 = 4.28 \text{ lbs}\end{aligned}$$

where V_1 = Volume of inner facing (in³)
and d = density of glass/resin
and t = thickness of facing. (inches)

$$\text{Weight of outer facing} = V_2 d = 6.28 \times (20)^2 \times .035 \times .05 = 4.4 \text{ lbs}$$

Weight of milled fiber/resin mix in hard points = .30 lbs.

Weight of polyurethane elastomer sealant = .09 lbs.

Total computed weight of radome = 11.92 lbs.

Weight of radome measure on a calibrated 20 Kg Ohaus balance read 11.875 lbs the difference in weight being the enlargement of the hard point mounting holes from .125" to .219" for handle and latch attachment after hard point cure.

CDRL A003
Code Ident 9243
M-24-6-678

APPENDIX N

TORSION REQUIREMENTS ON HARD POINTS OF RADOME

GENERAL DYNAMICS
Pomona Division

TECHNICAL MEMORANDUM

TM
24-6-779
MODEL
Naval Search Radome
CONTRACT
N66011-77-C-0139

DATE: 10 July 1978

TO: Mr. John Markall N.O.S.C. San Diego, CA

FROM: Advanced Manufacturing Technology Dept. 24-6

SUBJECT: Torsion Requirements on Hard Points of Radome

REFERENCE:

DISTRIBUTION:
LIBRARY

PREPARED BY: W. L. MacTurk
W. L. MacTurk

PREPARED BY: _____

REVIEWED BY: _____

APPROVED BY: M. C. Abrams
M. C. Abrams

AD-A068 672

GENERAL DYNAMICS/POMONA CALIF POMONA DIV
FOAM-FILLED FIBERGLASS RADOMES.(U)

F/G 11/5

UNCLASSIFIED

MAR 79 W L MACTURK
M-24-6-678

NAVSEA-MT-100

N66001-77-C-0139
NL

3 OF 3

AD
A068672

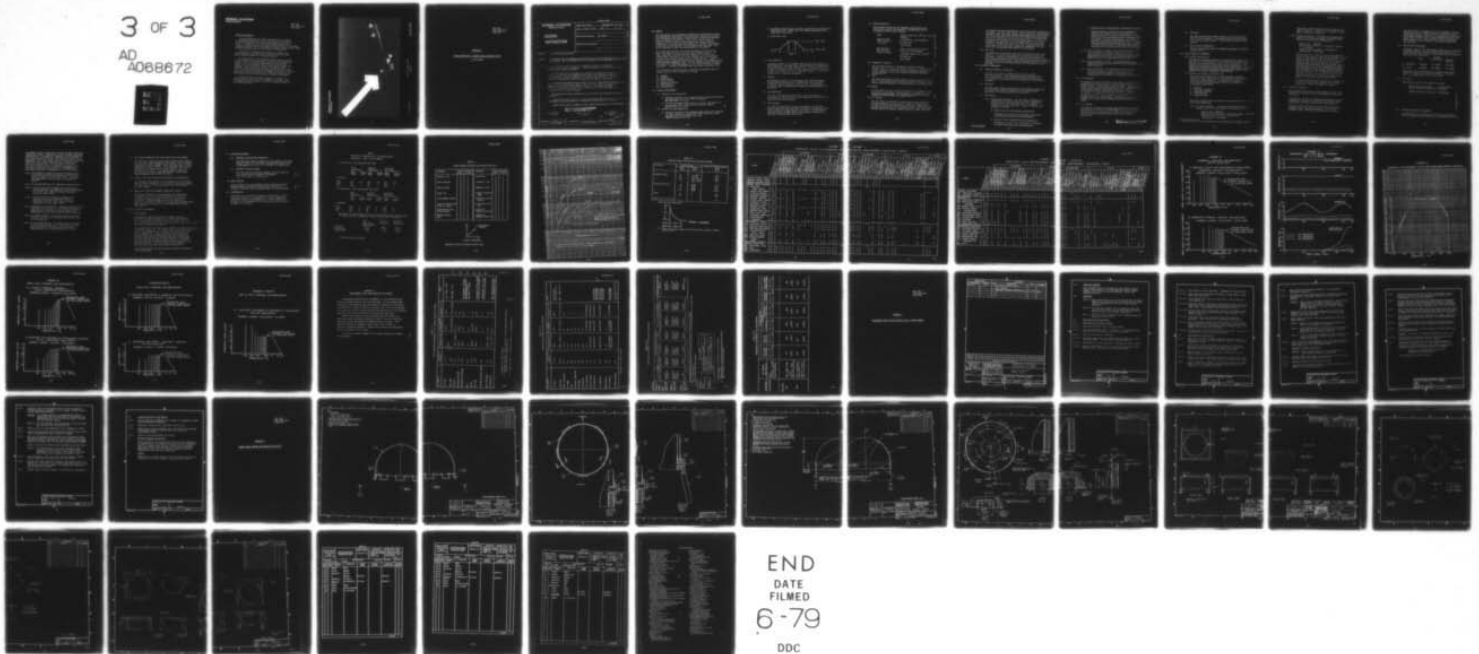

END
DATE
FILMED
6-79
DDC

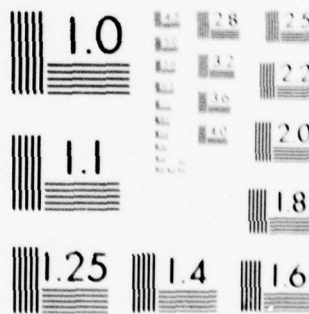

MICROCOPY RESOLUTION TEST CHART
NATIONAL BUREAU OF STANDARDS-1963-A

GENERAL DYNAMICS

Pomona Division

CDRL A002
Code Ident 9243
M-24-6-678

Torque Requirements

Torque requirements on screws attaching both the handles of the radome and the latch plates were given as 27 in/lbs and 16 in/lbs respectively on a previous honeycomb design from a vendor. Consequently these requirements were reflected on the foam/fiberglass Phalanx ClWS search radome P/N 5188237, and the naval radome tested accordingly since it is of identical construction.

Utilizing a calibrated torque wrench, all handles and latch plates were installed with screws and lock nuts on the naval fiberglass radome to the values required.

No delamination of the fiberglass facings from the poured-in-place hard points was observed on removal of the handles and latches. Also no cracking or dimpling of the facings was evident and it was concluded that a large margin of safety was inherent in this design with regards to the torque values required. This was proven by torquing one #10 screw to a value of 51 in/lbs when the nut threads stripped from the screw with no deleterious effects occurring to the fiberglass facings or the polyester/milled fiber construction of the hard point bosses.

Another #10 screw was again torqued to 51 in/lbs at a handle attachment where the screw snapped at the shank. This is adequately shown in Figure 1, with no detrimental effect to the radome hard point.

GENERAL DYNAMICS
Pomona Division

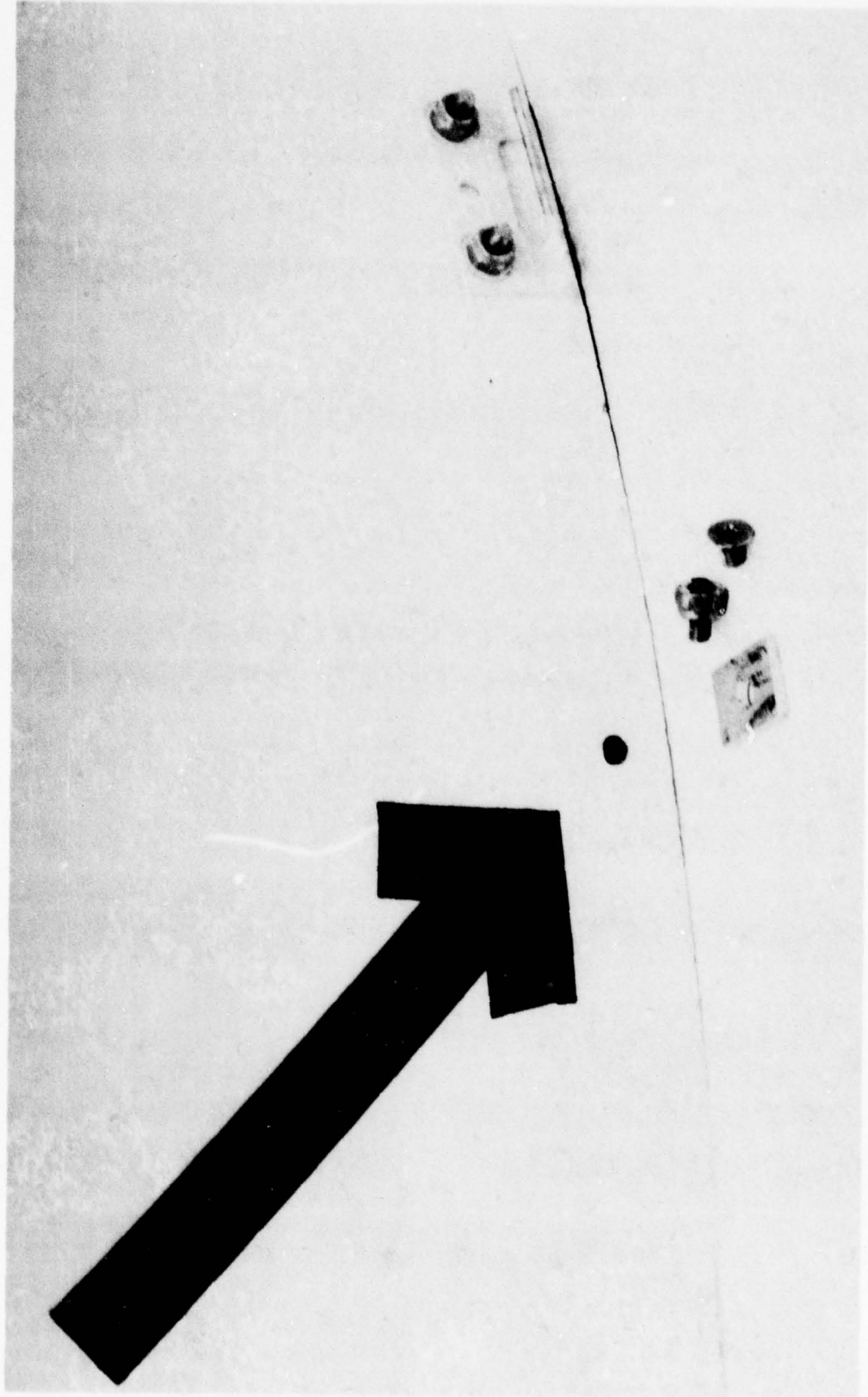

TOSSION REQUIREMENTS
ON HARD POINTS TEST

NAVAL SEARCH RADOME
FIGURE 1

P.O. 5-78-81670

CDRL A003
Code Ident 9243
M-24-6-678

APPENDIX O

DESIGN INSTRUCTION - PHALANX CLOSE-IN-WEAPON SYSTEM

DI 444-A-002A

GENERAL DYNAMICS*Pomona Division***DESIGN
INSTRUCTION**

MODEL Pilotline NO. _____ SUPERSEDED NO. 433-BE-086D

DATE 5 January 1977 PAGE 1 OF 30

SPECIFICATION REFERENCE WS 13902D

SUPPORTING DATA REFERENCE _____

SUBJECT: CIWS PILOTLINE ENVIRONMENTS

PURPOSE: To establish the environmental requirements for CIWS pilotline equipment assemblies and packages, and to standardize the test methods for environmental qualification.

INSTRUCTION: All pilotline specifications for equipment assemblies and packages are to be compatible with these environments. (The environments for purchased piece parts are contained in DI-433-BE-332).

The CIWS Pilotline environments are defined in Paragraphs 1.0 through 5.0. The test methods for environmental qualification are contained in Appendix A. These tests are in terms of military or industry test methods. This allows the use of standard test methods and set-ups and reduces testing costs.

Gun induced environments are provided for both 25 mm and 30 mm (GAU-8A) growth guns. The 30 mm environments apply only to the outer structure (barbette, electronics enclosure, train platform, and elevation mount structure). The yoke, elevation gear train, servo motors and all of the electronics are designed for the 25 mm environments.

The allocation of the environments to the various CIWS elements is provided in Figure 1.

Load distributions in terms of shear and bending moments due to combined load environments (survival) and near miss shock are contained in DI-444-A-003.

Table A-IV provides a summary of the thermal environments for CIWS packages.

**THIS PAGE IS BEST QUALITY PRACTICABLE
FROM COPY FURNISHED TO DDC**

"A" MAT"A" RAE"A" CRH
4-27-77

0-1

XIV-2

PREPARED BY

SECTION 346

APPROVED BY

SYSTEMS ENGINEERING

APPROVED BY

PROJECT OFFICE

1.0 GENERAL

The CIWS system will be deployed on board many different ship classes. The geographical deployment of the CIWS and its supporting logistics will be worldwide and climatic conditions will range from equatorial heat and humidity conditions to arctic cold. The CIWS must be capable of effective and continuous operations under realistic combinations of its own ship environments, the climatic environments as specified in MIL-STD-210, the environments that the enemy forces can be expected to induce and self-generated environments.

The system shall operate with normal performance when performing under environmental conditions noted under "Normal Service." In those cases where "Reduced Operating Capability" is noted, the system shall function but it is not required that the performance be within the tolerances specified for "Normal Service." Reduced capability may include reduced elevation coverage, kill probability and altered minimum engagement range. In the cases specifying "Withstand," the system is to withstand exposure to the conditions without damage and recover to normal performance when less severe conditions exist.

The environmental requirements are organized in accordance with the primary source of the environment as follows:

- a) climatic
- b) shipboard
- c) CIWS generated
- d) threat induced
- e) combination loading
- f) bench handling
- g) transportation

2.0 CLIMATIC ENVIRONMENTS

2.1 Thermal Air Low Temperature

- a) Equipments exposed to the elements shall operate with external air temperature at -28°C (-19°F) continuous. (MIL-STD-210B, 5.2.2.2.2).
- b) The CIWS equipments shall be able to survive (not operate in) a continuous -40°C (-40°F) without permanent damage. (MIL-STD-210B, 5.2.2.2.3)

2.2 Thermal Air High Temperature

- a) Equipments exposed to the elements shall operate with external air high temperatures between 32°C (90°F) and 46°C (114°F) according to the below daily duty cycle (MIL-STD-210B, 5.2.2.1.2).

- b) Equipments shall be able to survive a continuous air temperature high between 32°C (+90°F) and 71°C (160°F) according to the below daily duty cycle.
- c) Daily duty cycle

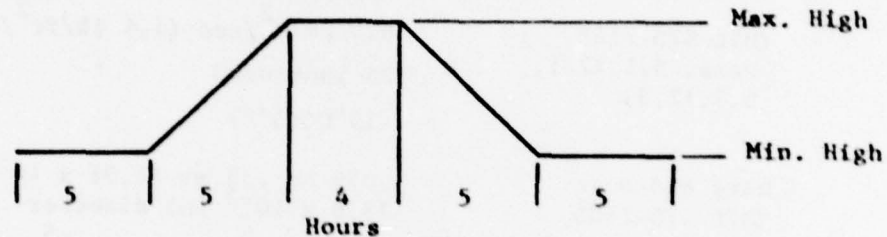

2.3 Solar Radiation

Equipments exposed to the elements shall operate when exposed to solar radiation. The solar power will vary from 0 to 90 watts/ft² in accordance with the duty cycle of 2.2. This requirement shall be used in conjunction with 2.2 when computing surface temperatures. Composition of solar energy is: 51 percent infrared, 44.5 percent visible, and 4.5 percent ultraviolet.

2.4 Humidity

The equipments exposed to the elements shall maintain normal service when operating either intermittently or continuously at ambient relative humidity from 5% to 95%. Packaged parts in storage shall withstand any continuous relative humidity from 95% to 2%.

2.5 Sea Temperature

The CIWS shall maintain normal service when sea water at a temperature of 38°C (100°F) or less is used as the basic cooling source for any cooling system.

2.6 Wind Loading

The CIWS shall maintain its normal performance in turbulent smooth winds with velocities up to 75 knots (17 pounds per square foot on projected areas exposed to the wind). The CIWS shall withstand without damage, winds having relative velocities of 100 knots (30 pounds per square foot).

2.7 Blowing Particles

The external portions of the equipment including RV front panels shall operate when exposed to blowing particles in accordance with the below schedule:

Snow:	.02 to .2 mm (7.9×10^{-4} to 7.9×10^3) diameter	A
(MIL-STD-210B, Para. 5.1.12.1, 5.1.12.3)	6.9 gm/m ² /sec (1.4 lb/ft ² /sec) 26 knot wind -15°C (5°F)	
Sand and Dust:	.074 to .35 mm (2.91×10^{-3} to 13.8×10^{-3} in) diameter	
(MIL-STD-210B, Para. 5.1.21.3)	1.06 gm/m ³ (6.61×10^{-5} lb/ft ³) 35 knot wind 21°C (70°F)	

2.8 Atmospheric Pressure

The CIWS shall operate in atmospheric pressures varying between 12.8 to 15.4 psia (26.06 to 31.35 in Hg). Packaged parts in Navy logistics system must survive atmospheric pressures as low as 1.68 psia (3.42 in Hg, 50,000 ft altitude) during air transportation.

2.9 Rain

The CIWS shall maintain normal service in rain of up to 4 mm per hour. The equipment shall withstand rainfall rates up to 7 inches per hour with an average of 1 inch per hour for a 12 hour period.

2.10 Fungus

The CIWS shall use fungi resistant materials in accordance with MIL-STD-454, Requirement 4 where possible. Equipment with non-resistant materials shall not show deterioration after being subjected to MIL-STD-810, test method 508.1.

2.11 Ice Loading

The CIWS shall be capable of operation under icing conditions. Ice may accumulate at rates up to 1 in/hr on surfaces that do not utilize ice build-up prevention techniques. Means shall be provided for prevention of icing and/or for de-icing of adjoining surfaces which are required to move relative to each other and

on surfaces on which accumulations of ice will prevent satisfactory operation. The CIWS shall operate normally with all surfaces except the search and track radar windows, gun, magazine and yoke covered with 4.5 lb per square foot of ice on all horizontal surfaces and 2.25 lb per square foot on all vertical surfaces. The CIWS shall survive an ice loading of 6.0 lb per square foot of ice on all horizontal surfaces and 3.0 lb per square foot on all vertical surfaces. (MIL-STD-2103, Para. 5.2.2.13.3) During system operation under icing conditions, minimum air temperature will be -18°C (0°F) and maximum wind speed will be 50 knots. A

2.12 Salt Fog

The enclosures of equipment shall resist deterioration when subjected to a 5 percent sodium chloride solution for a period of 200 hours. Interior equipment^x shall show no deterioration and shall maintain normal service when subjected to a 5 percent sodium chloride solution for 48 hours. Interior equipment having 2 enclosures between it and the outside atmosphere shall not be subjected to a salt fog test. A

3.0 SHIPBOARD ENVIRONMENTS

3.1 Shipboard Magnetic Conditions

The CIWS shall operate normally when subject to slowly fluctuating direct current induced degaussing magnetic fields up to 20 gauss max. The CIWS shall be capable of returning to operation as specified within 60 minutes after the deperming operation.

3.2 Gun Blast

The CIWS shall maintain normal service when subject to gun blast of 7.5 psi with a positive impulse of 10 psi-milliseconds repeated at 40 times per minute for 10 minutes.

3.3 Ship Motion

3.3.1 Ship Motion Conditions. The CIWS shall be designed for installation in various classes of ships. Ship motion characteristics vary with ship class. For design purposes the motions described in Table I shall be used, combined as follows:

a) Normal Service (Full Operating Capability)

Maximum roll, pitch and yaw positions, velocities, or accelerations may occur simultaneously.

b) Reduced Service (Reduced Operating Capability)

Maximum roll, pitch, and yaw positions, velocities or accelerations may occur simultaneously.

y Enclosures

c) Extreme Service (Non-Operating, Withstand and Recover)

Maximum positions, velocities, and accelerations shall not be assumed to occur simultaneously. The maximum position, velocity, or acceleration about any one of the axes (for extreme service condition) shall be assumed to combine simultaneously with maximum positions, velocities and accelerations of the normal service condition about the other two axes. Recovery to normal operation shall be automatic and within 1 second after an extreme service condition is removed.

- 3.3.2 Ship Inclination, Operate. The group shall operate with ship continuous inclinations of ± 15 degrees list (roll) and ± 5 degrees trim (pitch). When ship inclinations are combined with ship motions, ship amplitude extremes of Table 1 are the limits specified for operation.
- 3.3.3 Ship Inclination, Survive. The CIWS equipment shall withstand a 60 degree roll when it is in a non-operating or stowed condition.
- 3.3.4 Ship Turning Rate. The group shall operate normally for ship turning rates of 5 deg/sec for a maximum of 40 seconds. The system shall be capable of reduced performance for turning rates of 18 deg/sec for a maximum of 10 seconds.

3.4 Ship Vibration

The equipment with the exception of the cannon (M51A1) and its magazine shall withstand Type 1 vibration requirements as specified in MIL-STD-167B. The vibration levels of Table II are expected during vibration qualification per MIL-STD-167B. Equipment is to operate with acceptable performance during two hours of vibration at the maximum levels indicated along each axis. The table II vibration levels represent test levels and not normal shipboard operational levels. During maneuvers in rough seas the levels will be about half of the table values. During calm seas and steady heading of the ship, the levels will be about one-tenth of those shown.

3.5 Wave Loading

The CIWS top side mount enclosures shall withstand a wave load equivalent to a static load of 1000 pounds per square foot on vertical projected areas except the radar servo structure which shall withstand an equivalent static load of 500 pounds per square foot.

3.6 Sea State

The CIWS shall maintain normal service in any sea state from zero to five (inclusive). Maintenance shall not be performed in a sea state greater than 5. The survival sea state is sea state 8.

3.7 Ship Internal Temperature

The LCP shall operate with air temperature between 0° and 50°C (32 and 122°F).

4.0 CIWS GENERATED ENVIRONMENTS

4.1 Acoustic Environments

The CIWS shall operate normally in its own acoustic environment and when in close proximity to other equipment generating noise. The free-field peak levels for nearby jet aircraft and missile launch can be as high as 160 dB and 164 dB, respectively. The CIWS shall not generate noise above 95 dB except when firing. Equipment in enclosed areas shall not generate airborne noise in excess of that permitted for Grade C equipment in MIL-STD-740.

4.2 Acoustic Environment for Growth Guns

The Pilotline configuration is to be designed to minimize future structural changes due to the more severe environments that result from up-gunning. As indicated in Figure 1, the following structural elements are to be designed for the 30 mm growth requirements:

- a. Barbette
- b. Electronic enclosure
- c. Equipment platform
- d. Train platform
- e. Elevation mount

All other structure and all electronic components are to be designed for a 25 mm growth gun.

4.2.1 25 mm Gun Acoustics. 25 mm gun environments are based based on early GAU-7 and caseless ammunition data including:

Rate of fire: 3000 SPM
 Muzzle position relative to elevation turnion: 83 inches
 Projectile kinetic energy: 106,000 FT-LB
 Charge weight: 2450 grains

* Sound pressure levels in decibels (dB) are referenced to 0.0002 dynes/cm².

The interior acoustic levels for the 25 mm gun are shown in Figure 2. These are to be applied to equipment as indicated in Figure 1.

4.2.2 30 mm Gun Acoustics. The design for a growth gun is based on the GAU-8A environment. Significant parameters for the acoustic environment are:

Rate of fire: 3000 SPM
Muzzle position relative to elevation trunnion:
65 inches
Projectile kinetic energy: 148,200 FT-LB
Charge weight: 2400 grains

Maximum blast loads induced by the 30 mm growth gun on the external structure and the firing angles at which they occur are shown in Table III and Figure 3. The reflected blast loads on the electronics enclosure can be as great as 40 to 60 psi for -25 degrees elevation and train angles near 165 degrees. Due to the low probability of ship installations permitting this condition to occur, the electronics enclosure will be designed for the maximum reflected pressure of 11 psi that occurs at -25 degrees elevation and ± 120 degrees train. Beyond ± 120 degrees train, the elevation angle must be increased to 0 degrees in order not to exceed the 11 psi design load.

The CIWS external structure shall have a fatigue life in excess of 2 hours when exposed to the 30 mm acoustically induced environment of Figure 4.

4.3 25 mm Gun Vibration

The equipment shall operate normally when subjected to the appropriate 25 mm gun vibration environments as specified in Figure 5.

The vibration consists of narrow band random and sinusoidal components at all gun fire harmonics below 1000 Hz and a predominantly broadband random content above 1000 Hz.

Vibration varies with position in the CIWS structure and according to the mounting provisions for the various equipment items. Vibration envelopes given in Figure 5

are specified at the package side of the designated isolators. Vibration levels or components within the packages can be substantially higher. Gains of 3 to 10 apply for conventional lowly damped packaging while highly damped designs will have gains from 1.5 to 3. Use of internal vibration isolation may be warranted where components have unusual sensitivity to vibration.

4.4 Mount Motion Environment

Equipments housed in the CIWS radome assembly shall be designed to operate under the loading induced by base motion of the mount elevation and train axes. These axes have the below slew and acceleration capability.

	Slew	Maximum Acceleration	Slew into Buffers
a) Elevation	1.6 Rad/s	14 Rad/s ²	1.6 Rad/s
b) Train	2.2 Rad/s	14 Rad/s ²	2.2 Rad/s

Mechanical stop is accomplished at constant deceleration ($\pm 10\%$) in 5 degrees in train and 10 degrees in elevation. The CIWS components must survive this shock.

4.5 Gun Recoil

The growth gun recoil forces shall not exceed:

Recoil force during burst: +15,000 pounds
(Acting through elevation axis) -0 pounds

Counter recoil at end of burst: -8000 pounds

A

4.6 Controlled Internal Environments

The CIWS shall have the ability to control the temperature of the electronics housed internal to the system. The system

Environmental Control Group (ECG) provides minimum and maximum temperature control, condensation control and radar waveguide pressurization. The amount of temperature control depends on the location within the system. The ECG will control the air environment to the electronics within the electronics enclosure 100% of the time, except during periods of casualty and preventative maintenance. The electronics within the electronics enclosure shall be required to operate in the environments specified below and shall also survive the environment specified in paragraphs 2.1, 2.2, 2.3, and 2.4.

4.6.1 ECG Maximum Air Temperature Operate (Cooling Cycle). The maximum delivered air temperature from the ECG shall not exceed 46°C (114°F) dry bulb. The return air temperature to the ECG shall not exceed 62°C (144°F).

4.6.2 ECG Minimum Operating Air Temperature (Heating Cycle).

4.6.2.1 With the electronic equipment non-operating, the minimum delivered air temperature shall be maintained at -12 \pm 3°C (+10 \pm 5°F) in climatic conditions as low as -29°C (-20°F).

4.6.2.2 With the electronic equipment operating, the minimum delivered air temperature shall be maintained at 4° \pm 3°C (+40 \pm 5°F) in climatic conditions as low as -29°C (-20°F).

4.6.3 Waveguide Air Pressurization. Waveguide pressure shall be maintained by the ECG at 3.4 \pm 2.6 PSIG for a maximum input flow of 15.0 in³/min. The dew point of the conditioned air shall not exceed 15% relative humidity.

4.6.4 Air Humidity Operate. The humidity of the electronic enclosure interior shall be controlled such that there is no condensation.

4.6.5 ECG Air Pressurization. The conditioned air pressure to the electronics shall not be less than 1.5 inches water gage and the air flow into the electronics enclosure shall not be less than 640 cu. ft. min.

4.7 Controlled Transmitter and Power Supply Units Environment

The CIWS uses a liquid-to-liquid heat exchanger with a heater to control the radar transmitter environment. The transmitter shall operate with a maximum coolant (ethylene glycol) return temperature of +66°C (150°F). The transmitter shall transfer 40,600 British Thermal Units per hour (BTU/hr) (11.3 KW) maximum to the coolant. The coolant shall be supplied at 10.0 gallons per minute (gpm) and 130 PSIG. The coolant input temperature will be 46°C (+115°F).

4.8 Barbette and Mount Non-Controlled Internal Air Temperature

The equipment shall operate in non-controlled air environment that can reach a maximum of 66°C (+150°F), (the peak is caused by solar radiation and self-generated heat) and a minimum of -29°C (-20°F).

4.9 Radar Servo Structure Assembly Temperature Control

The minimum temperature is controlled in the radar servo assembly through the use of a heater/blower combination. The minimum operating temperature shall be maintained at 4°C (+40°F). Maximum radome internal air temperature shall not exceed 66°C (+150°F). The radar servo assembly heater shall be turned off when the internal temperature exceeds 38°C (100°F).

5.0 THREAT INDUCED ENVIRONMENT

5.1 Shock Loading

The equipment shall withstand shock loading induced by subsurface HE warhead detonation of Grade A, deck-mounted, Class II equipment in accordance with MIL-S-901C. The CIWS uses resilient mounts and the shock accelerations seen by the system will vary as specified in Table IV.

The near miss shock accelerations of Table IV are based on the method of NAVSHIPS 250-423-31. The vertical and lateral shock accelerations result from maximum velocity changes of 96 and 38 inches per second, respectively. Shock loads have been mitigated by shock isolators located between the deck and the electronic enclosure, the deck and the barbette equipment platform and the top of the barbette and the mount platform. The search and track antennas, enclosure drawers and the electronics are vibration isolated. DI-433-BE-40B defines the isolator characteristics and their rattle space requirements.

DI-444-A-003 defines the shock loads throughout the system for structural design.

6.0 COMBINATION LOADING

6.1 Combined Load Operating Capability

The CIWS shall operate normally for the combined operational loads for wind, ice, gun blast, ships motion, and gun recoil of paragraphs 2.6, 2.11, 3.2, 3.3.1 and 4.4, respectively.

6.2 Combined Survival Loading

The CIWS shall withstand the combined survival loads for ice, ships motion, and waves of paragraphs 2.11, 3.3.1 and 3.5, respectively.

| A

7.0 BENCH HANDLING

On the package level the equipment will be subjected to bench handling shocks as defined in MIL-STD-810C, Method 516.2, Procedure V and will operate normally after the applied shocks.

| A

8.0 TRANSPORTATION

Transportation of the CIWS and spares can take place in trucks, trains and aircraft for long durations. This transportation environment results in a maximum of 1.5 g peak vibration in all axes. Lifting equipment and lifting attach points shall be designed for 5 g loads.

Table 1
Ship Motion Characteristics for System Design
 (Reference: Table 3 of WS 13902D)

A) Ship Motion: Max amplitude (DE 1040)

	<u>Full Capability</u>		<u>Reduced Capability</u>		<u>Withstand and recover</u>	
	<u>Ampl.</u> (Deg)	<u>Period</u> (Sec)	<u>Ampl.</u> (Deg)	<u>Period</u> (Sec)	<u>Ampl.</u> (Deg)	<u>Period</u> (Sec)
Sinusoidal:						
Roll	+25	8.5	+35	8.5	+45	8.5
Pitch	+5	7	+8	7	+15	7
Yaw	+2.5	7	+4	7	+7.5	7

B) Ship motion: Max acceleration (LST 1156)

	<u>Full Capability</u>		<u>Reduced Capability</u>		<u>Withstand and recover</u>	
	<u>Ampl.</u> (Deg)	<u>Period</u> (Sec)	<u>Ampl.</u> (Deg)	<u>Period</u> (Sec)	<u>Ampl.</u> (Deg)	<u>Period</u> (Sec)
Sinusoidal:						
Roll	+20	6	+30	6	+45	6
Pitch	+5	4	+8	4	+15	4
Yaw	+2.5	4	+4	4	+7.5	4

The above LST ship motions can produce the following linear accelerations at a point 182 feet forward and 32 above the LST center of gravity.

	<u>Full Capability & Maintenance</u>	<u>Reduced Capability</u>	<u>Withstand and recover</u>
Vertical*	1.3 g	2.2 g	3.6 g
Athwartship	1.0 g	1.5 g	2.2 g
Longitudinal	.4 g	.7 g	1.6 g

* Gravity bias not included.

Table II
System Maximum Responses for MIL-STD-167B Test

Component	Input Axis	Response Curve*	Component	Input Axis	Response Curve*
Barbette, Top	X	1	Gun Muzzle	X	5
	Y	1		Y	5
	Z	4		Z	5
Train Platform	X	2	Gun Ball Joint	X	2
	Y	2		Y	2
	Z	2		Z	2
Mount, Bottom	X	2	Magazine, Front	X	2
	Y	2		Y	2
	Z	2		Z	2
Mount, Top	X	2	Barbette Platform, Edge	X	1
	Y	2		Y	1
	Z	2		Z	6
Track Radome, Bottom	X	3	Barbette Platform, Center	X	1
	Y	3		Y	1
	Z	3		Z	6
Lower and Upper Track Isolator Support	X	3	Electronics Encl, Top	X	4
	Y	3		Y	4
	Z	3		Z	4
Microwave Receiver, Track Antenna	X	3	Double RU, (Signal Processor)	X	4
	Y	3		Y	4
	Z	3		Z	4
Search Antenna, Base	X	3	Single RU, (Signal Generator)	X	4
	Y	3		Y	4
	Z	3		Z	4

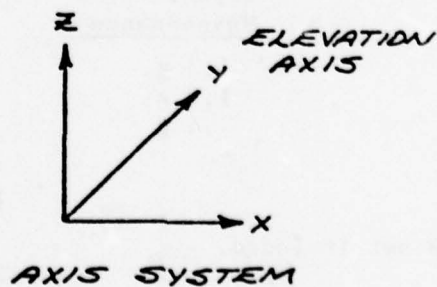

*Response curves are defined on next page.

TABLE II (CONT'D.)

MIL-STD-167B INDUCED SYSTEM RESPONSES

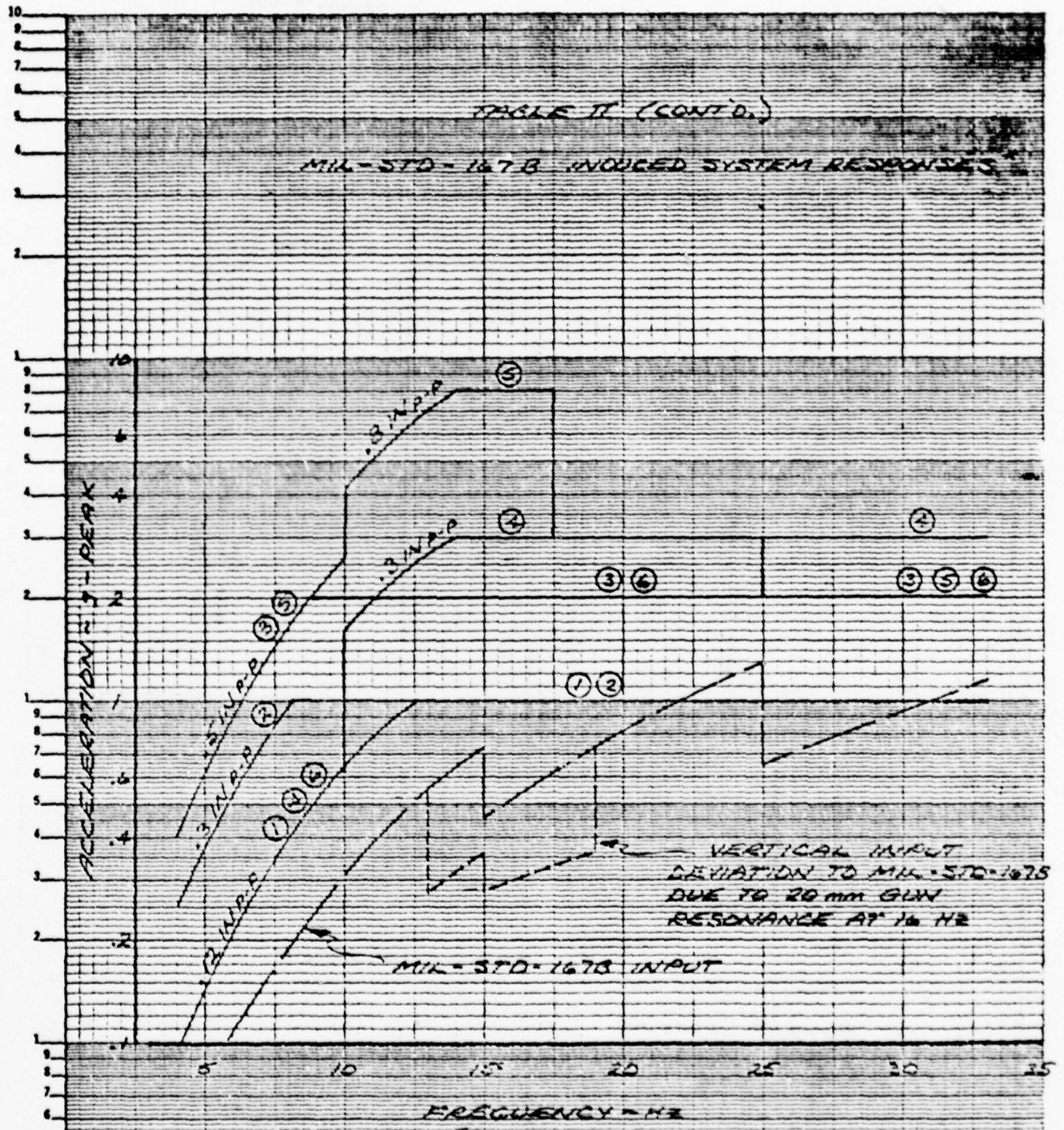

* BASED ON RESPONSES MEASURED ON PRGTC 2 DURING MIL-STD-167B TEST

Table III
30 mm Gun Blast Pressures for Structural Design

Structure	Firing Angle		Reflected Blast Pressure 30 mm (PSI)
	Elev. (Deg)	Train (Deg)	
Barbette Panel	0	0, \pm 90	3.0
	-25	0, \pm 90	8.0
	-25	\pm 45, \pm 135	18.0
	0	\pm 45, \pm 135	5.0
Electronics Encl.	0	\pm 120	5.0
	0	\pm 135	8.5
	0	\pm 165	11.0
	-25	\pm 120	11.0
Mount	0	*	2.5
	-25	*	8.0
Radar Servo Structure	*	*	1.9

*Does not vary with angle.

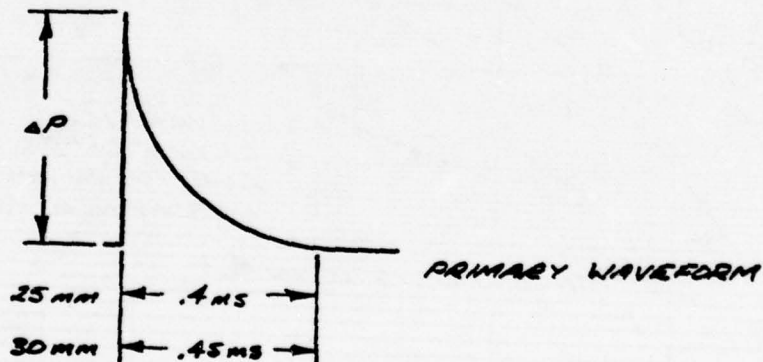

** Blast loads do not apply to the Local Control Panel or Remote Control Panel.

FIGURE 1

DI-444-A-002

ENVIRONMENTAL REQUIREMENT ALLOCATION MATRIX

	SHIPBOARD							CIWS									MISC.										
	3.2 GUN BLAST	3.3.1 SHIP MOTION	3.3.2 SHIP INCLINATION - OPERATE	3.3.3 SHIP INCLINATION - SURVIVE	3.3.4 SHIP TURNING RATE	3.4 SHIP VIBRATION	3.5 WAVE LOADING	3.6 SEA STATE	3.7 SHIP INTERNAL TEMPERATURE	4.1 ACOUSTIC NOISE	4.2.1 25mm GUN ACOUSTICS	4.2.2 30mm GUN ACOUSTICS	4.3 25mm GUN VIBRATION	4.4 MOUNT MOTION	4.5 GUN RECOIL	4.6.1 MAX. TEMP. - OPERATE	4.6.2 MIN. TEMP. - OPERATE	4.6.3 WAVEGUIDE RESSURIBATION	4.6.4 AIR HUMIDITY - OPERATE	4.6.5 AIR RESSURIBATION	4.7 TRANSMITTER TEMPERATURE - CONTROLLED	4.8 BARRETTE / MOUNT RADAR CONTROLLED TEMPERATURE	5.1 SHOCK LOADINGS	6.1 COMBINED LOAD - OPERATE	7.0 BENCH HANDLING	8.0 TRANSPORTATION	
	X	X	X		X	X	X	X																			
	X	X	X		X	X	X	X															X			X	X
	X	X	X		X	X	X	X															X			X	X
	X	X	X		X	X	X	X															X			X	X
	X	X	X		X	X	X	X															X			X	X
	X	X	X		X	X	X	X															X			X	X
	X	X	X		X	X	X	X															X			X	X
	X	X	X		X	X	X	X															X			X	X
	X	X	X		X	X	X	X															X			X	X
	X	X	X		X	X	X	X															X			X	X
	X	X	X		X	X	X	X															X			X	X
	X	X	X		X	X	X	X															X			X	X
	X	X	X		X	X	X	X															X			X	X
	X	X	X		X	X	X	X															X			X	X
	X	X	X		X	X	X	X															X			X	X

2

FIGURE 1
PILOTLINE CIWS ENVIRONMENTAL REQ

ITEM	CLIMATIC														SHIP											
	HARDMOUNTED	VIBRATION ISOLATED	2.1A THERMAL AIR LOW TEMP. - OPERATE	2.1B THERMAL AIR LOW TEMP. - SURVIVE	2.2A THERMAL AIR LOW TEMP. - OPERATE	2.2B THERMAL AIR LOW TEMP. - SURVIVE	2.3 THERMAL AIR HIGH TEMP. - OPERATE	2.3 THERMAL AIR HIGH TEMP. - SURVIVE	2.4 SOLAR RADIATION	2.5 HUMIDITY	2.5 SEA TEMPERATURE	2.6 WIND LOADING	2.7a BLOWING PARTICLES OPERATE	2.7b BLOWING PARTICLES SURVIVE	2.8 ATMOSPHERIC PRESSURE	2.9 RAIN	2.10 FUNGUS	2.11 ICE LOADING	2.12 SALT FOG	3.1 SHIPBOARD MAGNETIC	3.2 GUN BLAST	3.3.1 SHIP MOTION	3.3.2 SHIP INCLINATION-OPERATE	3.3.3 SHIP INCLINATION-SURVIVE	3.3.4 SHIP MOTION	
31 TRAIN PLATFORM																										
32 STRUCTURE PLATFORM		X	X	X	X	X	X	X		X	X	X		X	X	X	X	X	X	X	X	X	X	X	X	X
33 ISOLATORS, SHOCK	X		X	X	X	X	X	X		X	X	X		X	X	X	X	X	X	X	X	X	X	X	X	X
34 BARBETTE																										
35 STRUCTURE, FRAME	X		X	X	X	X	X	X		X	X	X		X	X	X	X	X	X	X	X	X	X	X	X	X
36 STRUCTURE, EQUIP. PLATFORM		X	X	X	X		X							X		X	X		X	X	X	X	X	X	X	X
37 POWER SUPPLY, HYD.		X		X		X		X					X		X		X	X		X	X	X	X	X	X	X
38 CONTROL GROUP, ENVIRONMENT		X		X		X		X	X				X		X		X	X		X	X	X	X	X	X	X
39 SWITCHING MODULE		X		X		X		X					X		X		X	X		X	X	X	X	X	X	X
40 TRANSFORMER ASSY.		X		X		X		X					X		X		X	X		X	X	X	X	X	X	X
41 TRANSMITTER ASSY.		X		X		X		X					X		X		X	X		X	X	X	X	X	X	X
42 KLYSTRON		X		X		X		X					X		X		X	X		X	X	X	X	X	X	X
43 RATE SWITCH		X		X	X	X		X					X		X		X	X		X	X	X	X	X	X	X
44 ISOLATORS, SHOCK		X		X	X	X		X							X		X	X		X	X	X	X	X	X	X
45 ELECTRONICS ENCLOSURE																										
46 STRUCTURE ENCLOSURE		X		X	X	X	X	X		X	X	X		X	X	X	X	X	X	X	X	X	X	X	X	X
47 ISOLATORS, SHOCK		X		X	X	X	X	X		X	X	X		X	X	X	X	X	X	X	X	X	X	X	X	X
48 ISOLATORS, VIBRATION		X		X		X		X							X		X	X		X	X	X	X	X	X	X
49 SLIDES, DRAWER		X		X		X		X							X		X	X		X	X	X	X	X	X	X
50 EXCHANGER, HEAT		X		X	X	X	X	X	X	X	X	X	X	X	X	X	X	X	X	X	X	X	X	X	X	X
51 POWER SUPPLY, CONTROL GP		X		X		X		X					X		X		X	X		X	X	X	X	X	X	X
52 RU'S		X		X		X		X					X		X		X	X		X	X	X	X	X	X	X

URE 1 (CONT'D.)

NTAL REQUIREMENT ALLOCATION MATRIX

SHIPBOARD				CIWS										MISC.													
3.1 SHIP MOTION	3.2 SHIP INCLINATION - OPERATE	3.3 SHIP INCLINATION - SURVIVE	3.4 SHIP TURNING RATE	3.5 SHIP VIBRATION	3.6 WAVE LOADING	3.7 SEA STATE	4.1 SHIP INTERNAL TEMPERATURE	4.2.1 ACOUSTIC NOISE	4.2.2 25 MM GUN ACOUSTICS	4.3 30 MM GUN ACOUSTICS	4.4 25 MM GUN VIBRATION	4.5 MOUNT MOTION	4.6.1 GUN RECOIL	4.6.2 MAX. TEMP. - OPERATE	4.6.3 MIN. TEMP. - OPERATE	4.6.4 WAVEGUIDE PRESSURIZATION	4.6.5 AIR HUMIDITY - OPERATE	4.7 TRANSMITTER RESSURIZATION	4.8 BARBETTE & MOUNT MAN-CONTROLLED TEMP.	4.9 RADAR CONTROLLED TEMP.	5.1 SHOCK CONTROLLED TEMPERATURE	6.1 SHOCK LOADING	6.1 COMBINED LOAD - OPERATE	7.0 COMBINED LOAD - SURVIVE	8.0 BENCH HANDLING	8.0 REINTEGRATION	
			X																								
X	X			X	X		X		X		X	X										X	X	X			
X	X			X	X		X		X		X	X										X	X	X			
			X																								
X	X			X	X		X		X		X	X										X	X	X			
X	X			X	X		X		X		X	X										X	X	X			
X	X			X	X		X		X		X	X										X	X	X			
X	X			X	X		X		X		X	X										X	X	X			
X	X			X	X		X		X		X	X										X	X	X			
X	X			X	X		X		X		X	X										X	X	X			
X	X			X	X		X		X		X	X										X	X	X			
X	X			X	X		X		X		X	X										X	X	X			
X	X			X	X		X		X		X	X										X	X	X			
X	X			X	X		X		X		X	X										X	X	X			
X	X			X	X		X		X		X	X										X	X	X			
X	X			X	X		X		X		X	X										X	X	X			
X	X			X	X		X		X		X	X										X	X	X			
X	X			X	X		X		X		X	X										X	X	X			
X	X			X	X		X		X		X	X										X	X	X			
X	X			X	X		X		X		X	X										X	X	X			
X	X			X	X		X		X		X	X										X	X	X			
X	X			X	X		X		X		X	X										X	X	X			
X	X			X	X		X		X		X	X										X	X	X			
X	X			X	X		X		X		X	X										X	X	X			
X	X			X	X		X		X		X	X										X	X	X			
X	X			X	X		X		X		X	X										X	X	X			
X	X			X	X		X		X		X	X										X	X	X			
X	X			X	X		X		X		X	X										X	X	X			
X	X			X	X		X		X		X	X										X	X	X			
X	X			X	X		X		X		X	X										X	X	X			
X	X			X	X		X		X		X	X										X	X	X			
X	X			X	X		X		X		X	X										X	X	X			
X	X			X	X		X		X		X	X										X	X	X			
X	X			X	X		X		X		X	X										X	X	X			
X	X			X	X		X		X		X	X										X	X	X			
X	X			X	X		X		X		X	X										X	X	X			
X	X			X	X		X		X		X	X										X	X	X			
X	X			X	X		X		X		X	X										X	X	X			
X	X			X	X		X		X		X	X										X	X	X			
X	X			X	X		X		X		X	X										X	X	X			
X	X			X	X		X		X		X	X										X	X	X			
X	X			X	X		X		X		X	X										X	X	X			
X	X			X	X		X		X		X	X										X	X	X			
X	X			X	X		X		X		X	X										X	X	X			
X	X			X	X		X		X		X	X										X	X	X			
X	X			X	X		X		X		X	X										X	X	X			
X	X			X	X		X		X		X	X										X	X	X			
X	X			X	X		X		X		X	X										X	X	X			
X	X			X	X		X		X		X	X										X	X	X			
X	X			X	X		X		X		X	X										X	X	X			
X	X			X	X		X		X		X	X										X	X	X			
X	X			X	X		X		X		X	X										X	X	X			
X	X			X	X		X		X		X	X										X	X	X			
X	X			X	X		X		X		X	X										X	X	X			
X	X			X	X		X		X		X	X										X	X	X			
X	X			X	X		X		X		X	X										X	X	X			
X	X			X	X		X		X		X	X										X	X	X			
X	X			X	X		X		X		X	X										X	X	X			
X	X			X	X		X		X		X	X										X	X	X			
X	X			X	X		X		X		X	X										X	X	X			
X	X			X	X		X		X		X	X										X	X	X			
X	X			X	X		X		X		X	X										X	X	X			
X	X			X	X		X		X		X	X										X	X	X			
X	X			X	X		X		X		X	X										X	X	X			
X	X			X	X		X		X		X	X										X	X	X			
X	X			X	X		X		X		X	X										X	X	X			
X	X			X	X		X		X		X	X										X	X	X			
X	X			X	X		X		X		X	X										X	X	X			
X	X			X	X		X		X		X	X										X	X	X			
X	X			X	X		X		X		X	X										X	X	X			
X	X			X	X		X		X		X	X										X	X	X			
X	X			X	X		X		X		X	X										X	X	X			
X	X			X	X		X		X		X	X										X	X	X			
X	X			X	X		X		X		X	X										X	X	X			
X	X			X	X		X	</																			

FIGURE 2

INTERNAL ACOUSTIC ENVIRONMENT
DUE TO 25mm GUN

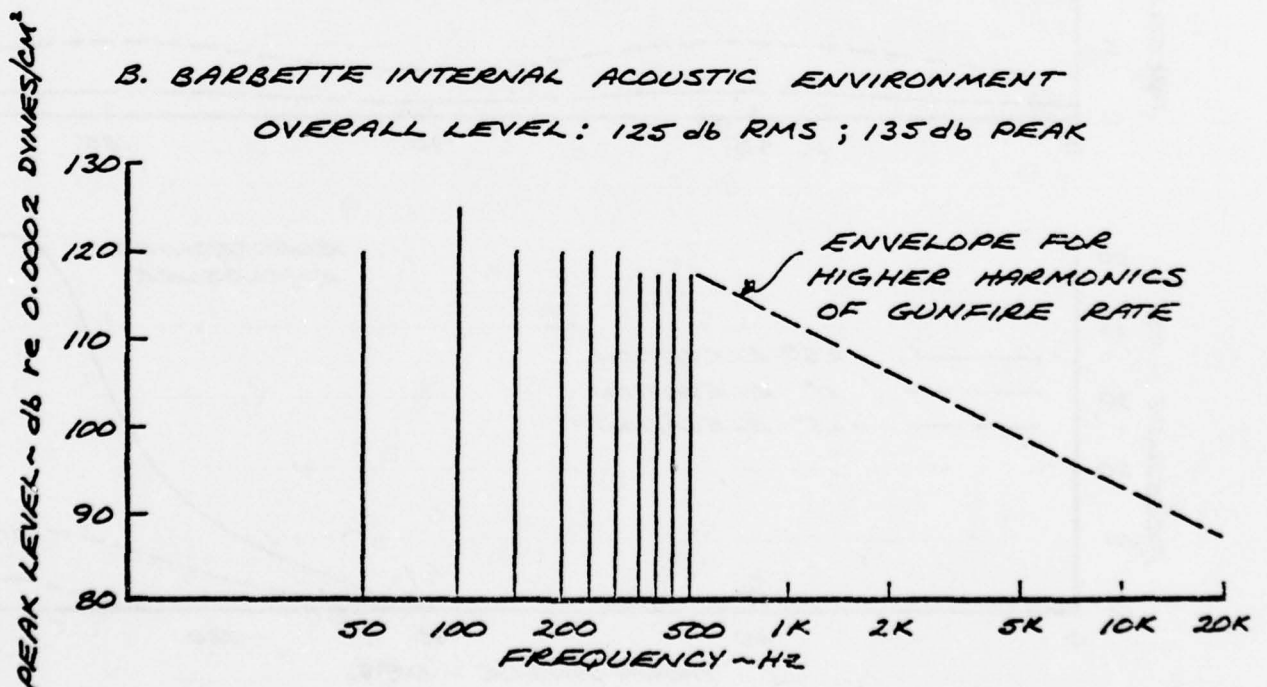
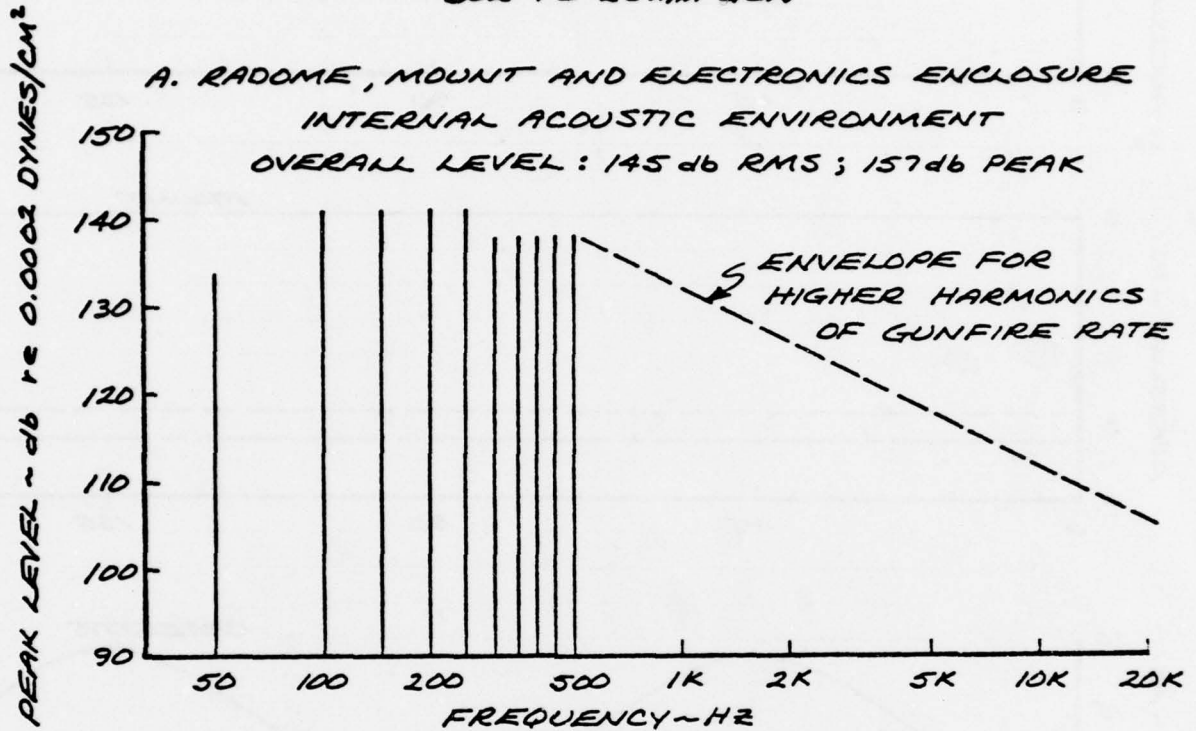

FIGURE 3
REFLECTED 30mm GUN BLAST PRESSURE
GAU - B , TP ROUND

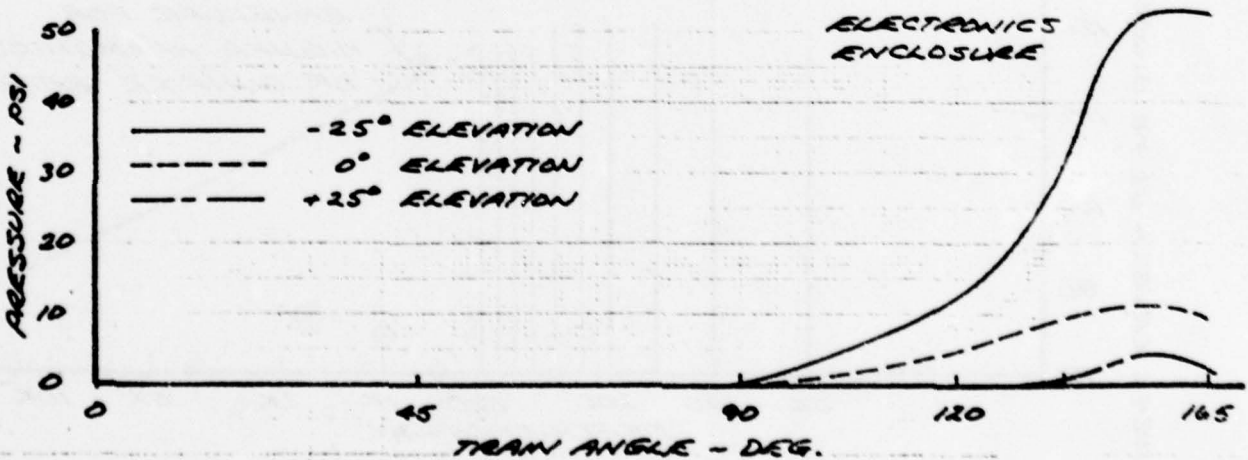
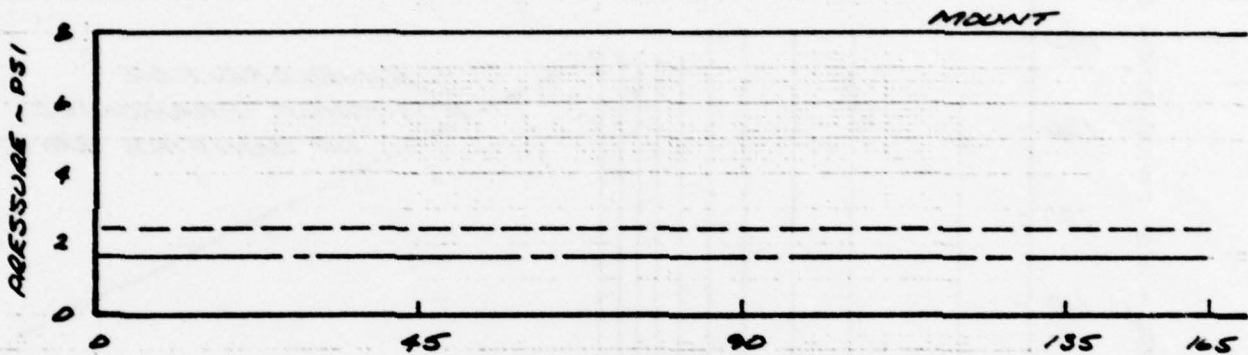
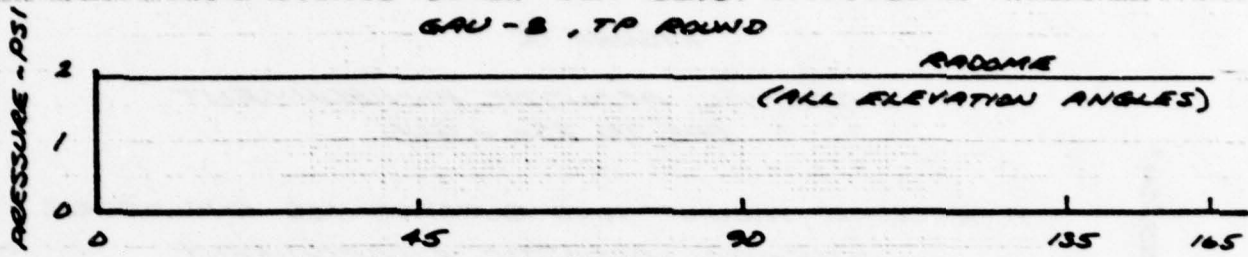

FIGURE 4

ACOUSTIC ENVIRONMENT INPUT FOR STRUCTURE FATIGUE ANALYSIS

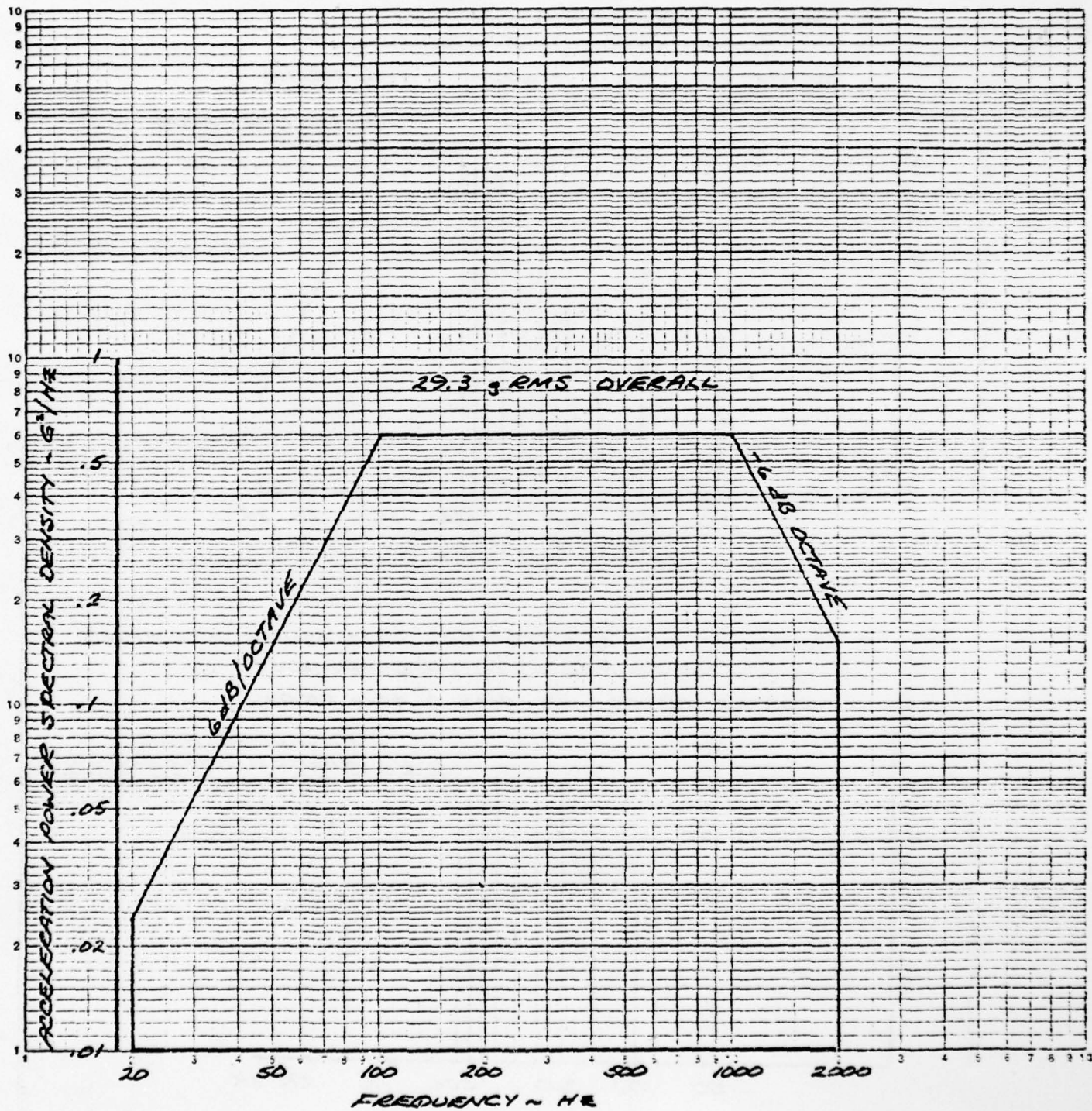
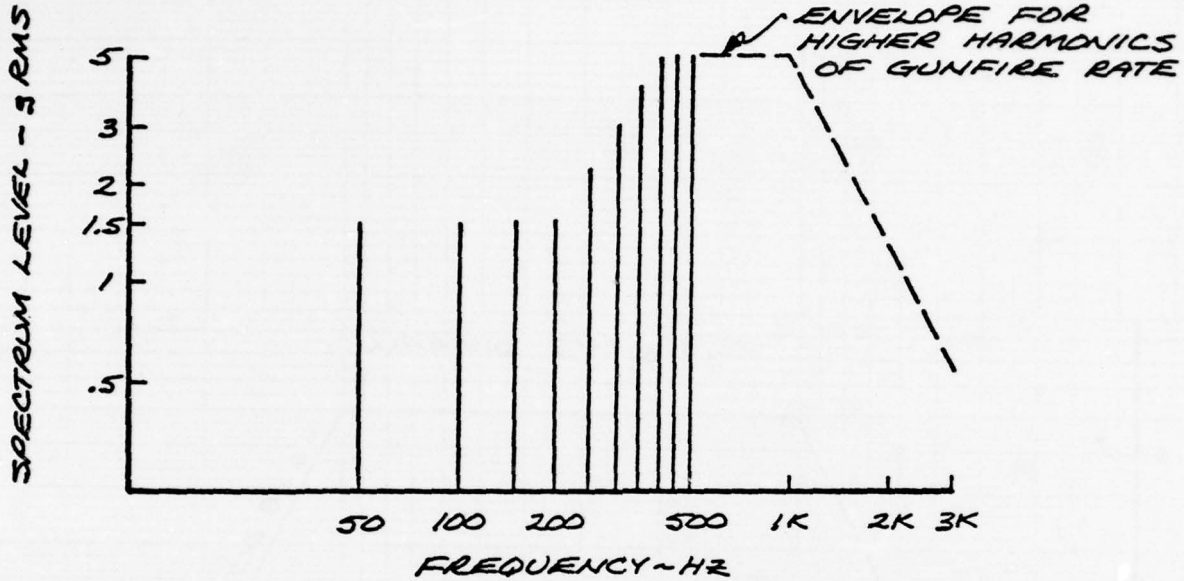

FIGURE 5

25mm GUN INDUCED ENVIRONMENTS

A. MOUNT INTERIOR VIBRATION
(NON-PROTECTED EQUIPMENT)

OVERALL LEVEL: 15g RMS; 50g PEAK

B. RADOME AND ELECTRONICS ENCLOSURE INTERIORS
(NON-PROTECTED EQUIPMENT)

OVERALL LEVEL: 12g RMS; 40g PEAK

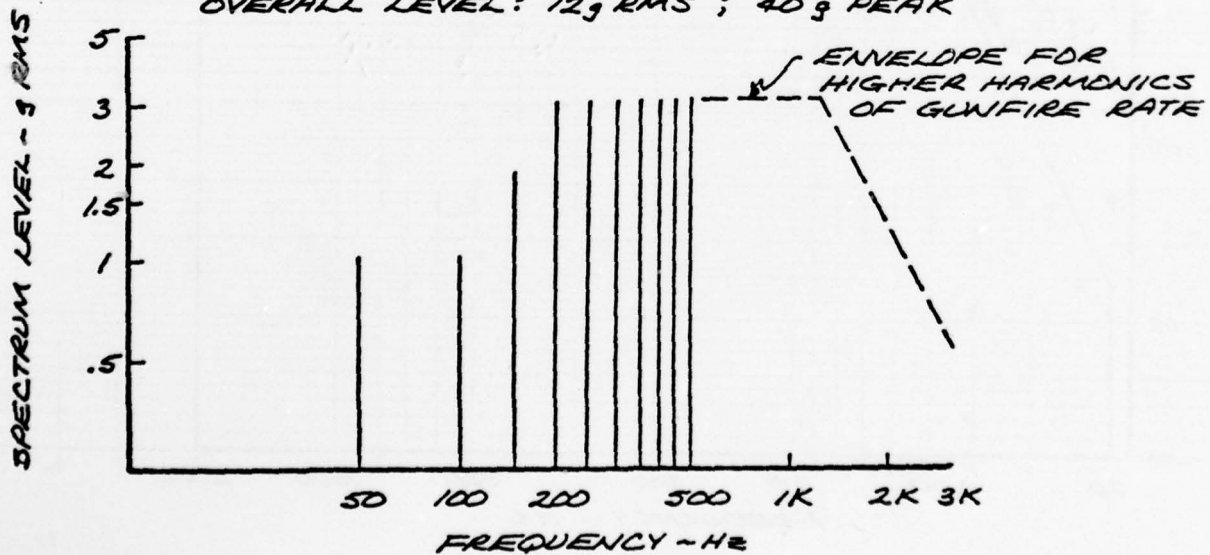

FIGURES (CONT.)

25mm GUN INDUCED ENVIRONMENTS

C. ISOLATED PACKAGES IN RADOME (25Hz ISOLATION)
 OVERALL LEVEL: 2g RMS; 7g PEAK

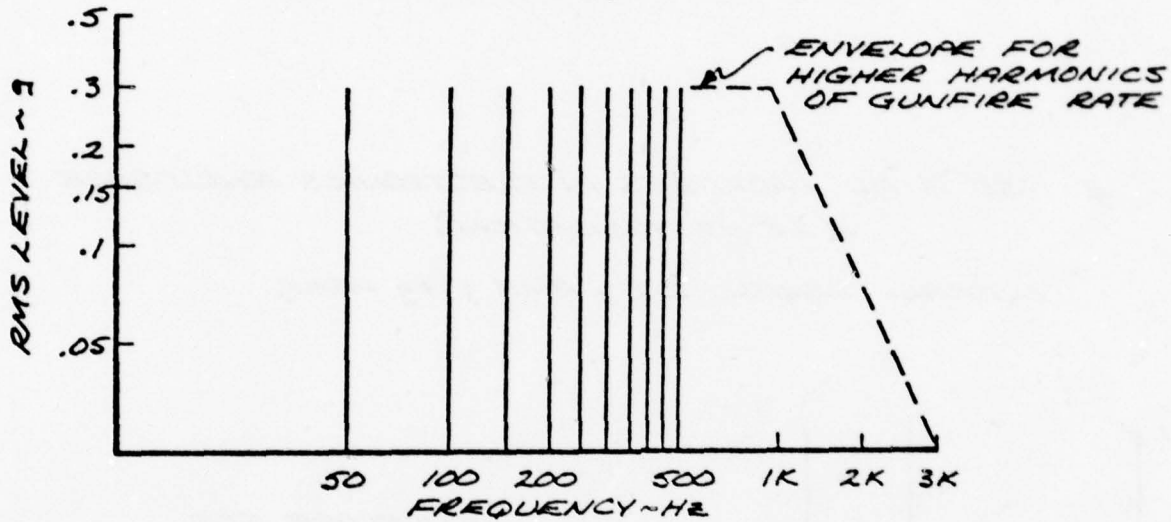

D. BARBETTE EQUIPMENT PLATFORM VIBRATION (10 Hz ISOLATION)
 OVERALL LEVEL: 1g RMS; 3.5g PEAK

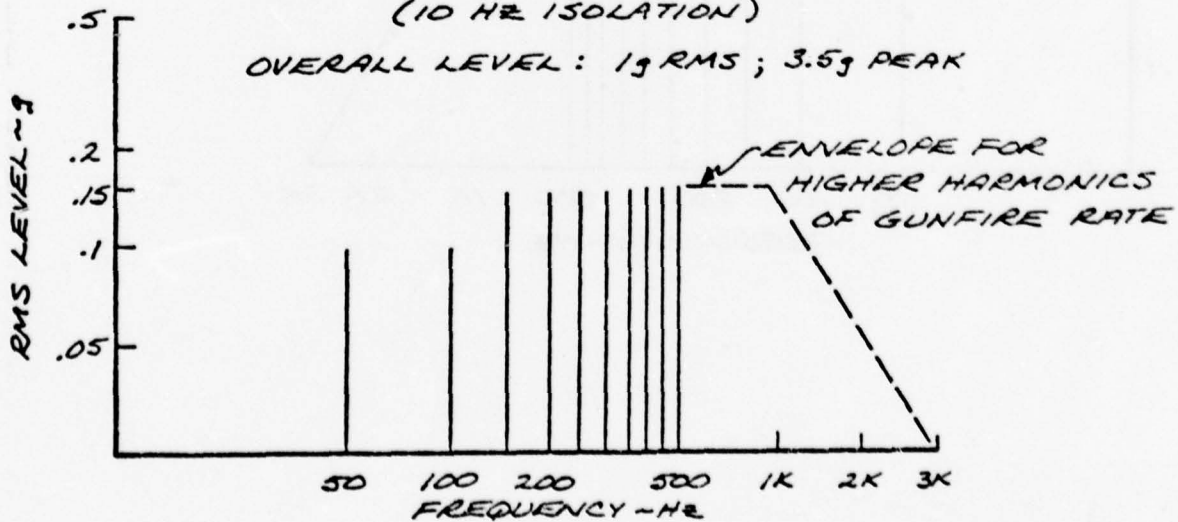
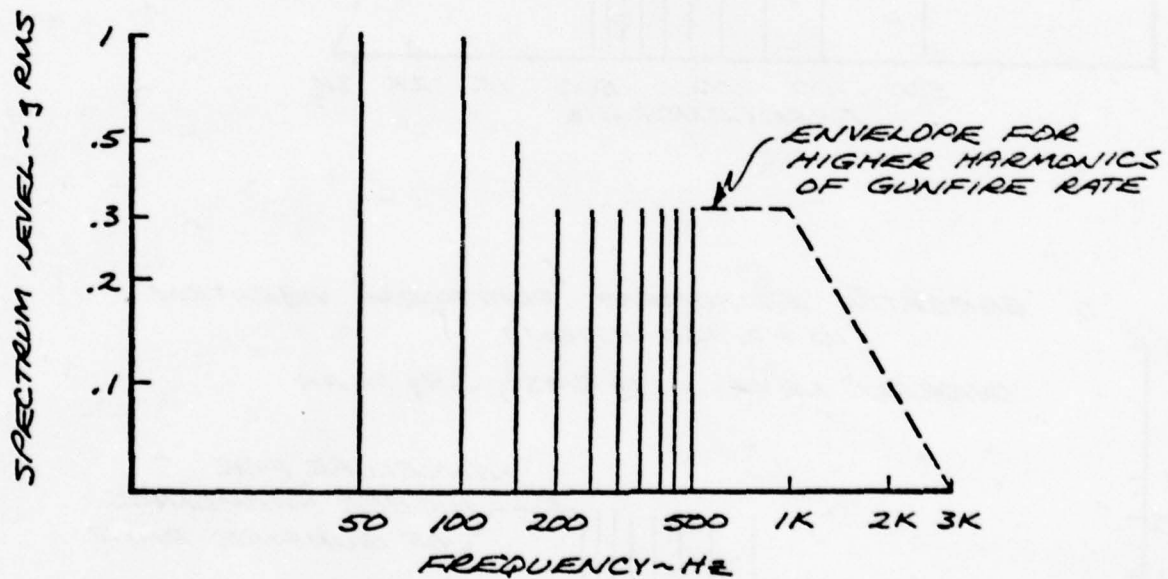

FIGURE 5 (CONT.)

25 mm GUN INDUCED ENVIRONMENTS

E. ISOLATED PACKAGES IN ELECTRONICS ENCLOSURE
(25 Hz ISOLATION)

OVERALL LEVEL: 2.2 g RMS ; 7g PEAK



Appendix A
ENVIRONMENTAL TEST CONDITIONS AND TEST METHODS

Environmental qualification of hardware is to be performed using military standard tests for all critical items. At the subsystem and system level some special tests are required in addition to the military standard tests. Tables A-I and A-II provide a list of the test methods to be used in critical item and subsystem specifications for environmental qualification for the non-operating and operating conditions.

Table A-III provides the test conditions and test methods for performing shock, vibration and acoustic testing. The test conditions take into account the dynamic environments from all sources. Test conditions depend on equipment location and on the presence or absence of vibration isolators. Table A-III indicates the appropriate levels according to this criteria.

Table A-IV provides a summary of the design temperatures throughout the system.

A

Table A-1
NON-OPERATING ENVIRONMENTAL TEST METHODS PER MIL-STD-810C

Environment	DI-444-A-002 Reference	Critical Item	Test Method		Notes
			Subsystem	System	
Low Temp	2.1 b	503.1	502.1	502.1	Min. Temp = -40°C
High Temp	2.2 b		DI Duty Cycle	DI Duty Cycle	Max Temp = 71°C
Humidity	2.4	507.1, Proc. IV	507.1	—	
Blowing Particles	2.7 b	510.1	510.1	—	
Atmospheric Pressure	2.8	500.1	—	—	Min Pressure 1.68 psi Operation not required at low pressure Max Rate = 7 IN/HR
Rain	2.9	—	—	*	
Fungus	2.10	508.1**	508.1**	—	
Salt Fog	2.12	509.1	509.1	—	Enclosures: 5% for 200 HR Interior: 5% for 48 HR***
Combined Survival Loads	6.2	*	*	*	Loading per: 2.6, 2.11, 3.3, 3.5 of DI-44-A-002
Bench Handling	7.0	516.2, Proc. V	—	—	
Transportation	8.0	5.4.2, Proc. X	—	—	Gun vibration qualifies for transportation also

* Special Test Plan Required.

** Test only when materials do not meet the requirements of MIL-STD-454 and when directed by Program Office.

*** No test required when item is housed by 2 or more enclosures.

51444-A-002

Table A-II
OPERATING ENVIRONMENTAL TEST METHODS

Environment	I-444-A-002 Reference	Test Method			Notes
		Critical Item	Subsystem	System	
Low Temp	2.1 a	502.1	502.1	502.1	MIL-STD-810C Omit Steps 2 & 3
High Temp	2.2 a	501.1, Proc.I	501.1, Proc. I	DI Duty Cycle	Omit Steps 2 & 3
Solar Radiation	2.3	—	—	—	
Sea Temp	2.5	—	*	*	
Rain	2.9	—	—	*	
Magnetic Conditions	3.1	—	—	*	
Gun Blast	3.2	—	—	*	
Ship Motion	3.3	—	—	*	
Ship Vibration	3.4	—	MIL-STD-167B	MIL-STD-167B	
Acoustic Noise	4.1	MIL-STD-740	MIL-STD-740	MIL-STD-740	
Gun Acoustics	4.2	Method 515.2	Method 515.2	Method 515.2	MIL-STD-810C Max level per DI-444-A-002
Gun Vibration	4.3	Method 514.2	Method 514.2	Method 514.2	MIL-STD-810C Max level per DI-444-A-002
Mount Motion	4.4	—	*	*	
Shock Loading	5.2	MIL-STD-810C Method 516.2	MIL-STD-810C Method 516.2	MIL-STD-901C	Max level per DI-444-A-002
Combined Loading	6.1	*	*	*	Loads per 2.6, 2.11, 3.3, 4.5

*Special Test Plan Required

Table A-III
SHOCK, VIBRATION AND ACOUSTIC TEST CONDITIONS FOR CWS PACKAGE

Environment and Method	Package Location and Type of Mounting					
	Radome	Mount or Platform	Barbette	Elect. Enclosure	Local & Remote Control Panels	
Shock	25 Hz (1) Isolated	Non Protected	(10 Hz (1) Isolation)	25 Hz (1), Isolated	Non Protected	Isolated
MIL-STD-810C Method 516.2	Procedure I 40g Half-Sine 11 m-Sec	Procedure IV 100g Sawtooth 6 m-Sec	Procedure III 30g Half-Sine 11 m-Sec	Procedure I 40g Half-Sine 11 m-Sec	Procedure IV 100g Sawtooth 6 m-Sec	Procedure I 40g Half-Sine 11 m-Sec
Vibration	Procedure VII Condition N (2g Peak) Condition AE (5.4g RMS)	Procedure V Condition P (5g Peak) Condition AJ (16.9g RMS)	Procedure VII Condition N (2g Peak) Condition AK (5.4g RMS)	Procedure VII Condition N (2g Peak) Condition AE (5.4g RMS)	Procedure V Condition P (5g Peak) Condition AJ (16.9g RMS)	Procedure VII Condition M (2g Peak) Condition AE (5.4g RMS)
Acoustic	(3)	Category C	Category B	Category B	Category C	Category A
MIL-STD-810C Method 515.2 Procedure I	(145 db (2), 30 min.)	(160 db (2), 8 min.)	(150 db (2), 30 min.)	(150 db (2), 30 min.)	(160 db (2), 8 min.)	140 db (2), 30 min.

- Environment applicable at package side of isolator. Use test condition in first column if the normally isolated package is tested without isolators. The input to the isolators is the non protected environment of the second column.
- Reference 0.0002 dynes/cm².
- 130 db inside receiver housing.

B. NON-OPERATING:

ENVIRONMENT	TEST CONDITION (1)
Shock (bench handling)	MIL-STD-810C, Method 516.2, Procedure V (edge lifted 4 inches and dropped on wooden bench top for total of 24 drops)
Vibration (Transportation)	MIL-STD-810C Method 514.2 Procedure X, Curve AH(1.5g) or .3 in P-P. (Resonance dwell and sinusoidal cycling for a total test time of 1 hour per axis)

- The non-operating test condition does not depend on location within the system.
- Transportation not required when operating vibration (gun vibration) test is performed.

Table A-IV
TEMPERATURE ENVIRONMENTS FOR CIMS PACKAGES

OPERATION	TEST METHOD (MIL-STD-810C)	PACKAGE LOCATION					
		RADAR SERVO STRUCTURE	MOUNT AND PLATFORM	UNCONTROLLED	TRANSMITTER & POWER SUPPLY	ELECTRONICS ENCLOSURE	LOCAL & REMOTE CONTROL PANELS
Non-Operating	503.1 Duration: 3 cycles of 4 hrs. each or until stabilized.	-40 to 71°C (-40 to 160°F)	-40 to 71°C (-40 to 160°F)	-40 to 71°C (40 to 160°F)	-40 to 71°C (-40 to 160°F)	-40 to 71°C (-40 to 160°F)	-40 to 71°C (-40 to 160°F)
Operating							
LOW	502.1 (Omit Steps 2 & 3) Duration: Until temp. is stabilized.	4°C (39°F)	-29°C (-20°F)	-29°C (-20°F)	46°C (115°F)	4°C (39°F)	0°C (32°F)
HIGH	501.1, Procedure I (Omit Steps 2 & 3) Duration: Until temp. is stabilized	66°C (150°F)	66°C (150°F)	66°C (150°F)	66°C (150°F)	62°C (144°F)	50°C (122°F)

CDRL A003
Code Ident 9243
M-24-6-678

APPENDIX P

DEVELOPMENT PROCESS SPECIFICATION (D.P.S.) SEARCH RADOME

1.0 SCOPE AND PURPOSE

This Procedure defines a process for the fabrication and tooling requirements of the hemispherical search radome 5188237, using glass reinforced polyester resin, and polyurethane foam.

2.0 PROCEDURE

Note A: Resin and catalyst mix for the fabrication of Search Radome (when applying resin by brush) must be taken from the appropriate preset resin and catalyst dispensers.

Note B: Gel coat and catalyst mix (in applying white gel coat by brush) must be taken from the appropriate preset gel coat and catalyst dispensers.

Note C: Pot life of resin/catalyst mix is approximately 25 minutes at 25°C (77°F).

2.1 Fabrication of Facing Skins

2.1.1 Inner and Outer Radome Facings

2.1.1.1 Wax and polish both inner and outer molds.

2.1.1.2 Gel coat both molds .010 - .015 thick. Avoid puddling the white gel coat at bottom of concave outer mold.

2.1.1.3 Allow to cure 3 hours, minimum.

2.1.1.4 Lay-up one layer of 4 oz. glass cloth and resin over inner and outer molds. See drawing for lay-up pattern.

2.1.1.5 Use brushed in resin sparingly. Squeegee out excess resin.

2.1.1.6 Apply a second layer of 4 oz. glass cloth and resin as in step 2.1.1.4. See drawing for overlap of seams.

SIZE	CODE IDENT NO.	DRAWING NUMBER
A	53711	5262550
SCALE NONE	REV LTR	SHEET 2

- 2.1.1.7 Use brushed in resin sparingly. Squeegee out excess resin.
- 2.1.1.8 After 75% cure of facings trim edges of molds free of glass cloth with box knife.
- 2.1.1.9 Cure facings for 2 hours at 140°F $\pm 10^\circ$ or for 48 hours at room temperature.
- 2.1.1.10 Carefully insert a thin putty blade between outer facing and outer mold and run putty knife around the periphery of the outer mold. Insert depth of blade need only be .25.
- 2.1.1.11 Through exterior of outer mold, drill 18 .125 diameter holes through outer facing, using holes already provided in the mold as template.
- 2.1.1.12 Thoroughly sand inner and outer facings with #60 grit sandpaper. Wipe facings with chlorothene soaked towels.
- 2.1.1.13 With .125 diameter dowel pins (18) locate 14 teflon spacers around periphery of outer mold. Ensure pins are flush with teflon spacers and do not protrude into foaming cavity. See drawing for teflon spacer placement.
- 2.1.1.14 Attach steel ring to flat surface of inner mold. Locate and restrain with 6 1/2-13 nuts and washers.

2.2 Foam Sandwich Encapsulation

- 2.2.1 Heat inner and outer molds, containing the inner and outer facings, for 1 hour at 32° $\pm 5^\circ$ C (80°-0, +10°F) to remove room temperature chill.
- 2.2.2 Attach inner mold, containing inner facing, to the hoist provided, attaching hook of hoist chain to eye centered in the inner mold, see drawing for assembly procedure.
- 2.2.3 Adjust height of inner mold to that required for ease of pouring foam using hoist.
- 2.2.4 Center outer mold, containing outer facing, below inner mold using guide pins. Lock caster wheels of outer mold in place.
- 2.2.5 Into 2 containers provided, pour an equal weight of No. 6502 foam: 3 lbs of component 1 in one container and 3 lbs of component 2 in the other container.

SIZE	CODE IDENT NO.	DRAWING NUMBER	
A	53711	5262550	
SCALE	NONE	REV LTR	SHEET 3

DI FORM 8 5254 #2

2.2.6 Pour container containing component 1 into container containing component 2.

2.2.7 Mix thoroughly both components with a pressurized air motor attached to a Jiffy Mixer, Model PS 21, for 15 +5 -0 seconds.

Caution: Time of mix is extremely important. Do not allow foaming action to begin in mixer container. Immediately pour foam into the bottom of the concave outer mold, and over the inner surface of outer facing.

2.2.8 Immediately lower inner mold attached to hoist into the cavity of the outer mold until steel ring in inner mold engages outer mold periphery.

2.2.9 With clamps attached to outer mold immediately lock both molds together.

Note D: Steps 2.2.6 through 2.2.9 must be accomplished within a time frame of 60 seconds.

Note E: Vent holes provided in aluminum ring will remove approximately 2-1/3 lbs of foam, the remainder being left in the mixing containers.

Note F: 6 lbs of foam must be mixed in mixer container to provide the proper foaming pressure to fill the radome hemisphere.

2.2.10 After 30 minute room temperature cure and after removal of foam flash, place mold assembly into oven and cure for 4 hours minimum at $71^{\circ}\text{C} \pm 5^{\circ}\text{C}$ ($160^{\circ}\text{F} \pm 10^{\circ}\text{F}$)

2.3 Hemisphere Removal From Molds

Caution: Mold assembly must be at room temperature ($77^{\circ} \pm 10^{\circ}\text{F}$) before removal of hemisphere.

2.3.1 Release clamps and remove steel ring from inner mold after disconnecting hoist clamp to inner mold.

2.3.2 Remove 18 dowel pins from exterior mold.

2.3.3 Reconnect hoist hook to inner mold and hoist inner and outer molds 3 to 6 inches above floor.

SIZE	CODE IDENT NO.	DRAWING NUMBER
A	53711	5262550
SCALE NONE	REV LTR	SHEET 4

- ↓
- 2.3.4 Between outer mold and outer facing of hemisphere insert a thin putty blade and place air hose nozzle (80 psi) and concentrate air jet at this location.
- 2.3.5 As the inner mold containing the foam/fiberglass hemisphere appears from the outer mold continue to apply air pressure around periphery of outer mold and at the same time applying tension to the hoist and a downward force to the outer mold.
- 2.3.6 After inner mold and radome have been removed from outer mold insert a thin putty knife between inner mold and inner facing of radome and run putty blade around periphery of the mold.
- 2.3.7 Place air hose nozzle at the parting line between radome and mold and apply air pressure (80 psi) to remove radome from inner mold.
- 2.3.8 Drill 18 .125 diameter holes through inner facing by using tooling holes provided in the exterior facing and teflon spacer.
- 2.3.9 Carefully remove the 14 teflon spacers, and any excess foam from around spacers.

Caution: Do not cut or rupture facings during step 2.3.9.

- 2.3.10 Place a piece of tape over each of the 18 tooling holes provided in the outer facing of the radome.

2.4 Fabrication of Hard Points in Search Radome Hemisphere

Prepare the following mixture to be used in casting the mounting bosses for the hard points in the radome.

100 grams of catalyzed polyester resin
50 grams of milled fibers

Mix thoroughly in quart container.

SIZE	CODE IDENT NO.	DRAWING NUMBER	
A	53711	5262550	
SCALE	NONE	REV LTR	SHEET 5



2.4.1 Carefully pour the resin/fibre mix into the 14 cavities provided around the periphery of the radome, filling flush + to the foam/facing surface.

Caution: Air voiding should be accomplished by pouring resin/fibre mix into one corner of the cavity and allowing the mix, as it fills the cavity, to void the air from the cavity.

Note G: Air gun and Semco cartridge may be used for filling boss cavities with resin/fibre mix.

2.4.2 Allow to cure at room temperature for a minimum of 3 hours.

2.4.3 Remove any wax residue with chlorothene O-T-620 1.25 up from base of hemisphere on inner surface of radome.

2.4.4 To inside of radome, using a brush coat of polyester resin applied to both bonding surfaces, bond a strip of cured gel coated fiberglass, 1.25 wide to inside surface of the radome flush with the base and with the gel coated surface exposed.

Allow to set-up 30 minutes before proceeding with step 2.4.5.

NOTE H: 1.25 wide strip of gel coated fiberglass shall consist of a double layer of 4 oz. glass cloth impregnated with polyester resin under a white gel coat surface with a nominal thickness of .010.

2.4.5 Any scratches or cuts in gel coat during removal of bosses can be touched-up with white gel coat and buffed.

2.4.6 Remove tape from periphery of radome, and redrill holes to a diameter of $.219 +.005 - .002$ with a countersink of $82^\circ \times .390$ dia on inner facing of radome. See drawing for dimensions and countersink locations.

2.4.7 Chamfer edge of base of radome. See drawing for dimensions.

SIZE A	CODE IDENT NO. 53711	DRAWING NUMBER 5262550
SCALE NONE	REV LTR	SHEET 6

2.5 Sealing The Base of The Radome

2.5.1 Mix 32 grams of B component and 8 grams of A component of PRC 1660L polyurethane elastomer.

2.5.2 Evacuate in bell jar for 3 minutes at 28 In. Hg.

2.5.3 Using a No. 6 artist's brush, coat a thin layer of elastomer over exposed edges of foam and also over the cured resin/fibre bosses.

2.5.4 Allow to cure undisturbed for 4 hours.

3. QUALITY ASSURANCE PROVISIONS

When surveillance of the process defined in this procedure, or inspection of the product indicates that the stipulations of this procedure have not been complied with, acceptance shall be withheld until Operations and Quality Assurance Departments concur that the engineering and reliability requirements have not been compromised.

4. SAFETY

Comply with all Pomona Division and OSHA Safety precautions required for use with flammable materials fabrication.

SIZE	CODE IDENT NO.	DRAWING NUMBER
A	53711	5262550
SCALE NONE	REV LTR	SHEET 7

CDRL A003
Code Ident 9243
M-24-6-678

APPENDIX Q

RADOME FORMAL DRAWINGS AND FABRICATION SKETCHES

8

7

6

5

4

NOTES:

1. TORQUE REQUIREMENTS :

1.1 APPLY 20-27 IN LBS TORQUE TO FINO NO. 4.

1.2 APPLY 11-16 IN LBS TORQUE TO FINO NO. 5.

2. AFTER ASSEMBLY, TOUCH UP ALL VISIBLE SURFACES OF FINO NO. 3 THRU 7 WITH ONE COAT OF FINO NO. 8 FOLLOWED BY 2 COATS OF FINO NO. 9.

3. FOR TEST PARAMETERS SEE DRAWING 5186581.

4. IDENTIFY WITH CODE IDENT. PART NO. AND REVISION LETTER IAW MIL-STD-130. LOCATE APPROXIMATELY AS SHOWN. DO NOT METAL STAMP.

D

C

B

A

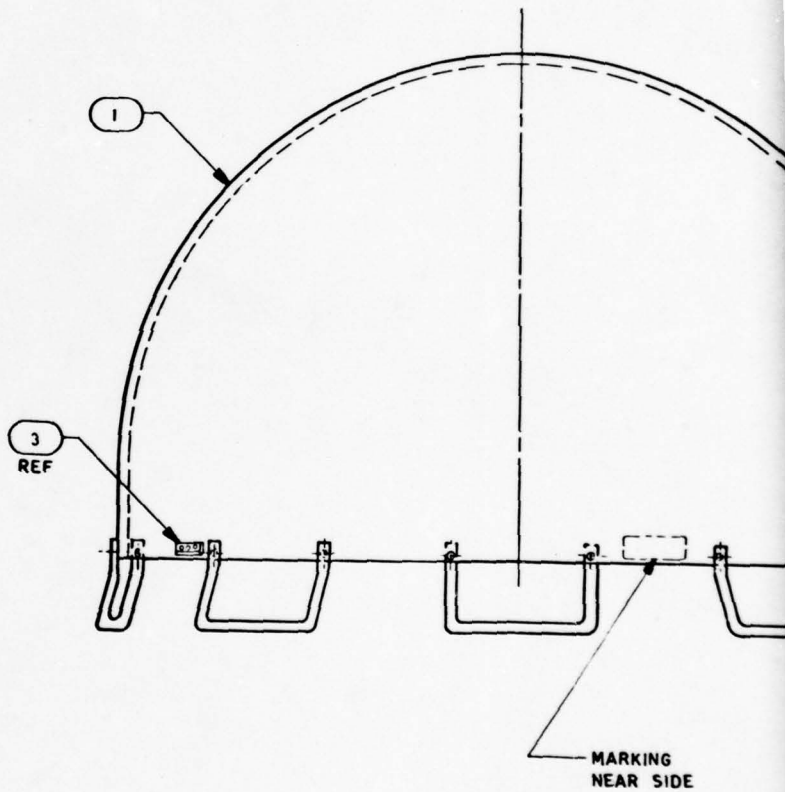

8

7

6

5

4

8

7

6

5

4

FORWARD

3
REF

2
REF

1
REF

VIEW C-C

3

6
(2)

5
(2)
SEE NOTE

SECTION B-B
ROTATED 145°CCW
SCALE 4/1
SEE NOTE 2
4 PLACES

8

7

6

5

4

8

7

6

5

4

NOTES:

1. IDENTIFY WITH CODE IDENT. PART NO. AND REVISION LETTER IAW MIL-STD-130. LOCATE APPROXIMATELY AS SHOWN. METAL STAMPS SHALL NOT BE USED.
2. FOR METHOD OF FABRICATION. SEE DRAWING 5262550.
3. ALL DIMENSIONS ARE AFTER FABRICATION.
4. ALL SURFACES TO BE FREE OF FRAVED FIBERS.
5. RADOME CYLINDRICAL DIAMETER SHALL BE $39.472 \pm .076 - .088$. EXCEPT AS NOTED AT BASE WHICH SHALL BE $39.400 \pm .040 - .000$ DIA FOR A MINIMUM HEIGHT OF 1.06.
6. DIAMETER TO BE CHECKED IN RESTRAINED CONDITION.
7. FACING SHALL COMPRISE OF TWO (2) LAYERS OF 4 OZ GLASS CLOTH (FIND NO. 5) IMPREGNATED WITH A ROOM CURE POLYESTER RESIN (FIND NO. 1) AND PEROXIDE (FIND NO. 4) IAW NOTE 2. GLASS LAYERS TO BE LAYED UP IN QUADRANTS WITH AN OVERLAP NO GREATER THAN .5 RUNNING PARALLEL TO THE CENTER LINE OF THE RADOME. NO TWO (2) SUCH SEAMS SHALL SUPERIMPOSE EACH OTHER. ALL SEAMS, ID AND OD, MUST BE EQUALLY SPACED WITHIN .5. AROUND THE CIRCUMFERENCE. TWO (2) CAP PIECES OF GLASS FITTING OVER THE APEX OF THE RADOME SHALL HAVE CIRCUMFERENTIAL SEAMS NO GREATER THAN .5 WIDE OVER THE QUADRANT LAYERS. FACING THICKNESS SHALL BE $.035 \pm .010 - .005$. (INCLUSIVE OF GEL COAT).
8. EXTERIOR COATING MATERIAL SHALL BE A WHITE GEL COAT (FIND NO. 3) .010 TO .015 THICK BONDED TO THE EXTERIOR FACINGS OF THE RADOME. THIS GEL COAT IS SPRAY COATED ONTO THE RESPECTIVE MOLDS OF THE RADOME AND POLYMERIZED BEFORE GLASS/RESIN LAY-UP.
9. SEAL OPEN EDGES OF SANDWICH TO PREVENT HANDLING DAMAGE AND MOISTURE ABSORPTION. USE POLYURETHANE ELASTOMER (FIND NO. 2).
10. WEIGHT OF RADOME 15.8 LBS MAX.
11. FOR TEST PARAMETERS. SEE DRAWING 5186581.

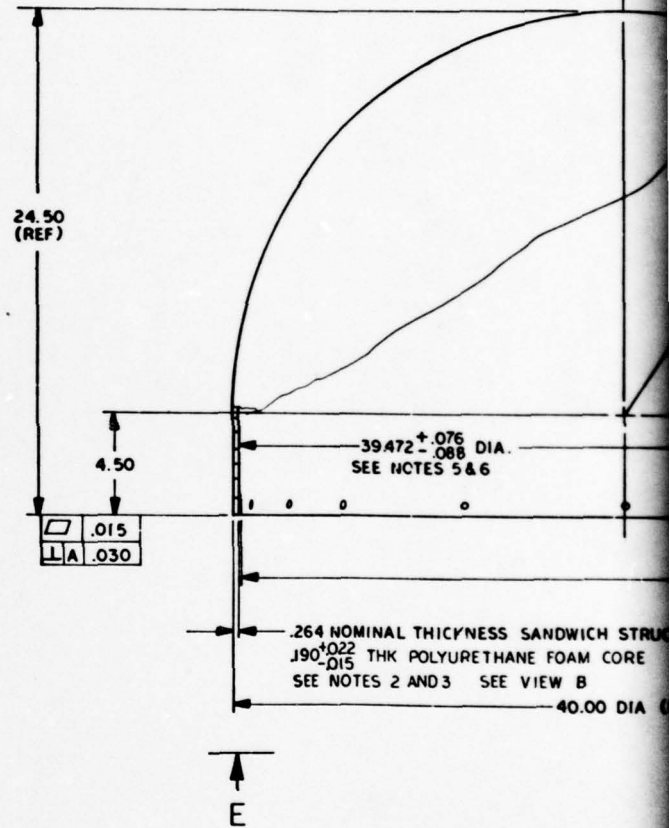

D

C

→

B

A

8

7

6

5

4

4

3

2

D

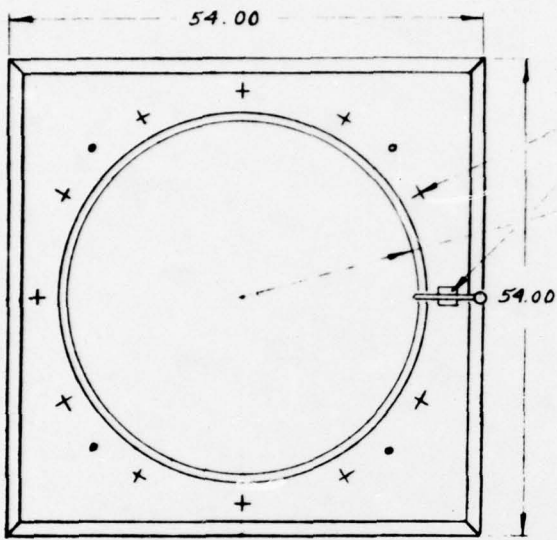

INNER MOLD
HOLDING CLAMPS
12 PLACES

20.000 R

54.00

C

B

A

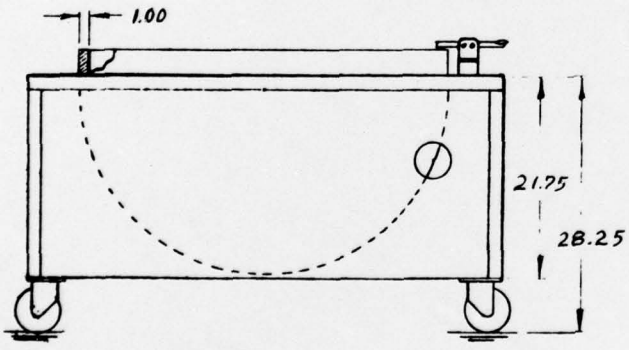

OUTER MOLD

GENERAL CONSTRUCTION
SEE SHEET 3

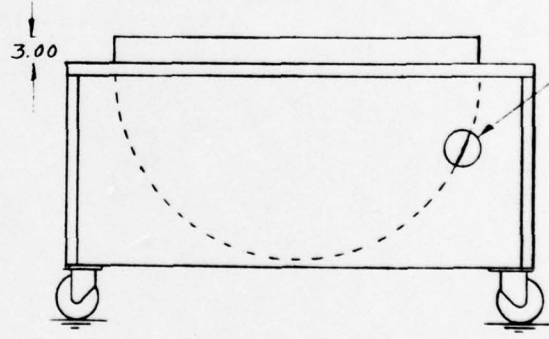

4.0 DIA. ACCESS
HOLE 4 PLACES

INNER PLUG
SEE SHEET

MOUNTING

.062 ALU. SHEET
4 SIDES 4 TOP

4

3

2

FIND NO.	QTY REQ'D	NOMENCLATURE
		UNLESS SPECIFIED ARE TO TOLERANCES ± .010 ± .005
NEXT ASSEMBLY	USED ON	MATERIAL
APPLICATION		FINAL PROTECT
DO NOT APPLY PART NO. TO PART IDENTIFY WITH CODE IDENT. PART NO. AND REVISION LETTER (AW MIL-STD-130) LOCATE APPROXIMATELY AS SHOWN		

3

2

1

REV STATUS OF SHEETS					REVISIONS				
5	4	3	2	1	SHEET NO.	REV	DESCRIPTION	DATE	APPROVED
					REV LTR				

INNER MOLD
HOLDING CLAMPS
2 PLACES

000 R

MOUNTING RING

INNER PLUG
SEE SHEET 2

TAPERED GUIDE
PINS 10.5 LONG
4 PLACES

4.0 DIA. ACCESS
HOLE 4 PLACES

.062 ALU. SHEET
4 SIDES & TOP

FIND NO.	QTY REQ'D	NOMENCLATURE OR DESCRIPTION	FSCM NO	PART OR IDENTIFYING NO.	DOCUMENT NO.	REMARKS AND CONTR USE
----------	-----------	-----------------------------	---------	-------------------------	--------------	-----------------------

PARTS LIST

UNLESS OTHERWISE SPECIFIED DIMENSIONS ARE IN INCHES TOLERANCES ON XX ± 0.10 FRACTIONS ± XX ± 0.03 ANGLES ± 3°		CONTR NO GENERAL DYNAMICS Pasadena Division 93664 Pasadena, CALIFORNIA 91766	MOLD ASSY.			
NEXT ASSEMBLY	USED ON	DATE 10/2/72	RADOME			
APPLICATION		MATERIAL	SIZE / FSCM NO C	DWG NO 24-6-100		
DO NOT APPLY PART NO TO PART IDENTIFY WITH CODE IDENT. PART NO. AND REVISION LETTER IAW MIL-STD-130 LOCATE APPROXIMATELY AS SHOWN		FINAL PROTECTIVE FINISH	SCALE 1" = 1"	UNIT WT	SHEET 1 OF 3	

3

2

1

2

4

3

2

D

FIBERGLASS
INNER PLUG

MOUNTING RING
.375 MILD STEEL

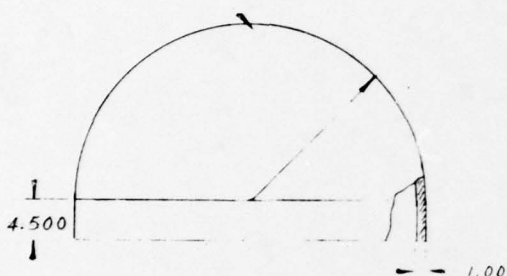

19.736 R

17.50 R

22.00 R

C

.250 VENT HOLES
12 PLACES

.520 MOUNTING
HOLES 6 PLACES

1/2-13 ALL THREAD
6 PLACES
SEE DETAIL A



19.736 R

B

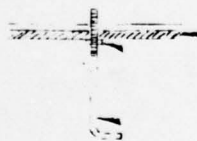

SUPPORT RING
1/2-13 NUT & WASHER
1/2-13 ALL THREAD
GLASSED IN PLACE

DETAIL A

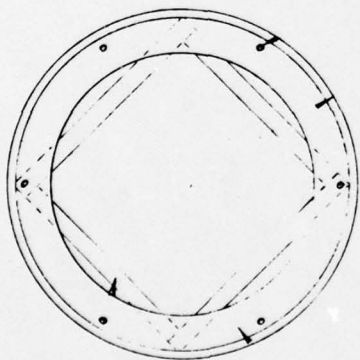

2 X 4 INNER
BRACING

3/4 PLYWOOD
SUPPORT RING

A

4

3

2



1

2

4

3

2

D

C

B

A

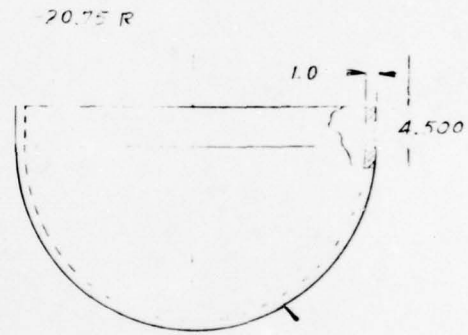
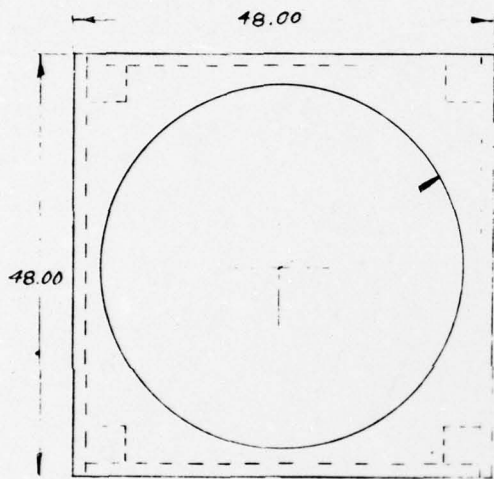

FIBER GLASS INNER MOLD

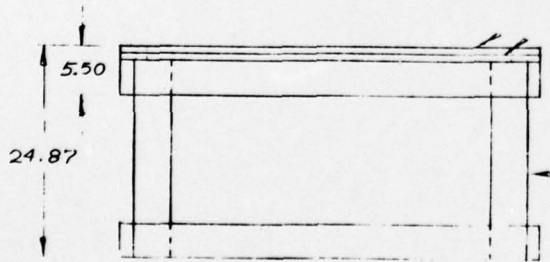

2 PIECES OF
.750 PLYWOOD



4.0 X 4.0 WOOD
4 PLACES

2.0 X 4.0 WOOD
8 PLACES

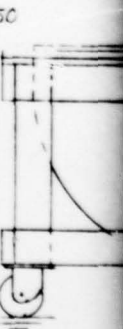

4

3

2

PARTS LIST

GENERAL DYNAMICS		DEPARTMENT OF THE NAVY NAVAL SEA SYSTEMS COMMAND WASHINGTON, DC 20352		CONTRACT NUMBER	DRAWING CODE	REVISION CODE	ISSUE DATE		
POMONA DIVISION 99584 POMONA, CA. 91768				N00024-76-C-7171	1. VENDOR SPEC. CONTROL 2. VENDOR SOURCE CONTROL 3. ASS'GMENT 4. SPEC. - PROC	1. ITEM ADDED 2. ITEM DELETED 3. QTY CHANGED 4. EDIT CORRECT	78/04/82 SHEET 1 OF 1		
CODE IDENT	PL	ITEM NOMENCLATURE			REV LTR	REV NUMBER	REV DATE		
53711	PL 5188237	RADOME			-				
IND NO	QTY REQ	CODE IDENT	IDENTIFICATION NUMBER	NOMENCLATURE	DOCUMENT NUMBER	REFERENCE DESIGNATOR	REMARKS AND CONTRACTOR USE ONLY	REV CODE	DWG CODE
1	AR		5190037	RESIN					
2	AR		5186630	ADHESIVE					
3	AR		5190043-002	GEL COAT					
4	AR			PEROXIDE	MIL-W-81351		800-800-142		
5	AR		5190036-002	GLASS CLOTH					
6	AR		TYPE II, CL 1 2LB/CUFT	POLYURETHANE FOAM	MIL-P-26314		602-800-046		
8	AR		5190044	FIBERS					
	REF		5262530	ASST PROC BRON RADOM					
	REF		5186581	IL OF TEST PRNTR					

PL 5188237

PARTS LIST

GENERAL DYNAMICS		DEPARTMENT OF THE NAVY NAVAL SEA SYSTEMS COMMAND WASHINGTON, DC 20362		CONTRACT NUMBER	DRAWING CODE	REVISION CODE	ISSUE DATE		
POMONA DIVISION 98894 POMONA, CA. 91766				ND0024-76-C-7171	1. VENDOR SPEC. CONTROL 2. VENDOR SOURCE CONTROL 3. ASSEMBLY 4. SPEC. - PROC	1. ITEM ADDED 2. ITEM DELETED 3. QTY CHANGED 4. EDIT CORRECT	78/04/12		
CODE IDENT S3711		PL 5188237	ITEM NOMENCLATURE	REV LTR	REV NUMBER	SHEET 1 OF 1			
ITEM NO	QTY REQ	CODE IDENT	IDENTIFICATION NUMBER	NOMENCLATURE	DOCUMENT NUMBER	REFERENCE DESIGNATOR	REMARKS AND CONTRACTOR USE ONLY	REV CODE	DWG CODE
1	AR		5190037	KEBIN					
2	AR		5186650	ADHESIVE					
3	AR		5190043-002	GEL COAT					
4	AR			PEROXIDE	MIL-W-81351		800-800-142		
5	AR		5190036-002	GLASS CLOTH					
6	AR		TYPE II, CL 1 2LB/CUFT	POLYURETHANE FOAM	MIL-P-26514		802-800-046		
8	AR		5190044	FIBERS					
	REF		5262350	ASSY PROC BRCH RADON					
	REF		5186581	IL OF TEST PMNTR					

PL 5188237

PARTS LIST

GENERAL DYNAMICS		DEPARTMENT OF THE NAVY NAVAL SEA SYSTEMS COMMAND WASHINGTON, DC 20362		CONTRACT NUMBER	DRAWING CODE	REVISION CODE	ISSUE DATE		
POMONA DIVISION 90584 POMONA, CA. 91766				N00024-76-C-7171	1. VENDOR SPEC. CONTROL 2. VENDOR SOURCE CONTROL 3. ASSEMBLY 4. SPEC. - PROC	1. ITEM ADDED 2. ITEM DELETED 3. QTY CHANGED 4. EDIT CORRECT	77/07/07		
CODE IDENT	ITEM NOMENCLATURE			REV LTR	REV NUMBER	REV DATE			
53711	PL 5188236 RADOME ASSY SEARCH			-					
FIND NO	QTY REQ	CODE IDENT	IDENTIFICATION NUMBER	NOMENCLATURE	DOCUMENT NUMBER	REFERENCE DESIGNATOR	REMARKS AND CONTRACTOR USE ONLY	REV CODE	DWG CODE
1	1		5188237	RADOME					
2	5		5188235	HANDLE, LIFTING					
3	4		5189501-001	FASTENER					
4	10		MS51960-68	SCREW					
5	8		MS51959-47	SCREW					
6	8	10001	1819520-013	NUT					
7	10		5188875	SPACER					
8	AR		CLASS 2	PRIMER	MIL-F-23377		597-800-062		
9	AR		FED-STD-595 COLOR 37875	COATING	MIL-C-81773		597-800-969		
	REF		5186581	IL OF TEST FRMTR					

PL 5188236

INITIAL DISTRIBUTION

CHIEF OF NAVAL MATERIAL
 NMAT-08E4 (CAPT L. DITTMAR)
 NAVAL SEA SYSTEMS COMMAND
 NSEA-0354 (H. BYRON)
 NSEA-0354 (T. DRASCHIL)
 NSEA-09G3 (LIBRARY) (2)
 PMS 404-30A (E. GERLACH)
 PMS 400B (EDWIN C. LIBBY) (2)
 PHILADELPHIA DIVISION SEC 6700, NAVAL SHIP
 ENGINEERING CENTER
 CODE 6721C (E. SIGAL)
 NAVAL AIR SYSTEMS COMMAND
 NAIR-52022 (R. RETTA)
 NAVAL ELECTRONIC SYSTEMS COMMAND
 NELEX-5045 (J. A. WYATT)
 NELEX-50451 (R. HILL)
 NAVAL MATERIAL INDUSTRIAL
 RESOURCES OFFICE
 CODE 01 (W. SAFIER) (2)
 CODE 224 (W. J. WELSH) (2)
 NAVAL WEAPONS CENTER
 CODE 55804 (D. BULLATT)
 NAVAL AIR REWORK FACILITY
 NAVAL AIR STATION
 NORTH ISLAND
 CODE 330 (F. GALE)
 NAVAL AVIONICS CENTER
 CODE 214.4 (L. HALBIG)
 ARMY INDUSTRIAL BASE ENGINEERING ACTIVITY
 DRXIB-MT (C. MC BURNEY)
 DRXIB-MT (F. ANDERSON)
 ARMY MISSILE RESEARCH AND DEVELOPMENT COMMAND
 DRDMI-EAA (R. KOTLER)
 ARMY MATERIALS AND MECHANICS RESEARCH CENTER
 DRXMR-RD (S. TOZLOWSKI)
 ARMY COMMUNICATIONS RESEARCH AND DEVELOPMENT
 COMMAND
 DRDCL-PP-I-PE-I (STAN SOKOLOVE)
 ARMY ARMAMENT & MATERIAL READINESS COMMAND
 MANUFACTURING TECHNOLOGY DIVISION
 AIR FORCE MATERIALS LABORATORY
 AFML/LT (J. MATTICE)
 AFML/LTN (R. TOMASHOT)
 GENERAL DYNAMICS
 P.O. BOX 2507
 POMONA, CA 91766
 MARVIN C. ABRAMS, MZ 4-26 (12)
 RAYTHEON
 MISSILE SYSTEMS DIVISION
 BEDFORD, MA 01730
 EUGENE MC MANUS, MARKETING MGR.
 LABORATORY SUPPORT TECHNOLOGY
 MC DONNELL DOUGLAS ASTRONAUTICS
 5301 BOLSA AVENUE
 HUNTINGTON BEACH, CA 92647
 H. K. LAUER, MGR., ADVANCED
 MANUFACTURING ENGINEERING
 A. J. CWFERTNY, ADVANCED COMPOSITE
 STRUCTURES DIVISION
 MARTIN MARIETTA
 ORLANDO DIVISION
 P.O. BOX 5837
 ORLANDO, FL 32805
 EDWARD MINARSCH, MGR.,
 MANUFACTURING ENGINEERING &
 ADV. MANUFACTURING TECH.

HUGHES AIRCRAFT
 BUILDING 600, M/S D-131
 P.O. BOX 3310
 FULLERTON, CA 92634
 TERRY FERNANDEZ
 LOCKHEED MISSILES & SPACE CO.
 1111 LOCKHEED WAY
 SUNNYVALE, CA 94088
 BEN JUSCEN, SUPERVISOR,
 MANUF. RESEARCH 0/47-61,
 B/150
 BOEING AEROSPACE CO.
 P.O. BOX 3999
 SEATTLE, WA 98214
 CHARLES HAMMERBERG, E/E MANUF.
 TECHNOLOGY, RESEARCH & ENGINEERING
 DIVISION
 TELEDYNE RYAN AERONAUTICAL
 2701 HARBOR DRIVE
 SAN DIEGO, CA 92113
 R. T. WILLIAMS, MATERIALS &
 PROCESSES
 MC DONNELL DOUGLAS ASTRONAUTICS
 ST. LOUIS, MO 63166
 L. R. SANDERS, MATERIALS &
 PROCESS DIVISION
 EXPANDED RUBBER & PLASTICS CORP.
 14000 S. WESTERN AVENUE
 GARDENA, CA 90249
 JOHN DIXON, VICE PRES.
 GENERAL ELECTRIC CO.
 6151 WEST CENTURY BLVD.
 LOS ANGELES, CA 90045
 C. E. BOLD, REPRESENTATIVE
 AIRCRAFT EQUIP.
 ANDREW CALIFORNIA CORP.
 711 E. MARYLIND AVENUE
 CLAREMONT, CA 91711
 DICK GUNDRUM, Q.C. MGR.
 HUGHES AIRCRAFT COMPANY
 1901 MALVERN
 FULLERTON, CA 92634
 L. J. QUINTANA,
 MATERIALS & PROCESSES SECT.,
 COMPONENTS & MAT. DEPT.,
 GROUND SYSTEMS GROUP
 MARTIN MARIETTA AEROSPACE
 SAN BERNARDINO DIST. OFFICE
 505 N. ARROWHEAD DRIVE, SUITE 100
 SAN BERNARDINO, CA 94201
 H. H. HOWELL, JR., MGR.
 SWEDLOW, INC.
 12122 WESTERN AVE.
 GARDEN GROVE, CA 92645
 JOE SULLIVAN
 HEATH TECNA CORP
 PRECISION STRUCTURES DIVISION
 19819 84TH AVE., S.
 KENT, WA 98031
 DONALD COLCLOUGH
 DEFENSE DOCUMENTATION CENTER (12)