

AD-A068 753

STANFORD UNIV CALIF HIGH TEMPERATURE GASDYNAMICS LAB F/G 21/2  
DEVELOPMENT OF COMBUSTION DIAGNOSTICS AND APPLICATION TO TURBUL--ETC(U)  
APR 79 R K HANSON, C T BOWMAN F49620-78-C-0026

UNCLASSIFIED

AFOSR-TR-79-0522

NL

| OF |

AD  
AO 68 753

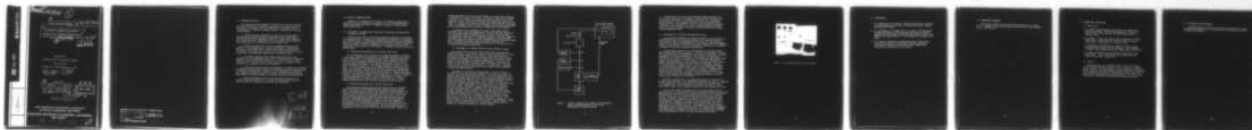

END  
DATE  
FILMED  
6 --79  
DDC

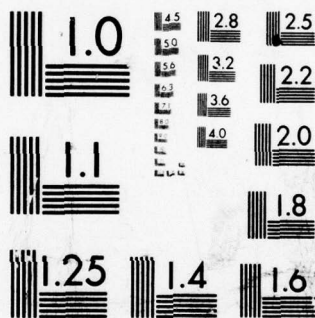

MICROCOPY RESOLUTION TEST CHART  
NATIONAL BUREAU OF STANDARDS-1963-A

AD A068753

DDC FILE COPY

<sup>18</sup> APOSR <sup>19</sup> TR-79-0522

<sup>5</sup>  
B.S.

<sup>9</sup> Interim Scientific Report, 16 Feb 78-15 Mar 79

<sup>6</sup>

on

DEVELOPMENT OF COMBUSTION DIAGNOSTICS  
AND APPLICATION TO TURBULENT COMBUSTION

Contract F49620-78-C-0026

<sup>15</sup>

LEVEL A

Prepared for  
Air Force Office of Scientific Research  
For the Period  
February 16, 1978 to February 15, 1979

<sup>16</sup> 2308

<sup>17</sup> A2

<sup>10</sup>

Submitted by

R. K. Hanson C. T. Bowman

<sup>11</sup> apr 79

<sup>12</sup> 13p.

DDC  
RECEIVED  
MAY 18 1979  
A

Approved for public release;  
distribution unlimited.

HIGH TEMPERATURE GASDYNAMICS LABORATORY  
MECHANICAL ENGINEERING DEPARTMENT

STANFORD UNIVERSITY ■ STANFORD, CALIFORNIA

404078

79 05 18 041

B



**AIR FORCE OFFICE OF SCIENTIFIC RESEARCH (AFSC)**

**NOTICE OF TRANSMITTAL TO DDC**

This technical report has been reviewed and is approved for public release IAW AFR 190-12 (7b).  
Distribution is unlimited.

**A. D. BLOSE**

**Technical Information Officer**

## 1.0 RESEARCH OBJECTIVES

This program provides fundamental research in the area of advanced non-interfering optical diagnostics, particularly for application to the measurement of chemically reacting turbulent flow parameters and the interpretation of combustion dynamic phenomena. Objectives of the work are as follows:

a. Develop and apply tunable diode lasers for the measurement of major and minor species concentrations and temperature under steady, fluctuating and sooting combustion conditions. Species will include CO, CO<sub>2</sub>, and possibly H<sub>2</sub>O. Experiments will be conducted in flat-flame and slot burners and in a two-dimensional reacting shear flow.

b. Utilize the diode laser to measure fundamental spectroscopic parameters (line strengths and collision halfwidths) of combustion gas species in a flat-flame burner. Species will include CO and possibly CO<sub>2</sub> and H<sub>2</sub>O. These data are required for proper interpretation of species concentration and temperature measurements in combustion flows.

c. Investigate coupling effects between reaction kinetics and turbulence in a two-dimensional shear flow. Experiments will be conducted using CO or NO in one reactant stream and O<sub>3</sub> or O<sub>2</sub> in the other stream. Diagnostics will include the diode laser, high-speed photography, conventional hot-wire anemometry and a laser anemometer.

d. Investigate and apply laser-based diagnostic techniques for spatially- and temporally-resolved measurements of temperature and species concentrations in turbulent reacting flows. Techniques to be considered are fluorescence and variations of Raman spectroscopy including spontaneous Raman, coherent Raman (CARS) and stimulated Raman, and tunable UV/visible laser absorption.

e. Compare measurements obtained with new laser techniques with those from existing methods (e.g., conventional spectroscopy, and point sampling probes for temperature and species concentrations).

APPROVED BY	
RTM	DATE BOOKED <input checked="" type="checkbox"/>
DDC	FILE NUMBER <input type="checkbox"/>
UNCLASSIFIED	<input type="checkbox"/>
NOTIFICATION	
BY	
INVESTIGATOR/OPERABILITY GROUP	
DATE	APPROV. AND/OR REVIEW
A	

## 2.0 STATUS OF RESEARCH EFFORT

Research is in progress on two topics: (1) laboratory flame studies using tunable laser absorption spectroscopy; and (2) an investigation of turbulent reacting shear flows. A summary of progress in these program areas follows below.

### 2.1 Development of Tunable Laser Absorption Spectroscopy and Applications to Laboratory Flames

During this past year, we have made substantial progress in the development and application of tunable laser absorption spectroscopy as a diagnostic for combustion flows. Significant accomplishments include successful measurements of CO concentration and temperature in a variety of steady, fluctuating and sooting flames. Details of completed work have been given in recent publications (see Section 3 of this report). A summary of relevant activities follows below:

#### a) Temperature Measurements with a Tunable Diode Laser

In this research, a new technique for in situ measurements of temperature has been developed and validated in the steady post-flame gases above a flat flame burner. The technique involves rapidly tuning a diode laser across a spectral interval encompassing two nearly coincident vibration-rotation lines originating from two different vibrational levels of the same infrared-active species. The relative absorption in these two lines can be a sensitive indicator of the average temperature along the line-of-sight. By fully resolving both lines, possible effects of different line-width are eliminated. Validation of this new technique was accomplished using fine-wire thermocouples (radiation-corrected) in atmospheric-pressure methane-air flames over a range of equivalence ratios. CO was the absorbing species. Other important aspects of this completed work include a survey of optimum absorption line pairs in CO and development of a scheme to enable modulation of the laser in times as short as 50  $\mu$ sec. A more extensive description of this work has been published (see Section 3).

#### b) Species Measurements with a Tunable Diode Laser

Carbon monoxide concentrations have been measured in the postflame region of laminar, premixed hydrocarbon/air flames using both tunable diode laser absorption spectroscopy and conventional probe sampling. The optical technique employed a diode laser tuned to a specific vibration-rotation line in the CO infrared absorption spectrum at  $\nu = 2077.1 \text{ cm}^{-1}$ . In the sampling experiments, combustion gases were extracted using an uncooled, aerodynamically-quenched quartz microprobe and analyzed for CO and CO<sub>2</sub> using NDIR instruments. Results of the laser absorption measurements of CO concentration performed in fuel-rich flames were in good agreement with equilibrium predictions based on metered fuel and air flowrates and measured local temperature. The initial sampling probe measurements, which were made in both lean and rich flames, yielded total

carbon consistent with the input stoichiometry, but indicated substantial conversion of CO to CO<sub>2</sub> in the probe. A new water-cooled probe, designed to minimize CO conversion has subsequently been constructed and is now ready for testing. Flow controls for the flat flame burner have also been improved to enable more accurate determinations of the fuel-air equivalence ratio. An extensive series of tests to compare laser absorption and probe-based CO measurements will be carried out during the next few months.

In addition to the experiments in steady, clean flames already described, laser absorption measurements of CO have also been carried out in a fluctuating flame environment and in a heavily soot-laden flame. The objective in these initial experiments has been to show the versatility of tunable laser absorption as a combustion diagnostic technique under conditions where most other techniques (conventional and laser-based) would fail. Preliminary experiments have been highly successful and results recently have been published (see Section 3). Further work will be carried out during this next year.

#### c) Development of a Tunable UV/Visible Laser Absorption System

The success of our work with tunable diode laser absorption has stimulated interest in developing a laser absorption system for the ultraviolet and visible regions of the spectrum. Such a device would be particularly useful for measuring low concentrations of radical species and thus would complement the infrared diode laser system which is best suited for species present in higher concentrations. In the past few months, we have designed a suitable tunable UV/visible system and have placed an order for the critical element, a ring dye laser. (Purchase of this laser was jointly supported by three research contracts/grants including the AFOSR program.)

A schematic of the overall proposed system is shown in Figure 1. An argon-ion laser (Spectra Physics Model 171) will be used to pump the ring dye laser (Spectra Physics Model 380A). For flame experiments, the narrow-linewidth dye laser output will be repetitively modulated in wavelength over a single absorption line using a standard scanning electronics package available with the dye laser. For UV absorption studies, an intracavity frequency doubling element will be used. The laser wavelength will be set using a monochromator in conjunction with the observed absorption record. Variations in laser power during each modulation cycle will be minimized with a commercial dye laser light regulator (already available) which is connected to the pump laser power supply through a feedback control circuit. A direct measurement of the change in wavelength during each scan, needed to infer the absorption line halfwidth, can be made with a conventional spectrum analyzer or Fabry-Perot etalon, as is done with the tunable diode laser. Finally, the largest fraction of the laser output passes through the experiment, either the flat flame or another reactive flow, and onto a single detector. The outputs of the spectrum analyzer and the absorption detector will be recorded on a digital oscilloscope or signal averager.

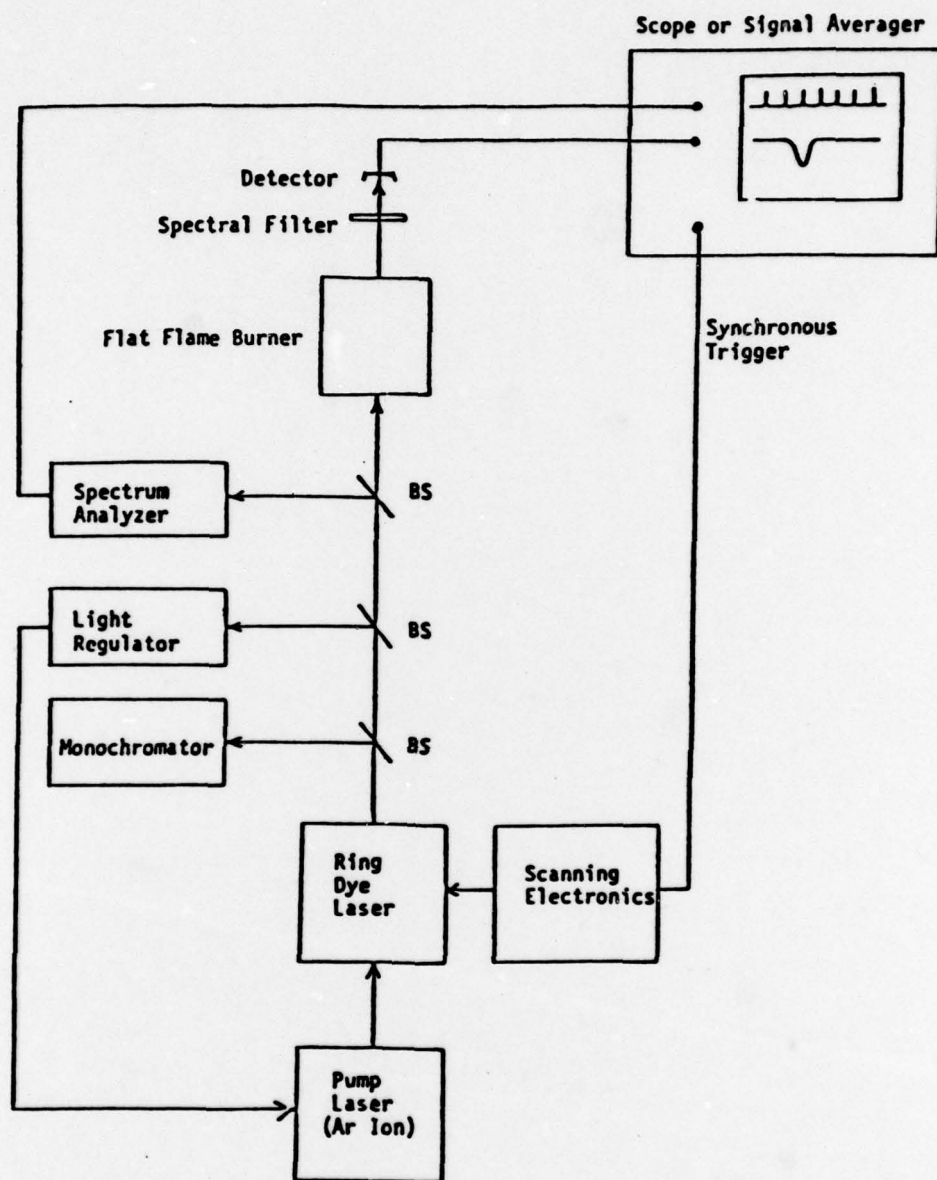

Figure 1. Schematic diagram of new tunable laser absorption system for high-resolution UV and visible spectroscopy of combustion gases.

Initial work will focus on developing measurement techniques for OH in a flat flame burner. We expect to work near  $3100 \text{ \AA}$ , which should be accessible using R6G or RB dye and an RDP crystal as a frequency-doubling element. The estimated detection limit for OH using tunable laser absorption is approximately 1 ppm for typical laboratory combustor conditions. Once developed, of course, the same diagnostic technique could be applied to several other radical species of interest in characterizing combustion flows.

## 2.2 Investigation of Turbulent Reacting Shear Flows

Coupling of fluid dynamic and chemical processes is a major factor in governing performance and pollutant emissions from combustion devices. At the present time, our understanding of the nature of this coupling is insufficient to permit extrapolation of results obtained from one combustion device to other devices or to allow quantitative prediction of the effects of changes in operating conditions on performance.

In the present program, we are investigating the coupling between fluid dynamic and chemical processes in turbulent reacting flows. Several flow configurations were considered for the proposed experiments, including axisymmetric jets and two-dimensional shear layers. The qualitative similarities of turbulence structures in two-dimensional non-reacting shear layers and those found in the shear layers of turbulent flame burners suggest that measurements on two-dimensional reacting shear layers should provide considerable insight into the effects of turbulence structure on reaction rates in turbulent flames. From an experimental standpoint, the two-dimensional geometry offers several distinct advantages. There is extensive documentation of the turbulence structure of geometrically similar non-reacting flows. In addition, the geometry is amenable to advanced optical diagnostic techniques currently available in our laboratory for simultaneous, non-perturbing, in situ measurements of species concentration, temperature and velocity.

During the previous year, a two-dimensional shear flow facility was designed and constructed. The experimental configuration, Figure 2, consists of two atmospheric-pressure gas streams separated by a splitter plate in a rectangular duct. Gas is supplied to the shear flow facility from a flow control system, which accurately meters up to four separate gas flows.

At the present time, preliminary tests are being conducted on non-reacting flows to characterize the approach flow and the flow field structure downstream from the splitter plate using conventional hot-wire anemometry. The preliminary tests are being conducted using flowing  $N_2$  in both gas streams. Subsequent tests will be conducted with trace amounts of NO or CO in one of the gas streams and with mixtures of Ar and He to validate instrumentation techniques to be used in the reacting flow tests and to obtain data on entrainment and mixing in non-reacting flows to assist in interpretation of reacting flow data. Measurements to be made include high-speed schlieren motion pictures of the flow field, hot-wire anemometer measurements of the instantaneous velocity in the mixing layer, time-mean probe measurements of species concentration in the mixing layer and time-resolved measurements of NO or CO using the tunable diode laser.

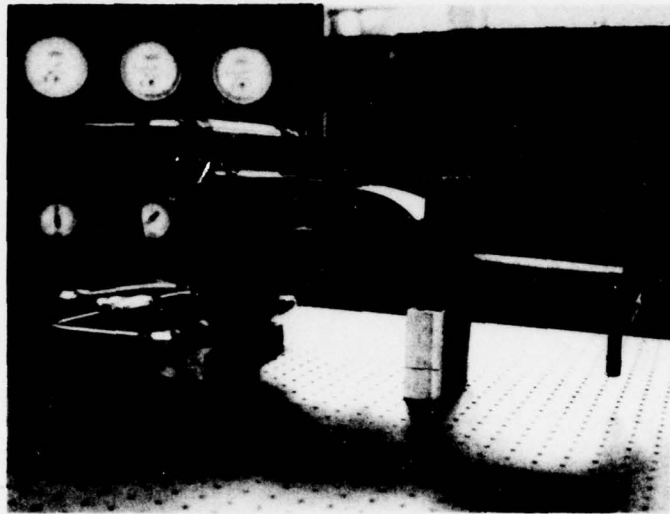

Figure 2. Two-dimensional shear flow facility.

### 3.0 PUBLICATIONS

1. R. K. Hanson and P. K. Falcone, "Temperature Measurement Technique for High-Temperature Gases Using a Tunable Diode Laser," Applied Optics 17, 2477 (1978).
2. S. M. Schoenung, R. K. Hanson and P. K. Falcone, "CO Measurements in Combustion Gases by Laser Absorption Spectroscopy and Probe Sampling," Western States Section/Combustion Institute Paper 78-46, October 1978, Laguna Beach, CA. To be submitted to Combustion and Flame.
3. R. K. Hanson, "Combustion Gas Measurements Using Tunable Laser Absorption Spectroscopy," AIAA Reprint 79-0086, presented at 17th Aerospace Sciences Meeting, New Orleans, January 1979. Submitted for publication to AIAA Journal.

#### 4.0 PROFESSIONAL PERSONNEL

The faculty involved in this research are Professors R. K. Hanson and C. T. Bowman; participating graduate students are Ms. Susan Schoenung and Mr. Steve Masutani.

## 5.0 PROFESSIONAL INTERACTIONS

### a) Talks Given:

R. K. Hanson: "High-Temperature NO<sub>x</sub> Kinetics and Tunable Diode Laser Spectroscopy". Invited talk presented at the Exxon Research Forum, Exxon Research and Engineering, Linden, N.J., March 30, 1978.

R. K. Hanson: "Tunable Laser Spectroscopy of Combustion or Shock-Heated Flows". Talk presented at General Electric Research Laboratories, Schenectady, N.Y., March 31, 1978.

S. M. Schoenung: "CO Measurements in Combustion Gases by Laser Absorption Spectroscopy and Probe Sampling". Paper presented at Western States Combustion Meeting, Laguna Beach, October 1978.

R. K. Hanson: "Combustion Gas Measurements Using Tunable Laser Spectroscopy". Paper presented at 17th Aerospace Sciences Meeting, New Orleans, January 1979.

### b) Visitors:

During this year, we entertained several visitors interested in this research program, including: Drs. M. Lapp and M. Penney of General Electric, Dr. Alan Eckbreth of United Technology Corporation, Profs. John Daily and Tony Oppenheim from the University of California, Drs. Dan Hartley, Don Hardesty, William Flower, Robert Green and Robert Dibble from Sandia Livermore Laboratories, Dr. Charles Fisher from ARO, Dr. Fred Dryer from Princeton University and others.

## 6.0 APPLICATION OF NEW KNOWLEDGE

This AFOSR-supported research has yielded new techniques for species and temperature measurement in high-temperature flows of general utility in aerospace technology.



(Block 20 continued)

line profiles in times as short as 100 microseconds. A conventional micro-probe sampling system to monitor CO and CO<sub>2</sub> concentrations has been constructed to enable comparisons between laser-based and conventional measurements; thermocouples have been used to allow comparisons with laser-based temperature measurements. Initial results in fuel-rich flames show good agreement. Work is in progress to modify the burner system to allow comparisons over a wider range of stoichiometries.

We have also initiated assembly of two new facilities for studies of the dynamics of fluctuating or turbulent combustion flows. The first facility is essentially a flat flame burner modified to provide repetitive fluctuations in stoichiometry and flame temperature. The second facility is a two-dimensional reacting shear flow facility. The intent is to study the coupling between fluid dynamic and chemical processes in the turbulent mixing layer. The selection of the two-dimensional geometry should enable use of line-of-sight optical techniques including diode laser spectroscopy.