

AD-A068 858

NAVAL ELECTRONIC SYSTEMS TEST AND EVALUATION DETACHME--ETC F/G 5/2
FLEET RELIABILITY ASSESSMENT PROGRAM. VOLUME 4. AN/URC-85 UHF R--ETC(U)
SEP 77

UNCLASSIFIED

NL

1 OF 1
ADA
068858

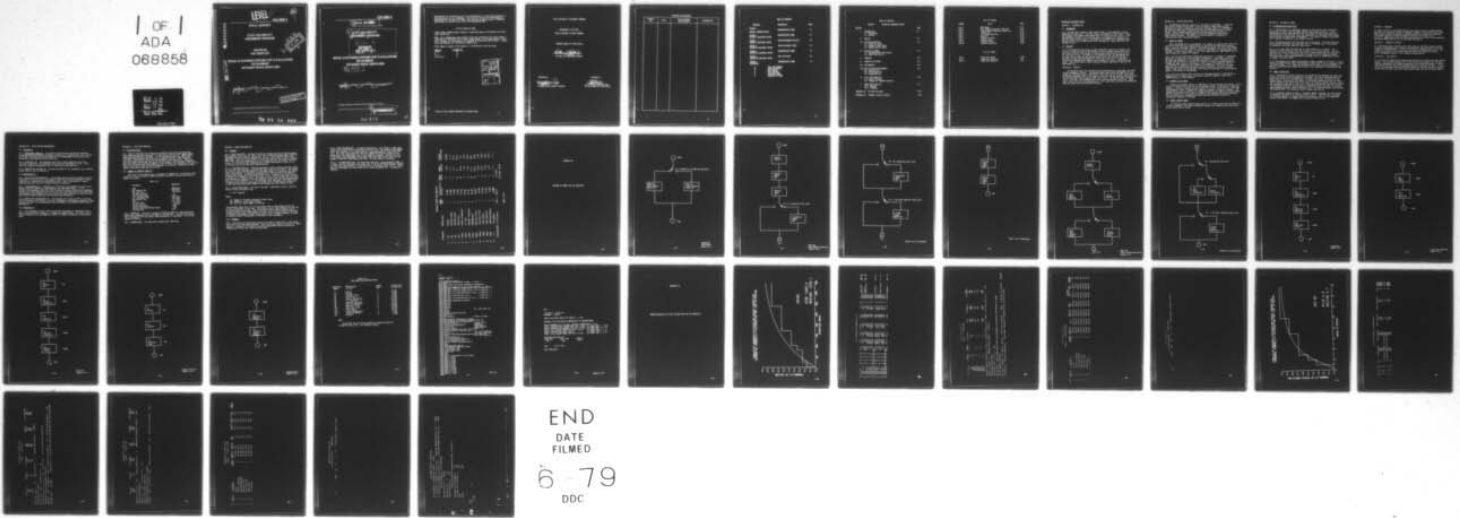

END
DATE
FILMED
6-79
DDC

LEVEL *111*

(12)

A068857

VOLUME 4

A068858

FINAL REPORT

**FLEET RELIABILITY
ASSESSMENT PROGRAM**

**AN/URC-85
UHF RADIO SET**

DDDC
RRRMP
MAY 23 1979
RLS/TL

DDC FILE COPY

**NAVAL ELECTRONIC SYSTEMS TEST & EVALUATION
DETACHMENT
PATUXENT RIVER, MARYLAND**

Each transmittal of this document outside of the Department must have approval of the issuing Service.

This document has been approved for public release and sale; its distribution is unlimited.

Published by direction of Commander, Naval Electronics Systems Command.

79 04 24 042

VOLUME 4

⑨ FINAL REPORT.

⑥ FLEET RELIABILITY
ASSESSMENT PROGRAM,

Volume 4.

AN/URC-85
UHF RADIO SET, Volume 4.

**NAVAL ELECTRONIC SYSTEMS TEST & EVALUATION
DETACHMENT
PATUXENT RIVER, MARYLAND**

⑫ 45 p.

Each transmittal of this document outside of the Department must have approval of the issuing Service.

Published by direction of Commander, Naval Electronics Systems Command.

⑪
1 SEPTEMBER 1977

408 408

elf

Reproduction for non-military use of the information or illustration contained in this publication is not permitted. The policy for military use reproduction is established for the Army in AR 380-5, for the Navy and Marine Corps in OPNAVINST 5510.1B and for the Air Force in Air Force Regulation 205-1.

LIST OF EFFECTIVE PAGES

Insert latest changed pages; dispose of superseded pages in accordance with applicable regulations.

NOTE: On a changed page, the portion of the text affected by the latest change is indicated by a vertical line, or other change symbol, in the outer margin of the page. Changes to illustrations are indicated by miniature pointing hands. Changes to wiring diagrams are indicated by shaded areas.

Total number of pages in this manual is 44 consisting of the following.

<u>PAGE NO.</u>	<u># CHANGE NO.</u>
TITLE	0
A	0
i to v	0
4-1 to 4-37	0

ACCESSION for	
NTIS	White Section <input checked="" type="checkbox"/>
DDC	Buff Section <input type="checkbox"/>
UNANNOUNCED	<input checked="" type="checkbox"/>
JUSTIFICATION	<i>Health</i>
BY	<i>file</i>
DISTRIBUTION/AVAILABILITY CODES	
Dist.	NIL and/or SPECIAL
A	

Zero in this column indicates an original page.

FLEET RELIABILITY ASSESSMENT PROGRAM

DEPARTMENT OF THE NAVY
NAVAL ELECTRONIC SYSTEMS COMMAND

PREPARED UNDER THE DIRECTION OF

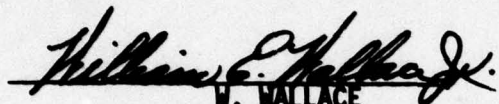
W. WALLACE
RELIABILITY ENGINEERING BRANCH

REVIEWED BY

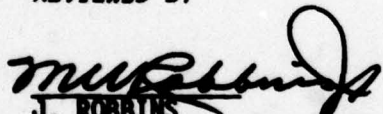
J. ROBBINS
SYSTEMS EFFECTIVENESS DIVISION

APPROVED BY

G. FRIESE, CAPTAIN, USN
DEP CDR LOGISTICS DIRECTORATE

RECORD OF CHANGES

CHANGE NO.	DATE	TITLE OR BRIEF DESCRIPTION	ENTERED BY

TABLE OF CONTENTS

CONTENTS	PREPARED BY	PAGE
VOLUME 1 GENERAL PROGRAM REPORT	NAVMPNSUPPCEN CRANE	1-1
VOLUME 2 AN/SSR-1 EQUIPMENT REPORT	NAVMPNSUPPCEN CRANE	2-1
VOLUME 3 AN/WSC-3 EQUIPMENT REPORT	NAVELEXSYSENGCEN VALLEJO	3-1
VOLUME 4 AN/URC-85 EQUIPMENT REPORT	NESTED PATUXENT RIVER	4-1
VOLUME 5 AN/URC-62 EQUIPMENT REPORT	NAVMPNSUPPCEN CRANE	5-1
VOLUME 6 AN/UYK-20 EQUIPMENT REPORT	NOSC SAN DIEGO	6-1
VOLUME 7 APPENDICES	NAVMPNSUPPCEN CRANE	7-1
A	FRAP TEAM MEMBERS	
B	SAMPLING MATRIX	
C	DATA CODING	
D	DATA ANALYSIS	
E	LOGISTICS MODEL	
F	GLOSSARY OF TERMS	

TABLE OF CONTENTS

VOLUME 4

AN/URC-85 EQUIPMENT REPORT

SECTION	PAGE
I INTRODUCTION	4-1
1-1 Background	
1-2 Mission	
II RESULTS	4-1
III SYSTEM DESCRIPTION	4-2
3-1 Radio Set Group	
3-2 Antenna Filter Group	
3-3 Remote Control Group	
IV RELIABILITY MODEL	4-3
4-1 System/Mission Description	
4-2 Model Description	
V PROBLEMS	4-4
VI CORRECTIVE ACTIONS	4-4
VII COST-BENEFIT	4-4
VIII SPECIFICATION REQUIREMENTS	4-5
8-1 Reliability	
8-2 Maintainability	
8-3 Accessibility	
IX FLEET DATA ANALYSIS	4-6
9-1 Data Collection	
9-2 Summary of Computer Analysis	
X DEPOT DATA ANALYSIS	4-7
10-1 Methods	
10-2 Findings	
APPENDIX 4A Reliability Model	4-10
APPENDIX 4B Computer Analysis Results	4-25

LIST OF FIGURES

FIGURE	TITLE	PAGE
4-A.1	Mode Model	4-11
4-A.2	Dual Channel Operation, Mode One	4-12
4-A.3	Single Channel Operation, Mode Two	4-14
4-A.4	Transmitter	4-17
4-A.5	1KW Linear Amplifier	4-18
4-A.6	Receiver	4-19
4-A.7	Support Circuits	4-20
4-A.8	Antenna Group	4-21
4-A.9	Program Listing	4-23
4-A.10	Sample Program Run	4-24

LIST OF TABLES

4-A.1	Model Data Sheet	4-22
4-9.1	Summary of Analysis	4-6
4-10.1	Depot Data Analysis	4-9

AN/URC-85 EQUIPMENT REPORT

SECTION I. INTRODUCTION

1-1 BACKGROUND

1-1.1 Collins Radio Company, Cedar Rapids, Iowa, is the contractor for the AN/URC-85 UHF radio sets. The radio sets are designed for NTDS (Navy Tactical Data System) UHF communications aboard DLG, CV, CVN and CG-class ships. Radio Set AN/URC-85 consists of a radio set group, an antenna filter group and an optional remote control group. Equipment for the AN/URC-85 is designed using the existing Collins U-1000 series of UHF transceivers, power amplifiers and antenna filters.

1-2 MISSION

1-2.1 The AN/URC-85 radio sets are UHF transceivers used as an integral part of Link 4 (primarily used by the Automatic Carrier Landing System) and Link 11 NTDS (Navy Tactical Data System) to furnish data communications from ship-to-air and ship-to-ship. The design of the AN/URC-85 radio set complements the HF radio sets in tactical data system installations and provides the UHF RF functions to meet the requirements for both Link 4 and Link 11 subsystems. The sets are automatically tuned and are intended for use on a continuous duty cycle. They can be used in either simplex or duplex operation in the voice or data modes.

SECTION II. RESULTS

The AN/URC-85 meets the reliability and maintainability requirements set forth in the procurement contract. The observed operational mean-time-between-failures (MTBF) was 1489 hours with a verification ratio (see 10-1.3) of 0.95. This gives an observed equipment MTBF of 1567 hours, triple the 500 hour minimum MTBF specified. The observed mean-time-to-repair (MTTR) was 4 hours. At the 90% lower confidence limit, 1.53 hours, the AN/URC-85 meets the 2 hour maximum MTTR specified. Therefore, within the limits of sampling error, this study cannot show that the AN/URC-85 does not comply with the MTTR specification.

SECTION III. SYSTEM DESCRIPTION

3-1 The AN/URC-85 radio set consists of two groups of equipment - a radio set group and an antenna filter group - plus an optional remote control group. The radio set group is mounted in Electrical Equipment Cabinet CY-7403/URC-85. The antenna filter group is mounted in Electrical Equipment Cabinet CY-7404/URC-85. Each equipment cabinet includes the necessary wiring harnesses, cooling systems, and limited numbers of discrete components necessary for power control purposes. The majority of the electronics is composed of organizational-level replaceable modules.

3-2 RADIO SET GROUP.

Radio Set AN/URC-85 is a two-channel, full duplex (or simplex) UHF radio transceiver for data and voice communications in the 225.00 to 399.95 MHz frequency band. Electrical Equipment Cabinet CY-7403/URC-85 contains two full-duplex AN/URC-82A UHF transceivers, four radio set controls (C-9059/UR), an indicator panel (ID-1953/UR), a local control panel, a 1 KW linear power amplifier (AM-6520/UR) and its high-voltage power supply (PP-6799/UR).

3-2.1 Each of the 3500-channel AN/URC-82A transceivers is capable of independent operation, allowing use in a multi-mode configuration. These modes consist of AM (amplitude modulation), FM (frequency modulation), and FSK (frequency shift keying), each of which is available in a duplex or simplex frequency capability. Transmitter power output to the antenna filter group is 100 watts for the FM and FSK modes of operation, and 30 watts for the AM mode. The linear RF power amplifier can be utilized with either transmit channel to increase a selected channel power output to the antenna filter group to 1000 watts for the FM and FSK modes, or 250 watts for the AM mode.

3-2.2 The local control panel in Electrical Equipment Cabinet CY-7403/URC-85 is equipped with two handset jacks that may be used for orderwire, local voice communications, or test purposes.

3-3 ANTENNA FILTER GROUP.

Electrical Equipment Cabinet CY-7404/URC-85 contains two UHF multiplexers: Multiplexer TD-1118/UR, which consists of two Bandpass Filters F-1332/UR and a combining network, is used for receive; and Multiplexer TD-1117/UR, which consists of two 1000-watt Bandpass Filters F-1396/UR and a combining network, is used for transmit. The antenna filter group functions as an impedance matching and combining network between the UHF transceivers of the radio set group and the transmit and receive antennas. Both multiplexers are automatically tuned when the associated receiver or transmitter frequency is selected.

3-4 REMOTE CONTROL GROUP.

The optional remote control group consists of a control panel and four Radio Set Controls C-9059/UR. All modes of operation except local handset may be controlled by the remote control group.

SECTION IV. RELIABILITY MODEL

4-1 SYSTEM/MISSION DESCRIPTION

4-1.1 The UHF Radio Set, AN/URC-85, consists of two 100-watt UHF transmitters and two UHF receivers sharing common cabinets and support circuitry. A one-thousand-watt linear power amplifier may be switched in behind one transmitter. The transmitters and receivers are slice compatible with the AN/ARC-138 airborne system and can be powered down independently. The system is remote controllable and is capable of operating under computer control.

4-1.2 The mission profile for the radio set is not known. Field data indicates that different platforms are using radio sets in different ways, as evidenced by transmitter and power amplifier duty cycles.

4-1.3 It is clear that the radio set is used primarily as a receiver. One possible mission reflecting this kind of usage is air traffic control. Failure reports also clearly indicate that link data is being transmitted and received on the radio sets. Since link data requires a higher level of system performance than does voice, many system degradation problems are first evidenced by failure to support link data traffic.

4-1.4 Maintenance is by removal/replacement of major assemblies ("slices"). This is normally accomplished by radio room personnel aided by built-in test equipment (BITE) and status alarms. In at least one installation the radio set was installed in a non-air conditioned area (hanger deck) where it was subjected to high humidity and moisture.

4-2 MODEL DESCRIPTION

4-2.1 The Reliability Block Diagram for the AN/URC-85 (see Appendix 4A) takes into account the several operating modes of the system. The block representations progress from Figure 4-A.1, the Mode Model, through Figure 4-A.8, the detail of the Antenna Group. According to this model, six different probabilities must be specified to determine the reliability of the radio set during a specific mission. Using the information tabulated in Table 4-A.1, which was obtained from the Final Reliability Prediction Report for the UHF Radio Set AN/URC-85, data item C016 for contract number N00039-73-C-0293, dated 22 February 1977, a reliability engineer can calculate the expected MTBF's for different mission lengths and profiles.

4-2.2 A computer program in BASIC, a standard computer language, has been written to implement this model (see listing in Figure 4-A.9). The radio set is assumed to follow the behavior of common electronic assemblies, that is, the exponential failure distribution. An example run is shown in Figure 4-A.10.

SECTION V - PROBLEMS

5-1 Most failures in the AN/URC-85 Radio Sets have occurred in random fashion; therefore, no corrective action is required. However, one recurrent failure has been traced to Amplifier-Modulator AM-6148/ARC-138(V) of Radio Set AN/URC-82A. A PA (power amplifier) tube has repeatedly failed, and although this failure is commensurate with life cycle expectations and is not a design weakness, the entire module must be sent to the depot for repairs.

SECTION VI. CORRECTIVE ACTIONS

6-1 The feasibility of making the PA tube a part of the ship's spare inventory is being investigated and, if results are favorable, the procedure will be published as a maintenance hint in the EIB (Electronics Information Bulletin). Providing the tube as a ship's spare would not affect the reliability factor, but is recommended because it will improve maintainability.

SECTION VII. COST-BENEFIT

7-1 The cost of studying the situation and writing the EIB would be approximately \$3,000. This includes applying for an FSN (Federal Stock Number) for the tube, studying replacement and alignment procedures, and determining whether a technician can perform the tasks with equipment generally available on board. If instituted, this procedure would eliminate the expense of shipping the entire module to and from the depot, and would significantly reduce the cost of depot repairs.

SECTION VIII. SPECIFICATION REQUIREMENTS

8-1 RELIABILITY

8-1.1 OPERATIONAL STABILITY. The contract specifications require the equipment to operate with satisfactory performance continuously or intermittently, for a period of at least 1000 hours without the necessity for readjustment of any controls not accessible to the operator during normal use.

8-1.2 OPERATING LIFE. The equipment shall have a total operating life of not less than 45,000 hours with reasonable servicing and replacement of parts. Parts requiring scheduled replacement shall be specified by the contractor.

8-1.3 QUANTITATIVE RELIABILITY. The specified MTBF of this equipment, θ_0 as defined by MIL-STD-781, shall be 500 hours.

8-2 MAINTAINABILITY

8-2.1 QUALITATIVE MAINTAINABILITY. The equipment and repairable assemblies shall be constructed to provide ease of maintenance, accessibility, and replacement of those items that are replaced during maintenance tasks. Ease of maintenance, troubleshooting and repair shall be a primary design consideration.

8-2.2 INTERCHANGEABILITY. Mechanical and electrical interchangeability shall exist between identical assemblies, subassemblies, and replaceable parts. In the design of the equipment, provisions shall be made for design tolerance to accommodate various solid-state components such as microcircuits and other parts having the limiting dimensions and characteristics set forth in the specifications for the particular part involved without departure from the specified performance.

8-2.3 QUANTITATIVE MAINTAINABILITY. The equipment shall have an MTTR of 2.0 hours. The MTTR includes localization, isolation, disassembly, interchange, reassembly, alignment and checkout for all maintenance tasks performed at the organizational level of maintenance.

8-3 ACCESSIBILITY

8-3.1 The arrangement of parts shall be such that replacement or adjustment of any part is possible without removal of or damage to adjacent parts. All parts shall be readily accessible for replacement or repair with chassis withdrawn or access doors open.

SECTION IX - FLEET DATA ANALYSIS

9-1 DATA COLLECTION.

9-1.1 Data in the FRAP field study was collected by interviews with operating and maintenance personnel and by mail in the form of copies of 3M's OPNAV 4790/2K forms using preaddressed envelopes. To allow parametric analysis, FRAP Elapsed Time Meter (ETM) packages were installed on sample platforms. FRAP AN/URC-85 users were instructed to include the ETM readings on each submission. Numerical data was encoded, keypunched, and statistically reduced using electronic computers. Data from interviews, narrative comments on the 3M forms, and information from failure analysis was used by FRAP reliability engineers to correlate, interpret and, sometimes, correct data submitted by the Fleet.

9-2 SUMMARY OF COMPUTER ANALYSIS.

The output of the computer run is contained in Appendix 4B. Reliability, maintainability, and availability (RM&A) parameters have been extracted and listed in Table 4-9.1 below:

TABLE 4-9.1

Parameter	AN/URC-85
MTBF	1489 hours
Not Greater Than	2676 hours
Not Less Than	886 hours
Failures Observed	7
Verification Ratio	0.95
Est. Equipment MTBF	1567 hours
Not Greater Than	2817 hours
MTTR	4.0 hours
Not Less Than	1.53 hours
Typical Mission	60 days
Mission Duty Cycle	0.485
Mission Completed Without Repair	63%
Availability	0.96

9-2.1 **PARAMETERS.** Statistical estimates of MTBF and MTTR are given above with appropriate confidence limits calculated at the 90% level. The failure distribution is exponential and the repair time distribution is log-normal. This is the expected situation.

9-2.2 **PROBLEM AREAS.** No significant problems were identified.

SECTION X - DEPOT DATA ANALYSIS

10-1 METHODS.

10-1.1 DATA COLLECTION. The Naval Electronics Systems Test and Evaluation Detachment (NESTED) located near St. Mary's City, MD is Field Maintenance Agent (FMA) for the AN/URC-85 and as such has maintained a record of depot returns since initial deployment. The first entry listed is in May 1975, and the last listed is February 1977. This record was tabulated by slice in preparation for statistical analysis. A total of 133 failures were tabulated with 5 being classified as "other", i.e., not fitting into any of the slice classifications.

10-1.2 STRUCTURED ANALYSIS. FRAP has developed a failure ranking technique useful for locating field problems as evidenced by their module return rates. This method takes into account both the numbers of each module used in a system and the complexity of each module. A problem is evidenced by an observed return rate which is significantly larger than the expected return rate. To measure this significance, a Poisson Test of Means is used. The results of this test are expressed in percent and represent the probability that the observed return rates and the expected return rates are truly different, i.e., the resultant value approaches 100% significance if the two rates differ by more than the random error of sampling can account for. In FRAP, 95% significance was chosen as the trigger point for follow-up study.

10-1.3 VERIFICATION RATIO. For each of the 95% + significant slices, a verification ratio was calculated using:

$$V = (N1 + N2/2)/N$$

where:

N1 = Number of failures confirmed at depot repair.

N2 = Number of unconfirmed failures.

N3 = N1 + N2 = Total number of failures.

This equation states that it is an even chance that an unconfirmed failure did, in fact, malfunction in the Fleet. Verification ratios range between 0.50 and 1.00 with 0.85-0.90 being average. High verification ratios tend to indicate easily located problems such as catastrophic failures, while low verification ratios tend to indicate the presence of some unusual factor such as thermal problems, training or technical manual shortcomings, or problems in test procedures.

10-2 FINDINGS.

10-2.1 The results of statistical analysis are shown in Table 4-10.1. Two slices were found to be significant problems. These two slices account for 39% of all depot returns. A potential 35% increase in overall system MTBF would be achieved by bringing both slices up to their predicted MTBF.

10-2.2 AMPLIFIER/MODULATOR. The amplifier/modulator, slice 1A7A2, is 100% significant on 35 returns with a verification ratio of 1.00. The electron tube designated V1 was replaced in 14 of these returns, although multipart failures were the rule. This tube, Power Amplifier (A8) part number 256-0182-0/0, appears to be performing up to expectations and is not a materials problem. Placing this tube in the ships ready replacement stock would reduce the depot return rate, but not enough to lower the significance from 100%. No other pattern is apparent.

10-2.3 1 KW POWER AMPLIFIER. The high power amplifier, slice designator 1A9A2, is a linear 1 KW unit switchable into either one of the two AN/URC-85 transmit channels. It shows 100% significance on 17 returns with a verification ratio of 0.97. There were six replacements of the printed circuit board designated "A7". No pattern is apparent.

AM/URC-85 DEPOT DATA ANALYSIS

Designator	Nomenclature	Number Used	Failure Rate In %/1K Hrs	Number Failed	Number Expected	Poisson Significance
1	1A1 Cabinet	1	15.386	4	2.35	78.98%
2	2A1 Cabinet-Filters	1	10.000	0	-----	-----
3	1A6 Indicator Panel	1	17.692	2	2.7	24.9
4	1A2 Control Box	4	13.029	12	12	89.18
5	1A7A3 Control Synthesizer	4	61.126	15	37.29	--0--
6	1A7A5 I.F. Amp	2	24.802	4	7.57	5.67
7	1A7A6 Receiver Translator	2	21.877	6	6.67	34.44
8	1A7A2 Amp/Modulator	2	40.323	35	12.3	100*
9	2A3A2 Band Pass Filter	2	60.088	14	18.33	12.66
10	2A2A2 Band Pass Filter	2	60.099	9	18.33	0.58
11	1A9A3 Power Supply	1	69.307	9	10.57	27.24
12	1A9A2 Power Amplifier	1	32.709	17	4.99	100*
13	2A3A1 Combining Network	2	2.000	1	0.31	73.71
14	----- T/R Antenna	2	<u>2.000</u>	0	-----	-----
Predicted MTBF = 114.67 hours			Total =	872.07	5 "other"	

133 Total Failed

TABLE 4-10.1

APPENDIX 4A

RELIABILITY MODEL FOR THE AN/URC-85

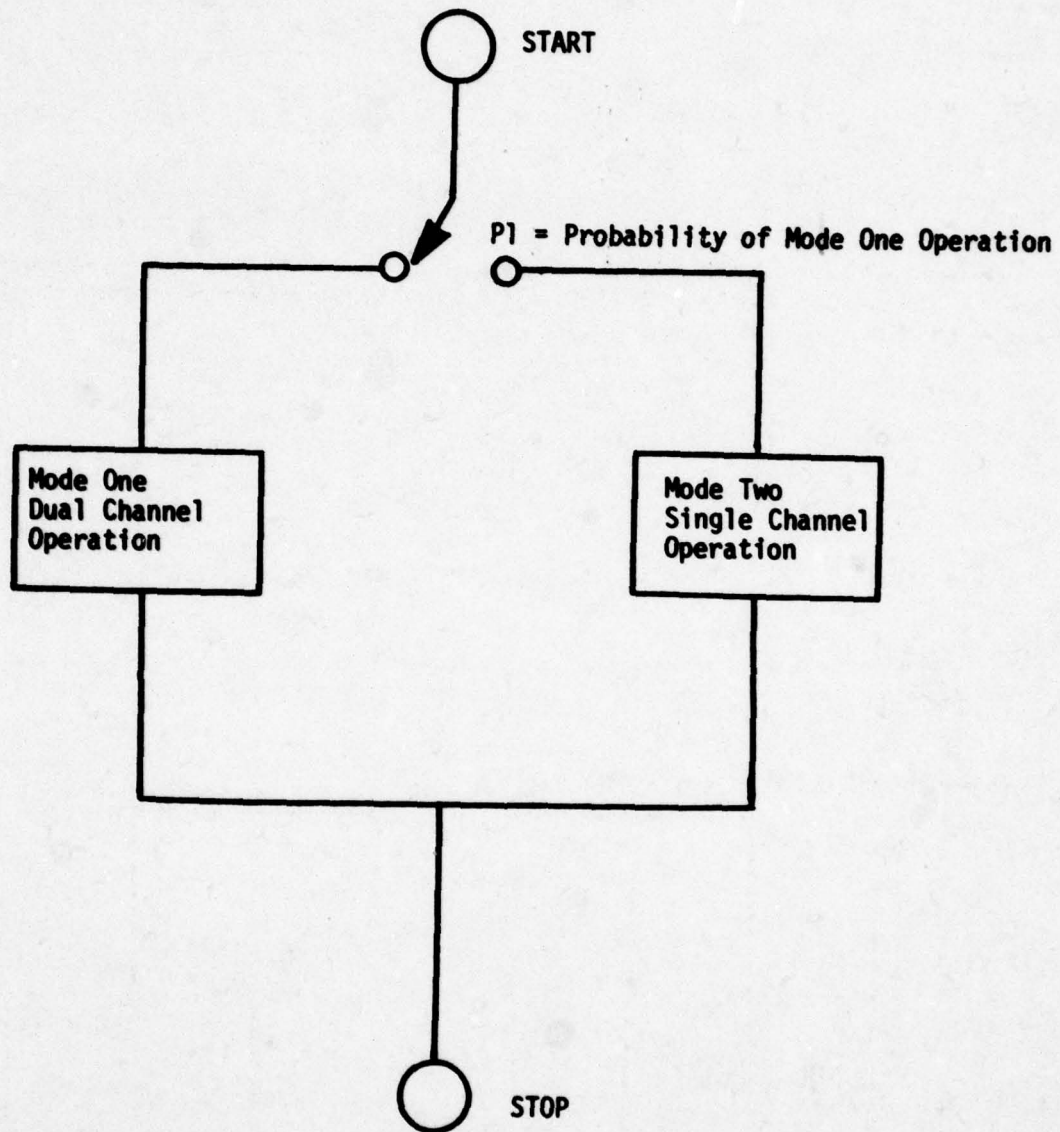

AN/URC-85
Mode Model
Figure 4-A.1

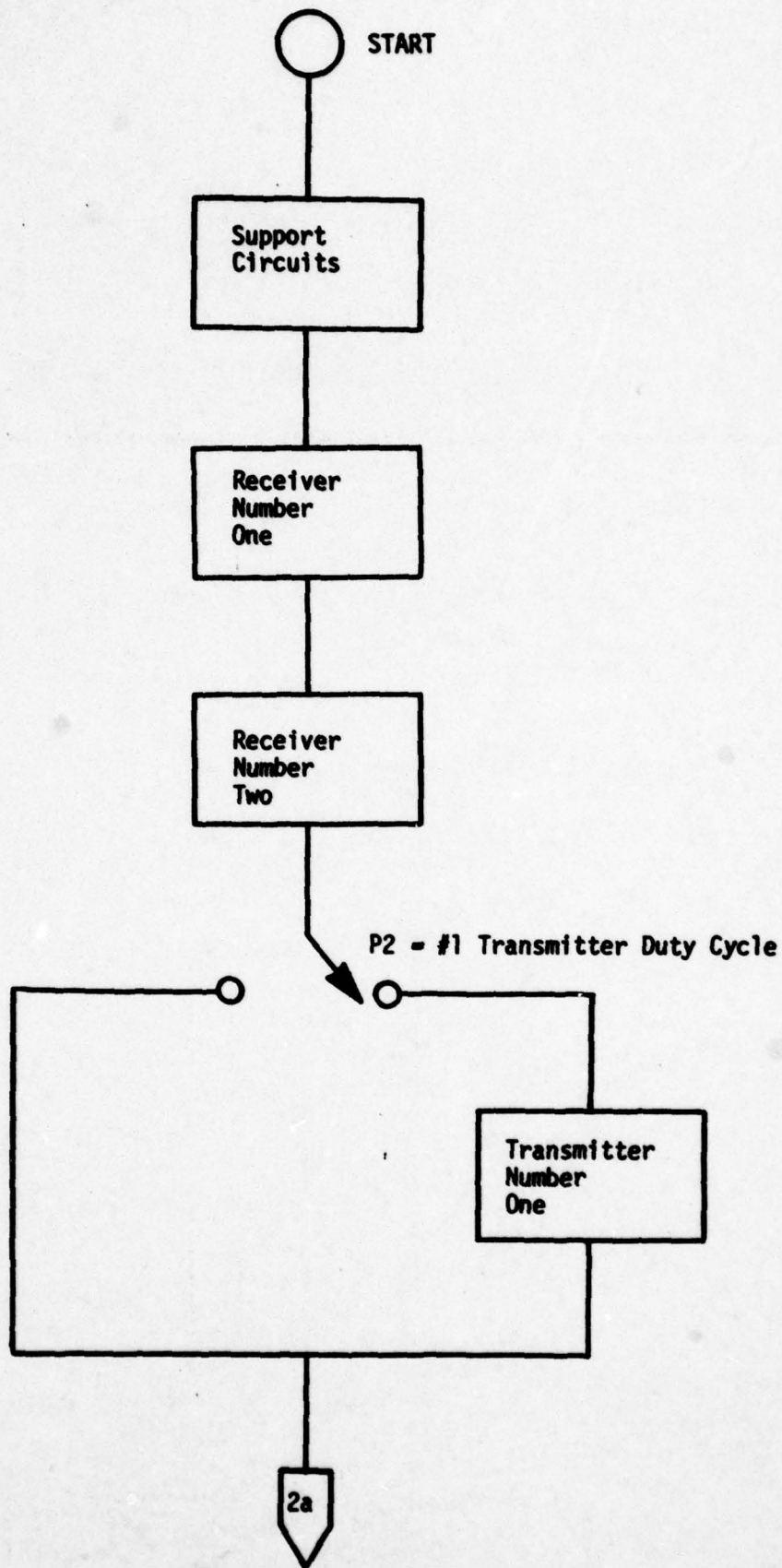

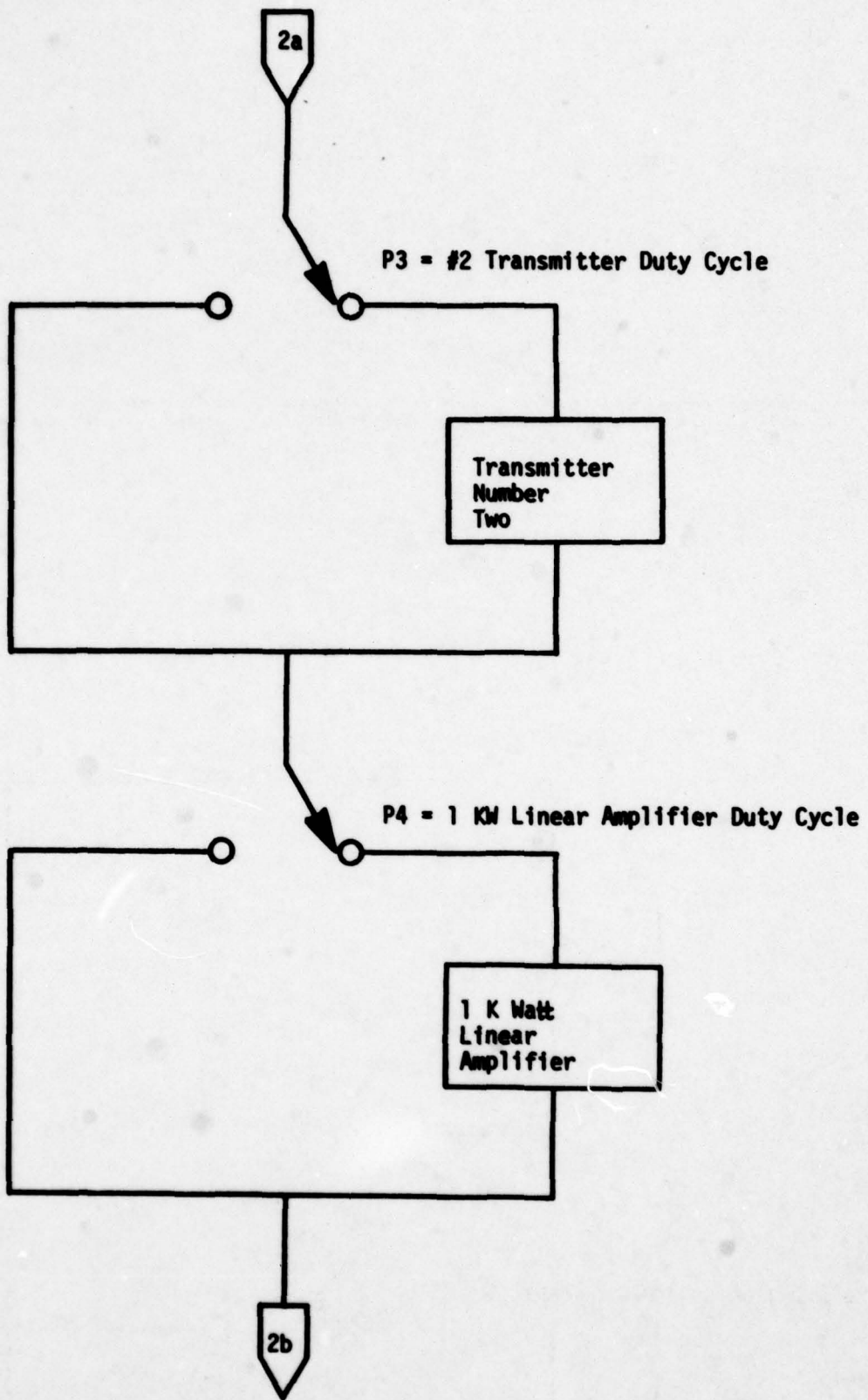

Figure 4-A.2 (Continued)

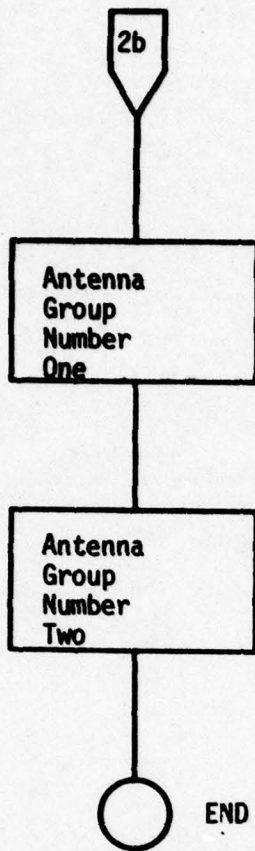
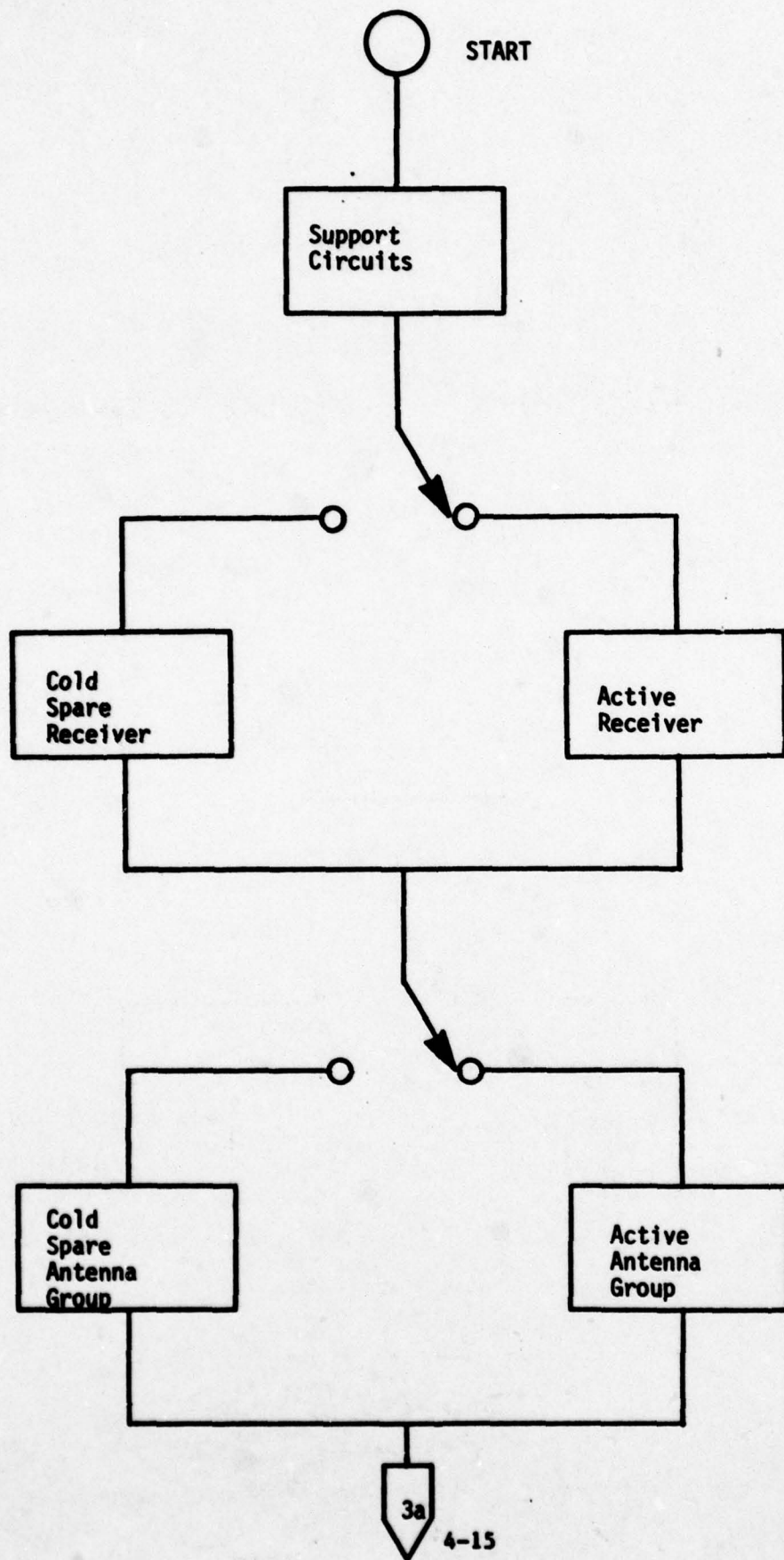
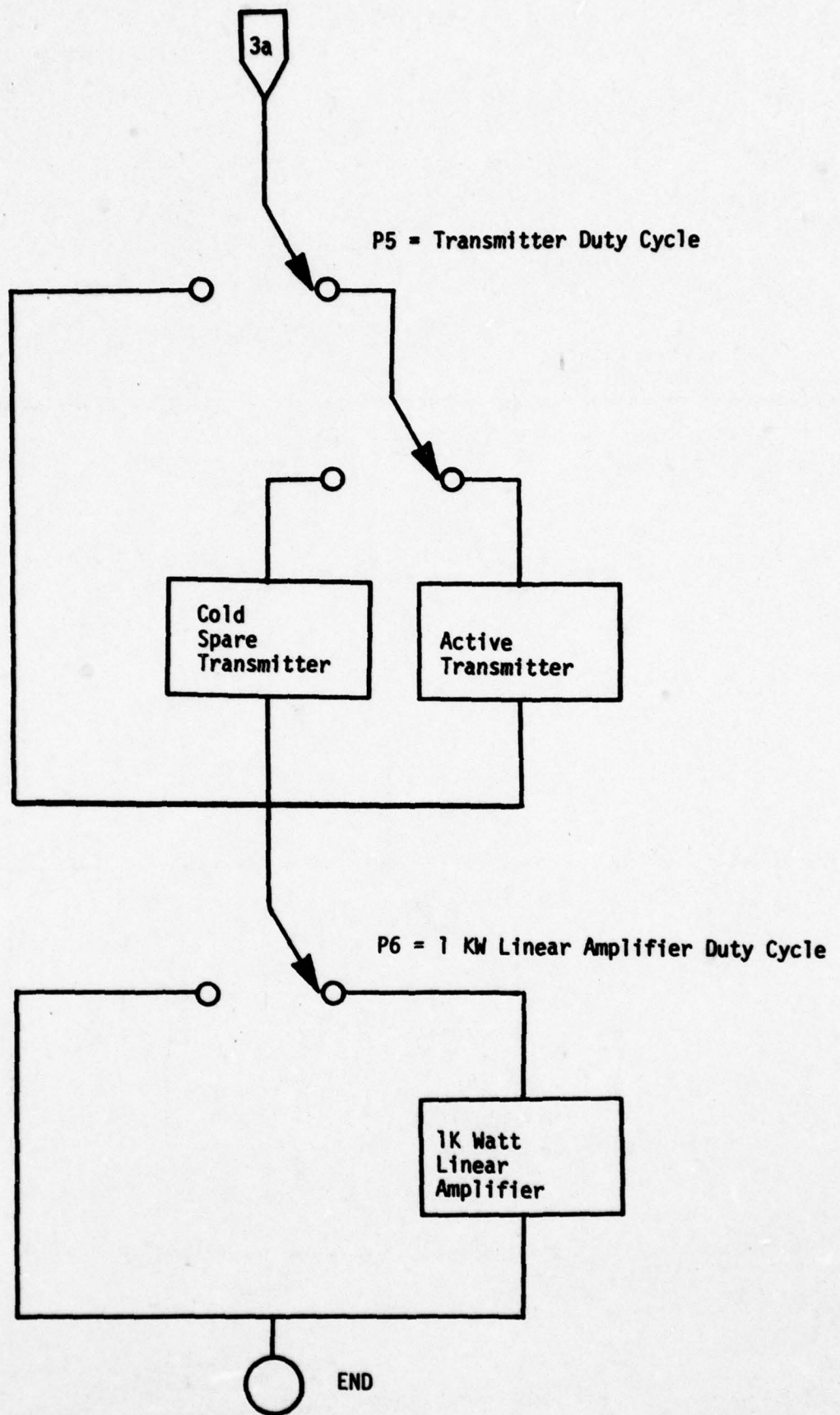
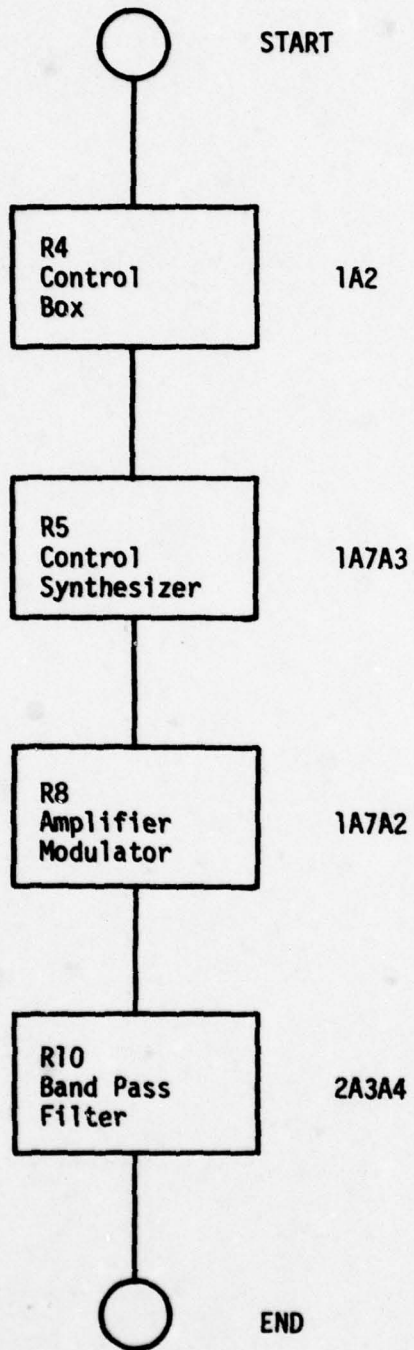

Figure 4-A.2 (Continued)



Mode Two
Single Channel Operation
Figure 4-A.3





Transmitter
Figure 4-A.4

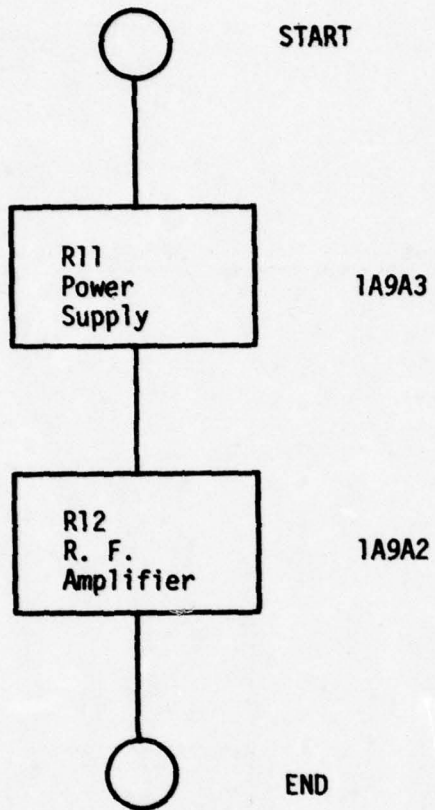

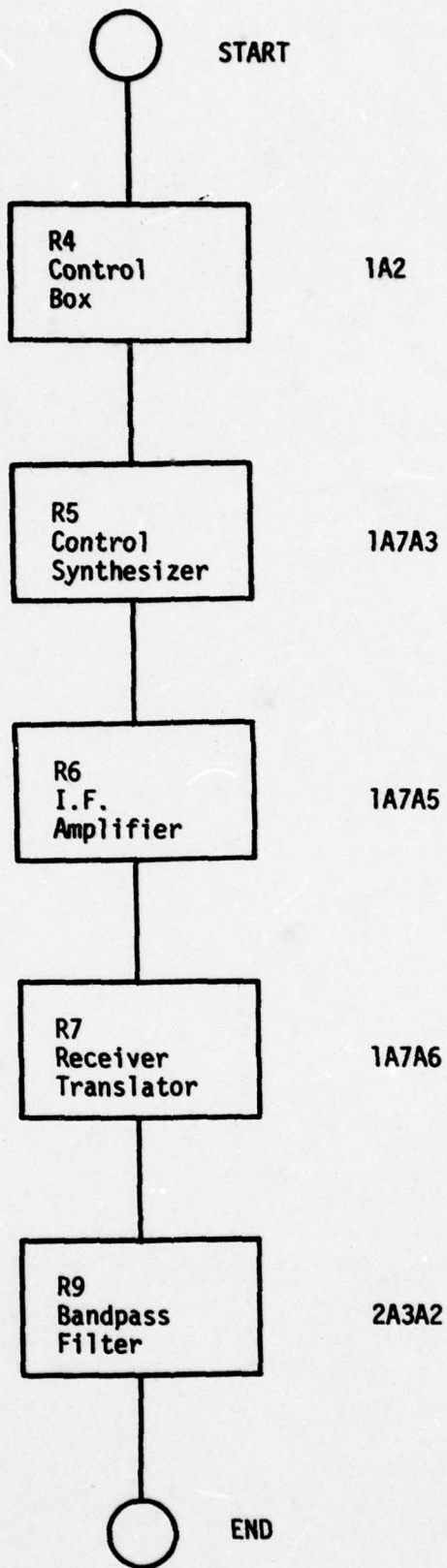

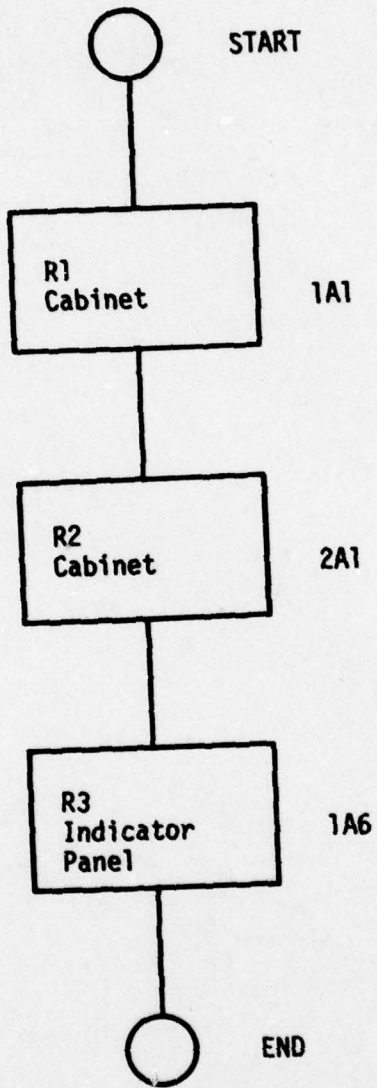

Support Circuits
Figure 4-A.7

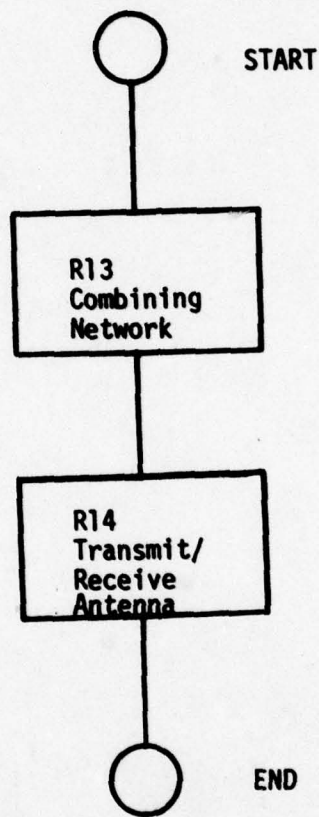

**Table 4-A.1
DATA SHEET FOR AN/URC-85 MODEL**

Reference Number	Nomenclature of SLICE	Number Used	Failure Rate (%/1000 hrs)
R1	Cabinet	1	15.386
R2	Cabinet	1	10.000
R3	Indicator Panel	1	17.692
R4	Control Box	4	13.029
R5	Control Synthesizer	4	61.126
R6	I.F. Amplifier	2	24.802
R7	Receiver Translator	2	21.877
R8	Amplifier/Modulator	2	40.323
R9	Band Pass Filter	2	60.088
R10	Band Pass Filter	2	60.088
R11	Power Supply	1	69.307
R12	Linear RF Amplifier	1	32.709
R13	Combining Network	2	2.000
R14	Antenna	2	2.000

NOTE:

System MTBF and Failure Rate depends on operating mode and transmitter duty cycle. See computer program.

LIST

77/09/23. 11.19.52.
PROGRAM URC05

```

100 REM MODEL FOR AN/URC-85
00110 PRINT"INPUT MISSION LENGTH IN HOURS = "1//INPUT T
00120 PRINT
00130 PRINT"EXPRESS THE FOLLOWING PARAMETERS AS PERCENTAGES:"
00140 PRINT
00150 PRINT"INPUT PROBABILITY OF DUAL CHANNEL OPERATION = "1//INPUT P1
00160 PRINT"INPUT TRANSMITTER NUMBER ONE DUTY CYCLE (IN MODE ONE) = "1
00170 INPUT P2
00180 PRINT"INPUT TRANSMITTER NUMBER TWO DUTY CYCLE (IN MODE ONE) = "1
00190 INPUT P3
00200 PRINT"INPUT 1KW LINEAR POWER AMP DUTY CYCLE (IN MODE ONE) = "1
00210 INPUT P4
00220 PRINT"INPUT TRANSMITTER DUTY CYCLE (IN MODE TWO) = "1
00230 INPUT P5
00240 PRINT"INPUT 1KW LINEAR POWER AMP DUTY CYCLE (IN MODE TWO) = "1
00250 INPUT P6
00260 REM CONVERT PERCENTAGES TO DECIMALS
00270 P1=P1/100
00280 P2=P2/100
00290 P3=P3/100
00300 P4=P4/100
00310 P5=P5/100
00320 P6=P6/100
00330 P7=1-P1 'CALC. PROB. MODE 2 DPS
00340 RESTORE
00350 DIM R(14)
00360 REM READ IN FAILURE RATE DATA
00370 FOR I=1 TO 14
00380 READ A,R(I)
00390 R(I)=R(I)*1E-5 'CONVERT TO DECIMAL
00400 NEXT I
00410 REM EXPONENTIAL DISTRIBUTION IS ASSUMED
00420 REM RELIABILITY = EXP(-SUM FAILURE RATE*MISSION TIME)
00430 REM SUM FAILURE RATES FOR MAJOR BLOCKS
00440 S0=R(1)+R(2)+R(3) 'SUPPORT CIRCUITS
00450 R1=R2=R(4)+R(5)+R(6)+R(7)+R(9) 'RECEIVERS
00460 T1=T2=R(4)+R(5)+R(8)+R(10) 'TRANSMITTERS
00470 K1=R(11)+R(12) 'LINEAR AMPLIFIER
00480 A1=A2=R(13)+R(14) 'ANTENNA GROUP
00490 REM CALC. MODE ONE (DUAL CHNNL) FAILURE RATE
00500 M1=S0+R1+R2+P2*T1+P3*T2+P4*K1+A1+A2
00510 T3=P1*T 'CALC. TIME IN MODE ONE
00520 X=EXP(-M1*T3) 'CALC. REL. IN MODE ONE
00530 REM CALC. COLD SPARE REDUNDANT RELIABILITY FOR MODE TWO
00540 T4=P7*T 'CALC. TIME IN MODE TWO
00550 Y=EXP(-(S0+P6*K1)*T4)
00560 Y=Y*(1+R1*T4)*EXP(-(R1*T4))
00570 Y=Y*(1+T1*P5*T4)*EXP(-(T1*P5*T4))
00580 Y=Y*(1+A1*T4)*EXP(-(A1*T4))
00590 REM CALC. OVERALL MISSION RELIABILITY
00600 Z=X*Y
00610 PRINT
00620 PRINT"MISSION RELIABILITY:"
00630 PRINT"MODE ONE", "MODE TWO", "OVERALL"
00640 X=(INT(X*1000))/1000
00650 Y=(INT(Y*1000))/1000
00660 Z=(INT(Z*1000))/1000
00670 PRINT X*Y*Z
00680 PRINT
00690 STOP
00700 REM R= FAILURE RATE (IN %/1000 HOURS)
00710 DATA 1, 15.386
00720 DATA 2, 10.000
00730 DATA 3, 17.692
00740 DATA 4, 13.029
00750 DATA 5, 61.126
00760 DATA 6, 24.802
00770 DATA 7, 21.877
00780 DATA 8, 40.323
00790 DATA 9, 60.088
00800 DATA 10, 60.088
00810 DATA 11, 69.307
00820 DATA 12, 32.709
00830 DATA 13, 2.000
00840 DATA 14, 2.000
READY.

```

Figure 4-A.9

RUN

77/02/11. 13.50.03.
PROGRAM URC85

INPUT MISSION LENGTH IN HOURS = ? 500

EXPRESS THE FOLLOWING PARAMETERS AS PERCENTAGES

INPUT PROBABILITY OF DUAL CHANNEL OPERATION = ? 50
INPUT TRANSMITTER NUMBER ONE DUTY CYCLE (IN MODE ONE) = ? 25
INPUT TRANSMITTER NUMBER TWO DUTY CYCLE (IN MODE ONE) = ? 15
INPUT 1KW LINEAR POWER AMP DUTY CYCLE (IN MODE ONE) = ? 2
INPUT TRANSMITTER DUTY CYCLE (IN MODE TWO) = ? 10
INPUT 1KW LINEAR POWER AMP DUTY CYCLE (IN MODE TWO) = ? 2

MISSION RELIABILITY		
MODE ONE	MODE TWO	OVERALL
.297	.824	.245

SBU 0.317 UNTS.

RUN COMPLETE.

APPENDIX 4B

COMPUTER ANALYSIS OF FLEET FAILURE DATA FOR THE AN/URC-85

CUMULATIVE OBSERVED DISTRIBUTION VERSUS THEORETICAL
EXPONENTIAL PROBABILITY DISTRIBUTION FOR TIME TO FAILURE

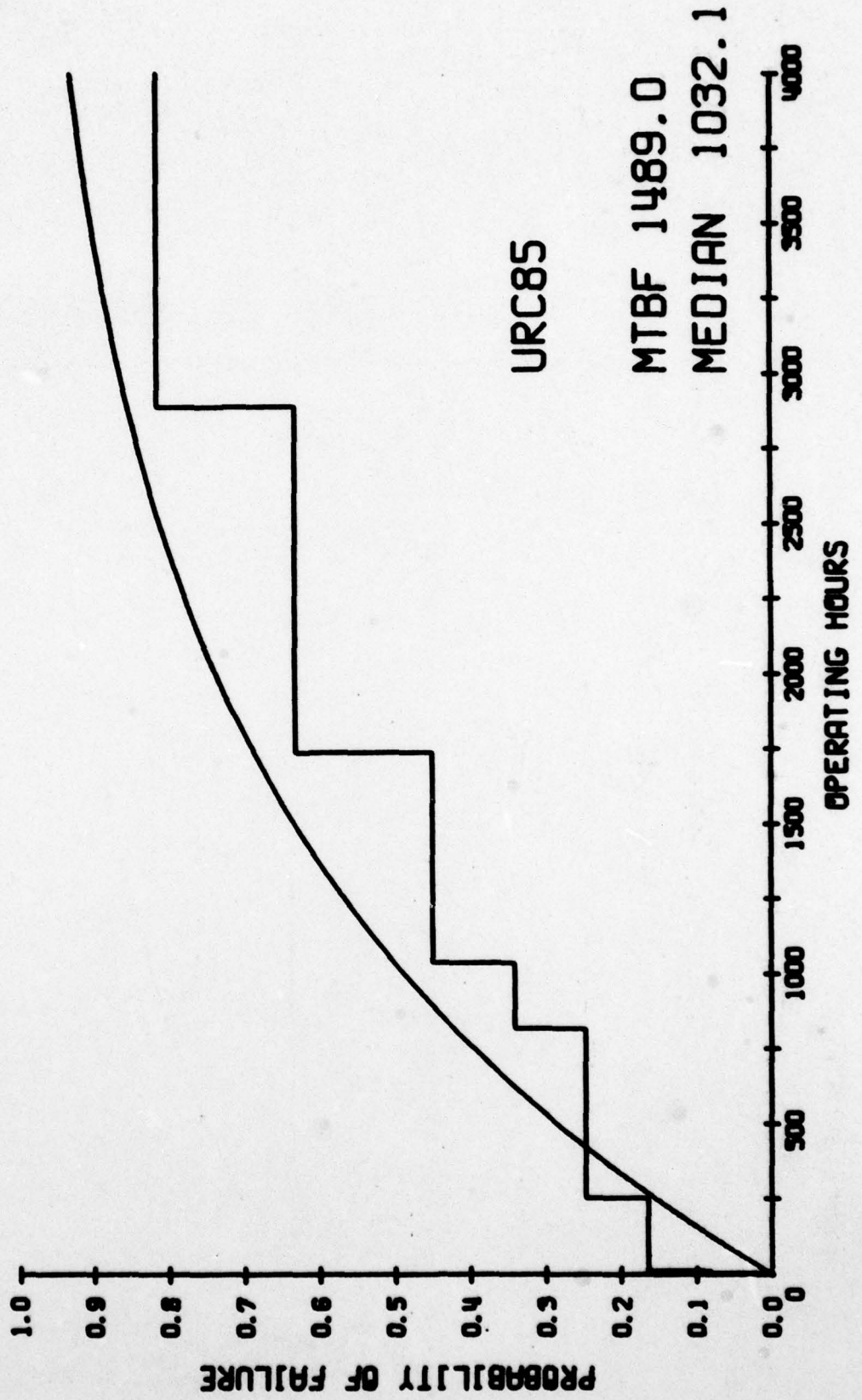

R E L I A B I L I T Y
SYSTEM LEVEL

TIME TO FAIL	NO. FAILURES	NO. CENSORED	SURVIVORS	CPDF	EXPONENTIAL	MAX DIFFERENCE
6.1	1.		11.	.083	.004	.079
13.9	1.		10.	.167	.009	.157
258.7	1.		9.	.250	.159	.091
400.7		1.				
821.9	1.		7.	.344	.424	.174
909.1		1.				
1042.6	1.		5.	.453	.504	.160
1102.2		1.				
1236.1		1.				
1739.2	1.		2.	.635	.689	.236
2892.7	1.		1.	.818	.857	.221

EQUIPMENT OPERATING HOURS (O.H.) = 10423.2 CALENDAR HOURS (C.H.) = 21504.0 DUTY CYCLE (D.H./C.H.) = .485

NUMBER OF FAILURES = 7. OBSERVED FAILURE RATE/D.H. = .67198E-03

DISTRIBUTION DETERMINATION,

K-S CRITICAL VALUE (.10, 7.) = .350

MAX DIFF CALC = .236, IS LESS THAN CRITICAL VALUE THEREFORE THE EXPONENTIAL DISTRIBUTION IS ASSUMED FOR THE ASSUMED DISTRIBUTION

EST. MEAN = 1489.029, EST. MEDIAN = 1032.116, 90 PER CENT LCL FOR MEAN = 885.5, 90 PER CENT UCL FOR MEAN = 2676.208

90 PERCENT UCL 2676.21 IS GREATER THAN 500.00 HOURS, THEREFORE THE EQUIPMENT MEETS THE SPECIFICATIONS

R E L I A B I L I T Y

URC85 D-LEVEL SUMMARY

WRA	D-LEVEL BLOCK NO.	D-LEVEL NOMENCLATURE	NUMBER FAILURES	LOWER 90 CONF LIM	MEAN	UPPER 90 CONF LIM	SPEC MTBF	OBSERVED FAILURE TIMES LOW	OBSERVED FAILURE TIMES HIGH	RELIAB PROBLEM
1	1	CABINET	1.	2679,68	10423,20	98929,38	6500,00	258,70	258,70	NO
1	5	CONTROL SYNTHESIZER	1.	2679,68	10423,20	98929,38	1636,00	272,60	272,60	NO
1	8	AMPLIFIER/MODULATOR	2.	1958,40	5211,60	19599,43	2480,00	1739,20	2892,70	NO
1	9	HAND PASS FILTER	1.	2679,68	10423,20	98929,38	1664,00	1094,50	1094,50	NO
1	10	RAID PASS FILTER	1.	2679,68	10423,20	98929,38	1664,00	2781,80	2781,80	NO
1	11	POWER SUPPLY	1.	2679,68	10423,20	98929,38	1443,00	2898,80	2898,80	NO
1	12	K F AMPLIFIER	1.	2679,68	10423,20	98929,38	3057,00	2898,80	2898,80	NO

R E L I A B I L I T Y

2K SUMMARY FOR URC85 PROBLEM AREAS

SYSTEM WRA O-L O-L O-L SYSTEM SYMPTON DIAGNOSTIC RESULTS

JCH

CUMULATIVE OBSERVED DISTRIBUTION VERSUS THEORETICAL LOGNORMAL PROBABILITY DISTRIBUTION FOR TIME TO REPAIR

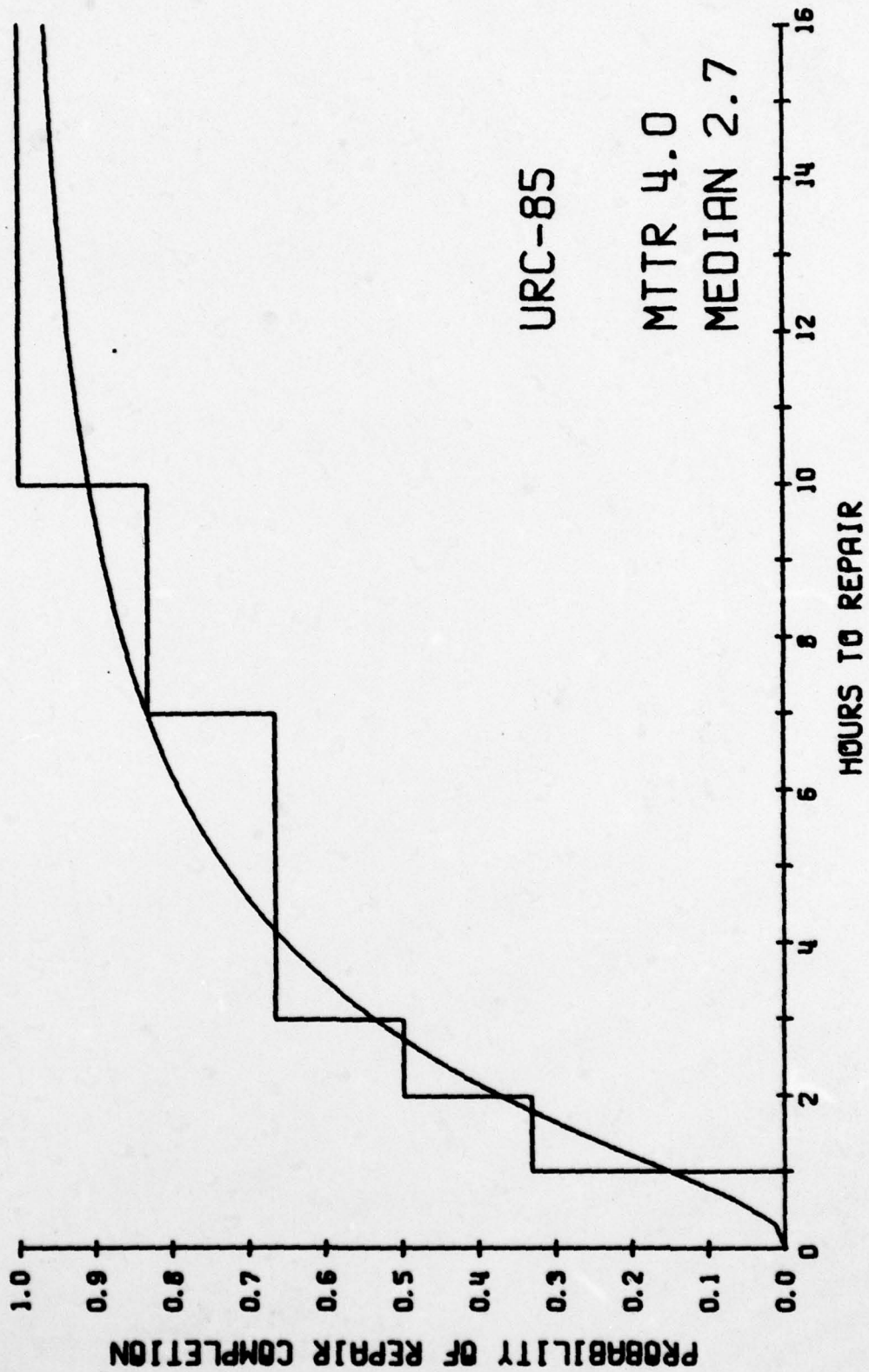

FLEET MAINTAINABILITY ASSESSMENT DATA

WRA	DL1	DL2	DL3	DISCOVERY DATE	COMPLETION DATE	DOWN TIME (HRS)	REPAIR TIME (HRS)	SYS	UIC
1	1	0	0	6272	6273	24.0	10.0	9	03364
1	5	0	0	6274	6274	1.0	1.0	9	03364
1	9	0	0	6345	6346	24.0	2.0	9	03364
1	999	0	0	6239	6240	24.0	0.0	9	03365
				N1 REPAIR TIME FOR THE ABOVE RECORD					
1	8	0	0	6350	6350	0.0	0.0	9	03365
				N2 REPAIR TIME FOR THE ABOVE RECORD					
1	10	0	0	7047	7061	336.0	7.0	9	03367
1	8	0	0	6319	6319	1.0	1.0	9	03367
1	11	12	0	6336	6337	24.0	3.0	9	03367

MAINTAINABILITY (REPAIR TIME)

REPAIR TIME	FREQUENCY	CUM. FREQUENCY	NPF	LOGNORMAL	MAX DIFFERENCE
1.0	2.	2.0	.286	.149	.136
2.0	1.	3.0	.429	.273	.087
3.0	1.	4.0	.571	.338	.109
7.0	1.	5.0	.714	.834	.262
10.0	1.	6.0	.857	.909	.195

TOTAL REPAIR HOURS = 24.0 NUMBER OF REPAIRS = 6. OBSERVED REPAIR RATE/HR = .2500E+00

DISTRIBUTION DETERMINATION

MEAN OF LN'S = 1.01 STD DEV OF LN'S = .97

K-S CRITICAL VALUE (.10, 6.) = .294 MAX DIFF CALC = .262 IS LESS THAN THE CRITICAL VALUE

THEREFORE THE LOGNORMAL DISTRIBUTION IS ASSUMED

EST MEAN = 4.00 EST MEDIAN = 2.74 90 PER CENT LCL ON MEDIAN = 1.53 90 PER CENT UCL ON MEDIAN = 4.91

SPECIFIED MTRR = 2.00 HOURS LOWER CONF LIM 1.53 IS LESS THAN MTRR, THUS THE EQUIPMENT MEETS THE SPECIFICATIONS

MAINTAINABILITY (DOWN TIME)

URC-85 SYSTEM LEVEL

DOWN TIME	FREQUENCY	CUM FREQUENCY	NPF	LOGNORMAL	MAX DIFFERENCE
1.0	2.	2.0	.286	.126	.160
24.0	3.	5.0	.714	.609	.324
336.0	1.	6.0	.857	.928	.214

TOTAL DOWN TIME (TDT) = 434.0 NUMBER OF REPAIRS (NR) = 6. OBSERVED DOWN TIME/REPAIR (TDT/NR) = 72.33

DISTRIBUTION DETERMINATION

MEAN OF LN'S = 2.56 STD DEV OF LN'S = 2.23

LESS THAN FOUR DISTINCT REPAIR TIMES

THEREFORE THE LOGNORMAL DISTRIBUTION IS ASSUMED

EST MEAN = 72.33 EST MEDIAN = 12.92 90 PER CENT LCL ON MEDIAN = 3.37 90 PER CENT UCL ON MEDIAN = 49.51

MAINTAINABILITY (REPAIR TIME)

URC-65 O-LEVEL SUMMARY

WPA	O-LEVEL BLOCK NO.	O-LEVEL NOMENCLATURE	NUMBER REPAIRS	LOWER 90 CONF LIM	UPPER 90 CONF LIM	SPEC MTR	OBSERVED REPAIR TIMES LOW	MEAN	HIGH	MAINT PROBLEM
1	1	CABINET	1.	NO CONF LIMITS		2.0	10.0	10.00	10.0	
1	5	CONTROL SYNTHESIZER	1.	NO CONF LIMITS		2.0	1.0	1.00	1.0	
1	8	AMPLIFIER/MODULATOR	1.	NO CONF LIMITS		2.0	1.0	1.00	1.0	
1	9	BAND PASS FILTER	1.	NO CONF LIMITS		2.0	2.0	2.00	2.0	
1	10	BAND PASS FILTER	1.	NO CONF LIMITS		2.0	7.0	7.00	7.0	
1	11	POWER SUPPLY	1.	NO CONF LIMITS		2.0	3.0	3.00	3.0	
1	12	R F AMPLIFIER	1.	NO CONF LIMITS		2.0	3.0	0.00	3.0	

MAINTAINABILITY (REPAIR TIME)
2K SUMMARY FOR URC-85 PROBLEM AREAS

JCN WRA 0-L 0-L 0-L SYSTEM SYMPTON DIAGNOSTIC RESULTS

RMA SUMMARY URC-85 EXC SYSTEM LEVEL

TTF DISTRIBUTION IS EXPONENTIAL WITH MEAN = 1489.03
DT DISTRIBUTION IS LOGNORMAL WITH MEAN OF LNS = 2.56000 AND STANDARD DEVIATION OF LNS = 2.23000
RT DISTRIBUTION IS LOGNORMAL WITH MEAN OF LNS = 1.01000 AND STANDARD DEVIATION OF LNS = .97000

INHERENT AVAILABILITY = $MTRF / (MTBF \cdot MTRR)$

MEAN TIME TO FAILURE = 1489.03

MEAN REPAIR TIME = 4.31

INHERENT AVAILABILITY = .9971

OBSERVED AVAILABILITY (SIMULATION OF RATIOS TTF/(TTF+DT))

90 PERCENT LCL ON INDIVIDUALS = .6743

90 PERCENT UCL ON INDIVIDUALS = .9964

MEAN = .9027

MEDIAN = .9818