

AD-A068 927

BENDIX CORP DAVENPORT IOWA INSTRUMENTS AND LIFE SUPP--ETC F/G 6/11  
ANTI-SUFFOCATION VALVE BENDIX TYPE NUMBER 3267010-0101.(U)  
APR 79 J MIENTUS, R CRAMER, J DUNBAR N62269-76-C-0214

UNCLASSIFIED

NADC-79010-60

NL

| OF |

AD  
A068927



END  
DATE  
FILMED  
7-79  
DDC

REPORT NO. NADC-79010-60

**LEVEL II**

12  
B.S.



**ANTI-SUFFOCATION VALVE  
BENDIX TYPE NO. 3267010-0101**

J. Mentus, R. Cramer and J. Dunbar  
The Bendix Corporation  
Instruments and Life Support Division  
Davenport, Iowa 52808

and

Matthew Lamb and Richard Routzahn  
Aircraft and Crew Systems Technology Directorate  
NAVAL AIR DEVELOPMENT CENTER  
Warminster, Pennsylvania 18974

16 APRIL 1979

FINAL REPORT  
AIRTASK NO. WF41-451-401  
Work Unit No. DS 903

DDC  
RECEIVED  
MAY 24 1979  
C

APPROVED FOR PUBLIC RELEASE; DISTRIBUTION UNLIMITED

Prepared for  
NAVAL AIR SYSTEMS COMMAND  
Department of the Navy  
Washington, D.C. 20361

79 05 18 124

AD A068927

DDC FILE COPY

## NOTICES

**REPORT NUMBERING SYSTEM** - The numbering of technical project reports issued by the Naval Air Development Center is arranged for specific identification purposes. Each number consists of the Center acronym, the calendar year in which the number was assigned, the sequence number of the report within the specific calendar year, and the official 2-digit correspondence code of the Command Office or the Functional Directorate responsible for the report. For example: Report No. NADC-78015-20 indicates the fifteenth Center report for the year 1978, and prepared by the Systems Directorate. The numerical codes are as follows:

| CODE | OFFICE OR DIRECTORATE                             |
|------|---|
| 00   | Commander, Naval Air Development Center           |
| 01   | Technical Director, Naval Air Development Center  |
| 02   | Comptroller                                       |
| 10   | Directorate Command Projects                      |
| 20   | Systems Directorate                               |
| 30   | Sensors & Avionics Technology Directorate         |
| 40   | Communication & Navigation Technology Directorate |
| 50   | Software Computer Directorate                     |
| 60   | Aircraft & Crew Systems Technology Directorate    |
| 70   | Planning Assessment Resources                     |
| 80   | Engineering Support Group                         |

**PRODUCT ENDORSEMENT** - The discussion or instructions concerning commercial products herein do not constitute an endorsement by the Government nor do they convey or imply the license or right to use such products.

APPROVED BY:

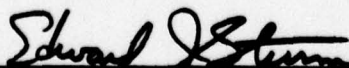

E. J. STUM  
CDR USN

DATE: 4-16-79

UNCLASSIFIED

SECURITY CLASSIFICATION OF THIS PAGE (When Data Entered)

| 19 REPORT DOCUMENTATION PAGE  |   | READ INSTRUCTIONS BEFORE COMPLETING FORM               |                                  |
|---|---|--|----------------------------------|
| 18  | 1. NUMBER (When Assigned)                           | 2. GOVT ACCESSION NO.                                  | 3. RECIPIENT'S CATALOG NUMBER    |
| 6   | 4. TITLE (and Summary)                              | 5. TYPE OF REPORT & PERIOD COVERED                     | 6. PERFORMING ORG. REPORT NUMBER |
|   | ANTI-SUFFOCATION VALVE<br>BENDIX TYPE 3267010-0101. | 9  | Final Report                     |
|   | Number  | 7. AUTHOR(s)   | 8. CONTRACT OR GRANT NUMBER(s)   |
| 10  | J. Mientus, R. Cramer J. Dunbar                     | 15   | NG 2269-76-C-0214                |
| 9. PERFORMING ORGANIZATION NAME AND ADDRESS   |   | 10. PROGRAM ELEMENT, PROJECT, TASK AREA & UNIT NUMBER  |                                  |
| The Bendix Corporation<br>Instruments and Life Support Division<br>Davenport, IA 52808  |   | 17<br>AIRTASK NO. WF41 451 401<br>Work Unit No. DS 903 |                                  |
| 11. CONTROLLING OFFICE NAME AND ADDRESS   |   | 12. REPORT DATE  |                                  |
| Naval Air Systems Command<br>Department of the Navy<br>Washington, DC 23061   |   | 11<br>16 APR 1979                                      |                                  |
| 14. MONITORING AGENCY NAME & ADDRESS (if different from Controlling Office)   |   | 13. NUMBER OF PAGES                                    |                                  |
| Aircraft & Crew Systems Technology Directorate<br>Naval Air Development Center<br>Warminster, PA 18974  |   | 21   |                                  |
|   |   | 18. SECURITY CLASS. (of this report)                   |                                  |
|   |   | UNCLASSIFIED   |                                  |
|   |   | 18a. DECLASSIFICATION/DOWNGRADING SCHEDULE             |                                  |
|   |   | 12 26p.  |                                  |
| 16. DISTRIBUTION STATEMENT (of this Report)   |   |  |                                  |
| APPROVED FOR PUBLIC RELEASE; DISTRIBUTION UNLIMITED.  |   |  |                                  |
| 16 F41451   |   |  |                                  |
| 17. DISTRIBUTION STATEMENT (of the abstract entered in Block 20, if different from Report)  |   |  |                                  |
| 18. SUPPLEMENTARY NOTES   |   |  |                                  |
| 19. KEY WORDS (Continue on reverse side if necessary and identify by block number)  |   |  |                                  |
| Anti-Suffocation  |   |  |                                  |
| 20. ABSTRACT (Continue on reverse side if necessary and identify by block number)   |   |  |                                  |
| The oxygen supply currently located in the RSSK (Rigid Seat Survival Kit) provides the aircrewmember with an emergency source of oxygen in the event of an in-flight failure of the aircraft oxygen system, during parachute descent, or in the event of aircraft ditching. An inherent danger in the system is the suffocation of an unconscious aircrewmember who cannot remove his mask in the event the emergency oxygen supply becomes depleted or is malfunctioning. The protection envelope currently provided the aircrewmember |   |  |                                  |

DD FORM 1 JAN 73 1473

EDITION OF 1 NOV 65 IS OBSOLETE  
S/N 0102-LF-014-6601

UNCLASSIFIED

SECURITY CLASSIFICATION OF THIS PAGE (When Data Entered)

402 959

Sw

**UNCLASSIFIED**

SECURITY CLASSIFICATION OF THIS PAGE (When Data Entered)

20. will be greatly enhanced through the incorporation of an anti-suffocation valve, providing the capability of breathing ambient air when oxygen from the emergency supply is no longer available. The valve overcomes the danger of an aircrewmember unknowingly breathing air during normal in-flight operation, and prevents the entrance of water during an underwater or flotation condition.

ACCESS BY for

White Section   
Blue Section

NTIS  
DOC  
UNANNOUNCED  
JUST IDENTIFIED

BY DISTRIBUTION/AVAILABILITY CODES  
Dist. SPECIAL

A

TABLE OF CONTENTS

|   | Page |
|---|------|
| LIST OF FIGURES . . . . .                       | 1    |
| FORWARD . . . . .                               | 2    |
| 1.0 INTRODUCTION . . . . .                      | 3    |
| 2.0 TECHNICAL DISCUSSION . . . . .              | 3    |
| 2.1 PURPOSE . . . . .                           | 3    |
| 2.2 ADMINISTRATIVE DATA . . . . .               | 3    |
| 2.3 SUMMARY . . . . .                           | 3    |
| 2.4 DESCRIPTION OF SPECIMEN . . . . .           | 4    |
| 2.5 OPERATION . . . . .                         | 4    |
| 3.0 SPECIFICATION . . . . .                     | 8    |
| 3.1 GENERAL . . . . .                           | 8    |
| 3.2 PERFORMANCE . . . . .                       | 11   |
| 3.3 ENVIRONMENTAL CONDITIONS . . . . .          | 12   |
| 3.4 RELIABILITY . . . . .                       | 14   |
| 4.0 PROTOTYPE HARDWARE PERFORMANCE . . . . .    | 14   |
| 4.1 SPECIMEN TEST RESULTS. . . . .              | 14   |
| 4.2 COMPONENT EVALUATION TEST RESULTS . . . . . | 17   |
| 4.3 RELIABILITY DEMONSTRATION TEST . . . . .    | 18   |
| 5.0 CONCLUSIONS AND RECOMMENDATIONS . . . . .   | 18   |
| 5.1 CONCLUSIONS. . . . .                        | 18   |
| 5.2 RECOMMENDATIONS . . . . .                   | 18   |
| FIGURES   |      |
| 1 Design Configuration . . . . .                | 5    |
| 2 Valve Cross-Section . . . . .                 | 6    |
| 3 Mask and Hose Assembly . . . . .              | 7    |
| 4 Subjective Breathing Tests . . . . .          | 19   |
| 5 Subjective Breathing Tests . . . . .          | 20   |

FORWARD

This is the final report for the effort performed by Bendix Corporation, for the United States Navy, Naval Air Systems Command in accordance with the requirements of Contract No. N62269-76-C-0214. The monitoring laboratory was the Naval Air Development Center. Mr. Matthew Lamb and Mr. Richard Routzahn, Aircraft and Crew Systems Technology Directorate, were the project engineers. The effort was performed at the Instrument and Life Support Division in Davenport, Iowa between June 1976 and February 1977.

## 1.0 INTRODUCTION

This report describes the design, fabrication, and performance testing of two Anti-Suffocation Valves, Bendix Part No. 3267010-0101 to fulfill the requirements of Item 0001 of Navy Contract N62269-76-C-0214. NW

The Anti-Suffocation Valve developed during this program provides the aircrewmember with an extended protection envelope that removes the suffocation danger present in existing systems where the emergency oxygen supply becomes depleted and an aircrewmember cannot remove his mask.

In addition to providing protection against suffocation, the valve overcomes the danger of an aircrewmember unknowingly breathing air during normal in-flight conditions and prevents the entrance of water in the event of an aircraft ditching.

## 2.0 TECHNICAL DISCUSSION

### 2.1 PURPOSE

This program was undertaken to design, fabricate, and conduct performance tests of two prototype anti-suffocation valves in accordance with the Statement of Work contained in section F of NADC Contract N62269-76-C-0214.

### 2.2 ADMINISTRATIVE DATA

|                            |  |
|----------------------------|--|
| Manufacturer               | Instruments & Life Support Division<br>The Bendix Corporation<br>Davenport, Iowa 52808 |
| Mfr. Part No. 3267010-0101 | Serial Numbers 703001E and 703002E   |
| Security Classification:   | Unclassified   |
| Disposition of Specimen:   | Shipped to NADC 14 March 1977  |

### 2.3 SUMMARY

After evaluation testing of several different types and sizes of hydrophobic filter elements, an anti-suffocation valve was designed to meet the requirements outlined in NADC Contract N62269-76-C-0214 Statement of Work. Two complete prototype valve assemblies and certain individual parts were fabricated, assembled and evaluation tested during the design/development phase. Modifications resulting from this effort were included in the final two prototypes which have been submitted to NADC for further performance and environmental testing. The test results obtained during testing by Bendix are summarized in section 4.0 and indicate the units meet the performance requirements of the Work Statement which are embodied in this report in the form of an Anti-Suffocation Valve Specification (section 3.0). Reliability information, maintainability programs, personnel training, ground support equipment, and other factors needed for fleet introduction of the anti-suffocation valve are included in the Preliminary Integrated Logistics Support Plan and the Reliability and Maintainability Program Plan, both previously submitted.

## 2.4 DESCRIPTION OF SPECIMEN

The design configuration of the anti-suffocation valve is shown in figure 1 and a cross-section drawing depicting the internal parts of the valve is shown in figure 2. The complete valve assembly is small enough to permit retrofit by simply installing it between an existing A-13A mask and breathing hose as shown in figure 3. Because of its lightweight (<2 oz.) and a diameter slightly larger than the breathing hose, no added windblast or g-force problems are anticipated. Fittings on each end of the valve body are designed for attachment to the mask and hose without requiring additional or replacement clamps. By positioning the air entry port inward (toward the crewmember), the primary valve inlet is shielded from direct windblast force.

Four major components make up the complete valve:

1. A primary anti-suffocation valve normally held closed by spring force and the absence of high suction force when oxygen is available.
2. A secondary airtight closure clip which is manually placed in a closed position by the aircrewmember and is secured in that position by the clip's spring force.
3. A pull-away lanyard assembly that is secured to the closure clip on one end and may be attached to the aircraft on the other end.
4. A hydrophobic type membrane which serves as a means of preventing water entry ahead of the primary valve.

The primary valve close is a metal valve-to-metal seat design similar to an anti-suffocation valve developed and produced by Bendix for the 29276 Oxygen Breathing Regulator. Over 1200 of these valves have been placed in service since 1968 on the F111 and other aircraft.

The secondary closure is a C-shaped flexible metal spring clip with a bonded silicone rubber gasket on the inner side. This gasket completely seals off the anti-suffocation valve inlet passage.

A pre-coiled nylon lanyard is secured to the closure clip on one end and the other end is free for connection to the aircraft.

The hydrophobic membrane used to repel water is composed of borosilicate glass microfibers bonded into a cylinder which completely seals off the primary valve inlet passage from water entry.

## 2.5 OPERATION

The operation of the valve is as follows (refer to figure 2): Under normal breathing with the mask in place, oxygen from the aircraft supply is delivered through the valve housing into the mask at a slight positive pressure. This pressure coupled with the anti-suffocation valve spring ① exerts a sealing force on the valve ②, keeping it in a closed position. Valve opening occurs

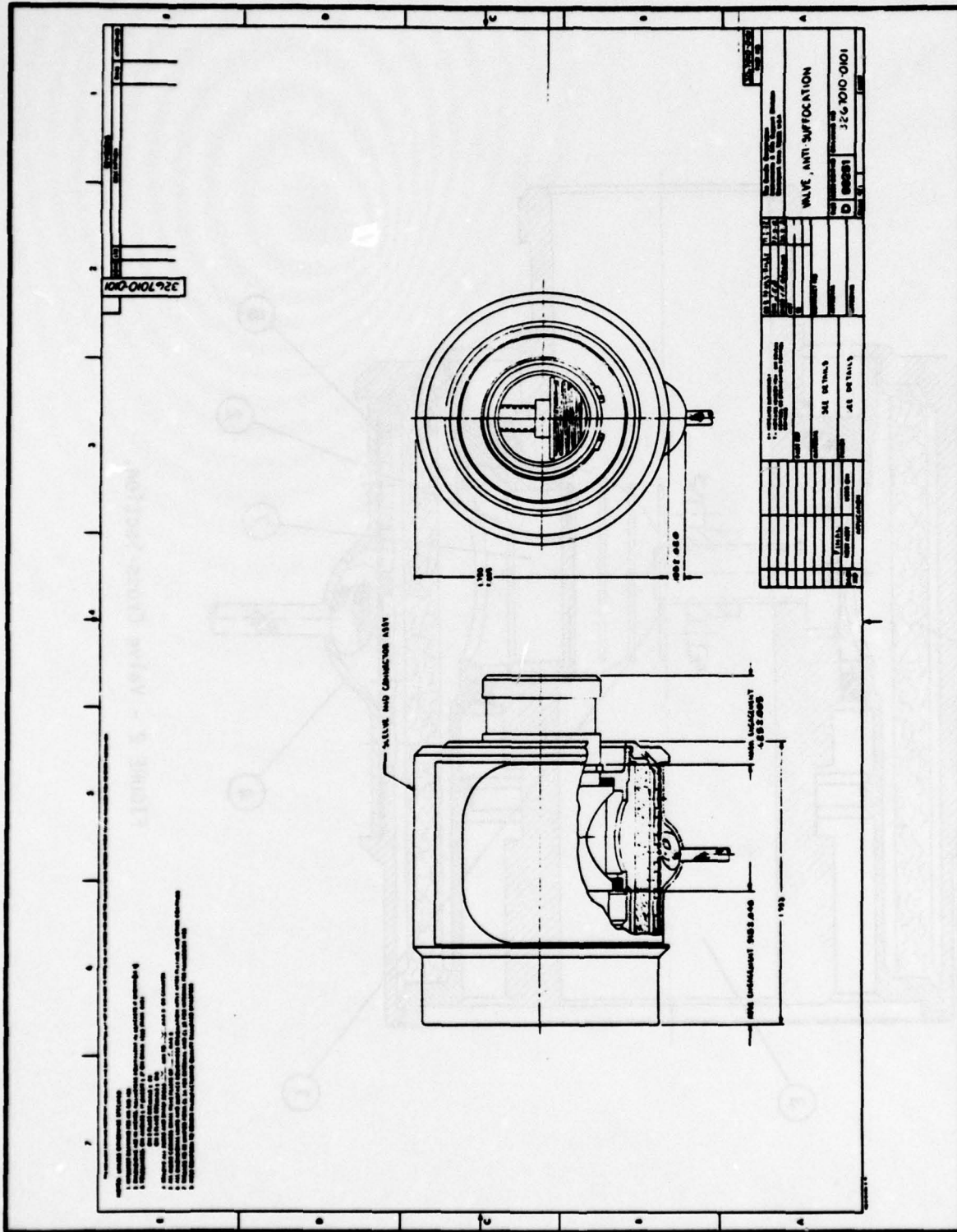

FIGURE 1 - Design Configuration.

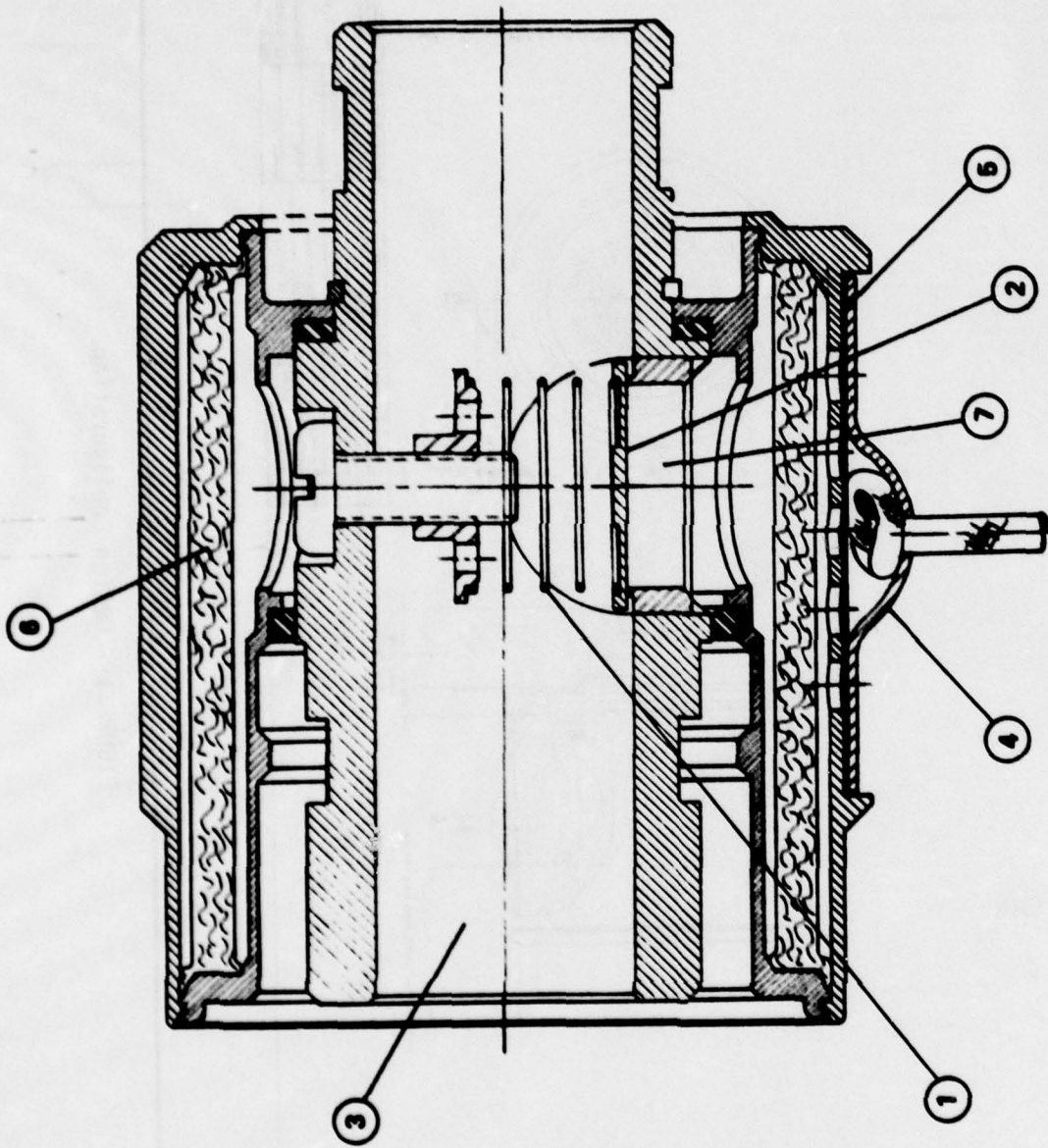

FIGURE 2 - Valve Cross-Section.

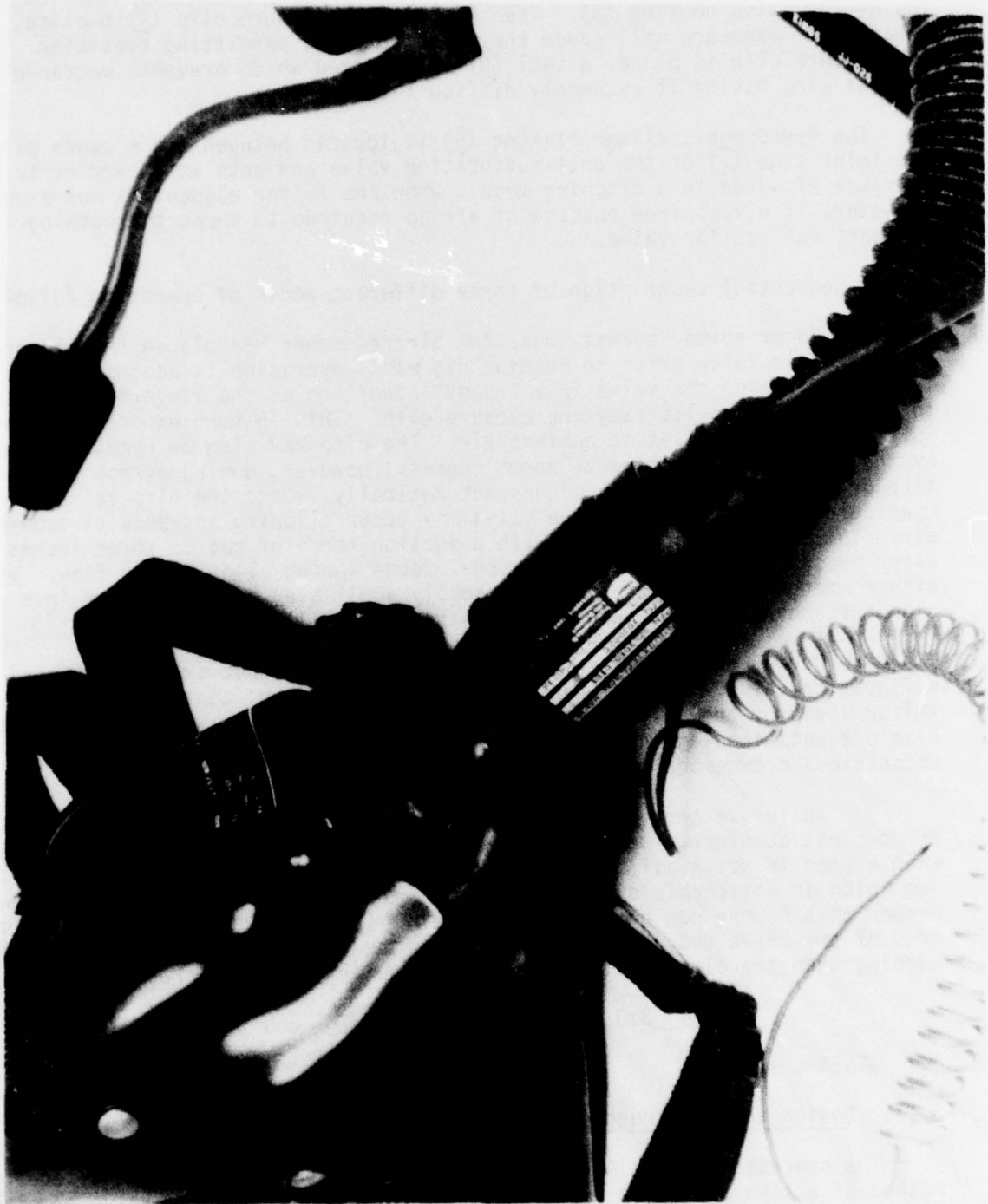

FIGURE 3 - Mask and Hose Assembly.

only when oxygen is not present and the aircrewmember develops a suction force inside the valve housing ③. Then without the closure clip ④ in place, ambient air pressure will cause the valve to open, permitting breathing. With the closure clip in place, a seal ⑤ is effected which prevents entrance of ambient air, making it extremely difficult to breathe.

The hydrophobic filter element ⑥ is located between the closure clip and inlet side ⑦ of the anti-suffocation valve and acts as a barrier to the entrance of water in a ditching mode. When the filter element is not exposed to water, it allows free passage of air as required to support breathing through the anti-suffocation valve.

A sequential description of three different modes of operation follows:

1. Under normal egress, once the aircrewmember has placed the closure clip over the valve prior to donning his mask; operation is accomplished by initially placing the valve in a "ready" condition as the lanyard, attached to the aircraft, pulls away the closure clip. This in turn exposes the anti-suffocation valve inlet to ambient air. The clip may also be removed manually by the aircrewmember prior to normal egress; however, during egress by ejection or ditching, pull-away occurs automatically. Once the clip is removed, opening of the anti-suffocation valve may occur allowing entrance of ambient air. This can be accomplished with a suction force of two to three inches of water pressure which overcomes the seal force spring allowing air flow. With either emergency or aircraft oxygen supply available, a two to three inch suction force cannot be developed; thus the valve will remain closed.

2. During an underwater ditching condition, without oxygen, the anti-suffocation valve will be in an operable mode; however, the hydrophobic filter ahead of the valve prevents water from entering the valve. The filter also prevents inhalation of water during a flotation condition in which an unconscious crewmember may be exposed to splashing.

3. An inadvertent armed position (i.e., the closure clip is not in place or does not completely seal) will allow ambient air entry through the valve when oxygen is not available; thus the valve is designed to produce a fluttering which is noticeable during inhalation, thus serving to warn the aircrewmember that he may not be breathing oxygen. In addition, a bright red colored area of the valve body normally covered by the closure clip serves as a visual warning when the closure clip is not in place or is improperly installed.

### 3.0 SPECIFICATION

#### 3.1 GENERAL

##### 3.1.1 Design and Construction

The operation of the Anti-Suffocation Valve shall incorporate a sequential method of activation. The first sequential step shall arm the valve or place it in a standby condition upon egress from the aircraft. The second step shall cause the anti-suffocation valve to operate and provide the capability to breathe ambient air when initiated by the absence of an oxygen supply.

The valve shall not operate when underwater even when both sequential steps have been initiated.

The valve shall be constructed to withstand conditions incidental to shipping, installation and storage.

### 3.1.2 Weight and Dimension

The dimensions of the parts shall be in accordance with Bendix drawing 3267010 (figure 1). The weight of the complete valve assembly shall not exceed 2 oz.

### 3.1.3 Profile

The anti-suffocation valve shall not intrude into the aircrewmember's vision envelope by increasing the mask profile.

### 3.1.4 Materials

#### 3.1.4.1 Metals

Metals shall be of the corrosion-resistant type or suitably treated to resist corrosion due to atmospheric conditions to which the valve might be subjected during storage or normal service.

#### 3.1.4.2 Dissimilar Metals

Unless suitably protected against electrolytic corrosion, dissimilar metals shall not be used in intimate contact with each other. Dissimilar metals are defined in MS33586.

#### 3.1.4.3 Nonferrous Materials

Nonferrous materials shall be used for all parts, except where ferrous materials are essential.

#### 3.1.4.4 Elastomers

All elastomers shall be silicone materials.

#### 3.1.4.5 Protective Treatment

When materials are used in the construction of the valve that are subject to deterioration when exposed to the environmental conditions likely to occur during storage or normal service usage, they shall be protected against such deterioration in a manner that will in no way prevent compliance with the requirements of this specification. The use of any protective coating that will crack, chip, or scale with age or extremes of environmental conditions shall be avoided.

### 3.1.5 Lubrication

The valve shall not require periodic lubrication.

### 3.1.6 Interchangeability

All parts having the same manufacturer's part number shall be functionally and dimensionally interchangeable.

### 3.1.7 Identification of Product

The valve shall be marked for identification in accordance with MIL-STD-130.

### 3.1.8 Operation

The valve shall be capable of operating as specified when subjected to the following emergency situations:

#### 3.1.8.1 Ejection

In an ejection situation, the anti-suffocation valve shall operate. Egress from the aircraft shall arm the valve and, in the event oxygen is no longer available, the valve shall operate and provide the capability to breathe ambient air.

#### 3.1.8.2 Water Entry (Ditching)

In an aircraft ditching situation, the aircrewmember may egress from the aircraft, with the Rigid Seat Survival Kit (RSSK) bodily attached and the emergency oxygen supply operating, or disengaged from the RSSK. In either event, egress shall arm the valve and provide the capability to breathe ambient air.

a. RSSK Attached. In the event the aircrewmember egresses with the RSSK attached and the emergency oxygen supply operating, the valve shall be armed and upon depletion of the emergency oxygen supply, the valve shall provide the capability to breathe ambient air.

b. RSSK Not Attached. In the event the aircrewmember egresses with the RSSK not attached and no emergency oxygen supply, the valve shall be armed and provide the capability to breathe ambient air.

Under no circumstances shall the valve operate when underwater, even when the valve has been armed and no oxygen supply is present.

#### 3.1.8.3 Manual Egress

In a manual egress situation caused by an emergency such as fire, while the aircraft is on the ground, the aircrewmember may disengage his oxygen supply and exit from the aircraft with his mask in place. In this situation, the anti-suffocation valve shall be operable. During a short period where the aircrewmember may have to pass through flames, he can be expected to hold his breath until reaching a safe area where he shall be able to breathe through an operable anti-suffocation valve.

### 3.1.9 Oxygen System Compatibility

The anti-suffocation valve shall be an integral part of the A-13 Mask Assembly.

Oxygen, Pressure Breathing (MIL-M-6482C), Hose Assembly, Breathing Oxygen (MIL-H-81581/4), and Regulator, Chest Mounted, 100% Positive Pressure (MIL-R-81553). The anti-suffocation valve shall also be compatible with Regulator, Chest Mounted, Positive Pressure, Diluter Demand (Bendix P/N 99251-3260002-0201, and/or Robertshaw P/N 900-002). The anti-suffocation valve shall not in any way compromise, limit or interfere with the operation and performance requirements of the mask, hose and regulator system.

### 3.1.10 System Readiness

The design shall incorporate a means for visual inspection to verify the system readiness of the anti-suffocation valve.

## 3.2 PERFORMANCE

### 3.2.1 Capacity

The anti-suffocation valve shall provide a breathing capacity of 50 liters/min.

### 3.2.2 Pressure Drop

The pressure drop shall be minimized and shall not exceed  $7\frac{1}{2}$  inches of water at any point in the inspiration cycle within the specified breathing capacity.

### 3.2.3 Valve Leakage

3.2.3.1 With a suction of one inch of water applied to the inlet side of the valve for a period of two minutes, leakage shall not exceed 25 cc./min.

3.2.3.2 With a suction of 13 inches of water applied to the inlet side of the valve for a period of two minutes, leakage shall not exceed 30 cc./min.

### 3.2.4 Overall Leakage

3.2.4.1 The valve fittings shall be designed so that when properly attached to the mating hose and mask, the total outward leakage through the attachments and across the anti-suffocation valve seat shall not exceed 50 cc./min when a pressure of 13 inches of water is applied internally.

3.2.4.2 With a suction of 20 inches of water or more applied internally, the inward leakage through the valve shall not exceed 3 LPM.

### 3.2.5 Closure Clip

The anti-suffocation valve closure clip when installed in place shall serve to prevent inadvertent breathing of ambient air by providing a seal in accordance with 3.2.4.2. The separation force required to remove the clip (placing the valve in a ready position) shall not exceed 10 lbs. when pulled away in any direction encompassed with a  $90^{\circ}$  cone with its apex at the clip to lanyard attachment point. The possibility of the clip being installed improperly or not installed at all, shall be evident by a visual indication.

**3.2.6 Underwater Operation**

The valve shall provide the capability to prevent the entrance of water when completely submerged to depth of 30 feet.

**3.2.7 Operation Sequence**

The anti-suffocation valve shall have a two-step operational sequence.

3.2.7.1 The first step shall place the valve in a "ready" condition providing air breathing capability in accordance with 3.2.1 when oxygen is no longer being supplied.

3.2.7.2 The second step shall provide the capability to breathe ambient air in the absence of an oxygen supply in accordance with 3.2.2.

**3.2.8 Operation Conditions**

Anti-suffocation valve operation during various conditions shall be as follows:

**3.2.8.1 Normal In-Flight Condition**

The valve shall not operate while meeting the leakage requirements of 3.2.3 and 3.2.4.

**3.2.8.2 Ejection Condition**

The valve shall be in a "ready" condition providing air breathing capability per 3.2.1 and 3.2.2 when oxygen is no longer being supplied.

**3.2.8.3 Ditching Condition**

The valve shall be in a "ready condition providing air breathing capability per 3.2.1 and 3.2.2 when oxygen is no longer being supplied; however, if underwater the valve shall prevent entrance of water per 3.2.6.

**3.2.8.4 Manual Egress (aircraft ground fire)**

The valve shall be in a "ready" condition providing air breathing capability per 3.2.1 and 3.2.2 when oxygen is no longer being supplied. The valve shall be placed in this condition automatically upon egress or the aircrewmember may manually remove the closure clip by exerting a pull force per 3.2.5.

**3.2.9 Inadvertent Operation**

When the closure clip is inadvertently removed or does not seal properly, the anti-suffocation valve shall produce a distinct audible noise upon opening, serving to warn the aircrewmember that he may not be breathing oxygen.

**3.3 ENVIRONMENTAL CONDITIONS**

The anti-suffocation valve shall be capable of performing as specified when subjected to the following environmental conditions:

### 3.3.1 Low Temperature Operation

After exposure to a temperature of  $-65^{\circ} + 5^{\circ}\text{F}$  for three hours and while at this temperature the valve shall be capable of performing per 3.2.1 thru 3.2.5. Upon returning to room temperature, the valve shall be capable of performing to the same requirements.

### 3.3.2 High Temperature Operation

After exposure to a temperature of  $+160^{\circ} + 5^{\circ}\text{F}$  for three hours and while at this temperature the valve shall be capable of performing per 3.2.1 thru 3.2.5. Upon returning to room temperature, the valve shall be capable of performing to the same requirements.

### 3.3.3 Ozone Resistance

All materials used in construction of the valve shall be capable of passing the ozone resistance test in which sample slabs of material are submitted for testing. The test apparatus shall be in accordance with ASTM Method No. D1149. The test slabs shall be elongated 20 percent, place in an ozone-free atmosphere for 24 hours, then placed in the ozone chamber. The chamber shall be adjusted to  $100 \pm 2^{\circ}\text{F}$  and to give an exposure of ozone concentration of  $120 \pm 10$  parts by volume of ozone per million parts by volume of air. The air-ozone velocity in the chamber shall be at least two feet per second. The material shall be exposed to these conditions for 60 minutes. The test slabs shall then be examined under LOX magnification and shall not show any evidence of checking, cracking or damage.

### 3.3.4 Windblast

The anti-suffocation valve shall be capable of operating per 3.2.1, 3.2.2, 3.2.3, 3.2.4.1, and 3.2.6 after being exposed to a windblast as specified in MIL-V-22272B.

### 3.3.5 Standard Military Conditions

The anti-suffocation valve shall be capable of meeting the following requirements of MIL-STD-810, Environmental Test Methods 503, 504, 507, 508, and 509.

### 3.3.6 Acceleration

The operation of the valve shall not be affected by:

a. Air combat maneuver "G" loadings.

1. Peak G<sub>z</sub>. Peak G<sub>z</sub> levels of nine G<sub>z</sub> with an onset rate of  $3\frac{1}{2}$  G<sub>z</sub> per second, time at peak of one second, and a decay rate of  $3\frac{1}{2}$  G<sub>z</sub> per second.

2. Sustained G<sub>z</sub>. A sustained G<sub>z</sub> level of seven G<sub>z</sub> for 30 seconds with an onset rate of  $3\frac{1}{2}$  G<sub>z</sub> per second and a decay rate of  $3\frac{1}{2}$  G<sub>z</sub>.

b. Carrier operations "G" loadings.

1. Launch 2.5-6 G<sub>x</sub> (positive)
2. Recovery 3-5 G<sub>x</sub> (negative)

3.4 RELIABILITY

Reliability shall be an integral part of the valve's design. The valve shall be designed for 2275 MCBF (Mean Cycles Between Failures).

4.0 PROTOTYPE HARDWARE PERFORMANCE

4.1 SPECIMEN TEST RESULTS

Functional tests were conducted by Bendix on both prototype anti-suffocation valves to verify each valve's capability to meet the functional performance requirements of the contract work statement as embodied in this report, section 3.0 Specifications.

4.1.1 All tests were conducted at local ambient temperature and barometric pressure.

4.1.2 The specific requirements that were verified by tests with the results reported herein include the following:

- 3.1.2 Weight and Dimension
- 3.2.1 Capacity
- 3.2.2 Pressure Drop
- 3.2.3 Valve Leakage
- 3.2.6 Underwater Operation
- 3.2.4 Overall Leakage
- 3.2.5 Closure Clip

4.1.3 Weight and Dimension (3.1.2)

The anti-suffocation valves were examined for conformance with the applicable drawing 3267010-0101 (figure 1). One unit was weighed and the weight recorded.

| <u>Spec. Limit</u> | <u>S/N 703001E</u> | <u>S/N 703002E</u> |
|--------------------|--------------------|--------------------|
| 2 oz. max.         | 1.98 oz.           | Not weighed        |

4.1.4 Capacity (3.2.1) and Pressure Drop (3.2.2)

Both anti-suffocation valves were tested at various flow rates up to 50 LPM and the pressure drop at corresponding flow rates was measured and recorded.

| <u>Flow Rate (LPM)</u> | <u>Pressure Drop Inches H<sub>2</sub>O</u> |                    |
|------------------------|--|--------------------|
|                        | <u>S/N 703001E</u>                         | <u>S/N 703002E</u> |
| 10                     | 2.8  | 2.6                |
| 15                     | 3.2  | 2.9                |
| 25                     | 4.1  | 3.55               |
| 50                     | 6.2  | 5.30               |

4.1.5 Valve Leakage (3.2.3)

The capability of the anti-suffocation poppet and valve seat to effect a leak-tight seal preventing the escape of oxygen was measured by applying positive pressures of 1 and 13 inches of water inside the valve and measuring leakage across the valve seat.

| <u>Spec. Δp Inches H<sub>2</sub>O</u> | <u>Spec. Allowable Leakage cc/min.</u> | <u>S/N 703001E</u> | <u>S/N 703002E</u> |
|---------------------------------------|--|--------------------|--------------------|
| 1                                     | 25                                     | 0                  | 0                  |
| 13                                    | 30                                     | 0                  | 0                  |

4.1.6 Overall Leakage-Outward (3.2.4.1)

The capability of the entire valve assembly, including the end fitting interfaces with the mask and breathing hose and poppet and valve seat to effect a leaktight seal preventing the escape of oxygen was measured by applying an internal positive pressure of 13 inches of water and measuring the total outward leakage.

| <u>Internal Pressure Inches H<sub>2</sub>O</u> | <u>Spec. Allowable Leakage cc/min.</u> | <u>S/N 703001E</u> | <u>S/N 703002E</u> |
|--|--|--------------------|--------------------|
| 13   | 50                                     | 0                  | 0                  |

4.1.7 Overall Leakage-Inward (3.2.4.2)

The capability of the closure clip to prevent inadvertent breathing of ambient air when installed on the valve was established by applying a suction force of >30 inches of water and measuring and recording the inward leakage.

| <u>Spec. Limit</u>       | <u>S/N 703001E</u> | <u>S/N 703002E</u> |
|--------------------------|--------------------|--------------------|
| Suction $\geq$ 20 inches | >30                | >30                |
| Leakage $\leq$ 3 LPM     | 1-2                | 1-2                |

4.1.8 Closure Clip (3.2.5)

In addition to verifying the sealing capability of the closure clip, the

separation force required to remove the clip (placing the valve in a ready position) was measured when pulled away in three different directions within a 90° cone.

| <u>Direction of Pull</u> | <u>Spec. Limit-lbs.</u> | <u>Results-lbs.</u> |
|--------------------------|-------------------------|---------------------|
| Along Cone Axis          | 10                      | 3.86                |
| Downward 45° from Axis   | 10                      | 8.75                |
| Sideward 45° from Axis   | 10                      | 2.75                |

4.1.9 Underwater Operation (3.2.6)

The valve capability to prevent the entrance of water when completely submerged was verified by conducting two different submersion tests, each followed by further testing to measure effect on capacity and pressure drop characteristics of the valves.

4.1.9.1 Submersion Test

Each valve assembly with the closure clip removed was submerged underwater for a minimum period of 10 minutes. Immediately afterward the valves were operated at flows up to 50 LPM with both flow rate and pressure drop data measured and recorded.

| <u>Flow Rate (LPM)</u> | <u>Pressure Drop (In. H<sub>2</sub>O)</u> |                    |
|------------------------|---|--------------------|
|                        | <u>S/N 703001E</u>                        | <u>S/N 703002E</u> |
| 10                     | 2.8                                       | 2.6                |
| 15                     | 3.2                                       | 2.9                |
| 25                     | 4.0                                       | 3.6                |
| 50                     | 6.2                                       | 5.7                |

The valves were also visually examined to verify that water had not come into the area downstream of the hydrophobic filter element. No evidence of water was detected in either valve.

4.1.9.2 Inhalation Submersion Test

Each valve assembly with the closure clip removed was submerged underwater and subjected to six inhalation cycles each at 22 inches of water suction. The valves were removed from the water and then operated at flows up to 50 LPM with both flow rate and pressure drop data measured and recorded.

| <u>Flow Rate (LMP)</u> | <u>Pressure Drop (In. H<sub>2</sub>O)</u> |                    |
|------------------------|---|--------------------|
|                        | <u>S/N 703001E</u>                        | <u>S/N 703002E</u> |
| 10                     | 5.9                                       | 5.8                |
| 15                     | 7.4                                       | 7.5                |
| 25                     | 10.0                                      | 11.0               |
| 50                     | 15.7                                      | 19.0               |

The valves were visually examined again to verify that water had not come into the area downstream of the hydrophobic filter element. No evidence of water was detected in either valve. It should be noted that with continued or subsequent operation of the anti-suffocation valves the pressure drop decreased to its original levels. The high initial levels appear to be caused by surface water coverage on the outside of the filter element and water blockage in the cavity between the filter O.D. and the housing I.D. Both conditions are reduced as airflow tends to evaporate the water and additional water drainage occurs in the cavity. This condition is discussed further in section 5.0.

4.2 COMPONENT EVALUATION TEST RESULTS

Several component tests were conducted during the development program to determine individual component characteristics in the areas of flow capacity, pressure drop, and hydrophobic quality. Results of these tests are included because the work was performed during the contract and it is felt that the data is informative.

4.2.1 Component Pressure Drop Tests

Tests were conducted to determine the pressure drop caused by the valve poppet, and spring and guide protrusion into the main breathing gas stream. Pressure drop through the inner housing alone and all housings together, less the valve, was measured in addition to pressure drop through the valve alone, the entire valve assembly with the valve positioned in line with the air inlet holes and 180° away from the air inlet holes was also tested.

|   | <u>Suction Inches H<sub>2</sub>O</u> |               |
|---|--------------------------------------|---------------|
|   | <u>25 LPM</u>                        | <u>50 LPM</u> |
| Line Pressure Resulting from Valve Components in Gas Stream |                                      |               |
| Valve Housing without Components                            | .10                                  | .30           |
| Valve Housing with Components in Place                      | .15                                  | .35           |
| Pressure Drop through Housing Parts and Filter              |                                      |               |
| Inner Housing   | .05                                  | .25           |
| Inner and Outer Housing                                     | .15                                  | .55           |
| Both Housings and Filter without Valve                      | 1.90                                 | 4.35          |
| Pressure Drop through Valve Alone                           | 2.50                                 | --            |
| Pressure Drop through Complete Assembly                     |                                      |               |
| Valve in Line with Small Air Inlet Holes                    | 4.30                                 | --            |
| Valve Rotated 180° from Small Air Inlet Holes               | 4.30                                 | --            |

In addition to pressure drop tests on valve and housing parts, a number of subjective breathing tests were conducted on subjects prior to selection of the filter size and water repellancy treatment. An example of data from these tests is shown in figures 4 and 5.

#### 4.2.2 Inadvertent Operation

Considerable development testing was done to achieve valve operating having a distinct audible noise to meet the requirement of 3.2.9. Quantitative values being absent as a requirement, data was not recorded and results were based on subjective assessment alone. Noisy operation was attained through all flow ranges with the final configured valve tested on the test stand; however, the same noise level and presence was difficult to duplicate consistently when testing by actually breathing through the valve attached to the mask.

#### 4.3 RELIABILITY DEMONSTRATION TEST

Bendix elected to verify the valve design reliability requirement of 3.4 by conducting cycling tests on both valves. Each valve was cycled at a rate of 15 cycles per minute and an average flow rate of 13 LPM. In accordance with MIL-STD-781, Test Plan IV, each valve was operated a minimum of 2,350 cycles and then tested for compliance with 3.2.3, Valve Leakage. No measurable evidence of leakage was present in either valve.

### 5.0 CONCLUSIONS AND RECOMMENDATIONS

#### 5.1 CONCLUSIONS

It is concluded that the design of the Bendix Anti-Suffocation Valve, type No. 3267010-0101 fulfills the requirements set forth in section F (Statement of Work) of Contract N62269-76-C-0214 and that the two prototype valves submitted to NADC successfully passed the functional tests defined in 4.1.2 of this report and are ready for evaluation by NADC.

#### 5.2 RECOMMENDATIONS

5.2.1 It is recommended that, following successful evaluation by NADC and incorporation of any design improvement modifications generated during the evaluation program, a quantity of anti-suffocation valves for fleet evaluation be fabricated. Building fleet evaluation hardware from molded plastic parts and molded seals should be considered and the advantages weighed against tooling costs. Concurrently, formulation of a formal specification should be completed.

5.2.2 Early in the development testing phase the hydrophobic filter element was tested successfully as a separate part to demonstrate its ability to prevent water passage at a submersion depth equivalent to 30 ft. Significant to the success of this test is the knowledge that the internal pressure inside the breathing hose and filter element is a function of the ambient pressure conditions. However, in the actual valve a cavity exists between the filter element and valve, and when the valve has zero leak as is the case with both prototypes, this cavity would be uncompensated by ambient pressure conditions and the filter would be exposed to a pressure differential equivalent to the force of 30 ft. of

**SUBJECTIVE BREATHING TEST TO DETERMINE PRESSURE DROP OF  
HYDROPHOBIC FILTER MATERIAL IN SERIES WITH STD. BENDIX  
ANTI-SUFFOCATION VALVE**

STANDARD VALVE SPRING YIELDING 8 LPM CRACK OF 4.7" H<sub>2</sub>O

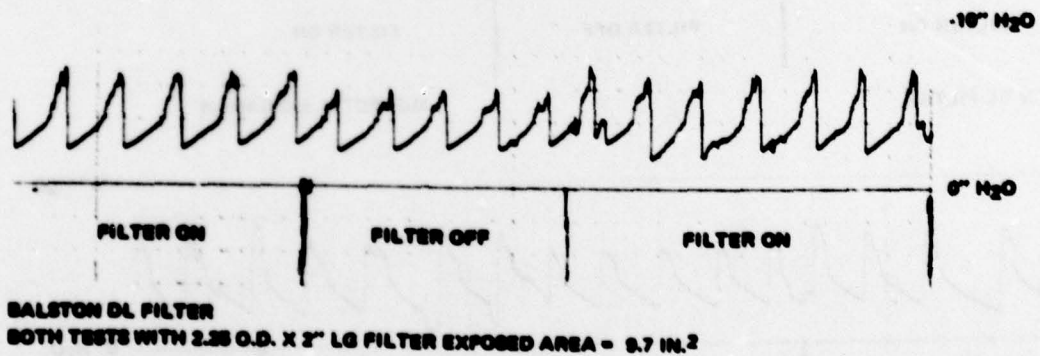
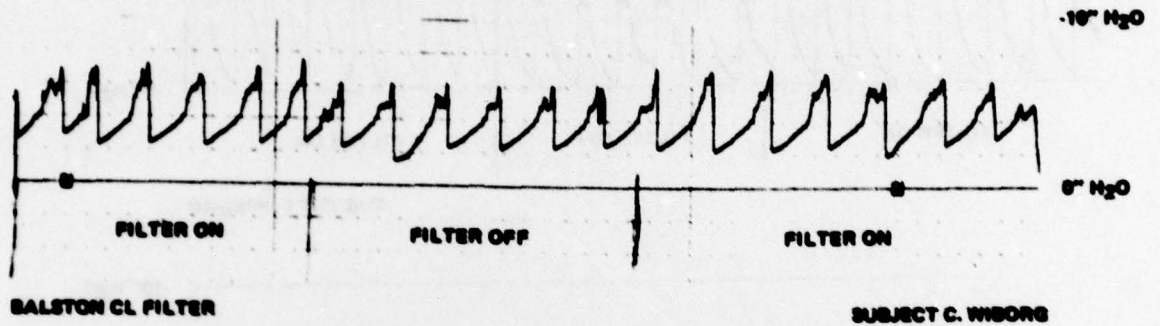

BOTH TESTS WITH 2.25 O.D. X 2" LG FILTER EXPOSED AREA = 9.7 IN.<sup>2</sup>

FIGURE 4 - Subjective Breathing Tests.

**SUBJECTIVE BREATHING TEST TO DETERMINE PRESSURE DROP OF  
HYDROPHOBIC FILTER MATERIAL IN SERIES WITH STD. BENDIX  
ANTI-SUFFOCATION VALVE**

STANDARD VALVE SPRING YIELDING 8 LPM CRACK OF 4.7" H<sub>2</sub>O

2.25" O.D. X 2" LG. FILTER - BALSTON CL TYPE 8.7 IN. SQ. EXPOSED SUBMERGED  
IN H<sub>2</sub>O & SUBJECTED TO REPEATED INHALATION AFTER SUBMERSION

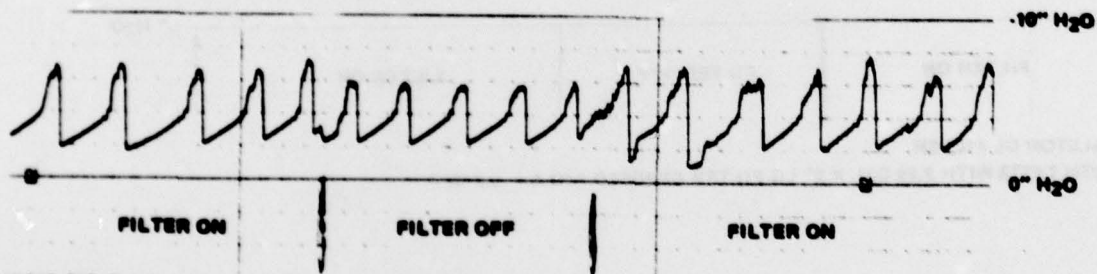
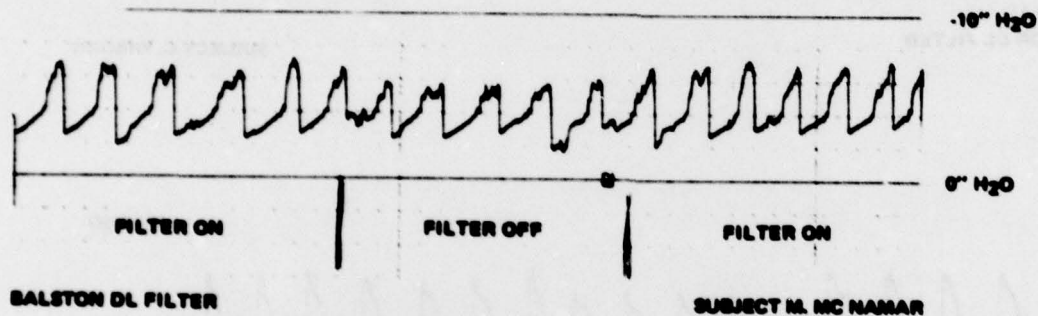
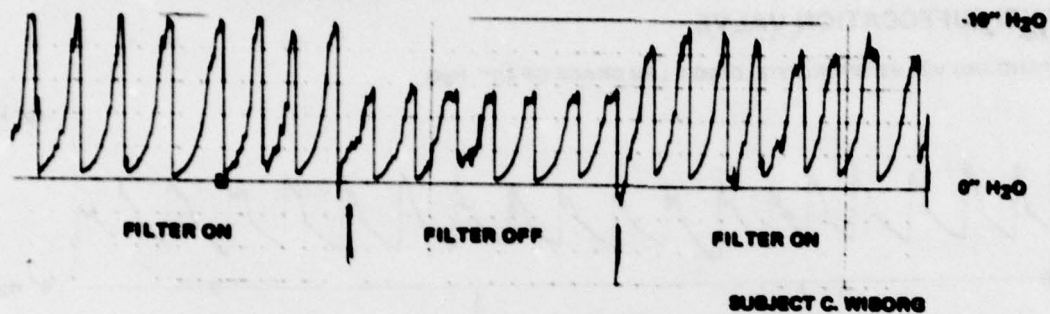

BALSTON CL FILTER  
BOTH TESTS WITH 2.25 O.D. X 2" LG. FILTER EXPOSED AREA - 8.7 IN. SQ.

FIGURE 5 - Subjective Breathing Tests.

water. In this situation water probably would pass through the element. To combat this, it is recommended that consideration be given to building in a fixed leak within the requirements of 3.2.3.

5.2.3 It is recommended that consideration be given to using the closure clip lanyard to deck attachment interface as the separation and hookup point during manual egress and entry. This would minimize the chances of improper clip installation, reduce the clip installation frequency, and increase useful life and assure a closure seal condition which could be readily inspected for leakage as a routine field check.

5.2.4 The ability of the valve to produce an audible noise during operation has proven to be a difficult thing to achieve and the results accomplished with the two prototypes were less than expectation. Testing revealed that how the aircrewmember breathes has a great bearing on whether or not valve flutter is audible and further subjective evaluation by the Navy indicates the need. This should include evaluation with a live microphone.

5.2.5 In the initial stages of selecting a filter element, it became obvious that a surface treatment was necessary to reduce the water surface tension and cause water beading, whereby preventing water coverage from blocking the element after its removal from water. Three different materials were evaluated and two were selected for use on the prototypes. The one material on S/N 703001E is a silicone product of Dow Corning Corporation called "Camp Dry" and the other material on S/N 703002E is called "NALAN W", a product of DuPont. It is recommended that all possible hazard aspects of these materials be investigated thoroughly before final selection is determined.

5.2.6 During water submersion tests of the prototypes, it was noticed that water tended to become trapped between the outer plastic housing where there are no air passage holes and the filter element. This water is minimal, however, if it remains in place it tends to cause high suction forces upon initial breathing attempts.

In fact, this condition is believed to be a contributor to the high suction forces measured during the inhalation breathing test (results are shown in 4.1.9.2). One possible way of reducing this condition would be to design a non-metallic closure clip that encompasses a greater circumference, thus permitting additional passage holes in the outer housing for water drainout.

D I S T R I B U T I O N   L I S T

REPORT NO. NADC-79010-60

AIRTASK NO. WF41-451-401

Work Unit No. DS 903

|  | <u>No. of Copies</u> |
|--|----------------------|
| DDC . . . . .  | 12                   |
| NAVAIRSYSCOM, AIR-950D . . . . .                                   | 8                    |
| (2 for retention)  |                      |
| (2 for AIR-531)  |                      |
| (1 for AIR-5311)   |                      |
| (1 for AIR-5312)   |                      |
| (1 for AIR-5313)   |                      |
| (1 FOR AIR-340)  |                      |
| Naval Medical R&D Command . . . . .                                | 8                    |
| (3 for Code 71)  |                      |
| (3 for Code 7113)  |                      |
| (2 for Code 42)  |                      |
| National Library Of Medicine . . . . .                             | 1                    |
| CNO (OP-098E) . . . . .  | 1                    |
| NAMRL, Pensacola . . . . .   | 2                    |
| NAMRL, Pensacola (Code 09) . . . . .                               | 1                    |
| Naval Training Equipment Center (Tech. Library), Orlando . . . . . | 2                    |
| Naval Submarine Medical Center (Library), Groton. . . . .          | 1                    |
| Naval Health Research Center, San Diego . . . . .                  | 1                    |
| Naval Safety Center, Norfolk . . . . .                             | 1                    |
| Naval Air Test Center, Patuxent River . . . . .                    | 1                    |
| ONR (Code 440), Arlington . . . . .                                | 1                    |
| FAA (AC-100) Oklahoma City . . . . .                               | 1                    |
| FAA (CAMI Library AAC-44D1) . . . . .                              | 1                    |
| 6570 AMRL/DAL Library, Wright-Patterson AFB . . . . .              | 2                    |
| USAFSAM/Aeromedical Library (TSK-4) Brooks AFB . . . . .           | 1                    |
| USAFSAM/RZW/Dr. Farrer, Brooks AFB . . . . .                       | 1                    |
| Air University Library, Maxwell AFB . . . . .                      | 1                    |
| HQ TAC/SGPA, Langley AFB . . . . .                                 | 1                    |
| Division of Aerospace Pathology, Washington . . . . .              | 1                    |
| US Army Armament & Development Command . . . . .                   | 1                    |
| USAFSAM/RA/Dr. Allen, Brooks AFB. . . . .                          | 1                    |
| NASA Lewis Research Center Library, Cleveland . . . . .            | 1                    |
| NASA AMES Research Center, Moffett Field . . . . .                 | 1                    |
| Library of Congress . . . . .                                      | 1                    |
| US Army Aeromedical Research Lab., Fort Rucker . . . . .           | 2                    |
| NAMRL Detachment, New Orleans . . . . .                            | 4                    |
| HQ, USAF/SGPA, Washington . . . . .                                | 1                    |
| COMOPTEVFOR . . . . .  | 1                    |
| HQ, Naval Material Command (034-D) . . . . .                       | 1                    |