

AD-A068 953

GENERAL PRECISION INC GLENDALE CALIF LIBRASCOPE GROUP F/G 19/5
SIMPLIFIED SONAR - FIRE CONTROL FUNCTIONAL INTERFACE DIAGRAMS A--ETC(U)
JUL 64 NOBSR-87598

UNCLASSIFIED

NAVSHIPS-96105

NL

| OF |

AD
A068953



END
DATE
FILMED
7-79
DDC

AD A 068953

DDC FILE COPY,



DDC
RECORDED
MAY 24 1979
RECEIVED
D

CONFIDENTIAL STATEMENT A
Approved for public release.

MOST Project -3

1

LEVEL II

AD A 068953

11 2 July 1964

12 50 p.

DDC FILE COPY.

6

SIMPLIFIED SONAR - FIRE CONTROL
FUNCTIONAL INTERFACE DIAGRAMS
AN/SQS-23 SONAR WITH MK 105,
MK 111, and MK 114 FC.

18

NAVSHIPS

19

96145

ACCESSION NO	
DTIC	White Section <input checked="" type="checkbox"/>
DDC	Def. Section <input type="checkbox"/>
DIAGRAMMED	<input type="checkbox"/>
JUSTIFICATION	
Per Hs. on file	
BY	
DISTRIBUTION/AVAILABILITY CODE	
Dist.	AVAIL. and/or SPECIAL
A	

15 No6SR - 87598

DDC
RECEIVED
MAY 24 1979
D

Librascope Group
General Precision, Inc.
Surface Equipment Division
808 Western Avenue
Glendale 1, California

DISTRIBUTION STATEMENT A
Approved for public release;

402 164

INTRODUCTION

↙ This publication includes simplified functional interface drawings for the AN/SQS-23 Sonar and Fire Control Systems. The drawings are supplemented by brief text which describes the functions of switches and components shown in the diagrams.

Sections are provided for each of three fire control systems:

→ Mk 105,

→ Mk 111,

→ Mk 114.

The drawings and text was prepared as a task under Bureau of Ships Contract NObsr 87598.

Librascope presents this information for use by U. S. Navy personnel concerned with operation, maintenance and checkout of these systems. For more detailed information, the manuals and diagrams for the particular ship or system must be consulted.

↙ Diagrams are grouped by functions to show the interface between fire control and sonar. Diagrams are simplified one line schematics or relay switching schematics. Connector or terminal board identifying characters are shown for that point at which the circuit enters or leaves the sonar or fire control. Due to individual ship variations between fire control switchboards and cabling, these interconnecting components are not specifically identified.

↖

Synchro orders are transmitted in a standard manner so that the receiving synchro will rotate CCW viewed from the shaft end, with an increasing quantity. However, in gearing design it is not always convenient to maintain this direction of rotation, therefore lead interchanges are made at the synchros involved. In the one line diagrams, standard rotation is represented by a simple crow's foot, whereas reversal is represented by a crossed crow's foot.

FIRE CONTROL SYSTEM Mk 105

INTRODUCTION

The Sonar Detecting-Ranging Set AN/SQS-23 is the major target sensor for the Fire Control System Mk 105. The weapons controlled by the system include torpedoes, DASH and hedgehogs.

1. The purpose of the Sonar Set AN/SQS-23 is to locate and track submarine targets and transmit tracking information as synchro data to the Fire Control Mk 105.
2. The Attack Director Mk 5 computes target motion and provides target position keeping information.
3. The ballistic orders are computed by other fire control equipments to provide weapon control.

SYSTEM COMPONENTS

The significant components of the major systems represented on the following diagrams are:

Sonar Detecting-Ranging Set AN/SQS-23

Control-Indicator C-2708/SQ

Signal Data Converter CV750/SQ

Azimuth and Range Indicator IP481/SQ

Target Course Projector SU-2/SQ

Fire Control System Mk 105

Attack Director Mk 5 MOD 5

Relay Transmitter Mk 56 MOD 1

Computer Mk 59 MOD 10 or Computer Mk 108 MOD 1 (Stabilization)

The synchros and servo loops contained in the Attack Director Mk 5 utilizes 115 VAC 60 cycle power and are functionally compatible with the Sonar Set AN/SQS-4.

The Relay Transmitter Mk 56 provides compatibility between the Attack Director Mk 5 and the AN/SQS-23 Sonar Set. The Relay Transmitter Mk 56 provides this compatibility by converting the synchro functions in such a manner that the Attack Director Mk 5 appears to be operating with an AN/SQS-4 Sonar Set, while at the same time the AN/SQS-23 Sonar Set appears to be operating with a Mk 111 or Mk 114 Fire Control System.

The Range module of the Relay Transmitter Mk 56 contains three (3) control transformers to receive Sonar Range (Ra) in the SEARCH mode. Two (2) synchro transmitters are provided to transmit a 60 cycle Sonar Range order (Ra) to the Attack Director Mk 5. Three (3) synchro transmitters are used to transmit a 400 cycle computed Sonar Range order (c(Ra)) to the sonar set for aided tracking. One (1) control transformer is provided to receive the Sonar Range correction (qRa) plus increments of Range (ic(Ra)) computed by the Attack Director. The aforementioned nine (9) synchros are driven by the servo motor A2M61 as shown in Figure 105-2 and 105-5. The Bearing module has seven synchros performing functions similar to the Range module. These are driven by AlMG1 as shown in Figures 105-3 and 105-4. The Memory module provides a smooth transition between modes.

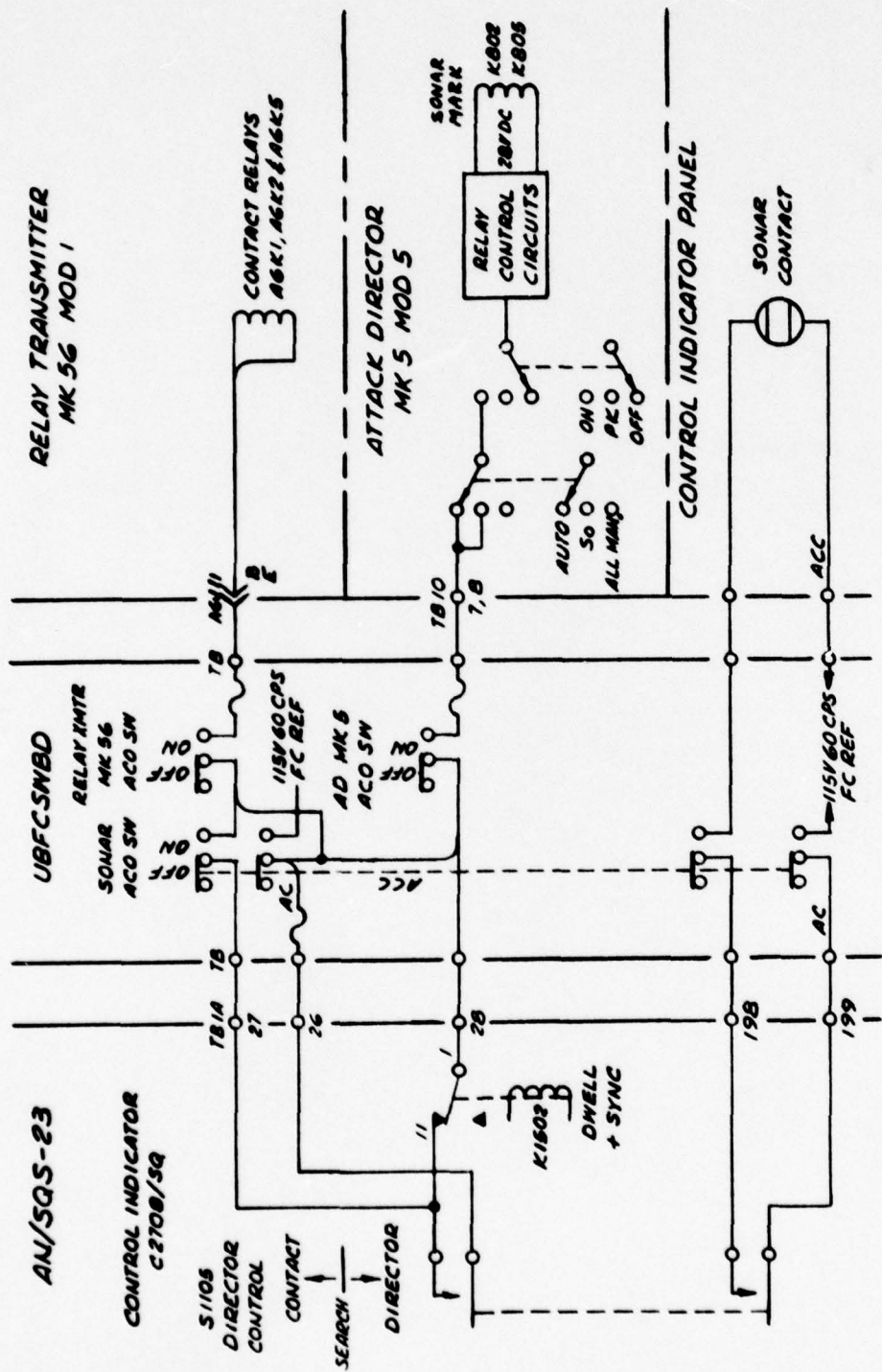

Figure 105-1. Sonar Contact and Control Circuits

SEARCH MODE

During the Search Mode, the "DIRECTOR CONTROL" switch (S1105) on the AN/SQS-23 CONTROL INDICATOR (C-2708/SQ) is placed in the SEARCH position. Part of the contacts on this switch are shown in Figure 105-1. In the SEARCH position, all switch circuits are open.

Other contacts on the "DIRECTOR CONTROL" switch (S1105) are shown in simplified one-line form in the lower left hand corner of Figure 105-5. The purpose of these contacts is to connect synchro reference circuits to the proper sources as the "DIRECTOR CONTROL" switch selects synchro orders from fire control or the range slew circuits in sonar.

In the SEARCH mode relays A6K2 and A6K5 in the Relay Transmitter are deenergized as shown in Figure 105-2. Sonar Range (Ra) is transmitted by synchro transmitters in the sonar to synchro control transformers A2B1, A2B2 and A2B3 in the Range module of the Relay Transmitter Mk 56. The servo motor A2MG1 positions the control transformers to follow the orders received. The Memory module positions the synchro differential transformer A4B9 to maintain a null signal on the rotor of A2B16. (Details of this circuit are not shown). As shown in Figure 105-3, Sonar Bearing (Ba) is transmitted by synchro differential transmitters B2004 and B2003 in the sonar to synchro control transformers A1B1 and A1B3 in the Bearing module of the Relay Transmitter. Servo motor A1MG1, positions the control transformers to follow the orders received.

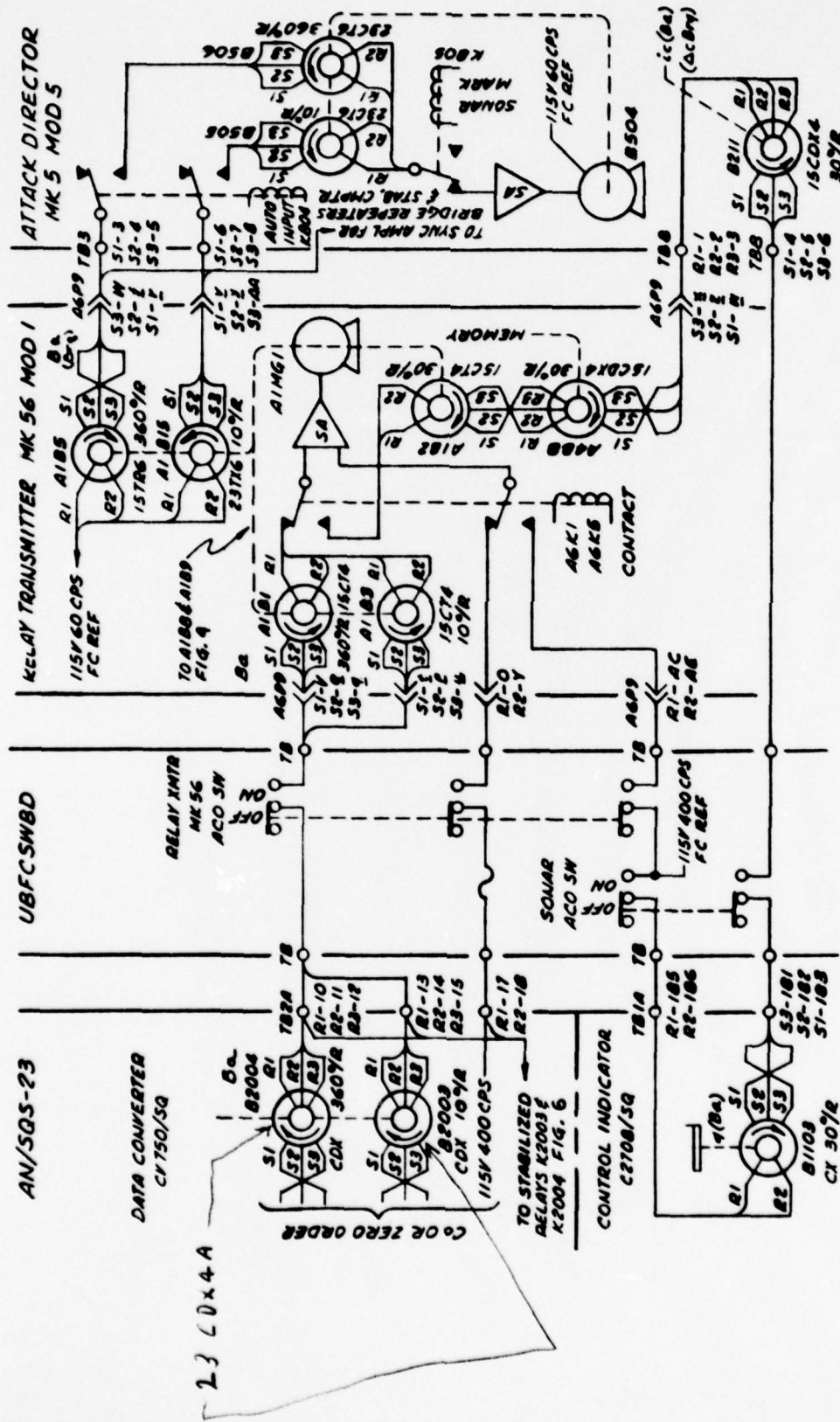

Figure 105-3. Sonar Bearing to Fire Control

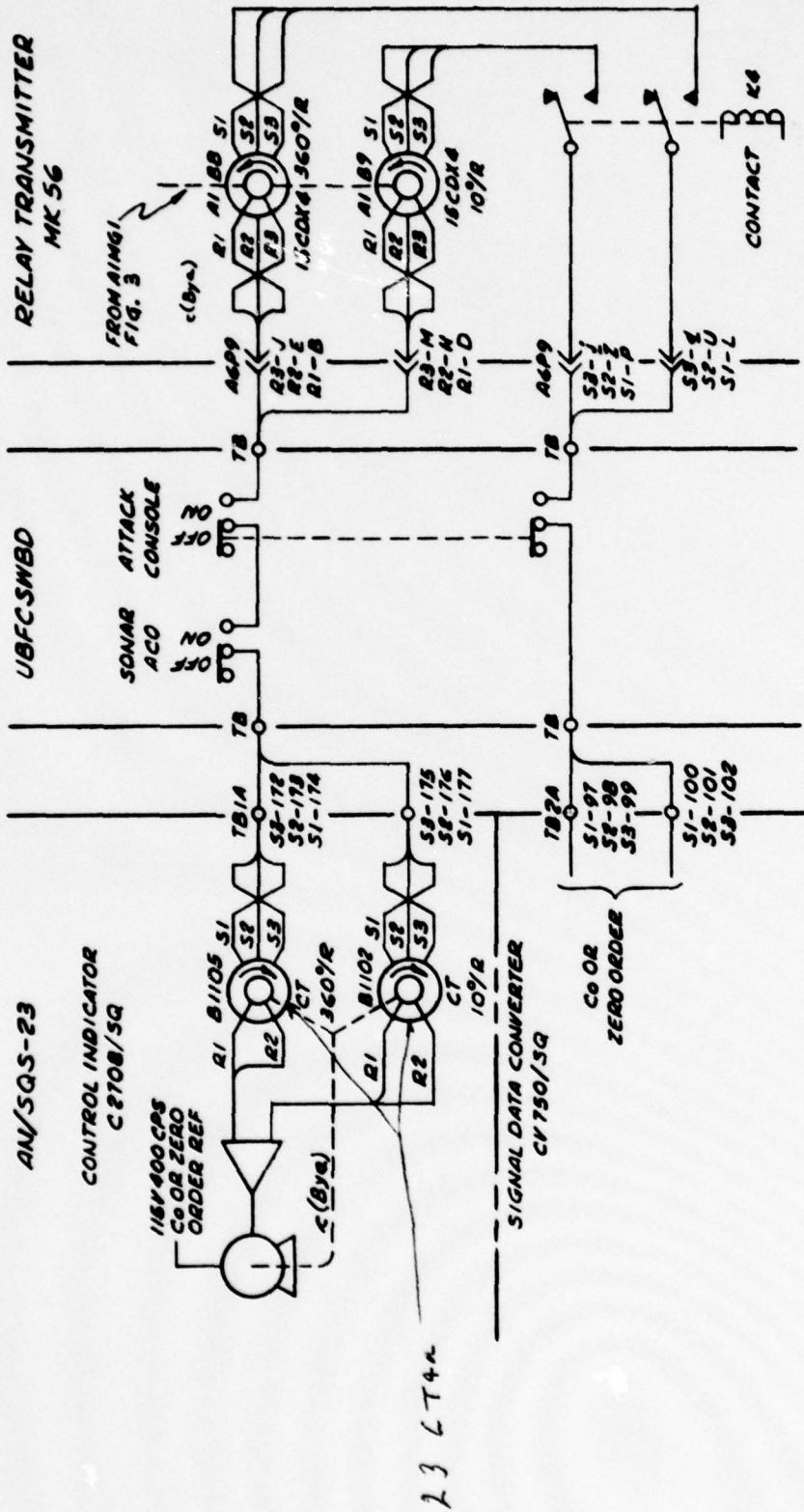

Figure 105-4. c (Bya) from Fire Control to Sonar

The Memory module positions a synchro differential transmitter A4B8 to maintain a null signal on the rotor of A1B2.

ATTACK

As soon as the sonar operator has made a target contact which he is able to track he may place the 'DIRECTOR CONTROL' switch S1105 to CONTACT. As shown in Figure 105-1, the CONTACT relays A6K1, A6K2 and A6K5 in the Relay Transmitter are energized and the Attack Director SONAR MARK relays K802 and K805 are energized except during DWELL plus SYNC periods.

The Range module is positioned to match the value of computed Range ($c(Ra)$). This is accomplished as shown in Figure 105-2. Sonar Range Correction ($q(Ra)$) is transmitted to a synchro differential in the Attack Director B209, which adds the increments of computed Range ($ic(Ra)$). This order feeds through the Memory module synchro differential transmitter A4B9. The Memory module is "Frozen" in the CONTACT mode. The control transformer A2B16, receives the order ($q(Ra) + ic(Ra)$), which continuously updates the Range module. As shown in Figure 105-5, ($c(Ra)$) is transmitted by the Relay Transmitter to the sonar set. The Attack Director receives its Range input from the Relay Transmitter, A2B17 and A2B15. This quantity is considered to be Sonar Range (Ra) since the Range module of the Relay Transmitter is updated by the sonar operator each time he matches the cursor to the target range using ($q(Ra)$). The Bearing module is positioned to match the value of computed Range ($c(Ba)$). As shown in Figure 105-3, the control transformer A1B2 receives its order from sonar, ($q(Ba)$), plus increments of computed bearing ($ic(Ba)$) from the Attack Director. The Memory module is frozen in the

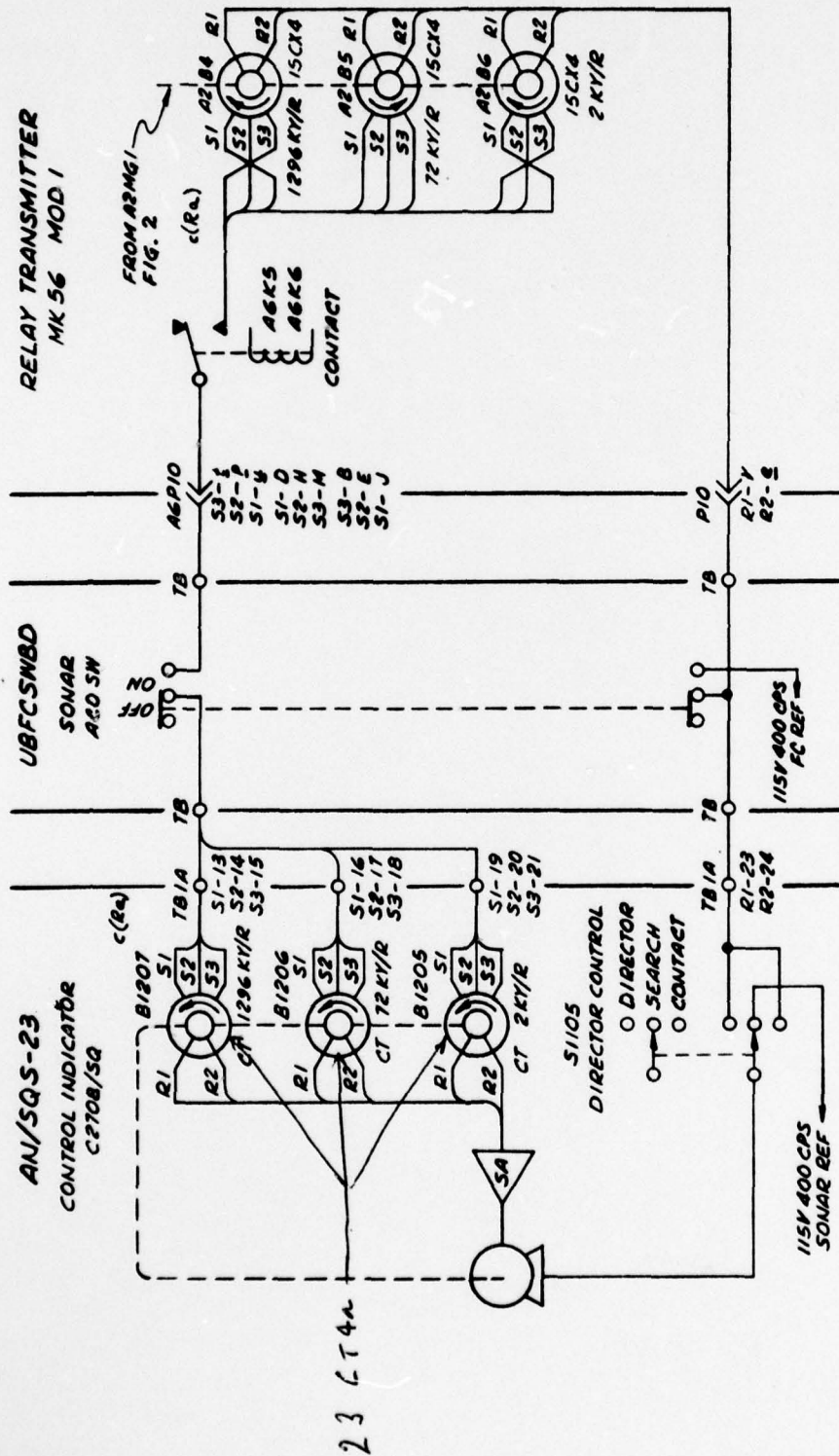

Figure 105-5. c(Ra) from Fire Control to Sonar

CONTACT mode. The sonar set receives computed true bearing ($c(B_{ya})$) from synchro differential transmitters A1B8 and A1B9 in the Relay Transmitter which are positioned by relative bearing. Own Ships Course (C_o), or a zero order, from the sonar set provides the conversion from relative to true bearing. The Attack Director Mk 5 receives relative bearing input from the Relay Transmitter from 60 cycle synchro transmitters A1B5 and A1B15. This quantity is considered to be Sonar Bearing (B_a) since it is updated by the sonar bearing correction ($q(B_a)$) each time the sonar operator matches the cursor to the target bearing.

LOST CONTACT

In the case where contact is lost and the sonar operator wishes to conduct a search, the "DIRECTOR CONTROL" switch S1105 must be placed in SEARCH, prior to moving the handwheels. This action deenergizes the CONTACT relays in the Relay Transmitter as shown in Figure 105-1. The Attack Director automatically assumes a Position Keeping mode based on the last known information. The Relay Transmitter Range and Bearing modules revert to a SEARCH mode following the Sonar Range and Bearing orders.

STABILIZATION

The Computer Mk 59 MOD 10 or Computer Mk 108 MOD 1 generates signals which correct for the effect of ship motion on sonar bearing train. The Stabilization computer receives synchro orders corresponding to ship's motion quantities from the Stable Element and sonar target bearing (B_a) from the Relay Transmitter as shown in Figure 105-6. The Stabilization Computer computes and transmits the corrected bearing order (B_{da}')

to sonar. In case stabilization is not available, relays K2004 and K2006 open and unstabilized bearing orders (Ba) are used in place of (Bda').

TARGET COURSE PROJECTOR

The Azimuth and Range Indicator (1R481/SQ) is fitted with a Target Course Projector SU2/SQ. Target Course order (Ct) is transmitted from the Attack Director as shown in Figure 105-7. The 60 cycle synchro transmitter B306 is energized by a 400 cycle reference to be compatible with the 400 cycle servo in the Target Course Projector.

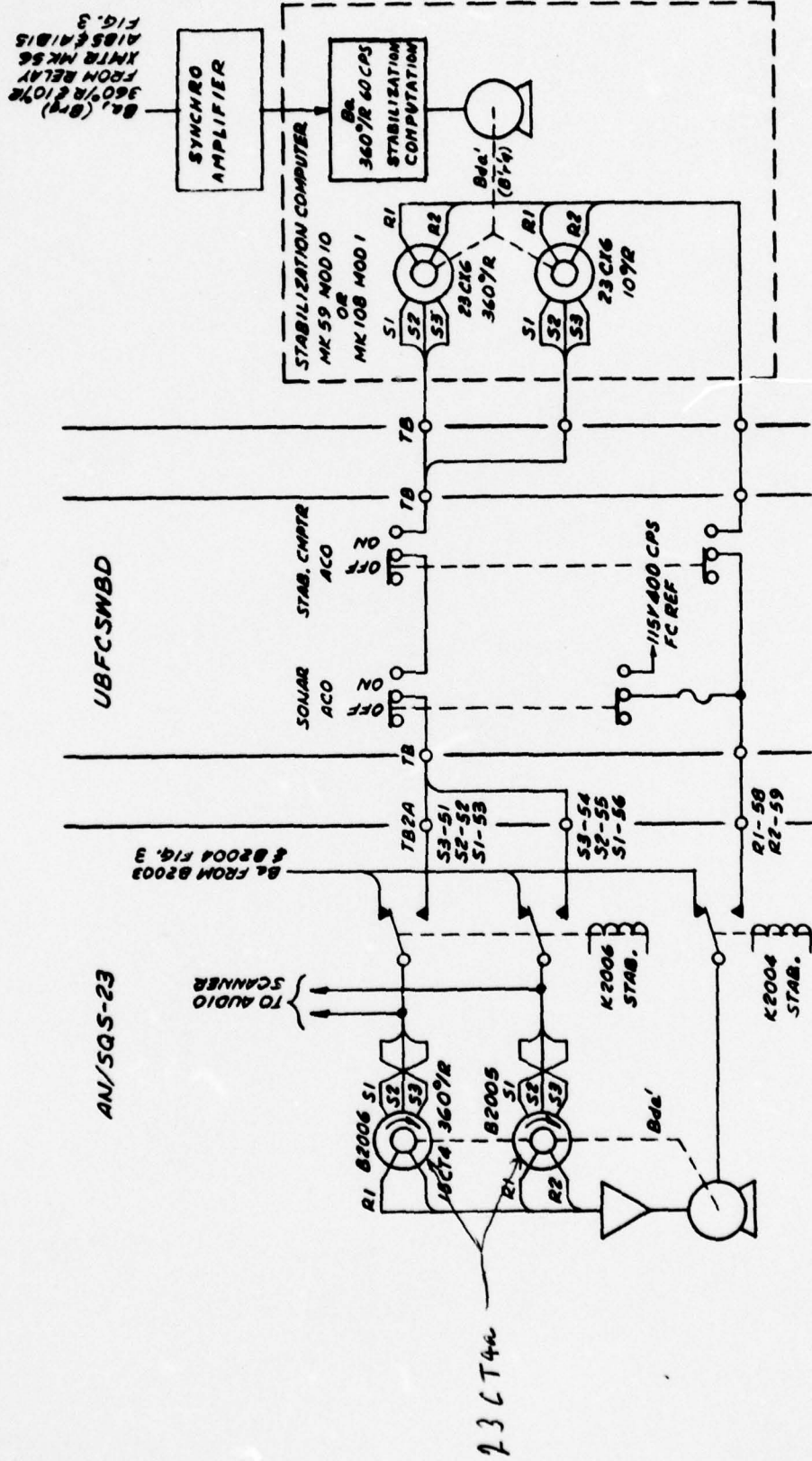

Figure 105-6. Stabilization to Sonar

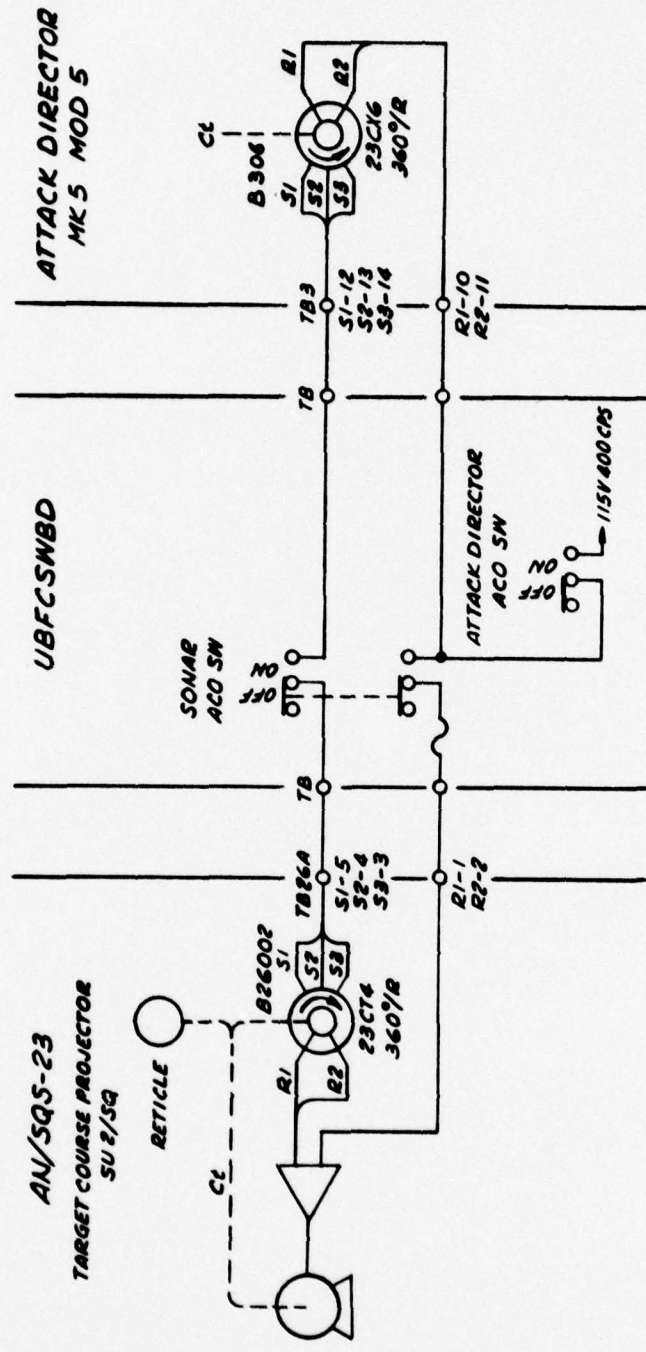

Figure 105-7. Fire Control to Sonar Target Course Projector

FIRE CONTROL GROUP MK 111

INTRODUCTION

The Sonar Detecting-Ranging Set AN/SQS-23 is a major component of the ASROC Weapon System. Three other major components are the Fire Control Group Mk 111, Launching Group Mk 16 and the ASROC Missile.

1. The purpose of the Sonar Set AN/SQS-23 is to locate and track submarine targets and transmit tracking information as synchro data to the Fire Control System Mk 111.
2. The Fire Control System Mk 111 converts synchro data inputs into digital form to compute the solution for the attack problem. Fire control orders are computed and converted into synchro data. This synchro data is transmitted to the launcher and weapon components.
3. The launcher is positioned and the weapon is directed by the fire control to the end that the weapon will reach the target and destroy it

SYSTEM COMPONENTS

The significant components of the major systems represented on the following diagrams are:

- Sonar Detecting-Ranging Set AN/SQS-23
 - Control-Indicator C-2708/SQ
 - Signal Data Converter CV 750/SQ
 - Azimuth and Range Indicator IP 481/SQ
 - Target Course Projector SU-2/SQ

Fire Control Group Mk 111

Attack Console Mk 38 (includes digital computer)

Position Indicator Mk 78

SEARCH MODE

The Sonar Set AN/SQS-23 is the primary ASW search, detection and localization subsystem in the ASROC weapon system. During the search mode, the "DIRECTOR CONTROL" switch (S1105) on the AN/SQS-23 CONTROL-INDICATOR (C-2708/SQ) is placed in SEARCH position. Part of the contacts on this switch are shown in Figure 111-1. In the SEARCH position, all switch circuits are open except the hold circuit of Relay K1002. Relay K1002 is presumed to be open, hence no current flows through this hold circuit. The fire control "CONTACT" relays (4A3A17K1, K2, 4A3A15K1, K2) and DIR. CONT. relays (4A3A17K3, K4) are all unenergized.

Other contacts on the "DIRECTOR CONTROL" switch (S1105) are shown in simplified one-line form in the lower left hand corner of Figure 111-4. The purpose of these contacts is to connect synchro reference circuits to the proper sources as the "DIRECTOR CONTROL" switch is used to select synchro orders from within the sonar or from fire control.

During "SEARCH", as shown in Figure 111-2, Sonar Bearing (Ba) and Range (Ra) is transmitted by synchro transmitters in the sonar to synchro Control Transformers in the Fire Control. Because fire control CONTACT relays are unenergized (Relay 4A3A17K1, K2), the error signal from the

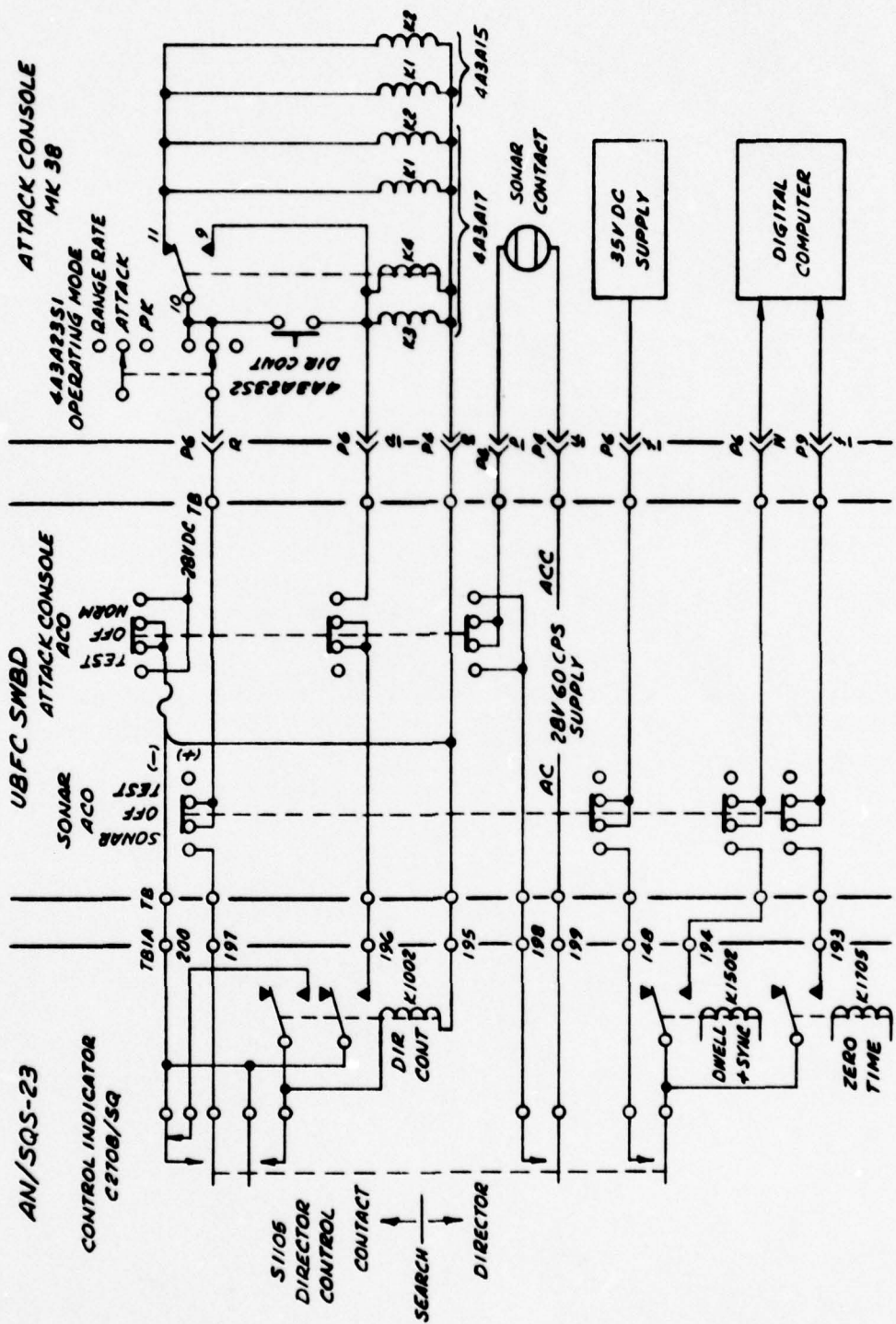

Figure 111-1. Sonar Contact and Director Control Circuits

synchro control transformers is not effective in positioning the Fire Control Bearing and Range Servos. Instead, the fire control computer positions the servos to bearing and range based on the previous problem. As shown in Figure 111-3, the fire control servos receive Bearing (qBya) and Range (qRa) correction when the sonar operator moves the handwheels. These correction values are fed into the fire control servos and positions them, however the resulting correction signals do not affect computed range and bearing.

ATTACK

As soon as the sonar operator has made a target contact which he is able to track, he may place the "DIRECTOR CONTROL" switch S1105 to CONTACT. As shown in Figure 111-1, this energizes fire control CONTACT relays (4A3A15K1, K2 and 4A3A17K1 and K2) from the 28 volt D. C. supply, if the "COMPUTER MODE" (S1) on the Mk 38 Attack Console is set to ATTACK. Placing the "DIRECTOR CONTROL" switch to CONTACT also illuminates several "CONTACT" signal lights and energizes the Dwell plus Sync Mark circuit to the digital computer. As shown in Figure 111-2, the Bearing (Ba) and Range (Ra) order from sonar now positions the corresponding servos in the Attack Console Mk 38, since error signals from the synchro control transformers are now applied to their servo amplifiers through the normally open contacts of the energized "CONTACT" relays K1 and K2. The fire control operator observes system operation and when he is satisfied with the tracking solution, he momentarily depresses DIRECTOR CONTROL pushbutton (S2) on the Mk 38 Attack Console. This pushbutton, as shown in Figure 111-1, engages the DIR. CONT. relays

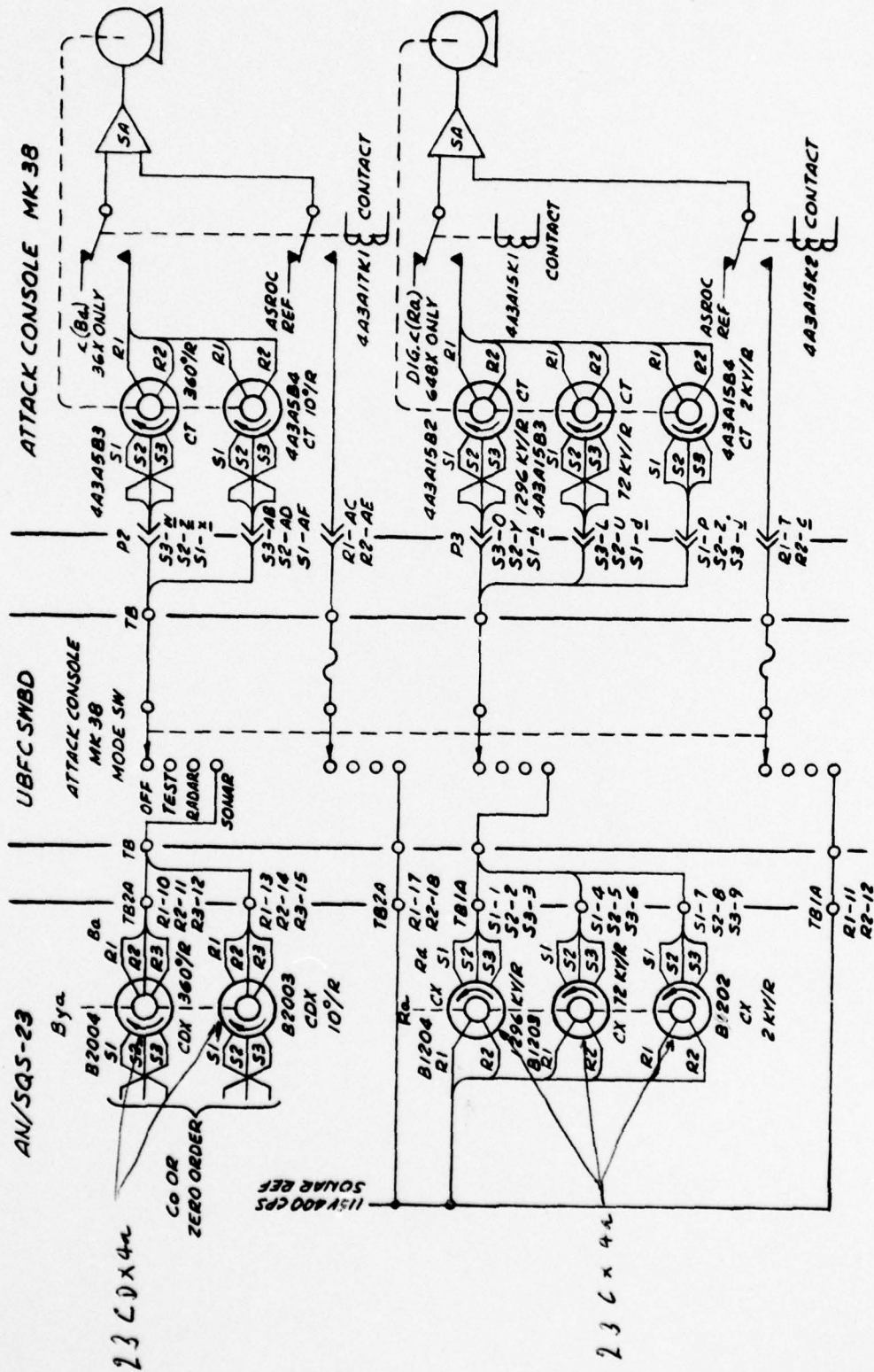

Figure 111-2. Sonar Bearing and Range to Fire Control

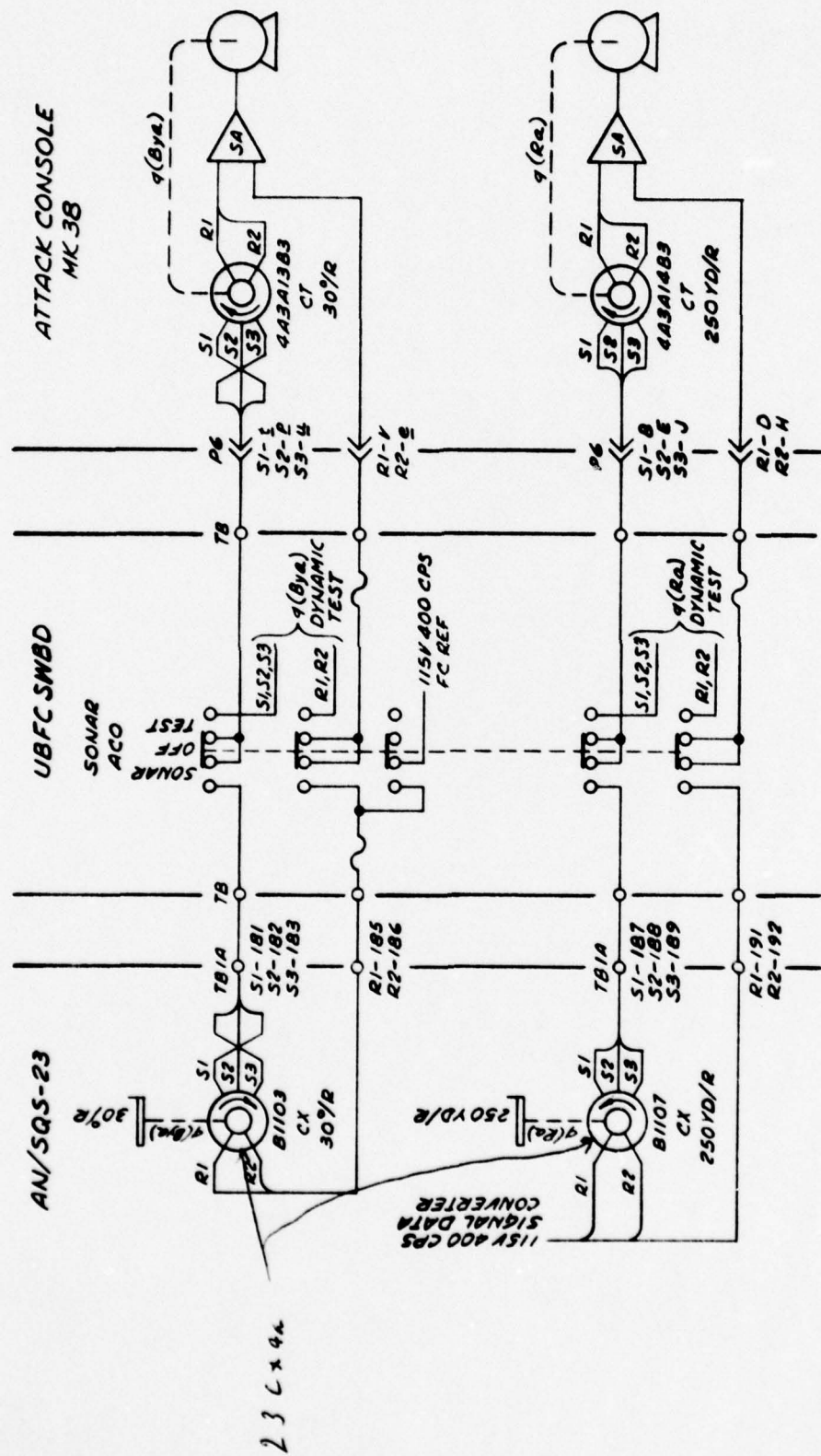

Figure 111-3. q(Bya) and q(Ra) to Fire Control

throughout the fire control equipment. Relay K4 (4A3A17) closes hold contacts to hold these relays closed. Closure of these relays places computed Range (cRa) and Bearing (cBya) on the range and bearing synchros of the AN/SQS-23 as shown in Figure 111-4 and 111-5. At the same time, the CONTACT relays open, reconnecting the Attack Console Range and Bearing Servo to computed range and bearing from the computer (See Figure 111-2). The effect of this change is to cause the Fire Control to continuously update the sonar range and bearing in response to computed data. Through synchro circuits shown in Figure 111-3, during the dwell interval, the Sonar operator enters Range and Bearing corrections directly into the computed values as he places the end of the cursor on the target, thus tracking the target until the weapon is delivered or the target is lost.

LOST CONTACT

In the case where contact is lost and the sonar operator wishes to conduct a search, the "DIRECTOR CONTROL" switch S1105 must be placed in SEARCH, prior to moving the handwheels. This action deenergizes the DIR. CONT. relays in the Attack Console, since the 28 volt DC supply is interrupted through the contacts of "DIRECTOR CONTROL" switch S1105 (Figure 111-1). The Attack Console automatically assumes a Position Keeping mode. The computer continues to compute target range and bearing based on the last contact. The sonar operator is free to search any other area. If it is desired to reinvestigate the area of last contact,

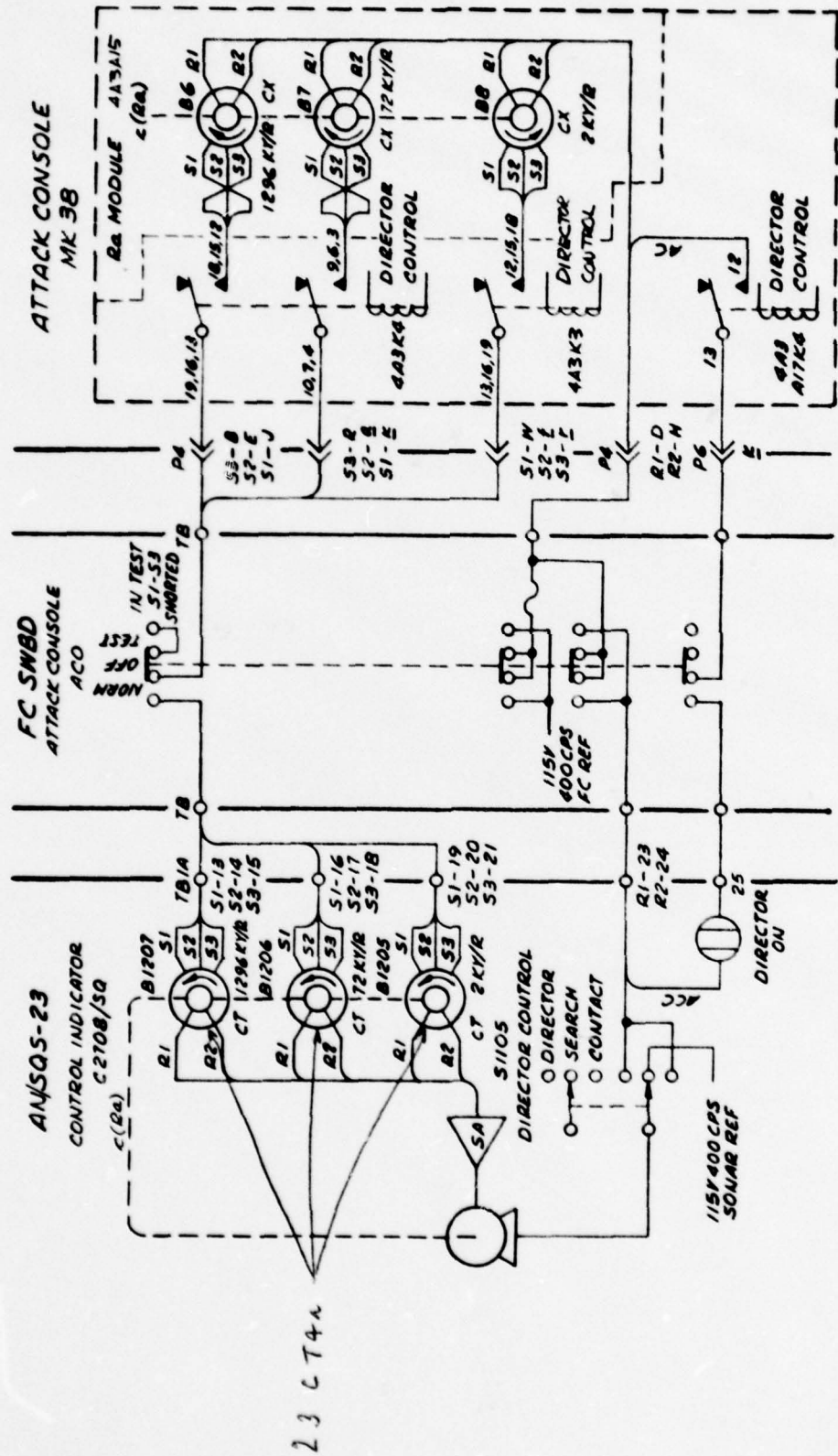

Figure 111-4. Computed Range to Sonar from Fire Control

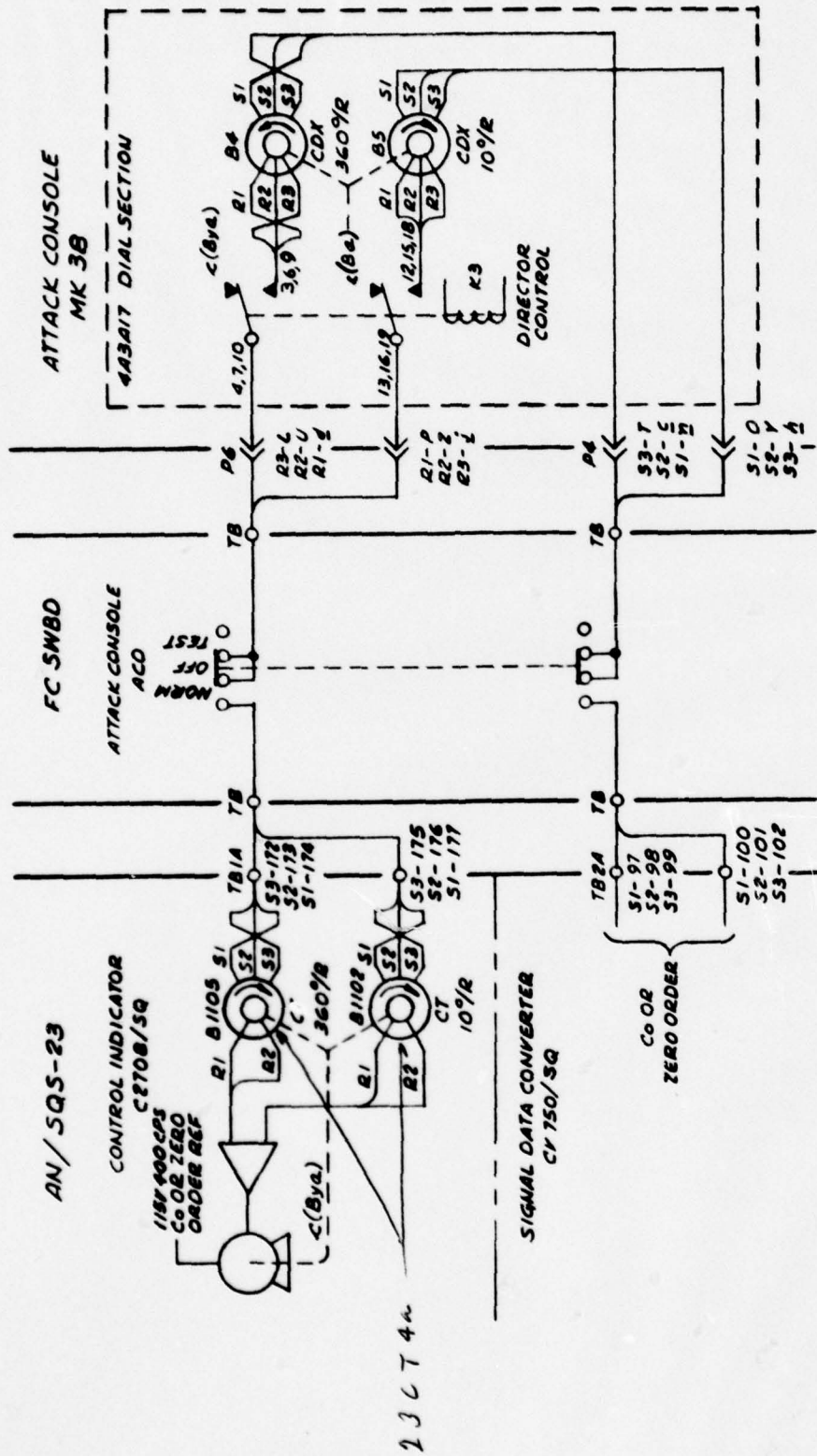

Figure 111-5. Computed Bearing to Sonar from Fire Control

momentarily placing the Sonar "DIRECTOR CONTROL" switch to DIRECTOR, will slew the sonar range and bearing to that computed by the Fire Control from the last target contact. As may be seen from Figure 111-1, this is accomplished by closure of relay K1002 in the Sonar Console which locks closed through one of its forward contacts. The other forward contact closes circuits of the DIR. CONT. Relays in the Fire Control equipment. The sonar will continue to follow the computed values which are delivered back to the sonar through the closed contacts of the DIR. CONT. relays as shown in Figure 111-4 and 111-5, even through the Sonar "DIRECTOR CONTROL" switch is returned to SEARCH since relay K1002 in the sonar is locked closed. To reestablish normal sonar search, the sonar "DIRECTOR CONTROL" switch (S1105) must be momentarily moved to CONTACT and back to SEARCH. This action opens the lock-in circuit of K1002, thereby deenergizing K1002 and the DIR. CONT. Relays in the fire control equipment.

STABILIZATION

A section of the fire control system provides for computation of stabilization orders for the sonar beam to reduce the effect of ship motion on the sonar display. The fire control accepts target Bearing (B_a) from the Sonar as shown in Figure 111-6. This bearing order is introduced into a computer which also accepts pitch and roll signals from the ship's stable element. The output or stabilized bearing train ($B_{d'a}$) is delivered to

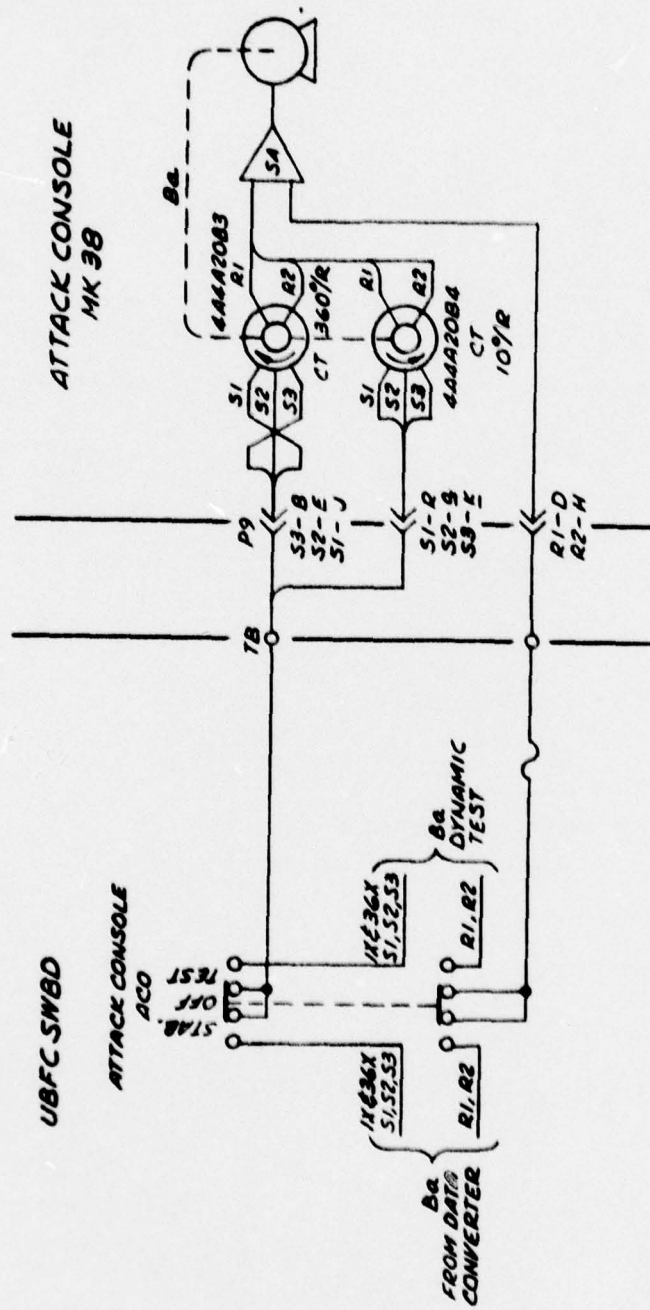

Figure 111-6. Sonar Bearing to Stabilization Computer

sonar through the fire control switchboard as shown in Figure 111-7. Relays K 2004, K 2006 provide for stabilization by-pass in case stabilization is not available. With the relays unenergized, for by-pass operation, the servo receives Bearing (Ba) directly instead of stabilized bearing train (Bda').

POSITION INDICATOR

The Position Indicator Mk 78 displays various ship and weapon quantities. To display these, Target Range (Ra) and Bearing (Ba) are received from the Sonar, as shown in Figure 111-8. Further, the Position Indicator and Fire Control both require inputs of True Bearing (Bya) to provide more required information. These are supplied from the one speed Bya synchro transmitter in the Signal Data Converter as shown in Figure 111-9. The Ct Module of the Attack Console Mk 38 adds target course to the bearing order to provide target angle (Bts) which is used by the Mk 78 to position the Target Angle Indicator. The Mk 78 accepts Bya Directly to position a ring on its Own Ship Indicator.

TARGET COURSE PROJECTOR

The Azimuth and Range Indicator (IP481/SQ) is fitted with a Target Course Projector SU2/SQ. The Target Course Projector requires a target course (Ct) order which is provided by the Attack Console Mk 38, as shown in Figure 111-10. This enables the projection of an optical cursor on to the Azimuth and Range Indicator Display to indicate target course.

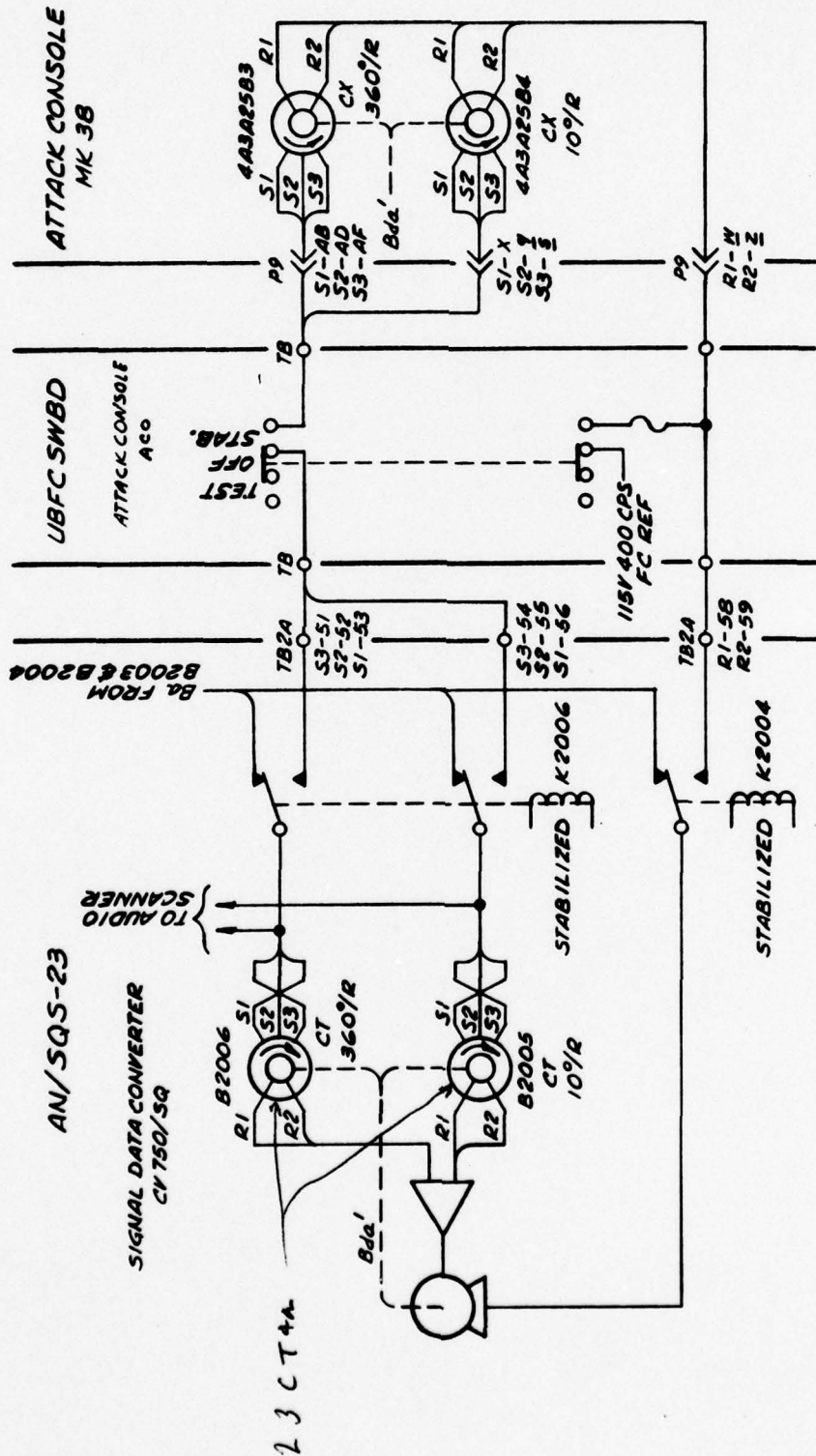

Figure 111-7. Stabilized Bearing to Sonar from Fire Control

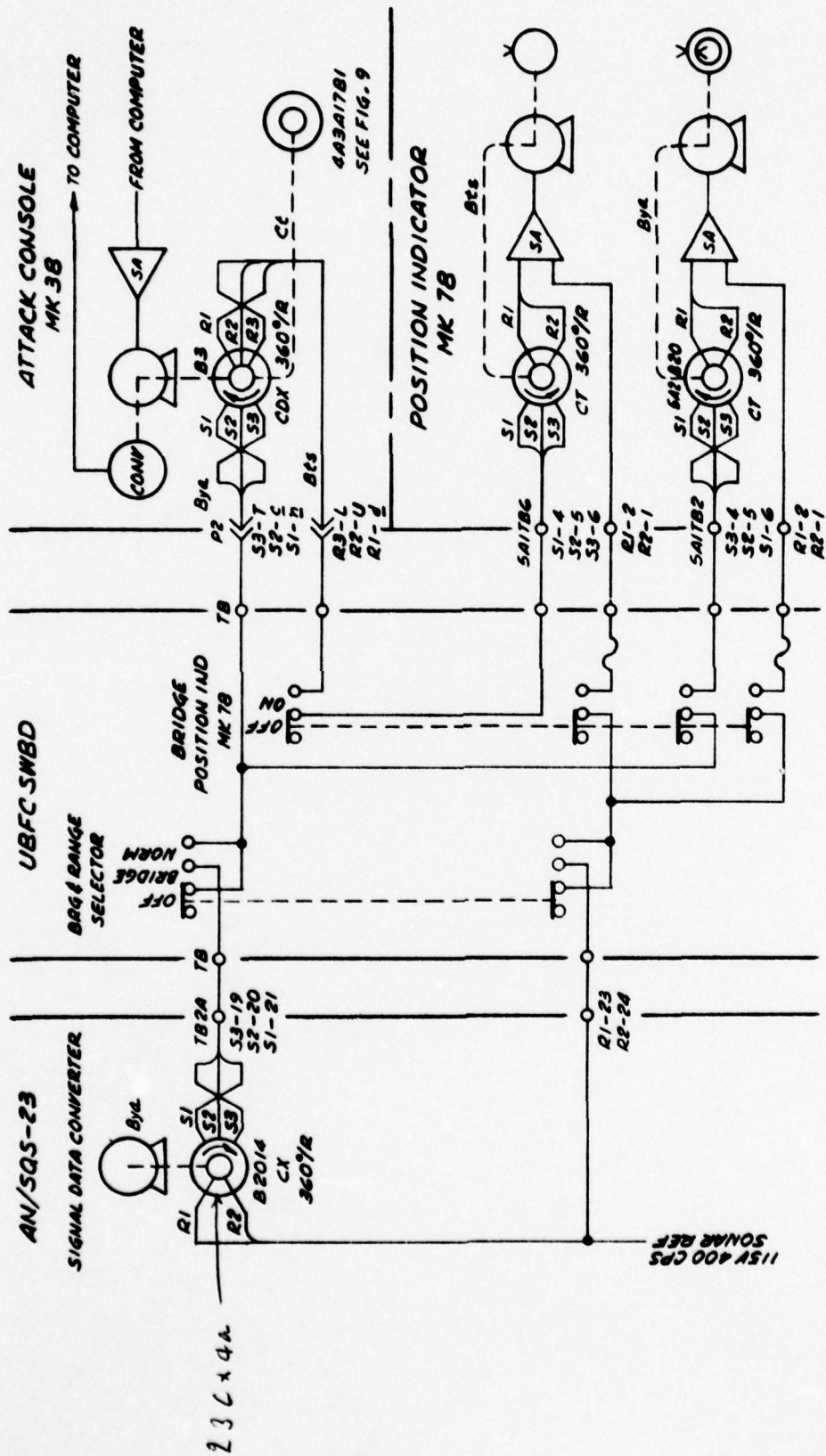

Figure 111-9. Sonar True Bearing to Fire Control and Position Indicator

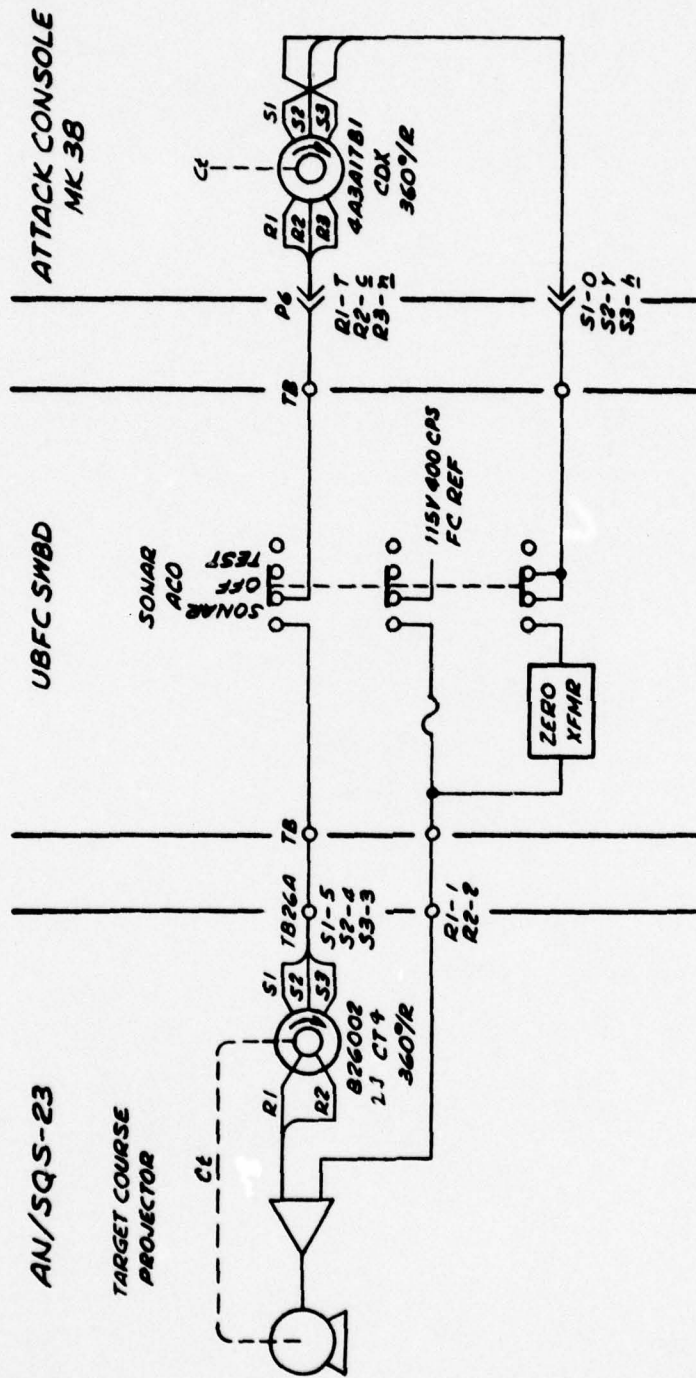

Figure 111-10. Target Course to Sonar Course Projector

FIRE CONTROL GROUP MK 114

INTRODUCTION

The Sonar Detecting-Ranging Set AN/SQS-23 is a major component of the Mk 114 ASW Weapon System. Other major components are the Fire Control Attack Console Mk 53, and several types of weapons and launchers.

1. The purpose of the Sonar Set AN/SQS-23 is to locate and track submarine targets and transmit tracking information as synchro data to the Fire Control System Mk 114.
2. The Fire Control System Mk 114, of which the Attack Console Mk 53 is a major component, computes the solution to the submarine attack problem. Fire control orders are computed and transmitted as synchro orders to launcher and weapon components
3. The system is capable of computing the attack solution for the following: torpedoes, ASROC Missile, Hedgehog, and the Drone Anti-submarine Helicopter (DASH).

SYSTEM COMPONENTS

The significant components of the major systems represented on the following diagrams are:

Sonar Detecting-Ranging Set AN/SQS-23

Control-Indicator C-2708/SQ

Signal Data Converter CV 750/SQ

Azimuth and Range Indicator 1P481/SQ

Target Course Projector SU-2/SQ

Fire Control Group Mk 114

Attack Console Mk 53

Position Indicator Mk 78

Stabilization Computer Mk 134

SEARCH MODE

The Sonar Set AN/SQS-23 is the primary ASW search, detection and localization subsystem in the ASW Weapon System. During the search mode, the "DIRECTOR CONTROL" switch (S1105) on the AN/SQS-23 CONTROL-INDICATOR (C2708/SQ) is placed in SEARCH. Part of the contacts on this switch are shown in Figure 114-1. In the SEARCH position, all these circuits are open except the hold circuits of Relay K1002. Relay K1002 is presumed to be unenergized, hence no current flows through its hold circuit. The fire control "CONTACT" (K12) "DIR. CONT." (K1, K2, K3, K4) relays are all unenergized. Other contacts on the "DIRECTOR CONTROL" Switch S1105 are represented by the contacts shown in the lower left hand corner of Figure 114-5. Their function is to transfer the synchro reference supply from internal sonar to fire control as orders are shifted to or from fire control.

During SEARCH, as shown in Figure 114-2 and 114-3 Sonar Range (Ra) and Bearing (Ba) are transmitted by synchro transmitters in the sonar to synchro control transformers in the Fire Control Attack Console. Because the fire control CONTACT relays (K1, K2 and Figure 114-2; K1 Figure 114-3) are unenergized, the error signal from the control transformers is not effective in positioning the servos. As shown in Figure 114-4, the handwheel rotation of the sonar operator for both bearing (q(Bya)) and range (q(Ra)) are transmitted to corresponding servos in the Attack Console.

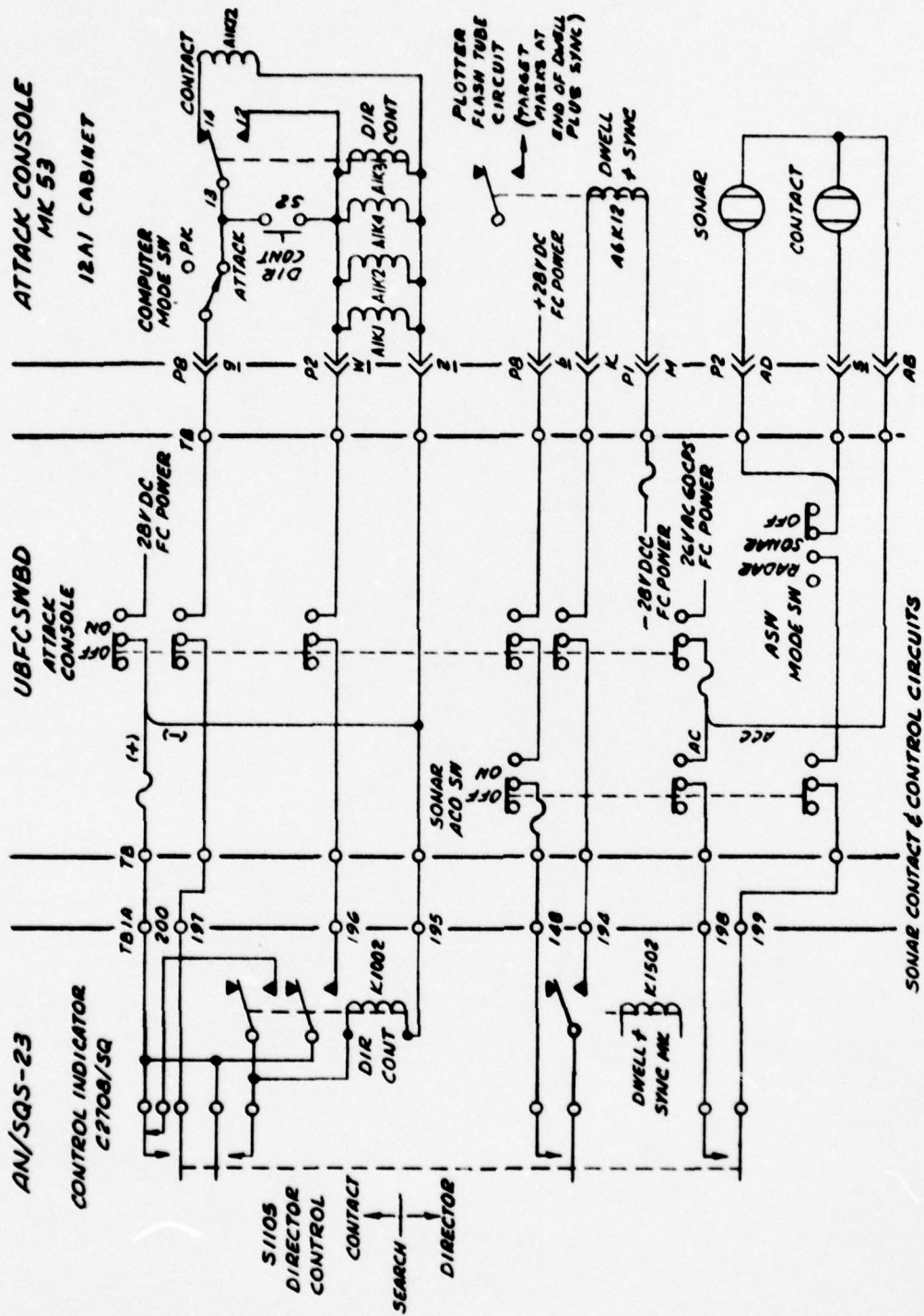

Figure 114-1. Sonar Contact and Control Circuits

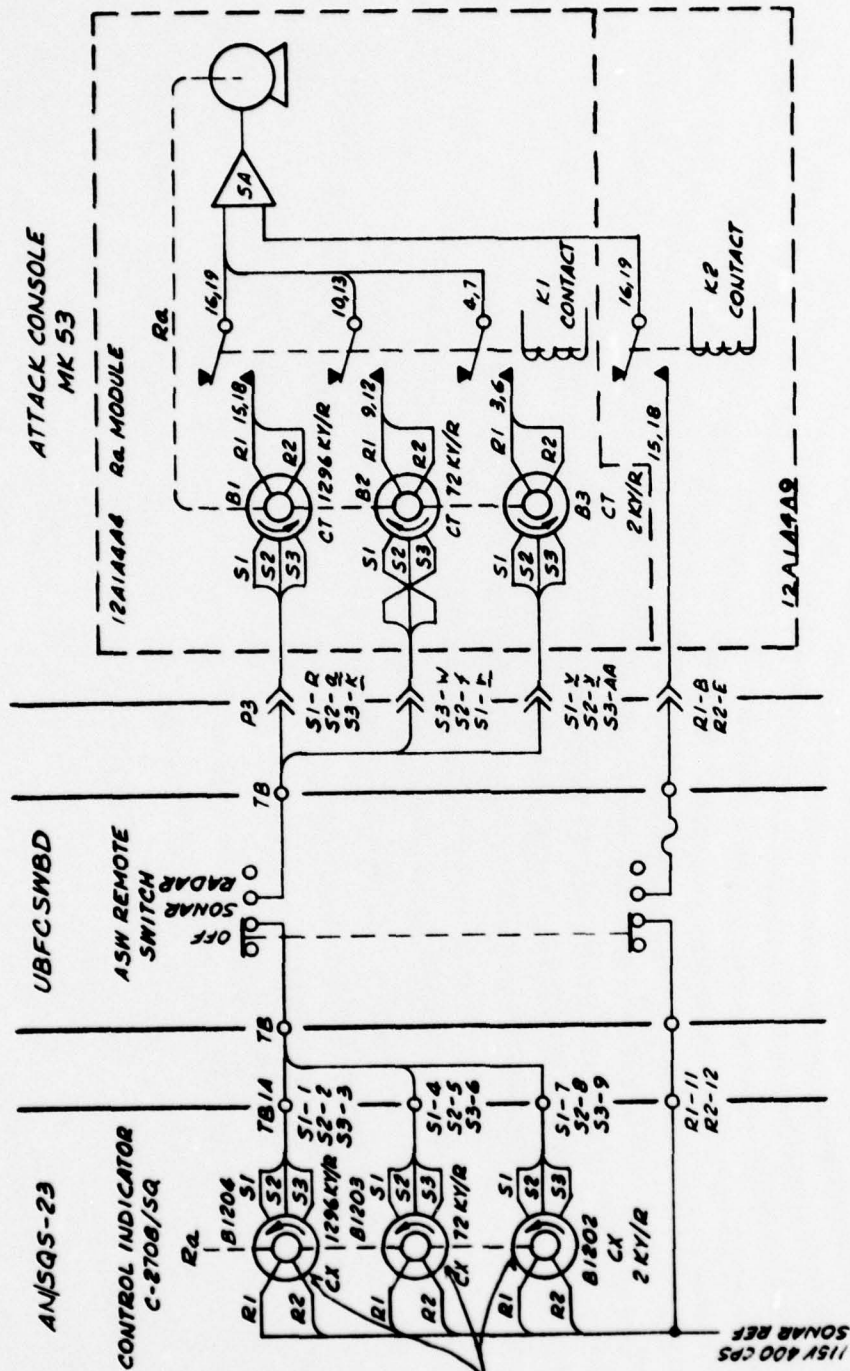

Figure 114-2. Sonar Range to Fire Control

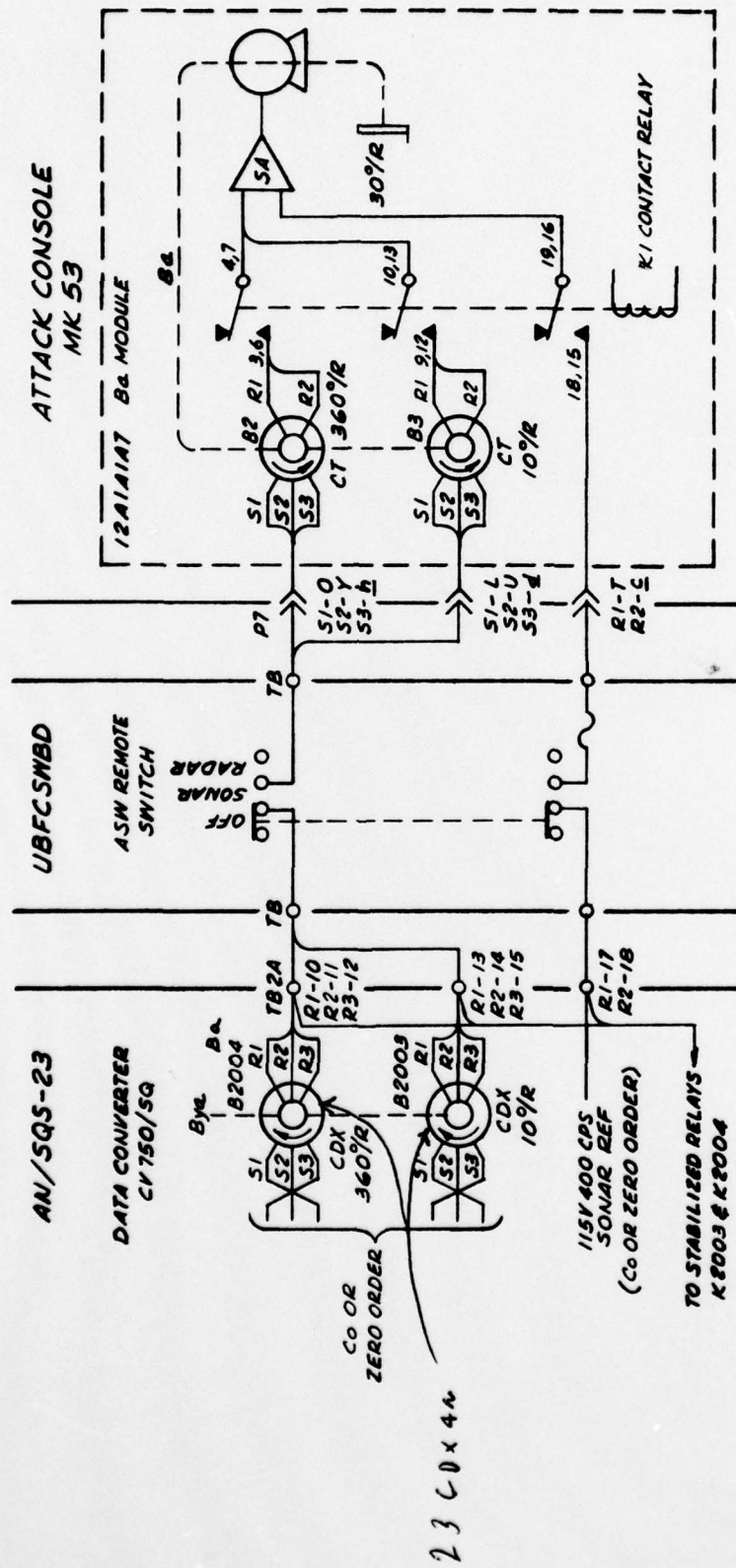

Figure 114-3. Sonar Bearing to Fire Control

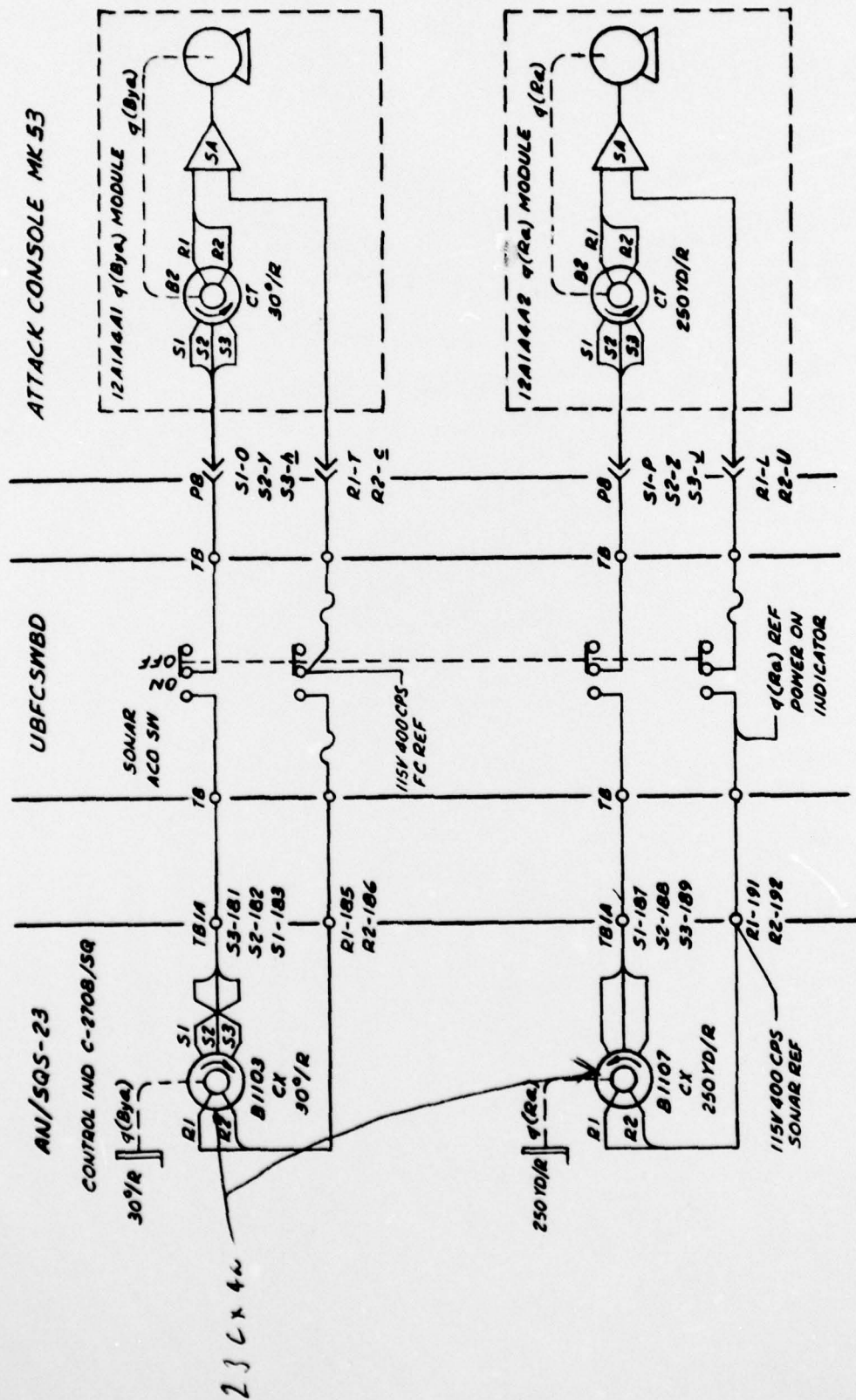

Figure 114-4. q(Bya) and q(Ra) from Sonar to Fire Control

These servos are energized and position the synchro control transformers to follow the orders received, however these servos do not affect the problem computation at this time.

ATTACK

As soon as the sonar operator has made a target contact which he is able to track, he may place the "DIRECTOR CONTROL" switch S1105 to CONTACT. As shown in Figure 114-1, this energizes the contact relay A1K12 in the Attack Console Mk 53 from the 28 volt DC supply, if the "COMPUTER MODE" switch is set to ATTACK (on the Attack Console). Placing the "DIRECTOR CONTROL" switch to CONTACT also illuminates several indicators alerting the Fire Control Operator and others that a Sonar contact has been made. As the sonar operator tracks the target the DWELL and SYNC relay K1502 in the sonar set causes the DWELL and SYNC MARK relay (A6K12) in the Attack Plotter to close at each dwell and sync period, thereby plotting a point on the Attack Console screen. As shown in Figure 114-2 and 114-3, energization of CONTACT relays K1 and K2 causes the error signal from the Ra and Ba synchro control transformers to be applied to their respective servo amplifiers. The servos rapidly position synchro control transformers to match the Sonar target range and bearing orders.

The fire control operator observes system operation and when he decides that useful data is being received he may depress the "DIR. CONT." push-button (S2-Figure 114-1) on the Attack Console. This closes all "DIR. CONT." relays (K1, K2, K3, K4). K3 locks the circuit closed through contacts 12 and 13. The CONTACT relay (K12) opens due to the circuit interruption at the back contact, 14, of relay K3 (Figure 114-1). The

energized "DIR. CONT." relays as shown in Figures 114-5 and 114-6 connect the computed Range (cRa) and Bearing (cBya) orders from the synchro transmitters in the Attack Console Mk 53 to the synchro control transformers in the Sonar Control Indicator to position the range and bearing cursor in the sonar display, thereby updating the position of the cursor or the target track in response to the fire control solution. Through the correction synchro orders (q(Bya)) and (q(Ra)) shown in Figure 114-4, the sonar operator can insert manual corrections during the sonar dwell period to position the end of the cursor on the target. This correction is inserted into the fire control computation, and display through the Attack Console q(Bya) and q(Ra) servos. The attack should now proceed in this mode until the weapon is delivered or contact is lost.

LOST CONTACT

In the case where contact is lost and the sonar operator wishes to conduct a search, the "DIRECTOR CONTROL" switch S1105 must be placed in SEARCH, prior to moving the handwheels. This action deenergizes the DIR. CONT. relays in the Attack Console, since the 28 volt DC supply is interrupted through the contacts of "DIRECTOR CONTROL" switch S1105 (Figure 114-1). The Attack Console automatically assumes a Position Keeping mode. The Attack Console holds the range and bearing of the last contact and continues to compute target course based on the last data.

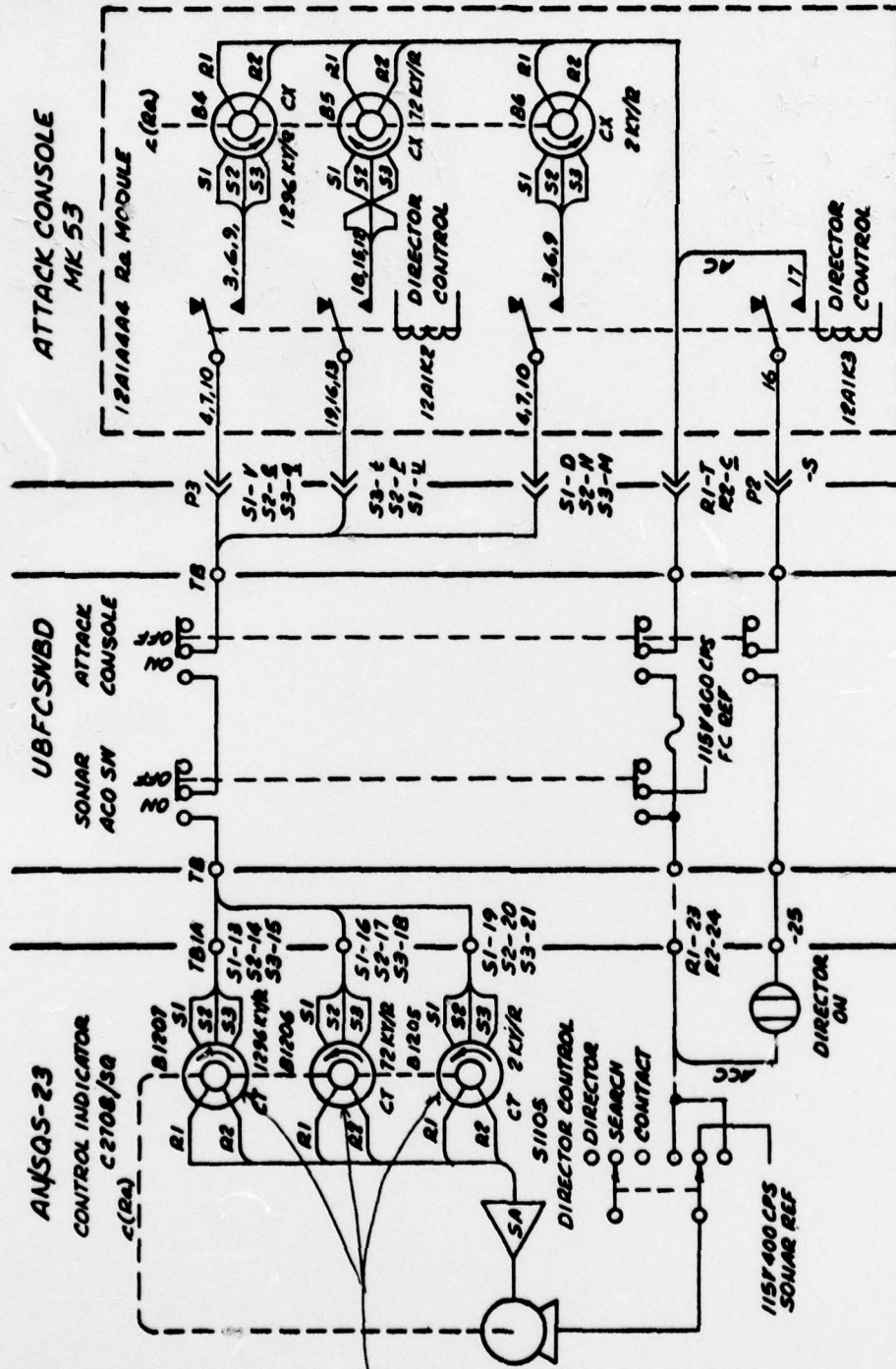

Figure 114-5. c(Ra) from Fire Control to Sonar

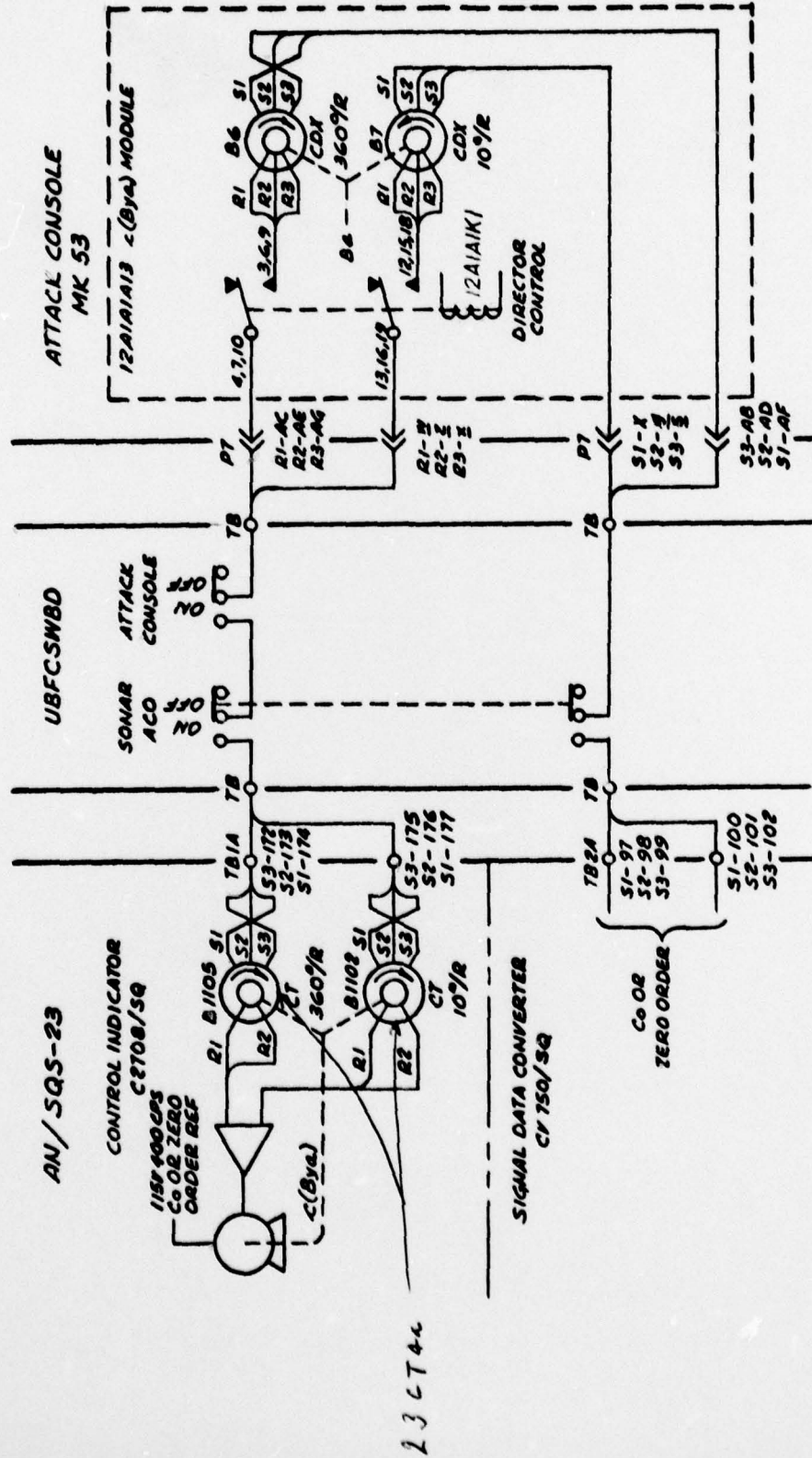

Figure 114-6. c(Bya) from Fire Control to Sonar

The sonar operator is free to search for the target as before. If it is desired to reinvestigate the area of the lost target, the sonar operator may hold the "DIRECTOR CONTROL" switch S1105 to DIRECTOR. This immediately slews the sonar range and bearing to that computed by Fire Control from the last target contact. As shown in Figure 114-1, momentarily placing the "DIRECTOR CONTROL" switch S1105 in DIRECTOR closes relay K1002 which locks closed through contacts 2 and 4. Contacts 1 and 3 of this relay closes the DIR. CONT relay circuits in the fire control, thereby connecting the sonar range and bearing synchro control transformers to the corresponding synchro transmitter in the Attack Console Mk 53 as shown in Figures 114-5 and 114-6. The Sonar will remain slaved to fire control until the operator momentarily places the "DIRECTOR CONTROL" switch to CONTACT and then returns it to SEARCH. This action opens the normally closed contact on S1105 shown as top contact in Figure 114-1. This deenergizes K1002 and the fire control DIR. CONT. relays and permits the sonar train to return to SEARCH mode as soon as the "DIRECTOR CONTROL" switch is returned to SEARCH position.

STABILIZATION

The Mk 134 Stabilization Computer generates synchro signals which correct for the effect of ship motion on sonar bearing train. The stabilization computer receives synchro orders corresponding to ship's motion quantities from the stable element, and sonar target bearing (Bya) synchro orders from the Sonar Data Converter as shown in Figure 114-7. The Stabilization Computer computes the necessary corrections and transmits the corrected bearing train order (Bda') to Sonar as shown in Figure 114-8. In case stabilization is not available, relays K2004, 6 open and unstabilized bearing orders (Bya) are applied in place of stabilized bearing (Bda').

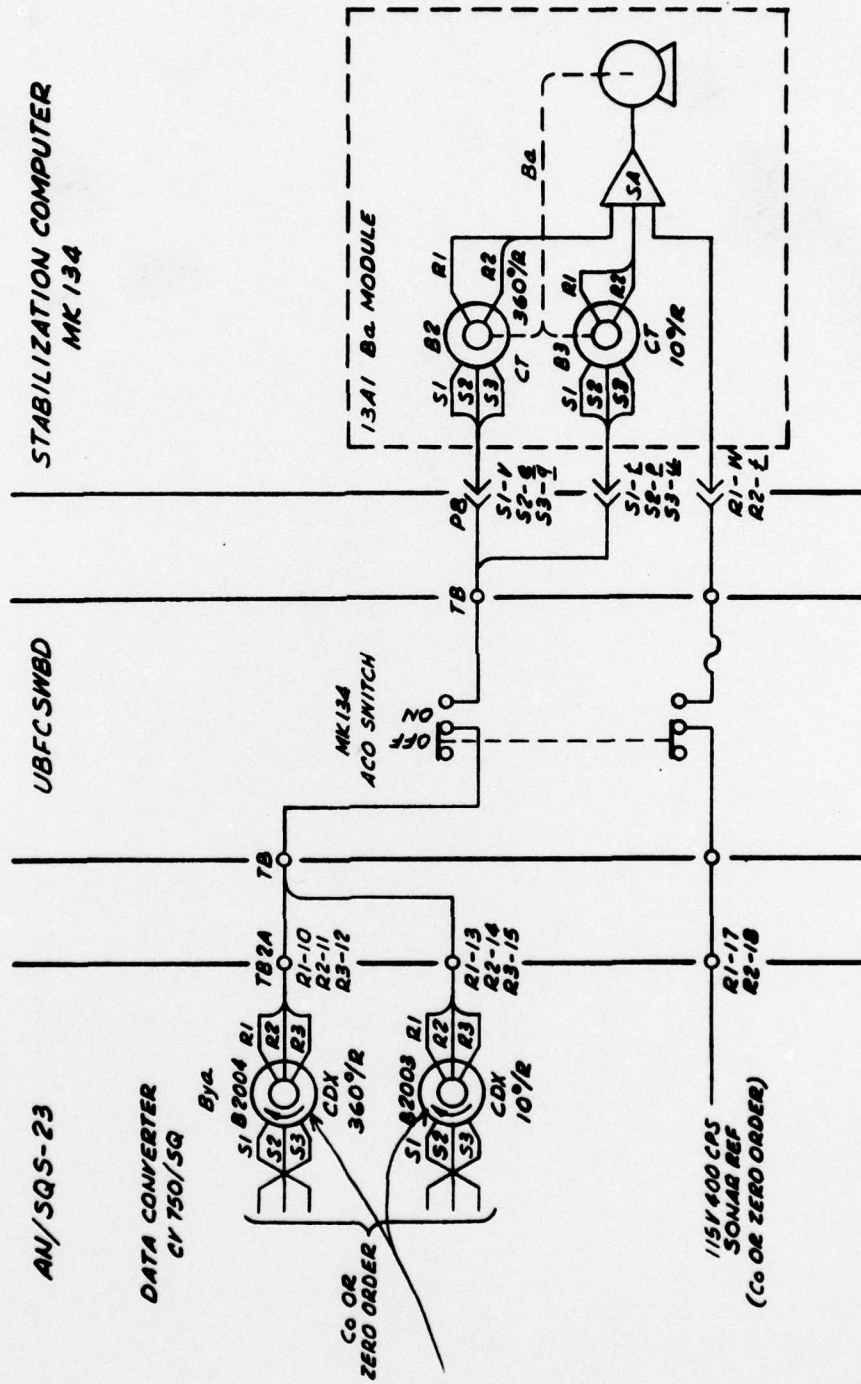

Figure 114-7. Sonar to Stabilization Computer Mk 134

POSITION INDICATOR

The Position Indicator Mk 78 displays various ship and weapon quantities. Some of the inputs are derived directly from sonar, some from the fire control system. Figure 114-9 shows bearing (Ba) and Range (Ra) orders which are sent directly from the Sonar to the Position Indicator. The Position Indicator displays bearing on a concentric dial and range on an in-line digital display. Figure 114-10 shows Sonar Target True Bearing (Bya) transmitted to the Mk 78 Position Indicator for display on a dial concentric with the relative bearing (Ba) dial. Target Angle (Bts) is displayed on a separate dial and is derived directly from the Bts module in the Mk 53 Attack Console as shown in Figure 114-10.

TARGET COURSE PROJECTOR

The Azimuth and Range Indicator (1P481/Sq) is fitted with a Target Course Projector SU2/SQ. The Target Course Projector accepts a target course order (Ct) as provided by the Ct module in the Mk 53 Attack Console. This arrangement is shown schematically in Figure 114-11.

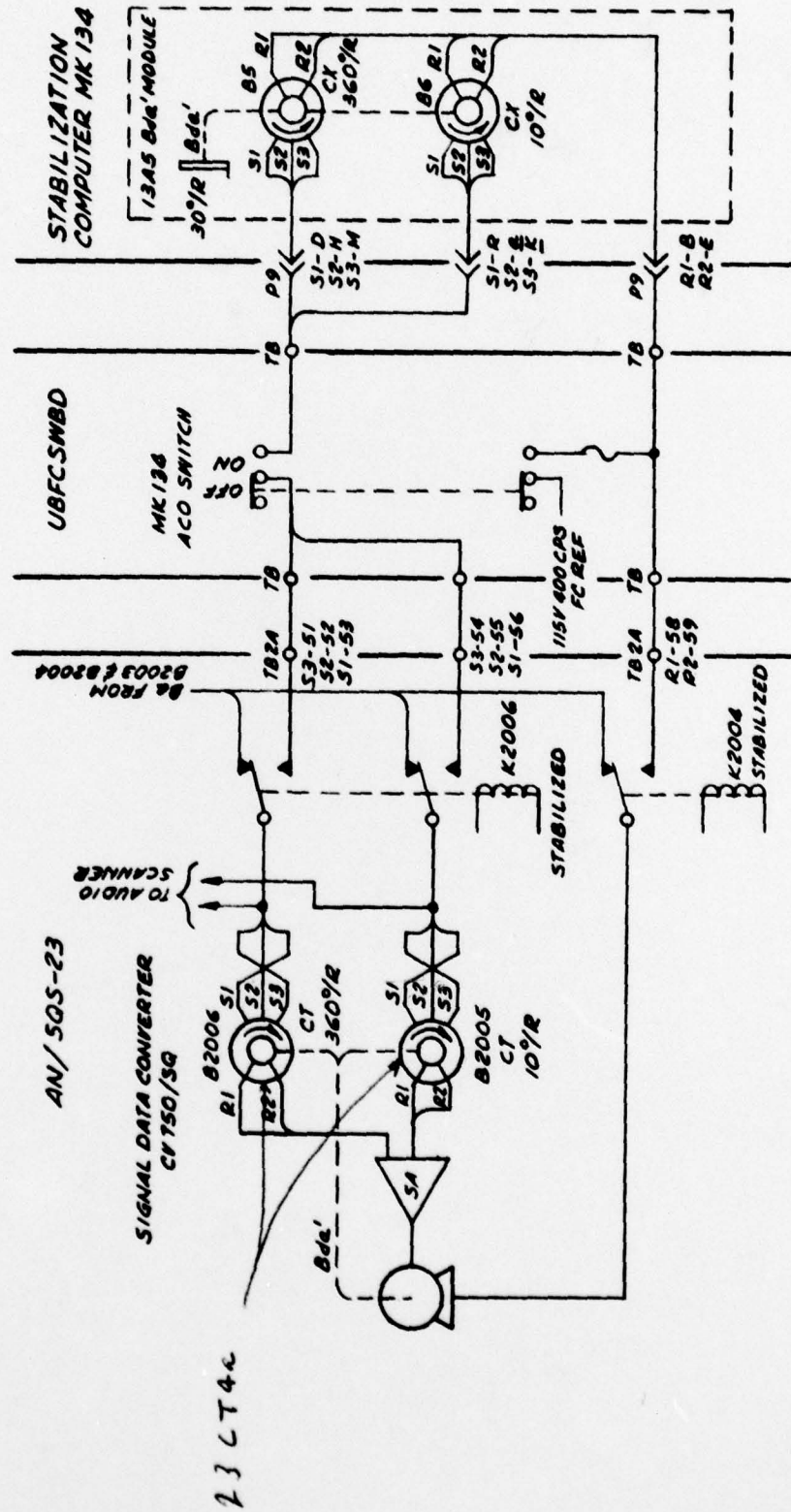

Figure 114-8. Stabilization Computer to Sonar

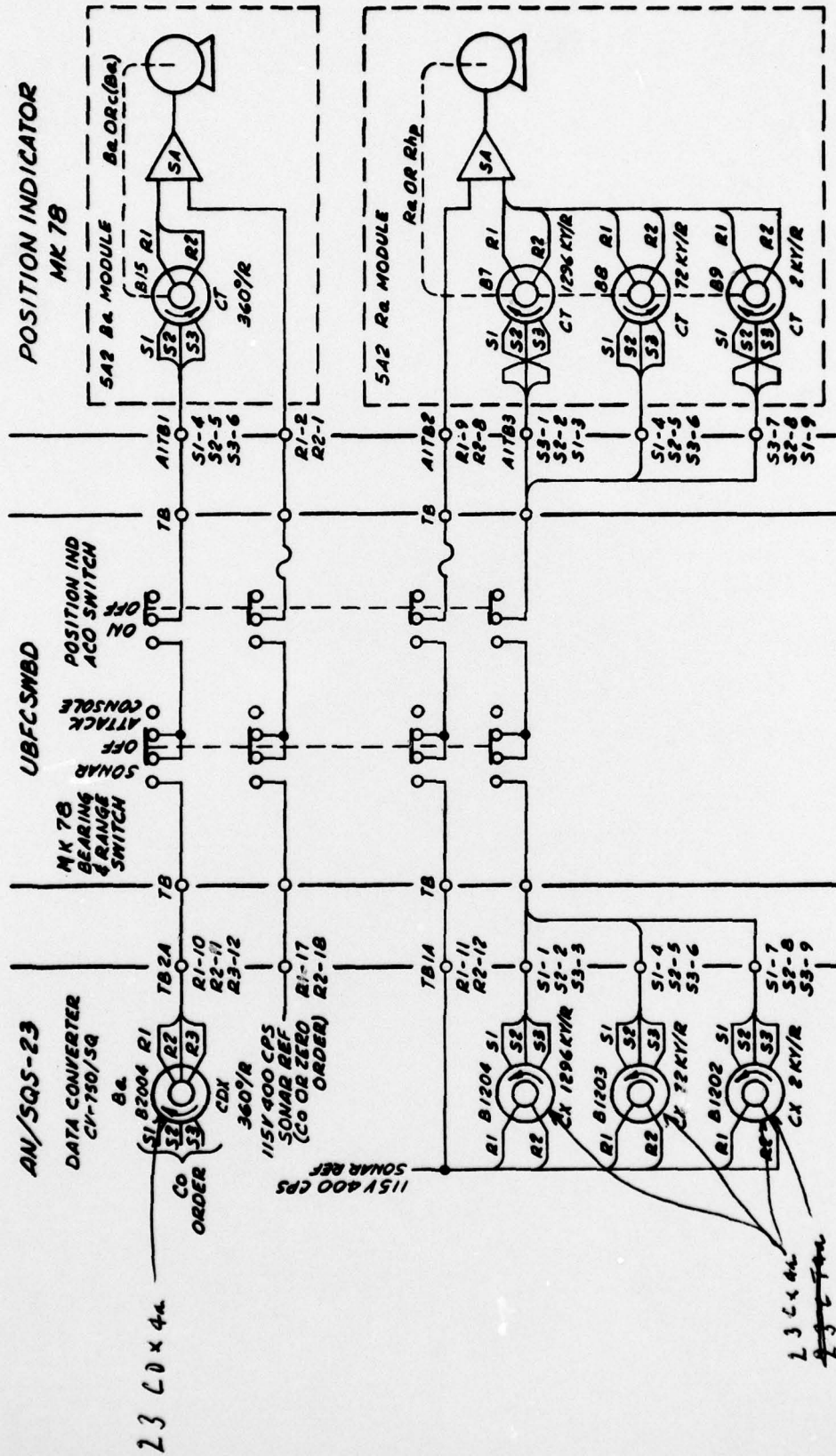

Figure 114-9. Sonar Range and Bearing to Position Indicator

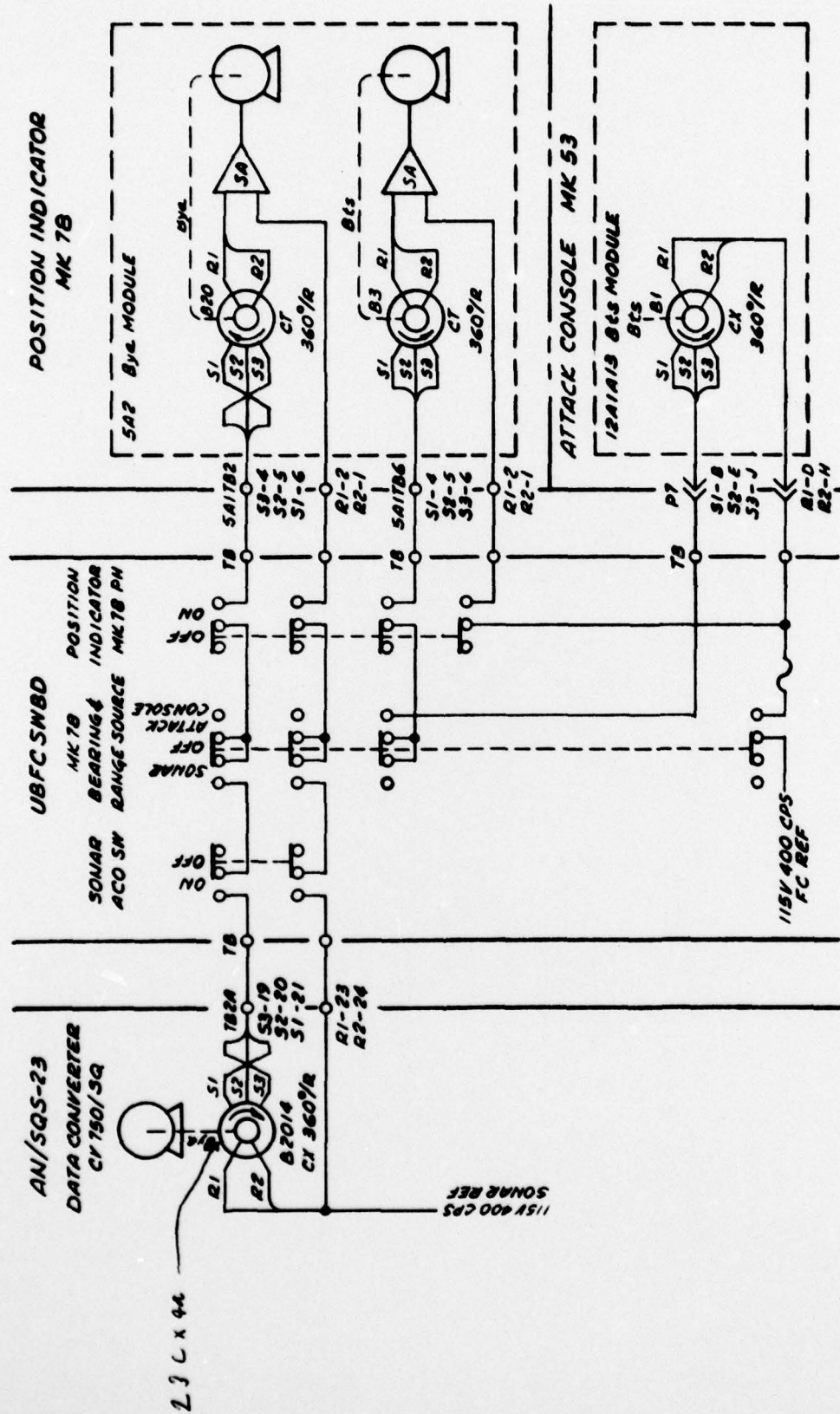

Figure 114-10. Sonar to Fire Control and Position Indicator

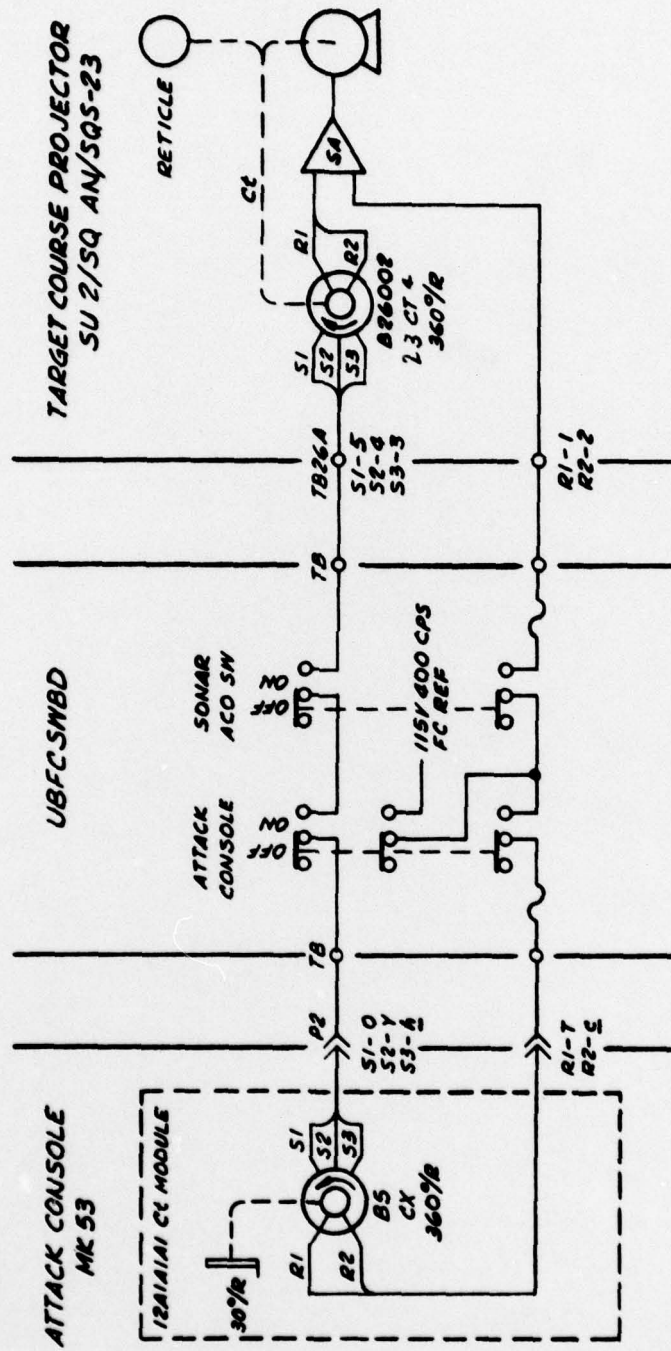

Figure 114-11. Fire Control to Sonar Target Course Projector

LIBRASCOPE GROUP

 **GENERAL
PRECISION**

808 WESTERN AVE. • GLENDALE 1, CALIFORNIA