

AD-A068 966

ORION RESEARCH INC CAMBRIDGE MASS

F/G 13/2

DEVELOPMENT OF CONTOC MONITOR.(U)

DEC 78 S WEST, A TERRY, J CHRISOS, G CHRYSIS DAAG53-76-C-0167

UNCLASSIFIED

NL

| OF |
AD
A068966



END
DATE
FILMED
6-79
DDC

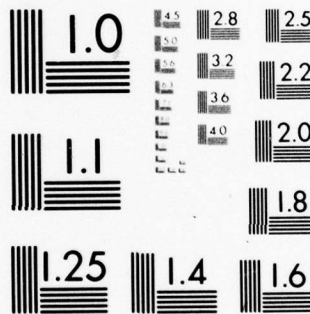

MICROCOPY RESOLUTION TEST CHART
NATIONAL BUREAU OF STANDARDS 1963-A

LEVEL II

ORION RESEARCH



AD A 068966

DDC FILE COPY

Final Report: Contract DAAG-53-76-C-0167

"Development of CONTOC Monitor"

Authors: Steven West, Ann Terry,
John Chrisos, George Chryssis

Submitted to MERADCOM, Fort Belvoir, Va.

Approved for Public Release
Distribution Unlimited

a whole new
technology for
chemical measurement

DDC
RECEIVED
MAY 23 1979
REGISTRY
D

LEVEL II

(1)

DAAG-53-76-C-0167

(6) Development of CONTOC Monitor

(9) Final Report and Instruction Manual
December, 1978

(11)

(12) 8LP

(15) DAAG 53-76-C-0167

(10)

Authors: Steven West, Ann Terry, John Chrisos, George Chryssis

| | |
|-------------------------------------|---------------|
| ADMISSION for | |
| <input checked="" type="checkbox"/> | White Section |
| <input type="checkbox"/> | Buff Section |
| <input type="checkbox"/> | UNCLASSIFIED |
| <input type="checkbox"/> | JUSTIFICATION |
| BY _____ | |
| DISTRIBUTION/AVAILABILITY CODES | |
| Dist. AVAIL. and/or SPECIAL | |
| A | |

Orion Research, Inc.
380 Putnam Avenue
Cambridge, Ma. 02139

DDC
RECEIVED
MAY 23 1979
D

79 05 17 015

DISTRIBUTION STATEMENT A
Approved for public release;
Distribution Unlimited

392 199

JOB

Table of Contents

| | |
|--------------|---|
| Chapter 1. | Introduction |
| Chapter 2. | The Measurements |
| Chapter 3. | System Description: Mechanical Photo Section |
| Chapter 4. | System Description: Electronic |
| Chapter 5. | Pre-delivery Test Results |
| Chapter 6. . | Conclusion |
| | Instruction Manual |

79 05 17 015

CHAPTER 1. INTRODUCTION

The development of the CONTOC monitor arose from the need for continuous on-line analysis of treated effluent waters from munitions plants. The specific conductance (SC), organic nitrate (ON) and total organic carbon (TOC) content are considered critical indications of the effectiveness of the waste treatment process. This report describes the development of an instrument capable of automatic unattended recording of these three (3) parameters.

Our work was conducted in two (2) phases. The principal goal of the first phase was to develop the chemistry for a continuous ON measurement. We proposed that UV-peroxydisulfate oxidation of organic nitrate containing compounds might produce nitrate ions which could then be measured by a nitrate ion-selective electrode. This concept arose out of previous work by Orion in the development of a continuous UV-peroxydisulfate TOC analysis (NASA Contract NAS-14229). We did not succeed in developing the UV oxidation method for ON for reasons described in Chapter 2. As an alternative we then investigated a polarographic approach and were able to design a viable technique.

The second phase of effort consisted of integrating the SC, ON, and TOC systems into an industrial piece of hardware. The goal of this work was to produce an instrument which could provide rapid response to changing levels of these species with a minimum of expendable consumption and maintenance.

Chapter 2 describes the theory of each measurement and includes the results of our work on the UV approach to the ON determination. An overall description of the fluidic and electronic systems is contained in Chapters 3 and 4. The results of in-house testing at Orion and our recommendations regarding future work are in Chapters 5 and 6. An operations manual is included as Appendix.

CHAPTER 2. THE MEASUREMENTS

The three (3) CONTOC analyses utilize three (3) different types of electrochemical measurement techniques - conductimetric, polarographic (amperometric) and potentiometric. In this chapter each measurement is discussed in turn and in relation to the specific design requirements of this application.

Specific Conductance

Specific Conductance is the simplest measurement in the CONTOC monitor. This is true not only because the electrochemical and electronic techniques are long established but also because the sample solution requires no prior treatment. This means that the location of the actual cell in the fluidic system is flexible and therefore easily integrable with the ON and TOC systems.

The conductivity cell itself consists of two (2) 6 mm lengths of 0.75mm I.D. thin-walled platinum tubing which are potted by a "lost-epoxy" technique into an acrylic block. The entire assembly is 3 x 3 x 1 cm. The sample solution passes through the platinum tubes in series.

The electronics used in the conductivity measurement is described in Chapter 4.

Organic Nitrate (ON)

The development of the chemistry for the ON measurement was the principal task in this effort. In our original proposal, we indicated that the determination of organic nitrate might be accomplished by means of UV catalyzed oxidation of nitro or nitrate ester groups to nitrate ions and subsequent determination using a nitrate selective electrode. In our work on the determination of TOC for NASA (Contract NAS-9-14229), the technology for the continuous on-line oxidation of organic compounds was developed and reduced to practice. The combination of peroxydisulfate ion ($S_2O_8^{=}$) and UV light of wavelength 253.7 nm was proven to be effective

in oxidizing thirty test compounds of widely varying functional classifications, such that quantitative recovery of TOC as CO_2 was observed. Two of these compounds, nitrobenzene and picric acid, contain nitro groups, and are similar in structure to TNT and related compounds. Under the highly oxidizing conditions of this process, it was felt that the nitro groups ($-\text{NO}_2$) would be converted to nitrate ion (NO_3^-) resulting in the net reaction shown in equation (1).

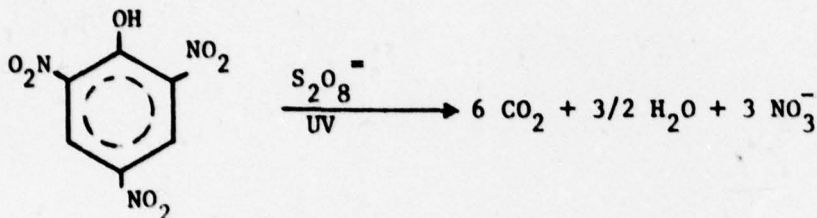

The initial experimental set-up to test the conversion of nitro groups to NO_3^- is shown schematically in Figure 2.1. These experiments indicated that the persulfate ion, $\text{S}_2\text{O}_8^{2-}$, interfered with the NO_3^- electrode to such an extent that NO_3^- could not be detected at the levels of interest.

TABLE 2.1

Persulfate Interference on Nitrate Electrodes

| Solution | Nitrate Electrode Potential (mv) |
|---|----------------------------------|
| $10^{-1}\text{M}(\text{NH}_4)_2\text{SO}_4$ | +238 |
| $10^{-1}\text{M}(\text{NH}_4)_2\text{SO}_4, 10^{-5}\text{M NaNO}_3$ | +228 |
| $10^{-1}\text{M}(\text{NH}_4)_2\text{SO}_4, 10^{-4}\text{M NaNO}_3$ | +188 |
| $10^{-1}\text{M}(\text{NH}_4)_2\text{SO}_4, 10^{-3}\text{M NaNO}_3$ | +132 |
| $10^{-1}\text{M}(\text{NH}_4)_2\text{SO}_4, 10^{-3}\text{M NaNO}_3, 10^{-4}\text{M}(\text{NH}_4)_2\text{S}_2\text{O}_8$ | +109 |
| $10^{-1}\text{M}(\text{NH}_4)_2\text{SO}_4, 10^{-3}\text{M NaNO}_3, 10^{-3}\text{M}(\text{NH}_4)_2\text{S}_2\text{O}_8$ | +87 |
| $10^{-1}\text{M}(\text{NH}_4)_2\text{SO}_4, 10^{-3}\text{M NaNO}_3, 10^{-2}\text{M}(\text{NH}_4)_2\text{S}_2\text{O}_8$ | +57 |

In the UV oxidation step, only about 60% of the persulfate is consumed. Thus, in order to measure nitrate ion, the residual persulfate had to be decomposed. Table 2.1 contains data showing the degree of the persulfate

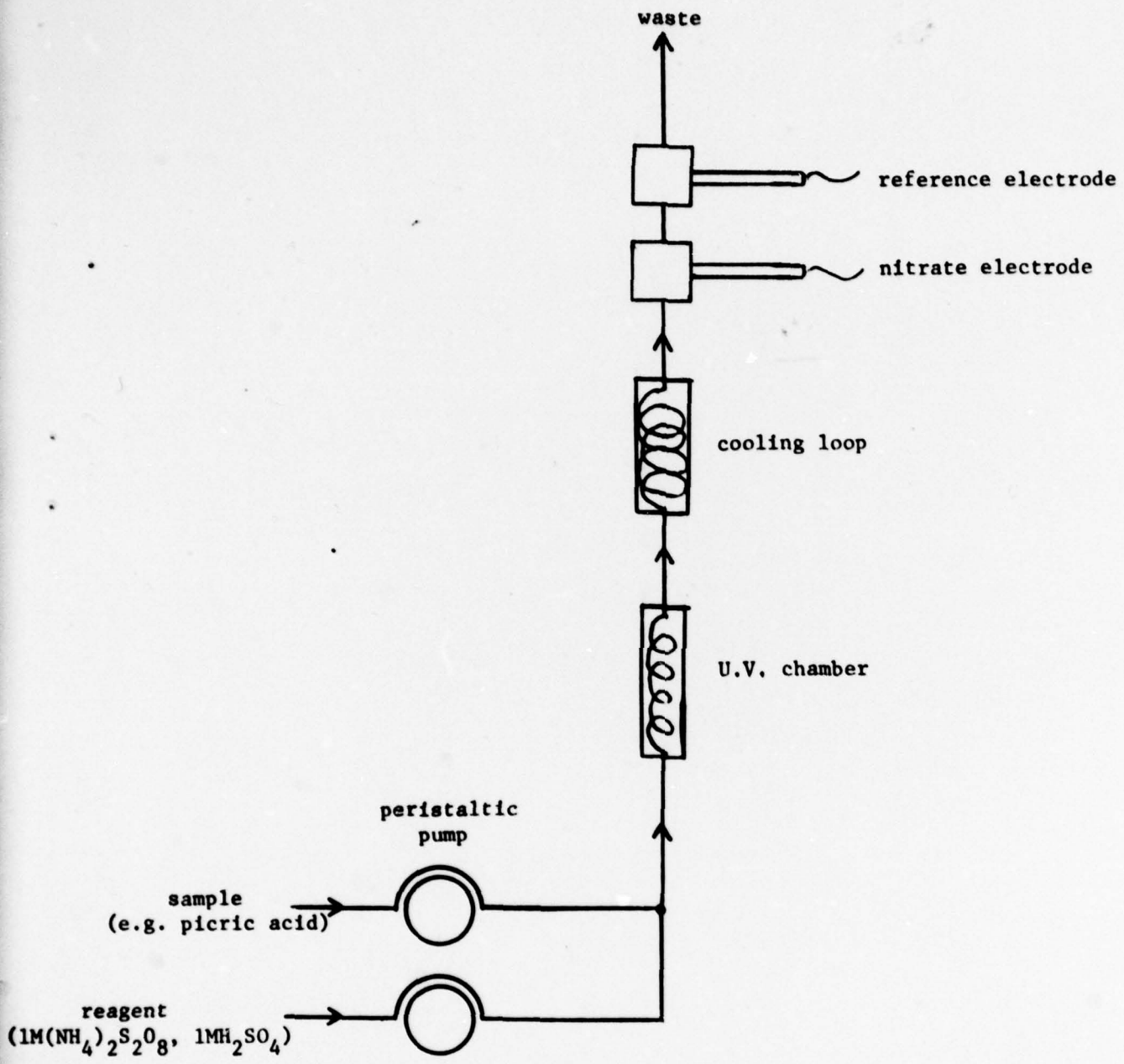

Figure 2.1 U.V. Oxidation Experiment

interference on the nitrate electrode. The purpose of $(\text{NH}_4)_2\text{SO}_4$ as a background in the solutions was to duplicate the matrix conditions in which we desired to measure nitrate. It can be seen in the table that, in the absence of persulfate, the electrode responded normally to the increased nitrate concentrations. At 10^{-3}M the slope approached 59 mv/decade, which is the theoretical Nernstian response for a monovalent anion. However, addition of 10^{-4}M persulfate caused a large error in apparent nitrate concentration. As the persulfate concentration reached 10^{-2}M , the Nernstian 29 mv/decade response to a divalent ion was observed. This data demonstrated that excess persulfate ion from the oxidation step needed to be decomposed quantitatively.

A number of reducing agents were evaluated for elimination of residual persulfate. It was hoped that a species could be found which, when added to the sample stream after oxidation, would react with the persulfate rapidly enough to be useful in a continuous monitoring application. The nitrate electrode has other interferences as well as pH limitations, so the choice of reductants was narrowed to those that have sufficient solubility at an appropriate pH, and that would not introduce other interfering species into solution. Also, the eventual integration of the organic nitrate system with the TOC system had to be considered. We evaluated Fe^{++} , Mn^{++} , Sn^{++} , N_2H_2 , HCHO , H_3AgO_3 and NaH_2PO_2 as reductants but none eliminated the interference to a manageable extent.

As an alternative to the direct measurement of nitrate, we evaluated a method for the reduction of nitrate ion to nitrite ion, and subsequent measurement of nitrogen oxide with a gas-sensing electrode. This method is used in our industrial NO_3^- monitor. Although in this method, the excess oxidant must also be reduced to permit the reduction of NO_3^- to NO_2^- , it was felt that the destruction of the oxidant need not be so complete as in the direct nitrate measurement. An additional advantage to this method was that the nitrogen oxide gas sensing electrode does not have as many potential interferences as the nitrate electrode. The disadvantage to this method was the added complexity and number of reagents necessary.

A flow-scheme for this method is shown in Figure 2.2. The sample is first combined with the oxidant and is exposed to the UV radiation. In this step the organic nitrate compound is presumed to be oxidized to CO_2 and NO_3^- . After irradiation the sample is combined with a reagent which contains a reducing agent, a pH buffer and a chelating agent. The reducing agent is to neutralize the excess oxidant. The mixture passes through a heater to speed up this process. The sample is then cooled and passed through a column containing copperized cadmium granules. The buffer and chelating agent were added previously with the reductant because they are necessary in the reduction of NO_3^- to NO_2^- by the cadmium. The sample is next acidified in order to convert NO_2^- to a gaseous nitrogen oxide species which is sensed by the electrode.

The rationale behind evaluating this technique in spite of its complexity was the premise that reduction of the excess oxidant may not need to be quantitative. The level of persulfate ion which interferes with the nitrate electrode is so small that virtually all of it had to be removed in order to make the measurement. It was hoped in the indirect method that any residual persulfate would be consumed by the cadmium column and permit the reduction of NO_3^- to NO_2^- . The presence of the reducing agent was primarily to prolong the active life of the column.

Results with this set-up were unsatisfactory. The reducing agent was so inefficient in removing persulfate that only a partial recovery of NO_3^- as nitrogen oxide was observed. Whereas in the direct NO_3^- determination, selection of reductants was sharply limited to those which were very soluble somewhere in the optimum pH range for NO_3^- measurement (pH 3 to 11) and which would not themselves interfere with the NO_3^- electrode, in the indirect determination the selection is limited to reductants which are very soluble at pH 9 for the NO_3^- reduction, and also at pH 2 for the nitrogen oxide measurement. The reductant in this case must also be not so strong as to reduce NO_2^- ion. The only suitable reductants we found in view of these criteria were phosphite and hypophosphite, and they were only marginally useful in reducing persulfate.

Since the destruction of the oxidant was presenting such a problem, we

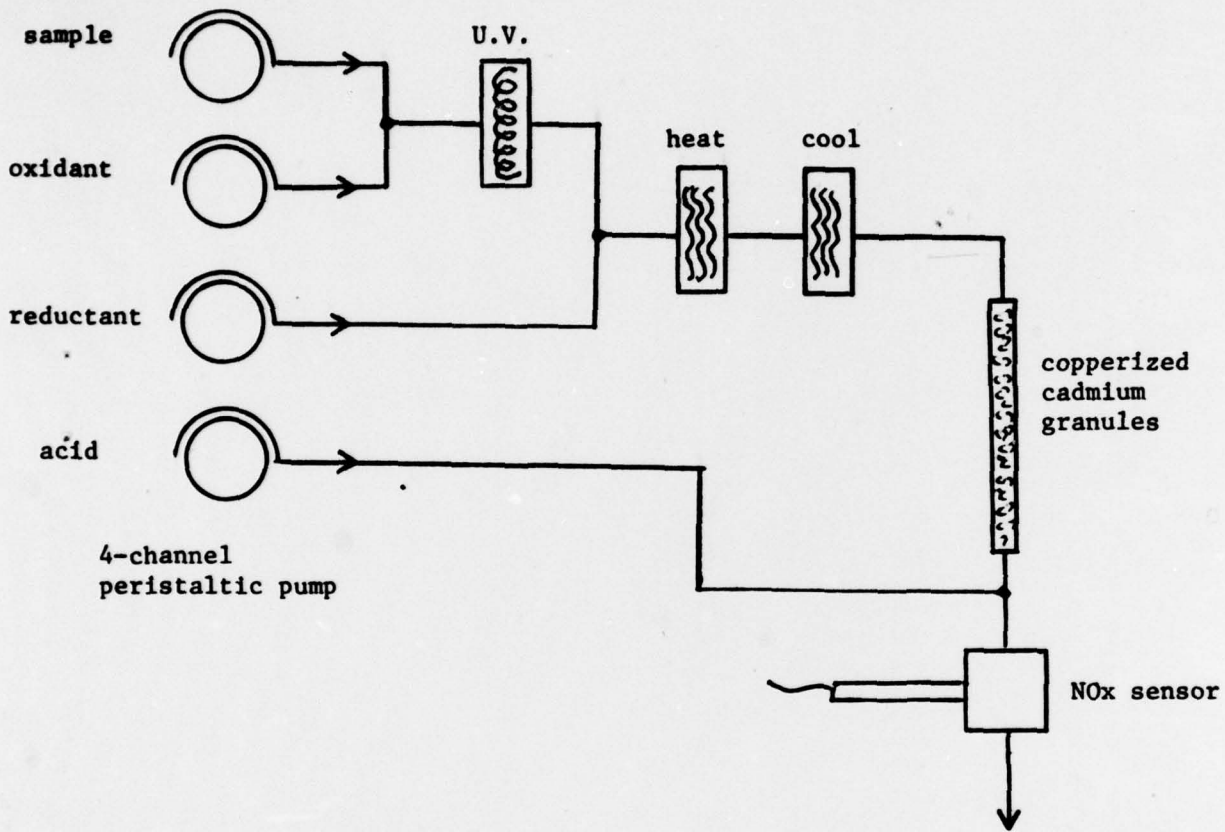

Figure 2.2 ON Experiment Using Cadmium Reduction

looked briefly at two (2) alternate oxidants, dichromate and monopersulfate. Dichromate was unsatisfactory because it failed to oxidize picric acid quantitatively when tested in our TOC apparatus. Monopersulfate (HSO_3^-) was effective as an oxidant of picric acid and seemed to be reduced more readily by hypophosphite. However, its most interesting property was that it proved not as severe an interference to the NO_3^- electrode as peroxydisulfate.

Experiments to determine whether NO_3^- could be determined by a NO_3^- electrode in a monopersulfate background were carried out with the system depicted schematically in Figure 2.3. The reductant was used in this experiment because the monopersulfate interference on NO_3^- is significant, though much less than the persulfate. The primary aim of these experiments was to devise a system which would be capable of measuring NO_3^- , and oxidation reagent compositions were optimized to that end. Less emphasis was placed on optimization for the oxidation process. Determination of the limits within which the NO_3^- measurement could be made would hopefully allow us to integrate the measuring and oxidative system to the best advantage for the determination of the feasibility of the entire concept.

Table 2.2 lists data obtained with the apparatus shown in Figure 2.4. The results were encouraging with respect to detection of NO_3^- over a two-decade concentration range, but no recovery of NO_3^- from picric acid was indicated.

TABLE 2.2

| Sample (ppm as N) | Electrode Reading (mv) |
|----------------------|---------------------------|
| 0 | +125 |
| 1.4 | +121 |
| NaNO_3 4.2 | +116 |
| solns 14 | +111 |
| 42 | +104 |
| 140 | +86 |
| Picric Acid 42 | +124 |

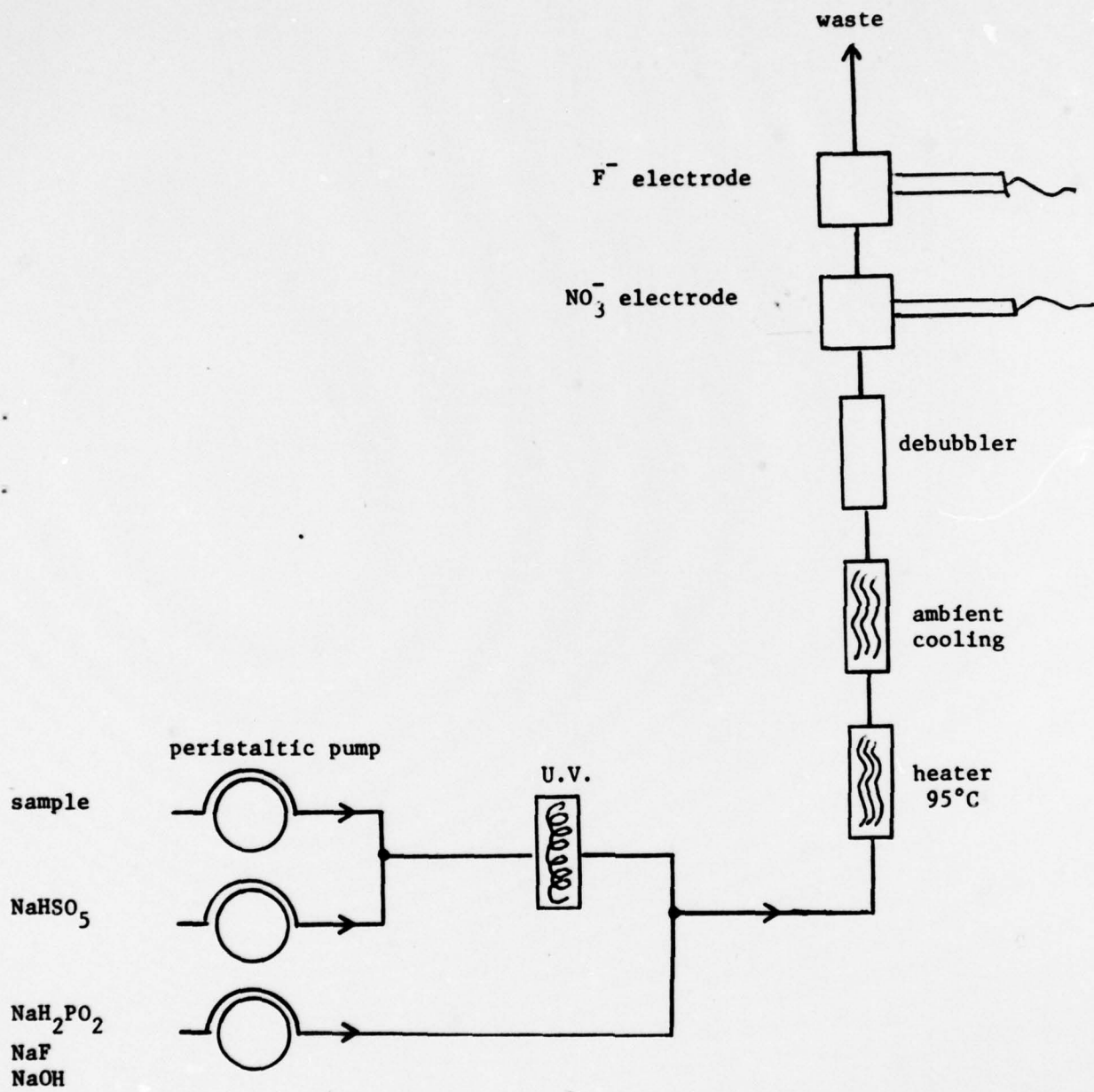

Figure 2.3 Monopersulfate Experiment

We next designed an experiment in which the TOC system was integrated with the ON system. This enabled us to monitor the extent of oxidation by measurement of CO_2 . A flow diagram of the apparatus is shown in Figure 2.4.

The sample was first split by aspirating through a "T" using two (2) equal flow channels of the peristaltic pump. The portion of sample on which the TOC and ON measurements were to be made was then combined with KHSO_5 . The other portion was combined with NaOH and used as the CO_2 stripping reagent. The two (2) portions of sample then passed through the CO_2 stripper. The inorganic carbon-free sample passed through the UV irradiation chamber, and then the CO_2 sensor completing the TOC analysis. The sample was then combined with a reducing agent (hypophosphite ion, H_2PO_2^-) and a "tag ion" (F^-). The reducing agent reacts with the remaining oxidizing agent, which might interfere with the nitrate measurement. Since the reduction is slow, the sample was heated. Prior to measurement, the sample was cooled to room temperature and the gas (oxygen), which is produced in the oxidation step, was removed with a porous Teflon "debubbler". The sample then passed through the NO_3^- electrode and F^- reference electrode. Table 2.3 lists the important data obtained from this system. The results were quite clear and disappointing. TOC was calibrated using MeOH solutions and ON using NaNO_3 . The solution containing 140 ppm of N as NO_3^- showed a 9 millivolt response above background. The solution containing 140 ppm of N as picric acid showed no nitrate response although TOC indicated that the compound had been quantitatively oxidized. 140 ppm N as NaNO_2 also showed a 9 mv response.

This meant that if the organic N was converted to either NO_3^- or NO_2^- it would have been detected. We suspect that some lower form of N, probably N_2 gas, was being formed from the nitro groups on picric acid. These results suggested that this approach to ON analysis was not feasible. It is not known how typical picric acid was of this class of compounds.

Figure 2.4 Combined TOC-ON Experiment

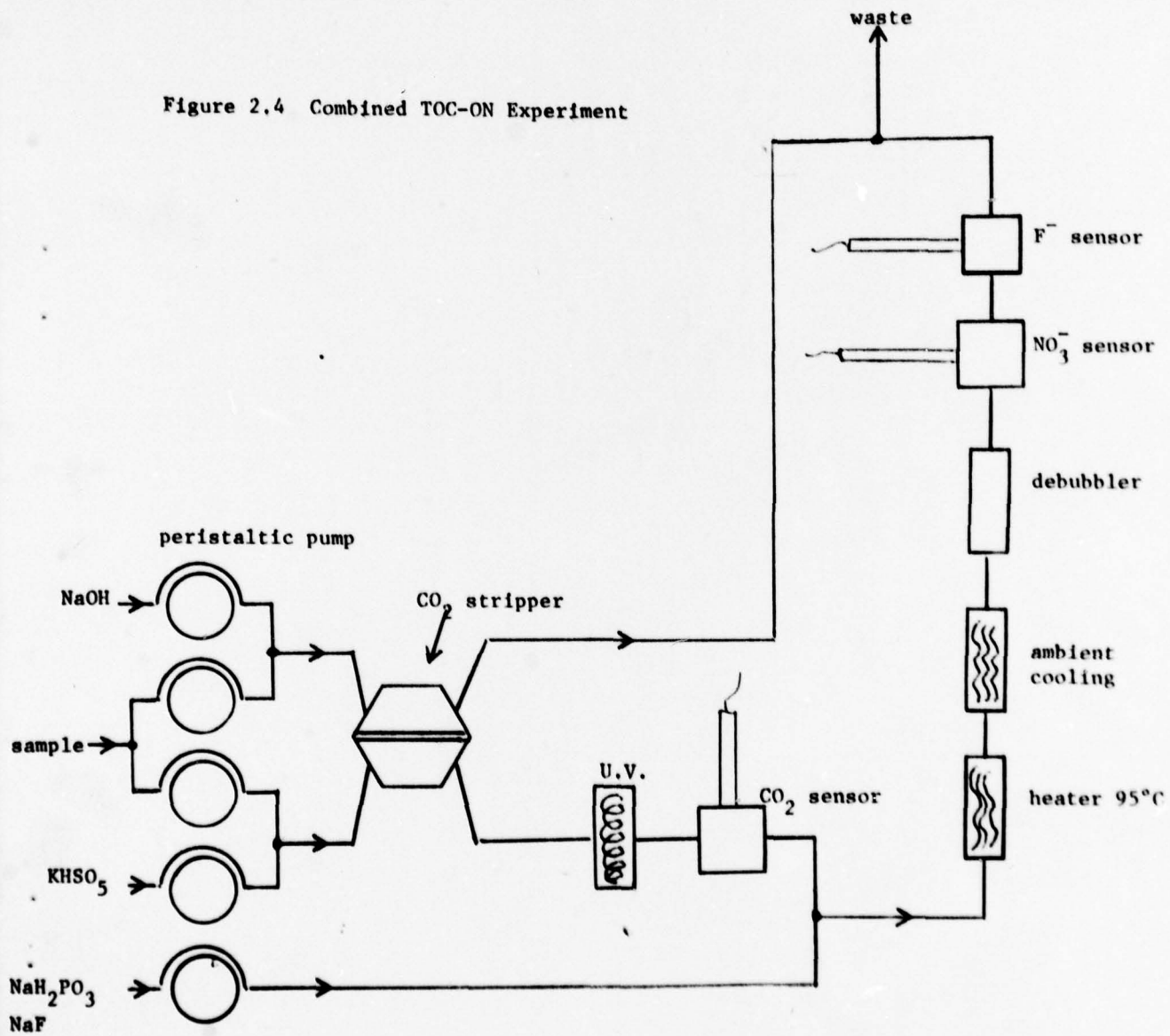

TABLE 2.3

| <u>Sample</u> | <u>TOC (ppm)</u> | <u>NO₃⁻ (mv)</u> |
|--|------------------|--|
| H ₂ O | 6 | +111 |
| 60 ppm C as MeOH | 60 | +110 |
| 120 ppm C as MeOH | 120 | +112 |
| H ₂ O | 5 | +110 |
| 140 ppm N as NaNO ₃ | 6 | +102 |
| 210 ppm C, 140 ppm N as picric acid | 230 | +111 |
| 140 ppm N as NaNO ₂ | 6 | +102 |

It was selected as a model compound because of its structural and behavioral similarities to TNT. Picric acid and TNT are nitro compounds (-NO₂ linkage). Other compounds of interest in this effort are nitric acid ester compounds (-O-NO₂ linkage) such as nitroglycerin. It is possible that the nitric acid ester compounds do not behave in the manner of picric acid when subjected to the UV digestion process. If this is true, UV digestion could be a viable method for monitoring effluents in which the suspected contaminants are of the nitric acid ester variety.

We were unable to determine the feasibility of the UV approach for nitric acid esters. Sensitivity for NO₃⁻ ion in the experimental set-up was poor (Figure 2.4 and Table 2.3), and the complexity and "breadboard" nature of the apparatus permitted insufficient running time for NO₃⁻ determinations.

As a result of these difficulties we began the investigation of an alternate approach to the ON measurement - polarography.

Polarographic ON Determination

Both nitro compounds and nitric acid esters can be determined by polarographic techniques. The applicability of polarography to continuous on-line monitoring of these compounds has been shown by previous investigators (e.g. David, Shaw, Tucker; DAAA21-73-C-0630). The principal

Figure 2.5 Polarographic ON Experiment

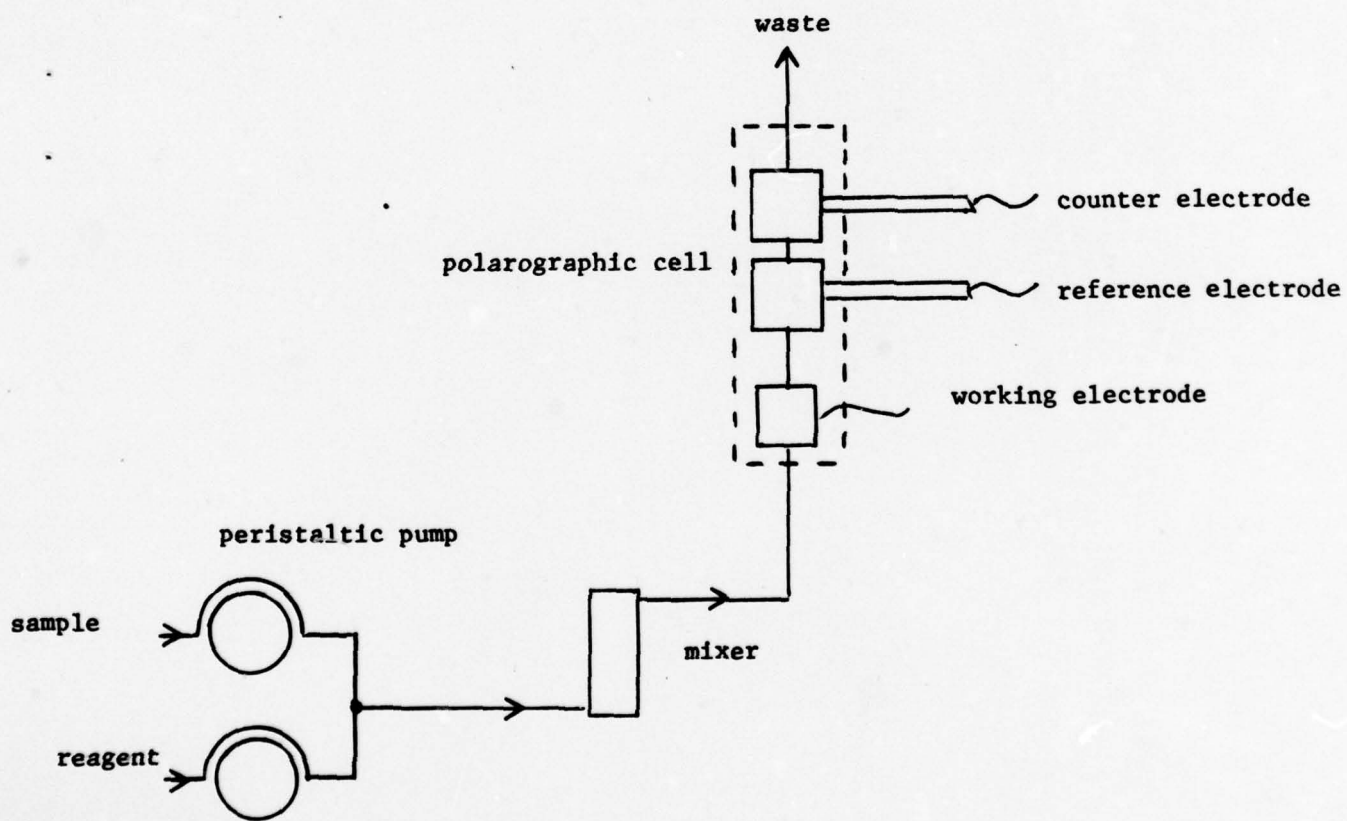

technical problem involved in the use of polarography for the CONTOC monitor was to design an electrochemical cell and reagent system which would be reliable in an industrial situation. Classical polarographic studies revolve largely around the dropping mercury electrode (DME) which is delicate and difficult to design into a flow-through system. The DME has unique features which give rise to its great utility in laboratory polarography. Its surface is constantly renewed so that it is not poisoned. Also, the dropping action prevents the depleted electrolyte layer from extending into the bulk of the solution and therefore allows rapid achievement of steady-state concentration polarization. These features of the DME provided the design goals in the development of the polarographic ON determination.

The first emphasis in the development work was to design and fabricate a flow-through cell with which to obtain initial feasibility data and to evaluate cathode materials. A cell was constructed from two (2) 2 x 2 x 1 inch acrylic plates which were clamped together, pressing a .005 inch piece of metal foil between them. A .094 inch diameter hole was drilled through the plates and foil resulting in a fluid path with a peripherally located cathode. This geometry resulted in a cathode that preserves laminar flow and therefore permits a stable diffusion current by minimizing perturbations in the solution flow at the cathode surface arising from the pulsatile peristaltic pumping action. The solution flows first through the cathode and then through two (2) chambers containing a reference electrode and platinum anode. The cathode potential was controlled by means of a variable potentiostatic circuit and the potential and current were displayed on digital meters.

This device enabled us to determine the critical parameters necessary to design the CONTOC ON system and served as direct precursor to the existing ON cell. The experimental apparatus with which we studied this concept is shown schematically in Figure 2.5. Sample solutions were pumped by a peristaltic pump at a flow rate of 0.5 ml/min. After the pump, the sample mixes with a supporting electrolyte solution which is pumped at 0.1 ml/min. The sample-reagent mixture passes through a mixing assembly where small teflon-coated magnets activated by an AC field agitate the

solution. The sample then flows to the ON cell, passing first through the working electrode (WE, cathode) then past the reference electrode (RE) and then the counter electrode (CE, anode) and then to waste.

The polarographic behavior of various nitro and nitrate ester compounds was studied as a function of cathode material, applied potential and supporting electrolyte composition. It was desired to select conditions under which the compounds of interest would give stable, linear and reproducible signals at the concentration levels expected in the sample waters, and yet not respond to other electroactive species which could be present such as NO_3^- , NO_2^- and S^{2-} .

Platinum, gold and silver were investigated as possible cathode materials. In each case, foil of approximately 0.005" thickness was mounted in the cell as described above. Silver was selected early in the investigation because it provided the lowest and most reproducible residual currents and because its high overpotential for hydrogen ion reduction extended the usable potential range further to the negative.

A supporting electrolyte composition of 1M Na_2EDTA , 2M NaCl , adjusted to pH 11.00 with NaOH was selected. The EDTA serves as a scavenger of trace metal ions which could be reduced and poison the cathode, and also provides buffering at pH 11.00. The alkaline pH prevents evolution of hydrogen on silver to about -1.2V vs. AgCl (3M Cl^-). The purpose of the 2M NaCl is to swamp out ionic strength variations in the sample.

The cathodic operating potential of the ON cell was selected by running current-potential curves on solutions of the compounds of interest as well as solutions of possible interferences. We observed reduction currents for all of the nitro compounds tried within the range of -0.5 to -1.2 V vs. AgCl (.1M Cl^-). Neither NO_3^- nor NO_2^- showed any interference except at the very edge of the hydrogen reduction wave at -1.2 v. S^{2-} showed a negative (anodic) interference at potentials less negative than -0.8 v due to the reaction $2 \text{Ag}^0 + \text{S}^{2-} - 2e^- \rightarrow \text{Ag}_2\text{S}$. Based on these results, we chose an operating potential of -1.100 v vs. AgCl (.1M Cl^-). At this potential all nitro and nitrate ester compounds that we have studied show a response and yet NO_3^- , NO_2^- or S^{2-} do not interfere.

A disadvantage of the polarographic ON measurement is the fact that equal responses are not obtained for equal levels of different nitro compounds. In the CONTOC monitor, the ON system is designed to be calibrated with a solution of picric acid which contains 50 mg/L of nitrogen in the form of nitro groups. The relative sensitivity of the measurement for other nitro compounds is determined by comparison of the output obtained on solutions of known level with the picric acid solution.

During the bench-top evaluation of the ON system, we observed some degree of drift and tailing effects after the same cathode had been on line for several months. Although the exact reason for these effects was not determined, we experimented with the inclusion of a brief period of reverse polarity each day prior to calibration. We found that this electrochemical cleaning cycle improved performance and therefore designed it into the CONTOC automatic calibration cycle. Every 24 hours, the polarity of the cathode is changed from -1.10v to + 1.10v for a period of one minute. The auto-cal cycle is explained in detail in Chapter 4 and in the Operations Manual.

TOC Determination

The TOC analysis is the most complicated of the three CONTOC measurements because it requires that four operations be performed on the sample fluid. The fluid system for TOC is shown schematically in Fig. 2.6. First the inorganic carbon (CO_2 , H_2CO_3 , HCO_3^- , CO_3^{2-}) must be removed. This is accomplished with a membrane stripping device. The "CO₂ stripper" consists of two stainless steel plates in which are milled spiral channels which are mirror images when the plates are placed opposite each other. A thin microporous teflon membrane is sandwiched between the plates resulting in two fluid channels separated only by the membrane.

The sample solution is split equally when it enters the monitor. To one portion is added the acid-oxidant, and to the other NaOH. These mixtures pass through the stripper where the inorganic carbon passes from the

Figure 2.6 TOC Fluid Schematic

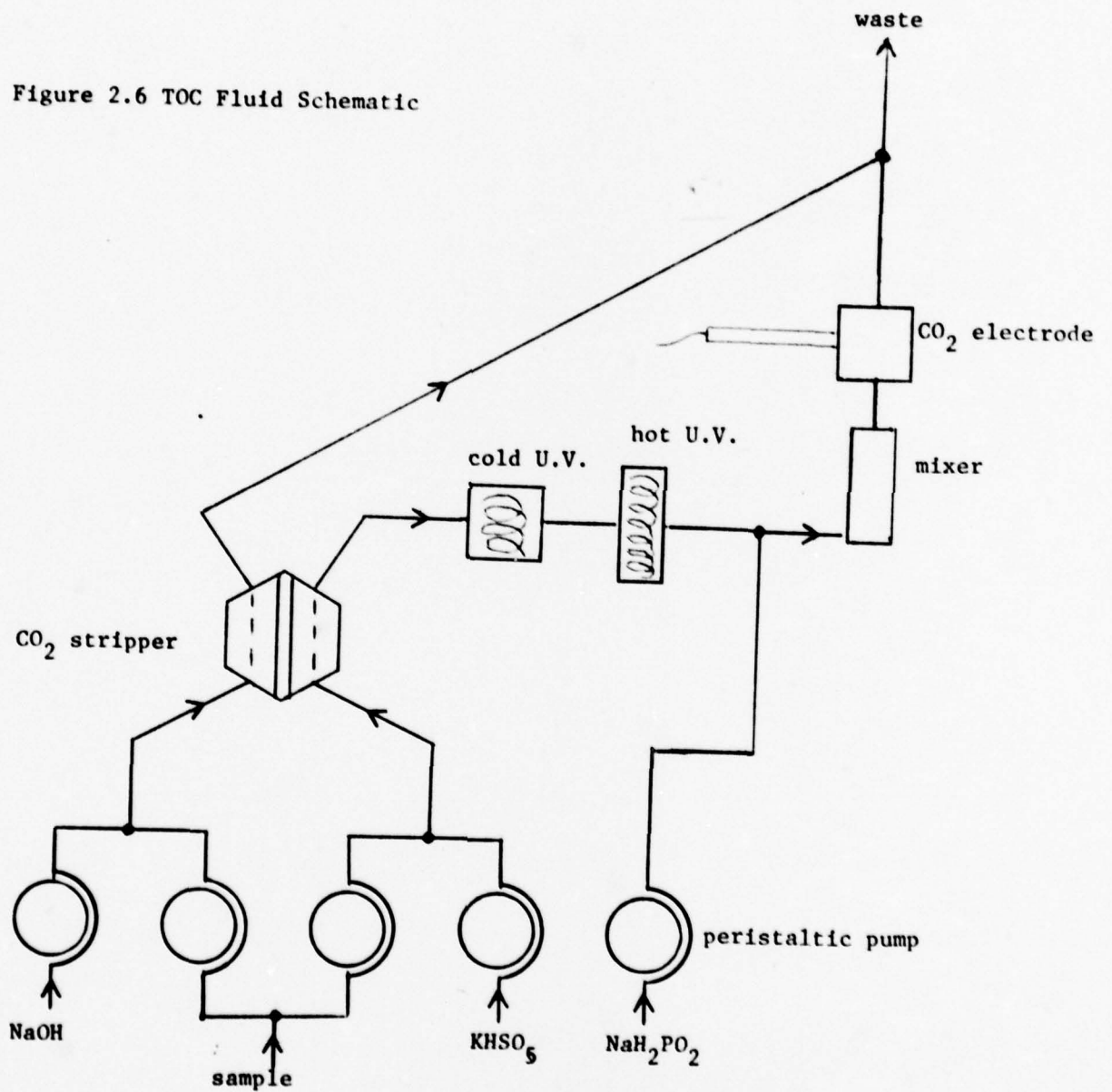

acidic to basic side of the membrane in the form of CO_2 . The alkaline solution then passes to waste.

After the stripper the acidified sample passes through two irradiation components. The first is the "cold UV" chamber. The sample flows through a 2 cm. diameter coil (5 cm. long) of 1 x 2mm quartz tubing. At the center of the coil is a Hg vapor lamp. A fan draws air between the coil and lamp so that the solution is not heated. By this technique volatile organics remain in the aqueous phase where they are oxidized, rather than escape into the oxygen bubbles which are a product of the UV-catalyzed oxidation reaction.

This mixture then passes through the "hot UV" chamber. Here it is exposed to another UV lamp. In this case, however, the 1 x 2mm quartz tubing is coiled tightly about the 6 mm diameter lamp so it is irradiated more intensely and is allowed to be heated by the lamp. This second irradiation is required for the oxidation of refractory organics which are not easily decomposed at ambient temperatures.

The irradiated mixture is next combined with a reducing agent, sodium hypophosphite. Chlorine gas, which may have been formed in the oxidation if the sample contained chloride ions, interferes with the CO_2 electrode and therefore must be eliminated before measurement. The irradiated mixture and reductant pass into a mixing chamber and then to the CO_2 electrode.

CHAPTER 3. SYSTEM DESCRIPTION: MECHANICAL

The CONTOC unit is comprised of three main packages. The fluid input assembly which supplies sample or standard to the peristaltic pumps. The sensor package assembly which contains all components used for chemical sensing, and the operation and read-out electronics. A full description of the electronics will be covered in Chapter 4.

Fluid Input Assembly

The fluid input assembly is mounted on the left inside panel of the CONTOC cabinet and consists of a constant head chamber, sample split block, linear membrane filter, two solenoid valves, and an FMI metering pump. This section of the CONTOC unit controls sample and standard flows. A continuous flow of sample is circulated through the filter where particulates are removed. Sample is drawn off the filter by the FMI metering pump and supplied at a constant rate to the constant head chamber. Within the chamber a reservoir exists with minimum pressure. In the normal "on-line" condition, sample is drawn from the constant head chamber reservoir through solenoid valve #1 (normally open), and into the sample split block where the sample is split into three fluid lines. These three sample fluid lines run directly to the peristaltic pump. From the peristaltic pump, the sample enters the Sensor Package Assembly.

The FMI Metering Pump Model RP is used to supply a constant rate of sample to the constant head chamber. The pump is a positive displacement piston pump which has the capability of varying flow magnitude from 10-100% of normal flow. The cylinder pointer located at the bottom of the pump travels over graduated flow positions (0-10). Zero (0) is the no flow condition, where ten (1) is 100% of flow. The pointer can be manually adjusted over this increment range. Flow direction can also be reversed by moving the pointer to the left of zero. For CONTOC application flow direction will be forward only, and controlled with the pointer to the right of zero. An instruction manual is enclosed in the Appendix.

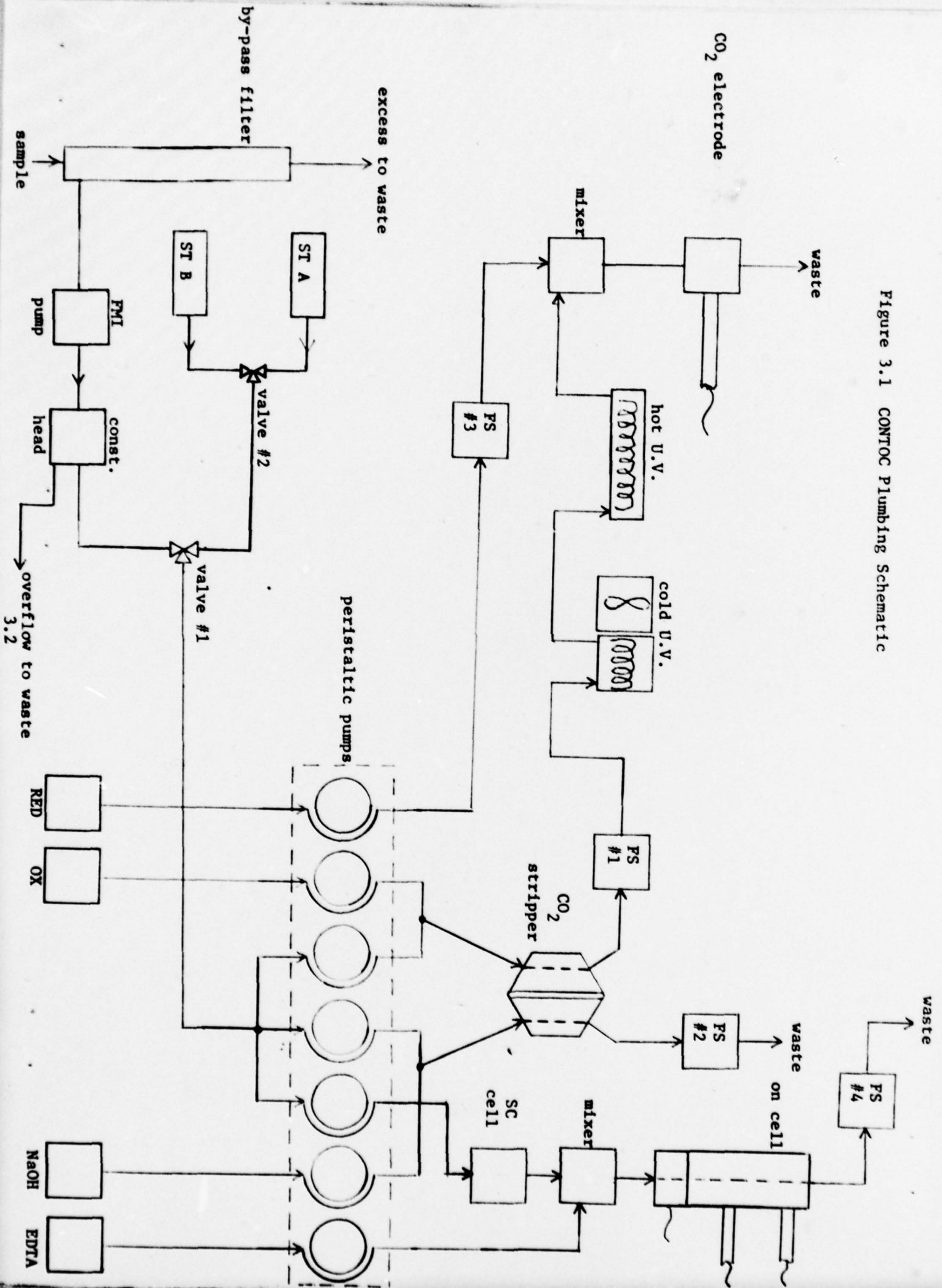

Figure 3.1 CONTOC Plumbing Schematic

3.2

The Orion Linear Membrane Filter consists of a membrane strip and gasket mounted in an enclosure which isolates the process and filtrate sides of the membrane. During operation, process fluid flows into the lower hose barb, over the membrane surface, and exits through the upper hose fitting. Clean sample appears on the filtrate side of the membrane and exits through .031 inch tubing to the monitor.

The Constant Head Chamber maintains a unpressurized reservoir of sample. The sample is drawn off the top of the chamber by the peristaltic pumps and directed to solenoid valve #1.

The two Angar Scientific Corp. Model #250, 3 way solenoid valves are mounted directly to the fluid input assembly plate. In the sample mode both valves are not energized, and sample passes through the "normally open" port and out the "common port" of valve #1 only. When the instrument requires restandardization, solenoid valve #1 is energized allowing either standard A or B to pass through the sample split block, and into the sensor package. The standard solutions are contained at the top of the input assembly plate in two, one liter, polypropylene bottles. Solenoid valve #2 controls which standard will enter the system. When the valve is not energized standard A passes through the normally open port and into the system. When energized, standard B will enter the system.

Peristaltic Pumps

The peristaltic pumps used are the Orion-Sage Model No. 370M. The pump is designed to minimize pulsatile flow, increase tubing life and prevent flow rate changes with time. The pump transports fluids through elastomeric tubing. The tubing selected is 1.5 MM I.D. silicone tubing for the sample channels and .075 MM I.D. Elkay (peroxide cured viton) for the reagent channels. These tubes provide 30 and 12 ml/hr of flow, respectively.

The tubing, teflon coated rollers and pressure plates are lubricated with silicone oil to reduce friction. When the pump is not running, the top cover (pressure plate cover), should be released so the tubing will not remain compressed.

An instruction manual of the 370M peristaltic pump is enclosed in the Appendix.

Sensor Package Assembly

All chemical and sensing operations of the CONTOC Monitor occur in the sensor package. Each component is mounted to the sensor panel which is located on the lower central section of the cabinet. The sensor package assembly contains the following components: specific conductance sensor, hot and cold U.V. chambers, CO₂ stripper, TOC sensor, ON sensor, four thermal flow sensors, two magnetic mixers and a temperature control block.

The sensor package is confined to a 12" x 12" x 6" space. Each component is arranged to minimize sensor response time by using short fluid runs between components. As shown in Fig. 3.1 three sample lines and four reagent lines enter the sensor package. Conductivity is measured first, TOC and ON require reagent addition, along with proper sample-reagent mixing prior to sensing. TOC requires the removal of all inorganic carbon in sample (performed in the stripper) and adequate U.V. exposure, (hot and cold U.V. chambers) prior to sensing. Flow sensors are strategically located to monitor flow rates during operation. After all measurements are taken all fluids are dumped to waste.

Within the sensor package three fluidic circuits exist. Circuit one measures conductivity, organic nitrate and flow (flow sensor 1). Circuit two monitors flow (flow sensor #2) and total organic carbon. Circuit three also monitors flow (flow sensor #3) and is used in the TOC stripper. Flow sensor #4 is positioned on the (R3⁻) reagent line. (See Figure 3.1) As fluid enters circuit 1, it immediately enters the conductivity sensor.

The conductivity sensor is comprised of two 6 mm lengths of thin-walled platinum tubing (.75 mm I.D.), cast by the "lost epoxy" method into a small acrylic block. Each platinum tube has an electrical lead coming off it. The fluid flows through the platinum tubing in series, which

act as electrodes. The fluid stream next continues to a mixing block where reagent, necessary for ON measurement, is added.

The mixing block is simply a fluid path containing small teflon coated magnets. Surrounding the path are two magnetic poles. When the mixer is actuated, the magnets vibrate in an alternating field and thus agitate the sample-reagent mixture.

The mixture now travels to the ON sensor which is a polarographic cell and is comprised of two blocks. The cathode block is a piece of silver encapsulated in epoxy. The reference block is made of acrylic, and houses the Orion 10-00-09 platinum electrode and the Orion 10-00-19 sealed reference electrode. An acrylic clamp holds both electrodes in place. The cathode block is mounted directly to the reference block and sealed using a viton "O" ring. The mixture enters the cathode block and then proceeds through the reference block. The assembly is mounted in an angular fashion to prevent air bubble hang up in the sensor.

The fluid continues to Flow Cell #1 where flow rate is examined. The cell consists of two thin-walled platinum tubes (.075 mm I.D. x 6 Lg.) which are cast utilizing the "lost epoxy" technique, into an acrylic block. The fluid passes into the block and through the tubes in series, where temperature controlled measurements are made, examined electrically and displayed on the edgewise meters located on the rear side wall of the electronics section. The sample stream is now dumped to waste.

In circuit #2 the sample and reagent #2 (acidic) meet and enter the CO₂ stripper which consists of two 316L SS plates with mirror-image spiral channels milled in their opposing surfaces. A CO₂-gas permeable membrane is sandwiched between the plates resulting in two parallel fluid paths separated only by the membrane. One path, Circuit #2, contains the acidic sample. In the opposing path, circuit #3, reagent 4 (R4-basic) is added to the sample. The flow rate of R4 is monitored by flow sensor #3 mounted downstream of the stripper. The CO₂ diffuses out of the acidified solution, crosses the membrane and is trapped by the opposing sample stream, and flows with the opposite channel (circuit 3).

Volatile non-acidic organics do not transfer because their activities are equal on each side of the membrane. Volatile organic acids such as formic and acetic do not transfer to a measurable extent because their vapor pressures are too low at the expected concentrations for significant diffusion to occur in the 30 sec. residence time in the stripper.

The acidified sample stream now passes through flow sensor #2 where the flow is monitored on the edgewise meter at the rear of the electronics section. From here the sample enters the cold U.V. Chamber. The cold U.V. chamber contains a 4 watt pen-ray (SC-1) Hg vapor U.V. lamp, which is surrounded by a 1 mm I.D. x 2 mm O.D. quartz coil. The coil has a .300 in. I.D. and surrounds the .275 inch O.D. lamp. This assembly is housed in a 3.06 inch O.D. aluminum cylinder. Fluid interconnections are made between the quartz coil ends, and barbed polypropylene fittings directly mounted to the aluminum cylinder. The ends of the quartz are coated with silver to prevent U.V. light from attacking the interconnecting tubing (viton). The entire assembly is mounted to the sensor panel. Behind the panel and in line with cold chamber, a Pamotor fan model 8500C is mounted. The fan draws ambient air through the aluminum cylinder, between the lamp and coil, keeping the fluid temperature down. The air is exhausted via a stainless steel duct, to the outside of the cabinet.

The cold U.V. chamber is step one in a two step photochemical oxidation procedure, allowing oxidation of gases which otherwise would be driven out of solution by the heat of the U.V. lamp.

The sample now enters the hot U.V. chamber, step two in the oxidation process. The hot U.V. chamber uses the (11SC-1) pen-ray U.V. lamp, a 1 mm I.D. x 2 mm O.D. quartz coil, an aluminum reflector, and is housed in an aluminum block. The coil again fits snugly around the lamp. The lamp-coil assembly is wrapped with aluminum foil and the foil is sealed with epoxy. The assembly is placed into the aluminum block where the coil ends are seated into premade epoxy plugs. After proper coil alignment, epoxy is applied to seal the coil stem to the plugs and the plugs to the aluminum block. Once the epoxy has cured the chamber is filled with RTV silicone rubber potting compound.

Continuing in circuit #2, reagent #3 passes through flow sensor #4 where reagent flow is monitored. The reagent is then added to the sample stream downstream of the U.V. chambers and directed through a mixing block. Once mixed the sample enters the CO₂ (TOC) sensor. The CO₂ electrode used is the Orion Model 95-01 with flow thru cap. The sample enters the electrode cap and comes in contact with a gas-permeable membrane, which separates an aqueous electrolyte from the sample. Equilibration of the sample CO₂ and electrolyte across the membrane results in an electrode output proportional to the log of CO₂ concentration. The electrode is mounted at an angle to prevent air bubble hang up. From here, the sample is dumped to waste.

Mounted directly to the sensor panel is a heater block assembly. The block contains an Electro-Flex silicone rubber heater, an Elmwood snap-action thermostat and a Fenwal glass probe thermistor. The thermistor senses block temperature and supplies the proper power to the heater pad in order to maintain a desired temperature. The thermostat is used as a back up and is for over temperature protection. If a failure occurs within the system the thermostat will prevent overheating and will shut off power to the heating pad.

Photo 1. Front view of CONTOC Monitor.
The cabinet is 6' tall.

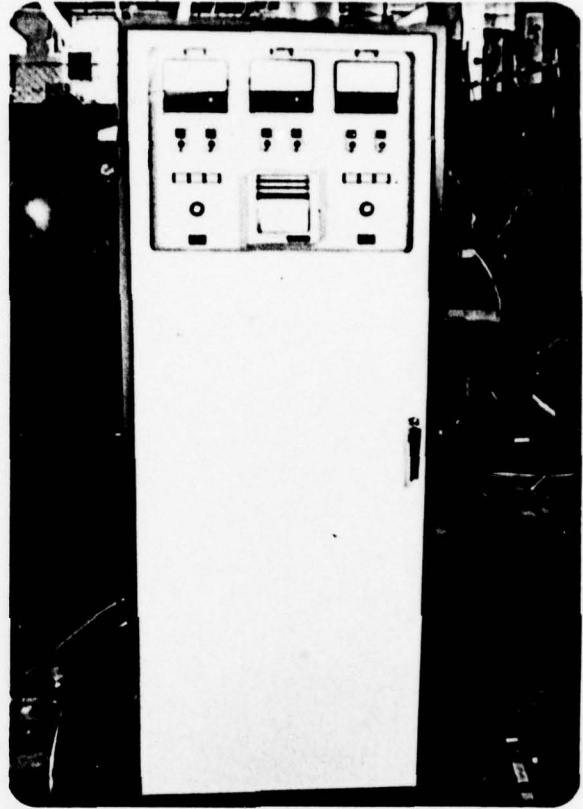
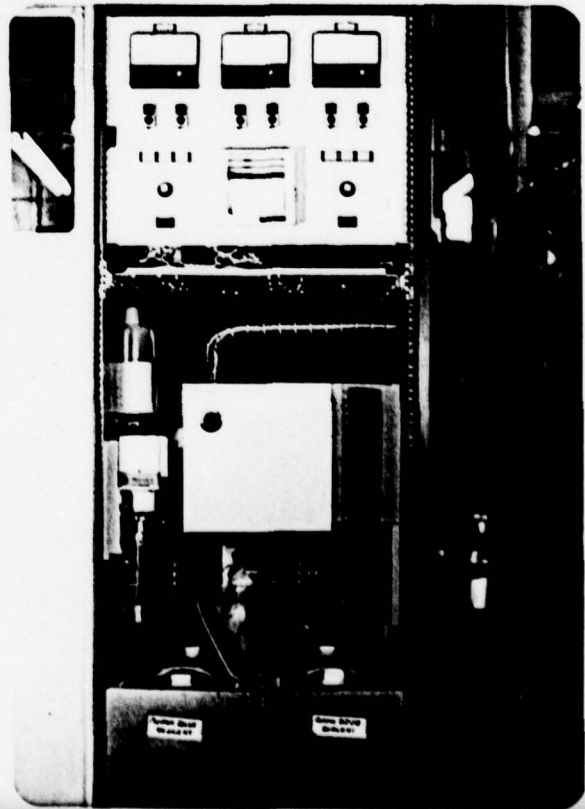

Photo 2. Front view with door open.
Reagents are located in the bottom,
fluid handling apparatus in the center,
and electronics in the top.



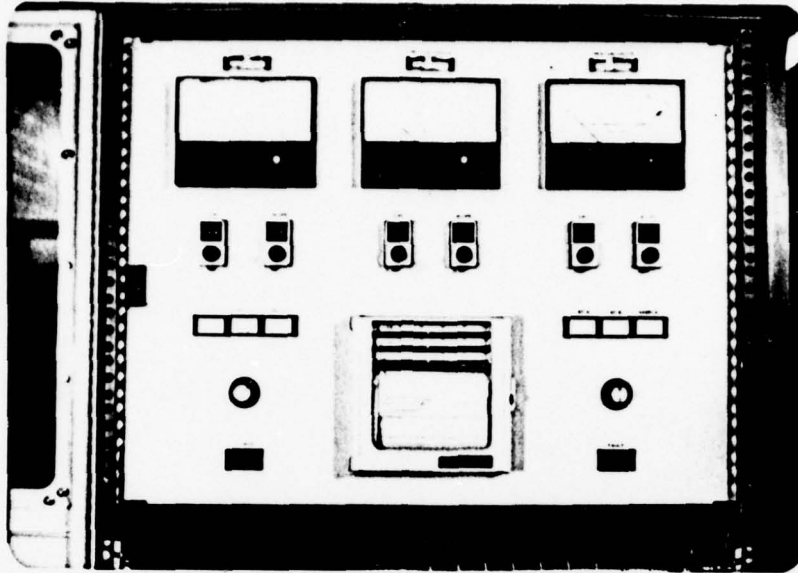

Photo 3. Front Panel. From left to right are the Specific Conductance, Organic Nitrate, and Total Organic Carbon Meters. A 3-pen recorder tracks the three meters.

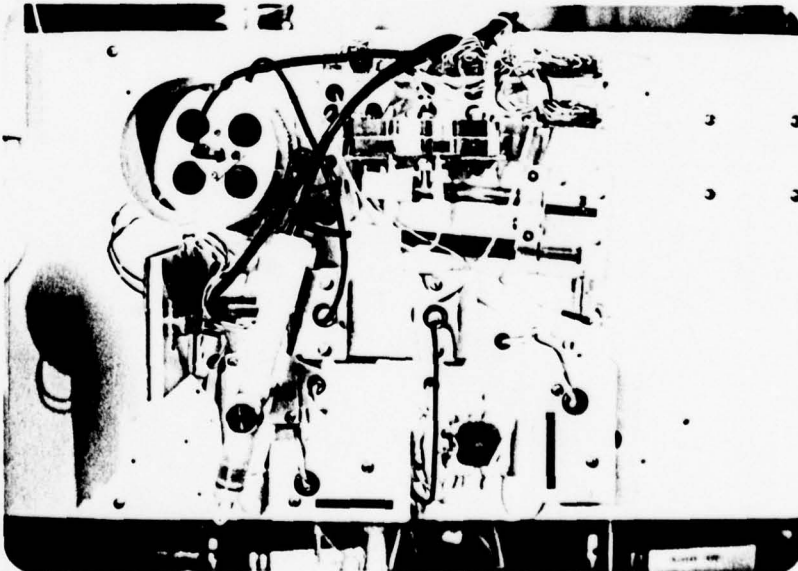

Photo 4. Fluid Handling Section. Removal of the white cover reveals the sensors, UV chambers, CO₂ stripper and flow sensors.

Photo 5. Sample Input Assembly. The FMI pump, Angar solenoid valves, linear membrane filter, constant head chamber and standardizing solution containers are mounted on the left panel.

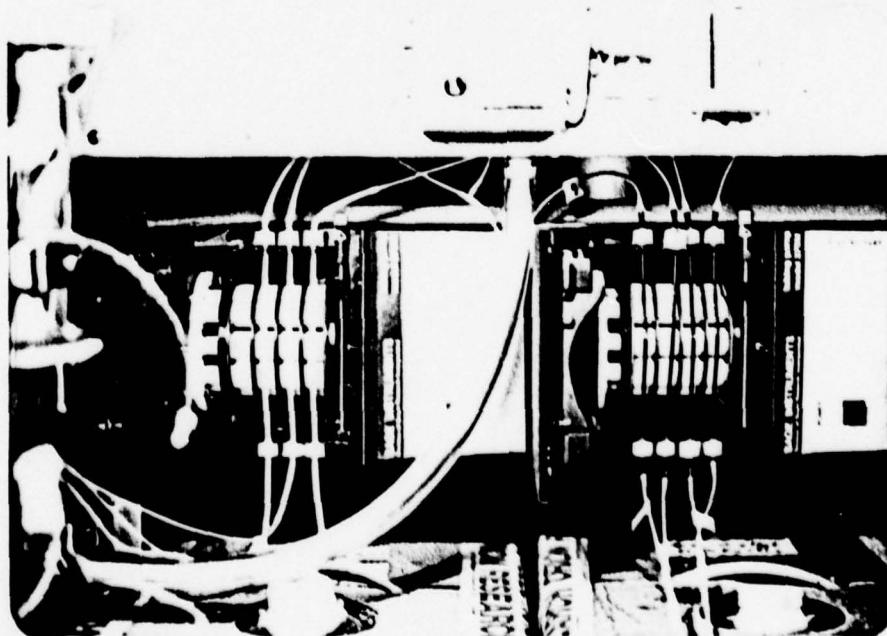
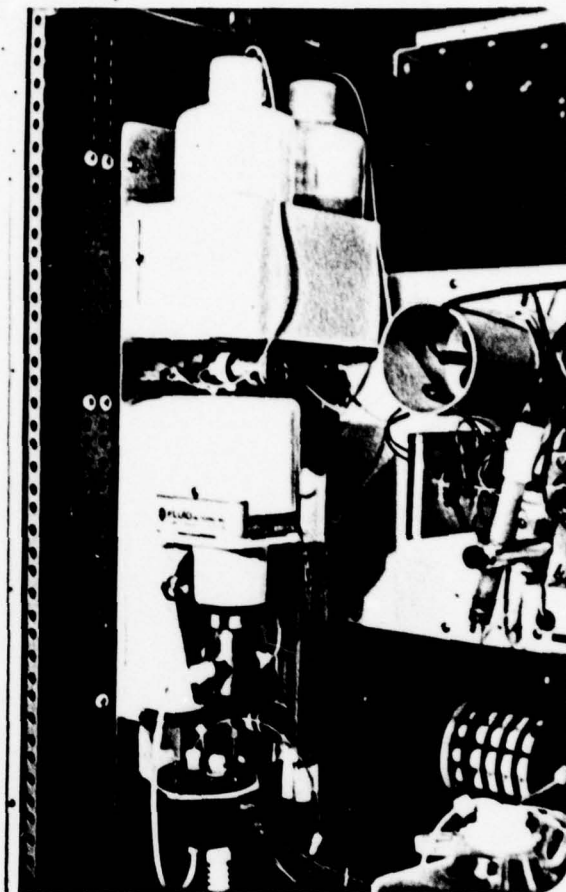

Photo 6. Peristaltic Pumps. The pump on the left meters sample, the one on the right reagents.

Photo 7. Rear View.

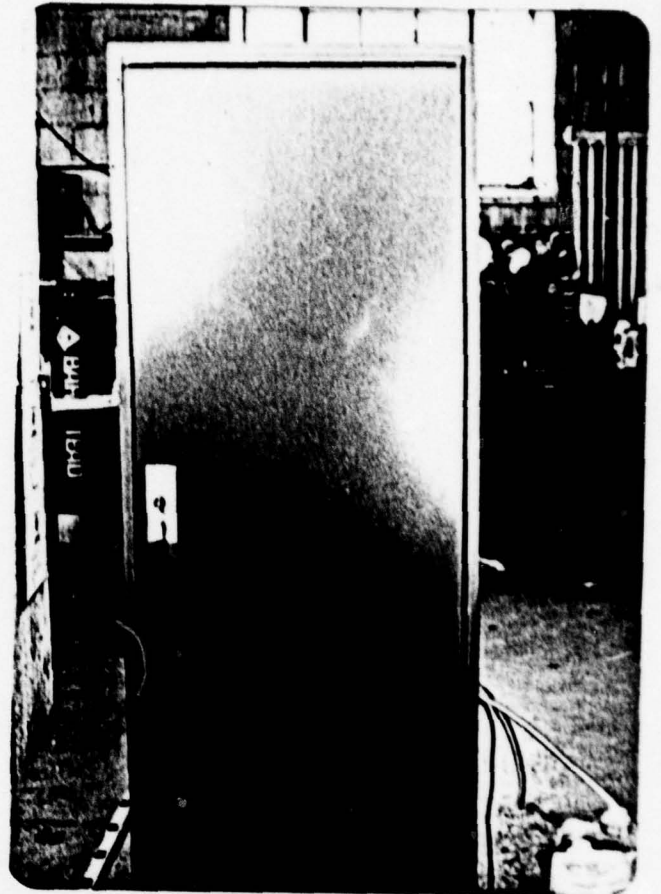
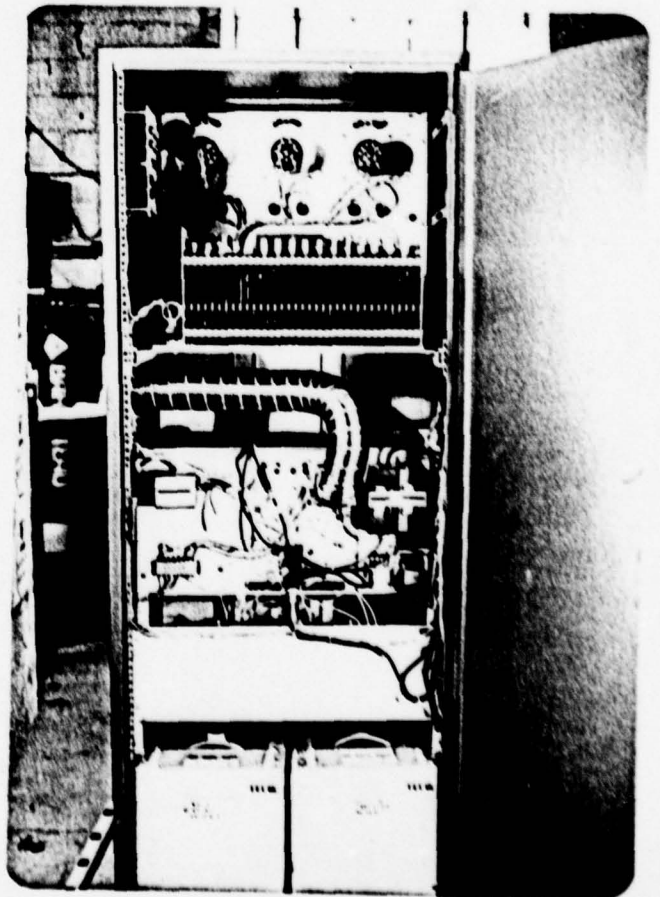

Photo 8. Rear view with door open.



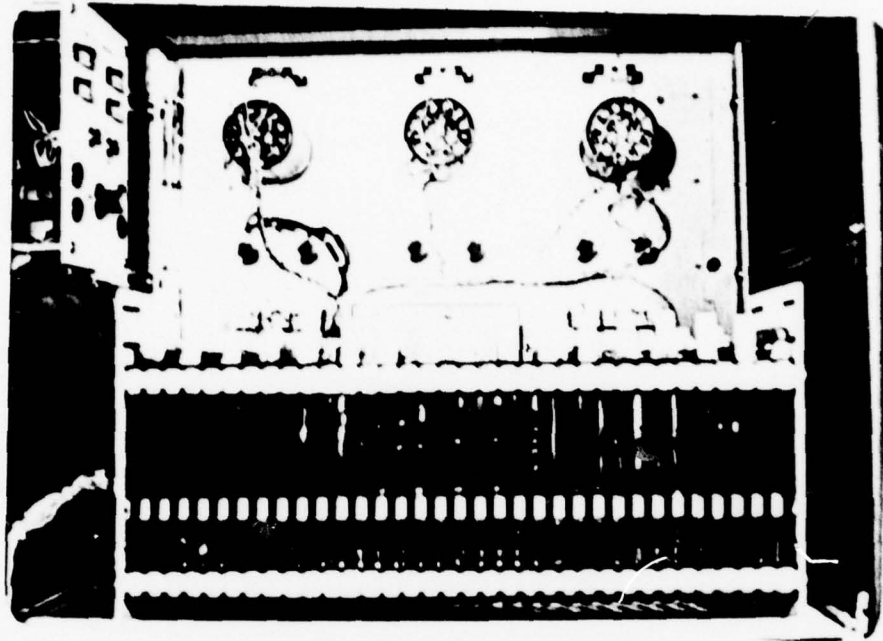

Photo 9. Rear View Top Section. The electronic components are on a sliding shelf for easy access.

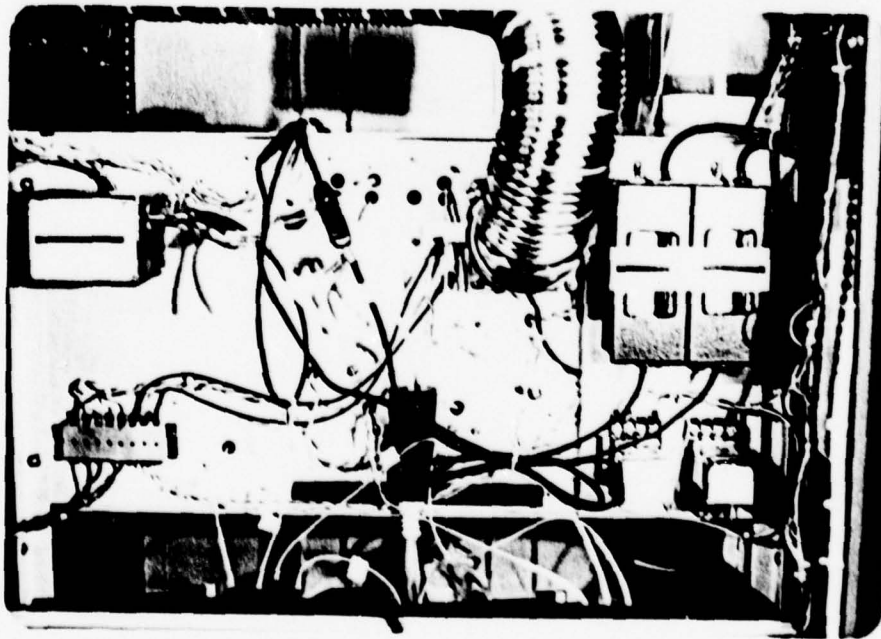

Photo 10. Rear View Center Section. The fluids enter and exit the rear of the panel.

The following 16 photos are close-ups of the CONTOC circuit boards. They can be seen in the rack in Photo 9. They are included for ease of identification and to facilitate trouble-shooting and modification procedures.

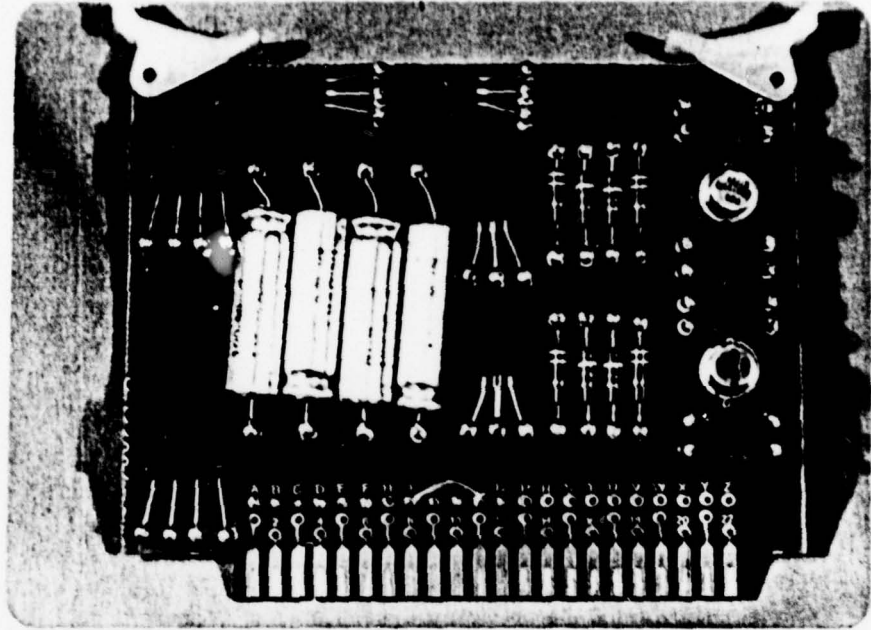

Photo 11. Servo Power Supply Board.

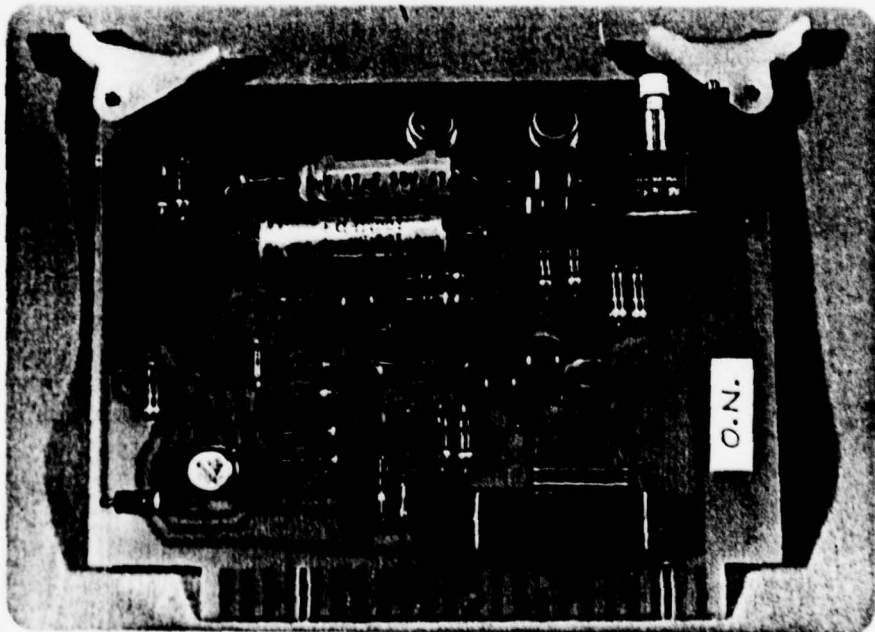

Photo 12. Conductivity Autocal Board.

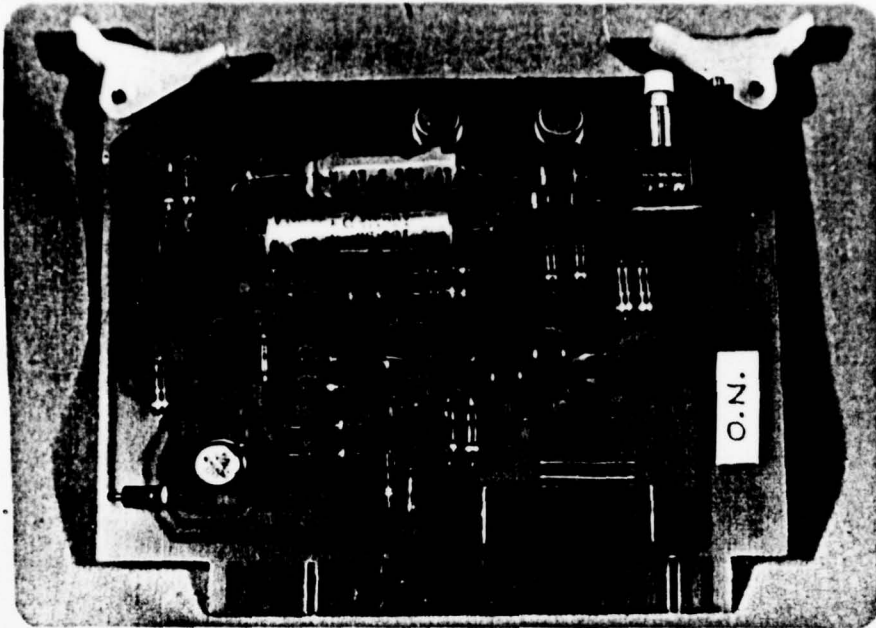

Photo 13. Organic Nitrate Autocal Board.

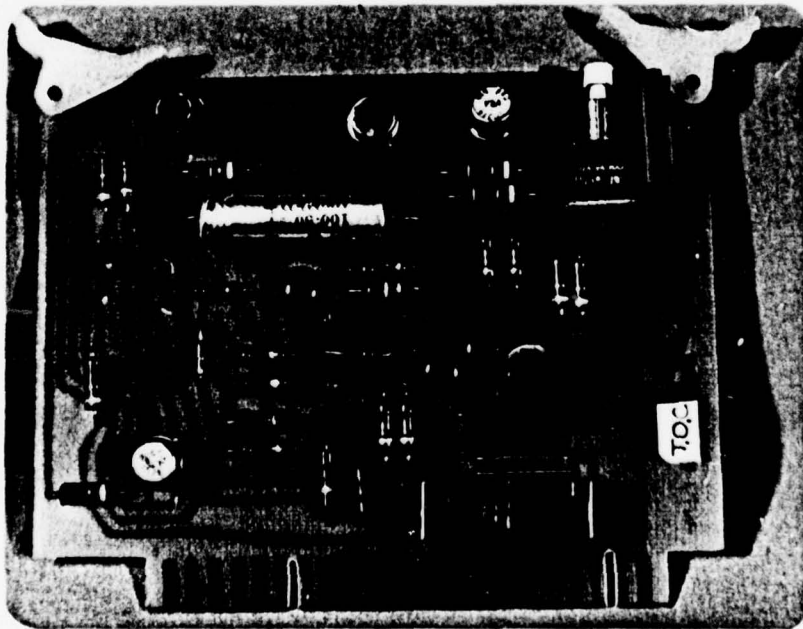

Photo 14. TOC Autocal Board

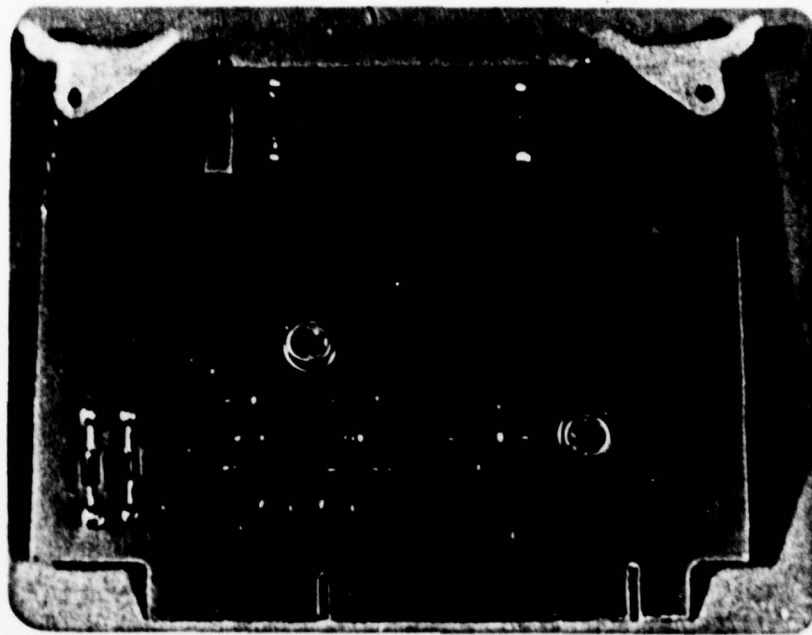

Photo 15. Dual Set Point Control Board

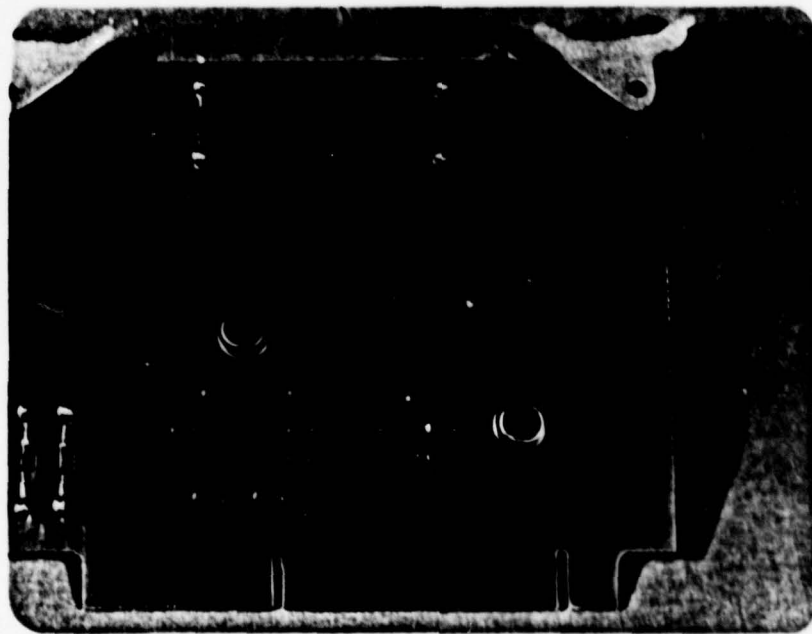

Photo 16. Dual Set Point Control Board

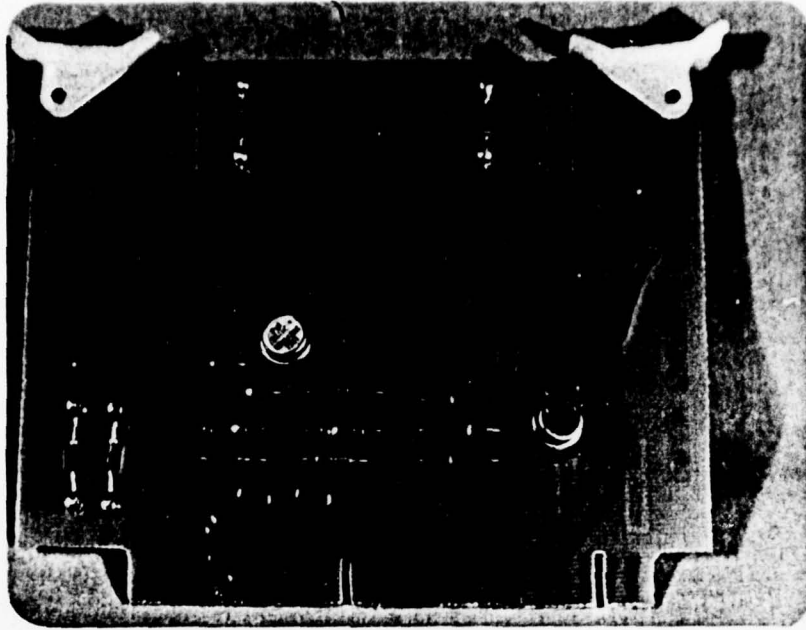

Photo 17. Dual Set Point Control.

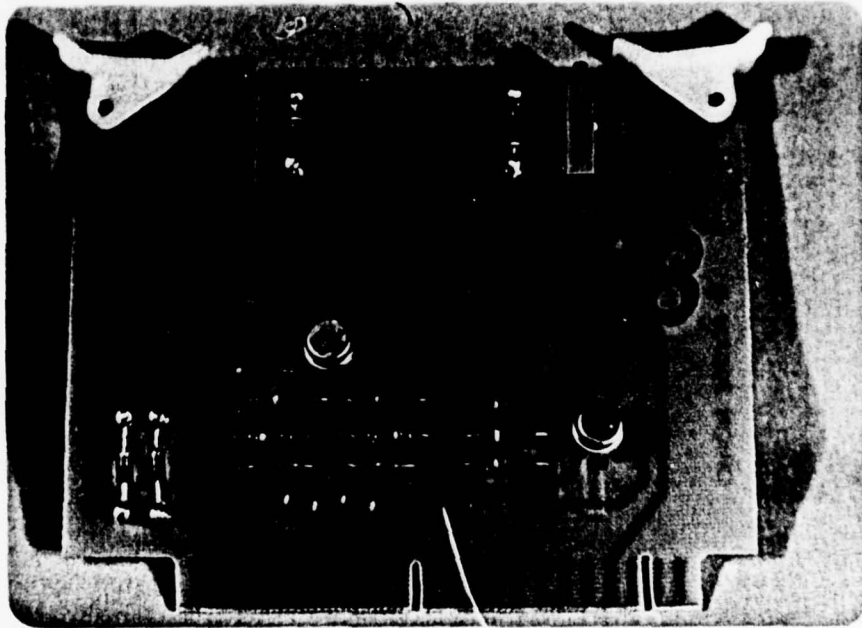

Photo 18. Dual Set Point Control.

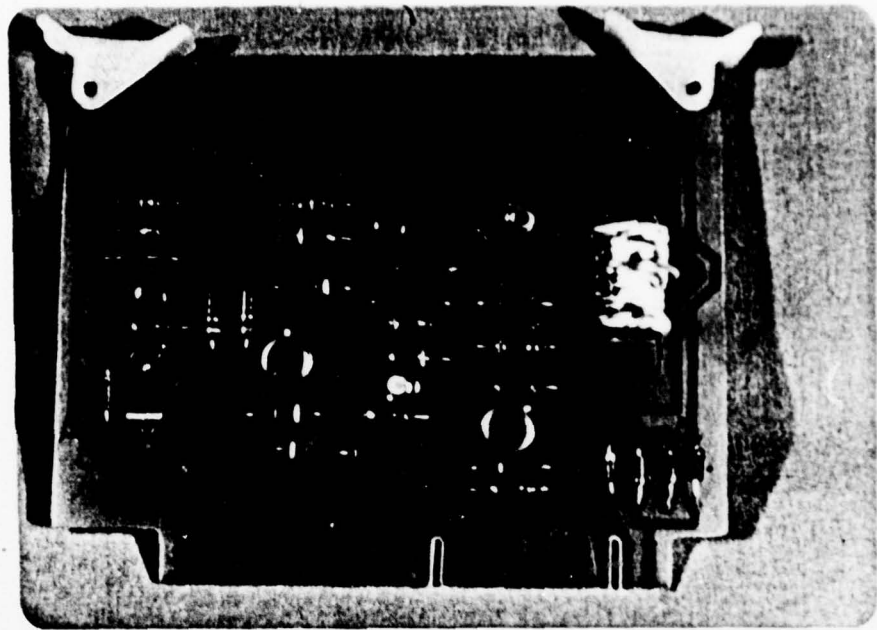

Photo 19. Temperature Control Board.

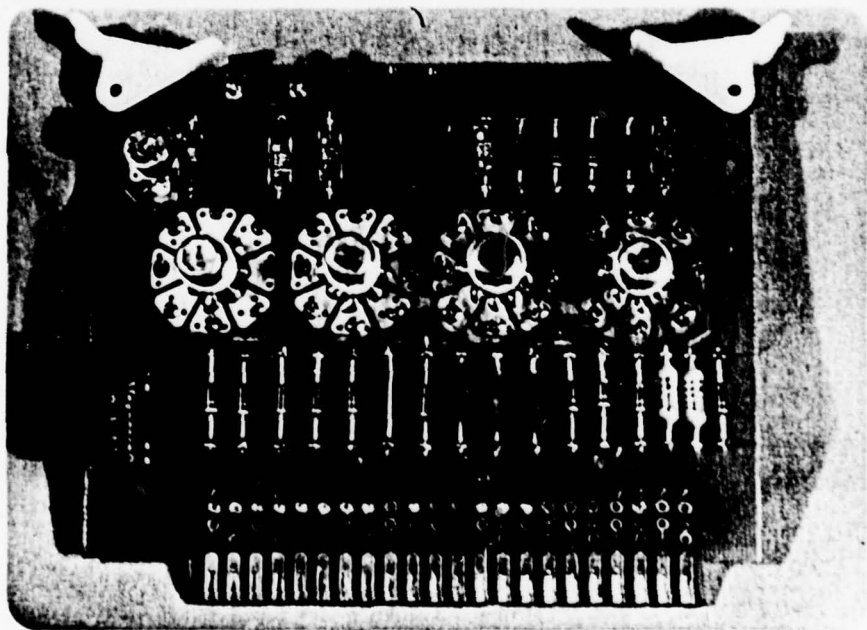

Photo 20. O. N. Amplifier "A".

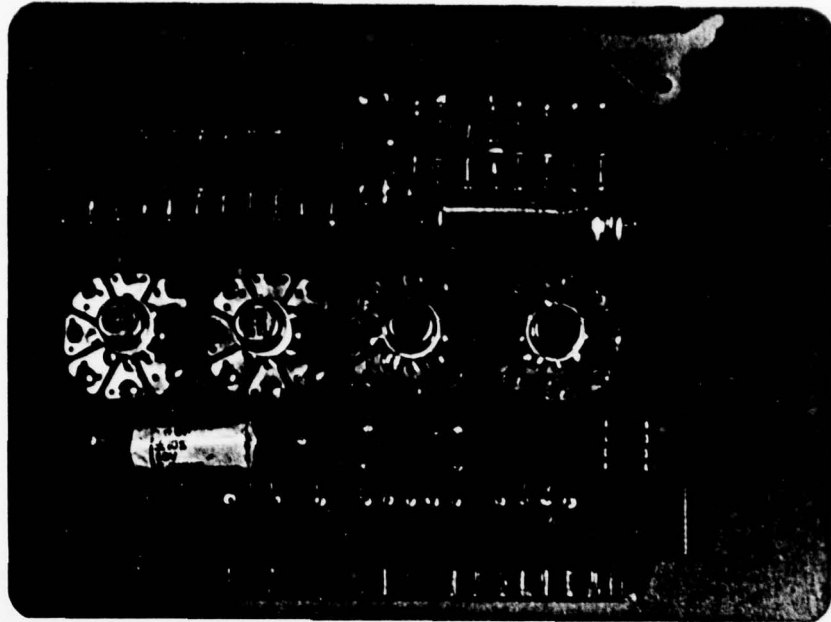

Photo 21. O. N. Amplifier "B".

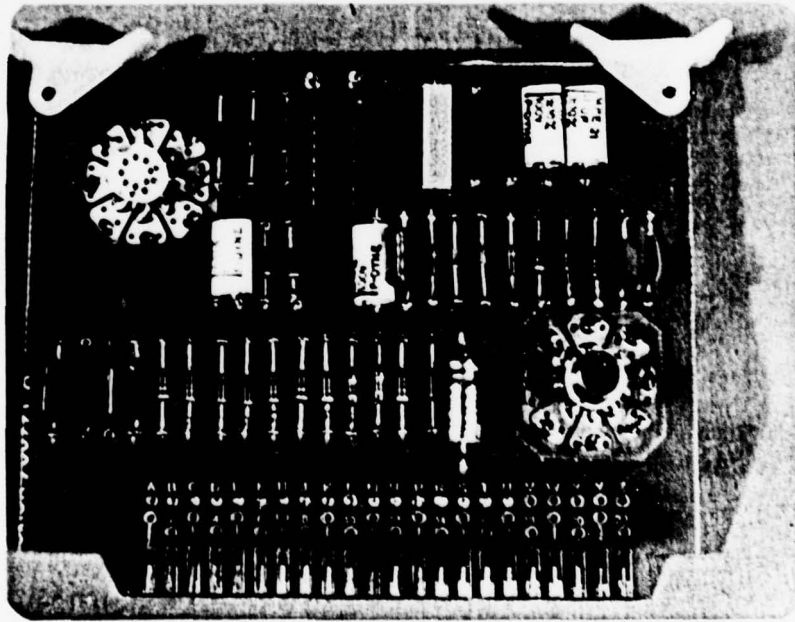

Photo 22. Conductivity Amplifier.

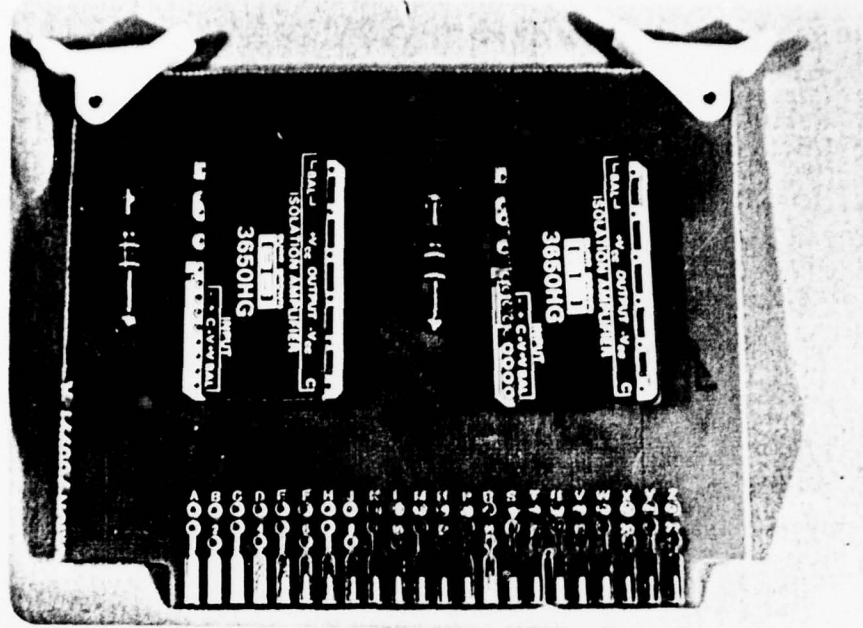

Photo 23. Conductivity and O. N. Isolation Amplifiers.

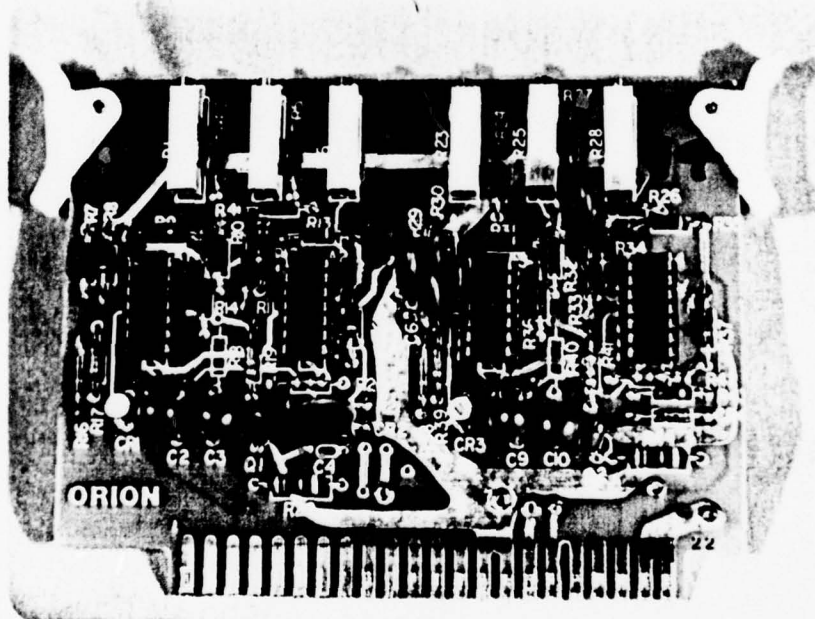

Photo 24. Flow Sensor 1 and 2 Board.

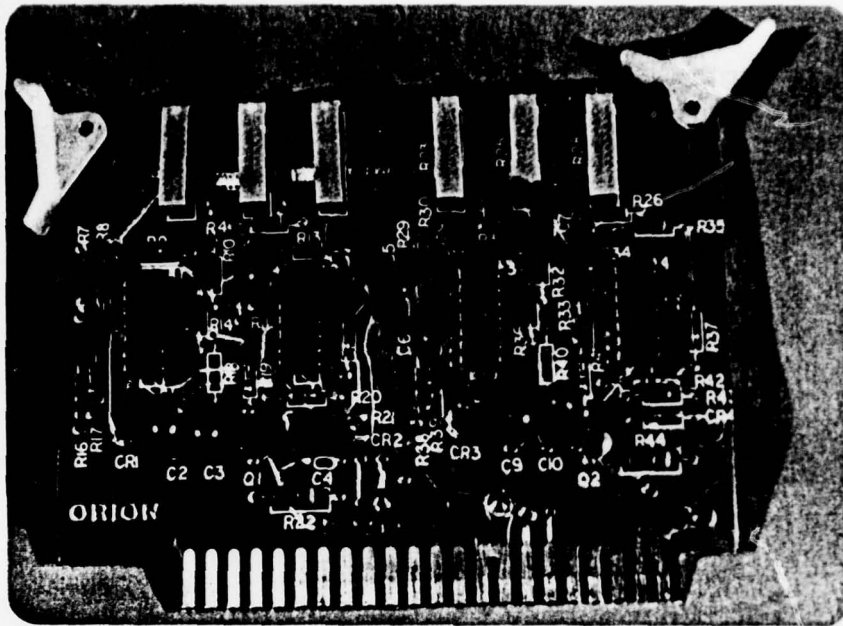

Photo 25. Flow Sensor 3 and 4 Board.

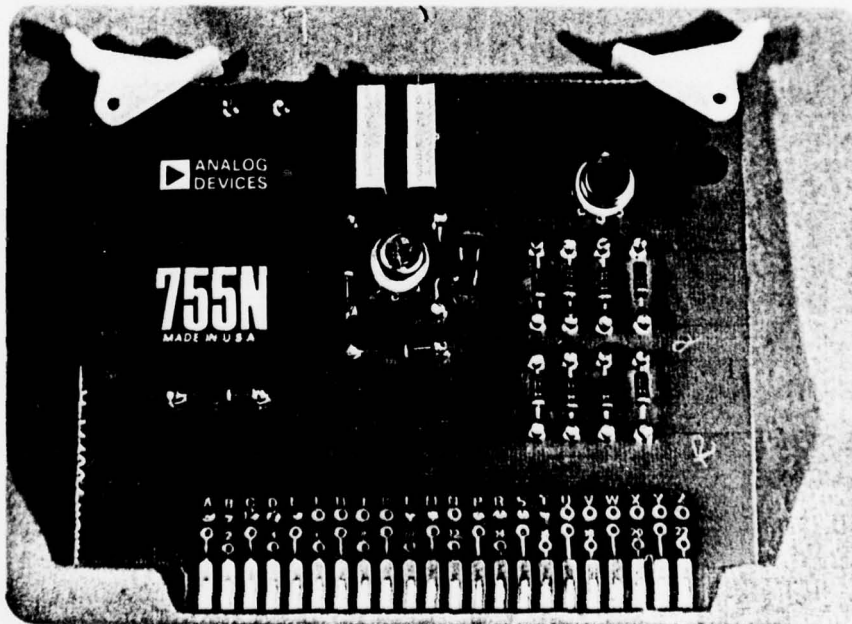

Photo 26. TOC Antilog Board.

CHAPTER 4. SYSTEM DESCRIPTION: ELECTRONICS

The CONTOC system consists of 18 printed circuit boards as follows:

1. Power supplies (2) - Sch. #702057 and 702067.
2. Flow amplifiers (2) - Sch. #801187.
3. Dual set-point control boards (4) - Sch. #702056.
4. T.O.C. pre-amplifier (1) - Sch. #702059.
5. T.O.C. antilog amplifier (1) - Sch. #702062.
6. O.N. amplifier (1) - Sch. #702063.
7. CONDUCTIVITY amplifier (2) - Sch. #702065.
8. Auto-cal amplifiers (3) - Sch. #702066, 702061, 702058.
9. Temperature control board (1) - Sch. #702060.
10. Isolation amplifier (1) - Sch. #702064.

Figure 1 shows a simplified block diagram of the total system. The front panel of the instrument has all the controls and indicators of the electrical and fluidic sections of the system. The appropriate operational mode and control function may be selected using the front panel controls. The valve sequence for pumping either standard solution or sample solution are uniquely determined by the operator in the manual mode, while when in the auto-cal mode the system automatically changes the valves through the sequence, and also calibrates the amplifiers. The auto-cal cycle takes approximately 30 min. to be completed and it takes place once every 24 hrs. The pumps are used to circulate the sampled solution through the sensors, where the three individual parameters (O.N., CONDUCTIVITY and T.O.C.) are measured. The results are directly displayed on the front panel analog meters.

The flow sensors monitor the main four fluid lines, i.e. the three sample solution lines after reagent addition and the fourth reagent line. Any flow discrepancy in the lines will trigger the "FAULT" indicator light located on the front panel. The temperature control monitors and adjusts the temperature inside the sensor box to about 35°C. A complete interconnection diagram of the CONTOC system is shown on schematic diagram #801296. The description of each individual board follows.

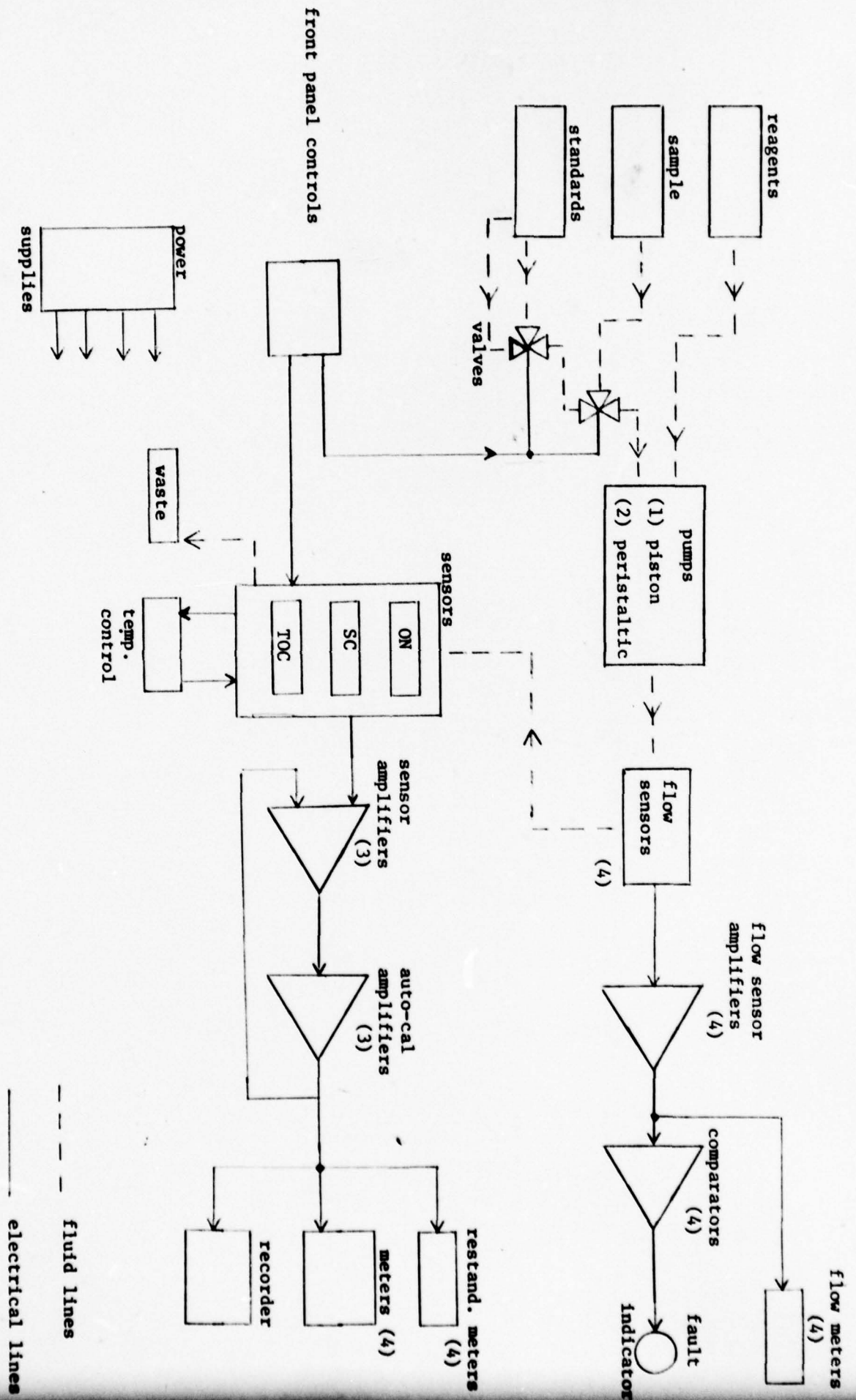

Figure 4.1 Electrical Block Diagram

Dual Set-point Control Board #702056

As mentioned in the general description the main four fluid paths of the system are monitored via the flow sensors for any possible flow faults. The outputs of the flow amplifiers are individually routed to the inputs of each DSPC board. Amplifiers A1 and A2 act as a window comparator, with the high and low set points determined by a fixed voltage level derived from the voltage dividers. The outputs of the comparators drive transistors Q1 and Q2, which are "OR" connected to the "FAULT" light. Four edgewise meters, located on the rear panel, monitor the output voltage level of the flow amplifiers. When a fault occurs the red "FAULT" light will come on. Then by checking the edgewise meters, the respective faulty channel may be determined, since the meter needle will deviate from its proper setting.

Power Supplies #702057 and 702067

There are two power supply boards in the CONTOC systems. The main power supply board #702067 and the Servo Amplifier power supply board #702057. The main power supply board contains four power supplies, of which three are encapsulated modular power supplies designated as A, B and C.

The A supply powers the O.N. amplifier, supply B powers the CONDUCTIVITY amplifier, while supply C powers the T.O.C. amplifier. The ± 24 VDC non-regulated power supply is used to power the T.O.C. auto-cal servo amplifier and timer, the front panel lights and also the solenoid valves. The servo amplifier power supply has two outputs. The $\pm 15V^*$ output biases the O.N. auto-cal servo amplifier while the $\pm 15V^{**}$ biases the conductivity auto-cal servo amplifier. Note that power supplies A, B and C are completely isolated from each other.

In the CONTOC monitor the three parameters are simultaneously measured in the same stream of sample solution. The O.N. and conductivity sensors are current sensitive while the T.O.C. electrode is a voltage sensitive device. If these measurements were referenced to the same ground then currents produced by "ground-loops" in the liquid, would give erroneous

results. This problem is averted if isolated grounds are used. The ± 24 VDC, ± 15 VDC* and ± 15 VDC** power supplies are used to power the T.O.C., O.N. and CONDUCTIVITY servo amplifiers. The reason for using separate power supplies is so noise generated by the motor is not coupled back to the rest of the amplifier to cause any problems.

Auto-cal Boards #702058, 702061 and 702066

There are three auto-cal boards in the CONTOC system, for the O.N, T.O.C. and CONDUCTIVITY amplifiers. The following description is for the O.N. auto-cal circuit, but the same applies for the other two boards, since their design is identical. Amplifier A1 is an inverting amplifier with transistors Q1 and Q2 acting as an output current booster capable of driving motor M1.

When an auto-cal cycle takes place, the following occurs. Referring to schematic 702063, the output of amplifier A5 is calibrated to -2.5 volts when the monitor is in the manual mode using potentiometer R10. When the monitor is in the AUTO mode and the 30 min. auto-cal cycle is triggered, relay K1 of the auto-cal circuit is energized closing switch S1 and thus completing the loop around motor M1. The non-inverting input of A1 is set to -2.5 volts, thus the amplifier will try to balance its input by either sinking or sourcing current at the output, consequently driving motor M1. Motor M1, in turn, drives potentiometer R11 on the O.N. amplifier. When the output of amplifier A5 reaches -2.5 volts, balance occurs and the auto-calibration has been completed. The auto-cal cycle is monitored by potentiometer R13 (sch. #702063) and buffer amplifier A8, which drive the edgewise meter on the front panel.

T.O.C. Amplifier Boards #702059 and 702062

The Total Organic Carbon (T.O.C.) circuitry consists of two boards: the pre-amplifier and the antilog circuit. The pre-amplifier sch. #702059 is a true differential, high input impedance amplifier. The dual FET, Q1, provides the required input buffering, as well as the offset control of the stage. Bipolar transistors Q2 and Q3 form the biasing network of the stage, set at 20 μ A of drain current.

The differential-to-single-ended amplifier A1, is designed with a gain of one, capable of driving the non-inverting amplifier A2, which in turn provides the gain for the stage. Amplifier A3 is a unity gain buffer, used as the auto-cal offset mixer amplifier. When the switch is in the "MAN" mode, then the offset is controlled manually from the front panel CAL potentiometer, while in the AUTO mode the motor ground is connected closing the loop and thus driving the auto-offset potentiometer R18 on schematic #702062.

The output of A3 is fed to the antilog module AD755N, on schematic #702062. Since antilog of 0 is 0.1 and for zero volts input we want the meter to read center scale, amplifier A1 is used to provide the necessary gain for setting the meter to mid-scale. The Buffer amplifier A2 is used to monitor the range of the auto-cal potentiometer (pots R18 and R19 are ganged together). The TOC edgewise meter on the front panel of the monitor should read zero \pm 20% for proper calibration.

Temperature Control Board #702060

The first stage of the temperature control board is amplifier A1, which is connected in the inverting mode. This amplifier is the error amp. and it will sense the changes in the thermistor value due to temperature variations. The reference ramp generator, comprised by unijunction transistor Q1, runs at a constant cycle and slope. Comparator A2, will give a pulse train of 200 ms when the output of A1 and the ramp cross. This train of pulses will determine the frequency of Q3, which in turn will switch the SCR to "ON" or "OFF", thus controlling the amount of heat produced in the heating element. Transistor Q4 monitors the rectified line voltage and it will turn off the heater in case of high voltage.

The thermostat, on the other hand, will disconnect the heater should a fault cause the heating element to overheat. When the temperature drops back to the normal operating level the thermostat automatically resets.

O.N. Amplifier Board #702063

The Organic Nitrate (O.N.) amplifier design is based on the potentiostatic technique, which in turn is used to control the polarographic

method employed for O.N. measurements. The electrode cell comprises of the test electrode, designated as the "working" electrode (WE), and two additional electrodes known as the "reference" (RE) and "counter" (CE) electrodes.

Referring to the schematic diagram amplifier A2 is connected as a voltage follower. The non-inverting input of the amplifier is connected to the control potential, which may be varied from -2.5v to +2.5v using trim-pot R7. The inverting input of the amplifier will follow this potential, and through follower A1 presents it to the reference electrode (RE). Amplifier A3 is used as a current to voltage converter with its inverting input (WE) sitting at virtual ground. Thus the working electrode will be at a known constant potential below the reference electrode. Due to this potential difference a current will flow from RE to WE. Amplifier A3 converts this current to a voltage, inputting it to amplifier A4, which sets the manual and auto-gain. Amplifier A5 is used as a unity gain buffer, its primary function being to null out any overall amplifier offsets when the input is zero. Amplifiers A6, A7, resistor R26 and capacitor C9 are used as a low-pass filter to smooth out the low frequency ripple introduced by the periodic action of the peristaltic pump. Because of this heavy filtering the response of the amplifier is slowed down, but it is within set specifications.

Buffer amplifier A8 and its associated circuitry is used to monitor the movement of the auto-cal pot R11. The O.N. edgewise meter on the front panel of the monitor should read zero \pm 20% for proper calibration.

Timer Z1, transistor Q1, relay K1 and the associated negative potential circuitry are used to reverse the polarity of the RE electrode for one minute, once every 24 hrs., in order to remove any residue build up on the surface of the electrode.

Operation of the circuit is as follows. When the auto-cal motor driven clock-timer switches to the half-hour auto-cal mode, microswitch SW2 (sch. #801296) closes, sending a pulse to the trigger input of the O.N. amplifier. This pulse sets timer Z1, which has a period of 1 sec., so that its output goes low causing transistor Q1 to saturate, energizing

relay K1. The relay contact switches on the negative potential for a period of 1 sec., at the end of which the timer output goes high again, cutting off Q1, de-energizing the relay and returning the non-inverting input of A2 to the positive potential.

Isolation Amplifier Board #702064

The isolation amplifier board uses two optical isolation amplifiers, for the O.N. and conductivity channels respectively. These isolation amplifiers are unity gain buffers and their primary function is to isolate electrically the measuring circuitry from the chart recorder, in order to avoid any ground loops. Recall that all three parameters use their own isolated power supply.

Conductivity Amplifier Board #702065

The design concept of the Conductivity amplifier is derived from basic operational amplifier theory.

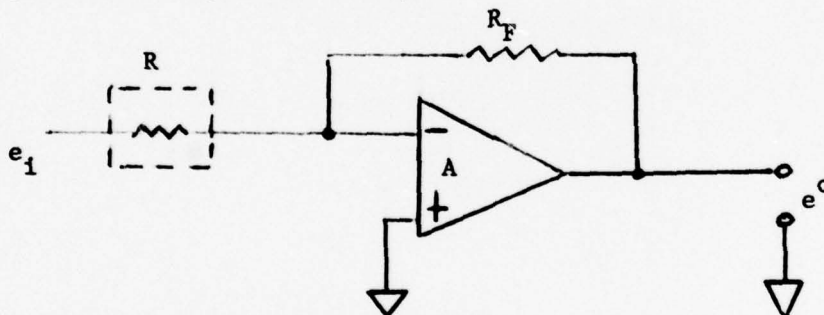

Figure 4.2 shows an operational amplifier connected in the inverting configuration. The gain of the amplifier is $G = \frac{E_o}{E_i} = -\frac{R_F}{R}$. Since resistance (R) and conductance (ρ) are related by $R = 1/\rho$, then the gain equation may be written as $G = -\rho R_F$. If we think of R as being the liquid measured then for a known input voltage and a known R_F , the conductance may be calculated exactly, just by measuring E_o . Conductivity is defined as the conductance per unit length. The units of length (in cm.) are derived from the cell constant K.

Referring to the conductivity schematic diagram, A1 is connected as a Wein bridge oscillator, with AGC and adjustable amplitude control,

running at the frequency of approximately 1 KHZ. Its output sinewave voltage is coupled through capacitors C3//C4 to one of the conductivity cell electrodes. The reason for the signal being AC, is to avoid any electrolysis phenomenon in the measured liquid.

Amplifier A3 is the gain amplifier, for both the manual and auto-gain adjustments. The output of the amplifier is capacitive coupled to A4, which is designed as a precision half-wave rectifier. The amplifier is connected in the inverting-negative polarity selection, and it provides two gains. For one polarity of input voltage CR3 is reverse biased and CR4 is forward biased. During the opposite half cycle CR3 is forward biased and CR4 is reverse biased, dropping the amplifier gain to zero.

Offset calibration adjustment is also provided in the amplifier to set the output of the conductivity circuit to zero when no input is applied. Capacitor C8 is added to the circuit providing a DC output voltage proportional to the peak rectified voltage.

Amplifier A5 is a second order VCVS active filter, with a 40db/decade rolloff frequency, and a 3 db cutoff frequency of about 100 Hz, thus attenuating the fundamental frequency ripple 20db below its nominal value. It is also used as a low impedance driver for the conductivity meter.

Flow Amplifier Board #801187

The flow cell operates in the following manner. T1 measures the temperature of the fluid in the flow cell. The heater supplies heat to the flow cell around the region of T2. T2 is now used to maintain the power to the heater so that the flow cell around T2 is about 1° higher than that at T1.

In operation, the fluid will flow by T1 and then by T2. As the fluid flows by T2 some of the heat is drawn away by the fluid. T2, sensing the temperature change, applies more power to the heater to maintain the constant ΔT at about 1°C. The increase in power is now measured as an indication of fluid flow.

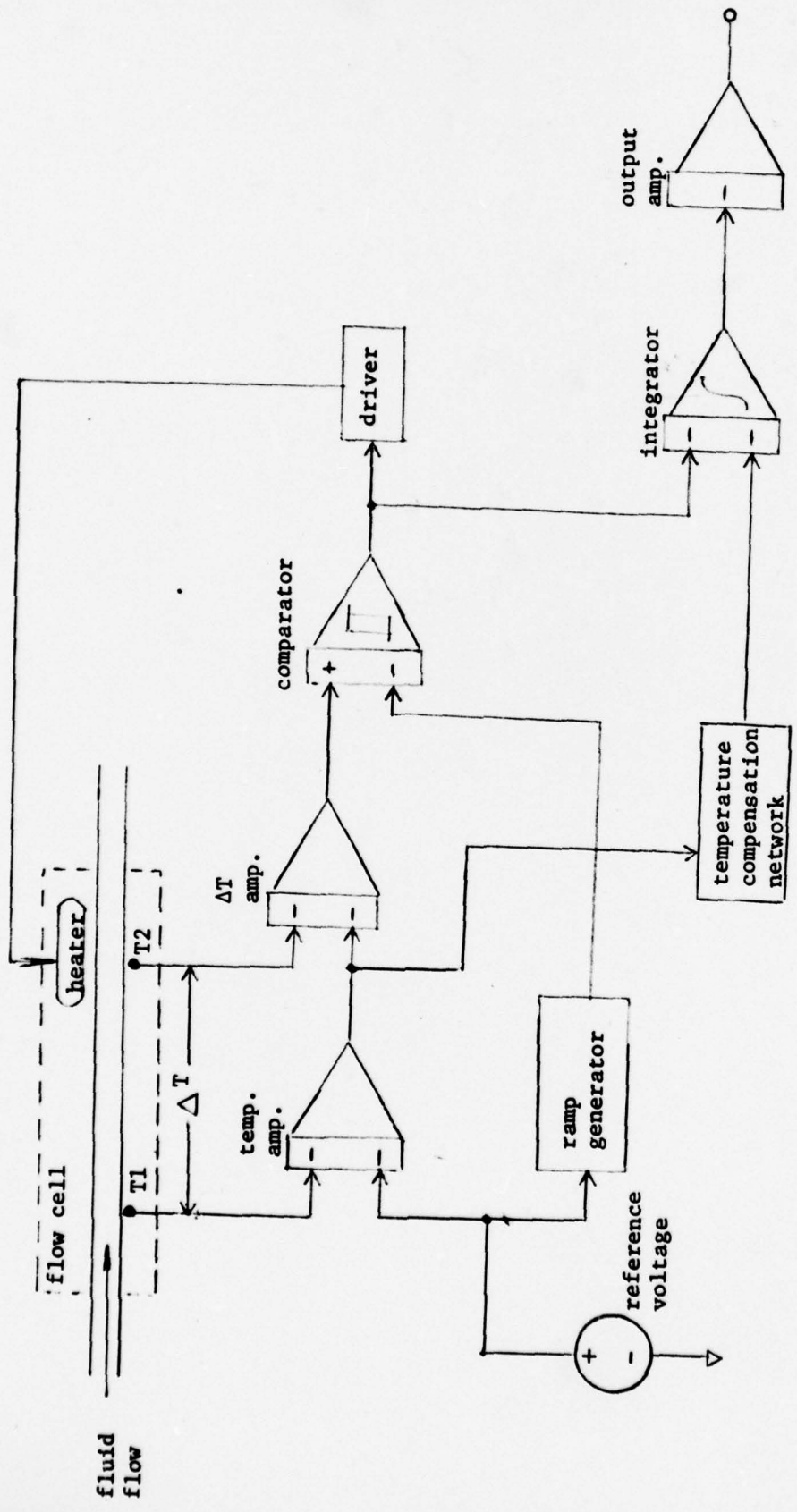

Figure 4.3

The flow cell and the electronics interface in the following manner to provide measurement of flow. The reference voltage ($\approx +.1V$) is applied to both the ramp generator and the temperature amplifier to give them an equal offset. The temperature amplifier now senses and amplifies the reference voltage and T_1 with a gain of -1 . This output is inversely proportional to temperature and is used (as described later) to temperature compensate the flow cell. The output of the temperature amplifier and T_2 are now summed and inverted in the ΔT amplifier. This signal is now applied to the non-inverting input of the comparator. It can be seen at this point that if T_1 and T_2 were equal, then the output of the ΔT amplifier would be equal to the reference voltage. The ramp generator produces a triangle wave signal symmetrical around the reference voltage. This signal is applied to the inverting input of the comparator.

The comparator at this point has the triangle wave on the inverting input and a voltage equal to the reference voltage on the non-inverting input. This produces a square wave with a 50% duty cycle on the output of the comparator and into the driver. The heater now turns on at half power and heats the area around T_2 . As T_2 heats up the ΔT amplifier will reduce the power to the heater to some value less than 50%.

To calibrate the system for zero flow, the gain of the ΔT amplifier is adjusted so that when there is zero flow the output of the comparator has a 50% duty cycle. Because this signal also goes into the integrator and the output amplifier it is easier to adjust the gain of the ΔT amplifier so that the output of the output amplifier is zero. (This is a result of the integration of the 50% duty cycle). Because of the physical configuration of the flow cell and the heater this 50% power makes T_2 about $1^\circ C$ higher than T_1 .

When the flow is brought up to some finite value, heat is drawn away from the T_2 area. This will cause more power to be applied to the heater to bring the difference between T_1 and T_2 back to $1^\circ C$. The power is increased by increasing the duty cycle greater than 50%. This is seen by the integrator and the output amplifier, and the output is increased in proportion to the power.

The gain of the output amplifier is now adjusted to give the output needed for the maximum input flow. Note that, because the output was set to zero with zero flow, the full scale adjustment does not affect the zero adjustment. If the flow meter is to be used with a constant temperature fluid and/or environment it will work as described up to this point. But if fluid temperature and/or environment temperature change, the following procedure must be appended to the above.

The output of the uncompensated flow meter will rise as the fluid temperature and/or environment rises. One will recall that the output of the temperature amplifier was inversely proportional to the temperature of the fluid. As fluid and/or environment temperature rises the temperature amplifier output will go down. If the proper resistor is selected for the temperature compensation network, the effect will be cancelled out in the integrator and the flow meter will be temperature compensated.

CHAPTER 5. PRE-DELIVERY TEST RESULTS

The CONTOC Monitor underwent limited preliminary testing at our facility. The testing consisted of running solutions in which the ON, TOC and conductivity values had been estimated, and observing the response of the instrument.

Of principal interest in this testing was the preliminary establishment of ratios of sensitivity of the ON measurement for various nitro and nitrate ester compounds. The system is calibrated with a solution of picric acid which contains 50 mg/L of nitrogen as nitro groups. Referring to Table 5.1, the ON meter was set to zero with distilled water as the sample. Next standard A (ST. A) was run and the meter set to 50 mg/L. Another picric acid solution, the concentration of which was 29 mg/L N, gave a value of 30.5 indicating good linearity. Next a solution of pharmaceutical nitroglycerine was run. The concentration was 44 mg/L N and the monitor response was 11. Therefore the sensitivity ratio was determined to be 4.0, and the following solutions indicated that this is a reproducible number. Sufficient testing of this nature should provide the information necessary for monitoring of ON in waste streams where the identities of the principal ON containing compounds are known.

The TOC data shows some rather large anomalies. Picric acid, ethylene glycol and 2,4,6-trinitroanisole are the only compounds in the table which show approximately 100% conversion. We did not have time prior to delivery to resolve these discrepancies. We recommend, however, that an oxidizing reagent composed of 1M ammonium peroxydisulfate and 1M sulfuric acid be substituted for the peroxy-monosulfate which was used in these tests. In previous work we have obtained much greater oxidation efficiencies with the former. We used the latter formulation because it has greater long term stability. The peroxydisulfate reagent has the disadvantage that it would have to be replaced weekly. The other reagents in the system need be replaced only once a month. In view of the data shown in Table 5.1, it would appear to be advantageous to use the peroxydisulfate in spite of the inconvenience.

We have encountered no anomalies in the specific conductance (SC) testing and feel that the data is self-explanatory.

Table 5.1

CONTOC Results

| Sample | S. C. | Expected ON (ppm N) | O. N Response | Sensitivity Factor | Expected TOC (ppm C) | TOC Response | % Recovery |
|-----------------------|--------|---------------------|---------------|--------------------|----------------------|--------------|------------|
| H ₂ O | 0 | 0 | 0 | - | 0 | 0 | - |
| STA | 9.6 | 50 | 50 | - | 150 | 150 | - |
| picric acid | 0.2 | 29 | 30.5 | - | 50 | 47.5 | - |
| nitroglycerine | 0.05 | 44 | 11 | 4.0 | UK | 45 | - |
| nitroglycerine | 0.1 | 89 | 22 | 4 | UK | 40 | - |
| nitroglycerine | 0.05 | 44 | 11 | 4.0 | UK | 45 | - |
| nitroglycerine | 0.1 | 89 | 22 | 4 | UK | 40 | - |
| 1-nitroso-2-naphthol | 0.05 | 44 | 11 | 4 | UK | 75 | - |
| 1-nitroso-2-naphthol | .3 | 10 | 7.5 | 1.3 | 86 | 42.5 | 49 |
| 1-nitroso-2-naphthol | .55 | 20 | 14.5 | 1.3 | 172 | 85 | 49 |
| ethylene glycol | 0 | 0 | 0 | - | 50 | 45 | 90 |
| picric acid | .2 | 29 | 30 | - | 50 | 40 | 80 |
| p-nitrophenol | .9 | 50 | 46 | 1.1 | 257 | 45 | 17.5 |
| p-nitrophenol | 1.8 | 100 | 76 | 1.3 | 5.5 | 90 | 17.5 |
| p-nitroaniline | 0 | 10 | 16 | 0.6 | 51.4 | 30 | 58 |
| p-nitroaniline | 0 | 20 | 27 | 0.7 | 102.8 | 70 | 68 |
| p-nitroaniline | 0 | 30 | 41 | 0.7 | 154.2 | 105 | 68 |
| p-nitroaniline | 0 | 50 | 62 | 0.8 | 257 | | |
| nitroglycerine | 0 | 44 | 12 | 0.4 | UK | | |
| p-nitroaniline | 0 | 50 | 64 | 0.8 | 257 | | |
| nitroguanidine | 0 | 50 | 21.5 | 2.3 | 42.9 | 11 | 26 |
| nitroguanidine | 0 | 100 | 40 | 2.5 | 85.7 | 22 | 26 |
| 2,4,6-trinitroanisole | 3.2 | 10 | 11 | 0.9 | 20 | 20 | 100 |
| 2,4,6-trinitroanisole | 6.8 | 20 | 20 | 1.0 | 40 | 43 | 108 |
| 2,4,6-trinitroanisole | offsc. | 50 | 45 | 1.1 | 100 | 85 | 85 |
| 2,4,6-trinitroanisole | offsc. | 100 | 78 | 1.3 | 200 | 200 | 100 |
| CONTOC Bio-Influent | 1.2 | ? | 0 | | ? | 15 | |

CHAPTER 6. CONCLUSION

The best indication of the usefulness of the CONTOC Monitor will be the results obtained during testing at Radford Army Ammunition Plant (RAAP) in Radford, Virginia. We installed the unit there in December 1978 and connected it to a laboratory scale bio-disc waste treatment experiment which was in progress at that time. Initial indications were that the monitor was capable of performing a useful function for such an application. However, there are quite a number of other areas at RAAP where CONTOC's capabilities may be of value. It can be assumed that each of the areas of application have different analytical needs, and as a result the monitor was designed to cover as wide a range of concentrations as possible. Thus, the instrument is not optimized for any one particular use. We will be very happy to consult with the Army and RAAP personnel for the purpose of aiding the implementation of minor modifications which may increase the utility of the monitor for a particular application.

In order to better judge the overall cost-effectiveness of the CONTOC monitor for possible future applications in measurement and control in munitions manufacture, a cost estimate for the reproduction of the unit is included below.

Cost Estimate For CONTOC Reproduction

| | <u>Mechanical</u> | <u>Electrical</u> |
|---------------|-------------------|-------------------|
| Material | 6,000 | 2,200 |
| Labor | | |
| Assy 13.05/hr | 2,088 | 1,044 |
| Test 14.10/hr | <u>564</u> | <u>338</u> |
| | 8,652 | 3,582 |
| Total | \$12,834 | |

CONTOC INSTRUCTION MANUAL

- I. Panel Description
- II. Operating Modes
- III. Initial Check/Start-up Procedure
- IV. Calibration/and Sampling
- V. Maintenance
- VI. Trouble-shooting

Appendix A . Fluidics/Inside Panel Description

Appendix B Reagents and Standards Preps.

1. Panel Description

All CONTOC panel features are visible when the front panel door is closed. Open the door to gain access to the instrument panel, the reagent compartment and the covered sensor package.

1.1 Power Switch - The green button at lower left lights up when pressed.

1.2 Mode Selector Switch - The three position switch directly above the power switch on the left hand side of the panel turns to select ST. BY, MANUAL, or AUTO operation modes. The mode indicator buttons light up.

1.3 Fault Light - The red button at lower right lights up to indicate either a flow fault or a U.V. lamp failure.

1.4 Sample Selector Switch - The three position switch directly above the fault light on the right hand side of the panel operates identically to the mode selector switch to sample STA, STB, or SAMPLE.

1.5 Chessell Strip Chart Recorder, Model 301 - The recorder mounted at lower center operates 3 pens simultaneously: green/black for conductivity, red for organic nitrate, and blue for total organic carbon. See separate instruction manual.

1.6 Analog Meters - The three analog meters for specific conductance, organic nitrate, and total organic carbon are controlled by means of the CAL and SCOPE dials located directly beneath each meter. The meters themselves have an over-range set dial (lower right knob) which moves a red needle across the scale. A red indicator light signals when the black sensing needle passes the red.

1.7 Restandardize Meters - The small meters located directly above each analog meter, operate at $\pm 100\%$ variance from initial calibration.

2. Operating Modes

2.1 ST. BY Mode: In the standby mode all systems are activated except for the peristaltic pumps. No liquid will flow through the system in this mode, enabling the operator to change or replace reagents, standards, tubing, etc., when necessary. The red fault light will signal immediately upon switching to the St. By mode and will shut off within 2 minutes of returning to either the MANUAL or AUTO modes.

2.2 MANUAL Mode: In the manual mode the peristaltic pumps are activated and sample and reagents will begin flowing through the system. Should the fault light fail to shut off within a few minutes, a flow fault or a U.V. lamp failure is indicated. (See Trouble-shooting, Sec. 6, for instructions to correct fault conditions.) Sampling is controlled by the operator at all times; no autocal cycle will trip in while the monitor is in MANUAL mode. The sample selector switch controls 2 solenoid valves, located on the left inside panel of the monitor, which are normally off when the switch is in SAMPLE. By switching to STA Solenoid Valve 1 is activated, to STB solenoid valves 1 and 2 are activated, channelling the correct standard solutions into the system while sample is cut off at the lower valve and vented from the constant head chamber. See CONTOC FLUID SCHEMATIC. The monitor should not be allowed to sample in either STA or STB position for long periods of time.

2.3 AUTO Mode: The auto mode features an autocal cycle which will clean the polarographic ON cell, and sample and recalibrate to standard A every 24 hours. The autocal cycle lasts for 1/2 hour and should not be interrupted. When operating in the AUTO mode keep the sample selector switch on SAMPLE. At the beginning of the cycle the timer activates a one minute reverse-polarity cycle to the ON cell and simultaneously trips on solenoid valve 1 which begins the sampling of standard A. The auto-cal period is the only time the STA light will be on when the selection switch is on sample. At the end of the half hour auto cal cycle the timer simultaneously activates the restandardizing servomotors and inactivates the solenoid valves, returning the flow to sample.

3. Initial Check and Start-up Procedure

Before starting the CONTOC Monitor an initial check of the working parts is advised.

3.1 Unscrew protective cover and check components of the sensor package.

3.1.1 Check all tubing connections.

3.1.2 Check all component mounts and assemblies for secure fitting and seals.

3.1.3 Check standard and reagent volumes.

3.1.4 Do the same for the left side panel.

3.2 On Line Sampling

3.2.1 Connect sample fluid source to the lower black fitting on the outside of the left side panel, which feeds sample into the linear membrane filter. Likewise attach a suitable outlet hose to the top of the filter at the top black fitting on the outside left panel.

3.2.2 Set the FMI pump to position 4 to begin; you may wish to change the pump setting later as you gain experience with sample pressures and viscosities.

3.2.3 Place the peristaltic pump tubing into the appropriate slots, lubricate pressure plates, rollers and tubing, and close the pump lids.

3.2.4 Replace protective cover. You may wish to leave the cover off during the initial start-up.

3.2.5 Turn power on and sample distilled or deionized water.

3.3 Discrete Sampling

3.3.1 The monitor has been shipped to you in condition for on-line operation. If you wish to test discrete off-line samples, this can be done by simply disconnecting a few leads to the FMI pump.

3.3.2 With the POWER switch off, unplug the monitor from the outside power source.

3.3.3 The FMI pump is connected to a terminal block located at the rear of the left side panel. It is accessible from the rear of the monitor (it will now be on the right hand side.) A white cable connects to positions 13-15 of the terminal block. By disconnecting the three wires from the block, power to the FMI pump is cut off. For reconnection purposes, remember the green wire connects to position 13, white to 14, and black to 15.

3.3.4 The fluid connection to the FMI pump is located on the constant head chamber cap. The tube connecting solenoid valve 1 to the constant head chamber should be disconnected and replaced with a tube long enough to immerse in the sample vessel. The action of the peristaltic pump will draw sample.

3.4 If all flow sensors indicate adequate flow rates, begin initial calibration.

4. Calibration and Sampling

Three standard solutions are necessary to calibrate the CONTOC Monitor:

1. distilled or deionized water, 2. standard A, and 3. standard B.

Initial calibration must be carried out in the MANUAL mode; thereafter all recalibration will take place during the autocal cycle which occurs once every 24 hours while operating in the AUTO mode.

4.1 Initial Calibration - Follow these steps to calibrate initially and thereafter whenever (a) a new batch of standard is used; (b) the monitor has been down or in ST. BY for any length of time; or (c) when the restandardize meters indicate $\pm 50\%$.

4.1.1 Turn the mode selector switch to MANUAL, the sample selector switch to SAMPLE and sample distilled or deionized water for 30 minutes.

4.1.2 Set the specific conductance (Sp. Cond.) meter and the organic nitrate (ON) meter to zero by turning the CAL knob below each meter. (The ON meter will respond more slowly as a result of a damper in the circuit; wait a few minutes for a stable reading.)

4.1.3 Next turn the sample selector switch to STA.

4.1.4 The first sensor to respond to a change in sample will be the specific conductance cell; adjust the needle to read 10 mmhos/cm (full scale) with the SLOPE knob.

4.1.5 Within about 5 minutes the ON sensor will respond to standard A. Adjust the meter needle to read 50 mg/L (center scale) and wait for a stable reading.

4.1.6 After 15 minutes the total organic carbon (TOC) sensor should be responding steadily to standard A. Set the needle to 150 mg/L (center scale) with the CAL knob.

4.1.7 Now turn the sample selector switch to STB. Within 15 minutes the Sp. Cond. and the ON meter should return to zero and movement up the TOC scale should be observed.

4.1.8 Adjust the TOC meter to 300 ml/L (full scale) with the SLOPE knob.

4.1.9 The monitor is now calibrated for operation in the MANUAL mode. For operation in the AUTO mode return the sample selector switch to STA.

4.1.10 When the Sp. Cond. meter is showing full scale deflection and both the ON and TOC meters are back at center scale, turn the Mode selector switch to AUTO. The Servo motors will engage, and the restandardize meters will calibrate to standard A at the CAL and SLOPE settings that have just been selected.

4.1.11 Return the sample selector switch to SAMPLE. Within 24 hours the autocal cycle will recalibrate the monitor.

4.2 Sampling in the AUTO mode

Sample will circulate through the monitor while operating in the AUTO mode for 23 1/2 hours a day. At the beginning of the autocal cycle the sample flow will be shut off and Standard A will circulate through the monitor. During this time both the SAMPLE and the STA light will be on and the chart recorder should show a sharp red line indicating the reversed polarity to the ON cell. (If the preceding sample curve has been low a marked peak will appear as all sensors respond to standard A).

4.3 Varying the ON Cell Potential

The organic nitrate cell consists of a silver cathode - a platinum anode and a sealed silver chloride reference electrode. An applied potential of -0.9V has been selected for this particular cell. During the course of operation, however, there may be a necessity

to change the applied potential, as a replacement component may change the cell properties.

Circuit board #10, which controls the applied potential is accessible from the front or back of the monitor.

Attach a voltmeter to the two top prongs of the circuit board and with a small screw driver rotate the outside pot which varies the applied potential.

4.4 Selecting The ON Applied Potential

The ideal applied potential to the ON cell is that at which positive interference from nitrate ion and negative interference from sulfide ion are both at a minimum.

4.4.1 When the monitor is calibrated sample distilled or deionized water and with the CAL knob increase the reading in water from zero to 10 mg/L. Over a range -0.7V to -1.2V the response to water should not vary more than one division in either direction from 10 mg/L. Record the meter reading at about 0.05V intervals.

4.4.2 Next sample standard A. The ON response at -0.9V should be about 60 mg/L. The response of the meter to changes in applied potential is faster than to changes in calibration but wait at least a minute between 0.05V changes to take readings. Return to -0.9V and sample water for five minutes.

4.4.3 Prepare a solution 0.065M KNO_3 and sample for a few minutes after the specific conductance meter registers full response. Vary the applied potential first in the less negative direction and then in the more negative direction. Record ON readings every 0.05V until a change in response of more than 2 mg/L is seen, then take readings every 0.01V.

Return the applied potential to $-0.9V$ and sample water for five minutes. If there is any change in the ON response to water at this point, record this change. Do not adjust calibration.

4.4.4 Prepare a 100 mg/L sulfide solution by dissolving 0.75g $Na_2S \cdot 9H_2O$ in 1 liter water. You may wish to make this solution alkaline by adding 100 ml 10N NaOH and diluting to 1 liter. Prepare this solution immediately prior to use as solutions of sulfide ion are not stable. Do not use a commercially prepared sulfide standard for this test or any anti-oxidant buffers in preparing this solution. Sample the 100 mg/L S^{2-} solution and vary the potential first in the more negative direction and then in the less negative direction. Record the ON readings as in preceding samples. Return the sample to water and note the position the meter returns to after this test.

4.4.5 On linear graph paper plot the ON response versus the applied potential. At some point, most likely a range of 0.1V to 0.2V at which the negative interference from sulfide ion (readings below 10) and the positive interference from nitrate ion (readings above 10) are both at a minimum. This is the ideal applied potential to the ON cell.

5. Maintenance

In a continuous on-line monitor, some components will require more and some less maintenance than they would with regular bench-top use. Outlined below is a maintenance schedule which a trained operator can carry out.

5.1 Fluidics

5.1.1 Peristaltic Pump Lubrication: Initial lubrication of rollers and pressure plates with high vacuum or silicone grease and thereafter monthly lubrication is adequate. Weekly lubrication of tubing and pressure plates with silicone oil is advised.

5.1.2 Pump Tubing Replacement: For best results, change pump tubing monthly or when flow rates begin to vary significantly. See Trouble-shooting. The 059" ID silicone rubber tubing is available from Orion, product #321-059. The 030" ID Viton tubing is available from Elkay Products, Cat. no. LK116-0535-070.

5.1.3 All Other Tubing: Can be used indefinitely; replace only when showing cracks or obstructed by precipitate.

5.2 Sensors

5.2.1 TOC Cell: It may be necessary to add TOC internal filling solution once a week. To do this unscrew the white cap from the electrode barrel and remove the red internal electrode. Add filling solution and replace the internal. Screw the cap down tightly; excess solution will flow out the vent hole as you do this.

5.2.2 TOC Cell: It is advisable to replace the membrane once a month. Unscrew the flow through cap from the bottom of the

electrode barrel and discard the internal filling solution. Place the new membrane on top of the o-ring, membrane side down, and screw the cap back onto the barrel. The filling solution can be replaced as described above, in Sec. 5.2.1.

5.2.3 ON Cell: The prescribed maintenance for the ON cell is the reversed polarity feature of the autocal cycle. Replace filling solution every 2-3 weeks, more or less depending on the nature of the sample stream.

5.2.4 Conductivity Cell: Requires no maintenance.

5.3 Standards/Reagents

5.3.1 Standard A. Based on an approximate use of 50 mls per day in the autocal cycle and 50 mls for the initial calibration, 1 liter of standard A should last 19-20 days. (Replace every 20 days.)

5.3.2 Standard B. Based on a use of 50 mls for initial calibration every 19 days, 1 liter of standard B should last 380 days. (Replace monthly.)

5.3.3 Reagents. All reagents are added to the system at approximately the same rate. At an estimated rate of 8 mls/hr for non stop use, 5 gallons of reagent should last 98 days. (Replace every three months.)

6. Trouble-shooting

6.1 Problem: Flow Fault

6.1.1 What to check:

6.1.1.1 Reagent/Standard levels.

6.1.1.2 Fluid channels passing flow sensor #1.

6.1.1.3 Fluid channels passing flow sensor #2.

6.1.1.4 Fluid channels passing flow sensor #3.

6.1.1.5 Fluid channels passing flow sensor #4.

6.1.1.6 Side panel fluid channels.

6.1.1.7 Pump tubing.

6.1.2 How to check:

6.1.2.1 Reagent/Standard levels. Fluid levels are not visible through cubitainers, but a gentle lift will tell you if the reagent volume is sufficient. All ends of sampling tubes should be weighted so that there is no possibility of the tube floating above the liquid surface.

6.1.2.2 Fluid channels passing flow sensor #1. Flow sensor #1 senses the acid sample stream emerging from the inorganic carbon stripper before it enters the cold U.V. chamber. An obstruction anywhere in the line before or after the flow sensor will cause a flow fault. Check for flow at these points: Before and after the pumps of sample line #2 and reagent line #2; at the inlet and outlet ports of the stripper, flow sensor, cold U.V.

chamber, hot U.V. chamber, mixer #2, and the CO₂ electrode. Wherever you find an obstruction, clean out the involved channels with a syringe. If the obstruction is a precipitate it may often need to be dissolved in a mildly basic solution. Wash these channels with water and resume sample/reagent flow.

6.1.2.3 Fluid channels passing flow sensor #2. Flow sensor #2 senses the basic sample stream emerging from the stripper before it goes to waste. Check flow at these points: before and after the pumps of sample line #3 and reagent line #4; and the inlet and outlet ports of the stripper and the flow sensor itself. A mildly acid solution may be used to clean out channels of the basic sample line. Rinse channels well with deionized water before returning to sample reagent flow.

6.1.2.4 Fluid channels passing flow sensor #3. Flow sensor #3 monitors the flow of reagent line #4 (reducing reagent) as it emerges from the pump and before it enters mixer #2. An obstruction anywhere in the channels before or following the flow sensor could stop flow.

Check flow at these points: before and after the pump of reagent line #4; inlet and outlet ports of flow sensor #3, mixer #2 and the CO₂ electrode. Check flow sensor #1, an obstruction in the acid sample line could cause back flow in reagent line #4.

6.1.2.5 Fluid channels passing flow sensor #4. Flow sensor #4 senses the flow of the sample/EDTA reagent mixture as it emerges from the ON cell before it goes to waste. An obstruction in either sample line #1, reagent line #1, the conductivity cell, mixer #1, the ON cell or flow sensor #4 itself could trigger a flow fault. Check flow at the inlet and outlet ports of all these components.

6.1.2.6 Side panel fluid channels. Check flow at the inlet and outlet ports of the following channel components: linear membrane filter, solenoid valves #1 and #2, the FMI pump, the constant head chamber and the sample separating block. All components may be cleaned out by force of a syringe except the linear membrane filter. If flow is blocked at the linear membrane filter replace with filter.

6.1.2.7 Occasionally the pump tubing shoulders will become detached from the tubing, causing irregular flow. Replace the pump tubing in question with a new piece. The old tubing can be repaired, however, providing the tubing itself is still in good condition. To do this clean and dry the surfaces of both tubing and shoulder, and place a dab of silicon rubber adhesive on the tubing at the spot where the shoulder is to be positioned. Slide the shoulder over spot and move it back and forth slightly to distribute the adhesive over the entire inner surface of the shoulder. Do not wipe away the excess adhesive that flows outside the shoulder, as it will strengthen the bond. Avoid getting adhesive inside or on the ends of the tubing.

6.2 Problem: Poor ON response

6.2.1 What to check:

6.2.1.1 Calibration.

6.2.1.2 Sample and reagent flow.

6.2.1.3 Connections.

6.2.1.4 Reference electrode.

6.2.1.5 Reagents.

6.2.1.6 Electronic.

6.2.2 How to Check:

6.2.2.1 Calibration. Sample water and standard. If the autocal cleaning cycle has not operated for several days, put monitor in AUTO mode for 24 hours, then recheck standards.

6.2.2.2 Sample and reagent flow. If the flow meters indicate within $\pm 50\%$ of the original calibration there is no flow problem. Make sure sample and reagent lines are going into the correct samples and reagents. For flow fault see Sec. 6.1.

6.2.2.3 Connections. The cables from the electrodes themselves lead to a narrow panel at the lower left side corner of the back of the sensor panel. The two far right screws connect to the ON electrodes. Check to see if these are connected.

6.2.2.4 Reference electrodes. Occasionally you may need to replace the internal filling solution in the sealed reference electrode. Remove the sensor panel cover. To remove ON sensor block, first unscrew the 3 phillips head screws fastening the block onto the panel. Pull gently on the block until it is several inches away from the panel, the cables have several inches play in them. Unscrew the top screw fastening the reference electrode bracket to the block and remove bracket and electrodes together. To refill the sealed reference electrode, simply remove the white cap and fill with 4 M KCl, saturated with AgCl. Occasionally the platinum reference electrode may need cleaning. Rub the pellet surface evenly with an electrode polishing strip. Rinse electrodes and replace in the sensor block, check the o-ring seal and return the entire assembly to the sensor panel.

6.2.2.5 Reagents. Reagents themselves may have become contaminated. Replace with new reagents.

6.2.2.6 Electronics. Consult an electrical engineer familiar with the CONTOC Monitor. Call Orion.

6.3 Problem: Poor TOC response

6.3.1 What to check:

6.3.1.1 Flow through electrode.

6.3.1.2 Electrode tilt.

6.3.1.3 Filling solution level.

6.3.1.4 Membrane and filling solution.

6.3.1.5 Electrode itself.

6.3.1.6 Reagents.

6.3.1.7 Connections.

6.3.1.8 Electronic.

6.3.2 How to check:

6.3.2.1 Flow through electrode. Flow sensors 1, 2, and 3 should all be within acceptable limits, $\pm 50\%$ variance from initial calibration. The appearance of the sample/reagent flow from the electrode will be interspersed with bubbles, which are visible as they travel up the waste line.

6.3.2.2 Electrode Tilt. The electrode should be tilted so that the outlet tube is slightly higher than the inlet.

6.3.2.3 Filling solution level. The level of filling solution should be no lower than one inch from the white cap.

6.3.2.4 Membrane and filling solution. If none of the above treatments solves the problem, replace membrane and filter as in section 5.2.

6.3.2.5 Electrode itself. Replace with a new, bench-tested, Orion #95-01 CO₂ electrode.

6.3.2.6 Reagents. Reagents themselves may have become contaminated. Replace with new reagents.

6.3.2.7 Connections. The TOC pre-amp is designed to take two inputs. The CO₂ electrode connector should be in the inside and a shorting strap should be connected to the outside input.

6.3.2.8 Electronic. Consult an electrical engineer familiar with the CONTOC Monitor. Call Orion.

6.4 Problem: Poor response in conductivity cell

6.4.1 What to check:

6.4.1.1 Sample Flow.

6.4.1.2 Connections.

6.4.1.3 Response to known solutions.

6.4.1.4 Response after cleaning.

6.4.1.5 Electronic.

6.4.2 How to check:

6.4.2.1 Sample flow. Flow sensor #4 will indicate within $\pm 50\%$ if sample flow is okay. If not, force fluid through the channel with a syringe.

6.4.2.2 Connections. Two U-shaped electrical connectors are screwed into the side of the conductivity cell. If these are loose, results will be nil to erratic. Tighten these connectors.

6.4.2.3 Response to known solutions. If your standard has become contaminated, or if the platinum sensors in the cell have been coated, you can check this by sampling a solution of $2 \times 10^{-3} \text{ M KCl}$. The conductivity of this standard solution should read 2.8 - 3.0 mmhos/cm.

6.4.2.4 Response after cleaning. With a small syringe inject, a 1:1 solution of nitric acid and water. Follow by several injections of water and repeat step 6.4.2.3.

6.4.2.5 Electronics. Consult an electrical engineer familiar with the CONTOC Monitor. Call Orion.

6.5 Problem: No Power

6.5.1 What to check:

6.5.1.1 Plug.

6.5.1.2 Fuse.

6.5.1.3 Power source adapter.

6.5.2 How to check:

6.5.2.1 Fuse. Next to the flow sensor panel on the upper right inside panel are two fuse cases. The upper fuse case contains a 5 amp SLO-BLO fuse. Unplug monitor and remove fuse. Replace the blown fuse and plug in the monitor.

6.5.2.2 Power source adapter. Consult an electronic engineer.

Appendix A

Left Inside Panel Description

1. Standard Compartment: Two polyethylene liter bottles containing standards A and B fit into this shelf located at the very top of the panel. Two .031" silicon rubber tubes fit into the standard bottles and lead into solenoid valve 2.
2. Solenoid Valve 2: Located directly below the standard compartment, solenoid valve 2 channels either STA and STB, and leads to solenoid valve 1.
3. FMI Pump: The FMI lab pump draws sample from the cellulose filter and delivers to the constant head chamber.
4. Constant Head Chamber: The constant head chamber, located at bottom left of the inside panel, fills via a silicon rubber tube from the FMI pump at the bottom and samples from the top.
5. Solenoid Valve 1: Solenoid valve 1 channels sample (via peristaltic pump action) from the constant head chamber or standard compartment via solenoid valve 2.
6. Sample Separating Block: The clear plastic sample separator block draws from solenoid valve 1 and delivers through fluid channels to the sensor panel via the peristaltic pump.
7. Linear Membrane Filter: Sample enters the filter at the bottom from an outside pressurized source and flows out the side to the FMI pump and out the top to the outlet port and waste fluid sensor panel description.

Sensor Package

1. Cold U.V. Chamber: The cold U.V. chamber consists of a quartz tube

coiled around a U.V. lamp encased in an open stainless steel cylinder. The chamber is cooled by means of a fan, which draws hot air out through a vent tube. (The power sources for both U.V. lamps are located directly behind the cold U.V. chamber on the opposite side of the panel. The lamps can be turned on and off by a separate switch.) Acid sample enters the chamber through a silicon rubber tube, via flow sensor #2, which slips over a rigid plastic tube connected to the quartz coil. Sample leaves the chamber through a Viton tube leading to the hot U.V. chamber.

2. Heater: The heating panel directly below the cold U.V. chamber maintains the entire fluids/sensor compartment at constant temperature.

3. CO₂ Electrode: The CO₂ electrode is the Orion #95-01 standard electrode with a flow-through cap. Two stainless steel tubes lead into a small sample chamber which comes in contact with the gas-permeable membrane. An .031" ID silicon rubber tube slips over the narrow stainless steel inlet tube; this tube carries reagent/sample mixture from mixer block 2 into the sample chamber of the electrode. An 059" silicon rubber tube slips over the larger stainless steel tube and carries analyzed sample to waste. The electrode is mounted at a slight angle to allow bubble clearance through the flow-through cap. The entire electrode may be removed from the bracket by loosening the set screw and firmly pulling upwards.

4. Mixer Block 2: Mixer block 2 mixes oxidized acid sample with reducing reagent.

5. Conductivity Cell: Sample line 1 enters the conductivity cell from the bottom and flows upward.

6. Mixer Block 1: Mixer block 1 combines sample flowing from the conductivity cell with EDTA reagent before it enters the polarographic ON cell.

7. Polarographic ON Cell: Sample reagent mixture flows from mixer block 1 through the silver cathode block and into the reference electrode block. The two blocks interface by means of an o-ring seal, as do

the platinum and sealed reference electrodes to the fluid channel of the reference block. An acrylic clamp holds the reference electrodes and secures them into the reference block with a screw. Two screws hold the cathode block to the reference. The entire assembly is mounted on to the panel at a slight angle.

8. Flow Sensors: Four flow sensors are mounted onto an aluminum L-shaped block which is mounted at the top of the fluid sensor panel. Flow sensor #1 monitors the EDTA reagent sample mixture after it leaves the ON cell on its way to waste; #2 monitors the acid sample after it emerges from the inorganic carbon stripper; #3 monitors the base sample between the stripper and waste; and #4 monitors the flow of the reducing reagent before reaching mixer block 2.

9. Inorganic Carbon Stripper: The inorganic carbon stripper consists of 2 stainless steel cylindrical plates into which a shallow coiled groove has been drilled. These two plates are mirror images of one another and fit together with a sheet of semipermeable membrane between them, forming two contiguous fluid paths. The acid reagent/sample mixture enters the top side of the stripper and flows through the coiled channel while the base reagent/sample mixture enters the bottom side and flows in the opposite direction. The silicon rubber tubes containing fluid connect to the stripper by simply slipping over the plastic inlet and outlet tubes.

10. Hot U.V. Chamber: The hot U.V. chamber consists of a U.V. lamp inserted into a coiled quartz tube which is potted into solid stainless steel block. Viton tubing leads in and out of the block by fittings which make an o-ring seal onto a channel which connects to the quartz coil.

11. Sage Model 370M Pump: The pump on the left carries sample through .059" ID silicon rubber tubing. The pump on the right carries reagents through .031" ID cured ElKay tubing which has been adapted for the 370M pump. Black pressure plates are used throughout. The pump lids close to open clamps on the tubing and to provide pressure for pumping. Tubing plates and rollers are lubricated in silicon oil for longer wear.

12. Waste Block: (not pictured) .059" ID silicon rubber tubing from flow sensors 1 and 3 and from the CO₂ electrode run through openings in the panel to a PVC block which organizes the waste lines into a large tygon tube which carries the wastelines out of the monitor to a suitable receptacle.

13. Cover: (not pictured) The cover protects the fluid/sensor compartment and provides an area of constant temperature and electrical shielding. It screws on to the panel at each of four corners.

Appendix B

Reagents and Standards

Standards

For reliable standards prepare the following stock solutions and dilute volumetrically.

1. 1000 mg/L N picric acid: Weigh out 5.45g picric acid and place in a 1 liter volumetric flask. Dilute to volume with distilled or deionized water. Stir with a teflon coated stir bar on a magnetic mixer for at least one hour.

Note: The amount of water in picric acid is not only desirable but variable. Therefore the actual concentration of the 1000 mg/L N picric acid solution should be determined by an acid-base titration.

Pipet 50 mls of stock solution into a 100 ml glass beaker, add a stir bar and place on a magnetic stirrer. Insert a calibrated pH electrode and begin adding 0.1 N NaOH, in 1 ml increments at first, and then in 0.1 ml increments when the pH begins to rise sharply. For a 1000 ppm N solution the endpoint should be at 12.0 mls.

2. 1M ethylene glycol: Take a volume of about 60 ml ethylene glycol and pour it through an ion exchange column containing mixed bed resin. Pipet 55.76 mls of the treated ethylene glycol into a 1 liter volumetric flask. Dilute to volume with distilled or deionized water.

3. 1M potassium nitrate: Place 101.1g reagent grade potassium nitrate, KNO_3 , in a 1 liter volumetric flask and dilute to volume.

Standard A: Pipet 50 mls 1000 mg/L N picric acid solution, or an appropriate amount from stock solution, 2.68 mls 1M ethylene glycol solution, and 65.0 mls 1M potassium nitrate solution into a 1 liter volumetric flask and dilute to volume with distilled or deionized water.

The resulting solution is: $1.19 \times 10^{-3}M$ picric acid, $2.68 \times 10^{-3}M$ ethylene glycol, and $6.5 \times 10^{-2}M$ potassium nitrate for a total composition of 50 mg/L N, 150 mg/L TOC, and a specific conductance of 10 mmhos/cm.

Standard B: Pipet 12.5 mls 1M ethylene glycol into a 1 liter volumetric flask and dilute to volume with distilled or deionized water. The resulting solution is $1.25 \times 10^{-2}M$ ethylene glycol, for a total composition of 0 mg/L N, 300 mg/L TOC, and a specific conductance of 0.

Reagents

EDTA Reagent: Directions for 1 liter reagent: In a one liter beaker add 150 mls 10N NaOH to about 400 mls distilled or deionized water (or 60g NaOH electrolytic pellets to 500 mls water). Stir over a magnetic stirrer and slowly add 372.24 g reagent grade disodium ethylene diamine tetraacetate, Na_2H_2 EDTA. Since heat will be generated in this reaction, allow time for the solution to cool. All of the acid may not be dissolved at this point, but it will go into solution as 10 N NaOH is added to adjust the pH to 11.0. Add 116.88g reagent grade sodium chloride, NaCl, stir to dissolve, transfer to a 1 liter flask and dilute to volume. The resulting solution is 1M EDTA and 2M NaCl.

Directions for 5 gallons reagent: In a five gallon container such as a cubitainer, place 2.85 liters 10 N NaOH (or 1135g NaOH pellets) and about 10 liters water. Stir solution with an industrial stirrer and slowly add 6.475 Kg disodium EDTA. Adjust the pH to 11.0 by adding 10 N NaOH. Add 2.212 Kg reagent grade NaCl and dilute to volume. Stir for several hours.

Reducing Reagent: Directions for 1 liter reagent: In a one liter volumetric flask place 106g reagent grade sodium hypophosphite, NaH_2PO_2 , and dilute to volume with distilled or deionized water. Stir over a magnetic stirrer for a few minutes to dissolve all the salt. The resulting solution is 1M NaH_2PO_2 .

Directions for 5 gallons reagent: In a 5 gallon container such as a cubitainer, place 2.006 kg reagent grade NaH_2PO_2 , dilute to volume and stir over a magnetic stirrer for 1/2 hour.

Acid Persulfate Reagent: Directions for 1 liter reagent: In a one liter volumetric flask containing about 500 mls distilled or deionized water, place 300 g Oxone monopersulfate compound (DOW Product) and stir over a magnetic mixer. While the solution is still cool add 55.5 mls concentrated sulfuric acid. Dilute to mark with water. The resulting solution is 0.488 M Oxone (0.244M KHSO_5) and 1 M H_2SO_4 .

Directions for 5 gallons reagent: In a 5 gallon container such as a cubitainer, place 10 liters water and 5.676 Kg Oxone, and stir for a few minutes over a magnetic stirrer. Add 1.05 liters concentrated H_2SO_4 and dilute to volume. Stir for 1/2 hour.

Base Reagent: Directions for 1 liter reagent: In a one liter volumetric flask place 500 mls distilled or deionized water and 62.4 g reagent grade NaOH electrolytic pellets or 156 mls 10 N NaOH. Stir to dissolve over a magnetic stirrer and let cool. Dilute to mark with water. The resulting solution is 1.56 M NaOH.

Directions for 5 gallons reagent: In a 5 gallon container such as a cubitainer place 10 liters distilled or deionized water and 1.181 Kg NaOH pellets or 2.95 liters 10 N NaOH. Stir for 1/2 hour and allow to cool. Dilute to volume with water.

TOC Internal Filling Solution

In a 1 liter volumetric flask dissolve 0.84g reagent grade sodium bicarbonate NaHCO_3 , 6.9g reagent grade sodium nitrite, NaNO_2 , 5.84g sodium chloride, NaCl , and 88.45 ml ethylene glycol, in distilled or deionized water. Dilute to volume. The resulting solution is 0.01 M NaHCO_3 , 0.10 M NaNO_2 , 0.10 M NaCl , and 1.58 M ethylene glycol.