

AD-A069 109 ARMY ARMAMENT RESEARCH AND DEVELOPMENT COMMAND ABERD--ETC F/G 19/6
AN ELECTRIC PRIMER-OPERATED FIRING PIN ACTUATOR FOR LARGE CALIB--ETC(U)
JAN 79 J J ROCCHIO, R A HARTMAN, N J GERRI

UNCLASSIFIED

ARBRL-MR-02897

SBIE-AD-E430 222

NL

| OF |

AD
A069109

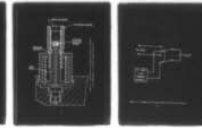
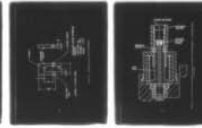
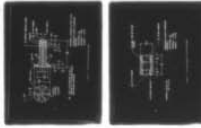
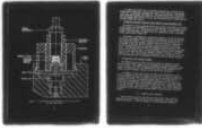
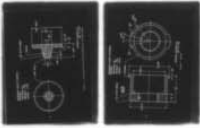

END
DATE
FILMED
6-79
DDC

① LEVEL III
Na

AD-E430222

MEMORANDUM REPORT ARBRL-MR-02897

(Supersedes IMR No. 485)

AN ELECTRIC PRIMER-OPERATED FIRING PIN
ACTUATOR FOR LARGE CALIBER GUNS

Joseph J. Rocchio
Richard A. Hartman
Norman J. Gerri

January 1979

DDC
RECEIVED
MAY 30 1979
B

AD A069109

DDC FILE COPY



US ARMY ARMAMENT RESEARCH AND DEVELOPMENT COMMAND
BALLISTIC RESEARCH LABORATORY
ABERDEEN PROVING GROUND, MARYLAND

Approved for public release; distribution unlimited.

79 05 02 011

Destroy this report when it is no longer needed.
Do not return it to the originator.

Secondary distribution of this report by originating
or sponsoring activity is prohibited.

Additional copies of this report may be obtained
from the National Technical Information Service,
U.S. Department of Commerce, Springfield, Virginia
22161.

The findings in this report are not to be construed as
an official Department of the Army position, unless
so designated by other authorized documents.

*The use of trade names or manufacturers' names in this report
does not constitute indorsement of any commercial product.*

UNCLASSIFIED

SECURITY CLASSIFICATION OF THIS PAGE (When Data Entered)

REPORT DOCUMENTATION PAGE		READ INSTRUCTIONS BEFORE COMPLETING FORM
1. REPORT NUMBER MEMORANDUM REPORT ARBRL-MR-02897	2. GOVT ACCESSION NO.	3. RECIPIENT'S CATALOG NUMBER
4. TITLE (and Subtitle) An Electric Primer-Operated Firing Pin Actuator for Large Caliber Guns.	5. TYPE OF REPORT & PERIOD COVERED Memorandum Report	
	6. PERFORMING ORG. REPORT NUMBER	
7. AUTHOR(s) Joseph J. Rocchio, Richard A. Hartman, Norman J. Gerri	8. CONTRACT OR GRANT NUMBER(s)	
9. PERFORMING ORGANIZATION NAME AND ADDRESS USA Ballistic Research Laboratory USA, ARRADCOM Attn: DRDAR-BLP Aberdeen Proving Ground, MD 21005	10. PROGRAM ELEMENT, PROJECT, TASK AREA & WORK UNIT NUMBERS 11162618AH80	
11. CONTROLLING OFFICE NAME AND ADDRESS USA Armament Research & Development Command USA Ballistic Research Laboratory (DRDAR-BL) Aberdeen Proving Ground, MD 21005	12. REPORT DATE JANUARY 1979	
	13. NUMBER OF PAGES 31	
14. MONITORING AGENCY NAME & ADDRESS (if different from Controlling Office)	15. SECURITY CLASS. (of this report) Unclassified	
	15a. DECLASSIFICATION/DOWNGRADING SCHEDULE	
16. DISTRIBUTION STATEMENT (of this Report) Approved for public release; distribution unlimited.		
17. DISTRIBUTION STATEMENT (of the abstract entered in Block 20, if different from Report)		
18. SUPPLEMENTARY NOTES This report supersedes Interim Memorandum Report No. 485 dated March 1976.		
19. KEY WORDS (Continue on reverse side if necessary and identify by block number) primer actuator M35 firing lock replacement electric primer ignition systems artillery firing techniques		
20. ABSTRACT (Continue on reverse side if necessary and identify by block number) A device which uses an electrically fired primer (M52A3B1) to actuate the mechanical firing pin in the 155-mm, 175-mm, and 8-inch gun systems has been developed. It may be used as a direct replacement for the standard lanyard-operated cannon firing mechanism, M35. The advantage of this device is that the standard percussion primers (M82 or similar) used in these gun systems may be actuated remotely (i.e., without the use of the lanyard), under the control of an electronic sequence timer and/or computer system. The data acquisition process is simplified because the		

UNCLASSIFIED

SECURITY CLASSIFICATION OF THIS PAGE(When Data Entered)

No. 20 (ABSTRACT) Cont'd:

beginning of the ignition sequence may now be time-correlated with other events. More accurate timing of ignition delays results because the initiation signal to the electric primer serves as a reference point, and the delay between application of the initiation voltage and the beginning of output from the percussion primer is less than a millisecond.

X

(5)

UNCLASSIFIED

SECURITY CLASSIFICATION OF THIS PAGE(When Data Entered)

TABLE OF CONTENTS

	<u>Page</u>
LIST OF ILLUSTRATIONS.	5
I. INTRODUCTION	7
II. ACTUATOR DESIGNS AND OPERATING PROCEDURES.	7
A. Firing Pin Actuator for the 155-mm, M199 Cannon.	7
B. Firing Pin Actuator for the 155-mm, M185 Cannon.	9
C. Firing Pin Actuator Compatible with Cannon Firing Mechanism, M35.	16
D. Initiation of the Electric Primer.	16
III. RESULTS AND DISCUSSION	16
IV. RECOMMENDATION	23
ACKNOWLEDGEMENTS	23
REFERENCES	25
APPENDIX	27
DISTRIBUTION LIST.	29

ACCESSION for		
NTIS	White Section	<input checked="" type="checkbox"/>
DDC	Buff Section	<input type="checkbox"/>
UNANNOUNCED		<input type="checkbox"/>
JUSTIFICATION _____		
BY _____		
DISTRIBUTION/AVAILABILITY CODES		
Dist.	AVAIL.	and/or SPECIAL
A		

LIST OF ILLUSTRATIONS

<u>Figure</u>		<u>Page</u>
1	Cross-Section of Firing Lock for the M199 Cannon and Cannon Firing Mechanism, M35.	8
2	Adapter for Firing Electrode and M52A3B1 Electric Primer Vent Plug	10
3	Cross-Section of Assembled Firing Pin Actuator for the M199 Cannon	11
4	Modified Firing Electrode Adapter for the M185 Cannon.	12
5	Vent Plug for Firing Electrode Adapter for the M185 Cannon.	13
6	Housing.	14
7	Cross-Section of Assembled Firing Pin Actuator for the M185 Cannon	15
8	Vent Plug for M35 Replacement.	17
9	Electrode Adapter for M35 Replacement.	18
10	Retaining Collar for M35 Replacement	19
11	Cross-Section of Assembled Firing Pin Actuator, M35 Replacement, in the M199 Cannon Firing Lock	20
12	Cross-Section of Assembled Firing Pin Actuator, M35 Replacement, in the M185 Cannon Firing Lock	21
13	Schematic of Firing Circuit for Firing Pin Actuator. .	22
14	Experimentally Measured Actuation Time: Plot of Electric Primer Initiation Voltage and Output Pressure of M82 Primer (in M199 Spindle) vs. Time.	24

PRECEDING PAGE BLANK

I. INTRODUCTION

Experimental interior ballistics often requires the initiation of the ignition event to be time-coordinated with events in the data acquisition process. This may be necessary for accurate determination of ignition delay times or for control of instrumentation such as cameras or digital data acquisition systems. With gun systems which use electric ignition systems, the time-coordination of the igniter function is readily accomplished. Many large caliber gun systems, such as the 155-mm, 175-mm, and 8-in. howitzers, use a percussion primer in the ignition train. This is initiated in the field by pulling a lanyard which releases a firing pin in the firing lock assembly. In experimental programs, the lanyard has sometimes been replaced with a solenoid operating mechanism. While this does allow a degree of time sequence control with electronics, there are drawbacks; the large variations which occur in the operating time of the solenoid (up to hundreds of msec.) do not allow sequence control accurate enough for many applications. Another approach has been to substitute an electrically initiated primer for the percussion primer. The electrically initiated replacement should have exactly the same level and rate of output because these are often critical to the overall function of the gun ignition system. In practice, this is not often possible.

During a recent investigation of the ignition train used in the Zone 8 charge for the M198, 155-mm howitzer, it was necessary to actuate the M82 percussion primer under the control of an electronic sequence timer. In order to capture the event with high speed film, the initiation of the igniter had to be precisely coordinated with the cameras. Because the M82 primer is a critical part of the ignition train under study, an electrically initiated primer could not be substituted. To meet this need, a device was developed which uses an electrically actuated M52A3B1 primer to operate the mechanical firing pin for the M82 primer.

The initial device was designed for the firing lock of the M199 cannon for the M198 howitzer. A modification was made to adapt it to the firing lock for the M185 and M126, 155-mm howitzers. More recently, the device was redesigned to be a physical replacement for the cannon firing mechanism, M35 (Part No. 8767205), which is used on the 155-mm, 175-mm and 8-in. gun systems. A description of the construction of the three adaptations of this device as well as the procedures for operation are presented.

II. ACTUATOR DESIGNS AND OPERATING PROCEDURES

A. Firing Pin Actuator for the 155-mm, M199 Cannon

A cross-sectional view of the standard cannon firing mechanism, M35, and firing lock for the breech of the M199 cannon is shown in Figure 1. The firing pin is driven by a spring loaded piston which is released

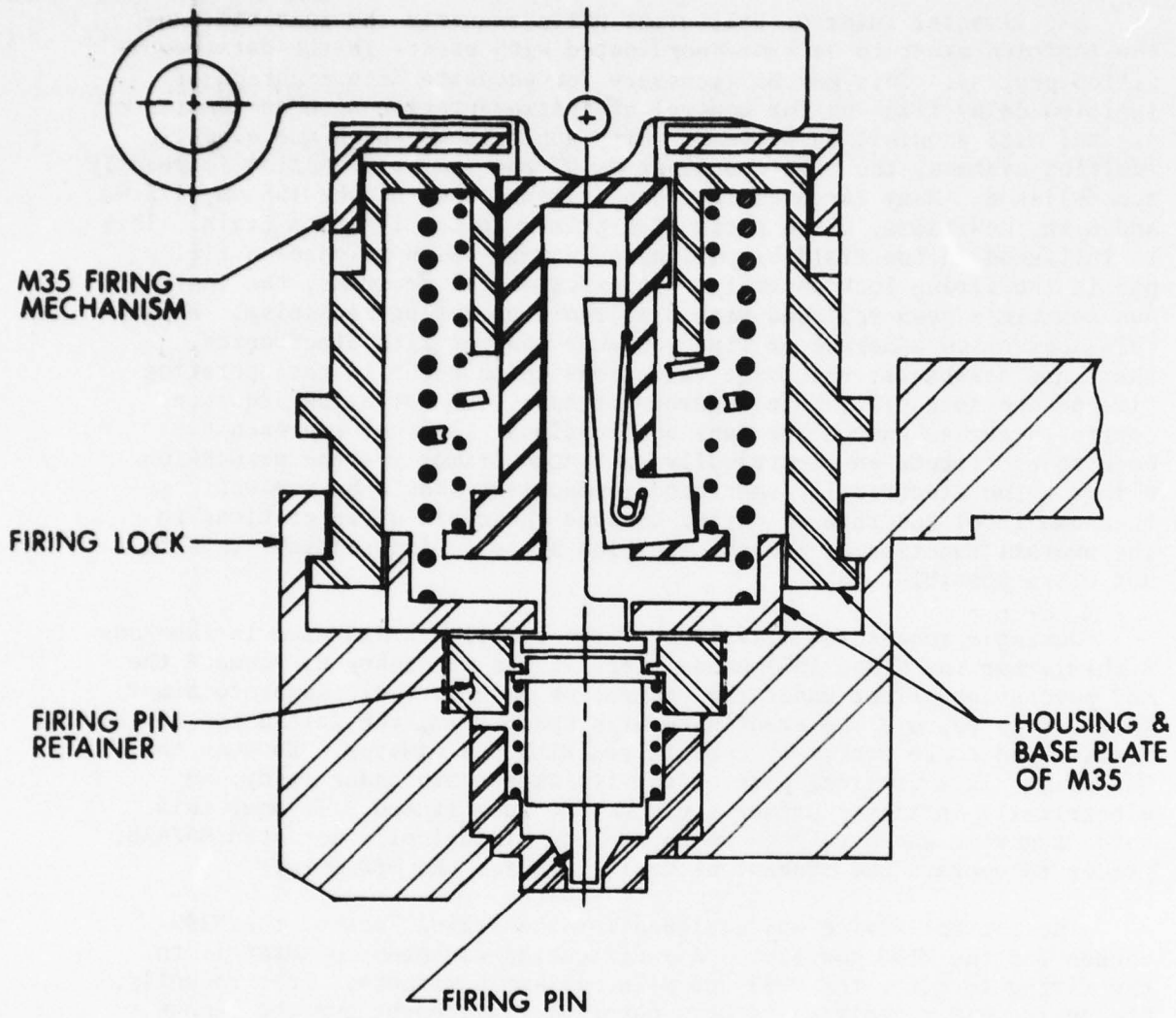

Figure 1. Cross-Section of Firing Lock for the M199 Cannon and Cannon Firing Mechanism, M35

when the lanyard is pulled.

The device described in this report operates by driving the firing pin with the gas generated by an M52A3B1 electric primer instead of the spring-actuated piston of the M35.

To accomplish this, an adapter was designed to hold the electric primer and the firing electrode as shown in Figure 2. The larger cavity is threaded to accept a firing electrode (Figure 3) for the M52A3B1 electric primer. The electrode is manufactured by Technoproducts, Inc.* It is equipped with a standard BNC connector for attaching the cable which carries the firing voltage. A threaded vent plug (Figure 2) is used to retain the electric primer in proper alignment with the electrode. The primer end of the electrode adapter is threaded to fit the cavity for the firing pin retainer (Figure 1).

Figure 3 depicts a cross-sectional view of the firing pin actuator. The physical relation between the firing pin, vent plug, M52A3B1 primer, and firing electrode is shown. A rubber O-ring (Figure 3) is placed around the electrode to position the electric primer (optional).

In operation, the firing electrode is threaded into the electrode adapter, the O-ring is placed around the tip of the electrode, and an electric primer is loaded into the cavity. The vent plug is then threaded into place and the entire adapter assembly is threaded into the firing lock in place of the firing pin retainer (Figure 1).

B. Firing Pin Actuator for the 155-mm, M185 Cannon

The firing lock for the M185 cannon does not have a threaded firing pin retainer as in the M199 cannon. Therefore, the electrode adapter (Figure 2) was modified as shown in Figure 4 and a new vent plug was constructed (Figure 5). These were both designed to fit within a housing (Figure 6) similar to that of an M35 firing mechanism (see Figure 1).

A cross-sectional view of the assembled device for the M185 cannon is shown in Figure 7. In operation, the primer vent plug is threaded into position in the electrode adapter. The adapter is then threaded into the housing until the bottom surface of the vent plug is just within the housing. An electric primer is placed in the adapter cavity and the firing electrode with an O-ring around the tip (optional) is threaded into position. The entire assembly is placed in the firing lock and given a half-turn to engage the locking lugs. The adapter is then screwed down into the housing until it is hand-tight against the bottom of the firing lock.

*Saratoga, CA 95070

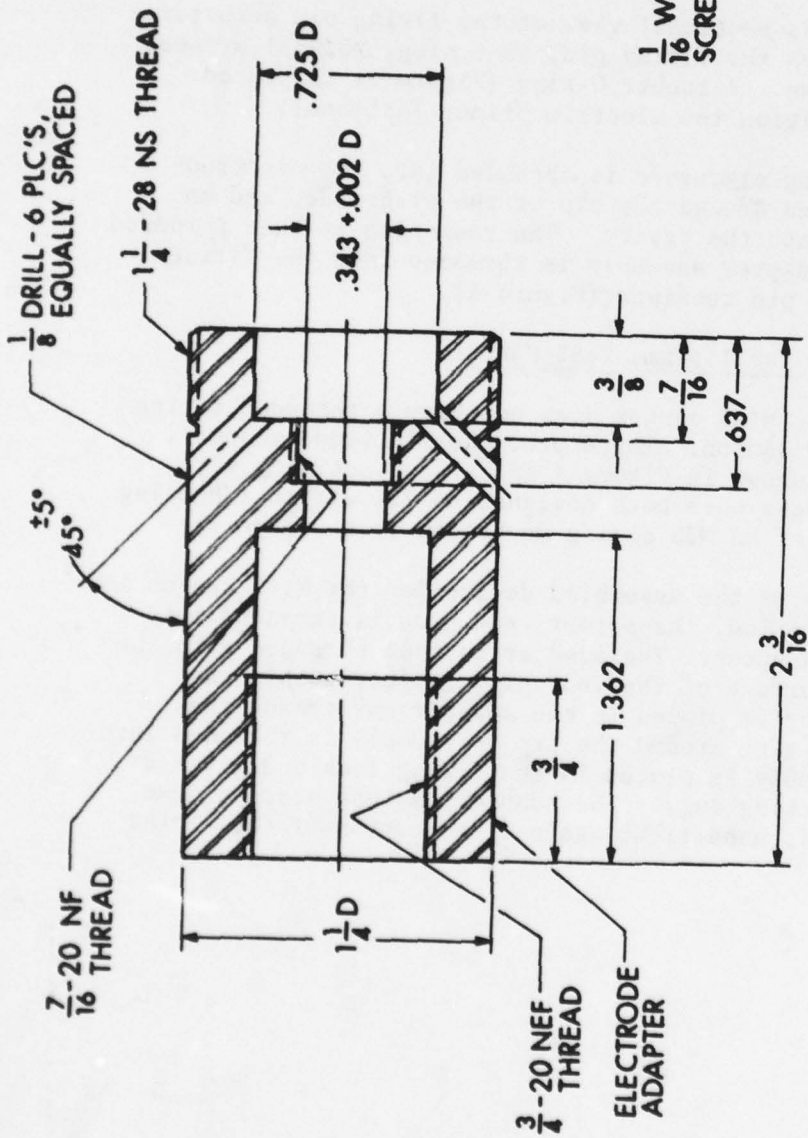

MATERIAL: ELASTUF 44

TOLERANCES UNLESS OTHERWISE SPECIFIED:

FRACTIONS $\pm \frac{1}{64}$

DECIMALS $\pm .002$

ANGLES $\pm 0^\circ 10'$

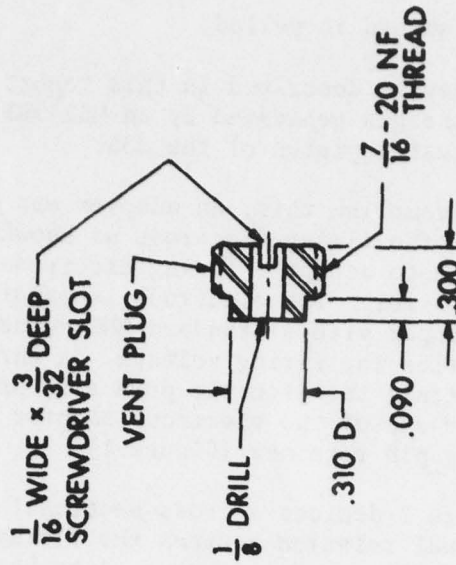

MATERIAL: ELASTUF 44
OR 17-4 PH

Figure 2. Adapter for Firing Electrode and M52A3B1 Electric Primer Vent Plug

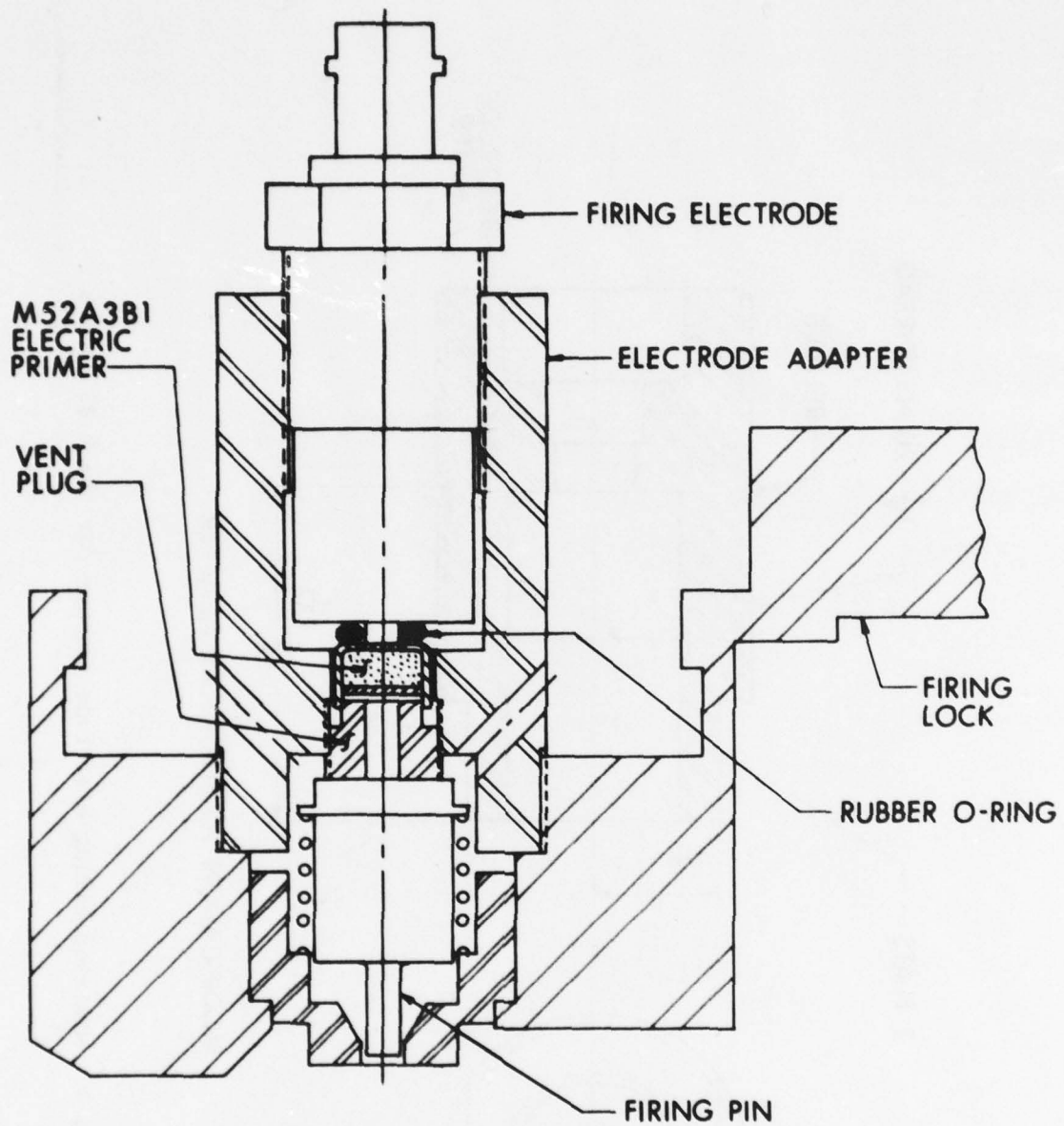
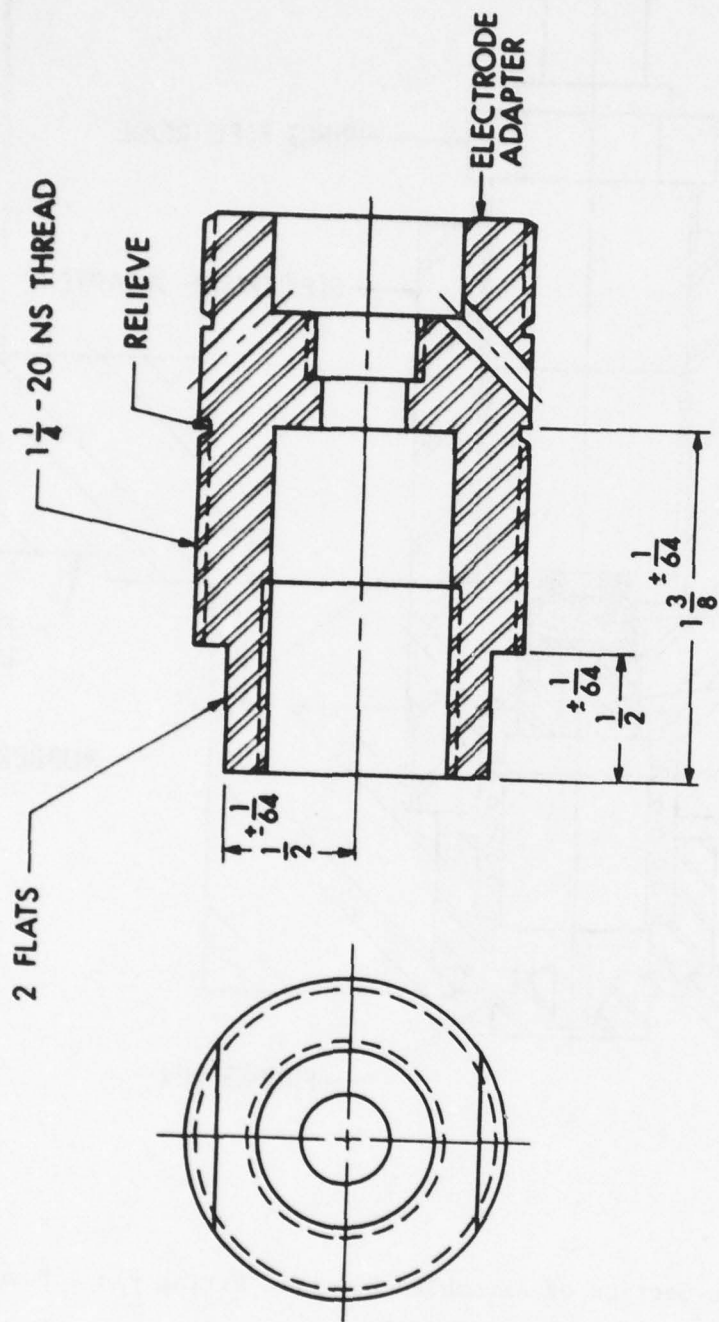

Figure 3. Cross-Section of Assembled Electric Firing Pin Actuator
for the M199 Cannon



MODIFICATION TO ELECTRODE ADAPTER

Figure 4. Modified Firing Electrode Adapter for the M185 Cannon

TOLERANCES UNLESS OTHERWISE SPECIFIED:

FRACTIONS $\pm \frac{1}{64}$
 DECIMALS $\pm .002$
 ANGLES $\pm 0^{\circ}10'$

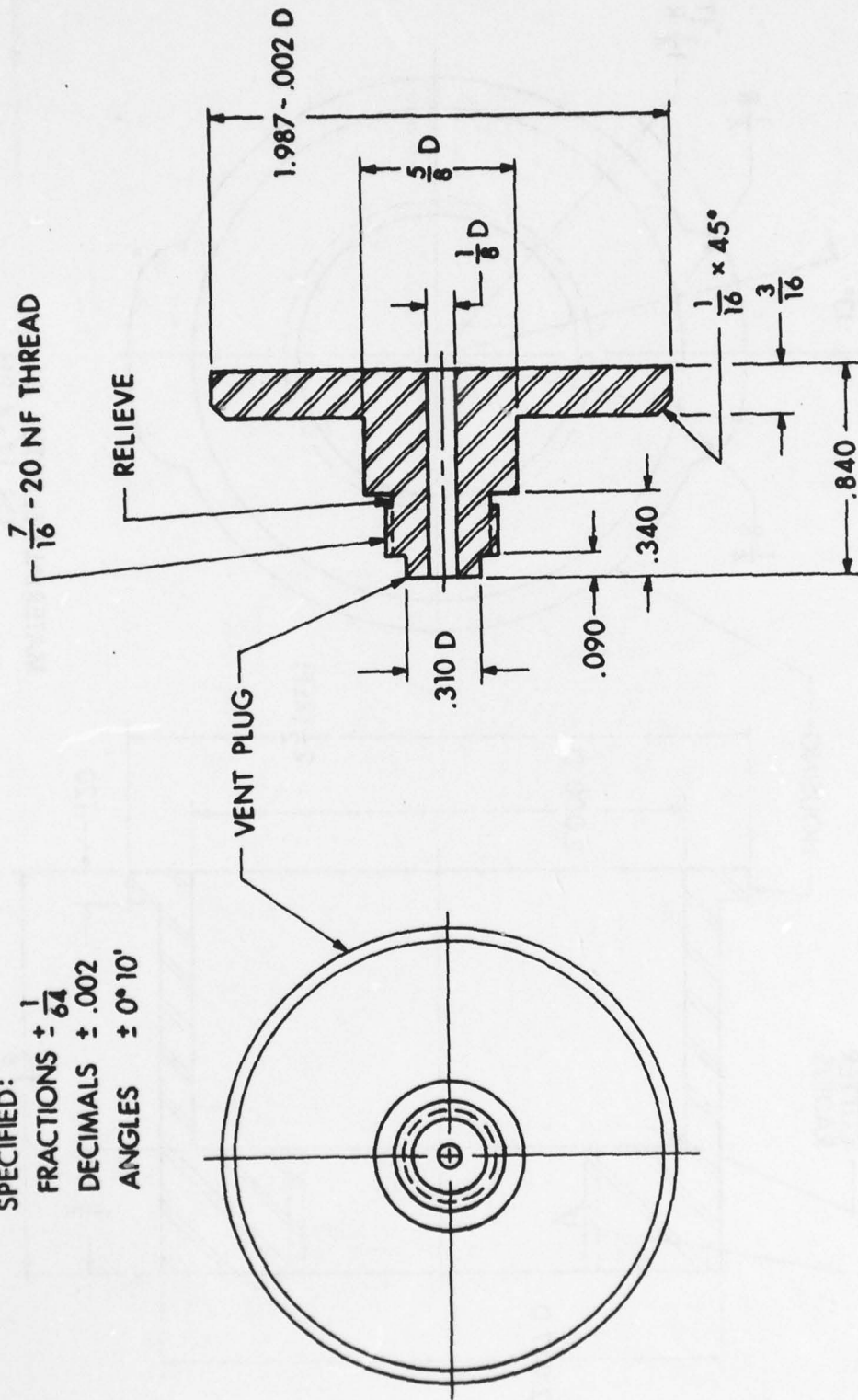

MATERIAL: ELASTUF 44
 OR 17-4 PH

Figure 5. Vent Plug for Firing Electrode Adapter for the M185 Cannon

TOLERANCES UNLESS OTHERWISE SPECIFIED:

- FRACTIONS $\pm \frac{1}{64}$
- DECIMALS $\pm .002$
- ANGLES $\pm 0^{\circ} 10'$

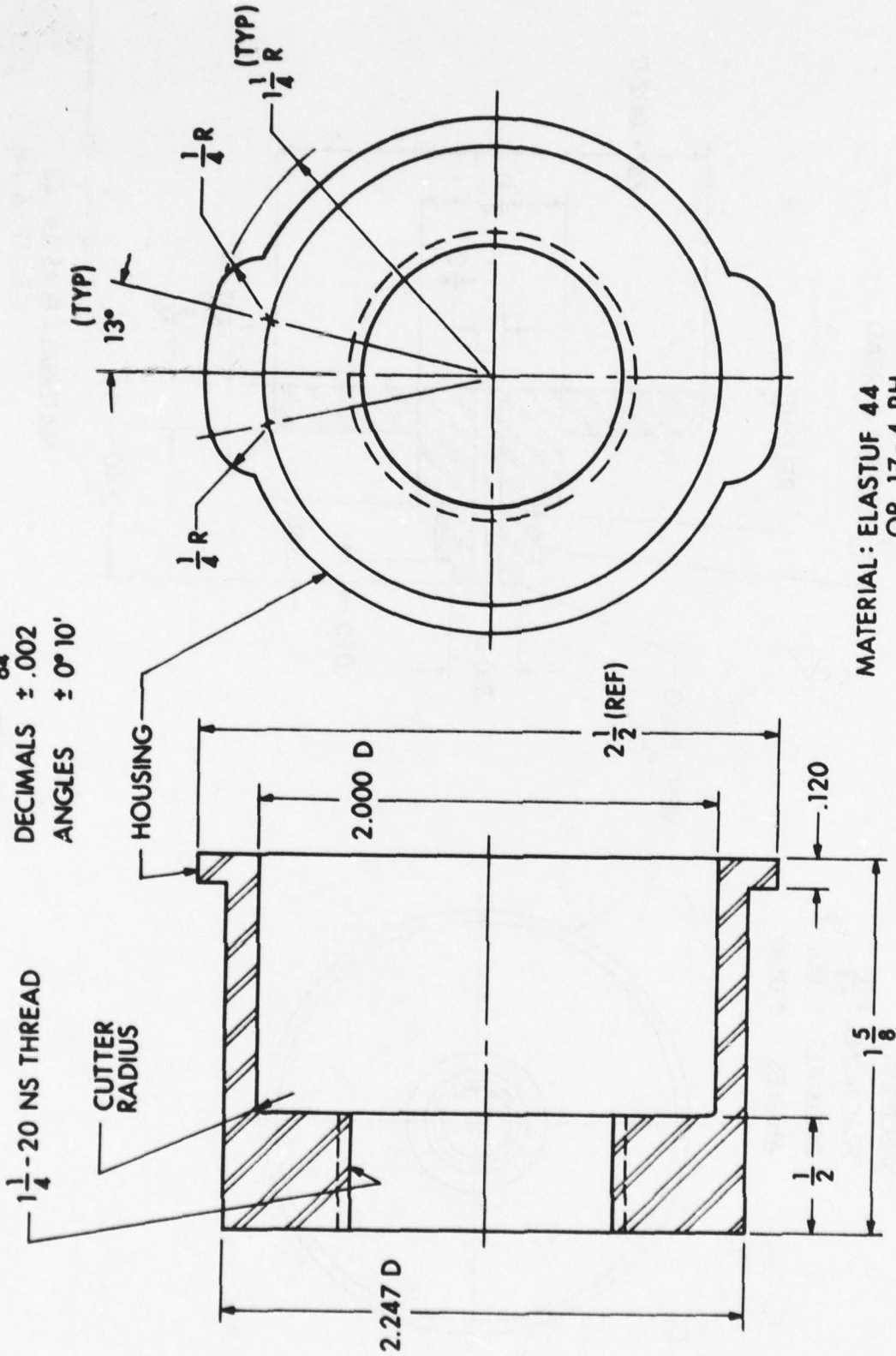

MATERIAL: ELASTUF 44
OR 17-4 PH

Figure 6. Housing

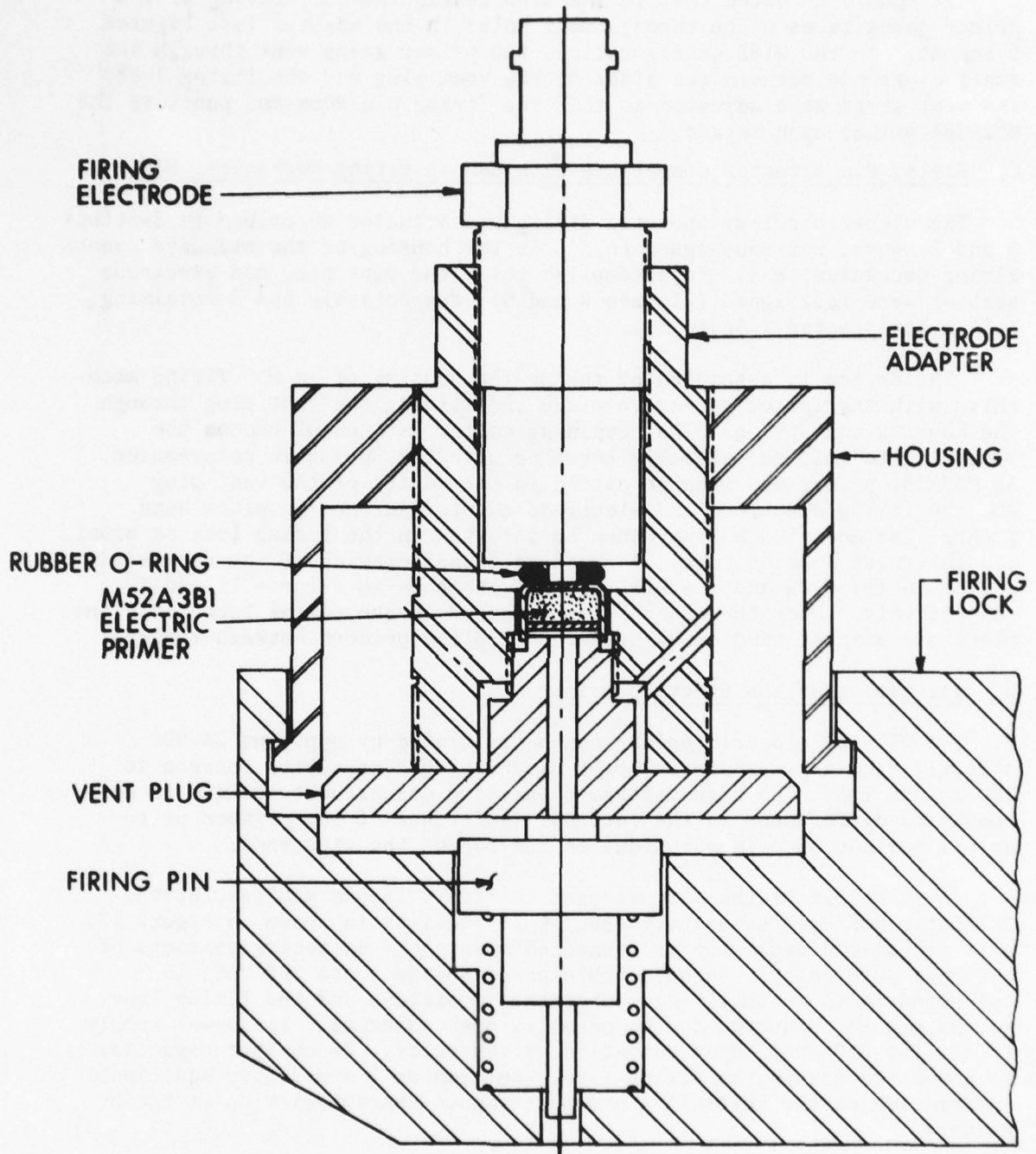

Figure 7. Cross-Section of Assembled Firing Pin Actuator for the M185 Cannon

It should be noted that in the M199 configuration, venting of the primer gases takes place through vent holes in the adapter (see Figures 2 and 3). In the M185 configuration, the primer gases vent through the small clearance between the sides of the vent plug and the firing lock. The vent areas were adjusted so that the firing pin does not puncture the M52A3B1 primer upon impact.

C. Firing Pin Actuator Compatible With Cannon Firing Mechanism, M35

The electric primer-operated firing pin actuator described in Sections A and B above, was redesigned to fit in the housing of the standard cannon firing mechanism, M35. To accomplish this, the vent plug and electrode adapter were redesigned (Figures 8 and 9), respectively and a retaining collar constructed (Figure 10).

The device is assembled by taking the housing of an M35 firing mechanism with the larger spring in place and sliding the vent plug through the housing and spring. The retaining collar is then placed on the vent plug to hold the assembly together with the spring in compression. An M52A3B1 primer may then be placed in the cavity of the vent plug and the firing electrode and electrode adapter screwed in place hand tight. The modified M35 may then be inserted in the firing lock as usual via the twist locking lugs. A cross-sectional drawing of the assembled device in the M199 and the M185 cannons is shown in Figures 11 and 12, respectively. Once the assembly is inserted in the firing lock, only the electrode adapter need be unscrewed to replace primers between firings.

D. Initiation of the Electric Primer

The M52A3B1 electric primer can be initiated by applying 24-VDC directly from a power supply or by discharging a capacitor charged to 100 to 300 VDC. The high voltage capacitive discharge technique is more immune to differences in the internal resistance of the primers or to normal buildup of primer residue on the top of the electrode.

A schematic of the circuit used to fire a 155-mm howitzer at the Ballistic Research Laboratory (BRL) test facility is shown in Figure 13. A 10-microfarad capacitor is connected across the switching contacts of a double pole relay. An adjustable power source (0 to 600 VDC) is connected to the normally-closed contact positions and the firing line to the gun is connected to the normally-open contacts. The power supply is set for 250 VDC. Upon actuation of the relay, the charged capacitor is connected across the firing line. References 1 and 2 give additional information on the initiation and performance characteristics of these primers.

III. RESULTS AND DISCUSSION

The activation time for the device is less than 1 msec from the application of the firing voltage to the beginning of venting of the percussion primer. A typical example of an experimentally measured

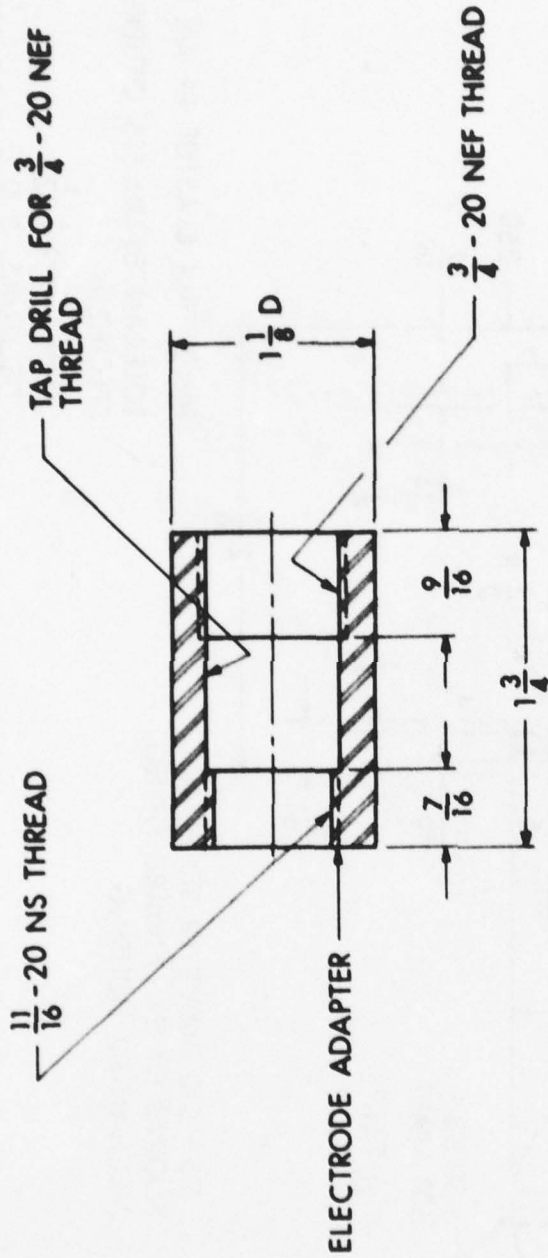

MATERIAL: ELASTUF 44
 OR 17-4 PH

TOLERANCES UNLESS OTHERWISE
 SPECIFIED:

FRACTIONS $\pm \frac{1}{64}$

DECIMALS $\pm .002$

ANGLES $\pm 0^{\circ} 10'$

Figure 9. Electrode Adapter for M35 Replacement

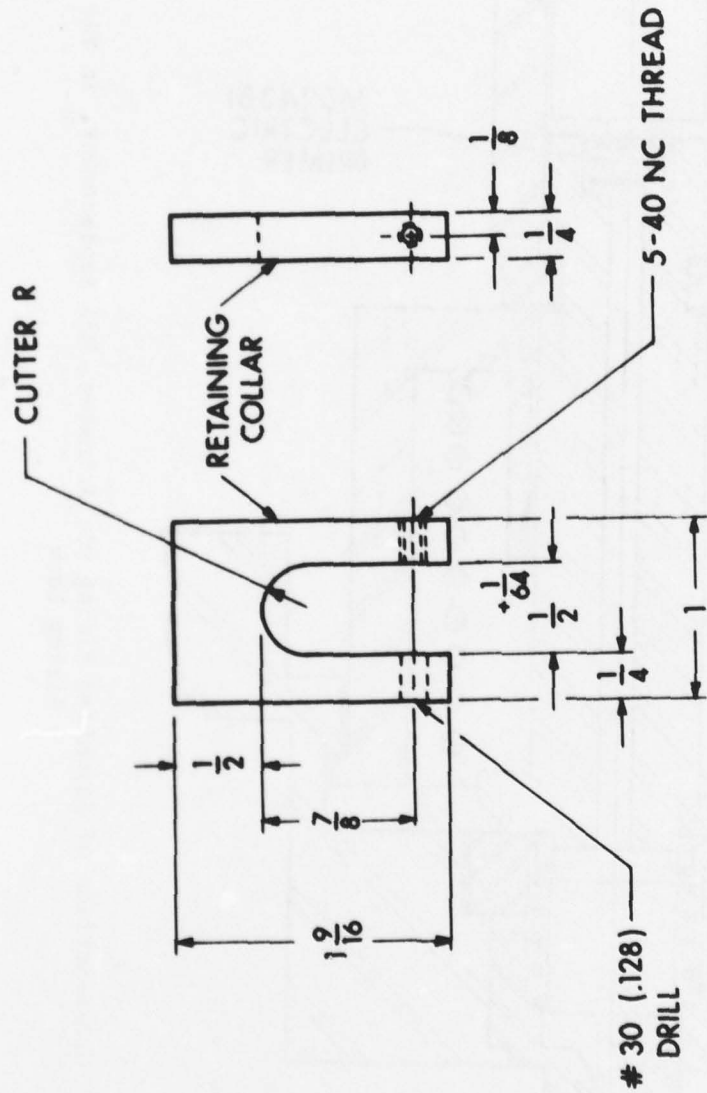

TOLERANCES UNLESS OTHERWISE SPECIFIED:

FRACTIONS $\pm \frac{1}{64}$
 DECIMALS $\pm .002$
 ANGLES $\pm 0^{\circ} 10'$

MATERIAL : C R STEEL (C1018)

Figure 10. Retaining Collar for M35 Replacement

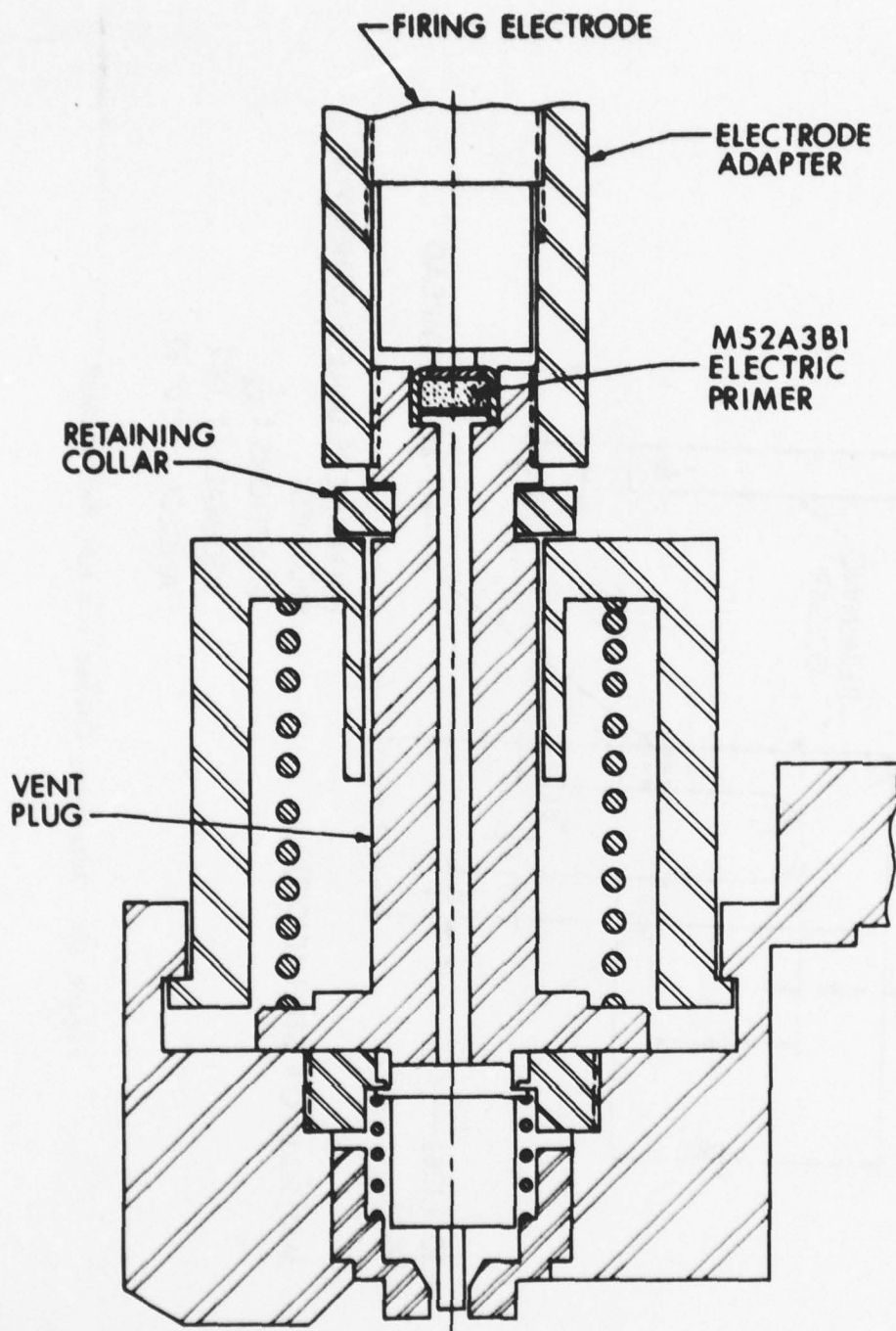

Figure 11. Cross-Section of Assembled Firing Pin Actuator, M35 Replacement, in the M199 Cannon
Firing Lock

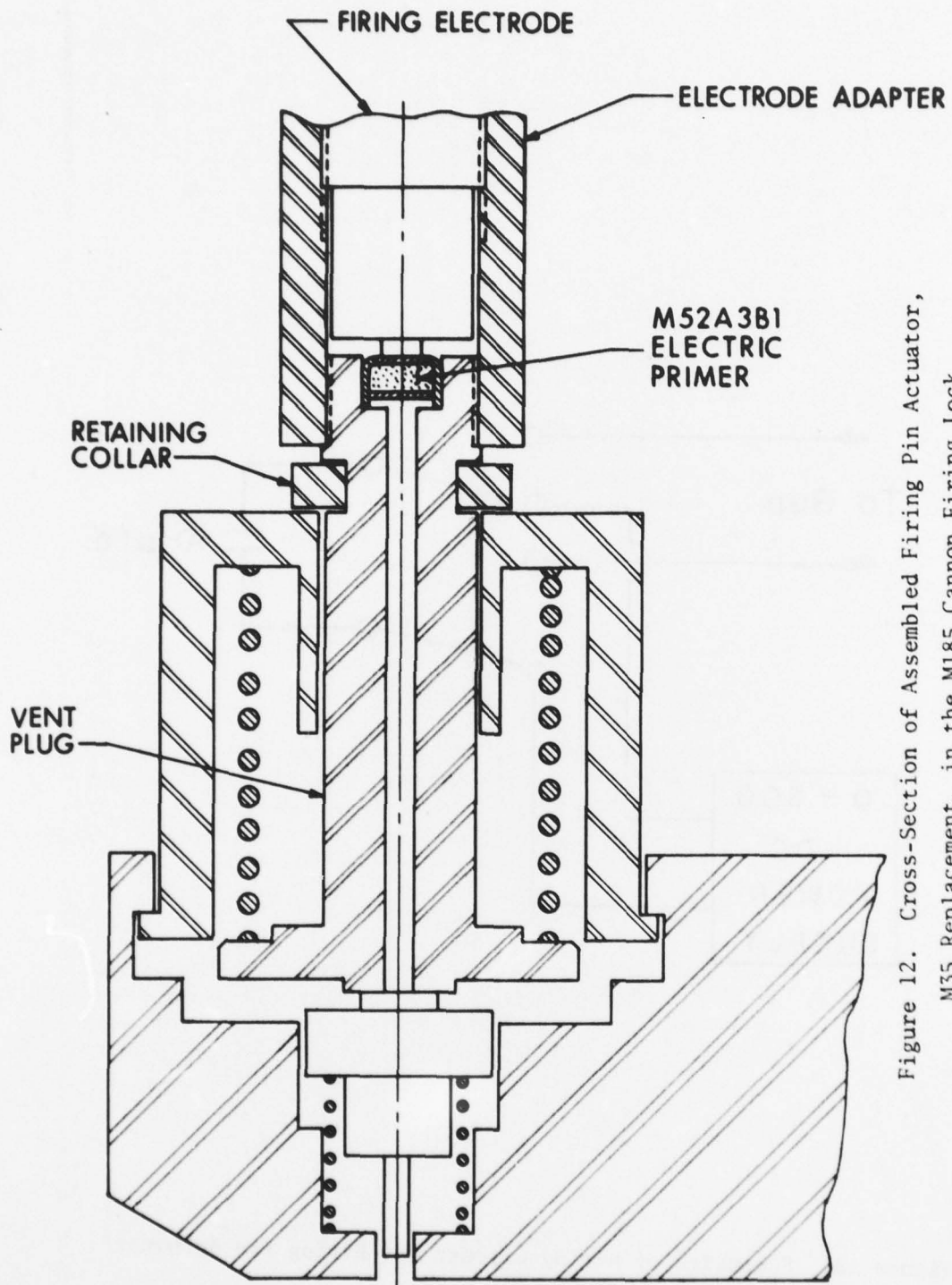

Figure 12. Cross-Section of Assembled Firing Pin Actuator,
M35 Replacement, in the M185 Cannon Firing Lock

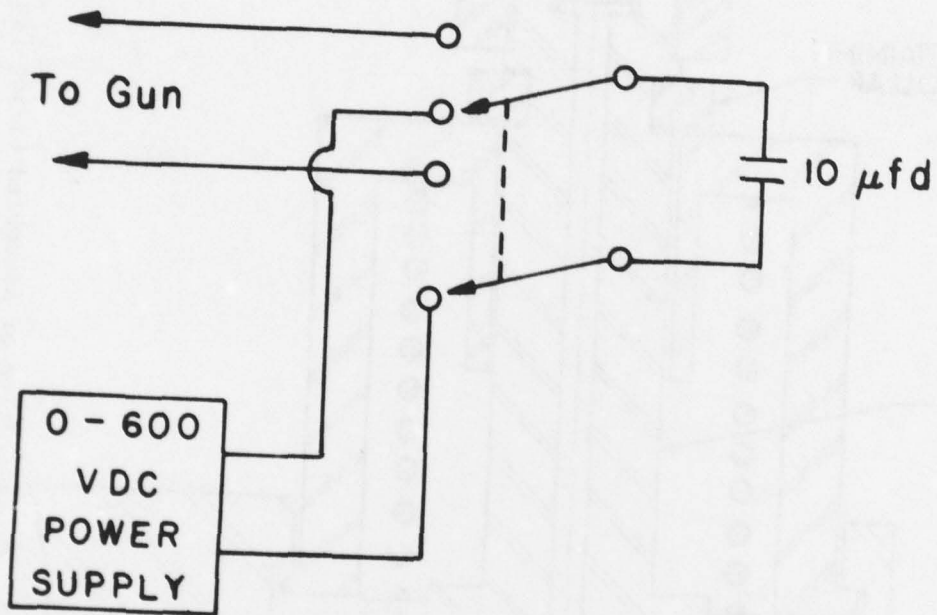

Figure 13. Schematic of Firing Circuit for Firing Pin Actuator

actuation time is shown in Figure 14. One curve indicates the voltage applied to the M52A3B1 primer, and the other curve shows the output of the M82 percussion primer as measured by a pressure transducer located about 12 mm from the exit of the M82 within the spit hole of the M199 spindle. The voltage was applied to the M52A3B1 0.93 msec after the start of the data acquisition for this test. The output of the M82 primer began at 1.58 msec for an action time of 0.65 msec. Therefore, ignition delay times can be accurately measured from the time the firing voltage is applied. These times will be 0.65 msec longer than actual which is negligible in larger guns.

The firing pin actuator has been tested for several hundred rounds at the BRL firing facilities. The gun crews are quite satisfied with its reliability and ease of operation. The Standard Operating Procedure (SOP) for use of the actuator is given in the Appendix.

An important benefit for research applications is that the firing pin actuator allows the percussion primer which is used in the field to be used in a test instead of an electrically actuated substitute. This is important as the substituted electric primer may have a rate of energy delivery (or level) which is different from the percussion primer. This can cloud the results of a test in which the ignition system (percussion primer and igniter) performance is critical. The firing electrode and electrode adapter will be simplified and redesigned as a unit to facilitate its use. This design will be reported separately.

RECOMMENDATION

The firing pin actuator is applicable to all large caliber gun systems which use a standard cannon firing mechanism, M35. These include the 155-mm, 175-mm, and 8-in. gun systems. It is recommended that Modification C be utilized whenever initiation of a percussion primer must be remotely actuated or the time of primer initiation correlated with other events.

ACKNOWLEDGEMENTS

Improvements in the design and operation of the firing pin actuator were facilitated by field tests and many useful comments by Mr. Vernon C. Goetz, and by Dr. Kevin J. White, who also measured the actuation time of the actuator.

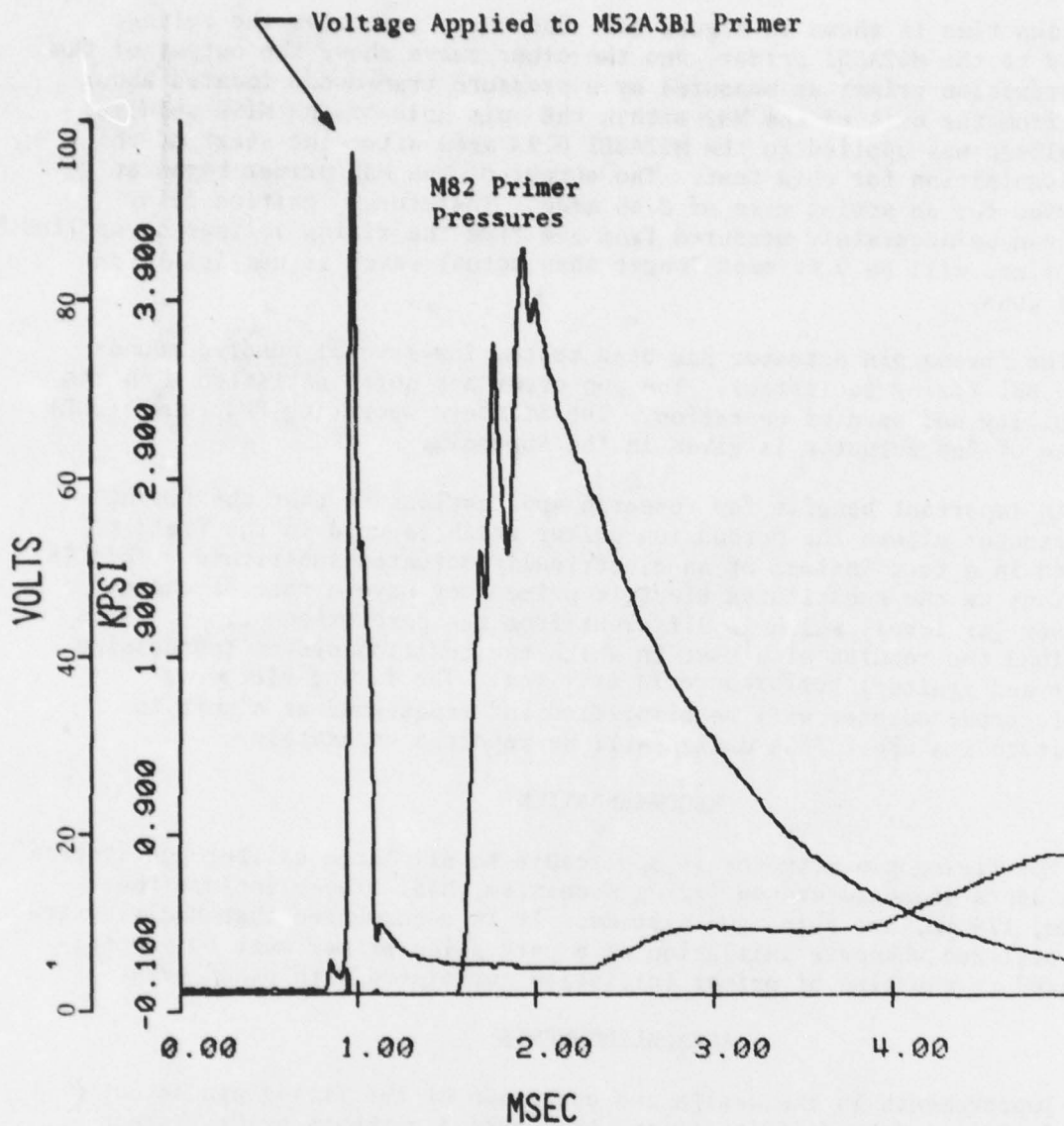

Figure 14. Experimentally Measured Actuation Time: Plot of Electric Primer Initiation Voltage and Output Pressure of M82 Primer (in M199 Spindle) vs. Time

REFERENCES

1. Cronin, R.F., "Investigation of Firing Circuits and Electrical Components for 20-mm Gun, M24A1," US Army Ballistic Research Laboratories Memorandum Report No. 1056, January 1957. (AD #128810)
2. Cronin, R.F., "Investigation of the Electrical Circuit of the 20-mm Gun, M39," US Army Ballistic Research Laboratories Memorandum Report No. 1191, January 1959. (AD #215080)

APPENDIX

STANDARD OPERATING PROCEDURE FOR ELECTRIC PRIMER OPERATED FIRING PIN ACTUATOR

1. Place firing box connector of firing line in the shorting block of the lock-out box.
2. Remove electrode from actuator.
3. Periodically check BNC connector of electrode to assure that there is an open circuit between the central pin and the body of the electrode. (Use VOM or DVM).
4. Place new M52A3B1 primer into the well in the electrode adapter with electrical contact up. Maneuver into recessed holder with fiber or nylon rod and gently press down.
5. Screw electrode into electrode adapter until it is hand tight.
6. Place M35 housing of firing pin actuator in firing lock in safe position.
7. Place firing line connector on BNC connector of electrode.
8. Clear area and return to lock-out box.
9. Check continuity of firing line with DVM or VOM (set to 10 to 100K scale). Resistance should be $\leq 100,000$ ohms and $\geq 10,000$ ohms.

If either condition is not met:

- (a) Too large a resistance indicates a poor electrode/primer contact or broken firing line. Short out firing line; return to gun and remove actuator assembly for inspection.
 - (b) Too small a resistance indicates a short in the primer or in the line. Take same action as in (a) above.
10. Replace short on firing line at lock-out box, return to gun, and move the slide assembly to arm position.
 11. Continue firing procedures as per standard SOP.

In Case of a Misfire: Check the resistance of the firing line from the lock-out box to the electrode.

- (a) If it has changed (an open circuit or a short), this indicates that the M52A3B1 primer has functioned and standard misfire precautions should be followed. (The M52A3B1 gives a clearly audible report when it functions).

- (b) If the resistance has not changed significantly, the primer has not functioned. If the firing voltage can reach the electrode, this indicates a bad primer. Place a short on the firing line. Return to gun and move the slide assembly to the safe position. Remove the actuator assembly for inspection.

- NOTE:
- a) The use of a capacitive discharge firing voltage source eliminates the need for steps 9 and 10 if the integrity of the firing line is intact.
 - b) A DVM or VOM, when set to the proper scale, places a sensing current and voltage on the circuit which is less than or equal to that from a blasting galvanometer.

DISTRIBUTION LIST

<u>No. of Copies</u>	<u>Organization</u>	<u>No. of Copies</u>	<u>Organization</u>
12	Commander Defense Documentation Center ATTN: DDC-DDA Cameron Station Alexandria, VA 22314	1	Commander US Army Missile Materiel Readiness Command ATTN: DRSMI-AOM Redstone Arsenal, AL 35809
1	Commander US Army Materiel Development and Readiness Command ATTN: DRCDMD-ST, N. Klein 5001 Eisenhower Avenue Alexandria, VA 22333	1	Commander US Army Tank Automotive Research & Development Cmd ATTN: DRDTA-UL Warren, MI 48090
1	Commander US Army Aviation Research and Development Command ATTN: DRSAV-E P. O. Box 209 St. Louis, MO 63166	6	Commander US Army Armament Research and Development Command ATTN: DRDAR-LCA-G, D. Downs DRDAR-LCA, R. W. Collett R. C. Reynolds G. Bubb DRDAR-TSS (2 cys) Dover, NJ 07801
1	Director US Army Air Mobility Research and Development Laboratory Ames Research Center Moffett Field, CA 94035	5	Commander US Army Armament Research and Development Command ATTN: DRDAR-TSF, L. Goldsmith Mr. J. Riedener Mr. T. Hayes Mr. P. Roumes Mr. R. Nedelka Dover, NJ 07801
1	Commander US Army Electronics Research and Development Command Technical Support Activity ATTN: DELSD-L Fort Monmouth, NJ 07703	6	Commander US Army Armament Research and Development Command ATTN: DRDAR-LCA, H.D.Fair (2cys) DRDAR-LCA-EP, S.B. Bernstein (3 cys) DRDAR-LCU-S-RI, R. Holzworth Dover, NJ 07801
1	Commander US Army Communications Rsch and Development Command ATTN: DRDCO-PPA-SA Fort Monmouth, NJ 07703		
1	Commander US Army Missile Research and Development Command ATTN: DRDMI-R Redstone Arsenal, AL 35809		

DISTRIBUTION LIST

<u>No. of Copies</u>	<u>Organization</u>	<u>No. of Copies</u>	<u>Organization</u>
1	Commander US Army Armament Materiel Readiness Command ATTN: DRSAR-LEP-L, Tech Lib Rock Island, IL 61299	3	Commander US Army Tropic Region Test Ctr ATTN: STETC-TD APO Miami, FL 34004
1	Commander US Army White Sands Missile Range ATTN: STEWS-TE White Sands, NM 88002	2	Product Manager M110E2 Weapon System ATTN: DRCPM-M110E2-TM Mr. S. Smith Mr. B. Walters Rock Island, IL 61299
4	Commander US Army Dugway Proving Ground ATTN: STEDP-MT, Mr. J.W. Dyer Mr. J. Deale Mr. B. Anderson STEDP-MT-T-W, J. Keetch Dugway, UT 84022	2	Project Manager Cannon Artillery Weapons Sys ATTN: DRCPM-CAWS-AM Mr. F. Menke DRCPM-CAWS-TE Mr. Femia Dover, NJ 07801
3	Commander US Army Jefferson Proving Ground ATTN: STEJP-MT V. W. Gudkese R. A. Yheulon Madison, IN 47250	1	Director US Army TRADOC Systems Analysis Activity ATTN: ATAA-SL, Tech Lib White Sands Missile Range NM 88002
5	Commander US Army Yuma Proving Ground ATTN: STEYP-MT STEYP-MTW, Mr. Taylor STEYP-MTC, W. Phillips Mr. M. J. Gallet Yuma, AZ 85364	1	Commander US Army Field Artillery School Fort Sill, OK 73503
3	Commander US Army Tonopah Test Range ATTN: Div 1173, J. Patrick P. O. Box 871 Tonopah, NV 89049	1	Commander Naval Surface Weapons Center ATTN: Dr. J. East Dahlgren, VA 22448
3	Commander US Army Cold Region Test Ctr ATTN: STECR-TA APO Seattle, WA 98733	1	Calspan Corporation ATTN: Mr. E. Fisher P. O. Box 235 Buffalo, NY 14221

DISTRIBUTION LIST

Aberdeen Proving Ground

Dir, USAMSA

ATTN: Dr. J. Sperrazza
DRXSY-MP, H. Cohen

Cdr, USATECOM

ATTN: DRSTE-SG-H
DRSTE-AD-M
Mr. J. Horton
Mr. A. H. Edwards

Dir, USAMTD

ATTN: STEAP-MT (2 cys)
STEAP-MT-A, W. Rieden
STEAP-MT-G, K. Balliet
G. Rogers