

AD-A069 110

ARMY ARMAMENT RESEARCH AND DEVELOPMENT COMMAND ABERD--ETC F/G 19/1
YAWSONDE FLIGHT OF 155MM NON-CONICAL BOATTAIL PROJECTILE- B CON--ETC(U)
MAR 79 A S PLATOU
ARBRL-MR-02908

SBIE-AD-E430 235

NL

UNCLASSIFIED

| OF |
AD
A069 110

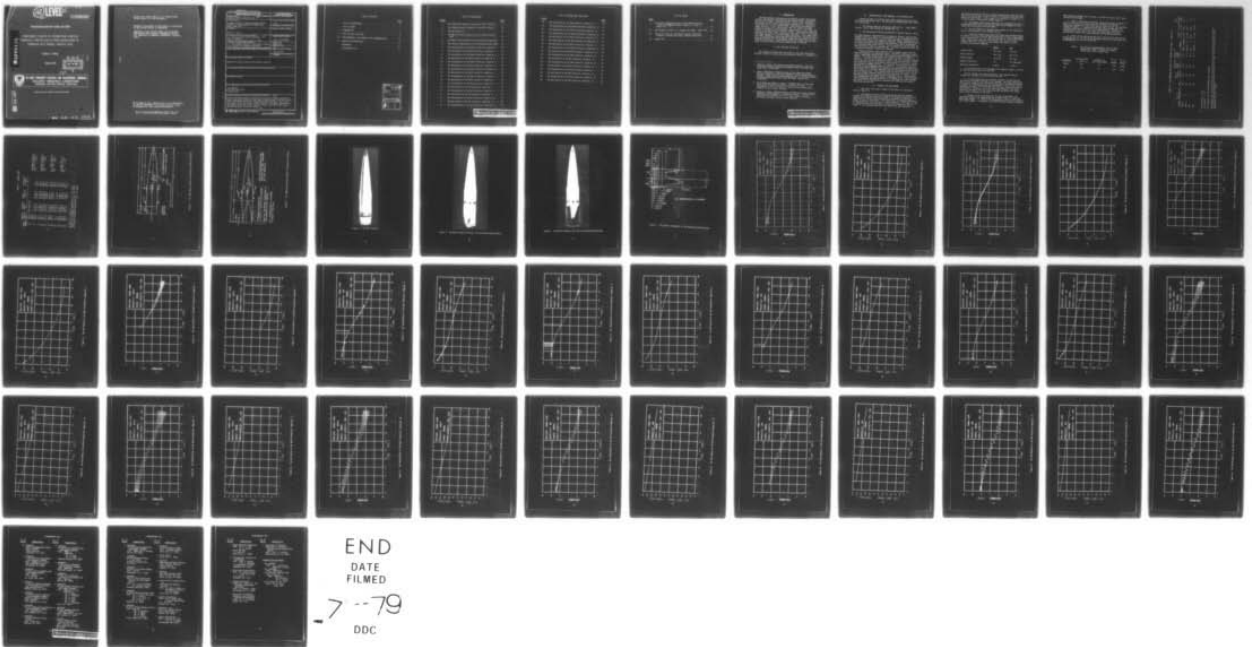

END
DATE
FILMED

7-79
DDC

12 LEVEL III
NA

AD-E430 235

MEMORANDUM REPORT ARBRL-MR-02908

YAWSONDE FLIGHTS OF 155MM NON-CONICAL
BOATTAIL PROJECTILE-B CONFIGURATIONS AT
TONOPAH TEST RANGE--MARCH 1978

AD A069110

Anders S. Platou

March 1979

DDC
RECEIVED
MAY 30 1979
B



US ARMY ARMAMENT RESEARCH AND DEVELOPMENT COMMAND
BALLISTIC RESEARCH LABORATORY
ABERDEEN PROVING GROUND, MARYLAND

Approved for public release; distribution unlimited.

DDC FILE COPY

05 09 002

79
Destroy this report when it is no longer needed.
Do not return it to the originator.

Secondary distribution of this report by originating
or sponsoring activity is prohibited.

Additional copies of this report may be obtained
from the National Technical Information Service,
U.S. Department of Commerce, Springfield, Virginia
22161.

The findings in this report are not to be construed as
an official Department of the Army position, unless
so designated by other authorized documents.

*The use of trade names or manufacturers' names in this report
does not constitute indorsement of any commercial product.*

UNCLASSIFIED

SECURITY CLASSIFICATION OF THIS PAGE (When Data Entered)

REPORT DOCUMENTATION PAGE		READ INSTRUCTIONS BEFORE COMPLETING FORM
1. REPORT NUMBER MEMORANDUM REPORT ARBRL-MR-02908	2. GOVT ACCESSION NO.	3. RECIPIENT'S CATALOG NUMBER
4. TITLE (and Subtitle) YAWSONDE FLIGHTS OF 155MM NON-CONICAL BOATTAIL PROJECTILE-B CONFIGURATIONS AT TONOPAH TEST RANGE--MARCH 1978	5. TYPE OF REPORT & PERIOD COVERED Final	
	6. PERFORMING ORG. REPORT NUMBER	
7. AUTHOR(s) Anders S. Platou	8. CONTRACT OR GRANT NUMBER(s)	
9. PERFORMING ORGANIZATION NAME AND ADDRESS U.S. Army Ballistic Research Laboratory (ATTN: DRDAR-BLL) Aberdeen Proving Ground, Maryland 21005	10. PROGRAM ELEMENT, PROJECT, TASK AREA & WORK UNIT NUMBERS RDT&E 1L161102AH80	
11. CONTROLLING OFFICE NAME AND ADDRESS U.S. Army Armament Research & Development Command U.S. Army Ballistic Research Laboratory (ATTN: DRDAR-BL) Aberdeen Proving Ground, MD 21005	12. REPORT DATE MARCH 1979	
	13. NUMBER OF PAGES 61	
14. MONITORING AGENCY NAME & ADDRESS (if different from Controlling Office)	15. SECURITY CLASS. (of this report) Unclassified	
	15a. DECLASSIFICATION/DOWNGRADING SCHEDULE	
16. DISTRIBUTION STATEMENT (of this Report) Approved for public release, distribution unlimited.		
17. DISTRIBUTION STATEMENT (of the abstract entered in Block 20, if different from Report)		
18. SUPPLEMENTARY NOTES		
19. KEY WORDS (Continue on reverse side if necessary and identify by block number) Army Ordnance Artillery Projectiles Aeroballistics		
20. ABSTRACT (Continue on reverse side if necessary and identify by block number) (1cb) As part of the BRL program to develop the non-conical boattail projectile, twenty 155mm projectiles were fired from an M185 gun tube on 14 and 16 March 1978 at the Sandia Corporation, Tonopah Test Range, Nevada. This is the third phase of the non-conical boattail program. This report describes the experimental plans and presents the data records and some of the results obtained during the projectile flights.		

DD FORM 1473 1 JAN 73 EDITION OF 1 NOV 65 IS OBSOLETE

UNCLASSIFIED

SECURITY CLASSIFICATION OF THIS PAGE (When Data Entered)

TABLE OF CONTENTS

	<u>Page</u>
LIST OF ILLUSTRATIONS	5
LIST OF TABLES	7
I. INTRODUCTION	9
II. TEST SITE AND FACILITIES	9
III. CONFIGURATIONS, TEST PROGRAM, AND INSTRUMENTATION	10
IV. RESULTS AND CONCLUSIONS	10
REFERENCES	57
DISTRIBUTION LIST	59

ACCESSION for		
NTIS	White Section	<input checked="" type="checkbox"/>
DDC	Buff Section	<input type="checkbox"/>
UNANNOUNCED		<input type="checkbox"/>
JUSTIFICATION _____		
BY _____		
DISTRIBUTION/AVAILABILITY CODES		
Dist.	AVAIL.	and/or SPECIAL
A		

LIST OF ILLUSTRATIONS

<u>Figure</u>		<u>Page</u>
1.	The 155mm Space Research Corporation (SRC) Projectile . .	17
2.	The 155mm Non-Conical Boattail Projectile-B (NCB-B) . . .	18
3.	The SRC Projectile	19
4.	The NCB-B Projectile Without the Discarding Rotating Band	20
5.	The NCB-B Projectile With the Discarding Rotating Band .	21
6.	The Exterior Dimensions of the Discarding Rotating Band .	22
7.	The Yawing Motion of the NCB-B Projectile, Round No. 2 .	23
8.	The Spin Motion of the NCB-B Projectile, Round No. 2 . .	24
9.	The Yawing Motion of the NCB-B Projectile, Round No. 3 .	25
10.	The Spin Motion of the NCB-B Projectile, Round No. 3 . .	26
11.	The Yawing Motion of the NCB-B Projectile, Round No. 5 .	27
12.	The Spin Motion of the NCB-B Projectile, Round No. 5 . .	28
13.	The Yawing Motion of the NCB-B Projectile, Round No. 6 .	29
14.	The Spin Motion of the NCB-B Projectile, Round No. 6 . .	30
15.	The Yawing Motion of the NCB-B Projectile, Round No. 7 .	31
16.	The Spin Motion of the NCB-B Projectile, Round No. 7 . .	32
17.	The Yawing Motion of the SRC Projectile, Round No. 8 . .	33
18.	The Spin Motion of the SRC Projectile, Round No. 8 . . .	34
19.	The Yawing Motion of the SRC Projectile, Round No. 9 . .	35
20.	The Spin Motion of the SRC Projectile, Round No. 9 . . .	36
21.	The Yawing Motion of the SRC Projectile, Round No. 10 . .	37
22.	The Spin Motion of the SRC Projectile, Round No. 10 . . .	38
23.	The Yawing Motion of the SRC Projectile, Round No. 11 . .	39

PRECEDING PAGE BLANK - NOT FILMED

LIST OF ILLUSTRATIONS (Continued)

<u>Figure</u>		<u>Page</u>
24.	The Spin Motion of the SRC Projectile, Round No. 11 . . .	40
25.	The Yawing Motion of the NCB-B Projectile, Round No. 14 .	41
26.	The Spin Motion of the NCB-B Projectile, Round No. 14 . .	42
27.	The Yawing Motion of the NCB-B Projectile, Round No. 16 .	43
28.	The Spin Motion of the NCB-B Projectile, Round No. 16 . .	44
29.	The Yawing Motion of the NCB-B Projectile, Round No. 17 .	45
30.	The Spin Motion of the NCB-B Projectile, Round No. 17 . .	46
31.	The Yawing Motion of the NCB-B Projectile, Round No. 18 .	47
32.	The Spin Motion of the NCB-B Projectile, Round No. 18 . .	48
33.	The Yawing Motion of the SRC Projectile, Round No. 19 . .	49
34.	The Spin Motion of the SRC Projectile, Round No. 19 . . .	50
35.	The Yawing Motion of the SRC Projectile, Round No. 20 . .	51
36.	The Spin Motion of the SRC Projectile, Round No. 20 . . .	52
37.	The Yawing Motion of the SRC Projectile, Round No. 21 . .	53
38.	The Spin Motion of the SRC Projectile, Round No. 21 . . .	54
39.	The Yawing Motion of the SRC Projectile, Round No. 22 . .	55
40.	The Spin Motion of the SRC Projectile, Round No. 22 . . .	56

LIST OF TABLES

<u>Table</u>		<u>Page</u>
I.	The Physical Characteristics of the 155mm Projectiles Fired at Tonopah Test Range, Nevada, on 14 and 16 March 1978	12
II.	The Program for Phase III, Tonopah Test Range - March 1978 .	13
III.	Log of the Phase III Non-Conical Boattail Projectile Flights at Tonopah Test Range, Nevada, March 1978	14
IV.	Impact Data	16

I. INTRODUCTION

The BRL program to develop the non-conical boattail projectile requires the firing of approximately one hundred 155mm projectiles and twenty-two 105mm projectiles under various flight conditions. During each flight various aeroballistic information is recorded for later analysis. So far, thirty 155mm projectiles and twenty-two 105mm projectiles have been fired at APG¹ for charge assessment, mechanical integrity, and aerodynamic characteristics, six 155mm projectiles have been fired at Nicolet, Canada² under minimum stability conditions and fifty 155mm projectiles have been fired at the Tonopah Test Range, Nevada^{3,4} at various flight conditions. This report presents the experimental plans, and the in-flight data records of ten of these projectiles plus ten additional 155mm SRC projectiles used as reference projectiles. These twenty projectile flights are the third phase of the non-conical boattail program flown at Tonopah.

II. TEST SITE AND FACILITIES

The Tonopah Test Range and facilities are the same used during the Phase I and II firings and are described in detail in reference 3.

1. Anders S. Platou, "An Improved Projectile Boattail. Part IV," *Ballistic Research Laboratory Memorandum Report ARBRL-MR-02826*, April 1978. AD B027520L.
2. John H. Whiteside, "Transonic Tests of the 155mm Non-Conical Boattail Projectile A and 8-Inch XM650E4 and EBVP Projectiles at Nicolet, Canada, During January-February 1977," *Ballistic Research Laboratory Memorandum Report ARBRL-MR-02809*, January 1978. AD B027297L.
3. Vural Oskay and Anders S. Platou, "Yawsonde Tests of 155mm M549 Non-Conical Boattail Projectile at Tonopah Test Range," to be published as a *Ballistic Research Laboratory Memorandum Report*, Aberdeen Proving Ground, Maryland.
4. Anders S. Platou, "Yawsonde Flights of 155mm Non-Conical Boattail Projectile Configurations at Tonopah Test Range -- October 1977," *ARBRL-MR-02881*, November 1978, U.S. Army Ballistic Research Laboratory, Aberdeen Proving Ground, Maryland.

III. CONFIGURATIONS, TEST PROGRAM, AND INSTRUMENTATION

During the week of 13 March 1978, twenty 155mm projectiles were fired from an M185 gun tube. Two projectile configurations were flown as listed below.

1. The conical boattail projectile (SRC-E.R.F.B. - MK10, MOD2) Figures 1 and 3 (SRC Drawing No. D214290 Rev. C).
2. The non-conical boattail projectile-B (NCB-B) Figures 2 and 4.

The model physical characteristics are given in Table I, and the test program is given in Table II. Each projectile was instrumented with a yawsonde just prior to the launch so that the angular yawing motion of the projectile during the flight was recorded. Radar tracking was used to obtain projectile trajectories and velocities; impact coordinates were obtained from ground surveys. Muzzle velocities were measured for each projectile using two velocimeters - the NERA (supplied by BRL) and a Doppler Velocimeter (supplied by Tonopah).

The SRC projectiles were launched using standard copper rotating bands and required no preliminary tests. The NCB-B projectiles used a plastic discarding rotating band which required some development of the design. The final design used on the NCB-B projectile is shown in Figure 5. The plastic Euretane was molded onto the triangular boattail with three (one on each triangular surface) aluminum keys used to keep the projectile from sliding axially with respect to the plastic during the projectile ramming process. The exterior of the plastic was then machined to the dimensions shown in Figure 6. At propellant ignition the plastic moves forward with respect to the projectile, breaking into small pieces as it becomes compacted between the projectile and the gun tube rifling grooves. This action brings the projectile spin up to the gun twist value, thereby stabilizing the projectile in flight. After leaving the muzzle the small pieces of plastic fall to the ground and the aluminum keys are thrown away by centrifugal force. The discarding sabot launching technique used here is an expedient for these firings and should not be considered as essential for launching non-conical boattailed projectiles.

IV. RESULTS AND CONCLUSIONS

1. The log of the twenty flights of the Phase III firings is given in Table III.
2. The angular and spin histories obtained from the yawsonde records of the various projectile flights are shown in Figures 7 to 40. Considerable difficulty was experienced in receiving the yawsonde signal on some of the flights. This difficulty is partially attributed to new electronic circuitry used in these yawsondes. On Flights 12 and 22 sufficient data were obtained to warrant data reduction, and on Flight 15, the yawsonde data were lost during the data reduction. A

new reduction starting with the original yawsonde tape recording would have to be carried out in order to obtain the angular motion and spin history of this flight. Since Flight 15 is similar to Flights 14, 16, 17 and 18 there is no need to rework Flight 15.

3. The angular motion data shown that the predominant motion is a precessional limit cycle with any nutational motion damping to zero during the first portion of the flight.

4. On all flights, the yawing motion remains at low levels and there is no indication of an unstable motion.

5. Trajectory computations using the flight data obtained during the Phase III firings show the NCB-B projectile to have a drag coefficient approximately .02 lower than the SRC over the entire Mach number range. Using these drag data and assuming both projectiles are launched from the T-185 gun as shown below, the ranges of these projectiles have been computed.

	<u>NCB-B</u>	<u>SRC</u>
Launch Weight	48.12 kg	45.4 kg
Muzzle Velocity	796.7 m/s	814.3 m/s
Flight Weight	46.31 kg	45.4 kg
Quadrant Elevation	45°	45° (800 mils)
Ballistic Coefficient	2.67818	2.71595

For a standard sea level atmosphere the computed range is 26,970 m for the NCB-B and 26,020 m for the SRC.

For the Tonopah Test Range atmosphere, the computed range is 31,930 m for the NCB-B and 30,750 m for the SRC.

6. At both supersonic and transonic launches, the SRC and the NCB-B have considerably different roll damping. The NCB-B experiences much greater change in spin indicating the twisted triangular boattail is effective in producing large rolling moments. This is also seen by comparing the NCB-A (no bore riders, but the same triangular boattail) spin history, reference 4, with the NCB-B spin history. Both spin histories are nearly the same indicating that the NCB-B bore riders have a minor influence on the spin.

7. Because of the large variation of spin on the NCB-B, the gyroscopic stability is approaching the critical value of 1 near the end of the flight. As a result the yawing motion limit cycle increases just before impact. If required, the boattail twist could be increased

above the gun rifling twist in order to increase the spin (pd/V) near the end of the flight.

8. Impact, deflection, and muzzle velocity are given in Table IV. Table IV also gives the impact data for the NCB-B and the SRC projectiles corrected to the listed muzzle velocities and the resulting dispersion values. It should be noted that these firings were not conducted under ideal conditions for dispersion data, however it is interesting to note that in all cases the dispersion of the SRC projectile is better than those obtained for the NCB-B projectile.

9. On all of the spin plots PHI DOT is the Eulerian spin of the projectile and the spin about the principle body axis at any given time is essentially the average of PHI DOT.

TABLE I. THE PHYSICAL CHARACTERISTICS OF THE 155MM PROJECTILES FIRED AT TONOPAH TEST RANGE, NEVADA, ON 14 AND 16 MARCH 1978

Projectile	Average Weight kg	Average C.G. Cal. Aft of Nose	Av. I_x kg m ²	Av. I_y kg m ²
NCB-B	46.4	3.9	.122	1.695
SRC	45.9	3.9	.144	1.885

TABLE II. THE PROGRAM FOR PHASE III, TONOPAH TEST RANGE - MARCH 1978

Round	No. of Projectiles	Gun	Muzzle Velocity m/sec	Projectile Launch Weight kg	Projectile Flight Weight kg	Charge	Range m	Altitude m	Time of Flight secs
NCB-B	5	155	344	48.0	46.3	M3A1 Z5+85gms	10,180	2680	48
NCB-B	5	155	640	48.0	46.3	XM201E2 Z7	22,138	6784	74
SRC	5	155	344	45.4	45.4	M3A1 Z5	9205	4298	47.5
SRC	5	155	675	45.4	45.4	XM201E2 Z7	22,310	7,078	75

Gun Elevation = 45°
 Gun Azimuth = 147°

All flights will be instrumented with yawsondes.

All flights will require recording of radar position data, breech pressure, muzzle velocity, projectile position (using smear camera) near muzzle, impact data, and meteorological data before and after the flights.

TABLE III. LOG OF THE PHASE III NONCONICAL BOATTAIL PROJECTILE FLIGHTS AT TONOPAH TEST RANGE, NEVADA
MARCH 1978

Date	Round No.	Time (pst) Hours	Round Type	BRL Yawsonde Number	BRL Project Number	Proj Flight Weight kg	Muzzle Velocity		Distance Rear Face of Breech-m	Time of Flight sec	Breech Pressure N/m ²
							NERA (BRL) m/s	Doppler (Tonopah) m/s			
03/14/78	1	1249	Warmer	-	-	43.1	685.2	683.4	1.010	72	-
"	2	1401	NCB-B	1504	4908	46.38	-	639.5	1.026	73	219
"	3	1417	NCB-B	1505	4906	46.39	643.1	641.3	1.024	74	221
03/15/78	4	1233	Warmer	-	-	43.1	689.2	688.5	1.010	73	-
"	5	1247	NCB-B	1501	4911	46.45	-	639.5	1.029	73	216
"	6	1301	NCB-B	1509	4917	46.46	639.5	638.3	1.029	73	216
"	7	1314	NCB-B	1510	4910	46.25	647.7	640.1	1.029	74	224
"	8	1327	SRC	1513	4789	45.79	675.7	-	0.978	76	258
"	9	1340	SRC	1515	4788	45.61	676.7	-	0.978	76	250
"	10	1352	SRC	1516	4792	45.52	675.7	674.8	0.978	76	249
"	11	1427	SRC	1520	4786	45.76	673.6	672.7	0.978	76	244
"	12*	1438	SRC	1521	4785	45.79	673.6	672.4	0.978	76	251

* Insufficient Yawsonde Transmission

Gun Location Latitude = 37° 50' 46.65277" N

Longitude = 116° 42' 17.00088" W

Height above means Sea Level = 1630.539M MSL

TABLE III (Continued)

Date	Round No	Time (pst) Hours	Round Type	BRL Yawsonde Number	BRL Projectiile Number	Proj Flight Weight kg	Muzzle NERA (BRL) m/s	Muzzle Velocity Doppler (Tonopah) m/s	Ram Distance of Rear Face of Breech-m	Time of Flight sec	Breech Pressure N/m ²
03/16/78	13	1249	Warmer	-	-	43.1	375.8	375.5	1.009	48	-
"	14	1319	NCB-B	1503	4913	46.25	353.6	353.0	1.019	48	99.6
"	15	1339	NCB-B	1502	4907	46.18	356.0	-	1.016	48	102.0
"	16	1352	NCB-B	1506	4914	46.16	356.0	-	1.032	48	101.0
"	17	1404	NCB-B	1507	4902	46.36	-	-	1.018	48	100.0
"	18	1415	NCB-B	1511	4912	46.70	353.6	-	1.022	48	99.5
"	19	1429	SRC	1512	4787	45.73	362.1	360.9	0.978	48	103.0
"	20	1442	SRC	1514	4791	45.98	360.9	359.7	0.978	48	105.0
"	21	1456	SRC	1517	4790	45.84	361.2	360.3	0.978	48	107.0
"	22*	1508	SRC	1518	4794	45.98	360.9	-	0.978	48	107.0
"	23	1520	SRC	1519	4793	45.76	363.0	-	0.978	48	107.0

*Insufficient Yawsonde Transmission
 Gun Location $\phi = 37^{\circ} 50' 46.65277''N$
 $\lambda = 116^{\circ} 42' 17.00088''W$
 H = 1630.539M MSL

TABLE IV. IMPACT DATA

Round Number	Muzzle Velocity m/sec	Measured Range m	Range* Corrected m	Deflection to Right m
2	639.5	Not Received	-	
3	641.3	" "	-	
5	639.5	" "	-	
6	638.3	22,523.5	23,808.0	419.5
7	640.1	22,797.8	24,019.3	522.0
8	675.7	22,985.3	22,960.8	504.4
9	676.7	22,801.5	22,742.0	449.0
10	675.7	22,872.8	22,848.3	506.2
11	673.6	22,755.8	22,804.8	490.5
12	673.6	22,773.1	22,822.1	501.3
14	353.6	10,133.1	10,357.1	191.6
15	356.0	10,309.4	10,449.4	165.0
16	356.0	10,192.2	10,332.2	182.4
17	-	10,105.5	-	174.7
18	353.6	10,201.0	10,425.0	182.9
19	362.1	10,072.6	9,999.1	208.6
20	360.9	10,004.4	9,972.9	213.4
21	361.2	10,020.5	9,978.5	209.9
22	360.9	9,984.7	9,953.2	203.7
23	363.0	10,074.8	9,969.8	213.0

Av Range 23,913.6m
STD. Dev = 149.4m
P.E. = .42%

Av Range 22,835.6m
STD. Dev = 80.2m
P.E. = .24%

Av. Range 10390.5m
STD. Dev = 54.8m
P.E. = .36%

Av Range 9974.7m
STD. Dev = 16.6m
P.E. = .11%

*Round 6 to 12, Range corrected to $V = 675$ m/sec
Round 14 to 23, Range corrected to $V = 360$ m/sec
All Range corrections made using $\frac{\Delta R}{\Delta V} = 35 \frac{m}{m/sec}$

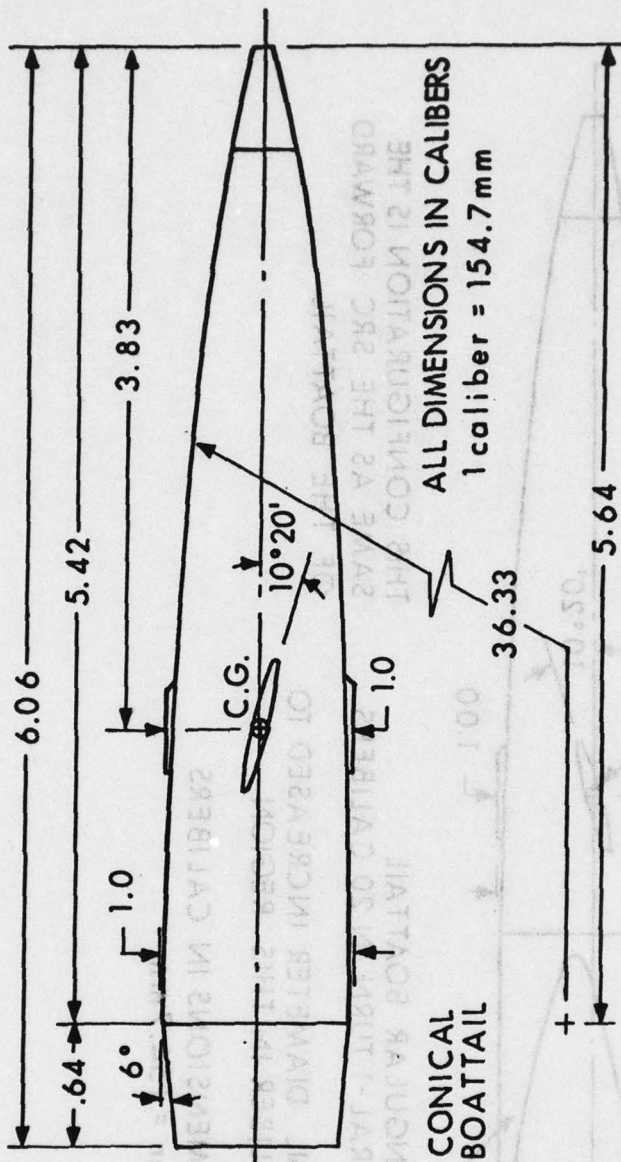
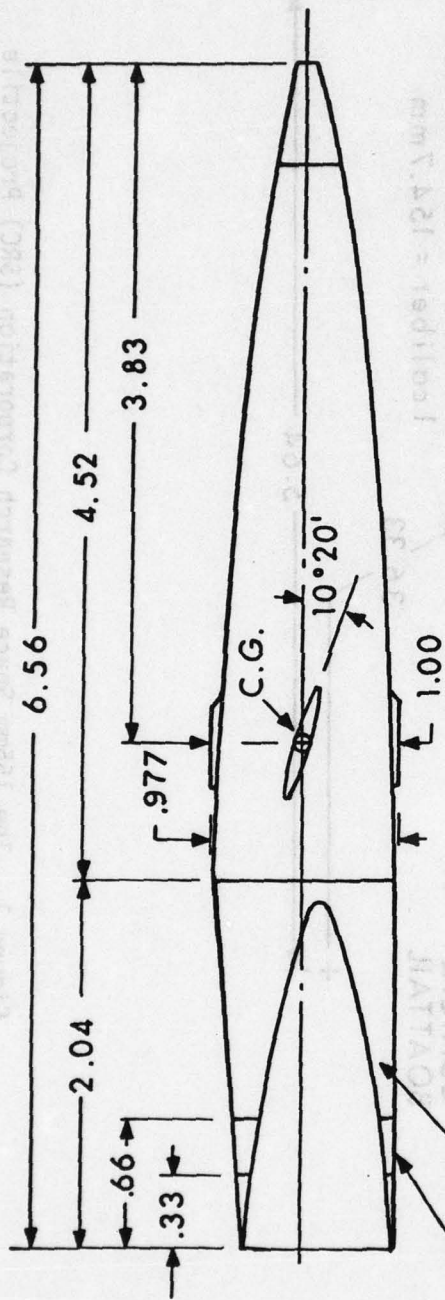

Figure 1. The 155mm Space Research Corporation (SRC) Projectile



7° TRIANGULAR BOATTAIL
 R.H. SPIRAL-1 TURN IN 20 CALIBERS
 BOATTAIL DIAMETER INCREASED TO
 1.00 CALIBER IN THIS REGION
 ALL DIMENSIONS IN CALIBERS
 1 caliber = 154.7 mm

THIS CONFIGURATION IS THE
 SAME AS THE SRC FORWARD
 OF THE BOATTAIL

Figure 2. The 155mm Non-Conical Boattail Projectile B (NCB-B)

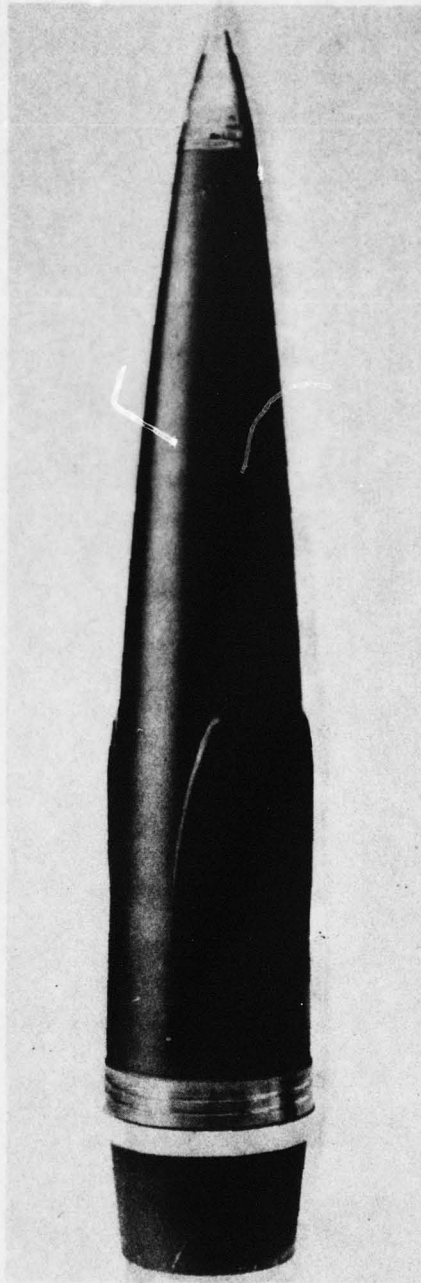

Figure 3. The SRC Projectile

Figure 4. The HCB-B Projectile Without the Dissolving Rotating Band

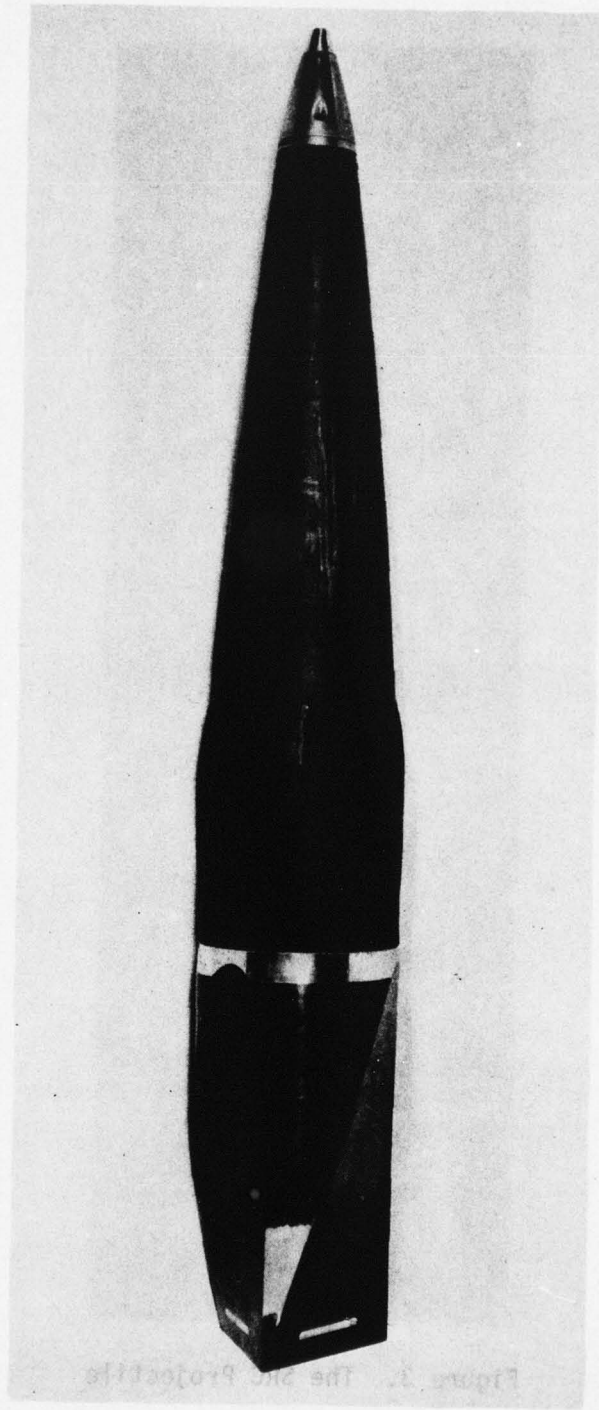

Figure 4. The NCB-B Projectile Without the Discarding Rotating Band

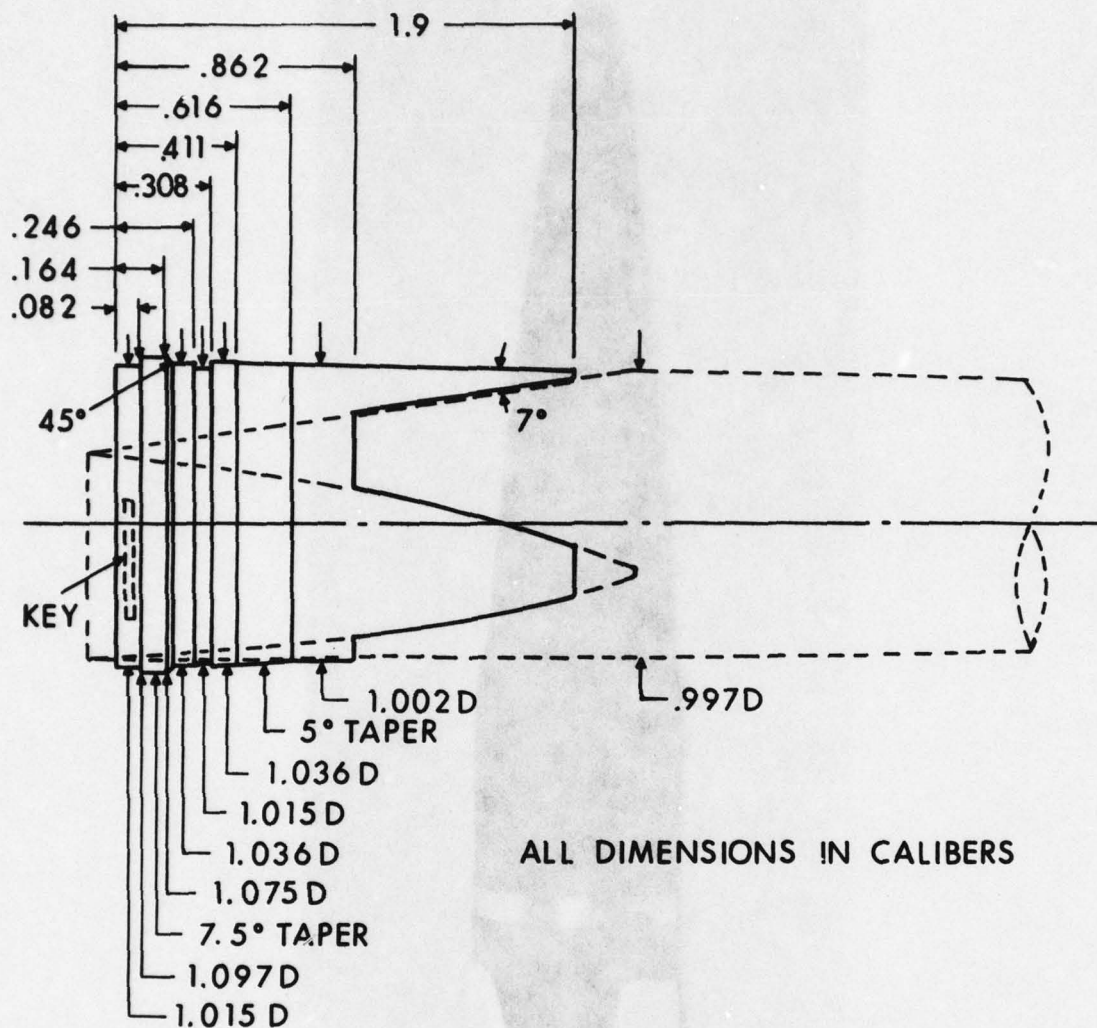

Figure 6. The Exterior Dimensions of the Discarding Rotating Band

Figure 8 The yaw motion of the NCB-B projectile, Round No. 2

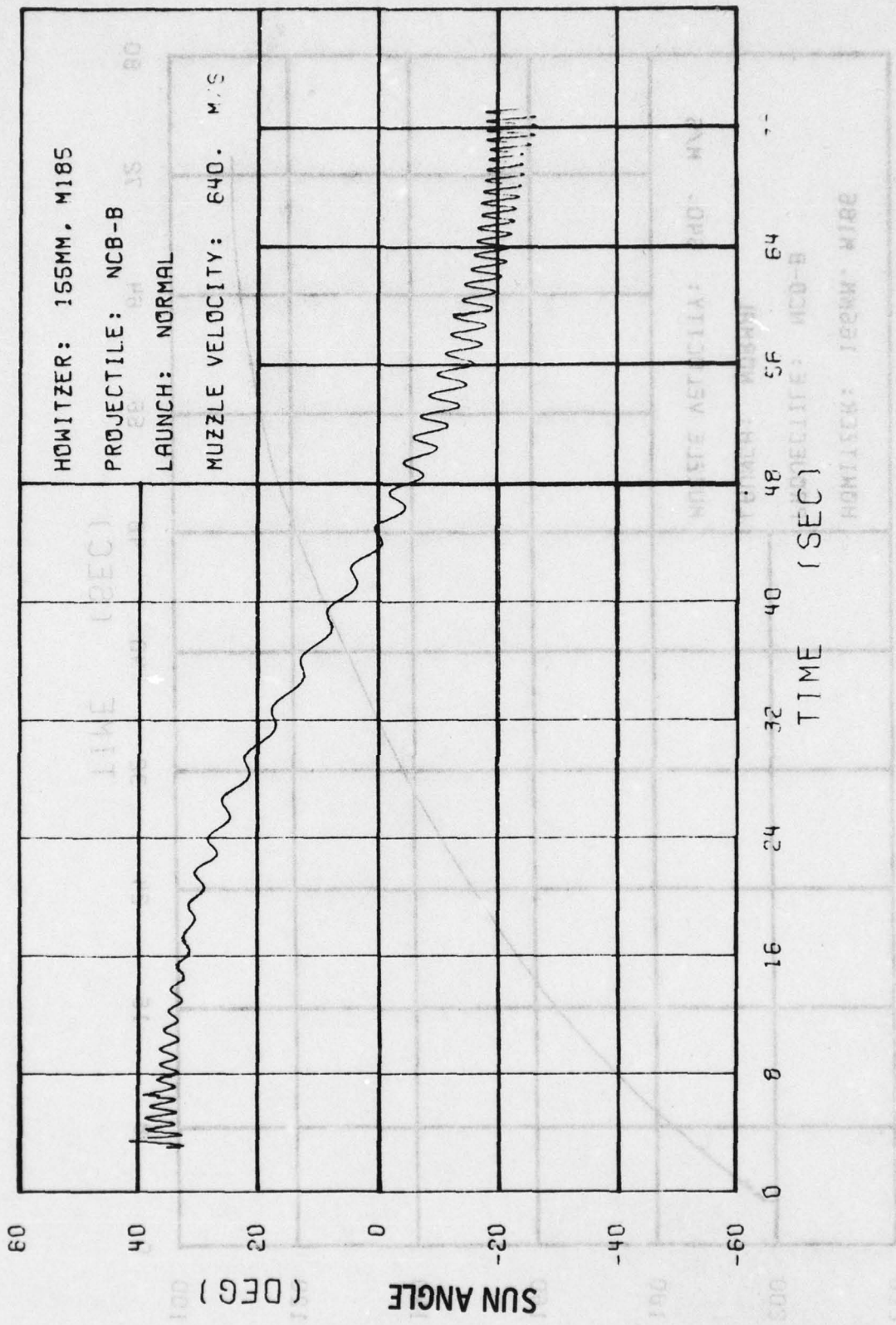

Figure 7. The Yawing Motion of the NCB-B Projectile, Round No. 2

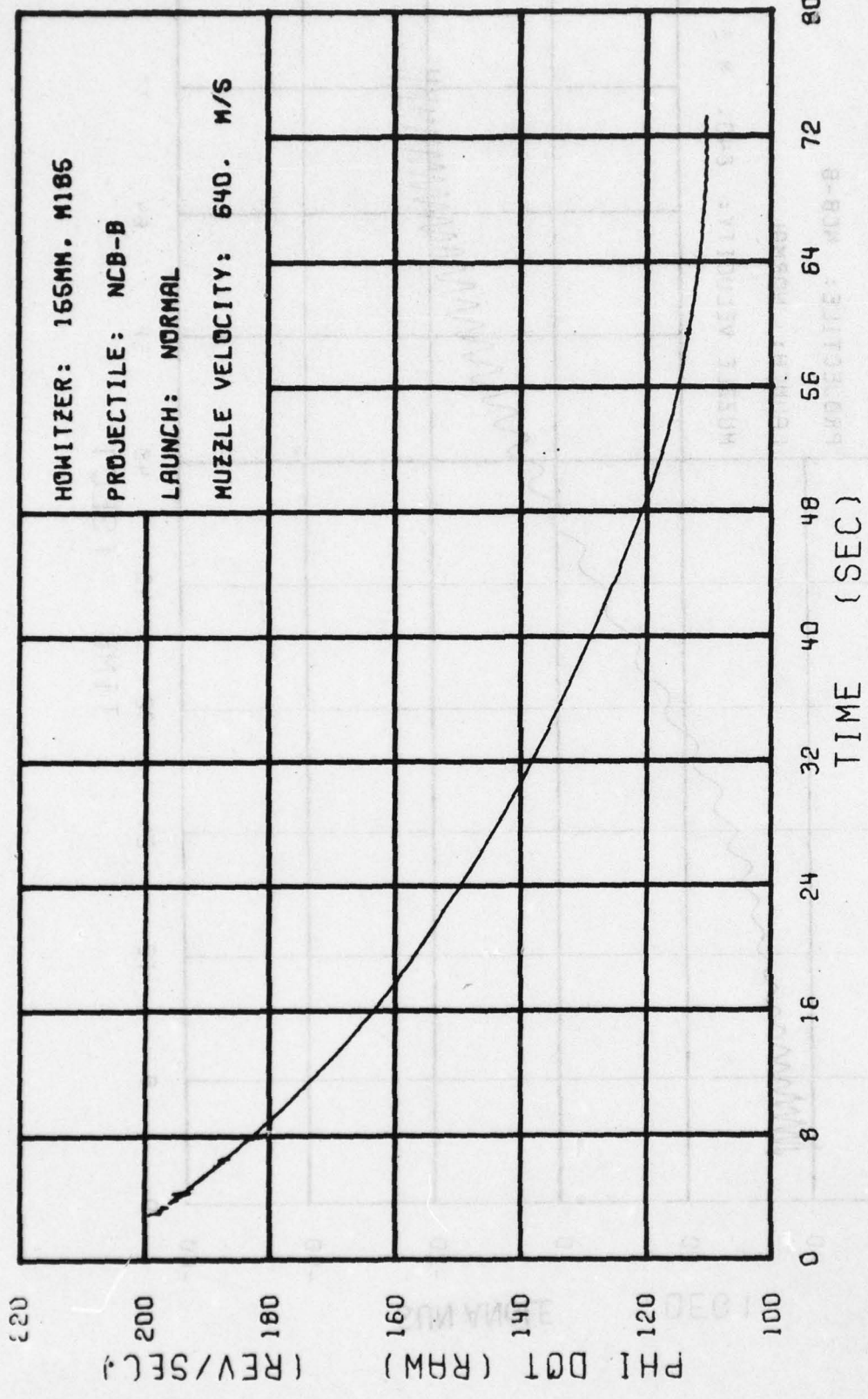

Figure 8. The Spin Motion of the NCB-B Projectile, Round No. 2

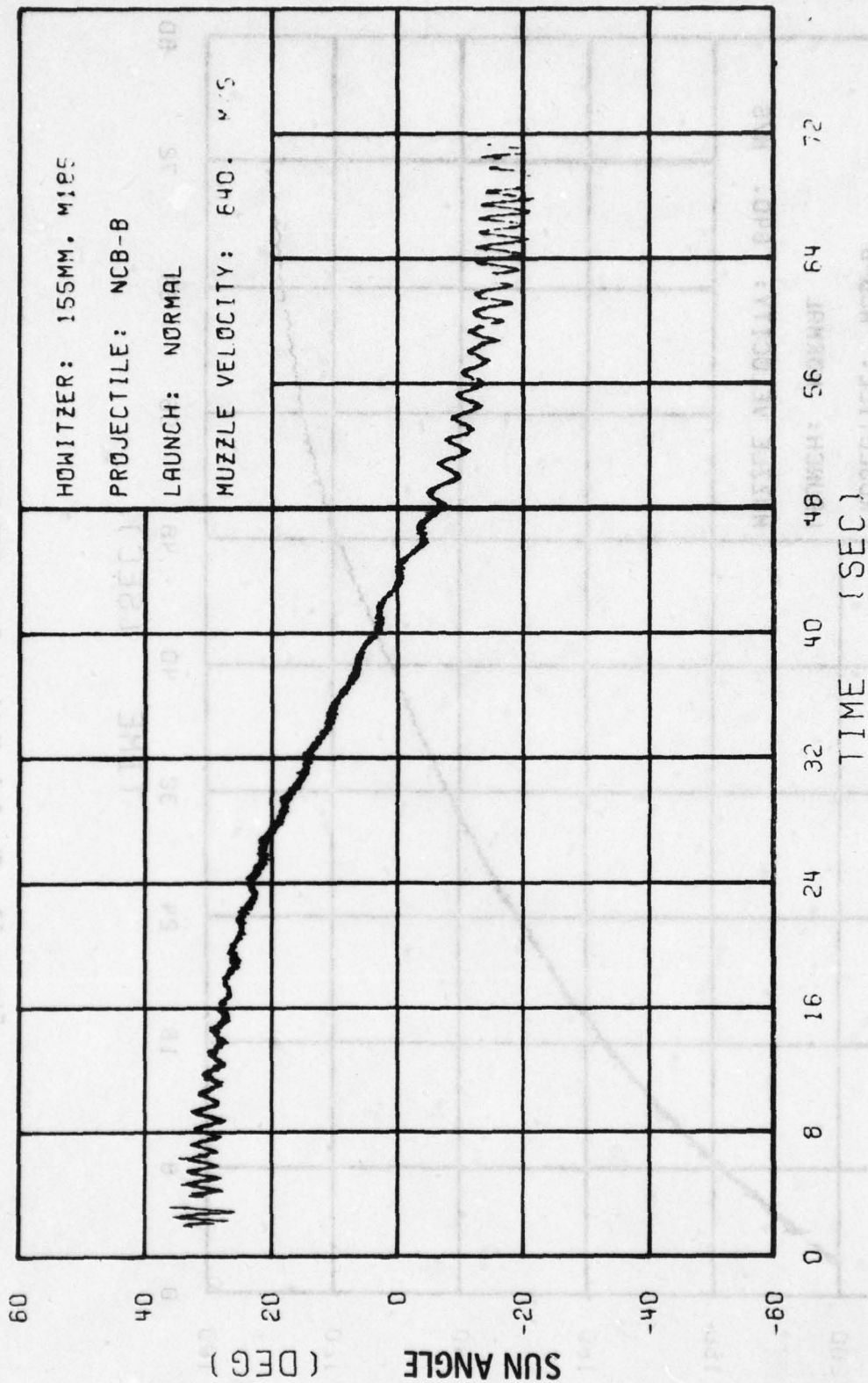

Figure 9. The Yawing Motion of the NCB-B Projectile, Round No. 3

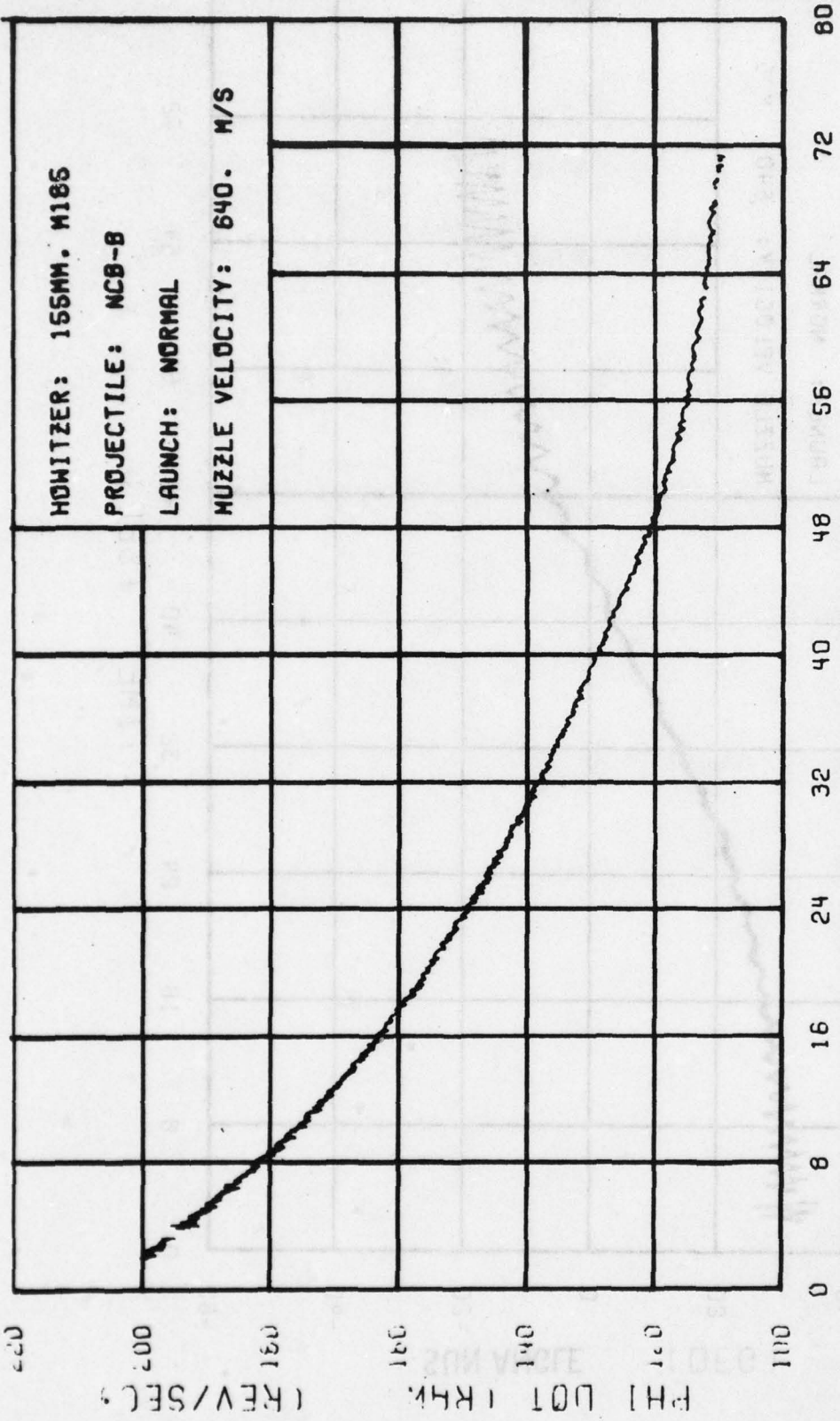

Figure 10. The Spin Motion of the NCB-B Projectile, Round No. 3

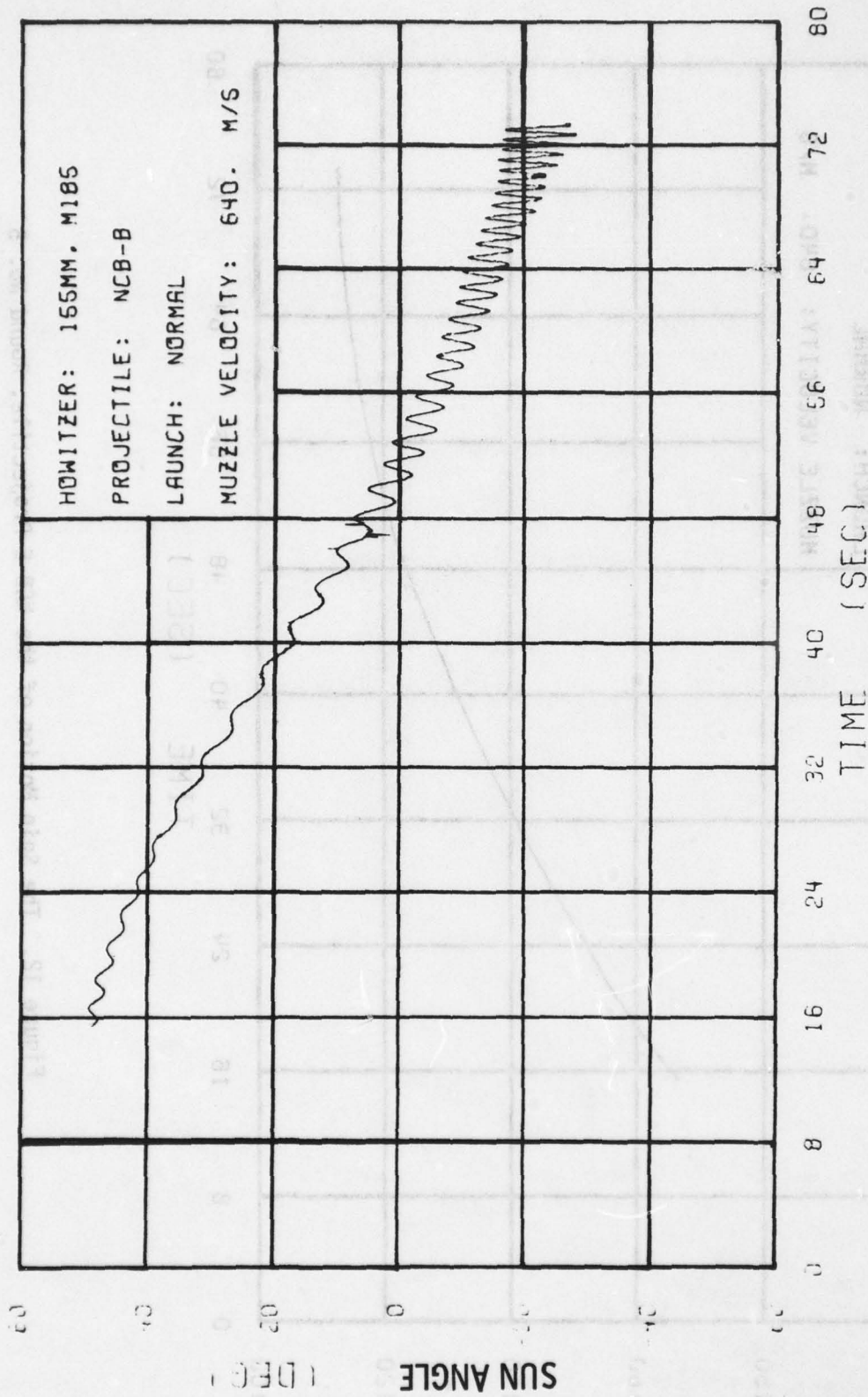

Figure 11. The Yawing Motion of the NCB-B Projectile, Round No. 5

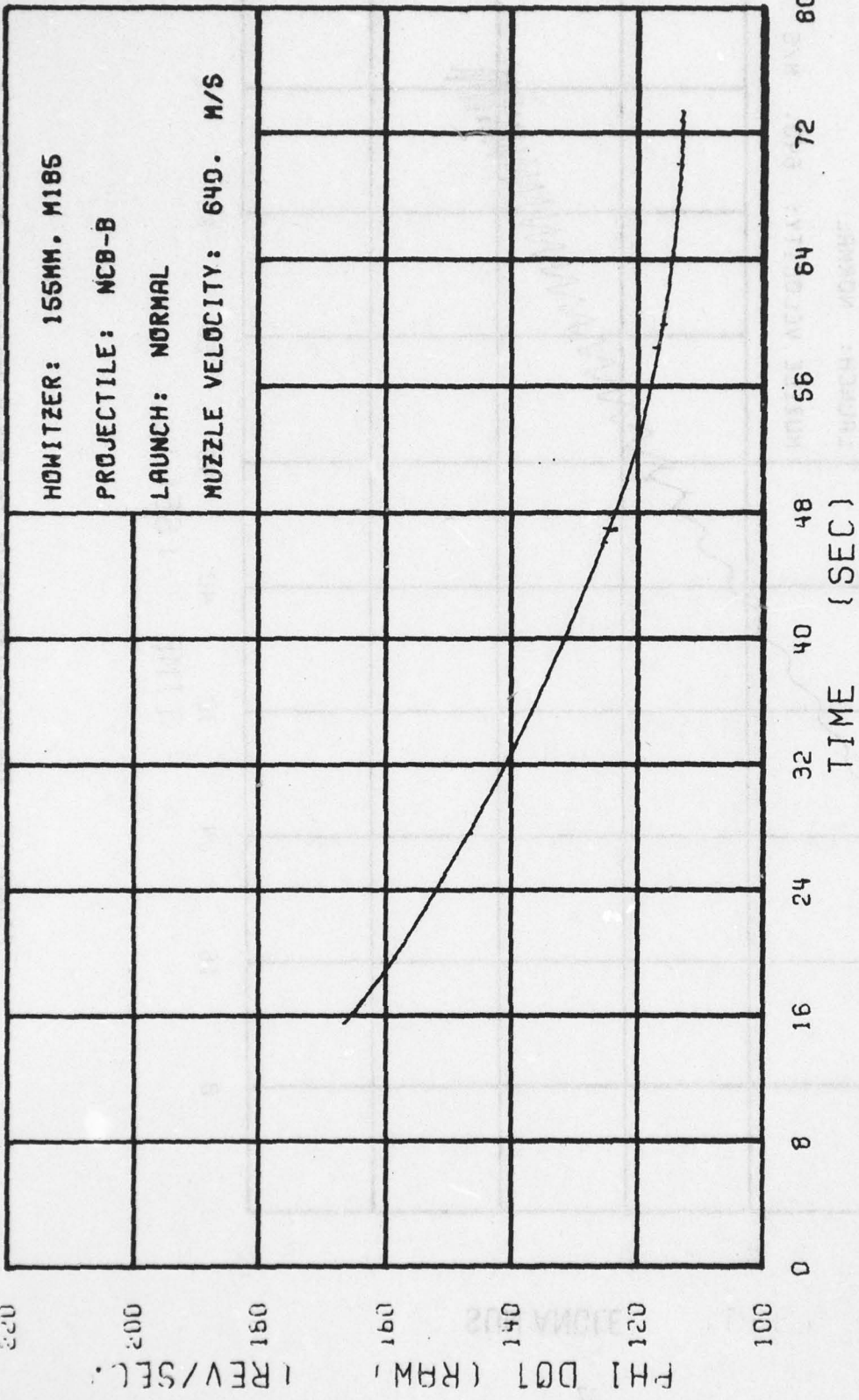

Figure 12. The Spin Motion of the NCB-B Projectile, Round No. 5

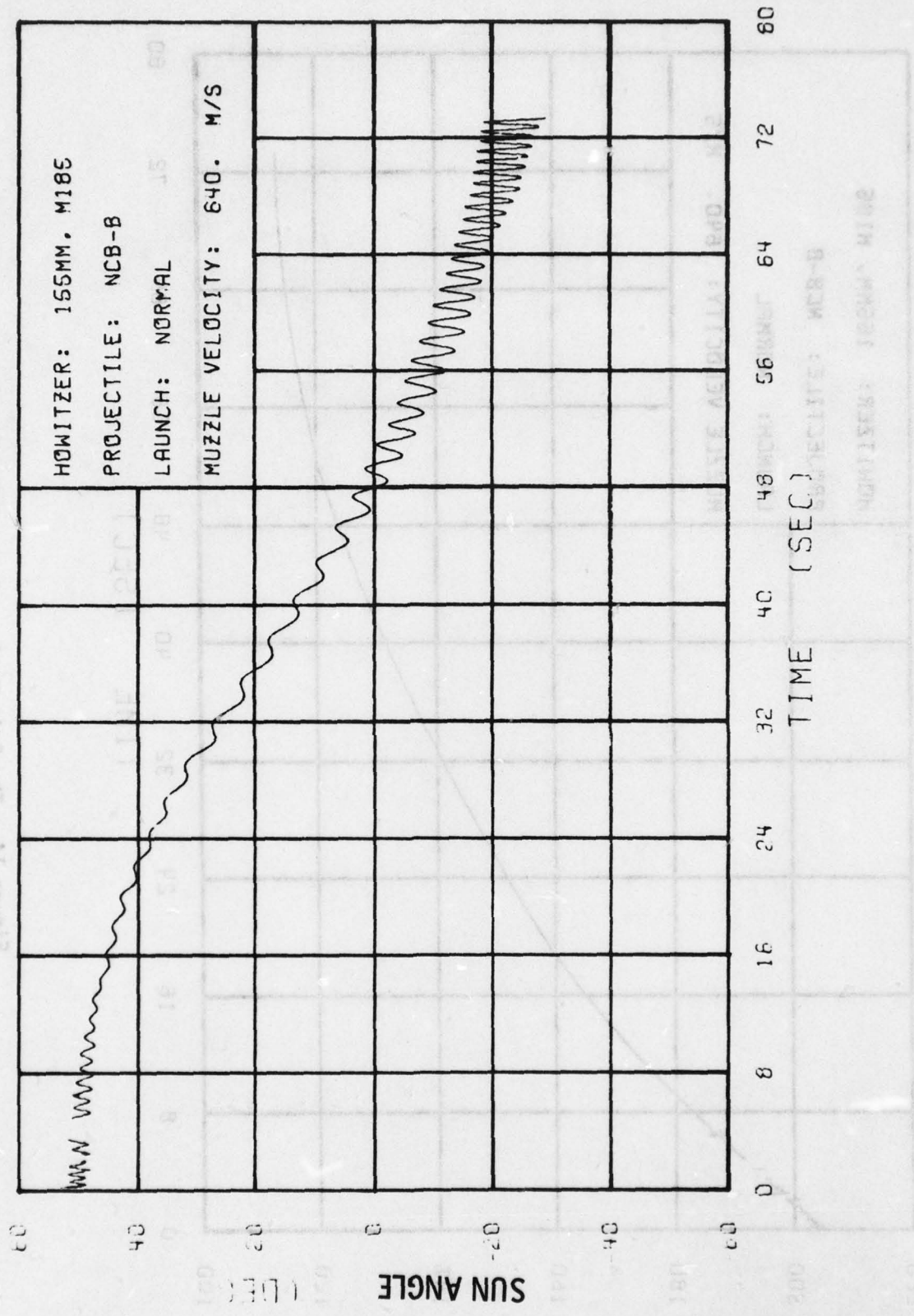

Figure 13. The Yawing Motion of the NCB-B Projectile, Round No. 6

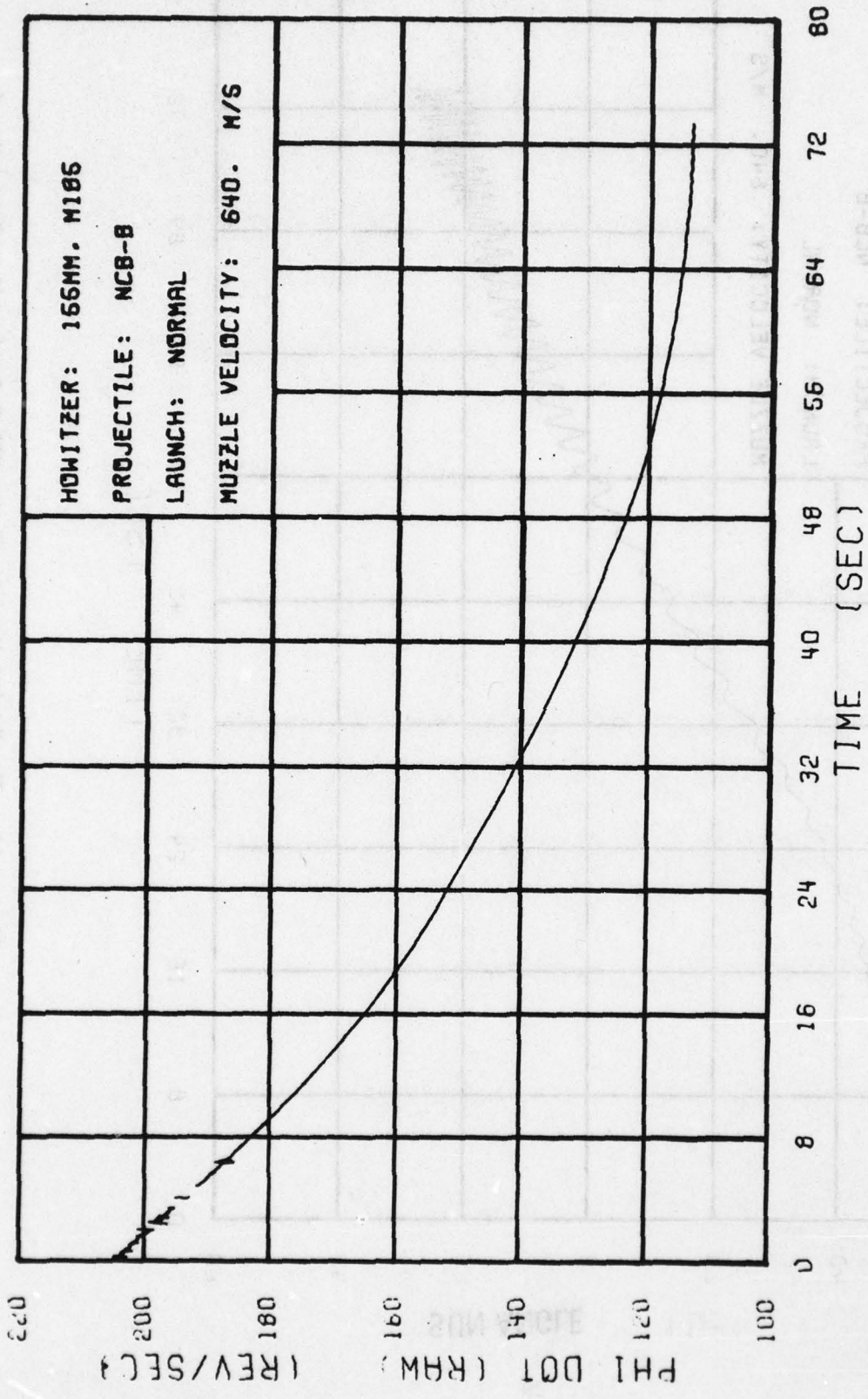

Figure 14. The Spin Motion of the NCB-B Projectile, Round No. 6

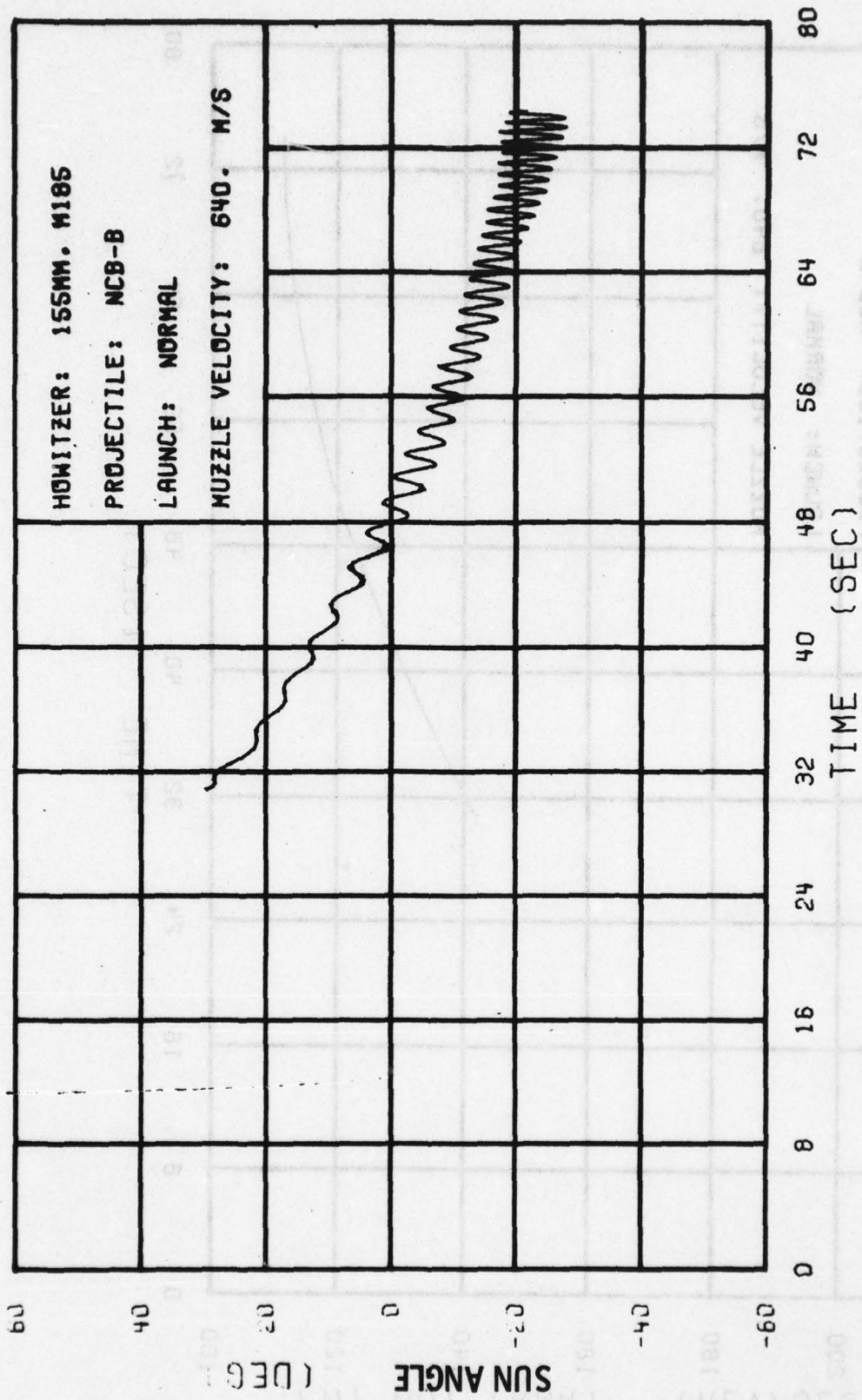

Figure 15. The Yawing Motion of the NCB-B Projectile, Round No. 7

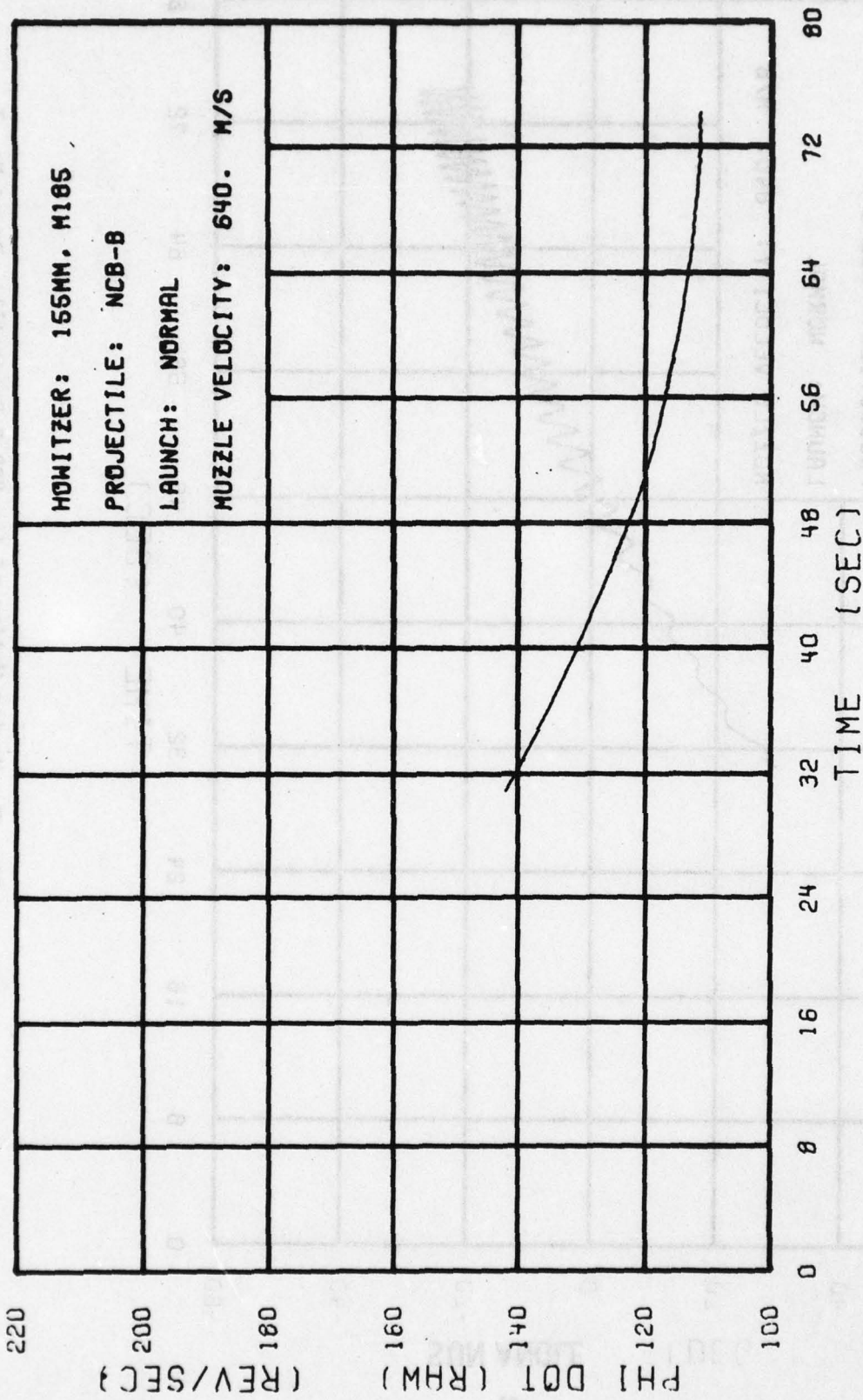

Figure 16. The Spin Motion of the NCB-B Projectile, Round No. 7

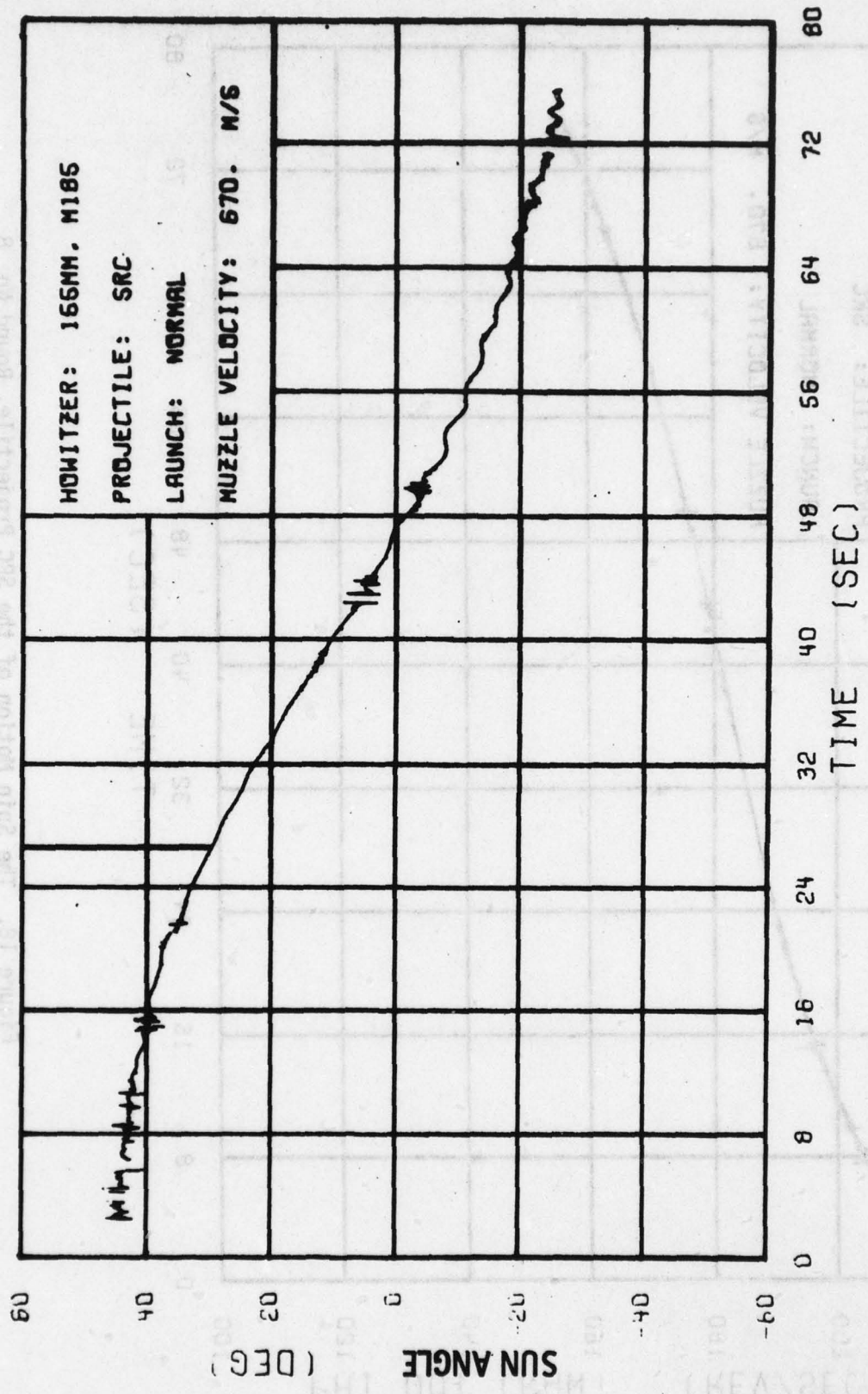

Figure 17. The Yawing Motion of the SRC Projectile, Round No. 8

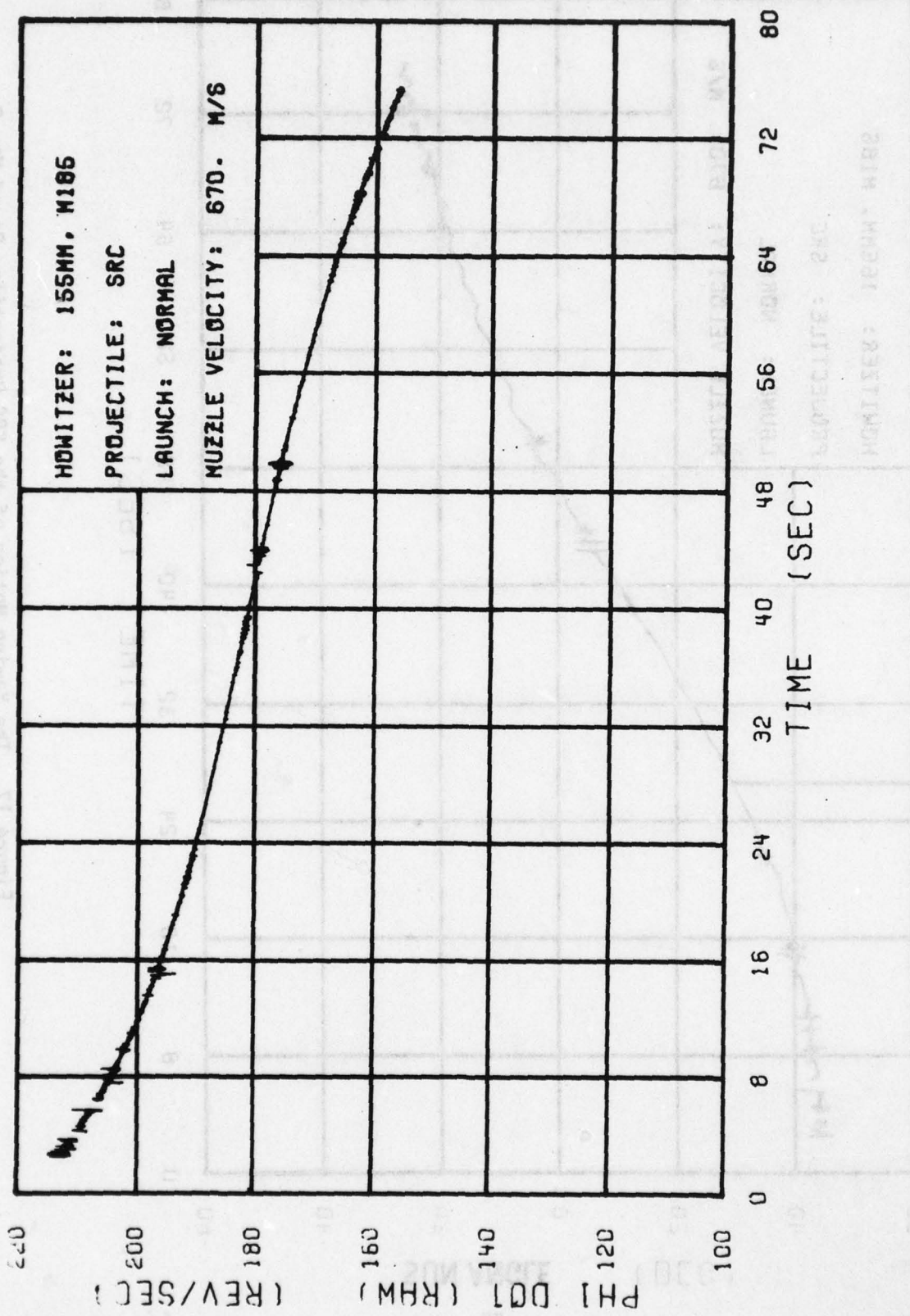

Figure 18. The Spin Motion of the SRC Projectile, Round No. 8

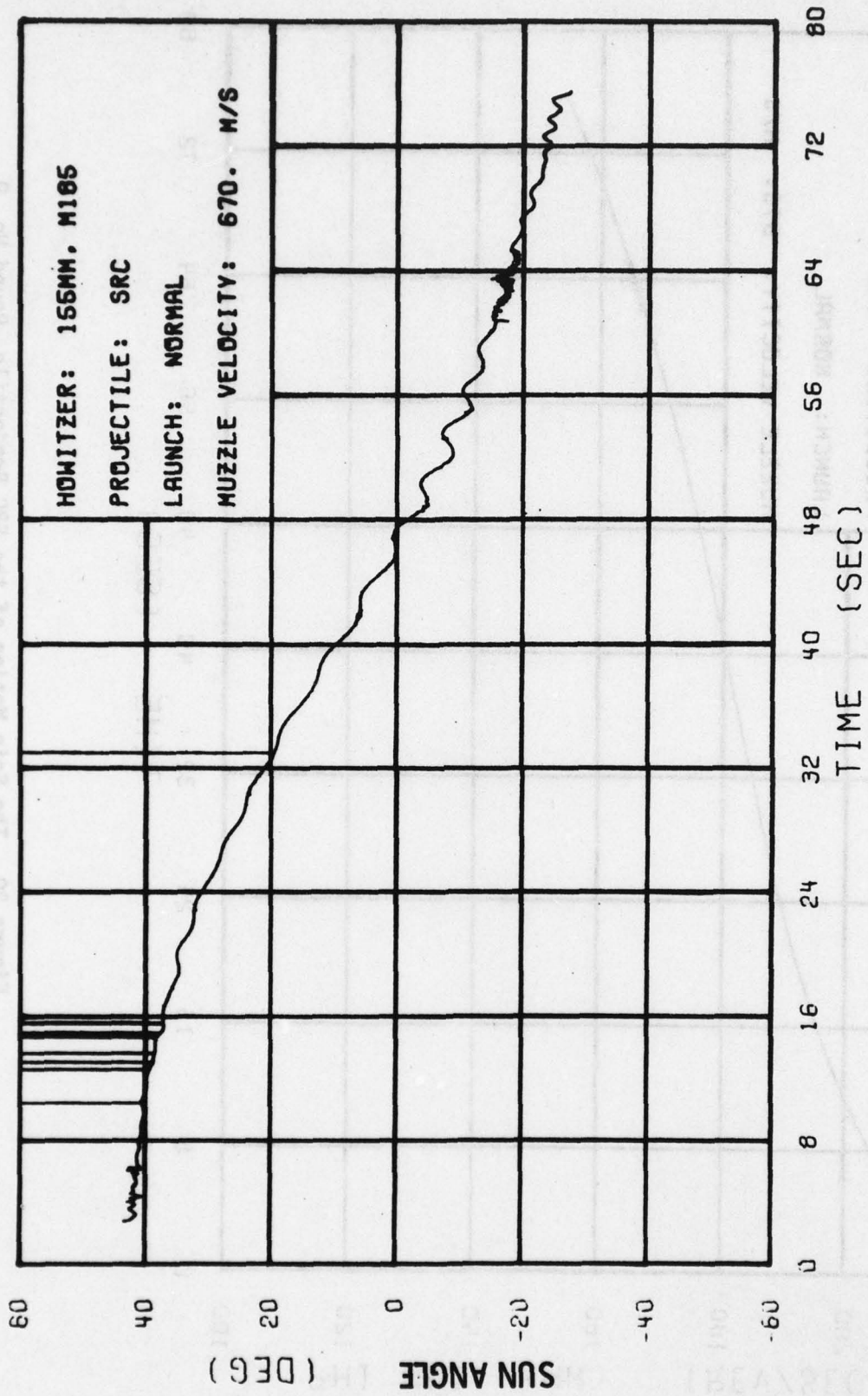

Figure 19. The Yawing Motion of the SRC Projectile, Round No. 9

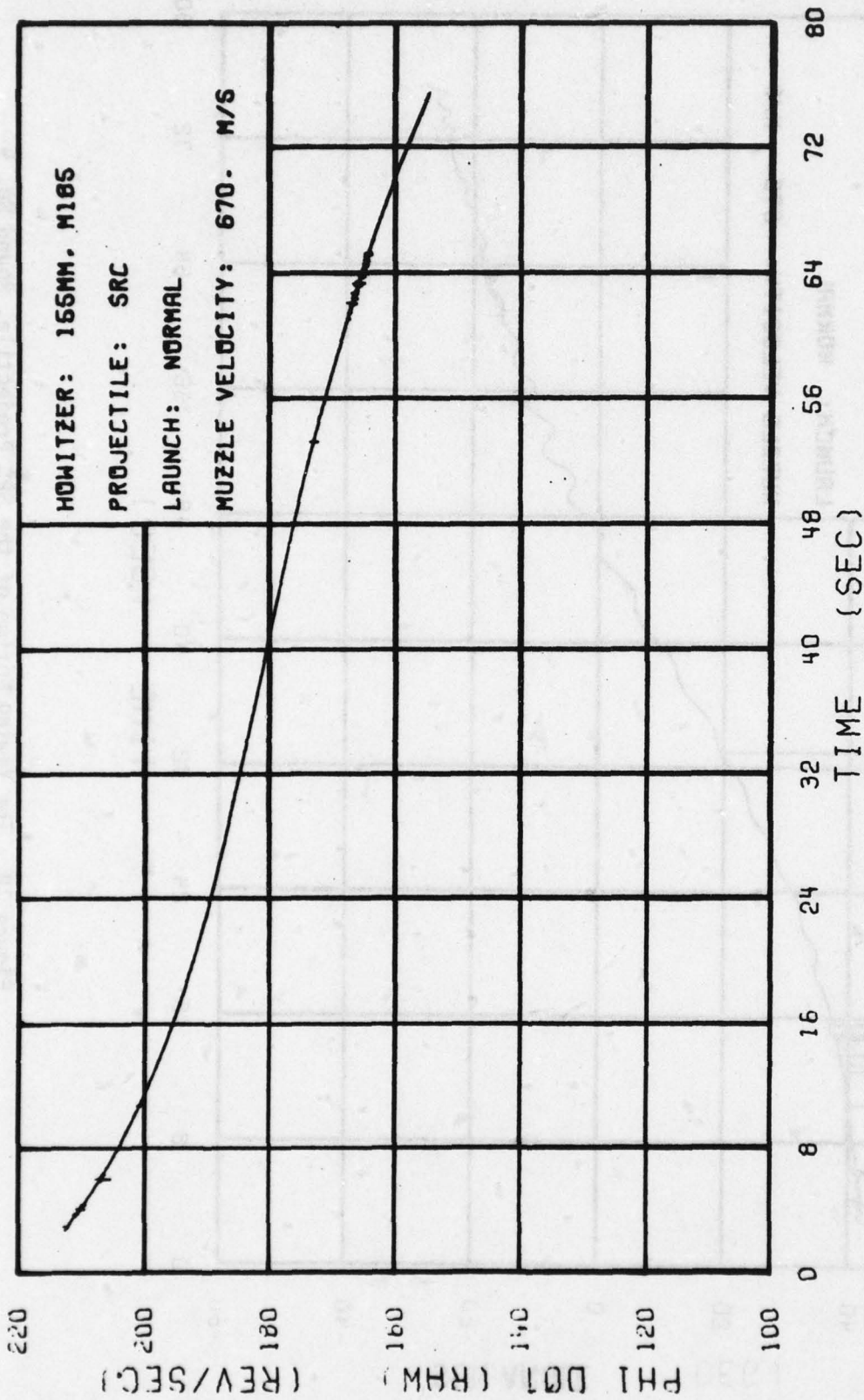

Figure 20. The Spin Motion of the SRC Projectile, Round No. 9

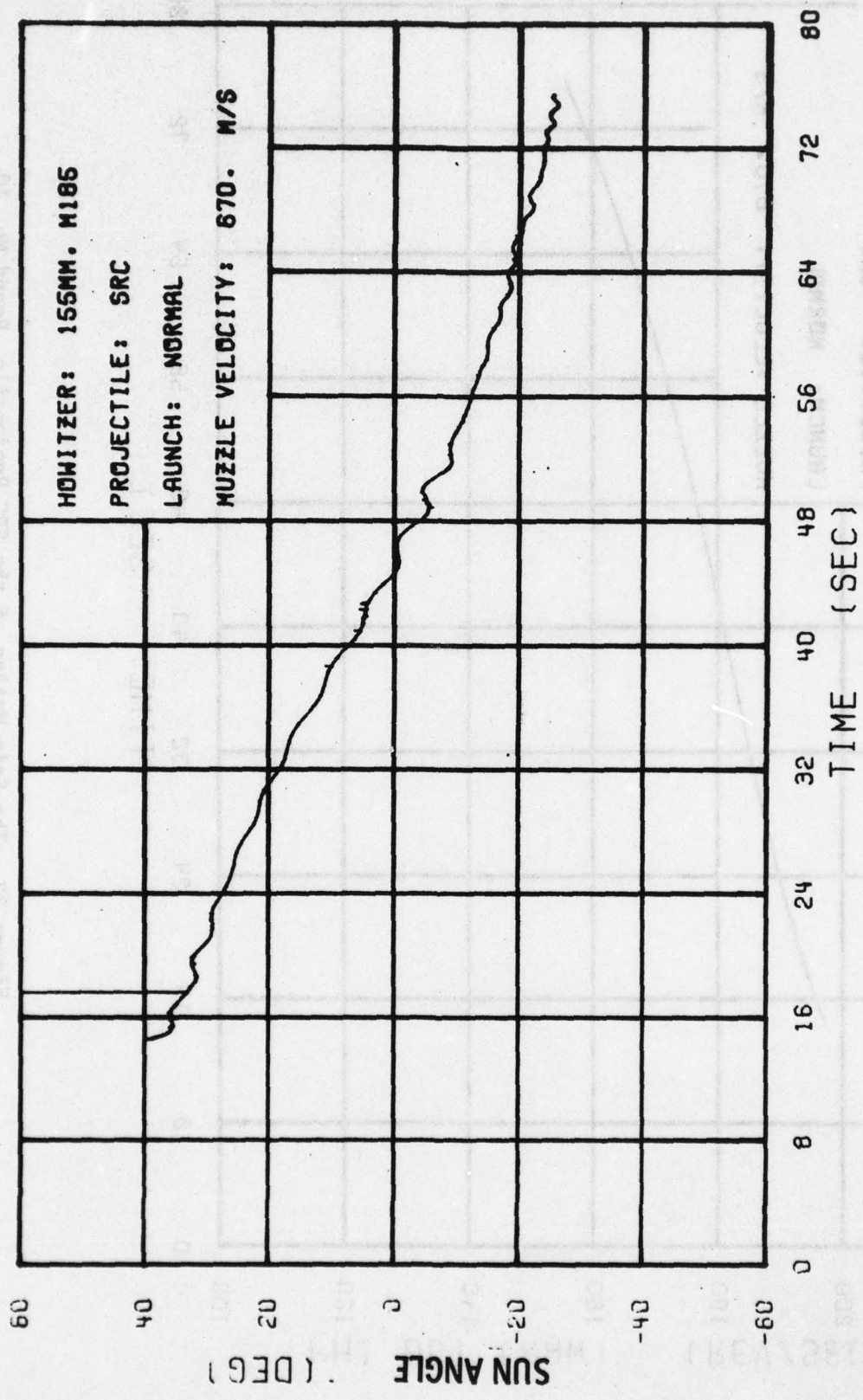

Figure 21. The Yawing Motion of the SRC Projectile, Round No. 10

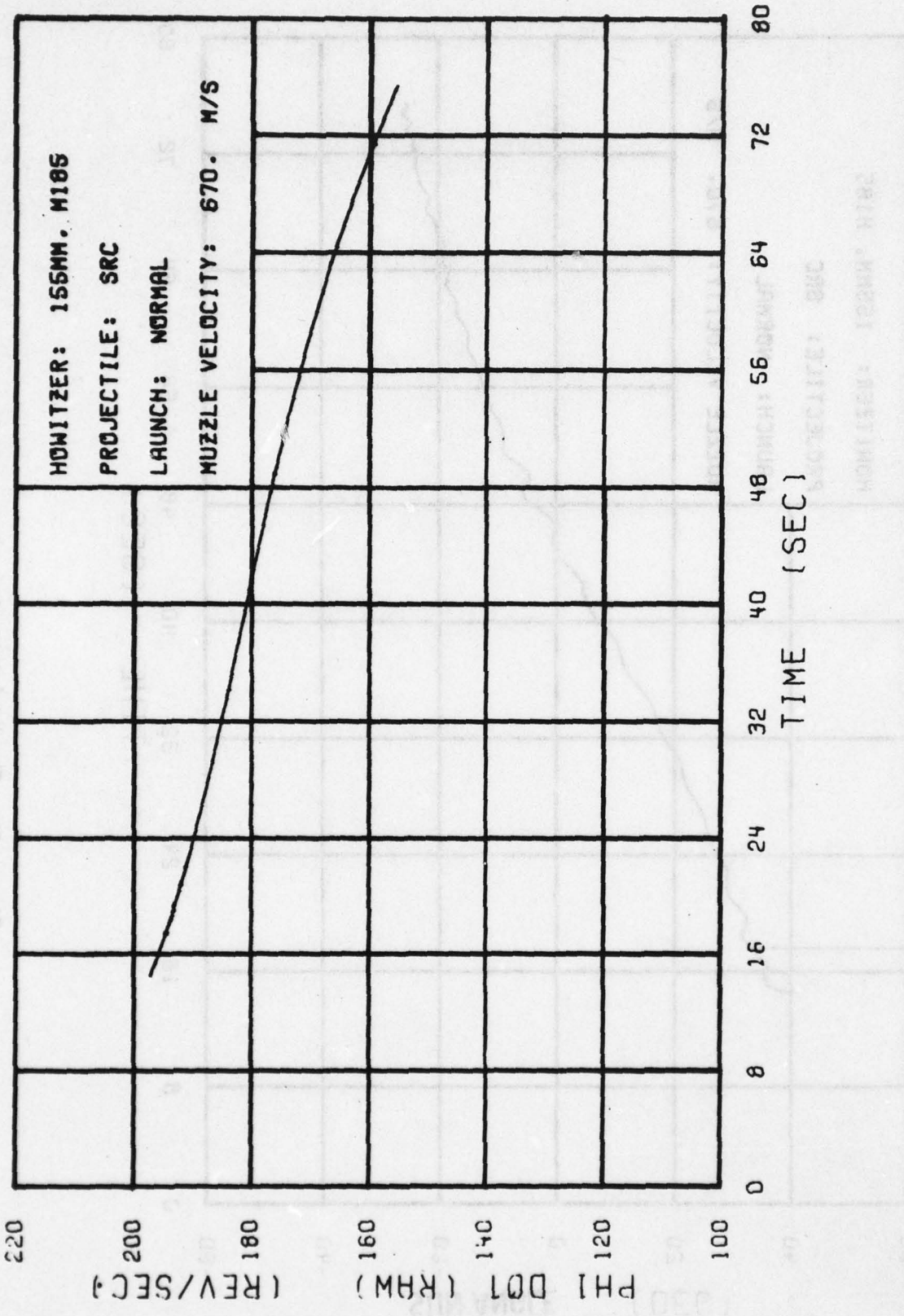

Figure 22. The Spin Motion of the SRC Projectile, Round No. 10

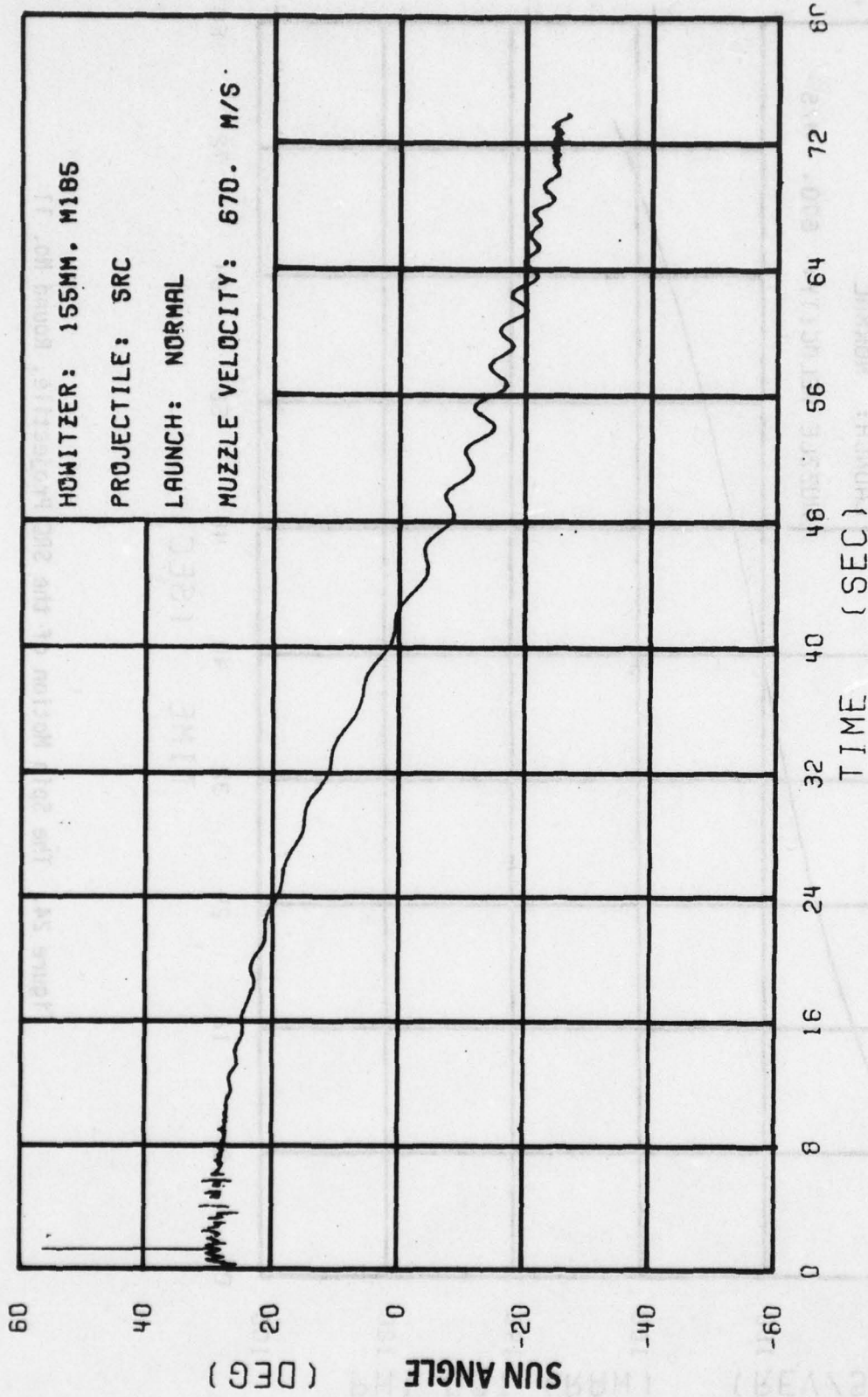

Figure 23. The Yawing Motion of the SRC Projectile, Round No. 11

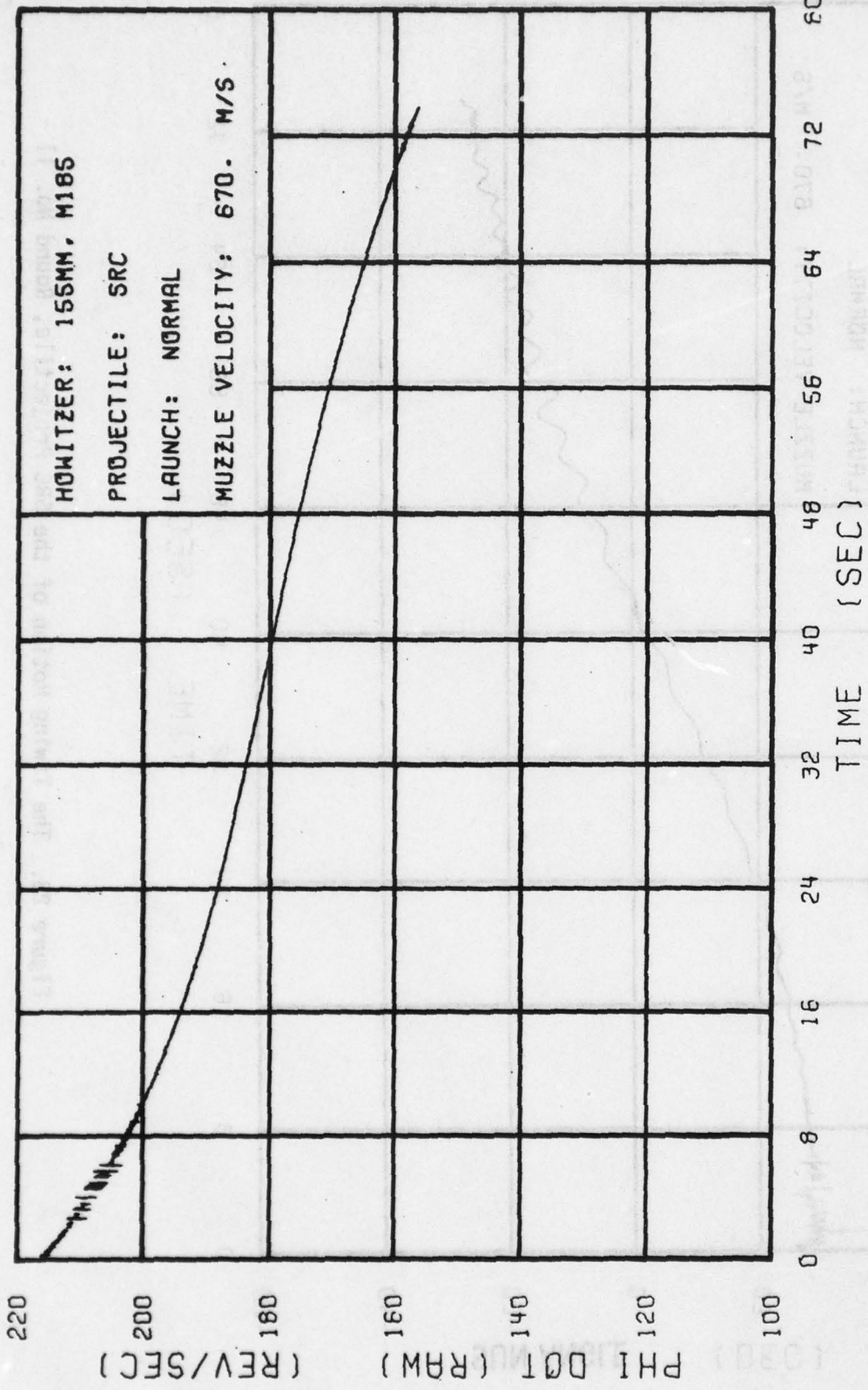

Figure 24. The Spin Motion of the SRC Projectile, Round No. 11

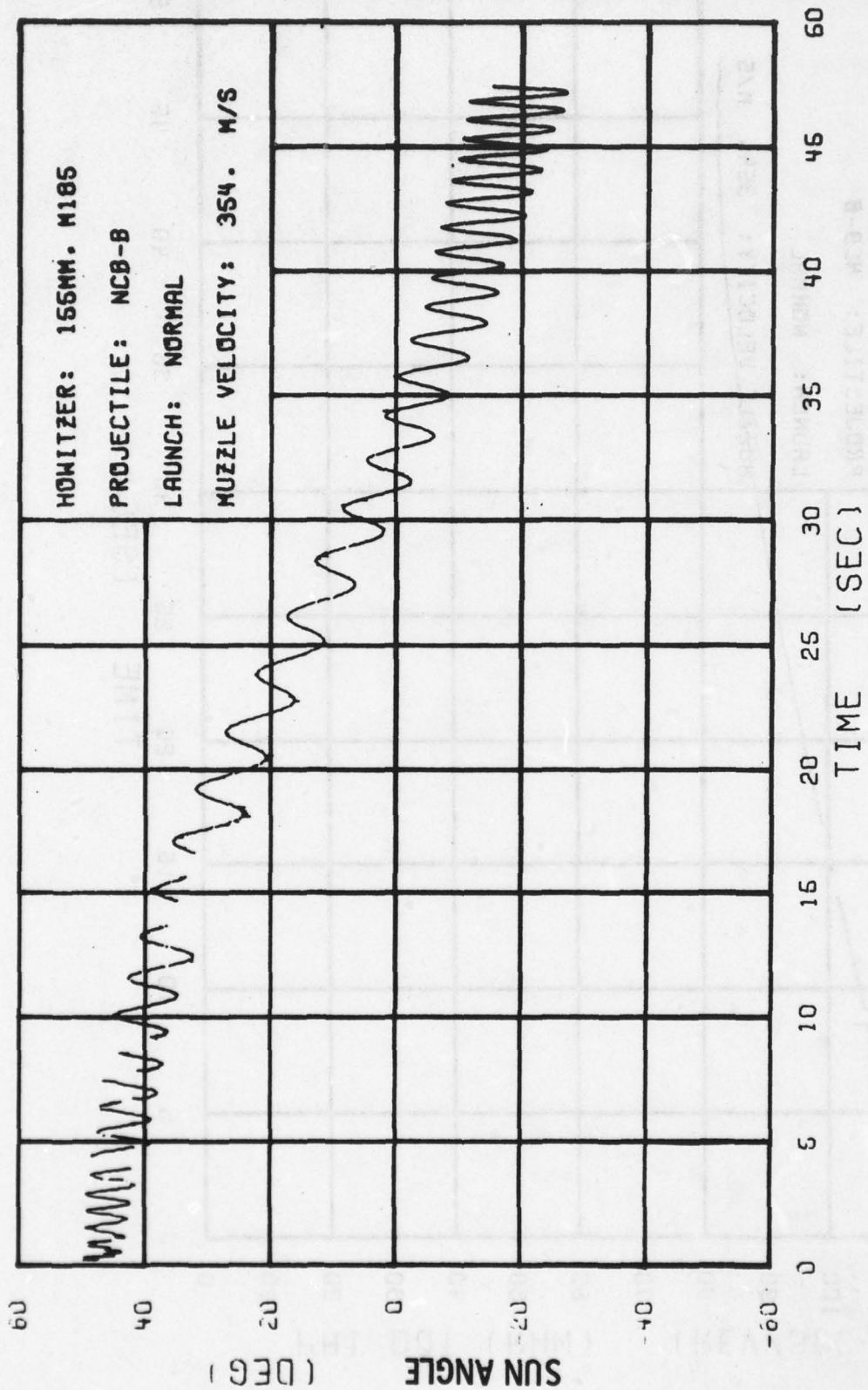

Figure 25. The Yawing Motion of the NCB-B Projectile, Round No. 14

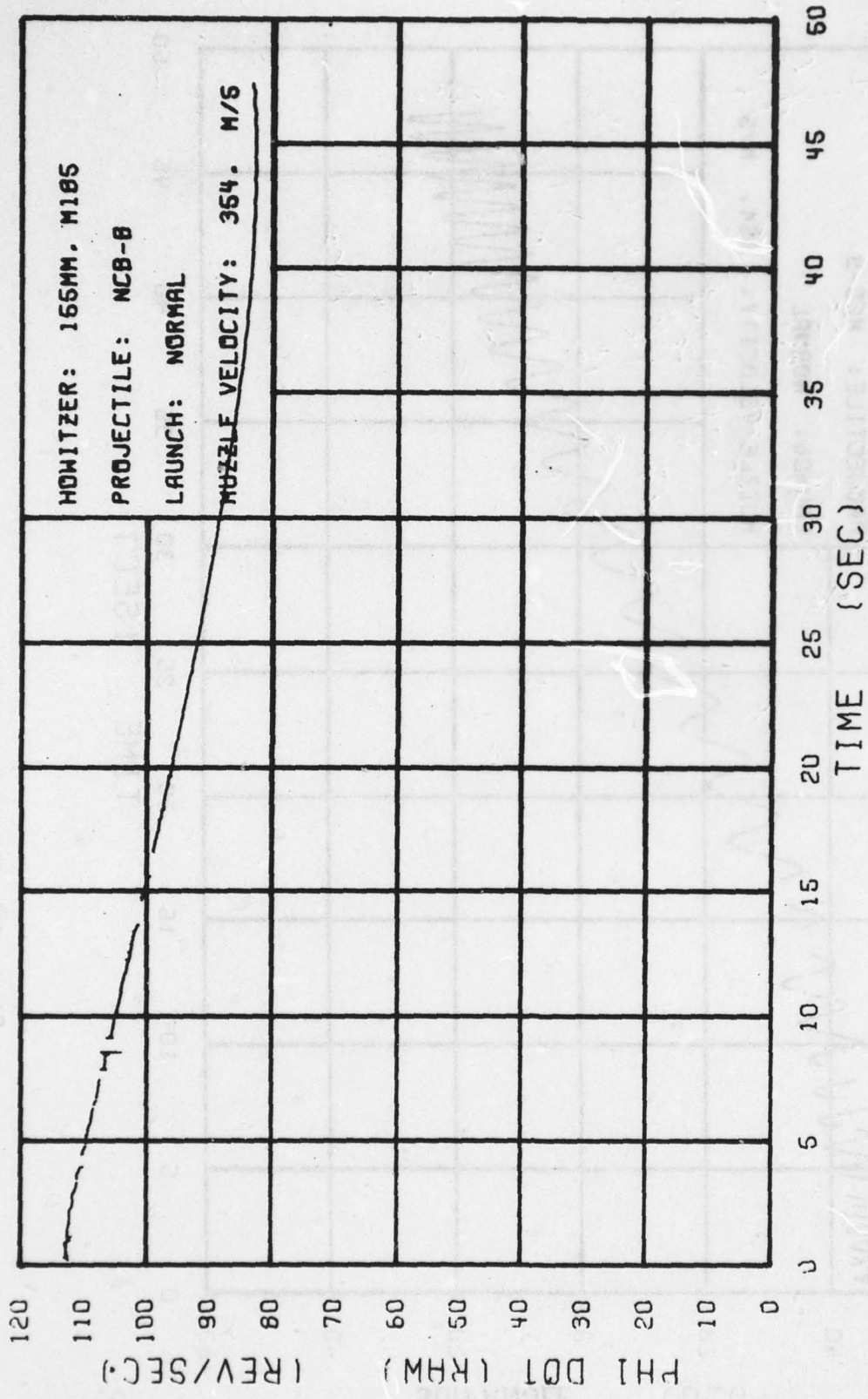

Figure 26. The Spin Motion of the NCB-B Projectile, Round No. 14

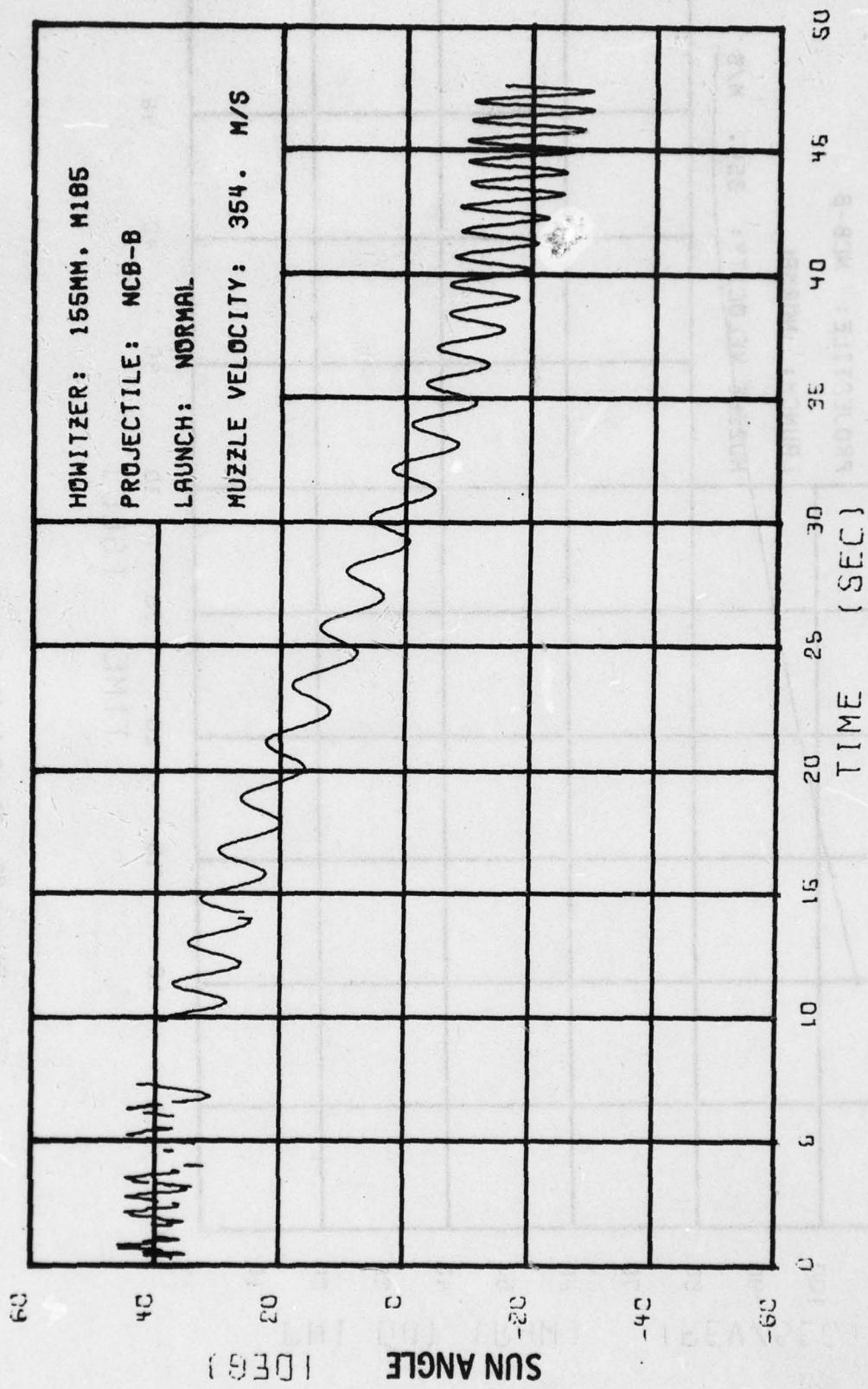

Figure 27. The Yawing Motion of the NCB-B Projectile, Round No. 16

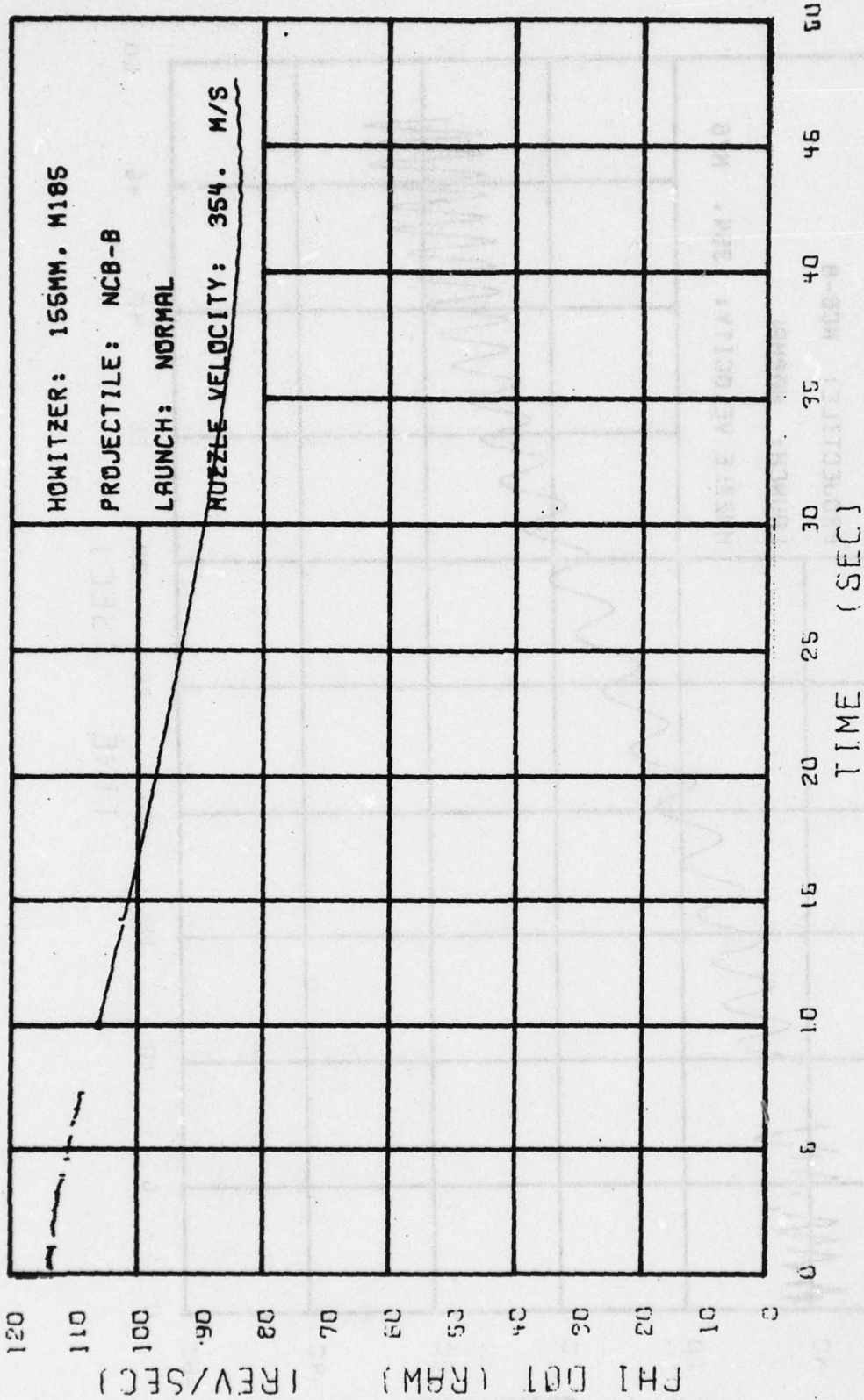

Figure 28. The Spin Motion of the NCB-B Projectile, Round No. 16

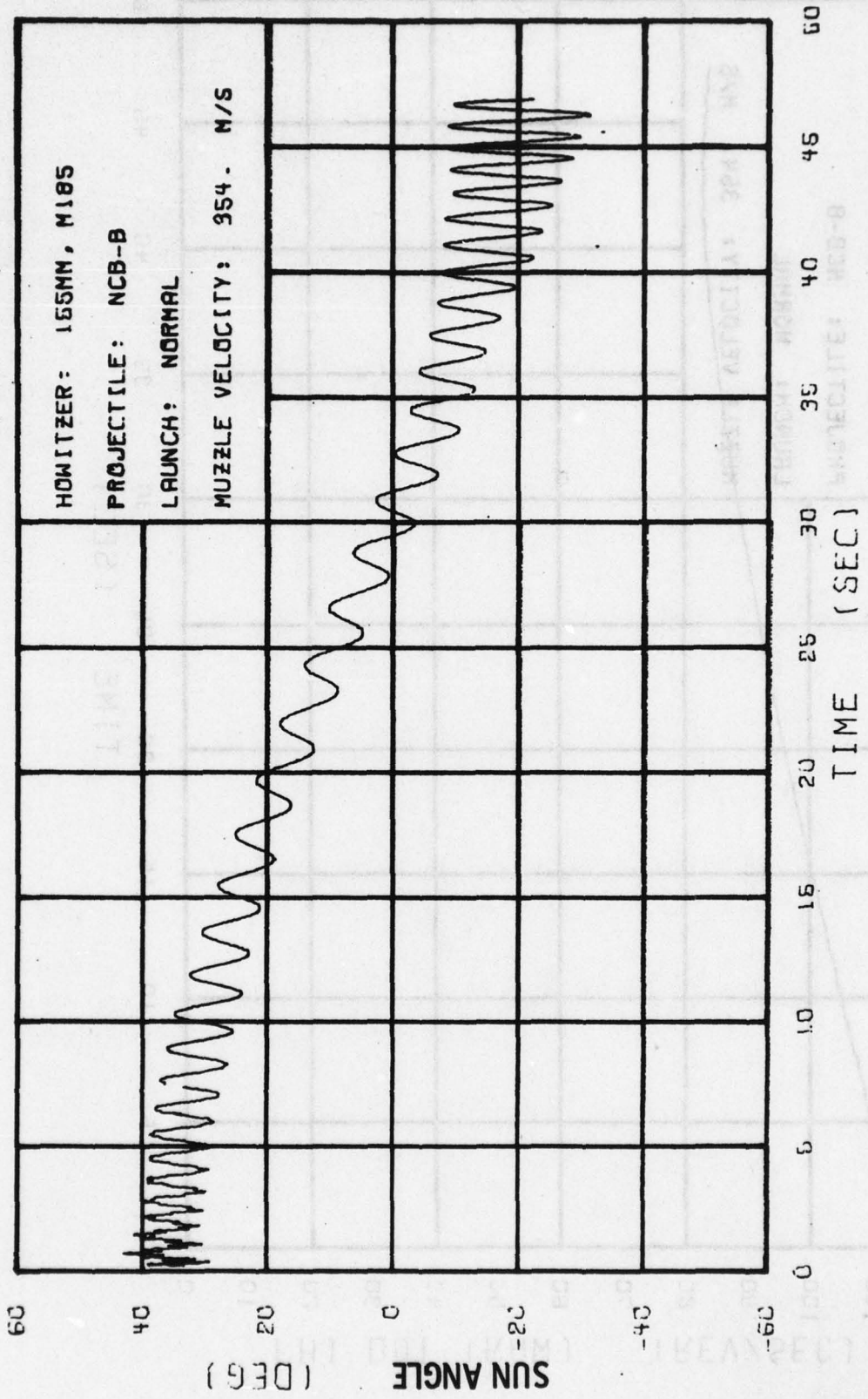

Figure 29. The Yawing Motion of the NCB-B Projectile, Round No. 17

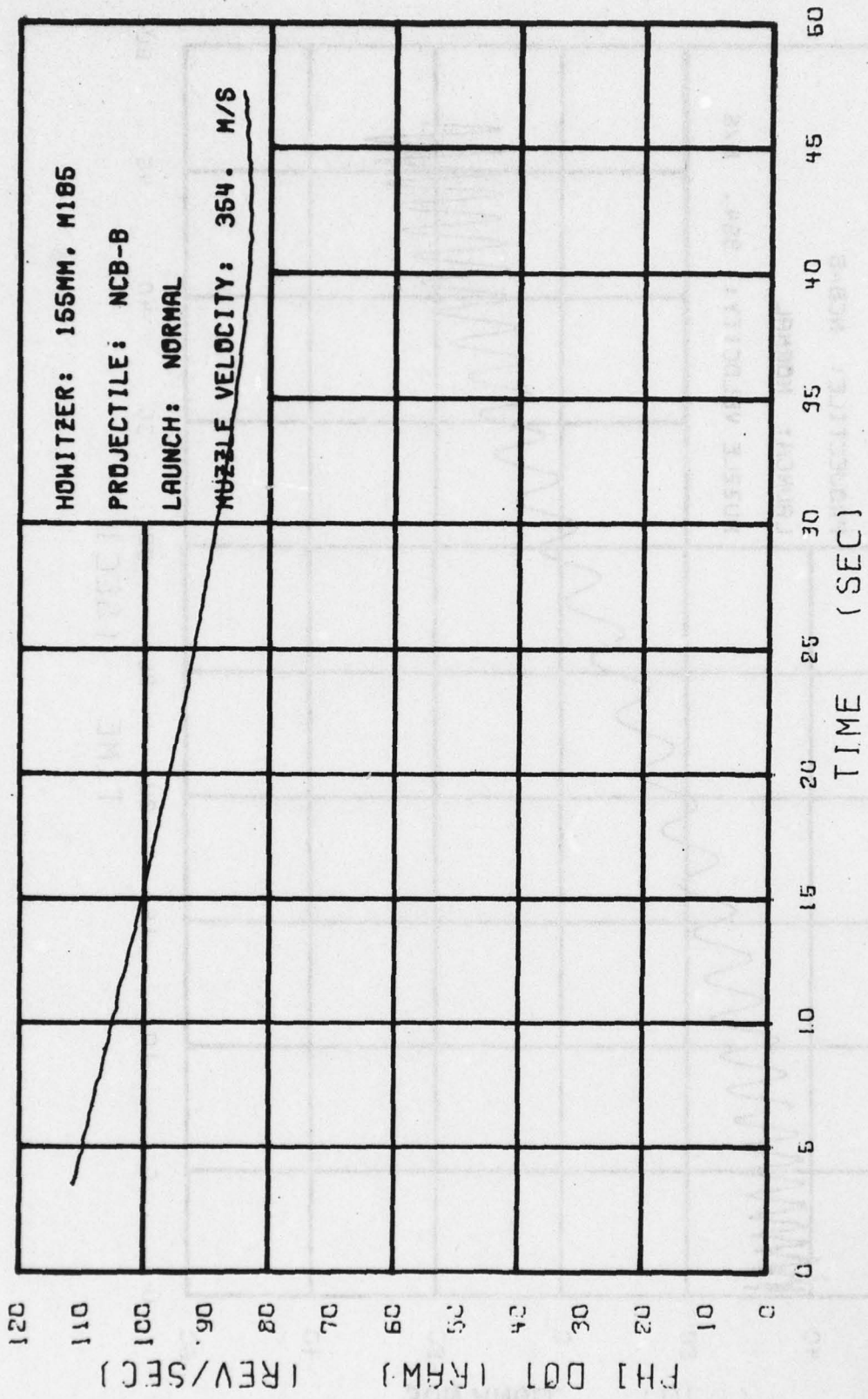

Figure 30. The Spin Motion of the NCB-B Projectile, Round No. 17

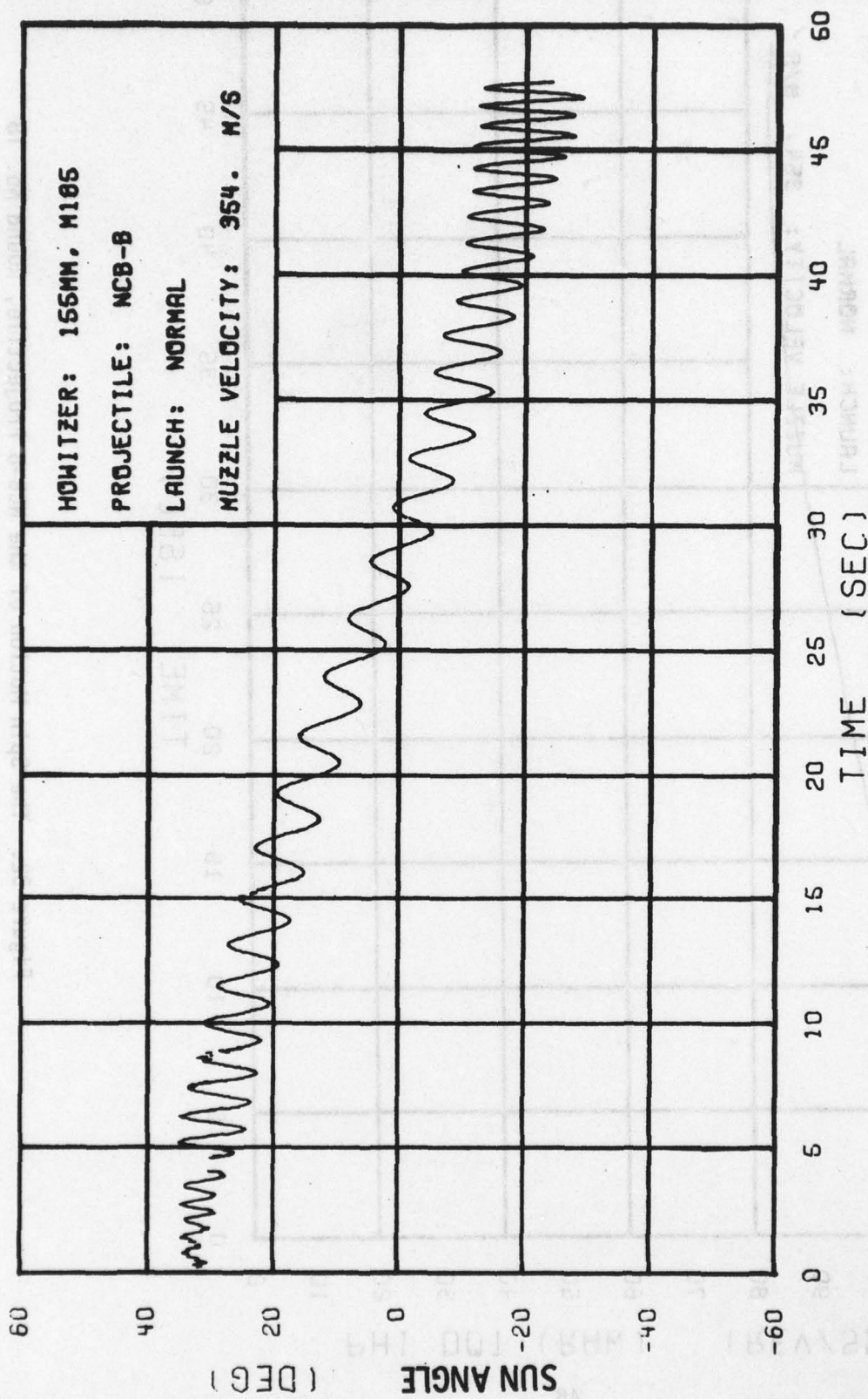

Figure 31. The Yawing Motion of the NCB-B Projectile, Round No. 18

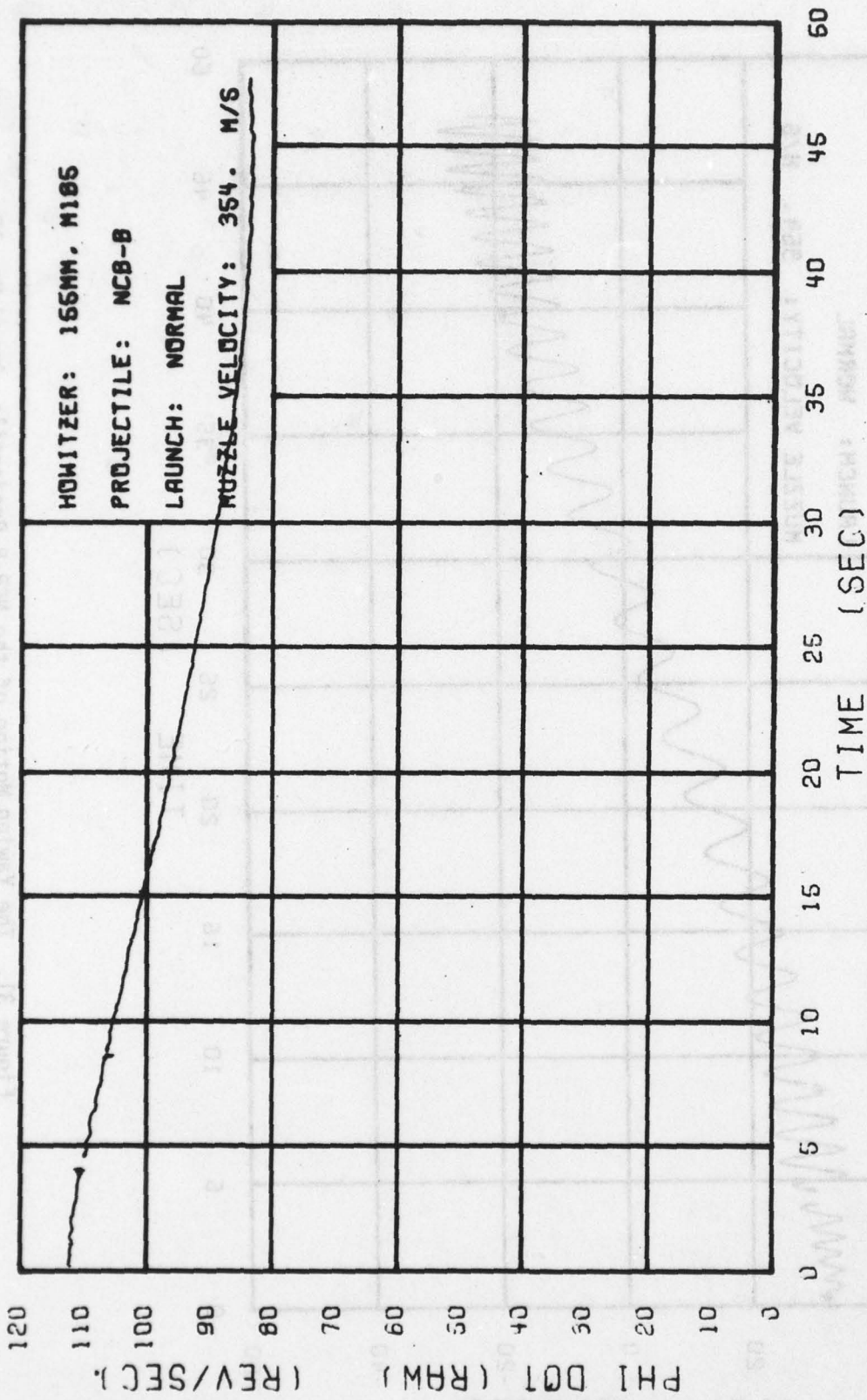

Figure 32. The Spin Motion of the NCB-B Projectile, Round No. 18

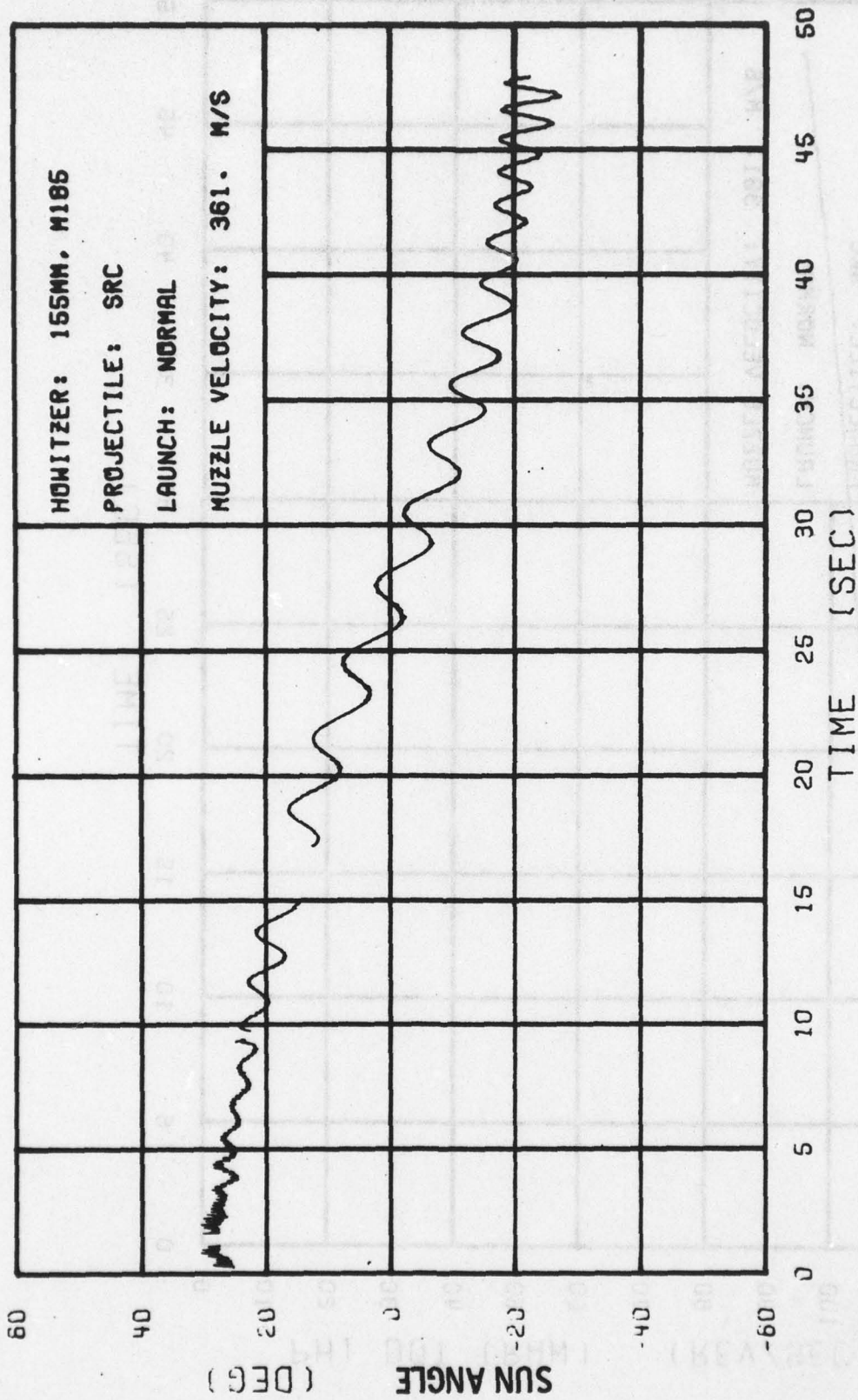

Figure 33. The Yawing Motion of the SRC Projectile Round No. 19

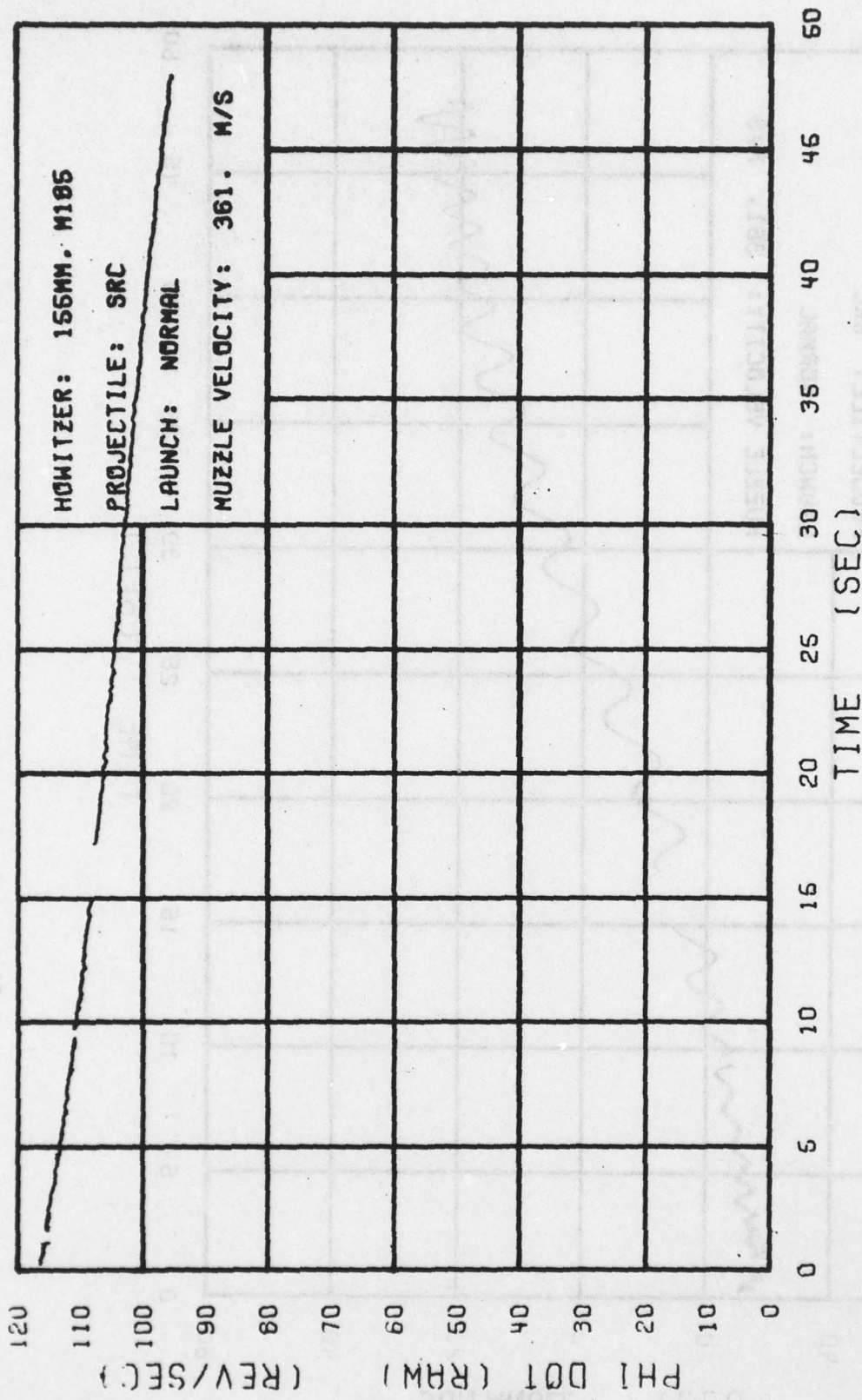

Figure 34. The Spin Motion of the SRC Projectile Round No. 19

LITHO 30' DIA 2010 101104 04 495 28C 1407000115 101104 10' 50

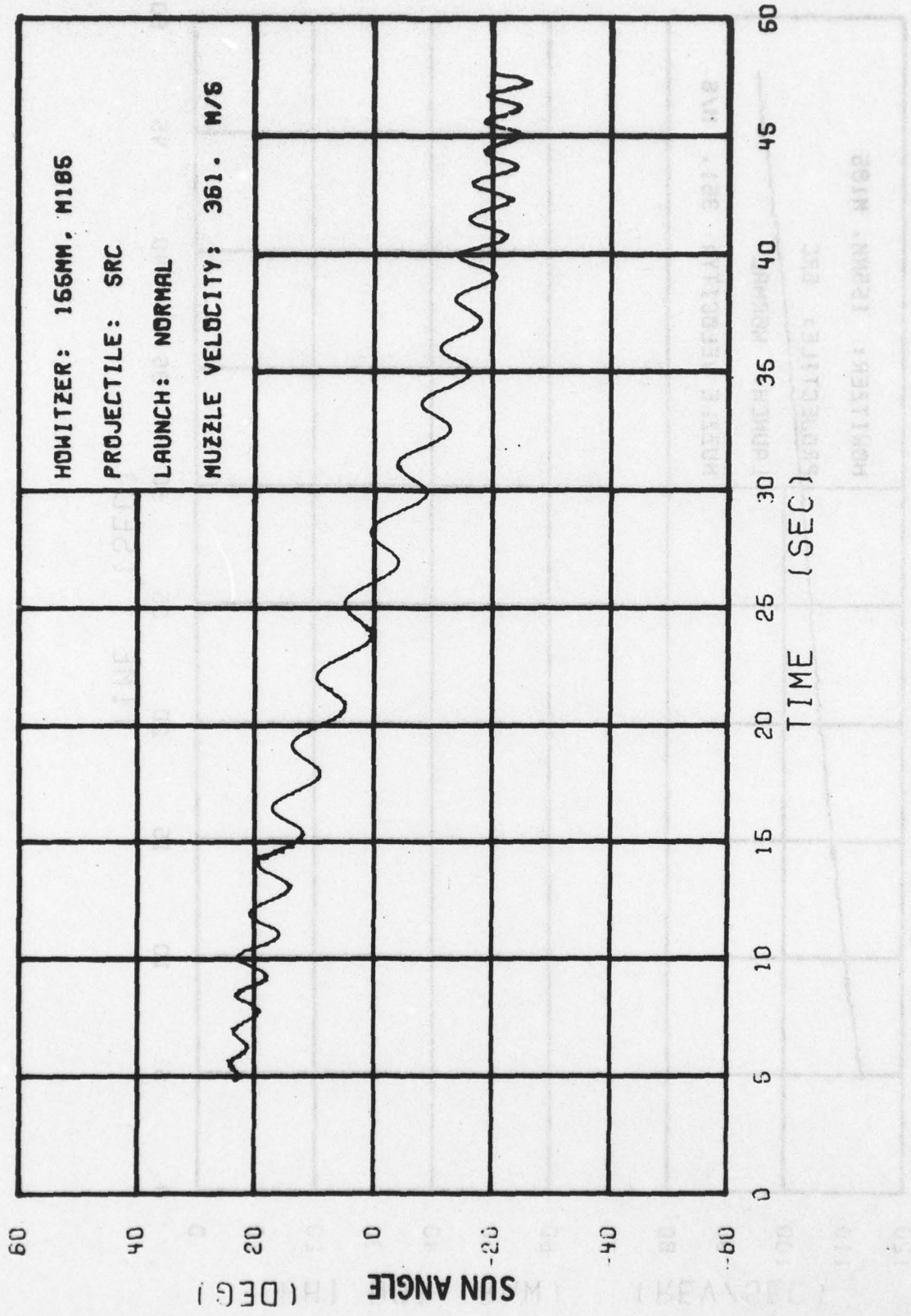

Figure 35. The Yawing Motion of the SRC Projectile Round No. 20

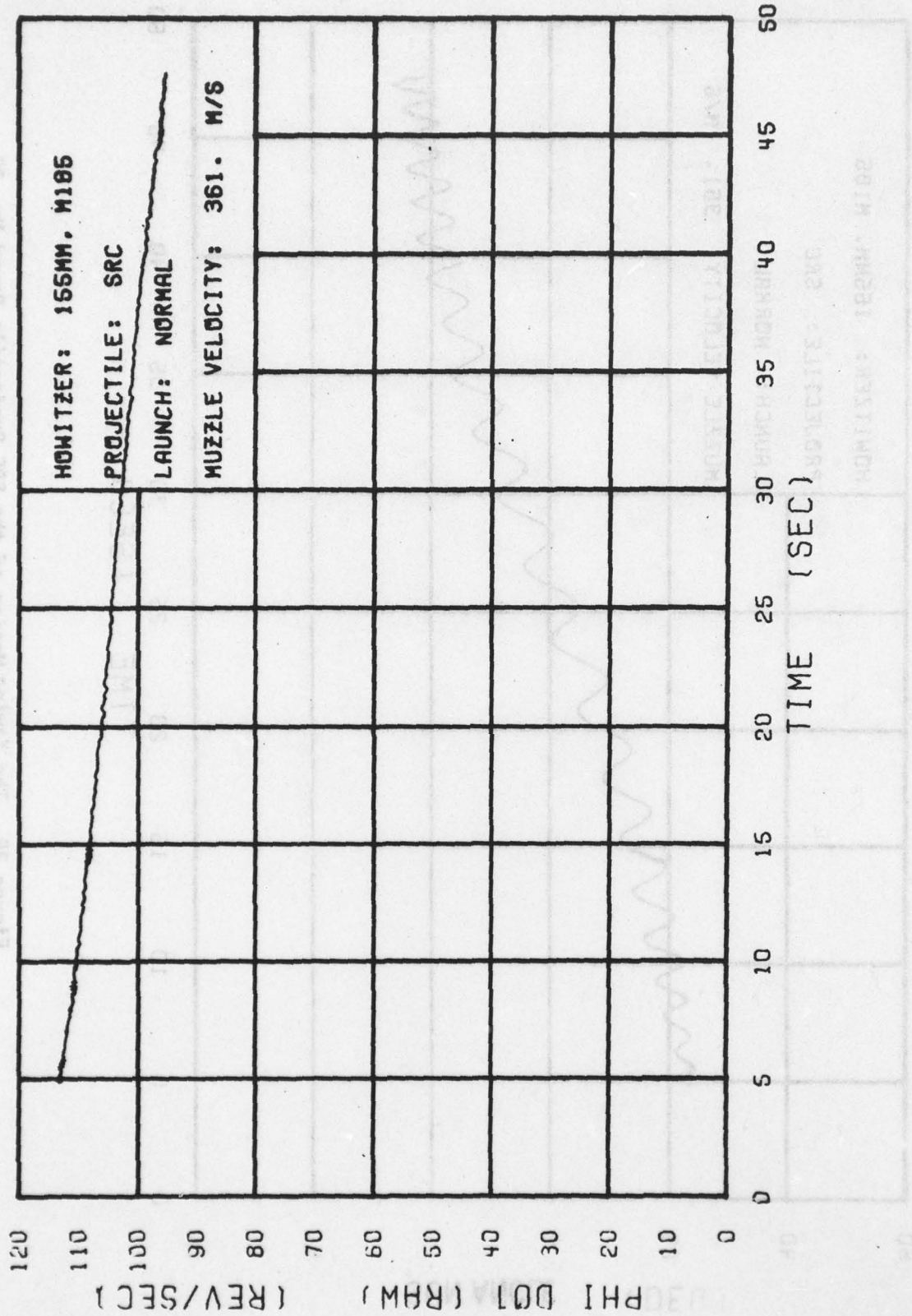

Figure 36. The Spin Motion of the SRC Projectile Round No. 20

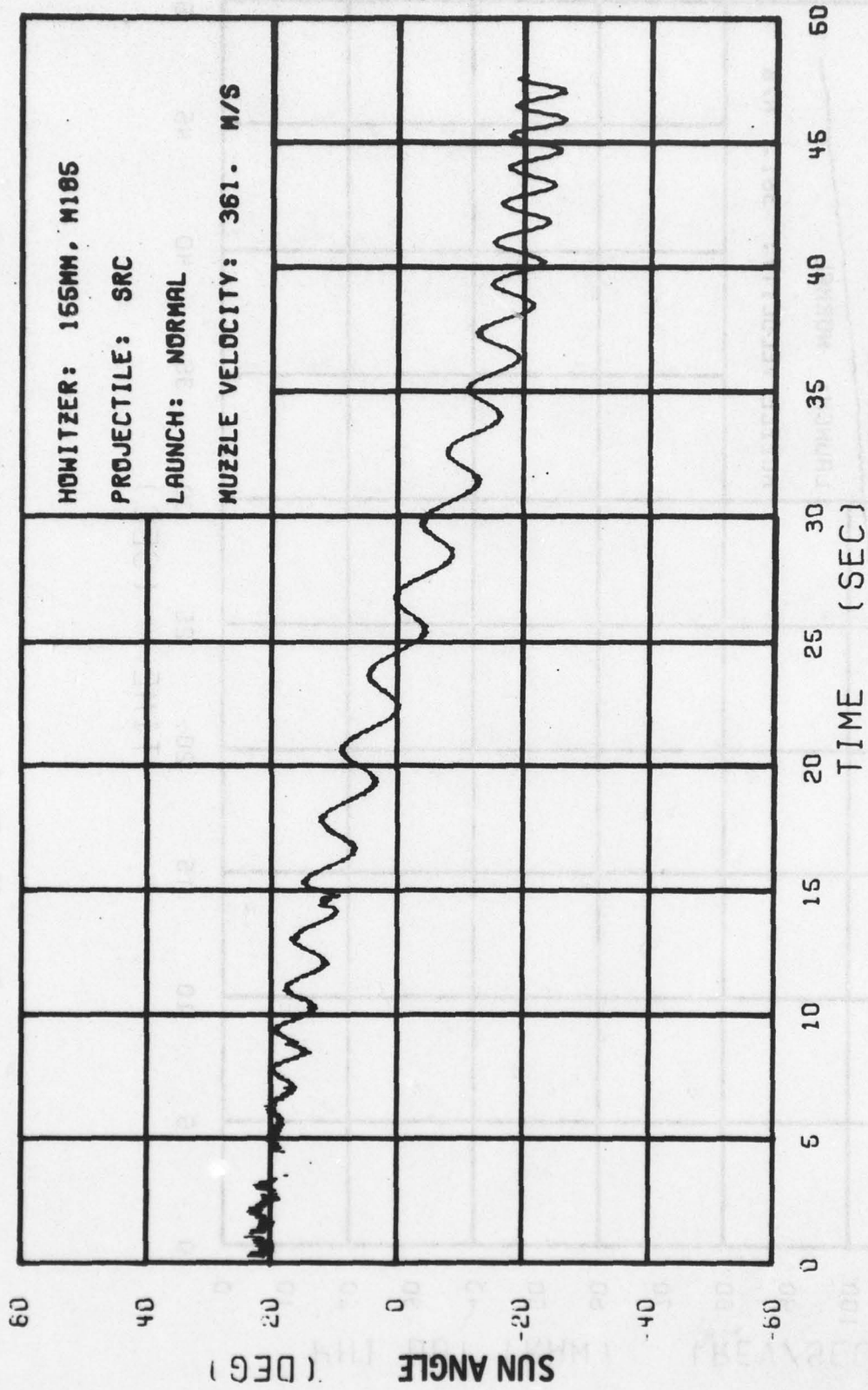

Figure 37. The Yawing Motion of the SRC Projectile Round No. 21

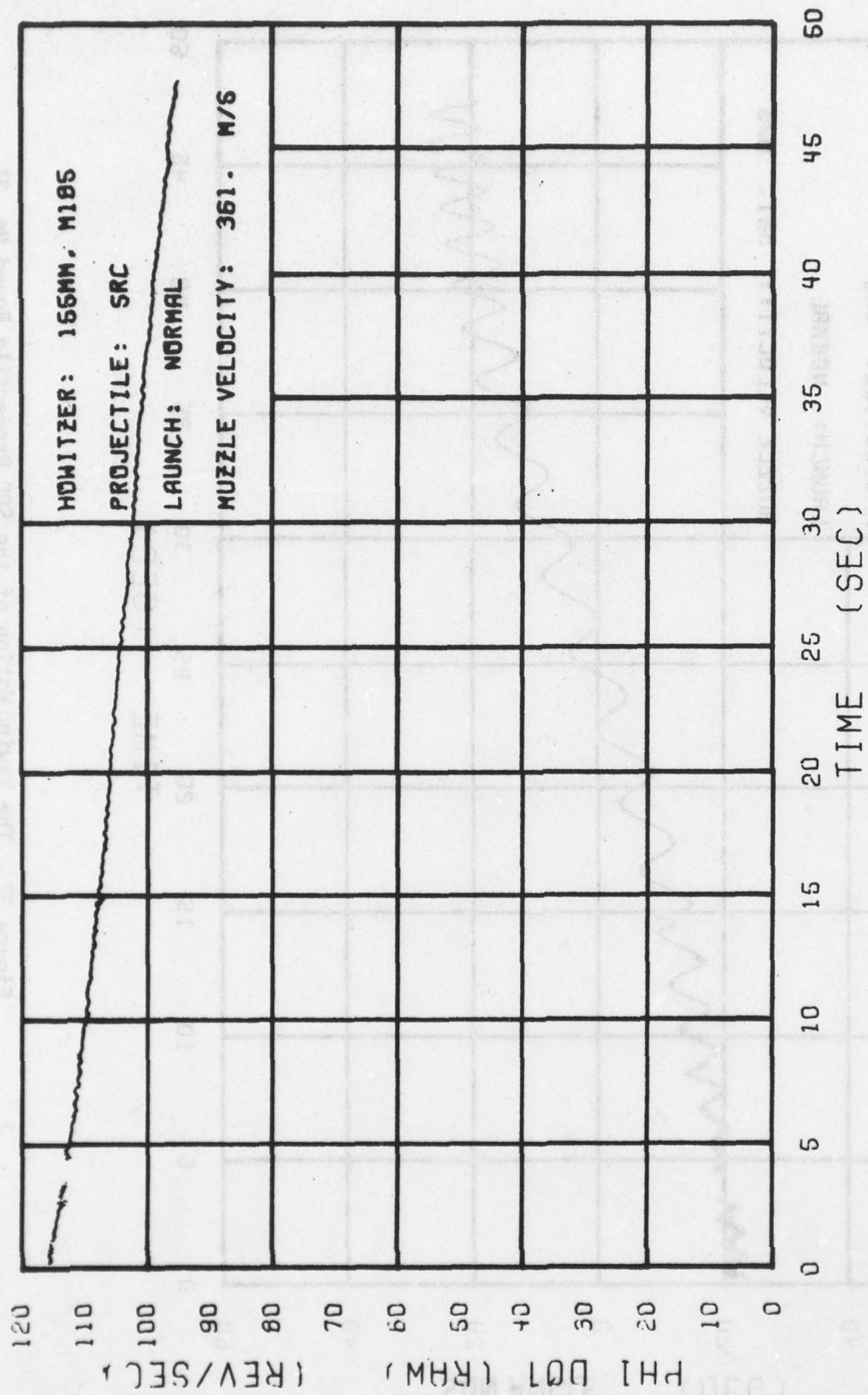

Figure 38. The Spin Motion of the SRC Projectile Round No. 21

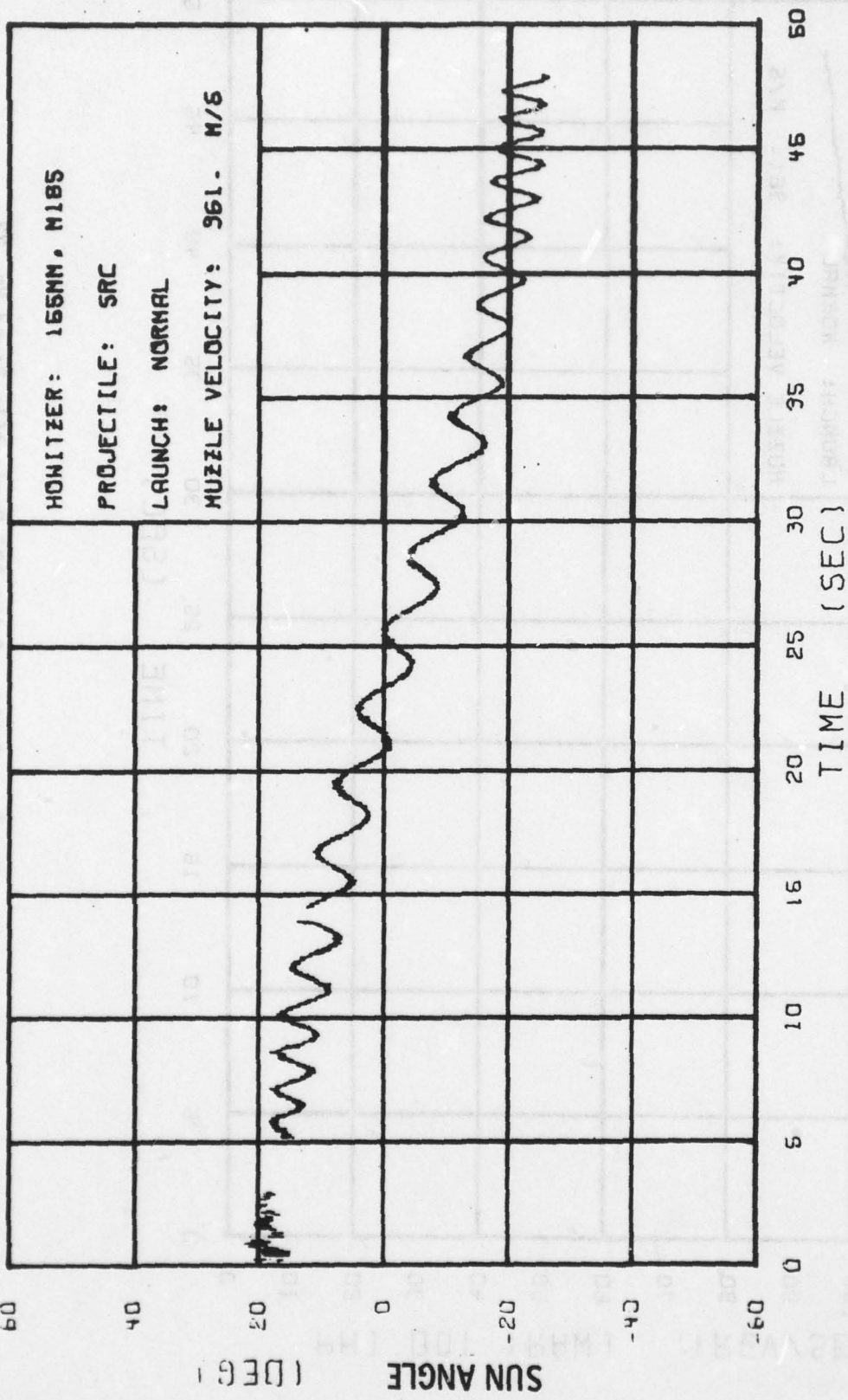

Figure 39. The Yawing Motion of the SRC Projectile Round No. 22

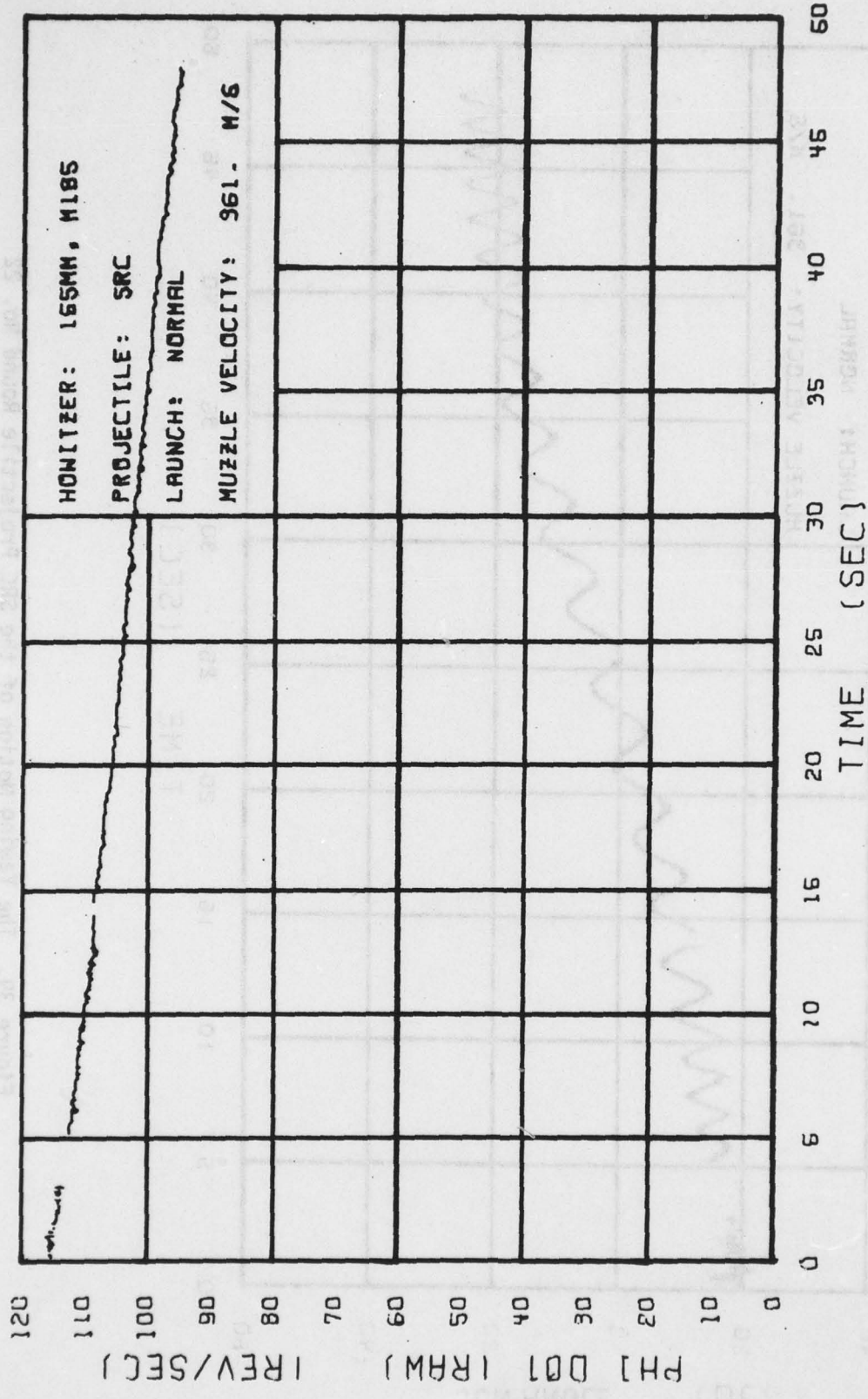

Figure 40. The Spin Motion of the SRC Projectile Round No. 22

REFERENCES

1. Anders S. Platou, "An Improved Projectile Boattail. Part IV," Ballistic Research Laboratory Memorandum Report ARBRL-MR-02826, April 1978. AD B027520L.
2. John H. Whiteside, "Transonic Tests of the 155mm Non-Conical Boattail Projectile A and 8-Inch XM650E4 and EBVP Projectiles at Nicolet, Canada, During January-February 1977," Ballistic Research Laboratory Memorandum Report ARBRL-MR-02809, January 1978. AD B027297L.
3. Vural Oskay and Anders S. Platou, "Yawsonde Tests of 155mm M549 Non-Conical Boattail Projectile at Tonopah Test Range," to be published as a Ballistic Research Laboratory Memorandum Report, Aberdeen Proving Ground, Maryland.
4. Anders S. Platou, "Yawsonde Flights of 155mm Non-Conical Boattail Projectile Configurations at Tonopah Test Range--October 1977," ARBRL-MR-02881, November 1978, U.S. Army Ballistic Research Laboratory, Aberdeen Proving Ground, Maryland.

DISTRIBUTION LIST

<u>No. of Copies</u>	<u>Organization</u>	<u>No. of Copies</u>	<u>Organization</u>
12	Commander Defense Documentation Center ATTN: DDC-DDA Cameron Station Alexandria, VA 22314	3	Commander US Army Missile Research and Development Command ATTN: DRDMI-R DRDMI-RDK Mr. R. Deep Mr. R. Becht Redstone Arsenal, AL 35809
1	Commander US Army Materiel Development and Readiness Command ATTN: DRCDMD-ST, N. Klein 5001 Eisenhower Avenue Alexandria, VA 22333	1	Commander US Army Missile Research and Development Command ATTN: DRDMI-YDL Redstone Arsenal, AL 35809
1	Commander US Army Aviation Research and Development Command ATTN: DRSV-E P. O. Box 209 St. Louis, MO 63166	1	Commander US Army Tank Automotive Research & Development Cmd ATTN: DRDTA-UL Warren, MI 48090
1	Director US Army Air Mobility Research and Development Laboratory Ames Research Center Moffett Field, CA 94035	8	Commander US Army Armament Research and Development Command ATTN: DRDAR-TSS (2 cys) DRDAR-LCA-F Mr. D. Mertz Mr. E. Falkowski Mr. A. Loeb Mr. R. Kline Mr. S. Kahn Mr. S. Wasserman Dover, NJ 07801
1	Commander US Army Electronics Research and Development Command Technical Support Activity ATTN: DELSD-L Fort Monmouth, NJ 07703	1	Commander US Army Armament Materiel Readiness Command ATTN: DRSAR-LEP-L, Tech Lib Rock Island, IL 61299
1	Commander US Army Communications Research and Development Command ATTN: DRDCO-PPA-SA Fort Monmouth, NJ 07703	1	Director US Army TRADOC Systems Analysis Activity ATTN: ATAA-SL, Tech Lib White Sands Missile Range NM 88002
1	Commander US Army Jefferson Proving Ground ATTN: STEJP-TD-D Madison, IN 47250		

PRECEDING PAGE BLANK - NOT FILMED

DISTRIBUTION LIST

<u>No. of Copies</u>	<u>Organization</u>	<u>No. of Copies</u>	<u>Organization</u>
1	Commander US Army Natick Research and Development Command ATTN: DRXRE, Dr. D. Sieling Natick, MA 01762	1	Commander US Naval Weapons Center ATTN: Technical Library China Lake, CA 93555
1	Commander US Army Research Office P. O. Box 12211 Research Triangle Park NC 27709	1	AFATL (DLDL) Eglin AFB, FL 32542
3	Commander US Naval Air Systems Command ATTN: AIR-604 Washington, D. C. 20360	1	Director NASA Langley Research Center ATTN: MS-185, Tech Lib Langley Station Hampton, VA 23365
2	Commander David W. Taylor Naval Ship Research and Development Center ATTN: Dr. S. de los Santos Mr. Stanley Gottlieb Bethesda, Maryland 20084	1	Director NASA Ames Research Center ATTN: MS-202, Tech Lib Moffett Field, CA 94035
4	Commander US Naval Surface Weapons Center ATTN: Dr. T. Clare, Code DK20 Dr. P. Daniels Mr. D. A. Jones III Mr. L. Mason Dahlgren, VA 22448	1	Arnold Research Organization, Inc. von Karman Gas Dynamics Facility ATTN: Dr. John C. Adams, Jr. Aerodynamics Division Projects Branch Arnold AFS, TN 37389
4	Commander US Naval Surface Weapons Center ATTN: Code 312 Mr. S. Hastings Mr. F. Regan Mr. J. Knott Mr. R. Schlie Silver Spring, MD 20910	1	Calspan Corporation ATTN: Mr. J. Andes, Head Transonic Tunnel Dept. P. O. Box 235 Buffalo, NY 14221
		1	Honeywell, Inc. ATTN: Mr. George Stilley 600 Second Street, N. Hopkins, MN 55343
		1	Sandia Laboratories ATTN: Division No. 1331 Mr. H. R. Vaughn Albuquerque, NM 87115

DISTRIBUTION LIST

<u>No. of Copies</u>	<u>Organization</u>	<u>No. of Copies</u>	<u>Organization</u>
2	Space Research Corporation ATTN: Dr. G. V. Bull Dr. D. Lister North Jay Road P. O. Box 60 North Troy, VT 05859	1	University of Virginia Department of Aerospace Engineering and Engineering Physics ATTN: Prof. I. Jacobson Charlottesville, VA 22904
2	Massachusetts Institute of Technology ATTN: Prof. E. Covert Prof. C. Haldeman 77 Massachusetts Avenue Cambridge, MA 02139		<u>Aberdeen Proving Ground</u> Dir, USAMSAA ATTN: Dr. J. Sperrazza DRXSJ-MP, H. Cohen Cdr, USATECOM ATTN: DRSTE-SG-H Dir, Wpns Sys Concepts Team Bldg. E3516, EA ATTN: DRDAR-ACW Mr. M. Miller Mr. A. Flatau Dir, Biophysics Lab, EA ATTN: Mr. W. Sacco Bldg. 3160
1	MIT/Lincoln Laboratories ATTN: Dr. Milan Vlainac Mail Stop D-382 P. O. Box 73 Lexington, MA 02173		
1	Rutgers University Mechanical, Industrial, and Aerospace Engineering Department ATTN: Dr. Robert H. Page New Brunswick, NJ 08903		
1	University of Delaware Mechanical and Aerospace Engineering Department ATTN: Dr. J. E. Danberg Newark, DE 19711		