

AD-A069 191

ARMY MISSILE RESEARCH AND DEVELOPMENT COMMAND REDSTO--ETC F/G 20/11
DETERMINATION OF ELASTIC CONSTANTS FOR FLAWED AND UNFLAWED COMP--ETC(U)
MAR 79 T L VANDIVER
DRDMI-T-79-36

UNCLASSIFIED

NL

1 OF 2
AD A069191

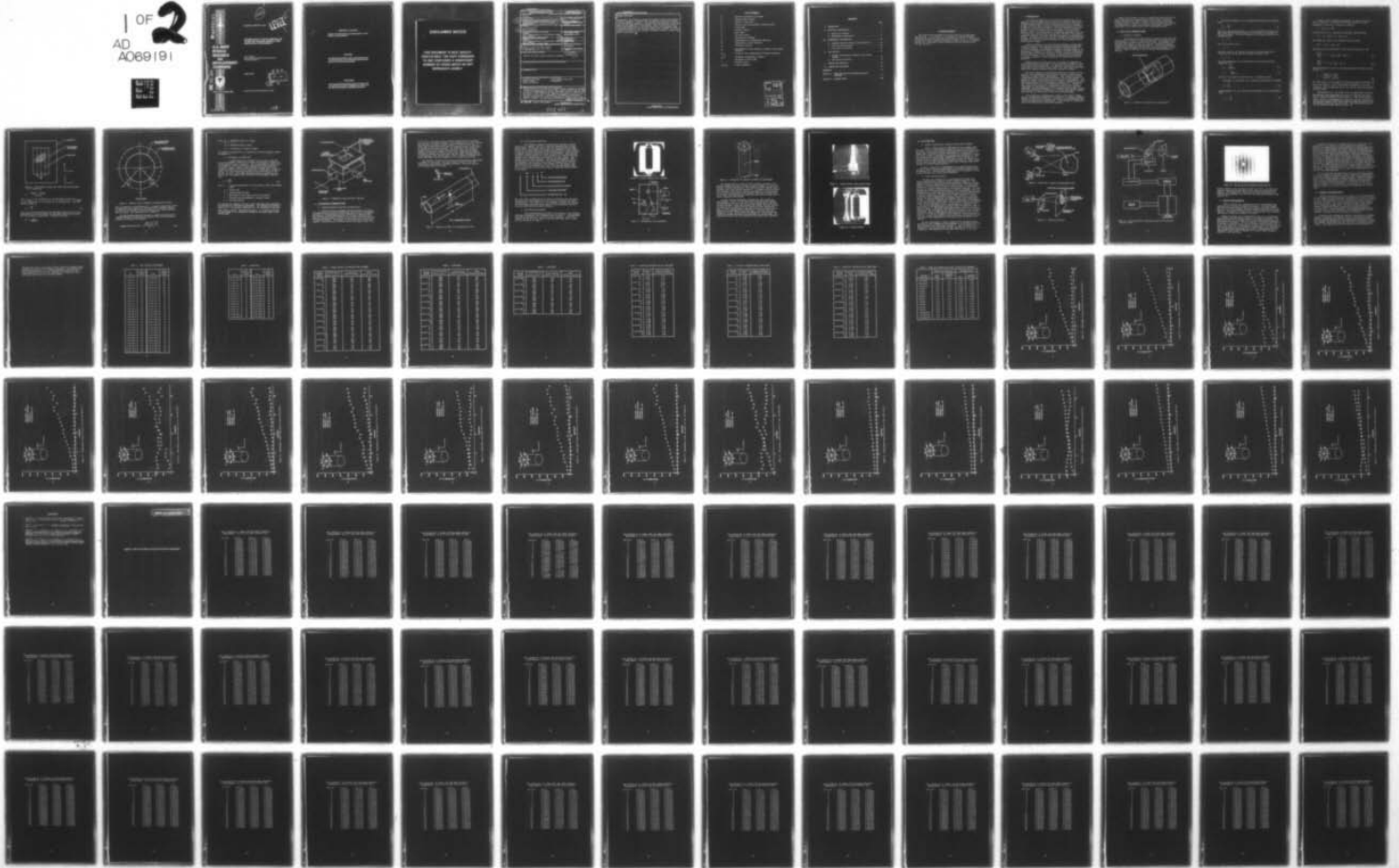

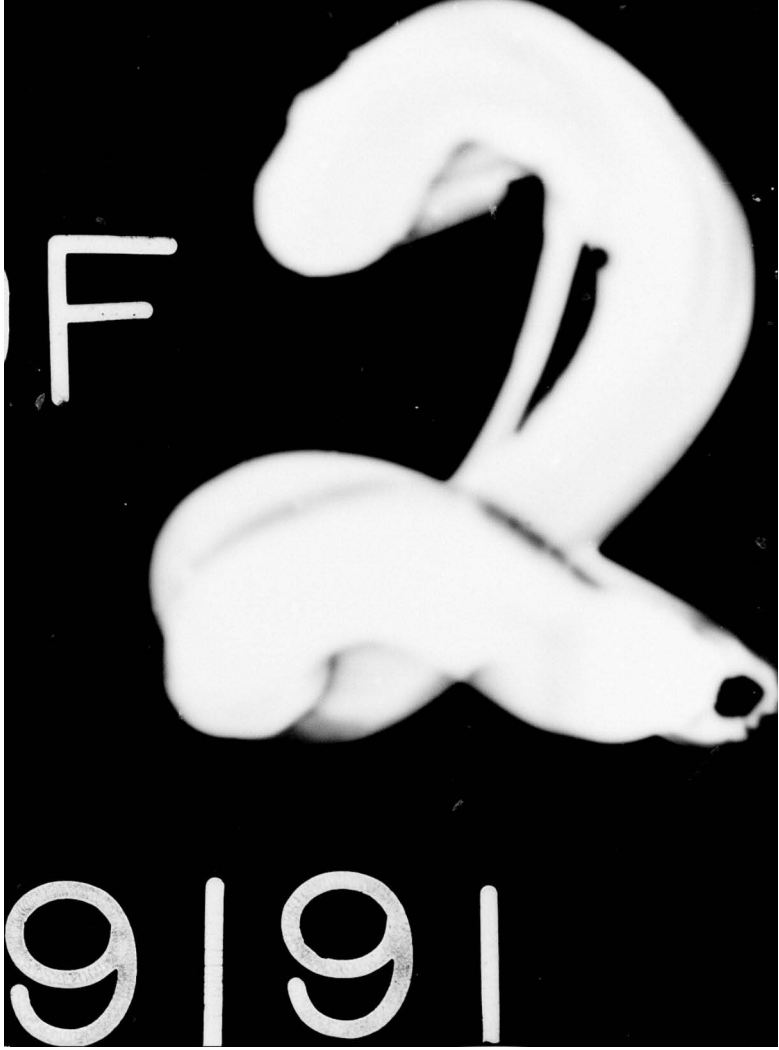

AD A069191

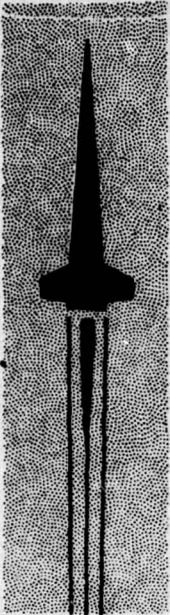

**U.S. ARMY
MISSILE
RESEARCH
AND
DEVELOPMENT
COMMAND**

DDC FILE COPY



Redstone Arsenal, Alabama 35809

DMR FORM 1000, 1 APR 77

42

TECHNICAL REPORT T-79-36

LEVEL H

**DETERMINATION OF ELASTIC CONSTANTS FOR
FLAWED AND UNFLAWED COMPOSITE TUBES
USING SPECKLE INTERFEROMETRY**

Terry L. Vandiver
Ground Equipment and Missile Structures Directorate
Technology Laboratory

8 March 1979

DDC
RECEIVED
JUN 1 1979
A

Approved for public release; distribution unlimited.

79 05 30 208

DISPOSITION INSTRUCTIONS

**DESTROY THIS REPORT WHEN IT IS NO LONGER NEEDED. DO NOT
RETURN IT TO THE ORIGINATOR.**

DISCLAIMER

**THE FINDINGS IN THIS REPORT ARE NOT TO BE CONSTRUED AS AN
OFFICIAL DEPARTMENT OF THE ARMY POSITION UNLESS SO DESIG-
NATED BY OTHER AUTHORIZED DOCUMENTS.**

TRADE NAMES

**USE OF TRADE NAMES OR MANUFACTURERS IN THIS REPORT DOES
NOT CONSTITUTE AN OFFICIAL INDORSEMENT OR APPROVAL OF
THE USE OF SUCH COMMERCIAL HARDWARE OR SOFTWARE.**

DISCLAIMER NOTICE

THIS DOCUMENT IS BEST QUALITY PRACTICABLE. THE COPY FURNISHED TO DDC CONTAINED A SIGNIFICANT NUMBER OF PAGES WHICH DO NOT REPRODUCE LEGIBLY.

UNCLASSIFIED

SECURITY CLASSIFICATION OF THIS PAGE (When Data Entered)

REPORT DOCUMENTATION PAGE		READ INSTRUCTIONS BEFORE COMPLETING FORM
1. REPORT NUMBER T-79-36	2. GOVT ACCESSION NO.	3. RECIPIENT'S CATALOG NUMBER
4. TITLE (and Subtitle) DETERMINATION OF ELASTIC CONSTANTS FOR FLAWED AND UNFLAWED COMPOSITE TUBES USING SPECKLE INTERFEROMETRY.	5. TYPE OF REPORT & PERIOD COVERED Technical Report.	
7. AUTHOR(s) Terry L. Vandiver	6. PERFORMING ORG. REPORT NUMBER T-79-36	
9. PERFORMING ORGANIZATION NAME AND ADDRESS Commander US Army Missile Research and Development Command Attn: DKDMI-TLA Redstone Arsenal, Alabama 35809		8. CONTRACT OR GRANT NUMBER(s)
11. CONTROLLING OFFICE NAME AND ADDRESS Commander US Army Missile Research and Development Command Attn: DRDMI-TI Redstone Arsenal, Alabama 35809		10. PROGRAM ELEMENT, PROJECT, TASK AREA & WORK UNIT NUMBERS AMCMS 612303.2140911
14. MONITORING AGENCY NAME & ADDRESS (if different from Controlling Office) DRDMI-T-79-36		12. REPORT DATE 8 March 1979
16. DISTRIBUTION STATEMENT (of this Report) Approved for public release; distribution unlimited.		13. NUMBER OF PAGES 154
17. DISTRIBUTION STATEMENT (of the abstract entered in Block 20, if different from Report)		15. SECURITY CLASS. (of this report) UNCLASSIFIED
18. SUPPLEMENTARY NOTES		15a. DECLASSIFICATION/DOWNGRADING SCHEDULE
19. KEY WORDS (Continue on reverse side if necessary and identify by block number) Speckle Interferometry Fibered Composite Structures Young's Fringes Interferogram Elasticity Constants		12) 158p.
20. ABSTRACT (Continue on reverse side if necessary and identify by block number) The objective of this work is to determine elastic constants for composite cylindrical specimens with and without flaws. Speckle interferometry was used to measure the displacements of 30 fiber reinforced, thin wall, composite pressure vessels. Small simulated spot flaws were introduced in 12 of the cylinders while 18 had no flaws. A mathematical and geometrical development is presented to determine the modulus of elasticity and Poisson's ratio for the composite cylinders. The test setup and procedure for preparing interferograms ABSTRACT (Continued)		

DD FORM 1 JAN 73 1473 EDITION OF 1 NOV 65 IS OBSOLETE

UNCLASSIFIED

SECURITY CLASSIFICATION OF THIS PAGE (When Data Entered)

393 427

LB

UNCLASSIFIED

SECURITY CLASSIFICATION OF THIS PAGE(When Data Entered)

ABSTRACT (Concluded)

is described. The technique of speckle interferometric analysis using Young's Fringes is presented. A computer aided data reduction system used to analyze the interferograms is described. Plots were made of displacements versus scan points for the flawed and unflawed cylinders. The spot flaws were not detected from the displacement data. Circumferential stress, circumferential strain, axial strain, modulus of elasticity and Poisson's ratio were computed. Means and standard deviations of the elasticity constants were computed. This report presents a valid and efficient technique to determine elasticity constants using speckle interferometry.

UNCLASSIFIED

SECURITY CLASSIFICATION OF THIS PAGE(When Data Entered)

LIST OF SYMBOLS

C	Outside circumference of cylinder
D	Spacing between fringes
E	Modulus of elasticity
f	Distance from interferogram to analyzer screen
m	Fringe order
P	Internal pressure
R	Mean radius
S	Film scale factor
t	Cylinder wall thickness
U1	Displacement in circumferential direction
U2	Displacement in axial direction
δ_i	Difference function
δ_R	Displacement of outer surface of cylinder in the radial direction
$\epsilon_\theta, \epsilon_r$	Strains in the circumferential and axial directions
θ, z, r	Coordinate system shown in Figure 1
λ	Wavelength of laser light
ν	Poisson's ratio
$\sigma_e, \sigma_r, \sigma_z$	Stress components

ADMISSION NO.	
OTIS	Write Station <input checked="" type="checkbox"/>
SOC	Duty Station <input type="checkbox"/>
UNASSIGNED	<input type="checkbox"/>
JUSTIFICATION	
BY	
ORIENTATION/AVAILABILITY CODES	
Reg.	AVAIL. NO./OR SPECIAL
A	P E S

CONTENTS

	Page
I. INTRODUCTION	3
II. ANALYTICAL CONSIDERATIONS	4
A. Elasticity Constants	4
B. Displacement Determination	9
III. EXPERIMENTAL CONSIDERATIONS	10
A. Composite Material Selection and Manufacture	10
B. Test Specimen Preparation	12
C. Test Setup and Procedure	12
IV. DATA ANALYSIS	16
A. Speckle Interferometric Analysis Using Young's Fringes	16
B. Data Collection System	16
V. RESULTS AND DISCUSSION	19
VI. SUMMARY AND CONCLUSIONS	20
REFERENCES	49
Appendix A. INPUT DATA USED TO CALCULATE ELASTICITY CONSTANTS	51
Appendix B. COMPUTER CODES	148

CONTENTS

ACKNOWLEDGMENTS

The author hereby expresses his sincere gratitude and deep appreciation to Mr. J. A. Schaeffel for his guidance on speckle interferometry and the computer aided data reduction system, Mr. O. C. Fruchtnicht for making the fiber reinforced composite cylinders, and Mr. R. B. McGowan and Ms. A. F. Strickland for their assistance with the laboratory work and data reduction.

I. INTRODUCTION

An increasing demand for new materials has prompted the use of composites for such applications as rocket motor cases and launch tubes. Filament-wrapped composite structures have merit because of the high strength to weight ratio, low cost of manufacturing, and the feasibility of high rate of production automation. With the increasing use of composites for structural applications there exists a need for composite material elasticity constants such as the modulus of elasticity and Poisson's ratio. These constants are of paramount importance in the area of engineering design and structural analysis. Because of the nonhomogeneity of composite structures, different techniques of analyzation must be used. One objective of this task was to devise a valid and efficient technique to determine elasticity constants for hollow composite cylindrical pressure vessels.

A need also exists for the detection and evaluation of flaws inadvertently introduced into composite structures through automated manufacturing processes. In a high speed operation, the flaws likely to occur in a fiberglass roving composite system are debonds because of the introduction of grease, oil, water, air bubbles, and other contaminants. Another likely flaw would be an absence of resin causing debond because of a lack of adhesion. Such conditions of unbonded areas in composite structures are likely to occur occasionally in a mass production type operation.

Another objective of this work was to determine the magnitude of surface displacements and strains of hollow cylindrical pressure vessels in the area of flaw simulations. In a manufacturing operation the process could be used to detect flaws, assess their significance and decide whether the composite structure should be accepted or rejected.

The twofold objective of determining elasticity constants and flaw detection was investigated using the optical process of speckle interferometry to measure surface displacements. Some conventional methods of measuring surface strain and displacement utilize strain gauges, dial gauges and various other mechanical and electrical sensing devices. Such methods are highly accurate and sensitive; however, information is given over limited regions only, as discussed in Leendertz [1]. Therefore a full field view of the strain or displacement distribution requires a large number of measurements at different locations and is very time consuming. Speckle interferometry is a technique which provides a sensitive, noncontact method of measuring the in-plane components of displacement from the full field point of view in an efficient manner.

In the analytical considerations portion of this report a mathematical and geometrical formulation is presented to calculate a composite modulus of elasticity and Poisson's ratio based on the displacement data obtained through speckle interferometry. Also included is a statistical look at the results of the elasticity constants.

Section III discusses the type of composite materials used as well as the experimental testing arrangement while Section IV discusses speckle interferometric analysis using Young's fringes and the data collection system. Appendix A contains a record of input data used for the determination of elasticity constants and Appendix B contains a description of the computer codes used in analyzing the data.

II. ANALYTICAL CONSIDERATIONS

A. Elasticity Constants

The stress-strain relationships as derived in Shaw and Smith [2] were used as a basis to develop the equations to calculate the composite modulus of elasticity and Poisson's ratio. The composite test specimens were treated as free end, thin wall, cylindrical pressure vessels with a geometry as shown in Figure 1. The test cylinders were treated as free end because the ends were closed and allowed to float freely on rubber O-rings which did not restrict the deformation in any way.

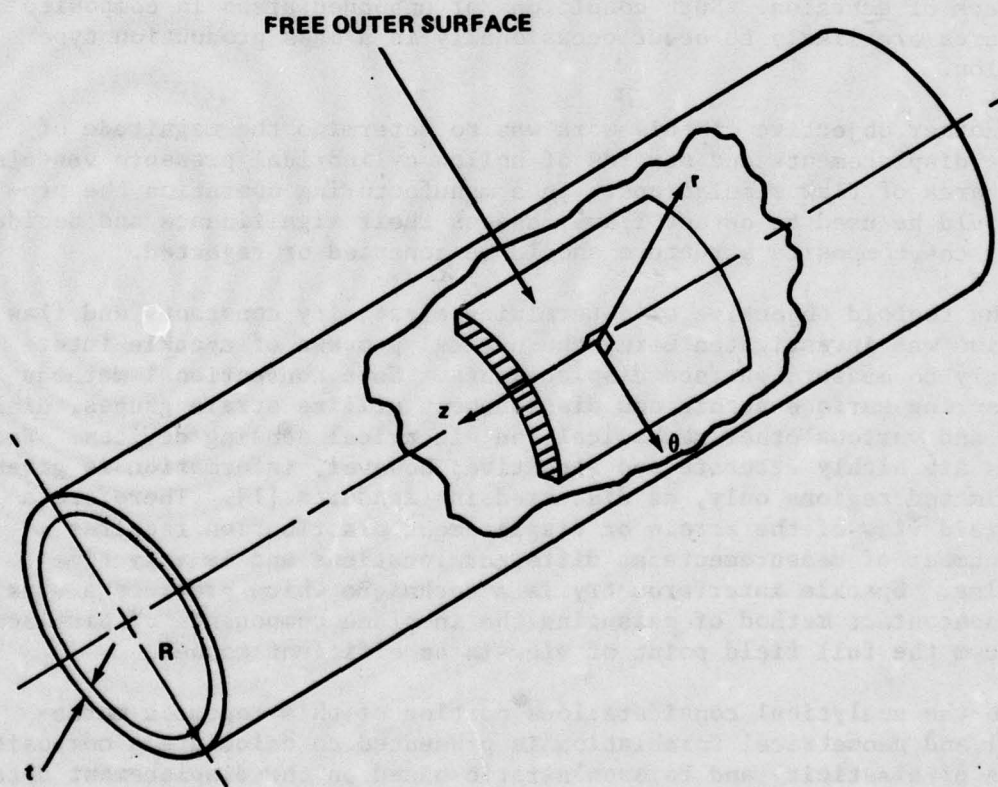

Figure 1. Geometry for stress-strain relationships.

The stress component in the circumferential direction is calculated using

$$\sigma_{\theta} = \frac{PR}{t} \quad (1)$$

where P is the internal pressure, t is the wall thickness, and R is the mean radius measured from the center of the cylinder to the middle of the wall thickness. The stress component in the radial direction on the internal wall is

$$\sigma_r = -P$$

and on the external wall is

$$\sigma_r = 0$$

The force caused by the internal pressure in the axial direction is exerted on the end caps and not the pressure vessel so that

$$\sigma_z = 0$$

The strain components in the circumferential and axial directions, respectively, are

$$\epsilon_{\theta} = \left(\frac{1}{E}\right) \sigma_{\theta} \quad (2)$$

$$\epsilon_r = -\left(\frac{\nu}{E}\right) \sigma_{\theta} \quad (3)$$

where E is the modulus of elasticity and ν is Poisson's ratio.

The modulus of elasticity can be obtained from Equation (2) yielding

$$E = \frac{\sigma_{\theta}}{\epsilon_{\theta}} \quad (4)$$

Solving Equation (3) for ν and substituting Equation (4) yields Poisson's ratio

$$\nu = -\frac{\epsilon_r}{\epsilon_{\theta}} \quad (5)$$

A least squares polynomial approximation for discrete data was used to calculate ϵ_r , the strain in the axial direction. Given a polynomial, in this case a straight line equation

$$Y = a_1 X + a_2 = Y(X)$$

and solve for $a_1 = \epsilon_r$. Applying the difference function fields

$$\delta_i = Y_i - Y(X_i) = Y_i - (a_1 X_i + a_2)$$

Then taking the square of the difference function yields

$$\Sigma \delta_i^2 = \Sigma (Y_i - a_1 X_i - a_2)^2$$

Setting the partial derivatives of the difference function to zero

$$\frac{\partial \Sigma \delta_i^2}{\partial a_1} = 2 \Sigma - X_i Y_i + a_1 X_i^2 + a_2 X_i = 0 \quad (6)$$

$$\frac{\partial \Sigma \delta_i^2}{\partial a_2} = 2 \Sigma - Y_i + a_1 X_i + a_2 = 0 \quad (7)$$

Reducing Equations (6) and (7) and applying Cramer's Rule one can solve for $a_1 = \epsilon_r$

$$\epsilon_r = \frac{(\Sigma Y_i X_i) N - \Sigma X_i Y_i}{(\Sigma X_i^2) N - \Sigma X_i \Sigma X_i} \quad (8)$$

The input datum X_i is the number of vertical scan points of the 40° scan where input datum Y_i is the corresponding displacement in the axial direction. Figure 2 shows how the 0°, 40°, and 80° scans were oriented on the cylinder.

Determination of ϵ_θ , the strain in the circumferential direction, was obtained using displacement data from the 0° and 80° scan lines. Figure 3 shows the geometry used to obtain ϵ_θ . When viewed along the line of vision, U1 displacement data from the 0° and 80° scan lines are obtained by a computer aided laser scanning technique described in the data analysis portion of this report [3]. The circumferential strain for the deformed cylinder shown in Figure 3 is

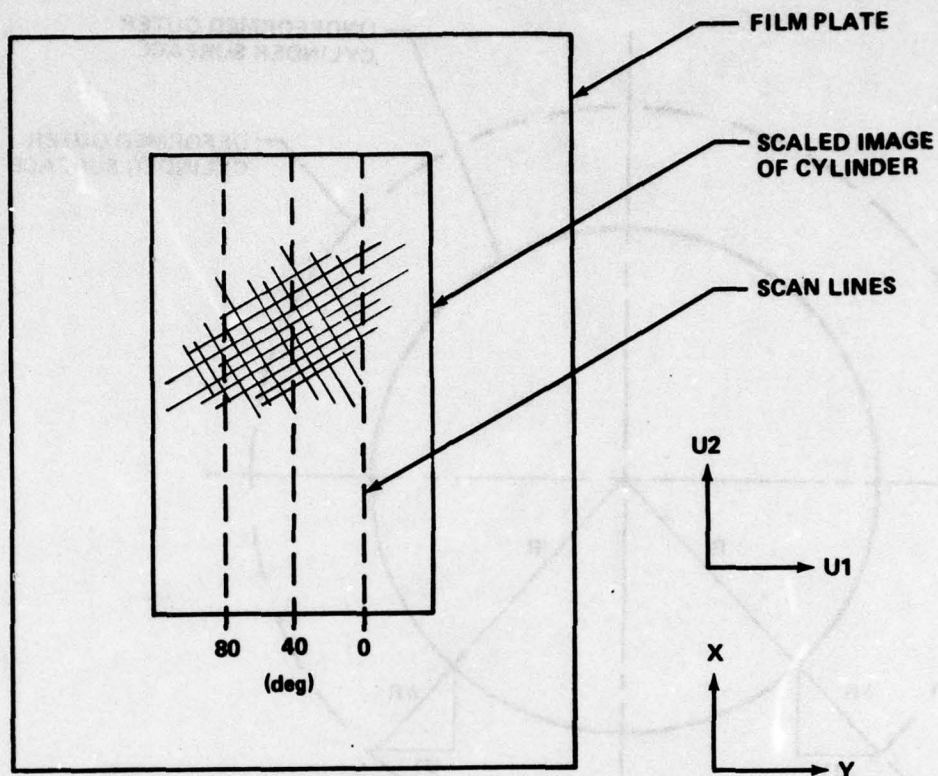

Figure 2. Interferogram showing scan lines representing angles of 40° separation.

$$\epsilon_{\theta} = \frac{C_{\text{final}} - C_{\text{initial}}}{C_{\text{initial}}}$$

where C_{final} is the circumference of the deformed cylinder and C_{initial} is the circumference of the cylinder in its unloaded state. The above equation reduces to

$$\epsilon_{\theta} = \frac{\delta R}{R} \quad (9)$$

where R is the outside radius of the undeformed cylinder and δR is the displacement of the outer surface in the radial direction that occurs when the cylinder is pressurized. Solving for δR gives

$$\delta R = \frac{U1}{\text{SINE } 40^{\circ}}$$

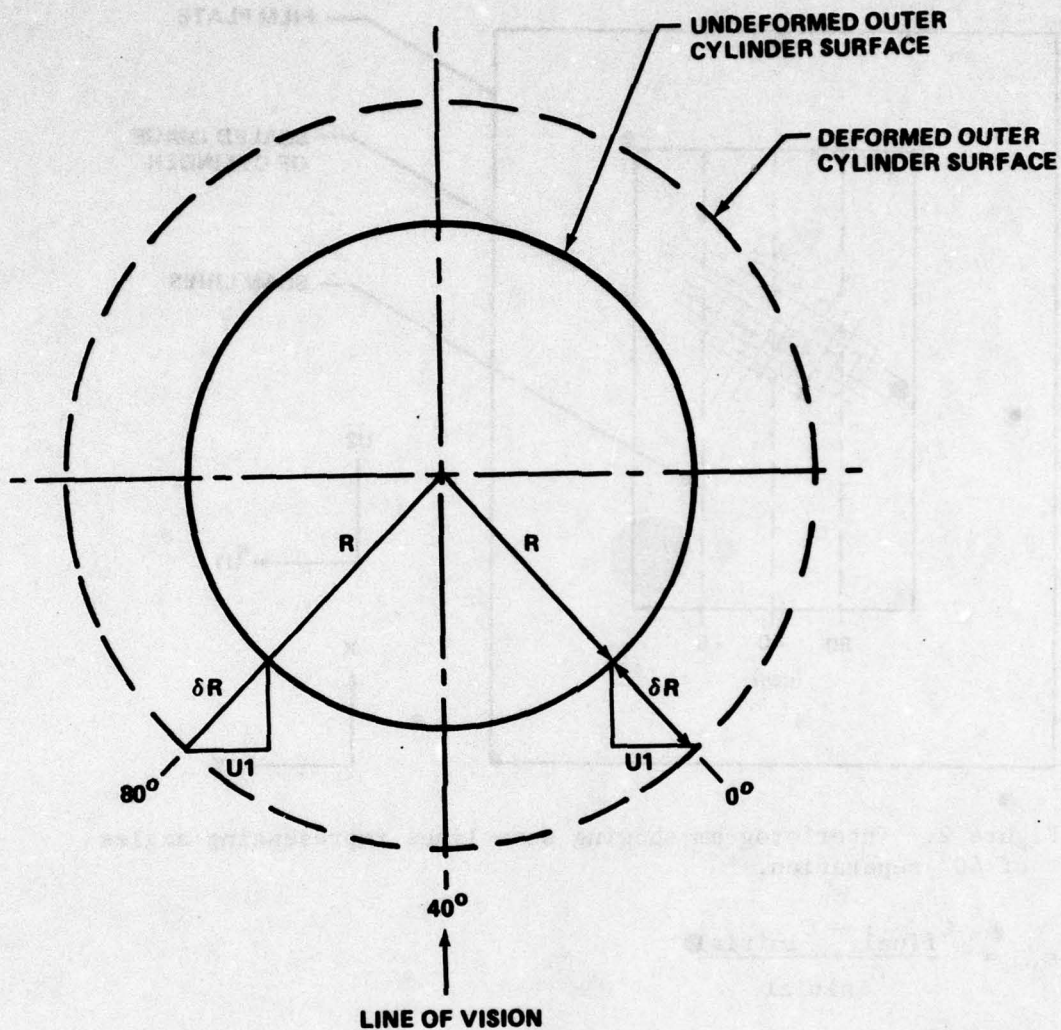

Figure 3. Geometry used to determine circumferential strain.

which is required to solve Equation (9). A computer program was written to perform the least squares fit and calculate the composite modulus of elasticity and Poisson's ratio requiring only the speckle displacements as inputs. The program appears in Appendix B.

The mean standard deviation was used to measure variation of the composite modulus of elasticity and Poisson's ratio for the composite cylinders at different wrap angles:

$$\text{Standard Deviation (SD)} = \sqrt{\frac{\sum_{i=1}^N (X_i - \bar{X})^2}{N - 1}} \quad (10)$$

where X_1 = Individual values of X inputs

\bar{X} = Arithmetic mean of inputs

N = Total number of inputs in sample.

The computer program written to calculate the standard deviation appears in Appendix B.

B. Displacement Determination

A computer aided laser scanning technique [3] as described in the data analysis section of this report was utilized to analyze the interferograms as shown in Figure 2. The interferogram was housed in an X-Y translation table equipped with stepping motors and controlled by a computer program. Figure 4 shows the basic scanning setup of the translation table used to project interference fringes onto a diffusion screen. The interferogram was scanned in the X direction at 0°, 40°, and 80° scan lines. The fringe spacing and angle of orientation were entered into the computer which calculated the displacement component from

$$U = \frac{m\lambda f S}{D} \quad (11)$$

where U = In-plane displacement at a point between loaded and unloaded model

m = Fringe order

D = Spacing between fringes

λ = Wavelength of laser light used in data analysis

f = Distance from interferogram to analyzer screen

S = Film Scale factor

and resolved the component into the X and Y directions which correspond to circumferential and axial displacements. The complete development of Equation (11) is presented in Mullinix [4]. The wavelength of the HeNe laser light is 6328 Å. The film scale factor, S, is found by dividing the true length of the illuminated cylinder by the image length on the interferogram.

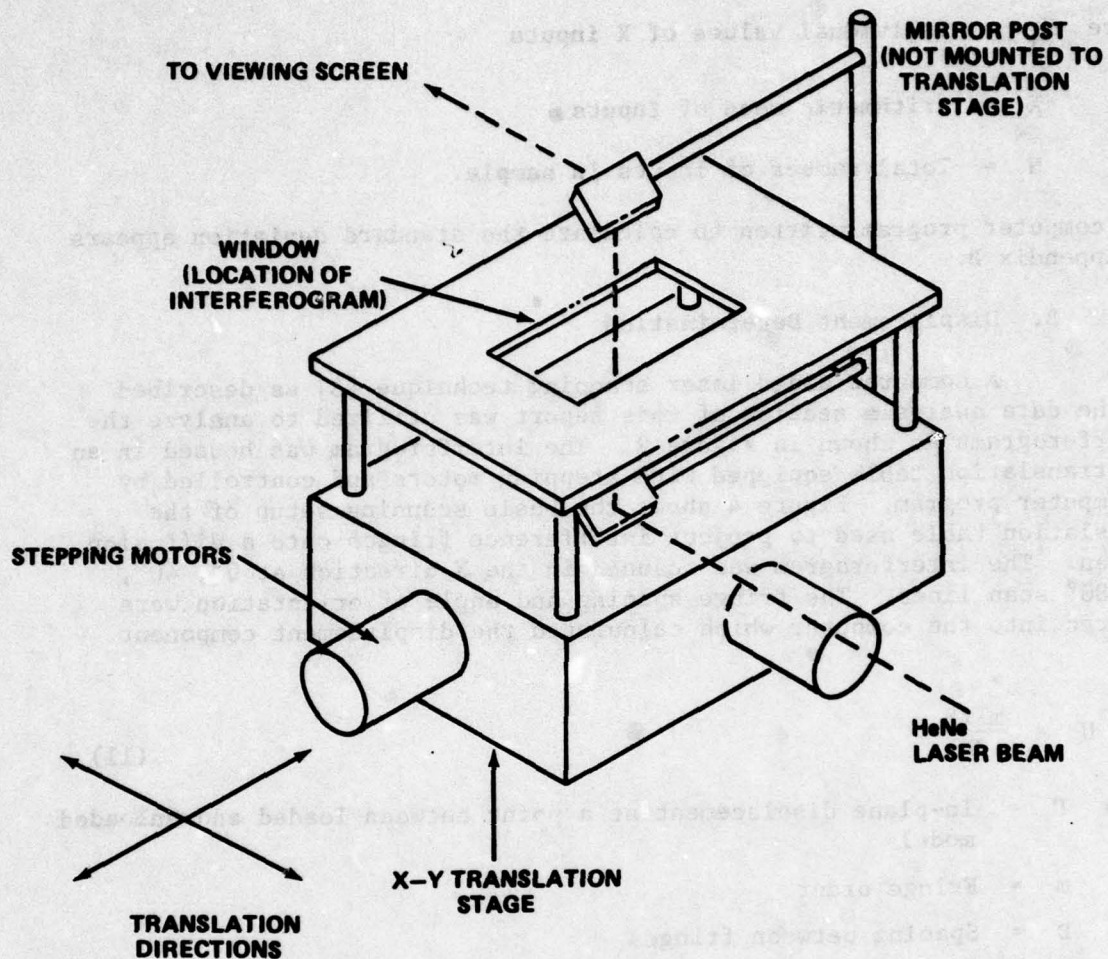

Figure 4. Translation table and laser beam path.

III. EXPERIMENTAL CONSIDERATIONS

A. Composite Material Selection and Manufacture

Thirty thin wall fiberglass reinforced composite cylinders were manufactured to be used in developing nondestructive experimental techniques for determining elasticity constants for composite tubes. The composite cylinders were fabricated by a filament winding process where a continuous bundle of fibers is wetted with epoxy and wound onto a cylindrical mandrel. Three groups of ten structures per group were prepared. Each group had a different helical wrap angle, either $\pm 30^\circ$,

$\pm 45^\circ$ or $\pm 60^\circ$. Each group of ten structures consisted of six unflawed cylinders and four flawed cylinders. The simulated flaws in the cylinders were created by placing a 0.20-in. diameter \times 0.003-in. thick disc of Teflon tape between two helical wraps of filaments located in the center of the wall of the hollow cylinder. The Teflon discs were inserted to inhibit bonding of the helical layers with the resin, thus allowing movement of the layers relative to each other. Different wrap angles were used to compare the effects that each wrap angle configuration has on displacements under various loads. Figure 5 shows the simulated spot flaws, wrap angle, and basic dimensions of the composite cylinders.

The composite structures were manufactured from E glass, type 801 AB, G filament, 12 end roving. The resin system consisted of Epon 828 completed with NMA hardener and BDMA accelerator. Oven cure time was 7 hr at 200°F and 16 hr at 400°F .

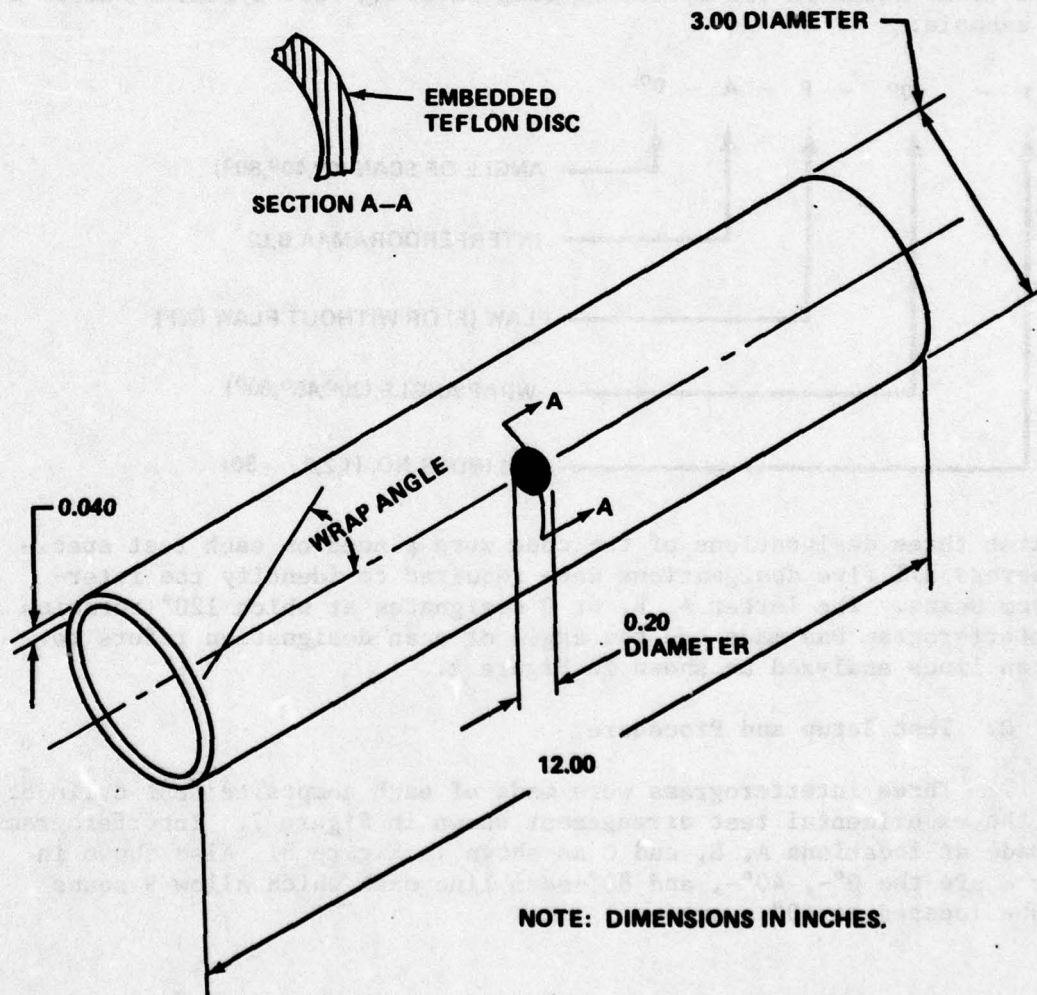
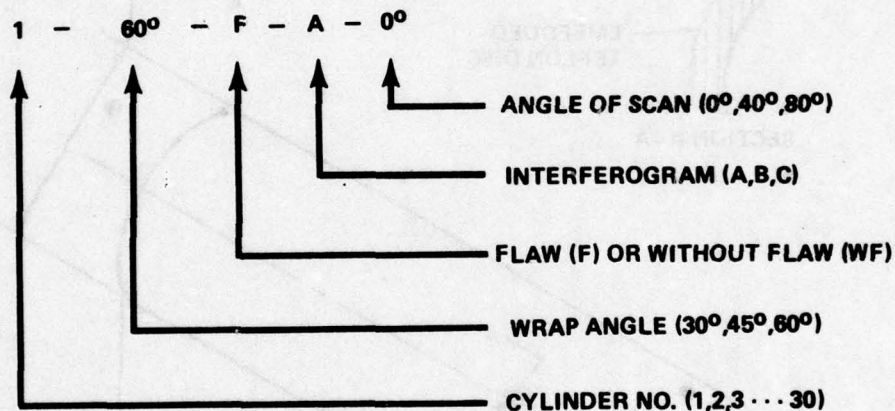

Figure 5. Composite cylinder with simulated spot flaw.

B. Test Specimen Preparation

The fiberglass composite cylinders were received in approximately 35-in. lengths. Two 12-in. long test specimens were cut from each cylinder. The extreme ends of the 35-in. long tubes were avoided because of the nonuniformity of cylinder wall thickness. A 9-in. region on each test specimen was painted with flat white paint to provide a good illuminable surface required for speckle interferometry. Each specimen received 3 rotation markers 120° apart located at the bottom of the test cylinders and a nomenclature code located at the top. Figure 6 shows a typical test specimen prepared for loading and photographing. When placing the 120° rotation markers, care was taken to axially align one of the markers with the test flaw to know the orientation of the flaw when making the interferograms. The alignment was done using a light table to locate the embedded Teflon disc. The test nomenclature code was set up as shown in the following diagram using test cylinder Number 1 as an example:



The first three designations of the code were placed on each test specimen whereas all five designations were required to identify the interferogram scans. The letter A, B, or C designates at which 120° rotation the interferogram was made and the angle of scan designation refers to the scan lines analyzed as shown in Figure 2.

C. Test Setup and Procedure

Three interferograms were made of each composite test cylinder using the experimental test arrangement shown in Figure 7. Interferograms were made at locations A, B, and C as shown in Figure 8. Also shown in Figure 8 are the 0°-, 40°-, and 80°-scan line axes which allow 9 scans per tube located at 40° apart.

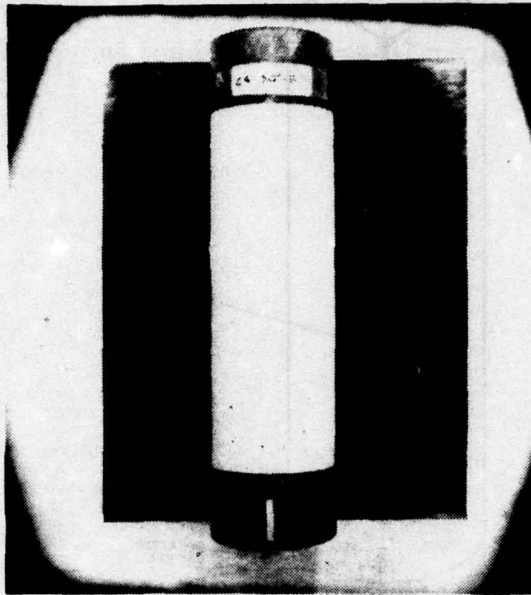

Figure 6. Typical composite test cylinder.

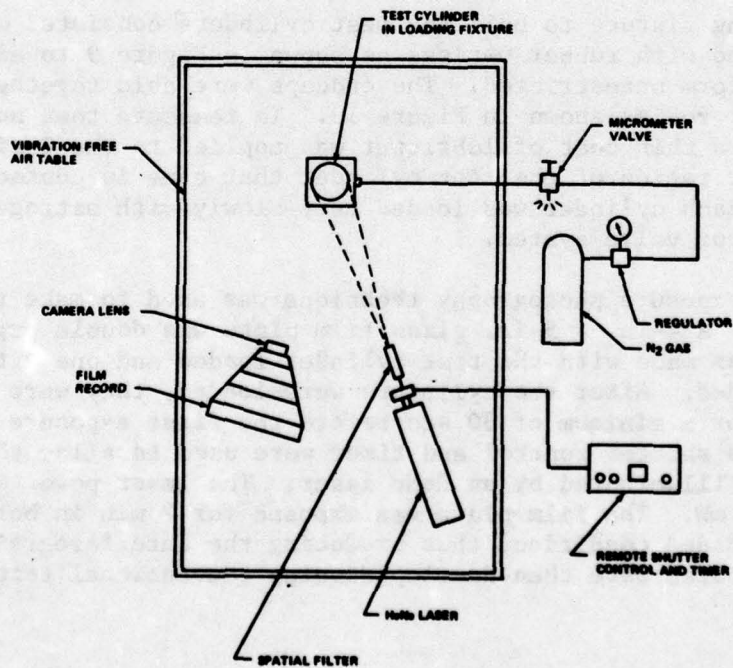

Figure 7. Experimental test arrangement.

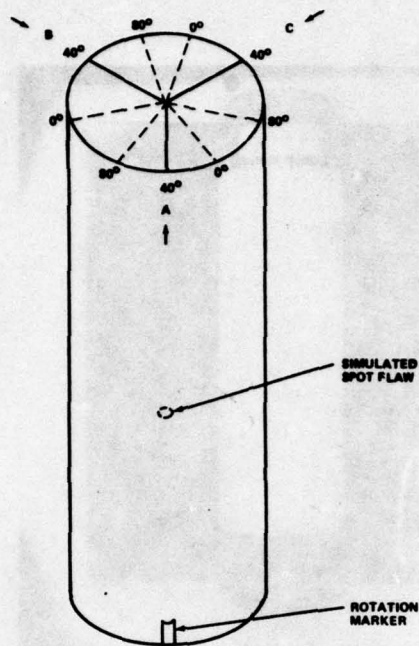

Figure 8. Orientation of composite cylinder for photography.

The loading fixture to hold the test cylinders consisted of two endcaps equipped with rubber O-rings as shown in Figure 9 to allow the cylinder to deform unrestricted. The endcaps were held together with a threaded center rod as shown in Figure 10. To reassure that no restriction occurred, a thin coat of lubricant was applied to the O-rings and to the interior region of the test cylinder that came in contact with the O-rings. Each cylinder was loaded very slowly with nitrogen gas by using a regulator valve system.

A double exposure photography technique was used to make the interferogram. A 4-in. \times 5-in. glass film plate was double exposed: One exposure was made with the test cylinder loaded and one with the cylinder unloaded. After the cylinders were loaded, they were allowed to stabilize for a minimum of 30 sec before the first exposure was made. A remote shutter control and timer were used to allow the test specimen to be illuminated by an HeNe laser. The laser power was adjusted at 70 mW. The film plate was exposed for 2 min in both the loaded and unloaded conditions thus producing the interferogram. The exposed film plates were then developed using conventional techniques.

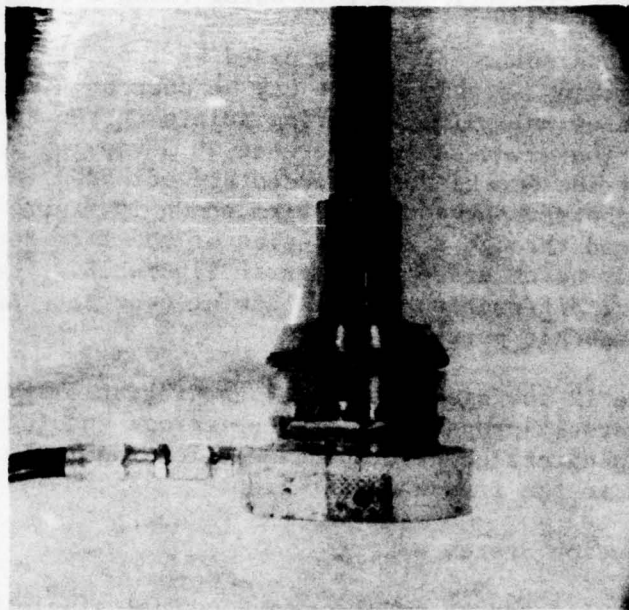

Figure 9. Loading fixture endcap with O-rings.

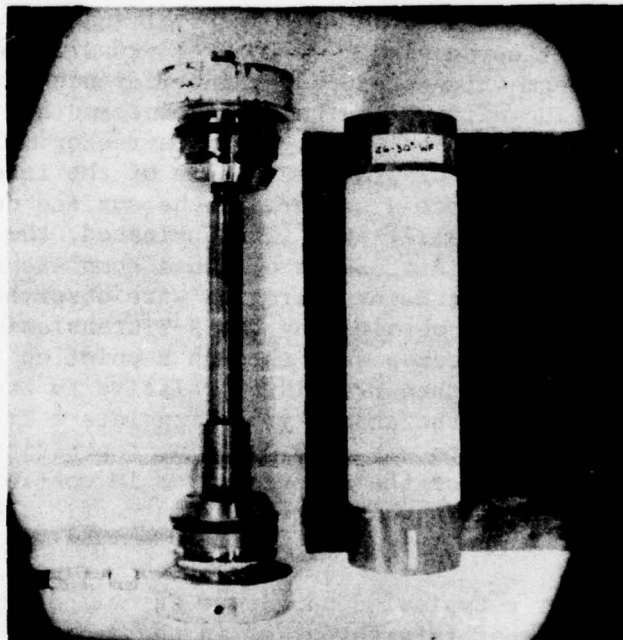

Figure 10. Loading fixture.

IV. DATA ANALYSIS

A. Speckle Interferometric Analysis Using Young's Fringes

When a diffuse surface is illuminated by the coherent radiation from a laser, a grainy speckle effect may be seen on the surface. This effect is because of multiple scattering points on the surface whose random phase distribution produces interference in a viewing plane. A film record is made of the speckle of a loaded and unloaded test cylinder by a double exposure photography configuration shown in Figure 11. When coherent light is passed through a small region of the film record, a diffraction pattern may be observed as shown in Figure 12. These fringes are the result of light diffraction as the beam of coherent light passes through the recorded speckle pattern.

As seen in Figure 12 the displacement of the region illuminated by the laser beam is inversely proportional to the fringe spacing as given by Equation (11). The direction of displacement for the region is along an axis perpendicular to the fringe orientation.

B. Data Collection System

The data were collected by an electromechanical single beam speckle interferometric analyzer system as shown in Figure 13. The computer aided data reduction system was developed primarily for applications in speckle interferometric data analysis [3]. The basic system consists of two parts which include an optical display of interference data and the computer hardware used in the numerical analysis. The interferogram was placed in a viewing window of the X-Y translation table and illuminated by a laser beam which produced an interference fringe pattern as shown in Figure 14. The diffraction halo was centered and viewed on a diffuser screen which included a 10-in., 360° protractor. The protractor was used to measure the displacement angle of the interference fringes. Interference fringes are a measure of the surface deformation of the test cylinder. Since a small area is illuminated, the information yields the displacement at a point. So to obtain a complete description of the surface, many points on the interferogram were observed. The many points of observation were obtained by the X-Y translation table as shown in Figure 4. The laser beam passes through a point on the interferogram and the film plate is then translated relative to the stationary laser beam. The X-Y stage has the capacity to translate 6 in. in each direction in 0.001-in. increments with a 0.0001-in. repositioning accuracy [3]. Location of a point on the interferogram is controlled by the translation stage stepping motors which are in turn controlled by the computer.

The data obtained for a typical composite test cylinder involved the point by point scanning of interferograms in the X-direction for the three different scan lines shown in Figure 2. The scan points were obtained by the translation table moving a distance of 0.15-in. in the X direction. When multiplied by the film scale factor, S , the true

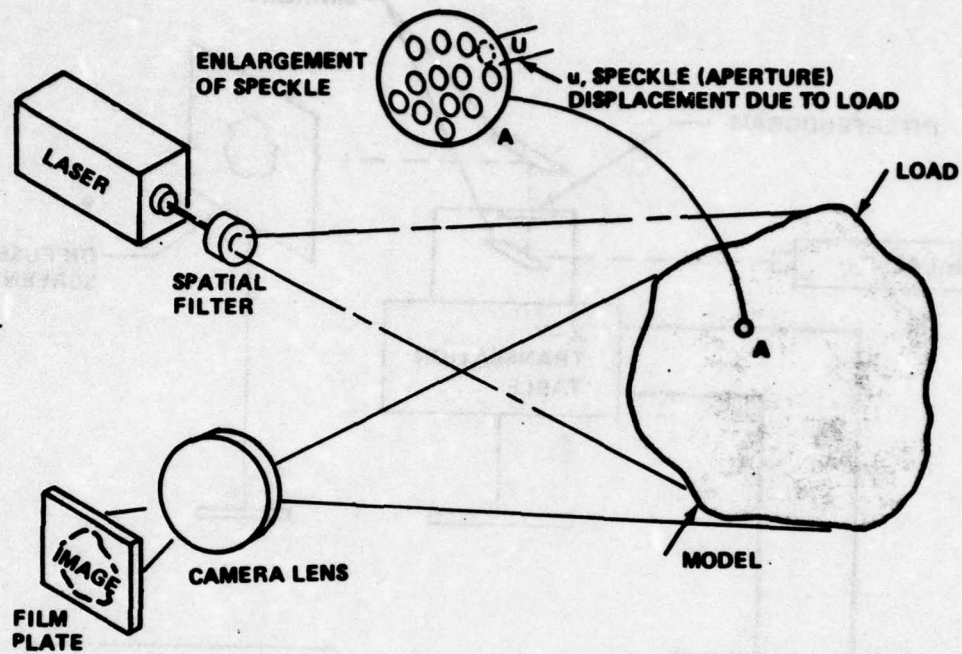

Figure 11. Collection of speckle interferometric data.

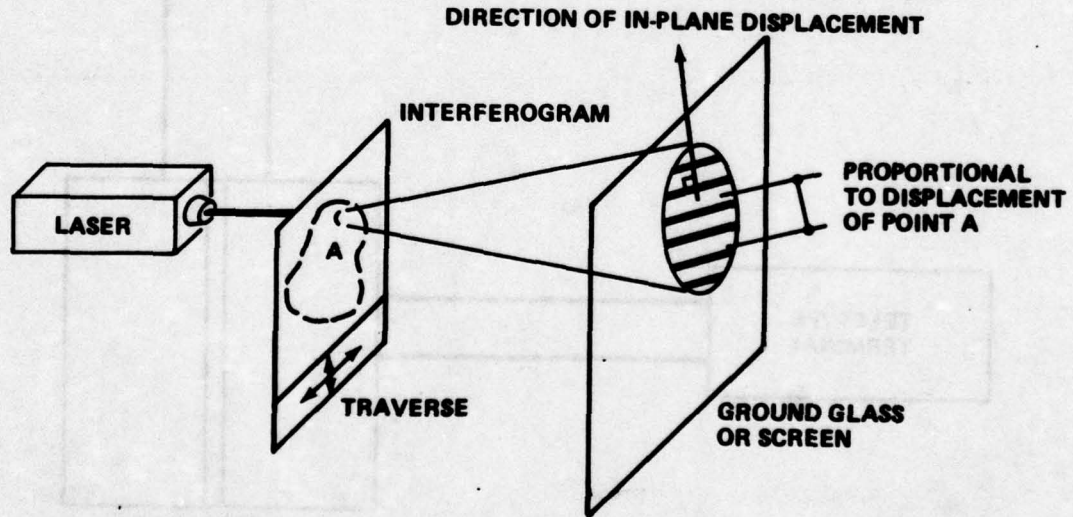

Figure 12. Diffraction Pattern.

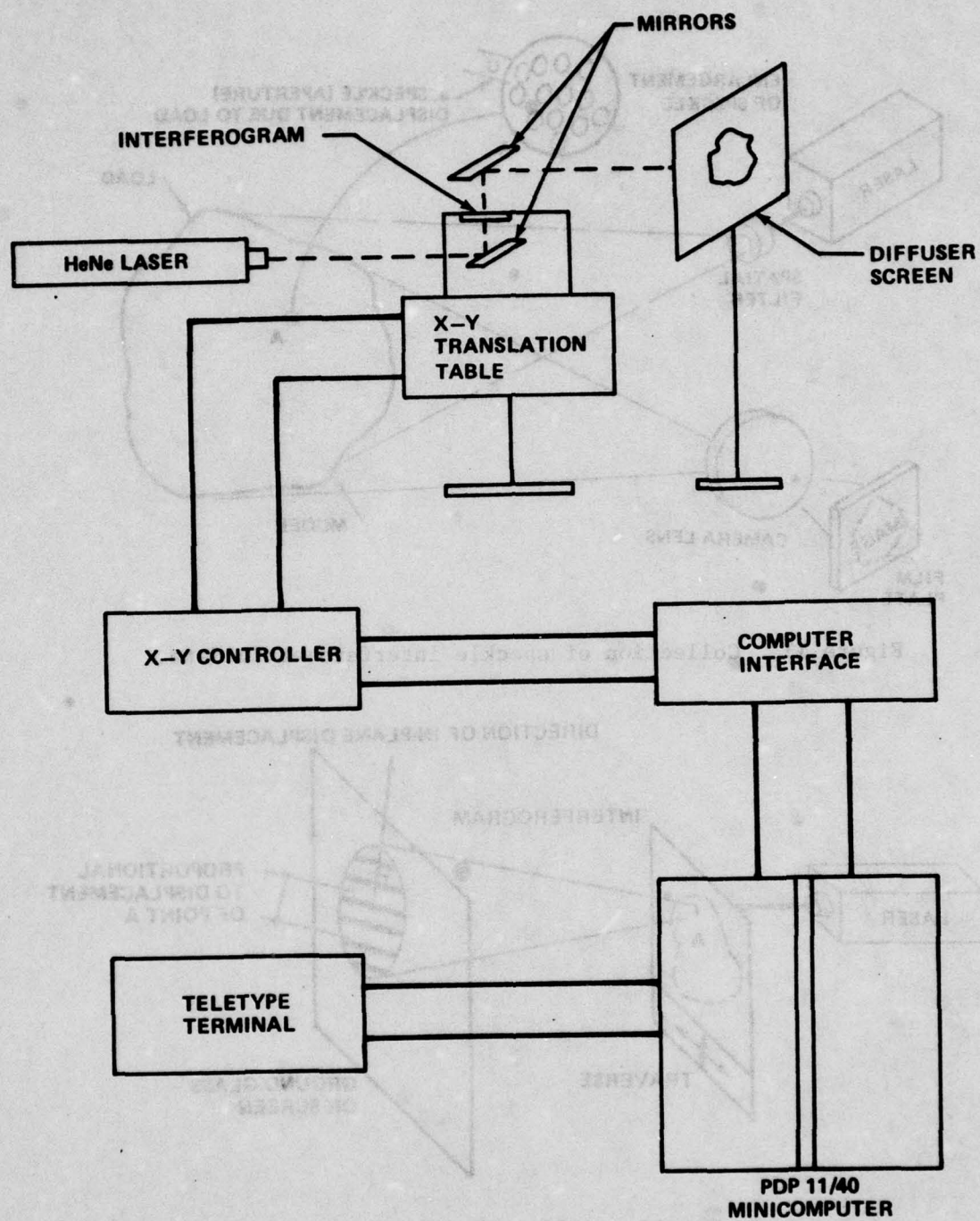

Figure 13. Electromechanical single-beam speckle interferometric analyzer system.

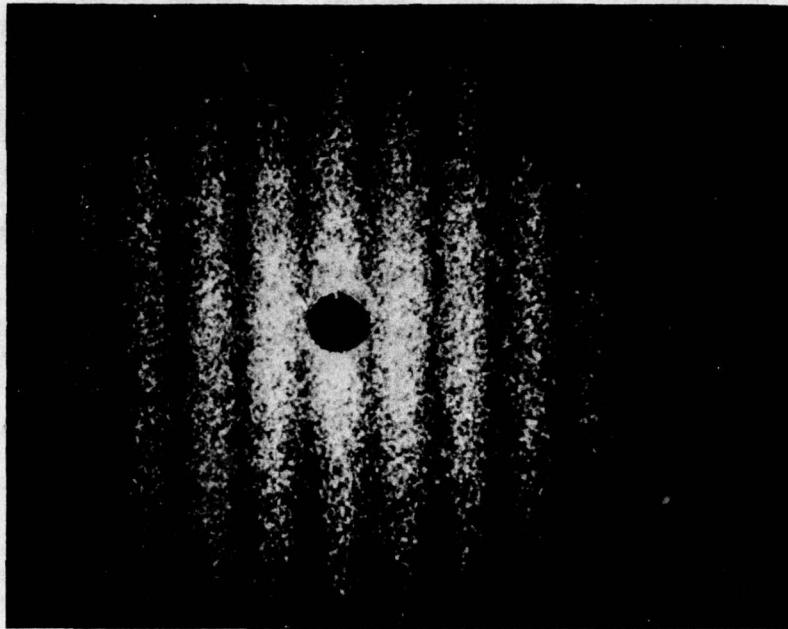

Figure 14. Typical speckle photography fringe pattern.

distance scanned on the cylinder was equal to 0.379 in. For each scan point the fringe spacing and angle of the fringe was entered into the computer. The computer then calculated the surface displacement and resolved the displacement into the axial and transverse directions using Equation (11).

V. RESULTS AND DISCUSSION

Table 1 shows the test nomenclature and the corresponding load pressures used to deform the composite cylinders. The interferograms were made by double exposing a film plate using the pressures listed in Table 1 for the first exposure and zero cylinder pressure for the second exposure. The pressures listed in Table 1 are well below those pressures that produce crazing of the composite cylinders.

Figures 15 through 32 are representative plots of the displacement data received from the different scans of the composite cylinders. The graphs show both the U1 transverse and U2 axial displacements along the scan line of the cylinder. Note the linearity of the axial displacements as presented in Figures 18, 19, 30, and 31 which represent the 40° scan lines. The results of a least-squares polynomial curve fit [Equation (8)] were used on these data to calculate the axial strain. Some representative circumferential displacement data used for calculation of the circumferential strain appear in Figures 20, 26, and 32 which represent either 0° or 80° scan lines.

A complete listing of the displacements used as input data in the calculations of the elasticity constants appears in Appendix A. Appendix A contains 90 sets of data presented on a point by point basis. The data sets specify whether the displacements are circumferential or axial and the respective data scan lines from which the data were taken. The circumferential stress, circumferential strain, and axial strain are listed in Table 2. These values were used to compute the modulus of elasticity and Poisson's ratio for different wrap angles. The results are listed in Tables 3, 4, and 5. The computer program used to calculate the elasticity constants appears in Appendix B. The means and standard deviations of the elasticity constants were also calculated with the aid of a computer program as listed in Appendix B. The results are shown in Table 6. Poisson's ratio was less for the flawed region of a flawed cylinder than for the unflawed region of a flawed cylinder for all three wrap angles. The largest value of the modulus of elasticity occurs for the $\pm 60^\circ$ -wrap angle cylinders.

The cylinders with the simulated spot flaws did not show a change in the displacements as expected. Figure 15 shows the displacements in the flawed region of a flawed cylinder and Figure 16 shows the displacements in the unflawed region of a flawed cylinder. There is no appreciable difference between the two plots, indicating the flaw did not show up through surface displacements. The flaw was too small to be detected; however, a flaw constructed in same manner but 2.5 times as large in diameter was detected by Mullinix [4] using speckle interferometry.

VI. SUMMARY AND CONCLUSIONS

Speckle interferometry was used to measure surface displacements of 30 fiberglass reinforced composite cylinders from a full field point of view. Small simulated spot flaws consisting of a thin disc of Teflon tape were introduced into 12 of the cylinders while 18 were produced containing no flaws. Three interferograms were made of each cylinder in the loaded and unloaded state. The surface displacements were obtained by analyzing Young's fringes with a computer aided data reduction system. The circumferential and axial displacements versus scan point were plotted to determine if the simulated flaws could be detected. The flaws could not be detected on the plots.

A nondestructive technique was devised to determine the composite modulus of elasticity and Poisson's ratio for the composite cylinders using the displacement data obtained through speckle interferometry. The technique was mathematically and geometrically formulated, treating the composite structures as free end, thin wall, cylindrical pressure vessels. The technique described to measure surface displacements is

TABLE I
TEST CYLINDER LOAD ERRORS

efficient and allows a large number of data points to be analyzed which eliminates data scatter. The foremost advantage of the technique over such conventional methods as strain gauges and dial gauges is that speckle interferometry allows the investigator to obtain full field information rather than data from small regions.

100	10-00-WT-A	170	10-00-WT-A
100	11-00-WT-A	170	11-00-WT-A
100	11-00-WT-B	180	11-00-WT-B
100	11-00-WT-C	180	11-00-WT-C
100	12-00-WT-A	180	12-00-WT-A
100	12-00-WT-B	180	12-00-WT-B
100	12-00-WT-C	180	12-00-WT-C
80	13-00-WT-A	180	13-00-WT-A
80	13-00-WT-B	180	13-00-WT-B
80	13-00-WT-C	180	13-00-WT-C
80	14-00-WT-A	180	14-00-WT-A
80	14-00-WT-B	180	14-00-WT-B
80	14-00-WT-C	180	14-00-WT-C
80	15-00-WT-A	180	15-00-WT-A
80	15-00-WT-B	180	15-00-WT-B
80	15-00-WT-C	180	15-00-WT-C
80	16-00-WT-A	180	16-00-WT-A
80	16-00-WT-B	180	16-00-WT-B
80	16-00-WT-C	180	16-00-WT-C
80	17-00-WT-A	180	17-00-WT-A
80	17-00-WT-B	180	17-00-WT-B
80	17-00-WT-C	180	17-00-WT-C
80	18-00-WT-A	180	18-00-WT-A
80	18-00-WT-B	180	18-00-WT-B
80	18-00-WT-C	180	18-00-WT-C
80	19-00-WT-A	180	19-00-WT-A
80	19-00-WT-B	180	19-00-WT-B
80	19-00-WT-C	180	19-00-WT-C
80	20-00-WT-A	180	20-00-WT-A
80	20-00-WT-B	180	20-00-WT-B
80	20-00-WT-C	180	20-00-WT-C

TABLE 1. TEST CYLINDER LOAD PRESSURE

Test	Load Pressure (psig)	Test	Load Pressure (psig)
1-60°-F-A	150	10-60°-WF-C	150
1-60°-F-B	150	11-45°-F-A	150
1-60°-F-C	150	11-45°-F-B	100
2-60°-F-A	150	11-45°-F-C	100
2-60°-F-B	150	12-45°-F-A	100
2-60°-F-C	150	12-45°-F-B	100
3-60°-F-A	150	12-45°-F-C	100
3-60°-F-B	150	13-45°-F-A	80
3-60°-F-C	150	13-45°-F-B	80
4-60°-F-A	150	13-45°-F-C	80
4-60°-F-B	150	14-45°-F-A	80
4-60°-F-C	150	14-45°-F-B	80
5-60°-WF-A	150	14-45°-F-C	80
5-60°-WF-B	150	15-45°-WF-A	80
5-60°-WF-C	150	15-45°-WF-B	80
6-60°-WF-A	150	15-45°-WF-C	80
6-60°-WF-B	148	16-45°-WF-A	80
6-60°-WF-C	150	16-45°-WF-B	80
7-60°-WF-A	150	16-45°-WF-C	80
7-60°-WF-B	150	17-45°-WF-A	80
7-60°-WF-C	150	17-45°-WF-B	80
8-60°-WF-A	150	17-45°-WF-C	80
8-60°-WF-B	150	18-45°-WF-A	80
8-60°-WF-C	150	18-45°-WF-B	80
9-60°-WF-A	150	18-45°-WF-C	80
9-60°-WF-B	150	19-45°-WF-A	80
9-60°-WF-C	150	19-45°-WF-B	80
10-60°-WF-A	150	19-45°-WF-C	80
10-60°-WF-B	150	20-45°-WF-A	80

TABLE 1. (CONCLUDED)

Test	Load Pressure (psig)	Test	Load Pressure (psig)
20-45°-WF-B	80	25-30°-WF-C	80
20-45°-WF-C	80	26-30°-WF-A	80
21-30°-F-A	60	26-30°-WF-B	80
21-30°-F-B	60	26-30°-WF-C	80
21-30°-F-C	60	27-30°-WF-A	80
22-30°-F-A	60	27-30°-WF-B	80
22-30°-F-B	60	27-30°-WF-C	80
22-30°-F-C	70	28-30°-WF-A	80
23-30°-F-A	60	28-30°-WF-B	80
23-30°-F-B	60	28-30°-WF-C	80
23-30°-F-C	70	29-30°-WF-A	80
24-30°-F-A	80	29-30°-WF-B	80
24-30°-F-B	80	29-30°-WF-C	80
24-30°-F-C	80	30-30°-WF-A	80
25-30°-WF-A	80	30-30°-WF-B	80
25-30°-WF-B	80	30-30°-WF-C	80

TABLE 2. STRESS-STRAINS FOR COMPOSITE TEST CYLINDERS

Cylinder Tested	Circumferential Stress (lb/in. ²)	Circumferential Strain (μ in./in.)	Axial Strain (μ in./in.)
1-60°-F-A	5606	731	368
-B	5606	829	390
-C	5606	883	416
2-60°-F-A	5606	537	369
-B	5606	571	369
-C	5606	548	391
3-60°-F-A	5606	762	276
-B	5606	757	429
-C	5606	720	402
4-60°-F-A	5606	825	397
-B	5606	626	395
-C	5606	667	374
5-60°-WF-A	5606	594	152
-B	5606	643	321
-C	5606	618	347
6-60°-WF-A	5606	677	429
-B	5606	791	391
-C	5606	696	317
7-60°-WF-A	5606	903	356
-B	5606	816	388
-C	5606	842	347
8-60°-WF-A	5606	818	358
-B	5606	877	383
-C	5606	684	402
9-60°-WF-A	5606	915	355
-B	5606	951	339
-C	5606	994	362
10-60°-WF-A	5606	700	276
-B	5606	728	289
-C	5606	730	336
11-45°-F-A	5606	1000	706
-B	3737	599	388
-C	3737	709	414
12-45°-F-A	3737	792	250
-B	3737	692	326
-C	3737	736	323

TABLE 2. (CONTINUED)

Cylinder Tested	Circumferential Stress (lb/in. ²)	Circumferential Strain (μ in./in.)	Axial Strain (μ in./in.)
13-45°-F-A	2990	523	111
-B	2990	633	294
-C	2990	741	333
14-45°-F-A	2990	535	324
-B	2990	542	313
-C	2990	541	289
15-45°-F-A	2990	587	298
-B	2990	523	286
-C	2990	530	281
16-45°-WF-A	2990	517	297
-B	2990	516	322
-C	2990	550	322
17-45°-WF-A	2990	591	345
-B	2990	567	299
-C	2990	597	292
18-45°-WF-A	2990	716	295
-B	2990	581	320
-C	2990	638	301
19-45°-WF-A	2990	723	204
-B	2990	700	257
-C	2990	619	281
20-45°-WF-A	2990	734	294
-B	2990	514	286
-C	2990	346	323
21-30°-F-A	2242	490	118
-B	2242	479	128
-C	2242	466	128
22-30°-F-A	2242	432	93
-B	2242	406	105
-C	2616	543	145
23-30°-F-A	2242	399	100
-B	2242	425	102
-C	2616	481	121
24-30°-F-A	2990	552	154
-B	2990	544	142
-C	2990	568	158

TABLE 2. (CONCLUDED)

Cylinder Tested	Circumferential Stress (lb/in. ²)	Circumferential Strain (μ in./in.)	Axial Strain (μ in./in.)
25-30°-WF-A	2990	539	131
-B	2990	539	141
-C	2990	565	141
26-30°-WF-A	2990	567	148
-B	2990	627	140
-C	2990	604	154
27-30°-WF-A	2990	598	136
-B	2990	547	158
-C	2990	553	152
28-30°-WF-A	2990	517	139
-B	2990	599	161
-C	2990	587	136
29-30°-WF-A	2990	608	146
-B	2990	565	135
-C	2990	529	141
30-30°-WF-A	2990	493	141
-B	2990	587	138
-C	2990	553	142

TABLE 3. ELASTICITY CONSTANTS FOR 60° WRAP ANGLE

Cylinder Tested	Poisson's Ratio	Composite Modulus Of Elasticity (Mpsi)
1-60°-F-A	0.503	7.67
-B	0.470	6.77
-C	0.471	6.35
2-60°-F-A	0.687	10.44
-B	0.647	9.82
-C	0.713	10.23
3-60°-F-A	0.362	7.35
-B	0.566	7.41
-C	0.558	7.80
4-60°-F-A	0.481	6.80
-B	0.631	8.96
-C	0.560	8.40
5-60°-WF-A	0.256	9.44
-B	0.500	8.72
-C	0.561	9.07
6-60°-WF-A	0.634	8.28
-B	0.494	7.00
-C	0.455	8.05
7-60°-WF-A	0.394	6.21
-B	0.476	6.87
-C	0.413	6.66
8-60°-WF-A	0.438	6.85
-B	0.436	6.39
-C	0.588	8.20
9-60°-WF-A	0.388	6.13
-B	0.356	5.90
-C	0.365	5.64
10-60°-WF-A	0.394	8.01
-B	0.397	7.70
-C	0.460	7.68

TABLE 4. ELASTICITY CONSTANTS FOR 45° WRAP ANGLE

Cylinder Tested	Poisson's Ratio	Composite Modulus Of Elasticity (Mpsi)
11-45°-F-A	0.706	5.61
-B	0.647	6.24
-C	0.584	5.27
12-45°-F-A	0.316	4.72
-B	0.472	5.40
-C	0.439	5.08
13-45°-F-A	0.211	5.71
-B	0.465	4.73
-C	0.450	4.03
14-45°-F-A	0.606	5.59
-B	0.578	5.52
-C	0.534	5.53
15-45°-WF-A	0.508	5.10
-B	0.547	5.72
-C	0.531	5.64
16-45°-WF-A	0.574	5.78
-B	0.624	5.80
-C	0.586	5.44
17-45°-WF-A	0.584	5.06
-B	0.528	5.28
-C	0.488	5.01
18-45°-WF-A	0.412	4.18
-B	0.552	5.15
-C	0.472	4.69
19-45°-WF-A	0.282	4.14
-B	0.367	4.27
-C	0.454	4.83
20-45°-WF-A	0.400	4.07
-B	0.556	5.82
-C	0.934	8.65

TABLE 5. ELASTICITY CONSTANTS FOR 30° WRAP ANGLE

Cylinder Tested	Poisson's Ratio	Composite Modulus Of Elasticity (Mpsi)
21-30°-F-A	0.242	4.58
-B	0.267	4.68
-C	0.274	4.81
22-30°-F-A	0.216	5.19
-B	0.258	5.52
-C	0.267	4.82
23-30°-F-A	0.250	5.62
-B	0.240	5.28
-C	0.252	5.44
24-30°-F-A	0.280	5.41
-B	0.262	5.50
-C	0.279	5.27
25-30°-WF-A	0.243	5.54
-B	0.261	5.55
-C	0.250	5.29
26-30°-WF-A	0.260	5.27
-B	0.223	4.77
-C	0.254	4.95
27-30°-WF-A	0.227	5.00
-B	0.289	5.47
-C	0.276	5.40
28-30°-WF-A	0.270	5.79
-B	0.268	4.99
-C	0.232	5.09
29-30°-WF-A	0.241	4.92
-B	0.238	5.29
-C	0.267	5.65
30-30°-WF-A	0.285	6.07
-B	0.236	5.10
-C	0.258	5.41

TABLE 6. MEANS AND STANDARD DEVIATIONS OF ELASTICITY CONSTANTS

Cylinder Nomenclature	Modulus of Elasticity		Poisson's Ratio	
	Mean (Mpsi)	Standard Deviation (Mpsi)	Mean	Standard Deviation
All WF-60°	7.38	1.13	0.445	0.090
All WF-45°	5.26	1.04	0.522	0.135
All WF-30°	5.31	0.34	0.254	0.019
F-A-60°	8.06	1.63	0.508	0.134
F-A-45°	5.41	0.46	0.460	0.234
F-A-30°	5.20	0.45	0.247	0.026
F-B-60°	8.24	1.40	0.579	0.080
F-B-45°	5.47	0.62	0.541	0.088
F-B-30°	5.24	0.39	0.257	0.012
F-C-60°	8.19	1.61	0.576	0.101
F-C-45°	4.98	0.66	0.502	0.070
F-C-30°	5.08	0.32	0.268	0.012
F-B and C-60°	8.22	1.39	0.577	0.084
F-B and C-45°	5.22	0.65	0.521	0.076
F-B and C-30°	5.16	0.34	0.262	0.012

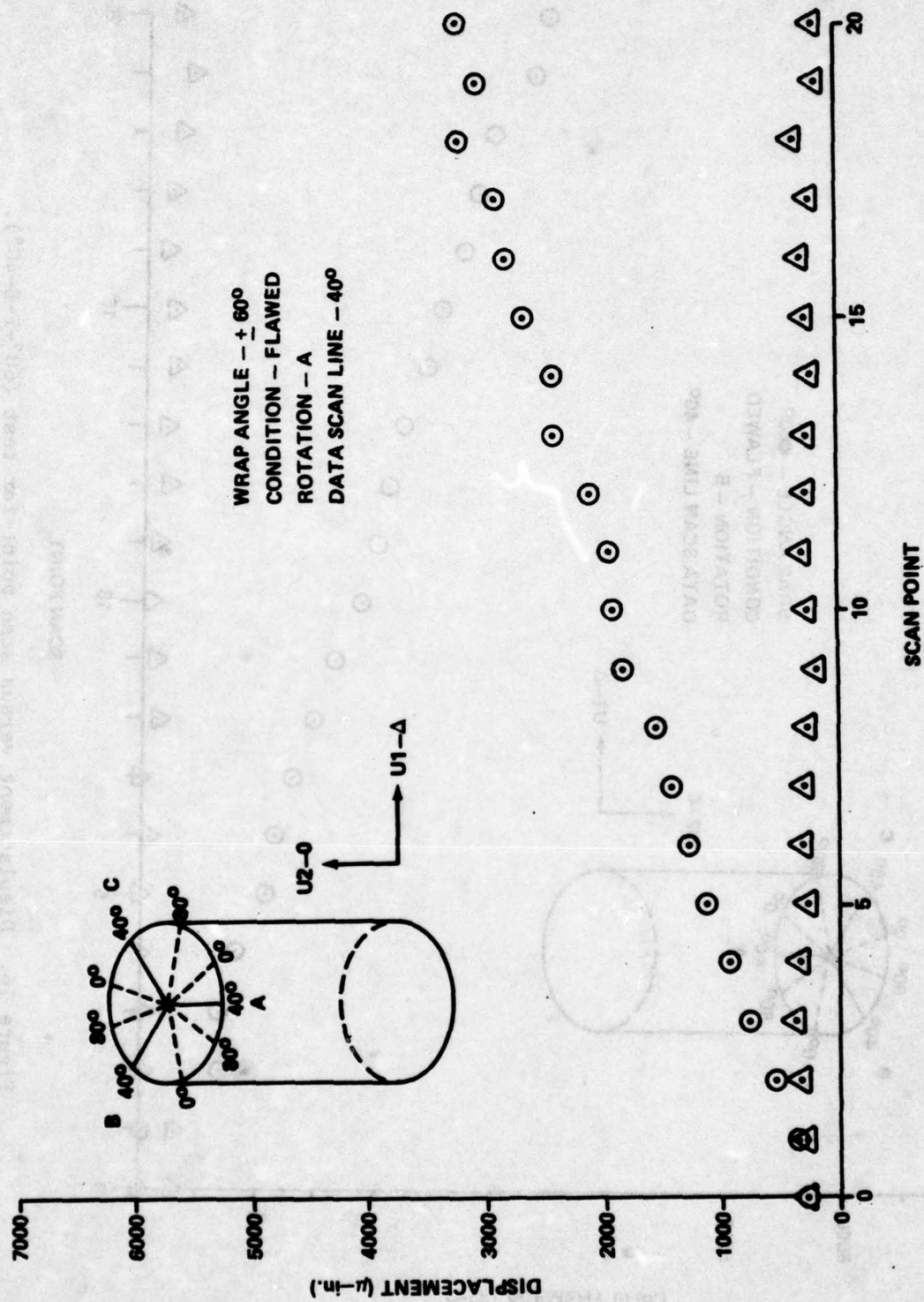

Figure 15. Displacement versus scan point for test (60° -F-A- 40°).

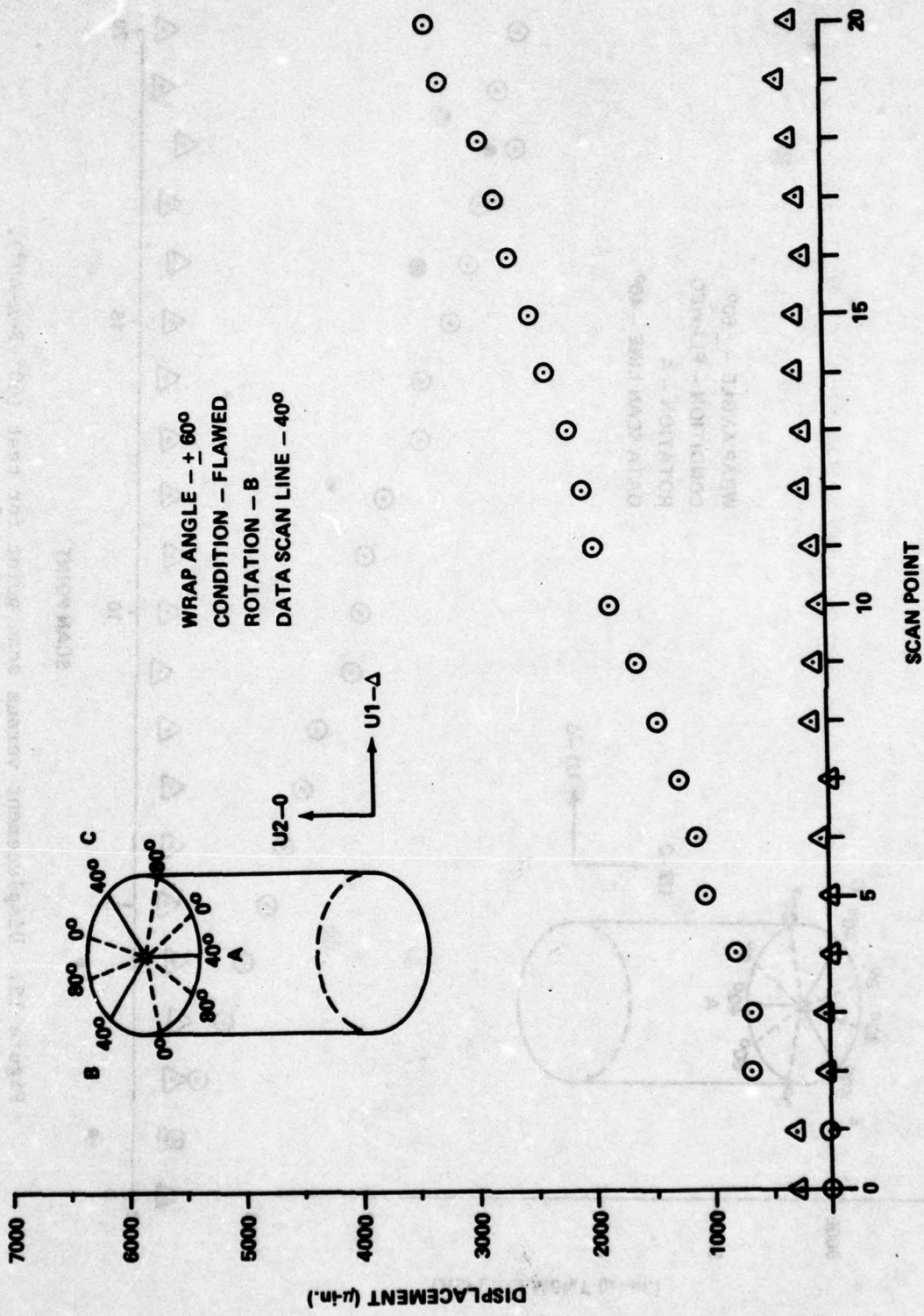

Figure 16. Displacement versus scan point for test (60°-F-B-40°).

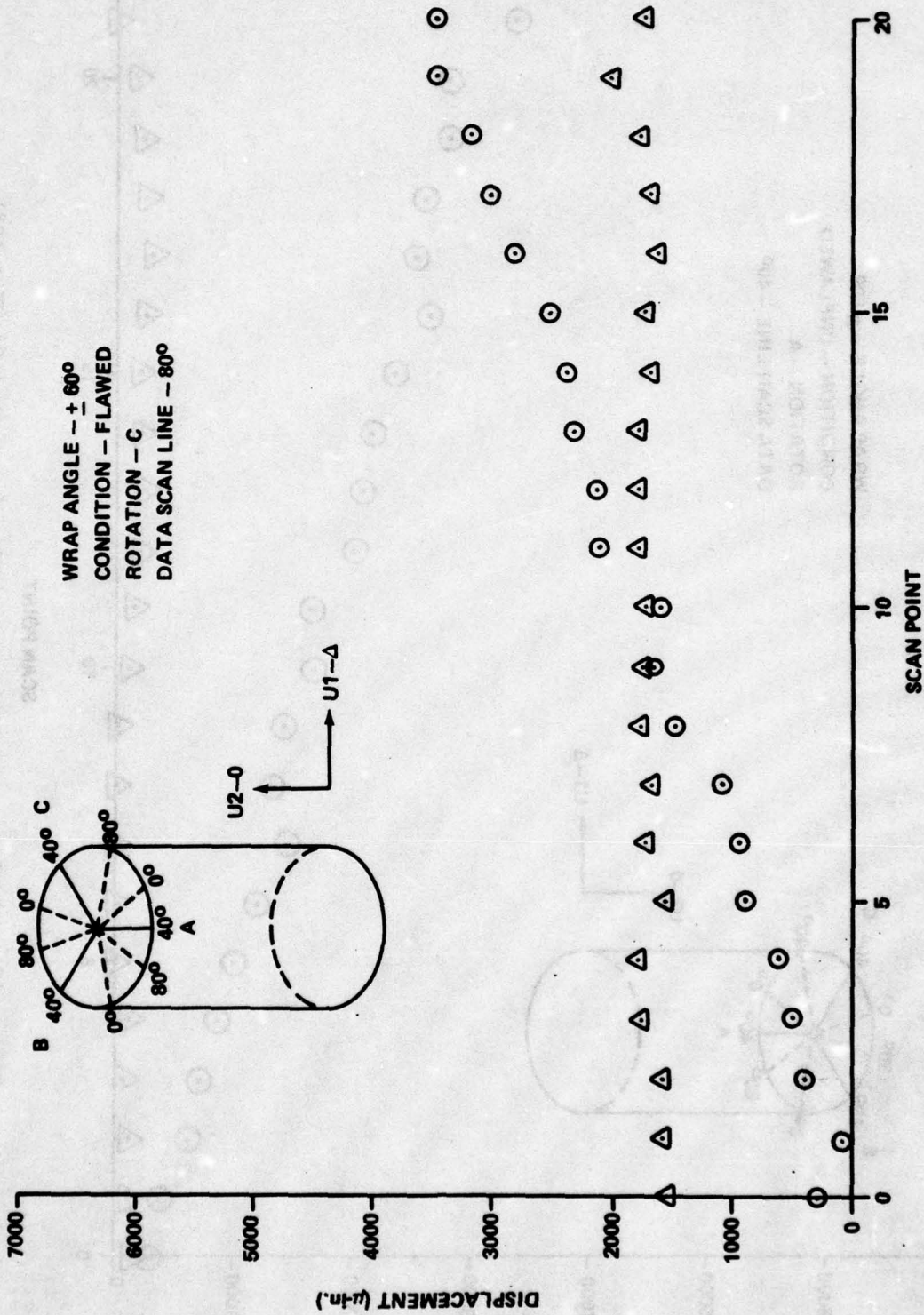

Figure 17. Displacement versus scan point for test (60°-F-C-80°).

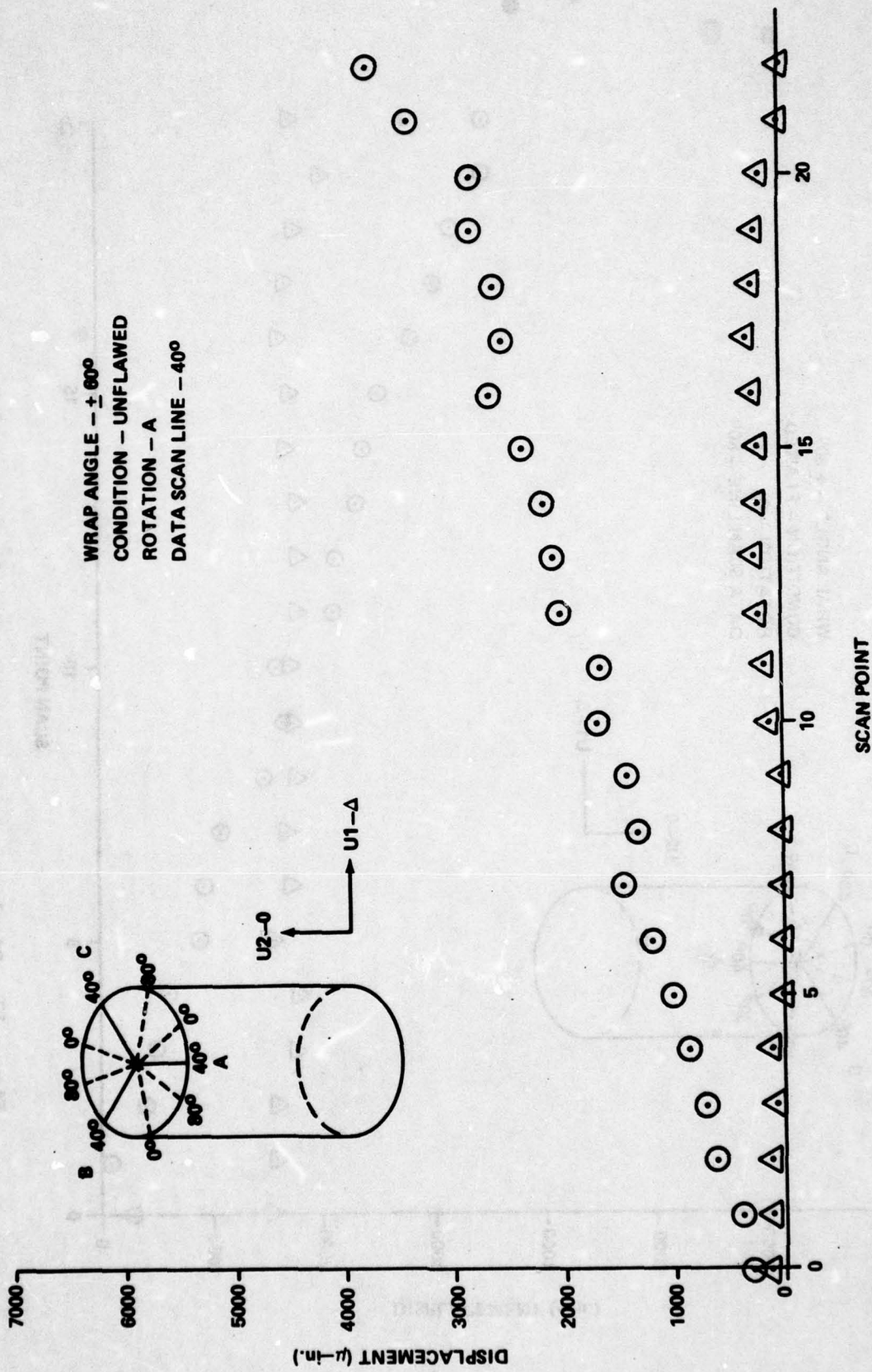

Figure 18. Displacement versus scan point for test (60° -WF-A- 40°).

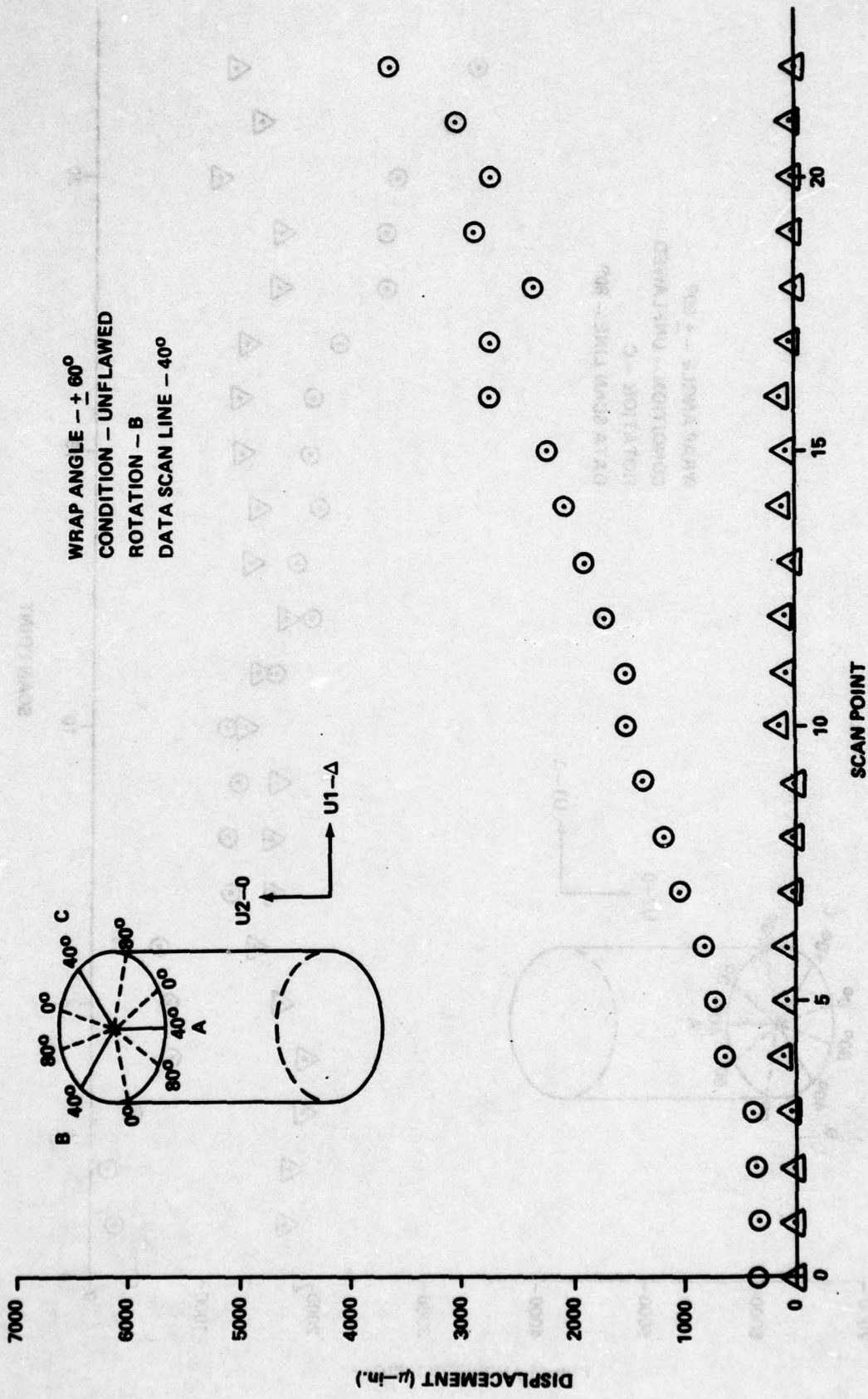

Figure 19. Displacement versus scan point for test (60° -WF-B- 40°).

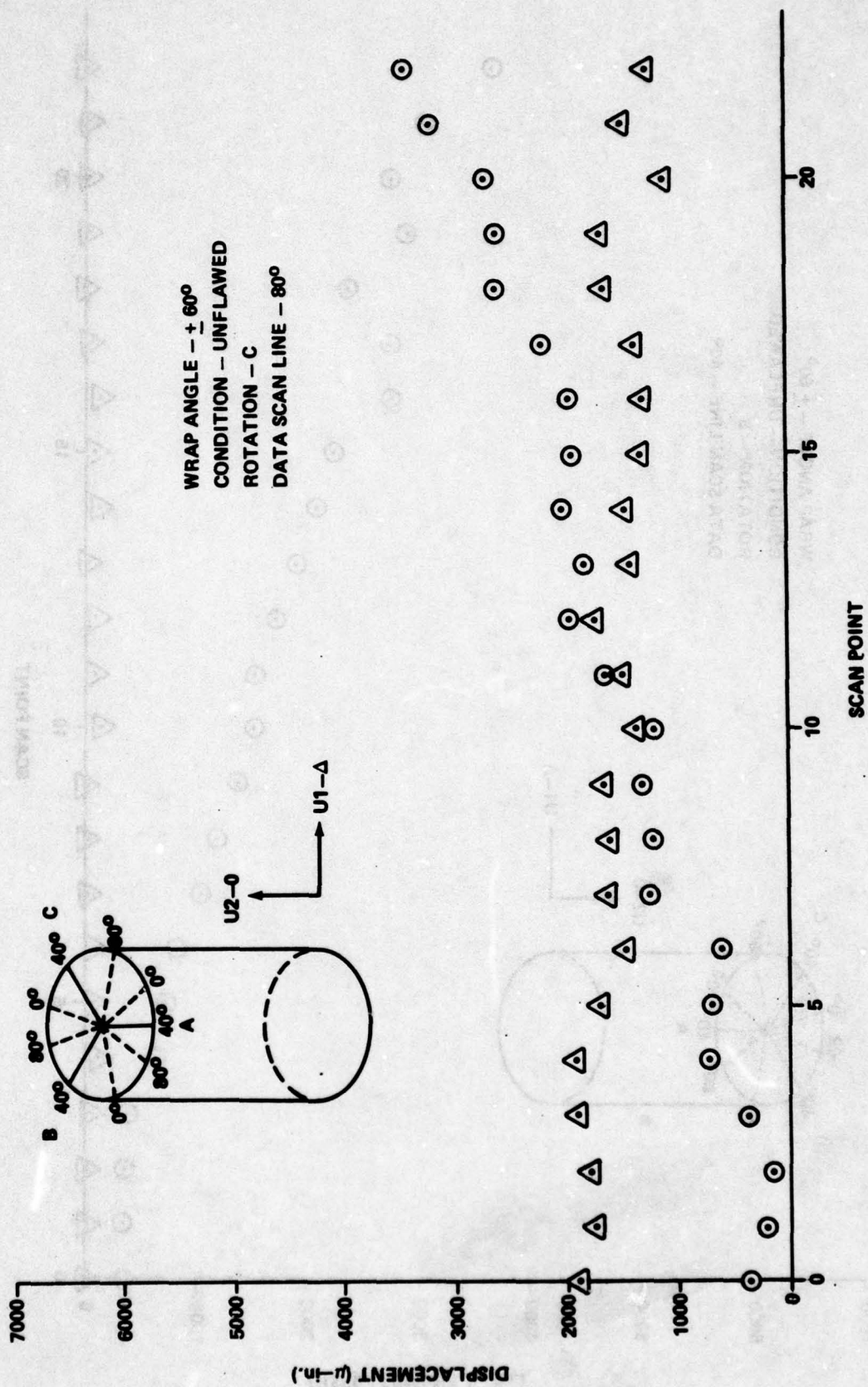

Figure 20. Displacement versus scan point for test (60°-WF-C-80°).

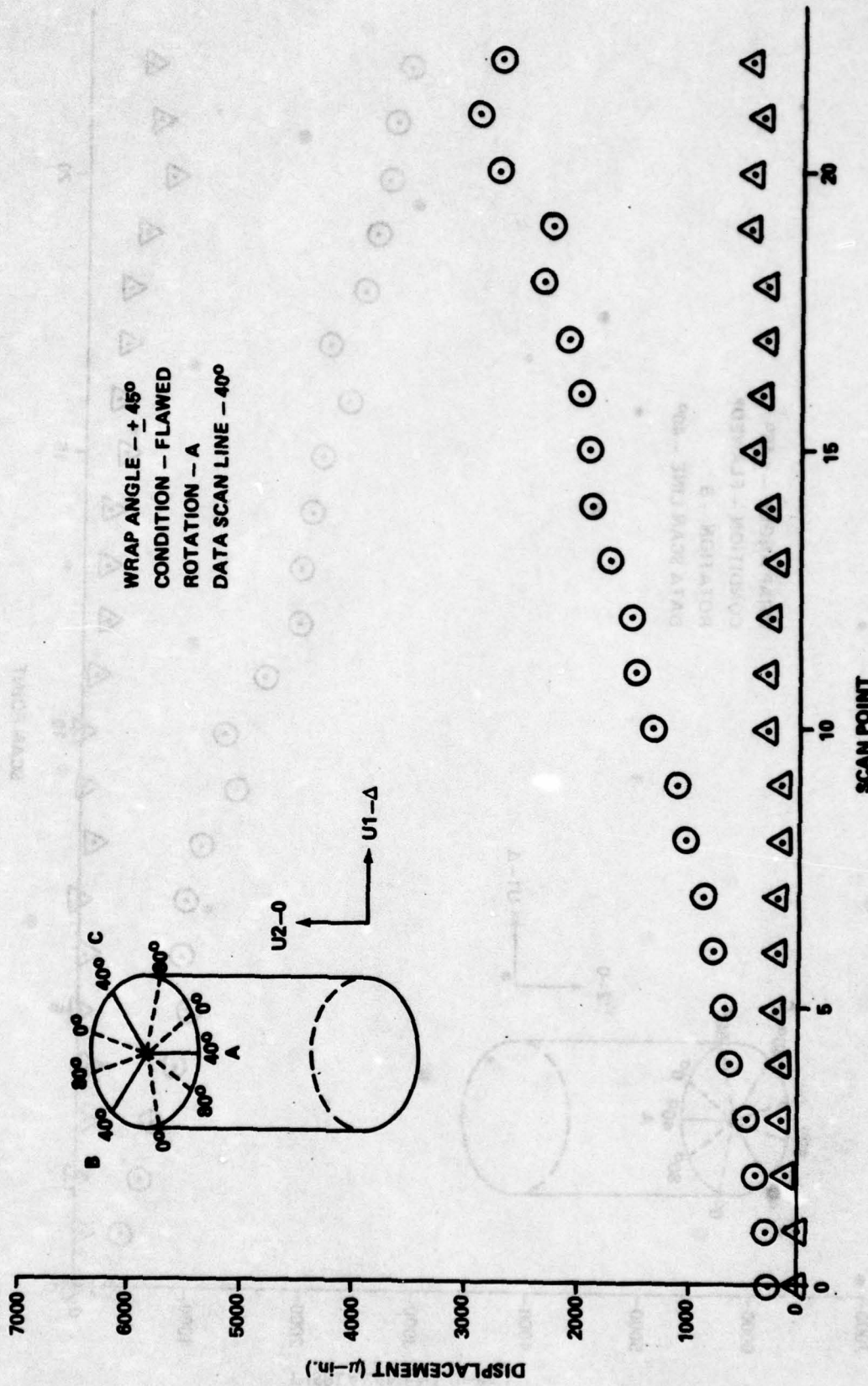

Figure 21. Displacement versus scan point for test (45° -F-A- 40°).

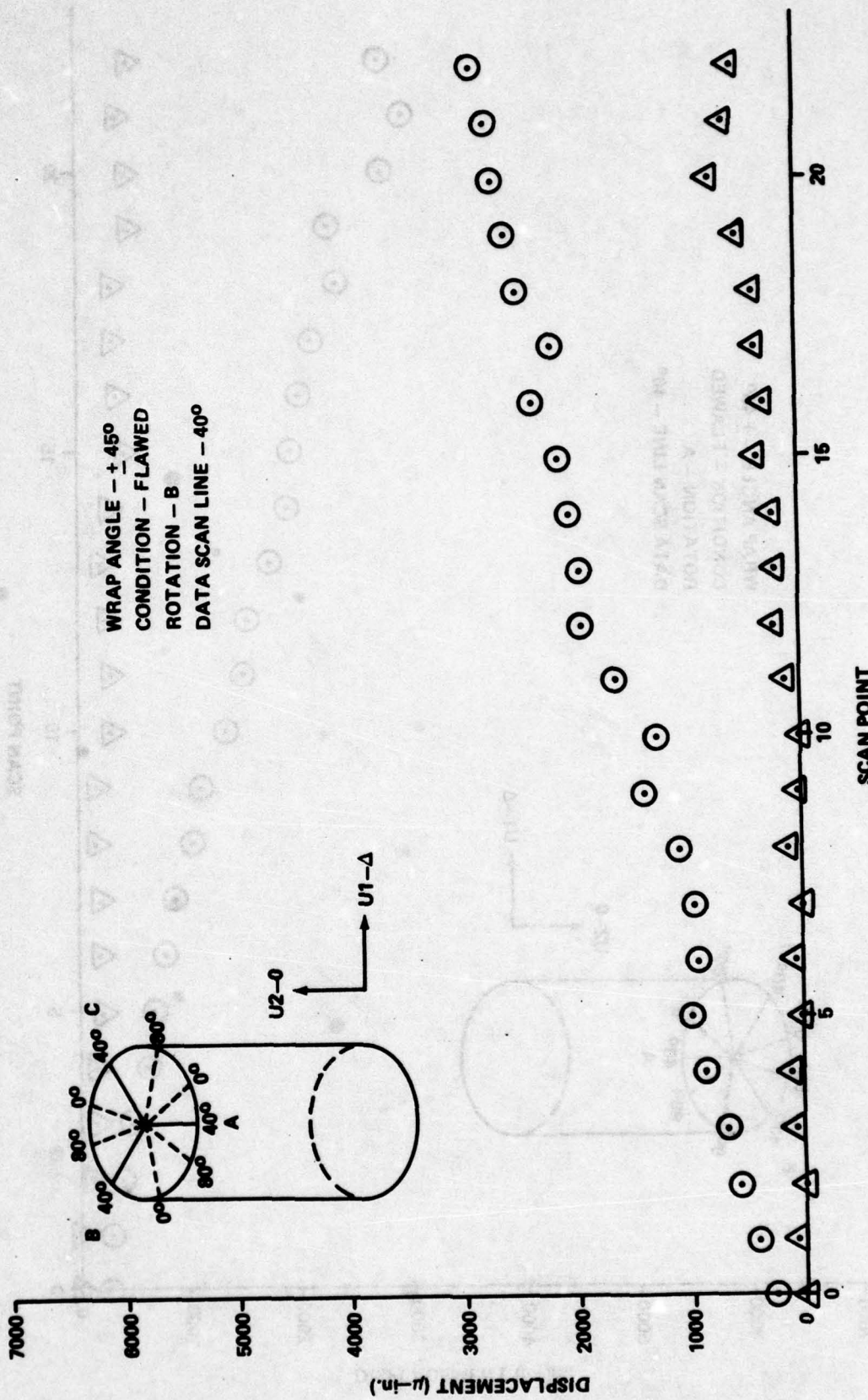

Figure 22. Displacement versus scan point for test (45°-F-B-40°).

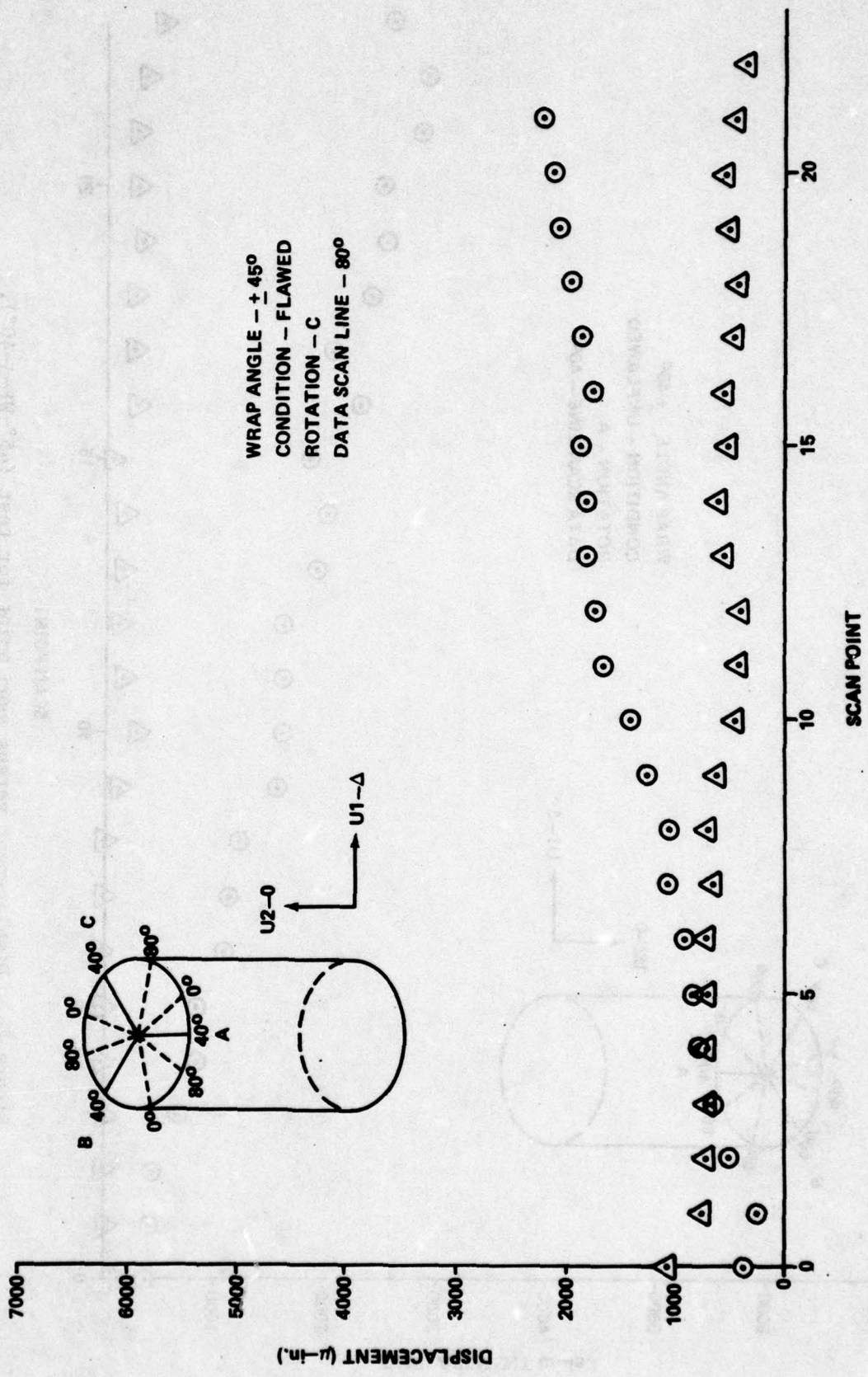

Figure 23. Displacement versus scan line for test (45°-F-C-80°).

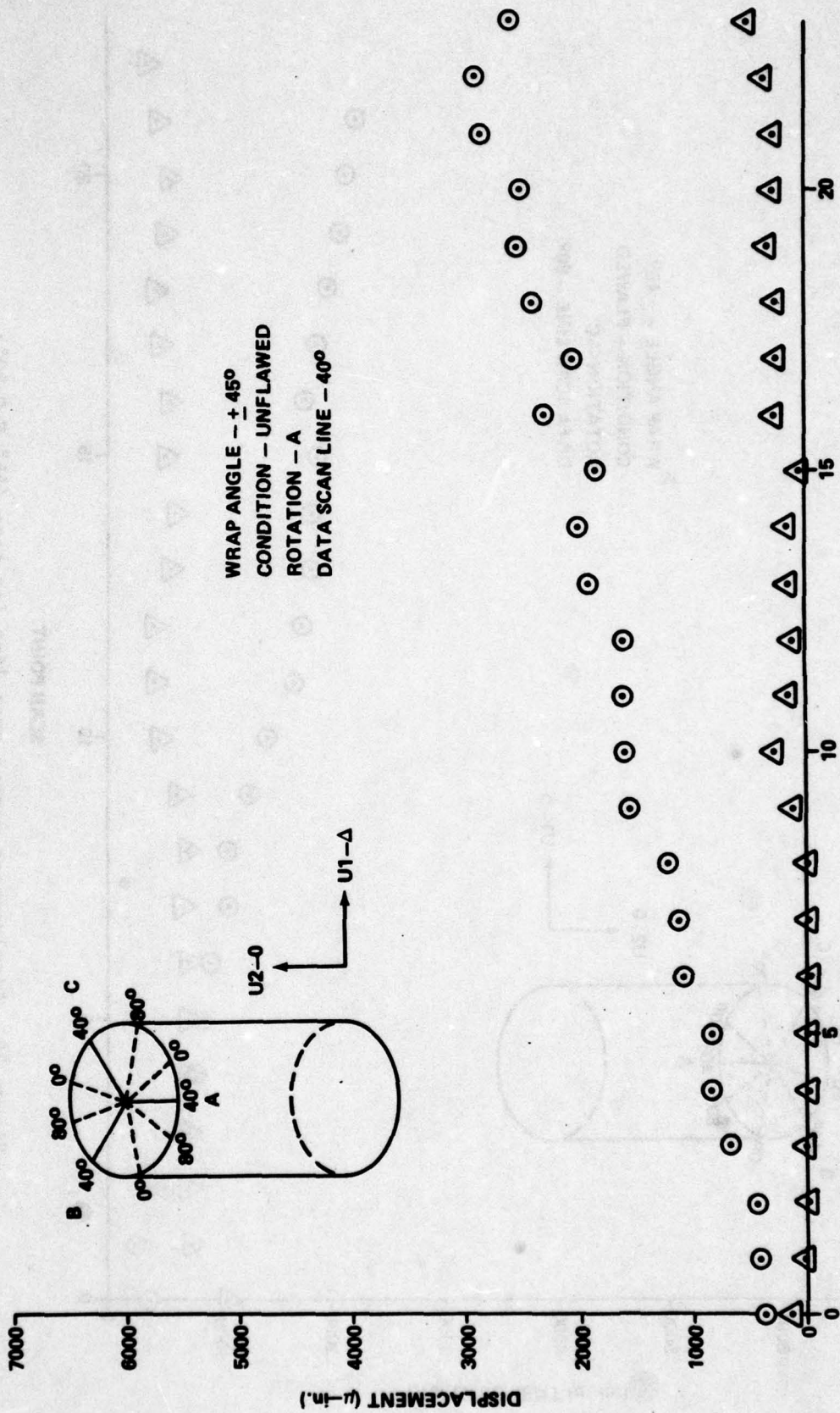

Figure 24. Displacement versus scan point for test (45°-WF-A-40°).

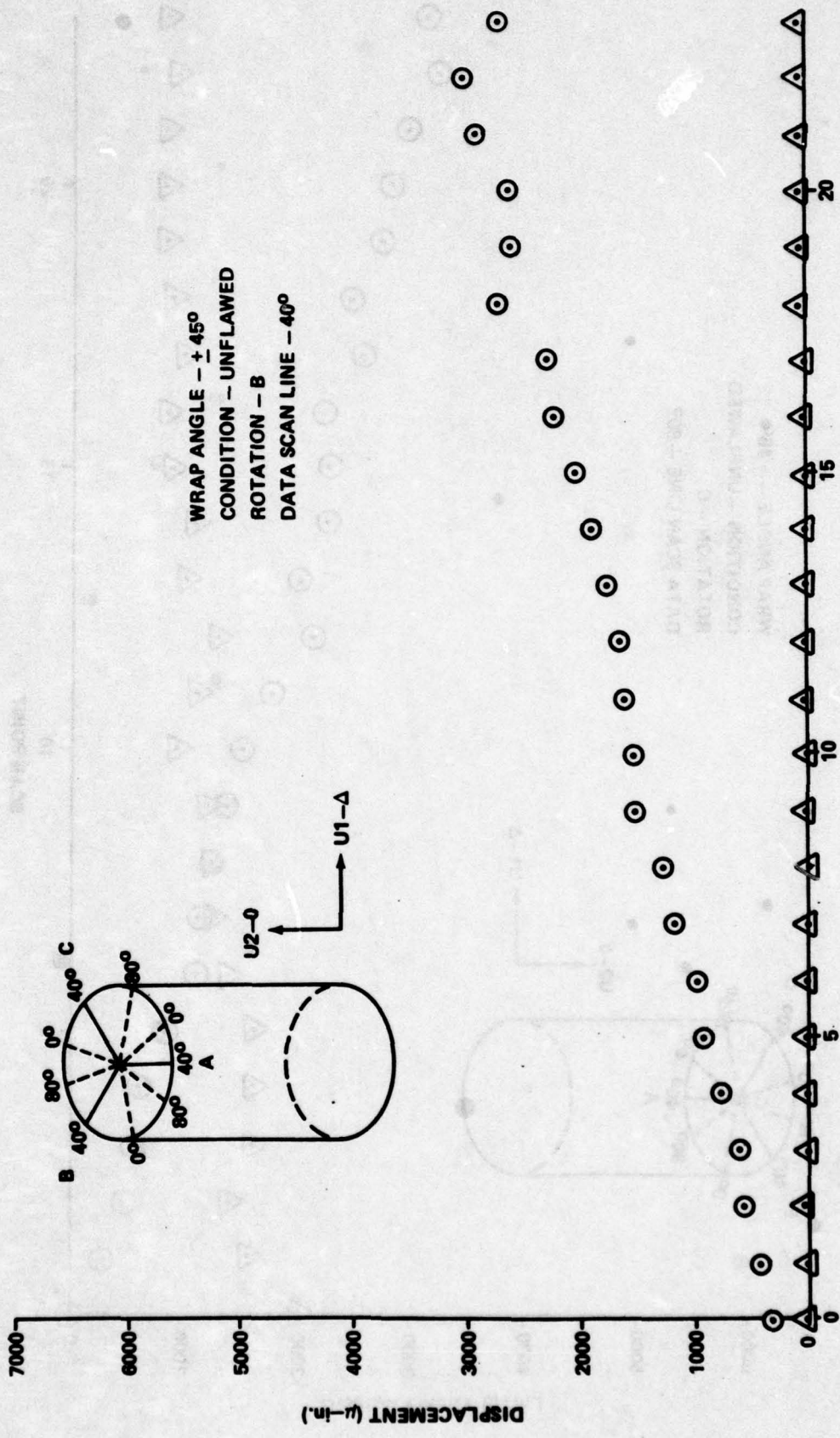

Figure 25. Displacement versus scan point for test (45°-WF-B-40°).

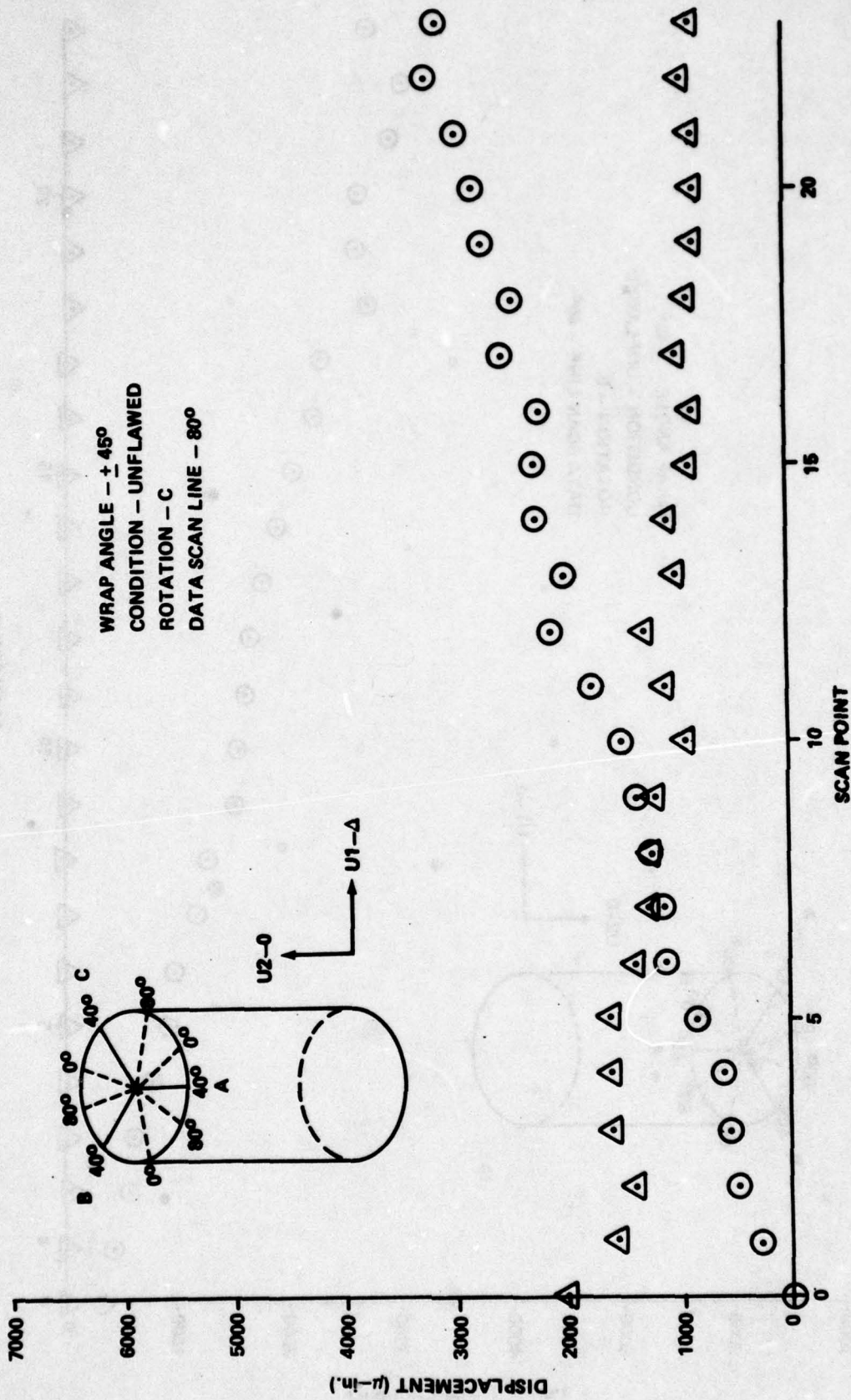
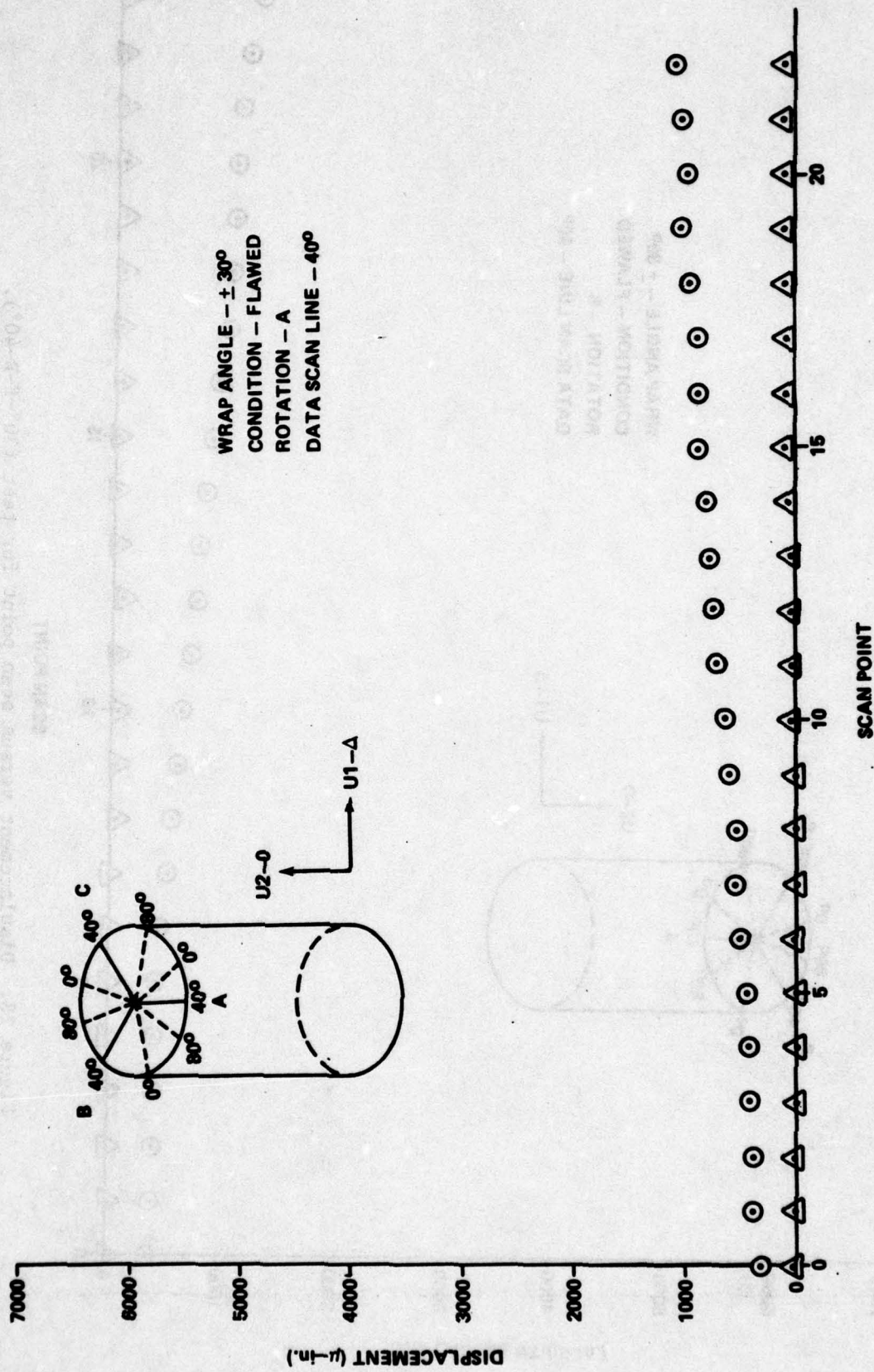

Figure 26. Displacement versus scan point for test (45°-WF-C-80°).



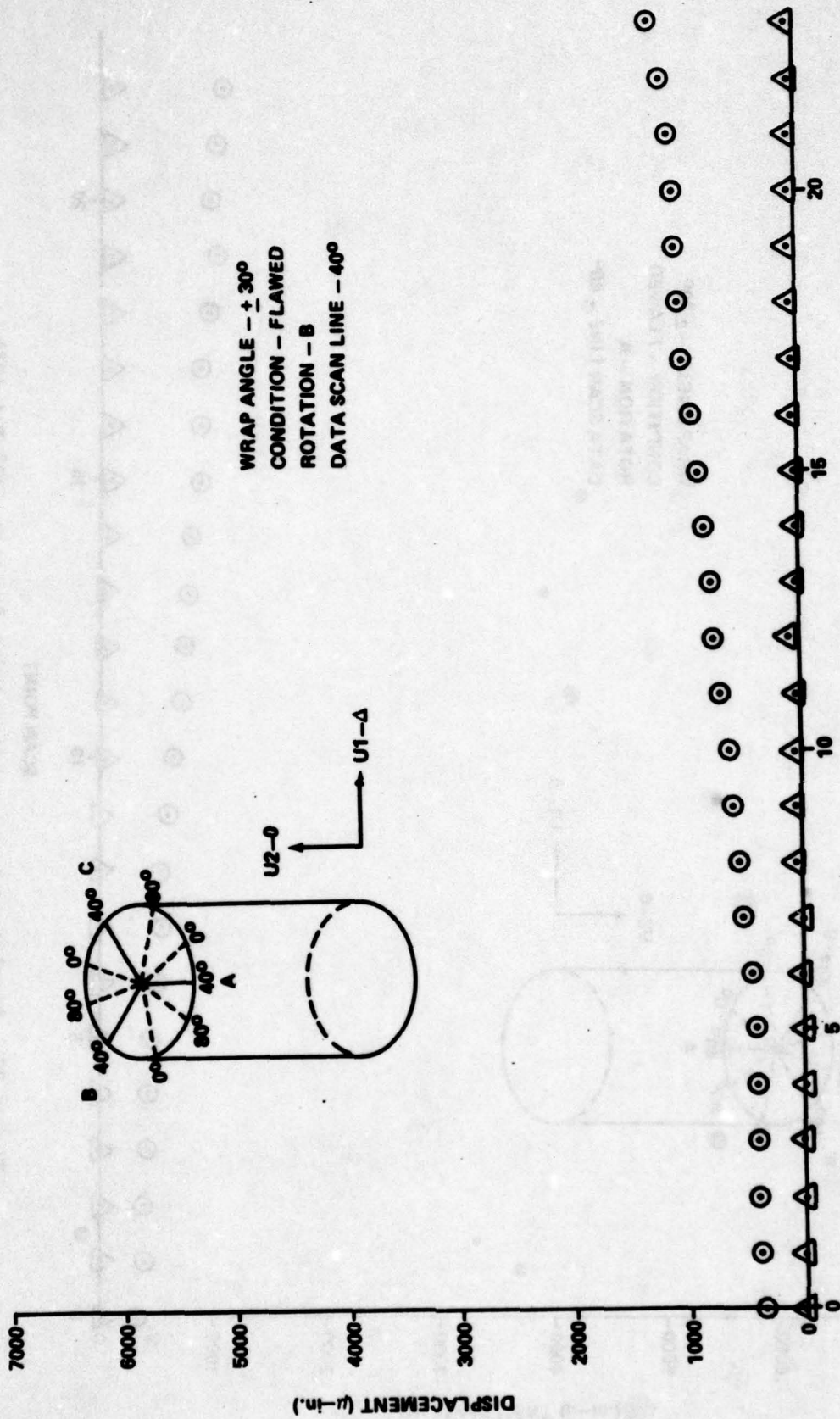

Figure 28. Displacement versus scan point for test (30°-F-B-40°).

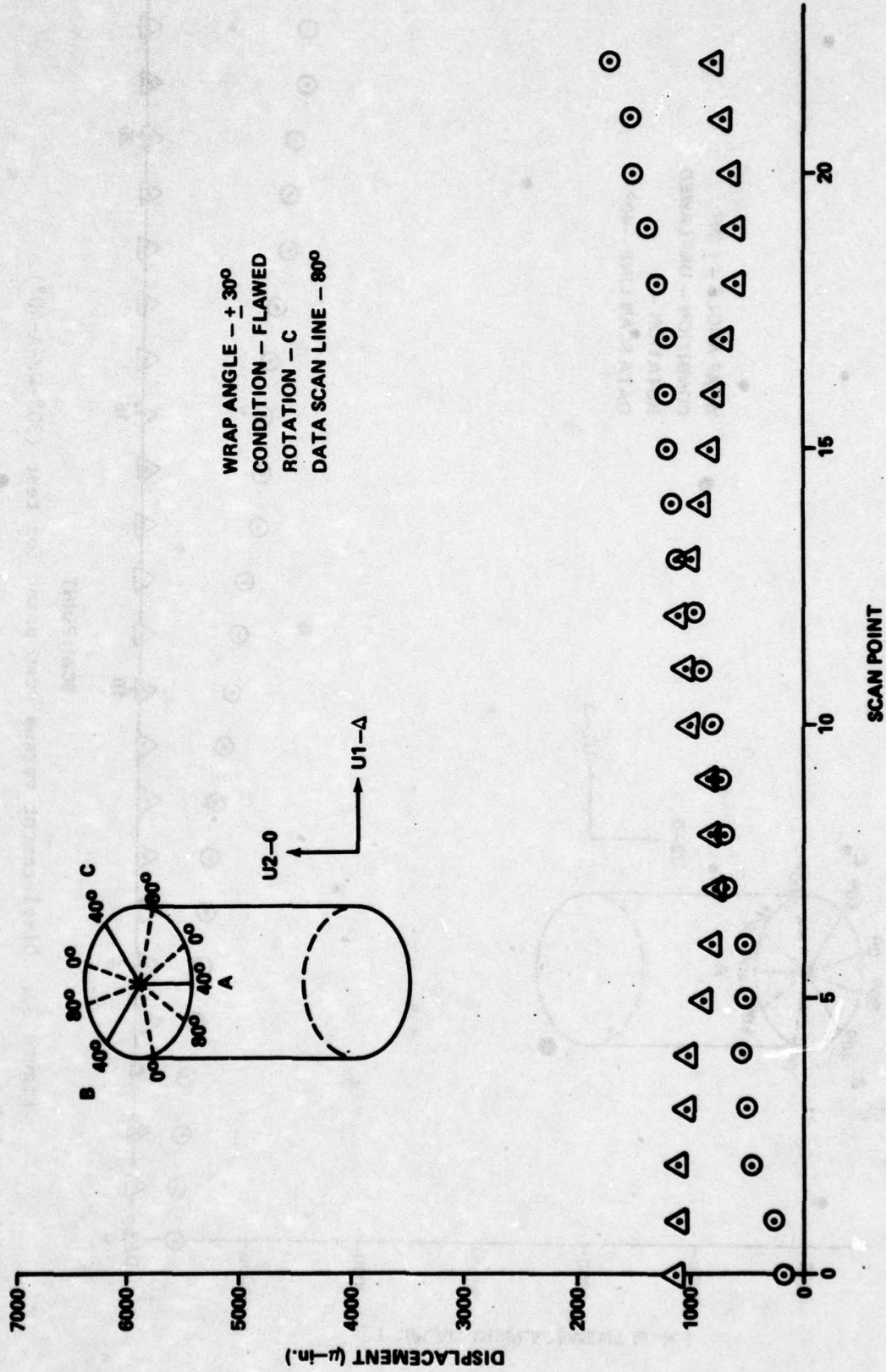

Figure 25. Displacement versus scan point for test (30°-F-C-30°).

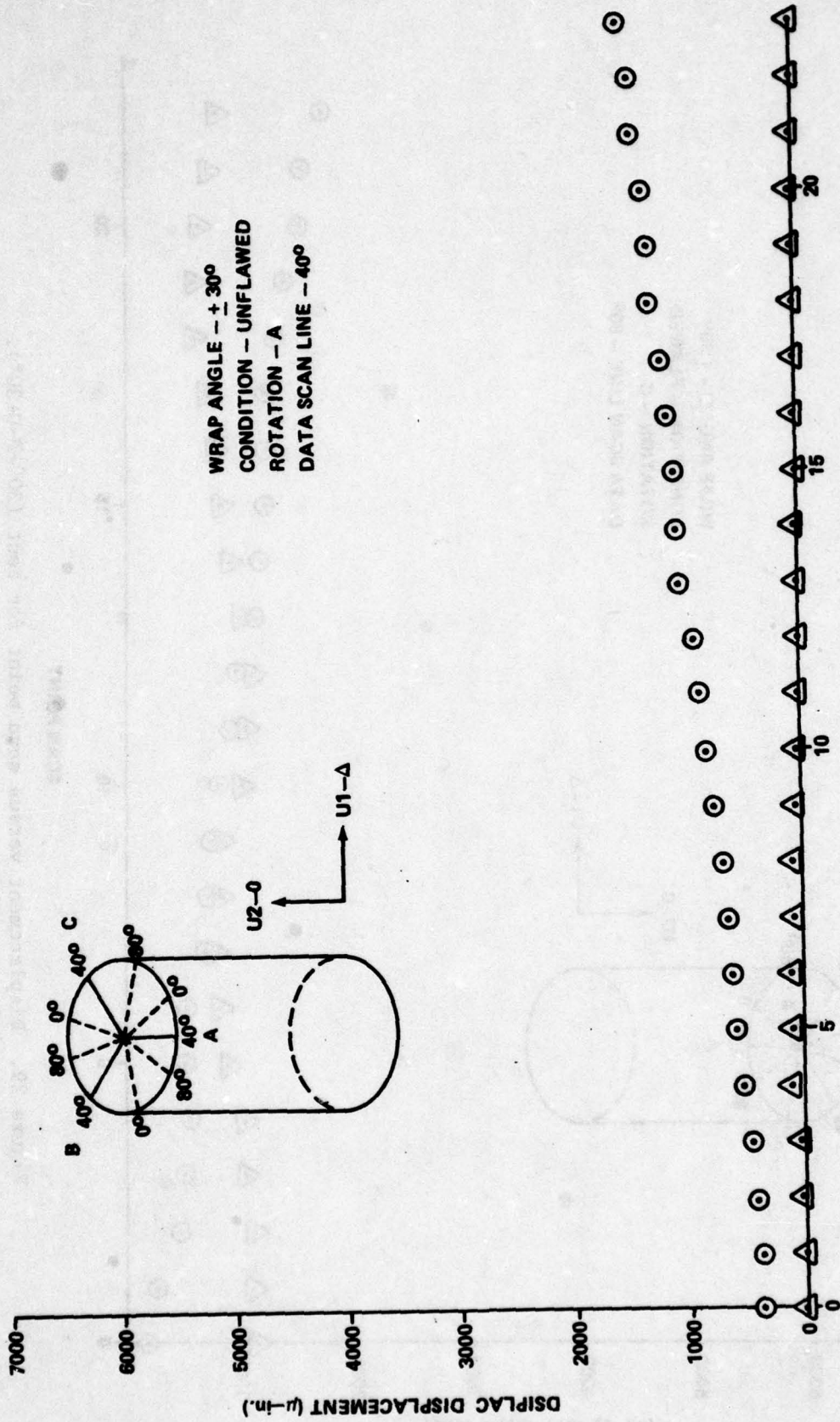

Figure 30. Displacement versus scan point for test (30°-WF-A-40°).

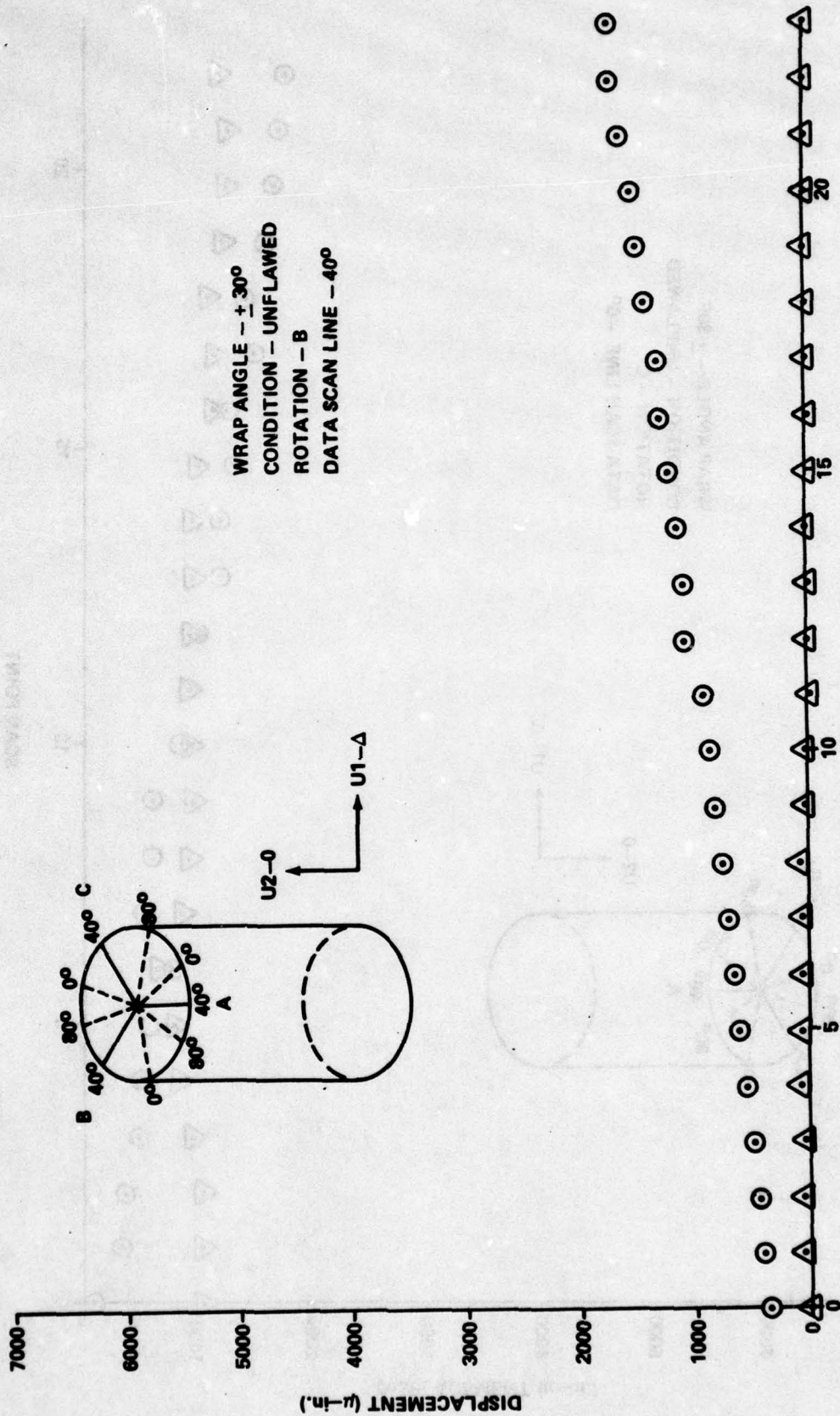

Figure 31. Displacement versus scan point for test (30°-WF-B-40°).

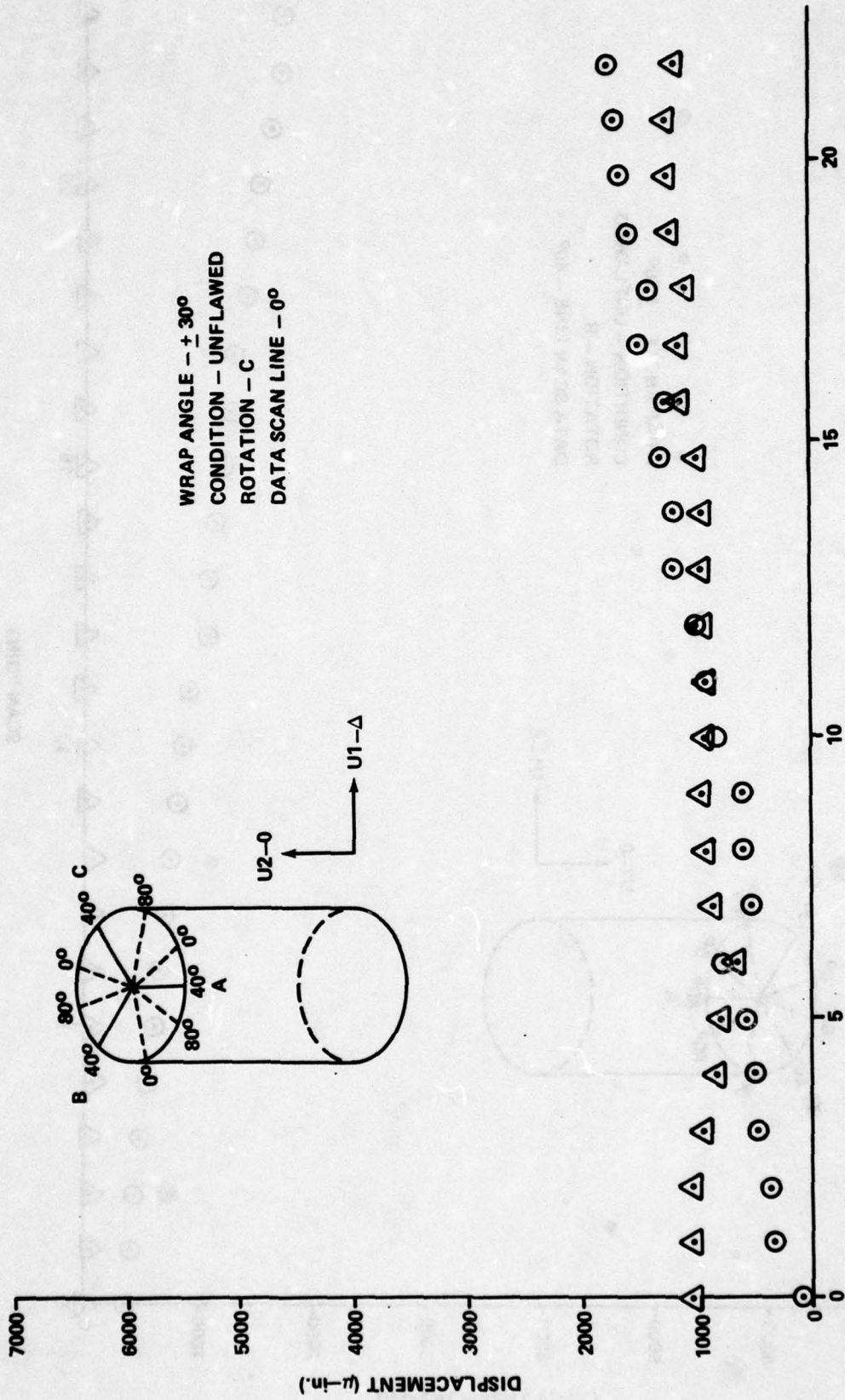

Figure 32. Displacement versus scan point for test (30°-WF-C-0°).

REFERENCES

1. Leendertz, J., "Interferometric Displacement Measurement on Scattering Surfaces Utilizing Speckle Effect," Journal of Physics E, Vol. 3, 1970, p. 214.
2. Shaw, W. A. and Smith, F. S., Strength of Materials, Limited Distribution, 1968.
3. Schaeffel, J. A., Mullinix, B. R., Ranson, W. F., and Swinson, W. F., Computer Aided Nondestructive Flaw Detection System for Composite Materials, US Army Missile Command, Redstone Arsenal, Alabama, Technical Report No. T-78-5, 26 September 1977.
4. Mullinix, B. R., Ranson, W. F., Swinson, W. F., and Cost, T. L., Quantification of Flaws in Fibered Composite Structures Using Interferometric Fringe Patterns, US Army Missile Command, Redstone Arsenal, Alabama, Technical Report RL-76-18, 20 April 1976.

PRECEDING PAGE BLANK-NOT FILMED

Appendix A. INPUT DATA USED TO CALCULATE ELASTICITY CONSTANTS

Test Cylinder No. 1, Flawed, +60° Wrap Angle, Position A
Displacements: U1 at 0°, U1 at 80°, U2 at 40° (in.)

DATA NO.	U10(I)	U180(I)	U2(I)
1	0.000314	0.001277	0.000275
2	0.002006	0.001475	0.000344
3	0.001414	0.001415	0.000544
4	0.001610	0.001406	0.000756
5	0.001367	0.001510	0.000920
6	0.001376	0.001651	0.001105
7	0.001296	0.001481	0.001259
8	0.001224	0.001582	0.001438
9	0.001400	0.001447	0.001559
10	0.001390	0.001532	0.001844
11	0.001273	0.001531	0.001928
12	0.001288	0.001562	0.001955
13	0.001288	0.001635	0.002147
14	0.001217	0.001432	0.002420
15	0.001178	0.001390	0.002424
16	0.001414	0.001371	0.002640
17	0.001234	0.001490	0.002828
18	0.001067	0.001560	0.002913
19	0.001537	0.001411	0.003220
20	0.001947	0.001532	0.003069
21	0.001829	0.001472	0.003240

Test Cylinder No. 1, Flawed, +60° Wrap Angle, Position B
Displacements: U1 at 0°, U1 at 80°, U2 at 40° (in.)

DATA NO.	U10(I)	U180(I)	U2(I)
1	0.002439	0.001321	0.000000
2	0.002192	0.001100	0.000000
3	0.002182	0.001067	0.000693
4	0.001862	0.001264	0.000665
5	0.002267	0.001241	0.000805
6	0.002036	0.001124	0.001062
7	0.001981	0.001240	0.001165
8	0.002130	0.001215	0.001312
9	0.001993	0.001125	0.001489
10	0.002191	0.001166	0.001665
11	0.002099	0.001089	0.001853
12	0.002225	0.001102	0.002009
13	0.001932	0.001105	0.002112
14	0.002017	0.001028	0.002238
15	0.002655	0.000888	0.002420
16	0.002017	0.000974	0.002525
17	0.002247	0.000833	0.002710
18	0.002343	0.001188	0.002838
19	0.002177	0.000785	0.002978
20	0.002177	0.000883	0.003312
21	0.002177	0.000896	0.003422

Test Cylinder No. 1, Flawed, +60° Wrap Angle, Position C
Displacements: U1 at 0°, U1 at 80°, U2 at 40° (in.)

DATA NO.	U10(I)	U180(I)	U2(I)
1	0.002189	0.001534	0.000363
2	0.002246	0.001555	0.000363
3	0.002246	0.001552	0.000363
4	0.002038	0.001727	0.000543
5	0.001936	0.001792	0.000674
6	0.001854	0.001548	0.000887
7	0.001792	0.001703	0.000955
8	0.001840	0.001660	0.001282
9	0.001689	0.001754	0.001509
10	0.001632	0.001715	0.001616
11	0.001623	0.001708	0.001775
12	0.001737	0.001788	0.001923
13	0.001562	0.001788	0.002103
14	0.001492	0.001757	0.002273
15	0.001451	0.001675	0.002570
16	0.001416	0.001719	0.002747
17	0.001820	0.001622	0.002833
18	0.001671	0.001665	0.002966
19	0.001592	0.001770	0.003139
20	0.001188	0.002014	0.003614
21	0.001426	0.001707	0.003605

Test Cylinder No. 2, Flawed, +60° Wrap Angle, Position A
Displacements: U1 at 0°, U1 at 80°, U2 at 40° (in.)

DATA NO.	U10(I)	U180(I)	U2(I)
1	0.000970	0.000913	0.000326
2	0.000980	0.001024	0.000575
3	0.000945	0.001065	0.000590
4	0.001053	0.000516	0.000595
5	0.001065	0.001195	0.000806
6	0.001181	0.001068	0.000933
7	0.000933	0.001068	0.001041
8	0.000938	0.001294	0.001374
9	0.000915	0.001309	0.001155
10	0.000896	0.001240	0.001371
11	0.000982	0.001218	0.001883
12	0.000997	0.001223	0.001796
13	0.000931	0.001263	0.001947
14	0.000951	0.001474	0.002382
15	0.000792	0.001424	0.002333
16	0.000605	0.001422	0.002245
17	0.000767	0.001326	0.002648
18	0.000657	0.001320	0.002913
19	0.000607	0.001426	0.003066
20	0.000428	0.001440	0.003242
21	0.000520	0.001584	0.003505

Test Cylinder No. 2, Flawed, +60° Wrap Angle, Position B
Displacements: U1 at 0°, U1 at 80°, U2 at 40° (in.)

DATA NO.	U10(I)	U180(I)	U2(I)
1	0.001152	0.000963	0.000326
2	0.001269	0.000964	0.000469
3	0.001112	0.001009	0.000751
4	0.001270	0.001121	0.001085
5	0.001244	0.001055	0.000827
6	0.000943	0.001043	0.001142
7	0.000942	0.001104	0.001298
8	0.000963	0.001290	0.001428
9	0.000847	0.001361	0.001489
10	0.000998	0.001190	0.001760
11	0.000805	0.001367	0.001904
12	0.000761	0.001308	0.002273
13	0.000496	0.001414	0.002301
14	0.000671	0.001460	0.002256
15	0.000715	0.001490	0.002347
16	0.000657	0.001523	0.002710
17	0.000691	0.001714	0.002787
18	0.000785	0.001714	0.003044
19	0.000602	0.001884	0.003109
20	0.000654	0.001828	0.003296
21	0.000542	0.001766	0.003595

Test Cylinder No. 2, Flawed, +60° Wrap Angle, Position C
Displacements: U1 at 0°, U1 at 80°, U2 at 40° (in.)

DATA NO.	U10(I)	U180(I)	U2(I)
1	0.000357	0.000745	0.000404
2	0.001180	0.000765	0.000530
3	0.001251	0.001009	0.000723
4	0.001176	0.000904	0.000867
5	0.001276	0.000879	0.000905
6	0.001276	0.000981	0.001062
7	0.001332	0.000947	0.001407
8	0.001321	0.000885	0.001598
9	0.001152	0.000929	0.001713
10	0.001067	0.000914	0.001975
11	0.001116	0.001056	0.001946
12	0.000895	0.001037	0.002285
13	0.000930	0.001131	0.002336
14	0.001033	0.001218	0.002290
15	0.000930	0.001266	0.002335
16	0.000820	0.001395	0.002595
17	0.000820	0.001320	0.002556
18	0.000945	0.001485	0.003213
19	0.000821	0.001472	0.003416
20	0.000743	0.001707	0.003731
21	0.000699	0.001645	0.003834

Test Cylinder No. 3, Flawed, +60° Wrap Angle, Position A
Displacements: U1 at 0°, U1 at 80°, U2 at 40° (in.)

DATA NO.	U10(I)	U180(I)	U2(I)
1	0.000325	0.000995	0.000751
2	0.001883	0.001039	0.000579
3	0.001610	0.000963	0.000285
4	0.001973	0.001221	0.000278
5	0.001951	0.000997	0.000278
6	0.001885	0.001064	0.000278
7	0.002020	0.000971	0.000360
8	0.001993	0.001004	0.000511
9	0.001702	0.001120	0.000528
10	0.001671	0.001137	0.000634
11	0.001892	0.000987	0.000788
12	0.001960	0.001005	0.000922
13	0.001990	0.001129	0.001072
14	0.002084	0.001183	0.001165
15	0.002035	0.000826	0.001440
16	0.002280	0.000799	0.001538
17	0.002218	0.001067	0.001750
18	0.002452	0.000859	0.001879
19	0.002571	0.000823	0.001978
20	0.002333	0.000860	0.002096
21	0.002450	0.000926	0.002253
22	0.002355	0.000719	0.002566

Test Cylinder NO. 3, Flawed, +60° Wrap Angle, Position B
Displacements: U1 at 0°, U1 at 80°, U2 at 40° (in.)

DATA NO.	U10(I)	U180(I)	U2(I)
1	0.000390	0.001364	0.000000
2	0.002020	0.001459	0.000306
3	0.001271	0.001351	0.000408
4	0.001536	0.001364	0.000584
5	0.001700	0.001066	0.000665
6	0.001820	0.001042	0.000816
7	0.001759	0.001075	0.001046
8	0.001865	0.000983	0.001161
9	0.001961	0.000936	0.001318
10	0.002446	0.001000	0.001410
11	0.002030	0.000742	0.001656
12	0.002249	0.000716	0.001729
13	0.002022	0.000649	0.001889
14	0.002196	0.000631	0.001942
15	0.002409	0.000607	0.002149
16	0.002401	0.000552	0.002383
17	0.002374	0.000488	0.002928
18	0.002165	0.000926	0.002858
19	0.002530	0.000642	0.002603
20	0.002987	0.000539	0.002914
21	0.003072	0.000279	0.003172
22	0.002770	0.000472	0.004039

Test Cylinder No. 3, Flawed, +60° Wrap Angle, Position C
Displacements: U1 at 0°, U1 at 80°, U2 at 40° (in.)

DATA NO.	U10(I)	U180(I)	U2(I)
1	0.000449	0.000469	0.000406
2	0.001128	0.001682	0.000531
3	0.001072	0.001944	0.000694
4	0.001089	0.001709	0.000825
5	0.001023	0.001743	0.001003
6	0.000981	0.001947	0.001146
7	0.001131	0.001556	0.001387
8	0.000946	0.001849	0.001486
9	0.000932	0.002134	0.001625
10	0.000892	0.001963	0.001710
11	0.000971	0.002078	0.001867
12	0.000826	0.001963	0.002225
13	0.000954	0.001910	0.002324
14	0.001063	0.001996	0.002273
15	0.000860	0.001996	0.002382
16	0.000955	0.002299	0.002681
17	0.000926	0.001954	0.002758
18	0.000781	0.001737	0.002917
19	0.000965	0.002014	0.003083
20	0.000882	0.002014	0.003268
21	0.000766	0.001956	0.003743
22	0.000665	0.002501	0.003494

Test Cylinder No. 4, Flawed, +60° Wrap Angle, Position A
Displacements: U1 at 0°, U1 at 80°, U2 at 40° (in.)

DATA NO.	U10(I)	U180(I)	U2(I)
1	0.001676	0.001737	0.000408
2	0.001571	0.001956	0.000452
3	0.001585	0.002304	0.000584
4	0.001595	0.001759	0.000660
5	0.001595	0.001748	0.000838
6	0.001524	0.001829	0.000987
7	0.001520	0.001866	0.001371
8	0.001485	0.001652	0.001408
9	0.001524	0.001654	0.001446
10	0.001386	0.001721	0.001600
11	0.001443	0.001688	0.001821
12	0.001236	0.001594	0.001953
13	0.001477	0.001625	0.002155
14	0.001435	0.001586	0.002031
15	0.001514	0.001737	0.002400
16	0.001463	0.001826	0.002400
17	0.001498	0.001599	0.002777
18	0.001251	0.001502	0.002640
19	0.001498	0.001600	0.002777
20	0.001543	0.001707	0.003299
21	0.001481	0.001780	0.003909
22	0.001386	0.001844	0.003298
23	0.001587	0.001370	0.003515

Test Cylinder No. 4, Flawed, +60° Wrap Angle, Position B
Displacements: U1 at 0°, U1 at 80°, U2 at 40° (in.)

DATA NO.	U10(I)	U180(I)	U2(I)
1	0.000424	0.001891	0.000422
2	0.001525	0.001862	0.000391
3	0.001386	0.001687	0.000378
4	0.001195	0.001609	0.000368
5	0.001255	0.001600	0.000402
6	0.001260	0.001404	0.000663
7	0.001117	0.001413	0.000770
8	0.000960	0.001509	0.000963
9	0.000933	0.001371	0.001165
10	0.001019	0.001265	0.001463
11	0.000921	0.001411	0.001445
12	0.000926	0.001303	0.001596
13	0.000989	0.001321	0.001881
14	0.001067	0.001278	0.001917
15	0.000992	0.001278	0.002290
16	0.001014	0.001347	0.002508
17	0.000860	0.001332	0.002442
18	0.000901	0.001502	0.002620
19	0.000850	0.001286	0.002772
20	0.000905	0.001227	0.002833
21	0.000970	0.001319	0.003001
22	0.000672	0.001591	0.003282
23	0.000646	0.001474	0.003282

Test Cylinder No. 4, Flawed, +60° Wrap Angle, Position C
 Displacements: U1 at 0°, U1 at 80°, U2 at 40° (in.)

DATA NO.	U10(I)	U180(I)	U2(I)
1	0.000315	0.001392	0.000381
2	0.001753	0.001476	0.000391
3	0.001885	0.001089	0.000391
4	0.002245	0.001422	0.000391
5	0.001394	0.001351	0.000414
6	0.001557	0.001275	0.000488
7	0.001195	0.001240	0.000710
8	0.001519	0.001218	0.001085
9	0.001302	0.001140	0.000915
10	0.001207	0.001207	0.001103
11	0.001266	0.001334	0.001572
12	0.001055	0.001385	0.001567
13	0.001257	0.001250	0.001667
14	0.001241	0.001188	0.001727
15	0.001181	0.001312	0.001985
16	0.001200	0.001332	0.001842
17	0.001162	0.001239	0.002235
18	0.001090	0.001347	0.002382
19	0.001262	0.001599	0.002442
20	0.001218	0.001651	0.002826
21	0.000976	0.001362	0.003083
22	0.000719	0.001493	0.003083
23	0.001051	0.001493	0.003275

Test Cylinder No. 5, Unflawed, +60° Wrap Angle, Position A
 Displacements: U1 at 0°, U1 at 80°, U2 at 40° (in.)

DATA NO.	U10(I)	U180(I)	U2(I)
1	0.001395	0.000362	0.001088
2	0.001345	0.001218	0.001077
3	0.001261	0.001440	0.000951
4	0.001199	0.001060	0.000891
5	0.001565	0.001110	0.000589
6	0.001438	0.000981	0.000418
7	0.001401	0.000894	0.000150
8	0.001461	0.000958	0.000111
9	0.001486	0.000917	0.000073
10	0.001891	0.000794	0.000062
11	0.001699	0.000779	0.000316
12	0.001545	0.000746	0.000453
13	0.001406	0.000627	0.000608
14	0.001493	0.000503	0.000659
15	0.001518	0.000586	0.000838
16	0.001460	0.000507	0.000927
17	0.001737	0.000485	0.001091
18	0.001578	0.000477	0.001188
19	0.001771	0.000553	0.001351
20	0.001966	0.000529	0.001384
21	0.001899	0.000411	0.001813
22	0.001688	0.000464	0.001813
23	0.002018	0.000342	0.001913
24	0.002053	0.000448	0.002113

Test Cylinder No. 5, Unflawed, +60° Wrap Angle, Position B
Displacements: U1 at 0°, U1 at 80°, U2 at 40° (in.)

DATA NO.	U10(I)	U180(I)	U2(I)
1	0.000358	0.001481	0.000357
2	0.001426	0.001341	0.000357
3	0.001594	0.001242	0.000357
4	0.001527	0.001281	0.000357
5	0.001529	0.001139	0.000388
6	0.001464	0.001264	0.000468
7	0.001568	0.001249	0.000652
8	0.001651	0.001265	0.000838
9	0.001287	0.001109	0.000987
10	0.001364	0.001172	0.001088
11	0.001310	0.001150	0.001214
12	0.001129	0.001178	0.001576
13	0.001104	0.001063	0.001576
14	0.000903	0.001119	0.001644
15	0.001359	0.001123	0.001785
16	0.001342	0.000985	0.001953
17	0.001478	0.001251	0.002324
18	0.001826	0.000920	0.002020
19	0.001737	0.001179	0.002501
20	0.001773	0.000536	0.002139
21	0.001514	0.000728	0.002334
22	0.001754	0.000759	0.002752
23	0.001600	0.000774	0.002496
24	0.001600	0.000593	0.003094

Test Cylinder No. 5, Unflawed, +60° Wrap Angle, Position C
 Displacements: U1 at 0°, U1 at 80°, U2 at 40° (in.)

DATA NO.	U10(I)	U180(I)	U2(I)
1	0.001252	0.000000	0.000371
2	0.001268	0.001812	0.000414
3	0.001255	0.001744	0.000420
4	0.001184	0.001654	0.000672
5	0.001148	0.001692	0.000593
6	0.001110	0.001565	0.000902
7	0.001300	0.001324	0.001135
8	0.001358	0.001309	0.001187
9	0.001187	0.001200	0.001403
10	0.001146	0.001234	0.001465
11	0.001135	0.001329	0.001674
12	0.001065	0.001123	0.001992
13	0.001174	0.000985	0.001982
14	0.001435	0.000960	0.002199
15	0.001078	0.000840	0.002199
16	0.001123	0.001147	0.002246
17	0.001347	0.000882	0.002400
18	0.001173	0.000936	0.002400
19	0.001506	0.000720	0.002854
20	0.001549	0.001020	0.002574
21	0.001447	0.001129	0.002777
22	0.001493	0.000792	0.003017
23	0.001599	0.000757	0.003519
24	0.001528	0.000784	0.003015

Test Cylinder No. 6, Unflawed, $\pm 60^\circ$ Wrap Angle, Position A
Displacements: U1 at 0° , U1 at 80° , U2 at 40° (in.)

DATA NO.	U10(I)	U180(I)	U2(I)
1	0.001023	0.001619	0.000327
2	0.001045	0.001758	0.000327
3	0.000944	0.001487	0.000347
4	0.001049	0.001660	0.000431
5	0.001054	0.001588	0.000589
6	0.001095	0.001325	0.000794
7	0.001092	0.001490	0.000980
8	0.000970	0.001539	0.000987
9	0.001121	0.001573	0.001207
10	0.001182	0.001407	0.001351
11	0.001136	0.001471	0.001596
12	0.001056	0.001583	0.001753
13	0.001142	0.001354	0.001839
14	0.001244	0.001211	0.002011
15	0.001153	0.001384	0.002100
16	0.001257	0.001288	0.002394
17	0.001271	0.001251	0.002701
18	0.001157	0.001600	0.002929
19	0.001323	0.001551	0.002929
20	0.001214	0.001432	0.003015
21	0.001302	0.001528	0.003299
22	0.001129	0.001591	0.003641
23	0.001423	0.001587	0.003641

Test Cylinder No. 6, Unflawed, +60° Wrap Angle, Position B
Displacements: U1 at 0°, U1 at 80°, U2 at 40° (in.)

DATA NO.	U10(I)	U180(I)	U2(I)
1	0.001664	0.001781	0.000363
2	0.001279	0.001824	0.000457
3	0.001314	0.001767	0.000567
4	0.001365	0.001931	0.000682
5	0.001347	0.001834	0.000879
6	0.001172	0.001920	0.001130
7	0.001075	0.001793	0.001146
8	0.001129	0.001794	0.001263
9	0.001178	0.001562	0.001564
10	0.001215	0.001697	0.001547
11	0.001414	0.001706	0.001818
12	0.000943	0.002247	0.001842
13	0.000948	0.001767	0.002016
14	0.001180	0.001776	0.002147
15	0.001191	0.001955	0.002244
16	0.001180	0.002121	0.002391
17	0.001129	0.001643	0.002777
18	0.001187	0.001968	0.002850
19	0.001251	0.001954	0.002852
20	0.001352	0.002130	0.002854
21	0.001364	0.001813	0.003104
22	0.001204	0.001765	0.003641
23	0.001113	0.001956	0.003771

Test Cylinder No. 6, Unflawed, +60° Wrap Angle, Position C
Displacements: U1 at 0°, U1 at 80°, U2 at 40° (in.)

DATA NO.	U10(I)	U180(I)	U2(I)
1	0.000735	0.001847	0.000440
2	0.000746	0.001896	0.000281
3	0.000657	0.002045	0.000260
4	0.000692	0.002154	0.000264
5	0.000700	0.001820	0.000276
6	0.000701	0.002086	0.000330
7	0.000640	0.002287	0.000325
8	0.000535	0.001980	0.000520
9	0.000514	0.002040	0.000644
10	0.000591	0.002260	0.000802
11	0.000533	0.002274	0.000936
12	0.000639	0.002060	0.001072
13	0.000403	0.002184	0.001314
14	0.000462	0.002110	0.001348
15	0.000535	0.002104	0.001507
16	0.000314	0.001962	0.001720
17	0.000377	0.002180	0.001889
18	0.000457	0.002736	0.001979
19	0.000406	0.002096	0.002025
20	0.000448	0.002620	0.002253
21	0.000470	0.002341	0.002277
22	0.000375	0.002215	0.002607
23	0.000446	0.002715	0.002745

Test Cylinder No. 7, Unflawed, +60 Wrap Angle, Position A
Displacements: U1 at 0°, U1 at 80°, U2 at 40° (in.)

DATA NO.	U10(I)	U180(I)	U2(I)
1	0.000391	0.000398	0.000325
2	0.001045	0.002025	0.000268
3	0.001103	0.002560	0.000360
4	0.000940	0.002600	0.000486
5	0.000862	0.002757	0.000730
6	0.000718	0.002869	0.000851
7	0.000754	0.003698	0.000999
8	0.000883	0.002543	0.001115
9	0.000900	0.002587	0.001196
10	0.000846	0.002771	0.001321
11	0.000955	0.002858	0.001417
12	0.000881	0.002952	0.001672
13	0.000811	0.002918	0.001821
14	0.000985	0.003089	0.001905
15	0.000992	0.002768	0.002066
16	0.000890	0.002889	0.002025
17	0.000880	0.002489	0.002245
18	0.000842	0.002713	0.002591
19	0.000735	0.002575	0.002667
20	0.000772	0.002828	0.002980
21	0.001032	0.002501	0.002681
22	0.000816	0.002617	0.002889
23	0.000901	0.002951	0.003161

Test Cylinder No. 7, Unflawed, +60° Wrap Angle, Position B
Displacements: U1 at 0°, U1 at 80°, U2 at 40° (in.)

DATA NO.	U10(I)	U180(I)	U2(I)
1	0.000413	0.000391	0.000405
2	0.001029	0.001697	0.000560
3	0.001233	0.002157	0.000697
4	0.001109	0.002081	0.000877
5	0.001124	0.002109	0.000942
6	0.001139	0.002045	0.001045
7	0.001226	0.002315	0.001173
8	0.001032	0.001796	0.001354
9	0.001113	0.002074	0.001320
10	0.001102	0.001776	0.001676
11	0.001414	0.001757	0.001731
12	0.001661	0.002018	0.001731
13	0.001297	0.001662	0.001886
14	0.001236	0.001835	0.002031
15	0.001440	0.002057	0.002247
16	0.001399	0.001939	0.002576
17	0.001438	0.001893	0.002854
18	0.001435	0.001646	0.002708
19	0.001473	0.001821	0.002854
20	0.001551	0.002140	0.002708
21	0.001651	0.002387	0.003300
22	0.001458	0.001828	0.003406
23	0.001600	0.002084	0.004224

Test Cylinder No. 7, Unflawed, +60° Wrap Angle, Position C
Displacements: U1 at 0°, U1 at 80°, U2 at 40° (in.)

DATA NO.	U10(I)	U180(I)	U2(I)
1	0.000371	0.000431	0.000390
2	0.000994	0.000431	0.000473
3	0.000975	0.002488	0.000495
4	0.000993	0.002429	0.000774
5	0.001108	0.002450	0.000884
6	0.001172	0.002817	0.000872
7	0.001023	0.002954	0.001119
8	0.001187	0.002472	0.001158
9	0.001212	0.002338	0.001370
10	0.001095	0.002279	0.001487
11	0.001182	0.002154	0.001553
12	0.001478	0.002378	0.001731
13	0.001271	0.002058	0.001955
14	0.001046	0.001872	0.001920
15	0.001078	0.001812	0.001820
16	0.001554	0.002050	0.002575
17	0.001354	0.002121	0.002246
18	0.001389	0.002215	0.002779
19	0.001463	0.001942	0.002514
20	0.001249	0.002089	0.002706
21	0.001422	0.002073	0.003094
22	0.001599	0.002176	0.002922
23	0.001493	0.001710	0.003393

Test Cylinder No. 8, Unflawed, +60° Wrap Angle, Position A
Displacements: U1 at 0°, U1 at 80°, U2 at 40° (in.)

DATA NO.	U10(I)	U180(I)	U2(I)
1	0.000422	0.002456	0.000289
2	0.001016	0.002456	0.000361
3	0.000915	0.002630	0.000630
4	0.000902	0.002304	0.000721
5	0.000938	0.002591	0.000886
6	0.000993	0.002511	0.001045
7	0.001041	0.002646	0.001200
8	0.000923	0.002231	0.001467
9	0.001001	0.002083	0.001303
10	0.000993	0.001981	0.001446
11	0.001077	0.002057	0.001697
12	0.001001	0.001965	0.001694
13	0.000910	0.001789	0.002016
14	0.000964	0.001847	0.002096
15	0.001191	0.001910	0.002188
16	0.001089	0.001796	0.002391
17	0.001052	0.001757	0.002693
18	0.001199	0.001881	0.002556
19	0.001180	0.002073	0.002626
20	0.001498	0.002167	0.002843
21	0.001094	0.002330	0.002847
22	0.001165	0.002112	0.003406

Test Cylinder No. 8, Unflawed, +60° Wrap Angle, Position B
Displacements: U1 at 0°, U1 at 80°, U2 at 40° (in.)

DATA NO.	U10(I)	U180(I)	U2(I)
1	0.001112	0.002501	0.000335
2	0.001127	0.002582	0.000335
3	0.000942	0.002329	0.000335
4	0.000896	0.002620	0.000385
5	0.000963	0.002745	0.000605
6	0.000870	0.002528	0.000718
7	0.000878	0.002283	0.000803
8	0.000872	0.002241	0.001035
9	0.000834	0.002454	0.001187
10	0.000963	0.002245	0.001354
11	0.000844	0.002276	0.001503
12	0.001174	0.002304	0.001528
13	0.001373	0.002311	0.001727
14	0.001280	0.002571	0.001885
15	0.001078	0.002378	0.002068
16	0.001065	0.002450	0.002245
17	0.001023	0.002355	0.002704
18	0.000992	0.002235	0.002707
19	0.000914	0.002373	0.002347
20	0.000982	0.002373	0.002854
21	0.000926	0.002263	0.002708
22	0.000976	0.002633	0.003017
23	0.001221	0.002238	0.003641

Test Cylinder No. 8, Unflawed, +60° Wrap Angle, Position C
Displacements: U1 at 0°, U1 at 80°, U2 at 40° (in.)

DATA NO.	U10(I)	U180(I)	U2(I)
1	0.001228	0.001920	0.000328
2	0.001182	0.001776	0.000328
3	0.001043	0.001846	0.000321
4	0.001015	0.001920	0.000512
5	0.000995	0.001946	0.000676
6	0.001042	0.001718	0.000824
7	0.000963	0.001483	0.000851
8	0.001037	0.001654	0.001088
9	0.000872	0.001622	0.001281
10	0.001013	0.001664	0.001370
11	0.000970	0.001353	0.001552
12	0.001025	0.001472	0.001676
13	0.001094	0.001767	0.001820
14	0.001009	0.001413	0.001956
15	0.001078	0.001478	0.002640
16	0.001239	0.001312	0.002400
17	0.001115	0.001278	0.002400
18	0.001169	0.001365	0.002854
19	0.001101	0.001646	0.002640
20	0.001302	0.001692	0.003106
21	0.001395	0.001099	0.003017
22	0.001113	0.001488	0.003406
23	0.001129	0.001245	0.003406

Test Cylinder No. 9, Unflawed, +60° Wrap Angle, Position A
Displacements: U1 at 0°, U1 at 80°, U2 at 40° (in.)

DATA NO.	U10(I)	U180(I)	U2(I)
1	0.001519	0.001760	0.000332
2	0.001600	0.001618	0.000332
3	0.001332	0.001857	0.000391
4	0.001313	0.001790	0.000754
5	0.001393	0.001946	0.000754
6	0.001399	0.001804	0.000873
7	0.001240	0.001994	0.001187
8	0.001348	0.002067	0.001200
9	0.001223	0.001829	0.001304
10	0.001498	0.001660	0.001408
11	0.001440	0.001798	0.002030
12	0.001414	0.002096	0.001702
13	0.001682	0.002145	0.001818
14	0.001915	0.002207	0.002111
15	0.001872	0.001946	0.002200
16	0.001732	0.002251	0.002200
17	0.001582	0.001767	0.002347
18	0.001678	0.002235	0.002456
19	0.001806	0.001930	0.002708
20	0.001826	0.002073	0.003017
21	0.001661	0.002715	0.003200
22	0.001687	0.002658	0.003300
23	0.001643	0.002013	0.002708

Test Cylinder No. 9, Unflawed, $\pm 60^\circ$ Wrap Angle, Position B
Displacements: U1 at 0° , U1 at 80° , U2 at 40° (in.)

DATA NO.	U10(I)	U180(I)	U2(I)
1	0.000406	0.002296	0.000320
2	0.001067	0.002634	0.000361
3	0.001351	0.002402	0.000334
4	0.000989	0.002429	0.000436
5	0.001255	0.002336	0.000563
6	0.001329	0.002124	0.000856
7	0.001094	0.002345	0.000923
8	0.001207	0.002407	0.000974
9	0.001222	0.002239	0.001111
10	0.001104	0.002559	0.001435
11	0.001161	0.002480	0.001576
12	0.001135	0.002575	0.001465
13	0.001227	0.002858	0.001561
14	0.001324	0.002133	0.001830
15	0.001409	0.002696	0.001948
16	0.001181	0.002609	0.002245
17	0.001119	0.002575	0.002069
18	0.001263	0.002575	0.002345
19	0.001509	0.002409	0.002574
20	0.001416	0.002620	0.002638
21	0.001206	0.002524	0.002706
22	0.001416	0.002715	0.002854
23	0.001594	0.002648	0.002933

Test Cylinder No. 9, Unflawed, +60° Wrap Angle, Position C
Displacements: U1 at 0°, U1 at 80°, U2 at 40° (in.)

DATA NO.	U10(I)	U180(I)	U2(I)
1	0.001624	0.002023	0.000325
2	0.001288	0.002693	0.000315
3	0.001529	0.002450	0.000352
4	0.001081	0.002391	0.000413
5	0.001196	0.002481	0.000559
6	0.001203	0.002481	0.000857
7	0.000935	0.002858	0.000836
8	0.001172	0.002742	0.001054
9	0.001095	0.002472	0.001223
10	0.001243	0.002858	0.001300
11	0.001170	0.002634	0.001476
12	0.001141	0.002703	0.001598
13	0.001222	0.003048	0.001917
14	0.001119	0.002208	0.001909
15	0.000948	0.003139	0.002023
16	0.001349	0.002528	0.002200
17	0.001346	0.002208	0.002112
18	0.001352	0.002409	0.002514
19	0.001389	0.002667	0.002707
20	0.001703	0.002566	0.002640
21	0.001163	0.002828	0.002854
22	0.001221	0.003149	0.002779
23	0.001186	0.002828	0.003406

Test Cylinder No. 10, Unflawed, $+60^\circ$ Wrap Angle, Position A
Displacements: U1 at 0° , U1 at 80° , U2 at 40° (in.)

DATA NO.	U10(I)	U180(I)	U2(I)
1	0.000799	0.001829	0.000667
2	0.000933	0.002225	0.000671
3	0.000967	0.002009	0.000465
4	0.000980	0.001845	0.000326
5	0.000977	0.002152	0.000266
6	0.000838	0.001920	0.000144
7	0.000918	0.002031	0.000318
8	0.000981	0.001926	0.000383
9	0.000814	0.001872	0.000586
10	0.000770	0.001711	0.000417
11	0.000722	0.001544	0.000638
12	0.000934	0.001703	0.000918
13	0.000889	0.001622	0.001067
14	0.000848	0.001618	0.001228
15	0.001131	0.001539	0.001257
16	0.000903	0.001659	0.001650
17	0.001017	0.001556	0.001509
18	0.000989	0.001385	0.001553
19	0.001056	0.001858	0.002031
20	0.000926	0.001411	0.002246
21	0.001063	0.002038	0.002343
22	0.001157	0.001731	0.002513
23	0.001069	0.001865	0.002400

Test Cylinder No. 10, Unflawed, +60° Wrap Angle, Position B
Displacements: U1 at 0°, U1 at 80°, U2 at 40° (in.)

DATA NO.	U10(I)	U180(I)	U2(I)
1	0.000852	0.002040	0.000521
2	0.000841	0.002122	0.000442
3	0.000794	0.001867	0.000215
4	0.000812	0.001955	0.000245
5	0.000776	0.002028	0.000158
6	0.000666	0.002091	0.000280
7	0.001829	0.001793	0.000321
8	0.000632	0.002429	0.000547
9	0.000682	0.002025	0.000670
10	0.000569	0.002209	0.000765
11	0.000556	0.002036	0.000902
12	0.000365	0.001942	0.001030
13	0.000359	0.001891	0.001236
14	0.000373	0.002799	0.001471
15	0.000244	0.002403	0.001471
16	0.000287	0.002218	0.001575
17	0.000316	0.002280	0.001654
18	0.000290	0.002522	0.001741
19	0.000247	0.003236	0.002009
20	0.000280	0.002803	0.002049
21	0.000263	0.002617	0.002066
22	0.000387	0.002401	0.002511
23	0.000357	0.002718	0.002544

Test Cylinder No. 10, Unflawed, +60° Wrap Angle, Position C
Displacements: U1 at 0°, U1 at 80°, U2 at 40° (in.)

DATA NO.	U10(I)	U180(I)	U2(I)
1	0.000888	0.002025	0.000313
2	0.000966	0.002009	0.000313
3	0.000844	0.001819	0.000313
4	0.000815	0.001931	0.000286
5	0.000811	0.002607	0.000331
6	0.000653	0.002179	0.000331
7	0.000633	0.002207	0.000536
8	0.000649	0.001920	0.000682
9	0.000722	0.001944	0.000894
10	0.000660	0.001953	0.000994
11	0.000590	0.002163	0.001156
12	0.000583	0.002110	0.001253
13	0.000686	0.002109	0.001420
14	0.000557	0.002104	0.001524
15	0.000638	0.002074	0.001614
16	0.000583	0.002373	0.001633
17	0.000653	0.001996	0.001851
18	0.000630	0.002144	0.002080
19	0.000662	0.002279	0.002125
20	0.000448	0.002389	0.002338
21	0.000728	0.002524	0.002582
22	0.000609	0.002770	0.003059
23	0.000545	0.002243	0.002811

Test Cylinder No. 11, Flawed, $\pm 60^\circ$ Wrap Angle, Position A
Displacements: U1 at 0° , U1 at 80° , U2 at 40° (in.)

DATA NO.	U10(I)	U180(I)	U2(I)
1	0.001190	0.000302	0.001038
2	0.001114	0.003188	0.001210
3	0.000977	0.002914	0.001437
4	0.001101	0.002848	0.001803
5	0.001056	0.002883	0.001952
6	0.000616	0.003163	0.002255
7	0.000619	0.003373	0.002209
8	0.000693	0.003985	0.002496
9	0.000796	0.003798	0.002550
10	0.000719	0.002766	0.003332
11	0.000798	0.002987	0.003118
12	0.000646	0.002881	0.003778
13	0.000990	0.002828	0.003689
14	0.000775	0.003394	0.004160
15	0.000612	0.003028	0.004132
16	0.000668	0.002884	0.005504
17	0.000612	0.003232	0.005229
18	0.000700	0.003085	0.005456
19	0.000919	0.002423	0.006117
20	0.001292	0.003719	0.006188
21	0.001156	0.003106	0.007001
22	0.001708	0.003028	0.006203
23	0.001292	0.002753	0.005859

Test Cylinder No. 11, Flawed, +45° Wrap Angle, Position B
Displacements: U1 at 0°, U1 at 80°, U2 at 40° (in.)

DATA NO.	U10(I)	U180(I)	U2(I)
1	0.000932	0.001389	0.000491
2	0.001046	0.001276	0.000651
3	0.000857	0.001306	0.000892
4	0.000900	0.001300	0.001063
5	0.000867	0.001371	0.001213
6	0.000940	0.001383	0.001389
7	0.000866	0.001329	0.001522
8	0.001007	0.001570	0.001758
9	0.000992	0.001382	0.001920
10	0.000911	0.001442	0.002030
11	0.000752	0.001399	0.002247
12	0.000946	0.001427	0.002296
13	0.000860	0.001512	0.002346
14	0.000816	0.001696	0.002391
15	0.000710	0.001590	0.002933
16	0.000908	0.001502	0.002575
17	0.000882	0.001653	0.002852
18	0.000798	0.001389	0.003104
19	0.000781	0.001642	0.003402
20	0.000976	0.001255	0.003406
21	0.000742	0.001577	0.003518
22	0.000844	0.001642	0.003636

Test Cylinder No. 11, Flawed, +45° Wrap Angle, Position C
Displacements: U1 at 0°, U1 at 80°, U2 at 40° (in.)

DATA NO.	U10(I)	U180(I)	U2(I)
1	0.003394	0.002000	0.000496
2	0.000822	0.001860	0.000739
3	0.000822	0.001760	0.000903
4	0.000766	0.001793	0.001003
5	0.000834	0.001866	0.001240
6	0.000787	0.001828	0.001401
7	0.000648	0.001914	0.001405
8	0.000799	0.001899	0.001630
9	0.000733	0.001915	0.001682
10	0.000795	0.001899	0.001982
11	0.000695	0.001812	0.001948
12	0.000680	0.001786	0.002066
13	0.000606	0.001886	0.002338
14	0.000566	0.002032	0.002737
15	0.000787	0.001940	0.002811
16	0.000594	0.001970	0.002768
17	0.000759	0.001999	0.003001
18	0.000545	0.001594	0.003010
19	0.000545	0.001653	0.003275
20	0.000630	0.002332	0.003373
21	0.000848	0.002301	0.003614
22	0.000650	0.002200	0.004031
23	0.000844	0.002112	0.004183

Test Cylinder No. 12, Flawed, +45° Wrap Angle, Position A
Displacements: U1 at 0°, U1 at 80°, U2 at 40° (in.)

DATA NO.	U10(I)	U180(I)	U2(I)
1	0.001029	0.001772	0.000748
2	0.001110	0.001865	0.000591
3	0.001332	0.002082	0.000455
4	0.001280	0.002134	0.000365
5	0.001152	0.002096	0.000345
6	0.001020	0.002247	0.000345
7	0.001119	0.001941	0.000344
8	0.001037	0.002011	0.000344
9	0.001133	0.002230	0.000467
10	0.001157	0.001895	0.000584
11	0.001172	0.001942	0.000684
12	0.000977	0.001847	0.000897
13	0.000923	0.002260	0.001043
14	0.001082	0.001984	0.001187
15	0.001283	0.001988	0.001316
16	0.001215	0.001722	0.001324
17	0.001217	0.001935	0.001580
18	0.001065	0.002018	0.001714
19	0.001119	0.001899	0.001926
20	0.001006	0.001939	0.002147
21	0.001115	0.002235	0.002213
22	0.000695	0.001800	0.002039
23	0.000926	0.001939	0.002377

Test Cylinder No. 12, Flawed, +45° Wrap Angle, Position B
Displacements: U1 at 0°, U1 at 80°, U2 at 40° (in.)

DATA NO.	U10(I)	U180(I)	U2(I)
1	0.001253	0.001484	0.000475
2	0.001227	0.001581	0.000424
3	0.001398	0.001579	0.000380
4	0.001301	0.001268	0.000315
5	0.001147	0.001200	0.000325
6	0.001209	0.001288	0.000373
7	0.001215	0.001405	0.000373
8	0.001188	0.001202	0.000373
9	0.001110	0.001072	0.000433
10	0.001244	0.001167	0.000617
11	0.001317	0.001580	0.000774
12	0.001205	0.001364	0.000967
13	0.001189	0.001435	0.001043
14	0.001178	0.001445	0.001301
15	0.001234	0.001461	0.001384
16	0.001121	0.001440	0.001527
17	0.001017	0.001667	0.001985
18	0.001076	0.001589	0.002107
19	0.001373	0.001859	0.002155
20	0.001250	0.001599	0.002346
21	0.001148	0.001743	0.002708
22	0.001180	0.002130	0.002640
23	0.001141	0.001737	0.002779

Test Cylinder No. 12, Flawed, +45° Wrap Angle, Position C
Displacements: U1 at 0°, U1 at 80°, U2 at 40° (in.)

DATA NO.	U10(I)	U180(I)	U2(I)
1	0.001062	0.001841	0.000392
2	0.001122	0.001926	0.000361
3	0.001341	0.002400	0.000245
4	0.001030	0.002134	0.000223
5	0.001111	0.002011	0.000317
6	0.000948	0.002134	0.000362
7	0.000775	0.002000	0.000460
8	0.000733	0.001895	0.000569
9	0.000861	0.002009	0.000722
10	0.000894	0.001931	0.000871
11	0.000789	0.001710	0.001009
12	0.000815	0.001664	0.001305
13	0.000800	0.001818	0.001323
14	0.000741	0.002345	0.001408
15	0.000555	0.001947	0.001504
16	0.000544	0.001721	0.001637
17	0.000719	0.002074	0.002072
18	0.000826	0.002018	0.002073
19	0.000772	0.002074	0.002213
20	0.000677	0.002096	0.002311
21	0.000860	0.001996	0.002476
22	0.000854	0.002190	0.002490
23	0.000798	0.002373	0.002764

Test Cylinder No. 13, Flawed, +45° Wrap Angle, Position A
Displacements: U1 at 0°, U1 at 80°, U2 at 40° (in.)

DATA NO.	U10(I)	U180(I)	U2(I)
1	0.001244	0.001139	0.000701
2	0.001211	0.000912	0.000640
3	0.001339	0.000701	0.000501
4	0.001329	0.000825	0.000429
5	0.001072	0.000885	0.000360
6	0.001064	0.000936	0.000334
7	0.000944	0.000896	0.000335
8	0.001042	0.000800	0.000335
9	0.001287	0.000668	0.000146
10	0.001288	0.000685	0.000246
11	0.001092	0.000684	0.000294
12	0.001264	0.000822	0.000324
13	0.001275	0.000811	0.000394
14	0.001215	0.000740	0.000534
15	0.001340	0.000693	0.000644
16	0.001460	0.000707	0.000826
17	0.001378	0.000642	0.000854
18	0.001181	0.000647	0.000936
19	0.001412	0.000514	0.001104
20	0.001863	0.000541	0.001172
21	0.001435	0.000549	0.001230
22	0.001685	0.000549	0.001327
23	0.001626	0.000494	0.001378

Test Cylinder No. 13, Flawed, +45° Wrap Angle, Position B
Displacements: U1 at 0°, U1 at 80°, U2 at 40° (in.)

DATA NO.	U10(I)	U180(I)	U2(I)
1	0.001215	0.001473	0.000285
2	0.001162	0.001387	0.000285
3	0.001135	0.001310	0.000285
4	0.001135	0.001394	0.000285
5	0.001165	0.001522	0.000285
6	0.001092	0.001468	0.000381
7	0.001091	0.001530	0.000491
8	0.001025	0.001507	0.000587
9	0.001055	0.001276	0.000714
10	0.000987	0.001060	0.000850
11	0.001079	0.001050	0.000956
12	0.001156	0.001225	0.001073
13	0.001067	0.001498	0.001167
14	0.001039	0.001198	0.001389
15	0.001055	0.001305	0.001507
16	0.001286	0.001293	0.001594
17	0.001409	0.001119	0.001756
18	0.001332	0.001102	0.001945
19	0.001784	0.000930	0.001875
20	0.001651	0.001023	0.002096
21	0.001512	0.000996	0.002311
22	0.001514	0.000905	0.002411
23	0.001554	0.000607	0.002476

Test Cylinder No. 13, Flawed, +45° Wrap Angle, Position C
Displacements: U1 at 0°, U1 at 80°, U2 at 40° (in.)

DATA NO.	U10(I)	U180(I)	U2(I)
1	0.001579	0.001807	0.000332
2	0.001538	0.001772	0.000408
3	0.001288	0.001610	0.000521
4	0.001259	0.001632	0.000656
5	0.001312	0.001569	0.000765
6	0.001254	0.001412	0.000873
7	0.001335	0.001466	0.000974
8	0.001264	0.001404	0.001200
9	0.001266	0.001539	0.001286
10	0.001309	0.001485	0.001389
11	0.001449	0.001500	0.001551
12	0.001385	0.001262	0.001551
13	0.001267	0.001412	0.001811
14	0.001119	0.001332	0.001915
15	0.001512	0.001514	0.002011
16	0.001704	0.001317	0.002283
17	0.001924	0.000823	0.002179
18	0.001633	0.000837	0.002311
19	0.001737	0.000989	0.002476
20	0.001760	0.001342	0.002607
21	0.001598	0.001498	0.002536
22	0.002322	0.000965	0.003141
23	0.002217	0.000882	0.003259

Test Cylinder No. 14, Flawed, $+45^\circ$ Wrap Angle, Position A
Displacements: U1 at 0° , U1 at 80° , U2 at 40° (in.)

DATA NO.	U10(I)	U180(I)	U2(I)
1	0.001174	0.000962	0.000285
2	0.001507	0.000940	0.000285
3	0.001435	0.000784	0.000378
4	0.001378	0.000777	0.000477
5	0.001248	0.000817	0.000601
6	0.001341	0.000678	0.000684
7	0.001230	0.000737	0.000767
8	0.001256	0.000818	0.000868
9	0.001305	0.000810	0.001006
10	0.001484	0.000680	0.001130
11	0.001368	0.000638	0.001348
12	0.001409	0.000582	0.001497
13	0.001438	0.000670	0.001524
14	0.001200	0.000573	0.001747
15	0.001595	0.000583	0.001896
16	0.001442	0.000475	0.001949
17	0.001697	0.000448	0.002000
18	0.001385	0.000426	0.002129
19	0.001672	0.000426	0.002324
20	0.001476	0.000283	0.002295
21	0.001924	0.000458	0.002737
22	0.001940	0.000413	0.002911
23	0.001648	0.000408	0.002737

AD-A069 191

ARMY MISSILE RESEARCH AND DEVELOPMENT COMMAND REDSTO--ETC F/G 20/11
DETERMINATION OF ELASTIC CONSTANTS FOR FLAWED AND UNFLAWED COMP--ETC(U)
MAR 79 T L VANDIVER

UNCLASSIFIED

DRDMI-T-79-36

NL

2 OF 2
AD A069191

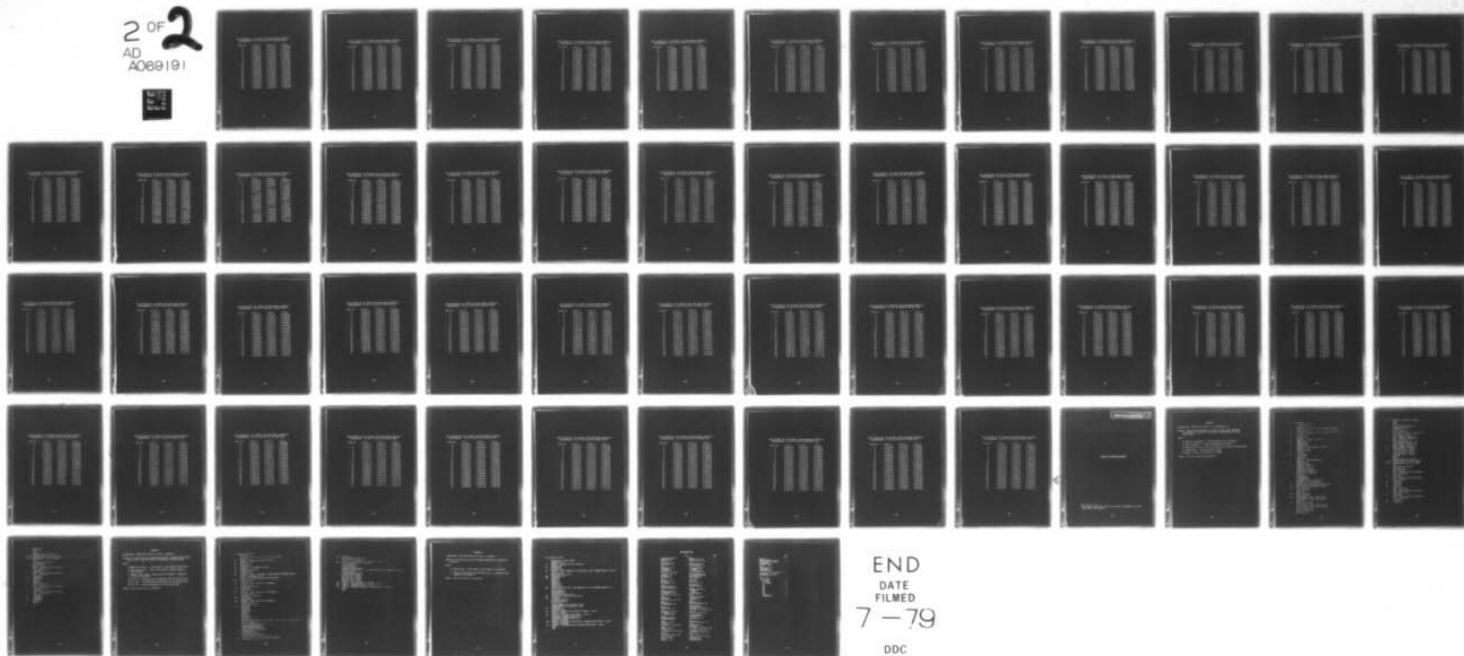

END
DATE
FILMED
7-79
DDC



Test Cylinder No. 14, Flawed, +45° Wrap Angle, Position B
Displacements: U1 at 0°, U1 at 80°, U2 at 40° (in.)

DATA NO.	U10(I)	U180(I)	U2(I)
1	0.001159	0.001215	0.000293
2	0.001217	0.001329	0.000433
3	0.001167	0.001006	0.000577
4	0.001336	0.000783	0.000690
5	0.001006	0.000878	0.000859
6	0.000941	0.000987	0.000959
7	0.000862	0.000962	0.000921
8	0.000929	0.000830	0.000951
9	0.001085	0.000733	0.001056
10	0.001471	0.000751	0.001389
11	0.001356	0.000720	0.001272
12	0.001556	0.000797	0.001618
13	0.001438	0.000714	0.001909
14	0.001187	0.000695	0.001909
15	0.001188	0.000606	0.002020
16	0.001385	0.000547	0.002080
17	0.001478	0.000569	0.002324
18	0.001438	0.000407	0.002167
19	0.001554	0.000563	0.002483
20	0.001475	0.000578	0.002591
21	0.001797	0.000459	0.002671
22	0.002109	0.000325	0.002708
23	0.002658	0.000307	0.002879

Test Cylinder No. 14, Flawed, +45° Wrap Angle, Position C
Displacements: U1 at 0°, U1 at 80°, U2 at 40° (in.)

DATA NO.	U10(I)	U180(I)	U2(I)
1	0.001237	0.001079	0.000295
2	0.001403	0.000792	0.000295
3	0.001301	0.000721	0.000448
4	0.001323	0.000715	0.000642
5	0.001340	0.000734	0.000700
6	0.001220	0.000721	0.000820
7	0.001201	0.000730	0.000932
8	0.001107	0.000682	0.000926
9	0.001264	0.000701	0.001059
10	0.001406	0.000617	0.001233
11	0.001287	0.000466	0.001312
12	0.001356	0.000412	0.001500
13	0.001500	0.000433	0.001763
14	0.001606	0.000551	0.001634
15	0.001579	0.000625	0.001811
16	0.001582	0.000506	0.001816
17	0.001616	0.000568	0.001956
18	0.001823	0.000458	0.002039
19	0.001711	0.000437	0.002080
20	0.001438	0.000549	0.002324
21	0.001749	0.000563	0.002626
22	0.001760	0.000483	0.002607
23	0.002719	0.000387	0.002600

Test Cylinder No. 15, Unflawed, +45° Wrap Angle, Position A
Displacements: U1 at 0°, U1 at 80°, U2 at 40° (in.)

DATA NO.	U10(I)	U180(I)	U2(I)
1	0.001088	0.000921	0.000384
2	0.000914	0.000992	0.000471
3	0.000920	0.001069	0.000559
4	0.000863	0.001147	0.000645
5	0.000879	0.001106	0.000738
6	0.000892	0.001067	0.000819
7	0.000965	0.001085	0.000955
8	0.001019	0.001146	0.001129
9	0.001072	0.001140	0.001286
10	0.000963	0.001242	0.001294
11	0.000928	0.001332	0.001353
12	0.000933	0.001278	0.001591
13	0.000890	0.001385	0.001646
14	0.001102	0.001445	0.001780
15	0.001077	0.001382	0.001722
16	0.001077	0.001369	0.001978
17	0.001115	0.001219	0.002104
18	0.000946	0.001360	0.002438
19	0.001130	0.001431	0.002446
20	0.000905	0.001506	0.002574
21	0.000905	0.001549	0.002513
22	0.001364	0.001700	0.002704
23	0.001364	0.001447	0.002708

Test Cylinder No. 15, Unflawed, $+45^\circ$ Wrap Angle, Position B
Displacements: U1 at 0° , U1 at 80° , U2 at 40° (in.)

DATA NO.	U10(I)	U180(I)	U2(I)
1	0.001260	0.001056	0.000361
2	0.001064	0.000880	0.000416
3	0.001096	0.001006	0.000567
4	0.001104	0.000972	0.000666
5	0.001080	0.001042	0.000788
6	0.000925	0.001108	0.000953
7	0.001030	0.000918	0.001021
8	0.000955	0.000970	0.001142
9	0.001091	0.001038	0.001230
10	0.001044	0.000848	0.001444
11	0.001049	0.001070	0.001413
12	0.001165	0.001027	0.001500
13	0.001166	0.000926	0.001561
14	0.001110	0.001065	0.001697
15	0.000879	0.000908	0.002192
16	0.000879	0.001038	0.001990
17	0.000693	0.000926	0.002324
18	0.000753	0.000992	0.002108
19	0.000837	0.000965	0.002091
20	0.001275	0.001130	0.002513
21	0.001163	0.000965	0.002400
22	0.000960	0.000950	0.002707
23	0.001481	0.001023	0.002706

Test Cylinder No. 15, Unflawed, +45° Wrap Angle, Position C
Displacements: U1 at 0°, U1 at 80°, U2 at 40° (in.)

DATA NO.	U10(I)	U180(I)	U2(I)
1	0.000894	0.001002	0.000343
2	0.000839	0.001255	0.000405
3	0.000686	0.001180	0.000515
4	0.000659	0.001049	0.000642
5	0.000638	0.001261	0.000807
6	0.000770	0.001169	0.000872
7	0.000825	0.001119	0.000954
8	0.000796	0.001108	0.001174
9	0.000767	0.001164	0.001214
10	0.000698	0.001309	0.001354
11	0.000775	0.001334	0.001435
12	0.000747	0.001236	0.001415
13	0.000773	0.001056	0.001512
14	0.000890	0.001241	0.001552
15	0.000826	0.001342	0.001937
16	0.000695	0.001478	0.002167
17	0.000795	0.001389	0.002329
18	0.000842	0.001180	0.002000
19	0.000718	0.001435	0.002324
20	0.000718	0.001553	0.002213
21	0.000926	0.001954	0.002446
22	0.000834	0.001539	0.002511
23	0.000777	0.001236	0.002704

Test Cylinder No. 16, Unflawed, $+45^\circ$ Wrap Angle, Position A
Displacements: U1 at 0° , U1 at 80° , U2 at 40° (in.)

DATA NO.	U10(I)	U180(I)	U2(I)
1	0.000987	0.001422	0.000373
2	0.000941	0.001234	0.000421
3	0.001026	0.001040	0.000406
4	0.001063	0.001060	0.000668
5	0.000943	0.001081	0.000825
6	0.000993	0.001105	0.000838
7	0.000945	0.001041	0.001067
8	0.001004	0.001023	0.001148
9	0.001114	0.000956	0.001214
10	0.001075	0.000740	0.001570
11	0.001084	0.000628	0.001625
12	0.001070	0.000783	0.001616
13	0.001065	0.000935	0.001621
14	0.000992	0.000855	0.001913
15	0.001191	0.000930	0.002023
16	0.001012	0.000945	0.001883
17	0.001280	0.000772	0.002329
18	0.001342	0.001038	0.002096
19	0.001327	0.000880	0.002442
20	0.001127	0.000860	0.002556
21	0.001296	0.000903	0.002501
22	0.001370	0.000787	0.002838
23	0.001187	0.000470	0.002911
24	0.001144	0.000283	0.002638

Test Cylinder No. 16, Unflawed, $+45^\circ$ Wrap Angle, Position B
Displacements: U1 at 0° , U1 at 80° , U2 at 40° (in.)

DATA NO.	U10(I)	U180(I)	U2(I)
1	0.001272	0.001238	0.000347
2	0.001039	0.001298	0.000431
3	0.001095	0.001100	0.000569
4	0.000938	0.001054	0.000629
5	0.001009	0.001033	0.000771
6	0.000957	0.001046	0.000910
7	0.000930	0.001052	0.000969
8	0.000970	0.001087	0.001187
9	0.001025	0.001016	0.001257
10	0.000932	0.000932	0.001509
11	0.000965	0.000928	0.001509
12	0.001174	0.000965	0.001600
13	0.000953	0.001078	0.001650
14	0.000756	0.001046	0.001760
15	0.000945	0.001153	0.001886
16	0.001209	0.001228	0.002031
17	0.001141	0.000752	0.002247
18	0.001065	0.000816	0.002296
19	0.001169	0.000739	0.002706
20	0.001032	0.000642	0.002640
21	0.001115	0.000882	0.002640
22	0.000901	0.000908	0.002933
23	0.000840	0.000787	0.003017

Test Cylinder No. 16, Unflawed, $+45^\circ$ Wrap Angle, Position C
Displacements: U1 at 0° , U1 at 80° , U2 at 40° (in.)

DATA NO.	U10(I)	U180(I)	U2(I)
1	0.000919	0.002031	0.000357
2	0.000943	0.001600	0.000441
3	0.000864	0.001435	0.000640
4	0.000821	0.001627	0.000703
5	0.000839	0.001643	0.000818
6	0.000752	0.001608	0.000929
7	0.000739	0.001435	0.001067
8	0.000856	0.001286	0.001200
9	0.000963	0.001266	0.001288
10	0.000926	0.001215	0.001287
11	0.000943	0.000948	0.001366
12	0.000776	0.001150	0.001821
13	0.000910	0.001332	0.001919
14	0.001076	0.001020	0.001992
15	0.001102	0.001102	0.002104
16	0.001065	0.000920	0.002241
17	0.001077	0.000899	0.002634
18	0.001063	0.001041	0.002394
19	0.000976	0.000903	0.002591
20	0.000882	0.000882	0.002850
21	0.000950	0.000858	0.002697
22	0.000903	0.000856	0.002697
23	0.000882	0.000996	0.002993

Test Cylinder No. 17, Unflawed, $+45^\circ$ Wrap Angle, Position A
Displacements: U1 at 0° , U1 at 80° , U2 at 40° (in.)

DATA NO.	U10(I)	U180(I)	U2(1)
1	0.000771	0.001992	0.000326
2	0.000714	0.001793	0.000442
3	0.000718	0.001872	0.000642
4	0.000686	0.001895	0.000708
5	0.000597	0.001826	0.000818
6	0.000554	0.001654	0.000981
7	0.000525	0.001809	0.001165
8	0.000590	0.002045	0.001202
9	0.000648	0.001905	0.001288
10	0.000675	0.001364	0.001337
11	0.000723	0.001548	0.001427
12	0.000625	0.001771	0.001676
13	0.000733	0.001757	0.002031
14	0.000681	0.001575	0.002071
15	0.000532	0.001301	0.002155
16	0.000737	0.001307	0.002112
17	0.000728	0.001512	0.002247
18	0.000540	0.001458	0.002708
19	0.000477	0.001431	0.002708
20	0.000627	0.001646	0.002933
21	0.000627	0.001467	0.003300
22	0.000672	0.001754	0.002708
23	0.000578	0.001498	0.003106

Test Cylinder No. 17, Unflawed, +45° Wrap Angle, Position B
Displacements: U1 at 0°, U1 at 80°, U2 at 40° (in.)

DATA NO.	U10(I)	U180(I)	U2(I)
1	0.001113	0.001403	0.000325
2	0.000962	0.001154	0.000428
3	0.000943	0.001259	0.000550
4	0.000923	0.001580	0.000718
5	0.000808	0.001604	0.000819
6	0.000683	0.001444	0.000951
7	0.000677	0.001518	0.001067
8	0.000834	0.001454	0.001214
9	0.000721	0.001509	0.001320
10	0.000638	0.001140	0.001427
11	0.000591	0.001385	0.001553
12	0.000711	0.001659	0.001624
13	0.000485	0.001643	0.001522
14	0.000628	0.001747	0.001727
15	0.000424	0.001723	0.001883
16	0.000399	0.001800	0.002069
17	0.000403	0.001731	0.002069
18	0.000337	0.001553	0.002154
19	0.000667	0.001939	0.002345
20	0.000579	0.001596	0.002343
21	0.000399	0.001554	0.002772
22	0.000342	0.001835	0.002775
23	0.000524	0.001757	0.003006

Test Cylinder No. 17, Unflawed, +45° Wrap Angle, Position C
Displacements: U1 at 0°, U1 at 80°, U2 at 40° (in.)

DATA NO.	U10(I)	U180(I)	U2(I)
1	0.000302	0.001437	0.000422
2	0.001110	0.001209	0.000422
3	0.001123	0.001153	0.000652
4	0.001122	0.001201	0.000782
5	0.001081	0.001140	0.000880
6	0.001124	0.001124	0.000969
7	0.001109	0.001226	0.001067
8	0.001117	0.001187	0.001187
9	0.001077	0.001095	0.001288
10	0.001089	0.001141	0.001427
11	0.001237	0.001177	0.001530
12	0.001155	0.001305	0.001650
13	0.001046	0.001027	0.001625
14	0.001148	0.001241	0.002071
15	0.001045	0.001508	0.002112
16	0.001113	0.001327	0.002071
17	0.000978	0.001102	0.002155
18	0.000945	0.001229	0.002400
19	0.001078	0.001179	0.002514
20	0.001187	0.001599	0.002296
21	0.000860	0.001703	0.002576
22	0.000976	0.001599	0.002854
23	0.000905	0.001653	0.002708

Test Cylinder No. 18, Unflawed, +45° Wrap Angle, Position A
Displacements: U1 at 0°, U1 at 80°, U2 at 40° (in.)

DATA NO.	U10(I)	U180(I)	U2(I)
1	0.001214	0.002031	0.000324
2	0.001272	0.002031	0.000374
3	0.001167	0.002528	0.000543
4	0.001137	0.002139	0.000634
5	0.001148	0.002067	0.000759
6	0.001140	0.001828	0.000843
7	0.001189	0.002012	0.001038
8	0.001087	0.001743	0.001087
9	0.001027	0.001652	0.001193
10	0.001151	0.001651	0.001386
11	0.000970	0.001594	0.001551
12	0.000812	0.001765	0.001785
13	0.000827	0.001583	0.001701
14	0.000953	0.001778	0.001982
15	0.000918	0.001884	0.002111
16	0.001024	0.001737	0.002446
17	0.000970	0.001767	0.001948
18	0.000805	0.001509	0.002016
19	0.000757	0.001435	0.002446
20	0.001063	0.001244	0.002505
21	0.000881	0.001553	0.002450
22	0.000970	0.001718	0.002701
23	0.000903	0.001514	0.002569

Test Cylinder No. 18, Unflawed, +45° Wrap Angle, Position B
Displacements: U1 at 0°, U1 at 80°, U2 at 40° (in).

DATA NO.	U10(I)	U180(I)	U2(I)
1	0.001141	0.001318	0.000329
2	0.001260	0.001703	0.000335
3	0.001196	0.001406	0.000401
4	0.000911	0.001029	0.000424
5	0.000879	0.001409	0.000580
6	0.000783	0.001480	0.000754
7	0.000926	0.001407	0.000895
8	0.000956	0.001001	0.001025
9	0.001150	0.001023	0.001187
10	0.001307	0.000992	0.001467
11	0.000921	0.001077	0.001447
12	0.000922	0.001241	0.001530
13	0.001142	0.001356	0.001676
14	0.001026	0.001289	0.001821
15	0.001142	0.001267	0.001992
16	0.000978	0.001100	0.001992
17	0.000911	0.001138	0.001992
18	0.000880	0.001038	0.002456
19	0.000788	0.001271	0.002200
20	0.000882	0.001144	0.002514
21	0.000839	0.000989	0.002708
22	0.000653	0.001835	0.002576
23	0.000653	0.001781	0.002933

Test Cylinder No. 18, Unflawed, +45° Wrap Angle, Position C
Displacements: U1 at 0°, U1 at 80°, U2 at 40° (in.)

DATA NO.	U10(I)	U180(I)	U2(I)
1	0.001196	0.001427	0.000375
2	0.001139	0.001522	0.000446
3	0.001119	0.001646	0.000551
4	0.001093	0.001933	0.000667
5	0.001015	0.001908	0.000754
6	0.000993	0.001518	0.000918
7	0.001073	0.001664	0.000969
8	0.000949	0.001828	0.001035
9	0.000891	0.001570	0.001371
10	0.001025	0.001309	0.001406
11	0.001001	0.001204	0.001461
12	0.001088	0.001327	0.001525
13	0.000885	0.001413	0.001820
14	0.000676	0.001414	0.001820
15	0.000746	0.001667	0.001990
16	0.000895	0.001630	0.002069
17	0.000982	0.001616	0.002154
18	0.000982	0.001514	0.002199
19	0.000805	0.001643	0.002513
20	0.000746	0.001637	0.002505
21	0.000792	0.001389	0.002697
22	0.000625	0.001549	0.002701
23	0.000728	0.001352	0.002697

Test Cylinder No. 19, Unflawed, $\pm 45^\circ$ Wrap Angle, Position A
Displacements: U1 at 0° , U1 at 80° , U2 at 40° (in.)

DATA NO.	U10(I)	U180(I)	U2(I)
1	0.001295	0.002012	0.000488
2	0.001371	0.001820	0.000380
3	0.001180	0.002459	0.000332
4	0.001159	0.001772	0.000349
5	0.001045	0.001609	0.000349
6	0.001241	0.001452	0.000349
7	0.001152	0.001272	0.000349
8	0.001268	0.001503	0.000353
9	0.001046	0.001645	0.000374
10	0.001083	0.001895	0.000440
11	0.001167	0.001650	0.000502
12	0.001276	0.001507	0.000654
13	0.001329	0.001544	0.000793
14	0.001051	0.001347	0.000933
15	0.001246	0.001765	0.000977
16	0.001246	0.001600	0.001066
17	0.001330	0.001570	0.001283
18	0.001413	0.001331	0.001439
19	0.001171	0.001236	0.001522
20	0.001354	0.001174	0.001596
21	0.001442	0.001327	0.001702
22	0.001406	0.001513	0.001790
23	0.001284	0.001301	0.001803

Test Cylinder No. 19, Unflawed, +45° Wrap Angle, Position B
Displacements: U1 at 0°, U1 at 80°, U2 at 40° (in.)

DATA NO.	U10(I)	U180(I)	U2(I)
1	0.001097	0.001676	0.000363
2	0.001120	0.001687	0.000419
3	0.001151	0.001759	0.000505
4	0.001195	0.001931	0.000577
5	0.001219	0.001847	0.000737
6	0.001092	0.001688	0.000869
7	0.001090	0.001421	0.001023
8	0.001266	0.001556	0.001040
9	0.001170	0.001498	0.001184
10	0.001548	0.001556	0.001283
11	0.001242	0.001687	0.001307
12	0.001359	0.001385	0.001522
13	0.001250	0.001222	0.001909
14	0.001317	0.001142	0.001747
15	0.001553	0.001262	0.001811
16	0.001512	0.001616	0.001985
17	0.001369	0.001548	0.002028
18	0.001327	0.001320	0.002107
19	0.001130	0.001320	0.002143
20	0.001370	0.001174	0.002188
21	0.001389	0.000970	0.002179
22	0.001416	0.000970	0.002184
23	0.001389	0.000950	0.002490

Test Cylinder No. 19, Unflawed, +45° Wrap Angle, Position C
Displacements: U1 at 0°, U1 at 80°, U2 at 40° (in.)

DATA NO.	U10(I)	U180(I)	U2(I)
1	0.000770	0.001733	0.000342
2	0.000856	0.001672	0.000420
3	0.000896	0.001666	0.000523
4	0.001079	0.001554	0.000584
5	0.000927	0.001648	0.000662
6	0.000930	0.001444	0.000838
7	0.000834	0.001245	0.000969
8	0.001082	0.001395	0.001067
9	0.000990	0.001345	0.001187
10	0.000956	0.001395	0.001288
11	0.000913	0.001509	0.001354
12	0.001106	0.001485	0.001553
13	0.001165	0.001333	0.001625
14	0.001036	0.001240	0.001703
15	0.001158	0.001035	0.001731
16	0.001094	0.001338	0.001992
17	0.001024	0.001301	0.002031
18	0.001239	0.001389	0.002155
19	0.001141	0.001514	0.002200
20	0.001077	0.001354	0.002200
21	0.001102	0.001251	0.002400
22	0.001023	0.001081	0.002640
23	0.000970	0.001147	0.002640

Test Cylinder No. 20, Unflawed, +45° Wrap Angle, Position A
Displacements: U1 at 0°, U1 at 80°, U2 at 40° (in.)

DATA NO.	U10(I)	U180(I)	U2(I)
1	0.000888	0.002104	0.000410
2	0.001194	0.002318	0.000515
3	0.000893	0.001962	0.000648
4	0.000957	0.001895	0.000681
5	0.001006	0.001534	0.000838
6	0.001082	0.000974	0.000951
7	0.001576	0.001060	0.001121
8	0.001140	0.001609	0.001285
9	0.001254	0.002002	0.001368
10	0.001329	0.001550	0.001473
11	0.001250	0.001497	0.001529
12	0.001324	0.001442	0.001677
13	0.001327	0.001512	0.001747
14	0.001513	0.001478	0.001793
15	0.001478	0.001399	0.002122
16	0.001267	0.001399	0.002356
17	0.001399	0.001354	0.002108
18	0.001473	0.001549	0.002116
19	0.001893	0.001262	0.002459
20	0.001600	0.001395	0.002490
21	0.001703	0.001174	0.002681
22	0.001653	0.001221	0.002681
23	0.001653	0.001221	0.002911

Test Cylinder No. 20, Unflawed, +45° Wrap Angle, Position B
 Displacements: U1 at 0°, U1 at 80°, U2 at 40° (in.)

DATA NO.	U10(I)	U180(I)	U2(I)
1	0.000831	0.001307	0.000300
2	0.000853	0.001440	0.000393
3	0.000857	0.001238	0.000483
4	0.000854	0.001246	0.000630
5	0.000777	0.001162	0.000689
6	0.000878	0.001030	0.000782
7	0.000776	0.001058	0.000923
8	0.000949	0.001245	0.001033
9	0.000936	0.001103	0.001180
10	0.000977	0.001022	0.001245
11	0.000935	0.001178	0.001346
12	0.001066	0.001042	0.001452
13	0.001009	0.000798	0.001638
14	0.001106	0.000752	0.001705
15	0.000985	0.000764	0.001672
16	0.001076	0.000976	0.001867
17	0.001115	0.001033	0.002055
18	0.000985	0.000917	0.002279
19	0.001020	0.000880	0.002377
20	0.001228	0.000568	0.002377
21	0.001141	0.000639	0.002370
22	0.001129	0.000950	0.002501
23	0.001101	0.001042	0.002556

Test Cylinder No. 20, Unflawed, +45° Wrap Angle, Position C
 Displacements: U1 at 0°, U1 at 80°, U2 at 40° (in.)

DATA NO.	U10(I)	U180(I)	U2(I)
1	0.000020	0.002125	0.000169
2	0.000007	0.001878	0.000320
3	0.000032	0.001682	0.000625
4	0.000021	0.001838	0.000799
5	0.000000	0.001622	0.000703
6	0.000000	0.001434	0.000756
7	0.000000	0.001526	0.000852
8	0.000000	0.001287	0.000923
9	0.000024	0.001445	0.001048
10	0.000024	0.001309	0.001360
11	0.000023	0.001333	0.001318
12	0.000050	0.001227	0.001391
13	0.000051	0.000865	0.001675
14	0.000057	0.000940	0.001757
15	0.000062	0.001180	0.001990
16	0.000104	0.001191	0.001987
17	0.000102	0.001038	0.002304
18	0.000251	0.001041	0.002454
19	0.000180	0.001089	0.002519
20	0.000192	0.000905	0.002240
21	0.000263	0.000719	0.002514
22	0.000306	0.000556	0.002991
23	0.000263	0.000699	0.002577

Test Cylinder No. 21, Flawed, +30° Wrap Angle, Position A
 Displacements: U1 at 0°, U1 at 80°, U2 at 40° (in.)

DATA NO.	U10(I)	U180(I)	U2(I)
1	0.001264	0.000880	0.000260
2	0.001164	0.000719	0.000260
3	0.001141	0.000935	0.000359
4	0.001151	0.000896	0.000394
5	0.001223	0.000817	0.000426
6	0.001092	0.000840	0.000484
7	0.000808	0.000904	0.000503
8	0.000971	0.000869	0.000542
9	0.000858	0.000826	0.000577
10	0.000888	0.000835	0.000621
11	0.000983	0.000864	0.000690
12	0.001122	0.000848	0.000738
13	0.001055	0.000735	0.000776
14	0.001028	0.000763	0.000765
15	0.000979	0.000791	0.000800
16	0.000938	0.000803	0.000893
17	0.001155	0.000874	0.000942
18	0.001140	0.000866	0.001003
19	0.000975	0.000943	0.001033
20	0.000987	0.001044	0.001061
21	0.000862	0.001121	0.001184
22	0.000891	0.000929	0.001242
23	0.000885	0.001022	0.001242

Test Cylinder No. 21, Flawed, +30° Wrap Angle, Position B
Displacements: U1 at 0°, U1 at 80°, U2 at 40° (in.)

DATA NO.	U10(I)	U180(I)	U2(I)
1	0.001103	0.000767	0.000358
2	0.001232	0.000752	0.000369
3	0.000979	0.000736	0.000369
4	0.000840	0.000752	0.000357
5	0.000904	0.000476	0.000429
6	0.000905	0.001072	0.000469
7	0.000824	0.001020	0.000502
8	0.000791	0.001034	0.000568
9	0.000760	0.000924	0.000610
10	0.000797	0.000895	0.000664
11	0.000948	0.000853	0.000704
12	0.000968	0.000849	0.000754
13	0.001052	0.000945	0.000799
14	0.001093	0.001022	0.000893
15	0.001026	0.000990	0.000933
16	0.000895	0.000953	0.000894
17	0.000978	0.001019	0.001006
18	0.000912	0.001059	0.001077
19	0.000886	0.000990	0.001111
20	0.000998	0.001095	0.001227
21	0.001077	0.001042	0.001272
22	0.000977	0.001025	0.001288
23	0.000838	0.000906	0.001354

Test Cylinder No. 21, Flawed, +30 Wrap Angle, Position C
Displacements: U1 at 0°, U1 at 80°, U2 at 40° (in.)

DATA NO.	U10(I)	U180(I)	U2(I)
1	0.001157	0.000919	0.000354
2	0.000906	0.001033	0.000354
3	0.001004	0.001080	0.000354
4	0.000911	0.001029	0.000354
5	0.000911	0.001027	0.000424
6	0.000905	0.001038	0.000478
7	0.000840	0.001050	0.000511
8	0.000834	0.001115	0.000556
9	0.000849	0.001097	0.000612
10	0.000825	0.001053	0.000682
11	0.000780	0.001054	0.000708
12	0.000754	0.001042	0.000760
13	0.000744	0.001027	0.000842
14	0.000755	0.000863	0.000848
15	0.000870	0.000889	0.000949
16	0.000930	0.000960	0.000992
17	0.000996	0.000787	0.001075
18	0.000968	0.000808	0.001064
19	0.000794	0.000859	0.001115
20	0.000739	0.001087	0.001182
21	0.000595	0.000990	0.001242
22	0.000452	0.001044	0.001260
23	0.000383	0.001025	0.001349

Test Cylinder No. 22, Flawed, +30° Wrap Angle, Position A
Displacements: U1 at 0°, U1 at 80°, U2 at 40° (in.)

DATA NO.	U10(I)	U180(I)	U2(I)
1	0.000777	0.001176	0.000320
2	0.000753	0.001134	0.000377
3	0.000709	0.001162	0.000391
4	0.000804	0.001139	0.000406
5	0.000845	0.001031	0.000440
6	0.000804	0.000962	0.000480
7	0.000779	0.000831	0.000528
8	0.000756	0.000924	0.000556
9	0.000809	0.000747	0.000541
10	0.000702	0.000707	0.000617
11	0.000772	0.000700	0.000678
12	0.000800	0.000826	0.000707
13	0.000734	0.000791	0.000756
14	0.000785	0.000800	0.000778
15	0.000715	0.000831	0.000813
16	0.000715	0.000746	0.000873
17	0.000739	0.000646	0.000871
18	0.000815	0.000818	0.000881
19	0.000916	0.000838	0.000959
20	0.000955	0.000776	0.001046
21	0.001039	0.000767	0.000996
22	0.001033	0.000743	0.001046
23	0.001066	0.000800	0.001070

Test Cylinder No. 22, Flawed, +30 Wrap Angle, Position B
Displacements: U1 at 0°, U1 at 80°, U2 at 40° (in.)

DATA NO.	U10(I)	U180(I)	U2(I)
1	0.001072	0.000808	0.000352
2	0.001188	0.000887	0.000406
3	0.000919	0.000818	0.000406
4	0.000742	0.000861	0.000406
5	0.000746	0.000932	0.000426
6	0.000787	0.000968	0.000431
7	0.000866	0.001023	0.000459
8	0.000861	0.000942	0.000540
9	0.000767	0.000887	0.000584
10	0.000832	0.000877	0.000614
11	0.000825	0.000747	0.000655
12	0.000797	0.000719	0.000708
13	0.000793	0.000721	0.000758
14	0.000679	0.000671	0.000796
15	0.000671	0.000691	0.000842
16	0.000693	0.000649	0.000885
17	0.000739	0.000605	0.000939
18	0.000782	0.000589	0.001002
19	0.000813	0.000574	0.001042
20	0.000865	0.000556	0.001052
21	0.000956	0.000509	0.001073
22	0.000990	0.000440	0.001107
23	0.001079	0.000423	0.001184

Test Cylinder No. 22, Flawed, +30° Wrap Angle, Position C
Displacements: U1 at 0°, U1 at 80°, U2 at 40° (in.)

DATA NO.	U10(I)	U180(I)	U2(I)
1	0.000698	0.001146	0.000352
2	0.000797	0.001118	0.000377
3	0.001006	0.001113	0.000391
4	0.000982	0.001045	0.000478
5	0.001038	0.001004	0.000526
6	0.001176	0.000915	0.000583
7	0.001286	0.000845	0.000635
8	0.001186	0.000809	0.000694
9	0.001283	0.000826	0.000794
10	0.001407	0.000849	0.000800
11	0.001279	0.001040	0.000837
12	0.001216	0.001063	0.000888
13	0.001188	0.001122	0.000911
14	0.001156	0.001009	0.000998
15	0.001136	0.000903	0.001059
16	0.001149	0.000832	0.001139
17	0.001200	0.000777	0.001178
18	0.001334	0.000725	0.001294
19	0.001334	0.000620	0.001310
20	0.001583	0.000622	0.001344
21	0.001539	0.000671	0.001459
22	0.001626	0.000747	0.001461
23	0.001467	0.000811	0.001503

Test Cylinder No. 23, Flawed, +30° Wrap Angle, Position A
Displacements: U1 at 0°, U1 at 80°, U2 at 40° (in.)

DATA NO.	U10(I)	U180(I)	U2(I)
1	0.000918	0.000716	0.000311
2	0.001035	0.000727	0.000320
3	0.000927	0.000700	0.000311
4	0.001014	0.000704	0.000311
5	0.000845	0.000676	0.000311
6	0.000982	0.000438	0.000320
7	0.001000	0.000761	0.000325
8	0.000816	0.000789	0.000330
9	0.000742	0.000777	0.000431
10	0.000669	0.000732	0.000449
11	0.000678	0.000783	0.000480
12	0.000761	0.000772	0.000533
13	0.000793	0.000803	0.000571
14	0.000836	0.000992	0.000621
15	0.000861	0.000826	0.000653
16	0.000919	0.000826	0.000693
17	0.000829	0.000669	0.000712
18	0.000862	0.000675	0.000797
19	0.000824	0.000666	0.000859
20	0.000669	0.000671	0.000936
21	0.000618	0.000777	0.001061
22	0.000539	0.000787	0.001030
23	0.000483	0.000868	0.001061

Test Cylinder No. 23, Flawed, +30° Wrap Angle, Position B
Displacements: U1 at 0°, U1 at 80°, U2 at 40° (in.)

DATA NO.	U10(I)	U180(I)	U2(I)
1	0.001291	0.000914	0.000306
2	0.001272	0.000876	0.000350
3	0.001260	0.000862	0.000358
4	0.001265	0.000768	0.000370
5	0.001025	0.000770	0.000364
6	0.000956	0.000809	0.000384
7	0.000989	0.000771	0.000414
8	0.000873	0.000775	0.000444
9	0.000989	0.000815	0.000469
10	0.001031	0.000787	0.000525
11	0.000803	0.000772	0.000571
12	0.000769	0.000794	0.000640
13	0.000765	0.000848	0.000680
14	0.000711	0.000899	0.000728
15	0.000735	0.000882	0.000713
16	0.000744	0.000738	0.000759
17	0.000671	0.000700	0.000844
18	0.000684	0.000707	0.000871
19	0.000587	0.000663	0.000916
20	0.000489	0.000748	0.001030
21	0.000489	0.000813	0.001050
22	0.000489	0.000942	0.001056
23	0.000489	0.001024	0.001127

Test Cylinder No. 23, Flawed, +30° Wrap Angle, Position C
Displacements: U1 at 0°, U1 at 80°, U2 at 40° (in.)

DATA NO.	U10(I)	U180(I)	U2(I)
1	0.000352	0.000873	0.000320
2	0.000352	0.001103	0.000406
3	0.001023	0.000930	0.000409
4	0.001122	0.000976	0.000436
5	0.000967	0.001194	0.000442
6	0.000814	0.001233	0.000461
7	0.000733	0.001055	0.000506
8	0.000727	0.001115	0.000558
9	0.000825	0.000984	0.000587
10	0.000829	0.000949	0.000640
11	0.000864	0.000917	0.000654
12	0.000797	0.000870	0.000712
13	0.000806	0.000895	0.000765
14	0.000845	0.000909	0.000829
15	0.000799	0.000962	0.000871
16	0.000637	0.001013	0.000898
17	0.000657	0.001287	0.000971
18	0.000663	0.001333	0.001043
19	0.000603	0.001334	0.001087
20	0.000701	0.001411	0.001161
21	0.000701	0.001497	0.001260
22	0.000701	0.001467	0.001307
23	0.000701	0.001528	0.001307

Test Cylinder No. 24, Flawed, +30° Wrap Angle, Position A
Displacements: U1 at 0°, U1 at 80°, U2 at 40° (in.)

DATA NO.	U10(I)	U180(I)	U2(I)
1	0.001272	0.001188	0.000352
2	0.001331	0.001210	0.000422
3	0.001323	0.001113	0.000459
4	0.001314	0.001180	0.000525
5	0.001157	0.001076	0.000587
6	0.001115	0.001018	0.000695
7	0.001146	0.001081	0.000704
8	0.001152	0.001037	0.000800
9	0.001139	0.000922	0.000810
10	0.001251	0.000878	0.000840
11	0.001207	0.001013	0.000877
12	0.001139	0.000996	0.000939
13	0.001121	0.000995	0.001030
14	0.001019	0.000970	0.001105
15	0.001095	0.001022	0.001173
16	0.000935	0.001032	0.001226
17	0.001001	0.001049	0.001281
18	0.001035	0.000923	0.001473
19	0.001182	0.001022	0.001479
20	0.001385	0.000732	0.001479
21	0.001414	0.000609	0.001547
22	0.001385	0.000526	0.001500
23	0.001354	0.000420	0.001596

Test Cylinder No. 24, Flawed, +30° Wrap Angle, Position B
Displacements: U1 at 0°, U1 at 80°, U2 at 40° (in.)

DATA NO.	U10(I)	U180(I)	U2(I)
1	0.001223	0.001175	0.000377
2	0.001180	0.001211	0.000406
3	0.001248	0.001291	0.000453
4	0.001188	0.000999	0.000526
5	0.001206	0.001115	0.000536
6	0.001126	0.000915	0.000598
7	0.001295	0.000679	0.000669
8	0.001293	0.000594	0.000712
9	0.001279	0.000636	0.000768
10	0.001331	0.000589	0.000857
11	0.001220	0.000600	0.000935
12	0.001263	0.000658	0.000954
13	0.001245	0.000785	0.000993
14	0.001172	0.000867	0.001033
15	0.001037	0.000942	0.001033
16	0.000998	0.000968	0.001101
17	0.001208	0.000846	0.001175
18	0.001187	0.000861	0.001278
19	0.001309	0.000763	0.001291
20	0.001550	0.000800	0.001391
21	0.001685	0.000708	0.001469
22	0.001626	0.000716	0.001512

Test Cylinder No. 24, Flawed, +30° Wrap Angle, Position C
Displacements: U1 at 0°, U1 at 80°, U2 at 40° (in.)

DATA NO.	U10(I)	U180(I)	U2(I)
1	0.001109	0.001236	0.000302
2	0.001215	0.001151	0.000377
3	0.001280	0.001291	0.000384
4	0.001306	0.001072	0.000449
5	0.001106	0.001063	0.000453
6	0.001266	0.000814	0.000575
7	0.001348	0.000642	0.000626
8	0.001272	0.000637	0.000666
9	0.001269	0.000644	0.000727
10	0.001280	0.000684	0.000783
11	0.001287	0.000625	0.000829
12	0.001475	0.000642	0.000901
13	0.001401	0.000654	0.000963
14	0.001280	0.000719	0.001050
15	0.001305	0.000747	0.001130
16	0.001266	0.000820	0.001168
17	0.001310	0.000866	0.001156
18	0.001330	0.000812	0.001268
19	0.001570	0.000749	0.001316
20	0.001502	0.000720	0.001444
21	0.001744	0.000693	0.001444
22	0.001931	0.000641	0.001529
23	0.002012	0.000959	0.001651

Test Cylinder No. 25, Unflawed, $+30^\circ$ Wrap Angle, Position A
Displacements: U1 at 0° , U1 at 80° , U2 at 40° (in.)

DATA NO.	U10(I)	U180(I)	U2(I)
1	0.001028	0.001258	0.000352
2	0.001023	0.001270	0.000391
3	0.000992	0.001291	0.000480
4	0.000981	0.001275	0.000523
5	0.001160	0.000990	0.000556
6	0.001207	0.000973	0.000559
7	0.001191	0.000864	0.000603
8	0.001110	0.000754	0.000660
9	0.001140	0.000700	0.000679
10	0.001090	0.000700	0.000723
11	0.001137	0.000739	0.000800
12	0.001101	0.000775	0.000855
13	0.001039	0.000905	0.000867
14	0.000976	0.000886	0.000945
15	0.001204	0.000893	0.001023
16	0.001207	0.000943	0.001033
17	0.001225	0.000916	0.001046
18	0.001245	0.000913	0.001101
19	0.001218	0.000871	0.001191
20	0.001467	0.000812	0.001278
21	0.001413	0.000775	0.001344
22	0.001493	0.000738	0.001398
23	0.001472	0.000772	0.001494
24	0.001508	0.000747	0.001538

Test Cylinder No. 25, Unflawed, +30° Wrap Angle, Position B
 Displacements: U1 at 0°, U1 at 80°, U2 at 40° (in.)

DATA NO.	U10(I)	U180(I)	U2(I)
1	0.001324	0.001250	0.000352
2	0.001264	0.001128	0.000377
3	0.001232	0.001079	0.000406
4	0.001218	0.001037	0.000463
5	0.001240	0.000924	0.000514
6	0.001191	0.000878	0.000569
7	0.001221	0.000841	0.000648
8	0.001384	0.000857	0.000685
9	0.001399	0.000882	0.000703
10	0.001407	0.000813	0.000806
11	0.001452	0.000772	0.000852
12	0.001298	0.000667	0.000929
13	0.001287	0.000690	0.000963
14	0.001356	0.000695	0.001030
15	0.001243	0.000693	0.001095
16	0.001226	0.000699	0.001130
17	0.001185	0.000668	0.001168
18	0.001178	0.000692	0.001268
19	0.001150	0.000657	0.001300
20	0.001556	0.000493	0.001316
21	0.001600	0.000406	0.001337
22	0.001765	0.000293	0.001415
23	0.001898	0.000276	0.001481
24	0.001710	0.000310	0.001524

Test Cylinder No. 25, Unflawed, +30° Wrap Angle, Position C
Displacements: U1 at 0°, U1 at 80°, U2 at 40° (in.)

DATA NO.	U10(I)	U180(I)	U2(I)
1	0.001037	0.001260	0.000377
2	0.000984	0.001232	0.000384
3	0.000945	0.001123	0.000409
4	0.000967	0.001016	0.000455
5	0.001092	0.000911	0.000491
6	0.001185	0.000917	0.000743
7	0.001341	0.000937	0.000612
8	0.001429	0.000946	0.000657
9	0.001398	0.000979	0.000727
10	0.001318	0.000954	0.000811
11	0.001191	0.000892	0.000844
12	0.001124	0.000926	0.000894
13	0.001189	0.001055	0.000917
14	0.001189	0.000996	0.001003
15	0.001207	0.000962	0.001033
16	0.001246	0.000943	0.001137
17	0.001246	0.000949	0.001107
18	0.001305	0.001000	0.001198
19	0.001245	0.000963	0.001287
20	0.001266	0.000932	0.001336
21	0.001385	0.000885	0.001407
22	0.001386	0.000763	0.001465
23	0.001413	0.000855	0.001507
24	0.001500	0.000872	0.001622

Test Cylinder No. 26, Unflawed, +30° Wrap Angle, Position A
Displacements: U1 at 0°, U1 at 80°, U2 at 40° (in.)

DATA NO.	U10(I)	U180(I)	U2(I)
1	0.001444	0.001223	0.000376
2	0.001264	0.001218	0.000414
3	0.001353	0.001160	0.000426
4	0.001297	0.001167	0.000469
5	0.001227	0.001129	0.000542
6	0.001276	0.001094	0.000614
7	0.001203	0.001081	0.000652
8	0.001201	0.001110	0.000714
9	0.001170	0.001109	0.000782
10	0.001189	0.001171	0.000866
11	0.001172	0.001079	0.000887
12	0.000998	0.000981	0.000918
13	0.001172	0.000728	0.000943
14	0.001190	0.000844	0.001035
15	0.001188	0.000799	0.001067
16	0.001151	0.000834	0.001112
17	0.001087	0.000861	0.001187
18	0.001066	0.000928	0.001257
19	0.000998	0.000984	0.001320
20	0.001122	0.000975	0.001408
21	0.001095	0.001046	0.001467
22	0.001089	0.001065	0.001530
23	0.001278	0.001015	0.001625

Test Cylinder No. 26, Unflawed, +30° Wrap Angle, Position B
Displacements: U1 at 0°, U1 at 80°, U2 at 40° (in.)

DATA NO.	U10(I)	U180(I)	U2(I)
1	0.001236	0.001098	0.000391
2	0.001314	0.001079	0.000406
3	0.001410	0.001148	0.000449
4	0.001426	0.001264	0.000480
5	0.001426	0.001323	0.000542
6	0.001387	0.001296	0.000640
7	0.001438	0.001276	0.000652
8	0.001288	0.001203	0.000714
9	0.001293	0.001167	0.000779
10	0.001110	0.001201	0.000742
11	0.000912	0.001222	0.000842
12	0.000943	0.001280	0.000884
13	0.001101	0.001303	0.000939
14	0.001154	0.001226	0.001002
15	0.001122	0.001151	0.001042
16	0.001119	0.001129	0.001109
17	0.001129	0.001162	0.001184
18	0.001164	0.001158	0.001239
19	0.001044	0.001155	0.001285
20	0.001049	0.001146	0.001405
21	0.001059	0.001556	0.001463
22	0.001001	0.001675	0.001463
23	0.001018	0.001849	0.001484

Test Cylinder No. 26, Unflawed, +30 Wrap Angle, Position C
Displacements: U1 at 0°, U1 at 80°, U2 at 40° (in.)

DATA NO.	U10(I)	U180(I)	U2(I)
1	0.001230	0.000845	0.000352
2	0.001260	0.000823	0.000377
3	0.001301	0.000810	0.000414
4	0.001225	0.000972	0.000453
5	0.001100	0.001023	0.000525
6	0.000825	0.001144	0.000580
7	0.000872	0.001369	0.000614
8	0.001042	0.001389	0.000681
9	0.001108	0.001325	0.000713
10	0.001171	0.001295	0.000744
11	0.001110	0.001181	0.000800
12	0.001189	0.001347	0.000845
13	0.001261	0.001395	0.000918
14	0.001285	0.001245	0.000960
15	0.001286	0.001285	0.001056
16	0.001189	0.001188	0.001112
17	0.001153	0.001246	0.001200
18	0.001169	0.001225	0.001354
19	0.001149	0.001243	0.001408
20	0.001007	0.001334	0.001427
21	0.001032	0.001411	0.001467
22	0.001042	0.001470	0.001509
23	0.001035	0.001477	0.001553

Test Cylinder No. 27, Unflawed, $+30^\circ$ Wrap Angle, Position A
Displacements: U1 at 0° , U1 at 80° , U2 at 40° (in.)

DATA NO.	U10(I)	U180(I)	U2(I)
1	0.001070	0.001691	0.000352
2	0.001016	0.001609	0.000364
3	0.000945	0.001672	0.000428
4	0.000962	0.001627	0.000484
5	0.000960	0.001517	0.000532
6	0.001147	0.001243	0.000590
7	0.001154	0.001109	0.000613
8	0.001106	0.000979	0.000646
9	0.000992	0.001231	0.000697
10	0.001013	0.001339	0.000763
11	0.000963	0.001407	0.000817
12	0.000913	0.001347	0.000865
13	0.000919	0.001390	0.000918
14	0.000926	0.001314	0.001005
15	0.000906	0.001280	0.001045
16	0.000894	0.001284	0.001067
17	0.000962	0.001225	0.001111
18	0.001207	0.001129	0.001186
19	0.001149	0.001185	0.001257
20	0.001143	0.001245	0.001288
21	0.001131	0.001218	0.001337
22	0.001300	0.001066	0.001427
23	0.001129	0.000913	0.001447
24	0.001211	0.000787	0.001530

Test Cylinder No. 27, Unflawed, $\pm 30^\circ$ Wrap Angle, Position B
Displacements: U1 at 0° , U1 at 80° , U2 at 40° (in.)

DATA NO.	U10(I)	U180(I)	U2(I)
1	0.001105	0.001299	0.000352
2	0.001091	0.001200	0.000424
3	0.001095	0.001288	0.000465
4	0.001064	0.001148	0.000521
5	0.001105	0.001244	0.000564
6	0.001120	0.001257	0.000615
7	0.000994	0.001345	0.000676
8	0.001006	0.001452	0.000724
9	0.001068	0.001156	0.000778
10	0.001081	0.001044	0.000844
11	0.001053	0.001024	0.000879
12	0.001156	0.000998	0.000918
13	0.001189	0.000963	0.001056
14	0.001298	0.000998	0.001067
15	0.001280	0.001108	0.001148
16	0.001226	0.001055	0.001200
17	0.000978	0.001001	0.001272
18	0.000885	0.000923	0.001320
19	0.000984	0.000763	0.001408
20	0.001049	0.000735	0.001467
21	0.001104	0.000716	0.001509
22	0.001183	0.000399	0.001625
23	0.001245	0.000493	0.001703

Test Cylinder No. 27, Unflawed, +30° Wrap Angle, Position C
Displacements: U1 at 0°, U1 at 80°, U2 at 40° (in.)

DATA NO.	U10(I)	U180(I)	U2(I)
1	0.001050	0.001134	0.000376
2	0.001092	0.001115	0.000405
3	0.001090	0.001126	0.000447
4	0.000990	0.001126	0.000498
5	0.000871	0.001191	0.000549
6	0.000838	0.001243	0.000594
7	0.000706	0.001270	0.000635
8	0.000714	0.001068	0.000715
9	0.000995	0.001024	0.000773
10	0.001006	0.000972	0.000826
11	0.000974	0.000969	0.000875
12	0.000957	0.001046	0.000926
13	0.001009	0.001075	0.000984
14	0.000956	0.001052	0.001033
15	0.000956	0.001079	0.001095
16	0.001025	0.001162	0.001182
17	0.001178	0.001100	0.001278
18	0.001182	0.000978	0.001299
19	0.001146	0.001001	0.001403
20	0.001250	0.001101	0.001443
21	0.001271	0.001307	0.001463
22	0.001267	0.001332	0.001528
23	0.001205	0.001181	0.001624

Test Cylinder No. 28, Unflawed, +30° Wrap Angle, Position A
Displacements: U1 at 0°, U1 at 80°, U2 at 40° (in.)

DATA NO.	U10(I)	U180(I)	U2(I)
1	0.001272	0.001107	0.000351
2	0.001194	0.001007	0.000390
3	0.001088	0.001032	0.000421
4	0.001176	0.001025	0.000468
5	0.001266	0.001006	0.000502
6	0.001227	0.001042	0.000569
7	0.001219	0.001018	0.000650
8	0.001207	0.000895	0.000680
9	0.001095	0.000906	0.000742
10	0.001063	0.000978	0.000856
11	0.000948	0.001030	0.000843
12	0.000996	0.001019	0.000885
13	0.000978	0.000995	0.000956
14	0.000817	0.001009	0.001002
15	0.000704	0.001004	0.001040
16	0.000908	0.001044	0.001103
17	0.000853	0.000921	0.001139
18	0.000891	0.001025	0.001233
19	0.000858	0.000909	0.001278
20	0.000897	0.000985	0.001307
21	0.000959	0.000928	0.001376
22	0.000984	0.000866	0.001452
23	0.001046	0.000906	0.001497

Test Cylinder No. 28, Unflawed, $\pm 30^\circ$ Wrap Angle, Position B
Displacements: U1 at 0° , U1 at 80° , U2 at 40° (in.)

DATA NO.	U10(I)	U180(I)	U2(I)
1	0.001020	0.001238	0.000351
2	0.001030	0.001174	0.000390
3	0.000971	0.001202	0.000405
4	0.001109	0.001064	0.000439
5	0.001167	0.000924	0.000514
6	0.001209	0.000963	0.000569
7	0.001296	0.000923	0.000612
8	0.001286	0.000917	0.000638
9	0.001295	0.000909	0.000727
10	0.001279	0.001110	0.000775
11	0.001187	0.001261	0.000823
12	0.001263	0.001073	0.000871
13	0.001139	0.001085	0.000941
14	0.001222	0.001169	0.000975
15	0.001189	0.001111	0.001133
16	0.001226	0.001100	0.001170
17	0.001266	0.001072	0.001239
18	0.001245	0.001287	0.001317
19	0.001221	0.001359	0.001333
20	0.001285	0.001212	0.001463
21	0.001386	0.001102	0.001463
22	0.001356	0.001171	0.001596
23	0.001445	0.001136	0.001672

Test Cylinder No. 28, Unflawed, +30° Wrap Angle, Position C
Displacements: U1 at 0°, U1 at 80°, U2 at 40° (in.)

DATA NO.	U10(I)	U180(I)	U2(I)
1	0.001238	0.001300	0.000352
2	0.001229	0.001220	0.000377
3	0.001210	0.001275	0.000422
4	0.001180	0.001346	0.000446
5	0.001182	0.001240	0.000501
6	0.001201	0.001323	0.000569
7	0.001165	0.001314	0.000602
8	0.001068	0.001092	0.000651
9	0.001172	0.000961	0.000680
10	0.001172	0.000889	0.000764
11	0.001156	0.000923	0.000800
12	0.000996	0.000962	0.000845
13	0.001048	0.001005	0.000880
14	0.001000	0.001037	0.000960
15	0.000976	0.001052	0.001035
16	0.000886	0.001156	0.001025
17	0.000929	0.001324	0.001111
18	0.000963	0.001266	0.001160
19	0.001001	0.001266	0.001186
20	0.001009	0.001226	0.001288
21	0.001129	0.001200	0.001408
22	0.001359	0.001200	0.001427
23	0.001545	0.001221	0.001466

Test Cylinder No. 29, Unflawed, +30° Wrap Angle, Position A
Displacements: U1 at 0°, U1 at 80°, U2 at 40° (in.)

DATA NO.	U10(I)	U180(I)	U2(I)
1	0.000663	0.001486	0.000435
2	0.000703	0.001618	0.000455
3	0.000626	0.001885	0.000474
4	0.000622	0.001772	0.000561
5	0.000726	0.001531	0.000636
6	0.000679	0.001530	0.000679
7	0.000658	0.001620	0.000728
8	0.000636	0.001754	0.000773
9	0.000669	0.001709	0.000851
10	0.000715	0.001711	0.000897
11	0.000705	0.001245	0.000953
12	0.000677	0.001321	0.001043
13	0.000660	0.001493	0.001280
14	0.000636	0.001741	0.001130
15	0.000683	0.001829	0.001156
16	0.000661	0.001905	0.001182
17	0.000643	0.001988	0.001223
18	0.000620	0.002057	0.001268
19	0.000629	0.001990	0.001333
20	0.000573	0.001757	0.001469
21	0.000720	0.001798	0.001456
22	0.000687	0.001635	0.001591
23	0.000773	0.001550	0.001694
24	0.000799	0.001726	0.001725

Test Cylinder No. 29, Unflawed, +30° Wrap Angle, Position B
Displacements: U1 at 0°, U1 at 80°, U2 at 40° (in.)

DATA NO.	U10(I)	U180(I)	U2(I)
1	0.001118	0.001143	0.000421
2	0.001331	0.001025	0.000439
3	0.001249	0.001023	0.000495
4	0.001184	0.001076	0.000453
5	0.001121	0.001106	0.000624
6	0.001181	0.001109	0.000699
7	0.001153	0.001064	0.000738
8	0.001185	0.001108	0.000776
9	0.001171	0.001090	0.000839
10	0.001207	0.001088	0.000936
11	0.001190	0.001136	0.000953
12	0.001297	0.001187	0.001028
13	0.000903	0.001108	0.001048
14	0.000929	0.001140	0.001103
15	0.000887	0.001113	0.001139
16	0.000932	0.001182	0.001178
17	0.000848	0.001121	0.001278
18	0.001017	0.001155	0.001294
19	0.001150	0.001129	0.001310
20	0.001150	0.001436	0.001329
21	0.001017	0.001035	0.001400
22	0.001119	0.000933	0.001461
23	0.001166	0.000826	0.001503
24	0.001166	0.000827	0.001618

Test Cylinder No. 29, Unflawed, $+30^\circ$ Wrap Angle, Position C
Displacements: U1 at 0° , U1 at 80° , U2 at 40° (in.)

DATA NO.	U10(I)	U180(I)	U2(I)
1	0.001233	0.001083	0.000349
2	0.001444	0.001220	0.000373
3	0.000778	0.001134	0.000377
4	0.000784	0.001053	0.000391
5	0.000825	0.000972	0.000431
6	0.000896	0.001023	0.000490
7	0.000951	0.000915	0.000430
8	0.000963	0.000824	0.000468
9	0.001018	0.000917	0.000650
10	0.000899	0.000919	0.000723
11	0.000917	0.000957	0.000776
12	0.000925	0.001030	0.000829
13	0.000889	0.001207	0.000904
14	0.000849	0.001226	0.000987
15	0.000894	0.001225	0.000997
16	0.001013	0.001203	0.001047
17	0.000983	0.001158	0.001106
18	0.001037	0.001158	0.001156
19	0.001044	0.001113	0.001223
20	0.000985	0.001170	0.001253
21	0.000993	0.001208	0.001268
22	0.001009	0.001182	0.001307
23	0.001074	0.001046	0.001452
24	0.001181	0.000931	0.001538

Test Cylinder No. 30, Unflawed, +30° Wrap Angle, Position A
Displacements: U1 at 0°, U1 at 80, U2 at 40° (in.)

DATA NO.	U10(I)	U180(I)	U2(I)
1	0.001174	0.001278	0.000352
2	0.001220	0.001275	0.000376
3	0.001167	0.001167	0.000439
4	0.001138	0.001180	0.000468
5	0.001126	0.001209	0.000527
6	0.001102	0.001097	0.000601
7	0.001004	0.000952	0.000638
8	0.001106	0.000902	0.000688
9	0.001081	0.000923	0.000763
10	0.001080	0.000965	0.000800
11	0.001124	0.000845	0.000838
12	0.001156	0.000888	0.000918
13	0.001105	0.000893	0.001006
14	0.001103	0.000891	0.001035
15	0.000862	0.000874	0.001148
16	0.000777	0.000844	0.001160
17	0.000800	0.000834	0.001288
18	0.000863	0.000733	0.001242
19	0.000852	0.000812	0.001288
20	0.000933	0.000811	0.001337
21	0.000989	0.000708	0.001408
22	0.000989	0.000661	0.001427
23	0.000943	0.000396	0.001509
24	0.000910	0.000338	0.001466

Test Cylinder No. 30, Unflawed, +30° Wrap Angle, Position B
Displacements: U1 at 0°, U1 at 80°, U2 at 40° (in.)

DATA NO.	U10(I)	U180(I)	U2(I)
1	0.001000	0.001398	0.000377
2	0.000763	0.001387	0.000391
3	0.000760	0.001410	0.000422
4	0.000742	0.001415	0.000449
5	0.000751	0.001426	0.000497
6	0.000893	0.001286	0.000581
7	0.001065	0.001259	0.000608
8	0.001131	0.001126	0.000656
9	0.001194	0.001106	0.000726
10	0.001122	0.001181	0.000763
11	0.001081	0.001183	0.000797
12	0.001040	0.001171	0.000842
13	0.001094	0.001172	0.000892
14	0.001073	0.001284	0.001002
15	0.001117	0.001285	0.001043
16	0.001167	0.001266	0.001107
17	0.001164	0.001246	0.001143
18	0.001266	0.001225	0.001195
19	0.001245	0.001162	0.001286
20	0.001245	0.001140	0.001319
21	0.001178	0.001136	0.001408
22	0.001131	0.001025	0.001427
23	0.001234	0.000948	0.001467
24	0.001208	0.001015	0.001487

Test Cylinder No. 30, Unflawed, $+30^\circ$ Wrap Angle, Position C
Displacements: U1 at 0° , U1 at 80° , U2 at 40° (in.)

DATA NO.	U10(I)	U180(I)	U2(I)
1	0.001098	0.001452	0.000352
2	0.001092	0.001481	0.000377
3	0.001103	0.001415	0.000406
4	0.001100	0.001385	0.000490
5	0.001049	0.001450	0.000540
6	0.001097	0.001323	0.000579
7	0.000995	0.001246	0.000680
8	0.001006	0.001054	0.000686
9	0.001042	0.000948	0.000713
10	0.001095	0.000707	0.000798
11	0.001110	0.000730	0.000843
12	0.001124	0.000763	0.000890
13	0.001104	0.000912	0.000934
14	0.001090	0.000983	0.001025
15	0.001105	0.000886	0.001056
16	0.001149	0.000883	0.001056
17	0.001164	0.000874	0.001137
18	0.001122	0.000857	0.001188
19	0.001095	0.000800	0.001245
20	0.001218	0.000800	0.001316
21	0.001440	0.000772	0.001507
22	0.001440	0.000732	0.001465
23	0.001440	0.000781	0.001507
24	0.001440	0.000750	0.001600

Appendix B. COMPUTER CODES*

* The computer codes were written in Fortran IV language to be used with a PDP 11/40 computer.

PROGRAM 1

Program Name: SPEC.FOR (written by J. A. Schaeffel, Jr.)

Purpose: Analyze interferograms on a point by point basis computing circumferential and axial displacements and advancing X-Y translation table.

Input:

- 1) Stage to be advanced — either X-direction or Y-direction.
- 2) Stage increment — distance translation table moves.
- 3) Film scale factor — ratio of real object to image on interferogram.
- 4) Displacement — distance between fringes.
- 5) Angle — angle of orientation of fringes.

Output: Data are printed on a decwriter.

```

1) =DUAL:SPEC FOR
COMMON DD(2,200)
WRITE(5,1)
1  FORMAT(' MANUAL YOUNG FRINGE ANALYZER ')
  WRITE(5,2)
2  FORMAT(' STAGE TO BE ADVANCED? (0=X,1=Y) ')
  READ(5,3) IA
3  FORMAT(I1)
  WRITE(5,4)
4  FORMAT(' STAGE INCREMENT? ')
  READ(5,5) IC
5  FORMAT(I4)
  WRITE(5,6)
6  FORMAT(' FILM SCALE FACTOR? ')
  READ(5,7) SF
7  FORMAT(F10.0)
  ICC=0
8  ICC=ICC+1
  ICP=ICC-1
  WRITE(5,9)
9  FORMAT(' DISPLACEMENT? ')
  READ(5,7) D
  WRITE(5,10)
10 FORMAT(' ANGLE? ')
  READ(5,7) A
  A=A*3.14159/180.
  IF(D.EQ.0) GOTO 13
  IF(D.LT.0) GOTO 15
  U=SF/D
  U1=U*COS(A)
  U2=U*SIN(A)
  H=FLOAT((ICC-1)*IC)*.001
  WRITE(5,11) H,U,U1,U2
11  FORMAT(3H H=,F10.3,5X,2HU=,F12.,
13HU1=,F12.6,5X,3HU2=,F12.6)
12  DD(1,ICC)=U1
  DD(2,ICC)=U2
  GOTO 14
13  DD(1,ICC)=0.
  DD(2,ICC)=0.
14  IF(IA.EQ.1) CALL YADV(IC,5)
  IF(IA.EQ.0) CALL XADV(IC,5)
  GOTO 8
15  ICC=(1-ICC)*IC
  IF(IA.EQ.1) CALL YADV(ICC,5)
  IF(IA.EQ.0) CALL XADV(ICC,5)
  CALL PLOT(ICP,1)
  CALL PLOT(ICP,2)
  WRITE(5,16)

```

```

16  FORMAT(' ANALYSIS ENDED')
    STOP
    END
    SUBROUTINE PLOT(ICP,K)
    COMMON DD(2,200)
    S1=DD(K,1)
    DO 1 I=2,ICP,1
1   IF(DD(K,I).GT.S1) S1=DD(K,I)
    IF(S1.EQ.0) S1=1.
2   CALL IPOKE('170410','1')
    CALL IPOKE('170410','0')
    DO 3 I=1,ICP,1
    J=INT(DD(K,I)*1000./S1)
    CALL IPOKE('170412,J)
3   CALL IPOKE('170412','0')
    ITEST=IPEEK('177570')
    IF(ITEST.EQ.0) GOTO 2
4   ITEST=IPEEK('177570')
    IF(ITEST.NE.0) GOTO 4
    RETURN
    END
    SUBROUTINE YADV(IS,IR)
C-----IS=NO. STEPS (+=FWD, -=REV)
C-----IR=ADVANCE RATE OF STAGE
    X=0.
    IF(IS.GT.0) GOTO 3
    IP=IABS(IS)
    DO 2 I=1,IP,1
    CALL IPOKE('167772','020000)
    DO 7 K=1,IR,1
7   Y=SIN(X)
    CALL IPOKE('167772','000000)
    DO 1 J=1,IR,1
1   Y=SIN(X)
2   CONTINUE
    GOTO 6
3   CONTINUE
    DO 5 II=1,IS,1
    CALL IPOKE('167772','010000)
    DO 8 KK=1,IR,1
8   Y=SIN(X)
    CALL IPOKE('167772','000000)
    DO 4 JJ=1,IR,1
4   Y=SIN(X)
5   CONTINUE

```

```

6      CONTINUE
      RETURN
      END
      SUBROUTINE XADV(IS,IR)
C-----IS=NO. STEPS (+=FWD, -=REV)
C-----IR=ADVANCE RATE OF STAGE
      X=0.
      IF(IS.GT.0) GOTO 3
      IF=IABS(IS)
      DO 2 I=1,IF,1
      CALL IPOKE('167772','100000')
      DO 7 K=1,IR,1
7      Y=SIN(X)
      CALL IPOKE('167772','000000')
      DO 1 J=1,IR,1
1      Y=SIN(X)
2      CONTINUE
      GOTO 6
3      CONTINUE
      DO 5 II=1,IS,1
      CALL IPOKE('167772','040000')
      DO 8 KK=1,IR,1
8      Y=SIN(X)
      CALL IPOKE('167772','000000')
      DO 4 JJ=1,IR,1
4      Y=SIN(X)
5      CONTINUE
6      CONTINUE
      RETURN
      END
*
```

PROGRAM 2

Program Name: MODULE.FOR (written by Terry L. Vandiver)

Purpose: To calculate the circumferential stress, circumferential strain, axial strain, composite modulus of elasticity, Poisson's ratio.

Input:

- 1) Number data points — total number of data points to be entered.
- 2) Film scale factor — ratio of real object to object image on interferogram.
- 3) Pressure, mean radius, outside radius, thickness — parameters of the test cylinders.
- 4) U1 at 0° — Circumferential displacement from the 0°-scan line.
- 5) U1 at 80° — Circumferential displacement for the 80°-scan line.
- 6) U2 at 40° — Axial displacement for the 40°-scan line.

Output: Data are written on a decwriter.

```

TT:=DX1:MODULE.FOR
REAL MODULS
DIMENSION U10(50),U180(50),U2(50),X(50)
WRITE(5,10)
10  FORMAT(' NUMBER OF DATA POINTS?')
    READ(5,20) N
20  FORMAT(I3)
    WRITE(5,25)
25  FORMAT(' FILM SCALE FACTOR?')
    READ(5,30) FILMSF
30  FORMAT(F10.0)
    WRITE(5,40)
40  FORMAT(' INPUT PRESSURE, MEAN RADIUS, OUTSIDE RADIUS
1 AND THICKNESS: 4F6.0')
    READ(5,50) PRESS,RADUSM,ORADUS,THICK
50  FORMAT(4F6.0)
    WRITE(5,60)
60  FORMAT(' INPUT U10-AT 0 DEGREES')
    DO 65 I=1,N
    READ(5,30) U10(I)
65  CONTINUE
    WRITE(5,70)
70  FORMAT(' INPUT U180-AT 80 DEGREES')
    DO 75 I=1,N
    READ(5,30) U180(I)
75  CONTINUE
    WRITE(5,80)
80  FORMAT(' INPUT U2-AT 40 DEGREES')
    DO 85 I=1,N
    READ(5,30) U2(I)
95  CONTINUE
    SUMU10=0.
    SUMU18=0.
    SUMXU2=0.
    SUMX=0.
    SUMU2=0.
    SUMXSQ=0.
    WRITE(5,90)
90  FORMAT(4X,'DATA NO.',5X,'U10(I)',7X,'U180(I)',6X,'U2(I)')
    DO 110 I=1,N
    X(I)=FILMSF*FLOAT(I-1)
    SUMU10=SUMU10+U10(I)
    SUMU18=SUMU18+U180(I)
    SUMXU2=SUMXU2+X(I)*U2(I)
    SUMX=SUMX+X(I)
    SUMU2=SUMU2+U2(I)
    SUMXSQ=SUMXSQ+X(I)*X(I)
    WRITE(5,100) I,U10(I),U180(I),U2(I)
100  FORMAT(6X,I3,5X,F8.0,5X,F8.0,5X,F8.5)

```

```

110  CONTINUE
      CSTRES=PRESS*RADUSM/THICK
      WRITE(5,120) CSTRES
120  FORMAT(' CIRCUMFERENTIAL STRESS= ',F10.4)
      U1=(SUMU10+SUMU18)/(2.*FLOAT(N))
      R=U1/.6427876
      CSTRAN=R/ORADUS
      MODULS=CSTRES/CSTRAN
      ASTRAN=((SUMXU2)*FLOAT(N)-(SUMX)*(SUMU2))/((SUMX50)*FLOAT(N)-
1      1(SUMX)*(SUMX))
      POISON=ASTRAN/CSTRAN
      WRITE(5,130) ASTRAN
      WRITE(5,140) CSTRAN
      WRITE(5,150) POISON
      WRITE(5,160) MODULS
.30  FORMAT(' AXIAL STRAIN= ',F11.8)
.40  FORMAT(' CIRCUMFERENTIAL STRAIN= ',F11.8)
.50  FORMAT(' POISSONS RATIO= ',F10.4)
.60  FORMAT(' COMPOSITE MODULUS OF ELASTICITY= ',E11.4)
      STOP
      END

```

PROGRAM 3

Program Name: STAT.FOR (written by Terry L. Vandiver)

Purpose: To calculate means and standard deviations for elasticity constants.

Input:

- 1) **Data Points** — total number of data points to be entered.
- 2) **Modulus of Elasticity and Poisson's ratio** — selected values obtained from Program 2.

Output: Data are written on a decwriter.

*TT:=DX1:STAT.FOR

```
      DIMENSION E(100),U(100)
      WRITE(5,10)
10     FORMAT(' NUMBER OF DATA POINTS?')
      READ(5,20)N
20     FORMAT(I3)
      WRITE(5,30)
30     FORMAT(' INPUT MODULUS OF ELASTICITY AND POISSONS RATIO: 2F10.0')
      DO 45 I=1,N
      READ(5,40) E(I),U(I)
40     FORMAT(2F10.0)
45     CONTINUE
      SUME=0.0
      SUMU=0.0
      SUMAE=0.0
      SUMBU=0.0
      WRITE(5,50)
50     FORMAT(4X,'DATA NO.',5X,'MODULUS(I)',6X,'POISSONS RATIO(I)')
      DO 70 I=1,N
      SUME=SUME+E(I)
      SUMU=SUMU+U(I)
      WRITE(5,60)I,E(I),U(I)
60     FORMAT(6X,I3,9X,E11.4,5X,F10.4)
70     CONTINUE
      EM=SUME/FLOAT(N)
      UM=SUMU/FLOAT(N)
      DO 75 I=1,N
      SUMAE=SUMAE+(E(I)-EM)*(E(I)-EM)
      SUMBU=SUMBU+(U(I)-UM)*(U(I)-UM)
75     CONTINUE
      WRITE(5,80)EM
80     FORMAT(' MODULUS OF ELASTICITY MEAN= ',E11.4)
      WRITE(5,90)UM
90     FORMAT(' POISSONS RATIO MEAN= ',F10.4)
      EMSD=SQRT((SUMAE)/FLOAT(N-1))
      UMSD=SQRT((SUMBU)/FLOAT(N-1))
      WRITE(5,100)EMSD
100    FORMAT(' MODULUS OF ELASTICITY STANDARD DEVIATION= ',E12.4)
      WRITE(5,110)UMSD
110    FORMAT(' POISSONS RATIO STANDARD DEVIATION= ',F10.4)
      STOP
      END
```

*

DISTRIBUTION

	No. of Copies		No. of Copies
Defense Metals Information Center Battelle Memorial Institute 505 King Avenue Columbus, Ohio 43201	1	Commander Wright Air Development Division Attn: ASBC Wright-Patterson AFB, Ohio 45433	1
Defense Documentation Center Common Station Alexandria, Virginia 22314	12	Director Air Force Materiel Laboratory Attn: AFML-DO-Library Wright-Patterson AFB, Ohio 45433	1
Commander US Army Foreign Science and Technology Center Attn: DEXST-SD3 220 Seventh Street, NE Charlottesville, Virginia 22901	1	Director, Army Materials and Mechanics Research Center Attn: DREMS-FL DREMS-MT, M. Farrow Watertown, Massachusetts 02172	1 1
Office of Chief of Research and Development Department of the Army Attn: DAND-ARM-P Washington, D.C. 20301	1	Jet Propulsion Laboratory California Institute of Technology Attn: Library/Acquisitions 111-113 4800 Oak Grove Drive Pasadena, California 91103	1
Commander US Army Natick Laboratories Kennebec Street Attn: STNLT-NQR Natick, Massachusetts 01760	1	Sandia Laboratories Attn: Library P.O. Box 969 Livermore, California 94550	1
Commander US Army Mobility Equipment Research and Development Center Fort Belvoir, Virginia 22060	1	Technical Library Naval Ordnance Station Indian Head, Maryland 20640	1
Director USA Mobility Equipment Research and Development Center Coating and Chemical Laboratory Attn: STSFB-CL Aberdeen Proving Ground, Maryland 21005	1	Commander US Army Materiel Development and Readiness Command Attn: DRCMD DRCMD 5001 Eisenhower Avenue Alexandria, Virginia 22333	1 1
Commander Edgewood Arsenal Attn: SARPA-TS-A Aberdeen Proving Ground, Maryland 21010	1	Commander US Army Materiel Development and Readiness Command Attn: DRCMD Washington, D.C. 20315	1
Commander Picatinny Arsenal Attn: SARPA-TS-S, Mr. M. Costello Dover, New Jersey 07801	1	Headquarters SAC/RLI (Stinfo Library) Offutt Air Force Base, Nebraska 68113	1
Commander Watervliet Arsenal Watervliet, New York 12189	1	Department of the Army US Army Research Office Attn: Information Processing Office P.O. Box 12211 Research Triangle Park, North Carolina 27709	1
Commander US Army Aviation Systems Command Attn: DREAV-EE DREAV-EE, Mr. Vollmer St. Louis, Missouri 63166	1 1	ADTC (DLDEL) Eglin Air Force Base, Florida 32542	1
Commander US Army Aeronautical Depot Maintenance Center (Mail Stop) Corpus Christi, Texas 78403	1	University of California Los Alamos Scientific Laboratory Attn: Reports Library P.O. Box 1663 Los Alamos, New Mexico 87545	1
Commander US Army Test and Evaluation Command Attn: DRESTE-BA Aberdeen Proving Ground, Maryland 21005	1	Library US Army War College Carlisle Barracks, Pennsylvania 17013	1
Commander US Army White Sands Missile Range Attn: STWR-AD-L White Sands Missile Range, New Mexico 88002	1	Commander US Army Research Office Attn: DREMO-FH, Dr. R. Lantz P.O. Box 12211 Research Triangle Park, North Carolina 27709	2
Commander Attn: STRAP-MT Aberdeen Proving Ground, Maryland 21005	1	US Army Research and Standardization Group (Europe) Attn: DRESE-E-ER, Dr. Alfred K. Nedoluha Box 65 FPO New York 09510	2
Naval Research Laboratory Attn: Dr. M. M. Krafft Code 8430 Washington, D.C. 20375	1	US Army Materiel Development and Readiness Command Attn: Mr. Edward Sedlak 5001 Eisenhower Avenue Alexandria, Virginia 22333	1

DISTRIBUTION

	No. of Copies
Headquarters Department of the Army Office of the Deputy Chief of Staff for Research Development and Acquisition Actn: DASA-ASR Room 3A474, the Pentagon Washington, D.C. 20310	2
Director Defense Advanced Research Projects Agency 1400 Wilson Boulevard Arlington, Virginia 22209	1
US Army Materiel Systems Analysis Activity Actn: DMSA-MS Aberdeen Proving Ground, MD 21005	1
DMSA-IP, Mr. Voigt	1
DMSA-E, Mr. McKinley	1
-T, Dr. Kohler	1
-TL, Mr. Lewis	1
-TIA, Mr. Fetty	1
Mr. Vandiver	30
-EA	2
-EAA	2
-EAB	1
-EAC	1
-EAM	1
-EAP	1
-EAT	1
-E	1
-ICSB	1
-SFR	1
-TSD	3
-TI (Record Set)	1
-TI (Reference Copy)	1