

AD-A069 202

ARMY AEROMEDICAL RESEARCH LAB FORT RUCKER AL
A PORCINE BIOASSAY METHOD FOR ANALYSIS OF THERMALLY PROTECTIVE --ETC(U)
JUN 78 T L WACHTEL, F S KNOX, G R MCCAHAN
USAARL-78-8

F/G 6/3

UNCLASSIFIED

NL

| OF |
AD
A069202



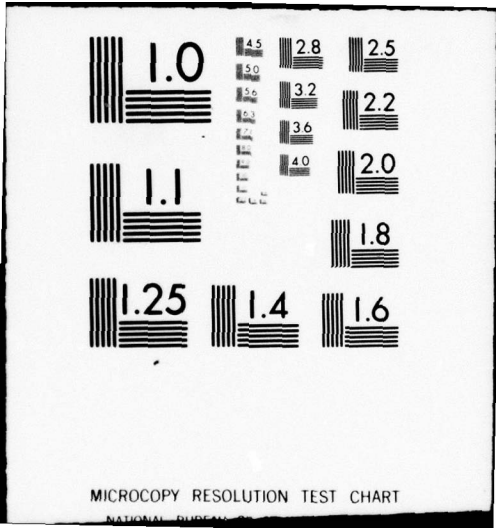

MICROCOPY RESOLUTION TEST CHART

NATIONAL BUREAU OF STANDARDS-1963-A

ADA069202

DDC FILE COPY



R
NW
LEVEL II

USAARL REPORT NO. 78-8

**A PORCINE BIOASSAY METHOD FOR ANALYSIS
OF THERMALLY PROTECTIVE FABRICS:
A CLINICAL GRADING SYSTEM**

By

Thomas L. Wachtel
Francis S. Knox, III
G. R. McCahan, Jr.

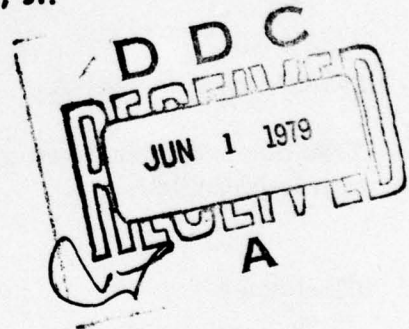

June 1978

U.S. ARMY AEROMEDICAL RESEARCH LABORATORY
FORT RUCKER, ALABAMA 36362

79 05 29 121

USAARL

NOTICE

Qualified requesters may obtain copies from the Defense Documentation Center (DDC), Cameron Station, Alexandria, Virginia. Orders will be expedited if placed through the librarian or other person designated to request documents from DDC.

Change of Address

Organizations receiving reports from the U. S. Army Aeromedical Research Laboratory on automatic mailing lists should confirm correct address when corresponding about laboratory reports.

Disposition

Destroy this report when it is no longer needed. Do not return it to the originator.

Distribution Statement

This document has been approved for public release and sale; its distribution is unlimited.

Disclaimer

The findings in this report are not to be construed as an official Department of the Army position unless so designated by other authorized documents.

UNCLASSIFIED

SECURITY CLASSIFICATION OF THIS PAGE (When Data Entered)

REPORT DOCUMENTATION PAGE		READ INSTRUCTIONS BEFORE COMPLETING FORM
1. REPORT NUMBER 14 USAARL Report No -78-8	2. GOVT ACCESSION NO.	3. RECIPIENT'S CATALOG NUMBER
4. TITLE (and Subtitle) 6 A PORCINE BIOASSAY METHOD FOR ANALYSIS OF THERMALLY PROTECTIVE FABRICS: A CLINICAL GRADING SYSTEM,	5. TYPE OF REPORT & PERIOD COVERED 7 Final Report	
7. AUTHOR(s) 10 T. L. Wachtel, F. S. Knox, III, and G. R. McCahan, Jr.	6. PERFORMING ORG. REPORT NUMBER	
9. PERFORMING ORGANIZATION NAME AND ADDRESS US Army Aeromedical Research Laboratory P. O. Box 577 Fort Rucker, AL 36362	8. CONTRACT OR GRANT NUMBER(s)	
11. CONTROLLING OFFICE NAME AND ADDRESS US Army Medical Research & Development Command Fort Detrick Frederick, MD 21701	10. PROGRAM ELEMENT, PROJECT, TASK AREA & WORK UNIT NUMBERS 16 6.27.73.A 3E762173A819 015	12. REPORT DATE June 1978
14. MONITORING AGENCY NAME & ADDRESS (if different from Controlling Office) 12 35p.	13. NUMBER OF PAGES 26	15. SECURITY CLASS. (of this report) Unclassified
16. DISTRIBUTION STATEMENT (of this Report) This document has been approved for public release and sale; its distribution is unlimited.		
17. DISTRIBUTION STATEMENT (of the abstract entered in Block 20, if different from Report)		
18. SUPPLEMENTARY NOTES		
19. KEY WORDS (Continue on reverse side if necessary and identify by block number) Burns Bioassay Test Methods Porcine Skin Aviation Safety		
20. ABSTRACT (Continue on reverse side if necessary and identify by block number) A clinical grading system of severity of cutaneous burn was developed in a porcine cutaneous burn bioassay model using a flame thermal source. From surface appearance, color, sensation, tactile response, tenacity of hair anchoring, and appearance on cut section, a progression of the severity of burn injury was developed and documented with serial still photographs, high-speed cinemotomography and clinical descriptions. Variations in this grading scheme were required for skin		

DD FORM 1473 EDITION OF 1 NOV 65 IS OBSOLETE

UNCLASSIFIED

SECURITY CLASSIFICATION OF THIS PAGE (When Data Entered)

404 578

13

UNCLASSIFIED

SECURITY CLASSIFICATION OF THIS PAGE(When Data Entered)

20. ABSTRACT (Con't)

protected or partially protected with fabrics, blackened with stove polish, or deprived of its circulation.

UNCLASSIFIED

SECURITY CLASSIFICATION OF THIS PAGE(When Data Entered)

FOREWORD

The vivarium of the United States Army Aeromedical Research Laboratory (USAARL) is fully accredited by the American Association for Accreditation of Laboratory Animal Care.

The animals used in this study were procured, maintained, and used in accordance with the Animal Welfare Act of 1970 and AR 70-18. In conducting the research described in this report, the investigators adhered to the "Guide for Laboratory Animal Facilities and Care," as promulgated by the Committee on the Guide for Laboratory Animal Resources, National Academy of Sciences, National Research Council.

All authors were research investigators at the USAARL during the conduct of the experiments described herein.

Dr. Wachtel is currently with the Department of Surgery, University of California, San Diego, School of Medicine, San Diego, California 92103.

Dr. Knox is currently with the Department of Physiology and Biophysics, Louisiana State University Medical Center School of Medicine, Shreveport, Louisiana 71130.

Dr. McCahan is currently with the Department of Toxicology and Criminal Investigation, State of Alabama, Enterprise, Alabama 36330.

The authors are indebted to COL Gilbert L. Raulston, VC, U. S. Army; LTC Basil Pruitt, MC, U. S. Army; M. Becker and Steven Stadnicki, Fort Lee, VA; Donald Biggerstaff, TUSA Training Aids Center, Fort Rucker, AL; Janice Speigner, John Barbaccia, C. D. Williams, Lynn Alford, Darolyn Perez-Poveda, James Hearn, Danny Carpenter, Charles Bishop, Bruce Donaldson, Malcolm Kirk, and all involved USAARL personnel for their generous assistance, without which this project could not have been completed.

ADMISSION BY	
OTIS	White Section <input checked="" type="checkbox"/>
SDC	Buff Section <input type="checkbox"/>
ONLINE/ONCE	<input type="checkbox"/>
JUSTIFICATION	
BY	
DISTRIBUTION/AVAILABILITY CODES	
Dist.	AVAIL. DTD. OR SPECIAL
A	

SUMMARY

A clinical grading system of severity of cutaneous burn was developed in a porcine cutaneous burn bioassay model using a flame thermal source. From surface appearance, color, sensation, tactile response, tenacity of hair anchoring, and appearance on cut section, a progression of the severity of burn injury was developed and documented with serial still photographs, high-speed cinephotomacrography, and clinical descriptions. Variations in this grading scheme were required for skin protected or partially protected with fabrics, blackened with stove polish, or deprived of its circulation.

APPROVED:



STANLEY C. KNAPP
Colonel, MC
Commanding

TABLE OF CONTENTS

	<u>Page</u>
List of Figures and Tables	iv
Introduction	1
Methods and Materials	1
Results	5
Discussion	16
References	19
Appendix A	21

LIST OF FIGURES AND TABLES

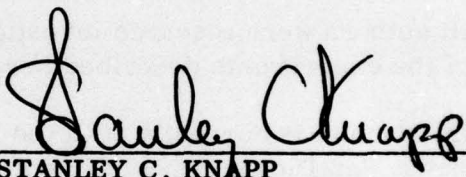
<u>Figure</u>	<u>Page</u>
1. USAARL T-1 Furnace (A) and Pneumatically Operated Water-Cooled Shutter System (B)	5
2. Computer Grade 1: Immediately Postburn (A) and 24 Hours Postburn (B)	7
3. Computer Grade 2: Immediately Postburn (A) and 24 Hours Postburn (B)	7
4. Computer Grade 3: Immediately Postburn (A) and 24 Hours Postburn (B)	8
5. Computer Grade 4: Immediately Postburn (A) and 24 Hours Postburn (B)	8
6. Computer Grade 5: Immediately Postburn (A) and 24 Hours Postburn (B)	9
7. Computer Grade 6: Immediately Postburn (A) and 24 Hours Postburn (B)	9
8. Computer Grade 7: Immediately Postburn (A) and 24 Hours Postburn (B)	10
9. Computer Grade 8: Immediately Postburn (A) and 24 Hours Postburn (B)	10
10. Computer Grade 9: Immediately Postburn (A) and 24 Hours Postburn (B)	11
11. Computer Grade 10: Immediately Postburn (A) and 24 Hours Postburn (B)	11
12. Computer Grade 11: Immediately Postburn (A) and 24 Hours Postburn (B)	12
13. Computer Grade 12: Immediately Postburn (A) and 24 Hours Postburn (B)	12

<u>Figure</u>	<u>Page</u>
14. Computer Grade 13: Immediately Postburn (A) and 24 Hours Postburn (B)	13
15. Computer Grade 14: Immediately Postburn (A) and 24 Hours Postburn (B)	13
16. Computer Grade 15: Immediately Postburn (A) and 24 Hours Postburn (B)	14
17. Computer Grade 16: Immediately Postburn (A) and 24 Hours Postburn (B)	14
18. Geographic distribution of the more severe burn (A) corresponds to area of fabric failure (B).	15
19. Superficial Thermal Injury of Porcine Skin Blackened with Stove Polish: Immediately Postburn (A) and 24 Hours Postburn (B)	15
20. Carbonized Burn Injury of Porcine Skin Blackened with Stove Polish: Immediately Postburn (A) and 24 Hours Postburn (B)	16

Table

1. Clinical Grading System - Immediate Evaluation	3
2. Clinical Grading System - 24-Hour Evaluation	4

INTRODUCTION

Thermal injury continues to be a problem in both military and civilian medical circles. The care of the burned patient is costly,^{1 2} and for this reason as well as for humanitarian considerations, prevention is still by far the best answer to the burn problem. This requires that, among other areas of burn prevention, flame retardant fabrics be developed and improved upon as the state of the art allows. Standard textile testing of flame retardant qualities has progressed to the point where additional biological analysis is required. To support the development of new mathematical modeling from thermal transfer equations and the future testing of fabrics and sensor devices, a bioassay method for burn analysis should be developed. Perkins, et al, have made a monumental contribution toward this end.³ We wish to utilize their basic framework and amplify and apply the bioassay method to thermal injury by conflagration.

Careful clinical observations and evaluations are used to assess the burn injury in human patients.⁴ This report describes a clinical grading system that can be employed in a porcine bioassay of thermal damage.

METHODS AND MATERIALS

One hundred forty-seven white domestic swine weighing 43 ± 8 kg were procured, quarantined, freed of internal and external parasites, and verified to be healthy prior to use in this study. The swine were fasted overnight, premedicated with Atropine (0.04 mg/kg) and fentanyl-droperidol (0.1 ml/kg) or phencyclidine hydrochloride (100 mg) and chlorpromazine hydrochloride (50 mg), intubated, and anesthetized with halothane USP or methoxyflurane.^{5 6} All hair was clipped closely with a #40 clipper head.⁷ When the cutaneous sensation had disappeared (determined by the scratch test), the animal was transported from the vivarium to the test site on a specially constructed transporting device. The experimental animal was maintained in Stage III anesthesia during exposure to the thermal source. The room temperatures were fairly stable although not constant; therefore, the skin temperature variations from the external environment were not accurately controlled.

The thermal source consisted of a flame gun (modified gun type-conversion oil burner) using kerosine fuel set to deliver 14 ± 0.5 BTU/ft²/sec,⁸ or a furnace (modified NASA-Ames T-3 furnace) using JP-4 fuel set to deliver 0.7 - 3.92 Kcal/cm²/sec.⁹ Each animal was protected from the thermal

source by a shutter system and template.^{8 9} The animal was placed against a laminated wood-transite template with circular, countersunk openings (1½ - 2 inches in diameter) which defined the exposure sites and areas. The time of exposure was controlled by an electrically activated solenoid air (and gravity and spring, also) driven shutter and ranged from 0.5 to 15 seconds.^{8 9} Thus, each animal received approximately 12-24 burn sites for a total of over 1,700 sites that were evaluated for this study.

The severity of the resultant cutaneous burn lesions was evaluated immediately and at 24 hours postburn using photographic techniques (still color photographs at constant focal length and light source and 16 mm high-speed motion pictures) and clinical observations for documentation. The surface appearance was graded immediately and at 24 hours by two physicians (a surgeon with experience at a burn center and an internist) and a veterinarian. The most severe, least severe, and overall grade were recorded for each burn site.

The scheme for grading the SURFACE APPEARANCE of burns developed by this laboratory closely parallels the work of the University of Rochester³ and is shown in Tables 1 and 2 (pages 3 and 4). In addition to the surface appearance, HAIR REMOVAL, SENSATION, TACTICLE RESPONSE, and APPEARANCE ON CUT SECTION were included.

To aid in the study of the progression of the cutaneous burn in porcine skin, high-speed 16 mm color movies were taken of several of the burn sites. The films were filtered to remove the colors of the fire. The film was reviewed frame by frame, and a description of the progressive severity of the burn wound helped form the basis for the grading system (Table 1, page 3).

In many of the test sites the skin was protected by a shell, fire retardant fabric or a shell, fire retardant fabric and an undergarment.^{8 9} In one substudy the skin of the animals was covered with black stove polish. In another substudy, dead animals (within one hour after death) were burned in exactly the same manner as the anesthetized animals had been burned.

TABLE 1
CLINICAL GRADING SYSTEM - IMMEDIATE EVALUATION

Computer Number	Laboratory Grade	Descriptive Term	Surface Appearance	Hair Removal	Additional Information	Burn Depth on Cut Section
1	0	Normal Skin	Normal Skin	Difficult	Normal Skin Pliable Pain to Needle Stick	Zero
2	1-		Mild Erythema (pink)	Difficult	Pliable, Painful, and Hot to Touch	Upper Epidermis 50% of Epidermis All Epidermis
3	1	Red Burn	Moderate Erythema (red)	Difficult		
4	1+		Severe Erythema (dark red or purple)	Difficult		
5	2-		Patchy Coagulation 10-30% White & 70-90% Red or Purple	Difficult	Pliable,	0-5% Dermis
6	2	Spotted White Burn	50% White (crests) & 50% Red or Purple (valleys)	Difficult	Painful, and	5-10% Dermis
7	2+		70-80% White (crests) & 20-30% Red or Purple (valleys)	Difficult	Hot to Touch	10-15% Dermis
8	3-		Uniform Coagulation >90% White <10% Red	Some Difficulty	Pliable,	25% Dermis
9	3	White Burn	Shiny or Opalescent White	Fairly Easy	Some Pain, and	75-80% Dermis
10	3+		Dull White or Tan: Dry Looking Surface	Easy	No Blebs	All Dermis, but epidermis attached on cutting
11	4-		Multiple vesicles that look like crumpled tissue paper	Very Easy	Pliable and No Pain	All Dermis + 1 mm fat discoloration Epithelium carries away
12	4	Steam Blebs	Raised delicate bleb	Very Easy		All Dermis + 1-2 mm fat
13	4+		Broken large delicate blebs	Very Easy		Dermis opalescent white coagulation 3-4 mm fat
14	5-		Charred blebs around periphery	Very easy but often burned off	Decreased Pliability No Pain	All Dermis 4-5 mm fat
15	5	Carbonation	50% charred, usually no blebs around periphery	Very easy but often burned off	No Pain, Nonpliable	All Dermis 5-6 mm fat
16	5+		>70% charred, no blebs	Very easy but often turned off	Hard and Nonpliable No Pain	All Dermis >6 mm fat

TABLE 2
CLINICAL GRADING SYSTEM - 24-HOUR EVALUATION

Computer Number	Laboratory Grade	Surface Appearance	Hair Removal	Additional Information	Burn Depth on Cut Section	Anatomical Depth
1	0	Normal Skin	Difficult	Pliable Normal Skin	Zero	No Burns
2	1-	Mild Erythema (pink)	Difficult	Painful		Epidermal
3	1	Moderate Erythema (red)	Difficult	Pliable		Epidermal
4	1+	Severe Erythema (dark red or purple)	Difficult		All Epidermis Dermis discolored	Epidermal
5	2-	Whitish crests 10-30% Red or purple valleys 70-90%	Difficult	Painful		Superficial
6	2	White crests 50% Red valleys 50%	Difficult	Pliable	30% Dermis reddish brown	Intradermal
7	2+	Mostly white 80% with few red valleys 20%	Difficult		40% Dermis	
8	3-	White	Some Difficulty	Cuts harder	50% Dermis	Deep Intradermal
9	3	White	Some Difficulty	Pliable	60% Dermis	Complete Dermal
10	3+	Light Brown or Tan	Easy		All dermis coagulated and fat slightly discolored	
11	4-	Majority of epithelium intact with <5 mm vesicles removed	Easy	Spotted and Leathery but cuts hard	All Dermis + 2 mm fatty discolor and hemorrhage	Subdermal
12	4	Areas of coagulation Red & White ("pepperoni")	Very Easy			Subdermal
13	4+	Purple & White (coagulated)	Very Easy		Coagulated and contracted	Subdermal
14	5-	Clear gelatin Surface with purple & white geographic pattern below	Very Easy		Hemorrhage into fat and discolored 5 mm deep	Subdermal
15	5	Hazy gelatin with nearly homogeneous faded purple white geographic pattern	Burned off or buried in coagulation			Subdermal
16	5+	Dark brown to black coagulated surface	Burned off or buried in coagulation			Subdermal

RESULTS

The animals tolerated the small burn sites without systematic or unusual local effects. The experimental apparatus on which the majority of the animals were tested, a rolling animal carriage with a pneumatically operated water-cooled shutter system placed over a furnace (Figure 1), worked very well.

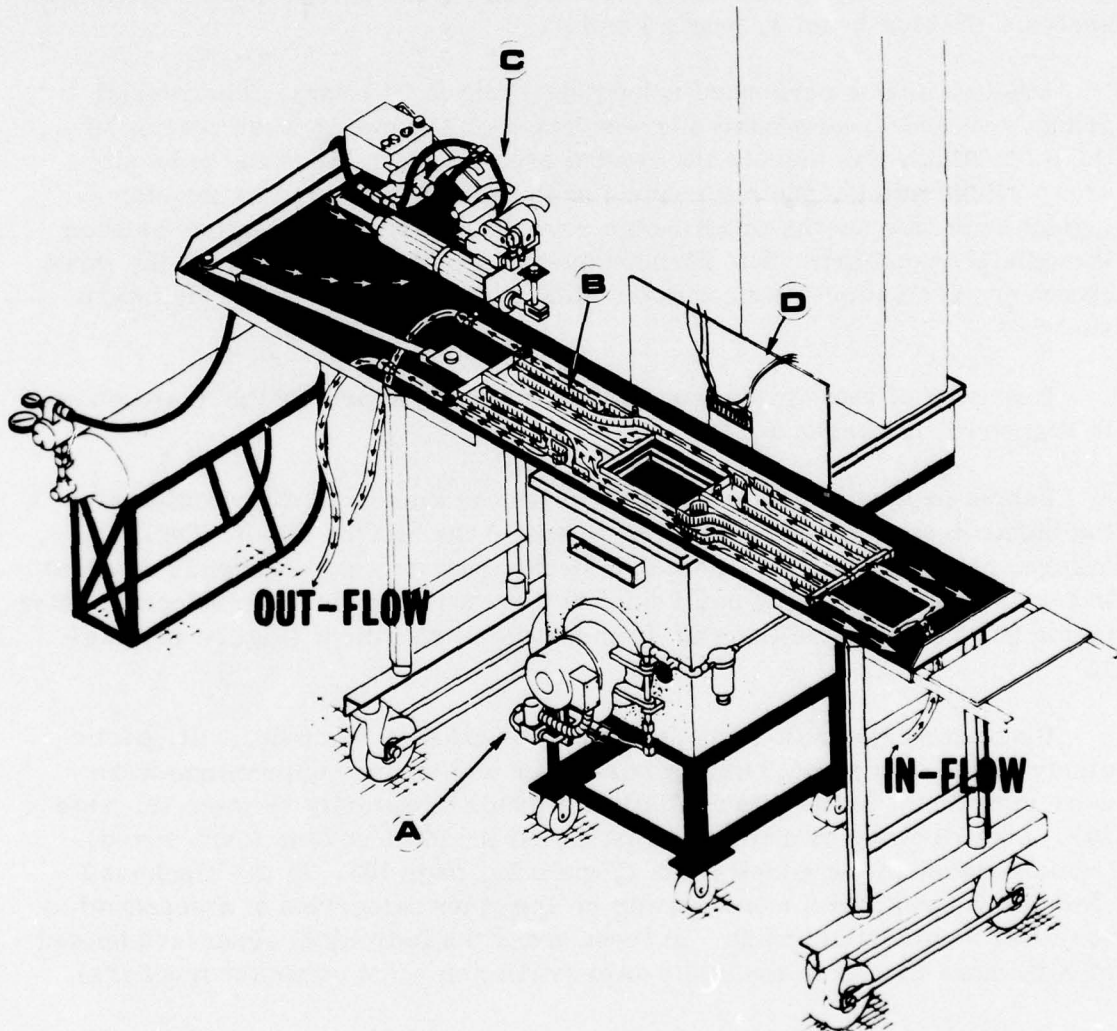

FIGURE 1. USAARL T-1 Furnace (A) and Pneumatically Operated Water-Cooled Shutter System (B).

The mildest surface damage was erythema, while the most severe was carbonation. In between, one also could detect patchy coagulation, uniform coagulation, and steam bleb. These conditions gave a basis for grading the burns into five main categories. Gradations of each of these major groups were discernible. Those burns that were slightly less severe than the average for the group were classified as minus (-) and those that were more severe as plus (+). This permitted less transition from one major group to another and facilitated preparing the gross evaluation for computer analysis (Tables 1 and 2, pages 3 and 4).

Evaluation was performed immediately and at 24 hours. The overall grade assessed to each burn site was based on the most severe portion of the burn which was usually the central area (at least 25% of the burn site area). Evaluation of the high-speed motion pictures helped us develop a logical sequence for the progressive severity of the thermal injury as seen immediately postburn. The 24-hour overall grade, a consensus of the three observers (variation <0.8 computer numbers), was used in the statistical analyses.

Examples of each grade immediately and at 24 hours postburn are shown in Figures 2-17 (pages 7-14).

Fabric protection caused a variation in the kinds and distribution of the burns depending on the manner in which the fabrics failed. Early failure, particularly when the fabric broke open or was destroyed, resulted in burns that were nearly equivalent to those without fabric interfaces. Later fabric failure protected the skin from severe burn injury (Figure 18, page 15).

Blackening the skin made the clinical evaluation more difficult, particularly in the superficial burns where color and surface appearance were more significant in the differentiation of grade of severity (Figure 19, page 15). Likewise, we probably overestimated the more severe (carbonized) burns because of the added color (Figure 20, page 16). In the blackened skin we had to depend more heavily on the other categories of assessment to arrive at a particular grade. In these areas the individual observers tended to vary more than with the white skin (variation = 1.4 computer numbers).

Dead animals showed a more severe grade of burn (approximately 2 to 3 computer numbers) for the same heat flux and exposure time than their living, anesthetized counterparts.

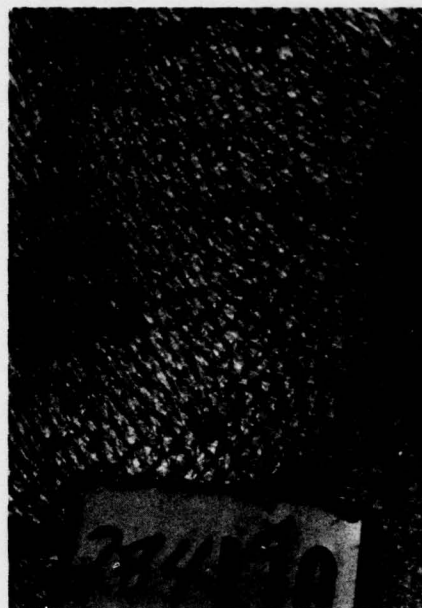
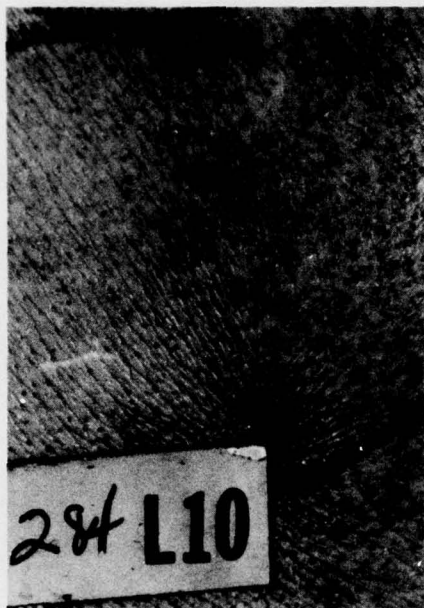

FIGURE 2. Computer Grade 1: Immediately Postburn (A) and 24 Hours Postburn (B).

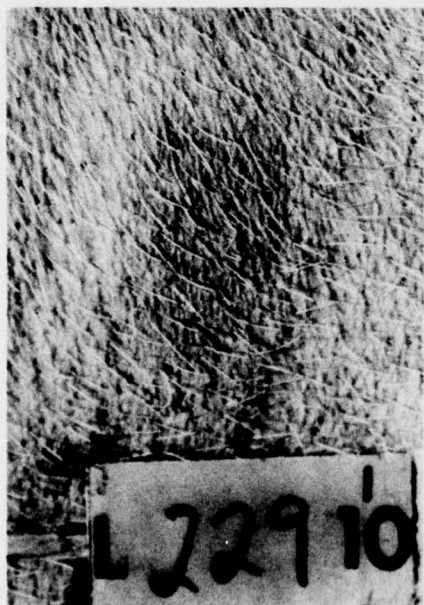

FIGURE 3. Computer Grade 2: Immediately Postburn (A) and 24 Hours Postburn (B).

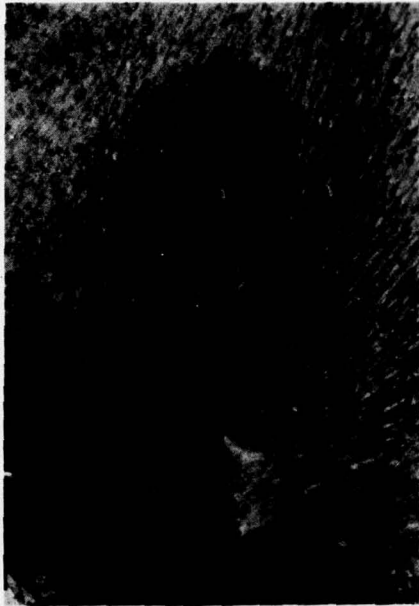

FIGURE 4. Computer Grade 3: Immediately Postburn (A) and 24 Hours Postburn (B).



FIGURE 5. Computer Grade 4: Immediately Postburn (A) and 24 Hours Postburn (B).

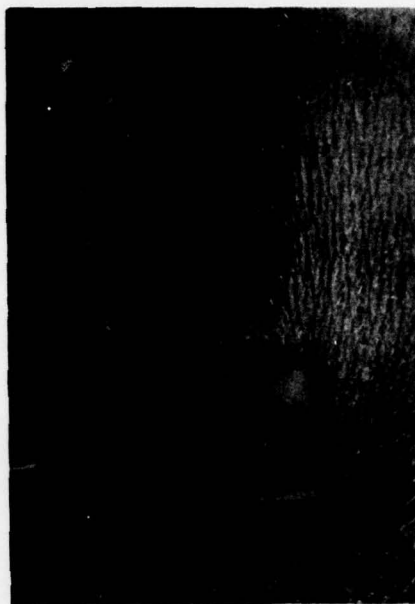
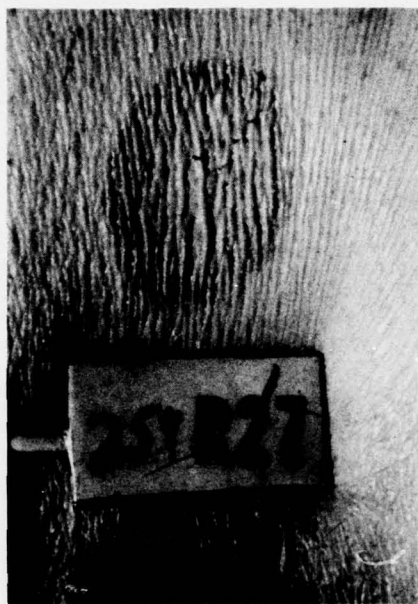

FIGURE 6. Computer Grade 5: Immediately Postburn (A) and 24 Hours Postburn (B).

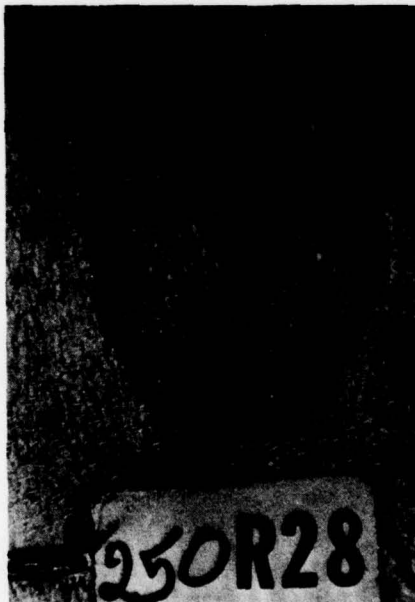
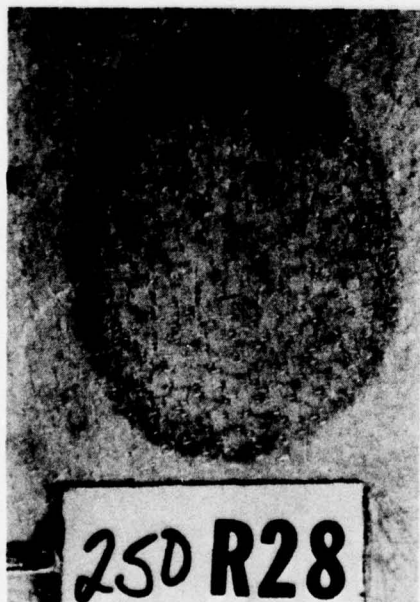

FIGURE 7. Computer Grade 6: Immediately Postburn (A) and 24 Hours Postburn (B).

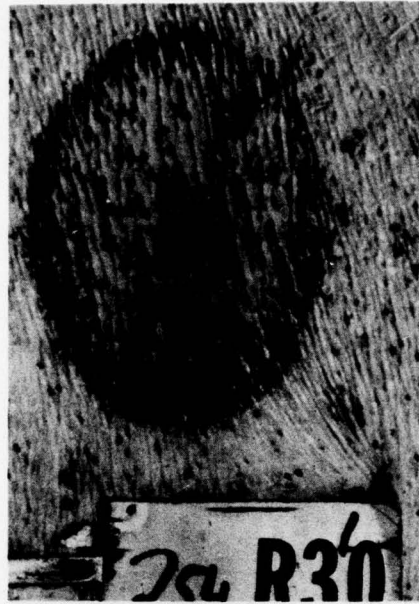

FIGURE 8. Computer Grade 7: Immediately Postburn (A) and 24 Hours Postburn (B).

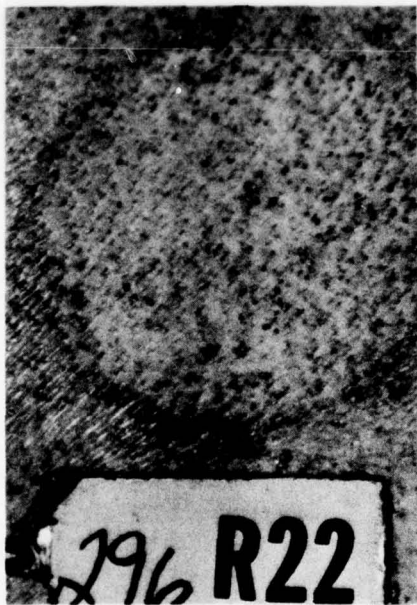

FIGURE 9. Computer Grade 8: Immediately Postburn (A) and 24 Hours Postburn (B).

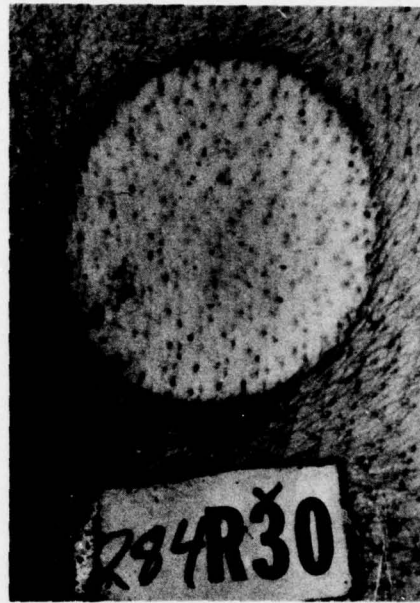
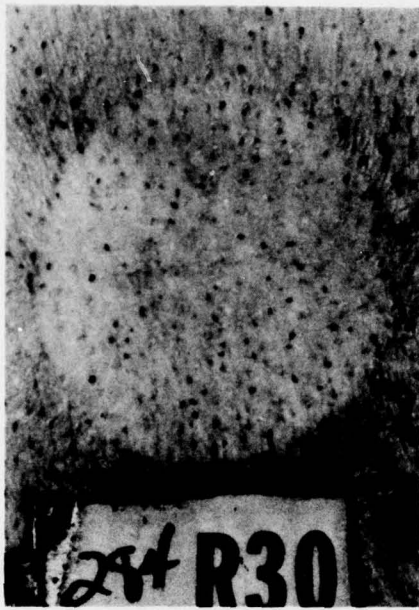

FIGURE 10. Computer Grade 9: Immediately Postburn (A) and 24 Hours Postburn (B).

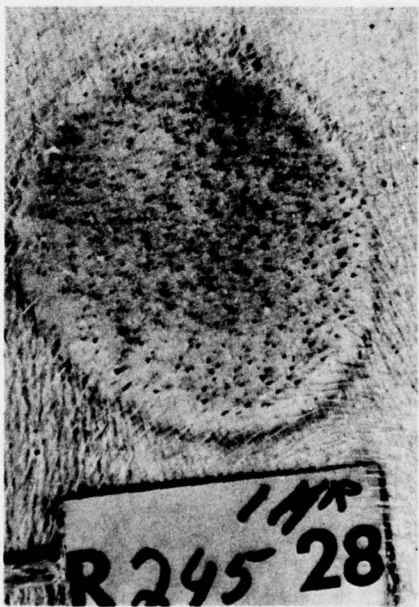

FIGURE 11. Computer Grade 10: Immediately Postburn (A) and 24 Hours Postburn (B).

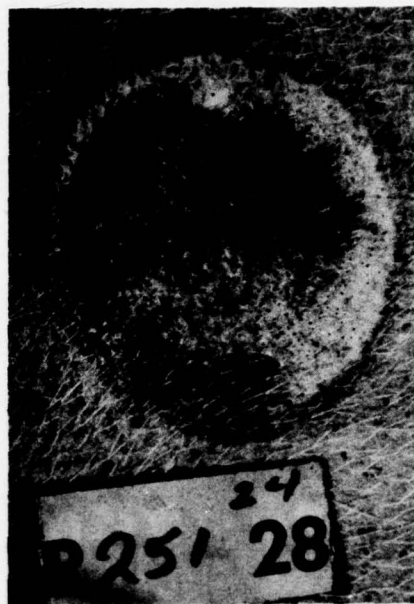

FIGURE 12. Computer Grade 11: Immediately Postburn (A) and 24 Hours Postburn (B).

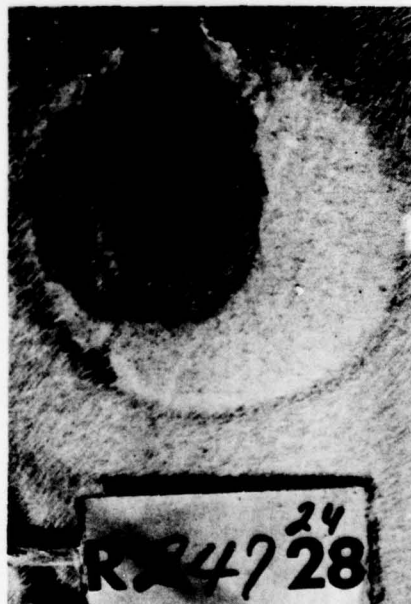

FIGURE 13. Computer Grade 12: Immediately Postburn (A) and 24 Hours Postburn (B).

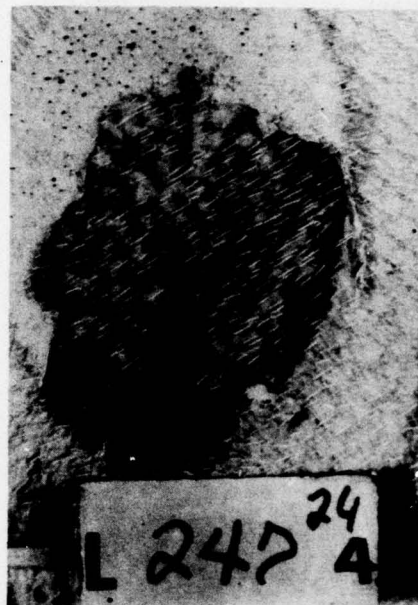
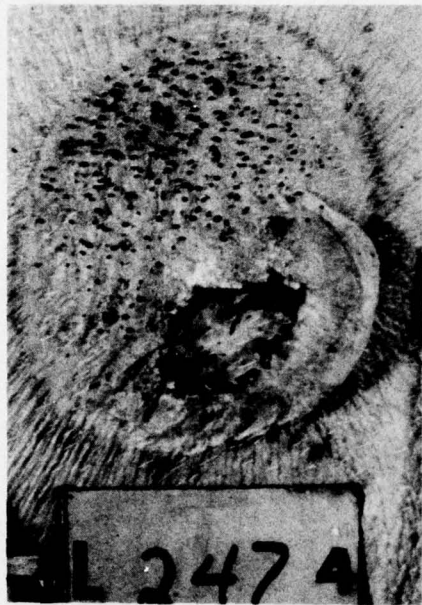

FIGURE 14. Computer Grade 13: Immediately Postburn (A) and 24 Hours Postburn (B).

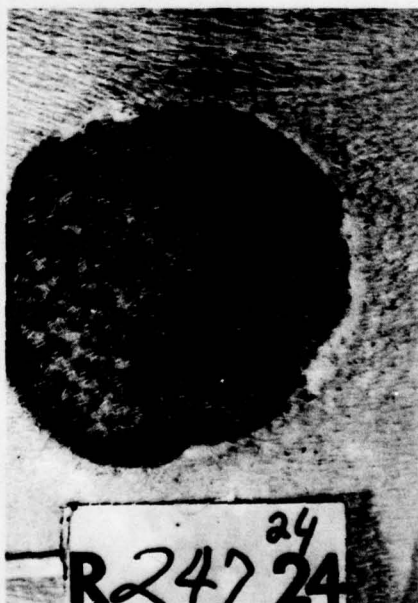

FIGURE 15. Computer Grade 14: Immediately Postburn (A) and 24 Hours Postburn (B).

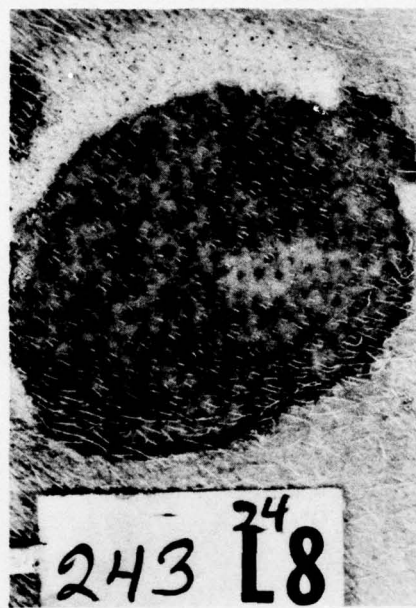
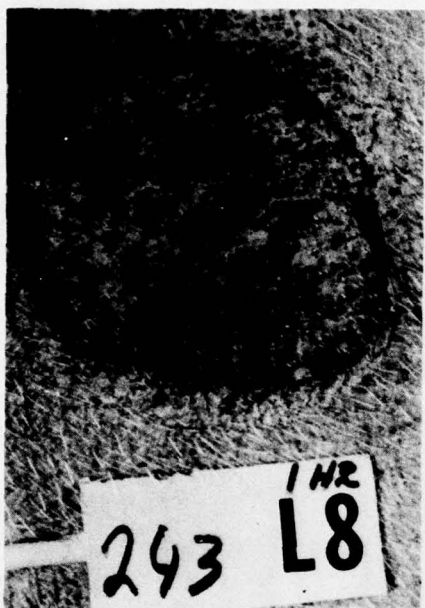

FIGURE 16. Computer Grade 15: Immediately Postburn (A) and 24 Hours Postburn (B).

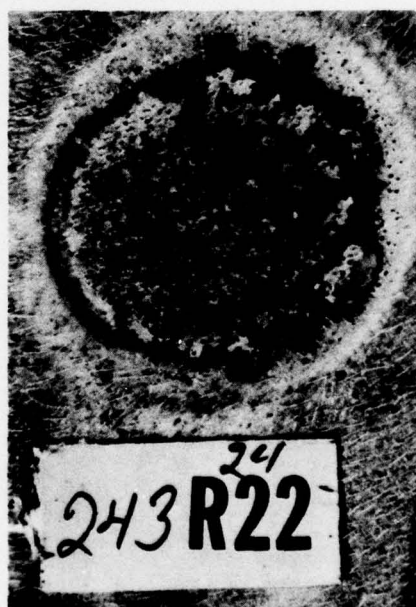

FIGURE 17. Computer Grade 16: Immediately Postburn (A) and 24 Hours Postburn (B).

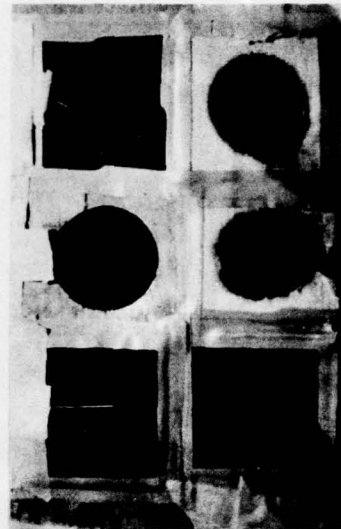
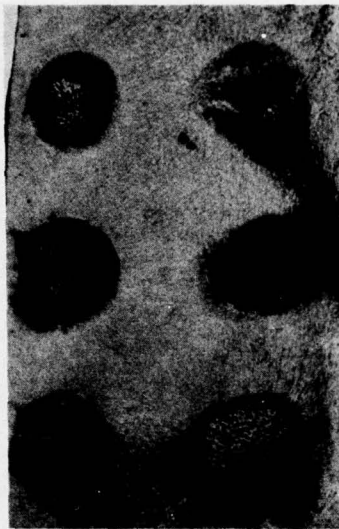

FIGURE 18. Geographic distribution of the more severe burn (A) corresponds to the area of fabric failure (B). Skin protected by the fire retardant fabric shows less severe burn.

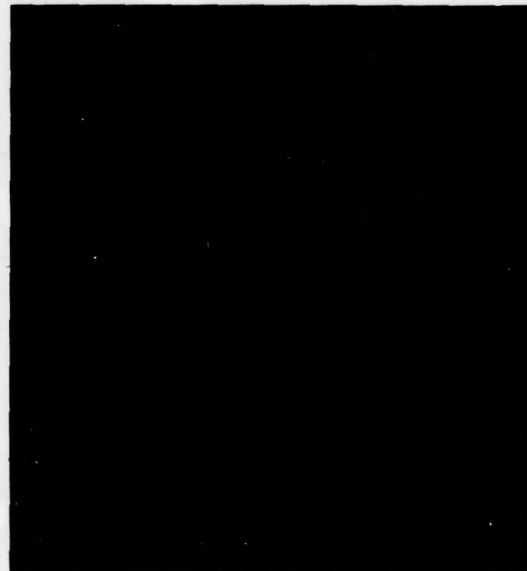

FIGURE 19. Superficial Thermal Injury of Porcine Skin Blackened with Stove Polish: Immediately Postburn (A) and 24 Hours Postburn (B).

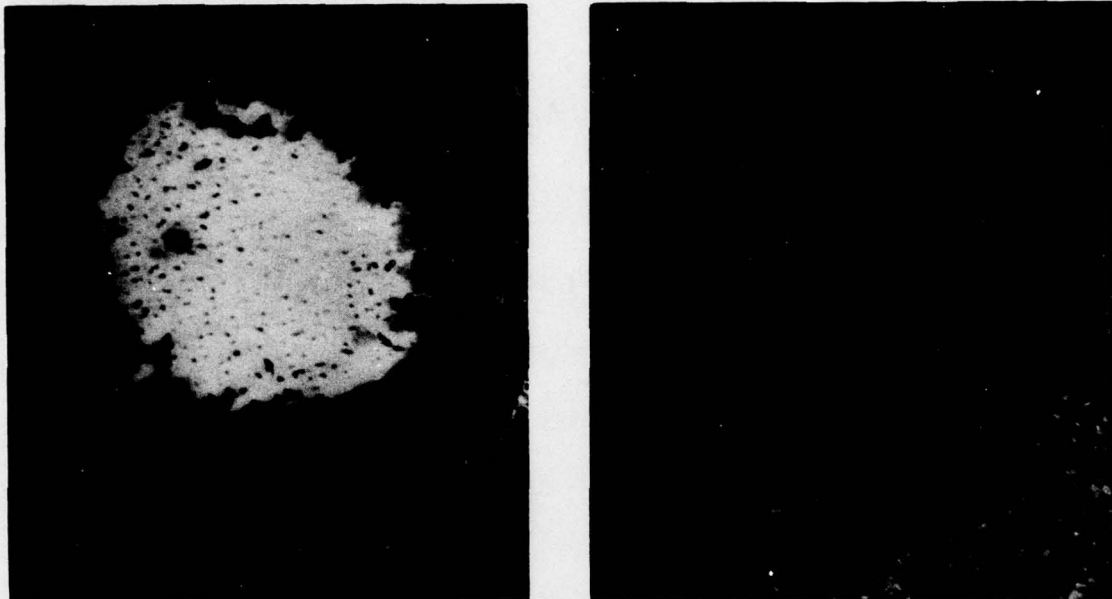

FIGURE 20. Carbonized Burn Injury of Porcine Skin Blackened with Stove Polish: Immediately Postburn (A) and 24 Hours Postburn (B).

DISCUSSION

Pigs were chosen because their skin more closely resembles human skin than any other commonly used or available laboratory animal.^{10 11 12} By review of the 16 mm motion film strips taken during the experimental exposures, one can study and classify changes as they are produced in the skin.¹³ Still photography provided an excellent method of documenting the burn wound changes, particularly as they relate to color changes of surface appearance. Clinical assessment encompassed several other standard techniques that are used in the clinical evaluation of the burned human victim (Tables 1 and 2, pages 3 and 4). Incising the burn wound gave an additional method of quantitation by allowing macroscopic determinations of burn wound depth (coagulation necrosis).

Laboratory grades 3, 4, and 5 were most easily assessed immediately postburn, while the less severe laboratory grades (1, 2, and 3) were more accurately assessed at 24 hours. The initial surface alteration on exposure to flame was a pink unstable lesion characterized by hyperemia (Figure 2A, page 7). This disappeared by the 24-hour evaluation (Figure 2B, page 7).

A slightly more severe stage was a stable erythema or red burn (Figure 3, page 7). The next level of severity was a purple circulostasic state that generally receded to an erythematous burn (Figure 4, page 8), or occasionally proceeded to the spotty red and green-yellow (in approximately equal amounts) patterns of patchy coagulation (Figure 6, page 9). The off-white (different from the usual white pigskin) color of uniform coagulation followed (Figure 9, page 10). The early appearance of crumpled tissue paper-looking steam blebs marked the end of the white burn (Figure 11, page 11). Steam blebs were gray, delicate, and broad-based with more severe burns beginning to show central or multifocal charred epithelium and hair stubble (Figure 13, page 12). As the severity progressed, the bleb was consumed and charring spread peripherally until the entire test site became charred and cadaveric (Figure 16, page 14). A change in the pliability was noted only moderately even at the 24-hour evaluation. Any hair stubble could be easily removed. Some burn lesions appeared to be even more severely carbonized and were nonpliable in the immediate and postburn evaluation (Figure 17, page 14). In these, no hair was present to be removed.

Although the less severe burns tended to improve slightly and the more severe burns tended to progress to a slightly worse grade from that observed in the immediate postburn evaluation, all burn test sites failed to deviate significantly after 24 hours (observed for 96 hours); thus, making the surface appearance during the serial studies essentially unchanged.

The 5 cm test sites were demarcated reasonably well with little edge effect at these short exposures to high intensity flame. They were circumscribed by a red ring (Figure 10, page 11) of about 2 mm in width. When a fabric or fabric combinations failed, several grades of burn could be identified within the same test site mimicking the fabric failure areas (Figure 18, page 15). When ceramic-covered thermocouples were used, they offered some protection from the more severe burns; but because of their ability to retain heat, they frequently produced erythema and patchy or uniform coagulation in the least severe burns.

When the skin was blackened, additional information was necessary to continue accurate grading (See Table 1, page 3). Pigment makes a significant difference in the heating of the skin.¹⁴ The severe burns (computer numbers 8-16) were still evaluated by surface appearance although computer numbers 7 to 10 were difficult to define. Feces, dirt, or fabric stain can modify the observer's ability to grade the burn injury. Hair was difficult to remove in computer numbers 1 to 6 and became easy to do in computer numbers 9 and above. Pliability and pain to needle stick were less

helpful. Cut section was not performed immediately on most animals, so it was of no use in reading burns except to standardize the grading system at 24 hours.

Hardy¹⁴ has shown that the blood circulation is important as a variable in the heat sink such that devascularized and excised skin showed more severe burns. Excised skin heats more rapidly. Our dead animals corroborated his results.

REFERENCES

1. Zilioli, A. E. "Crash injury economics: The costs of training and maintaining an Army aviator" (USAARL Report No. 71-77). Fort Rucker, AL: U. S. Army Aeromedical Research Laboratory, April 1971.
2. Zilioli, A. E. "Crash injury economics: Aircrewman injury and death costs occurring in UH-1 Army aircraft accidents in fiscal year 1969" (USAARL Report No. 71-18). Fort Rucker, AL: U. S. Army Aeromedical Research Laboratory, June 1971.
3. Perkins, J. B., Pearse, H. E., and Kingsley, H.D. "Studies on flash burns: The relation of the time and intensity of applied thermal energy to the severity of burns" (Atomic Energy Project Report UR-217). University of Rochester, 1952.
4. Artz, C. P., and Moncrief, J. A. The Treatment of Burns, 2d Edition. Philadelphia, PA: W. B. Saunders Company, 1969.
5. McCahan, G. R., Jr., and Wachtel, T. L. "Anesthesia or immobilization of domestic and miniature swine--methods and some problems" (USAARL Report No. 73-6). Fort Rucker, AL: U. S. Army Aeromedical Research Laboratory, December 1972.
6. Ragan, H. A., and Gillis, M. F. Restraint, venipuncture, endotracheal intubation and anesthesia of miniature swine. Laboratory Animal Science 25: 409-419, 1975.
7. Wachtel, T. L., and McCahan, G. R., Jr. "A comparison of methods of preparing porcine skin for bioassay of thermal injury" (USAARL Report No. 73-9). Fort Rucker, AL: U. S. Army Aeromedical Research Laboratory, March 1973.
8. Knox, F. S., III, McCahan, G. R., Jr., Wachtel, T. L., Trevethan, W. P., Martin, A. S., DuBois, D. R., and Keiser, G. S. "Engineering test of lightweight underwear of the winter flight clothing system: Thermal protection" (USAARL Report No. 71-19). Fort Rucker, AL: U. S. Army Aeromedical Research Laboratory, June 1971.
9. Knox, F. S., III, McCahan, G. R., Jr., and Wachtel, T. L. Use of the pig as a bioassay substrate for evaluation of thermally protective clothing and physical sensor calibration. Aerospace Medicine 45(8): 933-938, 1974.

10. Hinshaw, J. R., and Payne, F. W. The restoration and remodeling of the skin after a second degree burn. Surgery, Gynecology and Obstetrics 117: 738, 1963.
11. Montagna, W., and Yun, J. S. The skin of the domestic pig. Journal of Investigative Dermatology 42: 11, 1964.
12. Weinstein, G. D. Comparison of turnover time of keratinous protein fractions in swine and human epidermis. In L. K. Bustad and R. O. McClellan (Eds) Swine in Biomedical Research. Frayn, Seattle, 1966.
13. Robb, H. J. Dynamics of the microcirculation during a burn. Archives of Surgery 94: 776, 1967.
14. Hardy, J. D. Physiological effects of high intensity infrared heating. ASHRAE Journal, November 1962.
15. Morton, J. H., Kingsley, H. D., and Pearse, H. E. Studies on flash burns: Threshold burns. Surgery, Obstetrics and Gynecology, 1952.
16. Berkley, K. M. "Evaluation of surface appearance of burns by depth of damage" (Atomic Energy Project Report UR-337). University of Rochester, 1954.

APPENDIX A

LIST OF EQUIPMENT

Veterinary

1. Heidbrink Model 970 - Veterinary Anesthesia Unit
2. CAP-CHUR Equipment (Palmer Chemical & Equipment Company)
3. Drugs
 - a. Sernylan (phencyclidine hydrochlorida - Park-Davis)
 - b. Thorazine (chlorpromazine - Pitman-Moore)
 - c. Penthrane (methoxyflurane - Abbot)
 - d. Atropine Sulfate
 - e. Innovar-Vet (fentanyl-droperidol)

Experimental Apparatus

1. Flame gun - Conversion oil burner, modified Lennox, Model OB-32 (loaned by the National Aviation Flight Engineering Center, NAFEC, Atlantic City, New Jersey) that burned kerosene.
2. USAARL T-1 Furnace (NASA-Ames T-3 Designed by Richard Fish - modified and built by Lynn Alford - insulating fire brick lined steel box heated by a commercial oil burner (Ray Burner Co., Type RCR, Size 00-1) that burned JP-4.

Other

1. Black Silk Stove Polish - J. L. Prescott Co., Passaic, New Jersey.
2. Nextel 3M

DISTRIBUTION LIST FOR USAARL REPORTS

Defense Documentation Center Alexandria, VA 22314	(12)	Aeromechanics Laboratory US Army Research & Technology Labs Ames Research Center, M/S 215-1 Moffett Field, CA 94035	(1)
Director of Defense, Research and Engineering ATTN: Assistant Director (Environmental & Life Sciences) Washington, DC 20301	(1)	Sixth United States Army ATTN: SMA Presidio of San Francisco, California 94129	(1)
Uniformed Services University of the Health Sciences 4301 Jones Bridge Road Bethesda, MD 20014	(1)	Director Army Audiology & Speech Center Walter Reed Army Medical Center Forest Glen Section, Bldg 156 Washington, DC 20012	(1)
Commander US Army Medical Research and Development Command ATTN: SGRD-AJ (Mrs. Madigan) Fort Detrick Frederick, MD 21701	(5)	US Army Materiel Command Harry Diamond Laboratories Scientific & Technical Information Offices 2800 Powder Mill Road Adelphi, MD 20783	(1)
Redstone Scientific Information Center DRDMI-TBD US Army Missile R&D Command Redstone Arsenal, AL 35809	(1)	US Army Ordnance Center & School Library, Bldg 3071 ATTN: ATSL-DOSL Aberdeen Proving Ground, MD 21005	(1)
US Army Yuma Proving Ground Technical Library Yuma, AZ 85364	(1)	US Army Environmental Hygiene Agency Library, Bldg E2100 Aberdeen Proving Ground, MD 21010	(1)
US Army Aviation Engineering Flight Activity ATTN: DAVTE-M (Technical Library) Edwards AFB, CA 93523	(1)	Technical Library Chemical Systems Laboratory Aberdeen Proving Ground, MD 21010	(1)
US Army Combat Developments Experimentation Command Technical Library HQ, USACDEC Box 22 Fort Ord, CA 93941	(1)		

US Army Materiel Systems Analysis Agency ATTN: Reports Distribution Aberdeen Proving Ground, MD 21005	(1)	Chief Benet Weapons Laboratory LCWSL, USA ARRADCOM ATTN: DRDAR-LCB-TL Watervliet Arsenal Watervliet, NY 12189	(1)
Director Biomedical Laboratory Aberdeen Proving Ground, MD 21010	(1)	US Army Research & Technology Labs Propulsion Laboratory MS 77-5 NASA Lewis Research Center Cleveland, OH 44135	(1)
HQ, First United States Army ATTN: AFKA-MD (Surgeon's Ofc) Fort George G. Meade, MD 20755	(1)	US Army Field Artillery School Library Snow Hall, Room 16 Fort Sill, OK 73503	(1)
Director Ballistic Research Laboratory ATTN: DRDAR-TSB-S (STINFO) Aberdeen Proving Ground, MD 21005	(2)	US Army Dugway Proving Ground Technical Library Bldg 5330 Dugway, UT 84022	(1)
US Army Research & Development Technical Support Agency Fort Monmouth, NJ 07703	(1)	US Army Materiel Development & Readiness Command ATTN: DRCSG 5001 Eisenhower Avenue Alexandria, VA 22333	(1)
CDR/DIR US Army Combat Surveillance & Target Acquisition Laboratory ATTN: DELCS-D Fort Monmouth, NJ 07703	(1)	US Army Foreign Science & Technology Center ATTN: DRXST-IS1 220 7th St., NE Charlottesville, VA 22901	(1)
US Army Avionics R&D Activity ATTN: DAVAA-O Fort Monmouth, NJ 07703	(1)	US Army Training & Doctrine Command ATTN: ATCD Fort Monroe, VA 23651	(2)
US Army White Sands Missile Range Technical Library Division White Sands Missile Range New Mexico 88002	(1)	Commander US Army Training & Doctrine Command ATTN: Surgeon Fort Monroe, VA 23651	(1)

US Army Research & Technology Labs Structures Laboratory Library NASA Langley Research Center Mail Stop 266 Hampton, VA 23665	(1)	Commander US Army Health Services Command ATTN: Library Fort Sam Houston, TX 78234	(1)
Commander 10th Medical Laboratory ATTN: DEHE (Audiologist) APO New York 09180	(1)	Commander US Army Academy of Health Sciences ATTN: Library Fort Sam Houston, TX 78234	(1)
Commander US Army Natick R&D Command ATTN: Technical Librarian Natick, MA 01760	(1)	Commander US Army Airmobility Laboratory ATTN: Library Fort Eustis, VA 23601	(1)
Commander US Army Troop Support & Aviation Materiel Readiness Command ATTN: DRSTS-W St. Louis, MO 63102	(1)	Air University Library (AUL/LSE) Maxwell AFB, AL 36112	(1)
Commander US Army Aviation R&D Command ATTN: DRDAV-E P. O. Box 209 St. Louis, MO 63166	(1)	US Air Force Flight Test Center Technical Library, Stop 238 Edwards AFB, CA 93523	(1)
Commander US Army Human Engineering Laboratory ATTN: Technical Library Aberdeen Proving Ground, MD 21005	(1)	US Air Force Armament Development & Test Center Technical Library Eglin AFB, FL 32542	(1)
Commander US Army Aviation Research & Development Command ATTN: Library P. O. Box 209 St. Louis, MO 63166	(1)	US Air Force Institute of Technology (AFIT/LDE) Bldg 640, Area B Wright-Patterson AFB, OH 45433	(1)
		US Air Force Aerospace Medical Division School of Aerospace Medicine Aeromedical Library/TSK-4 Brooks AFB, TX 78235	(1)
		Director of Professional Services Office of The Surgeon General Department of the Air Force Washington, DC 20314	(1)

<p>Human Engineering Division 6570th Aerospace Medical Research Laboratory ATTN: Technical Librarian Wright-Patterson AFB, OH 45413 (1)</p>	<p>US Navy Naval Air Development Center Technical Information Division Technical Support Department Warminster, PA 18974 (1)</p>
<p>US Navy Naval Weapons Center Technical Library Division Code 2333 China Lake, CA 93555 (1)</p>	<p>Human Factors Engineering Division Aircraft & Crew Systems Technology Directorate Naval Air Development Center Warminster, PA 18974 (1)</p>
<p>US Navy Naval Aerospace Medical Institute Library Bldg 1953, Code 012 Pensacola, FL 32508 (1)</p>	<p>US Navy Naval Research Laboratory Library Shock & Vibration Information Center Code 8404 Washington, DC 20375 (1)</p>
<p>US Navy Naval Submarine Medical Research Lab Medical Library, Naval Submarine Base Box 900 Groton, CT 06340 (1)</p>	<p>Director of Biological & Medical Sciences Division Office of Naval Research 800 N. Quincy Street Arlington, VA 22217 (1)</p>
<p>Director Naval Biosciences Laboratory Naval Supply Center, Bldg 844 Oakland, CA 94625 (1)</p>	<p>Commanding Officer Naval Medical R&D Command National Naval Medical Center Bethesda, MD 20014 (1)</p>
<p>Naval Air Systems Command ATTN: V/STOL Aircraft Branch Department of the Navy Washington, DC 20360 (1)</p>	<p>Commander Naval Aeromedical Research Laboratory Detachment P. O. Box 29407 Michoud Station New Orleans, LA 70129 (1)</p>
<p>US Navy Naval Research Laboratory Library Code 1433 Washington, DC 20375 (1)</p>	<p>Federal Aviation Administration Office of Aviation Medicine Civil Aeromedical Institute ATTN: Library Oklahoma City, OK 73101 (1)</p>

Department of Defence
R.A.N. Research Laboratory
P. O. Box 706
Darlinghurst, N.S.W. 2010
Australia

(1)

FORT RUCKER DISTRIBUTION

Commander
US Army Aviation Center and
Fort Rucker
ATTN: ATZQ-CDR
Bldg 114

(1)

Commander
US Army Aviation Center and
Fort Rucker
ATTN: ATZQ-T-ATL
Bldg 5907

(1)

Chief
US Army Research Institute Field
Unit
Bldg 501

(1)

Director
Directorate of Combat Developments
Bldg 507

(1)

Commander
US Army Aeromedical Center
Bldg 301

(3)

Commander
US Army Safety Center
Bldg 4905

(1)

Director
Directorate of Training Developments
Bldg 502

(1)

President
US Army Aviation Board
Cairns AAF, Bldg 501AB

(1)

Commander
US Army Aircraft Development Test
Activity
Cairns AAF, Bldg 30601

(1)