

AD-A069 340

RAYTHEON CO WALTHAM MASS RESEARCH DIV
MANUFACTURING METHODS AND TECHNOLOGY PROGRAM ZINC SELENIDE BLAN--ETC(U)
FEB 79 R N DONADIO, J F CONNOLLY
DAAB07-78-C-2038

F/G 20/6

UNCLASSIFIED

S-2483

NL

1 of 1

AD
A069340

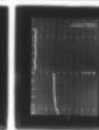
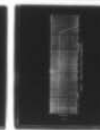

END

DATE

FILMED

7-79

DDC

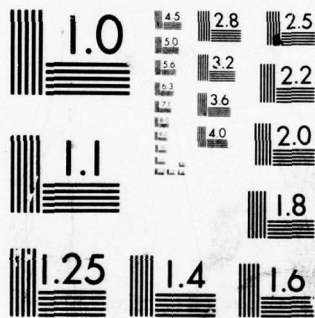

MICROCOPY RESOLUTION TEST CHART
NATIONAL BUREAU OF STANDARDS-1963-A

12

LEVEL #

AD A 069340

Second Quarterly Progress Report

8033610

MANUFACTURING METHODS & TECHNOLOGY PROGRAM
ZINC SELENIDE BLANKS FOR WINDOWS AND LENS ELEMENTS

1 November 1978 to 31 January 1979

Placed by
US Army Electronics Research & Development Command
Night Vision and Electro-Optics Laboratory
Fort Belvoir, VA 22060

Contract No. DAAB07-78-C-2038

DDC
RECEIVED
JUN 4 1979
RESERVED

✶ A

Approved for public release; distribution unlimited

DDC FILE COPY

Contractor
Raytheon Company
Research Division
Waltham, Massachusetts 02154

79 05 30 204

NOTICES

Disclaimers

The findings in this report are not to be considered as an official Department of the Army position, unless so designated by other authorized documents.

Disposition

Destroy this report when it is no longer needed. Do not return it to the originator.

Acknowledgement Statement

"This project has been accomplished as part of the US Army (Manufacturing and Technology) Program, which has as its objective the timely establishment of manufacturing processes, techniques or equipment to insure the efficient production of current or future defense programs."

Accession For	
RING GMAI	<input checked="" type="checkbox"/>
DLC TAB	
Unknowneed Justification	
By _____	
Distribution/	
Availability Codes	
Dist.	Avail and/or special
A	

UNCLASSIFIED

SECURITY CLASSIFICATION OF THIS PAGE (When Data Entered)

REPORT DOCUMENTATION PAGE		READ INSTRUCTIONS BEFORE COMPLETING FORM
1. REPORT NUMBER DAAB07-78-C-2038	2. GOVT ACCESSION NO. (and)	3. RECIPIENT'S CATALOG NUMBER 9
4. TITLE (and Subtitle) 6 Manufacturing Methods & Technology Program Zinc Selenide Blanks for Windows and Lens Elements		5. TYPE OF REPORT & PERIOD COVERED Quarterly Progress report no. 2 1 Nov 78 - 31 Jan 79
7. AUTHOR(s) 10 R. N. Donadio J. F. Connolly		6. PERFORMING ORGANIZATION REPORT NUMBER 14 S-2483
9. PERFORMING ORGANIZATION NAME AND ADDRESS Raytheon Research Division 28 Seyon St. Waltham, MA 02154		8. CONTRACT OR GRANT NUMBER(s) 15 DAAB07-78-C-2038
11. CONTROLLING OFFICE NAME AND ADDRESS US Army Electronics R&D Command Night Vision and Electro-Optics Laboratory DELNV-SI, Fort Belvoir, VA 22060		10. PROGRAM ELEMENT, PROJECT, TASK AREA & WORK UNIT NUMBERS Project No. 2789841
14. MONITORING AGENCY NAME & ADDRESS (if different from Controlling Office) 12 29p.		12. REPORT DATE 11 Feb 1979
		13. NUMBER OF PAGES 18
		15. SECURITY CLASS. (of this report) UNCLASSIFIED
		15a. DECLASSIFICATION/DOWNGRADING SCHEDULE
16. DISTRIBUTION STATEMENT (of this Report) Approved for public release; distribution unlimited.		
17. DISTRIBUTION STATEMENT (of the abstract entered in Block 20, if different from Report)		
18. SUPPLEMENTARY NOTES		
19. KEY WORDS (Continue on reverse side if necessary and identify by block number) Infrared Materials Zinc Selenide Chemical Vapor Deposition High Volume Manufacture		
20. ABSTRACT (Continue on reverse side if necessary and identify by block number) Two full-scale zinc selenide deposits were successfully conducted using the evaporator system. The optical and mechanical quality of the material produced appears to be the equivalent of that made in the reservoir system.		

298 320

Lu

**MANUFACTURING METHODS & TECHNOLOGY PROGRAM
ZINC SELENIDE BLANKS FOR WINDOWS AND LENS ELEMENTS**

**Second Quarterly Progress Report
1 November 1979 to 31 January 1979**

Object of Study

The objective of this manufacturing methods and technology program is to establish the capability to manufacture high volume zinc selenide blanks for infrared windows and lens elements.

Contract No. DAAB07-78-C-2038

B-033-610

Distribution Statement

Approved for public release; distribution unlimited

ABSTRACT

Two full-scale zinc selenide deposits were successfully conducted using the evaporator system. The optical and mechanical quality of the material produced appears to be the equivalent of that made in the reservoir system.

TABLE OF CONTENTS

	<u>Page</u>
1.0 PURPOSE	1
2.0 NARRATIVE AND DATA	3
2.1 Pre-Engineering Deposit	3
2.2 Engineering Sample Deposit	10
2.2.1 Sample requirements	10
2.2.2 Deposition	11
2.2.3 Tests on engineering samples	11
2.3 Substrate Modifications	15
3.0 MEETINGS	15
4.0 CONCLUSIONS	18
5.0 PROGRAM FOR THE NEXT INTERVAL	18
6.0 PUBLICATIONS	18
7.0 PERSONNEL	18

LIST OF ILLUSTRATIONS

	<u>Page</u>
1 Zinc Selenide Compensating Lens	2
2 Thickness Profile, Plate A, Pre-Engineering Deposit	5
3 Infrared Transmittance, Plate C, Pos. 2M, $t = 0.261$ in.	6
4 Infrared Transmittance, Plate D, Pos. 28M, $t = 0.278$ in.	7
5 Infrared Transmittance, Plate D, Pos. 52M, $t = 0.120$ in.	8
6 Thickness Profile, Plate A, Engineering Deposit	12
7 Infrared Transmittance of Sample ENG-1	13
8 Transmittance from 0.6 to 1.1 μm of Sample ENG-1	14
9 Curved Mandrel	17

GLOSSARY

Absorption Coefficient - Fraction of energy lost while traversing a path-length of one centimeter through a material.

Chemical Vapor Deposition - A process by which chemicals are reacted in the vapor phase to form a compound.

Deposition Temperature - Temperature of the reaction zone in which the chemical vapor deposition takes place.

Evaporator - Apparatus used to form a vapor (or gas) from a solid (or liquid).

Flexural Strength - Maximum fiber stress a material will withstand before rupture in bending.

Image Spoiling Characteristics - That property of a transparent material that defines the ability to resolve discrete images.

Retort - High temperature container used to hold liquid zinc.

Substrate - A form on which material is deposited, sometimes called a mandrel.

Zinc Reservoir System - Apparatus containing one or several liquid zinc retorts and associated monitoring and controlling devices.

1.0 PURPOSE

The purpose of this manufacturing and methods technology program is to establish an automated production process for the fabrication of high optical quality zinc selenide.

The program is of seventeen months duration and is sponsored by the United States Army Electronics Research and Development Command. It addresses itself to the further automation of an existing production process for the chemical vapor deposition of zinc selenide. Raytheon Company has successfully developed the techniques and facilities to fabricate state-of-the-art CVD zinc selenide in large sizes. It is anticipated that with improvements in automated processing the price for standard size lens blanks will be reduced to 50 percent of the catalog price. In addition, the use of a curved substrate may further reduce the price of the color correcting lens shown in Figure 1 to less than \$200 each for large volume purchases.

The program has been divided into three phases. In the first phase, zinc selenide test blanks will be produced using the existing process. In Phase II of the program the zinc reservoir system will be replaced with an automated external zinc supply, and blanks will be deposited for confirmation of the optical and mechanical characteristics of the material. The third phase of the program will demonstrate the production capability of a pilot line to manufacture high-quality zinc selenide blanks at four-hundred and eight-one (481) units per month.

PBN-79-126

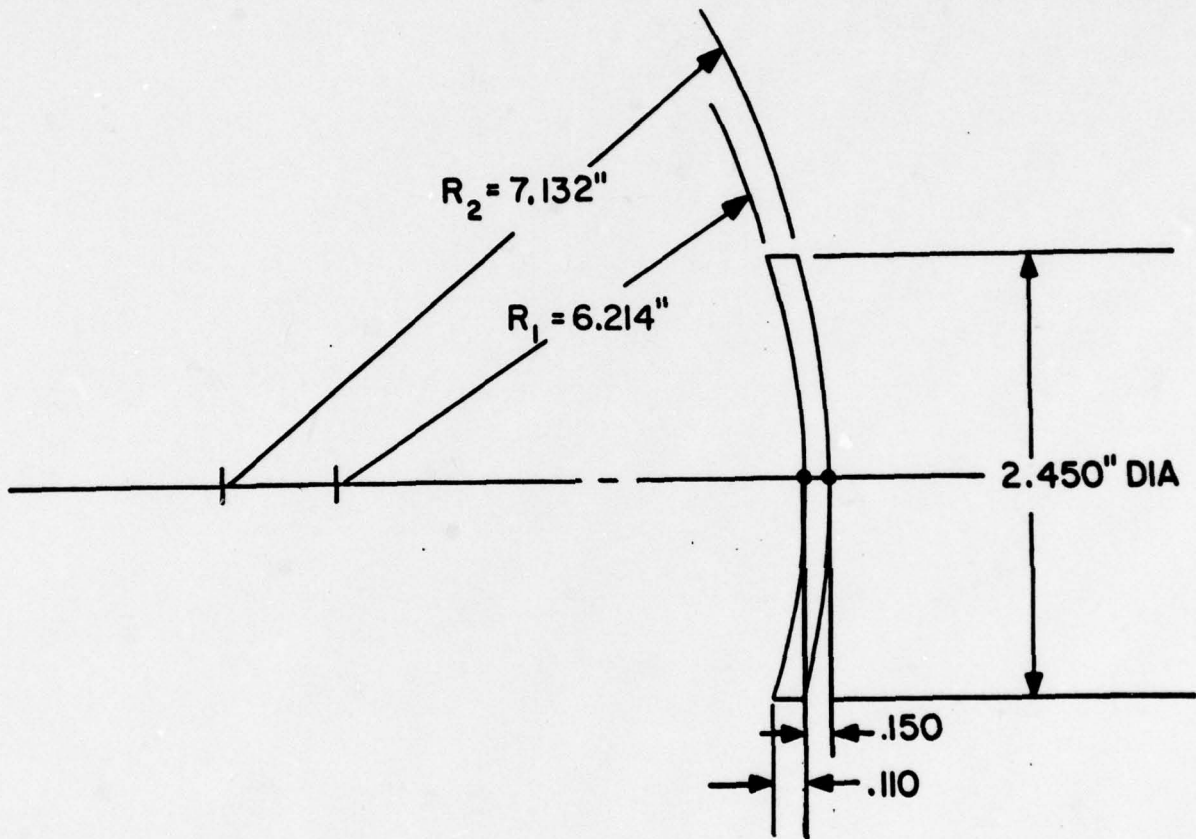

Figure 1. Zinc Selenide Compensating Lens.

2.0 NARRATIVE AND DATA

2.1 Pre-Engineering Deposit

An 84 hour zinc selenide deposit was conducted prior to the engineering sample deposit to further evaluate the performance of the deposition system. It was also felt that a moderately long run should be made to yield zinc selenide with sufficient thickness to measure the optical and mechanical properties of material made by this new method. The deposit was made in a 17 by 9 by 60 inch graphite box mandrel. The deposition conditions for this pre-engineering deposit are presented in Table 1.

The resultant deposit showed adequate overall thickness and thickness distribution. Figure 2 displays a thickness profile for Plate A, one of the two 17 by 60 inch plates deposited. Test samples were taken from the top, middle, and bottom of the deposited plates and tested for infrared transmittance. Figures 3 thru 5 present the infrared transmittance curves for these three locations. The average absorption coefficient (including surface absorption) was measured at 0.001 cm^{-1} .

Flexural test specimens were prepared from the top and bottom sections of the deposit. The zinc selenide was fabricated into $1/8$ by $1/4$ by $2\text{-}\frac{1}{4}$ inch beams and tested in flexure, using 4-point loading over a 2 in. span. The results presented in Table 2 show slightly higher strength values than typically observed. The 730°C deposition temperature for this deposit is the main factor for the increase in strength. A finer grained structure is produced at this lower deposition temperature, yielding a higher fracture strength. (Standard deposition temperature for zinc selenide is 750°C ; producing ~ 7500 psi fracture strength with optimum optical properties.)

Examination of the evaporation system after the deposit showed no evidence of leakage to the surrounding furnace, nor zinc condensate in the evaporator chain. No malfunctions of any kind were detected throughout the deposit.

TABLE 1

DEPOSITION CONDITIONS

<u>Run No.</u>	<u>Temp (°C)</u>	<u>Furnace Pressure (torr)</u>	<u>H₂Se Usage (lpm)</u>	<u>Zinc Usage (lpm)</u>	<u>Deposition Time (hrs)</u>
Pre-enginrg	730	24	4.0	700	84
Engrg. deposit	730	24	4.2	735	327

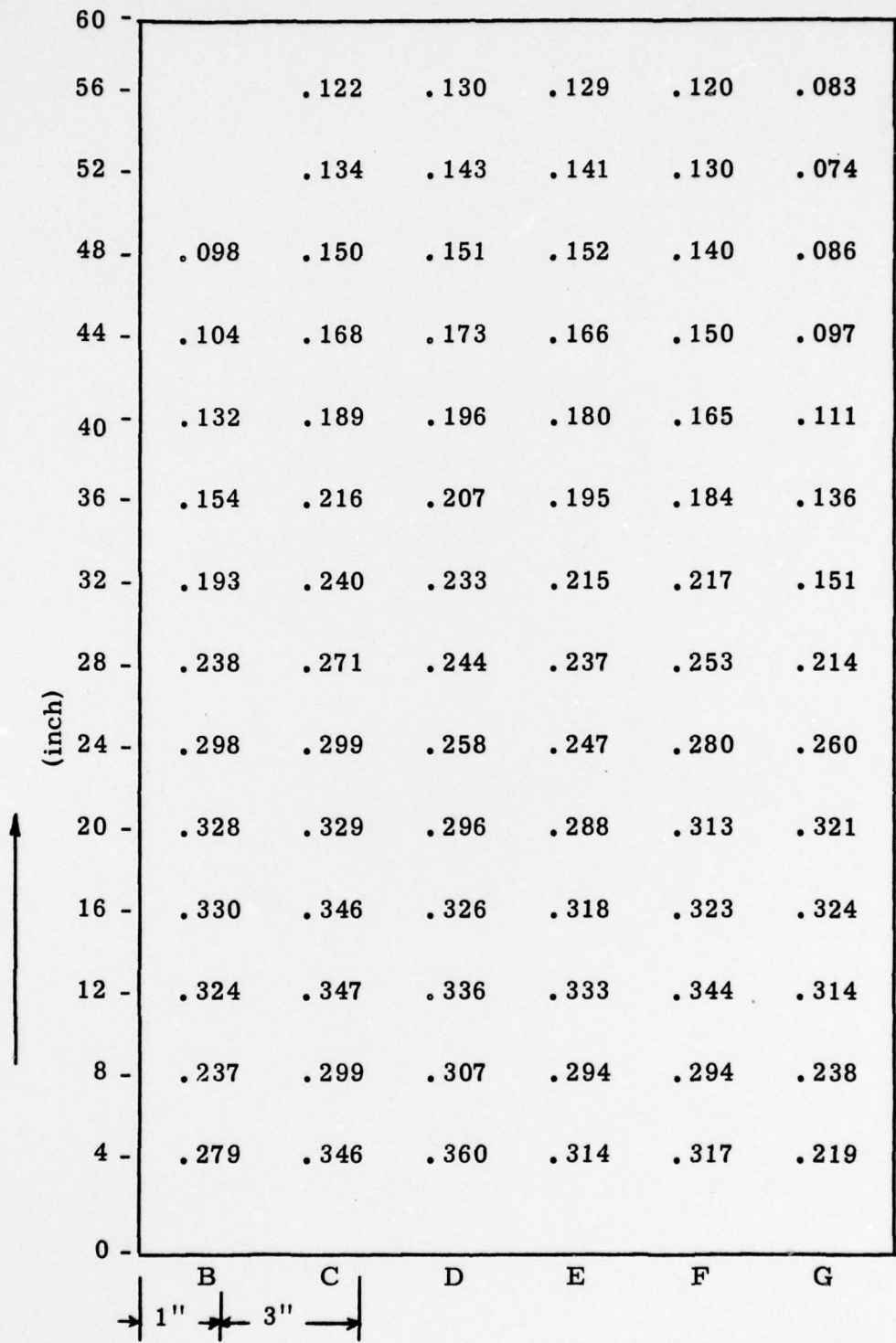

Figure 2. Thickness profile, Plate A
Pre-Engineering Deposit.

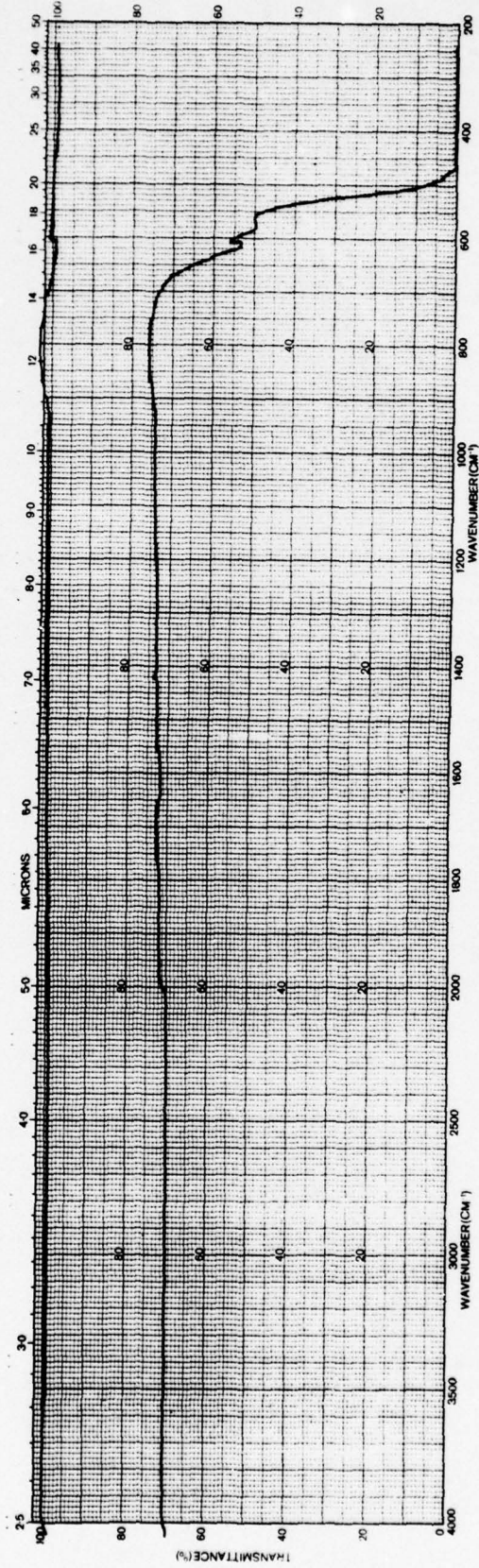

Figure 3. Infrared Transmittance, Plate C, Pos. 2M,
 $t = 0.261$ in.

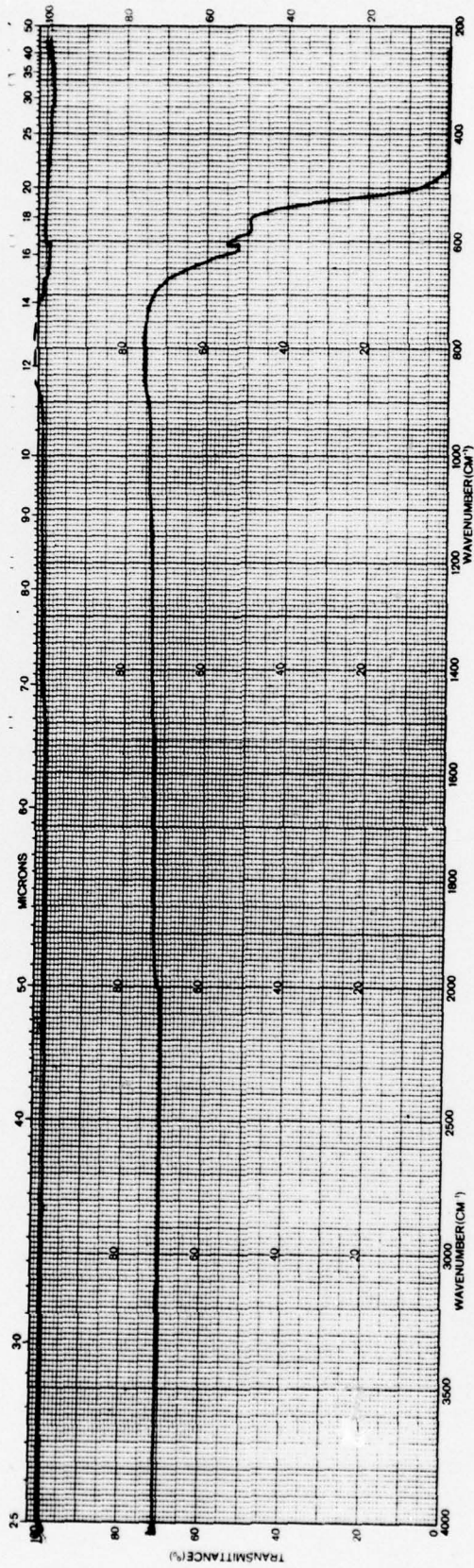

Figure 4. Infrared Transmittance, Plate D, Pos. 28M,
 $t = 0.278$ in.

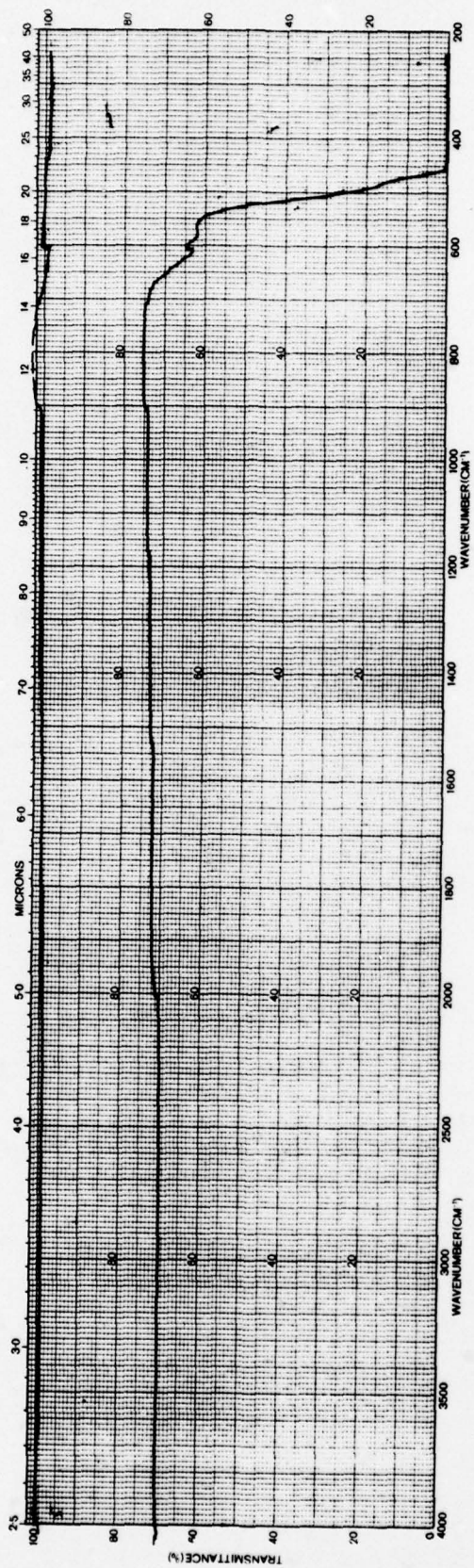

Figure 5. Infrared Transmittance, Plate D, Pos. 52M,
 $t = 0.120$ in.

Table 2

FLEXURAL STRENGTH

(4-point loading)

TOP

<u>Specimen No.</u>	<u>Strength</u> <u>(X 10³ psi)</u>
1	8.5
2	8.8
3	11.9
4	9.6
5	10.0
6	7.4
7	11.5
8	10.9
9	7.3
10	8.8
	<hr/>
	Avg 9.5 ± 1.6

BOTTOM

1	8.8
2	9.3
3	10.2
4	10.0
5	8.7
6	7.7
7	10.0
8	8.5
9	12.2
10	11.1
	<hr/>
	Avg 9.7 ± 1.3

2.2 Engineering Sample Deposit

2.2.1 Sample requirements

This program requires that 12 chemical vapor deposited zinc selenide blanks be fabricated and tested. The blanks shall be fabricated to 75 mm diameter by 9.7 mm thick. Dimensional tolerances on all samples shall be $\begin{matrix} +2 \\ -0 \end{matrix}$ mm. The blanks will be tested to meet the following specifications:

- a) Transmission. The uncoated transmission of the blanks shall be greater than 58% over the wavelength region 8 to 13 micrometers at normal incidence. Over the wavelength region 0.6 to 1.1 micrometers the transmittance shall be greater than 43%.
- b) Absorption The absorption over the 8-12 micrometer region shall be less than 0.01 per centimeter at 10.6 μm .
- c) Parallelism. The provided blank shall have maximum allowable wedge of 10 minutes.
- d) Strain. The distribution of permanent strain shall be symmetrical and the birefringence resulting from permanent strain shall not produce more than 10 nanometers relative retardation or path difference per centimeter of a transmitted narrow band light source.
- e) Chips and fractures. A vented fracture exceeding 10 mm in length or aiming at the center of the blank will be rejected. Blanks having pressure or fire cracks deeper than 1 mm will be rejected. Other surface irregularities, pits, or cracks will not extend into an envelope defined by the minimum allowable dimensions.
- f) Scatter. The angular spread of a focused spot on a blank will not increase by more than 15 percent over the angular spread of the same spot without the sample in the beam over the wavelength region 0.6 to 1.2 micrometers. The angular spread over the wavelength region 8 to 12 micrometers will be less than 2 percent.

g) Identification and marking. Each blank will be individually bagged and the bag marked in accordance with MIL-STD-130 with the type of material, size, individual run number identification, and manufacturer's name or code symbol.

2.2.2 Deposition

A 327-hour zinc selenide deposit was conducted to yield the required engineering samples. The deposit was made using the 17 by 9 by 60 inch mandrel, similar to the Pre-Engineering deposit. Deposition conditions for this deposit are presented in Table 1.

Figure 6 displays the thickness profile of one of the plates from the Engineering deposit. Samples were located from the top of plate C and fabricated into the specified blank dimensions. The optical quality of the zinc selenide was good, however, a portion of the latter deposited material contained a visibly scattering layer. The layer did not interfere with locating the engineering samples and was outside the required thickness to produce a zinc selenide blank.

2.2.3 Tests on engineering samples

All twelve (12) engineering samples were tested and found to meet: dimensional requirements, specified chip and fracture criteria, and spectral transmittance requirements in the infrared and the visible. Typical transmittance curves are presented in Figures 7 and 8 for the infrared and visible spectra, respectively.

Engineering samples No. ENG-11 and ENG-12 were tested for absorption coefficient at 10.6 μm . Each sample was measured in three locations and the average absorption coefficient (including surface absorption) was determined. Absorption coefficients of $1.98 \times 10^{-3} \text{ cm}^{-1}$ and $1.68 \times 10^{-3} \text{ cm}^{-1}$ were measured for samples No. ENG-11 and ENG-12, respectively. The thickness of these two samples was 1.08 cm.

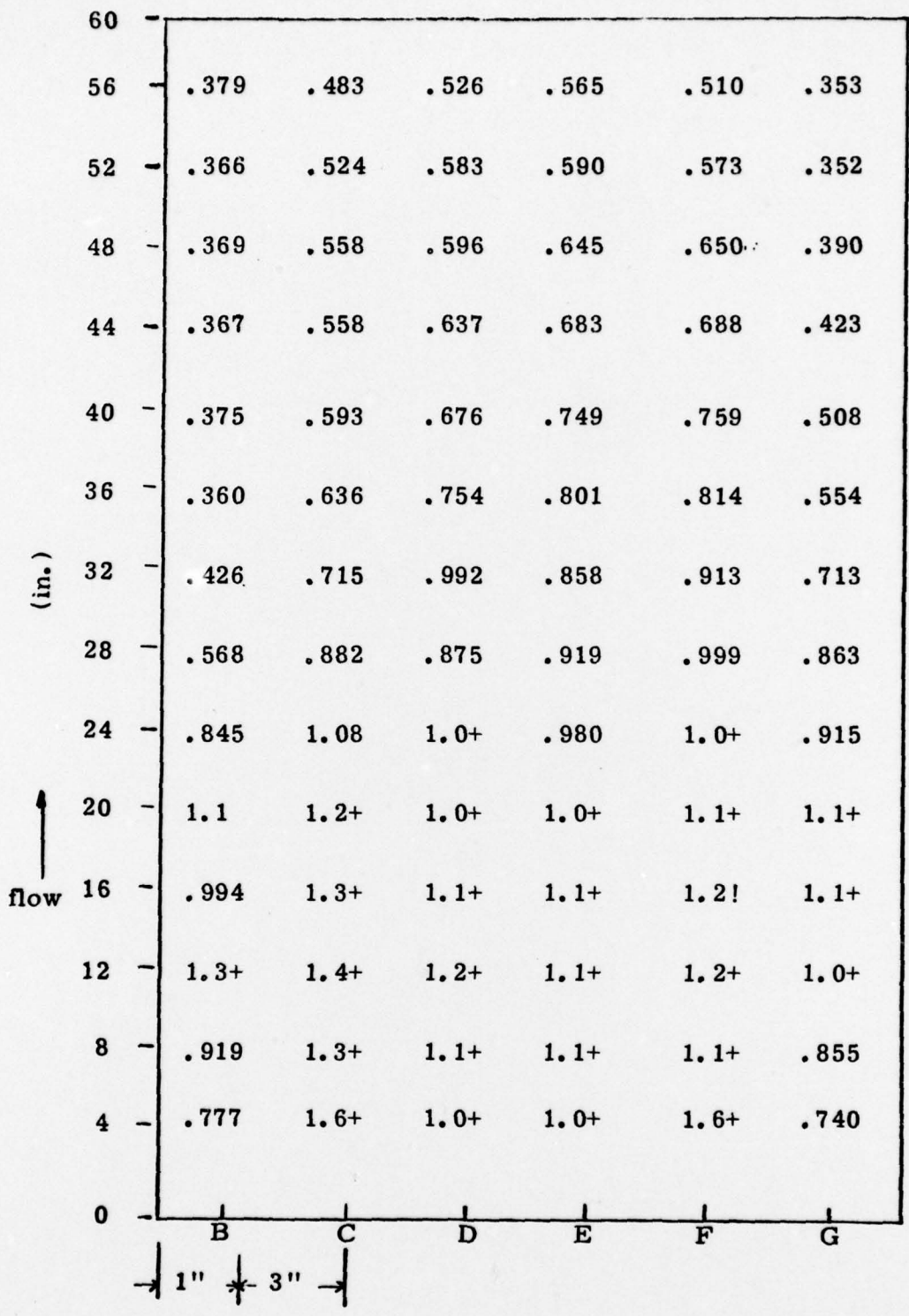

Figure 6. Thickness Profile, Plate A, Engineering Deposit

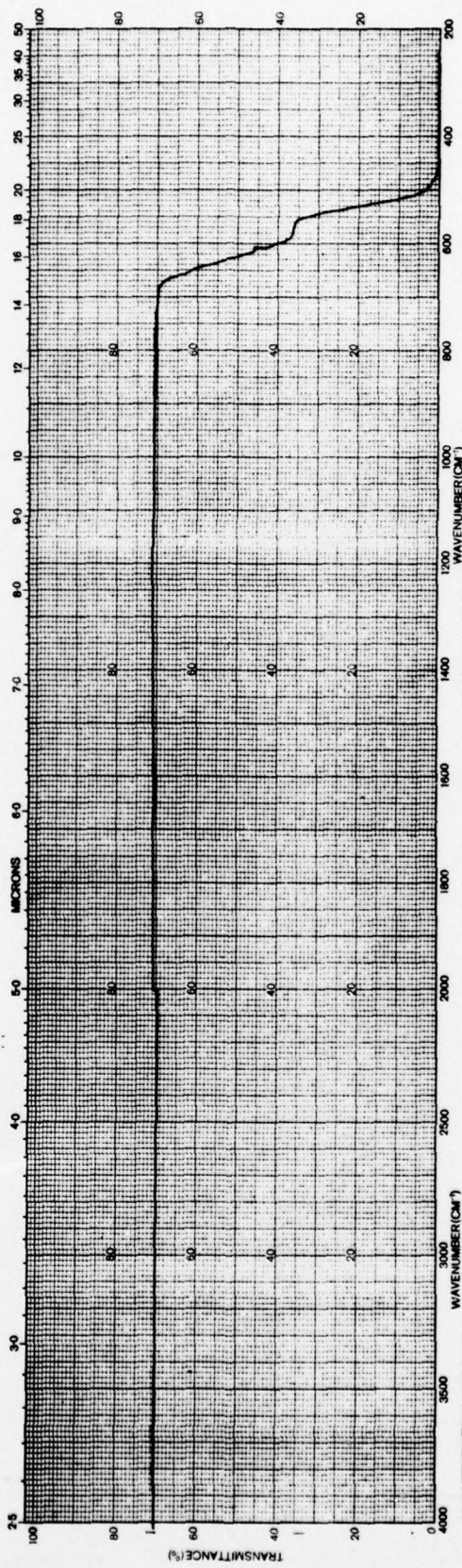

Figure 7. Infrared Transmittance of Sample ENG-1.

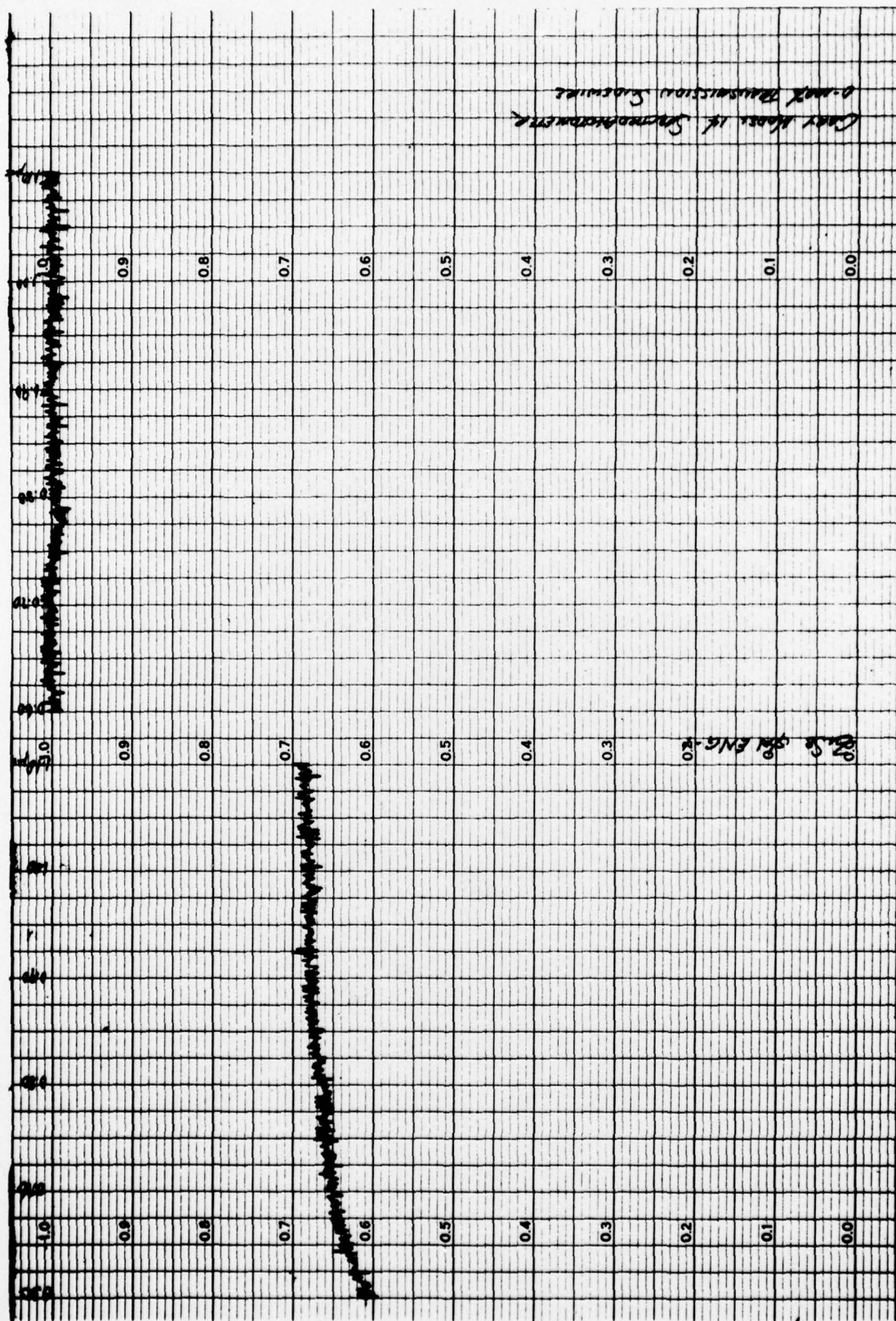

Figure 8. Transmittance From 0.6 to 1.1 μm of Sample ENG-1.

All twelve zinc selenide blanks tested for strain showed no relative retardation. Localized birefringence is present in individual crystallites, however, no larger order birefringence was discernible.

Table 3 presents the image spoiling data from samples No. ENG-11 and ENG-12. These results are discussed in Section 3.0 - MEETINGS.

2.3 Substrate Modifications

An alternative method of depositing zinc selenide on a curved substrate rather than on a flat has been recently investigated under this program. In this method, the zinc selenide is deposited to near net shape on one side. Figure 9 displays the concept of the curved mandrel. This method of producing lenses will shorten the length of the required deposit, resulting in a direct cost reduction, and will reduce the fabrication cost of the finished lens. This deposition technique is being implemented in the confirmatory and pilot runs. New curved substrates have been fabricated for use in the confirmatory deposit.

3.0 MEETINGS

A meeting was held on 26 January 1979 at the Research Division with Raytheon personnel involved in the program and Mr. D. Helm and Mr. A. Efke, both of Fort Belvoir. The engineering sample test results and program requirements were discussed at this time. One area of concern was the failure of sample No. ENG-12 to meet the required image spoiling criteria (allowable image growth of 2%; 3.1% tested for sample ENG-12). The interferograms for this sample were examined, revealing a surface figure that does not meet the polishing specifications required for testing. It appears that this is the cause for the excessive image broadening seen in this sample. Mr. Efke has consented to further test this sample on his image spoiling equipment to determine if the problem is in the material quality or sample preparation.

TABLE 3

IMAGE SPOILING DATA

<u>Sample No.</u>	<u>Image Width (μrad)</u>		<u>%</u>	<u>Spectra</u>
	<u>No. Sample</u>	<u>With Sample</u>	<u>Image Growth</u>	
ENG-11	155.7	158.6	1.8	8-12 μ m
ENG-12	155.7	160.5	3.1	
<hr/>				
ENG-11	16.8	17.9	6.5	0.6-1.1 μ m
ENG-12	16.8	17.9	6.5	

PBN - 76 - 506

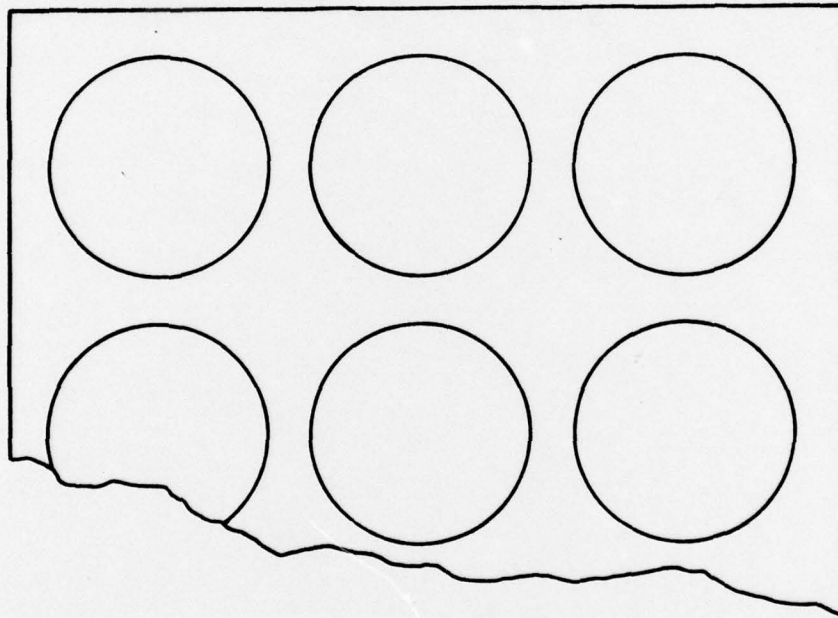
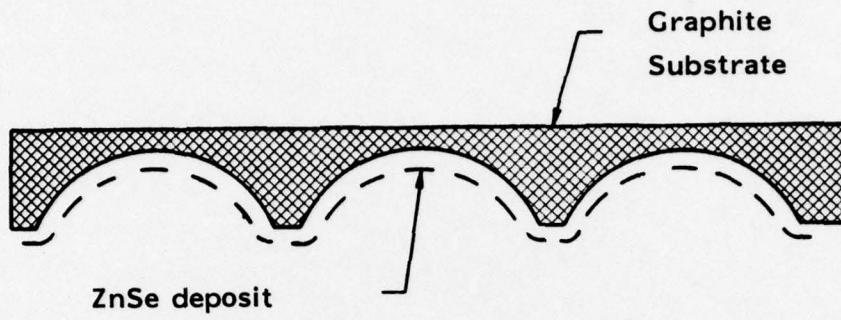

Figure 9. Curved Mandrel.

The twelve (12) engineering samples and the Engineering Test Report were submitted at this meeting.

4.0 CONCLUSIONS

The evaporator system has performed successfully in two full-scale deposits producing zinc selenide of the same quality of that made with the reservoir system.

5.0 PROGRAM FOR THE NEXT INTERVAL

The confirmatory deposit will be set up and deposited during the next reporting period. The zinc selenide from this deposit will be cut and fabricated into the required test blanks. Testing and property evaluation on these samples will be conducted.

6.0 PUBLICATIONS

There were no publications during this reporting period.

7.0 PERSONNEL

The following is the worked manhours for key personnel on this program:

<u>Name</u>	<u>Mahours During Report Period</u>
Mr. R. Donadio	21.0
Mr. T. Varitimos	24.0
Research Technicians	268.0
Publications	<u>18.5</u>
Total	331.5

DISTRIBUTION LIST

Commander
Defense Documentation Center
ATTN: DDC-TCA (Quantity 12)
Cameron Station, Building 5
Alexandria, VA 22314

HQDA (DAMA-WSA)
ATTN: LTC Waddel
Washington, DC 20310

HQDA
ATTN: DAMA-CSC-ST
Room 3D43
Pentagon
Washington, DC 20310

Commander
Air Research & Development Command
ATTN: RDTCT
Andrews AFB
Washington, DC

Development and Readiness Command
ATTN: DRCMT (Mr. Fred Michel)
5001 Eisenhower Avenue
Alexandria, VA 22333

Commander
US Army Materiel Development &
Readiness Command
ATTN: DRCQA
5001 Eisenhower Avenue
Alexandria, VA 22333

Commandant
US Army Aviation School
ATTN: ATZQ-D-MA (O. Heath)
Fort Rucker, AL 36360

Director
US Army Production
Equipment Agency
ATTN: Mr. C. McBurney
Rock Island Arsenal
Rock Island, IL 61299

Commander
US Army Missile Command
ATTN: DRSMI-RR (Dr. J. P. Hallows)
Redstone Arsenal, AL 35809

Commander
US Army Tank-Automotive Command
ATTN: DRSTA-RW-L
Warren, MI 48090

Commander
US Army Missile Command
ATTN: DRSMI-RE (Mr. Pittman)
Redstone Arsenal, AL 35809

Commander
US Army Tank-Automotive Command
ATTN: DRSTA-RHP (Dr. J. Parks)
Warren, MI 48090

Commander
US Army Missile Command
Redstone Scientific Info. Center
ATTN: Chief, Document Section
Redstone Arsenal, AL 35809

US Army Missile Command
ATTN: DRSMI-RGP (Mr. Victor Ruwe)
Redstone Arsenal, AL 35809

Commander
US Army Materials and Mechanics
Research Center
ATTN: DRXMR-M (N.H. Fahey)
Watertown, MA 02172

Director
US Army Industrial Base Engineering
Activity
ATTN: DRXIB-MT
Rock Island, IL 61299

Commander
Picatinny Arsenal
ATTN: SARPA-TS-S No. 59
Dover, NJ 07801

DISTRIBUTION LIST

Commander
US Naval Air Systems Command
ATTN: AIR 335 (Mr. E. Cosgrove)
Washington, DC 20361

Commander
Department of the Navy, ELEX 05143A
ATTN: A. H. Young
Electronics System Command
Washington, DC 20360

Chief
Naval Ship Systems Command
Department of the Navy
ATTN: Code 681A2b (Mr. L. Gumina)
Room 3329
Washington, DC

Commander
US Navy Weapons Center
Michelson Lab
ATTN: Code 6018 (H. E. Barnett)
China Lake, CA 93555

Director
Naval Research Laboratory
ATTN: Code 2627
Washington, DC 20375

Commander
US Naval Air Development Center
ATTN: CODE 202 (Mr. T. J. Shopple)
Johnsville, Warminister, PA 18974

Commander
Naval Ocean Systems Center
Code 9254 (ATTN: Mr. Richard Gamble)
San Diego, CA 92152

Commander
US Air Force Materials Laboratory
ATTN: AFML/CPO (Mr. D. Fisher)
Wright Patterson AFB
Dayton, OH 45433

NASA Scientific & Tech
Information Facility
P.O. Box 8757
Baltimore/Washington, Int'l Airport

Bell & Howell Corporation
ATTN: Mr. George R. McGee
7100 McCormick Road
Chicago, IL 60645

Director
Optical Sciences Center
University of Arizona
Tucson, AZ 85721

Dr. Arthur Cox
1116 South Aldine Avenue
Park Ridge, IL 60068

Farrand Optical Co. Inc.
ATTN: Mr. Martin Shenker
117 Wall Street
Valhalla, NY 10595

Grumman Aerospace Corp.
Research Dept. and Advanced
Development Dept.
Bethpage, NY 11714

Hughes Aircraft Corporation
ATTN: Mr. Phil Henning
P.O. Box 90515
Los Angeles, CA 90009

Martin Marietta Corporation
ATTN: Mr. James Ohmart (MP276)
P.O. Box 5837
Orlando, FL 32805

Melles Griot
1770 Kettering Street
Irvine, CA 92714

DISTRIBUTION LIST

Northrop Corporation
Electro-Mechanical Division
ATTN: Mr. Paul Holderman
500 East Orangethorpe Avenue
Anaheim, CA 92801

Optic-Electronic Corporation
ATTN: Mr. Bryan Coon
11477 Page Mill Road
Dallas, TX 75243

Optical Coating Laboratory, Inc.
2789 Giffen Avenue
P.O. Box 1599
Santa Rosa, CA 95402

Optical Systems & Technology Inc.
ATTN: Mr. Harry W. A. Vandermeer
4 Alfred Circle
Bedford, MA 01730

Rockwell International
Corporation Science Center
Thousand Oaks, CA

Space Optics Research Labs
ATTN: Mr. C. A. Pipan
7 Stuart Road
Chelmsford, MA 01824

Tinsley Laboratories Inc.
2448 Sixth Street
Berkeley, CA 94710

Director
US Army Night Vision & Electro-Optics
Laboratory (Quantity 5)
ATTN: DELNV-SI (Mr. D. Helm)
Fort Belvoir, VA 22060