

AD-A069 374

CONSTRUCTION ENGINEERING RESEARCH LAB (ARMY) CHAMPAIGN IL F/G 13/2
EVALUATION OF ALTERNATIVES FOR RESTORING THE SOUTH BOILER HOUSE--ETC(U)
MAY 79 B A DONAHUE, S A HATHAWAY, G SCHANCHE

UNCLASSIFIED

CERL-TR-N-66

NL

1 OF 1

AD
A069374



END
DATE
FILMED

7-79
DDC

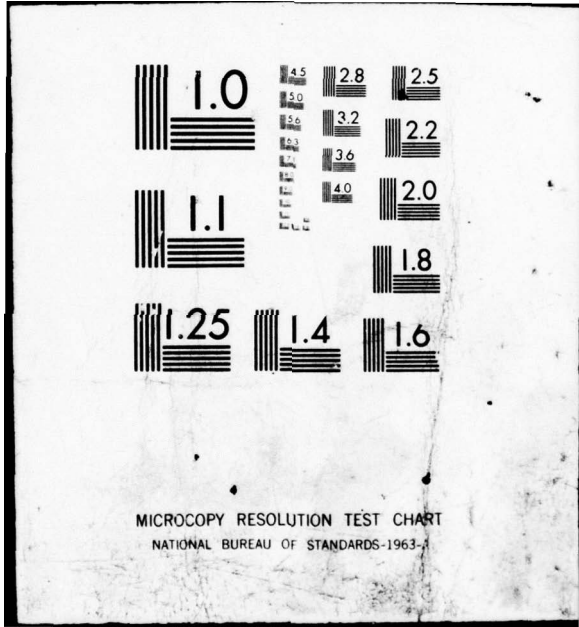

MICROCOPY RESOLUTION TEST CHART
NATIONAL BUREAU OF STANDARDS-1963-A

construction
engineering
research
laboratory



United States Army
Corps of Engineers
... Serving the Army
... Serving the Nation

TECHNICAL REPORT N-66
May 1979

A Systematic Study of Viable Strategies for the Control of
Sulfur Oxide Emissions from Army-Size Boilers

EVALUATION OF ALTERNATIVES FOR RESTORING
THE SOUTH BOILER HOUSE AT JOLIET AAP
TO HIGH-SULFUR-COAL BURNING CAPABILITY

ADA 069374

DDC FILE COPY

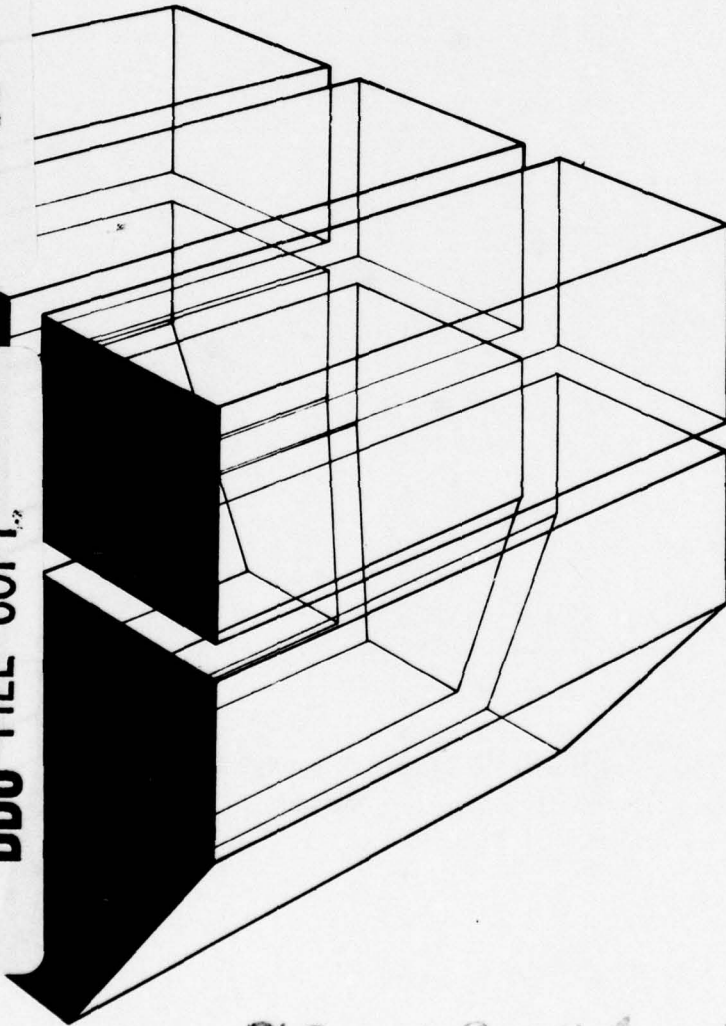

P.S. LEVEL #

by
B. A. Donahue
S. A. Hathaway
G. Schanche
S. R. Struss

DDC
RECEIVED
JUN 5 1979
A



79 06 04 108

Approved for public release; distribution unlimited.

The contents of this report are not to be used for advertising, publication, or promotional purposes. Citation of trade names does not constitute an official indorsement or approval of the use of such commercial products. The findings of this report are not to be construed as an official Department of the Army position, unless so designated by other authorized documents.

***DESTROY THIS REPORT WHEN IT IS NO LONGER NEEDED
DO NOT RETURN IT TO THE ORIGINATOR***

REPORT DOCUMENTATION PAGE		READ INSTRUCTIONS BEFORE COMPLETING FORM
1. REPORT NUMBER 14 CERL-TR-N-66	2. GOVT ACCESSION NO.	3. RECIPIENT'S CATALOG NUMBER
4. TITLE (and Subtitle) 6 EVALUATION OF ALTERNATIVES FOR RESTORING THE SOUTH BOILER HOUSE AT JOLIET AAP TO HIGH-SULFUR-COAL BURNING CAPABILITY.		5. TYPE OF REPORT & PERIOD COVERED 9 FINAL rept.
7. AUTHOR(s) 10 A. Donahue, S./Struss S. A. Hathaway G. Schanche		6. PERFORMING ORG. REPORT NUMBER
9. PERFORMING ORGANIZATION NAME AND ADDRESS U.S. ARMY CONSTRUCTION ENGINEERING RESEARCH LABORATORY P.O. Box 4005, Champaign, IL 61820		8. CONTRACT OR GRANT NUMBER(s) 2182040 08-1704 P691000 S11-205
11. CONTROLLING OFFICE NAME AND ADDRESS		10. PROGRAM ELEMENT, PROJECT, TASK AREA & WORK UNIT NUMBERS
	11	12. REPORT DATE May 1979
		13. NUMBER OF PAGES 40
14. MONITORING AGENCY NAME & ADDRESS (if different from Controlling Office) 12 43 p.		15. SECURITY CLASS. (of this report) Unclassified
		15a. DECLASSIFICATION/DOWNGRADING SCHEDULE
16. DISTRIBUTION STATEMENT (of this Report) Approved for public release; distribution unlimited.		
17. DISTRIBUTION STATEMENT (of the abstract entered in Block 20, if different from Report)		
18. SUPPLEMENTARY NOTES Copies are obtainable from National Technical Information Service Springfield, VA 22151		
19. KEY WORDS (Continue on reverse side if necessary and identify by block number) Joliet Army Ammunition Plant, IL boilers coal air pollution control		
20. ABSTRACT (Continue on reverse side if necessary and identify by block number) This report evaluates alternatives for restoring the south boiler house at the Joliet Army Ammunition Plant to burn high-sulfur coal in an environmentally acceptable manner. The boiler house was examined to assess its coal handling and burning capability. Various flue-gas cleaning devices were then field evaluated to determine their potential application at the Joliet plant for particulate removal and for flue-gas desulfurization.		

Block 20 continued.

After comparing the economics of the various alternative systems, it was determined that the boiler house can be repaired and upgraded to handle and burn coal, that the baghouse in the 1980 Military Construction-Army program will be satisfactory for particulate removal, and that limestone flue-gas desulfurization, the ash and slurry being disposed of in a lined pond is the apparent most cost-effective long-term solution.

UNCLASSIFIED

FOREWORD

This investigation was performed by the members of the Environmental (EN) and Energy and Habitability (EH) Divisions, U.S. Army Construction Engineering Research Laboratory (CERL) for the U.S. Army Armament Material Readiness Command under appropriation 2182040 08-1704 P691000 S11-205; reimbursable order; work unit title, "A Systematic Study of Viable Strategies for the Control of Sulfur Oxide Emissions from Army-Size Boilers." Mr. Tom Wash is the Armament Material Readiness Command technical monitor.

Mr. Bernard A. Donahue was the CERL Principal Investigator. Administrative support and counsel were provided by Dr. R. K. Jain, Chief of EN, Mr. R. G. Donaghy, Chief of EH, and Mr. Joseph Matherly of EN.

Appreciation is extended to Mr. Robert Ridgway, Chief Engineer at JAAP, for his invaluable assistance throughout this investigation.

COL J. E. Hays is Commander and Director of CERL, and Dr. L. R. Shaffer is Technical Director.

Accession For	
NTIS G.M&I	<input checked="" type="checkbox"/>
DDC TAB	<input type="checkbox"/>
Unannounced	<input type="checkbox"/>
Justification	
By _____	
Distribution/	
Availability Codes	
Dist	Avail and/or special
A	

379 06 04 108

CONTENTS

	<u>Page</u>
DD FORM 1473	1
FOREWORD	3
LIST OF TABLES AND FIGURES	6
1 INTRODUCTION.....	7
Background	
Objective	
Approach	
2 PROBABLE COAL SUPPLY.....	9
Probable Coal Resources	
Characteristics of Illinois Basin Coals	
3 APPLICATION OF AIR POLLUTANT EMISSION FACTORS.....	11
4 REQUIRED POLLUTANT REMOVAL EFFICIENCIES.....	13
Air Pollutant Emission Limitations	
Required Removal Efficiencies	
5 RESTORATION OF SBH TO COAL-BURNING OPERATION.....	14
General	
Coal Delivery	
Open Coal Storage	
Bunkers	
Feeders	
Coal Burners and Combustion Controls	
Furnaces	
Draft System	
Steam Distribution	
Ash Removal	
Water Treatment	
Utilities	
Cost Estimate of Restoration	
6 TECHNOLOGICAL AND ECONOMIC REVIEW OF APPROPRIATE FLUE-GAS DESULFURIZATION SYSTEMS.....	19
General	
Limestone Slurry Scrubbing	
Magnesia Slurry Scrubbing	
Sodium Solution Scrubbing	
Double Alkali Scrubbing	

7	BY-PRODUCT USE AND DISPOSAL.....	27
	General	
	Bottom Ash Disposal	
	Fly Ash Disposal	
	FGD Sludge Disposal	
	FGD By-Product Disposal	
8	USE OF COAL-DERIVED FUEL AT JAAP.....	31
	General	
	Process Description	
	Application of the KT Process at JAAP	
	Cost Estimate for the KT Process	
9	COMPARATIVE LIFE-CYCLE ANALYSIS.....	34
	General	
	Power Plant and Particulate Matter Removal Costs	
	FGD System Costs	
	Waste Disposal Costs	
10	CONCLUSIONS AND RECOMMENDATIONS.....	36
	APPENDIX: Economic Analyses	37
	DISTRIBUTION	

TABLES

<u>Number</u>		<u>Page</u>
1	Characteristics of Probable Supply Coals (PSCs)	10
2	Predicted Full-Load Unabated Pollutant Emissions From the SBH Boiler	12
3	Estimated Investment Cost of SBH Restoration (Three Boilers)	18
4	Annual Consumptions and Costs (10^3 dollars in FY81) of FGD Systems Analyzed	20
5	O&M Cost Comparison Summary (10^3 \$)	21
6	Cost Summary of the FGD Systems Analyzed (FY81 Dollars)	21
7	Capital Costs for By-Product Disposal Alternatives	28
8	Operating and Maintenance Costs for By-Product Disposal Alternatives	29
9	Composition of Coal-Derived Gas from the Koppers-Totzek Process	32
10	Estimated Investment Cost for Constructing a Coal Gasification Plant and Restoring the SBH to Burn Coal-Derived Gas	33
11	Cost Summary	35
A1	Data for Economic Analyses	38

FIGURES

1	Limestone Slurry Scrubbing System	22
2	Magnesia Slurry Scrubbing System	24
3	Sodium Solution Slurry Scrubbing with Regeneration	25
4	Double Alkali Scrubbing System	26

EVALUATION OF ALTERNATIVES FOR RESTORING
THE SOUTH BOILER HOUSE AT JOLIET AAP
TO HIGH-SULFUR-COAL BURNING CAPABILITY

1 INTRODUCTION

Background

Joliet Army Ammunition Plant (JAAP) is a U.S. Army Armament Materiel Readiness Command government-owned, contractor-operated (Uniroyal, Inc.) facility located in Will County, IL, approximately 40 miles southwest of the Chicago central business district. It is currently in standby status.

JAAP has two "carbon copy" main boiler plants, each tied into the main steam distribution loop. The South Boiler House (SBH) is located 1 mile south of the North Boiler House (NBH) and contains three 1941-vintage, two-drum, bent-tube boilers manufactured by Combustion Engineering, each with a rated steam production capacity of 125,000 lb/hr at 375 psig (maximum) working pressure, superheated to 490^oF (254.4^oC). Each boiler is equipped with four horizontally fired turbulent burners and was designed to burn pulverized Illinois Basin bituminous coal. Single-stage dry mechanical dust collectors are installed between the air preheater and the stack for flue-gas particulate removal.

The SBH was mothballed in 1974 when the NBH was converted to natural gas and assumed the total JAAP steam demand. The increasing cost and scarcity of natural gas have made it desirable to return to coal as a primary fuel at JAAP. The conversion would likely follow a sequential strategy in which the SBH would first be restored to operation burning coal. It would then supply the full steam demand while the NBH is reconverted to burn coal.

Objective

The objective of this investigation was to determine the most cost-effective means of restoring the SBH by FY81 to burn high-sulfur coal as a primary fuel at design capacity, in a manner compatible with environmental standards.

Approach

This investigation followed eight steps:

1. Primary source data were reviewed to determine the most probable long-term coal supplies (probable-supply coal, or PSC) to JAAP (Chapter 2).
2. Standard emission factors were applied to determine anticipated unabated air pollutant emissions from the SBH when burning PSCs (Chapter 2).
3. Current laws governing air pollutant emissions in the Chicago metropolitan area were reviewed and compared to anticipated SBH emissions to determine the pollutant removal efficiencies required for environmentally compatible operations (Chapter 4).
4. A technical and economic assessment was made of restoring the SBH's capability for burning pulverized coal based on the previously determined characteristics of the PSCs (Chapter 5).
5. The current technology was reviewed to identify the technologies potentially applicable to the removal of anticipated air pollutants at the required efficiencies (Chapter 6).
6. By-product usage and disposal alternatives were reviewed (Chapter 7).
7. Current technology was reviewed to identify the technologies potentially applicable to producing and burning a clean coal-derived fuel at the SBH. Also included was a technical-economic assessment of converting the SBH to the use of coal-derived fuel (Chapter 8).
8. Life-cycle economic analyses were conducted, comparing all coal-use technologies found to be applicable. These analyses were based on the assumptions that design and construction would take place in FY80, that startup would occur in FY81, and that the plant would have a 15-year functional life. They were carried out to determine the most cost-effective system for the environmentally compatible use of coal at the SBH (Chapter 9).

2 PROBABLE COAL SUPPLY

Probable Coal Resources

A review of the coal production and supply trends for northern Illinois industrial consumers indicates that the PSC for JAAP is bituminous coal from the Illinois Basin (located in southern Illinois and Indiana).¹ Large, well-developed coal resources are found in this nearby region. It is expected that the coal they yield would have a price advantage over more distant coals, such as low-sulfur western coals. The Illinois Basin contains 20 percent of the nation's known coal reserves, ensuring a potential long-term supply. Southern Illinois and Indiana bituminous coals are close to the specified SBH design coal in quality, and their use would follow pre-established supply patterns at JAAP, where "local" coals (e.g., Peabody, Republic, Bell, and Zoller) have been used previously.

It is unlikely that low-sulfur eastern or western coals would be economically usable at JAAP because of the long transport distance and the uncertainty about their future availability. At present, there is growing competition at the national level for low-sulfur western coals. However, the draft National Energy Plan proposes mandatory flue-gas scrubbing regardless of the type of coal burned in direct-combustion systems. If adopted, that plan could encourage the use of more easily and economically obtainable local coals in preference to imported low-sulfur coals. Moreover, in response to a recent decision by Commonwealth Edison to use low-sulfur western coal instead of Illinois coal in a large Illinois power plant, the governor of Illinois has stated his intent to ensure maximum use of the state's coal resources and thereby to maintain economic levels in its mining sector. How he will do so is currently uncertain; nevertheless, it appears that political factors will act strongly in the near future to limit the importation of coal to Illinois users.

Characteristics of Illinois Basin Coals

Table 1 gives the averaged results of analyses of bituminous coals mined in southern Illinois and Indiana. These data indicate that the PSC to JAAP will have a calorific value between 10,425 Btu/lb and 12,500 Btu/lb, a sulfur content by weight between 1.2 percent and 8.0 percent, and an ash content by weight between 6.3 percent and 12.2 percent. These data may be compared to the design fuel for the SBH which is "not less favorable" than 12,000 Btu/lb and 11 percent ash. Design fuel specifications for the SBH do not mention sulfur content.

¹ Keystone Coal Industry Manual (McGraw-Hill, 1976).

Table 1
 Characteristics of Probable Supply Coals (PSCs)

Coal	Calorific Value (Btu/lb)	Sulfur (Wt. %)	Ash (Wt. %)
<u>Average Analysis: Illinois Bituminous Coal</u>			
Rock Island No. 1	10,800	4.5	8.5
Murphysboro	12,500(MAX)	8.0(MAX)	8.0
Dekoven and Davis	12,475	3.8	9.8
Colchester No. 2	11,120	2.8	7.5
Sumnum	11,050	3.5	8.0
Harrisburg-Springfield No. 5	11,370	3.6	10.2
Herrin No. 6	11,060	2.9	10.0
Danville No. 7	10,425(MIN)	3.3	11.8
<u>Average Analysis: Indiana Bituminous Coal</u>			
Danville No. 7	10,900	2.1	12.2(MAX)
Hymera No. 6	11,050	2.6	9.9
Springfield No. 5	11,590	3.3	9.3
Survant No. 4	11,160	1.2(MIN)	8.4
Seelyville No. 3	11,080	3.1	11.2
Minshall	11,130	3.2	11.1
Upper Block	11,500	2.7	6.3(MIN)
Lower Block	11,560	1.7	7.5

3 APPLICATION OF AIR POLLUTANT EMISSION FACTORS

Air pollutant emission factors published by the U.S. Environmental Protection Agency (USEPA) were applied in determining the expected unabated emission levels from the SBH when burning any of the PSCs given in Table 1.² The particular pollutants assessed (and their corresponding emission factors, given in parentheses) were particulates (16), sulfur oxides (38), carbon monoxide (1), hydrocarbons (0.3), nitrogen oxides (18), and aldehydes (0.005).

Applying the emission factors produces data on the expected emissions in units of pounds of pollution per ton of coal burned. Since emission standards are written in terms of pounds of pollutant per MBTU of fuel input, it was necessary first to determine for each of the PSCs the mass firing rate required to operate a given SBH boiler at its nominal rated steam capacity. Under design conditions, burning coal with a calorific value of 12,000 Btu/lb, the coal must be fed to the burner at a rate of 14,800 lb/hr. The design heat input to the furnace in the form of fuel is hence 177.60 MBtu/hr for a full-load superheated steam output of 125,000 lb/hr per boiler.

Once the firing rates of the PSCs were determined, the emission factors were applied to yield the data on expected emissions given in Table 2. Based on these data, particulates may be produced at a rate as high as 9.06 lb/MBtu and sulfur oxide emissions may be as great as 12.16 lb/MBtu.

Also shown in Table 2 are the coal input rate to the burner for a given SBH boiler when burning any PSC. A maximum rate of 17,036 lb/hr is shown, which is barely within the design tolerances of the existing feeding and firing systems at the SBH.

² Compilation of Air Pollutant Emission Factors, Report AP-42 (USEPA, 1975).

Table 2
 Predicted Full-Load Unabated Pollutant Emissions from the SBH Boiler

Coal	Coal Input To Burners (lb/hr)*	Predicted Emissions (lb/MBtu input)					Aldehydes
		Particulates	Sulfur Oxides	Carbon Monoxide	Nitrogen Oxides		
Illinois							
Rock Island No. 1	16,444	6.30	7.92	0.05	0.83		T**
Murphysboro	14,208(MIN)	5.12	12.16(MAX)	0.04	0.72		T
Dekoven and Davis	14,236	6.28	5.79	0.04	0.72		T
Colchester No. 2	15,971	5.40	4.78	0.04	0.81		T
Sumnum	16,072	5.79	6.02	0.05	0.81		T
Harrisburg-Springfield No. 5	15,620	7.18	6.02	0.04	0.79		T
Herrin No. 6	16,058	7.23	4.98	0.05	0.81		T
Danville No. 7	17,036(MAX)	9.06(MAX)	6.01	0.05	0.86		T
Indiana							
Danville No. 7	16,294	8.95	3.66	0.05	0.83		T
Hymera No. 6	16,072	7.17	4.47	0.05	0.81		T
Springfield No. 5	15,324	6.42	5.41	0.04	0.78		T
Survant No. 4	15,914	6.02	2.04(MIN)	0.04	0.81		T
Seelyville No. 3	16,029	8.09	5.32	0.05	0.81		T
Minshall	15,957	7.98	5.46	0.04	0.81		T
Upper Block	15,443	4.38(MIN)	4.46	0.04	0.78		T
Lower Block	15,363	5.19	2.79	0.04	0.78		T
STATE LIMITATIONS		0.10	1.80	(200 PPM)	0.90		***

* DESIGN BASIS = 14,800 lb/hr.
 ** T = LESS THAN 0.00025 lb/MBtu.
 *** No state regulation currently applies.

4 REQUIRED POLLUTANT REMOVAL EFFICIENCIES

Air Pollutant Emission Limitations

Illinois law applying to existing fuel combustion emission sources using solid fuel exclusively in the Chicago metropolitan area³ places the following limits on air pollutant emissions: particulates are not to exceed 0.1 lb/MBtu in any 1-hour period. Sulfur oxides are not to exceed 1.8 lb/MBtu in any 1-hour period, and carbon monoxide is not to exceed 200 ppm in the flue gas at 50 percent excess air. The prevailing 0.9 lb/MBtu emission limit for nitrogen oxides appears to be above the calculated unabated nitrogen oxide emissions previously calculated and listed in Table 2. Aldehyde emissions from coal-fired boilers in the Chicago area are not addressed by current codes.

Required Removal Efficiencies

By comparing the predicted maximum ("worst-case") emissions of particulates and sulfur oxides (Table 2) with the above limitations, one can calculate the removal efficiency that a given abatement technique must provide if it is to be usable at JAAP. The required removal efficiency for particulates is:

$$100 \times \left(\frac{9.06 - 0.10}{9.06} \right) = 99 \text{ percent} \quad [\text{Eq 1}]$$

The required removal efficiency for sulfur oxides is:

$$100 \times \left(\frac{12.16 - 1.80}{12.16} \right) = 86 \text{ percent} \quad [\text{Eq 2}]$$

This investigation did not consider technology-based carbon monoxide abatement techniques. Rather, it was assumed that by properly controlling and monitoring combustor performance, the level of carbon monoxide in the flue gases could be kept at less than the limit. The predicted nitrogen oxide emissions shown in Table 2 are within the legal limits.

³ Illinois Stationary Sources Standards, Environmental Reporter (October 31, 1975), pp 366:0541 to 366:0554.

5 RESTORATION OF SBH TO COAL-BURNING OPERATION

General

The rehabilitation required to restore the SBH to burn pulverized coal is discussed below in terms of major plant unit operations. Subsequent sections of this report discuss alternative pollution abatement strategies that do not involve in-furnace process controls.

Taking into account the time required for competitive bidding, design, and component acquisition and installation, the first day FY81 (i.e., FY80 Military Construction-Army [MCA] funding) was established as the construction midpoint. Current (FY78) and project-year (FY80) investment costs for restoration were derived by standard cost-estimating procedures.^{4,5} The short-term escalation rates used were: FY78, 8.0 percent; FY79, 8.0 percent; FY80, 8.0 percent; and FY81, 8.0 percent. A geographic factor (for Chicago) of 1.02 and a technological adjustment factor of 1.05 were used. The overall cost hike factor was therefore:

$$1.08 \times 1.08 \times 1.08 \times 1.08 \times 1.02 \times 1.05 = 1.46 \quad [\text{Eq } 3]$$

Coal Delivery

The coal delivery system at the SBH consists of a below-grade delivery hopper under a rail head. All trackage appears to be operable, as evidenced by its intermittent use during railroad car painting. A new car shelter, vibratory-type shaker, heaters, delivery grate, delivery hopper, and transfer conveyor would be required since these items either have deteriorated seriously or have been removed from the site. A water spray should be added to the base of the enclosed elevating conveyor to reduce dusting on the conveyor itself and at the bunker delivery. The elevating conveyor is structurally sound but would require a new belt, hood rebolting in several places, and protective coating. The downspout from the transfer house is operable, but the house itself would require cleaning, painting, replacement of some windows, and safe access from ground level.

The coal analysis room at the receiving area appears to be structurally sound and safe but it would have to be resupplied with analytical equipment (e.g., glassware, a grinder, chemicals, a sieve, etc.) and communications facilities.

⁴ Building Construction Cost Data (R. S. Means Co., 1977).

⁵ Process Plant Engineering Standards (Richardson Engineering Co., 1977).

Open Coal Storage

In the original plant design, a small area immediately northeast of the SBH was available for coal storage and held all coal (diverted from the transfer house) not delivered to the bunker. A 420,000 gal fuel oil tank was installed in the open storage area several years ago.

The current open storage area is too small to hold the 90-day coal supply now required by DOD. Based on the worst case (i.e., full-load SBH operation 24 hr/day with 10,425 Btu/lb coal), an area of approximately 7 acres would be required to store the 55,200-ton, 90-day coal supply. There is enough unused open land south of the SBH that could be developed for environmentally sound 90-day coal storage. An active pile at the original coal storage area would be maintained, requiring relocation of the fuel oil tank; bunkers would be maintained at appropriate levels.

Restoration of open coal storage at the SBH would require an investment in land development (a storage area, berms for runoff control, and access roads) and vehicles (trucks, loaders, and dozers).

Bunkers

Inspection indicated that the bunkers, which have a capacity of approximately 800 tons, are structurally sound but would require new liners to be operable. The existing coal distributor should be rebuilt, particularly in light of its history of frequent clutch burnout. The transfer conveyor appears to be restorable with minor effort (i.e., lubrication). The restoration should provide powered gravity vents, a fire amelioration system, ladder access into the bunkers from the catwalk, and vibratory-type agitators near the hopper outlets.

Feeders

The coal feeding system appears sound. Downspouts, weighing mechanisms, and pneumatic equipment appear restorable with minor rebuilding and component replacement. Restoring the two pulverizers serving each of the three boilers in the SBH would require extensive parts replacement and rebuilding of their drive systems. All coal feeders would have to be rebuilt.

Coal Burners and Combustion Controls

Each boiler at the SBH would require a completely new burner system, combustion control system, and flame safeguard and safety system, including automatic ignitors and safety interlocks, which were not present when the SBH was taken out of service in 1974.

Furnaces

When the SBH was mothballed, the furnaces were sealed, and dehumidification equipment was added to inhibit moisture-related damage to internal surfaces. The superheater tubes were drilled at their bottom bends to drain off moisture. Because the furnaces were sealed, it was not possible to inspect them. Hence, the degree of rehabilitation required could not be determined. However, based on experience, boiler restoration probably will entail, at a minimum, fireside and waterside tube cleaning, some tube replacement, and minor refractory repair. Plant personnel have indicated that the sootblowing equipment is generally in good condition. The superheaters may or may not have to be replaced, depending on the results of an interior inspection.

Draft System

All fans would have to be rebuilt to provide an adequate furnace draft. The degree of fan rehabilitation required should be assessed after the type of coal to be used has been established, its burning properties have been identified, and decisions have been made regarding the method of flue-gas treatment to be used. The mechanical separators and stacks appear to be in working condition.

Steam Distribution

All steam drums appear to be well maintained and operable, although the insulation has deteriorated in spots. The steam lines are said by plant personnel to be in operating condition.

Ash Removal

At present, the means of disposing of bottom ash and fly ash is a nonregenerating wet system which discharges into an ash slurry lagoon created from an existing (south) gravel pit. This investigation recommends discontinuing this practice since the existing gravel pit does not meet current Illinois EPA regulations governing lagoon design. Chapter 7 presents the costs of constructing and operating environmentally acceptable slurry lagoons. A separate study of this problem recommended the addition of a dry fly ash removal system which would include pneumatic (vacuum) transport to a new storage silo, from which the material would be trucked periodically to a landfill.⁶ Bottom ash would be disposed of in a closed recirculating slurry system consisting of dual dehydrating storage bins and a surge tank where the quench water would

⁶ Stack Emission Controls, South Boiler House, Joliet Army Ammunition Plant (P & W Engineers, Chicago, IL, 1975).

be adjusted to the proper pH before it is returned to the ash removal system. The dewatered sludge would be disposed of in a landfill. This investigation concurs with that recommendation.

Water Treatment

The JAAP Chief Engineer indicated that, because of the long steam transport distances, steam condensate is not returned to the SBH. River water is treated and used as boiler feedwater. Existing feedwater treatment facilities at the SBH have deteriorated and are technically obsolete. Restoration of the SBH's coal-burning capability will require completely new feedwater and blowdown treatment facilities.

Utilities

All utility services required for operation of the SBH are available at the site and are in generally good repair.

Cost Estimate of Restoration

Table 3 gives estimated costs of restoring the SBH to operation burning pulverized coal. Current and construction midpoint data are shown, the latter being determined by applying the cost hike factor, 1.46, discussed previously. The costs given are investment, or one-time, costs. This investigation did not ascertain the life-cycle O&M costs associated with the SBH once it has been restored.

The data in Table 3 show that \$7,662,300 would be required in FY80 to restore the SBH to operation using pulverized coal as its fuel. This amount includes a contingency of 25 percent (\$1,532,500) added to the subtotal investment amount of \$6,129,800. Of the latter amount, approximately 83 percent (\$5,073,000) is for new equipment or systems (such as burners, controls, and safety systems; fly and bottom ash removal equipment; and water treatment facilities) to replace existing items which are deteriorated, unsafe, technically obsolete, or environmentally unsound.

Table 3

Estimated Investment Cost of SBH Restoration (Three Boilers)

ITEM*	Current Year (FY78) Cost (\$1,000)	Construction Midpoint (FY81) Cost (\$1,000)
Coal delivery system	180.0	262.8
Coal storage development	50.0	73.0
Bunkers	40.0	58.4
Feeders and pulverizers (6)	250.0	365.0
Burners, controls, and safety system (new)	875.0	1,277.5
Furnaces	90.0	131.4
Draft system	30.0	43.8
Steam distribution	0.0	0.0
Ash removal system (new)	1,100.0	1,606.0
Water treatment system (new)	1,500.0	2,190.0
Utilities	0.0	0.0
Startup, shakedown, operator training	50.0	73.0
Inspection and testing	30.0	43.8
Source testing	3.5	5.1
SUBTOTAL	4,198.5	6,129.8
25% Contingency	1,049.6	1,532.5
FY80 MCA project funding estimate	5,248.1	7,662.3

*See Chapter 5 of the text for general description.

6 TECHNOLOGICAL AND ECONOMIC REVIEW OF APPROPRIATE FLUE-GAS DESULFURIZATION SYSTEMS

General

Each of the flue-gas desulfurization (FGD) processes which the study team deemed applicable to the Army's needs was investigated intensively through literature searches, evaluation of manufacturers' unsolicited proposals for the Joliet plant, and field evaluations of existing plants. Much of the information gathered on costs was contradictory, incomplete, or in many ways not comparable for the purpose of this evaluation. When necessary for comparison purposes, the study team members used their own judgment and adjusted some of the information presented by the manufacturers to a common basis. The unit costs for process inputs and products were adjusted to the values of these units in the Joliet market as supplied by a JAAP representative (Table A1).

Table 4 compares the annual operating costs of the candidate FGD systems showing consumption rates for energy, raw materials, and labor, with credit given for by-products which can be used on-site or marketed. The costs have been adjusted to FY81. Table 5 shows what it will cost in today's dollars to operate the facility over its 15-year life cycle starting in FY81. Table 6 summarizes the capital costs and 15-year present-value annual costs.

An initial step toward flue-gas cleaning at the SBH is the removal of particulate matter from the gas stream. Since a baghouse is currently in the FY80 MCA program and the efficiency of a baghouse depends less on coal variations than does that of electrostatic precipitators (ESPs), it is advantageous to design the system to use a baghouse as the initial gas cleaning step. Only those FGD processes that have been proven in actual field operations and that are adaptable to coal-fired systems the size of JAAP (156 MW equivalent) were evaluated. Of the many FGD processes, only a few have potential application at JAAP: namely, limestone slurry scrubbing, magnesia slurry scrubbing, sodium solution scrubbing, and the double alkali system, which is a combination of the limestone and sodium scrubbing systems. A brief description and a simplified flow diagram of each system are given below.

Limestone Slurry Scrubbing

In the limestone method, shown in Figure 1, stack gas directly from the boiler is washed in a recirculating slurry of limestone and reacted calcium salts in water using a venturi scrubbing system for SO_x removal. The limestone feed is wet ground before being added to the scrubber influent holding tank. Calcium sulfite and sulfate salts are withdrawn and ponded or are dewatered to a filter cake consistency and disposed of

Table 4
Annual Consumption and Costs (10³ Dollars in FY81) of FGD Systems Analyzed

Process Resource	Double-Alkali		Limestone		Sodium		Magnesium Oxide	
	Consumption	Cost	Consumption	Cost	Consumption	Cost	Consumption	Cost
Electrical power (kwh)	8,535,000	460	20,355,000	1,096	10,600,000	571	12,500,000	673
Fuel oil (gal)	--	--	--	--	--	--	2,837,250	1,358
Natural gas (therms)	--	--	--	--	1,132,105	327	--	--
Steam (klb)	12,240	68.4	--	--	586,840	3,281	--	--
Operation Labor (man-years)	12	369	9	275	31	952	15	459
Maintenance (%)	4% of capital	660	4% of capital	628	4% of capital	967	4% of capital	760
Limestone (tons)	50,200	419	55,430	462	--	--	--	--
Other Chemicals (tons)	7,760	822	--	--	3,200	339	347 MgO	92.9
Process Water (kgal.)	70,000	18.2	79,275*	24.6	Soda Ash 2,560,000	793	931,400	288
Waste product (tons)	See Table 7-2	--	See Table 7-2	--	--	--	--	--
By-product (tons)	--	--	--	--	33,200 H ₂ SO ₄	(593)	33,200 H ₂ SO ₄	(593)

* Without dewatering of waste sludge.

Table 5
O&M Cost Comparison Summary (10³\$)

Resource	Double-Alkali		Limestone		Sodium		Magnesium Oxide	
	Yearly Cost	Present Value Life Cycle Cost	Yearly Cost	Present Value Life Cycle Cost	Yearly Cost	Present Value Life Cycle Cost	Yearly Cost	Present Value Life Cycle Cost
Electrical Power	460	5573.82	1096	13280.23	571	6918.81	673	8154.74
Fuel Oil	--	--	--	--	--	--	1358	17624.12
Natural Gas	--	--	--	--	327	4243.81	--	--
Steam	68.4	727.71	--	--	3281	34906.56	--	--
Operation Labor	369	2946.83	275	2196.15	952	7602.67	459	3665.57
Maintenance	660	5270.76	628	5015.21	967	7722.46	760	6069.36
Limestone	419	3346.13	462	3689.53	--	--	--	--
Other Chemicals	822	6564.49	--	--	339	2707.25	92.9	741.90
Process Water	18.2	145.35	24.6	196.46	793	6332.90	288	2299.97
Waste Products	--	--	--	--	--	--	--	--
Salable By-Products	--	--	--	--	(593)	(4735.70)	(593)	(4735.70)
TOTALS	2816.6	24575.09	2485.6	24377.58	6637.0	65698.76	3037.9	33819.96

Table 6
Cost Summary of the FGD Systems Analyzed (FY81 Dollars)

Process	Double-Alkali	Limestone	Sodium	Magnesium Oxide
Capital cost	16,500,000	10,824,000	23,500,000	18,900,000
First year O&M costs*	2,817,000	2,486,000	6,637,000	3,038,000
15-Year O&M present-value annual costs*	24,575,000	24,378,000	65,699,000	33,820,000

* These figures do not include particulate removal or waste disposal.

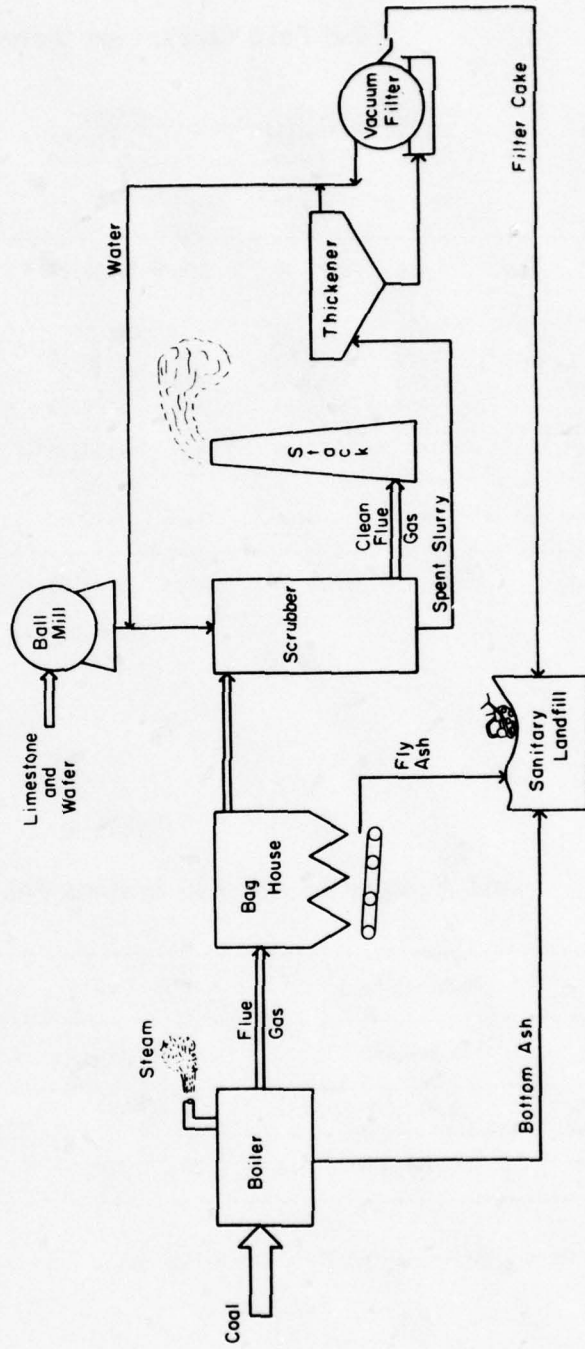

Figure 1. Limestone slurry scrubbing system.

in a landfill with the boiler fly ash and bottom ash. The stack gas is reheated and discharged to the atmosphere.

Magnesia Slurry Scrubbing

Figure 2 shows the magnesia slurry scrubbing technique. Stack gas is fed directly from the boiler to a two-stage venturi scrubber. The first stage uses water to remove particulate matter (a baghouse may be substituted for the first stage) and the second stage uses a recirculating slurry of magnesium oxide (MgO) and reacted magnesium-sulfur salts in water to remove SO_x . The slurry from the SO_x scrubber is dewatered, dried, and calcined with coke, producing concentrated SO_2 , which can be fed into an acid plant, and MgO , which is recycled. The stack gas must be reheated before discharge.

Sodium Solution Scrubbing

The sodium solution method for FGD is diagrammed in Figure 3. The stack gas is passed through a baghouse to remove particulate matter and is then washed in a tray scrubber with a multistage recirculating solution of sodium salts in water for SO_x removal. Sodium sulfate crystals are purged from the system. The sodium bisulfite solution is thermally decomposed, driving off concentrated SO_2 . The resulting sodium sulfite solution is recycled to the scrubber, and the SO_2 is reacted with methane to reduce it to sulfuric acid. The stack gas must be reheated before discharge.

Double Alkali Scrubbing

In the double alkali system, illustrated in Figure 4, stack gas can be fed directly to a venturi scrubber for particulate and SO_x removal or to a baghouse for particulate removal and to a contactor scrubber (low energy) for SO_x removal. SO_x is absorbed in a solution of sodium sulfite (Na_2SO_3), sodium bisulfite ($NaHSO_3$), and sodium sulfate (Na_2SO_4). As SO_x is absorbed the sodium sulfite is converted to sodium bisulfite, and a bleed stream is piped to a regeneration loop where it reacts with slaked lime [$Ca(OH)_2$]. Sodium sulfite is regenerated and returned to the system, while the calcium sulfite ($CaSO_3$) precipitate is thickened and pumped to a vacuum filter. The filter cake is disposed of as a solid waste.

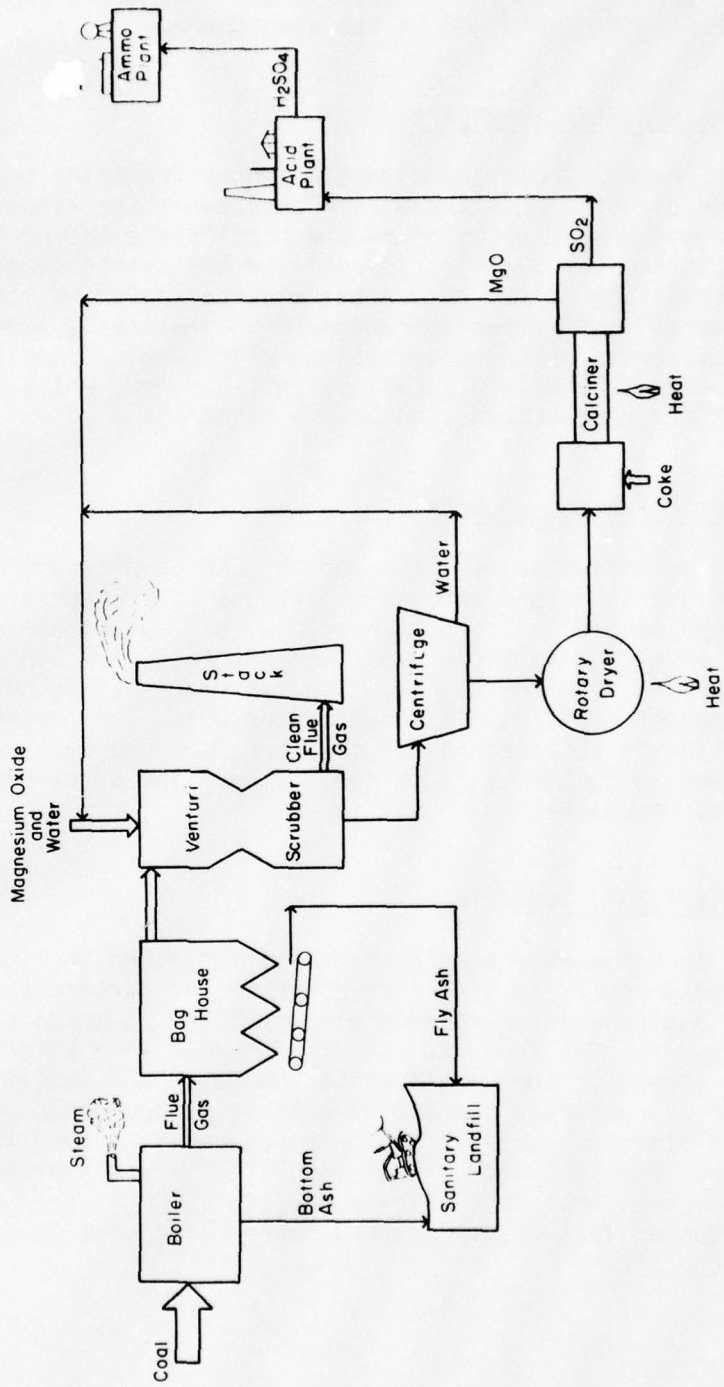

Figure 2. Magnesia slurry scrubbing system.

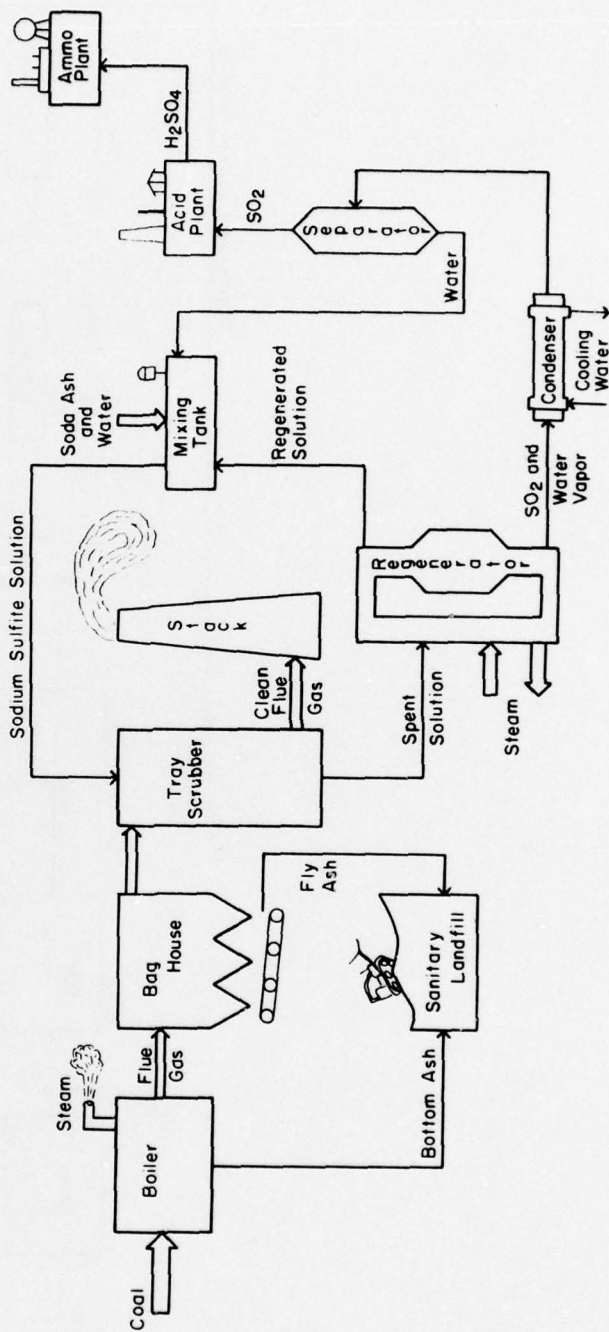

Figure 3. Sodium solution slurry scrubbing with regeneration.

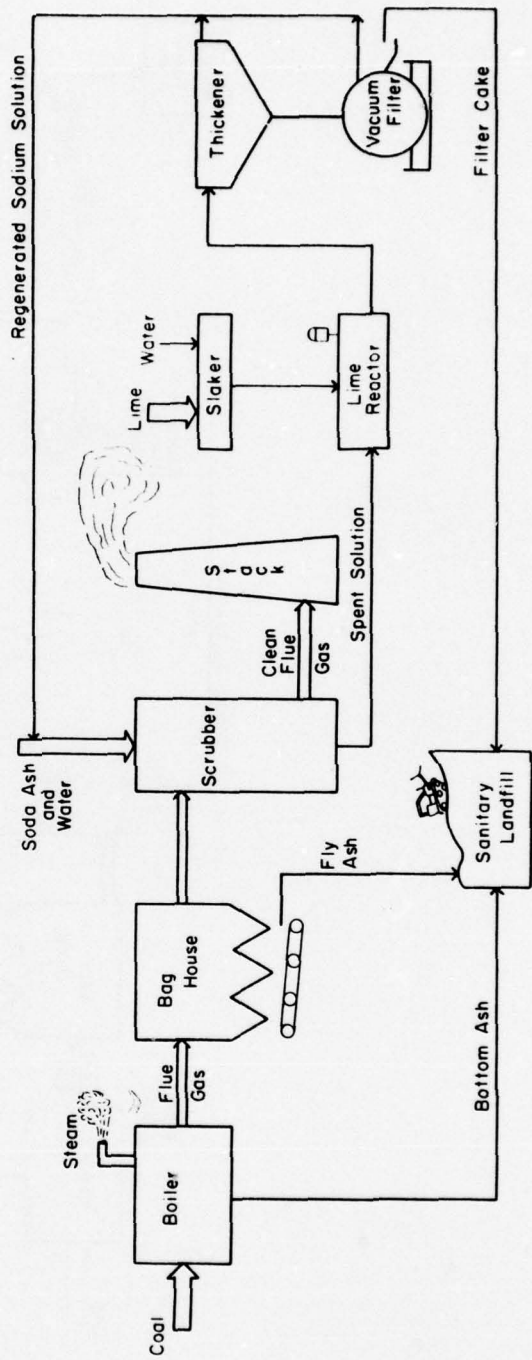

Figure 4. Double alkali scrubbing system.

7 BY-PRODUCT USE AND DISPOSAL

General

All combustion and pollutant removal systems produce by-products which may be re-used by the process, used elsewhere in the plant, sold on the open market, or disposed of in an environmentally sound manner. The optimum combustion and pollutant removal system will use the by-products produced in satisfying both economic and environmental constraints.

Since waste by-product open markets are historically unstable and unpredictable, this investigation considered the "worst" case of no available by-product markets when calculating disposal costs. In reality, the Joliet AAP power plant operator may find a local intermittent market for fly ash, bottom ash, and limestone/lime scrubbing slurry which could reduce actual disposal costs.

Bottom Ash Disposal

One of the main by-products of coal combustion is bottom ash. The SBH burning Illinois No. 7 Danville Coal (the worst case) would produce 402 lb of bottom ash per boiler per hour. This bottom ash can be removed in a dry state using pneumatic or auger conveyor systems or in a wet state as a slurry containing 10 percent solids. In a dry system, the ash would be stored in an ash hopper or silo and periodically trucked to a landfill for disposal. In a wet system, the ash can be chemically treated and pumped to a 10-acre ash pond, or it can be mechanically dewatered using a gravity thickener and rotary vacuum filter with chemical stabilization to produce a "dry" filter cake which can be taken to a landfill. Wet systems produce a supernatant liquid which can either be reused as a transport medium or discharged. Discharged supernatant liquids would probably have to be treated to adjust their pH and to reduce dissolved solids before the liquids enter the water course. With the ponding approach, it would also be necessary to plan for the recovery of the pond area after its sedimentation storage capacity has been reached (15 yr in this study). Table 7 summarizes capital costs and Table 8 summarizes O&M costs.

Fly Ash Disposal

The two main exhaust contaminants produced by coal combustion are suspended particulates (fly ash) and SO_2 . The SBH will produce 1608 lb of fly ash per boiler per hour when burning Illinois No. 7 Danville coal (the worst case). This fly ash can be removed using baghouses, electrostatic precipitators (ESPs), or venturi scrubbers. The baghouse and ESP systems allow the fly ash to be handled dry, stored in silos,

Table 7
Capital Costs for By-Product Disposal Alternatives

<u>Disposal Alternative</u>	<u>1978 \$</u>	<u>1981 \$</u>
<u>Unlined Ponding:*</u>		
Bottom ash	\$39,000	\$53,000
Bottom and fly ash	\$193,000	\$263,000
Limestone slurry	\$3,309,000	\$4,502,000
All slurries	\$3,502,000	\$4,864,000
<u>Low-Cost Lined Ponding</u>		
Bottom ash	\$93,000	\$127,000
Bottom and fly ash	\$976,000	\$1,328,000
Limestone slurry	\$3,849,000	\$5,237,000
All slurries	\$4,825,000	\$6,564,000
<u>High-Cost Lined Ponding</u>		
Bottom ash	\$515,000	\$701,000
Bottom and fly ash	\$2,411,000	\$3,280,000
Limestone slurry	\$8,069,000	\$10,978,000
All slurries	\$10,480,000	\$14,258,000
<u>Mechanical Dewatering</u>		
Bottom ash	\$383,000	\$521,000
Bottom and fly ash	\$1,332,000	\$1,812,000
Limestone slurry	\$2,256,000	\$3,069,000
All slurries	\$3,580,000	\$4,881,000

* Because of the high water table at JAAP, the Illinois EPA would probably require a lined pond.

Table 8

Operating and Maintenance Costs for By-Product Disposal Alternatives

Disposal Alternative	Annual O&M Costs		15-Yr Life Cycle Costs (1981 \$)
	1978 \$	1981 \$	
<u>Ponding</u>			
Bottom ash	\$34,000	\$43,000	\$343,000
Bottom and fly ash	\$170,000	\$215,000	\$1,717,000
Limestone slurry	\$365,000	\$461,000	\$3,682,000
All slurries	\$535,000	\$675,000	\$5,391,000
<u>Mechanical Dewatering</u>			
Bottom ash	\$131,000	\$165,000	\$1,318,000
Bottom and fly ash	\$644,000	\$813,000	\$6,493,000
Limestone slurry	\$1,383,000	\$1,746,000	\$13,944,000
All slurries	\$2,027,000	\$2,559,000	\$20,436,000

and periodically trucked to a landfill. The scrubber system removes the fly ash in a water medium and produces a slurry containing 10 percent solids. This slurry must either be ponded or mechanically dewatered. Again, the slurry and supernatant liquid would have to be chemically treated prior to disposal. Selecting the ponding alternative for both fly ash and bottom ash would require a 34-acre pond, which would have to be "recovered" after its 15-yr useful lifespan. Table 7 summarizes the capital costs and Table 8 contains the O&M costs for these fly ash disposal alternatives.

FGD Sludge Disposal

The SBH will produce 2160 lb of SO₂ per boiler per hour when Illinois Murphysboro coal is burned (the worst case). Approximately 90 percent of this SO₂ can be removed using a flue-gas desulfurization system.

The limestone/lime scrubbing system is a "throwaway" process which produces 335,000 gal/day of a slurry containing 10 percent solids. Ponding this slurry would require chemical stabilization and a 100-acre pond. Mechanical dewatering would require chemical stabilization and would produce 260 tons/day of a filter cake containing 60 percent solids. The filter cake would have to be landfilled. The supernatant liquid from either process could be recycled to the FGD system or chemically treated and discharged. Use of the ponding alternative will require that a plan be made for recovery of the pond area or the

continual maintenance of the area as a recreation pond. Table 7 summarizes the capital costs and Table 8 contains O&M costs for limestone/lime slurry disposal.

The double alkali FGD system is also a "throwaway" process which produces 236 tons/day of a filter cake containing 65 percent solids. Unlike the limestone/lime FGD system, the double alkali system uses mechanical dewatering to recover and recycle the sodium-based scrubbing solution. Costs for recovering the solution and for filter cake stabilization and disposal would be similar to those listed in Tables 7 and 8 for mechanical dewatering of the limestone/lime slurry.

FGD By-Product Disposal

The magnesium oxide FGD system is a recovery process which produces sulfuric acid as its major by-product. The SO_2 is removed by a magnesium oxide scrubbing solution which produces a crystallized magnesium sulfite hydrate. A centrifuge is used to concentrate the crystals, with the supernatant liquid being returned to the scrubbing slurry. The magnesium oxide is thermally regenerated and returned to the scrubbing slurry. Capital and operating costs for a magnesium oxide system at the SBH could possibly be reduced by using an existing 100-ton/day sulfuric acid plant to convert the 5- to 16-percent SO_2 exit gas from the oxide recovery process to acid. A small sulfuric acid plant may have to be added to handle low-load operating situations.

The sodium solution scrubbing system produces a concentrated SO_2 stream which can be used to make a sulfur cake or sulfuric acid. Operation of the sodium system requires large volumes of water for stack-gas cooling and for the scrubbing solution. Using the sodium process at the SBH would require 13,700,000 gal/day of cooling water. This water would probably have to be cooled in a cooling lake or in cooling towers to reduce its temperature to meet recycle requirements or Illinois EPA thermal discharge requirements. Approximately 210,000 gal of spent scrubbing solution will be discharged daily. This process water will require some form of physical and chemical treatment prior to discharge. The cost and amount of treatment required will be a function of state regulations and the condition of the wastewater. Again, the capital and operating cost of the sodium process could be reduced by using an existing 100-ton/day sulfuric acid plant to produce acid. Acid production during low-load operating situations would have to be handled by a small add-on acid plant.

Tables 7 and 8 show the costs of the various waste disposal systems. It should be noted that, depending on local conditions, a dry, wet, or combination of dry and wet system may be required. Also note that ponding is the least expensive system to use over the lifetime of the facility but that mechanical dewatering with landfilling is a more environmentally sound way of storing the waste.

8 USE OF COAL-DERIVED FUEL AT JAAP

General

The feasibility of using a clean, coal-derived fuel at the SBH was evaluated because of its apparent potential for reducing the costs of both pollution abatement and restoration of steam production capability. The investigation revealed no potential long-term supply of clean, coal-derived fuel in the Joliet-Chicago area. Accordingly, a technology review was conducted to determine what coal-to-clean fuel conversion processes could be installed and operated at JAAP to feed the SBH. The review evaluated proven technologies for the gasification and liquefaction of coal, and resulted in selection of the Koppers-Totzek (KT) coal gasification process as a candidate for use at JAAP.

Process Description

The KT process uses an atmospheric-pressure, oxygen-blown, entrained-flow gasifier to produce synthesis gas with a calorific value of approximately 300 Btu/SCF. The composition of the gas is given in Table 9. Oxygen and dry pulverized coal (70 percent through 200 mesh) are mixed and introduced through a pair of coaxial burners arranged so that their jet discharges converge. Both the volatiles and char are converted primarily to carbon monoxide and hydrogen. About half of the ash falls into a quench tank below the gasifier, while the other half exits as fly ash in the product gas. The product gas is cooled in a waste heat boiler after passing through a spray quench to solidify molten ash. After further cooling and the removal of particulates by two-stage venturi scrubbing, the product gas passes through a sulfur removal system and then is burned in a boiler.

The KT process is fully commercial, with more than 30 gasifiers operating throughout the world.

Application of the KT Process at JAAP

A KT plant designed to produce synthesis gas in quantities sufficient for continued full-load operation of the SBH could be located in an open area immediately north of the existing facility. The plant could be designed to allow for future expansion so that it could ultimately serve both the SBH and the NBH. An elemental sulfur recovery line could be included to reclaim that product for use in the production areas of JAAP. A detailed study taking into account DOD long-range goals would be necessary to determine whether this alternative would be cost effective.

Table 9

Composition of Coal-Derived Gas From Koppers-Totzek Process

Constituent*	(present, by volume)			
	Coal Type			
	Western	Illinois	Eastern	Eastern
CO	58.68	55.38	55.9	52.5
CO ₂	7.04	7.04	7.18	10.0
H ₂	32.86	34.62	35.39	36.0
N ₂	1.12	1.01	1.14	1.1
H ₂ S	0.28	1.83	0.35	0.4
COS	0.02	0.12	0.04	0.4
CH ₄	---	---	---	---
C ₂ H ₄ ^{m,n}	NA**	NA	---	---
H ₂ O	---	---	---	---
S (gm/MBtu)	---	---	---	---
HHV (Btu/SCF)	295	290	294	286

* Eastern A and B were taken from two different sources.

** NA-Data Not Available

Cost Estimate for the KT Process

Conversations with representatives of the Koppers Engineering Company, Pittsburgh, PA, revealed that a current-dollar investment ranging between \$25,000,000 and \$30,000,000 would be required to establish a turnkey KT coal gasification plant with sulfur recovery at JAAP to serve the SBH alone. Applying the construction midpoint price hike factor of 1.46, as described in Chapter 5 of this report, the cost range would be from \$36,500,000 to \$43,800,000.

Installing a KT coal gasification plant at JAAP would reduce the costs of restoring the SBH to service by \$2,765,000, thus reducing the FY80 funding requirement from \$7,662,300 to \$4,897,300.

Nevertheless, the total required capital investment, \$54,859,500, would be higher than that for any of the other alternatives evaluated in this investigation, as shown in Table 10. Approximately 91 percent of this investment is for a KT coal gasification plant, and 9 percent is for restoring the SBH to service burning coal-derived gas.

Table 10

Estimated Investment Cost for Constructing a Coal Gasification Plant
and Restoring the SBH to Burn Coal-Derived Gas

Item	Current- Year (FY78) Cost (\$1000's)	Construction Midpoint (FY81) Cost (\$1000's)
Coal Gasification Facility		
Turnkey KT coal gasification plant	27,500.0	40,150.0
Add 25% contingency	6,875.0	10,037.5
Total coal gasification facility	<u>34,375.0</u>	<u>50,187.5</u>
Restoration of SBH		
Burners, controls and safety system (new)	875.0	1,277.5
Furnaces	90.0	131.4
Draft system	30.0	43.8
Water treatment system (new)	1,500.0	2,190.0
Startup, shakedown, operator Training	35.0	51.1
Inspection and testing	30.0	43.8
Subtotal	<u>2,650.0</u>	<u>3,737.6</u>
Add 25% contingency	640.0	934.4
Total restoration cost	<u>3,290.0</u>	<u>4,672.0</u>
 FY80 MCA Project Funding Estimate	 37,575.0	 54,859.5

9 COMPARATIVE LIFE-CYCLE ANALYSIS

General

There are many options for burning high-sulfur coal in an environmentally sound manner at the JAAP. Certain factors must be taken into consideration, such as: (1) the facility will continue to be used on a standby basis, (2) the present coal-burning boiler will be upgraded, and (3) a baghouse for particulate removal will be left in the FY80 MCA program.

The importance of the facility's future use is seen when the various FGD systems are analyzed. The simpler systems, such as the limestone/lime slurry type, are easier to shut down and start up than more complex systems such as sodium scrubbing type, which requires approximately 6 months to start up.

It must also be determined whether the present boiler will be retrofitted with one of the various FGD systems or whether a new boiler will be installed. FGD systems are always less expensive to install on a new boiler. However, the SBH at Joliet is in repairable condition and there are clear economic advantages to rehabilitating rather than replacing it.

Particulate matter must be cleaned from the stack gas at the SBH because of state air pollution regulations. Various methods for particulate removal could be used at the SBH. Electrostatic precipitators (ESPs) work well when designed correctly and when used on coals with particular resistivity characteristics. However, the Army's method of purchasing could result in considerable variation in the coals supplied to Joliet. The particulates from some of them would not be collected efficiently in an ESP; for example, the particulate matter produced when low-sulfur western coals are burned is not efficiently collected in ESPs.

Some wet scrubbing systems use venturi scrubbers for SO_x removal. It would be relatively easy to install a two-stage scrubber, one for particulate matter and one for SO_x removal. This option would eliminate the need for a baghouse. However, a baghouse could be used for particulate removal with any of the FGD systems chosen.

Power Plant and Particulate Matter Removal Costs

For the purpose of this study, it is assumed that the existing power plant will be upgraded and retrofitted with a particulate matter removal and FGD system. The cost of the power plant rehabilitation would be \$7.7 million (Table 3), and that of the baghouse, which is already in the FY80 MCA program, is \$5.6 million.

FGD System Costs

Table 6 compares the total cost of the four FGD systems.

Waste Disposal Costs

It is apparent from Chapter 7 that provisions must be made to dispose of bottom ash, fly ash and, for the limestone or double-alkali systems, a slurry or dewatered sludge. All waste materials from the limestone system can be disposed of in wet form through ponding or by mechanically dewatering them and placing them in a landfill. Another alternative for the limestone system is to pond the bottom ash, handle the fly ash dry, and dewater the sludge. The various combinations possible for waste disposal are shown in Tables 7 and 8.

Table 11 shows the lowest cost option available for the complete rehabilitation of the SBH at JAAP to burn coal.

Table 11
Cost Summary

	Capital Cost (FY81) (\$ million)	15-Year Present Value Annual Cost (FY81) (\$ million)
1. Rehabilitate Power Plant	7.7	
2. Baghouse in FY80 MCA	5.6	5.8
3. Limestone FGD	10.8	24.4
4. Waste Disposal (low-cost lined pond)	<u>6.6</u>	<u>5.4</u>
TOTAL	\$30.7	\$29.7

10 CONCLUSIONS AND RECOMMENDATIONS

The most cost-effective way to retrofit the SBH to burn high-sulfur coal at the JAAP is to upgrade the present boiler, install a baghouse, install a limestone FGD system, and pond the waste material (Table 11). Site characteristics have not been specifically included in the analysis. These characteristics may require some modifications to the lowest cost system.

It is therefore recommended that the above system be included in the earliest possible MCA program and that a detailed coordinated study be conducted at the Joliet AAP to determine whether there are any controlling local factors which would alter the recommended system.

APPENDIX: ECONOMIC ANALYSES

General

This appendix discusses the methods used to obtain capital, annual, and 15-year life-cycle present-value costs of the systems evaluated in this study.

Capital Costs

Capital cost information was obtained from manufacturers, from vendors, and through application of established industrial cost-estimating procedures. Many capital costs were obtained from unsolicited proposals received by the Chief Engineer at JAAP for alternative boiler flue-gas desulfurization systems.

Since capital costs were initially provided in FY78 dollars, it was necessary to adjust them to the future project date to establish the true project-year investment costs and funding requirements for each alternative. Based on the time required for competitive bidding, design, and component acquisition and installation, the first day of FY81 (i.e., FY80 MCA funding) was established as the construction mid-point. Investment costs were increased 8 percent per year for the 4 years FY78 through FY81 in accordance with AR 415-17. A geographic factor of 1.02 was used for the Chicago region. For SBH restoration using long-established technology, a technology update factor of 1.05 was used. For flue-gas desulfurization systems using recently established technology, a technology update factor of 1.10 was used. A blanket 25-percent contingency factor was employed for all capital cost estimates. Hence, a \$1.00 FY78 boiler plant restoration expenditure would require FY80 funding of

$$\$1.00 \times 1.08 \times 1.08 \times 1.08 \times 1.08 \times 1.02 \times 1.05 \times 1.25 = \$1.82 \quad [\text{Eq A1}]$$

A \$1.00 FY78 expenditure for a flue-gas desulfurization system would require FY80 funding of

$$\$1.00 \times 1.08 \times 1.08 \times 1.08 \times 1.08 \times 1.02 \times 1.10 \times 1.25 = \$1.91 \quad [\text{Eq A2}]$$

Recurring Costs

To facilitate a comparative economic analysis of alternative flue-gas treatment systems, their 15-year present-value life-cycle costs were determined using the data shown in Table A1.

Table A1
Data for Economic Analyses

ITEM	UNIT COST	SHORT-TERM ESCALATION RATE (%)					LONG-TERM DIFFERENTIAL ESCALATION RATE	15-YEAR CUMULATIVE UNIFORM SERIES FACTOR
		FY78	FY79	FY80	FY81	FY81		
Design, Construction	-----	8.0	8.0	8.0	8.0	8.0	-----	-----
No. 6 Fuel Oil	\$0.38/Gal	16.0	16.0	16.0	14.0	14.0	8.0	12.978
Electrical Power	\$0.03/kWh	16.0	16.0	16.0	13.0	13.0	7.0	12.117
Natural Gas	\$0.19 Therm	15.0	15.0	15.0	14.0	14.0	8.0	12.978
Coal	\$30.00/Ton	10.0	10.0	10.0	10.0	10.0	5.0	10.639
Steam (Coal)	\$4.20/klb	10.0	10.0	10.0	10.0	10.0	5.0	10.639
Labor	\$12.00/Man-hour	8.0	7.0	6.5	6.0	6.0	0.0	7.986
Maintenance, Repair	-----	7.1	6.4	6.2	6.0	6.0	0.0	7.986
Process Water	\$0.26/Kgal	6.0	6.0	6.0	6.0	6.0	0.0	7.986
Potable Water	\$0.75/Kgal	6.0	6.0	6.0	6.0	6.0	0.0	7.986
Pebble Lime	\$23.50/Ton	6.0	6.0	6.0	6.0	6.0	0.0	7.986
Sulfur	\$29.00-\$45.00/Ton	6.0	6.0	6.0	6.0	6.0	0.0	7.986
Sulfuric Acid		6.0	6.0	6.0	6.0	6.0	0.0	7.986
Other Chemicals		6.0	6.0	6.0	6.0	6.0	0.0	7.986
Disposal	\$5.00/Ton	6.0	6.0	6.0	6.0	6.0	0.0	7.986

Determining the present value costs required four discrete steps. First, the annual rate at which each system consumed utilities (i.e., line items in Table A1) was determined. These rates are given for each system listed in Table 4. The rates were determined both by reviewing proposals obtained by the Chief Engineer at JAAP and examining literature and data from operating facilities in the field. Second, the current-year (FY78) annual utility costs were determined, by line item, using line-item costs at JAAP (Table A1). For example, a system consuming 1,000,000 kwh/year of electrical power would show a current-year line-item power cost of

$$1,000,000 \times \$0.03 = \$30,000 \quad [\text{Eq A3}]$$

Current-year costs are shown in Table 5 of the text. Third, absolute short-term escalation rates (Table A1) were used to inflate each line-item cost to the starting date, which was assumed to be the first day FY82. Each cost was hence inflated through 4 fiscal years. Inflation rates provided under the Energy Conservation Investment Program were used where available. Thus, for a system requiring \$30,000 in power in FY78, the first-year power cost would be

$$\$30,000 \times 1.16 \times 1.16 \times 1.16 \times 1.13 = \$52,914 \quad [\text{Eq A4}]$$

Project-year costs are shown in Table 4 of the text. Finally, the 15-year present-value life-cycle cost of each line item was determined using cumulative uniform series factors shown in Table A1. The method by which these factors were derived is discussed below. The results show that a system requiring \$52,914 in power during its first operational year (FY81) would have a 15-year life-cycle power cost of

$$\$52,914 \times 12.117 = \$641,159 \quad [\text{Eq A5}]$$

Life-cycle costs are shown in Table 5 of the text. In this investigation, the sum of the present-value life-cycle costs of the alternative flue-gas treatment technologies served as the basis for their economic comparison.

Present-Value Method of Analysis

Present-value life-cycle costs were computed using a tabular method with single amount factors corresponding to each of 15 years of economic life, the appropriate long-term differential inflation rate, and a discount rate of 10 percent. In accordance with AR 11-28, the single amount factors were derived by averaging standard P/F factors from compound interest tables for the n^{th} and the $n-1^{\text{th}}$ years to obtain the single amount factor for the n^{th} year. In this investigation, the following function was used to obtain the appropriate single amount factor in the cost analyses:

$$\text{SAF}(n) = \left(\frac{1}{(1+I-i)^n} + \frac{1}{(1+I-i)^{n-1}} \right) / 2 \quad [\text{Eq A6}]$$

where

SAF(n) = single amount factor for nth year
 I = discount rate = 0.10
 i = long-term differential inflation rate
 n = integer year of project life

The cumulative uniform series factors shown in Table A1 were obtained by summing from n = 0 to n = 15 for systems having an economic life of 15 years. Arithmetically, the cumulative uniform series factor was determined by

$$\text{CUS}(n) = \sum_{n=0}^{n=n} \text{SAF}(n) = \sum_{n=0}^{n=n} \left(\frac{1}{(1+I-i)^n} + \frac{1}{(1+I-i)^{n-1}} \right) / 2 \quad [\text{Eq A7}]$$

where

CUS(n) = cumulative uniform series factor for nth year

or for electrical power,

$$\text{CUS}(15) = \sum_{n=0}^{15} \text{SAF}(15) = \sum_{n=0}^{15} \left(\frac{1}{(1-0.10-0.07)^n} + \frac{1}{(1+0.010-0.07)^{n-1}} \right) / 2$$

It is interesting to note that a discount rate of 10 percent and a long-term differential rate of, say, 7 percent are mathematically equivalent to a discount rate of 3 percent.

CERL DISTRIBUTION

Chief of Engineers

ATTN: DAEN-ASI-L (2)
ATTN: DAEN-MPZ/Charles Smith
ATTN: DAEN-MPE/Lee Garrett
ATTN: DAEN-MPO-U (3)
ATTN: DAEN-RDM (2)

US Army Engr Div
ATTN: Chief, Engr Div
Europe
Huntsville
Missouri River
North Atlantic
North Pacific
Pacific Ocean
South Atlantic
South Pacific
Southwestern

US Army Engr Dist
ATTN: Chief, Engr Dist
Kansas City
Omaha
Baltimore
New York
Norfolk
Alaska
Seattle
Far East
Japan
Mobile
Savannah
Los Angeles
Sacramento
Fort Worth

US Army Armament Materiel
Readiness Command
ATTN: Tom Wash
Rock Island, IL 61201

Joliet Army Ammunition Plant
ATTN: Mr. Ridgway
Joliet, IL 60436

Facilities Engineers

FORSCOM
Ft Campbell, KY 42223
Ft Devens, MA 01433
Ft Hood, TX 76544
Ft Lewis, WA 98433
Ft McPherson, GA 30330
Ft George G. Meade, MD
20755
Ft Sam Houston, TX 78234
Ft Riley, KS 66442
Ft Polk, LA 71459
Ft Ord, CA 93941

TRADOC
Ft Dix, NJ 08640
Ft Belvoir, VA 22060
Ft Monroe, VA 23651
Ft Lee, VA 23801
Ft Gordon, GA 30905
Ft McClellan, AL 36201
Ft Knox, KY 40121
Ft Leonard Wood, MO
65473
Ft Sill, OK 73503
Ft Bliss, TX 79116

USAECOM
Ft Monmouth, NJ 07703
DSCPER
West Point, NY 10996
USATCFE
Ft Eustis, VA 23604
USAIC (3)
Ft Benning, GA 31905
CAC&FL
Ft Leavenworth, KS
66027

USAAVNC
Ft Rucker, AL 36361
AMC
Dugway, UT 84022
USACC
Ft Huachuca, AZ 85613

Defense Documentation Center
ATTN: DDA (12)

Donahue, Bernard A

Evaluation of alternatives for restoring the south boiler house at Joliet AAP to high-sulfur-coal burning capability / by B. A. Donahue, S. A. Hathaway, G. Schanche, S. Struss. --Champaign, IL : Construction Engineering Research Laboratory ; Springfield, VA : available from NTIS, 1979.

43 p. ; 27 cm. (Technical report ; N-66)

1. Joliet Army Ammunition Plant. 2. Boilers-fuel. 3. Coal-sulfur content. I. Hathaway, Steve A. II. Schanche, Gary W. III. Struss, Steven R. IV. Title. V. Series: U.S. Army Construction Engineering Research Laboratory. Technical report ; N-66.