

AD-A069 474

NATIONAL AVIATION FACILITIES EXPERIMENTAL CENTER ATL--ETC F/G 17/7  
PROCEEDINGS OF THE WORLD-WIDE OMEGA DATA BANK CONFERENCE HELD 2--ETC(U)  
APR 79 J J SCAVULLO, J M DAVIS, G H QUINN

UNCLASSIFIED

FAA-NA-79-165

NL

1 of 2  
AD  
A069474



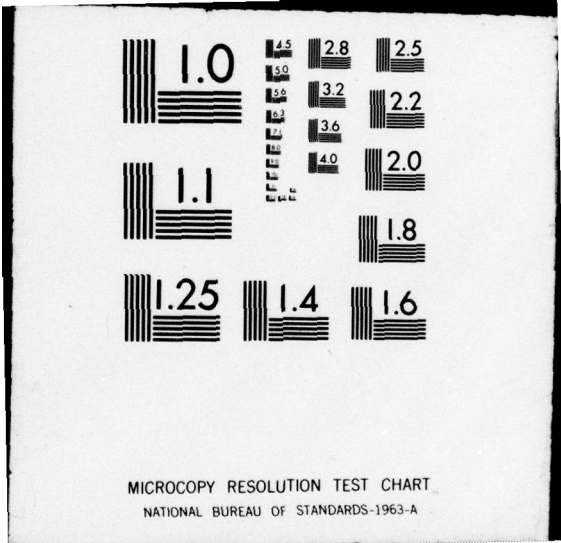

FAA-NA-79-165

12  
B-5

LEVEL

# Proceedings Of The World-Wide Omega Data Bank Conference

A069474

PHILADELPHIA, PENNSYLVANIA  
AUGUST 2-3, 1978

CONDUCTED  
BY  
THE NATIONAL AVIATION FACILITIES  
EXPERIMENTAL CENTER  
(NAFEC)

DDC FILE COPY



DDC  
RECEIVED  
JUN 6 1979  
A

79 05 31 025

DEPARTMENT OF TRANSPORTATION  
FEDERAL AVIATION ADMINISTRATION  
Atlantic City, N. J., 08405

Technical Report Documentation Page

1. Report No. <b>14</b> <u>FAA-NA-79-165</u> ✓	2. Government Accession No.	3. Recipient's Catalog No.	
4. Title and Subtitle <b>6</b> <u>PROCEEDINGS OF THE WORLD-WIDE OMEGA DATA BANK CONFERENCE held 2-3 August 1978, Philadelphia, Pennsylvania.</u>		5. Report Date <b>11</b> <u>Apr 1979</u>	6. Performing Organization Code
7. Author(s) <b>Joseph J. Scavullo, et al</b>		ANA-530	8. Performing Organization Report No. <b>12</b> <u>164</u>
9. Performing Organization Name and Address <b>Federal Aviation Administration National Aviation Facilities Experimental Center Atlantic City, New Jersey 08405</b>		10. Work Unit No. (TRIS)	11. Contract or Grant No. <b>043-311-500</b>
12. Sponsoring Agency Name and Address <b>U.S. Department of Transportation Federal Aviation Administration Systems Research and Development Service Washington, D.C. 20590</b>		13. Type of Report and Period Covered <b>9</b> <u>ending August 1978</u>	14. Sponsoring Agency Code
15. Supplementary Notes <b>10</b> <u>Joseph J. /Scavullo, Jerald M. /Davis, George H. /Quinn, David C. /Scull Peter B. /Morris</u>			
16. Abstract <i>The World-Wide Omega Data Bank Conference, held in Philadelphia, Pennsylvania, on August 2-3, 1978, was attended by 62 persons especially involved with the Omega Navigation System. Some were expressly interested in the certification of this system as sole means of navigation over world-wide air routes, especially over the North Atlantic between Europe and North America. Among those attending were representatives of U.S. Government regulatory agencies, domestic and foreign avionics industries, and the scheduled and nonscheduled airlines both international and domestic.</i>  <i>The conference was called to: (1) discuss the requirement for and feasibility of establishing an Omega data bank as a depository for data illustrative of Omega propagation, (2) to outline the resources available, general plan of operation and conditions for participation by interested organizations, and (3) to complete plans for operation of this cooperative international venture.</i>  <i>The concept, basis of the requirements, and background were explained by speakers representing the Federal Aviation Administration, United States Coast Guard, and private industry. The technical presentation, comments, and suggestions about facilitating the deployment of in-flight data recorders, and the retrieval, processing, and analysis, and proposed distribution of data are covered in these proceedings.</i>			
17. Key Words <b>Omega Navigation System, Omega Data Bank, Data Collection &amp; Distribution, Propagation Characteristics, Antennas, System Accuracy, Modal Interference, Polar Cap Disturbance, Sudden Phase Anomaly</b>		18. Distribution Statement <b>Document is available to the U.S. public through the National Technical Information Service, Springfield, Virginia 22151</b>	
19. Security Classif. (of this report) <b>Unclassified</b>	20. Security Classif. (of this page) <b>Unclassified</b>	21. No. of Pages <b>172</b>	22. Price

240550

15

### METRIC CONVERSION FACTORS

#### Approximate Conversions to Metric Measures

Symbol	When You Know	Multiply by	To Find	Symbol
<b>LENGTH</b>				
in	inches	*2.5	centimeters	cm
ft	feet	30	meters	m
yd	yards	0.9	kilometers	km
mi	miles	1.6		
<b>AREA</b>				
in <sup>2</sup>	square inches	6.5	square centimeters	cm <sup>2</sup>
ft <sup>2</sup>	square feet	0.09	square meters	m <sup>2</sup>
yd <sup>2</sup>	square yards	0.8	square meters	m <sup>2</sup>
mi <sup>2</sup>	square miles	2.6	square kilometers	km <sup>2</sup>
	acres	0.4	hectares	ha

Symbol	When You Know	Multiply by	To Find	Symbol
<b>MASS (weight)</b>				
oz	ounces	28	grams	g
lb	pounds	0.45	kilograms	kg
	short tons (2000 lb)	0.9	tonnes	t

Symbol	When You Know	Multiply by	To Find	Symbol
<b>VOLUME</b>				
tsp	teaspoons	5	milliliters	ml
Tbsp	tablespoons	15	milliliters	ml
fl oz	fluid ounces	30	milliliters	ml
c	cups	0.24	liters	l
pt	pints	0.47	liters	l
qt	quarts	0.95	liters	l
gal	gallons	3.8	liters	l
ft <sup>3</sup>	cubic feet	0.03	cubic meters	m <sup>3</sup>
yd <sup>3</sup>	cubic yards	0.76	cubic meters	m <sup>3</sup>

°F	Fahrenheit temperature	5/9 (after subtracting 32)	Celsius temperature	°C
<b>TEMPERATURE (exact)</b>				

\*1 in = 2.54 (exactly). For other exact conversions and more detailed tables, see NBS Misc. Publ. 286, Units of Weights and Measures, Price \$2.25, SD Catalog No. C1310-286.

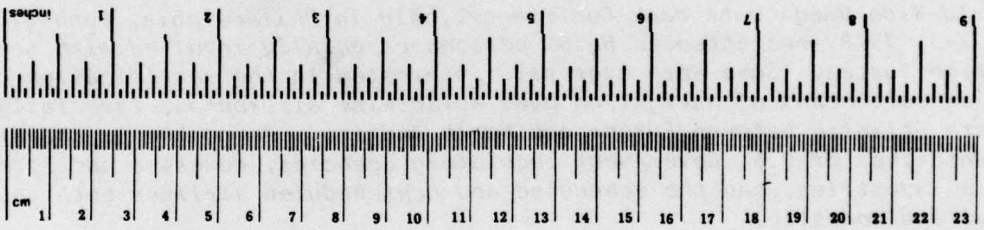

#### Approximate Conversions from Metric Measures

Symbol	When You Know	Multiply by	To Find	Symbol
<b>LENGTH</b>				
mm	millimeters	0.04	inches	in
cm	centimeters	0.4	inches	in
m	meters	3.3	feet	ft
km	kilometers	0.6	miles	mi

Symbol	When You Know	Multiply by	To Find	Symbol
<b>AREA</b>				
cm <sup>2</sup>	square centimeters	0.16	square inches	in <sup>2</sup>
m <sup>2</sup>	square meters	1.2	square yards	yd <sup>2</sup>
km <sup>2</sup>	square kilometers	0.4	square miles	mi <sup>2</sup>
ha	hectares (10,000 m <sup>2</sup> )	2.5	acres	

Symbol	When You Know	Multiply by	To Find	Symbol
<b>MASS (weight)</b>				
g	grams	0.035	ounces	oz
kg	kilograms	2.2	pounds	lb
t	tonnes (1000 kg)	1.1	short tons	

Symbol	When You Know	Multiply by	To Find	Symbol
<b>VOLUME</b>				
ml	milliliters	0.03	fluid ounces	fl oz
l	liters	2.1	pints	pt
l	liters	1.06	quarts	qt
l	liters	0.26	gallons	gal
m <sup>3</sup>	cubic meters	35	cubic feet	ft <sup>3</sup>
m <sup>3</sup>	cubic meters	1.3	cubic yards	yd <sup>3</sup>

°C	Celsius temperature	9/5 (then add 32)	Fahrenheit temperature	°F
<b>TEMPERATURE (exact)</b>				

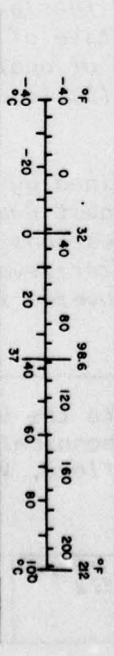

Accession For	NTIS GMA&I
	DDC TAB
	Unannounced
	Justification
By	
Distribution/	
Availability Codes	
Avail and/or	
Dist.	special
	A

PREFACE

The Omega Data Bank Conference was organized by the National Aviation Facilities Experimental Center (NAFEC) and held in Philadelphia, Pennsylvania on August 2-3, 1978. Among the 62 persons who attended, the participants included members of various foreign and domestic elements of government, air carriers, and avionics manufacturers. All had some knowledge and a substantial interest in the Omega Navigation System.

The purpose of the two-day proceedings was twofold; first, to review the basis of the requirement for a new data bank in which to deposit and process records of world-wide Omega propagation and, next, on that basis, to organize a viable data bank with international participation.

While several airlines of the United States had begun to seek certification of Omega for air navigation, the criteria established for such certification did not include the technical information to be collected in the new data bank of NAFEC. Propagation of very low frequency (VLF) radio signals is known to be subject to many factors of which some follow long-term cycles lasting many years. Test results over too short a term could be woefully inadequate if not dangerously misleading. Data collected at fixed points on the ground might not tell a true and complete story about the airborne environment along oceanic jet routes. Furthermore, data collected in nonoperational aircraft with preproduction equipment during

a few dedicated flight tests had proven too little, too expensive, and too soon.

The proper approach to Omega data collection seemed clearly to require automatic recorders in operational aircraft of the commercial and industrial operators so that marginal costs of the collection process would be manageable. Furthermore, principles of good experimentation dictated that data be collected with several different models of bonafide production equipment, sold through competition, and installed with the kind of engineering effort appropriate to commercial standards. So the data bank could not have been established much earlier--there simply were too few operators equipped with proven avionics prior to the conference. Most prospective users were still evaluating Omega at the time of the conference.

Now that the preparation of recorders and interfacing, promised during the conference, have advanced substantially, these proceedings will be useful to prospective participants during their deliberations about the extent to which they will want to become involved. Other readers will find these proceedings useful as background for clarifying their expectations of the Omega data bank and the products it will issue from time to time.

On the first day, Mr. Joseph Del Balzo, Acting Director of NAFEC, set the theme of the conference. Papers were then presented which

reflected the abrupt upsurge of interest among air carriers, operators, and government in the substitution of Omega for Loran-A as a supplemental aid to navigation. Other discussions emphasized the technical problems of radio propagation at the very-low Omega frequencies.

Through the several presentations of the first day, the group developed a common background by which all were prepared to agree on the importance of this international cooperative venture and to respond to invitations later to join the bank.

The background presentations led to a consensus that the bank should emphasize the observation of Omega signal reception in normal flight along world air routes. Under the influence of diurnal variations in the ionosphere-earth-waveguide characteristics, and under the influence of incompletely-defined geophysical phenomena and solar activity, Omega signals could be disturbed. Knowledge of the geographical and temporal distribution, frequency, extent and effects of these uncontrollable and often unpredictable factors on Omega performance is limited. The collection of records in flight was expected to add considerably to this knowledge and, therefore, to add confidence in the future to decisions about application and improvements to the Omega Navigation System.

On the second day, the conference covered the concept of the bank, the hardware needed for data collection, the expected deployment and installation of the data

recorders and the operation of the bank. Since the participants were promised a copy of the proceedings when published they were not compelled to make copious notes. An audio tape recorder was operated throughout in order to facilitate preparation of the proceedings.

Omega manufacturers, known and prospective users, and various government agencies were represented. Participants are listed at the end of the appendices. The list includes names from Africa, Canada, England, France, Holland, and Japan.

The Chairman is especially grateful for the cooperation of all the speakers who made presentations and who added to the discussion. However, Mr. Richard K. Ohman not only organized arrangements for the conference, so that the proceedings seemed effortless, but through his knowledge of the affair he was able to bring all the material for these proceedings together as a unified and readable manuscript. Those who benefit from this publication will be indebted to him.

All the tapes were transcribed personally by the Conference Chairman. In some cases, the record was not clear, either because of faulty microphone technique or some technical difficulty. In the event that an error of transcription is found in this text, the blame must rest with the Chairman, who did his best to edit the presentations.

Joseph J. Scavullo  
Conference Chairman

TABLE OF CONTENTS

	Page
<b>INTRODUCTION</b>	
<i>Welcoming Address - J. M. Del Balzo .....</i>	1
<b>PRESENTATIONS</b>	
<i>Introduction To The Omega Data Bank Conference - J. J. Scavullo ...</i>	3
<i>Omega Certification Programs - J. M. Davis .....</i>	9
<i>The Research And Development Program For Long Distance .....</i>	16
<i>Navigation - George H. Quinn</i>	
<i>Management Of The Omega Navigation System - D. C. Scull .....</i>	19
<i>Evaluation Of Omega Propagation Models - P. B. Morris .....</i>	29
<i>Omega Performance In Air Carrier Operations - P. R. J. Reynolds ...</i>	41
<i>Solar Flare Forecasting And Effects On Omega - Dr. P. Levine .....</i>	42
<i>A Bank For Omega Propagation Data - Dr. L. Rzunca .....</i>	53
<i>Comments And Suggestions - Dr. F. H. Reder .....</i>	66
<i>Concept Of An Omega Data Bank - J. J. Scavullo .....</i>	72
<i>Engineering Requirements - R. Erikson .....</i>	74
<i>A Cassette Tape Recorder For Airborne Omega Data - J. Pohlke .....</i>	83
<i>Modification Kit For Digital Data Recording From Omega .....</i>	86
<i>Navigation Set CMA-740 - Dr. J. C. Lanoue</i>	
<i>Digital Data Recording From Tracor Model 599R Omega Sets - .....</i>	87
<i>T. Armstrong</i>	
<i>Establishment Of The Omega Data Bank At NAFEC - J. J. Scavullo ....</i>	89
<b>APPENDICES</b>	
A - <i>Synopsis Of Dr. Rzunca's Data Presentation</i>	
B - <i>Questions, Response, and Comment Following Presentation</i> <i>Given By R. Erikson</i>	

**TABLE OF CONTENTS (Continued)**

**C - Technical Details**

**D - Questions, Response, and Comment Following Presentation  
Given By J. D. Lanoue**

**E - Inter-Organization Participation Agreement Form**

**ATTENDANCE LIST**

LIST OF ILLUSTRATIONS

<i>Figure</i>		<i>Page</i>
1	<i>FAA Convair CV-880, N-42 .....</i>	6
2	<i>Omega Measurement Instrumentation Installed In Convair N-42 ....</i>	7
3	<i>Omega Antenna Farm Installed on Convair N-42 .....</i>	8
4	<i>Principal Types Of Omega Transmitting Antennas .....</i>	23
5	<i>Proposed World-Wide Distribution Of Omega Monitor Sites .....</i>	24
6	<i>Flow Chart For Omega System Validation Data .....</i>	25
7	<i>The Earth--Ionosphere Waveguide .....</i>	35
8	<i>Examples of Spatial Modal Interference Along Inhomogeneous/ Night Paths .....</i>	36
9	<i>Western Pacific OMEGA Validation Test Program Flight Paths .....</i> <i>and Fixed Monitor Sites</i>	37
10	<i>Modal Degeneracy--Signal Characteristics Versus Distance .....</i> <i>(Hawaii to Samoa at 10.2 kHz)</i>	38
11	<i>Observed And Predicted Monthly Sunspot Numbers .....</i>	46
12	<i>Solar Flare VLF Phase Effects .....</i>	47
13	<i>Maximum Phase-Offset Distributions Observed During SPA .....</i> <i>Events on Hawaii To New York Path At 10.2 kHz</i>	48
14	<i>PCA Effects Of Omega Phase, Norway To Hawaii .....</i>	49
15	<i>PROPHET: System Concept .....</i>	50
16	<i>Prototype System Hardware .....</i>	51
17	<i>SID Corrections: No Diurnal Transitions .....</i>	51
18	<i>Schematic Diagram For Sorting Omega Geographically In The .....</i> <i>Data Bank</i>	61
19	<i>Omega Track Record Of Probe Flights Flown During January .....</i> <i>And July 1976 Using A Portable Recorder Onboard A Trans</i> <i>World Airlines Boeing 707</i>	62

LIST OF ILLUSTRATIONS (Continued)

Figure		Page
20	Signal-To-Noise Fluctuations .....	63
21	Portable Recorder With Model 6106/6406 Tape Deck..... Manufactured By Raymond Engineering, Inc.	78
22	Three-Quarter ATR Short Rack Containing Raymond Engineering's .. Incremental Cassette Recorder And The Associated Control Electronics Manufactured By Bendix	78
23	Signal-To-Noise Graphic Data, Station Norway, July 19, 1978 .... Obtained While En route From San Juan, Puerto Rico to Bermuda	79
24	Airborne Interface And Recording Set Manufactured By..... Base Ten Systems, Inc.	80
25	Cassette Data Identity Label .....	95
26	Business Session, World-Wide Omega Data Bank Conference, ..... Mr. Joseph J. Scavullo, Chairman	96

LIST OF TABLES

Table		Page
1	<i>Design Of Transmitter Antennas At The Omega Ground Stations</i> ....	26
2	<i>Dissemination Of Omega Status Reports</i> .....	27
3	<i>Phenomena Capable Of Disturbing Omega Signal Propagation</i> .....	28
4	<i>Modal Interference Phenomena</i> .....	39
5	<i>Development Of A Bank For Airborne Omega Data</i> .....	64
6	<i>Data Sample From Bendix ONS-20 Equipment</i> .....	65
7	<i>Data Sample From Amecom ONS-201 Equipment</i> .....	81
8	<i>Sample Data Message From Bendix ONS-20 To In-Flight Cassette Recorder</i> .....	82

## LIST OF ACRONYMS

<b>ADF</b>	<i>Automatic Direction Finder</i>
<b>ALPA</b>	<i>Airline Pilots Association</i>
<b>ANSI</b>	<i>American National Standards Institute</i>
<b>ARINC</b>	<i>Aeronautical Radio, Incorporated</i>
<b>ATC</b>	<i>Air Traffic Control</i>
<b>ATR</b>	<i>Air Transport Rating</i>
<b>BCD</b>	<i>Binary Coded Decimal</i>
<b>BPI</b>	<i>Bits per inch</i>
<b>CCIR</b>	<i>Comite Consultatif Internationale Radio</i>
<b>CDU</b>	<i>Control Display Unit</i>
<b>C.G.</b>	<i>Center of gravity</i>
<b>CONUS</b>	<i>Continental United States</i>
<b>DC</b>	<i>Direct current</i>
<b>DOD</b>	<i>U.S. Department of Defense</i>
<b>DOT</b>	<i>U.S. Department of Transportation</i>
<b>EMI</b>	<i>Electromagnetic Interference</i>
<b>FAA</b>	<i>Federal Aviation Administration</i>
<b>FSK</b>	<i>Frequency Shift Keyed Signal</i>
<b>GMT</b>	<i>Greenwich Mean Time</i>
<b>HF</b>	<i>High frequency</i>
<b>IBM</b>	<i>International Business Machines</i>
<b>ICAO</b>	<i>International Civil Aeronautics Organization</i>
<b>I/O</b>	<i>Input/Output</i>
<b>INS</b>	<i>Inertial Navigation System</i>
<b>IRG</b>	<i>Inter-record Gap</i>
<b>LAR</b>	<i>Lane Ambiguity Resolution</i>
<b>LED</b>	<i>Light Emitting Diode</i>
<b>MNPS</b>	<i>Minimum Navigation Performance Standard</i>
<b>NAFEC</b>	<i>National Aviation Facilities Experimental Center</i>
<b>NASA</b>	<i>National Aeronautics and Space Administration</i>
<b>NBAA</b>	<i>National Business Aircraft Association</i>
<b>NELC</b>	<i>Naval Electronics Command, U.S. Navy</i>
<b>nmi</b>	<i>Nautical mile(s)</i>
<b>NOAA</b>	<i>National Oceanic and Atmospheric Administration</i>
<b>NOSC</b>	<i>Naval Ocean Systems Center</i>
<b>NOTAM</b>	<i>Notice to Airmen</i>
<b>NTSB</b>	<i>National Transportation Safety Board</i>

<i>ONSOD</i>	<i>Omega Navigation Systems Operation Detail, U.S. Coast Guard</i>
<i>ONS</i>	<i>Omega Navigation System</i>
<i>PCA</i>	<i>Polar Cap Absorption</i>
<i>PPC</i>	<i>Propagation Corrections</i>
<i>RAM</i>	<i>Random Access Memory</i>
<i>RFI</i>	<i>Radio Frequency Interference</i>
<i>RMS</i>	<i>Root Mean Square</i>
<i>RPU</i>	<i>Receiver Processor Unit</i>
<i>RTCA</i>	<i>Radio Technical Commission For Aeronautics</i>
<i>SAFI</i>	<i>Semi-Automatic Flight Inspection</i>
<i>SID</i>	<i>Sudden Ionospheric Disturbance</i>
<i>SNR</i>	<i>Signal-To-Noise Ratio</i>
<i>S/R</i>	<i>Signal-To-Noise Ratio</i>
<i>SPA</i>	<i>Sudden Phase Anomalies</i>
<i>TNT</i>	<i>Trinitrotoluene</i>
<i>TSO</i>	<i>Technical Standard Order</i>
<i>TWA</i>	<i>Trans World Airlines</i>
<i>USCG</i>	<i>United States Coast Guard</i>
<i>V</i>	<i>Volts</i>
<i>VAC</i>	<i>Volts, alternating current</i>
<i>VDC</i>	<i>Volts, direct current</i>
<i>VLf</i>	<i>Very Low Frequency</i>
<i>VOR</i>	<i>Very High Frequency Omnidirectional Range</i>

## INTRODUCTION

### WELCOMING ADDRESS



*Joseph M. Del Balzo  
Federal Aviation Administration*

#### BIOGRAPHY

*Mr. Joseph M. Del Balzo is the Acting Director of the Federal Aviation Administration's National Aviation Facilities Experimental Center (NAFEC), Atlantic City, New Jersey. He holds his B.S. degree from Manhattan College and his M.S. degree from Drexel University. After initial service at NAFEC as Project Manager, he became Program Manager, Systems Research and Development Service; Chief Technical Adviser, European Region, Brussels, Belgium; Chief, Long Distance Navigation Branch; and Senior Program Manager, Office of Systems Engineering Management, Washington, D.C. After a year as Chief, Engineering Management Staff at NAFEC, he became Chief Microwave Landing Systems Division, Washington, D.C. Prior to his appointment as Acting Director, he had been Deputy Director of NAFEC since 1975. Mr. Del Balzo is an active member of the Institute of Navigation, Institute of Electrical and Electronics Engineers, and American Institute of Aeronautics and Astronautics.*

\*\*\*\*\*

*As I look out I see quite a few familiar faces. On behalf of the Department of Transportation, the U.S. Coast Guard, and the Federal Aviation Administration I welcome you to Philadelphia and the discussion of an Omega data bank. I will talk philosophically for a few minutes about Omega. Omega is not new and has been in development for more than 30 years. Why an Omega data bank today? What can be discovered that is new after so much data has been collected already?*

*The present problem is the absence of systematic collection of data about Omega as it applies to air navigation. There has been little interest in the past about such an application. We did not have a Department of Transportation (DOT), until 1967-1968. Prior to then, the Federal Aviation Administration (FAA), U.S. Coast Guard, Navy, and Air Force each handled its own problems in its own way. None were able to look at any navigation system as a national system with prospects for meeting requirements of all users, both civil and military. Now,*

there is congressional interest in finding solutions to consolidated requirements.

Early transoceanic navigation was only as effective as the human navigator. He did better work with a doppler sensor. Eventually the doppler, reinforced by Loran-A, and later the inertial navigation system, displaced the human navigator with the savings of some cost. Optimism was the basis for expecting the more sophisticated equipments to become relatively inexpensive. Recently, Omega has become a viable candidate for the oceanic navigation means, either as the primary tool or as backup to some other means. By now, many are aware of the new requirements to travel to offshore oil rigs. The line-of-sight system, such as VORTAC, is not adequate to reach over the horizon. Interest in Omega as a new system has peaked. The requirements have surfaced; DOT has taken the lead in arousing concern about the multiplicity of navigation systems.

Now, the need is clear to know more about Omega as it applies to air navigation. How reliable is it and how accurate? What kind of errors and how often may they be expected? What do these errors do to navigation?

Air carriers are now requesting certification of Omega either as primary or backup means! But, FAA cannot provide the supporting data alone. Instrumenting and flying one or two of the FAA's test aircraft would be totally inadequate. A lot of cooperation by many people will be necessary to learn what we need to know for full support of civil aviation. That is what our conference is all about. I hope that we all will derive from this conference an understanding of the data that is required and somehow we will find the means to cooperate with one another in making that data available so we all can benefit from it. I thank you for joining us in this effort.

PRESENTATIONS

INTRODUCTION TO THE OMEGA  
DATA BANK CONFERENCE



*Joseph J. Scavullo  
Federal Aviation Administration*

BIOGRAPHY

*Joseph J. Scavullo is the Manager of the Loran-C/VLF/Omega Navigation Program at NAFEC, a position he has held since 1975. He holds a B.S. in mechanical engineering from Stevens Institute of Technology and an MBA from George Washington University. His career in aviation electronics, which began as Navy radar officer, continued at Massachusetts Institute of Technology's (MIT's) Instrumentation Laboratory, the Navy's Bureau of Aeronautics, and, since 1958, at NAFEC. He is a life member of the International Omega Association and also holds membership in the Institute of Navigation, the American Institute of Aeronautics and Astronautics, and the American Society of Mechanical engineers.*

\*\*\*\*\*

*Prior to April 1977, the National Aviation Facilities Experimental Center (NAFEC) had applied a very modest staffing to Omega project activity. Today, eight persons are active in our team in recognition of the maturity of the system.*

*Included are an air traffic control specialist, a doctor of physics, two electronic engineers, two journeymen electronics technicians, a student engineer, and a precollege science-fair winner. Very few government organizations have been able to apply as many as eight persons to such work.*

*We have asked you to a conference, not to a meeting, because there is work to do well beyond the capacity of the NAFEC team. We want your help. We want to lay the groundwork on this first day so that tomorrow we will achieve the structure of an Omega bank to which we all will want to contribute.*

*Prospects for an Omega data bank were meagre 2 months ago. The proposed fiscal year 1978 budget for work at NAFEC on long range navigation systems was, at first, minimal. Today, it is substantial, and the program has extensive in-house support. NAFEC has excellent rapport with the U.S. Coast Guard's Omega Navigation System Operation Detail (ONSOD). NAFEC will fly the 1978 validation mission for ONSOD in a*

Convair CV-880 aircraft (figure 1) in North Atlantic Ocean areas. This 4-week expedition is scheduled to begin on August 23, 1978. Due to rigid maintenance requirements, the aircraft could not be flown to Philadelphia to allow for inspection of the aircraft along with the installed Omega validation instrumentation and the airborne antenna farm. Photographs of the aircraft and instrumentation (figures 2 and 3) are posted at the side of this room.

We will welcome suggestions about experiments we can conduct for industry's benefit in the Convair 880 or in the other test bed aircraft (Convair 580, Boeing 727-100) under our research and development mission. FAA is chartered to foster both air safety and the efficient use of the airspace. We can undertake helpful experiments; yes, but not evaluation of hardware for endorsement purposes.

Only a few years ago the first airlines which adopted Omega as a replacement for LORAN-A had become pioneers out of necessity; many others have been able to hold back because they were not using LORAN-A. Inadequate knowledge of the new system could have resulted in some prospective users prematurely deciding to reject the Omega system. It is also possible that carriers which elect or insist on use of Omega as the sole means of navigation may apply it too ambitiously. As of today, what can be said for sure about the future of Omega? At present, we are facing a peak period of solar disturbances. At the end of the next two years, we may have collected enough data to show

that, despite drastic solar activity, the effects on Omega are not sufficient to interfere with safe air navigation. Or, we may find that there are occasions when anomalous propagation does reduce safety. By cataloging solar events, comparing them with actual Omega experience, we hope to be able, in time, to sort out seasonal fluctuations and local geographic influences from geophysical considerations and solar phenomena.

A smaller number of in-flight digital data recorders have been procured by the government to document the Omega experience. Most of the recorders will be issued to aircraft operators under agreement with NAFEC. Few experimenters and almost no aircraft operators have yet undertaken digital recording in commercial aircraft. But, we now have at our disposal the required resources. We intend to do as much as we can with those resources to examine the commercial air routes of the world along which Omega may be applied. Thus, this first day's program will review the basis of our requirements, the background for the data bank, the work of ONSOD, the technical program of the FAA, and the scope of the data analysis to be accomplished by NAFEC.

During the morning of the second day of this conference, hardware needed to record Omega data will be described. Business aspects of the bank and agreements will be discussed during the afternoon session on the second day. We will ask operators to install and carry recorders, interconnect them with

*their operational Omega, modified for digital output, and send back data cassettes for processing at NAFEC on a regular basis.*

*For your information, a number of relevant documents have been placed on the table at the right side of this room. Please take one each of the following:*

*a. Technical Programs at NAFEC,*

*b. Proceedings of The National Aerospace Symposium, April 25-27, 1978,*

*c. Proceedings of The International Omega Association Symposium, November 1977,*

*d. Folder containing: Omega Data Bank Program Agenda, ICAO circular on aviation use of Omega, and a brochure entitled: "Probing The Airborne Omega Environment, April 1977."*

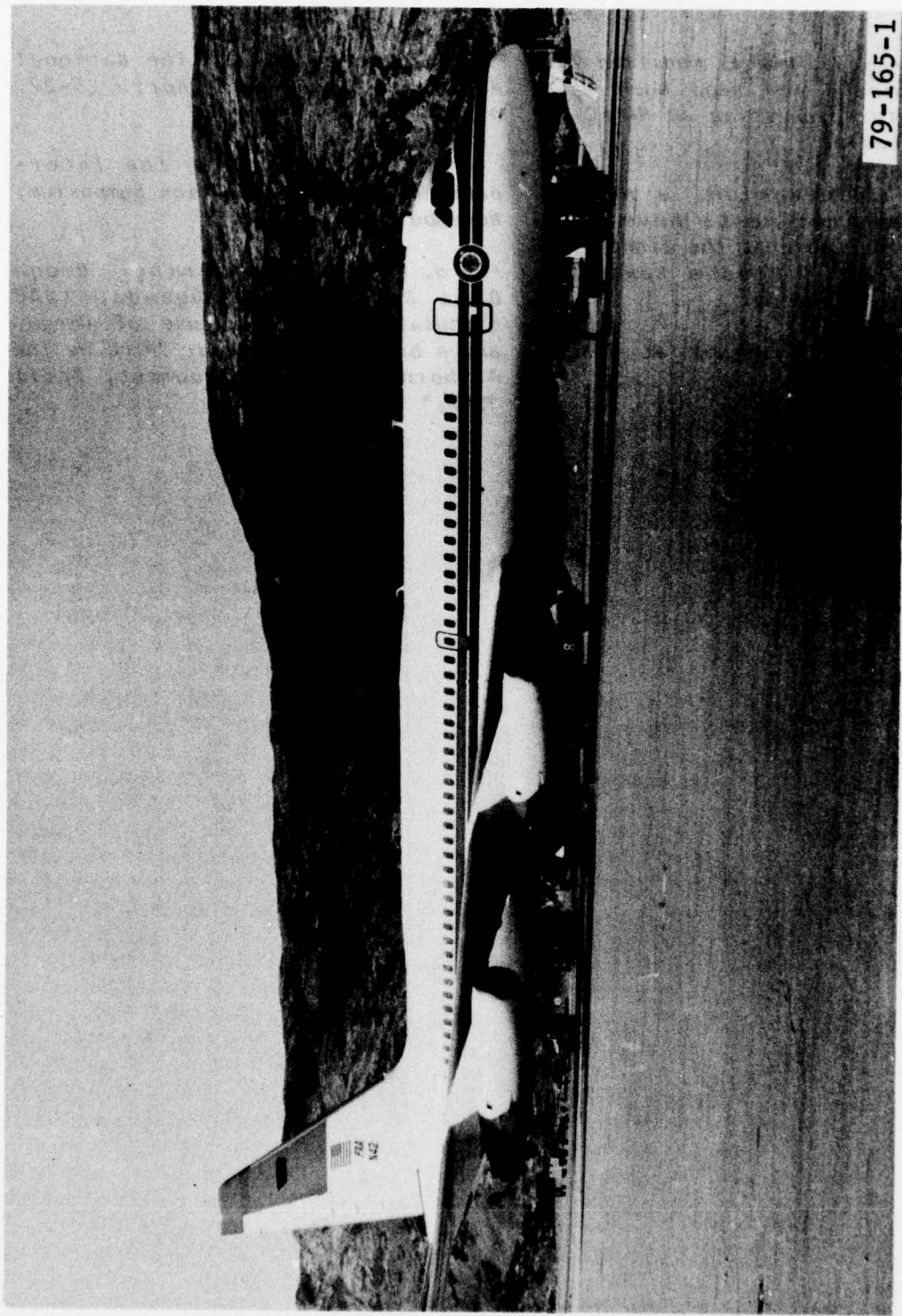

FIGURE 1. FAA CONVAIR CV-880, N-42

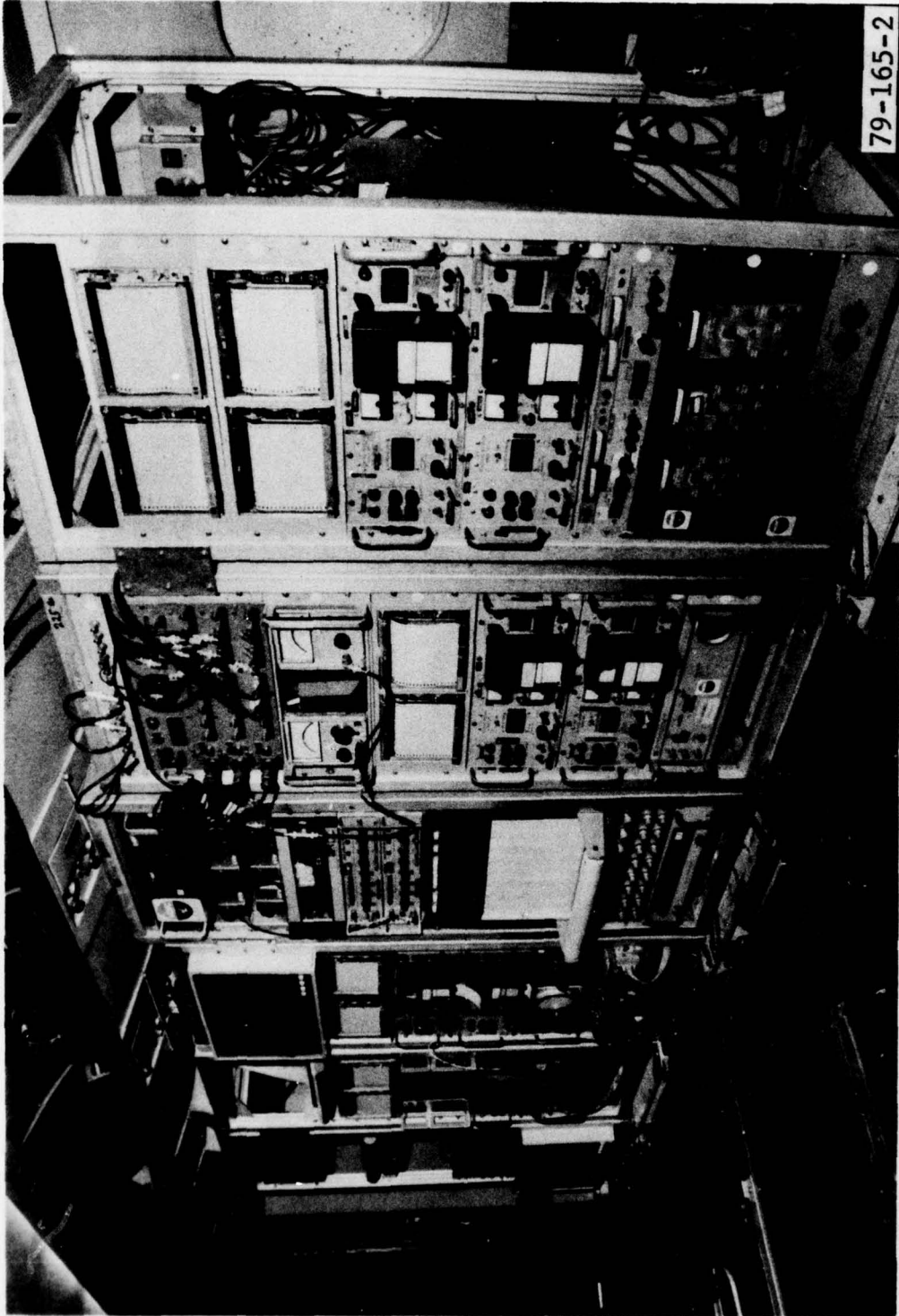

FIGURE 2. OMEGA MEASUREMENT INSTRUMENTATION INSTALLED IN CONVAIR N-42

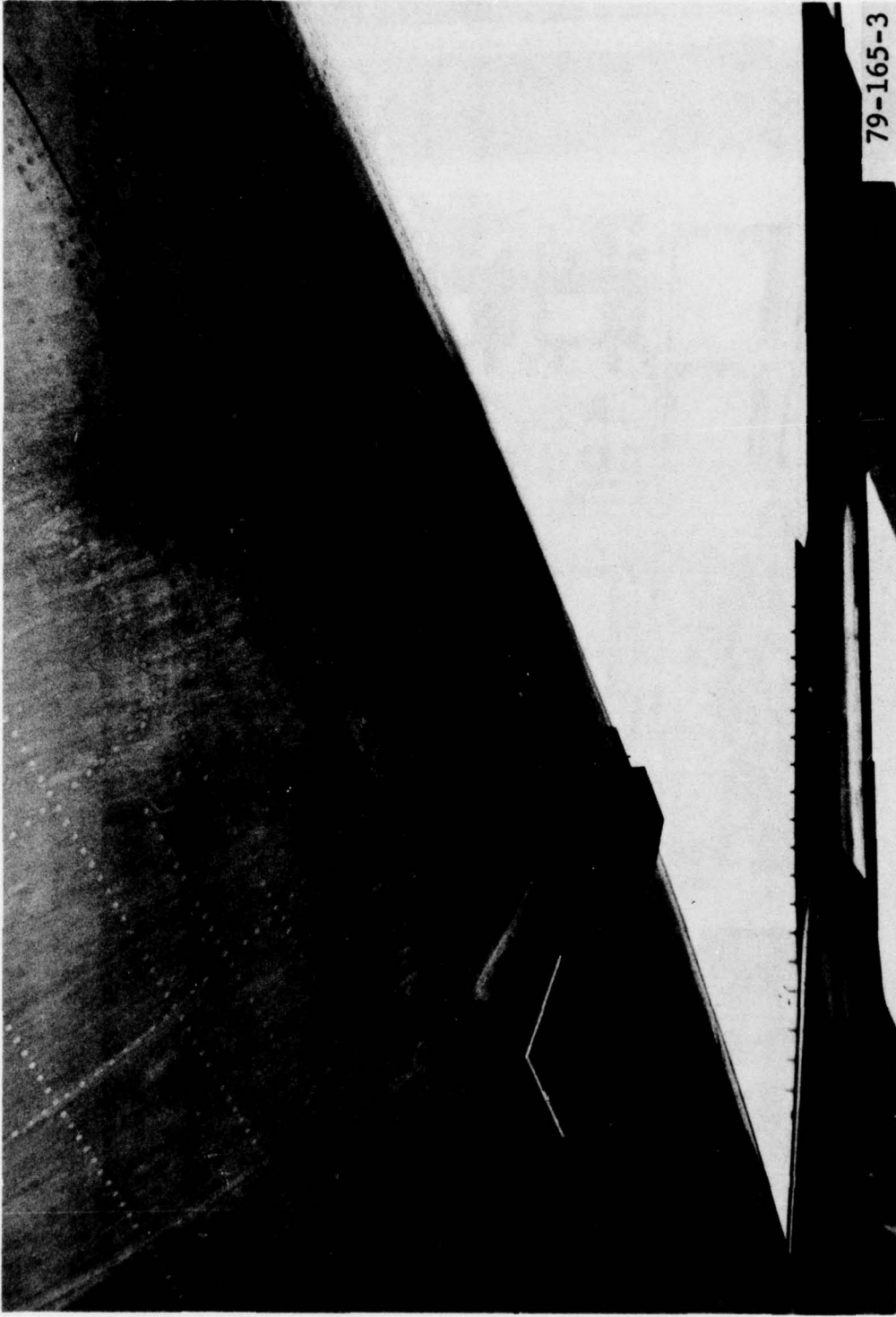

FIGURE 3. OMEGA ANTENNA FARM INSTALLED ON CONVAIR N-42

## OMEGA CERTIFICATION PROGRAMS



*Jerald M. Davis  
Federal Aviation Administration*

### BIOGRAPHY

*Mr. Jerald M. Davis is an electronics engineer on the staff of the New York Air Carrier District Office, Eastern Region, Federal Aviation Administration, where he is assistant to one of the principal operation inspectors. He received the B.S. in electrical engineering from Clemson University. He has prepared himself by study and flight observations as a technical consultant on Omega not only to inspectors holding certificates for Pan American World Airways and Trans World Airlines, but also to other offices of the Flight Standards Service of the Federal Aviation Administration.*

\*\*\*\*\*

*Thank you Joe. I fully support the need for a central data bank. We in the Air Carrier District Office probably experienced that need first. Some 18 months ago, Pan American and Trans World Airlines showed interest in certification of Omega. We had little or no knowledge of system performance. Information supplied by NAFEC and the Coast*

*Guard was especially helpful in the early stages. Every aviator wants to be confident he will be able to reach the other side once he begins to cross an ocean.*

*I welcome this opportunity to share my Omega operational experiences with you. The first question which usually comes to mind concerning Omega is: "Does it work?" The answer is: "yes." The second question is: "How well does it work?" Well, the answer to this question depends upon your perspective.*

*I notice that at least three disciplines are requested here: Research and Development (R&D), Engineering and Manufacturing, and Operations.*

*1. As you know, R&D had the difficult task of developing the basic Omega concepts and making precise measurements to validate these concepts.*

*2. Engineering and Manufacturing had the difficult task of choosing the proper compromises so that the resistors, capacitors, transistors, and integrated circuits talk to each other to produce the right answers.*

3. Now the concepts developed by R&D and the circuitry produced by Engineering and Manufacturing represent "Shear Magic" to many Operations people.

We know how to talk to the machine and how to make it talk to us. Our task is to prove that this "black box" can fly across the ocean without interfering with other air traffic in the process.

So the answer to the question: How well does it work depends on whether you:

1. Measure it with a micrometer
2. Mark it with a grease pencil
3. Or cut it with an axe.

The rest of this discussion concerns an operational viewpoint "cutting it with an axe."

From this viewpoint, the signal coverage provided by the ground-based Omega system has been good with two notable exceptions. The "Winnipeg Hole" and the Indonesian Hole." (I'll have more on these exceptions later.) I have personally observed airborne Omega performance over:

1. The North, Central, and South Atlantic
2. North, Central, and South America, and,
3. The North, Central, and South Pacific

The signal coverage in the North Atlantic has provided sufficient redundancy to continue navigation with multiple station outages. The

Atlantic coverage further improves as you proceed southward from the Greenland shadow. The example: on a daylight proving flight from Capetown, South Africa, to Rio de Janeiro, Brazil, threshold signals were received on all three frequencies from all eight Omega stations.

Although the coverage in the Pacific has not been as complete as in the Atlantic, sufficient coverage has been available east of a line from Japan to Central Australia to provide the redundancy necessary for continuous operations. The Pacific coverage is the reverse of the Atlantic coverage--the best coverage is in the North Pacific.

The signal coverage in Central and South America has been observed to be more than sufficient, even without the use of Trinidad. However, the poorest area of signal coverage encountered has been in Central North America. This area has been colorfully described as the "Winnipeg Hole," and is created primarily by the near-field constraint on North Dakota and the Greenland shadow effect on Norway.

A second important area concerns the operational accuracy of Omega equipment. This raises the question, "Accuracy relative to what?" During the Atlantic proving flights for MNPS certification, the Omega-updated Doppler positions were compared to either a corrected Inertial Navigation System (INS) position, a ground-based radar observation, or a position overhead a very high frequency omnidirectional range (VOR) or Automatic Direction Finder (ADF) gateway.

A total of 174 independent observations were obtained using two

types of Omegas. The sum of the radial position errors for their observations was 418.62 nautical miles (nmi). This equates to an average radial error of 2.4 nmi for each Omega accuracy comparison. From an operational viewpoint, this represents accuracy which is almost an order to magnitude better than Loran. Additionally, this is a higher degree of accuracy than the requirements established for Inertial Navigation Systems.

The observations obtained in the Pacific were less accurate than those in the Atlantic. This was due primarily to wider lanes which were created by longer signal paths. However, even with this complication, the average Omega radial errors observed were less than 4 nmi.

Another accuracy consideration is the frequency and magnitude of lane slips. Recent operational data obtained between June 27 and July 20, 1978 reported only one dual lane slip in 500 system flights. During this same period, 12 of the 500 system flights reported a single lane slip. It is significant to note that during this period, 360 system flights were conducted in MNPS airspace with no dual lane slips and only three (less than 1 percent) single lane slips.

Another important consideration is equipment reliability. Operational data collected since March 20, 1978 revealed 7 en route Omega failures out of 2,436 system flights. All of these failures were single failures. This operational data collection program began in December 1977 and includes reports from 2,954 system flights. During this period, we have not received a single report of a dual Omega failure en route.

So far, I've painted a fairly rosey picture for Omega. I do not mean to imply that the system is perfect. This raises the question: "What are some of the problems?"

In the initial stages of the evaluation program, several equipment problems were encountered. These included: condensation in a particular model of antenna, Receiver Processor Unit (RPU) malfunctions created by voltage fluctuations induced by heavy current loads on the electrical supply, "glitches" in the software, and malfunctions created by transients during transfer from ground-to-aircraft power. In general these problems appear to have been resolved through modifications to the affected units.

Other areas which require special consideration concern the ground-based system. The first problem area concerns deficiencies in signal coverage. Earlier, I mentioned the "Winnipeg" and "Indonesian" holes. These expressions identify two rather ill-defined areas approximately centered around Winnipeg and Indonesia. Within these areas there is a high probability that only two Omega stations will be consistently usable. The size of the holes varies with time of day, season, and small changes in signal-path attenuation. At present, dual doppler operations may be conducted within these areas due to the availability of other navigation aids. However, it is significant to note that operation within these areas may not be feasible using a sole means Omega system which does not utilize signals from the Navy's very low frequency (VLF) stations.

The Winnipeg hole's approximate dimensions are as follows:

1. The eastern boundary is a line from Sondrestrom, Greenland; through Montreal, Pittsburg, and Tulsa.

2. The northern boundary runs from Thule, Greenland; to Yellowknife, Northwest Territories, Canada; to Spokane, Washington.

3. The western and southern boundaries run from Spokane to Salt Lake City to Tulsa.

As you can see, this includes a significant portion of Central North America.

The Indonesian Hole's approximate boundaries are from Manila to Singapore to Central Australia to Eastern New Guinea and back to Manila. The Indonesian Hole should disappear when the Australian station becomes operational.

The next so called problem area concerns "lane slips." Here again, the magnitude of this problem depends upon your perspective. Operational data obtained during the past three weeks for a particular Omega installation shows 13 lane slips for 500 system flights. Only one of these lane slips affected both systems. A closer look at the geographic locations where these incidents occurred provides some interesting information. During these three week period, 360 system flights were conducted in MNPS airspace. Only three of these flights experienced lane slips. These errors were on the order of 8 to 10 nmi which is still within the MNPS 2-sigma criteria. However, the frequency of occurrence of lane slips is much higher near the geomagnetic equator. For example, the sample included 48 system flights in this region and 7 lane slips were

encountered. Also, the large majority of the dual lane slips have occurred in this region. This phenomena appears to be caused by "cycle slippage" due to intermodal conversion on the Liberia signal at sunrise.

The large majority of all lane slip errors is on the order of 8 to 10 nmi and do not represent a serious degradation in navigational accuracy, even in the North Atlantic. However, the intermodal interference on the Liberian station can present a navigational problem unless corrective measures are taken when it occurs.

Experience indicates that the Omega may continue to slip lanes unless Liberia is deselected. This means that over a period of time a significant error could accumulate. However, there is some good news. The signal coverage in the region where this problem occurs is excellent. This means that Liberia can be deselected at night and accurate navigation can still be continued.

An area which has generated much discussion and disagreement concerns the effects of solar phenomena. As you know, certain solar phenomena can theoretically affect the Omega signal's phase stability, which in turn would affect system accuracy. This issue is a "hot" topic since most airborne Omega experience has been gained during a "quite" sun. The sun is now beginning to become "active" again as we start uphill to the next solar maximum. Recent ground-based measurements have shown solar effects on the Norway signal. However, these effects have not been observed operationally. There are two probable reasons for this:

1. The majority of the ground-based observations would suggest an error of 3 to 6 nmi. This error would not normally be detectable inflight due to the absence of super accurate crosscheck.

2. The error would be "smoothed" in the computation process. This means that an error of 3 to 6 nmi on one lop may not have a significant impact when combined with four or five lines of position (lop's) which are not affected by the solar phenomena.

Until operational experience shows otherwise, I would personally suggest that deselection of stations based on solar advisories be done after careful consideration. This is an area where you need an "elephant guard." While you're busy trying to eliminate the ants, without an "elephant guard," you may be killed by an elephant stampede. What I mean to say is that you can deselect yourself out of the navigation business while trying to eliminate a 3 to 6 nmi error. It may be much more appropriate just to accept the 3 to 6 nmi "solar error" and deselect Liberia, if necessary, to prevent the "creeping" lane slips which could induce a truly significant position error.

Last, and most controversial, let's talk about the Navy VLF. I have observed Omega/VLF intermix performance throughout the Atlantic and Pacific. One of the Omega units used Omega alone and the other unit was forced into the secondary VLF mode by deselecting Omega stations. This procedure provided a direct comparison between the use of Omega alone and the use of VLF to supplement Omega. In most cases, comparisons to an onboard INS were also available. From a practical

standpoint, one system was as accurate as the other. The use of VLF to supplement Omega has several advantages:

1. The secondary mode of operation is still a position-fixing mode--not just dead reckoning.

2. In some areas, the use of VLF improves the geometry which, in turn, actually improves the navigational accuracy--in the South Pacific for example.

3. Also, the addition of VLF may provide the redundancy necessary to consistently operate in the Winnipeg and Indonesian Holes.

Each advantage also has a disadvantage. The primary disadvantage of using VLF signals is that the transmitting ground stations are not dedicated to navigation. Their primary purpose is operational communication, serving the fleet, under the control of the Navy. Therefore, there is no guarantee that the transmission format, maintenance shut-downs, and frequency would not be changed to meet defense needs. Also, some of the units using VLF do not have sophisticated propagation corrections for VLF reception, and errors could occur when the propagation conditions change.

To sum up my personal opinions on the use of VLF, I believe:

1. That the use of VLF reception for a secondary mode of operation is more accurate and reliable than dead reckoning.

2. That the redundancy provided by VLF signals increases the reliability and flexibility of the navigation system, and

3. That more extensive data concerning the accuracy and dependability of the Navy's VLF system is desirable as a means of reliably establishing its proper role in the long range navigation picture.

At this point, I would like to raise a red flag of warning to pinpoint some substantial operational differences between Omega and INS. The Omega Control Display Unit (CDU) looks very similar to that of an INS CDU and actually performs the same operations. There is a very strong tendency to treat the Omega like an INS. This attitude can cause you some real "heart burn" unless you're careful.

The INS either works or it doesn't. On the other hand, the Omega is a very independent, subtle little "critter." You can tell it exactly where it is, but it won't completely believe you. The Omega knows exactly where it is within a lane and you can't do anything to change its mind. Even when it slips a lane, it's usually very happy with what it did and has a high degree of confidence in its new position. If you instruct it to perform a Lane Ambiguity Resolution (LAR) it will dutifully go through the process and select another position. After the LAR is complete, the Omega will once again be perfectly happy with its new position even though this may be miles away from where it started.

When the "going gets tough," the Omega turns on the ambiguity light and says: "Hey boss, help me out of this mess." Unfortunately at this point, the operator can usually be of little assistance due to the absence of other external aids. If you choose to attempt a LAR, the Omega really gets confused.

It says: "Now wait just a minute, I've already told you, by turning that light on, that I don't have enough good signals to know where I am. Since that's the case, how can you expect me to do LAR." Now, if you persist with your LAR instructions, the Omega may finally "spit out" some coordinates, but don't be surprised if it places you way out in the "boondocks."

My personal recommendation for operating an Omega is to treat it like a rattlesnake. Don't play around with it unless you have to. Because if you get it confused, you may have a real problem.

Once again, we expect the data bank to prove most valuable and offer any support we can give to it.

Question (Dr. Reder) Mr. Davis, you cautioned against "fooling around" with the Omega controls. I have never seen any system with which one may safely fool around in flight.

Response (Davis) That is basically true. But, if one tries to store the wrong coordinates into an INS, it won't accept the error, but the Omega will as we have seen it in operation. One can call on the INS for any data it is capable of without losing current position. Omega is not as insensitive and can produce substantial navigational errors as a result of some cockpit operations.

Question (Lyddane) Do you feel that dual ONS offers the same reliability as dual INS now provides?

Response (Davis) There is a lot of INS history. Experience is

building rapidly on ONS. There have certainly been problems but they are looking better all the time.

Comments (Erikson) With two inertial navigation systems, you have two independent measures of position. With ONS, if signals are not arriving at the aircraft, none of the ONS equipment onboard can offer position so dual ONS can probably never equal dual INS in overall reliability.

Observation (Carmel) One can fly for quite a while in dead reckoning and still come out OK.

Response (Davis) That is true provided wind is not shifting as in the vicinity of the jet stream.

Question (Unidentified) If ONS was approved only as secondary to dual doppler or dual INS, what was the rationale for allowing dual ONS to be flown as primary means (see Advisory Circular 121-31A)?

Response (Davis) Omega was first certified only to replace LORAN-A which, at the time, was a backup to dual doppler. When ONS is applied as the sole means, the issues are substantially different.

Question (Unidentified) If general aviation can fly dual ONS as sole means under its advisory circular, I don't see why air carriers cannot do also?

Response (Scavullo) That question really should be presented to a

different group. The personnel who are competent to present the authoritative rationale behind the new advisory circulars are not present. Meanwhile, the issue you raise is not relevant to this conference. Please ask questions to help us complete our preparation for the data bank.

Response (Davis) I am not against use of Omega as sole means. Nevertheless, caution is needed because we cannot assume ONS is equivalent to INS.

Question (Unidentified) Is it not time that the many differences in characteristics of various Omega sets make it necessary to analyze data in the bank by black box type?

Response (Davis) That is true. One INS is very much the same as another, based on some physical laws. But, each type of ONS operates differently on the signals it receives. Some sets probably won't function properly in the South Pacific until the Australian station comes on the air.

Question (Unidentified) Are there any limitations due to the Greenland shadow?

Response (Davis) Highest latitude I have flown has been 65 to 66 degrees north latitude. I've heard of problems due to the shadow of Greenland. In the vicinity of Thule, coverage has been very good.

THE RESEARCH AND DEVELOPMENT PROGRAM  
FOR LONG DISTANCE NAVIGATION



George H. Quinn  
Federal Aviation Administration

BIOGRAPHY

Since 1969, Mr. George Quinn has been Program Manager for Long Range Navigation Systems in the Systems Research and Development Service. After receiving the B.S. degree in Electrical Engineering from Penn State, he was project engineer for numerous navigation system evaluations at NAFEC. He is now the sponsor of the work at NAFEC with Omega, Loran-C, Satellite, and other navigational aids. Mr. Quinn serves in the Air Navigation Group and is an active member of the International Omega Association.

\*\*\*\*\*

The surge of interest in the Omega Navigation System for aviation has brought a great deal of hope out of the investigation over a short few years. However, Omega data has been scattered; FAA had some, Pat Reynolds of Pan American had some, Coast Guard had some, and it was not possible to correlate one batch with another. Both the operators using Omega and the FAA lack experience with the system. There had been no clear picture available showing how the Omega signals would be affected

over the complete routes to be flown during the upcoming solar cycle. For these reasons, we undertook two basic activities. The first was to establish an Omega data collection project and a data bank at NAFEC, Atlantic City, N.J. It would encompass automatic collection at a high sampling rate as an improvement over the hand-copied method so prevalent elsewhere.

A central point was needed, not only for data collection but also for reduction, analysis, and reporting on a quarterly or monthly basis. The second major project undertaken at the request of the Flight Standards Service of FAA was an Omega system advisory service.

The Omega data bank was started in order to take advantage of production models of Omega receivers as they are actually installed in the air carrier fleet. There seemed little chance of collecting worthwhile data by any other way since our principal need is for information about Omega along operational over-water routes and especially during the upcoming maximum of solar activity which may extend over one or more years. We must establish the significance of

the solar activity. If it does not affect navigation during this solar maximum, Omega may be able to ignore it in the future.

It is our plan to provide recorders and tapes, fund the nonrecurring costs to develop the initial interfaces, establish the data bank at NAFEC, and issue reports.

In aviation, the Notice to Airmen (NOTAM) service is well known. The Research and Development Service of the FAA has no responsibility for issuing NOTAMS. But, it will develop the equipment and the system for reporting Omega system status via the NOTAM service. It will provide real-time advisories on signal conditions and messages worded to meet operational rather than scientific needs. Dr. Levine's presentation will have described this development in some detail.

We seek the real-time monitor because we see the need to provide, if possible, automatic advisories on Omega and VLF signals. The system will have to analyze propagation and phase anomalies based on received signals, incorporate administrative information such as forecasted station shut-downs, reported outages, and use information from the "PROPHET" system to be described by Dr. Levine. Consideration of incorporating inputs from the "SOLRAD" system has been discontinued.

Status of this program as of August 1978 is as follows: 20 digital recorders and compatible tape cassettes have been procured, orders have been placed for modification kits for all the production Omega sets to interface these sets with the recorders, organization of the

data bank has begun at NAFEC, and formal invitations for participation in this data bank have been sent to major U.S. air carriers. The prototype advisory monitor has operated consistently at NAFEC on Omega reception. By next June, it will have been modified to operate also on VLF signals.

Participation in the Omega data bank involves installation of the FAA recorders in the user's aircraft. Users will arrange to install the Omega interface modification kits and aircraft wiring to the recorder. Only a limited number of modification kits have been funded at present.

Participants in the data bank will operate the Omega receiver-recorder combination on regular flights only. Regular ground crew personnel will install and remove tape cassettes so that flight crews will have no tape-handling duties. Cassettes are to be mailed regularly to NAFEC, the source of new cassettes. Participants will be asked to help plan and adjust the format of reported results so as to make reports most useful to them.

Participation by users in the Omega VLF advisory service project is limited to advice. We need to know whether all the available information should be presented, how, in what format, to what criteria, as related to operational needs. Helicopter operators may have different needs from those of the oceanic operators. With timely inputs from potential users, our designs may be refined.

A number of benefits will be derived from the data bank reports. But, participants will have to advise NAFEC how they want to have the

information presented. For one thing, you may learn from the bank how the experience of different operators with different avionics and different aircraft or installations compare along the same oceanic routes. Documented performance of Omega routes you are

considering may well suffice to support your decision about route selection.

Benefits of a realistic advisory service are expected to show up both as increased efficiency and lower risks in long-distance flight operations.

MANAGEMENT OF THE OMEGA  
NAVIGATION SYSTEM



David C. Scull  
United States Coast Guard

BIOGRAPHY

Mr. David C. Scull is Chief of the Navigational Sciences Branch of ONSOD. He was awarded the B.S. in Geology and Mineralogy by Penn State and the M.S. in Systems Management by U.S.C. His career included geophysical and geodetic investigations with the U.S. Hydrographic Office and the Naval Oceanographic Office. Concern with electronic positioning systems led him to management of development work with Loran, Omega, and satellite navigation systems. He holds an instrument rating to fly aircraft. He is Secretary to the Radio Navigation Committee of ION and an active member of the International Omega Association.

\*\*\*\*\*

ONSOD contains some 20 persons under leadership of a commanding officer who is a former C-130 pilot. A Commander in the U.S. Coast Guard, he is very interested in aviation uses of Omega. In a few weeks, he will be secretary to an Radio Technical Commission for Aeronautics (RTCA) committee to update the minimum performance specifications for Omega receivers.

Within ONSOD, the Engineering Branch is responsible for the system hardware of the transmitting-station network and the monitor-receiver network. The Navigational Science Branch, of which I am chief, handles software with the efforts of eight navigational scientists, mathematicians, and computer technicians. Both branches keep an intimate software-hardware interface.

As for the present status of the Omega Navigation System, Station A, located at Aldra, Norway, is off the air for extensive antenna maintenance. The antenna, which is the valley-span type (figure 4), is being raised so it can radiate a full 10 kW. The change will not be dramatic, but fringe areas will be filled in for better performance. The Norwegian Telecommunications Administration operates Station A. At Monrovia, Liberia, the Ford Aerospace and Communications Corporation operates Station B under contract in conjunction with the Liberian Department of Commerce, Industry, and Transportation. In the future, native Liberians will take over operation. Station C at Haiku, Hawaii and Station D in La Moure, North Dakota are both operated by

U.S. Coast Guard personnel. Station E, operated by the French Navy at La Reunion Island in the Indian Ocean, has been giving excellent service. Station F, located at Golfo Nuevo, Argentina, is operated by that country's Hydrographic Service at high efficiency. Station G, located on Trinidad Island, is temporary. It has been operated under contract for many years. Its coverage of the North Atlantic has been most useful, but it will have to go someday. Table 1 lists the antenna types at the several stations. Most of these antennas are more than 1,200 feet high.

Until the Australian station has been placed in operation, Trinidad will probably be allowed to continue to serve the North Atlantic route. Meanwhile, signals from Trinidad, in part, compensate for absence of other signals in the so-called Winnipeg Hole. Spare parts are available to keep Trinidad operating through 1980. A design-review meeting with the Australian Department of Transport was completed in July. The civil aviation personnel of that Department will be operating Australian transmitting Station G. Ground has been cleared, borings taken, all ground site preparations completed, and fiscal arrangements established. Construction will begin in October 1978. By June 1980, Omega Station G should be in operation.

Omega system status reports (table 2) are now being disseminated in a number of ways. Broadcasts via WWV and WWVH contain data and operational warnings. Argentina, Japan, and Norway issue broadcasts to mariners on various frequencies. A direct communications link connects ONSOD with the National Flight Data

Center which supplies the NOTAM circuits to all the major airports of the world. For the mariner, the HYDROPAC and HYDROLANT message system conveys the special ONS system status messages which contain details of recent past history such as off-air times. Telex and regular mail distribution is also available.

The mission of ONSOD includes not only operation of the transmission network, but also the coordination with other countries under bilateral agreements with the United States. It is sometimes necessary to accede to wishes of partner countries, but control by ONSOD is generally acknowledged. Operating spares are stocked in our supply center in Brooklyn, New York, and distributed to all stations as needed.

Most important at this time is the effort of ONSOD to calibrate the Omega Navigation System. We are trying to put the fine graduations on the "Omega meter bar," but as yet, we can only identify the larger divisions. On July 3, 1978, the Commandant of the Coast Guard assumed full responsibility for the System from the U.S. Navy. By 1980, the U.S. Department of Transportation will have complete authority for the system, thus Omega will be transposed from a military system with civilian applications to a civil navigation system. (NOTE: The Federal Aviation Administration and the U.S. Coast Guard are organizations within the U.S. Department of Transportation.)

Responsibility for system calibration begins when the signal is transmitted. Signal must be monitored for characteristic coverage and accuracy. Accuracy is related to phase stability. With a correct

propagation model, we can predict signal behavior. At present, predictions for some areas are not yet correlated with observations. Some discrepancies are large and some small.

One propagation model in wide use by manufacturers contains some 13 geophysical forms, each of which is influenced by day and night coefficients which are not completely refined. We are obliged to take observations and force fit some theoretical equations into the real world observed by a monitor network. Corrections, published by the Defense Mapping Agency based on data supplied by ONSOD, are furnished to the navigator aboard ship. The several different designs of automated airborne receivers now in service could incorporate different propagation models, and correction changes can be introduced only with software modification at the factory. Meanwhile, within the government, the Coast Guard and the FAA do not know what these different propagation models are as we have no way of controlling the design of the avionics. We do, however, disseminate basic information which ought to be considered by the designers.

The monitor system, now planned, will be based on 60 receivers to give us the optimum spatial coverage. Of course some interpolation will be needed. Many of the monitor sites (figure 5) are now being prepared in a world-wide cooperative program. It is taking some time to work out agreements. A few parts of the world can only be monitored from islands which are not on major air and sea routes, are very inaccessible, and may have power only part of the time. Thus, the establishment

of some stations is not entirely simple. The Soviet Union and China are not yet offering sites for monitors, but some discussion of these possibilities has taken place. Meanwhile, the vast areas of those countries are not covered by the ONSOD monitor network.

The chief goal of the network is to formulate and refine the phase prediction model from which corrections can be generated to sustain the accuracy of Omega for both mariners and airmen. In some areas where problems are rated by concentration on monitored signals, adjustments for the propagation model can be based on the empirical data. Omega also is available as a means of time dissemination. While the network will be sufficient for development of a model for world-wide phase prediction, it will not disclose all the coverage gaps. As already mentioned, over broad expanses, there is no way to operate the monitors. Thus, the FAA's program is very important to supplement ONSOD's work with the fixed monitors.

As part of the Omega validation effort, special signal measurements are made. The monitor equipment has included the TRACOR Model 599R receiver which can be calibrated to give absolute values of field strength, but it is limited to four channels. It is configured as an analog sensor which produces data which are cumbersome. A newer receiver produced by Magnavox embodies state-of-the-art micro-processor technology and senses three frequencies currently from each of eight transmitters. Data are recorded at selected intervals on magnetic tape cassettes, much of it at monitors located in

countries other than the United States. Data from France is received on punched paper tape; Argentina supplies punched cards and coding sheets. The large volume will grow as the number of active monitors increases. Our plan is to put this data in master files on magnetic tape, making it available to scientific and engineering users. Monitoring is expected to confirm the estimates of disturbance phenomena tabulated in table 3.

A major program effort is to validate the system on a regional basis. Fixed monitor stations, surface ships, and aircraft are engaged in the measurements. Difficult problems of anomalous propagation and modal interference must be studied by flying radial paths on great circles which pass through transmitter sites. Aircraft alone can traverse such a path in a reasonably short time. This year the Convair 880 aircraft based at NAFEC is covering the North Atlantic Ocean area. Processed data will lead to a statement by the Coast Guard in the form of a NOTAM and a description in the Airman's Information Manual portraying the capabilities and limitations of Omega in a particular geographic area. Similar information will be available to the marine community. A list of stations available and useful on a 24-hour basis will be especially valuable to mariners and backup stations also will be indicated. A contractor has been engaged to incorporate both scientific and operational data into a report which describes results of the validation effort and is readable and meaningful for a wide variety of interests. The report of initial validation tests in the Western Pacific area probably will be released in the near future. Figure 6 illustrates the dissemination

route established for Omega validation data.

New tables, improved corrections, and refined models will be released on a continuing basis as each area of the world has been examined. In 1977 a preliminary statement was released as a result of the initial validation tests. The absence of a transmitter in Australia has precluded achievement of our accuracy design goal of 2 to 4 nmi en route navigation 95 percent of the time. Fixed monitors indicate errors of 5 to 6 nmi in most of the Pacific Ocean area. While Loran-A has been phased out in the North Atlantic, there was considerable background of Omega test data. The Loran-A shutdown in the Western Pacific made urgent our validation in that area. In 1978, FAA is helping us in the North Atlantic. In 1979, the North Pacific area will be examined. In subsequent years, we will cover the South Atlantic, South Pacific, and Indian Ocean areas.

Solar activity has been noted to cause phase offsets resulting from proton effects. The large portion of sudden ionospheric disturbances (SID) appear to be so short (less than 30 minutes) that most navigators can handle them. Direct effects on navigation seem to be tolerable. At Boulder, Colorado, the Environmental Data Center was advised that its reports of solar events have not been found closely correlated to navigation difficulties. Now ONSOD will supply monitor data to the Center for its examination.

In summary, it is clear that by combining information derived from efforts in many parts of the world, there are very interesting possibilities for perfecting not only Omega, but other systems or services.

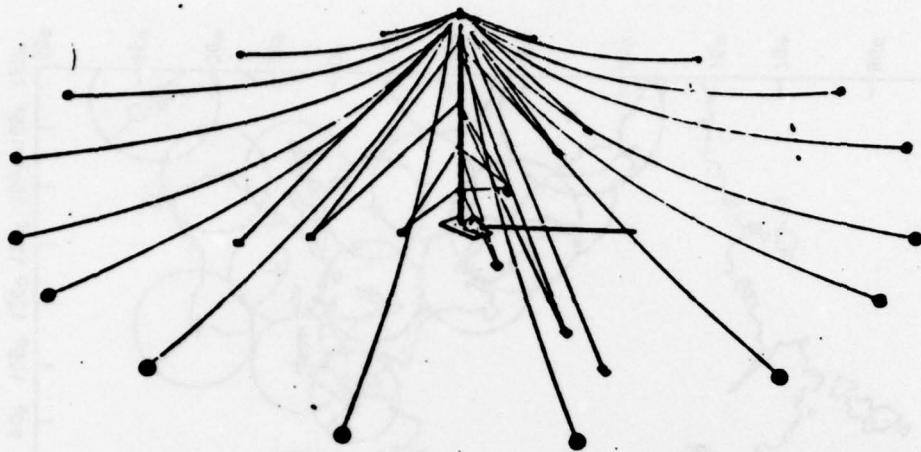

**UMBRELLA ANTENNA**

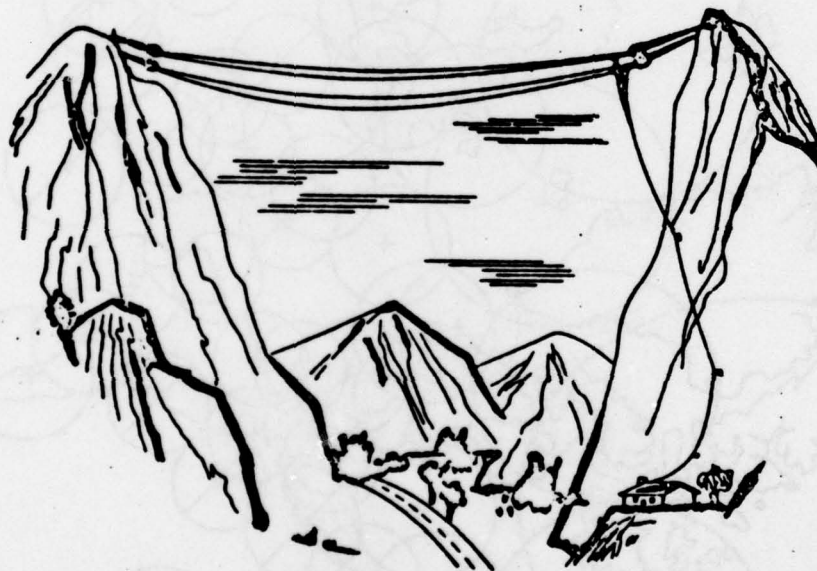

**VALLEY-SPAN ANTENNA**

79-165-4

**FIGURE 4. PRINCIPAL TYPES OF OMEGA TRANSMITTING ANTENNAS**

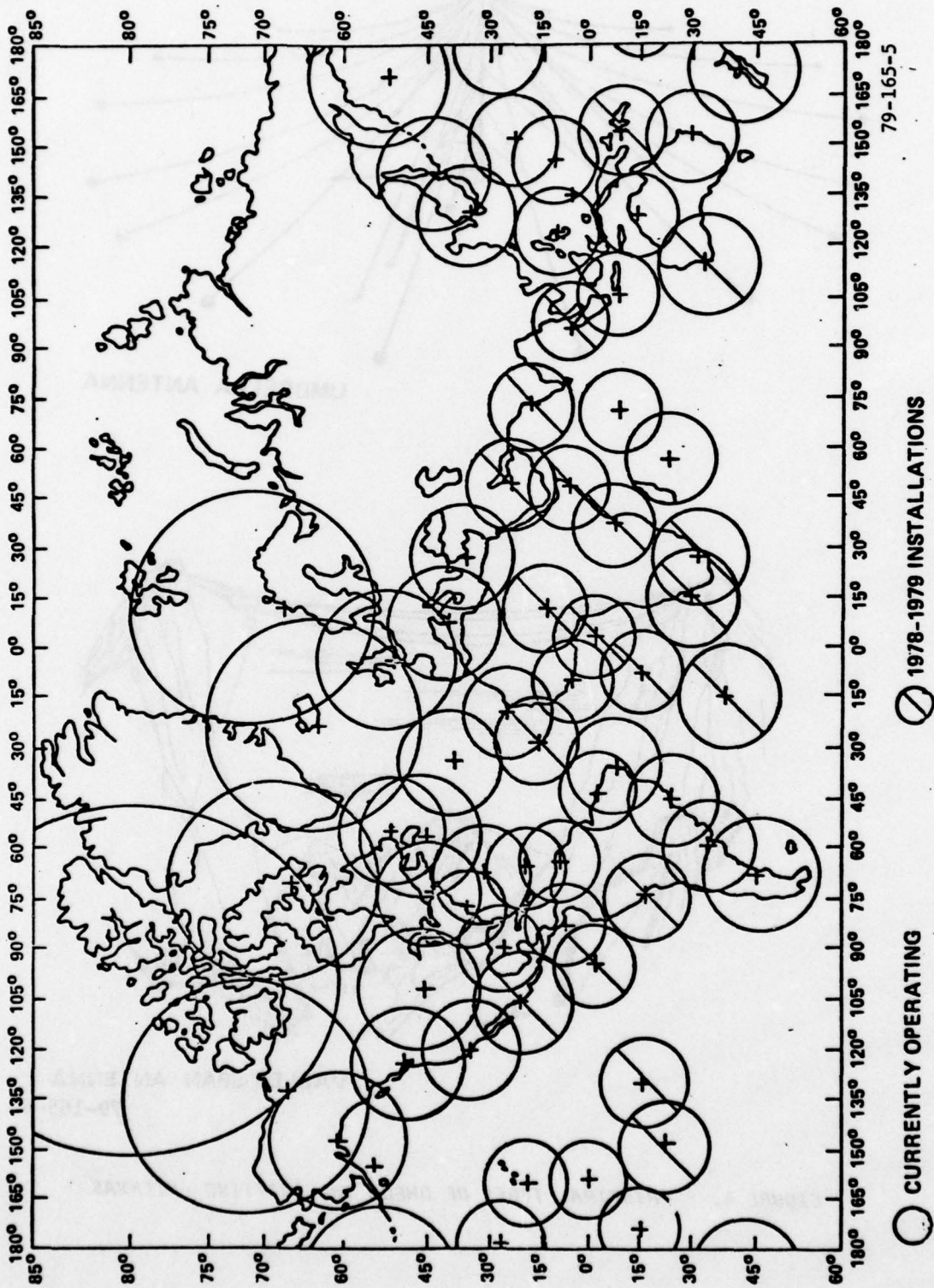

FIGURE 5. PROPOSED WORLD-WIDE DISTRIBUTION OF OMEGA MONITOR SITES

**Sources of Scientific Data**

- Permanent Monitor Sites
- Short-Term Fixed Monitor Sites
- Airborne Monitor Equipment
- Shipborne Monitor Equipment

**Sources of Operational Data**

- Airborne OMEGA Navigation Equip.
- Shipboard OMEGA Navigation Equip.

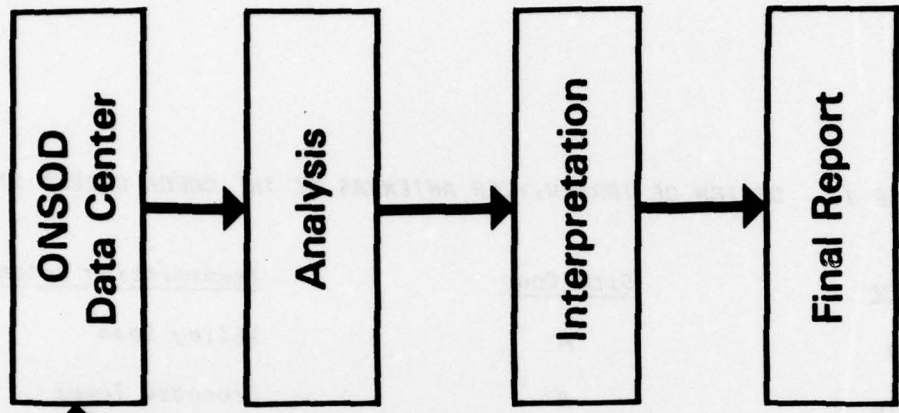

79-165-6

FIGURE 6. FLOW CHART FOR OMEGA SYSTEM VALIDATION DATA

**TABLE 1. DESIGN OF TRANSMITTER ANTENNAS AT THE OMEGA GROUND STATIONS**

<u>Country</u>	<u>Site Code</u>	<u>Transmitting Antenna Design</u>
Norway	A	Valley Span
Liberia	B	Grounded Tower
Trinidad	B	Valley Span
Hawaii	C	Valley Span
North Dakota	D	Insulated Tower
La Reunion	E	Grounded Tower
Argentina	F	Insulated Tower
Australia	G	Grounded Tower (Probable)
Japan	H	Insulated Cylindrical Tower

TABLE 2. DISSEMINATION OF OMEGA STATUS REPORTS

<u>Origin Of Omega Status Reports</u>	<u>Recipient Agencies</u>	<u>Dissemination Method</u>
Omega Navigation System Operations Detail, U.S. Coast Guard, Washington, D.C.	National Bureau of Standards	Radio Broadcast over stations WWV and WWVH
	National Flight Data Center, Federal Aviation Administration	Notices To Airmen
	Department of Defense, U.S. Navy	HYDROLANT and HYDROPAC Message Systems
	Department of Commerce, Maritime Administration	Notice To Mariners
	Various Government Users	AIG 8980
	Civilian Users	TELEX TWX Mail Code-A-Phone

TABLE 3. PHENOMENA CAPABLE OF DISTURBING OMEGA SIGNAL PROPAGATION

<u>Phenomenon #</u>	<u>Cause</u>	<u>Line of Position (LOP) Shift (nmi)</u>	<u>Expected Duration</u>	<u>Expected Frequency Of Occurrence</u>
Suden Ionospheric Disturbance (SID)	Solar Flares	1 to 2	Less than one hour	7 to 10 per month*
Polar Cap Absorption (PCA)	Solar Proton Emissions	6 to 8	2 to 3 days	6 per year*

# Work is necessary for development  
of prediction/circumvention  
techniques

\* Pertains to a quiet  
sun, summer month

## EVALUATION OF OMEGA PROPAGATION MODELS



*Peter B. Morris  
United States Coast Guard*

### BIOGRAPHY

Mr. Peter B. Morris is a navigational scientist in the U.S. Coast Guard's Omega Navigation System Operations Detail. He received the B.S. in Engineering Physics from Lehigh University and the M.S. in Physics from Syracuse University. While at Rome Air Development Center, he was engaged for several years in the analytical modeling of electronic defense systems. For the past 5 years, he has directed the design of the Omega Validation Program, making major contributions to the refinement and perfection of the propagation model for the Omega Navigation System. He is now a candidate for the Doctor of Philosophy degree in Physics at the University of Maryland.

\*\*\*\*\*

A mathematical model of world-wide Omega signal propagation is the basis for predicting and preparing coverage diagrams. These, in turn, are applied to the design of receiving and computing systems for Omega navigation.

In order to understand coverage diagrams, a few concepts are

necessary. Omega is a successful navigation system because the phase of the received signals is very nearly linearly related to distance from the transmitting station, while amplitude decreases exponentially with increasing distance. Anomalies, both spatial and temporal, involve departures from a normal relationship where the signals do not behave as expected. In the auroral zone and polar-cap region, the effects of particle showers are prevalent. Sudden phase anomalies occur only over portions of the earth illuminated by the sun while polar-cap disturbances occur along trans-polar paths.

An effect due to the sphericity of the earth is the focusing of signals near the antipodes. For example, signals from Japan are refocused near Argentina. Antipodal interference occurs when the strengths of two received signals are comparable after both have traveled to a receiver in opposite directions around the earth. Usually one of the paths is considerably shorter since it attenuates a signal much more than its opposite. Reception of signals via the longer of the

two "great circle" propagation paths is not uncommon. For example, the antipode of La Reunion is just off the coast of Baja, California, and in the Eastern U.S., we measure La Reunion signals arriving from the west.

Propagation irregularities are now lumped under the heading, "modal interference" for the purposes of signal prediction. Successful prediction to date has been based on the concept of a spherical waveguide between earth and ionosphere. Spatial modal interference occurs at generally predictable places in the waveguide. Modal conversion, predominantly a temporal effect, occurs when propagation crosses either the day/night or the night/day transition. The effect varies according to the angle of the crossing and the time of exposure to it. A dominant daytime mode is replaced by one or several other nighttime modes. Modal degeneracy, a fairly large effect, occurs over a rather narrow range of conditions along trans-equatorial paths.

Atmospheric noise in the very low frequency spectrum is another important factor pertaining to signal reception and, hence, to coverage. Observational experience in Omega work has shown that noise predictions according to the model of the Comité Consultatif Internationale Radio (CCIR) are not entirely satisfactory. We now use what is called the Westinghouse-Naval Research Laboratory or Maxwell (reference 1) noise model which supports prediction by frequency, time, and date. The model gives us the expected median noise for a 100 Hz bandwidth.

A full-wave model, based on Budden's full-wave formalism (reference 2) and extended by Pappert (reference 3) will provide accurate signal strength and phase behavior predictions. The model does not predict absolute phase, which the navigator needs. The famous Swanson PPC model (reference 4) is still relied upon for prediction of phase corrections. The semi-empirical, equivalent single-mode model is used while planning validation flight tests. The amplitude model now under development will help in defining coverage in search and rescue, etc.

Swanson's semi-empirical PPC model has been programmed into many airborne receiver systems, usually with some modification. Phase is modeled in terms of important geophysical variables, including magnetic field, diurnal variation, ground conductivity, excitation factor, etc. Paths are broken up into segments with near-homogeneous character within three distinct regions: excitation, midpath, and deexcitation. Full-wave studies now seek to determine how phase depends upon each parametric variable. Functions are approximated, and uncertainty is accounted for by introduction of regression coefficients, for both day and night conditions.

Any semiempirical model has to be responsive to the input data. Phase-difference data is easier to measure and, hence, accounts for a large fraction of the total data base. When signal data are available which are sufficiently numerous and diverse in terms of the geophysical parameters of the actual propagation medium, new regression coefficients are derived for

distribution to the Defense Mapping and Hydrographic Topographic Center and to the Omega community. Since 1971, new coefficients have been obtained for only a limited area of the globe and only for transmitting stations in the northern geomagnetic hemisphere. The PPC model is readily incorporated into a navigational microcomputer; errors of 5 to 10 centicycles are to be expected. That model is global in scope, only contains the first mode propagation, and it is less reliable where monitored data are sparse. PPC's are available either directly, as tables, or indirectly as a set of algorithms from which the values may be computed.

The amplitude model, based on real data, is being developed parallel to the development of the phase model. Signal-to-noise ratio is the basic measurement used as input to the amplitude model. Noise common to two channels is removed by dividing the signal-to-noise ratio of one channel by that of the other. The result is that amplitude differences in decibels (dB) can be used as input to the amplitude model which can be the basis for computing optimal model coefficients. A model with more accurate coefficients can then be incorporated into coverage diagrams. Figure 7 illustrates the main features of Omega propagation medium on which the various models are based.

Because large phase excursions may be incurred, modal interference, which takes several forms (table 4), precludes application of the phase correction model in those regions where the coverage diagrams lead us to expect it. Modal interference is defined as the presence

at the receiver of two or more strong-amplitude modes of the propagated signal. Variations with distance are typically either quasi-periodic or, sometimes, random.

Sudden changes in conductivity of the earth, as at the boundary between seawater and freshwater ice in Greenland, can cause spatial modal conversion which is measureable (figure 8). In daytime, behavior of the propagation medium is linear.

Mode II (the second "TM" Mode) is attenuated more than Mode I. Mode I is defined as the mode with the lowest phase velocity. Also, the daytime far-field excitation factor is generally higher for Mode I. At night, on the path from Hawaii to Guam, attenuation of Mode II is only slightly greater than attenuation of Mode I. Excitation factor for Mode I is less than that for Mode II so that Mode II prevails at the receiver when close to the transmitter or within 2 to 5 megameters. Full-wave calculations compare well with empirical data. Eventually Mode II dies off and modal interference disappears. During the Western Pacific validation test (figure 9), measurements on flights between Japan, Clark Air Force Base in the Phillipines, and Djakarta, Indonesia, nulls actually observed were as predicted within 50 nmi. A calibrated receiver, carried as part of the special onboard instrumentation, did not track at these predicted deep nulls. Modal conversion at the day/night terminator may lead to cycle slipping.

Modal degeneracy (figure 10) occurs on transequatorial propagation paths from transmitters in the northern hemisphere along azimuth

angles from  $180^\circ$  to  $210^\circ$ . This phenomenon may be explained by noting that when two modes reach the receiver together, their characteristics effectively are exchanged, more or less, at random intervals under nighttime conditions. Under some propagation conditions, modes only approach degeneracy; under others, they pass the point of degeneracy.

Modal interference does not occur along all paths; its extent over daylight paths may become negligible as near to the transmitter as 300 kilometers (km) or as far as 1000 km. At night, modal interference patterns are generally aligned easterly and westerly. The stations in northern latitudes, such as Norway, do not exhibit modal interference beyond the "near-field" region in daylight; only in the near-field are difficulties encountered. Along night paths where modal interference is absent, signals travel to great distances even beyond the antipodes. However, the world is never more than half dark.

Signal-to-noise ratios of -20 dB (100 kHz bandwidth) are taken as a lower threshold for plotting coverage diagrams. Early equipment was considered incapable of tracking at lower signal-to-noise ratios. Coverage predictions using a lower signal-to-noise ratio threshold of -30 dB show very significant extension of possibilities for navigation with Omega signals.

A criterion has been established for phase stability to indicate the onset of modal interference. The criterion selected was that the total signal phase excursion (over-the-path distance) from that of the dominant mode be less than 13 centicycles. In the regions of modal interference,

navigation is degraded in quality but not necessarily precluded. The fourth mode on the 10.2 kHz signal from Liberia is dominant in South America. Where a higher-order mode is dominant, that region should be excluded from coverage. Also to be excluded are areas in which there are poor geometric relationships with stations being received.

The basic idea of a coverage diagram is to portray the distribution of useable Omega signals geographically. But, both signals and noise are functions of space and time. A geographical plot is not conducive to portrayal of the time dimension. Clearly, coverage diagrams cannot provide for every hour of every day of a year. Instead, signal amplitude, signal phase, and median noise amplitudes are computed for 8 to 16 radial paths from each transmitting station for both local summer noon and local winter midnight conditions; threshold points are then located and a boundary contour developed by connecting the threshold points. Although some radial paths cross terminators, a reasonably good mode-conversion model has been developed to perform the calculations. Once the geographical coverage of each station has been plotted, a composite coverage diagram is developed by overlaying all of them.

The temporal component could have been eliminated by averaging values over a number of samples taken at regular global time intervals. Also, one could anticipate extreme conditions for a fixed local time. Another technique is to present the percentiles which show what percentage of the time a given path is covered or not covered. Most work has been focused on local

summer noon and local winter midnight conditions. At local summer noon, we expect noise to be highest and signal to be most attenuated so we expect the least range. At local winter midnight, we expect noise to be low and signal to be high, but modal interference becomes dominant. These two conditions are believed to be roughly indicative of Omega coverage 10 to 20 percent of the time.

An earlier coverage diagram contained the geometry criterion that the root-mean-square (RMS) radial error be less than 1 km per centicycle of RMS phase error. One coverage diagram was produced under the criterion, perhaps the most stringent, that signals be accessible for both local summer noon and local winter midnight.

Nighttime modal interference on the Norway 10.2 kHz signal is restricted to the near-field region. The pattern of modal interference from Liberia includes fourth-mode reception at 10.2 kHz in South America. The nighttime 10.2 kHz modal interference zone for Hawaii extends to the west and southwest.

At its high geomagnetic latitude, North Dakota does exhibit only nominal modal interference on nighttime 10.2 kHz signals. La Reunion produces stable long-path signals in the daytime in the U.S. and Northern Atlantic, while its short-path signal exhibits modal interference in this region during local nighttime. Like La Reunion, Australia will provide extremely long-range signals when it goes on-air. Nighttime modal degeneracy on the Argentina signal is found in a region west from a line that runs north from Argentina through Phila-

delphia and Ottawa. Argentina is available at 10.2 kHz via the long path to Japan and other distant points in the North Pacific.

When degeneracy occurs, it is devastating, but its occurrence depends on the nighttime ionosphere. Australian modal patterns will be similar to those from La Reunion. The Western Pacific validation showed modal interference along the path from Tsushima to Clark and also to Jakarta.

The lower threshold signal-to-noise ratio for acceptable signals is -20 dB (100 Hz bandwidth). LSN is the abbreviation for local summer noon, and LWM is for local winter midnight and PSMI stands for possible significant modal interference. Contours of the coverage diagrams, of course, can be overlaid to show what signals are available from each transmitter. From these, the composite world coverage is developed.

Some of the results to date of the July 1978 Atlantic/Caribbean validation tests are already available. Tests are conducted in places where signals are apt to be marginal and in those regions most important to navigation. Measurements are compared with predictions and then extrapolations are carried to other regions. Observed nulls are generally located as predicted even though their depth is less well correlated. Of course, receivers will fail where the signal nulls occur since noise will usually persist at a steady level. Perhaps the best prediction tool is the full-wave/waveguide-mode model. Most often the CCIR noise or the Westinghouse noise contours, as published for various Greenwich Mean Times, are also applied.

The routes followed in the Convair CV-880 aircraft emphasized adjacent great-circle radials from Argentina and Liberia during a set of seven night flights.

At Puerto Rico, a temporary monitor showed that Norway is receivable on 10.2 and 13.6 kHz at about 40 dB in signal strength, a signal-to-noise ratio of about 5 dB. Liberia was good in daytime, especially at 13.6 kHz, but modal interference and mode conversion produced SNR nulls at 13.6 kHz to -20 dB while 10.2 kHz was found without nulls but generally weak.

The 13.6 kHz signal from Argentina at Puerto Rico was good both day and night; where the predictions show nighttime degeneracy just to the west of Puerto Rico at 10.2 kHz, the signal was down -30 dB at night. Japan was received adequately at the Puerto Rico monitor even at -15 to -20 dB. On a run to the east of Puerto Rico, the Argentina signals were good. The radial from Liberia to Merida in the Yucatan contained no nulls despite a few instabilities. On the Puerto Rico to Bermuda path, 13.6 kHz was fine, but the 10.2 kHz frequency from Liberia was poor and resulted in cycle slipping. At Bermuda, the Japan 10.2 kHz signal was received better than 10.2 kHz from Argentina; Norway was good, and 10.2 kHz from Liberia was good while Argentina produced weak signals. At NAFEC, there were no signal losses, but noise contaminated the reception.

The second portion of the validation mission is planned to follow the routing which connects Atlantic City with Gander, Newfoundland; Lajes in the Azores; Keflavik, Iceland; Bodø, Norway; Rota, Spain; Monrovia, Liberia; Recife, Brazil; and the Cape

Verde Islands. One path, from Monrovia to Natal, is almost coincident with the geomagnetic equator. The courses were selected to answer the most urgent questions about the extent of modal interference, low signal-to-noise ratio, and long-path signal behavior in the Northern Atlantic region.

To summarize, the following statements may be made:

Optimum performance is predicated on all the Omega transmitting frequencies arriving via a single dominant mode at all points of reception around the world.

A single dominant mode is observed along all day-propagation paths outside the near-field region (1000 km radius from a transmitter).

Modal dominance is not observed along paths of night propagation over certain azimuth angles from transmitters situated at low latitudes.

Global coverage is practically complete, despite less than perfect propagation because:

- propagation arrives via dominant modes along both day and night paths from transmitting stations situated at higher latitudes.

- propagation of signals at night extends to great distances via paths at azimuths favoring single dominant modes.

- day signals propagate via single dominant modes.

- no more than half the earth is ever in darkness.

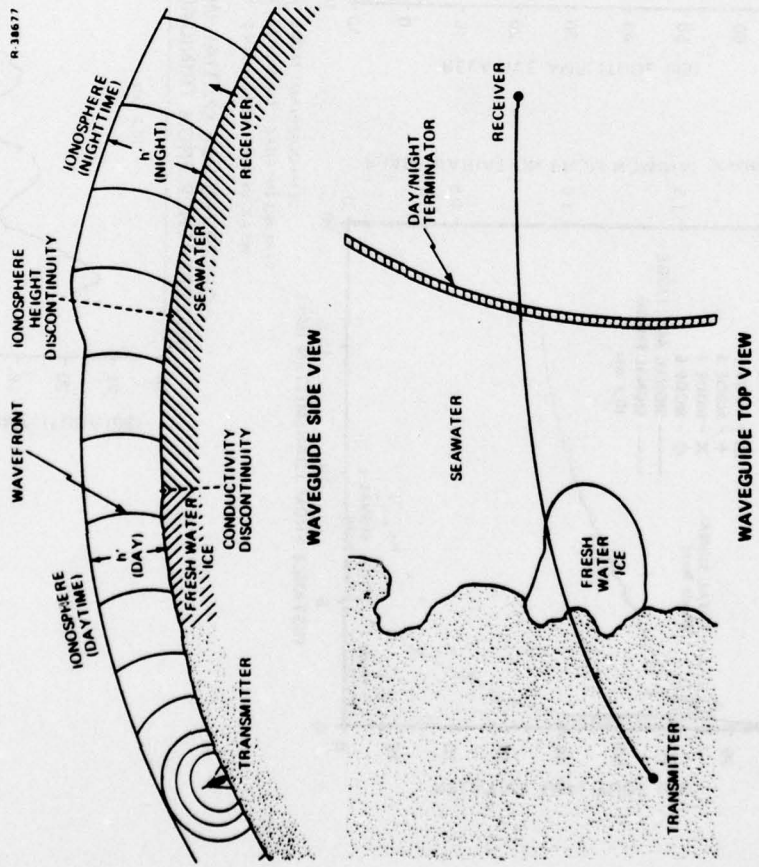

R-38677

**BOUNDARY CONDITIONS**

**EARTH'S SURFACE (Lower Boundary)**

- CHARACTERIZED BY THE GROUND CONDUCTIVITY ( $10^{-6}$  TO 4 mhos/m)

**IONOSPHERE (D-REGION) (Upper Boundary)**

- A WEAKLY IONIZED MEDIUM CHARACTERIZED PRIMARILY BY FREE ELECTRONS
- EFFECTIVE REFLECTION HEIGHT
  - 70 - 75 km FOR DAY
  - 85 - 90 km FOR NIGHT
- ANISOTROPIC DUE TO GEOMAGNETIC FIELD

79-165-7

FIGURE 7. THE EARTH--IONOSPHERE WAVEGUIDE

THEORETICAL PREDICTIONS SHOWING MODERATE INTERFERENCE ALONG SOUTHEAST PATH FROM NORWAY STATION

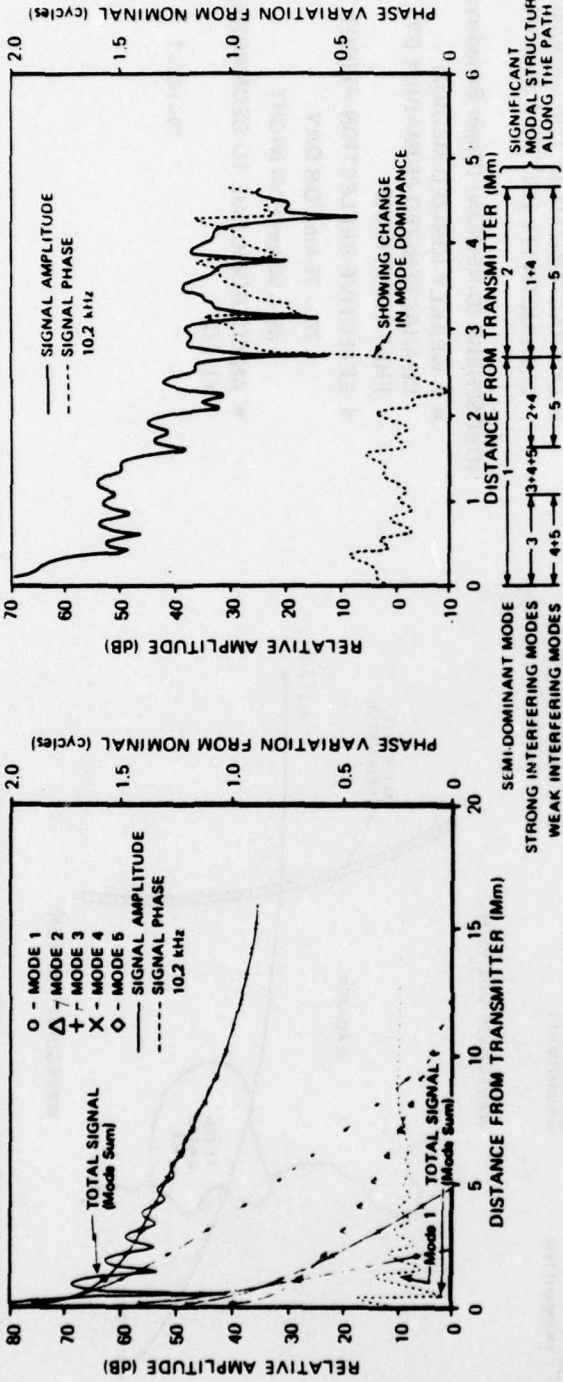

THEORETICAL PREDICTIONS SHOWING SEVERE INTERFERENCE FROM JAPAN STATION TO SINGAPORE

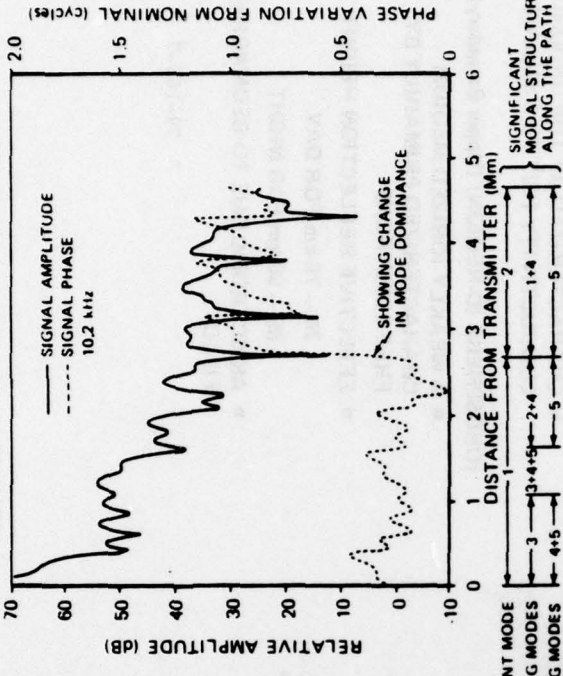

OBSERVED VLF SPATIAL MODAL INTERFERENCE FROM TRINIDAD STATION

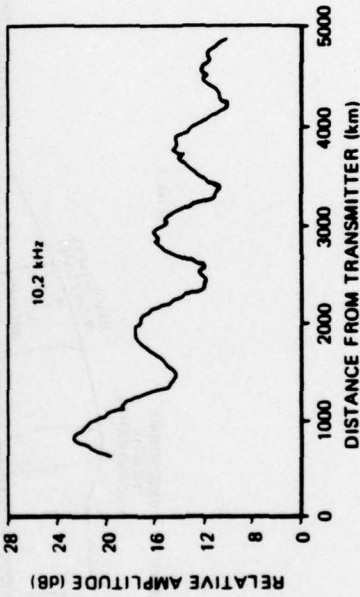

FIGURE 8. EXAMPLES OF SPATIAL MODAL INTERFERENCE ALONG INHOMOGENEOUS/NIGHT PATHS

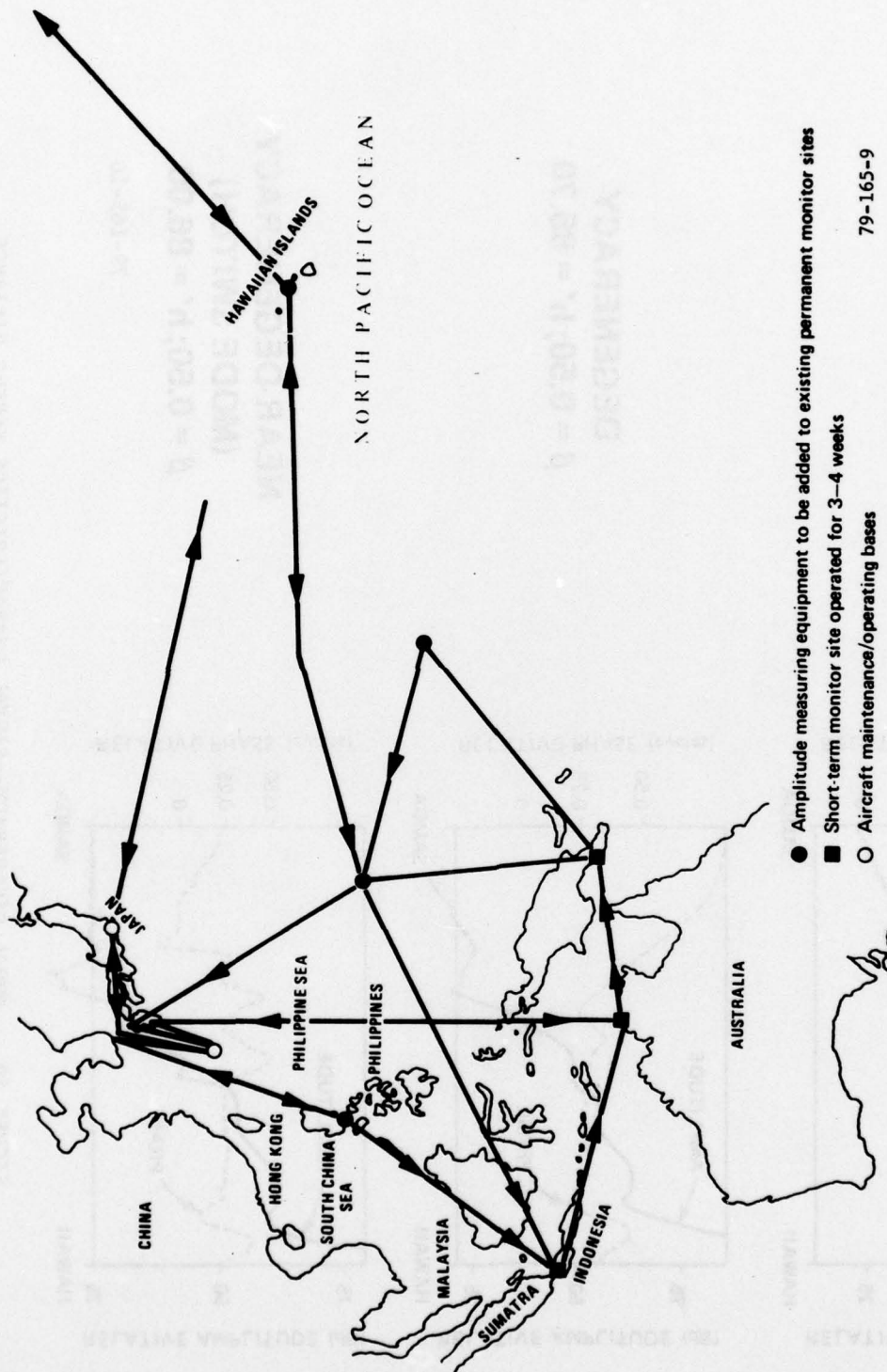
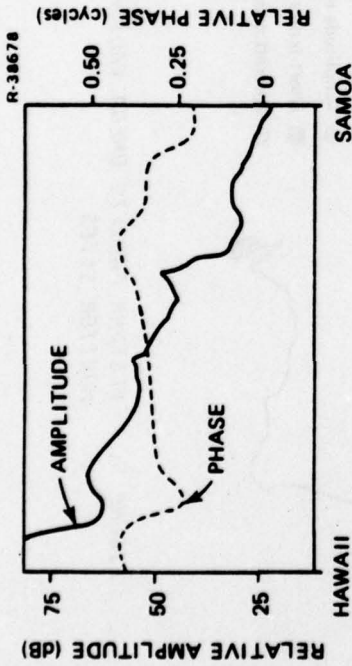
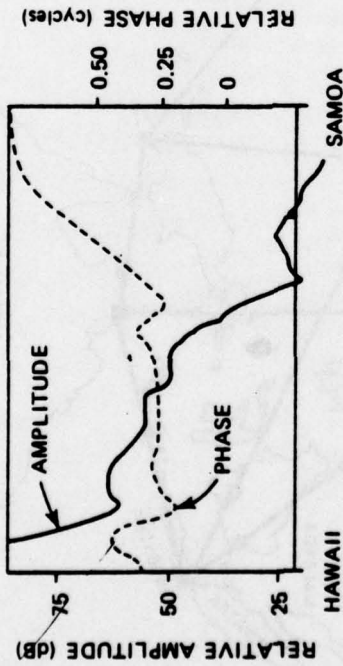

FIGURE 9. WESTERN PACIFIC OMEGA VALIDATION TEST PROGRAM FLIGHT PATHS AND FIXED MONITOR SITES



**NEAR-DEGENERACY**  
 $\beta = 0.50; h' = 85.55$



**DEGENERACY**  
 $\beta = 0.50; h' = 85.70$

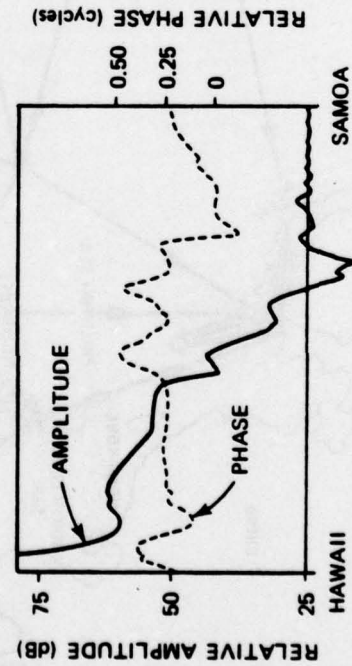

**NEAR-DEGENERACY**  
**(MODE SWITCH)**  
 $\beta = 0.50; h' = 86.00$

79-165-10

FIGURE 10. MODAL DEGENERACY--SIGNAL CHARACTERISTICS VERSUS DISTANCE (HAWAII TO SAMOA AT 10.2 kHz)

## **TERMINOLOGY**

- **"WAVEGUIDE-MODE" REPRESENTATION**

## **NORMAL SIGNAL BEHAVIOR**

- **ALMOST LINEAR PHASE VARIATION WITH DISTANCE**
- **EXPONENTIAL SIGNAL AMPLITUDE DECAY WITH DISTANCE**

## **MODAL INTERFERENCE**

- **PRESENCE OF MORE THAN ONE STRONG AMPLITUDE MODE IN THE SIGNAL**
- **QUASI-PERIODIC OSCILLATIONS IN SIGNAL WITH DISTANCE; HIGHLY UNSTABLE BEHAVIOR OVER TIME AT A FIXED POINT ON A PATH**

## **TYPES OF INTERFERENCE**

- **SPATIAL**  
**DUE TO WAVEGUIDE "BOUNDARY CONDITIONS" FAVORABLE TO HIGHER-ORDER WAVEGUIDE MODES**
- **MODE CONVERSION**  
**DUE TO ABRUPT CHANGES IN PATH-BOUNDARY CONDITIONS (e.g., DAY/NIGHT TERMINATOR OR A CONDUCTIVITY DISCONTINUITY ALONG A PATH)**

TABLE 4. MODAL INTERFERENCE PHENOMENA

REFERENCES

1. Maxwell, E. L., and Stone, D.L., 10 kc Atmospheric Noise Prediction, DECO Report No. 54-F2, 1965.
2. Budden, K. G., The Waveguide Mode Theory of Wave Propagation, Logos Press, London, 1961.
3. Pappert, R. A., Gossard, E. E., and Rothmuller, I. J., A Numerical Investigation Of Classical
4. Swanson, E. R., VLF Phase Prediction, VLF Propagation, G. Bjontegard, ed., Proc. from the VLF Symposium, Sandefjord, Norway, October 27-29, 1971, Norwegian Institute Of Cosmic Physics, Report No. 7201, January 1972.

OMEGA PERFORMANCE IN AIR  
CARRIER OPERATIONS



Patrick R. J. Reynolds  
Pan American World Airways

(This abstract was prepared by Chairman Scavullo from a transcript of tape recording. Circumstances prevented Mr. Reynolds from providing a publishable manuscript for these proceedings.)

This historical background for replacing LORAN-A in the Pan American fleet of 40 aircraft was reviewed from trials of Omega navigation sets through comparative testing of available equipments. Operational trials in the Atlantic from New York to Denmark and Germany, and in the Pacific between the United States and Tahiti, New Zealand, Australia, Hong Kong, and Japan were described.

Comparisons were made of both H-field and E-field antennas. Successful placement of H-field antennas were mentioned. Four vendors offered production models of Omega equipment for the third phase of operational comparisons over extensive oceanic routes. Usually, more than three stations were received. Findings about the effect of Greenland were mentioned and the infrequency of evidence of solar disturbance to navigation was emphasized. Modal interference was indicated as the most troublesome effect of propagation or accuracy of navigation

in the Atlantic area. Accuracy data were enumerated as based primarily on checks at known points, usually at termini of oceanic flights.

Question (Dr. Reder) Have you observed the Greenland shadow effect when Greenland was at night? In summer, Greenland is not at night.

Response (Reynolds) Yes sir, many times. I have tracked Norway both summer and winter on westbound flights to learn where Norway goes below threshold. It does so about 80 to 85 degrees west longitude if tracking across Midnorthern Canada. Signal-to-noise ratio does not start to fall off until you have cleared the west coast of Greenland with its whole width between you and the transmitter.

Remarks (Dr. Reder) When Greenland is in shade,...that is at night... then one should not expect automatically to lose the signal. The problem starts as soon as the sun rises.

Response (Reynolds) I have not tracked it to that level of detail. The Winnipeg Hole is a reasonably good handle. You just don't see past Greenland.

SOLAR FLARE FORECASTING AND  
EFFECTS ON OMEGA



Dr. Paul Levine  
Megatek Corporation

BIOGRAPHY

Dr. Levine is Chief Scientist of Megatek Corporation and holds a Ph.D. in Theoretical Physics from Cal Tech. He has worked extensively on the development of minicomputer systems for real-time radio propagation forecasting, data acquisition/analysis, and control. His publications include analyses of the relationship between navigation accuracy and traffic safety, mitigation of SID effects on radio navigation systems, and Differential Omega for the U.S. coastal confluence region.

\*\*\*\*\*

(An analogy between this talk and the fan dancer's fan: it calls attention to the subject without fully covering it.) A solar flare is an explosion on the surface of the sun, an eruption with energy equivalent to millions of megatons of TNT. When one occurs, the electromagnetic radiation which emanates immediately is followed by a stream of solar gas, largely protons, in nominally radial directions in patterns distorted by

the magnetic field and interactions with earth's magnetosphere. Ultra-violet and X-ray radiation arriving in connection with a flare has the net effect of lowering the ionosphere. As a result of the net change in waveguide dimensions, there may be expected a phase advance due to an increase in phase velocity over the path as though the station were getting closer to the receiver. The change only occurs over the daylight portion of the total path.

It has been said that effects of sudden ionospheric disturbances are rarely seen in practical navigation; this can be misleading. In a given situation, a receiver in daylight will think itself closer simultaneously to all stations whose propagation arrives over some sunlit path. These false displacements are rarely equal as their extent is governed by the length of the daylight path and the solar zenith angle along the path. But, evidently, there would be some mutual cancellation of the shifts towards multiple stations. The vector resultant would be significantly smaller than if only one signal were advanced in phase.

Thus, the net effect, or resultant error vector, depends on the time at which the flare takes effect and on the Omega propagation matrix. A history of experience which shows little degradation to navigation performance, related to sudden ionospheric disturbance, has thus to be analyzed according to the time of day and geometry of the situation. Failure to observe significant SID effects to date does not guarantee that the future will be free from important effects when circumstances are conducive to them.

Eventually, the solar-proton particles reach the earth, interact with earth's magnetic field spiral into the polar areas over a more extended time period. A delay of 8.3 minutes is involved in propagation of solar X-rays and extreme ultraviolet from sun to earth. Both can cause increased ionization of the D region of the ionosphere effectively decreasing the height of the waveguide and increasing the wave velocity. About 15 minutes to several hours later, the larger particles, (protons, and alpha particles) reach the earth and affect the waveguide down to a latitude of 60 degrees with respect to the magnetic poles; depending on actual energy levels, they increase ionization in the polar cap region for periods of several days. About 20 to 40 hours after onset, the energetic particles, interacting with the magnetosphere and the lower ionosphere, produce magnetic storms whose worst impact is to HF propagation; they do not directly affect VLF very much.

Our recent experience of the past few years cannot suffice entirely since we have been observing during a relatively quiet part of the

solar cycle. Solar physicists think of a 22-year cycle because of the changing polarity of the solar field. Effects build up to a peak every 11 years, but the polarity alternates. Going back to 1740, the recorded solar cycles were analyzed by NOSC/NELC which fitted with precise time series (figure 11) to obtain a basis for forecasting by extrapolation. This forecast of a major upcoming cycle disagreed with other forecasters including NASA, which anticipated a relatively minor cycle. Recent observations tend to confirm that we are instead moving into a very strong solar cycle with effects likely to be more pronounced than in any recent history. The 1969 maximum involved disturbances on more than 20 days per month on the average. Of course, some were of low intensity and some of short duration so that their effect on navigation was small or negligible. But, soon we can expect an increasing number of days per month when solar effects will be of more than academic interest.

Correlation of the 1-to-8 A<sup>x</sup> X-ray flux, detected by a satellite, with the phase advance of an Omega signal on the same time base shows (figure 12) the peaks occur in approximate coincidence, but phase recovery takes somewhat longer than the X-ray decay. Swanson and Kugel (reference 5), in 1974, published synoptic data on sudden phase anomaly parameters. For example (figure 13) on a path from Hawaii to Rome, New York, the maximum offset for different years was typified by a mean peak excursion of some 25 centicycles, but there is a long tail on the distribution and some events are larger indeed.

The phase rate of change during onset typically over a rise of

10 minutes is about 3 to 4 centicycles per minute and the decay takes about 40 minutes. (An effective technique for detection of SPA's is to note unusual rates of change.) The duration distribution shows that, on the average, effects last 45 to 60 minutes although some phenomena last for several hours. Recovery is much slower at perhaps 0.6 centicycle per minute.

Regularities exist in the SID's: at 13.6 kHz the phase excursions are less on a given path than at 10.2 kHz in proportion roughly to the ratio of the wavelengths. (Above about 15 kHz, phase advances would begin to increase as the frequency increases.)

The probability of observing a phase offset of some value greater than 30 centicycles varies from year to year and is perhaps a few percent. As the sunspot number reaches about 90 to 100, some 300 events per year may be expected on a global basis.

Polar Cap Absorption Effects (PCA's)  
PCA's are considerably rarer than SID's--with a typical frequency of occurrence of 20 per year at solar maximum. Position error could reach more than 13 to 15 nmi as the PCA proceeds over a period of days (figure 14). Sometimes PCA's can have a rapid onset of the order of 1 hour. In such cases, pilots need to be told when a threatening disturbance is in progress. A multihour flight can be planned to take place during a PCA once initialization has been accomplished over a known point; the event tends to remain stable over a reasonably long time. In other words, a PCA correction often can be calculated in advance.

### PROPHET

At the Naval Ocean Systems Center, the so-called PROPHET system is equipped with a VLF tracking receiver, oblique HF sounder receiver, and a radio telescope for observing the sun; it is linked both to the Air Force Global Weather Central and to the Space Environment Services Center of NOAA in Boulder, Colorado, and to other real-time resources for monitoring the solar environment. The idea is to deploy at a variety of user facilities (figure 15), specialized minicomputer-based terminals that will take a subset of the real-time data base to do operational management of radio frequency systems. A terminal is presently running which was configured for HF frequency management; it could be geared as well to VLF services. As a step in this direction, on an experimental basis, the terminal contains algorithms which attempt to predict, in real-time, what the additional PPC's due to the current output of the sun should be. Using one of ONSOD's monitor receivers, an experimental program is underway at NOSC to generate minute-by-minute predictions of phase advances on all the paths while observing the flares, comparing predictions with the receiver output, and through several iterations to secure a refined disturbance model.

It is also possible to undo the effect of a PCA by means of real-time monitoring. Satellites are now making proton measurements which could be combined with PCA correction models already available at NOSC to determine the corrections to lines of position. In this way, typical PCA-induced navigation inaccuracies

of 7 to 8 nmi can be reduced to the nominal accuracy level of the Omega or VLF system.

#### Omega/VLF Navigation Signal Monitor

Omega signals can be monitored at a fixed location by a receiver linked to a minicomputer (figure 16), which loads a floppy disk to maintain an archive of nominal diurnal phase variations derived from averaging the output of the receiver over many days. The computer can judge instantaneously any deviations from the norm. By consistency checks, the computer identifies causes of any anomaly, evaluates the Omega system status, conveys to its operator (here the FAA): (1) the occurrence of an anomaly or fault in the system, (2) its probable cause, and (3) recommended actions. Since May 1978, the system has operated at NAFEC with Omega signals only. The terminal will be expanded soon to include VLF signals being applied to navigation.

#### Automatic SID Cancellation

The next generation of airborne Omega/VLF navigation equipment might have embodied in its software another potential approach to countering the effects of solar activity. The regularities of SID effects, the fact that they scale with frequency and with daytime path length in certain known ways, means that the Omega and VLF signals can be combined taking these effects into account when determining a fix. A paper (reference 6) published in the 1976 Marine Navigation Symposium in San Diego, California showed that the signals could be combined, with the help of an auxiliary

position input, such as dead reckoning, so as to subtract out to a large degree the effects of SID's. The corrected residuals are plotted as a function of the uncorrected residuals during SID's in figure 17. Even though an error as large as 40 centicycles has been induced by an SID, the correction algorithm can reduce the net inaccuracy to about 4 centicycles.

#### CONCLUSION

In conclusion, we may expect in the near future that solar effects will be more frequently noted and scrutinized in more detail than have been possible before. The data base that will be collected in the new Omega data bank should be extremely valuable for the analysis of these events since there will likely be several recorders flying at the time of an event in different parts of the globe. Modeling the effects of SID's on Omega can then be made more realistic with such well-dispersed, phase-tracking measurements during the flare, together with instantaneous X-ray data taken by solar observing satellites. Above all, it may be premature to say that (based on subjective impressions of the past) solar effects need not cause concern in navigation; there will be times and places where the stations in use for navigation will not yield a vectorial cancellation of SID-induced errors. Errors of the order of 8 to 10 nmi miles due to SID's will occur. Techniques are currently under development for warning the airborne navigator when such errors are expected and for mitigating SID-induced errors by more sophisticated navigation software.

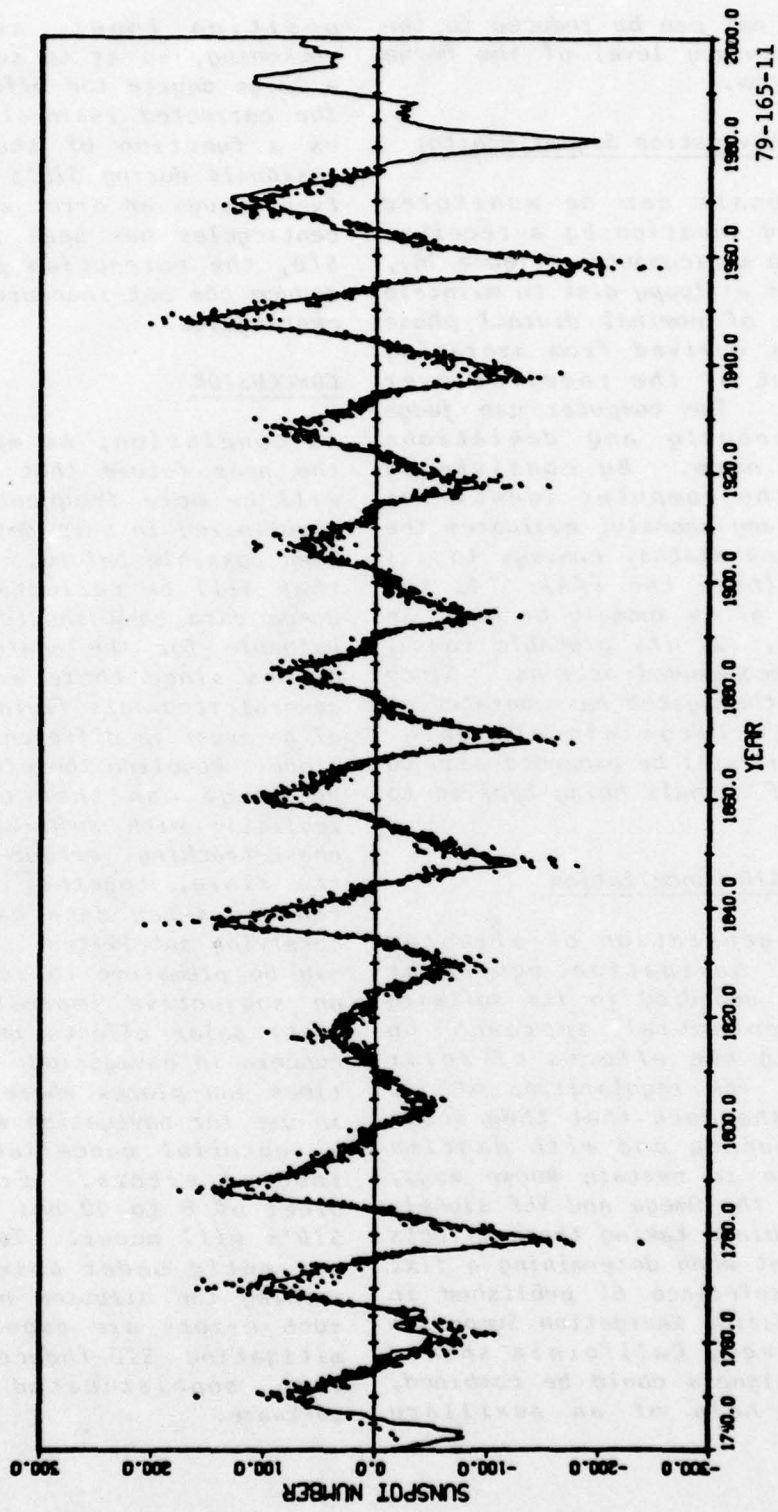

FIGURE 11. OBSERVED AND PREDICTED MONTHLY SUNSPOT NUMBERS

(11 JULY - 12 JULY 1968)

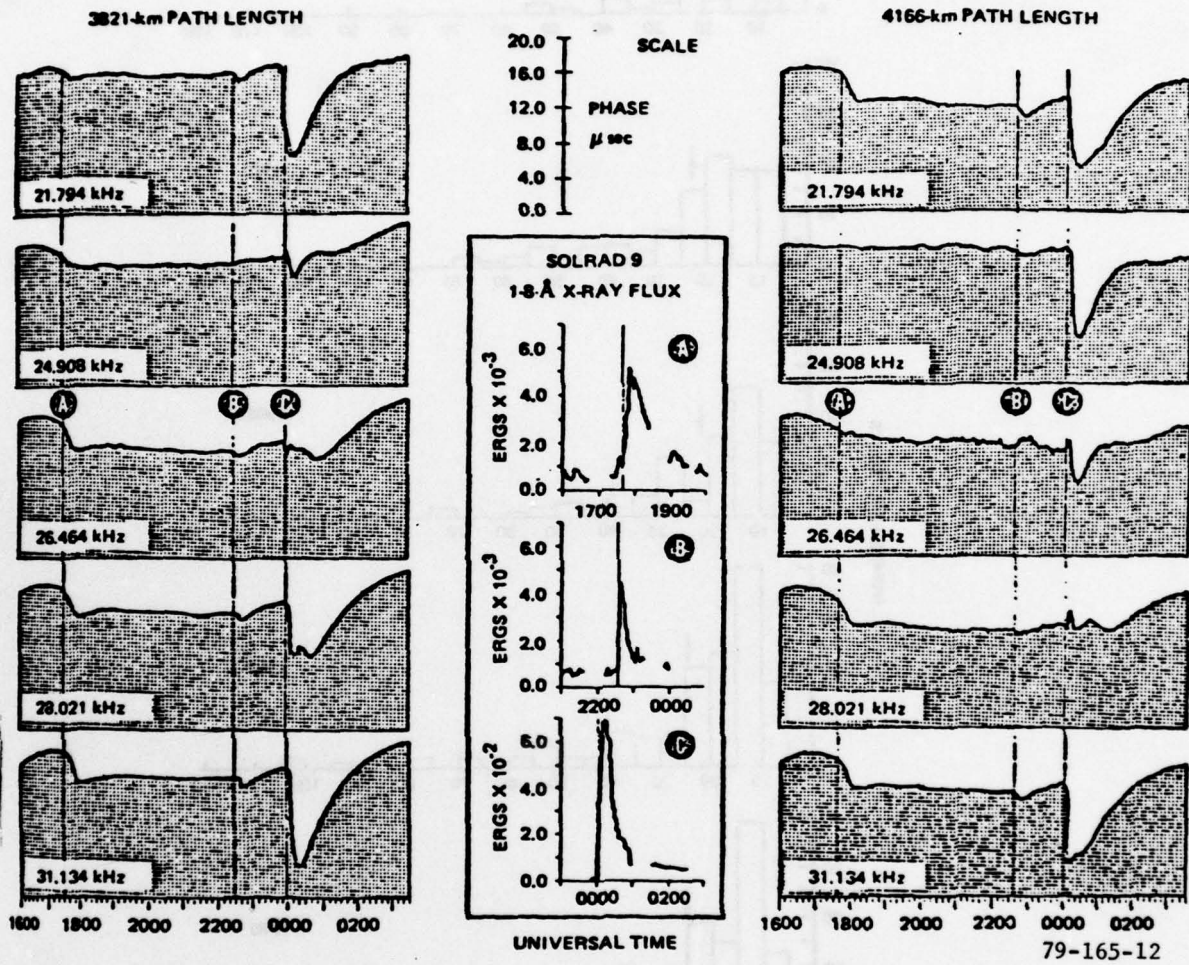
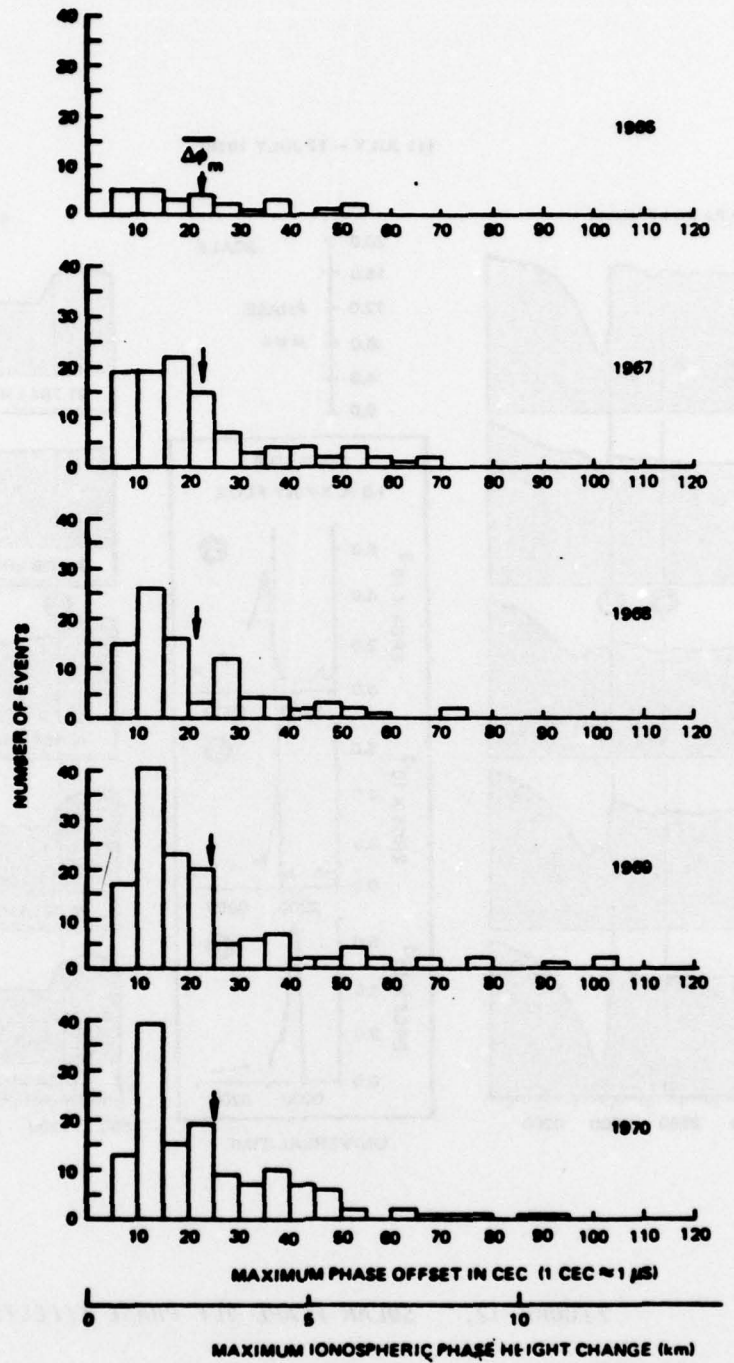

FIGURE 12. SOLAR FLARE VLF PHASE EFFECTS



79-165-13

FIGURE 13. MAXIMUM PHASE-OFFSET DISTRIBUTIONS OBSERVED DURING SPA EVENTS ON HAWAII TO NEW YORK PATH AT 10.2 KHz

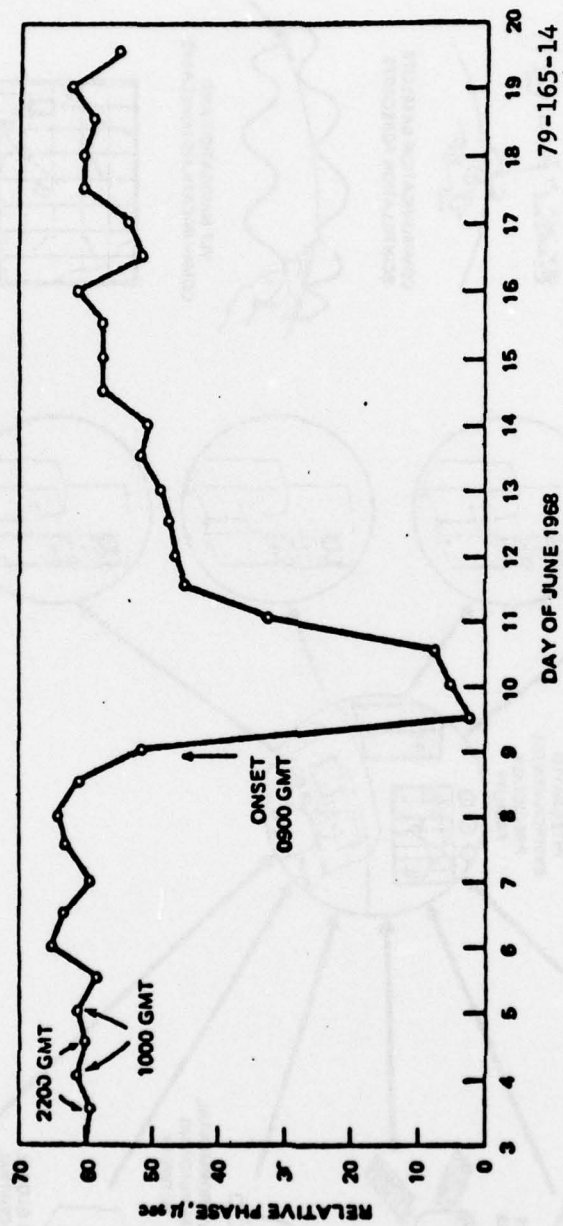

FIGURE 14. PCA EFFECTS OF OMEGA PHASE, NORWAY TO HAWAII

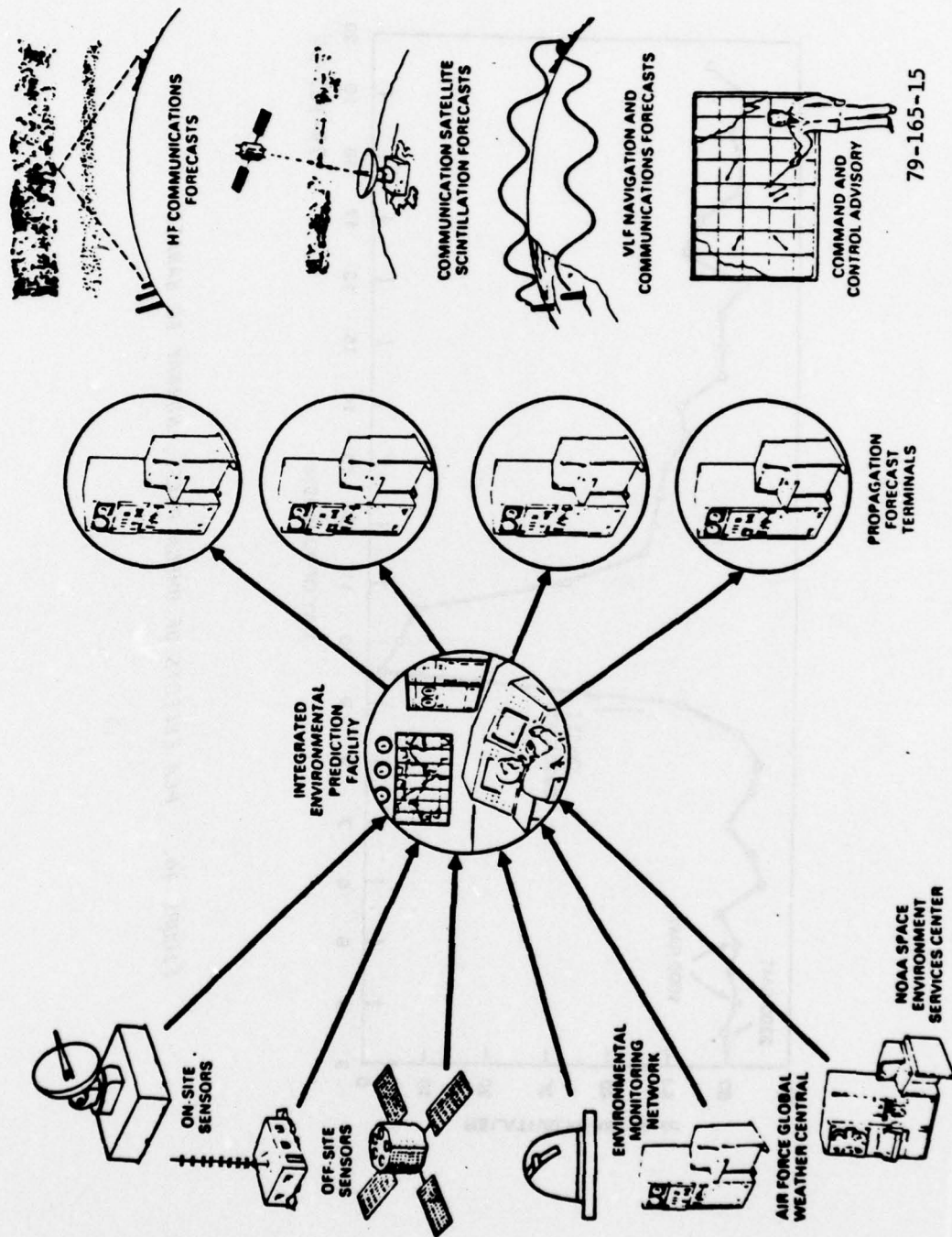

FIGURE 15. PROPHET: SYSTEM CONCEPT



FIGURE 16. PROTOTYPE SYSTEM HARDWARE

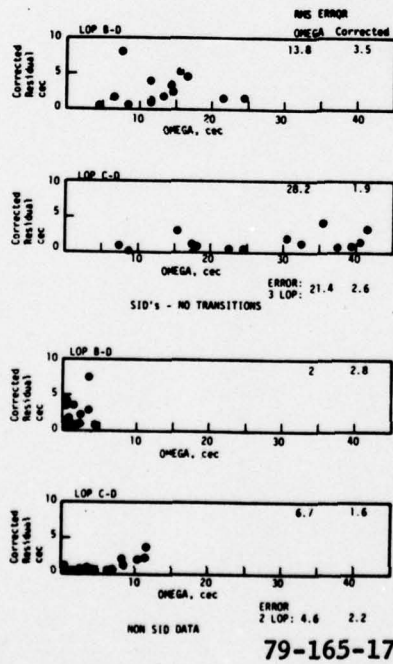

FIGURE 17. SID CORRECTIONS: NO DIURNAL TRANSITIONS

REFERENCES

5. Swanson, E. R., Kugel, C. P.,  
A Synoptic Study of Sudden Phase  
Anomalies (SPA's) Effecting VLF  
Navigation and Timing, Proceedings  
of the Fifth Annual NASA/DOD Precise  
Time and Time Interval Planning  
Meeting, NASA Pub. No. X-814-74-225,  
pgs. 443-471, December 4-6, 1973.

6. Andrian, D. J., Levine, P. H.,  
An Algorithm For Reducing the Effects  
of SID's on OMEGA in Integrated  
Navigation Systems, Technical Paper  
given at the Marine Navigation  
Symposium, San Diego, California,  
1976.

A BANK FOR OMEGA  
PROPAGATION DATA



*Dr. Lorraine Rzonca  
Federal Aviation Administration*

BIOGRAPHY

*Dr. Lorraine Rzonca is a physicist in the LORAN-C/VLF/Omega program at NAFEC collecting and analyzing LORAN-C and Omega data in mountainous areas and contributing to the development of the Bank For Airborne Omega Propagation Data. Dr. Rzonca holds a B.S. degree from Drexel University, M.S. and Ph.D. degrees from the University of Massachusetts. Her Ph.D. dissertation, which builds upon the kinetic theory of rarefied gases to develop a model of shock waves in quantum gases, serves as a basis for pursuing the study of ion production and interaction within the ionosphere which may affect Omega Propagation.*

\*\*\*\*\*

*The Omega data bank is for the benefit of all those who will participate. A handout (appendix A) synthesizes the present concept for handling the data now expected. We have the capability of processing large amounts of data by automation with the Honeywell 66/60 computing facility at NAFEC. Mr. Shiu Cheung,*

*a most capable programmer, has begun to work on processing architecture. Your response to this handout with its quiz at the end will be considered in designing the approach to our data-processing, analysis, and reporting.*

*Development of the data bank at NAFEC is outlined in table 5. It begins with the Omega installation in commercial aircraft, cassettes loaded with data will be returned to NAFEC, data will be transferred in our laboratory to 9-track tape for processing in the Honeywell 66/60 computing facility where the accumulated data can be examined for trends, anomalies, and performance interruptions. Finally, the data will be analyzed to assess the effects of phenomena in the propagation environment. We expect a variety of Omega navigators connected through our recorder to the data bank. After a few months of data taking, we can begin some statistical analysis. The quarterly report, to be written around this analysis, will be distributed promptly to all those who participate in the program.*

We also hope to incorporate in our bank some of the air traffic control gateway fixes and some of the data received by the ONSOD monitor network will be studied for correlation. Solar and geophysical data supplied by NOAA will be studied and their implications covered in a final report.

The types of information expected from the airborne Omega recorders are tabulated in an enclosure to the handout, (see pgs. A-1 through A-3). Some avionics can deliver more items and some less. But, each aircraft-Omega combination will be treated as a unit type. The aircraft will traverse cells 10° longitude by 10° latitude. One early treatment will be to distribute experience of the several aircraft-Omega units over the geographic cells. Unit characteristics and geographic cell characteristics will be derived in statistical terms. Another treatment will be to combine unit and all characteristics into overall Omega statistics (figure 18).

The statistical reports will include anomalous propagation events, discontinuities in signal reception, unexpected signal phase shifts, loss of proper lane count, levels of signal-to-noise experienced, time correlation of airborne data with ONSOD ground monitor, and NOAA data. Of course, complete printouts of the cassette records will be sent to participants who supply them for whatever use they may have for the printouts.

Benefits are seen to include developments of the statistical characteristics of signal coverage and its variations, separations of anomalies into problems due to the avionics,

installation, propagation, or transmitter performance. Air carriers will have confirmation of the long-term operational reliability of the Omega navigation system to support their decisions regarding purchase, installation, continued use, or extension of Omega to other aircraft. Some of the data could support development of guidelines for pilot training.

The FAA hopes to obtain reliable data for the certification of Omega and will apply it to simulations of proposed, unproven, air routes. Manufacturers would use the data to support claims for the equipment and learn from the data bank records whether there is any need to change either hardware or software.

NAFEC's experience has involved probe flights (figure 19), but systematic repetitive coverage of wide ocean areas has not been undertaken. During January 1976, NAFEC personnel took a portable recorder onboard a TWA aircraft which had been equipped with the early Litton-Amecom ONS-201 Omega set. During one night flight from New York to London, dead reckoning occurred. The recorded data were examined later for all five crossings, two of which were in daylight going westward, and the others were at night going to the east. The records showed a dramatic dip in signal-to-noise ratio (SNR) on 10.2 kHz from all the stations in operation at that time. The dip occurred during some 30 minutes between 30° and 20° west longitude and latitude 55° north. The record from the crossing 2 weeks sooner also showed a similar, but less severe, dip at about the same place, i.e., between 30° and 20° west, but at 52° north.

We were invited back again in July 1976 once an early production model of the Dynell ONS Mark VII had been substituted by TWA in the same aircraft. We could not obtain SNR, but the number of stations judged useable reduced noticeably in the same geographic area marked earlier by dips in SNR. Was all this coincidental? Evidently, more information is available from the ONS-201 than from the Mark VII.

What do the dips mean? Are they related to geography, are they localized, isolated, peculiar to a particular aircraft? Data based on several carriers flying the same routes at different times and seasons with different equipment are needed both for discovery and for reassurance.

It has been noticed already that hand copied (kneepad) data are collected in-flight at relatively low rates. Reliable kneepad records usually are not written more frequently than every 15 minutes, and many are written only on arrival at waypoints designated in the flight plan. Clearly, imperfections in signal quality can be overlooked if they do not overlap the actual hand copy process. We would try to sample all data every minute during a flight so we did not advance more than one full Omega lane before the next sample.

To summarize the results of the early probes, it may be said that the avionics generally functioned admirably and reliably, the available Omega signals from the transmitters have improved with time, dips in SNR were not always correlated with periods of dead reckoning, received signal-to-noise seemed to dip from all stations at the same time and

in specific areas, and we may say that Omega propagation may be affected by natural phenomena both randomly and systematically.

At present, we are flying probe flights with a Bendix early model ONS-20 interfaced with a specially tailored digital recorder. We have flown in Alaska and in the Carribean. En route to Alaska, in a Convair CV-580 aircraft, we traversed Canada, passing through the Winnipeg Hole. Nothing dramatic was noticed.

Signals from stations Hawaii and North Dakota suffered a 5-minute drop of signal-to-noise ratio from a level of 10 to a level of 3. Evidently, the boundaries of the so-called Winnipeg Hole have some mobility. Later, we passed over Edmonton and the Yukon en route to Anchorage. We noticed temporary reduction of signal-to-noise ratio for periods from 5 to 7 minutes from levels near 10 to levels of 6-7. On one occasion, SNR dropped below the threshold for about 5 minutes and the ONS-20 dead reckoned through the interval. The effect of Greenland and other predictable phenomena were all observed with some satisfaction.

One flight from Anchorage included a 5-minute dip in SNR which denied us Norway, Hawaii, and Japan. Approaching Gulkana, Alaska, we were at minimum en route altitude. As a result, sometimes we were behind certain peaks. It was tempting to associate loss of signal-to-noise to those peaks. In one case, North Dakota dipped below threshold for about 30 minutes. Ten minutes later, at an altitude of 8,000 feet, Norway also suffered a 30-minute dip. It was our opinion that the 17,000-foot mountains obstructed the Norway signal. En route from

Fairbanks to Chandelar Lake at an altitude of 12,000 feet, Mount McKinley seemed to loom between us and station Hawaii which caused the Hawaii signal to dip dramatically.

Question (Scull) Was there much snow on the mountains?

Response (Dr. Rzonca) Yes, it seemed quite a lot to me for summer time. Analysis of the data from Alaska has not yet been completed.

Data from the flights in the Convair CV-880 aircraft, taken over the Carribean during the first sequence of the 1978 North Atlantic Omega validation mission, have not been transcribed from cassettes to computer tape. However, as I observed it, the position readout on the ONS-20 display seemed to lag the INS position by 1/2 to 1 minute of arc. There seemed to be a north-bias relative to the Litton Model LTN-51 INS.

When we flew a radius-of-action mission out from San Juan along the 288° radial out of Liberia, once again, ONS-20 was north of LTN-51. Each leg of the two-way flight must be examined separately. Great care, as expected, needs to be applied in order to make statistical sense.

During the northerly radius-of-action flights out of Bermuda, the north bias was offset along track by the usual lag, whereas, on the return to Bermuda, the lag and north bias added together.

Question (Carmel) Is the INS always correct? Is the error always in the ONS?

Response (Dr. Rzonca) Not always; sometimes ramp position is incorrect by a few tenths up to about 2 minutes in the worst case. Yes, the INS is taken as the reference so ONS error is really the ONS minus the INS values.

On another flight out of Bermuda, navigating on the Liberia 305° radial, the northerly offset in ONS position was apparent, but on the return leg of the same radial the north offset did not show up.

A sample printout from ONS-20 is illustrated in table 6. Greenwich Mean Time (GMT), present position, station status, SNR for all received frequencies, and aircraft information are compacted in a small page area.

The graphic format used for plotting SNR data is illustrated in figure 29. It represents the 10.2 kHz SNR variations in the signal from Liberia recorded at 1-minute intervals during a flight on July 19, 1978 from San Juan, Puerto Rico to Merida, Mexico.

Question (Dr. Reder) Did the operator notice the dip as it happened or was it only found out after the flight?

Response (Dr. Rzonca) This behavior was observed in the aircraft and plotted later. There was a Tracor 599 receiver onboard along with a strip-chart pen recorder, but it was not monitored continuously during the flight.

Observation (Dr. Reder) If you could observe such a dip in flight, then you could fly back and forth over the same course and determine if there was any relation to position.

The signal from North Dakota was usually observed to be very strong during the flights, but the record later showed several instances of dramatic loss of SNR. Similar plots for the same flights are to be made for 13.5 kHz and 11 1/3 kHz. The few plots we have for 13.5 kHz show similar dips which were recorded at the same times as the 10.2 kHz signals. As we flew closer to a station, received signals became stronger; as we flew away along radials, we could also see the SNR decrease.

Please complete the homework handed out to you (see appendix A, pgs. A-3 through A-8). It will help us anticipate your needs. While we won't be able to report anything until the bank is supplied with data, our planning for software and processing has to be undertaken without delay. What is important to your operations? Individual flight reports with your designated listings can be compiled and distributed rather quickly. I will look at lateral deviations greater than 3 and 6.3 nmi, dips in SNR, time of occurrence, seasons, and geographic locations. In the quarterly reports, we start combining data from all units in all cells.

One statistical treatment will be the sequential sampling of lateral deviation. Excess deviations will be correlated with:

1. Effect of PCA's on accuracy--will check with changes observed at ground monitors.
2. Changes in SNR are to be correlated with increase atmospheric radio noise.
3. Occurrence of transmitter outages and power reductions of course will be matched to our data.

Omega data will be collected in-flight over a 2-year period. At the end, a final report will encompass all the information in the bank. Emphasis will be given to distributions of inaccuracies as they may affect criteria for track dimensions.

We will try to evaluate the PROPHEX/Omega real-time monitor giving attention to solar geophysical phenomena occurring during the period.

It's going to be your bank. You can expect to get out of it what you put into it (with interest). A truly cooperative effort should prove most valuable. Perhaps some of you would like to raise some questions at this time?

Question (Dr. Levine) How fine grained will the accuracy measurements be? Will you take objective fixes only at continental gateways?

Response (Dr. Rzonca) As I now envision it (for most Omega equipped aircraft), it will just be at the gateway. But, we might be able to arrange more readings depending on geographical area and what participants can handle in their aircraft.

Comment (Dr. Levine) Mr. Robert Morrison and others have a pretty good handle on methods of getting more accuracy data.

Response (Scavullo) Tomorrow you will see that the digital recorder can handle concurrently the Omega output and output from one or more other digital systems. Carriers offering more accurate position data from another source in the aircraft can record it for ready comparison with the Omega. However, for purposes of sorting our observations

into 10° by 10° cells, we will be satisfied with the position as determined within the Omega set.

Question (Dr. Reder) Did all the signal-to-noise ratios for all stations dip together during the January 1976 flights?

Response (Dr. Rzonca) Yes, each of the several signals showed a dip at the same time.

Question (Dr. Reder) Did you check into the possibility of nearby thunderstorms?

Response (Dr. Rzonca) No, I did not check that.

Comment (Moore) At the time these flights were conducted, weather conditions were clear along the lanes being traveled. All flights were at jet altitudes in North Atlantic latitudes on the approaches to Shannon, Ireland. I have only observed all stations providing poor reception simultaneously on these two flights, except when traversing Greenland.

Comment (Scavullo) Repeating oceanic trips for verification could not be done in government aircraft alone. Three round trips in the CV-880 from Gander to Shannon and back via Keflavik in 1975 were priced at \$50,000. We have placed ONS-20 and recorders in three FAA aircraft and we have ordered a Canadian Marconi CMA-740 with data output provisions. Some tapes are already coming back. If unusual phenomena are found to recur locally during the commercial flights, we will probe the area more carefully with an instrumented government airplane for an explanation.

Question (Unidentified) How much of an accuracy factor are you putting in your (ATC) radar call?

Response (Scavullo) Flight standards has worked out a technique in connection with the MNPS program. I am not able to place a value on the accuracy of the radar call since I have never worked with it.

Comment (Unidentified) ...checking inbound and outbound. We know right now that we have errors up to 5 miles.

Response (Scavullo) We never know exactly what the errors are. We are more comfortable talking about the differences between Omega and the reference, usually INS; we don't always know if INS is exactly correct.

Question (Davis) Accuracy will always be a problem. Accuracy relative to what? Even if you have an INS in the aircraft, you have to calibrate the reference.

Response (Scavullo) We are not primarily concerned with accuracy here. Those airlines (operators) with high confidence in the accuracy and precision of their (other) onboard systems may agree to have position derived from an INS or Doppler navigator recorded on the cassettes along with ONS position. We will give them printouts showing how the two systems compared. Perhaps the Omega manufacturers will convince us that their equipment has been perfected so it produces no noticeable contribution to navigation inaccuracy. We expect ONSOD to perfect all ground stations finally so they transmit with utter consistency and complete reliability

in all useful directions. But, we are not sure about the propagation environment. This majestic natural subsystem must be studied by FAA in fulfilling its responsibilities about Omega navigation. What can be done about its unpredictable propagation disturbances? We do not know how to stop a SID or a PCA. We can learn more about them so that rational judgment can be made whether anything can be done to the transmitting or viewing subsystem and what that should be. Perhaps nothing should be attempted. Where do we get the most anomalies; when do they occur; what mechanisms bring them about; which of these can be compensated? For example, the evidence described by Dr. Rzonca of a "hole" between 30° and 20° west en route to England from New York may never be repeated. But, if it is seen several more times, we would focus our analysis on possible explanations until we were sure whether the cause was some geophysical mechanism such as local gravity vectors or errant electrojets in the ionosphere. That is why we have assigned a physicist to this project.

Question (Dr. Reder) Is there any possibility that the suspected hole west of Shannon was actually an equipment problem? What could have happened in the airplane on all those crossings?

Response (Dr. Rzonca) It is possible. But the dips were seen on different occasions in the same locale with two different Omega sets. All three crossings were in the same aircraft. We will continue to seek an explanation, but none has been presented to us yet. We are trying to collect a lot of different status words now other than Omega

data, but we don't yet know whether we are leaving out something helpful.

Question (Carmel) What is the likelihood that harmonics of 400 kHz could have increased along power circuits in the aircraft?

Response (Scavullo) It is possible that noise surges along power lines in the aircraft could enter the system to affect SNR. We were not instrumented to check for power-frequency harmonics in the TWA aircraft. In the NAFEC aircraft, our project power is regulated separately and furnished by a separate power supply. It had not occurred to me as yet to monitor line frequency or its harmonics.

Comment (Erikson) If we have enough recorders installed in different aircraft/avionics units, we can expect to sort out between equipment difficulties and propagation anomalies when an effect is repeated.

Response (Dr. Reder) We have to test the reaction of receivers to sudden changes of input and, as Mr. Carmel pointed out, to change in line frequency. We have observed harmonics of 400 kHz power interfering with Omega signals. The other possibility is that we pick up external signals and get interference on a harmonic of signals from other sources such as VLF communications system frequencies with a very strong response though it is not on Omega frequency. We have observed this interference from Forestport, about 20 dB, which is only separated from Fort Monmouth by 200 miles. And our airplane was flying in the Caribbean area.

Comment (Scavullo) It is a comfort to realize that Dr. Reder's office

is only 100 miles from NAFEC. When we can visit him, we will go through his check-off list to be sure we don't overlook something important in our next test program.

Question (Carmel) Mr. Quinn, it bothers me that the "World" as used to label the "World-Wide Omega Navigation System" does not really include the sponsoring nation, the United States. Your presentation specifically referred to the oceanic routes, but not to overland flight. You seem to be concentrating on the commercial oceanic airline data. In CONUS, there is a problem for users of Omega and overland performance should be included in the data bank. There are other sources of Omega information than the airlines. I am a representative of the nonair-carrier segment of the flying community and there are several others also here at this meeting who might supply Omega data.

Response (Quinn) I see no reason why we cannot include data taken over the continental U.S. We are especially interested in the system operation in Alaska. Transport of Canada and the FAA are joined in a project to evaluate differential Omega in Alaska. The work should begin shortly. There are predictions from Peter Morris and friends that the reception of Omega over the central U.S. after midsummer noon

is not to be relied upon. We are interested in the data and in participation by the members of NBAA or any other business aircraft.

Comment (Unidentified) One of the FAA 727's will be flying the SAFI patterns regularly with ONS-20. Some 90 percent of its flights will be domestic (CONUS).

Comment (Scavullo) The ONS-20 antenna had been installed first in the high tail of a B-727 at the FAA Aeronautical Center. The loop antenna was placed under the fiberglass at the forward part of the cap on the vertical stabilizer. That was too close to servomotors actuating the horizontal stabilizer. However, a successful installation has been made. The H-field loop has been relocated outside the cap on top at the aft part of the tail. All eight stations were received on the ground at Oklahoma City during the morning hours. Not all stations were received after noon. The aircraft is now operating out of Honolulu in its flight inspection work. Alan Carmel has been collecting data over the U.S. for several years. We are interested in looking at it in detail. But priorities have been set that require our limited energies to be expended on establishing the data bank and expediting the issuance of post-flight reports.

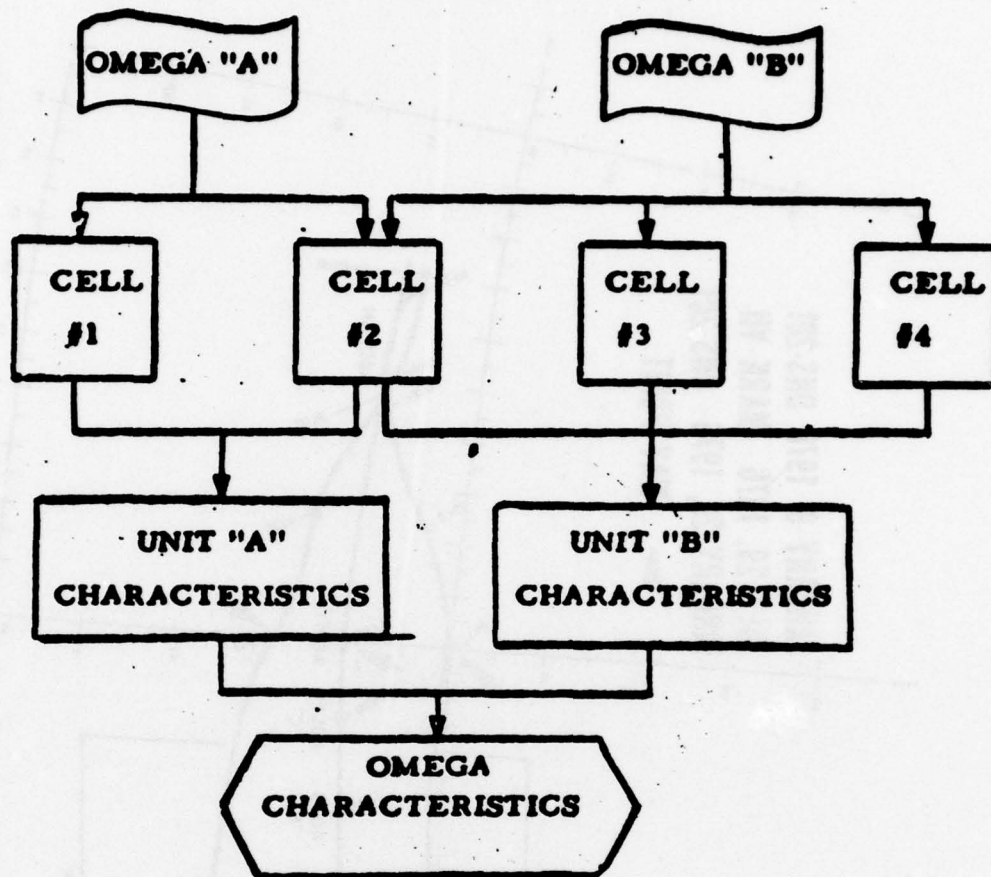

**GEOGRAPHIC CELL  
CHARACTERISTICS  
(10°LAT x 10° LONG)**

79-165-18

FIGURE 18. SCHEMATIC DIAGRAM FOR SORTING OMEGA GEOGRAPHICALLY IN THE DATA BANK



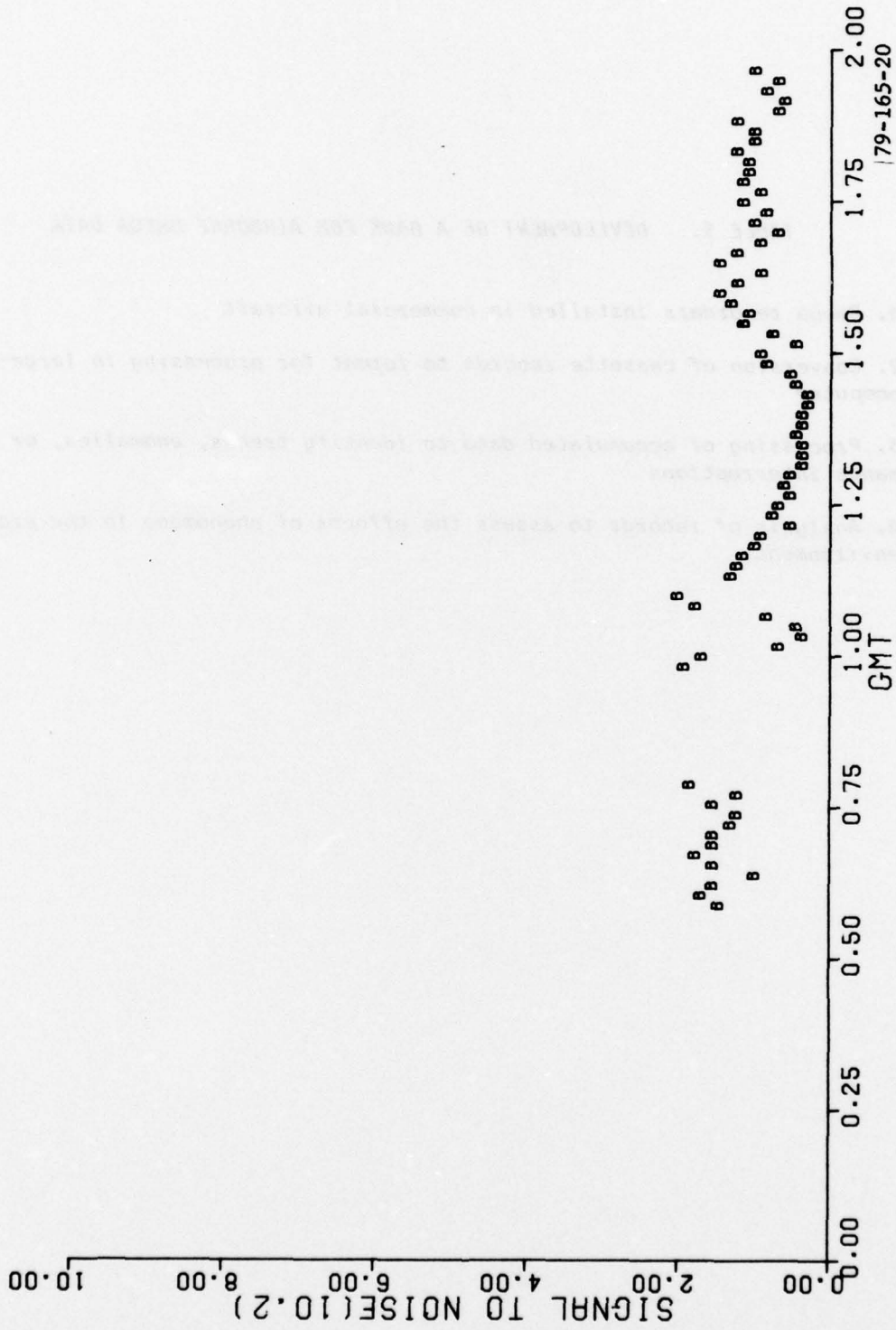

FIGURE 20. SIGNAL-TO-NOISE FLUCTUATIONS

**TABLE 5. DEVELOPMENT OF A BANK FOR AIRBORNE OMEGA DATA**

- 1. Omega recorders installed in commercial aircraft**
- 2. Conversion of cassette records to format for processing in large-scale computer**
- 3. Processing of accumulated data to identify trends, anomalies, or performance interruptions**
- 4. Analysis of records to assess the effects of phenomena in the propagation environment**

FROM LAT FROM LONG TO LAT TO LONG CHNG LAT CHNG LONG  
 D M D M D M D M D M D M D M  
 44 37.9 -65 11.2 44 37.9 -67 17.1 44 30.3 -65 9.6

GMT	PRES	LAT	PRES	LONG	STATION	STATUS	FREQ	SIGNAL	TO	NOISE	NUMBER	PR	TRACK	DSR	TK	MAG	HD	ASP	GSP	KTS	DEG	MSP	WDIR	MP	DST	X-TRK
2 57.0	44 36.3	-65 12.9	868692	38	REL	USE	10.2	13.6	11.3	5--2--2-	U+2--4-	/--5+--	BF	328.49	270.72	323.66	473	416	69	272.2	89.0	1.3				
2 58.0	44 38.2	-65 21.8	868692	38	REL	USE	F--2--B-	Z--2--0-	1--B--/-	BF	286.92	270.61	286.45	474	405	69	262.7	82.4	0.4							
2 59.0	44 38.6	-65 32.0	828692	38	REL	USE	P--2--S-	Z--2--3Z-	2--C--/-	BF	291.43	270.49	288.84	478	418	63	250.6	75.0	0.4							
3 0.0	44 38.6	-65 42.6	828692	38	REL	USE	T--2--L-	Z--2--3Z-	7--G--/-	BF	292.46	270.37	289.67	479	427	56	247.0	67.6	0.5							
3 1.0	44 38.2	-65 52.8	828692	38	REL	USE	Z--2--S-	Z--2--2Z-	5--B--/-	BF	290.62	270.25	289.40	479	431	49	257.7	60.3	0.4							
3 2.0	44 37.6	-66 3.0	828692	38	REL	USE	Q--2--M-	Z--2--3Z-	7--G--/-	BF	290.22	270.13	289.83	478	430	48	265.8	52.9	0.3							
3 3.0	44 37.6	-66 13.2	828692	38	REL	USE	Z--2--N-	Z--2--3Z-	6--4--/-	BF	289.72	270.01	289.38	481	436	46	265.6	45.5	0.5							
3 4.0	44 37.3	-66 23.8	828692	38	REL	USE	M--2--L-	Z--2--2Z-	6--9--/-	BF	289.97	269.89	289.70	478	435	43	266.5	38.3	0.6							
3 5.0	44 36.9	-66 34.0	828692	38	REL	USE	K--2--I-	Z--2--2Z-	3--5--/-	BF	288.99	269.77	289.12	478	437	41	270.0	30.9	0.9							
3 6.0	44 37.6	-66 44.2	828692	38	REL	USE	R--2--I-	Z--2--1Z-	2--8--/-	BF	289.95	269.65	288.38	479	437	43	232.3	23.5	0.1							
3 7.0	44 37.9	-66 54.7	828692	38	REL	USE	J--2--F-	Z--2--1Z-	1--6--/-	BF	290.91	269.53	288.96	478	442	39	246.3	15.9	0.4							
3 8.0	44 37.9	-67 5.0	868692	38	REL	USE	S--2--J-	Z--2--1Z-	2--6--/-	BF	290.36	269.41	288.65	478	443	38	248.2	8.5	0.4							
3 9.0	44 36.9	-67 15.5	868692	38	REL	USE	I--2--N+	Z--2--2Z-	2--6+/-	BF	281.71	249.08	282.08	478	445	33	267.0	231.0	1.3							
3 10.0	44 34.6	-67 25.4	868692	38	REL	USE	5--2--S-	M--2--2Z-	2--A--/-	BF	267.89	248.97	269.20	482	449	34	267.1	224.0	0.8							
3 11.0	44 31.7	-67 34.3	868692	38	REL	USE	2--2--Z-	A--2--1Z-	2--2--/-	BF	266.64	248.86	268.69	486	447	42	271.2	217.0	1.1							
3 12.0	44 29.3	-67 45.2	868692	38	REL	USE	4--2--U-	C--2--2Z-	2--7--/-	BF	268.68	248.74	269.40	483	452	31	260.3	209.0	0.6							
3 13.0	44 26.7	-67 55.4	868692	38	REL	USE	3--2--X-	6--1--3Z-	2--A--/-	BF	269.18	248.62	269.40	478	451	28	253.3	201.0	0.3							
3 14.0	44 24.1	-68 5.3	868692	38	REL	USE	/--2--S-	6--1--1Z-	2--7--/-	BF	268.98	248.51	269.36	480	453	27	256.9	194.5	0.1							
3 15.0	44 20.8	-68 14.8	868692	38	REL	USE	--V--Y-	3--2--5Z-	2--6+/-	BF	267.59	248.40	269.24	479	451	31	274.9	186.9	0.6							
3 16.0	44 17.8	-68 24.1	868600	30	REL	USE	--2--Y-	3--1--4Z-	2--8--/-	BF	266.62	248.28	269.32	480	450	37	285.0	179.5	1.3							
3 17.0	44 14.8	-68 33.9	868600	30	REL	USE	/--X--Q-	6--2--3Z-	2--6--/-	BF	266.55	248.16	269.36	482	454	36	288.4	171.6	1.3							
3 18.0	44 12.2	-68 44.2	868600	30	REL	USE	--Z--P-	6--2--1Z-	2--D+/-	BF	266.96	248.05	269.12	483	458	31	284.8	163.9	1.1							
3 19.0	44 9.9	-68 54.0	868600	30	REL	USE	--Z--P-	7--1--1Z-	2--8--/-	BF	268.48	247.94	269.36	482	453	29	264.8	156.6	0.4							
3 20.0	44 7.6	-69 3.9	868600	30	REL	USE	/--V--Z-	B--2--4Z-	2--L--/-	BF	264.63	247.83	264.95	480	454	26	252.2	148.9	0.4							
3 21.0	44 3.6	-69 13.2	868600	30	REL	USE	/--M--Z-	B--1--3Z+	2--5--/-	BF	262.14	247.71	263.71	484	461	26	273.8	141.3	1.0							
3 22.0	44 1.0	-69 22.7	868600	30	REL	USE	/--L--U-	6--1--1Z-	2--B--/-	BF	267.02	247.61	267.50	477	447	31	256.8	134.0	0.6							
3 23.0	43 58.7	-69 32.3	868600	30	REL	USE	--Q--R+	2--3--1Z-	2--A--/-	BF	267.50	247.50	267.85	477	446	31	255.2	128.6	0.4							
3 24.0	43 55.7	-69 42.2	868600	30	REL	USE	--S--T-	5--2--2Z-	2--H--/-	BF	267.31	247.38	268.13	483	455	29	263.1	118.9	0.3							
3 25.0	43 52.8	-69 52.1	828600	30	REL	USE	--R--V-	5--3--1Z-	2--L--/-	BF	266.56	247.27	268.01	480	454	29	273.5	111.3	0.3							
3 26.0	43 49.8	-70 1.6	828600	30	REL	USE	--X--Z-	7--2--2Z-	2--Q+/-	BF	266.15	247.16	268.29	481	453	32	282.5	103.6	0.3							
3 27.0	43 46.8	-70 11.2	828600	30	REL	USE	--Z--T-	4--4--2Z-	2--Q+/-	BF	266.03	247.06	268.37	483	456	33	285.5	96.1	0.3							

TABLE 6. DATA SAMPLE FROM BENDIX ONS-20 EQUIPMENT



Dr. Friedrich H. Reder  
United States Army

BIOGRAPHY

Dr. Friedrich H. Reder, since 1963, has been a Research Physicist at the Center for Communications Systems, Fort Monmouth, New Jersey. He obtained his Ph.D. in Physics from Graz University in Austria. After studying gas discharge phenomena at M.I.T. for two years, he began to guide the development of Atomic Clocks at the Army Signal Corps Laboratories. Since 1963 he has been engaged in propagation studies for Data Distribution Systems, especially regarding effects on VLF navigation signals and VHF/SHF signals for data transmission.

\*\*\*\*\*

TECHNICAL PROBLEMS

Several important technical problems with the use of Omega for air navigation need solutions based on the kinds of information to be collected in a world-wide Omega data bank. These problems include modal interference, coverage holes, heavy solar activity, and antipodal interference. I offer the following

comments and suggestions about these problems.

MODAL INTERFERENCE. Modal interference is one of the worst difficulties, and perhaps the most important, because modal interference very frequently distorts the nighttime portion of diurnal phase patterns. It causes cycle jumps when the propagation flows westerly across the geomagnetic equator into the northwest and southwest sectors. This phenomenon is found in reference 7 which cites examples of modal interference along paths from Liberia to the United States and reference 8 which gives examples from Hawaii to Australia. In contrast, solar disturbances cause anomalies much less frequently.

In order to navigate with signals that are vulnerable to modal interference, the software in the avionics equipment is required to recognize which of the received frequencies will lead to a lane slip. Simultaneous tracking of signals at 10.2 and 13.6 kHz may be a sufficient basis for a correct solution during some seasons when modal phase anomalies do not occur nearly simultaneously on both frequencies.

Present knowledge leads me to plead again for the earliest test of a unique-frequency signal from Liberia, on any frequency between 15 and 18 kHz, to prove whether adding such a frequency can be a reliable tool for overcoming the modal interference problem during all seasons. Such a hope is based on recordings of Haiku, Hawaii (10.2, 13.6 kHz) and NPM (23.4 kHz) taken at Brisbane, Australia. While the nighttime phase of the Haiku 10.2 kHz signal is very unstable, the Haiku 13.6 kHz signal is better (reference 8), and the signal of NPM on 23.4 kHz is still better.

This problem will not go away by itself. As soon as possible, a determined effort is needed to find a solution. Movement of the transmitter from Liberia has been discussed. But, moving the Liberia transmitter to higher latitudes is neither economic nor will it solve the problem for all navigation areas (moving north improves propagation to USA, but not to South America; moving it south will do nothing for the USA problem and will worsen Omega geometry for the South Atlantic area).

A final comment on this problem: It would be helpful to find out which parameter(s) of the equatorial ionosphere cause these large variations in transequatorial VLF signals. Appropriate correlation studies over a year's period may lead to a clue.

COVERAGE HOLES. We know already that coverage is not good in parts of USA and Canada (so-called "Winnipeg Hole") and in the Southwest Pacific and Indian Ocean areas (reference 10).

We need a better definition of the boundaries of these coverage holes, if indeed they can be defined. This meeting has revealed considerable disagreement on the boundaries of the Winnipeg hole.

With respect to holes in the Pacific/Indian Ocean/Arabian Sea areas, much hope is placed on the new Australian transmitter. I am afraid, however, that poor geometry, near-field problems, and/or modal interference, where the Australian signals cross the geomagnetic equator in the northwest direction, will prevent removal of all coverage problems (reference 10).

HEAVY SOLAR ACTIVITY. In spite of increased solar activity in April/May 1978, you have not seen much yet. As a matter of fact, with respect to proton flares in the equivalent year 1967 of the previous cycle, 1978 solar activity was relatively modest until now. But this may change any time.

Radio reports that the X-ray flare of April 28, 1978 was the largest ever observed are unjustified. According to our VLF records, larger SID anomalies occurred on December 29, 1968, and March 12 and 17, 1969, and November 15, 1970.

However, in contrast to mode interference problems mentioned above, there is a rather good chance that software techniques, based on already existing 10.2 and 13.6 kHz correlation data for SID phase anomalies (reference 11), and onboard dispersion measurements will yield acceptable SID propagation corrections.

In view of possible communication blackouts during solar activity, the advantage of onboard-derived versus radio-transmitted corrections can hardly be overemphasized.

Because SID's usually have fast onsets and recoveries, may occur in rapid sequence, and appear on all sunlit paths, their onboard correction seems to be more important to general aviation than that of PCA anomalies which occur only on polar paths and take days to recover; preflight corrections can often be applied and will be valid for several hours of flight time. It must be remembered that when all received signals are affected concurrently by SID anomalies on all sunlit paths and are not eliminated, the error is less than when only one or two signals are so affected. Path lengths and average solar zenith angles will usually be so different that the SID effects are not equal for all signals.

ANTIPODAL INTERFERENCE. Antipodal interference produces signals at the receiver which have unstable phase and amplitude. Pure long-path signals have reversed diurnal-phase patterns.

The notion of a geographic antipode is quite meaningless for electromagnetic wave propagation. Nonreciprocity of propagation parameters due to the presence and alignment of the geomagnetic field reduces west to east below east to west propagation losses. There are two other factors contributing to the imbalance of losses along short and long paths. One is the different ground conductivities (less over land and over huge ice masses than over sea water). The other is due to height of the ionosphere which varies so that

losses usually are higher in daytime and lower in nighttime. Therefore, signals affected by antipodal interference must be deselected (e.g., Hawaii, in much of the Indian Ocean (reference 8), Japan, near the East African coast (reference 9), etc.). The effective antipode may be found 1,000 miles away from the geographic antipode.

The planned data bank program can contribute much to a better definition of the antipodal interference areas associated with Omega transmitters. Some seasonal variations of such areas must be expected.

#### DATA BANK OPERATIONS

A number of suggestions can be drawn from past experience to improve the planning and operation of an Omega data bank. Mutual benefits cannot be overemphasized for any project based on the cooperation of many parties.

The pilots will be most important contributors. Without their complete cooperation the project is doomed to failure. Consequently, they must derive some worthwhile benefit and they must be consulted in depth on what the project can give them in terms of data immediately useful for their job.

Data from many flights along fewer paths will be more meaningful than data from a few flights along each of many paths.

If economy and safety permit, it is better to record more than not enough parameters. Experience tells me that much too often during data analysis, one comes to the sad conclusion: "If we only had

measured that other parameter we thought we did not need." The other aspect is what you do not need, someone else may need.

It is desirable to measure simultaneously all useful signal parameters on all transmitted frequencies (important for reduction of radiation and mode-interference anomalies).

Simultaneous ground monitors should be carefully selected to match the chosen flightpaths. Somehow, air and ground monitors will need to be reconciled.

For ground monitors, analog recordings in addition to digital recordings are highly desirable for easy spotting of anomalous signal behavior. Also, it is essential that amplitude is recorded in addition to phase. A quick look at test recordings avoids a lot of wasted energy.

Always be suspicious of equipment tricks. Watch constancy of supply voltages, RFI, antenna effects; and, you may have to examine software. For example, the reported simultaneous large dips on SNR curves for all received signals on two North Atlantic flights (reference 12); and, the substantially lower SNR values shown for several 11 1/3 kHz signals versus the 10.2 and 13.6 kHz values are highly suspicious. (My first bet with respect to SNR dips would be supply-voltage variations when the pilot turned on additional equipment or 400 Hz power-line signal interference. With respect to the 11 1/3 kHz problem, the trouble could have been a calibration error. Other possibilities for SNR problems are noise level increases due to nearby thunderstorm activities.)

Keep fingers off knobs once all controls have been set and checked.

Keep good logs. Never rely on memory. Always note down exact GMT when something odd is noted.

#### OMEGA SIGNAL LOSSES ON TRANS-GREENLAND PATHS WHEN ICE CAP IS IN NIGHT

In the early part of this meeting, I raised the question whether anyone has noticed an amplitude improvement on trans-Greenland signals when the ice cap went into night conditions. The answer was negative.

However, our North Dakota signal recordings at Kiruna and Stockholm, Sweden, consistently indicate a gain of 30 dB when the ice cap enters the earth shadow and there is decent phase tracking during these hours of nighttime in Greenland.

The explanation for this obvious discrepancy between airline experience and our recordings may be the fact that Greenland remains sunlit 24 hours per day between the middle of April and the beginning of September. Greenland has only short night periods during an additional 2 months of the year. So, during 6 months of the year, this effect is not very noticeable. Our Scandinavian recordings were taken in early February and middle of October.

#### CONCLUSION

This has been a very profitable meeting and FAA should be congratulated for initiating the data base collection. I propose that another meeting should be organized soon, to discuss the most efficient

and affordable ways and means for analyzing/evaluating the data base for the benefit of an improved Omega navigation system appealing to the majority of users of this navigation aid.

REFERENCES

7. Reder, F., Letter Report No. 4, MIPR-Z-70099-6-61851, May 14, 1976.

8. Reder, F., Letter Report No. 5, March 16, 1977.

9. Reder, F., Letter Report No. 6, April 4, 1977.

10. Reder, F., Final Report, April 8, 1977.

11. Reder, F., Omega Navigation During High Solar Activity - Problems and Possible Solutions, Proc, International Omega Association Conference, Linthicum, MD, November 1977.

12. Rzonca, L., Data Bank Operations, this meeting, August 2, 1978.

## CONCEPT OF AN OMEGA DATA BANK

Joseph J. Scavullo  
Chairman

There are numerous concepts of a data bank. Going beyond the general concept and plans already presented, I make analogies to a money bank in which the officers strive to increase deposits for offering generous interest. In this case, the FAA is motivated to organize and operate a bank at NAFEC because of its requirements for engineering information. FAA does not (always) seem to be a bank. But it is accustomed to fiduciary responsibilities. It conducts its business to increase flight safety and enhance efficiency.

The fiduciary analogy is especially important to this bank. Operators, pilots, and manufacturers all have a stake in the bank. One operator had pointed out 2 years ago that pilots would object to addition of a tape recorder which might be applied to surveillance of their performance or to disciplinary measures. We have no interest in such applications. Some FAA people have pointed out that unless recorders were placed in all aircraft, there would be no basis for using our bank's few recorders for disciplinary purposes. Airlines have urged us to write agreements with participants in which a stipulation would prevent FAA from using the flight records in any way for discipline of flight crews.

A letter has been received from Capital Airways (Capital Air Sales) which offers to participate. It suggests several paragraphs for its agreement with NAFEC. One provision covers the estoppel against use of the bank for flightcrew discipline. Another seeks assurance that the recorders will not derogate the flight safety or performance of the aircraft. Anonymity was also to be maintained. This raises a question how experience of the operators can be shared without violation of their anonymity; clearly this matter will challenge the imagination, resourcefulness, and integrity of the bank. We may not misuse, embezzle, or waste our depositors assets. Yet we need to show appreciation in each account. And much interest will be generated by the strength that inputs from numerous deposits of data alone can give.

Question (Dr. Reder) Will the bank make regular reports to the IRS?

Response (Scavullo) It would be only just to require IRS to read our Omega reports!

Thus, participants may expect us to take our fiduciary responsibilities

seriously. We may spend nearly 2 million dollars over the next few years on long distance navigation projects and much of it will be spent on the bank. We have already invested much capital so we have an excellent set of assets with which to begin operations. We will take in your data, manage it honorably for your benefit, and that of the world's aviation community. Whereas,

we will provide the salaries for six or seven members of my staff, and secure much support from within NAFEC, we may find an operator which cannot provide its own interface kits; we will try to finance one. However, new money may be difficult for us too. We hope that the bank and its participants will share the work and the expense as already outlined for everybody's benefit.



Robert Erikson  
Federal Aviation Administration

BIOGRAPHY

Mr. Robert Erikson is currently involved in engineering work related to research, evaluation, and installation of airborne LORAN-C and Omega Navigation Systems. His NAFEC career began in 1971 as a member of the Student Cooperative Program and continued following his graduation from Drexel University in 1973 with a Bachelor of Science in Electronic Engineering. His work on Omega projects has resulted in a Report entitled *Testing the Feasibility of Differential Omega for Airborne Use*. He has also engineered the requirement for the Omega recording and interfacing equipment to be used with this world-wide Omega Data Bank.

\*\*\*\*\*

An automatic recorder is essential if we are to obtain in-flight Omega data recordings. Without such a recorder, information would be available only in limited quantities through courtesy of the flight crews. Systematic data collection would

require assignment of a person onboard the aircraft solely to observe and write down the facts. The integrity of hand copied data is always somewhat suspect and cannot be directly processed by machine. Data analysis would be inefficient and the overall integrity of data bank operations would become questionable. Thus, automation is regarded as essential to the expeditious collection and processing of Omega data.

Mechanization of a data collection system could have been based on audio recorders, multitrack digital tape recorders, data cartridges, floppy disks, or digital cassette recorders. Size, weight, power requirements, and form factor precluded most of these data collection methods. The audio recorder does not have the required capacity, data rate is low and vulnerable to errors due to erratic speed changes caused by line voltage to the recorder and/or line frequency. The data cartridge and digital cassette recorder can be packaged conveniently and has met all of our requirements to date.

A portable recorder package (figure 21) containing a tape-cassette deck was developed at NAFEC and manufactured by Raymond Engineering, Incorporated. We have carried it aboard commercial aircraft, plugged it into the power line, and connected three coaxial data lines to collect data from the airborne Omega equipment. The method was convenient and successful when connected for recording both Litton and Dynell equipment.

Several difficulties arose due to the portable nature of the equipment. Mainly, where do you store it when not in use, and the possibility that security officials might think it contains a bomb.

Knowing the format of a data stream permitted us to organize the digital signals in memory, record them in a systematic method on the cassette, and process them by machine after the flight. Printouts (table 7) were obtained giving in two consecutive lines across the page, the date, Omega station useage, SNR's on 10.2 kHz, phase corrections computed internally, present latitude and longitude, and other navigational data. Date and time of day for the sample were cited once for each set of two lines. Sampling was at intervals of 1 minute throughout the flight. Much less than one side of the cassette was enough tape to cover 8 hours of sampling.

An ARINC three-quarter ATR short box (figure 22) was selected to house the next data collection system with a built-in cassette recorder. This unit was manufactured by Bendix for use with the Bendix ONS-20 Omega set.

We have flown such a box with the same Raymond Engineering cassette transport in several FAA airplanes. The box is full. There is no room for the addition of any extra circuitry for interfacing. However, the ONS-20 functions well with the recorders. A special printout of the data available from a single sample is shown in table 8.

Most of the entries labeled in engineering units are self-explanatory and easily examined. These labels include the following: date, time, present position, waypoints from and to, position at waypoint switch, true airspeed, ground speed, wind velocity and direction, desired track, track, magnetic heading, magnetic variation, distance to go, along-track distance, and crosstrack distance. "Station status in normal" means geometry is suitable for navigation using the stations indicated. "Relaxed mode" indicates need for caution as the system recognizes that the geometry is not the best with respect to the available stations. "Propagation status" shows whether propagation conditions have been predicted which could make signals from a station useable; those absent have been deselected. The three Omega frequencies should indicate that the Omega set is using 10.2, 13.6, and 11.3 kHz for navigation. Different frequencies would be shown during a relaning procedure.

A warning word of 16 bits shows when an internal failure has been detected and which of 16 different failure categories have been recognized. Signal-to-noise data is not shown directly. The Bendix equipment works with signal quality

numbers from 0 to 10, but SNR is not directly recorded. Propagation corrections shown were calculated internally to the Omega set.

SNR data shown in figure 23 was collected during a trip in the CV-880 from San Juan, Puerto Rico to Bermuda. Signal quality values are given from 0 to 10 as ordinates and time (GMT) as the abscissa. The curve is for signals from Norway. In the Bendix receiver, a signal quality number of 0.5 represents a design threshold SNR of -20 dB. A value of 10 represents a SNR of +6 dB.

Question (Dr. Reder) Why is the signal quality on 11.3 kHz lower than 10.2 kHz and 13.6 kHz?

Response (Erikson) This was a quick dump of the data and is presented as an example of what may be recovered. I do not know why 11.3 kHz is worse than 10.2 kHz. We see, however, how the quality of three frequencies from all stations may be collected and reconstructed quickly by this method.

What have we learned by such recordings that can help us specify a recorder for the data bank? We know we need a recorder with flexibility, permanently installed in the aircraft, automatically turned on and off with the Omega sets, and record up to 24 hours of flight time so that cassettes need be changed only at a designated terminal. We should standardize the recording format of digital information on the tape. Digital signals are easily converted from one arrangement to another by machine. If the data format on tape is not consistent, much effort must go into hardware. We need space for interfacing and buffering the

the outputs from various Omega sets. We prefer to avoid, as much as possible, modifying any model of Omega so as to sample the selected digital data. We must not change the basic purpose of the Omega navigation set which is, of course, to navigate.

There are different schemes available to output digital data. All desired data may be incorporated in a single line, or divided on two lines, or on three lines. The buffer space we have requested will allow us to accept any of these schemes. ARINC Characteristic 580 makes no provision for data output. Tracor Systems has a data output board for its production equipment. Canadian Marconi needs to make little or no hardware change to its memory board; only software changes are needed to deliver what we need at the CDU. The Litton equipment is designed to produce useable output with no Omega modifications. The ARINC 599 equipment will produce data at a standard output. A custom circuit board will be required in the recorder for each of these system.

A user area has been requested for four custom boards, 4 1/2 by 4 1/2 inches. These may be printed-circuit boards or they may be wire-wrapped. Data from the Omega set will enter the user area passing through some type of isolation and line receiver. If the recorder fails, or power goes off, the event will not be reflected back to the Omega. Control signals from this user area include buffer enable which allows the buffer unit to store the data while clock and data are input. Once the buffer enable returns to the invalid state, recording of the buffered data on tape is initiated.

We have provided only for four sizes of data sample. Storage is organized to assemble 512, 1024, 1536, or 2048 bits. Shorter records will only use part of this memory while longer records can be divided into two parts, but this standard simplifies the playback services at NAFEC. The transport is controlled entirely by the electronics supplied in the recorder.

What is on the tape? The tape contains an American National Standard Institute (ANSI) preamble of the "AA Hex" code, cyclic redundancy check, and the post-amble plus inter-record gap. We write data only on one track encoded as biphasic level while the second track is occupied by a signal for the cassette tape deck. To the operator and user, this internal arrangement of the data format and buffer does not mean much.

The cassette loads through the front panel of the 3/4 ATR box. An initialize button sets up the tape. No other operator action is required until the cassette has to be removed.

Once the data has been recorded, how will it be recovered? The loaded data cassette is processed through a converter which transfers the data onto a 9-track tape, ready for the Honeywell 66/60.

Participants need not employ our recorder. Data may be recorded otherways and delivered to use on 9-track tape which is IBM compatible, or we can take your tape cassette with data arranged in the standard format and transcribe it.

The present playback unit encompasses a cassette transport, a converter from phase encoded signals to nonreturn-to-zero with both data and clock, a cyclic redundancy checker which passes good data and rejects bad, serial-to-parallel converter, and control circuitry. The buffer unit and control circuits can convert a complete cassette to 9-track in about 20 minutes. If a stream of 1,024 bits per sample are recorded once per minute, the tape should run for an elapsed time of 24 hours. If more samples or more bits per sample are recorded, the recording time of the cassette will decrease since the tape has finite capacity.

These were the salient engineering requirements given to Base Ten Systems, Inc. the manufacturer of the Airborne Interface And Recording Set shown in figure 24. (Note: See appendix B for Mr. Erikson's response to questions from the conferees.)

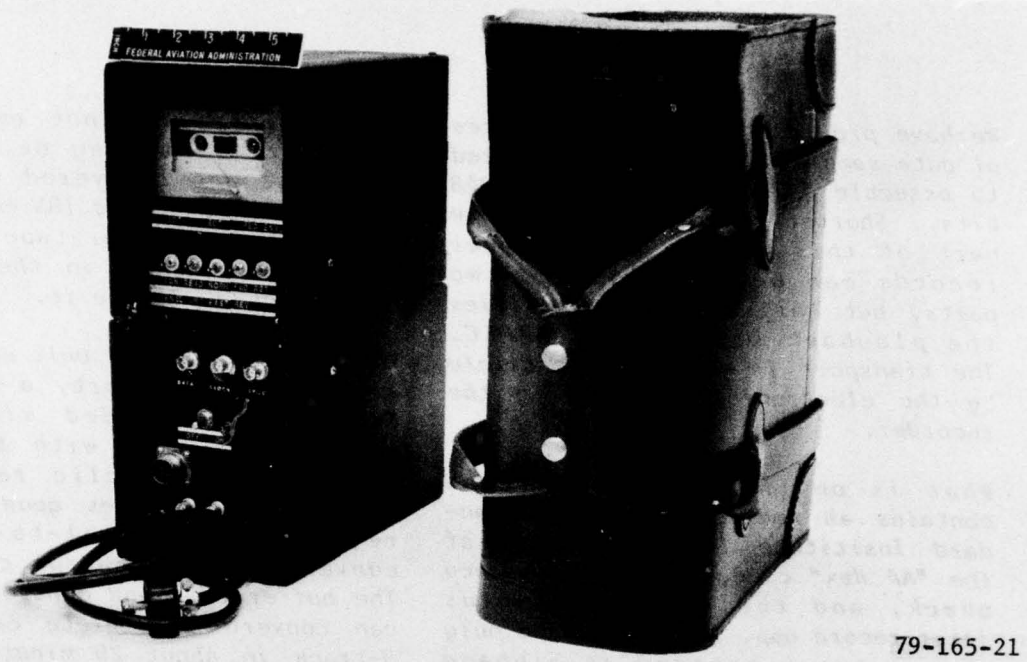

*FIGURE 21. PORTABLE RECORDER WITH MODEL 6106/6406 TAPE DECK MANUFACTURED BY RAYMOND ENGINEERING, INC.*

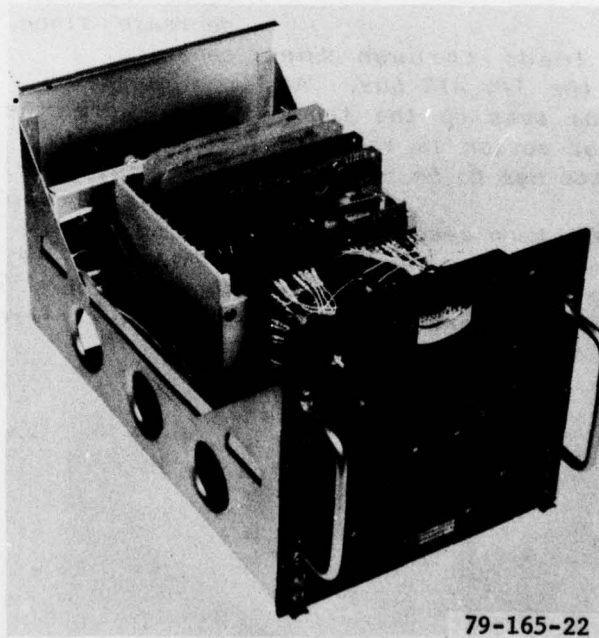

*FIGURE 22. THREE-QUARTER ATR SHORT RACK CONTAINING RAYMOND ENGINEERING'S INCREMENTAL CASSETTE RECORDER AND THE ASSOCIATED CONTROL ELECTRONICS MANUFACTURED BY BENDIX*

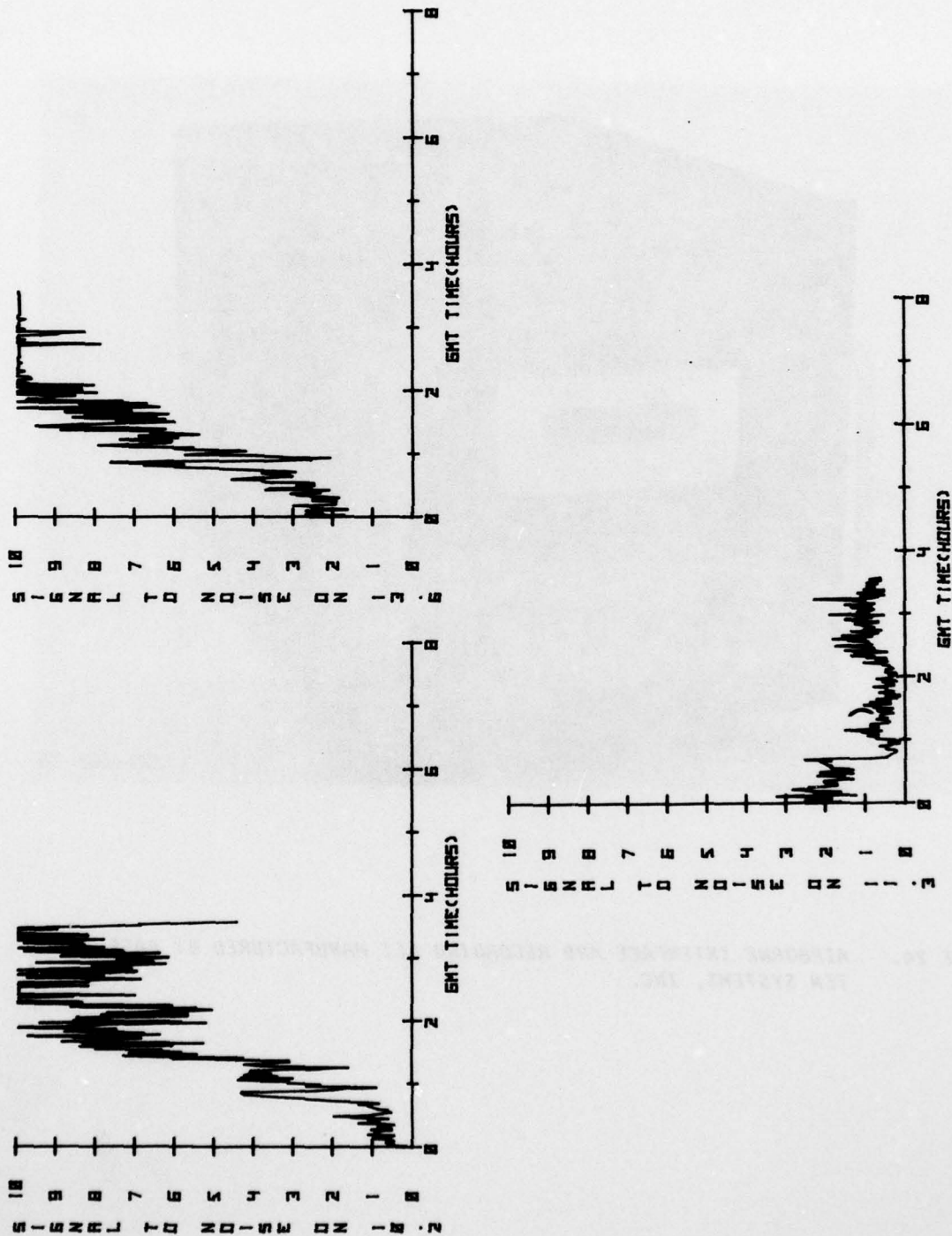
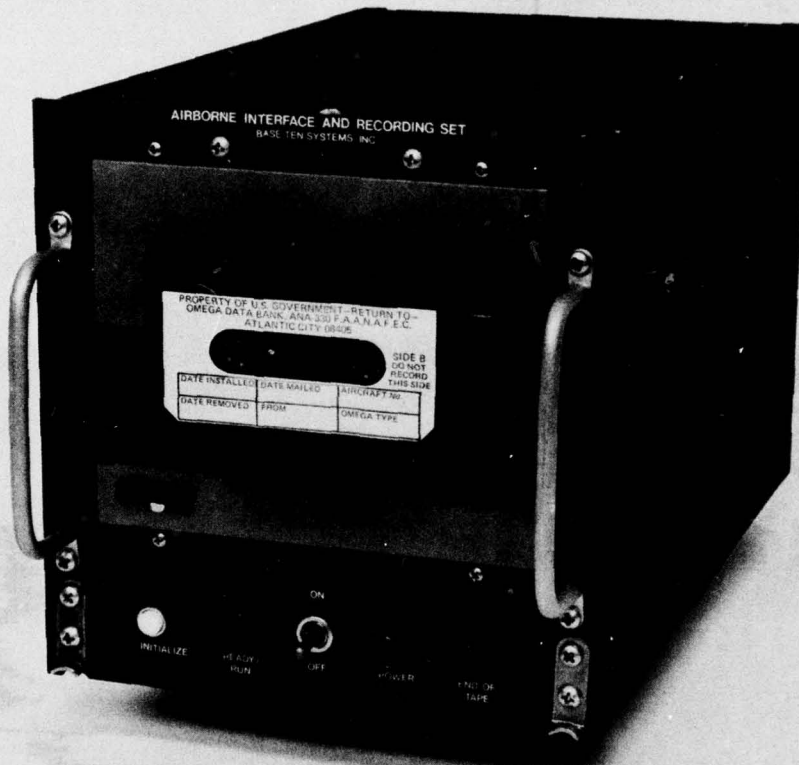

FIGURE 23. SIGNAL-TO-NOISE GRAPHIC DATA, STATION NORWAY, JULY 19, 1978  
OBTAINED WHILE EN ROUTE FROM SAN JUAN, PUERTO RICO TO BERMUDA



79-165-24

**FIGURE 24. AIRBORNE INTERFACE AND RECORDING SET MANUFACTURED BY BASE TEN SYSTEMS, INC.**



THIS PAGE IS BEST QUALITY FRAGMENT  
FROM COPY FURNISHED TO DQA

\*\*\*\*\*

127 255 15 13 11 180 13 135 202 234  
127 255 15 13 11 180 13 135 202 234

DATE(dmy) 19 7 1978 TIME(hms) 2 11 40 PRES POS (dm) N 19 1.4 W 74 39.1  
WAYPOINT FROM N 19 9.9 W 72 50.0 TO N 18 59.7 W 75 10.1  
POS AT SWITCH N 78 1.4 W 72 48.7  
IAS(kts) 469.6 GND SP(kts) 450.2 WND VEL(kts) 20.3 WND DIR(deg) 287.6  
DSR TK(deg) 265.5 TK(deg) 272.1 MHDG(deg) 272.8 MAG VAR(deg) -2.9  
DTG(mm) 29.3 ALTD(mm) 29.3 XTK(mm) 0.6

STATION STATUS

NORMAL RELAXED  
10.2 A-CD--G- A-CD--G-  
13.6 A-CD-FG- A-CD-FG-  
11.3 A-CD--G- A-CD--G-

Prop Status A-CDEFGH

FREQUENCY USAGE 10.2 13.6 11.3

WARNING WORD 0

SIGNAL TO NOISE

	A	B	C	D	E	F	G	H
10.2	4.30	0.63	6.72	9.92	0.08	0.16	3.83	0.00
13.6	9.92	0.70	7.73	9.92	0.08	0.39	9.92	0.00
11.3	0.86	0.16	0.94	4.14	0.00	0.00	1.88	0.00
PROPAGATION CORRECTIONS								
10.2	3.63	3.95	3.88	3.89	3.94	3.92	3.98	3.31
13.6	0.58	0.22	0.22	1.16	0.63	0.14	0.27	0.30
11.3	0.75	0.45	2.11	1.06	0.23	1.11	0.78	1.02

\*\*\*\*\*

TABLE 8. SAMPLE DATA MESSAGE FROM BENDIX ONS-20 TO IN-FLIGHT CASSETTE RECORDER

A CASSETTE TAPE RECORDER FOR  
AIRBORNE OMEGA DATA



*John Pohlke  
Base Ten Systems,  
Incorporated*

BIOGRAPHY

*Mr. John Pohlke is Engineering Manager for Base Ten Systems, Inc. His company is a small business with considerable experience in design and manufacture of both commercial and government products. Mr. Pohlke will describe the airborne recorder and interface equipment which has been built to satisfy the engineering requirements prepared by Robert Erikson.*

\*\*\*\*\*

*As a prelude to a general overview of the equipment, let me mention that the equipment was designed to meet NAFEC engineering requirements (see appendix C, Technical Details) and it reflects much of what we at Base Ten Systems have learned over the years. For those who are not familiar with the company, you should know that we have packaged airborne instrumentation systems for about 12 years. More recently, we have manufactured other avionics, particularly in the weapons control area. There are features in the recorder I'm sure you are all interested in such as the*

*validity of our design with respect to such factors of the airborne environment as shock and vibration, temperatures, power sources, and the like.*

*As Bob Erikson told you, the package is a standard 3/4 ATR box, short; it is 7.6 inches wide, 7.8 inches high, and 12.5 inches long. The package contains an MFE 250B digital cassette tape recorder, two Lambda power supplies, a control card, a memory buffer card, and wired positions for user interface cards. The package is more or less totally dependent on these interface cards to accomplish useful functions.*

*The internal power supplies provide +12 and +5 volts. The latter supply produces 5 amperes of which 1.5 amperes are consumed by the tape recorder and the control electronics so that about 3.5 amperes are available for delivery to the interface cards. The +12 volt supply is not used internally by us and will deliver some 400 mils for delivery to the interface cards. The -12 volt supply contributes 125 mils to the recorder system, leaving 272 mils for the interface cards.*

Space for the interface cards are laid out here to accept four three-layer, wire-wrapped interface cards. However, there is some extra space and holes are provided in the printed circuit mother-board for addition of three more mating connectors so that three additional cards positions can be established. If all the cards were printed and not wire-wrapped, seven cards could be installed. Mating six connectors have 70 contacts, 26 pins of which are bused across to the main interface connector at the back of the box.

The device is rated for operation over the range from 0° to 55° Centigrade (C). To insure that no damage is done to the tape during exposure to temperatures outside that range, two thermostats are in series with the incoming power and do not allow the device to be turned on until operating range of temperature has been achieved. Main power also enters via a 2-ampere circuit breaker part of the on-off switch at the front panel.

On the face of the box, there is a light button called Initialize. After a cassette has been loaded into the recorder and power applied, operation of the initialize button will operate the tape all the way to one and where it will rest on a portion of the clear leader. A red lamp at the left side of the panel indicates that the recorder is on clear leaders. The tape then reverses until magnetic tape is positioned ready to take data. At that point, a green light at the right of the power switch indicates ready to take data. A green LED lamp to the left of the power switch indicates that the unit is powered up.

The unit has a buffer memory card with capacity for 2,048 bits. The memory is internally programmable in chunks of 512 bits so there are four increments to work with. Memory is a standard RAM, type 21L02, available from several manufacturers. The device requires three input signals to get data onto the tape: buffer enable, clock, and data.

In operation, whenever buffer enable is true (or high) data will enter buffer storage on positive edges of the input clock cycle. At such time as memory has become full to the selected programmable capacity, or at such time as you chose to record a block of information by dropping the enable line through a false zero condition, the complete memory will fast fill up with zeroes and then write the data onto the tape. First the memory writes a 90-millisecond high gap onto the tape, then lay down a double A hexadecimal preamble, then the complete block of data will be dumped onto tape. A cyclical redundancy check character will follow the data dump and the writing will conclude with a double A hexadecimal postamble. Then the buffer begins to load again as directed for the next sample. During the initialize cycle, a 50 kHz clock writes all zeroes into the RAM to clear the memory of residuals.

The package weighs 14.6 pounds. The tape in the cassette is 300 feet long, of which some 282 feet are useable for recording. The tape has capacity for recording about 2.88 megabits. We are recording at about 800 bits per inch.

Question (Carmel) Does the recorder come with mounting trays?

AD-A069 474

NATIONAL AVIATION FACILITIES EXPERIMENTAL CENTER ATL--ETC F/6 17/7  
PROCEEDINGS OF THE WORLD-WIDE OMEGA DATA BANK CONFERENCE HELD 2--ETC(U)  
APR 79 J J SCAVULLO, J M DAVIS, G H QUINN

UNCLASSIFIED

FAA-NA-79-165

NL

2 OF 2

AD  
A069474



END  
DATE  
FILMED  
7 -79  
DDC

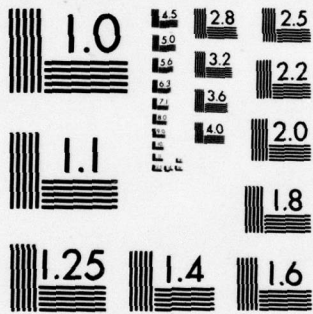

MICROCOPY RESOLUTION TEST CHART  
NATIONAL BUREAU OF STANDARDS-1963-A

Response (Scavullo) NAFEC has ordered 16 mounting trays for issue with recorders if needed. Shock mounts are provided with the trays along with suitable cable connector ready for assembly.

Comments (Pohlke) As long as shock and vibration do not exceed the NAFEC specs, the unit will operate without shock and vibration mounts. (Engineering requirements referred to the ARINC 580 characteristics and its subsidiary specification for guidance.)

Input power to the package can be 105 to 125V from 50 to 440 Hz a.c. power. Should the cover be removed, all access to line potential is guarded by covers or placement within the package.

Question (Scavullo) The Omega manufacturers have sealed their boxes. This one is full of ventilation holes. Can anyone suggest what practical temperatures we may have to experience?

Response (Pohlke) We have had experience with the MFE-250B recorder in U.S. Navy equipment. An instrument package was engineered for parachute drop into ocean water to record sonar signals. It has to be retrieved and be operable. Extensive tests were conducted by the Navy against stringent specs. The recorder is also available to operate to extended environmental limits, in a range of -40° to +70°C. Tape also is available to endure -40° to +70°C. Our internal logic, although CMOS logic designed to withstand

primarily to 0° to +55°C, could be revised to withstand -55° to +125°C. The power supplies would also need replacement to withstand temperatures higher than +55°C. Power goes immediately from the on-off switch and circuit breaker to the thermostats.

Comment (Carmel) If temperatures around the avionics reach +55°C, there won't be anything to record because the Omegas will stop functioning. How much heat does the unit dissipate into the aircraft?

Response (Pohlke) This device normally takes about 1 ampere of current or less.

Question (Lanoue) What type of power is provided in the recorder?

Response (Pohlke) As I said earlier, there are three voltages available for the interface cards. One at +5 volts can offer 3.5 amperes, a +12 volt supply furnishes 400 milli-amperes, and the -12 volts supply can deliver 275 milliamperes. Assuming interface cards are based on CMOS technology, there should be more than adequate power available.

Question (Huhn) Did you run any EMI tests into the aircraft?

Response (Pohlke) No. The power supplies are not switching supplies. NAFEC specifically excluded them as possible sources of EMI. The box was designed to good EMI practice.

Comment (Scavullo) We are going to have to assure all concerned that the recorder will not produce EMI in the aircraft.

MODIFICATION KIT FOR DIGITAL DATA RECORDING  
FROM OMEGA NAVIGATION SET CMA-740



*Dr. Jean-Claude Lanoue  
Canadian Marconi Company*

BIOGRAPHY

*Dr. Jean-Claude Lanoue is a project engineer for Canadian Marconi Company involved in the development of VLF navigation systems. He is largely responsible for the development of the software which has led to the success of the CMA-740 airborne receiver. Born in France, he graduated from Lyon in 1967, obtained a Ph.D. in electronics in 1970, and worked on communication and data acquisition systems at Notre Dame Hospital in Montreal until 1972.*

\*\*\*\*\*

*A method was described for supplying digitized output data from the Canadian Marconi Company's Omega Navigation Set, Model CMA-740. By means of revised software in the Receiver Processor Unit (RPU), data output from the main memory board will be reorganized and augmented for delivery on the same two-wire circuit connecting the Receiver Processor Unit to the Control Display Unit (CDU). The*

*interface, buffer storage, and cassette tape deck, all in a separate box, are accessed to the desired data by tapping the RPU and CDU circuits.*

*The presentation described the interconnection, the interface requirement, and salient specifications for the Digital Data Source, Data Burst Coding, and Frame Coding. Some of the parameters which change slowly were to be delivered at 60 second sampling rates while some others were to be sampled every 10 seconds. While most of the organization was to be accomplished in the CMA-740, the paper outlined a compatible interface for the airborne recorder system. Users wanting to record from a standard CMA-740 equipment could exchange a memory board for another having the new software. The exchange can be accomplished at a service center authorized by Canadian Marconi Company.*

*Appendix C contains the revised technical proposal with all the details of the CMA-740 modification kit.*

DIGITAL DATA RECORDINGS FROM  
TRACOR MODEL 599R OMEGA SETS

Terry Armstrong  
Tracor, Incorporated

Mr. Terry Armstrong, Tracor, Inc., has undertaken to inform us about the method of providing FAA and other customers with a means of digital data recording during test of the Tracor Model 599R airborne Omega receiver.

\*\*\*\*\*

Tracor has signed an agreement with NAFEC for a digital input/output (I/O) board to be installed in the receiver processor unit. Also required is an interface board in the recorder. We also will supply a software package for retrieval of the data from the cassette tape.

The RPU has a software package already which puts out an Frequency Shift Keyed (FSK) signal to a recorder. In the past, we have used voice recorders with little success because the voice recorder was not a reliable method. To modify the RPU for digital data output, our standard optional I/O card is needed. Customers which did not opt to have this card installed at the factory will need to have a mod added before connection to the recorder.

The standard card does some other things. It outputs a 6-wire Binary Coded Decimal (BCD) distance to go for cross loading dual Omegas, remote

loading dual Omegas, two-wire binary output of ground speed or present position to an area-navigation system. It will also give this data capability to a digital recorder.

When this digital I/O card is inserted into the RPU, it changes the part number on the box. The box with the I/O card already in it is a TSO'd box. It is a standard option. Many corporate users already have this digital card in their RPU. They like the 6-wire BCD "distance to go."

Transmission of the FSK signal to the recorder will be via a shielded twisted pair. Transmission is always at 10-second intervals. Sampling rate will be determined at the interface card in the recorder. It can be counted down to one frame per minute, one in two minutes, or whatever.

I'd like to go over a few parts of the homework test we took yesterday. I think we passed. In the handout there was "Airborne Data from Omega Data Bank" and I was to check what we expected to provide the Omega navigator. We provide everything except Waypoint From and Waypoint To. This software package could be changed, but we left it out as it did not seem to be relevant.

Our Omega does not put out SNR but instead we furnish a signal quality code in numbers ranging from 0 to 999, the higher the better. They are only figured on the 10.2 and 13.6 kHz signals. We only display and output the lowest number. If the 10.2 kHz signal has the lowest signal quality, that's the number that will be displayed. It can be translated into SNR, but we will not be able to tell you which of the two frequencies the quality number pertains to.

We do put out the phase measurement for all three frequencies.

Question (Carmel) Isn't that (SNR) the primary requirement of the data bank?

Response (Armstrong) Well, they asked us to output certain things. We proposed to do what could be done without major modification to the box. We were subject to severe cost restraints.

Comment (Scavullo) We have not yet figured out the impact of that compromise. We had only one alternative at the time of the order--that was to buy nothing!

Tracor is developing a VLF option and we expect to output all the information about the VLF signals when the option is available. The major point, though, is the simplicity of the modification to the RPU, i.e., merely dropping in a standard optional board, a TSO'd board. It just requires a shielded twisted pair running from the rear connector of the RPU, pins 42 and 43, over to the recorder.

Question (Scavullo) What would happen to our purchase order if we asked for addition of waypoints FROM and TO?

Response (Armstrong) I think we can get that information by tapping into the line between RPU and CDU.

Question (Scavullo) The other problem that remains is at which frequency is the quality low at any given time?

Response (Armstrong) We are looking at that but have no answer.

Comment (Scavullo) Thank you, Terry. This morning's discussion has been very satisfying. All who may wish to work with us or who can help us organize and operate the data bank, are invited to the closing business session at 1:30 p.m.

ESTABLISHMENT OF THE OMEGA  
DATA BANK AT NAFEC

Joseph J. Scavullo  
Chairman

Welcome to the business portion of our meeting. The work done at NAFEC to adapt Omega and VLF for air navigation has, over the 12 years prior to 1976, been at a low key. Salaries of perhaps two technical persons, on the average, have been the major expense together with nominal costs of installation and flight test of borrowed or breadboard equipment. The total expense for Omega projects up to 1978 may have been one million dollars. During the years 1978-1979, there will probably be spent another million dollars. Maintenance of the present team of up to 8 persons, with all the things they can do to consume material resources, has to constitute a major expenditure for the advantage of the aviation industry.

Personnel resources directly associated with the Bank at NAFEC at this time include: Dr. Rzonca, Physicist; Robert Erikson and Arthur Heavener, Electronics Engineers; and Richard Ohman, Air Traffic Control Specialist. Two journeyman Electronics Technicians, Leonard Pschirer and Thomas Wisser, who have flown flight inspection aircraft over much of the world, are also assigned. All are knowledgeable about the airborne operational environment. All believe with me in the validity of this project. You in turn have much knowledge and expertise upon which we hope to draw regarding the real world as it exists during your airborne operations.

As the first major investment, we have secured the engineering of the Omega data recorder, purchased 20 recorders, and with each have obtained 20 compatible cassettes. Data identity labels (figure 25) are affixed to each of the cassettes.

Cassettes are available on the market for about \$8.50. If we find the cassette records worth keeping, we will buy enough new cassettes in Fiscal Year 1979 so we may retain the raw data on them. If we can store the data on 9-track tape, we may recycle cassettes after each transcription. Records will be retained in some form for at least 2 years. The last operation of the bank may well be to run all data in a final pass through the computer for overall statistical analyses.

The Honeywell 66/60 computer came on stream at NAFEC last spring. Programs have been converted to it from files of the IBM machine it has replaced. Processing of bulk data for the bank should not become a difficulty.

It's been said by an advisor that some airlines are unable to control the security of their avionics equipment. Disappearance of equipment in far away places makes necessary the deployment of operational spares to overseas depots. I cannot offer an unlimited supply of these recorders. They cost our account some \$5,000. each; that is what will be charged to me when I

have signed a receipt for one and lose it. The record will show the value of equipment when it is turned over to the participant. Our contracting officer will know how to provide in an agreement for liabilities. It appears likely that the reasonable care required of the participating operator will not exceed the care normally taken to safeguard the avionics equipment already installed in the aircraft.

Airlines and other operators may soon be able to buy Omega sets with provisions for digital readout of the data we want. NAFEC has ordered the design and provision of modification kits from Canadian Marconi and Tracor and expects the same from at least Bendix and Norden Systems. NAFEC is not acquainted with the design details either of the hardware or the software in the ONS equipment. We will not break the seals. Therefore, the kits will have to be installed by whoever has been qualified by the ONS manufacturer. Thus, the warranty will not be compromised. Operators who order the digital readout option with original equipment, may not have to pay extra for it if NAFEC has already covered the non-recurring costs.

Mr. Pohlke's equipment, which contains only two parts that move mechanically, should last more than 2 years. The tape deck is said to operate an average of 15,000 hours between failures. Along with the recorder, we will supply a mounting tray, multipin cable connector, and a starting quantity of 20 compatible tape cassettes. We will try to secure additional cassettes, hoping to receive back one each week for up to 2 years.

Eventually, we expect some operators with Omega data will offer it to us, but will not use our digital recorder. As long as we can process the data, it will be welcome. Records on IBM-compatible, 7-or 9-track tape will be acceptable. We also seek cockpit scratch-pad notes to accompany the tapes. Any event noted by a pilot can have enormous value if the time of occurrence and data correlate with the digital records.

Operations throughout the world's airspace are possible in many aircraft over which FAA, at some point, has jurisdiction. Our regulatory duties are the underlying basis of this technical data bank. We need to know how the Omega propagation affects navigation over world routes of commercial and industrial interest under "normal" (natural) operating conditions.

Our first customer is Capital International Airways with which we have an agreement covering three recorders tied to Tracor equipment. (Appendix E delineates the format and scope of the interorganization participation agreement.) Other airlines with overseas routes will enter the bank later. Foreign carriers perhaps can cover parts of the world where U.S. carriers do not operate. Charter aircraft, with more route diversity, will produce data of different value than those flying the same routes many times. If we get 16 installations in active aircraft, it is likely that one or two will be aloft at all times. Its a small number of recorders, but probably as many as are reasonable at this point in the program.

Information of most value may be that recorded in regions of weak signals or environmental interference. The data shown by Dr. Rzonca included a plot on which the decaying signal-to-noise ratio curve matched very well the laws applying to the change of energy density with radius from the transmitter. Trinidad signals, at 1000 watts, evidently behaved as they should. Eventually, we may learn to attenuate signals so that our SNR records will be interpretable in terms of unsaturated signal levels.

While the data bank is being organized to help FAA carry out part of its mission, that is to help industry navigate with safety and efficiency, there are a number of advantages also to manufacturers and operators. We expect to provide a quick turnaround once a cassette is received. Of course, processing will have to be worked out. But then, a printout, or a special tape will be made available to the participant for study by its vendor. The reports we publish will contain mostly propagation-oriented records so that privacy is maintained. Some vendors may never be able to perfect software without these records. There is no objection to recording more data (in company code if need be) once the basic data FAA needs has been taken. From time to time the recorders may also be used for multiple systems such as two of the same Omega sets, and an inertial navigator, several different Omega sets, or other digital systems, provided sampling rates and some of the information content is useful in the bank.

In the long run, assuming all the recordings show that only trivial problems are encountered with Omega,

even during the upcoming peak in solar activity, the effort will have been worthwhile in establishing that neither the government, the operators, nor the manufacturers failed to take reasonable precautions to assure that Omega navigation is as safe as it should be.

Question (Carmel) Continental Can may already have learned what is needs to know about Omega, but it would agree to help FAA if asked. What distribution will be made of the 20 recorders? Will it take so long we may lose interest?

Response (Scavullo) NAFEC needs two recorders for its own projects, a laboratory model for test of changes or redesign, and a fourth as a spare to keep the others backed up. Of the remaining 16, two to four would be allocated to corporate aircraft, six to eight for scheduled carrier aircraft, and six to non-schedule aircraft. Of course, we will encourage participation, so that pattern may vary. Our agreements will allow either party to discontinue by mutual understanding. If the program succeeds, we will know we did not buy enough recorders; if the program fails, we will quietly remove the recorders and take a low profile. It is entirely possible that experience with the recorders will lead to demand for more of them. We probably would refer inquiries to the manufacturer, Base Ten Systems, Inc.

Comment (Fretwell) Airline Pilots Association (ALPA) would have no objection to the taking of Omega data, but would like agreements to state that flight safety will not be less by doing so and that the recorded data will not be used by FAA for disciplinary purposes.

Response (Scavullo) Our agreement with Capital has such provisions and so will the others.

Question (Carmel) Will the National Transportation Safety Board (NTSB) have access through court orders, etc.?

Response (Scavullo) FAA may not speak for the courts in matters such as civil litigation. Our agreement will only go as far as the law provides.

Question (Carmel) Have there been any provisions for approval of the recorder installation?

Response (Scavullo) Base Ten Systems, Inc. has not been required to perform a complete environmental check. NAFEC intends to make an EMI check. NAFEC cannot approve the installation--an inspector must do it.

Discussion (Various) The key to getting approval is to have manufacturers provide test documentation to facilitate certification of the Omega box. No TSO is required for approval of the installation. But after the digital output mod has been introduced, Omega receiver manufacturers should declare the original TSO not violated or derogated by the mod, present a manual or other description, some test data, and the test method.

The main points to cover in documentation are freedom from hazard to the aircraft and interference to the Omega set or other aircraft systems. It would be very easy if NAFEC supplied the recorder with a letter stating it had been tested by the manufacturer to RTCA-DO-138. The local inspector will recognize that

the recorder is not part of the aircraft system. There are bulletins which cover the fact that the unit is to be fastened to the aircraft. A letter by NAFEC, covering what has been done, that its a "one time" installation, should satisfy the local inspector. The airline may want an STC backed up by extensive testing. If we go to the trouble of an STC, perhaps it will be applicable to all the recorder installations.

The local inspector may be satisfied with a simple, functional flight test in which he will look mostly for the obvious. Airlines have working relationships with local air carrier district offices under which more or less reliance is placed on the engineering and procedures in practice at the site. In any case, it is important to keep FAA inspectors informed even though the operator does the work.

Comment (Scavullo) Of course, we would need production Omega with the digital output mods to do tests in NAFEC aircraft; we don't own such equipment. Perhaps the manufacturers will help us with suitable documentation.

Comment (Gibbs) Approvals seem to be a straightforward matter, an engineering change procedure is available. No problem is seen for the Omega receiver manufacturer. The Omega manufacturer is not responsible for the recorder.

Response (Scavullo) We can arrange loan of a recorder to the Omega manufacturer for trials in the plant along with the data-output mod. Bob Erikson will test the recorder at NAFEC.

Question (Lanoue) Who will provide the interface cards for the recorder?

Response (Scavullo) If we only need one, Erikson will design and build it. If we need several, we probably would have Base Ten or some other manufacturer do them. Prospective users of the recorder may consider how they want to participate and may have special interfacing done in the recorder so they can collect data other than what FAA would need. We will not exchange funds with participants.

A sample of the first agreement with Capital is available. Under it, FAA provides the recorder, mod kit, and cassettes. The vendor installs mod kits and reseals the Omega for its customer, the operator. NAFEC receives cassettes, processes data, furnishes printouts, and reports. No cost to either party is reflected. The operator will install the equipment, supply the loaded cassettes regularly, and remove and return the recorder and interface when it leaves the bank, or otherwise dispose of things as agreed by the FAA.

Comment (Huhn) The recorder box only needs to meet the specs to which it was designed, as long as it performs its intended functions without interfering with flight and landing of aircraft, there is no problem.

Manufacturers should send letters to FAA offices from which TSO is obtained. Notify that the mod kit, a minor modification, had been made to the Omega set, and that it did not change the TSO status of the modified box.

Depending on the Region's position on the modification, Region may send a letter of acknowledgment, may just file the notice, or may make inquiries but the exchange should be a routine matter. Vendors must make sure they have on file a letter notifying FAA that the minor mod has been made to the TSO.

You should study aspect of open, shorts, shorts to power/isolation in event of malfunction in recorder or its supply. Isolation of the recorder from the Omega is important to approval...should suffice.

Comment (Carmel) It would help if there were a sticker on the face of the recorder showing it is NAFEC property and that it was designed to NAFEC/FAA specifications.

Comment (Unidentified) Don't put the recorder on the same power-line bus as the Omega. It would be better to have the recorder continue to record so a discontinuance of the Omega would not be classified erroneously as a failure of the recorder in your reliability data.

Comment (Carmel) I recommend a data column for atmospheric noise and lightning strike counts. Participation by Omega users will be encouraged by ability to get a printout when it is called for. I strongly encourage taking all the available data on the cassette even if some is thrown out during processing on the ground. When the operator couples Omega to the autopilot, cross-track errors will become very important.

Concluding Remarks

Your presence has been a very substantial consideration, your attention during the 2-day conference, your travel time and investment. We at NAFEC feel obliged to carry off the program in the best way possible. Those with interest in participation please send a letter in response to this con-

ference. Reply will be through appropriate channels. FAA elements have been most helpful. Correspondence would be most welcome. Please express any interest of your airline or business when you contact Omega vendors; that should encourage the flow of information. We will get out proceedings as soon as possible. Many thanks for your helpful participation.

PROPERTY OF U.S. GOVERNMENT—RETURN TO—  
OMEGA DATA BANK, ANA-330 F.A.A.,N.A.F.E.C.  
ATLANTIC CITY 08405

SIDE B  
DO NOT  
RECORD  
THIS SIDE

DATE INSTALLED	DATE MAILED	AIRCRAFT No.
DATE REMOVED	FROM	OMEGA TYPE

79-165-25

FIGURE 25. CASSETTE DATA IDENTITY LABEL



**FIGURE 26. BUSINESS SESSION, WORLD-WIDE OMEGA DATA BANK CONFERENCE, MR. JOSEPH J. SCAVULLO, CHAIRMAN**

*APPENDIX A*

*SYNOPSIS OF DR. RZONCA'S DATA PRESENTATION*

A set of parameters, which characterize the operation of the airborne Omega navigator in the Omega signal propagation environment, is defined. The parameters include lateral deviations measured by the Omega navigator (assumed due to sudden phase anomalies), dips in the signal to noise ratio, occurrence of dead-reckoning mode operation, and synchronization loss. These parameters are expressed as percentages so that values from different Omega units and/or from different geographic locations may be combined.

A Mercator projection map of the world is divided in 10° latitude by 10° longitude cells. To identify any Omega coverage problems, data is combined from all units whose flight paths traverse a given cell during one month. To identify particular units which might operate less efficiently, data is combined from all cells for a given unit. To observe effects on airborne navigators due to seasonal and diurnal variations in the Omega signal environment, data is combined from all cells each month and also sorted according to solar zenith angle.

Occurrences of lateral deviations greater than 6.3 nmi, as indicated by the Omega navigator, will be correlated with USCG ground monitor phase-anomaly events. Occurrences of dips larger than 20 dB in the signal to noise ratio will be correlated with increases in atmospheric radio noise and with Omega transmitter outages or power reductions.

Accuracies will be evaluated by using gateway radar fixes to produce

graphs of sequential sampling of lateral deviations from track for each unit.

After data has been collected for approximately 2 years to provide a sufficient data base, correlations of Omega navigator lateral deviations and/or signal-to-noise ratio dips with solar activity indicators (X-ray flux, proton flux, magnetic indices, mean sunspot number) will be made. In addition, a study will be made of the shapes of the probability distributions for lateral deviations under various operational conditions.

Outlined on pages A-2 through A-3 are proposed contents of reports from the Omega Data Bank to be distributed to participants. Pages A-3 through A-4 are definitions of parameters referred to in the proposed reports.

Tables A-1 and A-2 are questionnaires to be filled out by the conference attendees. The questionnaires, when completed, will provide feedback to NAFEC as to what type of information is required by participants in the data bank.

#### Individual Flight Reports to be Sent to Each Participant

I-1. Printout of parameters (PO, LD, SN, SD, DR, SY, XT) computed from all data points during flight.

I-2. If values of any of the parameters exceed 25 within any given cell, the following will be printed: cell no., parameter value, data, GMT, lat/long, value of each data point contributing to parameter.

I-3. Mean and standard deviation of LDO values and of CDI readings.

### Quarterly Reports

R-1. Omega system characteristics overall. Using combined data from all units and all cells, for each month, printout of the parameters PO, LD, SN (eight stations, three frequencies), SD, DR, SY, XT.

R-2. Unit characteristics. For each month, for each unit, combining data from all cells, printout of parameter values.

R-3. Unit and geographic characteristics. For each month, if data from a particular unit produces parameter values  $\geq 25$  within a given cell, printout of unit number, cell number, and parameter value.

R-4. Sequential Sampling of Lateral Deviations. The absolute value of LDR, cumulative over each flight with a particular unit, is plotted versus the number of data points, cumulative, for each unit; each quarter, a continuation of the graph for each unit will be presented.

R-5. Correlation of lateral deviations  $\geq 6.3$  nmi with ground monitor Omega-phase data. For each unit, for all points contributing to PO, printout of unit number, cell number, data, GMT, Z, LDO,  $\Delta\theta_1$ ,  $\Delta\theta_2$ , and print flag = 1 if PCA is underway.

R-6. Effect of PCA's on accuracy. For each unit, for LDR time-correlated with PCA event, graph of LDR versus  $\Delta\theta_1(M)$ ,  $\Delta\theta_2(M)$  where  $\Delta\theta_n(M)$  = largest change in  $\Delta\theta_n$  measured during flight at time of PCA.

R-7. Correlation of  $\Delta S/N$  with increased atmospheric radio noise. For each Omega station, for

10.2 kHz, for each unit, for all data points contributing to SD, printout of unit number, cell number, date, T3, Z,  $\Delta S/N$ , duration of  $\Delta S/N$ , NA, LC,  $\Delta LC$ .

R-8. Correlation of  $\Delta S/N$  with transmitter outages or power reductions. For each unit, for all data points contributing to SD, printout of unit number, cell number, date, T3, duration of  $\Delta S/N$ , GMT and duration of transmitter outage or reduction in power.

### Additional Information to be Included in Final Report

F-1. For each unit, for each gateway location, graph of Weibull distributions of RE for the following ranges of Z: (1)  $0^\circ \leq Z < 45^\circ$ , (2)  $45^\circ \leq Z < 90^\circ$ , (3)  $Z \geq 90^\circ$ .

F-2. For each unit, calculate mean LDO from all flights combined. Graph Weibull distributions of LDO using: (1) points with LDO > mean, (2) points with LDO < mean.

F-3. For each Omega station, for 10.2 kHz, for each unit, for all points contributing to SD, graph  $\Delta S/N$  versus  $\Delta LC$ ; for each lightning counter location used in obtaining LC values, plot NA and LCM versus month.

F-4. For each unit, from all cells combined, for points contributing to LD which are time-correlated to  $\Delta\theta$  caused by increased X-ray flux, graph maximum value of LDO occurring within  $\Delta\theta$  time period versus HR.

F-5. For each unit, for polar regions, for  $\Delta\theta$  associated with proton flux, graph maximum LDO occurring during  $\Delta\theta$  time period versus proton flux for:

(1) proton energy  $> 10$  Mev, (2) proton energy  $> 100$  Mev.

F-6. For each unit, for polar regions, for all points contributing to LD, graph LDO versus AE.

F-7. For each unit, for equatorial regions, for all points contributing to LD, graph LDO versus equatorial magnetic indices.

F-8. For each unit, for LDO and/or  $\Delta S/N$  correlated with local sharp increases in magnetic activity, graph LDO versus  $\Delta$  magnetic activity and  $\Delta S/N$  versus  $\Delta$  magnetic activity.

F-9. For  $LDO \geq 3$  nmi: To evaluate the usefulness of PROPHEET as a solar flare SPA and PCA event early warning system, calculate phase difference corrections for 10.2 kHz for each LOP affected by flare activity by using: (1) PROPHEET computer program, (2) current USCG Omega model computer program. Graph these two calculated phase corrections and the Omega navigator phase correction versus LDO.

F-10. For each unit, for values of  $LDO \geq 6.3$  nmi and  $Z \leq 45^\circ$ , from all cells combined, calculate mean value of these LDO each month = LZ. Graph: (1) LZ versus month, (2) mean sunspot number versus month.

#### Definitions

Unit - Particular combination of type of aircraft, Omega navigator, antenna, and location.

Identification Code - A four digit code assigned to each unit, each digit representing a generalized classification rather than a particular model or manufacturer (see Classifications).

Cell Number - Number assigned to a particular  $10^\circ$  latitude by  $10^\circ$  longitude region on a Mercator projection map of the world.

Standard LOP's - As a standard measure for comparison of data from various Omega navigators and from the USCG ground monitors, two LOP's are formed with respect to those three stations whose received S/N values are greatest in the Omega navigator. However, if the GDOP  $> 3$  nmi and/or the LOP crossing angle,  $\theta$ , satisfies the relation  $\theta < 30^\circ$  or  $\theta > 150^\circ$ , then the next lower S/N value is chosen for the third station and GDOP and  $\theta$  are checked.

$\theta_n$  - Change in 10.2 kHz phase difference for "standard LOPn" measured at nearest ground monitor.

S/N - Signal to noise ratio.

LDO - Lateral deviation from desired track as measured by Omega.

LDR - Lateral deviation from desired track as measured by ATC radar.

RE - Radial error = Omega position fix--ATC radar fix.

PO - Percent of data points with  $LDO \geq 6.3$  nmi.

LD - Percent of data points with  $LDO \geq 3$  nmi.

SN - Percent of data points with  $S/N < R(1/2)$ , where  $R(1/2)$  = one half the mean value of S/N measured during a given flight.

SD - Percent of data points for which S/N dipped by  $\geq 20$  dB.

DR - Percent of data points for which dead-reckoning mode was in operation.

SY - Percent of data points for which synchronization loss occurred (includes all data points until station synchronization is regained).

XT - Percent of data points for which Omega CDI reads  $\geq 3$  nmi.

Z - Solar zenith angle.

B, C - Constants used in the Weibull distribution.

AE - Auroral electrojet indices.

GDOP - Geometrical dilution of precision for stations used for navigation, using Omega lat/long for position; normalized to an ideal geometry 1-mile system.

HR - Hardness ratio = (flux of 0.5 to 3A° X-rays)/(flux of 1 to 8A° X-rays).

$\Delta S/N$  - Dip in signal to noise ratio.

T1 - GMT when  $\Delta S/N \geq 20$  dB begins.

T2 - GMT when  $\Delta S/N \geq 20$  dB ends.

T3 - GMT when maximum value of  $\Delta S/N \geq 20$  dB occurs.

LC - Lightning discharge count (5-minute or hourly) from National Weather Records Center (NWRC) use values of LC from counter nearest to aircraft location when data is recorded.

$\Delta LC$  - Change in LC which occurs during time that  $\Delta S/N \geq 20$  dB;  $\Delta LC = (1/2) [LC(T1) + LC(T2)] - LC(T3)$ ; if only hourly values are available for LC, divide by 12 to obtain estimated 5-minute value.

LCM - Sum of LC at given location in one month.

NA - Westinghouse Georesearch Lab (WGL) monthly atmospheric noise prediction for specified geographic location.

#### Classification Used in Identification Code

A. Aircraft are classified according to ATC aircraft approach categories:

1. Category A - Speed less than 91 knots; weight less than 30,001 pounds.

2. Category B - Speed 91 knots to 121 knots; weight 30,002 to 60,000 pounds.

3. Category C - Speed 121 knots to 141 knots; weight 60,001 to 15,000 pounds.

4. Category D - Speed 141 knots to 166 knots; weight 150,001 or more.

5. Category E - Speed 166 knots or more; any weight.

B. Omega navigators are classified as:

1. Single frequency
2. Composite
3. Difference frequency
4. Rho-Rho
5. Omega/VLF

C. Antennas are classified as:

1. H-field
2. E-field

D. Omega antenna locations on aircraft are classified as:

1. Bottom aft, in negative pressure area
2. Bottom forward

3. Top aft  
4. Top forward

5. Top, at or just aft of  
C.G. and close to electrical center

VALUE OF EACH OF THE REPORT TOPICS

1000: 1 = Very Useful  
5 = Of Limited Use  
2 = Of Interest, But Not Useful  
4 = Of No Interest

Assign one of the code numbers to each report topic below.

1-1	1-1
1-2	1-2
1-3	1-3
1-4	1-4
1-5	1-5
1-6	1-6
1-7	1-7
1-8	1-8
1-9	1-9
1-10	1-10
1-11	1-11
1-12	1-12

TABLE A-1. OMEGA TOPICS RATING CHART

VALUE OF EACH OF THE REPORT TOPICS

CODE: 1 = Very Useful  
2 = Of Limited Use  
3 = Of Interest, But Not Useful  
4 = Of No Interest

Assign one of the code numbers to each report topic below.

I-1. \_\_\_\_\_

F-1. \_\_\_\_\_

I-2. \_\_\_\_\_

F-2. \_\_\_\_\_

I-3. \_\_\_\_\_

F-3. \_\_\_\_\_

R-1. \_\_\_\_\_

F-4. \_\_\_\_\_

R-2. \_\_\_\_\_

F-5. \_\_\_\_\_

R-3. \_\_\_\_\_

F-6. \_\_\_\_\_

R-4. \_\_\_\_\_

F-7. \_\_\_\_\_

R-5. \_\_\_\_\_

F-8. \_\_\_\_\_

R-6. \_\_\_\_\_

F-9. \_\_\_\_\_

R-7. \_\_\_\_\_

F-10. \_\_\_\_\_

R-8. \_\_\_\_\_

TABLE A-2. AIRBORNE DATA FOR OMEGA DATA BANK

Check data that you expect to provide from your Omega navigator to the recorder interface

- \_\_\_\_\_ Date: Julian \_\_\_\_\_ or Calendar \_\_\_\_\_
- \_\_\_\_\_ Time of Day; GMT
- \_\_\_\_\_ True Airspeed: Knots
- \_\_\_\_\_ Magnetic Heading: Degrees
- \_\_\_\_\_ Waypoint From: Lat/Long
- \_\_\_\_\_ Waypoint To: Lat/Long
- \_\_\_\_\_ Time To Waypoint: Min/Sec
- \_\_\_\_\_ Desired Track Angle: Deg/Min
- \_\_\_\_\_ Omega Track Angle: Deg/Min
- \_\_\_\_\_ Omega Along Track Error: NM
- \_\_\_\_\_ Omega Cross Track Error: NM
- \_\_\_\_\_ Omega Drift Angle: Deg/Min
- \_\_\_\_\_ Omega Present Position: Lat/Long
- \_\_\_\_\_ Omega Signal-To-Noise Ratio: \_\_\_ All Frequencies: DB \_\_\_ All Stations: DB
- \_\_\_\_\_ Omega Stations Received/Deselected
- \_\_\_\_\_ Dead Reckoning Mode Indication
- \_\_\_\_\_ Omega Wind Direction: Deg/Min
- \_\_\_\_\_ Omega Wind Speed: Knots
- \_\_\_\_\_ Omega Ground Speed: Knots
- \_\_\_\_\_ Lines Of Position
- \_\_\_\_\_ Phase Corrections: CEC
- \_\_\_\_\_ Internal Status/Warning Signals
- \_\_\_\_\_ Reference Position (if Available)

**COMMENTS**

Check this table for errors in data from your DMC-2 navigation to the location.

**Use this page to make any comments on the proposed data presentation. Include any suggested changes to report topics or any additional information that would be useful to your organization.**

\_\_\_\_\_ Data: Julian \_\_\_\_\_

\_\_\_\_\_ Line of Day: 001 \_\_\_\_\_

\_\_\_\_\_ Line Assigned: 001 \_\_\_\_\_

\_\_\_\_\_ Magnetic Heading: 000 \_\_\_\_\_

\_\_\_\_\_ Magnetic True: 000 \_\_\_\_\_

\_\_\_\_\_ Magnetic Air: 000 \_\_\_\_\_

\_\_\_\_\_ Line in Magnetic: 000 \_\_\_\_\_

\_\_\_\_\_ Desired Track Angle: 000 \_\_\_\_\_

\_\_\_\_\_ Dead Track Angle: 000 \_\_\_\_\_

\_\_\_\_\_ Dead Along Track Error: 00 \_\_\_\_\_

\_\_\_\_\_ Dead Cross Track Error: 00 \_\_\_\_\_

\_\_\_\_\_ Dead Diff Angle: 00.00 \_\_\_\_\_

\_\_\_\_\_ Dead Track Position: 00.00 \_\_\_\_\_

\_\_\_\_\_ Dead Signal-to-Noise Ratio: 00.00 \_\_\_\_\_

\_\_\_\_\_ Dead Position: 00.00 \_\_\_\_\_

\_\_\_\_\_ Dead Heading: 00.00 \_\_\_\_\_

\_\_\_\_\_ Dead Line Direction: 00.00 \_\_\_\_\_

\_\_\_\_\_ Dead Wind Speed: 00.00 \_\_\_\_\_

\_\_\_\_\_ Dead Ground Speed: 00.00 \_\_\_\_\_

\_\_\_\_\_ Line BT Position: \_\_\_\_\_

\_\_\_\_\_ True Correction: 00.00 \_\_\_\_\_

\_\_\_\_\_ Internal Status/Warning Signals: \_\_\_\_\_

\_\_\_\_\_ Relative Position (if Available): \_\_\_\_\_

**APPENDIX B**

**QUESTIONS, RESPONSE, AND COMMENT FOLLOWING PRESENTATION**

**GIVEN BY ROBERT ERIKSON**

Question (Unidentified) What information is available through the "Propagation Status" information in the sample record you displayed earlier?

Response (Erikson) Stations are automatically deselected based upon the manufacturer's implementation reflecting its ideas as to operational problem areas due to projected propagation disturbances. The Omega stations selected for possible navigation are listed on the print-out. Subsequently, the received signal has to meet the signal-to-noise criteria. A bad station, already deselected, would not affect us.

Question (Unintelligible)

Response (Erikson) The recorder will operate automatically when the Omega set provides output. A particular manufacturer may arrange only to deliver data at the point when the aircraft takes off, thus the recorder would not use up tape excessively while on the ramp.

Question (Gibbs) On the final stage, do you intend to marry in the U.S. Coast Guard's status of the Omega stations?

Response (Erikson) What has been described here is only the recordings from an airborne Omega set. But, yes, there will be the ONSOD status merged into the program.

Question (Gibbs) The recorder will be rack mounted. Will it require any cooling?

Response (Erikson) I would turn that question over to Mr. John Pohlke of Base Ten Systems, Inc.

Question (Carmel) Are you formatted to look at two or more systems installed on the same aircraft?

Response (Erikson) Within the limits of space available for cards and capacity of the cassette, we can arrange to interface the recorder to more than one system.

Question (Carmel) Suppose two Bendix ONS-20 and one INS are on board, and you wish to examine the total navigation status of the equipment, will there be enough space?

Response (Erikson) We planned to make such an arrangement possible, but the specific design has to fit the space available.

Question (Carmel) Have you any provision for marking events of special interest?

Response (Erikson) The recorder has no special provision. However, if event making is possible through the Omega controls, the recorder may accept the mark. The ONS-20 allows us to flag an event (in some sets, pushing the hold button generates an asterisk, etc.)

Question (Carmel) I am looking for a single dedicated button to mark the time of an event to be correlated later with written notes.

Response (Erikson) The problem is that another switch added to the cockpit would entail more wiring. A separate board could be applied to generate a mark (not every one would do that). The connector to the outside world has 26 pins of which up to 9 per Omega will be needed for signals and 3 will be needed

for power to the recorder leaving several pins for such an installation.

Question (Carmel) Is there any tape status flag to note the event that tape has run out during flight, warning light, warning horn, etc.?

Response (Erikson) We have tried to keep the recorder automatic and simple. The warning light is on the face of the recorder. We have to live with some tape loss.

Question (Scavullo) Bob, could you answer differently in terms of selecting sampling rates? How about electing to record fewer readings per mile with more hours of recording?

Response (Erikson) A simple switch inside can change the frequency of sampling. If the rate is changed to once every 2 minutes, the aircraft may traverse more than one lane between samples, but flight time can be twice as long before the tape cassette is changed. (There is considerable flexibility in the recorder.) We are trying to standardize the records so as to avoid hardware changes at playback. Program changes are relatively simple.

Question (Kennedy) What can you say of the capacity of the tapes?

Response (Erikson) We are only recording on one side of the cassette. We selected a tape transport which needs the other track for precise control. We were willing to take out a cassette and replace it as the manpower was the same if we had merely reversed the cassette. The message capacity of that side is calculable from lengths of tape,

packing density, bits per sample, and interrecord gap. (With a 1,024-bit record length, the nominal 300-foot (282 feet) tape length would accommodate 1,660 samples.)

Question (Armstrong) If the recorder is connected to two Omegas and an INS, will there be a correlation problem in the absence of an INS clock?

Response (Erikson) Only position data are taken from an INS. The position data from the ONS is frozen in memory until the message is written. The difference in time should be only parts of seconds. But, all records will be on the same tape in the sequence as planned.

Question (Unidentified) Has the recorder been tested to be sure it does not induce a complete failure in the Omega?

Response (Erikson) We just received the first equipment 2 days ago. It has not yet been tested by us. The power line to the recorder is separate. The Omega manufacturers will help us protect the Omega sets. Canadian Marconi uses an optoisolator to provide some 3,000 volts isolation between output and input. Either can be shorted and the other not affected.

Question (Diederich) I am a bit disturbed about the arbitrary switch you've got to change data rates. Yesterday, Dr. Rzonca invited us to provide feedback. Just because the flight is longer, we should not change data rates. Surely data rates can be determined by the amount of information available or needed. Suppose we try to find out not only what the level of SNR is, but what SNR is adequate to navigate with and

what percentage of the time it is required to exceed a given level in order to support navigation? That is debatable. The question cannot be answered in one go. We will need to know what percentage of the time the required SNR is actually available.

Answer (Erikson) When I speak of format, I am considering the total number of bits to be processed in a message. Unless we standardize the block size, each manufacturer may decide on delivering a different number of bits and the playback hardware may have to be changed for every different Omega configuration. The selection of message increments of 512 bits was intended to save recording space on the tape. We will not always need to record a complete message. Writing all the bits up to the (512 or 1,024 etc.) block size selected may suffice; subsequent bits can be zeroed out. If every bit were to be captured, the switching requirements in the circuitry would be overwhelming. The recording rate will be selectable from a sample-message-per-minute to once-per-hour in convenient increments. Most Omega sets can support a rate of once per minute. Faster rates seem to be excessive and rates as slow as once in 15 minutes overlook too many miles of airspace. It appears that a data record rate should be between 1 per minute and 1 in 5 minutes.

Comment (Scavullo) Let us not confuse data rates, sampling rates, and other rates. Some Omega equipment updates every 10 seconds and could deliver all its information more often than one set per minute. We are here talking about the frequency of recording on tape, a complete message or set of all digital data available within an

Omega set relative to a particular point of time during the flight. The data stream may refresh buffer memory in the recorder continuously, but only at the designated sampling rates does the recorder freeze the memory after which memory is discharged onto the tape for a record tagged by time of day as frozen.

Question (Diederich) But sometimes there will not be information worth recording. To save space on the tape, could (the system) be organized to not record when the information does not warrant a record? (This would possibly increase the flight time per cassette and reduce the effort of post-flight processing.)

Response (Erikson) What sort of microprocessor or logic is available to detect abnormalities? The recording we now propose is straightforward and feasible. We do not know how to select only meaningful information for the record and reject all other. We must not add extensively, either to the Omega set, the recorder, cost, weight, or complexity. And we must not postpone the work much longer. Even if our sampling rate were to limit recording to 8 hours of flight, that would suffice for many oceanic routes. Thus, the worst case might require a change of cassette at both terminals. But, once the data has been recorded, we can cope with it in our facilities.

Manufacturers of Omega sets have made the 2,048 bit maximum seem very reasonable. The Dynell Mark VII equipment has furnished all its data in 900 bits per sample. The Litton ONS-201 equipment furnished all data, including propagation data and navigation data, in about 1,000 bits.

Question (Scavullo) Last evening, Mr. Diederich asked what benefit we might gain by recording along track, crosstrack, and other data of the navigation set. Would you answer that question at this time?

Response (Erikson) If there are no problems en route, the navigation data set may be abandoned. However, there will be no chance to question the flight crew about a particular event. The navigation data seems to us to be worth recording on tape as insurance that we may be able to resolve questions with it. Discrepancies in magnetic heading, as an example, may represent a faulty input or inadequacy of software--that would not want to be confused with signal coverage or propagation problems.

We talked about accuracy and what should be the reference standard. Without Omega signals at the receiver, there will be no such question. We, therefore, are concentrating on the availability of adequate and consistent navigation signals.

Comment (Carmel) I must agree. Any question we have had over the past several years has required that we know what happened prior to the event. It is essential that when signals have been degenerating over a period of time, the record show that and not simply the final dip below threshold.

Question (Unidentified) If you are going to record heading and true airspeed, why not record also altitude? Winds will be more important for flight planning if wind structure can be related to altitude. I understand we are talking about Omega winds. If you can supply the wind-altitude records,

you will do the Nation a lot of good.

Response (Scavullo) Omega sets do not contain altitude data. We don't know how to inject it. We only can look to flight plans or operational flight records at this time. Of course, flight plans change in flight. However, recording altitude is another piece of business. We have only one track in the recorder and have no way to add anything to it at present. First we must get the recorders onboard aircraft.

Comment (Unidentified) There are more uses for the navigation data set than for interpreting propagation measurements of signal coverage.

Response (Erikson) We said there were four card slots in the recorder. Enthusiasm could quickly make these slots insufficient. We could come to wish we had selected a 3/4 ATR long box and arrange also for space to add a side box. We must do our present job and the designs selected for the purpose will not support other jobs if add-ons are needed.

Question (Carmel) Does the recorder provide for a second data track? Can we use a dual head and provide for event recording?

Response (Erikson) The original recorder almost entirely filled a 3/4 ATR box. The tape deck involved a number of moving parts, including belts. Its estimated mean time between failure was about 5,000 operating hours. The later design does permit us space for four custom-boards and the smaller tape deck, about 1/3 smaller, has only two moving parts so mean time between failure is 15,000 operating hours.

The second track is already occupied with a tone signal for control of the mechanism.

Question (Unidentified) Does your spec request a fault analysis to assure the design is safe for air-borne operation?

Response (Scavullo) There are only two moving parts in the recorder. The power supply operates from a source of 110 VAC power from below 50 cycles to above 400 cycles per second. A thermostat is incorporated to shut off power when temperature of the unit is below a minimum level or above an upper limit--the on range is safe. There is not other special protection.

Question (Gibbs) Is the recorder going to be qualified as an FAA-approved item?

Response (Scavullo) At the end of our program, we will have a business session in which other FAA people may help me provide an answer to that question.

Question (Gibbs) It seems the data bank is more oriented to scientific than to navigation questions. Emphasis is being placed on raw data. If there are problems in navigation, the raw data should back up the inquiry. I believe that ONSOD and experimenters such as Dr. Reder are collecting all the scientific data via monitoring stations that will be needed. The emphasis should be placed on accuracy and reliability of navigation with just enough engineering data collected in the bank to help resolve questions around anomalous events.

Response (Scavullo) We are not charged with a scientific

investigation nor are we assessing navigation accuracy. Instead, we see this effort as an engineering investigation. The navigation data will be there for our use.

Response (Erikson) We will get Omega position, status words showing whether the set went into dead reckoning, whether an internal failure had been identified by the set so that tabulated results will give some measure of system reliability, percentage of time in dead reckoning, and how long were periods of dead reckoning.

Comment (Gibbs) I understand that the data bank would combine navigation inputs from over the world by many airlines in a central place and that this project would be to back up the airline and military navigation data. The information needed to back up a navigation event would be only such things as the stations being tracked, calculated bearing to the stations since geometry has an effect on navigation along with signal-to-noise ratio. Collection of raw Omega data appears to be a duplication of work being done at the monitor stations.

Response (Erikson) Monitoring stations and the ONSOD validation flights do provide scientific information. There are time and monetary constraints which limit the number of aircraft which can be equipped for scientific measurements and the number of probe flights they can make. The commercial flights will be able to secure engineering measurements (at low cost) with particular aircraft, particular Omega sets, and frequent sampling of noise/signal. This is the only approach giving us more than a go--no go observation; data are systematically

collected and processed for a normalization of the important effects. No individual manufacturer will be sure whether to seek relief from ONSOD, the installer, the user, or go back to the drawing board if it must do all its own data collection and analysis of an unfortunate navigation event.

Comment (Scavullo) We undertook this project to characterize the real operational Omega environment. The rationale is set forth in the paper given to you titled, "Probing the Airborne Omega Environment" reference B. In particular, we expect to explore that part of the environment which ONSOD could otherwise miss in the air spaces between the rather widely separated monitors on the ground. We want more in-flight information about the presence of Omega signals along real operational routes, under normal operational conditions, from enough aircraft to get the answers to questions which ONSOD cannot supply.

Operators have had to place a person in the cockpit to collect those records which already have been accumulated. We could not hope to impose on the air carriers to secure much more information by adding workload or increasing the crew of 16 or adding more aircraft. The data collected during Omega flights of commercial aircraft has, up to now, been recorded by hand in only one or two aircraft of an entire commercial fleet. Sampling of routes during flights around the world has taken place perhaps once or twice a year, and that data has stressed overall accuracy of navigational performance.

Endpoint accuracies and arrivals over fixes near transoceanic

destinations has accumulated to a rapidly increasing confidence in the Omega navigation system. We can in fact secure useable navigation data frequently from the start to the end of a route. After satisfying our primary concern with Omega propagation, we may switch the emphasis. It will likely take 1 or 2 years to generate the probability distributions that characterize Omega propagation around the world.

Question (Gibbs) (indistinct-- apparently: "Why cannot a report be based on less information, navigation-oriented data written down by hand?")

Response (Scavullo) NAFEC would only be willing to publish an official technical report based on data we have obtained. However, I cannot visualize a NAFEC report unless the technical information has been collected from in-flight Omega sets under our supervision.

Comment (Carmel) The equipment onboard must collect all the data that is available. The user may then extract portions of interest from the printout. Each user will have different needs. We cannot limit the equipment now to meeting the requirements of one user and ignore data that another user would want. It seems to me that the data you are proposing to record is complete and is (about) the minimum required.

Comment (O'Brien) I think the data you will collect will be invaluable. When Australia comes on the air, we would like to see how it fills the present holes in coverage and make comparisons of the system performance before or after. I'd hate to see any of the navigation data left out.

Remarks (Scavullo) Let me hold up one of the cassettes. They are commercially available for a little more than \$8. The decal bears the statement "Property of U.S. Government, return to Omega Data Bank, ANA-330, FAA/NAFEC, Atlantic City, NJ, 08405, USA." That address will be correct on the outside of an envelope or mailing container. Six information blocks include: Data

installed, date removed, date mailed, origin, aircraft tail No., Omega type number. (See figure 25, page 95.)

#### REFERENCE

13. Scavullo, J. J., Probing The Airborne Omega Environment, NAFEC Letter Report No. NA-77-24-LR, May 1977.

*APPENDIX C*  
*TECHNICAL DETAILS*

Engineering Requirements for Kits to Modify Omega Navigation System  
with Output Interface for In-Flight Recording of Digital Data

Modification kits shall be designed, manufactured, and provided. Parts, materials, software, or installation hardware shall be included along with instructions for introducing the modification into the production model airborne Omega Navigation System specified.

The modification shall be designed so as not to prevent or preclude eventual restoration of the Omega equipment to its original functional configuration and performance characteristics. With the instructions accompanying each kit, the authorized field service facilities of the Omega equipment manufacturer shall be capable of introducing and removing all the modifications.

A properly installed modification kit shall result in the delivery of digitized technical data for recording in actual flight operations by means of digital-data tape recorder. Items of information to be included in the output data stream are listed below in two groups.

**Group 1. Signal-Propagation Data-Set**

Date: Julian or Calendar

Time of day: GMT

Present position: Lat/long

Quality of received signals: Stations received and status, stations deselected, warning signals, internal failure code and/or signal-to-noise ratios

**Group 2. Navigation Data-Set**

Waypoint from: Lat/long

Waypoint to: Lat/long

Distance-to-go: Nmi

Magnetic heading: Degrees or radians

True airspeed: Kts

Groundspeed: Kts

Desired track angle: Degrees or radians

Wind speed: Kts

Drift angle: Degrees or radians

Wind direction: Degrees or radians true

Cross track error: Degrees or radians

Cross track distance: Nmi

Lines of position

All available data are to be recordable in sets or messages in a cassette recorder. Rates of delivery of messages to the recorder need not be more frequent than once in a 30-second interval nor less frequently than once in a 120-second interval.

Since the primary objective is to survey the distribution and quality of Omega/VLF reception along world-wide routes of commercial interest, the data listed in Group 1 is essential. However, all the other propagation and navigation data are being sought because of their possible usefulness in analysis of data. Since the recorders will not be manned, nor will observers be on duty during the in-flight data collection, there will be no other source of information with which to evaluate unusual effects of solar activity or other propagation phenomena. The modification kit, as connected to a recorder, shall not adversely affect the operation of the Omega set in which it is installed.

The in-flight observation program is expected to continue for at least 1 year and may be extended to 2 years, depending on the results obtained during the first 6 to 12 months. Recorders will be available by July 1, 1978, and data collection is planned to begin between July 1 and October 1, 1978, in commercial aircraft already equipped with the production model Omega Navigation System to which this modification kit can be applied.

In order to be processed and recorded properly, output data delivered from the Omega sets must conform to specifications for either Configuration A or Configuration B as follows:

A. Preferred Configuration: No signal conditioning board required in cassette recorder.

Data and clock rates must be between 100Hz and 2400Hz with all signals compatible to CMOS logic levels 0 to 5V. The following three signal lines are required:

1. **Buffer Enable:** A signal line that controls the loading of data into the buffer and initiates recording of a data block on tape. When hi, data can be loaded into the buffer, and when it goes low, it writes data block on tape.

2. **Buffer Clock:** This line strobes whatever logic level is present on the data line into memory on the positive edge. The Buffer Clock must remain low 50 usec after Buffer Enable is brought high. The minimum high pulse width is 100 usec.

3. **Buffer Data:** This is the data input line. All data must be valid during the time that the Buffer Clock is high.

**B. Acceptable Configuration: Signal conditioning boards required in cassette recorder.**

**1. Required signals on output lines.**

a. **Sync.** Goes high to designate the beginning of a new data block; may be transmitted on data line.

b. **Data line.** Bit serial, character serial data is presented on this line.

c. **Clock line.** If data is not self-locking, this line must contain a clock to decode data.

**2. Data rate.**

The data shall be provided at a rate which can be buffered down for recording at between 100 and 2400 bits per second, but need not be continuous.

**3. Data**

The data transmitted from the Omega sets need not be 32 bit word with 8 bit of address, but must output the data in a logical repeatable sequence for each data block.

**4. Acceptable Data Codes**

- a. Non-return to zero with separate clock
- b. Return to zero
- c. Phase encoded
- d. Frequency shift keyed

**PROPOSAL FOR A  
DIGITAL DATA RECORDING  
MODIFICATION KIT  
FOR THE CMA-740 ONS**

**VOLUME 1: TECHNICAL PROPOSAL**

**Submitted to  
FEDERAL AVIATION ADMINISTRATION**

Prepared by:

J.C. Laroche

Approved by:

Laroche

**CMC Proposal No. P-1549  
June 9, 1978  
Revision 2, December 11, 1978  
0542A/79A**

**CANADIAN MARCONI COMPANY  
AVIONICS DIVISION  
2442 TRENTON AVENUE  
MONTREAL, QUEBEC, CANADA  
H3P 1Y9**

**FOREWORD**

This proposal is submitted by Canadian Marconi Company in response to FAA Request for Proposal RFP NAOO-8-51.

The present Volume, Volume I of the proposal, describes the engineering approach and the technical characteristics of the required modification kit, and its implementation.

Volume II contains a detailed description of the data format.

LIST OF REVISED PAGES

Page	Revision No.	Date	Revision	Remarks
2	1	24/07/78	Para. 2.1	Content of frame modified to increase recording time from 4 hours to 13 hours
3	1	24/07/78	Fig. 1	
4	1	24/07/78	Para. 2.4	
5	1	24/07/78	Para. 3.3	
13	1	24/07/78	Para. 7.2	
14 & 15	1	24/07/78	Table III	
2	2	11/12/78	Para. 2.1	Content of frame modified to limit size to 2048 bits
5	2	11/12/78	Para. 3.2 Para. 3.3	
13	2	11/12/78	Para. 7.2	
14 & 15	2	11/12/78	Table III	
15A, 15B, 15C	2	11/12/78	New Pages Added	

## TABLE OF CONTENTS

<u>SECTION</u>	<u>TITLE</u>	<u>PAGE</u>
1.0	INTRODUCTION	1
2.0	FUNCTIONAL DESCRIPTION	2
2.1	Software Driver	2
2.2	Sending Circuit	2
2.3	Interface Unit	2
2.4	Recorder Unit	4
3.0	INTERFACE REQUIREMENTS	5
3.1	Line Receivers	5
3.2	Timing Constraint	5
3.3	Recorder and Interface Unit Requirements	5
4.0	MECHANICAL SPECIFICATION	7
5.0	ELECTRICAL SPECIFICATION	8
6.0	DATA BURST CODING SPECIFICATION	10
6.1	Data Burst Timing	10
6.2	Data Burst Content	10
6.3	Interface Bits Content	11
7.0	FRAME CODING SPECIFICATION	13
7.1	Frame Structure	13
7.2	Frame Timing	13
7.3	Frame Coding	13
8.0	IMPLEMENTATION	17
9.0	CONFIGURATION CONTROL	18
10.0	OPERATION	19
11.0	MAINTENANCE	20

1.0 INTRODUCTION

The modification kit once properly installed in the RPU (Receiver Processor Unit) of a standard CMA-740 ONS, P/N 473-156, results in the delivery on the CDU (Control-Display Unit) data bus of the ONS of digitized technical data suitable for recording in actual flight operations.

The modification kit is designed so that there is no interference with the other functions of the ONS.

The kit can be installed and removed by authorized field service facilities of CMC, and the ONS can be restored to its original configuration and performance characteristics.

The present document provides all the relevant information for the user to be able to build the Interface Unit, to plan the installation, and to process the data recordings.

Revision 2

## 2.0 FUNCTIONAL DESCRIPTION

This chapter gives a simplified overview of the various functions performed to ultimately get the data on a magnetic tape cartridge, and their relationship (Figure 1).

### 2.1 Software Driver

After the ONS has completed a position fix, a specialized subroutine picks up the appropriate data from the internal storage of the RPU and processes it to make a single data frame.

- Data words are processed and packed in bytes (8 bits elementary segments); 252 bytes are to be prepared for each data frame.
- The frame is cut in by blocks of 6 bytes.
- Each block is presented to the sending circuit of the ONS Most Significant Byte First, typically every 50ms, along with the suitable control bits.

The software driver resumes execution every 30 seconds.

### 2.2 Sending Circuit

The sending circuit transfers the incoming blocks to the CDU (Control Display Unit) on the wires of the CDU bus, Most Significant Byte First.

Two sets of wires are utilized:

- clock lines
- data lines

The clock rate is nominally 16.6KHz; data is sent serially in an NRZ format as 8ms bursts.

Blocks are limited to 6 bytes because of hardware constraint in the sending circuit.

### 2.3 Interface Unit

This unit is provided by the user. The Interface Unit is hooked up in parallel with the input data wires and clock wires to the CDU.

The interface recognizes the relevant blocks of bytes by a kind of addressing scheme, so that there is no interference between the recording capability and the other devices which share the CDU bus.

The succeeding blocks are collated together in a temporary storage, until all of them have been received.

Revision 2

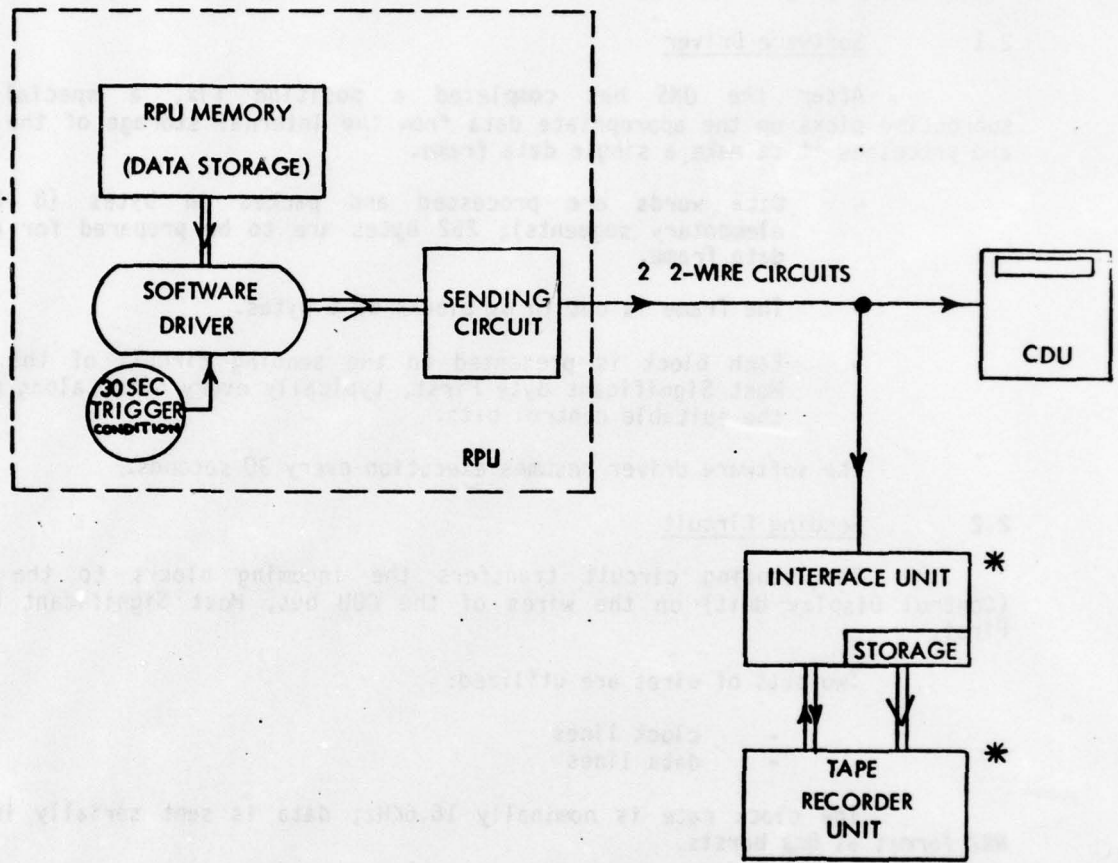

\* THOSE ITEMS ARE PROVIDED BY THE USER

FIGURE 1. FUNCTIONAL BLOCK DIAGRAM

Revision 2

Once the entire data frame has been reconstructed, the interface circuit activates the recorder and dumps the whole frame, bit by bit, to the recorder.

The handshaking procedure and the data transfer are controlled by the interface.

#### 2.4 Recorder Unit

This unit is provided by the user. The Recorder Unit accepts the data and control signals from the Interface Unit and writes the data onto a magnetic cartridge.

A typical recorder unit for this application is the Model 250 from MFE.

### 3.0 INTERFACE REQUIREMENTS

#### 3.1 Line Receivers

The data and clock lines are driven by DM8830 differential drivers, see Figure 2 (refer to 5.1).

The CDU itself utilizes optical couplers as per Figure 3.

In order to operate reliably and not to disturb the RPU and CDU, the line receivers used by the Interface Unit shall meet the following requirements:

- a) Load resistance shall be 1k or more between Hi/Lo lines.
- b) Binary decision thresholds shall be chosen for reliable operation, over the desired temperature range, with the line driven by the line-driver (Figure 2) and loaded by one line-receiver (Figure 3).
- c) The design shall provide noise-immunity to spikes consistent with the desired installation layout.
- d) The cables between RPU and Interface Unit shall be twisted-shielded pairs, the shield shall be grounded at both ends.

#### 3.2 Timing Constraints

- a) The Interface Unit shall be able to perform properly when the delay between 2 succeeding data frames is down to 1 second (see 7.2).
- b) The Interface Unit shall be able to perform properly when the delay between 2 succeeding data bursts is down to 10ms (see 6.1).

#### 3.3 Recorder and Interface Unit Requirements

- a) The Recorder and Interface Units shall be able to accept every 30 seconds a data frame of 252 bytes from the CMA-740.
- b) The Recorder and Interface Unit shall cope with a 1 second delay minimum between 2 frames.

This constraint implies that the Digital Recorder shall operate at 2400 Bauds minimum.

- c) For a typical Recorder Unit such as the MFE Model 150, the data density will provide at least 12 hours of recording time with a 450 feet PHILLIPS cassette.

Revision 2

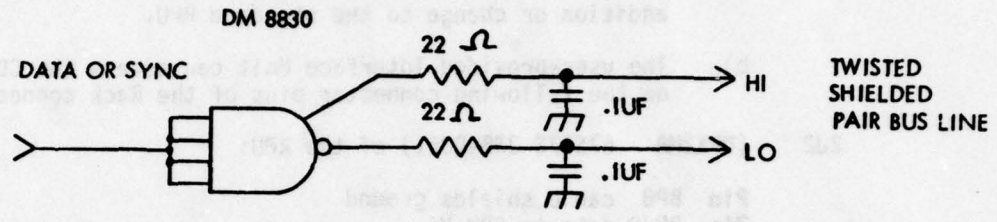

FIGURE 2  
TYPICAL LINE DRIVER

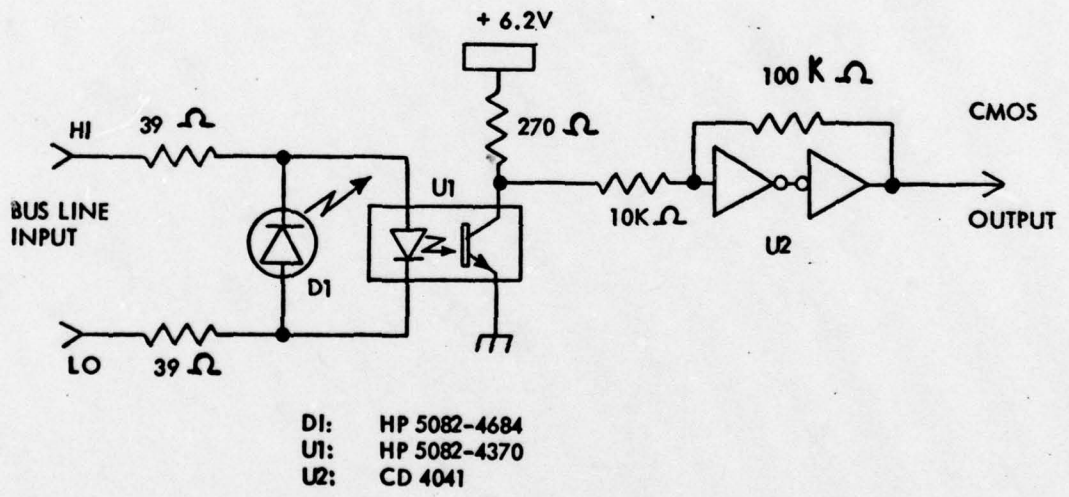

FIGURE 3. TYPICAL LINE RECEIVER

4.0

MECHANICAL SPECIFICATION

Mechanical Specification of Digital Data Source

- a) All the changes required to implement the modification kit are internal to the CMA-740 RPU; there is no mechanical addition or change to the standard RPU.
- b) The user-provided Interface Unit can access the CDU data bus on the following connector pins of the Rack connectors plug,

2J2 (DPX2MA - 67S67S-338-0061) of the RPU:

- Pin BP8 cable shields ground
- Pin BP39 data to CDU Hi
- Pin BP40 data to CDU Lo

- Pin BP49 sync to CDU Hi
- Pin BP50 sync to CDU Lo

2J2 is the bottom plug.

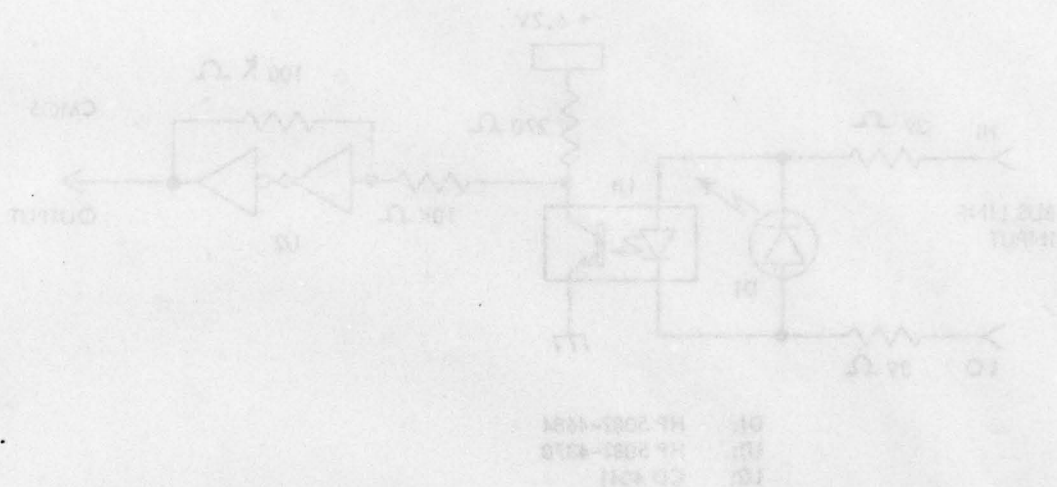

FIGURE 2. TYPICAL LINE RECEIVER

5.0 ELECTRICAL SPECIFICATION OF DIGITAL DATA SOURCE

The line drivers of the CDU lines are DM8830, as per Figure 2.

The CDU lines are terminated in the CDU by optical couplers, as per Figure 3.

The voltages and rise times on the bus line are specified by Figure 4 for both "Data" output and "Sync" lines.

Note that "Hi" and "Lo" lines are complement of each other.

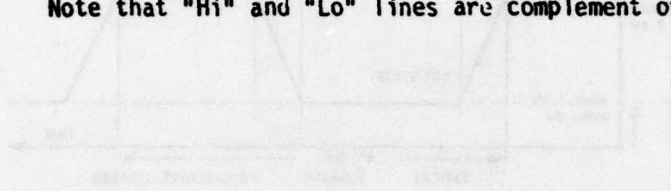

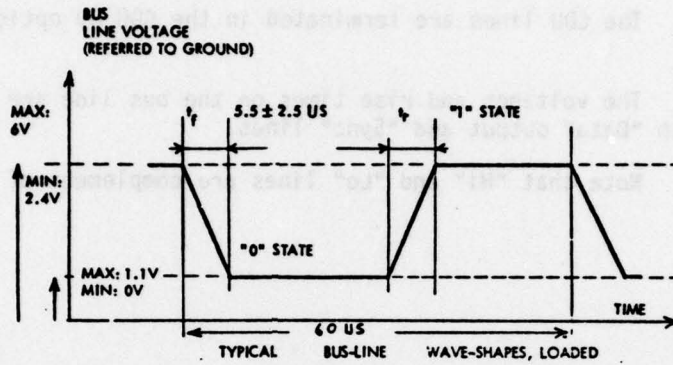

FIGURE 4. TYPICAL BUS LINE WAVE SHAPES, LOADED

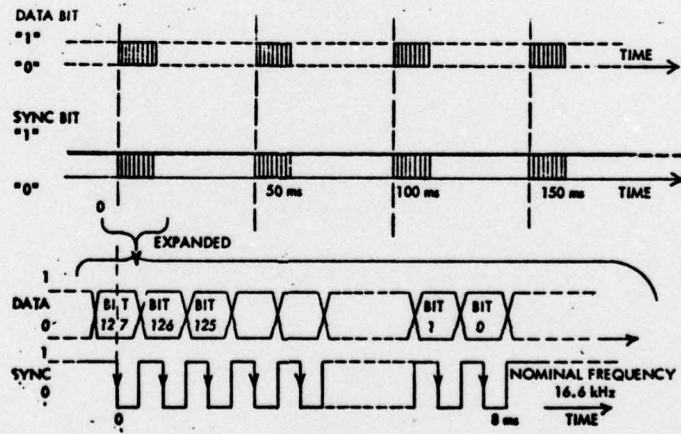

FIGURE 5. DATA BURST TIMING

## 6.0 DATA BURST CODING SPECIFICATION

This paragraph specifies the content and timing parameters of the data bursts available on the output data bus to the CDU.

### 6.1 Data Burst Timing (Figure 5)

The data bursts occurs at  $50\text{ms} \pm 40\text{ms}$  intervals.

- a) The "data" lines utilize an NRZ coding: a positive (negative) voltage difference between Hi/Lo lines correspond to a "1" ("0") data bit.
- b) The "sync" lines carry a gated square wave clock signal with a period of  $60\mu\text{s} \pm 10\%$  (16.6KHz): a positive (negative) voltage difference between Hi/Lo lines correspond to a "1" ("0") clock bit. The clock bit stays at "1" after the end of the data burst.
- c) The data burst is made of 128 consecutive data bits, labelled 127 to 0, received in this order (Most Significant Bit First). Each data bit changes at the 0/1 transition of the clock bit. Each data bit shall be strobed by the Interface Unit at the 1/0 transition of the clock bit.

### 6.2 Data Burst Content (Figure 6)

The 128 data bits of the data burst are made up of:

- a) CDU bits - bits 127 to 54. Those 74 bits are used by the CDU itself.
- b) Address bits - bits 53 and 52. Those 2 bits define the address of the device to which the remaining 52 bits are destined, according to Table 1.
- c) Interface bits - bits 51 to 0. Those 52 bits, when addressed to the Interface Unit, provide the suitable control and data bits to reconstruct a whole data frame.

TABLE 1

ADDRESS BITS		SELECTED DEVICE
#53	#52	
0	0	Interface Unit (Recorder)
0	1	Cabin Display
1	0	HSI Output
1	1	Reserved

NOTE: Address bits are received in the order: ----#53 #52----

6.3 Interface Bits Content (Figure 7)

The content of bits 51 to 0 of the data burst, when the mode bits 53 and 52 address the Interface Unit (see Table 1), is coded as a 4 bits control character and 6 data bytes.

a) Control Character

The 4 bits-long control character is made of bits 51 to 48. The Table II indicates their respective usage. When bit 51 is 0, the Interface Unit shall ignore the content of this data burst, bit 50 to 0.

TABLE II

CONTROL BIT	USAGE
#48	Always set to 0
#49	1 = First 6 bytes of new frame
#50	1 = Last 6 bytes of present frame
#51	1 = 6 bytes available 0 = ignore this data burst

NOTE: Control bits are received in the order: ----#51 #50 #49 #48----

b) Data Bytes

The 6 bytes following the control character are made of data bits 47 to 0. The bytes are numbered #5 to #0 and are received Most Significant Bit First, Most Significant Bit First. Bits within a byte are numbered 7 to 0.

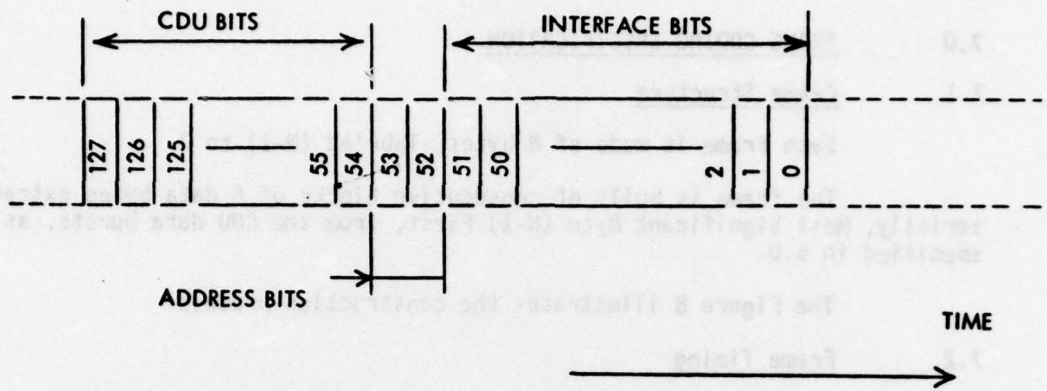

FIGURE 6. DATA BURST CONTENT (MSB FIRST)

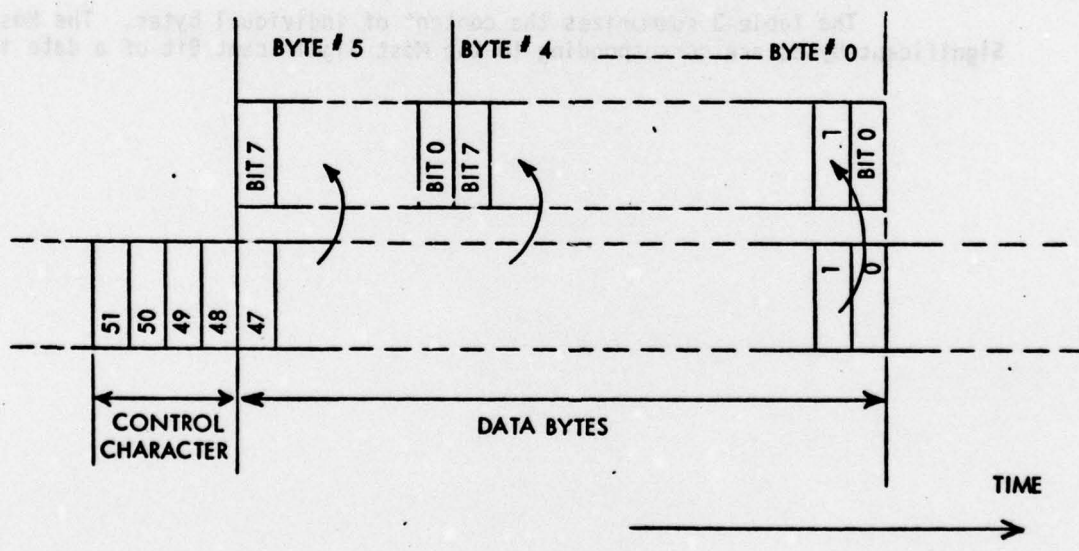

FIGURE 7. INTERFACE BITS CONTENT

## 7.0 FRAME CODING SPECIFICATION

### 7.1 Frame Structure

Each frame is made of N bytes, labeled (N-1) to 0.

The frame is built of consecutive blocks of 6 data bytes extracted serially, Most Significant Byte (N-1) First, from the CDU data bursts, as specified in 6.0.

The Figure 8 illustrates the construction process.

### 7.2 Frame Timing

- a) A minimum delay of 1 second is provided between the end of one frame and the beginning of the next one, so that the Interface Unit has time to dump frames onto the Recorder Unit.

This delay is measured between the time of occurrence of control bit 50 being set and control bit 49 being set later.

- b) Frames occur every 30 seconds.

### 7.3 Frame Coding

The Table 3 summarizes the content of individual bytes. The Most Significant Bytes are corresponding to the Most Significant Bit of a data item.

TABLE III

ITEM	LENGTH (BYTES)	NO.	DATA	TYPE (1 INCREMENT=)	UNITS	RANGE
GMT	2	0,1	Tens of Seconds (0 - 24 HR)	I	10 SEC.	0 TO 8639
DATE	3	2	DAY	I	1 day	0 TO 31
		3	MONTH	I	1 month	0 TO 12
		4	YEAR	I	1 year	0 TO 99
FROM	2	5,6 7,8	WAYPOINT "FROM"			+ 90 DG LAT, + 180 DG LONG
			LATITUDE (+North)	I	90 DG /32768	-32768 TO
			LONGITUDE (+East)	I	180 DG /32768	+32767
TO	2	9,10 11,12	WAYPOINT "TO"			+ 90 DG LAT, + 180 DG LONG
			LATITUDE (+NORTH)	I	90 DG /32768	-32768 TO
			LONGITUDE (+East)	I	180 DG /32768	+32767
DIST	2	13,14	DISTANCE TO GO	I	INM	-32768 TO +32767 NM
XTK	1	15	CROSS-TRACK ERROR	I	1/10 NM	-12.8 TO +12.7 NM
TKE	1	16	TRACK ERROR	I	$\frac{360}{256}$ DG	-180 TO +180 DG
OFFSET	1	17	HEADING OFFSET = TRUE HDG-MAG HDG	I	$\frac{360}{256}$ DG	-180 TO +180 DG
GS	1	18	GROUND-SPEED	I (NOT SIGNED)	3 KNOTS	0 TO 765 KT
WIND	1	19	WIND VECTOR WIND ANGLE	I	$\frac{360}{256}$ DG	-180 TO +180 DG
	1	20	WIND SPEED	I (NOT SIGNED)	3 KNOTS	0 TO 765 KT
TRK	1	21	TRUE TRACK	I	$\frac{360}{256}$ DG	-180 TO +180 DG
DRIFT	1	22	DRIFT ANGLE	I	$\frac{360}{256}$ DG	-180 TO +180 DG

Revision 2

TABLE III (CONT'D)

ITEM	LENGTH (BYTES)	NO.	DATA	TYPE (1 INCREMENT=)	UNITS	RANGE
CHOIC	2	23,24	MANUAL STATION SELECTION	CODED		
FRSW	1	25	MANUAL FREQUENCY SELECTION	CODED		
TXLOG	2	26,27	STATIONS USED	CODED		
QUALITY	1	28	QUALITY OF FIX	I	1/10 NM	0 TO 12.7NM
ERROR	1	29	GUESS OF ACCURACY	I	1/10 NM	0 TO 12.7NM
DIURNAL	24	30-53	24 PROPAGATION CORRECTIONS	I	2 CEC	-256 TO +255 CEC

Revision 2

(DATA FROM 1ST OMEGA SEQUENCE)

ITEM	LENGTH (BYTES)	NO.	DATA	TYPE (1 INCREMENT=)	UNITS	RANGE
POSITION	4	54-57	LATITUDE (+=NORTH)	F.P.	1 RD	-PI/2 TO+ PI/2
	4	58-61	LONGITUDE (+=EAST)	F.P.	1 RD	-PI TO +PI
BYTE	1	62	SYSTEM FAILURES	CODED		
WARN	1	63	SYSTEM WARNINGS	CODED		
MHDG	1	64	MAG HDG INPUT	I	$\frac{360}{256}$ DG	-180 TO +180 DG
TAS	1	65	TAS SYNCHRO INPUT	I (NOT SIGNED)	3 KT	0 TO 765KT
MODE	1	66	FLAGS "VLF" OR "OMEGA" MODE	CODED		
SNR	24	67-90	24 SNR MEASURES	I	RELATIVE SCALE	0 TO 101
NOTE: CMC-RESERVED DATA BEGINS HERE						
PHASES	24	91-114	24 PHASES	I	1 CEC	0 TO 99
PAD 1	5	115-119	PAD FOR 6-BYTES SUB-FRAME #20	NOT USED		

TABLE III (CONT'D)

Revision 2

(DATA FROM 2ND OMEGA SEQUENCE)

ITEM	LENGTH (BYTES)	NO.	DATA	TYPE (1 INCREMENT=)	UNITS	RANGE
POSITION	4	120-123	LATITUDE (+=NORTH)	F.P.	1 RD	-PI/2 TO+ PI/2
	4	124-127	LONGITUDE (+=EAST)	F.P.	1 RD	-PI TO +PI
BYTE	1	128	SYSTEM FAILURES	CODED		
WARN	1	129	SYSTEM WARNINGS	CODED		
MHDG	1	130	MAG HDG INPUT	I	360 DG 256	-180 TO +180DG
TAS	1	131	TAS SYNCHRO INPUT (NOT SIGNED)	I	3 KT	0 TO 765KT
DE	1	132	FLAGS "VLF" OR "OMEGA" MODE	CODED		
SNR	24	133-156	24 SNR MEASURES	I SCALE	RELATIVE 0 TO 101	
PHASES	24	157-180	24 PHASES	I	1 CEC	0 TO 99
PAD 2	5	181-185	PAD FOR 6-BYTES SUB-FRAME #31	NOT USED		

TABLE (CONT'D)

Revision 2

(DATA FROM 3RD OMEGA SEQUENCE)

ITEM	LENGTH (BYTES)	NO.	DATA	TYPE (1 INCREMENT=)	UNITS	RANGE
POSITION	4	186-189	LATITUDE (+=NORTH)	F.P.	1 RD	-PI/2 TO+ PI/2
	4	190-193	LONGITUDE (+=EAST)	F.P.	1 RD	-PI TO +PI
BYTE	1	194	SYSTEM FAILURES	CODED		
WARN	1	195	SYSTEM WARNINGS	CODED		
MHDG	1	196	MAG HDG INPUT	I	360 DG 256	-180 TO +180DG
TAS	1	197	TAS SYNCHRO INPUT	I (NOT SIGNED)	3 KT	0 TO 765KT
DE	1	198	FLAGS "VLF" OR "OMEGA" MODE	CODED		
SNR	24	199-222	24 SNR MEASURES	I	RELATIVE SCALE	0 TO 101
PHASES	24	223-246	24 PHASES	I	1 CEC	0 TO 99
PAD 3	5	247-251	PAD FOR 6-BYTES SUB-FRAME #42	NOT USED		
DUMMY 1	1	252	BYTES WHICH CANNOT BE FILLED UP			
DUMMY 2	1	253	BY THE CMA-740			
DUMMY 3	1	254	(CAN BE USED BY INTERFACE			
DUMMY 4	1	255	HARDWARE FOR STATUS REPORT)			

END OF FRAME

FRAME CODING

TABLE III

Revision 2

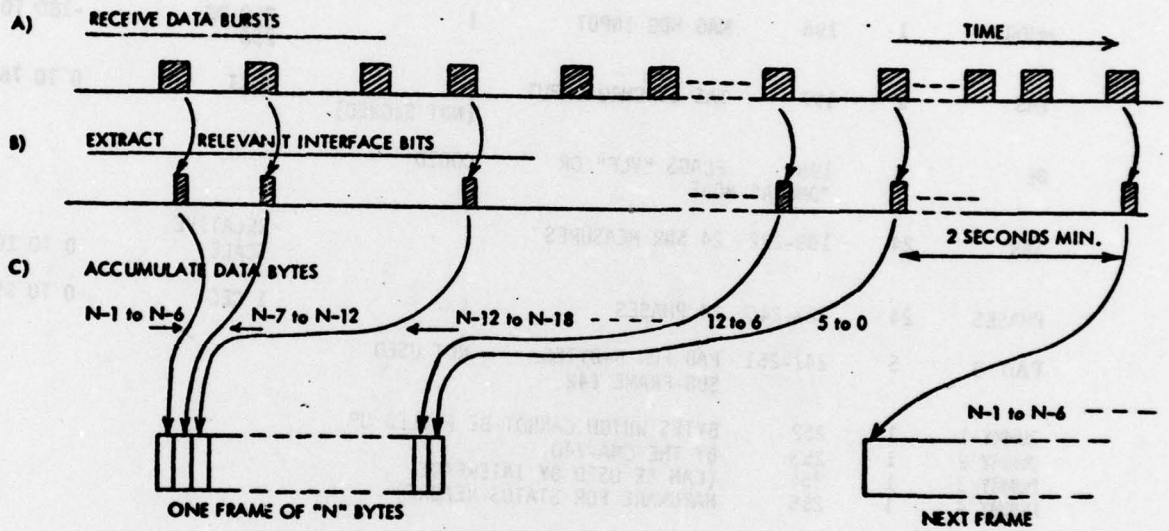

FIGURE 8. FRAME CONSTRUCTION

## 8.0 IMPLEMENTATION

There is no electrical or mechanical alteration to be made to the RPU. The modification consists of a system software change.

This operation requires the RPU to be opened, and the memory board to be exchanged with the factory programmed memory board contained in the modification kit. A system acceptance test is performed following this modification. This work can be carried out by a CMC authorized service facility.

The original program can be restored the same way.

**9.0**      **CONFIGURATION CONTROL**

The modification of a RPU for recorder data output will necessitate special configuration control actions. The best approach is to be determined with each operator of such modified equipment.

10.0 OPERATION

The operation of the modification kit is automatic and completely transparent to the operator of the ONS.

11.0

MAINTENANCE

- a) All the original test and maintenance procedures are valid without modification.
- b) The existing monitoring or BITE functions of the ONS provide suitable means of insuring the integrity of the operation of the modification kit:
  - The existing memory checksum self-test checks the software driver is operative.
  - The CDU self-test and watch-dog functions verify the data link does operate.

## Engineering Requirements for an Airborne Digital-Data Interface and Recording Set

### Introduction

This document contains the engineering requirements for a small semi-automatic airborne data-recording set. The set will incorporate provisions for custom interfacing to receive and record digital data available as outputs from various models of Omega navigation equipment selected for test during normal flight operations along world-wide air routes. When installed by commercial, business, or government operators in transport aircraft equipped with Omega avionics, the interface and recording set will normally operate unattended from the time an aircraft leaves a selected maintenance facility until it returns, after as many as 24 hours of long distance travel, to the same facility. The insertion and removal of a tape cassette, and the turning on and off of the recorder, will be accomplished by the carrier. All data input to the set will be digital in either serial or parallel arrangements.

### General Description

This engineering requirement covers airborne equipment whose purpose is to receive digitized data, representing internal functions of operational avionics equipment, and to record such data for post-flight processing. The immediate application of the required interface-recording set is for recording data derived in digital form from the Omega navigation system in a limited number of business, commercial, and government aircraft. Therefore, the set must be designed so that approval may be obtained to install it either in the flight deck or in the electronics rack of such aircraft. Particular aircraft are to be selected for the likelihood that their use will maximize sampling of Omega propagation and system performance over world-wide air routes during a period of at least 2 years. While installed and connected to take data, this set must not have any effect on operation of any other equipment also installed in the aircraft.

The interface-recording set is to be compatible with the in-flight environment, including pressure, temperature, shock, vibration, and available primary power, as reflected in specifications covered in ARINC Characteristic 580 for the Mark I Omega Navigation System. Specification 404A, "Air Transport Equipment Cases and Racking," also cited in those characteristics, describes the standard ATR racking system of packaging avionics for installation in commercial aircraft. Both these specifications were promulgated by Aeronautical Radio, Incorporated, 2551 Riva Road, Annapolis, Maryland, 21401.

### Functional Components and Documentation

The airborne interface and recording set will incorporate the following principal components within one of the standard ATR cases: a digital cassette-recorder deck; a card cage for electronic circuit cards; control circuitry; a data rate buffer, or memory, card; a power supply; and a multi-pin connector. A supply of twenty (20) compatible tape cassettes will be furnished with each set. A set of documentation also will be delivered with each set to cover installation, operation, maintenance, internal circuitry, and interfacing provisions.

The adaptation of this set to various data formats will be accomplished by adding custom interface cards in the Omega receiver processor unit, in the interface-recorder set, or in both. As many as six different models of airborne Omega navigation systems are already commercially available. It may be necessary to interface any of these models with the basic recorder set, in one aircraft or another, from time to time. In most cases, custom data-output cards will have to be added by its manufacturer to the Omega avionics under test, in order to provide digitized data for delivery to the interface and recording set and matching custom interface cards will have to be added within the set specifically designed to receive and prepare the incoming Omega data for temporary accumulation of complete messages in the data-rate buffer. Reading out from the buffer in a standard compact format onto the cassette tape should result in practical levels of data-collection efficiency under operational conditions in world-wide transport service. Data must be recoverable from the cassettes by playback in any of the interface recorder sets.

### Salient Characteristics

The case of the interface and recording set shall conform to the Aeronautical Radio Specification 404A in order to assure compatibility with installation requirements in business and commercial aircraft. Dimensions for the chassis, deck plates, front panel, and dust cover should not exceed those for a standard short 3/4 ATR case in height, width, and length. Other details of handles, ventilation, and mounting should conform generally to corresponding details for the cases of Omega avionics cited in ARINC Characteristic 580.

The incremented cassette recorder must be capable of: (1) rewinding tape to start, and (b) initializing digital recording system when a new tape is

placed in the recorder. A front-mounted reset button may be provided to start the tape loading sequence after tape cassette has been physically changed. At all other times, power down shall not affect restoration of normal operation upon recovery of power. Upon each power interruption, one record may be partially recorded or not recorded at all, but an IRG (inter-record gap) must be written.

A card cage for circuit cards is required to be mounted inside the case. The card cage must have sufficient capacity to include a minimum of four extra slots for 4.5" x 4.5" cards. The edge connectors for these cards should have 70 or 72 pins with 0.1" pin centering. The spacing between cards must provide sufficient clearance for use of a commercially-available universal logic cards with three wire-wrap levels and/or printed circuit cards. The edge connector shall be wired as a unibus and have the following circuits always connected:

- a. Vcc (+5 volts)
  - b. Ground
  - c. Buffer enable
  - d. Data into data buffer and controller
  - e. Clock into data buffer and controller
  - f. Clock
  - g. Sync
  - h. Data
  - i. Clock
  - j. Sync
  - k. Data
- } From external connector, type RG-58 cable
- } Shielded twisted pair, i. e., two wires plus shield from external connector

In addition to the four (4) card slots that are to be provided, for custom interfaces between the equipment under evaluation and the buffer card described below, this card cage may house also whatever circuitry is required both to buffer input and to control the recorder.

A data-rate buffer, or memory, circuit card is required which will accept data whenever buffer enable is true and data is strobed in with clock. Input data rate is to be 100Hz to 2.4kHz with data valid on positive edge of clock. If no clock is present, but buffer enable is true, unit will wait for clock. When buffer enable is false, data-rate buffer will control cassette recorder and record data as per ANSI specifications. This includes both pre- and post-amble of "AA" hex, 800 BPI, Bi 0 level-encoded data and CRC. The buffer shall be capable of storing a minimum of 2048 bits comprising all the data for one record. In order to provide better tape

utilization, buffer size shall be selectable in increments of at least 512, 1024, 1536, or 2048 bits per record. Size of buffer may be selectable by switch or by board jumpers. Buffer shall be cleared every time data has been written on tape so all memory locations not used will be padded with zeroes.

An internal power supply is required with input protected by a circuit breaker of suitable size. Set must be capable of operating from primary power of 110VAC, 50-to-440Hz with the input floating from ground. A separate DC ground must be supplied. Operation, both in an aircraft and laboratory, will be required. External power to the interface-recorder set will be shut off for operational reasons several times during the recording of data on any one cassette tape.

In addition to the power requirements of the cassette recorder, data buffer and controller and formatter, the following minimum power shall be provided for the custom interface cards:

- +5VDC 1.5A
- +12VDC 500 ma
- 12VDC 100 ma

Output of power supplies shall be consistent with good digital logic design. If switching power supplies are used, design of such shall be that under no condition shall the switching frequency be between 10kHz and 14kHz interference with Omega avionics may result.

An external connector is required at the rear of the set to mate with a connector on a military standard shock mounting rack. Capacity of the connector shall have a minimum of three pins capable of receiving RG-58, 26 pins for signals, and pins for the 110VAC power supply and ground. Connector shall be such that the set may be easily installed and removed from shock mount tray.

Tape cassettes will be supplied with this equipment which are in all respects compatible and suitable for the intended purpose. Additional cassettes must be available at reasonable cost from one or more reliable commercial sources.

Technical documentation should be provided with each set. The package should include: (a) instructions for installation describing physical size and clearance needed, recommended shock and vibration mounting, interconnections for external power and cables for interconnection with other

equipment, (b) instructions for operation, (c) maintenance procedures, precautions and list of replacement parts with identity of original sources and/or recommended alternate sources, and (d) wiring diagrams and description of data-rate buffer, internal interconnections, and other information needed to introduce custom interfacing cards.

*APPENDIX D*  
*QUESTIONS, RESPONSE, AND COMMENT FOLLOWING*  
*PRESENTATION GIVEN BY DR. J. C. LANOUE*

Question (Unidentified) You cite a 60-second trigger. Is it programmable so that one could sample every 2 minutes or every 4 minutes?

Response (Lanoue) We could change at the plant. But the 60-second update interval is there as it results in 13 hours of recording time. We received no specification for the recording time. However, the way the software is organized, the way this data management is organized, it will be a simple matter to change the format, the data rate, or anything else, without requiring any change to the hardware of the box nor to the recorder box itself.

Comment (Scavullo) You would have to be told (before modification) if a customer wanted some sampling rate other than once every 60-seconds.

Comment (Gibbs) Is it not possible that the recorder could decide how often to record samples? We can continue to grind it out every 60 seconds.

Response (Lanoue) We are relying on being able to make such decisions in the recorder where it is a simple matter to ignore the data produced between records and we will not need anything to CMC data nor do anything to the software in CMA-740.

Comment (Erikson) All we have to do to decrease sampling rate is put a counter in (to the recorder) to sense the control bits at the start of new data in the message delivered every 60 seconds by CMA-740. Of course, sampling cannot be more often than once per minute. (A switch in the interface would allow the operator to select sampling at the rate he likes.)

Response (Scavullo) I understand that on a cassette we could record your sample frame once per minute for 13 operating hours and, by electing to record on the tape a message every two minutes, we could record for 26 operating hours.

Comment (Lanoue) Such a (trade off) could be arranged with the Omega set from any manufacturer. The ability to select frames out of the available frames has to be built into the (interface) where it is quite simple.

Comment (Kennedy) Be careful because if the equipment is inaccessible as installed you won't be able to make such changes.

Response (Lanoue) It is not practical to play around with this matter. When the FAA will give such a unit to an aircraft of a carrier, it will have to preset based upon discussion between the carrier and FAA. They may agree to record for one week's flight operations on a single cassette.

Question (Carmel) Do I assume that data updated within the last 60 seconds is R-M; that is, the recorder can look at it anytime during the 60-second interval, or is the strobe interconnected between the...?

Response (Lanoue) Maybe we should examine the diagram which shows a frame constructed from signals in six bytes. There is a lot of flexibility to the software. Consider arriving at the...and of an Omega format. And you decide it is time to start a new frame. Then the software will look into the memory and pick up, for example, position data, GMT, and signal-to-noise just to name a few. It will take a snapshot of it and

duplicate the snapshot into its own memory. Then every 50 milliseconds it will take six bytes of this snapshot and deliver it to the hardware. The hardware will output electrical pulses onto the wire. Obviously the data is available only at the time of those particular bytes. The interface unit cannot ask arbitrarily for delivery of any particular byte. The interface unit waits and as soon as bytes arrive, it puts them into its own memory.

Comment (Scavullo) The initial recording by NAFEC was accomplished one frame per minute with the expectation that an event occurring within a particular lane could better be associated with that lane. At commercial jet speeds, it takes a little more than one minute to traverse an Omega lane. Experience could show that less frequent sampling will suffice. We would like to get one loaded cassette back each week from every installation. If our sampling rate were too fast, we might only be able to record during two days of flying. We will need to be able to adapt our sampling rate to the particular situation.

Response (Lanoue) Omega manufacturers should provide some basic capability of data output. On the other hand, FAA could have a new problem if it defines a different sampling characteristic for the interface card for each participating carrier.

Question (Kennedy) What would happen if you wanted to record a sample just as you fly over a mark? You are satisfied with your position, but you must wait for the counter to count to its assigned record. You would not be able to correlate

the data with that mark, or would you? Could you apply a test code on the Omega set?

Response (Lanoue) Yes. There was not a request for such a feature. To do what you suggest would require another switch somewhere with all the problems that another switch could entail. Airlines would object to that. A test code punched into the control display unit to get a trigger would add workload which most pilots do not care to do.

Comment (Scavullo) If there were a continuous flow of information at every 10 seconds, it might not help very much. We are looking for phenomena which have effects over wide areas, accumulating data by geographic cells. We are willing to accept Omega position without another reference as all indications argue against actual errors of more than two or three lanes, usually good enough to locate which 10° by 10° cell we were in at the time of a record.

Comment (Lanoue) Maybe I can add something. The only place where an onboard pilot could make the crossing of a VOR fix would be over land. And it is in such a place that he will be about to get a manual report position from a radar. So we are not adding very much more to knowledge of accuracy of the system by providing a marker picture. If you provide a marker picture you will have to correlate it with the cassette--why not simply record the position-time data. Of course, pilots won't like to do that either. If you provide a marker, then you are logically obliged to provide an entry of the record of position into the system, and, logically, it will be better to provide to go along with

the marker an indication of this the reason for quotation.

And with the data we can expect to be recorded on the interface unit that would be more realistic. But, if you just have a marker button and ask the pilot to provide a record of the coordinates, in the long term you will not decipher the data.

Question (Lyddane) Are you recording desired track, actual track, ground speed, most of the NAV primers?

Response (Lanoue) What is available is the track and track error so from those you can build up desired track, also available are the designated waypoints.

Question (Lyddane) Of what use are waypoints? Why do you want to know desired track?

Response (Lanoue) Possibly as a rough check of the direction of the aircraft. A knowledge of the desired track and waypoints can be applied to a visual inspection of the globe for a quick estimate of the situation when a particular phenomenon occurred.

Comment (Carmel) It also gives you ability to find out if there was an error, whether may have been due to an inadvertent input which is a very common occurrence.

Comment (Scavullo) We have not considered entering ATC records to verify flight plans. It is not fair to Mr. Lanoue to expect him to defend this selection of data--which we requested of him. We anticipate the possible occurrence of questions which only can be resolved after considering the available navigation data. We are mainly concerned with

sorting out exceptional or abnormal behavior attributable to effects in the propagation environment, or to interruptions of service at one of the ground stations, etc. We don't want to report erroneous data points.

Comment (Carmel) There has to be a fallout in both directions. You are looking for what FAA requires. The same effort should give the operator help in solving his particular problems. We may come to you to learn what the signal status was at a particular time, but we also need to know what else had been going on. I feel we must be able to relate this track to an event. The Omega is coupled to drive our aircraft. If there is a position glitch, say a 1-mile shift, the airplane will make a substantial movement. The pilot will be asked to make a notation about what happened at such and such a place when the aircraft moved over and made those wild turns. Benefit back to the user would be to be able to interrogate the tape to find a technical explanation.

Discussion (Lanoue) Don't you agree that in most cases, because you are coupled to an Omega system, the pilot will not write anything down except when he will be close to the data? Unless there is a profound blunder, the pilot will not know there is an error in the Omega.

Comment (Scavullo) We promise that whatever data are collected will be made available, at least as printouts. We will take your data on 9-track tape. You may want to screen out and process your own data separately. We would attempt to do any special analysis you need if you cannot do it yourself. The marginal cost of such work to us would be modest and it would fit the

FAA mission. We would, of course, protect anonymity. We would do what we could for participants. After five crossings with TWA in January 1976, it was only a month or so before we presented TWA with zerox copies of all the data we had collected with our portable recorder. I believe it helped TWA make some of its decisions.

Alan Carmel deals with an industrial fleet, operated by Continental Can and he can talk with pilots differently than an officer of a commercial carrier can talk to much larger groups of union pilots. Our planning has attempted to avoid adding to pilot workload.

Comment (Diederich) I believe we may be going too far in avoiding workload. It seems we could use a \$50. dictation voice recorder to log events in the cockpit without imposing on the pilots.

Response (Scavullo) We could not introduce audio onto the digital cassette.

Response (Erikson) If something must be copied on paper in the cockpit to note an event, the time display on the Omega set would supply an exact reference to the corresponding sample frame on the digital cassette tape.

Comment (Carmel) If the pilot is busy holding onto the aircraft, he

might not be able to get that readout.

Response (Erikson) But, if the pilot finds the paper and pencil (or the pocket voice recorder) and makes any notes at all he should be able to mark down the time.

Comment (Carmel) If he makes his notes 5-minutes later, the basic GMT is lost.

Comment (Scavullo) We hope that the basic requirements can be satisfied with the equipment we believe we can provide and that collaborating users will learn how to solve their special logging problems within their own organization.

Comment (Kennedy) I made this point when criticizing the philosophy about who triggers the recorder. If you are going to change the software and some pilots want the opportunity to trigger an event marker and others might not. Those who don't won't need to use it. But the trigger has to be local to the pilot. There are many check codes available in some of the Omega sets. Pressing an available button may make an easy way to mark an event. You've got the 60-second clock, why not have initialization code in the Omega set with which to set up the rate of sampling --thus, all recorder functions would be up front with the pilot. There is a lot of potential flexibility.

**APPENDIX E**

**INTER-ORGANIZATION PARTICIPATION AGREEMENT FORM**

APPENDIX E

AGREEMENT NO. DOT FA78NA-AP- \_\_\_\_\_

BETWEEN

DEPARTMENT OF TRANSPORTATION  
FEDERAL AVIATION ADMINISTRATION  
NATIONAL AVIATION FACILITIES EXPERIMENTAL CENTER  
ATLANTIC CITY, NEW JERSEY

AND

\_\_\_\_\_  
\_\_\_\_\_  
\_\_\_\_\_

I. PURPOSE

The purpose of this Agreement between the Federal Aviation Administration, National Aviation Facilities Experimental Center (hereinafter referred to as FAA) and \_\_\_\_\_ (hereinafter referred to as \_\_\_\_\_) is to permit the FAA to obtain Omega performance data from \_\_\_\_\_ aircraft flying intercontinental and oceanic air routes by use of government-furnished recorders with modification kits. All benefits and considerations are set forth herein.

II. SCOPE

A. The FAA shall:

1. Furnish three Omega recorders to be used for obtaining Omega performance data, along with cassettes.
2. Furnish the appropriate modification kits for the aircraft's Omega receiver system.
3. Replace the Omega recorder kits, if found faulty. If replacement is not feasible, the collection of Omega data shall be discontinued.
4. Distribute reports to \_\_\_\_\_ from data gathered solely aboard \_\_\_\_\_ aircraft as a result of the purpose of the Agreement. These reports would not be made available to any other airline without the consent of \_\_\_\_\_ given in writing.

5. Furnish to \_\_\_\_\_ any special printouts FAA can make from the data collected by the Omega recorder cassettes, if requested by \_\_\_\_\_. These printouts would not be made available to any other airline.

6. Perform all requirements set forth in Items 1 through 5 under this Article IIA at no cost to \_\_\_\_\_.

**RECORDER NONINTERFERENCE:**

(a) The recording devices furnished by the FAA for use in \_\_\_\_\_ aircraft under this Agreement will not degrade or interfere with the normal navigation function of the aircraft or the Omega system.

(b) The information obtained by the FAA from the recorders will not be used for disciplinary action with respect to flight crew performance, or given to other agencies or companies, except \_\_\_\_\_, without written approval from \_\_\_\_\_.

B. \_\_\_\_\_ shall:

1. Install the Omega recorders furnished by the FAA in a \_\_\_\_\_ aircraft selected by \_\_\_\_\_ as the aircraft best suited for the purpose set forth in this Agreement.

2. Modify \_\_\_\_\_ Omega Navigation set, utilizing the modification kit furnished by FAA, in a \_\_\_\_\_ aircraft selected by \_\_\_\_\_ as the aircraft best suited for the purposes set forth in this Agreement.

3. Remove the FAA recorders and kits from the aircraft upon completion of the term herein, and return them to the FAA.

4. Perform all requirements set forth in Items 1 through 3 under this Article IIB at no cost to the FAA.

**C. Loss of Government Furnished Property**

The loss of Government Furnished Property utilized under this Agreement will not be the responsibility of \_\_\_\_\_ unless an attempt to defraud the Government can be proven. \_\_\_\_\_ agrees, however, that it shall give as much care and security to the Government's property as it gives to its own property.

**III. TERM**

The term of this Agreement shall be a period of 2 years from the date that \_\_\_\_\_ receives the Government furnished property to be installed by \_\_\_\_\_

\_\_\_\_\_ and this period may be extended upon mutual agreement of  
\_\_\_\_\_ and the FAA for any period deemed acceptable to both parties.

**IV. SHIPMENT**

Omega recorders and kits shall be furnished to \_\_\_\_\_, or returned to the FAA, at the expense of the FAA by such method as FAA shall determine appropriate.

**V. MAILING ADDRESS**

Correspondence, or other documents, related to this Agreement shall be addressed to:

Mr. \_\_\_\_\_  
\_\_\_\_\_  
\_\_\_\_\_  
\_\_\_\_\_

Mr. Joseph J. Scavullo, ANA-330  
FAA/NAFEC  
Atlantic City, NJ 08405

**VI. CHANGES**

Any change of this Agreement shall be effected by written bilateral modification of this Agreement.

**VII. OFFICIALS NOT TO BENEFIT**

No member of, or delegate to Congress, or resident Commissioner, shall be admitted to any share or part of this contract, or to any benefits that may arise therefrom; but this provision shall not be construed to extend to this contract if made with a corporation for its general benefit.

The FAA and \_\_\_\_\_ agree to all provisions of this Agreement by affixing the signatures of their duly authorized officers below.

**FEDERAL AVIATION ADMINISTRATION**

By \_\_\_\_\_  
(Name)  
  
\_\_\_\_\_  
(Title)  
  
\_\_\_\_\_  
(Date)

By \_\_\_\_\_  
(Name)  
  
Contracting Officer  
\_\_\_\_\_  
(Title)  
  
\_\_\_\_\_  
(Date)

and this period may be extended upon mutual agreement of  
and the FAA for any period deemed acceptable to both parties.

IV. SHIPMENT

Original records and kits shall be furnished to \_\_\_\_\_, or retained to  
the FAA, at the expense of the FAA by such method as FAA shall determine  
appropriate.

V. MAILING ADDRESS

Correspondence, or other documents, related to this Agreement shall be  
addressed to:

Mr. Joseph J. Scaville, AWA-130  
FAA/AVIATION  
Atlantic City, NJ 08402

Mr. \_\_\_\_\_  
\_\_\_\_\_  
\_\_\_\_\_

VI. CHANGES

Any change of this Agreement shall be effected by written bilateral modification  
of this Agreement.

VII. OFFICIALS NOT TO BENEFIT

No member of, or delegate to Congress, or Federal Commissioner, shall  
be admitted to any share or part of this contract, or to any part of the  
may arise therefrom, but this provision shall not be construed to extend  
to this contract if made with a corporation for its general benefit.

The FAA and \_\_\_\_\_ agree to all provisions of this Agreement by  
affixing the signatures of their duly authorized officers below.

FEDERAL AVIATION ADMINISTRATION

_____	BY	_____	BY
(Name)		(Name)	
Contracting Officer			
(Title)		(Title)	
_____		_____	
(Date)		(Date)	

World Wide Omega Data Bank Conference  
Philadelphia, Pennsylvania  
Registered Attendants

Honoure Alzial  
CROUZET  
25 Rue Juls Vedrines  
Valence, France 26010

Terry Armstrong  
Tracor, Inc.  
6500 Tracor Ln.  
Austin, TX 78271

William M. Berry  
FAA ACDO 31  
1568 Willingham Dr.  
Atlanta, GA 30337

Moussa Bougnounou  
Air Afrique MTP  
Box Office 2024 Zone Entretien Roissy  
Paris, France

Alan Carmel  
Continental Can Co.  
Morristown Airport  
Morristown, NJ 07960

R. Cherry  
Capitol International Airways  
Operations Chief Pilot  
Smyrna Airport  
Smyrna, TN 37167

Dennis B. Cooper  
FAA  
800 Independence Ave.  
Washington, D.C. 20591

Charles Cram  
FAA Spectrum Management  
2100 2nd St. S.W.  
Washington, D.C. 20591

James Da Rold  
Norden Systems  
Maxess Rd.  
Melville, NY 11746

Jerald M. Davis  
NY ACDO  
181 S. Franklin Ave.  
Valley Stream, NY

P. Diederich  
The Decca Navigator Co., Ltd.  
247 Burlington Rd.  
New Malden, Surrey, UK

A. M. Ernst  
FAA ASO-FSDO-62  
Metro Airport  
Nashville, TN 37217

William M. Fanning  
NBAA  
1 Farragut Square South  
Washington, D.C. 20006

E. V. Fretwell  
ALPA  
1625 Mass. Ave. N.W.  
Washington, D.C. 20036

Keinosuke Furukawa  
Japan Air Lines  
9-1 Hanedakuku 1 chome Ota-ku  
Tokyo, Japan 144

Neil Gallon  
British Airways  
Heathrow Airport  
London, England

R. Van Gelder  
KLM Aero Carto B.V.  
Prinses Beatrix Laan 7  
The Hague, Holland

G. Gibbs  
Canadian Marconi Co.  
2442 Trenton Ave.  
Montreal, Quebec H39 1y9

Dunstan Graham  
Princeton University  
Engineering Rm. 302 EQ  
Princeton, NJ 08540

Beryl B. Green  
FAA  
Oklahoma City, OK

GAP Haynes  
Capitol International Airways  
P.O. Box 325  
Smyrna, TN 37167

David Herold  
Ohio University  
Athens, OH 45701

Robert Huhn  
FAA  
800 Independence S.W.  
Washington, D.C. 20591

Carl A. Hutchinson  
FAA  
2525 Geneva St.  
Denver, CO 80010

Ray Johnson  
Delta Air Lines  
Hartsfield Airport  
Atlanta, GA 30202

A. L. Jones  
U.S. Steel  
P.O. Box 12345  
Pittsburg, PA 15231

Paul A. C. Kennedy  
British Embassy  
British Navy Staff, Bldg. 6  
2221 Jefferson Davis Hwy.  
Arlington, VA 22202

Richard Ladzinke  
FAA  
Atlanta, GA

J. D. Lanoue  
Canadian Marconi Co.  
2442 Trenton Ave.  
Mount-Royal, Canada H3P 1Y9

J. L. Legare  
Air Afrique, MTP  
BP 20202 95712 Roissy-Ch de Gaulle  
Paris, France

Paul Levine  
Megatek Corp.  
1055 Shafter St.  
San Diego, CA 92106

Irv Lublin  
International Omega Assn.  
P.O. Box 2324  
Arlington, VA 22202

George Lyddane  
FAA Engineering Div.  
16005 Sabana Ln.  
Encino, CA 91436

Peter B. Morris  
USCG/ONSOD  
2100 2nd St.  
Washington, D.C. 20590

S. Murakami  
Japan Air Lines  
1-1 Hanedakuko 2 chome Ota-ku  
Tokyo, Japan 144

Robert E. O'Brien  
FAA  
322 Knapp Blvd.-Metro Airport  
Nashville, TN 37219

Sam Peri  
Ports of Call  
2121 Valentia Station  
Denver, CO 80220

John Pohlke  
Base Ten Systems, Inc.  
3828 Quakerbridge Rd.  
Trenton, NJ 08619

George Quinn  
FAA-ARD-732  
2100 Second St. S.W.  
Washington, D.C. 20590

Dr. Fritz M. Reder  
DRECO-COM-RF-5 (Evans)  
CENCOMS/CORADCOM  
Fort Monmouth, NJ 07703

P. R. J. Reynolds  
12 Fairway Drive  
Cold Springs Hrbr., NY 11724

H. W. Ross  
United States Steel Corp.  
P.O. Box 12345 Greater Pittsburg Airport  
Pittsburgh, PA 15231

David C. Scull  
USCG/ONSOD  
2112 Wittington Blvd.  
Alexandria, VA 22308

John H. Shaffer  
FAA  
6305 Maiden Ln.  
Bethesda, OH 20034

Thomas H. Shelton  
FAA  
1568 Willingham Dr., Suite D, Rm. 116  
College Park, GA 30337

Charles R. Stauffer  
FAA  
525 Mexico City Ave, KCI  
Kansas City, MO 64153

G. J. Taylor  
Transport Canada  
Tower C Place de Ville  
Ottawa, Canada

A. D. Thompson  
Boeing  
Rt. 2 Box 795  
Vashon Is., WA 98070

Edward Thompson  
FAA  
1568 Willingham Dr., Suite D, Rm. 116  
London, England SE17SW

M. D. Tooley  
The Decca Navigator Co., Ltd.  
9 Albert Embankment  
London, England SE17SW

Douglas E. Underwood  
Ports of Call  
2121 Valentia St.  
Denver, CO 80220

Bob Westoff  
FAA Denver ACDO  
2525 Geneva St.  
Aurora, CO 80010

S. Yamashita  
Japan Air Lines  
JAL Operation Center Bldg.  
1-1 Hanedakuko 2 chome Ota-ku  
Tokyo, Japan 144

#### NAFEC PARTICIPANTS

Joseph M. Del Balzo, ANA-1  
Albert Lupinetti, ANA-4B  
Robert Moore, ANA-180  
Jack W. Edwards, ANA-300  
Edward J. Murphy, ANA-330  
Joseph J. Scavullo, ANA-330  
Arthur A. Heavener, ANA-330  
Robert Erikson, ANA-330  
Lorraine Rzonca, ANA-330