

AD-A069 522

GTE LABS INC WALTHAM MASS

F/G 10/3

INVESTIGATION OF METHODS TO ELIMINATE VOLTAGE DELAY IN LI/SOCL₂--ETC(U)

MAR 79 C SCHLAIKJER, C A YOUNG, M DOBRUSIN

DAAB07-78-C-0558

UNCLASSIFIED

DELET-TR-78-0558-1

NL

1 OF 1

AD
A069522



END
DATE
FILMED

7-79

DDC



LEVEL II

12

Research and Development Technical Report

DELET-TR-78-0558-1

AD A 069522

in

**INVESTIGATION OF METHODS TO
ELIMINATE VOLTAGE DELAY IN
Li/SOCl₂ CELLS**

C. Schlaikjer
C.A. Young
M. Dobrusin

GTE LABORATORIES INCORPORATED
40 Sylvan Road
Waltham, Massachusetts 02154

March 1979

First Quarterly Report for Period 19 September - 19 December 1978

DISTRIBUTION STATEMENT

Approved for public release;
distribution unlimited.

DDC
RECEIVED
JUN 6 1979
C

Prepared for:

ELECTRONICS TECHNOLOGY & DEVICES LABORATORY

ERADCOM

US ARMY ELECTRONICS RESEARCH AND DEVELOPMENT COMMAND
FORT MONMOUTH, NEW JERSEY 07703

DDC FILE COPY

79 05 31 049

HISA-FM 195-78

NOTICES

Disclaimers

The citations of trade names and names of manufacturers in this report is not to be construed as official Government indorsement or approval of commercial products or services referenced herein.

Disposition

Destroy this report when it is no longer needed. Do not return it to the originator.

HISA-FM-633-78

UNCLASSIFIED

SECURITY CLASSIFICATION OF THIS PAGE (When Data Entered)

18 19 REPORT DOCUMENTATION PAGE		READ INSTRUCTIONS BEFORE COMPLETING FORM	
1. REPORT NUMBER DELET-TR-78-0558-1	2. GOVT ACCESSION NO.	3. RECIPIENT'S CATALOG NUMBER 9	
6 4. TITLE (and Subtitle) INVESTIGATION OF METHODS TO ELIMINATE VOLTAGE DELAY IN Li/SOCl ₂ CELLS.		5. TYPE OF REPORT & PERIOD COVERED Quarterly Technical rept, no. 1, 19 Sep - 19 Dec 1978.	
7. AUTHOR(s) 10 C./Schlaikjer, C.A./Young M./Dobrusin		6. PERFORMING ORG. REPORT NUMBER 78-0558-1	8. CONTRACT OR GRANT NUMBER(s) 15 DAAB07-78-C-0558
9. PERFORMING ORGANIZATION NAME AND ADDRESS GTE Laboratories, Incorporated 40 Sylvan Road Waltham, Mass. 02154		10. PROGRAM ELEMENT, PROJECT, TASK AREA & WORK UNIT NUMBERS 16 1L161102 AH47/03-483	
11. CONTROLLING OFFICE NAME AND ADDRESS US Army Electronics Technology & Devices Lab (ERADCOM), ATTN: DELET-PR Fort Monmouth, NJ 07703		12. REPORT DATE 11 Mar 1979	
14. MONITORING AGENCY NAME & ADDRESS (if different from Controlling Office) 12 27p.		13. NUMBER OF PAGES 29	
		15. SECURITY CLASS. (of this report) UNCLASSIFIED	
		15a. DECLASSIFICATION/DOWNGRADING SCHEDULE	
16. DISTRIBUTION STATEMENT (of this Report) Approved for Public Release; distribution unlimited.			
17. DISTRIBUTION STATEMENT (of the abstract entered in Block 20, if different from Report)			
18. SUPPLEMENTARY NOTES			
19. KEY WORDS (Continue on reverse side if necessary and identify by block number) Lithium-thionyl chloride cells, voltage delay, lithium passivation, inorganic electrolyte batteries, polyhedral borate, nonaqueous batteries.			
20. ABSTRACT (Continue on reverse side if necessary and identify by block number) The rate of growth of lithium chloride films on lithium in thionyl chloride containing 1.8 M LiAlCl ₄ and 1.8 M LiAlCl ₄ with 10 ⁻³ M AlCl ₃ has been measured at 25°, 55°, and 72°C, using a pulse technique. The measured capacitance and micropolarization were used to calculate the thickness and resistivity of the films. It has been found to date that the rate of growth slows drastically after a few days of standing and the films assume a nearly constant thickness. This thickness is less when (Cont.)			

DD FORM 1473 JAN 73 EDITION OF 1 NOV 65 IS OBSOLETE

Unclassified SECURITY CLASSIFICATION OF THIS PAGE (When Data Entered)

iii

406 462

LB

ABSTRACT - Continued

a slight excess of $AlCl_3$ is present, but not when the storage temperature is lower. The polyhedral borate salts $Li_2B_{10}Cl_{10}$ and $Li_2B_{12}Cl_{12}$ have been synthesized from decaborane according to techniques described in the literature. Similar measurements of LiCl film growth on lithium in $SOCl_2$ containing these salts are planned.

Unclassified

SECURITY CLASSIFICATION OF THIS PAGE(When Data Entered)

FOREWORD

Some of the work reported here was done prior to the beginning of the contract period. Reference to this material is included because of its relevance to the subject, and because the work was originally intended to be part of this contract. We refer specifically to Sections 2.5 and 3.2, concerning the conductivity and physical properties of SOCl_2 containing the lithium salts of $\text{B}_{10}\text{Cl}_{10}^-$ and $\text{B}_{12}\text{Cl}_{12}^-$.

ACCESSION for	
NTIS	White Section <input checked="" type="checkbox"/>
DDC	Buff Section <input type="checkbox"/>
UNANNOUNCED	<input type="checkbox"/>
JUSTIFICATION _____	
BY _____	
DISTRIBUTION/AVAILABILITY CODES	
Dist.	AVAIL. and/or SPECIAL
A	

TABLE OF CONTENTS

<u>Section</u>		<u>Page</u>
1	Introduction	1
2	Experimental	3
	2.1 Preparation of $\text{Li}_2\text{B}_{10}\text{Cl}_{10}$ and $\text{Li}_2\text{B}_{12}\text{Cl}_{12}$	3
	2.2 Preparation of SOCl_2 Electrolytes Containing AlCl_3 and LiAlCl_4	5
	2.2.1 The Solvent	5
	2.2.2 Aluminum Chloride and LiAlCl_4	5
	2.3 Preparation of Test Cells for Growth Rate Measurements	5
	2.4 Electrochemical Measurements - Film Growth Rate	6
	2.5 Electrochemical Measurements: Conductivity	7
3	Results and Discussions	9
	3.1 Film Growth Rates	9
	3.2 Physical Chemical Changes in Polyhedral Borate/ SOCl_2 Electrolytes	13
4	References	17

PRECEDING PAGE BLANK

LIST OF ILLUSTRATIONS

<u>Figure</u>		<u>Page</u>
1	Electrode Set Up	6
2	Conductivity Cell	8
3	Cell A After 10 Days Using a 100 μ s, 100 μ A Pulse	9
4	Cell A After 10 Days on Applying +2, +1, -2 μ A, 10 ms Pulses	9
5	d_{\min} as a Function of Time and Storage Temperature Cells, A,B Sotred at 25°C; C,D - 55°C; E,F - 72°C	10
6	R_T as a Function of Time and Storage Temperature	11
7	d_{\min} as a Function of Time Stored at Room Temperature	12
8	R_T as a Function of Time Stored at Room Temperature	12
9	Log σ vs. 1000/T for 0.25N $\text{Li}_2\text{B}_{10}\text{Cl}_{10}$ and $\text{Li}_2\text{B}_{12}\text{Cl}_{12}$ in SOCl_2	15
10	Log σ vs. 1000/T for 0.1N $\text{Li}_2\text{B}_{10}\text{Cl}_{10}$ and $\text{Li}_2\text{B}_{12}\text{Cl}_{12}$; and 0.5N $\text{Li}_2\text{B}_{10}\text{Cl}_{10}$ and LiAlCl_4 , in SOCl_2	16
11	Log σ vs. 1000/T for 0.1N and 0.25N $\text{Li}_2\text{B}_{10}\text{Cl}_{10}$ in SOCl_2 Before (Fresh) and After (Aged) Storage at Room Temperature	16

1. INTRODUCTION

The object of this work is to prepare a fundamental study of the growth of lithium chloride on lithium in thionyl chloride electrolytes containing either lithium tetrachloroaluminate, the salt now most commonly used in Li/SOCl_2 primary cells, or the lithium salt of one of the polyhedral borate anions $\text{B}_{10}\text{Cl}_{10}^{--}$ or $\text{B}_{12}\text{Cl}_{12}^{--}$. The rate of growth and the thickness of the lithium chloride film on lithium has been found to be related to the voltage delay on startup of lithium/thionyl chloride cells following long-term storage and storage at elevated temperature.¹⁻⁵ The salts, $\text{Li}_2\text{B}_{10}\text{Cl}_{10}$ and $\text{Li}_2\text{B}_{12}\text{Cl}_{12}$, were reported to alleviate voltage delay without causing significant anode corrosion when used in place of LiAlCl_4 ,⁶ although the mechanism responsible for this dramatic improvement was not established.

The thickness and resistivity of films on active metals in corrosive electrolytes has been measured using a galvanostatic pulse technique.⁷⁻¹¹ These studies have led to the development of the solid electrolyte interphase model (SEI) for these systems. Contact between lithium and solutions containing thionyl chloride causes the formation of a thin insoluble film of lithium chloride by direct reaction, which completely covers the surface. Under favorable conditions, the film protects the metal against further direct chemical attack, yet allows the anodic discharge of lithium by permitting the passage of lithium ions. If this film should become too thick, passivation and voltage delay result. The SEI, a thin compact layer of relatively uniform thickness, is overlain with a porous and much thicker layer of lithium chloride resulting from excessive corrosion of the metal.

Investigations over the past several years have demonstrated that significant improvements in the voltage delay characteristic and in reducing the corrosion of lithium anodes are possible using lithium tetrachloroaluminate as the electrolyte salt.^{3,5,12} Iron and copper are known to aggravate the growth of the lithium chloride film, and HCl and AlCl_3OH^- , products of electrolyte hydrolysis,¹³ also contribute to excessive anode film growth and corrosion. No published systematic study yet exists of cells made with $\text{LiAlCl}_4/\text{SOCl}_2$ electrolyte analyzed and treated specifically to minimize the concentration of hydrolysis products as well as transition metals, and of cells with cathodes and separators whose moisture content has specifically been measured and minimized. Therefore, the practical limit to the improvement of the delay and of anode corrosion in these cells has not been determined. If there is a limit, it should be established to provide a basis on which to claim further improvement in both of these areas together. For this

reason; we have chosen to include LiAlCl_4 electrolytes in our investigations, which encompass galvanostatic measurements of film thickness and resistivity, corrosion measurements by weight gain of lithium chips stored with electrolytes, and voltage delay and capacity measurements on complete cells as a function of storage temperature and time.

Lithium/thionyl chloride cells containing the polyhedral borate salt $\text{Li}_2\text{B}_{10}\text{Cl}_{10}$ offer significant improvement in the delay problem without causing anode corrosion when compared with state-of-the-art $\text{LiAlCl}_4/\text{SOCl}_2$ cells,¹⁴ although the mechanism responsible is unknown. If this mechanism could be understood, improvement beyond that possible with the best $\text{LiAlCl}_4/\text{SOCl}_2$ electrolyte cells might be realized using methods alternative to the expensive $\text{Li}_2\text{B}_{10}\text{Cl}_{10}$. For this reason, knowledge and understanding of the physical chemical properties of $\text{Li}_2\text{B}_{10}\text{Cl}_{10}$ in SOCl_2 are important.

2. EXPERIMENTAL

2.1 PREPARATION OF $\text{Li}_2\text{B}_{10}\text{Cl}_{10}$ AND $\text{Li}_2\text{B}_{12}\text{Cl}_{12}$

The starting materials for $\text{B}_{10}\text{Cl}_{10}^{--}$ were decaborane (Callery Chemical Co.), xylene (Fisher), and triethylamine (Eastman). The process used was similar to that reported by Hawthorne and Pilling.¹⁵ 90g of (736 mm) decaborane were dissolved in 900 ml of xylene, and 270 ml of triethylamine (1,929 mm) were added slowly with stirring. The solution was heated to $100^\circ \pm 5^\circ\text{C}$ with stirring for 3 hrs, then heated to 135°C for 5 hrs. The white precipitate $(\text{NEt}_3\text{H})_2\text{B}_{10}\text{H}_{10}$ was filtered, washed with Fisher isopropyl alcohol, and vacuum dried. The yield was 222g (688 mm) or 93.5% based on decaborane. The amine was removed with a cooled solution of 110g of NaOH (2.75 moles) in about 1 liter of water. Triethylamine was removed with a separatory funnel, and the remaining dissolved amine extracted four times with an equal volume of toluene. The toluene was cycled against an equal volume of water containing 126 ml of 12M hydrochloric acid (1.51 moles). This solution was saved. The aqueous solution containing $\text{B}_{10}\text{H}_{10}^{--}$ was slowly acidified with 86.5 ml of glacial acetic acid (1.51 moles) and diluted to 3,500 ml in a five liter round bottom flask. The flask was cooled to 0°C and treated with chlorine gas (Matheson). When the solution acquired a greenish cast, the flask was heated to boiling to remove excess chlorine. The aqueous triethylammonium chloride solution saved from the extraction described above was added slowly with stirring. The precipitated salt $(\text{Net}_3\text{H})_2\text{B}_{10}\text{Cl}_{10}$ was filtered from the solution and carefully washed. It was dissolved in a solution of 106g $\text{LiOH}\cdot\text{H}_2\text{O}$ (2.59 moles) in 550 ml of water, and the amine extracted as described above.

Recovery of $\text{Li}_2\text{B}_{10}\text{Cl}_{10}$ from the aqueous solution was similar to that described in Ref. 6. The solution was acidified with 111 ml of 12M HCl (1.34 moles) and the remaining amine, now as $(\text{NEt}_3\text{H})_2\text{B}_{10}\text{Cl}_{10}$, was removed by filtration. The solution was made basic again by addition of a slight excess of solid LiOH. An equal volume of tetrahydrofuran (Apache Chemicals) was equilibrated with the solution and separated. Subsequent smaller portions of ether were used until aliquots from the aqueous phase no longer gave a precipitate with aqueous $(\text{NEt}_3\text{H})\text{Cl}$. The etherial phase was treated with solid LiCl, which caused the separation of an aqueous phase. This was removed as it was formed. The process was continued until the solution was in equilibrium with solid LiCl. The etherial phase was placed in a distillation apparatus with a Berl saddle column and fractionated. The distillate was saved, and fresh dry tetrahydrofuran was added to the pot

periodically to replace that distilled. Crystals of solvated $\text{Li}_2\text{B}_{10}\text{Cl}_{10}$ formed in the pot. These were removed and washed with dry tetrahydrofuran, then recrystallized from the distillate. $\text{B}_{10}\text{Cl}_{10}^{--}$, not crystallized as the lithium salt, was recovered by steaming the ether off the pot residue with water and precipitating as $(\text{NET}_3)_2\text{B}_{10}\text{Cl}_{10}$. The tetrahydrofuran was recycled. $\text{Li}_2\text{B}_{10}\text{Cl}_{10}$ was heated in vacuo at 160°C until it was free of ether and water.

The starting materials for $\text{B}_{12}\text{Cl}_{12}^{--}$ were decaborane and sodium borohydride (Alfa Ventron). The process was similar to that reported by Adams, Siedle, and Grant.¹⁶ For this diglyme (bis-2 methoxyethyl ether) (Eastman) is needed. It was refluxed and distilled from lithium under argon prior to use to remove moisture, ketones, alcohols, and peroxides. 17.24g of decaborane (141 mm) was dissolved in 420 ml of diglyme and 11.6g of NaBH_4 (306 mm) was added with stirring. The mixture was refluxed overnight under argon. The precipitate, impure $\text{Na}_2\text{B}_{12}\text{H}_{12}$, was rinsed free of solvent and by-products with diethyl ether, then dissolved in water and acidified carefully to destroy lower borohydride anions. The salt $(\text{NET}_3\text{H})_2\text{B}_{12}\text{H}_{12}$ was precipitated with an excess of aqueous triethylammonium chloride to separate $\text{B}_{12}\text{H}_{12}^{--}$ from any $\text{B}_{10}\text{H}_{10}^{--}$. The decaboro derivative is very soluble in water, while the dodecaboro derivative is only slightly soluble. This was handled as described above to remove the amine, then acidified and chlorinated. The dodecaboro anion was found to be less reactive, and further chlorination at 90°C was required following the appearance of dissolved chlorine in the reaction vessel. Complete chlorination was detected when the anion no longer absorbed at 850 or 862 cm^{-1} (strong) or 2570 cm^{-1} (weak). The best derivative to use for this analysis was prepared with aqueous nickel ammine hydroxide at $\text{pH} = 10$. Addition of excess nickel to the aliquot from the reaction flask, buffered with NH_4OH , caused the separation of an insoluble salt. The salt was found to be easily filtered and dried, gave a satisfactory mixture with mineral oil used for preparing infrared mulls, and the cation absorbed only at 1260 , 1290 (shoulder), 3300 (shoulder) and 3350 cm^{-1} . When chlorination was complete, treatment was identical to that described for the purification of $\text{Li}_2\text{B}_{10}\text{Cl}_{10}$. The overall yield was 33g or 41.1% based on decaborane. A more satisfactory synthesis will be used in the future.¹⁷

Solutions of $\text{Li}_2\text{B}_{10}\text{Cl}_{10}$ and $\text{Li}_2\text{B}_{12}\text{Cl}_{12}$ in thionyl chloride were prepared by weighing the required salt into volumetric flasks in an argon-filled drybox (17 to 50 ppm H_2O). The flasks were stoppered, removed to a dryroom (<4% relative humidity), and filled with purified SOCl_2 . The solutions were violet in color.⁶

2.2 PREPARATION OF SOCl_2 ELECTROLYTES CONTAINING AlCl_3 AND LiAlCl_4

2.2.1 The Solvent

Thionyl chloride, obtained from Mobay or Hooker Chemical, contains minor amounts of SO_2Cl_2 , S_2Cl_2 , SCl_2 , and sometimes sulfur. Distillation from triphenylphosphite¹⁸ removes these impurities by reducing them to phosphate, thiophosphate, and chlorophosphate esters with low vapor pressures. Fractionation of the mixture affords a distillate with reduced amounts of these materials. SO_2 and HCl are not removed, but refluxing over lithium and fractionation was found to remove HCl .¹³ The solvent used was water white, and the HCl content was below the limit of detection using a quartz windowed 1 cm pathlength cell at 2775 cm^{-1} on a Beckman IR-10 infrared spectrophotometer.

2.2.2 Aluminum Chloride and LiAlCl_4

The AlCl_3 used for the experiments described in this report was used as received (Fluka). 241g of AlCl_3 (1.8 moles) were added to a flask under dried air (4% r.h.) containing 800 ml of distilled thionyl chloride. A 10% excess (84g, 2 moles) of lithium chloride (Foote), previously dried for 16 hrs at 160°C in vacuo was added and the mixture stirred overnight. Lithium chips were added and the mixture refluxed. As the chips darkened, more were added. Treatment for 12 to 14 hrs affords a solution essentially free of hydrolysis products.¹³ The solution was filtered through glass fiber paper into a 1 liter volumetric using glassware previously rinsed with dried SOCl_2 and brought to the mark. Solutions of AlCl_3 can be made free of AlCl_2OH ¹³ by continued reflux, but lithium chips cannot be used.

2.3 PREPARATION OF TEST CELLS FOR GROWTH RATE MEASUREMENTS

The test cells used exactly the same glass configuration as described previously,^{7,8} and the electrodes were set up as shown in Figure 1. All electrodes were made of lithium metal that had been rolled between sheets of plastic prior to assembly in order to expose fresh metal surface. The area of the working electrodes was about 2 cm^2 . The cells were assembled and filled with 1.8M $\text{LiAlCl}_4/\text{SOCl}_2$ in a dry room, ($\leq 4\%$ r.h.). Prior to filling with electrolyte the cells were rinsed with dry thionyl chloride. They were evacuated through a stopcock with the electrolyte held frozen at liquid nitrogen temperature. The electrolyte was allowed to thaw to permit it to outgas, refrozen, and the cell was reevacuated.

2.4 ELECTROCHEMICAL MEASUREMENTS - FILM GROWTH RATE

The measurements described in this and in earlier work are believed to apply to the solid electrolyte interphase only and not to the porous overlayer formed on top of the SEI. The potential of the working electrode vs. the reference electrode was monitored as a function of time with a Tektronix type 549 storage oscilloscope triggered by a Princeton Applied Research model 175 Universal Programmer. All measurements were made with short pulses of very low constant current to minimize disturbance of the film on the working electrode. These constant current pulses were obtained from the programmer by connecting it in series with a swamping resistor, 100 k Ω or greater, and much larger than the largest total resistance of any cell. Since the programmer output was a constant potential pulse (up to 10V), an essentially constant current pulse was obtained.

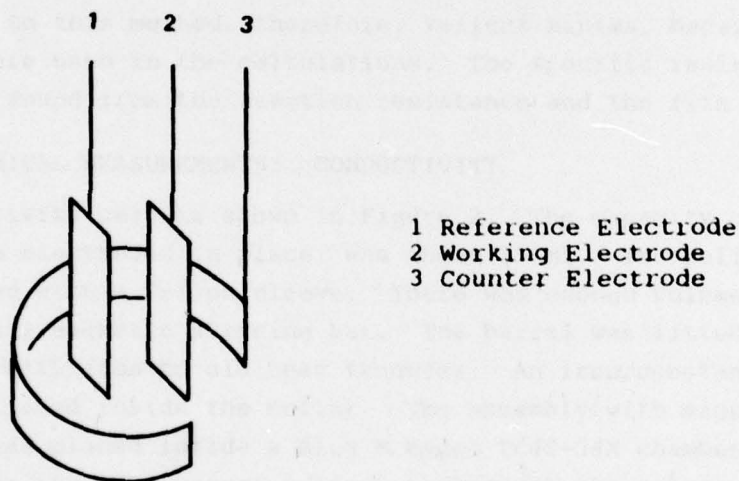

Figure 1. Electrode Set Up

The reaction resistance, R_r , was calculated from the micropolarization of the lithium anode. This was measured with single 10 ms pulses in steps of one or more microamps, anodic or cathodic.⁶ The resistance of the electrolyte was usually negligible compared with the resistance of the film. The potential of the working vs. the reference electrode was a linear function of the applied constant current, over the time interval of the measurement, and R_r was equal to the slope.

Interfacial capacitance and solution resistance, if any, were calculated from measurements using pulses of higher current, but shorter duration. Single 100 μ s anodic pulses of 100 μ A were applied to the working electrode.⁷

The initial very rapid rise reflects the solution resistance. The slope of the subsequent trace represents the interfacial capacitance of the working electrode⁷ according to:

$$C = i / \left(\frac{dv}{dt} \right)_{t=0} \quad (1)$$

where i is the current density, v the potential, and t the time. The capacitance was used to measure the film thickness⁹ according to:

$$d = \frac{\epsilon}{C \pi 3.6 \times 10^{12}} \quad (2)$$

where ϵ is the dielectric constant of LiCl. The actual area of the working electrode was assumed to be the same as the geometric area, while, in fact, the actual area was somewhat larger due to roughness. The values of d found according to this method, therefore, reflect minima, because the minimum areas were used in the calculations. The specific resistivity of the film may be found from the reaction resistance and the film thickness.

2.5 ELECTROCHEMICAL MEASUREMENTS: CONDUCTIVITY

The conductivity cell is shown in Figure 2. The capacity of the barrel, with the electrodes in place, was about 25 ml. The polished 19/22 joints were lined with a Teflon sleeve. There was enough volume at the bottom for a small magnetic stirring bar. The barrel was fitted with an aluminum collar with fins to aid heat transfer. An iron/constantan thermocouple was positioned inside the collar. The assembly with magnetic stirrer and ring stand was placed inside a Blue M model TC40-34X chamber with a small fan to keep the temperature uniform throughout the volume. The cell was calibrated before every run using 0.1 molar aqueous potassium chloride. Resistance readings were taken using a General Radio model 1656 impedance bridge with square wave excitation from 1 to 4 kHz, and a Tektronix oscilloscope. Readings were taken starting at about +55°C, cooling 10°C at a time, equilibrating 1 to 2 hrs, then reading again. The minimum temperature was about -60°C. Readings were then taken during successively higher temperatures, from -60°C back up to +55°C.

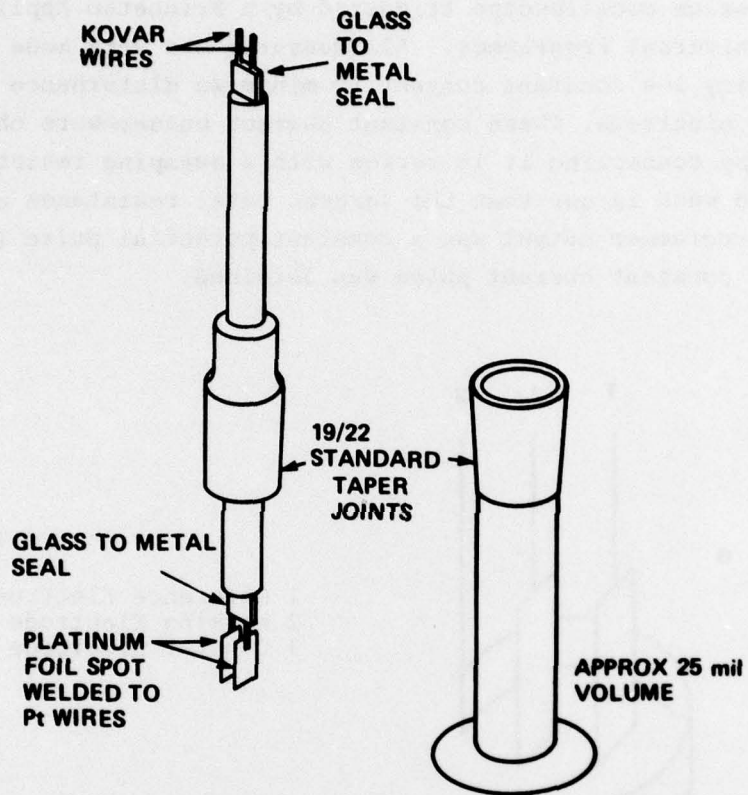

ALL PARTS FABRICATED IN PYREX
EXCEPT AS NOTED

Figure 2. Conductivity Cell

3. RESULTS AND DISCUSSIONS

3.1 FILM GROWTH RATES

Typical photographs of storage oscilloscope traces used to calculate values of C and R_r are shown in Figures 3 and 4. Figure 3 shows the trace used to measure C for Cell A, stored 10 days at 25°C, by applying a 100 μ s pulse. Figure 4 shows four micropolarization measurements for the calculation of R_r in the same cell. The minimum thickness, d_{\min} , is plotted against storage time at three different temperatures for six different cells in Figure 5. The reaction resistance for the same cells is plotted vs. time in Figure 6.

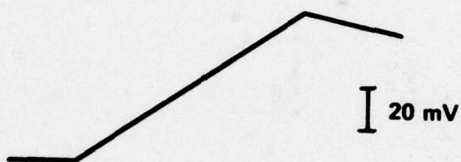

Figure 3. Cell A After 10 Days Using a 100 μ s, 100 μ A Pulse. Tracing of photograph of storage oscilloscope trace

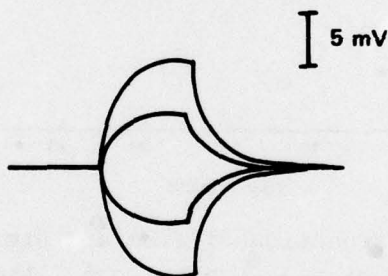

Figure 4. Cell A After 10 Days on Applying +2, +1, -2 μ A, 10 ms Pulses. Tracing of photograph of storage oscilloscope trace.

The degassing process seemed to have no significant effect on the results. In one of the test cells, measurements of interfacial capacitance of the micropolarization made prior to degassing did not differ from measurements made following two consecutive degassing operations.

The values of R_r and d_{\min} reported here are significantly higher than those previously reported,^{8,9} although some scatter was noted in the data. Reproducibility in the measurement of R_r and d_{\min} is important if any meaningful comparisons of film growth rates are to be made between electrolytes prepared using LiAlCl_4 and those prepared using $\text{Li}_2\text{B}_{10}\text{Cl}_{10}$ or $\text{Li}_2\text{B}_{12}\text{Cl}_{12}$. We noted that our procedure for refluxing of electrolytes was not carried out during the course of the previous investigations. Although our reason

for refluxing the electrolytes was to remove hydrolysis products, excess aluminum chloride may also have been removed during refluxing. For this reason an additional cell was constructed, and a sufficient amount of a solution of AlCl_3 in SOCl_2 , dried by refluxing without lithium, was added to the electrolyte to make the concentration

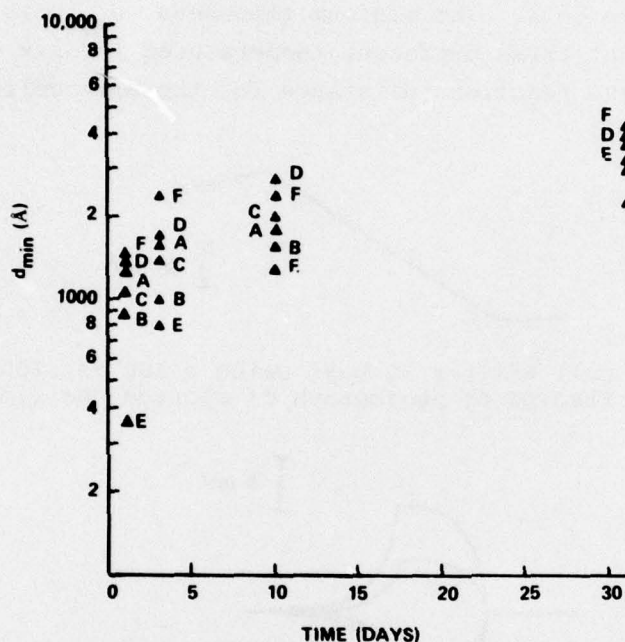

Figure 5. d_{\min} as a Function of Time and Storage Temperature
Cells A,B Stored at 25°C; C,D - 55°C; E,F - 72°C

10^{-3} molar in excess aluminum chloride. The total volume of electrolyte was about 20 ml and the total surface area of all lithium present was about 12 cm^2 . The AlCl_3 present was thus equivalent to a layer of LiCl about 342 nm thick

$$20 \text{ ml} \times 10^{-3} \text{ mm ml}^{-1} = 2 \times 10^{-2} \text{ mm AlCl}_3 \text{ of LiCl}$$

$$8.48 \times 10^{-4} \text{ g of LiCl means } 4.10 \times 10^{-4} \text{ cm}^3 \text{ of LiCl}$$

$$\text{Layer thickness} = \frac{4.10 \times 10^{-4} \text{ cm}^3}{12 \text{ cm}^2} = 3.42 \times 10^{-5} \text{ cm}$$

The cell was stored at room temperature, as were cells A and B. The thickness d_{\min} for the new cell as a function of time is compared with d_{\min} for cells

A and B in Figure 7, while the reaction resistance is compared in Figure 8. Both were found to be lower.

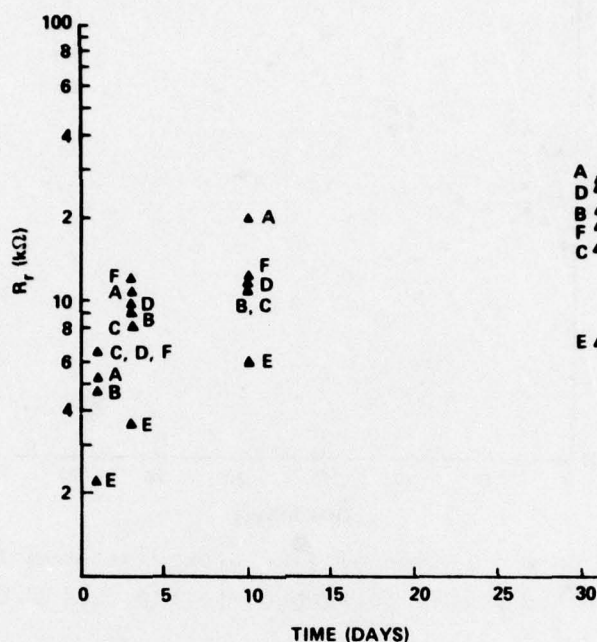

Figure 6. R_r as a Function of Time and Storage Temperature. For temperatures see Figure 5.

The purposeful addition of excess AlCl_3 to electrolyte in order to reduce voltage delay has been discussed by Marincic and Lombardi.^{3,19} In their experiments, aluminum chloride was present in the solution at 10 m% greater than the amount of lithium. At this level, the aluminum chloride was found to be highly corrosive of the lithium. It is not known what concentration of aluminum chloride remains in 1.8M LiAlCl_4 which has not been refluxed following the addition of excess solid lithium chloride, but it is clear that minute concentrations of AlCl_3 will affect the rate and extent of film growth.

Alleviation of the voltage delay problem by the addition of excess AlCl_3 offers two disadvantages. First, the effect cannot be a lasting one, since AlCl_3 is used up in the process of removing the film; second, anode corrosion and lost of solvent by reduction occur. Therefore, addition of more AlCl_3 to increase the time interval over which it will effectively remove the film is self-defeating, since the shelf life is reduced. We do not recommend pursuing this technique for reducing the voltage delay.

We believe that our results with refluxed electrolyte presented in Figures 5 and 6 represent a more accurate determination of the film growth rate in the presence of LiAlCl_4 .

The results plotted in Figures 5 and 6 reveal no significant dependency of the thickness or reaction resistance of the solid electrolyte interphase upon the temperature of storage. The data showed some scatter, but this problem also appeared in earlier work⁹ and may be related to differences in roughness.

The storage temperature, while it did not significantly affect the thickness of the inner film, has been reported to affect the magnitude of the voltage delay.²⁰ The inner film probably does not affect the voltage delay, since it is thinner than the total layer of LiCl by an order of magnitude.¹ The outer film or overlayer is most likely the main cause of voltage delay.¹¹ The overlayer likely forms as the result of the dereliction of the inner layer or SEI, which then reforms by further lithium corrosion. The rate at which materials from the electrolyte are able to penetrate or damage the SEI may be temperature dependent. If damage to the SEI is severe enough, the overlayer could build to the point where it loses most of its porosity, causing passivation.

As our studies progress, cells analyzed by the pulse technique may passivate to the point where measurements will reflect the resistivity of the overlayer as well as of the SEI.

Many of the earlier studies concerning the delay problem used $\text{Li}/\text{SOCl}_2/\text{C}$ cells which were discharged at relatively high current density. The lithium was anodized until the passivating film was essentially separated from the metal.^{2,3} While this test is more closely related to the problem as it would be encountered by a customer attempting to use the cell, several disadvantages are apparent. The method is destructive, and cells cannot be used for tests following further storage. The result is only qualitative, and replicate cells often do not show similar characteristics.^{3,20} Such test cells do not have reference electrodes, and polarization due to anode passivation is often confounded with cathode polarization. The pulse technique offers solutions to all of these problems.

3.2 PHYSICAL CHEMICAL CHANGES IN POLYHEDRAL BORATE/ SOCl_2 ELECTROLYTES

The conductivities of $\text{Li}_2\text{B}_{10}\text{Cl}_{10}$ and $\text{Li}_2\text{B}_{12}\text{Cl}_{12}$ were measured as a function of temperature at 0.1N, and 0.25N; and the conductivities of $\text{Li}_2\text{B}_{10}\text{Cl}_{10}$ and LiAlCl_4 were measured as a function of temperature at 0.5N. The results are plotted in Figures 9 and 10. The conductivities of solutions of $\text{Li}_2\text{B}_{10}\text{Cl}_{10}$ were taken several hours after preparation, and were not reproducible between the cooling and warming cycles except at the highest concentration. Measurements for $\text{Li}_2\text{B}_{12}\text{Cl}_{12}$ and LiAlCl_4 were reproducible.

Figure 11 shows log conductivity vs. the reciprocal of the absolute temperature for "fresh" 0.1 and 0.25N $\text{Li}_2\text{B}_{10}\text{Cl}_{10}$ compared with "aged" solutions, the 0.1N solution having been remeasured after 19 days and the 0.25N solution after nine days. Both were now reproducible between the cooling and the warming cycles, but the conductivities were from 30% to 80% higher than they had been.

Solutions containing $\text{Li}_2\text{B}_{10}\text{Cl}_{10}$ were found to have formed white crystalline precipitates during aging, which were identified as pure lithium chloride. The supernatant solutions contained the same concentration of $\text{B}_{10}\text{Cl}_{10}^{--}$, measured gravimetrically using aqueous tetraphenylarsonium chloride or triphenylmethylphosphonium bromide and hydrolyzed aliquots from the electrolyte solutions. Infrared spectra showed that the anions had not been altered. White crystals of LiCl also formed in flasks containing SOCl_2 solutions of $\text{Li}_2\text{B}_{12}\text{Cl}_{12}$, but the rate of solvolysis was far slower, taking several months rather than several days.

The conductivity of these solutions is likely affected by the degree of dissociation and the ionic mobility of the resulting ions. Lithium tetrachloroaluminate may be more conductive at 0.5N than is $\text{Li}_2\text{B}_{10}\text{Cl}_{10}$ because the mobility of AlCl_4^- is higher than $\text{B}_{10}\text{Cl}_{10}^{--}$ due to its smaller size. Its univalent charge would allow greater ionic dissociation of LiAlCl_4 relative to $\text{Li}_2\text{B}_{10}\text{Cl}_{10}$. The increase in conductivity noted on aging $\text{Li}_2\text{B}_{10}\text{Cl}_{10}$ solutions could have resulted from the gradual formation of solvated $\text{B}_{10}\text{Cl}_{10}^{--}$, the shielding of the negative charge, and greater dissociation of the remaining species. If LiCl is also formed in the process, then a possible mechanism would be as follows:

Prior to aging:

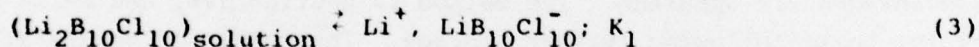

Aging Process:

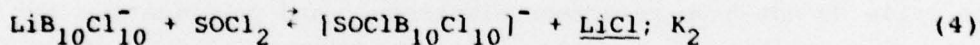

Dissociation in aged solution:

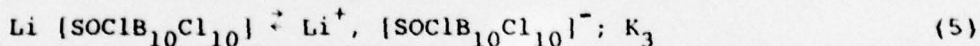

$$K_3 > K_1$$

The contribution which the anion $\text{B}_{10}\text{Cl}_{10}^{--}$ makes to the alleviation of the voltage delay may be related to the equilibria noted in Eqs. (3) through (5). Dey has noted that $\text{B}_{10}\text{Cl}_{10}^{--}$ reduces the delay relative to an AlCl_4^- - only electrolyte when both anions are present at the same time.²¹ This

would indicate that the $B_{10}Cl_{10}^{--}$ anion plays an active role in reducing the delay, not just as a passive substitute for $AlCl_4^-$. Equation (4) shows that solid lithium chloride could be in equilibrium with species present in solution, even though the solubility of lithium chloride itself would not be increased by the presence of $B_{10}Cl_{10}^{--}$. Since the ratio of surface area to volume of smaller crystals of LiCl is greater than for larger crystals, equilibrium of solid LiCl with the electrolyte would encourage growth of larger crystals at the expense of smaller ones. This would tend to keep pores in the layer above the SEI open; thus minimizing the delay.

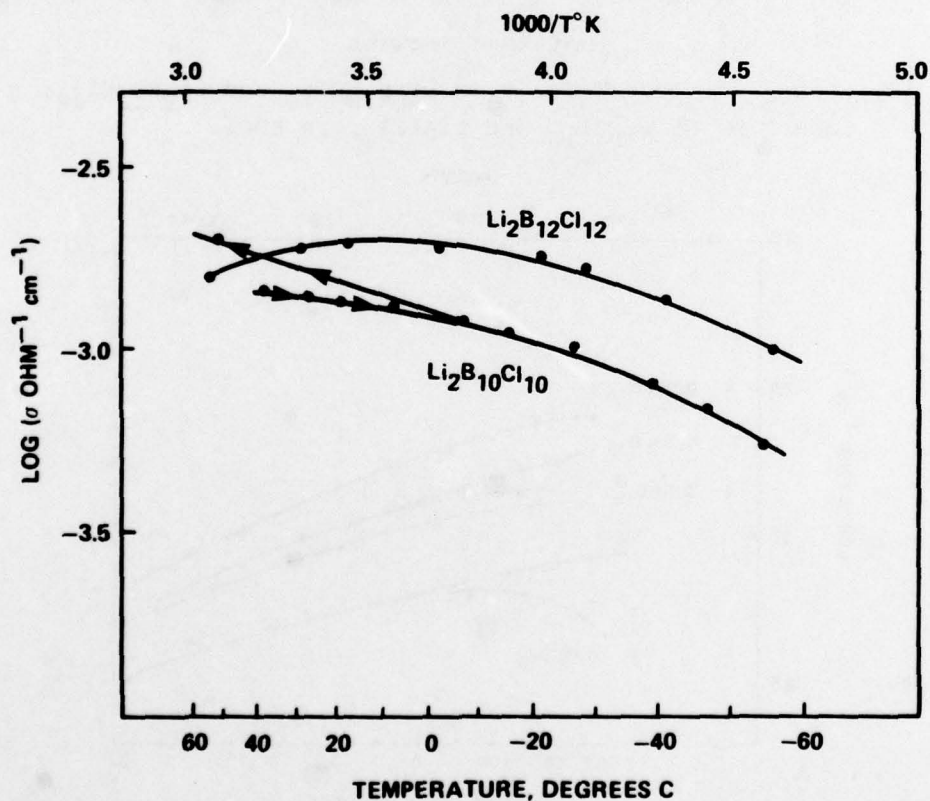

Figure 9. Log σ vs. $1000/T$ for 0.25N $Li_2B_{10}Cl_{10}$ and $Li_2B_{12}Cl_{12}$ in $SOCl_2$

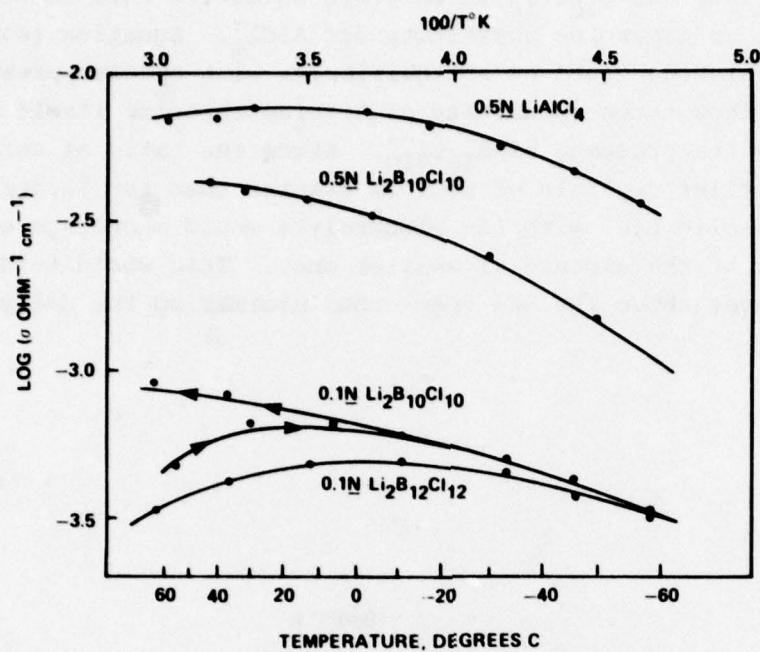

Figure 10. Log σ vs. $1000/T$ for 0.1N Li₂B₁₀Cl₁₀ and Li₂B₁₂Cl₁₂; and 0.5N Li₂B₁₀Cl₁₀ and LiAlCl₄, in SOCl₂

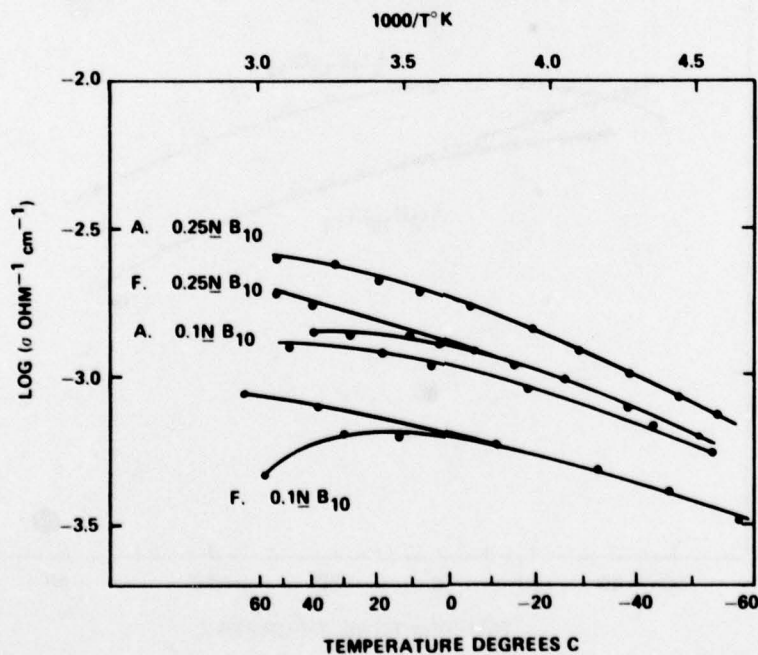

Figure 11. Log σ vs. $1000/T$ for 0.1N and 0.25N Li₂B₁₀Cl₁₀ in SOCl₂ Before (Fresh) and After (Aged) Storage at Room Temperature

4. REFERENCES

1. A.N. Dey, C.R. Schlaikjer, Proc. Power Sources Symposium 26, 47 (1974).
2. A.N. Dey, Report DELET-TR-74-0109-F (July 1978).
3. N. Marincic, A. Lombardi, ECOM 74-0108-F (April 1977).
4. D.R. Cogley, M.J. Turchan, ECOM-0030-1 (February 1974).
5. J.R. Driscoll, et al., ECOM 74-0030-11 (October 1976).
6. C.R. Schlaikjer, U.S. Patent 4,020,240.
7. E. Peled, H. Straze, J. Electrochem. Soc. 124, 1030 (1977).
8. Y. Avigal, E. Peled, J. Electroanal. Chem. 76, 135 (1977).
9. E. Peled, H. Yamin, submitted for publication to Proc. of Power Sources Symposium 28. (1978).
10. E. Peled, Abstract Number 4, Electrochem. Soc. Fall Meeting, Atlanta (October 1977).
11. E. Peled, C.R. Schlaikjer, N. Marincic, Abstract #553, Electrochem. Soc., Spring Meeting, Seattle, Washington (May 1978).
12. D.L. Chua, W.C. Merz, W.S. Bishop, Proc. 26th Power Sources Symposium, p. 33 (1976).
13. C.R. Schlaikjer, F. Goebel, N. Marincic, Abstract 16, Electrochem. Soc. Fall Meeting, Atlanta, GA, October 1977; to be published Electrochemical Society (April 1979).
14. C.R. Schlaikjer, 28th Power Sources Symposium, Atlantic City, New Jersey (June 1978).
15. M.F. Hawthorne, R.L. Pilling, Inorganic Syntheses 9, 16 (1967).
16. R.N. Adams, A.R. Siedle, J. Grant, Inorg. Chem. 3, 461 (1964).
17. H.C. Miller, E.L. Muetterties, Inorganic Synthesis 10, 81 (1967).
18. L. Friedman, W.P. Wetter, J. Chem. Soc., 36 (1967).
19. N. Marincic, A. Lombardi, U.S. Patent 4,087,594.
20. N. Marincic, A. Lombardi, C.R. Schlaikjer, Proc. of Power Sources Symposium 27, 37 (1976).
21. A.N. Dey, U.S. Patent 4,071,664 (January 31, 1978).

DISTRIBUTION LIST

DEFENSE DOCUMENTATION CENTER ATTN: DDC-TCA CAMERON STATION (BLDG 5) ALEXANDRIA, VA 22314 (12)	COMMANDER US ARMY ELECTRONICS R&D COMMAND FORT MONMOUTH, NJ 07703 1 DELET-P 1 DELET-DD 2 DELET-DT 1 DELSD-L (TECH LIB) 2 DELSD-L-S (STINFO) 10 DELET-PR (WISHVENDER K. BEHL)
COMMANDER NAVAL OCEAN SYSTEMS CENTER ATTN: LIBRARY SAN DIEGO, CA 92152 (01)	COMMANDER US ARMY COMMUNICATIONS R&D COMMAND FORT MONMOUTH, NJ 07703 1 USMC-LNO
CDR, NAVAL SURFACE WEAPONS CENTER WHITE OAK LABORATORY ATTN: LIBRARY CODE WX-21 SILVER SPRING, MD 20910 (01)	NASA SCIENTIFIC & TECH INFO FACILITY BALTIMORE/WASHINGTON INTL AIRPORT PO BOX 8757, MD 21240 (01)
COMMANDANT, MARINE CORPS HQ US MARINE CORPS ATTN: CODE LMC WASHINGTON, DC 20380 (02)	Mr. Donald Mortel AF Aero Propulsion Lab Attn: AFAPL-POE-1 Wright-Patterson AFB, OH 45433 (1)
ROME AIR DEVELOPMENT CENTER ATTN: DOCUMENTS LIBRARY (TILD) GRIFFISS AFB, NY 13441 (01)	Mr. Richard E. Oderwald Department of the Navy Hqs., US Marine Corps Code LMC 4 Washington, DC 20380 (1)
AIR FORCE GEOPHYSICS LAB/SULL ATTN: S-29 HANSCOM AFB, MA 01731 (01)	Commander Harry Diamond Laboratories Attn: DELHD-RDD (Mr. A. Benderly) 2800 Powder Mill Road Adelphi, MD 20783 (1)
HQDA (DAMA-ARZ-D/DR. F.D. VERDERAME) WASHINGTON, DC 20310 (01)	Electrochimica 2485 Charleston Road Mountain View, CA 94040 Attn: Dr. Eisenberg (1)
CDR, HARRY DIAMOND LABORATORIES ATTN: LIBRARY 2800 POWDER MILL ROAD ADELPHI, MD 20783 (01)	Dr. Hugh Barger P.O. Box 2232 Davidson, NC 28036 (1)
DIRECTOR US ARMY MATERIEL SYSTEMS ANALYSIS ACTV ATTN: DRXSY-MP ABERDEEN PROVING GROUND, MD 21005 (01)	Energy Storage & Conversion Dept. T.R.W. Systems One Space Park Redondo Beach, CA 90278 Attn: Dr. H.P. Silverman (1)
CDR, US ARMY SIGNALS WARFARE LAB ATTN: DELSW-OS VINT HILL FARMS STATION WARRENTON, VA 22186 (01)	
COMMANDER US ARMY MOBILITY EQP RES & DEV CMD ATTN: DRDME-R FORT BELVOIR, VA 22060 (01)	

Sanders Associates, Inc. 24 Simon Street Mail Stop NSI-2208 Nashua, NH 03060 Attn: J. Marshall (1)	Power Conversion, Inc. 70 MacQuesten Pkwy Mount Vernon, NY 10550 Attn: Stuart Chodosh (1)
Dr. D. Pouli Portfolio Manager Hooker Chemicals & Plastics Corp. M.P.O. Box 8 Niagara Falls, NY 14302 (1)	Dr. Leonard Nanis G207 S.R.I. Menlo Park, CA 94025 (1)
Dr. J.J. Auburn, Rm. 1A-317 Bell Laboratories 600 Mountain Ave Murray Hill, NJ 07974 (1)	Frank Murphy/SB331 Naval Underwater Systems Center Newport Laboratory Newport, RI 02840 (1)
NASA Lewis Research Center Mail Stop 6-1 2100 Brookpark Road Cleveland, OH 44101 Attn: Dr. Stuart Fordyce (1)	Mr. Joe McCartney Naval Undersea Center Code 608 San Diego, CA 92132 (1)
EIC Inc. Attn: S.B. Brummer Newton, MA 02158 (1)	Altus Corp. Attn: Douglas Clader 400 Page Mill Road Palo Alto, CA 94306 (1)
J. Bene MS 488 NASA Langley Research Center Hampton, VA 23665 (1)	Mr. Eddie T. Seo Research and Development Division The Gates Rubber Co. 999 S. Broadway Denver, CO 80217 (1)
Mr. Sidney Gross Mail Stop 8C-62 Boeing Aerospace Company P.O. Box 3999 Seattle, WA 98124 (1)	Transportation Systems Center Kendall Square Cambridge, MA 02142 Attn: Dr. Norman Rosenberg (1)
Foot Mineral Company Route 100 Exton, PA 19341 Attn: Dr. H. Grady (1)	Honeywell, Inc. 104 Rock Road Horsham, PA 19044 Attn: C. Richard Walk (1)
Sanders Associates, Inc. Sonobuoy Division 95 Canal Street Nashua, NH 03060 Attn: Mr. David Dwyer (1)	Eagle-Picher Industries, Inc. Electronics Division Attn: Mr. Robert L. Higgins P.O. Box 47 Joplin, MO 64801 (1)
Yardney Electric Company 82 Mechanic Street Pawcatuck, CT 02891 Attn: Mr. William E. Ryder (1)	P.R. Mallory & Co., Inc. Northwest Industrial Park Burlington, MA 01803 Attn: Dr. Per Bro (1)

Exxon Research and Engineering Co.
Corporate Research Laboratory
Linden, NJ 07036
Attn: Dr. R. Hamlen (1)

GTE Sylvania Inc.
77 A Street
Needham Heights, MA 02194
Attn: Mr. Richard Pabst (1)

Union Carbide Corporation
Parma Research Center
P.O. Box 6116
Cleveland, OH 44101 (1)

North American Rockwell Corp.
Atomics International Division
Box 309
Canoga Park, CA 91304
Attn: Dr. L. Heredy (1)

University of California
Department of Science & Research
Santa Barbara, CA 93100
Attn: Dr. J. Kennedy (1)

Gulton Industries, Inc.
Metuchen, NJ 08840
Attn: Mr. S. Charlip (1)

Argonne National Laboratories
9700 South Cass
Argonne, IL 60439
Attn: Dr. E.C. Gay (1)

General Motors Corp.
Research Laboratories
General Motors Technical Center
12 Mile and Mounds Roads
Warren, MI 48090
Attn: Dr. J.L. Hartman (1)

P.R. Mallory & Co., Inc.
S. Broadway
Tarrytown, NY 10591
Attn: J. Dalfonso (1)

General Electric Research &
Development Center
P.O. Box 8
Schenectady, NY 12301
Attn: Dr. Stefan Mitoff (1)

The Electric Storage Battery Co.
Carl F. Norburg Research Center
19 W. College Ave
Yardley, PA 19067
Attn: Dr. A. Salkind (1)