

AD-A069 742

NAVAL RESERVE RESEARCH LAB 522 SEATTLE WA
ADAPTIVE SIGNAL PROCESSING RELATIONSHIP TO ADAPTIVE OBSERVER PA--ETC(U)
JUL 77 D O MOLNAR, G L MITCHELL, R G CLAPHAM
NRRL-522-77-1

F/G 20/1

UNCLASSIFIED

NL

1 OF 1
AD
A069 742



END
DATE
FILMED
7-79
DDC

LEVEL

12

NRRL 522 Report 77-1

Adaptive Signal Processing
Relationship to Adaptive
Observer Parameter Identification

July 1, 1977

by:

LCDR D. O. Molnar

LCDR G. L. Mitchell

LCDR R. G. Clapham



Abstract

The acoustic signal processing method of LMS adaptive filtering is related to the problem of system parameter identification. Adaptive signal processing is dictated by the nonstationary ocean acoustic environment. Improvements in adaptive signal processing appear possible by relating appropriate results from the parameter identification field. The "Adaptive Observer Parameter Identification" method appears to contain Widrow's LMS filter as a special case.

This document has been approved
for public release and sale; its
distribution is unlimited.

79 06 08 076

DDC FILE COPY
A069742

UNCLASSIFIED

SECURITY CLASSIFICATION OF THIS PAGE (WHEN DATA ENTERED)

9 Project rept Jan-Jul 77

REPORT DOCUMENTATION PAGE

READ INSTRUCTIONS BEFORE COMPLETING FORM

1. REPORT NUMBER		2. GOV'T ACCESSION NUMBER		3. RECIPIENT'S CATALOG NUMBER	
4. TITLE (AND SUBTITLE) Adaptive signal processing relationship to adaptive observer parameter identification				5. TYPE OF REPORT/PERIOD COVERED Project Jan - July 1977	
7. AUTHOR(S) 10 D.O./Molnar, G.L./Mitchell, R.G./Clapham				6. PERFORMING ORG. REPORT NUMBER 14 NRRL 522-77-1	
9. PERFORMING ORGANIZATIONS NAME/ADDRESS Naval Reserve Research Lab 522 860 Terry Ave. No. Seattle, Wa. 98104				8. CONTRACT OR GRANT NUMBER(S)	
11. CONTROLLING OFFICE NAME/ADDRESS Naval Reserve Center 860 Terry Ave. No. Seattle, Wash. 98104				10. PROGRAM ELEMENT, PROJECT, TASK AREA & WORK UNIT NUMBERS 11 Jul 77	
14. MONITORING AGENCY NAME/ADDRESS (IF DIFFERENT FROM CONT. OFF.)				12. REPORT DATE July 1, 1977	
				13. NUMBER OF PAGES 34 12 36 p.	
				15. SECURITY CLASSIFICATION (OF THIS REPORT) Unclassified	
				15a. DECLASSIFICATION DOWNGRADING SCHEDULE	

16. DISTRIBUTION STATEMENT (OF THIS REPORT)
Approved for public release, distribution unlimited

17. DISTRIBUTION STATEMENT (OF THE ABSTRACT ENTERED IN BLOCK 20, IF DIFFERENT FROM REPORT)

18. SUPPLEMENTARY NOTES

19. KEY WORDS (CONTINUE ON REVERSE SIDE IF NECESSARY AND IDENTIFY BY BLOCK NUMBER)

Acoustic	Parameter identification	Line enhancement
Signal processing	Modem	Filter
Adaptive	Sonar	Maximum entropy
Matched filter	Anti submarine warfare	
	Noise cancelling	

20. ABSTRACT (CONTINUE ON REVERSE SIDE IF NECESSARY AND IDENTIFY BY BLOCK NUMBER)

The acoustic signal processing method of LMS adaptive filtering is related to the problem of system parameter identification. Adaptive signal processing is dictated by the non-stationary ocean acoustic environment. Improvements in adaptive signal processing appear possible by relating appropriate results from the parameter identification field. The "Adaptive Observer Parameter Identification" method appears to contain Widrow's LMS filter as a special case.

411220 B

HD-188 REV 11/74

I. INTRODUCTION

Accession For	NTIS GEMAI
	DIC TAB
	Unannounced
	Justification
By	
Distribution/	
Availability Codes	
Availand/or	special
Dist	A

Antisubmarine warfare is difficult now and is getting increasingly more difficult. The problem is detection and can be described as decreasing signal to noise ratio. Signals are getting weaker as a result of the acoustic coatings, quieter propulsion systems and operating procedures designed to reduce noise. Ambient noise is increased as the result of more ocean traffic, offshore oil drilling, etc. The answer is processing gains to offset this signal to noise ratio loss. Conventional stationary processing techniques can be optimized for a given circumstance but degrade when propagation conditions or noise source statistics change.

Since the ocean acoustics problem is nonstationary what is needed is an adaptive system that efficiently improves signal to noise ratio. Adaptive filters such as Widrow's^{1,2,3,4} LMS (Least Mean Square) filter holds promise for superior performance over stationary filters. The adaptive or slowly varying filter problem can be reinterpreted as a parameter identification problem.^{4,5,6,7} With this reinterpretation, recent developments in adaptive control systems theory become directly applicable. One such theory, the adaptive observer parameter identification (AOPI)^{5,6,7} approach contains the LMS algorithms in a special case. The AOPI formulation method provides greater flexibility and, hence, potential efficiency

in adaptive noise reduction filter design. This proposal is to investigate the LMS transversal filtering methods as related to signal model identification and, hence, make the connection to be more general model identification methods from control systems discipline.

Considering a surface vessel receiving acoustic signals, the adaptive filtering system employs a Widrow LMS filter in two ways. First, the ship's self noise is removed by the noise canceller. Next, the white noise is removed leaving the deterministic signal lines by the line enhancer.^{1,2,3}

Both the noise canceller and the line enhancer functions can be interpreted as parameter identification problems. That is, the filters achieve their objectives by identifying or modeling suitable transfer functions. Both the noise canceller and the line enhancer are implemented by a Widrow LMS transversal filter which is constrained to model transfer function zeros only. This constraint makes the LMS transversal filter inefficient in modeling systems containing poles.

The newly developed recursive filter³ is able to model poles directly and, hence, is more efficient. A recursive filter is a combination of two transversal LMS filters, where one filter is in the feedback path accomplishing pole identification. A recursive filtering is an

efficient pole-zero model identifier, hence, when used as a noise canceller or line enhancer, it has the potential for a better overall filtering in a more efficient manner. There are several areas of research interest. (1) The transversal filter,³ (as a pole model identifier, what are its convergence properties?), (2) The relationship of the transversal filter³ to more general model identifiers from the control system identification discipline, etc. The relationship between the specific parameter identification algorithm known as the adaptive observer parameter identifier (AOPI) to a recursive filter and the constrained LMS filter is of interest. The interest in this latter relationship is prompted by the generality of the AOPI algorithm in that it appears to contain the recursive filter and the nonrecursive LMS filters as special cases. Preliminary results are presented here connecting the LMS transversal filter to the AOPI parameter identification algorithms.

A potentially important application of the above theory is in the integration of passive hydrophones for better signal detection and estimation. Briefly, control system estimation techniques (Kalman filtering) require models of various error processes - the missing model for hydrophone integration is that of the acoustic propagation error model. Results with adaptive signal processing indicate that sound propagation models are available in the filter weights, hence, Kalman filter integration of sonar sensors is conceptually possible - with a potential for improved submarine detection/estimation. Recently developed charge-coupled devices promises wider application of LMS transversal filtering.

II. ADAPTIVE LMS FILTER APPLICATIONS AND REINTERPRETATION

Two common LMS filter applications can be reinterpreted as parameter identification problems. This reinterpretation illustrates the fundamental limitation of the conventional LMS filter forms, and hence, motivates interest in the theoretically more efficient recursive filter⁴ and related AOPI^{5,6,7} derived filters.

A. If a noise reference is available for instrumentation, a noise canceller can be constructed. It has two inputs as shown in Figure 1.

- signal + noise
- noise reference

The noise supplied to the reference input does not generally have the same phase and amplitude as the noise contained in the noise + signal term. The filter adjusts the reference noise amplitude and phase so as to match the noise contained in the signal, and then subtractively cancels it.

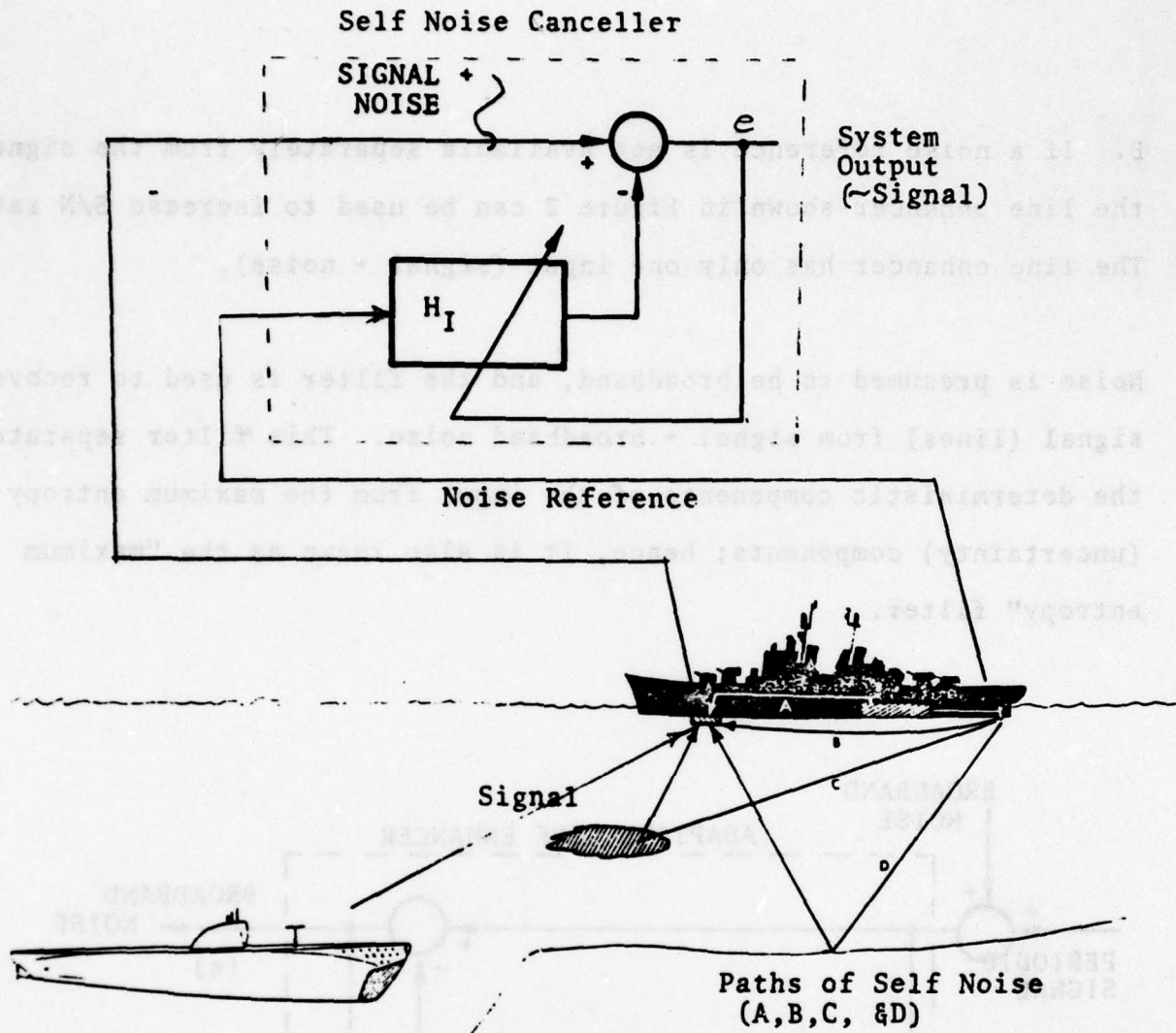

Figure 1. Application of Noise Canceller to Ship's Self-Noise Problem. Adaptive Filtering Removes Undesirable Self-Noise from the Received Acoustic Signal.

B. If a noise reference is not available separately from the signal, the line enhancer shown in Figure 2 can be used to increase S/N rate. The line enhancer has only one input (signal + noise).

Noise is presumed to be broadband, and the filter is used to recover signal (lines) from signal + broadband noise. This filter separates the deterministic components of the input from the maximum entropy (uncertainty) components; hence, it is also known as the "maximum entropy" filter.

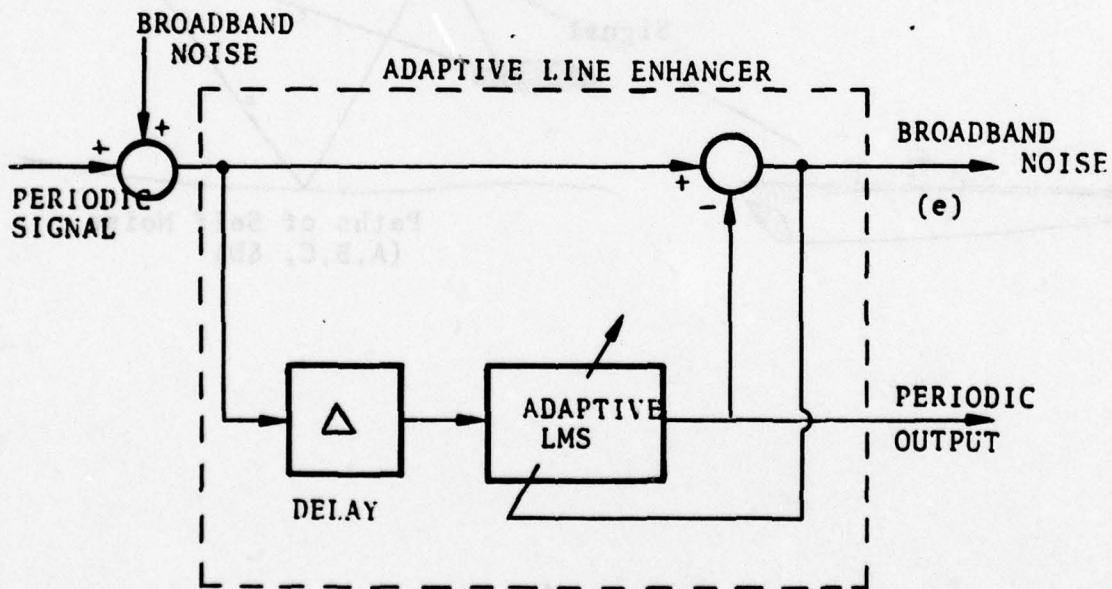

Figure 2. Adaptive Filter Used as a Self-Tuning Line Enhancer. The Periodic Output Above is the Deterministic Component of the Signal Plus Noise Input.

Example: Adaptive Noise Cancelling

Consider a primary sensor receiving a signal contaminated by noise with a reference sensor located to receive the noise alone. The output of the primary (referenced) sensor is to be filtered to obtain signal alone. Propagation paths from the noise source to the sensors must be known to design the appropriate filter. These paths are rarely known a priori, in addition they are often slowly varying. The idea of adaptive noise cancelling, as illustrated in Figure 1, is to find by adaptive means a filter capable of transforming noise at a reference sensor into noise at the primary input. The adaptive noise canceller changes reference amplitude and phase to match the amplitude and phase of the corrupting noise in the primary input signal. The filter subtracts this term from the primary input and (ideally) produces an output with none of the offending sinusoids present.

Traditionally the attempt to subtract an undesirable sinusoid was poor engineering practice since any phase or amplitude errors resulted in an increase of noise due to imperfect cancellation. The adaptive technique, however, permits near perfect noise cancellation since it tracks both phase and amplitude of the offending sinusoid.

Figure 3 illustrates the operation of single frequency noise cancellation process. The input reference sinusoid is split into two components, one of which is shifted in phase. A weighted sum of these components can achieve the required (arbitrary) amplitude and phase. Weights are

generated by the LMS algorithm to match the varying phase and amplitude of the sinusoid contained in the primary input. This technique can be extended to a large number of sinusoids as indicated by the generalized LMS algorithm shown in Figure 4.

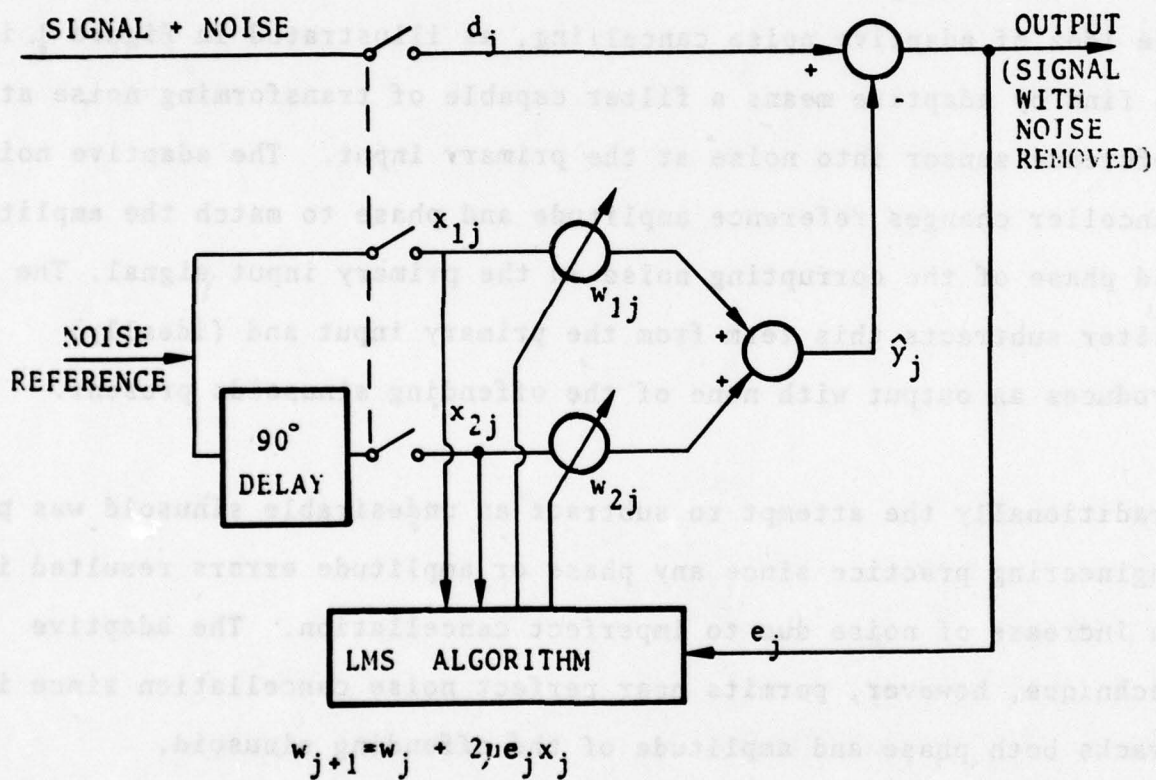

Figure 3. Single Frequency Adaptive Noise Canceller Example. The LMS (least mean square) algorithm adjusts amplitude and phase to allow cancellation of the input signal noise component. For a single frequency noise one delay and two weights are adequate to construct a sinusoid of arbitrary amplitude and phase.

Noise Cancellation as a Parameter Identification Problem

An example of an operational situation which can benefit from noise cancelling concepts is the passive search for a submerged submarine (see Figure 1). In addition to the signal (submarine sounds) the surface ship receives noise generated by its own machinery. Because this noise propagates from the machinery to the hull then through the water to the hydrophone it experiences phase and amplitude changes. These phase and amplitude changes are represented by a transfer function H . In order to subtractively cancel this noise term, an effective filter must duplicate H .

Figure 5 shows the noise corruption process and subsequent LMS filter noise cancellation. The sinusoidal noise source is represented by $1/P$; the transfer function H represents unknown changes to the noise occurring between its instrumentation. If the adaptive process can cause H_1 to be equal to H , noise cancellation is perfect. Two experiments are presented next to illustrate the LMS filter performance as an unknown system model identifier and hence motivate more efficient forms.

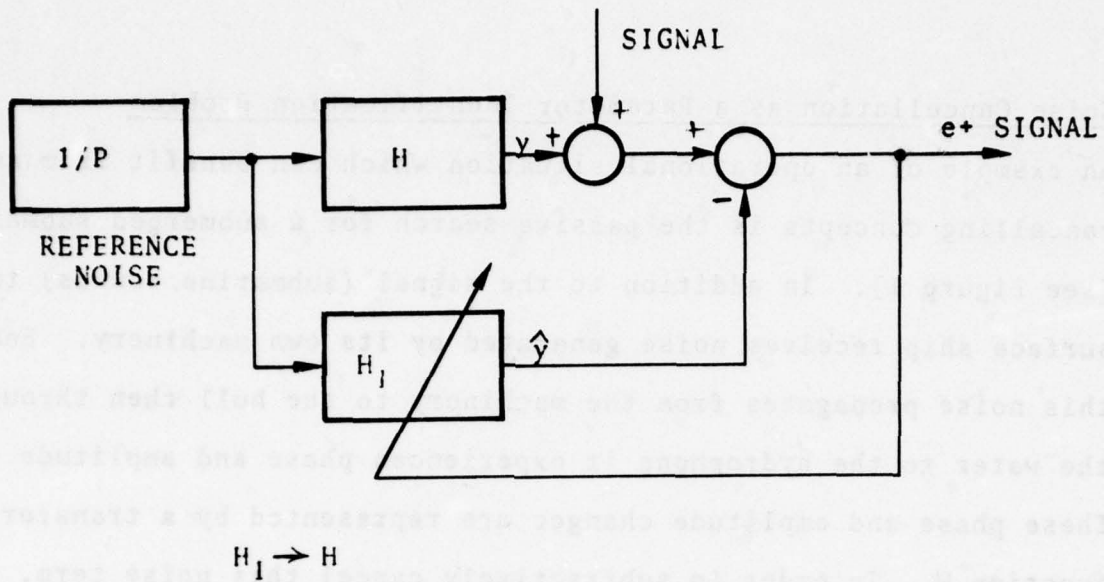

Figure 4. The Noise Canceller as a Parameter Identification Problem. In the steady state H represents the modification of noise phase and amplitude by propagation between the source and noise canceller. When H_1 , the LMS algorithm approximation of H , is exact, noise cancellation is perfect.

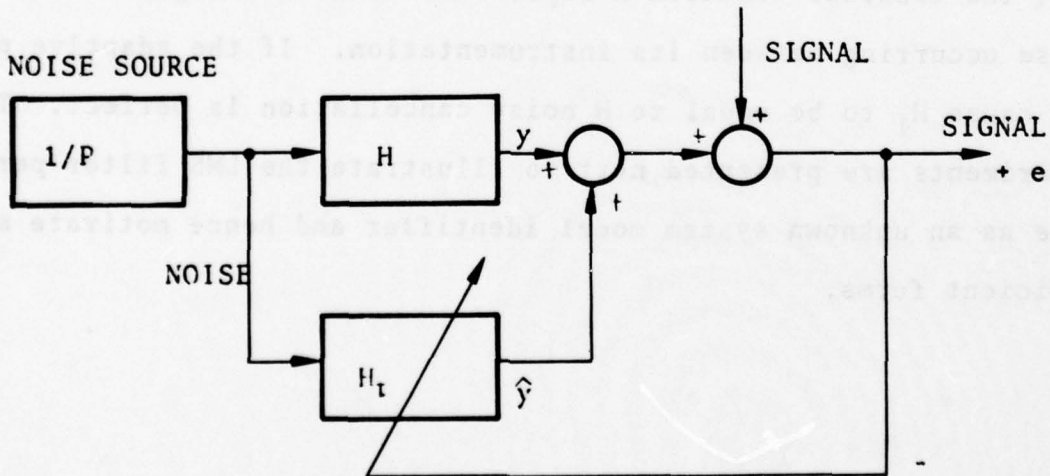

Figure 5. Modification of Figure 4 to Illustrate Noise Cancellation. When $H_1 = H$, $\hat{y} = y$ and the output of the first summing junction is zero indicating perfect noise cancellation.

Experimental Identification of a Model Containing Zeroes Only*

Assume that a signal $s(t)$ is applied to a physical system of unknown impulse response $h(t)$ and that it is possible to measure $s(t)$ and the system output $s(t)*h(t)$, where the asterisk denotes convolution. Such conditions occur, for example, when a known signal is transmitted to a receiver over a multipath propagation channel (Figure 1). The adaptive transversal (LMS) filter described in the preceding part of this report can be used to model (identify) $h(t)$ by the method shown in Figure 6. The signal $s(t)$ or a local replica of it is sampled to form the input x_j of the adaptive filter, and the output signal $s(t)*h(t)$ is sampled to form the desired response y_j . The filter output \hat{y}_j is subtracted from y_j to form the error e_j . The adaptive process minimizes the difference between y_j and \hat{y}_j to produce the model of $h(t)$. The presence of additive independent noise $n(t)$ in $s(t)*h(t)$ contributes to noise in the weight vector but does not prevent convergence in the mean.

*From reference 2.

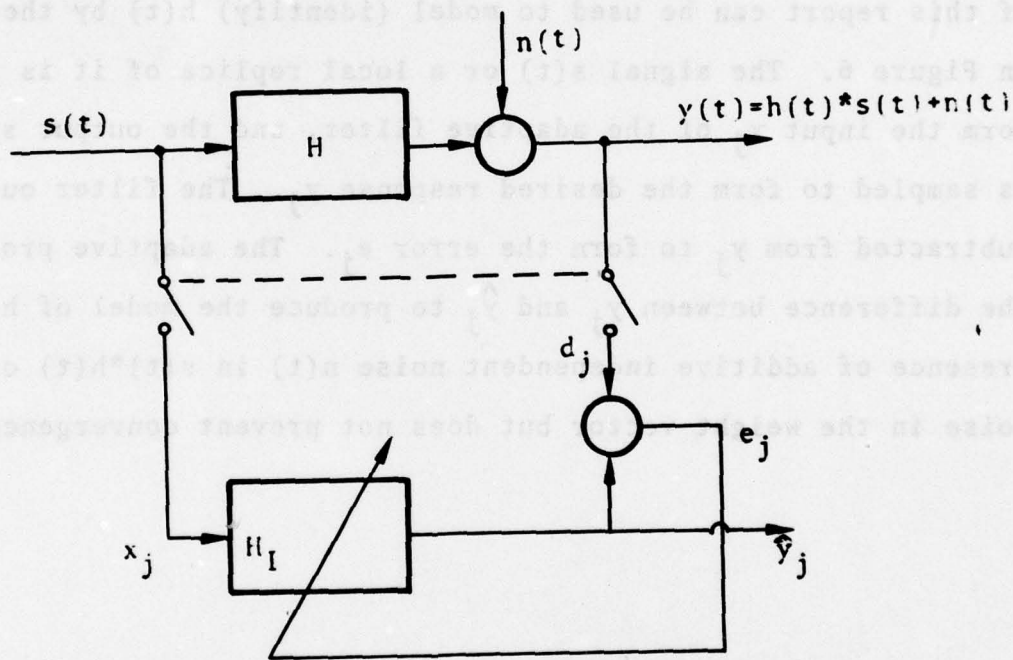
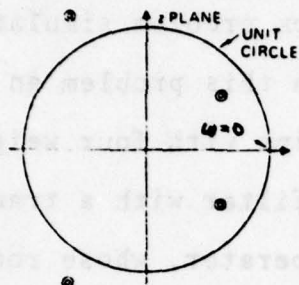

Figure 6. Example of Experimental System Model Identification Using an Adaptive Filter. The LMS algorithm approximation of H is indicated by H_I .

The results of a simple model identification problem simulated on the computer are presented in Figure 7. In this problem an adaptive transversal filter incorporating a delay line with four weighted taps was used to identify (model) a fixed filter with a transfer function $H(z)$, where z is the unit delay operator, whose roots comprised four zeros. The input signal s consisted of Gaussian noise with a "white" spectrum. Figure 7(a) shows the location in the z plane of the zeros of the fixed (unknown) filter and the "instantaneous" adaptive zeros in the absence of additive noise.¹ Note that the adaptive identification of the model is exact. Figure 7(b) shows the location of the zeros when additive independent noise was combined with the fixed (unknown) filter output in the manner indicated in Figure 6. The signal-to-noise ratio was 0 dB. In this case the zeros of the adaptive model vary their location with time even after convergence of the adaptive process and are scattered about the location of the fixed zeros. The mean location of each group of the adaptive zeros, however, is nearly the same as the location of the corresponding fixed zeros. Scattering of the adaptive zeros in this example illustrates the cause of misadjustment, noise in the weight vector.

¹In this and the succeeding experiment the zeros and poles of a time-variable filter are defined as varying coefficients in a differential equation; the filter parameters are "frozen" at any desired point in time and the zeros and poles found in the same way as for a fixed linear filter.

○ FIXED FILTER ZEROS
● ADAPTIVE FILTER ZEROS



(a)

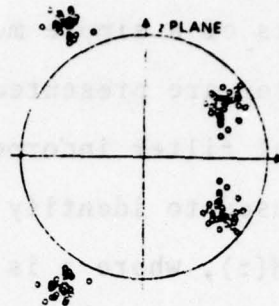

(b)

Figure 7. Results of experiment in which a 4-zero unknown filter was identified by a 4-weight adaptive filter. (a) Location of zeros after convergence without added noise in unknown system output. (b) Location of zeros after convergence with additive independent noise in unknown filter output.

+ FIXED FILTER POLES
● ADAPTIVE FILTER ZEROS

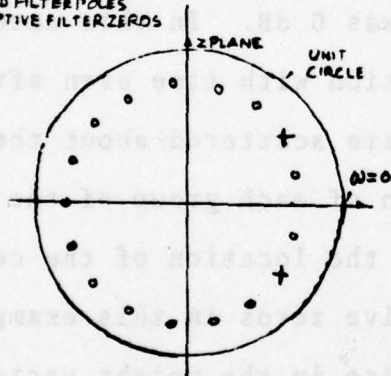

(a)

Transfer Function Magnitude

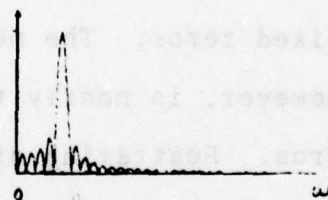

(b)

Figure 8. Results of experiment in which a 2 pole unknown filter was identified (modeled) by a 16 weight transversal filter. Note that the pole model identification by a transversal filter is accomplished by an absence of the regularly spaced zeros at the unknown pole location.

For an adaptive transversal filter to converge to an exact model of an unknown system the impulse response $h(t)$ of the system must be finite, and the filter's delay line must have a sufficient number of weighted taps to span $h(t)$. If $h(t)$ is not finite, an approximate model can be achieved though, this may require a large adaptive system.

Pole Model Parameter Identification Experiment*

Consider the result of a computer simulation in which a 16-weight adaptive transversal filter was used to model a two-pole fixed filter with an infinite impulse response is shown in Figure 8. The zeros of the adaptive model are located on a circle at a radius equal to that of the poles of the fixed filter except at frequency $\omega = 0$. Note that the spacing is uniform but that there are no zeros at the location of the poles. This solution represents the best approximation (in the mean square sense) of an all-pole transfer function by an all-zero adaptive filter. Adaptive method of uniquely determining both the poles and zeros of an unknown system is described in references 5, 6, and 7.

This last experiment in pole model identification is of special interest, since the line enhancer performance is in fact identification of the deterministic lines within noise.

*From reference 2.

III. THE LINE ENHANCER AS A SIGNAL MODEL IDENTIFIER

Consider Figure 9, the "line enhancer" or maximum entropy filter. Let the filter input of signal plus noise be generated by white noise exciting the transfer function $(1 + \frac{1}{P(s)})$. The objective of the filter is to give the deterministic lines at \hat{y} , which is equivalent to maximum uncertainty at e . Hence the transfer function H_I required to accomplish maximum entropy (Eq. (1)) is given by Equation 2.

$$(1 + \frac{1}{P(s)}) (1 - H_I) = e/w \quad (1)$$

$$H_I = \frac{1}{1+P(s)} \quad (2)$$

Hence the "line enhancer" achieves its objective by identifying the poles, or the model of the unknown signal lines. The inefficiency of the line enhancer in pole model identification is illustrated by the second experiment above, i.e., see Figure 8.

large numbers of zeros are necessary since the absence of zeros
 represents a pole. A combination of two LMS filters called the
 "recursive filter" (reference 7) can accomplish the pole location
 rather more directly. This recursive filter is indicated in
 Figure 10; it accomplishes the pole model identification by pole
 placement, not by an absence of zeros as in the line enhancer.
 As in figure 8, a pair of poles could accomplish the representation
 attempted by 10 zeros more directly. Consider the recursive filter
 indicated in Figure 10, the transfer functions H_1 and H_2 represent
 zero and pole model identifiers respectively. This can be seen in
 the transfer function equation (1).

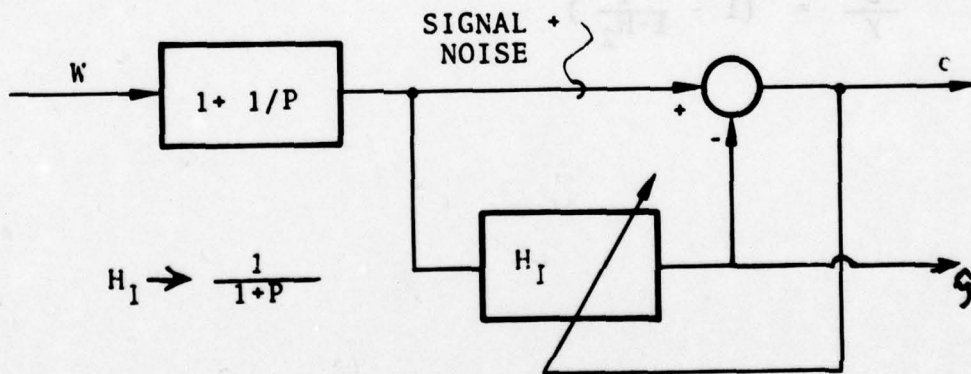

Figure 9. The Line Enhancer as a Signal Model Identification Algorithm.
 The signal e represents the random component of the signal plus noise,
 and g represents the deterministic component. DFT is usually applied
 to g to give the "enhanced" spectral lines.

Large numbers of zeroes are necessary since the absence of zeroes represents a pole. A combination of two LMS filters called the "recursive filter" (Reference 7) can accomplish the pole identification more directly. This recursive filter is indicated in Figure 10; it accomplishes the pole model identification by pole placement, not by an absence of zeroes as in the line enhancer. As in Figure 8b, a pair of poles could accomplish the representation attempted by 16 zeroes more directly. Consider the recursive filter indicated in Figure 10, the transfer functions H_1 and H_2 represent zero and pole model identifiers respectively. This can be seen in the transfer function Equation (3).

$$\frac{e}{y} = (1 - \frac{H_1}{1-H_2}) \quad (3)$$



Figure 9. The line enhancer as a signal model identifier. The signal x represents the random component of the signal with noise. H_1 represents the zero model identifier component. H_2 is usually required to give the "enhanced" spectral lines.

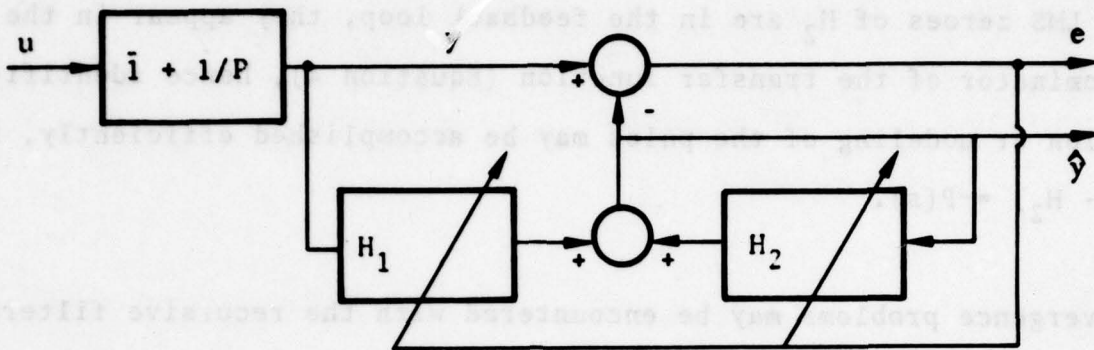

$$\frac{e}{y} = (1 - \frac{H_1}{1-H_2}) \text{ for } e = u$$

$$\text{we need } (1 - \frac{H_1}{1-H_2}) (1 + \frac{1}{P(s)}) = 1$$

Figure 10. The Recursive Filter with H_1 and H_2 representing LMS Transversal Filters. H_2 in the feedback path accomplishes pole model identification directly, not as an absence of zeroes.

Let the input signal to the filter be white noise and some deterministic spectral lines represented by $\frac{1}{P(s)}$. As for the line enhancer, the filter objective is to identify the deterministic component, or maximize the entropy of e . Hence the filter output at e must have canceled or identified the deterministic lines, as indicated by Equation (4)

$$(1 + \frac{1}{P(s)}) (1 - \frac{H_1}{1-H_2}) = \frac{e}{u} \approx 1 \quad (4)$$

The potential for efficient pole model identification exists. Since the LMS zeroes of H_2 are in the feedback loop, they appear in the denominator of the transfer function (Equation 4), hence identification or modeling of the poles may be accomplished efficiently, i.e.:

$$(1 - H_2) = -P(s).$$

Convergence problems may be encountered with the recursive filters. The form of the filter begins zero identification before poles aid in stabilizing the algorithm. The rate of convergence and the relationship of degrees of freedom necessary for good performance are questions of interest.

The preceding sections have established a connection between filtering and model identification. Unknown system model identification for adaptive control has been a topic of recent interest.^{5,6,7} Adaptive control of a system requires the identification of the slowly varying system to be controlled. The transfer of analysis methodology from the control system theory to signal processing may have synergetic benefits; for example a quantitative explanation of an observed signal processing phenomenon by observer theory is presented next.

IV. ADAPTIVE OBSERVER PARAMETER IDENTIFICATION

Consider using a parameter identification algorithm intended for adaptive control systems (Appendix A). The "Adaptive Observer Parameter Identification" AOPI algorithm is intimately related to the LMS filter above, and hence analysis methodology appears transferrable. New analysis methodology may give insight into the existing LMS filter applications and aid in the understanding of the recursive filter.

An example of the benefit of new analysis approach is developed next. Consider an observed phenomenon of line enhancer "pole-shift" due to the insertion of zeroes into the unknown signal. The pole-shift is intuitively acceptable, since the LMS filter is a constrained model identifier, and will adjust parameters to give a minimum mean square error. A quantitative description of the phenomenon is desired.

Consider the AOPI algorithm outlined in Appendix A, represented in Figure 11. A concise problem statement is as follows:

Given: A signal composed of sinusoids and white noise, with a signal to noise ratio much smaller than one ($s/n \ll 1$). Such a signal can be viewed as a Markov model output where the sinusoids are periodic random variables.¹⁰ Find the unknown model. Discussion - The algorithm requires as one of its inputs the input to the unknown system.

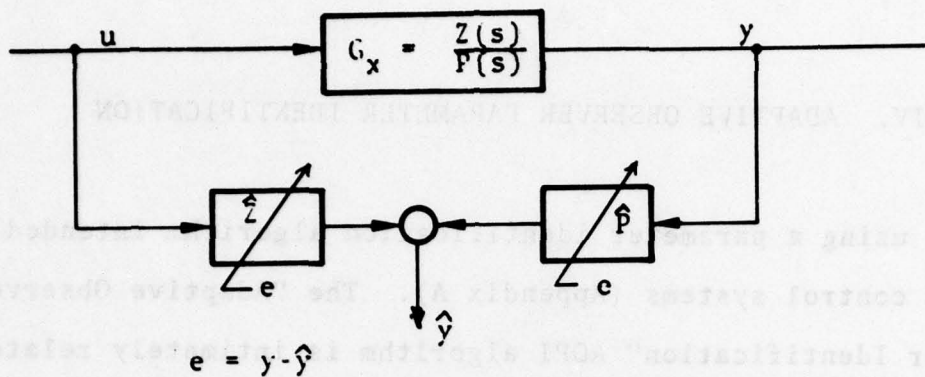

Figure 11. Adaptive Observer Parameter Identification; \hat{Z} and \hat{P} are estimates of unknown system zeroes and poles respectively. Parameter adjustment is by a LMS formulation (Appendix A).

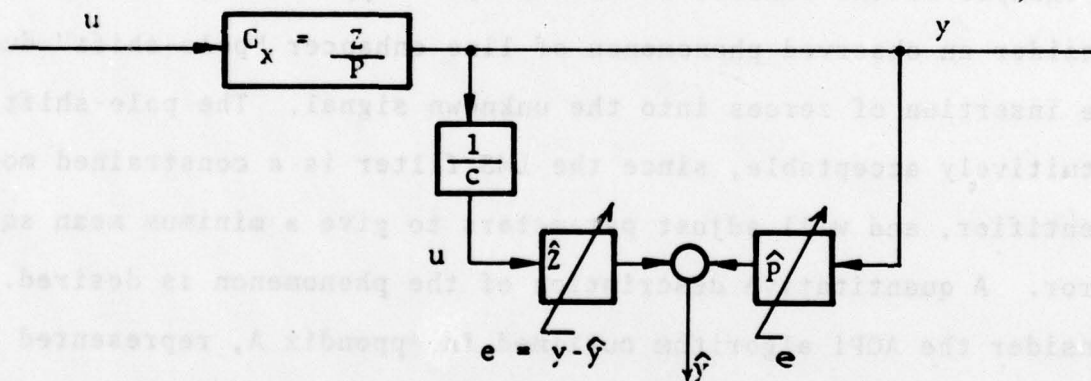

Figure 12. Modification of AOPI to conform with line enhancer condition of no isolated noise measurement. Modification is possible if $s/n \ll 1$ hence $y \approx cu$, that is, the dominant component of y is the noise exciting the unknown Markov model G_x .

This, however, is not available for the line enhancer.¹ Since we have hypothesized a signal to noise ratio much smaller than one, we can approximate the input to the Markov model as the dominant component in the output of the Markov model. Hence, we can switch the connection to the output side of the Markov model, see Figure 12. This allows a combination of the pole zero identifiers in the AOPI algorithms as indicated in Figure 5. Finally, we can merge the estimation of the poles and zeros so that we have a quantitative explanation of the apparent pole shift due to the insertion of zeros in the Markov model, see Figure 5, and Eq. 5.

$$\left(\frac{\hat{b}_i}{c} - \hat{a}_i \right) = \tilde{a}_i \rightarrow \tilde{p} \quad (5)$$

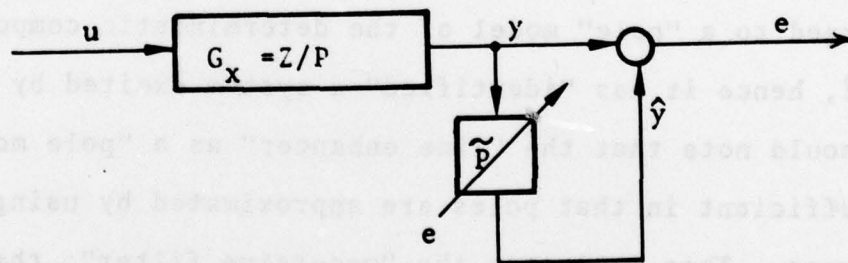

Figure 13. Constrained Form of Figure 12 to Correspond to "Line Enhancer" Conditions. The \tilde{P} represents "pole identification" transversal filter with nonuniform tapped delays and a more general state variable form than that used for Widrow's LMS filter (see Appendix A).

V. OVERVIEW

The ocean acoustics surveillance signal processing techniques require the accommodation of nonstationary signals and noise sources. Conventional analysis techniques such as the Discrete Fourier Transform (DFT) degrade³ under correlated noise and nonstationary signal conditions. Adaptive filters such as Widrow's LMS¹ filter hold promise for superior performance in the nonstationary environment. Widrow's LMS algorithm has been successfully used in a noise canceller and line enhancer mode.¹ Using the terminology of Reference 1, Widrow's LMS line enhancer can be called a "pole-model identifier" of the deterministic component of the signal.

The LMS algorithm can be considered acting as a "whitening filter"¹ to cancel periodic interference. The LMS filter has in some sense converged to a "pole" model of the deterministic component of the signal, hence it has "identified" a system excited by white noise.^{10,9} One should note that the "line enhancer" as a "pole model identifier" is inefficient in that poles are approximated by using a large number of zeroes. This motivates the "recursive filter"; that is, it would be more efficient to approximate poles by poles. The "recursive filter"⁴ used as a line enhancer may be called a "pole-zero" signal model identifier.

Widrow's LMS algorithm and the Adaptive Observer Parameter Identification (AOPI)^{5,6,7} algorithm have a great deal of similarity. Both algorithms use the same form of steepest descent parameter adjustment law. Under suitable restrictions, the AOPI algorithm contains the LMS line enhancer as a special case (see Appendix B). The AOPI analysis is concerned with the dynamics of parameter and state estimation convergence by using control theoretic models.^{5,6,7} Past LMS analysis^{1,2,4} was primarily concerned with steady state analysis using Wiener filter theory. The AOPI method has been used to identify both poles and zeros of a transfer function. The "recursive filter"⁴ is the first LMS algorithm attempt to identify a pole and zero model of a signal. It is anticipated that the AOPI approach, using a suitable state variable form, will provide new insight and explanation of the recursive filter. AOPI theory and the stability proof is in the continuous time domain. This permits separate consideration of the digitization and stability problems.⁷ One motivation for the recursive filter analysis is that with good state and parameter estimates available, the deterministic signal spectrum becomes directly available by projection operator; i.e., DFT of the LMS filter output would no longer be necessary.

Past Analysis of Preceding LMS Algorithms

Until recently, analysis of Widrow's LMS algorithm¹ has been by Wiener filter theory. Recently Harris³ has presented a unifying adaptive filter theory based on Kalman filter formulation. Harris' results contain the LMS algorithm as a special case. The "recursive filter" analysis has been attempted (heuristically) by Feintuch⁴ using Wiener filter theory. A rigorous analysis of the recursive filter is not available at this time.

Objective of Possible Analysis

The main objective of a possible effort is the analysis of the recursive filter⁴ by AOPI approach^{5,6,7}. The AOPI analysis approach differs from past methods of analysis in that (a) no Wiener or Kalman filter formulation is used, (b) parameter and state estimate convergence is considered from a Liapunov function and state observer approach, and (c) the dynamic rather than the steady state filter behavior is considered by the AOPI method. The input to the system to be identified is required to have sufficient spectral content to excite all modes of the unknown plant. Experience with the AOPI method has indicated the need for more design parameters than are currently indicated in the LMS algorithm, that is, for the LMS we have the one parameter " μ ", for the AOPI method⁷ we have $6n$ design parameters, where n is the number of states in "unknown system".

These design parameters were found to be helpful in the "efficient" digital implementation and desensitization of the identifier from input spectrum variations. For example, the LMS line enhancer is unconditionally stable if μ :

$$0 < \mu \sum_{i=1}^m \mathcal{E}\{X_i^2\} < 1$$

where the X_i are the delay line tap outputs. The flexibility of other state variable forms^{5,6,7} permits the tailoring of the algorithm to specific conditions. That is, retaining the flexibility of state variable form selection we may be able to reduce the sample rate required to identify the unknown spectrum to that required to accurately model the highest frequency in the spectrum. The form of the recursive filter⁴ is of interest, specifically the scheduling of the apparent zero identification before the pole identification (see Figure 10).

Preliminary results (Section 5) indicate that the line enhancer is a special case of the AOPI algorithm. It is anticipated that a suitable state variable form exists that will relate the "recursive filter"⁴ to the AOPI form.^{5,6,7} The "recursive filter" holds the potential for better line enhancement because general spectral line models are pole-zero models and the "recursive filter" is not constrained to zero identification only. Recall that the presently

used "line enhancer algorithm" is a constrained identifier using large number of zeros to approximate poles.

Analysis Methods and Relationships

Observer theory⁸ is a deterministic state estimation theory which is related to a steady state Kalman filter. The Wiener filter is a steady state Kalman filter. Widrow's LMS line enhancer when convergence is complete has in some sense "identified" (cancelled) the deterministic component of the signal.^{3,8} The Adaptive Observer Parameter Identification" (AOPI) method^{5,6,7} selects a specific observer gain which gives a stable state estimator, rather than one dictated by Wiener/Kalman theory. The AOPI method is using control theoretic methods to analyze the dynamics of the parameter estimation convergence. Past LMS analysis concentrates on the Wiener filter methodology which implies steady state rather than the dynamic analysis. The AOPI method does not directly relate the steady state performance to the noise/signal spectrum. Hence the proposed AOPI analysis approach does not duplicate previous work.^{1,2,3,4,9}

APPENDIX A

The Adaptive Observer Parameter Identification (AOPI) Algorithm.^{5,6,7}

Consider the problem of identifying the system dynamics from input and output signal measurement. Assume the input has sufficient spectral content to excite all the modes of the unknown system. Let G_x represent the unknown system transfer function which is a ratio of polynomials in s . The identification problem is indicated in Figure A-1. An example of state variable form selection is given by block diagram, Figure A-2, together with the unknown transfer functions.

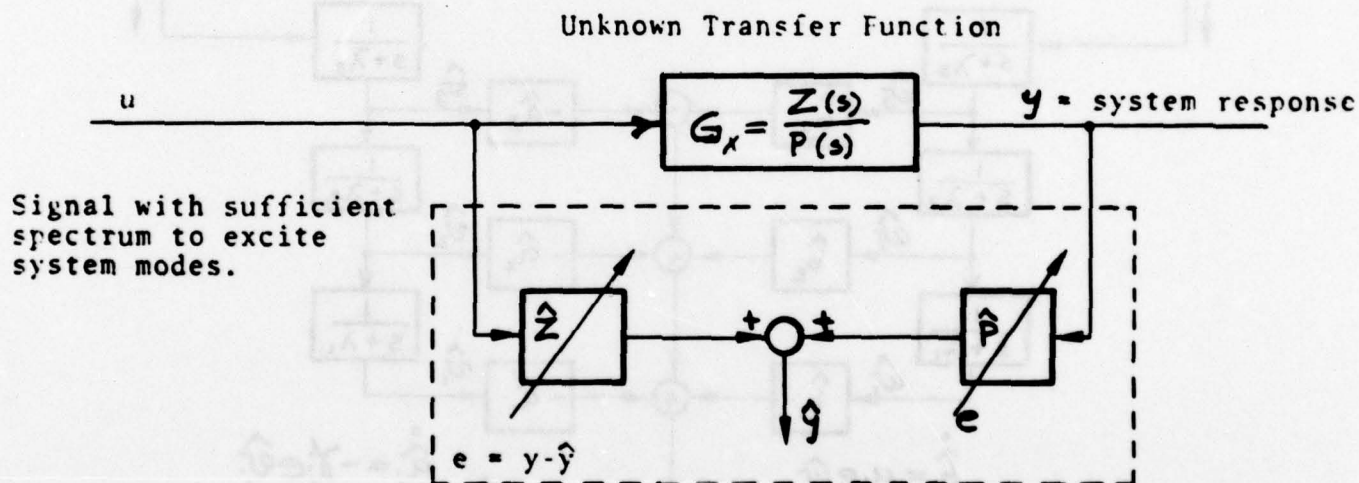

Figure A-1. Unknown System Parameter Identification by input and output measurement. The AOPI parameters \hat{Z} and \hat{P} denote estimates of Z and P respectively.

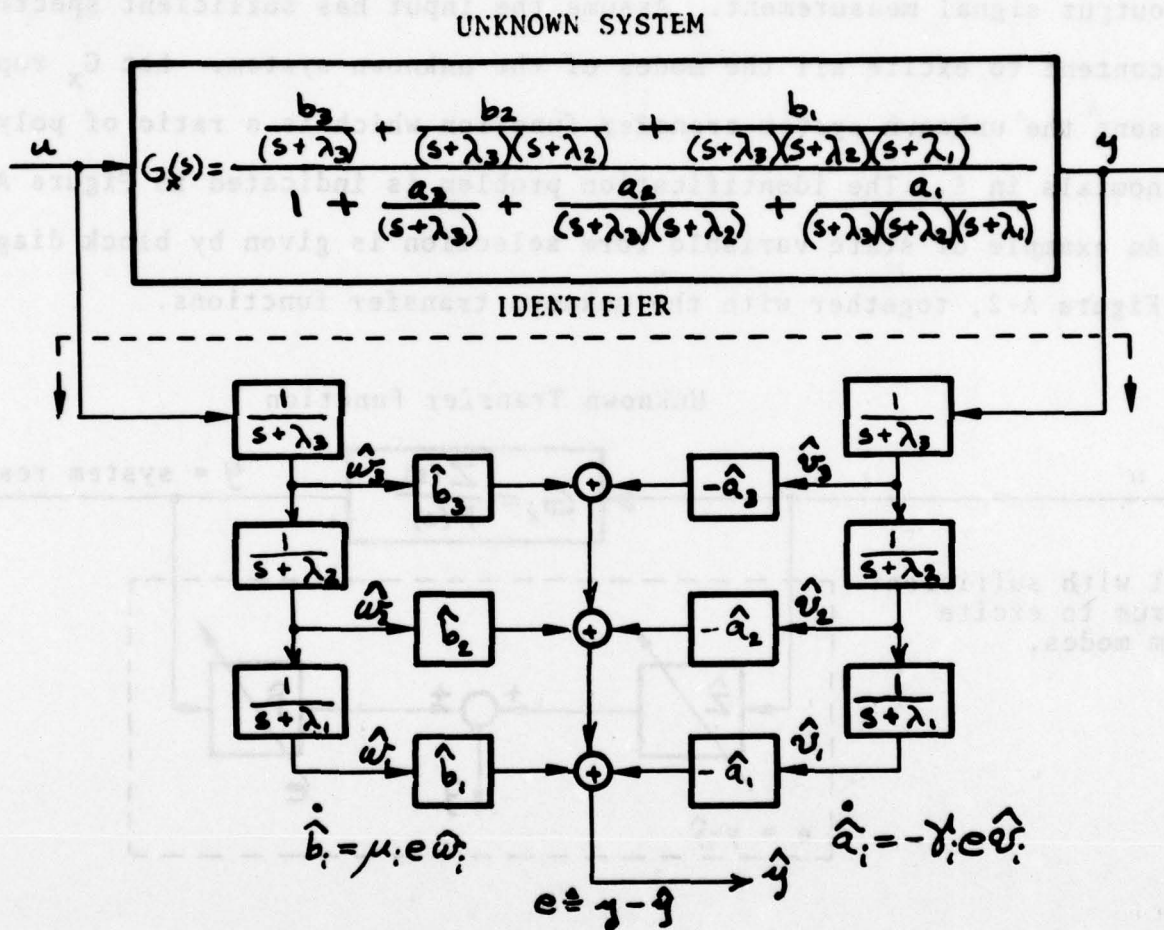

Figure A-2. Block Diagram of G_x and state variable form for relating the zero-pole parameters (a,b) in terms of known λ . Note the number of design parameters available ($\lambda_i, \mu_i, \gamma_i$) for selection.

The state variable form indicated in Figure A-2 is one of a general class of possible representations.^{5,6,7} The λ_i , μ_i , γ_i are selected for state estimate and parameter estimate convergence

$$(\hat{w}, \hat{v}, \hat{a}, \hat{b}) \rightarrow (w, v, a, b).$$

Additional parameters can be introduced⁷ to adjust total signal power level to keep the algorithm "well conditioned". A "well-conditioned" algorithm is defined here to mean one that requires the minimal integration step size to adequately reconstruct the unknown model.

The parameter updating is by LMS algorithm, integration of a function containing signal. Hence a larger than expected signal power level can cause the integration step size to be inadequate, resulting in parameter estimate divergence.

The analysis of parameter identification from the AOPI^{5,6,7} viewpoint has the following steps:

- (a) State variable filter selection, that is, the expansion of the minimal (nth) order system into a 2n-order representation. This state variable selection process requires insight, since the expansion is not a unique process, i.e., compare Figures A-2 and A-3.

- (b) Formulating error equation that contains the parameter estimate errors in a linear manner. This is equivalent to selection of an appropriate Liapunov function

For relating AOFI^{5,6,7} methods to Widrow's^{1,2,3} methodology, the covariance of the error rather than the Liapunov function should be formed, i.e.,

$$V \triangleq \mathcal{E}\{e^2\} = \mathcal{E}\{(y-\hat{y})^2\}$$

Note that the error formulation is not unique by comparing references 5,6, and 7.

- (c) The analysis of dynamic convergence is by considering the time rate of change of V (\dot{V})^{6,7}
- (d) Digitization or discrete integration problems are apparent from the integration step size necessary to handle the rate of change of errors.^{6,7}
- (d) Projection operator is selected to map states in conical minimal form. This can give the frequency and amplitude of signal lines directly; i.e., DFT for signal spectral representation is not necessary.³

As an illustration of the nonuniqueness of the state variable expanded form, compare Figure 2-A with Figure 3-A and Reference 6.

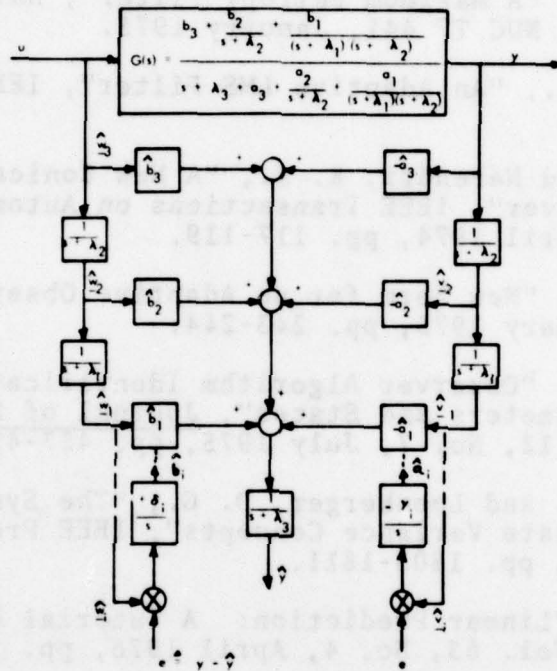

Figure 3-A. Parameter and State Estimator. The (\hat{a}, \hat{b}) are estimates of (a, b) . The $(\delta, \gamma, \lambda)$ are design parameters.

REFERENCES

1. Widrow, et. al., "Adaptive Noise Cancelling: Principles and Applications", IEEE Proceedings, Vol. 63, December 1975.
2. McCool, J. M. and Bernard Widrow, "Principles and Applications of Adaptive Filters: A Tutorial Review", (NUC In-house Publication).
3. Harris, F. J., "A Maximum Entropy Filter", Naval Undersea Center Report, NUC TP 441, January 1975.
4. Feintuch, P. L., "An Adaptive LMS Filter", IEEE Proceedings, November 1976.
5. Luders, G., and Narendra, K. S., "A New Conical Form for an Adaptive Observer", IEEE Transactions on Automatic Control, Vol. AC-19, April 1974, pp. 117-119.
6. Molnar, D. O., "New Form for an Adaptive Observer", AIAA Journal, Vol. 13, February 1975, pp. 243-244.
7. Molnar, D. O., "Observer Algorithm Identification of System Structure Parameters and States", Journal of Spacecraft and Rockets, Vol. 12, No. 7, July 1975, pp. 437-439.
8. Bryson, A. E., and Luenberger, D. G., "The Synthesis of Regulator Logic Using State Variance Concepts", IEEE Proceedings, Vol. 58, November 1970, pp. 1803-1811.
9. Makhoul, J., "Linear Prediction: A Tutorial Review", IEEE Proceedings, Vol. 63, No. 4, April 1976, pp. 561-580.
10. Molnar, D. O., and N. Walton, "A Doppler Markov Error Model Development...", NAECON 1976 Record, Dayton, Ohio, May 18, 1976, p. 28.