

AD-A069 844

PA ENGINEERING CORTE MADERA CA  
SEWAGE TRANSFER HOSE SUPPORT FACILITIES. DESIGN AND OPERATION, (U)  
APR 79 R W URBAN, J V BELLE

N00014-78-C-0524

F/6 13/2

NL

UNCLASSIFIED

1 OF 1  
AD  
A069844



END  
DATE  
FILMED  
7-79  
DDC

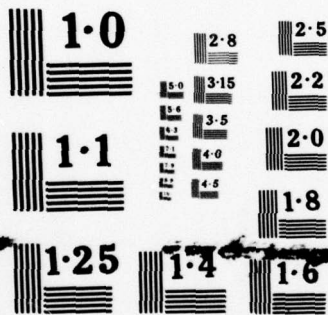

NATIONAL BUREAU OF STANDARDS  
MICROCOPY RESOLUTION TEST CHART

**A069844**

**LEVEL**

2

**SEWAGE TRANSFER HOSE  
SUPPORT FACILITIES  
DESIGN AND OPERATION**

**DDC  
RECEIVED  
JUN 13 1979  
C**

**DDC FILE COPY**

**This document has been approved  
for public release and sale; its  
distribution is unlimited.**

**APRIL 1979**

**PA Engineering**  
PROFESSIONAL ENGINEERS

SAN FRANCISCO

NORFOLK

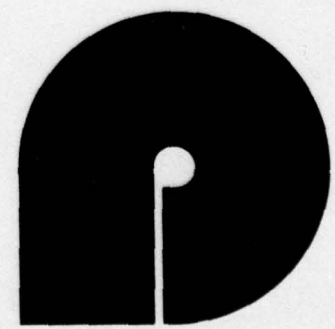

79 04 26 396

Per. Mis Zrosulis

QNR - code 232

B 18 Jun 79

6 SEWAGE TRANSFER HOSE  
SUPPORT FACILITIES  
DESIGN AND OPERATION

by  
10 R.W. Urban  
J.V. Belle

12 60 p.

11 10 April 1979

15 CONTRACT NUMBER: N00014-78-C-0524

PROJECT OFFICER:  
Scientific Officer (Code 232)  
Office of Naval Research  
800 N. Quincy Street  
Arlington, Virginia  
22217

411 174  
~~use 411 774~~

PA ENGINEERING

SAN FRANCISCO  
(415) 924-8587

PHILADELPHIA  
(215) 985-9591

NORFOLK  
(804) 625-5534

JOB

ABSTRACT

EXECUTIVE SUMMARY

By	on file Per the
Distribution	
Availability	
Dist	or
	Special

The transfer of sewage from Navy ships, submarines and small craft to shoreside treatment facilities is accomplished in all cases through the use of sewage transfer hose. At most activities, shoreside commands are responsible for the support of this sewage transfer hose and related equipment. This report examines the need for hose support facilities and presents design guidance for development of these facilities.

To support sewage transport hose, several functions must be considered. These functions include hose cleaning, hose and fitting maintenance, hose and equipment storage, and personnel facilities. This report discusses hose cleaning requirements from the stand point of operational and sanitary requirements.

At even the largest activities, hose cleaning by shoreside crews will be an infrequent activity. In most cases, direct salt or fresh water flushing of sewage transfer hoses provides an acceptable level of cleaning, and no further physical or chemical cleaning is usually necessary except for excessive solids or grease buildup. Since most shipboard sewage transfer systems are equipped with direct saltwater flushing of the sewage hose, almost all hose cleaning is accomplished prior to disconnecting from the vessel. As a result, at even the largest Naval activity with surface ships, it has been estimated that no more than about six lengths of sewage hose would require shoreside flushing each week. Of these, it is projected that three lengths may require cleaning beyond flushing each month. Frequencies for other sizes of activities are developed in the report. Because of these low frequencies, hose support facilities can be provided by adapting existing facilities or with a minimum of new construction.

The report develops examples of minimum facility designs for several activity sizes and locations. Included in Appendix A is a design check list to evaluate an activity's requirements to help develop hose support facility designs.

TABLE OF CONTENTS

	<u>Page</u>
EXECUTIVE SUMMARY.. .. .	ii
LIST OF FIGURES .. .	v
LIST OF TABLES .. .	v
1. INTRODUCTION.....	1
1.1 Statement of problem.....	1
1.2 Background .....	2
1.3 Conditions Requiring Shoreside Hose Cleaning.....	3
2. HOSE CLEANING REQUIREMENTS .....	5
2.1 Bureau of Medicine and Surgery (BUMED) Require- ments.....	5
2.2 Frequency and Quantity of Sewage Hose Cleaning...	7
2.3 Hose Cleaning Procedures .....	9
2.3.1 Shoreside Hose Flushing.....	12
2.3.2 Steam Cleaning.....	12
2.3.3 Chemical Cleaning.....	15
2.4 Cold Weather Cleaning .....	15
2.5 Small Craft .....	18
3. FACILITY REQUIREMENTS.....	21
3.1 BUMED Requirements.....	21
3.2 Operational Requirements.....	23
4. MINIMUM FACILITY DESIGNS .....	25
4.1 Large Warm Weather Facility.....	25
4.2 Small Warm Weather Facility.....	28
4.3 Large Cold Weather Facility.....	29
4.4 Small Cold Weather Facility.....	31

TABLE OF CONTENTS (Continued)

	<u>Page</u>
5. CONCLUSIONS .....	33
5.1 Hose Cleaning Frequency.....	33
5.2 BUMED Requirements.....	33
5.3 Local Initiative.....	33
5.4 Consolidation of Hose Cleaning Functions.....	34
6. RECOMMENDATIONS .....	35
6.1 NAVFAC Guidance Update.....	35
6.2 Engineering Field Division Support.....	35
6.3 Regional Consolidation of Hose Support Activity.....	35
6.4 Local Area SOPA Instructions.....	36
6.5 Ship and Shore Working Relations.....	36

APPENDIX

A. Hose Support Facility Design Check List.....	A-1
B. Sewage Hose Adapters and Fittings for Local Fabrication..	B-1

LIST OF FIGURES

	<u>Page</u>
1. Hose Cleaning Flow Chart (Surface Vessels) .....	10
2. Hose Cleaning Flow Chart (Submarines) .....	11
3. Three-inch Diesel Pump (P0201).....	13
4. P-250 Pump.....	14
5. Steam Degreasing Setup .....	16
6. Chemical Cleaning Setup .....	17

LIST OF TABLES

1. TYPICAL SEWAGE HOSE CLEANING FREQUENCY.....	8
2. WARM WEATHER FACILITY SIMPLIFIED DESIGNS.....	26
3. COLD WEATHER FACILITY SIMPLIFIED DESIGNS.....	27

## 1. INTRODUCTION

### 1.1 Statement of Problem

The requirements for facilities for supporting sewage transfer hose have not been clearly defined for MILCON pier sewer projects. Several points of view concerning the design of these facilities existed during the initial design and construction of pier sewer systems and support facilities. Field experience in ship to shore sewage transfer operations has provided valuable information on the practical requirements for facilities to clean and maintain sewage transfer hose.

Facilities have already been constructed at most major Navy ports. Some of these existing facilities have not yet been used because the original designs do not fit the user's operating needs, or the shore sewer systems have not been activated to date.

Shipboard sewage transfer systems have been fitted with direct saltwater flushing capability. Water flushing of sewage transfer hose provides a sufficient level of cleaning to the interior of the hose, and disinfection of the hose is not required. Hose cleaning by water flushing, in most cases, is sufficient to prevent a health hazard to shipboard or shoreside hose handling personnel.

Experience during the last two years has shown that direct shipside flushing provides almost all of the required sewage transfer hose cleaning prior to disconnecting. The number of hoses that require additional cleaning is quite small. As a result, many of the facilities originally constructed for hose cleaning and disinfection may not be fully utilized.

Recommendations for hose cleaning and maintenance facility designs can now be made to fit the needs of various sizes of activities. This report will develop simplified design recommendations for four types of facilities.

These are developed in Chapter 4 as follows:

Large warm weather facility . . . . .	4.1
Small warm weather facility . . . . .	4.2
Large cold weather facility . . . . .	4.3
Small cold weather facility . . . . .	4.4

For all but the largest activities, hose cleaning facilities can be provided with a minimum of construction and in most cases using existing facilities.

## 1.2 Background

Most problems in the operation of ship to shore sewage transfer systems are the direct result of the general unpopularity of having to pump sewage into sewers rather than over the side, or an overreaction to the hazards of working with sewage handling equipment. The engineering community has had a long history of experience in handling and treating sewage. As a result, health precautions are well documented and understood.

The Navy's response to collect sewage from its vessels has relied primarily on ship or submarine Collection, Holding and Transfer (CHT) systems to pump sewage into sewers installed on piers of most Navy activities. The last and critical link in sewage transfer operations is the sewage transfer hose. The hose provides the final flexible connection to the pier sewer. The hose is also that part of the system which requires the most frequent handling by shore or shipside personnel.

During 1971 and 1972 a need was determined for hose cleaning facilities to be part of pier sewer construction projects. Early installations were designed to meet hose disinfection requirements. A determination was made in 1973, however, that no hose disinfection was required, and that sufficient cleaning could be achieved with salt or fresh water flushing.

This change in requirements provided a more practical approach to the cleaning of hose. However, the change was not clearly understood by many designers for its effect of greatly reducing the work level and frequency of hose cleaning. Many facilities were still constructed from the point of view of the earlier requirements and the designs varied from activity to activity.

Many of the designs of these facilities provided for hose maintenance and storage. Also, adjoining facilities were provided for personnel. Many of these designs were developed without understanding what was needed and in some cases violated sanitary engineering practice and common sense.

NAVFAC Ship-to-Shore Hose Handling Operations Manual M0-340 was developed from field testing in San Diego. This manual provides extensive guidance in hose handling operations, including hose cleaning and maintenance. The manual details procedures for additional hose cleaning using chlorine soaking. The recommendation for chlorine cleaning of hose has confused many facility designers into thinking that hose cleaning facilities are intended to provide for the disinfection of all sewage transfer hose. The use of chlorine in cleaning sewage hose was intended to help reduce odor and grease build-up in excessively dirty hose for those few instances when additional cleaning, beyond shipboard flushing, was necessary.

### 1.3 Conditions Requiring Shoreside Hose Cleaning

One area of confusion, particularly for those who have not handled sewage transfer hose, is how to determine when additional hose cleaning is necessary. Field experience has shown additional cleaning may be necessary for the following reasons:

1. Pier side crews may receive disconnected sewage hose which has not been adequately flushed, or has not been flushed at all. This may be the result of the ship's crew inattention to the flushing requirement, or from an improperly designed shipboard CHT system which does not yet have direct salt water flushing capability. ShipAlts to provide direct salt water flushing are still being installed and the lack of this fitting does not preclude system certification and operation. Inadequate hose flushing may be the result, particularly with the collapsible sewage hose, of hose kinking which does not permit full flushing from the salt water firemain.
2. The build-up of grease from galley wastes in sewage hoses, particularly in semi-permanent connections such as submarine or destroyer tenders, may not be adequately flushed before disconnecting.

3. Submarine sewage transfer systems do not have saltwater hose flushing provisions. The hose handling manual MO-340 recommends that the shoreside crews flush the 2½ inch sewage transfer hose from the pier immediately after disconnecting.

## 2. HOSE CLEANING REQUIREMENTS

### 2.1 Bureau of Medicine and Surgery (BUMED) Requirements

The principle objectives of BUMED in assuring proper handling, cleaning, maintenance and storage of sewage transfer hose, as with any operation with sewage, is the protection of worker health and the prevention and spread of disease. The types of diseases which can be present in human sewage include infectious hepatitis, bacillary and amebic dysenteries, typhoid and paratyphoid fevers. The prevention of these diseases is also the concern of designers and operators of sewage handling equipment. Because of the application of well-known sanitary engineering practices the occurrence of these diseases is very infrequent. However, the potential always exists. With reasonable care and common sense, health hazards from sewage can be adequately controlled.

The BUMED requirements for hose handling operations are based on the understanding of a typical hose handling sequence and the development of reasonable procedures and precautions. In a typical operation the shoreside crew passes the sewage transfer hose to the ship hose handling crew, where it is connected to the ship deck riser. The shore crew makes a similar connection to the pier riser and sewage transfer operations can begin. Prior to disconnecting, the hose is flushed for at least 10 minutes by the ship's fire-main cross connection. The hose is then drained, capped and lowered to the pier.

In understanding this sequence of operations there are two major areas where cleanliness precautions should occur to prevent direct contact with raw sewage. These are:

#### 1. Personnel

All personnel whether shoreside or shipside must wear proper clothing. This includes, aside from normal safety equipment, coveralls and

rubber gloves. The most important precaution for these workers is to prevent the ingestion of bacteria which may be on the equipment surfaces. This is most easily prevented by the requirement and the practice that they not eat, drink or smoke until after washing hands and face.

## 2. Equipment and Procedures

All connections of the hose must be leak-free, buckets or catch basins are to be placed under fittings during disconnecting. A 10-minute salt water flush of the hose before disconnecting is provided by the ship and the hose properly drained and capped.

By flushing the sewage hose prior to disconnecting, the hose will normally be adequately cleaned and ready for reuse. If the shipboard flushing is inadequate or unavailable, as in the case of submarines, the hose flushing operation can be performed shoreside. If after shoreside flushing, odors or grease persist, additional physical or chemical cleaning is recommended.

Precautions to be followed during hose cleaning operations are:

1. The discharge should be directed into a sanitary drain.
2. If fresh rather than salt water is used for hose flushing, the water source must be protected by an approved backflow preventer. No connection whatsoever shall be made to shoreside potable water hydrants or pier risers which service ships as a supply of potable water even if these risers have backflow preventors.
3. Hose cleaning operations shall not take place within close proximity to potable water hose cleaning, food handling or similar activities.

BUMED has made recommendations for the design of hose cleaning and maintenance facilities. These will be discussed in the following chapter.

It can be seen in examining the BUMED requirements for hose cleaning, that they allow for considerable local initiative as to how it is accomplished. BUMED strongly recommends a close coordination with the local Navy Environmental Preventive Medicine Unit or Naval Regional Medical Center Preventive Medicine Service, where appropriate, to advise in the preparation and operation of local facilities.

## 2.2 Frequency and Quantity of Sewage Hose Cleaning

The design and operation of hose cleaning facilities has been simplified not only by the BUMED requirements but by the significantly reduced number of hose cleanings that are necessary using these procedures. In understanding the scope of hose cleaning operations it will be very useful to develop some numerical estimates for the frequency of hose cleaning operations for various activities. In looking at these frequencies, it can be seen how relatively small a problem hose cleaning is for even the largest activity.

Table 1 develops hose cleaning frequencies for a variety of situations at large and small activities. The percentages developed in this table are the result of field experience at Naval Station, San Diego and are stated conservatively high from the opinions of the field operators.

When ship to shore sewage transfer systems are fully operational by 1981, it could be expected that at a large activity 20 surface ship departures and subsequent hose disconnects may occur per week. Assuming an average of three 50 foot standard lengths of 4 inch hose per disconnect, 60 lengths of sewage transfer hose will be disconnected per week. Since most surface vessels have direct flushing capability, most hose cleaning will be performed prior to disconnecting. If as much as 10 percent of these hoses required additional cleaning, 6 lengths of hose would need cleaning by the shoreside crews each week.

The first step in cleaning hose at shoreside is additional direct flushing. Beyond this cleaning, if 10 percent needed further cleaning (1% of total disconnected hose) this would result in 2 or 3 hoses per month which may require detergent, steam or chlorine soaking to provide the additional cleaning.

Activities with surface vessels would have very infrequent need of facilities for hose cleaning beyond direct or saltwater flushing. It would seem difficult to justify construction expenditures for facilities dedicated solely to these additional cleaning operations. In most every case, the majority of shoreside cleaning can be accomplished through the use of a saltwater hydrant, backflow protected freshwater hydrant or portable high-volume pump.

Table 1 also shows frequency cleaning estimates for a large submarine facility. This case, typically Point Loma, San Diego, may see as many as 7

TABLE 1. TYPICAL SEWAGE HOSE CLEANING FREQUENCY

Activity Size	Vessels	Weekly Departures	Avg. No. Hoses Per Vessel	Hoses Disconnected Per Week (a)	Hoses Needing Shore Cleaning (Flushing) (b)	Hoses Needing Additional Cleaning (Steam-Chemical) (c)
Large	Surface Ships	20	3	60	@ 10% of (a) 6/week	@ 1% of (a) 2-3/month
Small	Surface Ships	1	3	3	1/month	1/year
Large	Submarines	7	6	42	@100% of (a) 42/week	@ 1% of (a) 2/month
Small	Submarines	1	6	6	6/week	3/year

∞

departures and subsequent hose disconnects per week. Assuming an average of six 50 foot lengths of 2½-inch sewage transfer hose per submarine, the total number of hoses disconnected per week would be 42. Since most submarine systems cannot flush sewage hose prior to disconnect, 100 percent of all hoses disconnected will require pier flushing. If we assume that flushing of submarine hoses is as effective as it is for surface vessel hoses, then 1 percent of all hoses will require cleaning beyond shoreside flushing. This would mean that this submarine activity would have only 2 hoses per month which required additional cleaning effort.

The resulting low frequency of sewage hose cleaning operation gives the facility designer considerable latitude. The use of portable equipment, regionalized hose cleaning facilities or the postponing of hose cleaning in cold weather are all practical options.

Figure 1 shows the sequence of hose cleaning operations for surface vessels and the relative frequency of each method. Figure 2 shows a similar sequence for submarines.

### 2.3 Hose Cleaning Procedures

As previously discussed, almost all hose cleaning can be accomplished through direct water flushing from either flushing cross-connections on shipboard CHT systems or similar flushing from shoreside. After this flushing occurs, any additional cleaning is at the discretion of the shoreside personnel.

The following sections discuss the cleaning alternatives available. The determination of the need for additional hose cleaning is mostly subjective. In most cases where shipside flushing has been inadequate the hose will show visible solids, grease and have a readily offensive odor. The need for additional cleaning beyond flushing will be determined only if a strong persistent odor or visible grease and dirt remains. Clean sewage hoses will have some odor but it should not become offensive as long as adequate ventilation is available.

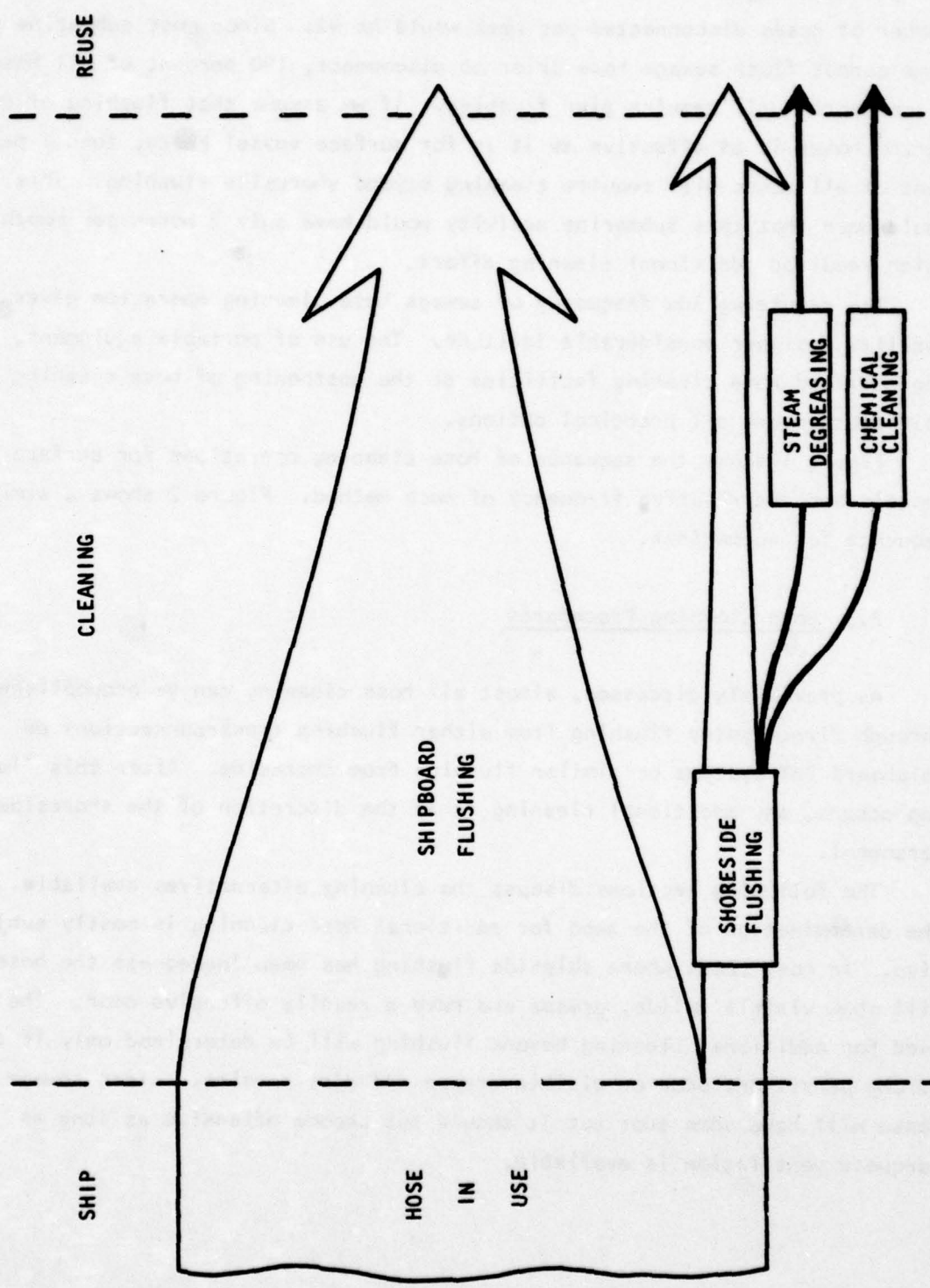

Figure 1. Hose Cleaning Flow Chart (Surface Vessels)

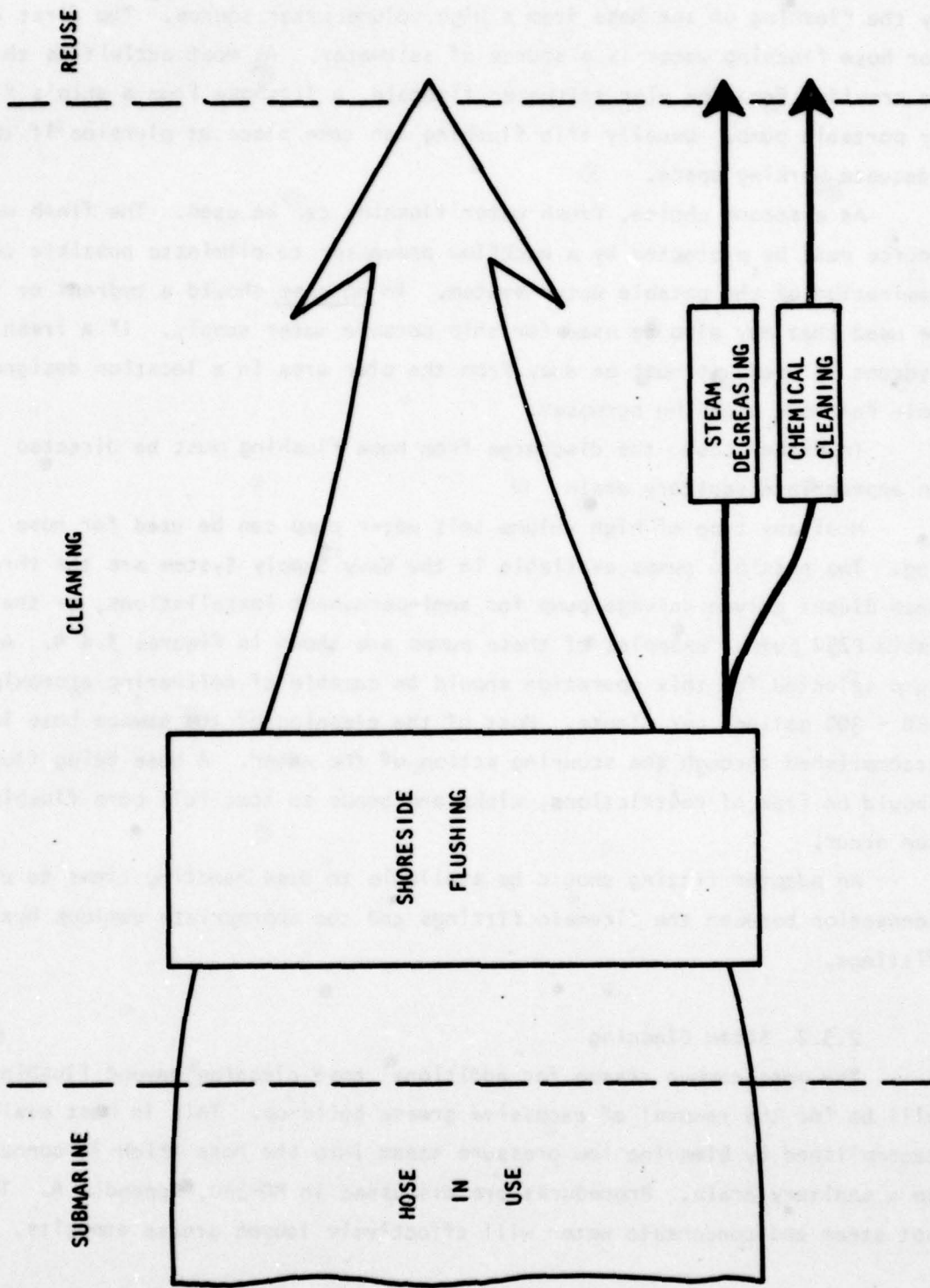

Figure 2. Hose Cleaning Flow Chart (Submarines)

### 2.3.1 Shoreside Hose Flushing

The majority of shoreside hose cleaning operations will be accomplished by the flushing of the hose from a high volume water source. The first choice for hose flushing water is a source of saltwater. At most activities this can be provided from the pier saltwater firemain, a firehose from a ship's firemain or portable pump. Usually this flushing can take place at pierside if there is adequate working space.

As a second choice, fresh water flushing can be used. The fresh water source must be protected by a backflow preventer to eliminate possible contamination of the potable water system. In no case should a hydrant or riser be used that may also be used for ship potable water supply. If a fresh water hydrant is used, it must be away from the pier area in a location designated only for hose cleaning purposes.

In either case, the discharge from hose flushing must be directed into an appropriate sanitary drain.

Most any type of high volume salt water pump can be used for hose flushing. Two possible pumps available in the Navy Supply System are the three-inch diesel driven salvage pump for semi-permanent installations, or the portable P250 pump. Examples of these pumps are shown in figures 3 & 4. Any pump selected for this operation should be capable of delivering approximately 150 - 300 gallons per minute. Most of the cleaning of the sewage hose is accomplished through the scouring action of the water. A hose being flushed should be free of restrictions, kinks and bends so that full bore flushing can occur.

An adapter fitting should be available to hose handling crews to provide connection between the firemain fittings and the appropriate camlock hose fittings.

### 2.3.2 Steam Cleaning

The most common reason for additional hose cleaning beyond flushing will be for the removal of excessive grease build-up. This is most easily accomplished by bleeding low pressure steam into the hose which is connected to a sanitary drain. Procedures are discussed in M0-340, Appendix A. The hot steam and condensate water will effectively loosen grease deposits.

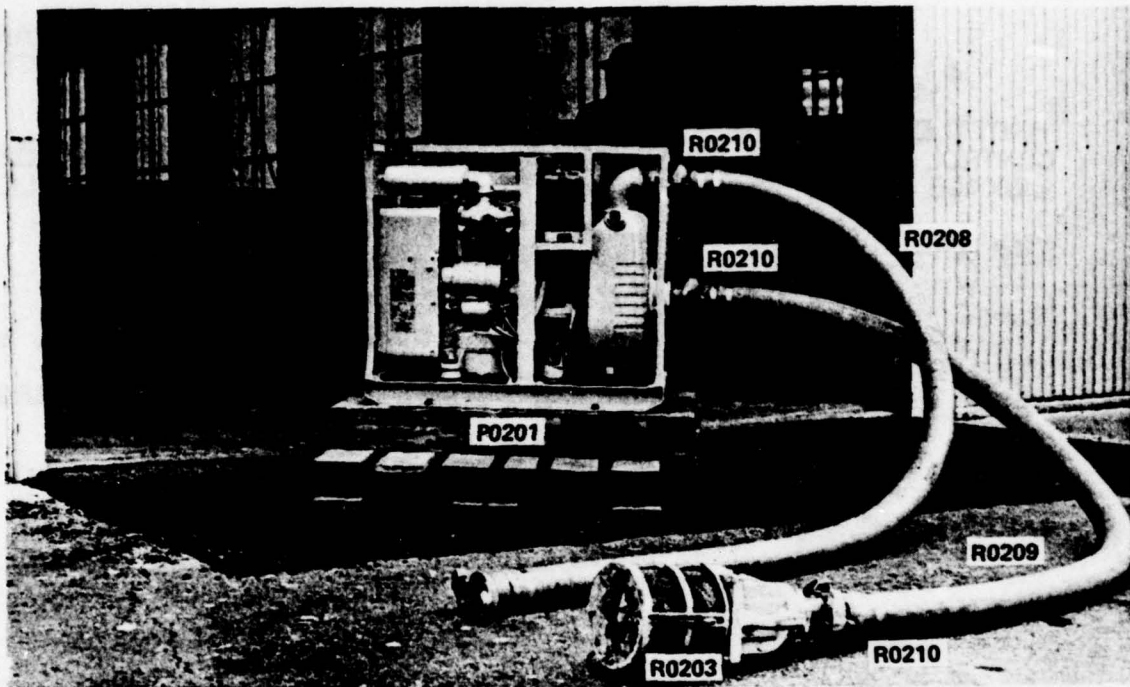

### 3-INCH DIESEL PUMP

Model	NS21CCD
NSN	2H4320-00-125-435
Output	350 gpm @ 40' head
Weight	670 lbs.

Figure 3. Three-inch Diesel Pump (P0201)

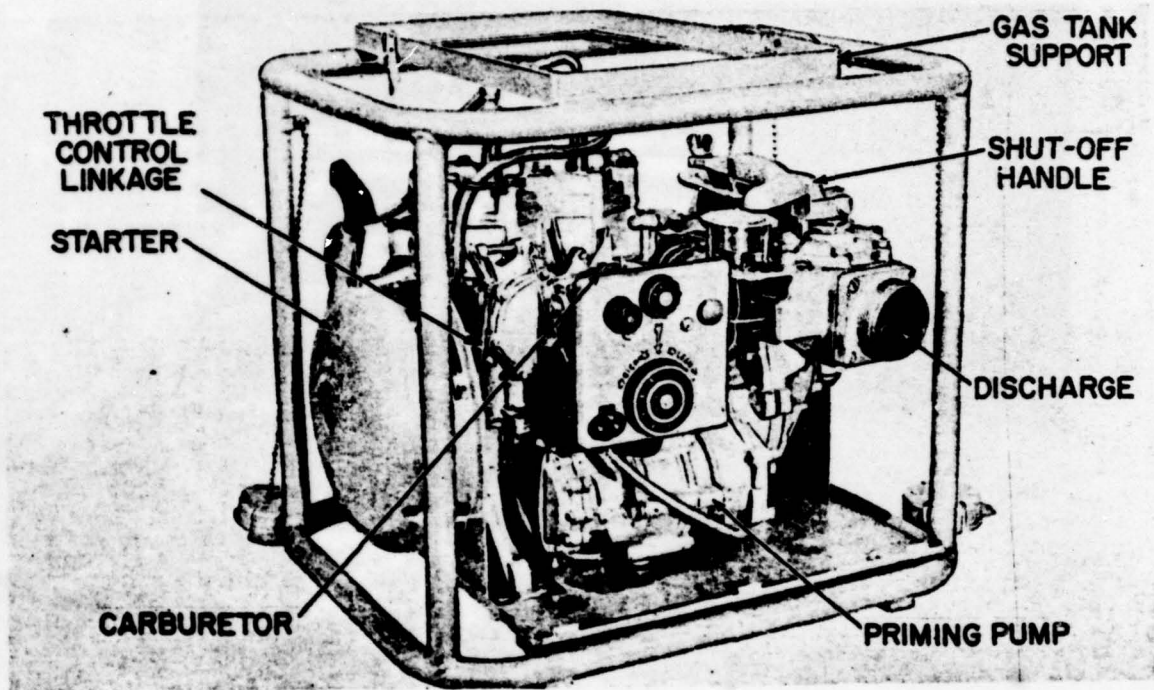

P-250 GASOLINE PUMP

Model	P-250
NSN	2H4320-00-232-6894
Output	250 gpm @ 100 psi
Weight	147 lbs. (less tank)

Figure 4. P-250 Pump

After the application of steam for approximately 10 minutes, the hose should be flushed again with water.

A special fitting to adapt the steam connection to the appropriate cam-lock should be fabricated locally as shown in Figure 5.

Any source of low pressure steam can be used and need not be located at a designated cleaning facility. Steam risers on piers or in other areas, in close proximity to sanitary drains, can be used. Normal safety precautions when working with live steam must be observed.

### 2.3.3 Chemical Cleaning

The chemical cleaning of sewage transfer hose is used primarily to remove offensive odors. This cleaning may be desirable in extreme situations where the hose may be stored for long periods, transported to another activity or provided to a tender which may be deploying for overseas operations.

Appendix A of the hose handling manual M0-340 describes the procedures for chemical cleaning using dry chlorine. Basically, the procedures call for a 20 minute chlorine soak and residual check with indicator paper.

Some activities do not allow the discharging of chlorine into sanitary drains. As an alternative, a stock detergent can be used. A final flushing of the hose with water should follow any chemical cleaning operation. As in all cleaning, the hoses should be drained and allowed to air dry before storage. Figure 6 shows a simple chemical cleaning equipment setup.

It must be stressed that the frequency of shoreside hose cleaning tasks depends on the cooperation received from shipboard sewage system operators in providing the primary hose flushing. Shipboard operators must be made fully aware of their responsibilities and encouraged to perform the hose cleaning function. Direct shore personnel contact with the shipboard personnel is often the best way to solicit cooperation and insure smooth coordination of all hose handling procedures.

### 2.4 Cold Weather Hose Cleaning

The cleaning of sewage hose in cold weather presents special problems. The hose becomes inflexible in extreme cold weather and is difficult to handle.

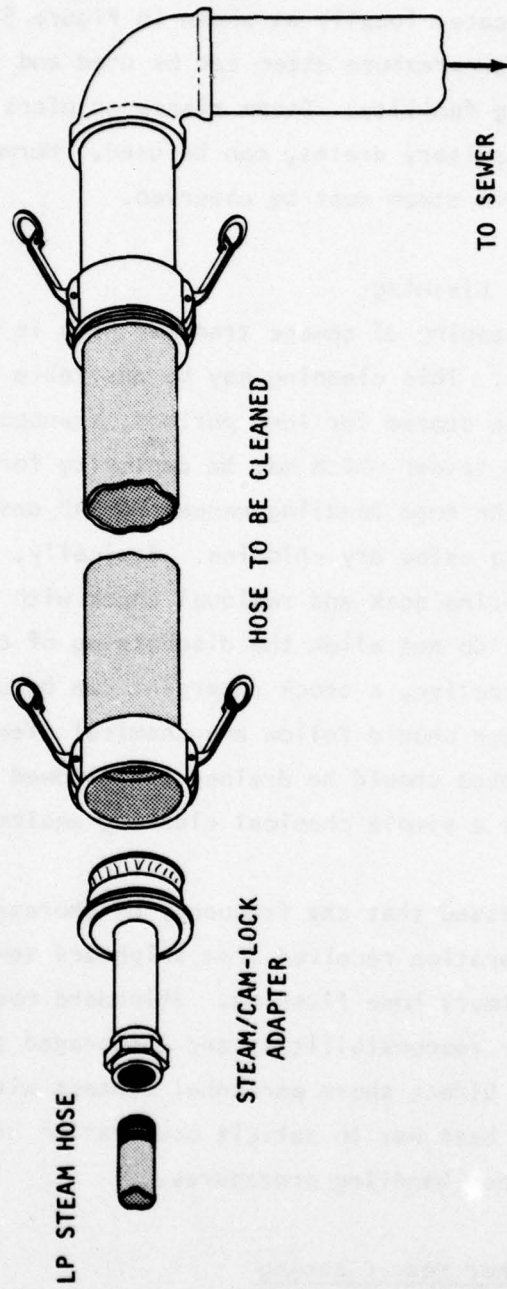

Figure 5. Steam Degreasing Setup

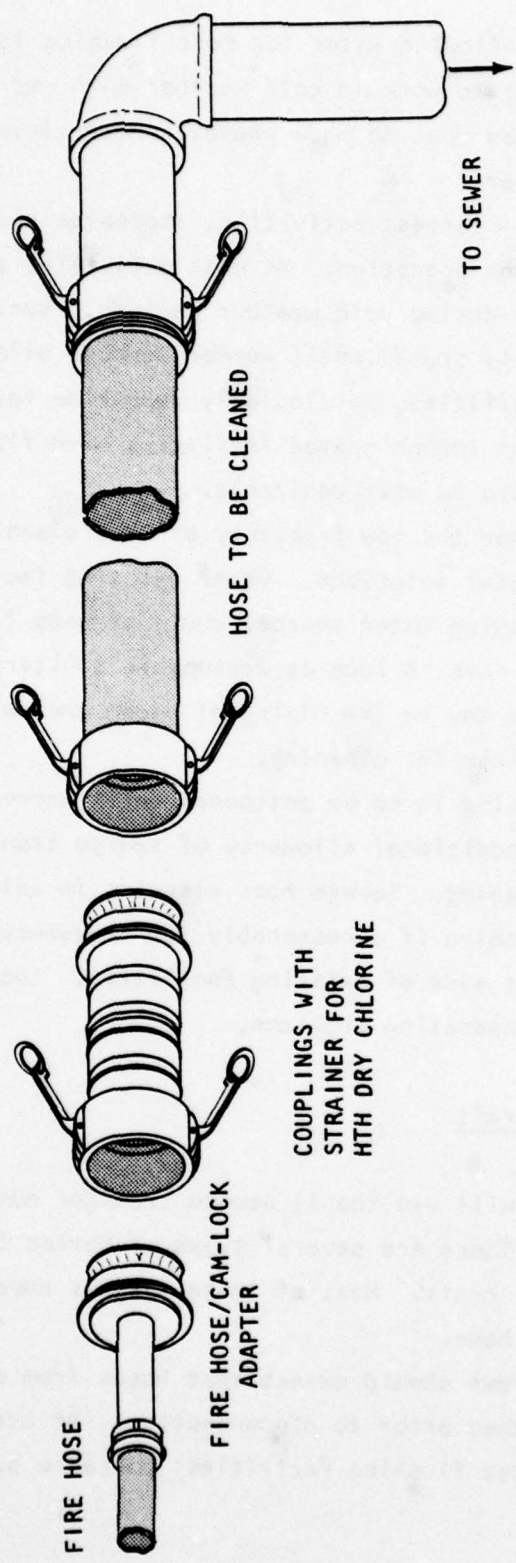

Figure 6. Chemical Cleaning Setup

The availability of flowing water for hose flushing is often reduced. The ability of personnel to work in cold weather with wet equipment is limited. Special consideration must be made whenever hose cleaning operations must occur in cold weather.

At all but the largest activities, shoreside cleaning of sewage hose will be an infrequent operation. At most activities sewage hose need not be cleaned immediately during cold weather periods. Uncleaned hose could be marked and separately stored until warmer weather allows this work.

At larger facilities, particularly submarine facilities in cold weather (such as New London) indoor heated facilities with flushing water source and sanitary drains would be most desirable.

In cold weather the low frequency of hose cleaning allows for many alternatives for local solutions. Other existing facilities, such as heated garages with a flushing water source, could be used for the few hours that it takes to clean the hose as long as reasonable sanitary precautions are taken. Another alternative may be the mixing of steam and water for hose flushing to keep the hose flexible for cleaning.

If hose cleaning is to be postponed until warmer weather, the activity should request an additional allowance of sewage transfer hose to make up for hoses awaiting cleaning. Sewage hose cleaning in cold weather is not a difficult problem to solve if a reasonably low frequency of hose cleaning is required and use is made of existing facilities. Local initiative can solve most cold weather operating problems.

## 2.5 Small Craft

Small craft will use the 1½ sewage transfer hose to discharge collected sewage to shore. There are several types of Marine Sanitation Devices (MSD) installed on small craft. Most of these systems have only a limited ability to flush transfer hose.

Shoreside crews should expect that hoses from most small craft will not be adequately flushed prior to disconnection. At activities with large numbers of small craft, hose flushing facilities (portable pump or designated hydrant)

may be desired and located near small craft piers. Normally, sewage is transferred from small craft only once every few days. Therefore it may be necessary to completely flush the hose only after last transfer of the day has been completed.

### 3. FACILITY REQUIREMENTS

This chapter discusses general design requirements for a facility to maintain, clean and store sewage transfer hose. The facility also may contain facilities for personnel. The requirements of this section are developed from health and sanitation requirements of BUMED, sanitary engineering requirements and practical operational requirements. The construction of new facilities for sewage hose support is not always needed, or recommended. Designers should follow the guidelines to determine the need for new facilities or modification of existing facilities.

#### 3.1 BUMED Requirements

The Bureau of Medicine and Surgery in keeping with its responsibility to limit the spread of disease is concerned with the design of facilities for the maintenance, cleaning and storage of sewage handling equipment. BUMED does not require that special facilities be constructed for this purpose but that if facilities are constructed or are used for this purpose, they must meet certain standards. The following requirements have been stated in correspondence for the review of NAVFAC designs but never have been formally incorporated into NAVFAC standards.

- A. Facilities or designated areas used for sewage hose maintenance, cleaning or storage must be located at an adequate and safe distance from any other facility or area which is used for potable water hose. This exclusion would also apply to those facilities which are used for food storage, preparation or transport or similar activity. Facilities or designated areas should be located away from busy traffic areas.
- B. If fresh water hydrants or risers are used for sewage hose flushing connections, they must not also be used for shipboard potable water.

These fresh water lines must be equipped with backflow preventers. If a fresh water hydrant is used for sewage hose cleaning, it should be designated as such.

- C. Sanitary drains must be used for sewage hose flushing and draining.
- D. Floors and walls must be constructed of a cleanable material. Floors or walls constructed of wood or highly porous materials would be unacceptable. Concrete floors, metal walls or sealed cinder block walls would be acceptable.
- E. Floors should have suitably roughened surfaces or safety grates to prevent slipping. National Sanitation Foundation Standard #52 applies to appropriate supplemental flooring.
- F. Any racks used to dry or store sewage hose should be constructed of non-porous material. Wooden storage and drying racks are not acceptable. Metal or concrete racks would be acceptable.
- G. Shower and toilet facilities shall be available for worker personal hygiene. Locker facilities for clothing shall also be available. The construction of these facilities must also be of materials which are easily cleanable.
- H. Lunchroom facilities for personnel must be designed in accordance with NAVMED P5010 Manual of Naval Preventive Medicine, Chapter 1, Foodservice Sanitation, with particular emphasis that hand washing facilities are readily available.
- I. In all work spaces lighting must be vapor-proof to prevent shock hazards from accidental water spray.
- J. Water coolers must be located in areas away from sewage hose cleaning and free from water spray contamination.
- K. Window and door screens are required for all enclosed structures.
- L. Adequate ventilation is required for closed structures to control odors. Forced ventilation may be required in warmer climates.

As with the hose cleaning requirements, the above design requirements are both practical and reasonable, and most can be met by existing facilities.

It should be noted that laundry facilities are not required. Although, sewage workers should have clean coveralls or work clothes, how these are provided is a local option. Work clothing can be the worker's responsibility

and contaminated clothing can be washed in regular home laundry loads. Some facility designers have placed washers and dryers within the personnel areas of hose maintenance facilities.

The ability of the sewage workers to have access to wash-up facilities must be stressed. Personnel must be encouraged to use any wash-up facility wherever it may be on the activity.

### 3.2 Operational Requirements

In addition to health and sanitary requirements, designs for new or existing facilities must allow for the proper cleaning, maintenance and storage of hoses and equipment.

- A. Designated areas for hose cleaning should be away from heavily trafficked areas.
- B. Hoses that are stored indoors should have sufficient air circulation to prevent odor build-up. For those that are stored outside, some protection from direct sunlight should be provided.
- C. Hose cleaning facilities, whether permanent or temporary should have a minimum ability to provide direct flushing of sewage hoses with water (salt or fresh) at a rate of 150 to 300 gallons per minute.
- D. Adequate work space with a workbench must be available or otherwise designated for the performance of hose maintenance as described in NAVFAC Manual MO-340, chapter 11.
- E. Regular hose maintenance requires the hydrostatic testing of hose to 100 PSI at least quarterly for those hoses which are in continuous use. Provisions should be made to use either industrial shop supplied air or portable compressors, as necessary, for this maintenance task.
- F. A source of low pressure steam should be available for steam degreasing of hoses. This can be provided by designating a steam riser for this use.
- G. Backflow preventers on potable water lines must be used whenever there is a possibility of cross connection to contaminated hoses or fittings.

H. Secure storage areas for equipment should be provided.

Fully dedicated buildings and areas are not always required and are difficult to justify for the small quantity of hose cleaning and maintenance that will be performed at most activities. The above requirements can be met by most activities using existing assets. Local initiative is necessary to set up a hose support program. Hose maintenance at a small activity could be performed by a neighboring larger command or by another public works department shop.

Appendix A provides a check-list to determine the requirements for use of existing or design of new facilities for hose maintenance, cleaning, storage and personnel facilities.

#### 4. MINIMUM FACILITY DESIGNS

This chapter develops facility requirements for four typical facilities. These are:

Large and small warm weather activities

Large and small cold weather activities

The facilities described meet the minimum requirements of BUMED and the practical operating needs for hose support services. Design elements for these facilities are listed in Table 2 and Table 3.

##### 4.1 Large Warm Weather Activity

An example of a large warm weather activity would be one which has at least ten ship departures, including submarines, per week in a climate without freezing weather as typically found in the Southern California, Gulf Coast or Florida coast areas.

If such an activity has ten departures per week, and two of these are submarines, this would result in 24 lengths of 4-inch hose and 12 lengths of 2½-inch submarine hose to be disconnected. Using Table 1, this would mean about three lengths of 4-inch hose and all 12 lengths of the 2½-inch hose would require shoreside flushing each week.

Further cleaning beyond flushing would be required for 1 length of 4-inch hose per month and 1 length of 2½-inch hose every two months. With these numbers in mind, the minimum requirements for that activity to provide sewage hose support can be developed.

Hose cleaning requirements. Since the majority of shoreside hose cleaning would be due to the submarine activity, a hose flushing area near the submarine piers should be designated and used for all hose flushing. At this area it will be assumed that pier saltwater is not available. A 3-inch diesel driven salvage pump should be placed on the pier to take suction

TABLE 2. WARM WEATHER FACILITY SIMPLIFIED DESIGNS

	Large Warm Weather Activity	Small Warm Weather Activity
<b>Cleaning Frequency</b>		
Flushing	3 lengths 4" hose 12 lengths 2½" hose per week	1 length 4" hose per month
Additional Cleaning	1 length 4" hose 0.5 length 2½" hose per month	1 length of 4" hose per year
<b>Cleaning Facility</b>	Pier side installed 3 inch diesel pump. Steam and sanitary sewer at permanent outdoor area.	Portable P250 pump. Temporary outdoor area designated for cleaning.
<b>Maintenance</b>	Dedicated area for workbench in utility yard.	Uses existing utility department workbench and shop when needed.
<b>Storage</b>	Outside fenced storage with metal racks.	Outside area in fenced utility yard. Hoses stored on ground and covered.
<b>Personnel Facilities</b>	Special facilities for hose crews constructed.	Personnel use existing utility department showers, washroom and lockers.

TABLE 3. COLD WEATHER FACILITY SIMPLIFIED DESIGNS

	Large Cold Weather Facility	Small Cold Weather Facility
<b>Cleaning Frequency</b>		
Flushing	42 lengths of 2½" hose per week	1 length of 4" hose per month
Additional Cleaning	2 lengths of 2½" hose per month	1 length of 4" hose per year
<b>Cleaning Facility</b>	Permanent outdoor designated cleaning area near piers, sanitary drain and steam line for warm weather. Cold weather indoor heated cleaning facilities provided in storage/maintenance building.	Portable P250 pump used for flushing in warm weather. In cold weather, dirty hoses are stored outside until warm weather allows flushing.
<b>Maintenance</b>	Workbench and equipment provided in storage/maintenance building.	Uses existing utility department workbench and shop when needed.
<b>Storage</b>	Bulk of hose stored outside in fenced yard, covered by a tarp. In cold weather clean working lengths are kept in heated storage buildings.	Outside area in fenced utility yard, covered by a tarp. In cold weather clean working lengths are stored in heated utility garage.
<b>Personnel Facilities</b>	Special facilities for hose crews constructed as part of storage/maintenance building.	Personnel use existing utility department showers, washroom and lockers.

through a screened suction hose dropped into the harbor when required. This hose cleaning area will use the pier sewer riser to receive hose flushing water. A nearby steam riser can also be used for occasional steam degreasing of contaminated hose. For chemical cleaning, the activity would use chlorine for occasional hose soaking and keep all equipment in a storage locker in a workshop area. All adapters and other fittings would also be kept in this locker.

Hose maintenance facilities. The maintenance of hoses would be performed in a wholly dedicated area in the utility yard. The maintenance facility would consist of a large workbench with pipe vises located under an open shed in a fenced utility yard. Hydrostatic testing of the hose would be performed at the hose cleaning area using a portable air compressor.

Hose storage. Hose would be stored within the utility yard on open galvanized metal racks. The racks will hold two classifications of hose. Hose which is infrequently used and is stored in inventory would be kept in coils on the racks. On the lower portion of the racks and on the ground would be placed lengths of regularly used hose. All hose in storage can be protected from the sun by tarpaulins.

Personnel Facilities. Shower and toilet facilities for personnel would be located in a small metal building adjacent to the maintenance area. The building would have showers, toilets, sinks, watercooler, a lunchroom, office and tool storage lockers. Workers would provide their own work clothing.

#### 4.2 Small Warm Weather Activity

One ship departure per week will be assumed for the small activity. Using the percentages for surface vessels in Table 1, the activity will disconnect 3 hoses per week of which about 1 per month will require additional flushing. Of these perhaps 1 or 2 hoses per year will require cleaning beyond shoreside water flushing. Because of this activity's low hose use, hose maintenance and repair will be proportionately low. At this activity, no permanent sewage hose support facilities will be constructed.

Hose Cleaning. Approximately once a month 1 length of sewage hose will require flushing. This activity will use a portable P250 pump from the base fire department whenever this is necessary. The pump would be set up on a quiet end of the pier near a receiving sewer riser. If additional cleaning is required (about 1 hose per year), chemical cleaning can be accomplished using chlorine tablets for hose soaking. All tools, adapters and chemicals would be kept in a storage locker at the utility shop. If steam cleaning is required, the hose can be transported to another location where a steam riser would be located near a sanitary drain. Again, this operation may occur only once a year.

Maintenance Facilities. Occasional repair of sewage hoses and fittings can be performed in a work shop on a utility department workbench. Hand banding tools can be used. This workbench would be located in a different building than potable water hoses. All tools and spare fittings would be kept in a separate utility locker.

Hose Storage. All sewage hoses would be stored outside along with working adapter fittings. The hose can be stored on a concrete apron having good drainage and covered with a tarpaulin. The storage area would be enclosed by a security fence.

Personnel Facilities. No special personnel facilities would be provided for those working with sewage transfer hose. Personnel can use toilet and shower facilities used by all base workers. Sewage hose handling crews will not be assigned on a full-time basis but will be integrated into other utility support services, except subsequent portable water hookups.

#### 4.3 Large Cold Weather Activity

The large cold weather activity presents the most difficulty for developing sewage hose support facilities. At this activity it will be assumed that mostly submarines are handled with 7 departures per week. The activity will have 3 months of below freezing weather every year. Using the percentages in Table 1, this will produce 42 sewage hoses per week requiring shore-side flushing. Of these approximately 2 hoses per month will require additional cleaning beyond flushing. The following facility setup will adequately service the hose cleaning needs.

Cleaning Facilities. Throughout the year the majority of hose cleaning will be accomplished by a semi-permanently installed 3-inch diesel salvage pump located on a quay wall. For at least 9 months a year all hoses can be flushed using this pump, which would be located near a pier sewer riser. Also, this location would have a steam riser for those hoses requiring degreasing. During cold weather, hose flushing can be accomplished inside a heated hose storage and maintenance building. This building could be an existing structure adapted for sewage hose cleaning. The working floor length required for the building is at least 50 feet. The floor would have a new, sealed concrete deck with a roughened non-skid surface, sloping to sanitary floor drains. No troughs, trays or racks would be used. The hose would be brought into the building and laid directly onto the concrete deck. Hose flushing would be accomplished by fresh water from a 2½-inch main protected by a backflow preventer. The main would have a manifold with four camlock connections to handle multiple sewage hoses. At the far end of the building a similar manifold with female camlocks would be located to discharge the flushing water directly into a sanitary drain. The hoses can be drained by an air blowdown fitting located in the fresh water manifold. A low pressure steam fitting, located adjacent to the fresh water manifold, would provide steam for hose degreasing. The old wooden walls of the building would be covered with fiberglass paneling to provide a cleanable surface. All lighting would be vapor-proof and shock-proof. Chemical cleaning of hoses can be performed by soaking the interior of the hose with a disinfecting detergent which can be aspirated into the hose using a fitting adapter. This facility should expect only 2 hoses per month requiring cleaning beyond the fresh water flushing.

Hose Maintenance Facilities. All hose maintenance would be performed in the building described above. Since hose flushing operations can be accomplished without using racks on the concrete deck, a full working area is available whenever hoses are not being flushed. In this building a large workbench would be located with pipe vises and necessary tools. Hydrostatic testing can be performed using industrial shop supplied air and the fresh water manifold system. Forced ventilation would be provided during warm weather with all doors and windows fully screened.

Hose Storage Facilities. Hose storage would be provided in two locations. In the maintenance building, described above, long metal storage racks are provided for storage of working sewage hose. After the hose is flushed and drained it would be placed on these racks and available for reuse. Additional hose inventory would be stored outside on similar metal racks. During freezing weather needed hoses could be moved inside to thaw-out before use. Hoses awaiting cleaning would be kept outside in all weather, uncapped to promote air circulation.

Personnel Facilities. Personnel facilities including showers, toilets, lockers and lunchroom would be located immediately adjacent to the hose maintenance, storage and cleaning bay. New interiors for these facilities can be provided by installing metal and fiberglass paneling for walls and tile flooring throughout the personnel areas of the facility.

#### 4.4 Small Cold Weather Activity

Hose support facilities for a small cold-weather activity would be very similar to facilities for a small warm-weather activity. Assuming a hose use frequency similar to the small weather activity presented in Section 4.2, all facilities would be temporary, or borrowed from other services. Also assuming that three months of freezing weather would preclude outside hose flushing, several alternatives exist to provide hose support facilities.

The one hose a month that would require additional flushing could be stored until warmer weather. This would increase the activity's hose inventory by about three lengths. Flushing of hoses could also be performed by simultaneous use of steam and flushing water. Clean working lengths of sewage hose can be stored during freezing months in a heated garage. This would insure flexible hose lengths for ship connection.

## 5. CONCLUSIONS

### 5.1 Hose Cleaning Frequency

The practical application of BUMED requirements and common sense has reduced the problem of hose cleaning and maintenance to very manageable levels at even the largest Navy activities. The expected low frequency of hose cleaning will generally preclude the need for large wholly dedicated facilities. If an activity, no matter what size, can find some way of providing flushing water, salt or even fresh water, almost all hose cleaning needs can be met. There seems to be no reason why any activity should postpone using pier sewers for lack of hose support facilities.

### 5.2 BUMED Requirements

The BUMED requirements for hose cleaning, personnel health and sanitation and facility construction requirements are practical and can be easily met by most activities. The requirements allow for local alternatives to meet the intent of BUMED regulations. In most cases, existing facilities with few modifications can be used for sewage hose support. NAVFAC Engineering Field Divisions can provide valuable local assistance in developing a hose support program that meets these requirements.

### 5.3 Local Initiative

Local initiative is essential in developing sewage hose support facilities and procedures. Sewage transfer operations at most activities must begin slowly until confidence is gained and local problems are solved. There is no advantage in postponing operations until the last possible date, as most activities already have some ability to provide for at least partial sewage hose support.

#### 5.4 Consolidation of Hose Cleaning Functions

The duplication of hose support facilities within a region may not be justifiable. EFD's should examine regional sewage hose use and recommend consolidation of services. Regional use of personnel may be beneficial, particularly in the start-up phases of sewage transfer operations.

## 6. RECOMMENDATIONS

### 6.1 NAVFAC Guidance Update

In coordination with BUMED, NAVFAC should publish a technical note for all EFD's and PWC commands detailing BUMED and NAVFAC requirements for sewage hose cleaning and facility design requirements. Appropriate changes to DM5 and DM25 should also be prepared.

NAVFAC Ship-to-Shore Hose Handling Operations Manual MO-340 when revised, should contain clear information on sewage hose cleaning, with particular emphasis on expected frequency of these operations. In addition, the manual should contain examples of specific alternatives in providing sewage hose cleaning and a variety of large and small activities. BUMED guidelines should also be included in this manual.

### 6.2 Engineering Field Division Support

EFD environmental personnel must be fully familiar with BUMED and operational hose cleaning requirements. EFD's should be encouraged to make local interpretations of design requirements to meet BUMED and operational requirements. Each EFD must encourage local initiative in solving operational problems. The EFD's should work closely with the Navy Environmental Preventive Medicine Units or Naval Regional Medical Center Preventive Medicine Service, as appropriate.

### 6.3 Regional Consolidation of Hose Support Activity

At activities where the number of sewage transfer operations will be low, the local NAVFAC EFD should determine if regional consolidation of services is practical.

#### 6.4 Local Area SOPA Instructions

Since most shipboard sewage transfer systems have the capability to flush sewage transfer hose, and with this, the majority of hose cleaning is performed, the compliance with the flushing requirement is essential to control shoreside maintenance work loads. Area SOPA Admin instructions must include strong requirements for compliance with shipboard flushing operations. NAVFAC EFD's should insure that regional SOPA instructions are prepared and the reason for hose flushing understood by ship operating commands. Navy Environmental Preventive Medicine Units or Naval Regional Medical Center Preventive Medicine Services, as appropriate, may be helpful in coordinating these efforts.

#### 6.5 Ship and Shore Working Relations

The training of shoreside personnel should emphasize the need for good relations with shipboard personnel. Pre sewage hose connection and disconnection conferences are essential to insure safe procedures and properly flushed sewage hose.

Local shore commands should consider industrial charges to those ships with hoses requiring additional cleaning as the result of neglect of shipboard flushing.

APPENDIX A

HOSE SUPPORT FACILITY

DESIGN CHECK LIST

APPENDIX A

SEWAGE HOSE SUPPORT FACILITIES CHECK LIST

1. HOSE CLEANING

- a. Number of hoses (50' lengths) disconnected per week
  - ship hose \_\_\_\_\_
  - sub hose \_\_\_\_\_
- b. Hoses requiring cleaning, flushing
  - 10% of ship hose \_\_\_\_\_
  - 100% of sub hose \_\_\_\_\_
- c. Hoses requiring additional cleaning, steam or chemical
  - 1% of ship total \_\_\_\_\_
  - 1% of sub total \_\_\_\_\_
- d. Flushing water source
  - Saltwater \_\_\_\_\_
  - pier firemain \_\_\_\_\_
  - portable pump \_\_\_\_\_
  - Other \_\_\_\_\_
  - or Freshwater \_\_\_\_\_
  - backflow preventer \_\_\_\_\_
  - designated hydrant \_\_\_\_\_
  - not used by ships \_\_\_\_\_
  - remote location \_\_\_\_\_
- e. Sanitary drain available \_\_\_\_\_
- f. Designated steam riser available near a sanitary drain for hose degreasing \_\_\_\_\_
- g. Cleaning area of facility isolated from potable water hose cleaning, storage, food preparation area or similar activity. \_\_\_\_\_

h. Chemical cleaning

chlorine tablets, HTH \_\_\_\_\_  
or detergent \_\_\_\_\_  
equipment available \_\_\_\_\_

i. Adapter fittings available

flushing adapter \_\_\_\_\_  
steam adapter \_\_\_\_\_  
reducer fittings \_\_\_\_\_  
other \_\_\_\_\_  
\_\_\_\_\_ \_\_\_\_\_  
\_\_\_\_\_ \_\_\_\_\_

2. CLEANING FACILITIES

- a. Floors constructed of cleanable material \_\_\_\_\_
- b. Surface roughened to prevent slipping, grating \_\_\_\_\_
- c. Walls constructed of cleanable materials \_\_\_\_\_
- d. Racks and wash tables are non-porous material  
(not wood) \_\_\_\_\_
- e. Lighting is rugged and vapor proof \_\_\_\_\_
- f. Electrical outlets and fixtures waterproof \_\_\_\_\_
- g. Doors and windows protected by screens \_\_\_\_\_
- h. Adequate ventilation provided \_\_\_\_\_
- i. Forced ventilation necessary \_\_\_\_\_
- j. Water coolers and personnel areas away from water  
spray areas \_\_\_\_\_

3. HOSE MAINTENANCE

- a. Workbench for repairs  
available \_\_\_\_\_  
dedicated \_\_\_\_\_
- b. Tool and parts locker \_\_\_\_\_

- c. 100 psi air for hydrostatic testing
  - shop air \_\_\_\_\_
  - portable compressor \_\_\_\_\_
- d. Location isolated from potable water hoses  
or similar activity \_\_\_\_\_

4. HOSE STORAGE

- a. Security adequate
  - fence \_\_\_\_\_
  - building \_\_\_\_\_
- b. Non-porous racks (not wood) \_\_\_\_\_
- c. Hoses protected from sun \_\_\_\_\_
- d. Adequate ventilation available \_\_\_\_\_
- e. Cold weather warm storage
  - available \_\_\_\_\_
  - dedicated \_\_\_\_\_
  - not required \_\_\_\_\_

5. PERSONNEL FACILITIES

- a. Facilities for wash up and showers, warm water
  - available and identified \_\_\_\_\_
  - near work area \_\_\_\_\_
  - dedicated facilities \_\_\_\_\_
  - constructed \_\_\_\_\_
- b. Facilities constructed of cleanable materials \_\_\_\_\_
- c. Lockers for work clothes
  - available \_\_\_\_\_
  - dedicated \_\_\_\_\_
- d. Lunchroom, if provided, in accordance with  
NAVMED P5010 \_\_\_\_\_
- e. Water cooler remote from water splash  
from hose cleaning \_\_\_\_\_
- f. Additional identified wash up facilities  
available throughout activity \_\_\_\_\_

g. Laundry

- home laundry \_\_\_\_\_
- or coverall service \_\_\_\_\_
- or washing machines \_\_\_\_\_
- available \_\_\_\_\_

6. COLD WEATHER ACTIVITIES

- a. Months of freezing weather \_\_\_\_\_
- b. Hose cleaning volume justifies interior  
heated cleaning facilities \_\_\_\_\_
- c. Additional hose allowance required to allow  
for uncleaned hose during freezing weather \_\_\_\_\_
- d. Heated hose storage to thaw out frozen hose  
temporarily available \_\_\_\_\_  
dedicated facility \_\_\_\_\_
- e. Steam mixing used to flush hose \_\_\_\_\_

APPENDIX B

SEWAGE HOSE ADAPTERS  
AND FITTINGS  
FOR LOCAL FABRICATION

## SEWAGE HOSE ADAPTERS AND FITTINGS

The following drawings provide designs for fittings to be used with ship to shore sewage transfer hose. The designs of these fittings have been simplified for local fabrication using locally available components.

The main component shown in these designs are cam-lock, hose shank couplings. These hose shank couplings are the most commonly used fittings at hose maintenance facilities. The designs can be modified as necessary to use other available components.

The adapters and fittings shown are the most commonly used to provide sewage hose services. Each activity must decide what fittings they need and if necessary develop special fittings for different local conditions.

Some of the fittings shown may be available from commercial sources. Cam-lock fittings are being Centrally Procured and stock numbers will be issued.

Most of the fittings shown use a modified cam-lock coupling with the hose shank cut off as shown in Figure 1. The modification can be substituted by commercially available cam-lock couplings such as:

- Adapter with socket welding end
- Coupler with socket welding end
- Adapter with N.P.T. end
- Coupler with N.P.T. end

Cam-lock couplings are manufactured under specification MIL-C-27487. Bronze couplings are available under this specification designated as; Coupling half, Quick Disconnect, Cam-Locking Type, Male, Hose Shank, Type II. Couplings are commercially available from:

Dover Corp./OPW Division, Cincinnati, Ohio  
Ever-Tite Coupler Co., New York, New York  
Parker Andrews Corp., Dayton, New Jersey

Designs for the following adapters and fittings are provided:

90° ELBOW

Provides a 90° turn for connecting sewage hoses. Also useful when connecting to piers with vertical sewer risers. Two of these fittings can be coupled to provide for complex bends for hose connections.

180° BEND

Provides a smooth change in direction for hose to riser connections.

"Y" CONNECTOR

Provides for two sewage hoses to be connected together to a common hose. Useful for ship nests and multiple connections to risers.

REDUCER

Allows smaller sewage hoses to be connected to 4" sewer risers.

STEAM ADAPTER

Provides for connection between cam-lock couplings and steam hoses using N.P.T fittings for steam degreasing of sewage hoses.

NOTE: Some activities may not use the 2" steam N.P.T. shown.

FIRE HOSE ADAPTER

Provides for connection between cam-lock couplings and 1½" fire hose N.P.T fittings for the flushing of sewage hoses for cleaning.

NOTE: Some activities may prefer a 2½" N.P.T.

IMCO FLANGE ADAPTER

Provides for a male cam-lock connection from a IMCO flange for sewage connections to foreign vessels or others with non U.S. standard fittings.

STRAINER ADAPTER

Provides a convenient strainer to hold HTH dry chlorine tablets for hose clorination.

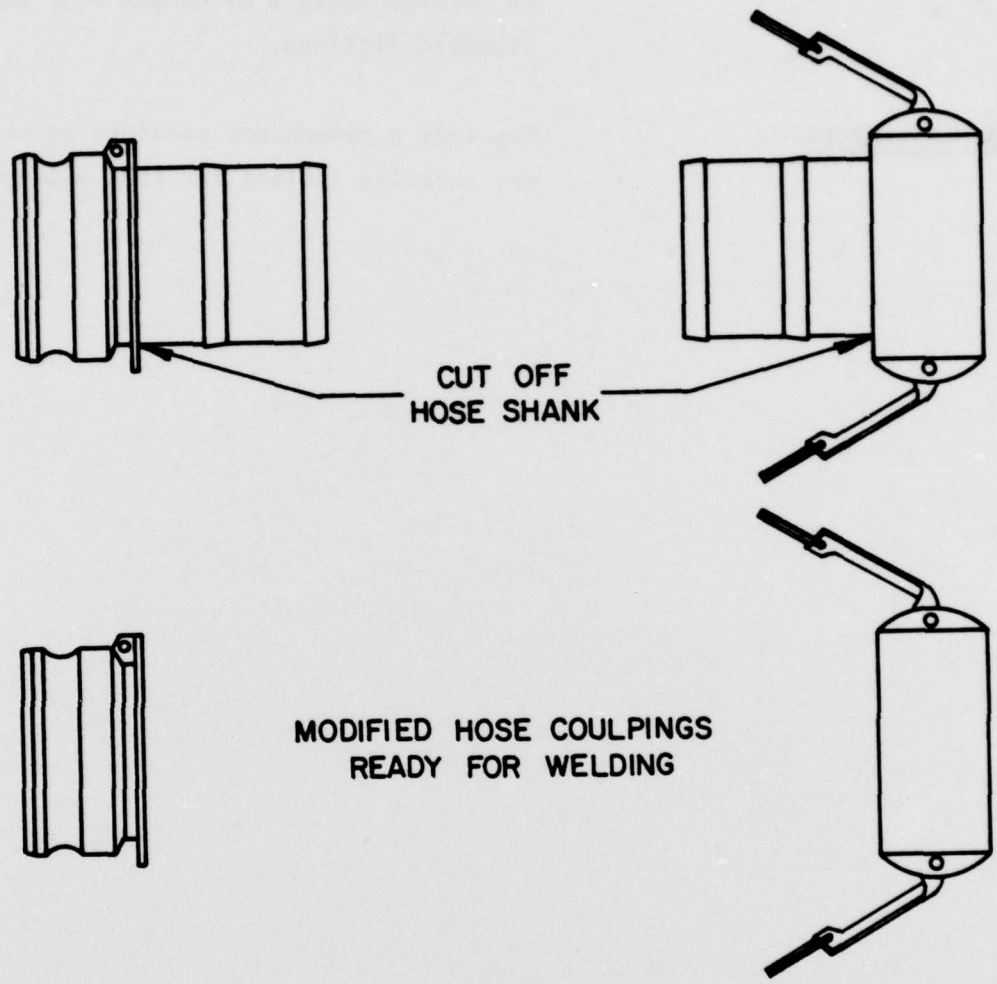

MODIFIED HOSE COUPLINGS  
READY FOR WELDING

Figure 1. Cam-Lock Modification

## 90° ELBOW (4, 2 1/2, 1 1/2)

PART	DESCRIPTION	DIMENSIONS (INCHES)		
A	CAM-LOCK, FEMALE	4	2 1/2	1 1/2
B	CAM-LOCK, MALE	4	2 1/2	1 1/2
C	ELBOW 90°	4	2 1/2	1 1/2
D	TUBE (SCH. 40)	4	2 1/2	1 1/2
	TUBE MIN. LENGTH (e)	2 1/2	2	1 1/2

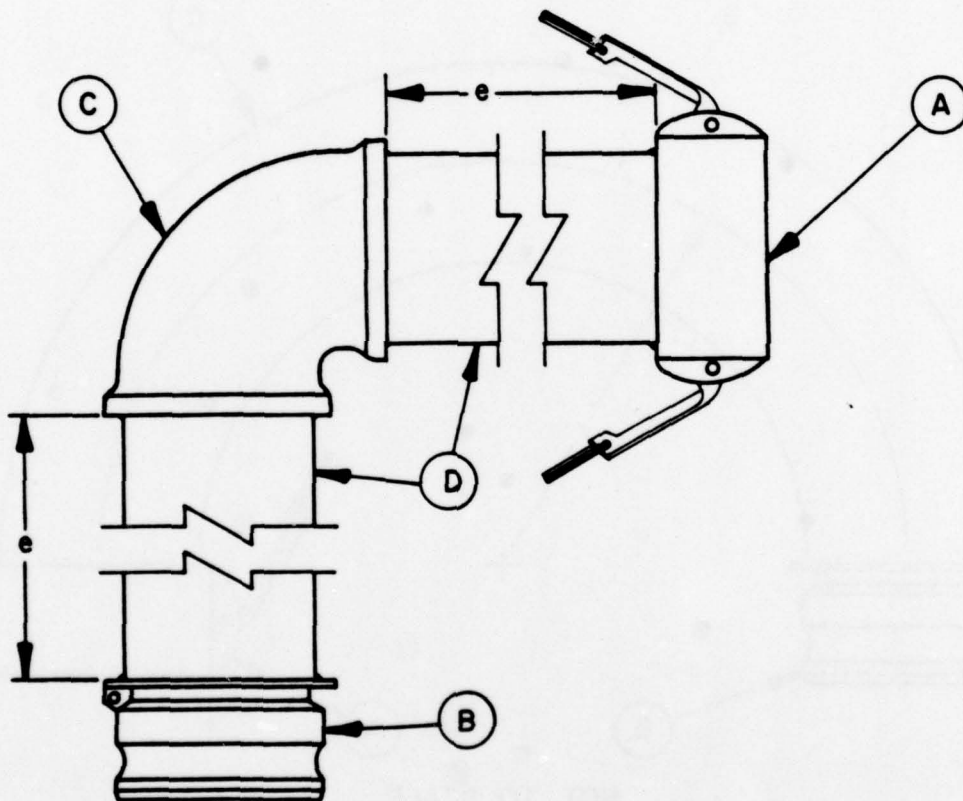

- NOTES:**
1. SEE FIGURE 1 FOR CAM-LOCK MODIFICATION.
  2. ALL JOINTS BRAZED.
  3. DESIGN WORKING PRESSURE IS 150 PSI.
  4. CAM-LOCKS AND ELBOW ARE BRONZE; TUBE IS Cu/Ni.
  5. ELBOW IS SOCKET WELDING TYPE.

# 180° BEND (4, 2 1/2, 11/2)

PART	DESCRIPTION	DIMENSIONS (INCHES)		
		4	2 1/2	1 1/2
A	CAM-LOCK , FEMALE	4	2 1/2	1 1/2
B	CAM-LOCK , MALE	4	2 1/2	1 1/2
C	TUBE (SCH. 40)	4	2 1/2	1 1/2
	TUBE MIN. RADIUS (r)	12	7 1/2	4 1/2

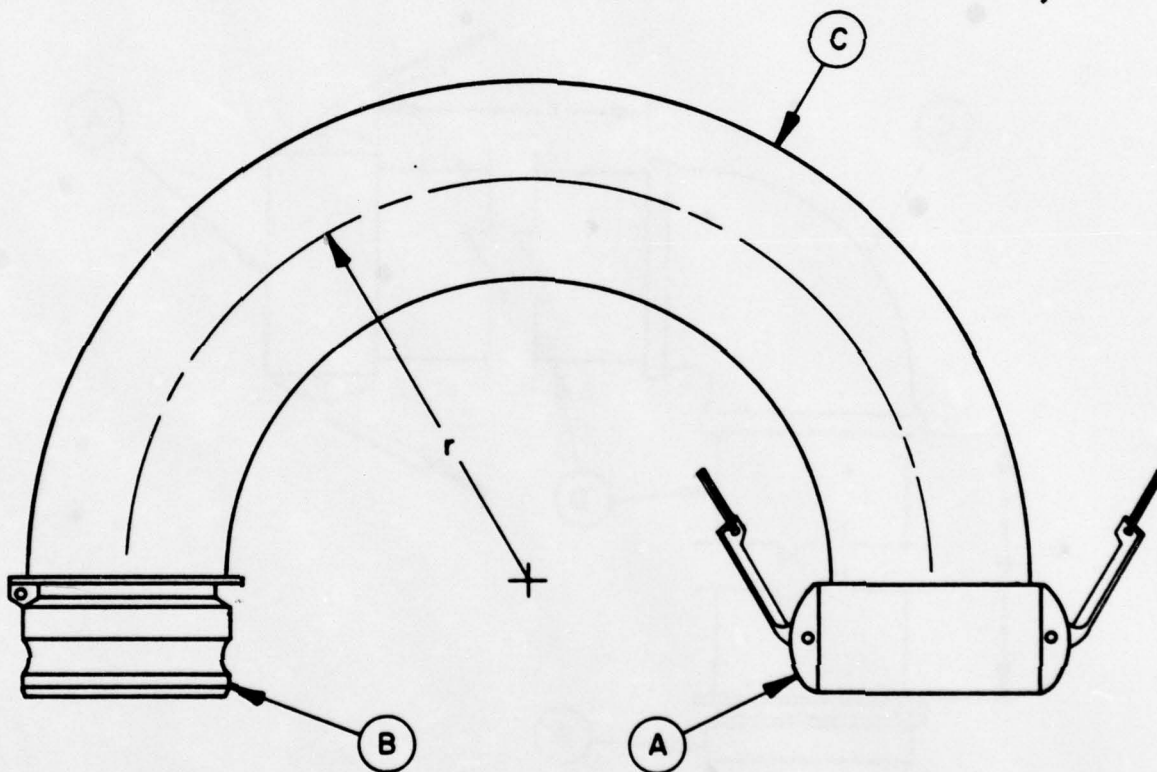

NOT TO SCALE

- NOTES:
1. SEE FIGURE 1 FOR CAM-LOCK MODIFICATION.
  2. ALL JOINTS BRAZED.
  3. DESIGN WORKING PRESSURE IS 150 PSI.
  4. CAM LOCK ARE BRONZE; TUBE IS Cu/Ni.

## "Y" CONNECTOR (4, 2 1/2)

PART	DESCRIPTION	DIMENSIONS (INCHES)	
A	CAM-LOCK, FEMALE	4	2 1/2
B	CAM-LOCK, MALE	4	2 1/2
C	TUBE (SCH. 40)	4	2 1/2
D	LATERAL	4	2 1/2
	TUBE MIN. LENGTH (e)	2 1/2	2

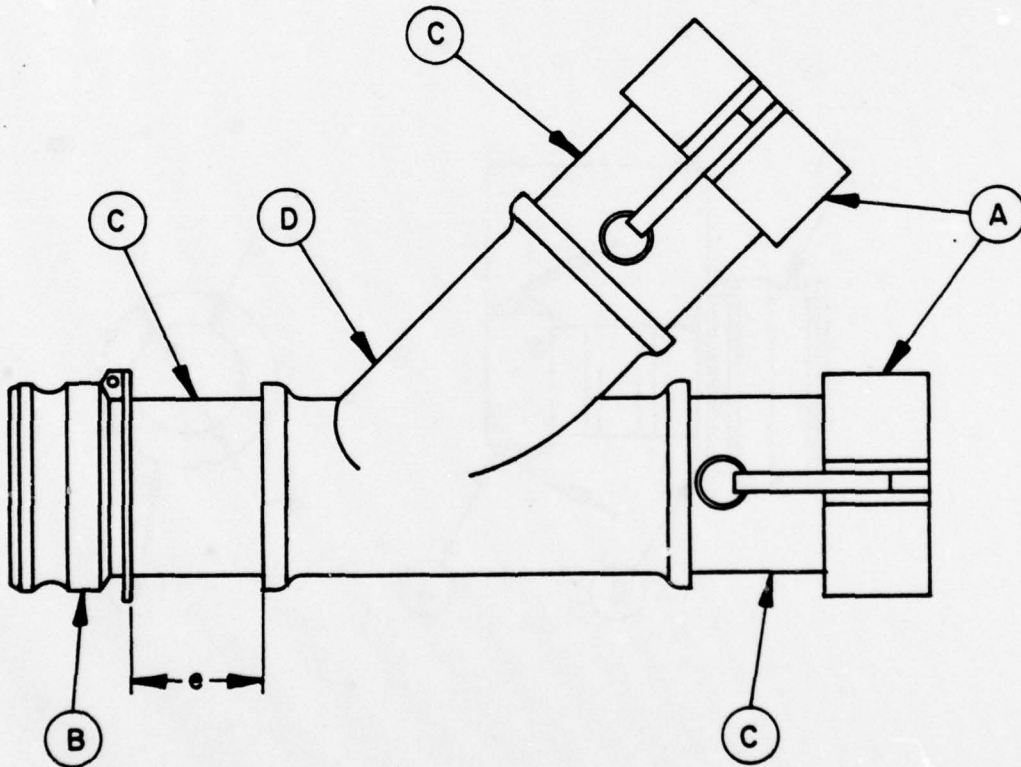

- NOTES:
1. SEE FIGURE 1 FOR CAM-LOCK MODIFICATION.
  2. ALL JOINTS BRAZED.
  3. DESIGN WORKING PRESSURE IS 150 PSI.
  4. CAM-LOCK AND LATERAL ARE BRONZE; TUBE IS Cu/Ni.
  5. LATERAL IS SOCKET WELDING TYPE.

## REDUCER (2 1/2 X 4, 1 1/2 X 4)

PART	DESCRIPTION	DIMENSIONS (INCHES)	
A	CAM-LOCK , FEMALE	2 1/2	1 1/2
B	CAM-LOCK , MALE	4	4
C	ADAPTER (d)	4	4
	(e)	2 1/2	1 1/2
	(f)	5 1/2 MIN.	6 MIN.

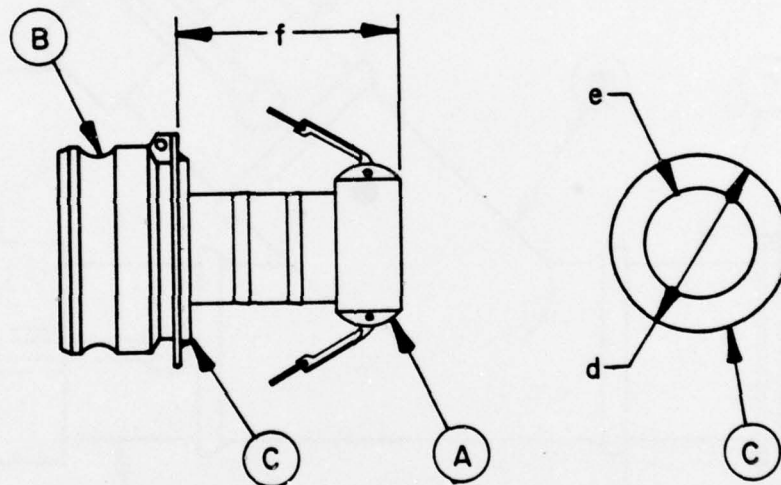

- NOTES:**
1. SEE FIGURE 1 FOR MALE CAM-LOCK MODIFICATION.
  2. ALL JOINTS BRAZED.
  3. DESIGN WORKING PRESSURE IS 150 PSI.
  4. CAM-LOCK ARE BRONZE; ADAPTER IS 1/4-INCH Cu/Ni OR BRASS PLATE.
  5. FEMALE CAM-LOCK IS USED WITH HOSE SHANK.

## STEAM ADAPTER (4, 2 1/2, 1 1/2)

PART	DESCRIPTION	DIMENSIONS (INCHES)		
A	CAM-LOCK, MALE	4	2 1/2	1 1/2
B	TUBE (SCH. 40)	2	2	2
C	UNION	2	2	2
D	ADAPTER (e)	2	2	1 1/2
	(f)	4	2 1/2	2

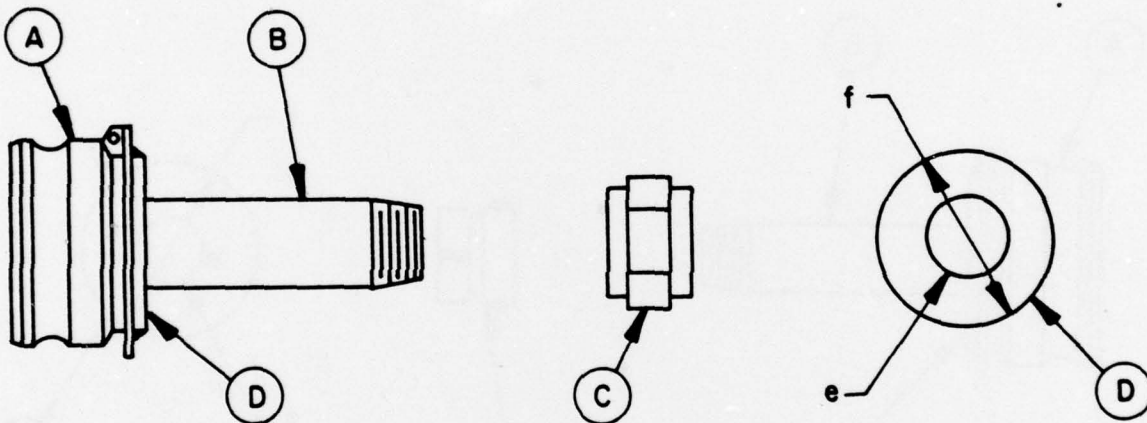

- NOTES:**
1. SEE FIGURE 1 FOR CAM-LOCK MODIFICATION.
  2. ALL JOINTS BRAZED.
  3. DESIGN WORKING PRESSURE IS 150 PSI.
  4. CAM-LOCK IS BRONZE; TUBE IS Cu/Ni; ADAPTER IS 1/4-INCH Cu/Ni OR BRASS PLATE.
  5. UNION IS 2-INCH N.P.T.-BLACK IRON, NSN 4730-189-2619.
  6. THREAD TUBE FOR 2-INCH N.P.T. AND ADJUST DIAMETER TO FIT LOCAL STEAM HOSE AND FITTINGS.

## FIRE HOSE ADAPTER (4, 2 1/2, 1 1/2)

PART	DESCRIPTION	DIMENSIONS (INCHES)		
A	CAM-LOCK, MALE	4	2 1/2	1 1/2
B	TUBE (SCH. 40)	1 1/2	1 1/2	NA
C	UNION	1 1/2	1 1/2	1 1/2
D	ADAPTER (e)	1 1/2	1 1/2	NA
	(f)	4	2 1/2	NA

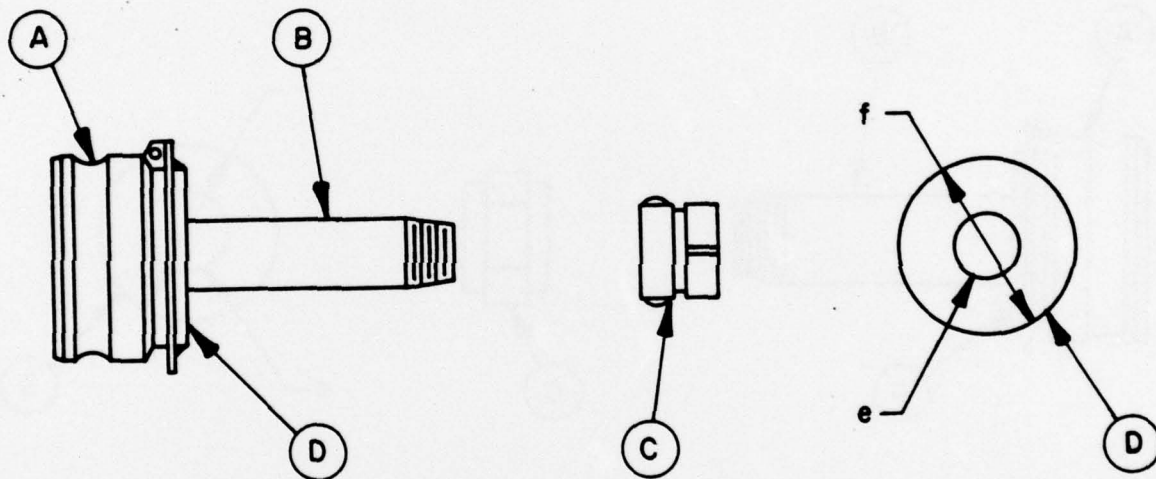

- NOTES:**
1. SEE FIGURE 1 FOR CAM-LOCK MODIFICATION.
  2. ALL JOINTS BRAZED.
  3. DESIGN WORKING PRESSURE IS 150 PSI.
  4. CAM-LOCK IS BRONZE; TUBE IS Cu/Ni; ADAPTER IS 1/4-INCH Cu/Ni OR BRASS PLATE.
  5. UNION IS 1 1/2-INCH N.P.T.-BRASS, NSN 4210-307-4699.
  6. 1 1/2-INCH CAM-LOCK WITH HOSE SHANK CAN BE MACHINED TO ACCEPT 1 1/2-INCH N.P.T.

## IMCO FLANGE ADAPTER (4, 2 1/2)

PART	DESCRIPTION	DIMENSIONS (INCHES)	
A	CAM-LOCK , MALE	4	2 1/2
B	ADAPTER FLANGE (c)	6 11/16	6 11/16
	(d)	4	2 1/2
	(e)	8 17/64	8 17/64
	(f)	5/8	5/8
	(g)	5/8	5/8

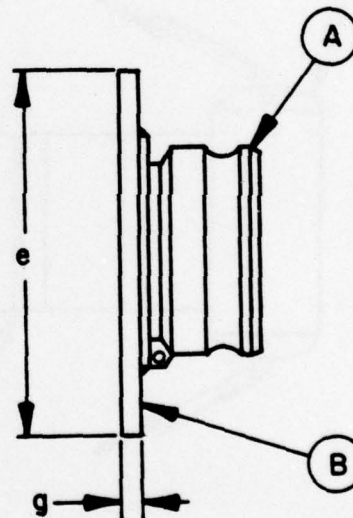
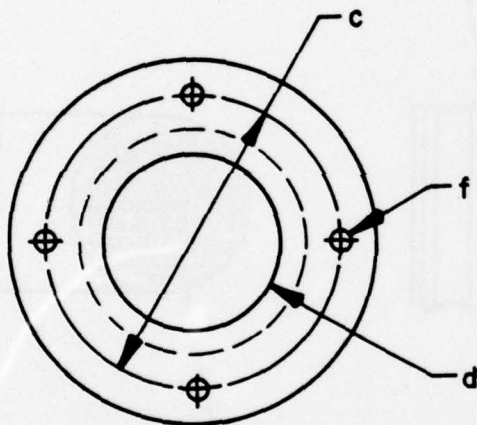

- NOTES:**
1. SEE FIGURE 1 FOR CAM-LOCK . MODIFICATION.
  2. ALL JOINTS BRAZED.
  3. DESIGN WORKING PRESSURE IS 150 PSI.
  4. CAM-LOCK IS BRONZE; ADAPTER FLANGE IS 5/8-INCH Cu/Ni OR BRASS PLATE.
  5. USE NEOPRENE GASKET MATERIAL.

## STRAINER ADAPTER FOR DRY HTH TABLETS (4, 2 1/2, 1 1/2)

PART	DESCRIPTION	DIMENSIONS (INCHES)		
		4	2 1/2	1 1/2
A	CAM-LOCK, FEMALE	4	2 1/2	1 1/2
B	CAM-LOCK, MALE	4	2 1/2	1 1/2
C	SCREEN DIAMETER (d)	4	2 1/2	1 1/2

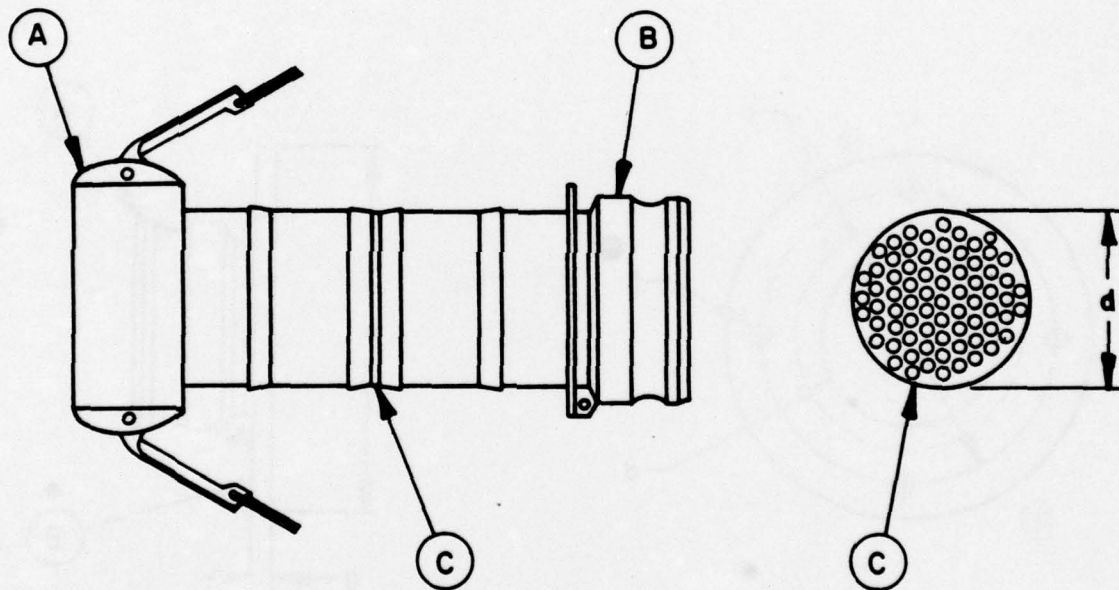

- NOTES:**
1. USE UNMODIFIED CAM-LOCK WITH HOSE SHANK.
  2. ALL JOINTS BRAZED.
  3. DESIGN WORKING PRESSURE IS 150 PSI.
  4. SCREEN IS 1/8-INCH Cu/Ni OR EQUIVALENT PLATE WITH 3/16-INCH HOLES OR PREFORMED MESH OR SCREEN.