

AD-A069 871

GRUMMAN AEROSPACE CORP BETHPAGE N Y
METALLIC COATINGS FOR GRAPHITE/EPOXY COMPOSITES. (U)
MAY 79 C J STAEBLER, B F SIMPERS

F/G 11/2

N00019-77-C-0250

UNCLASSIFIED

NL

| OF |
AD
A069871

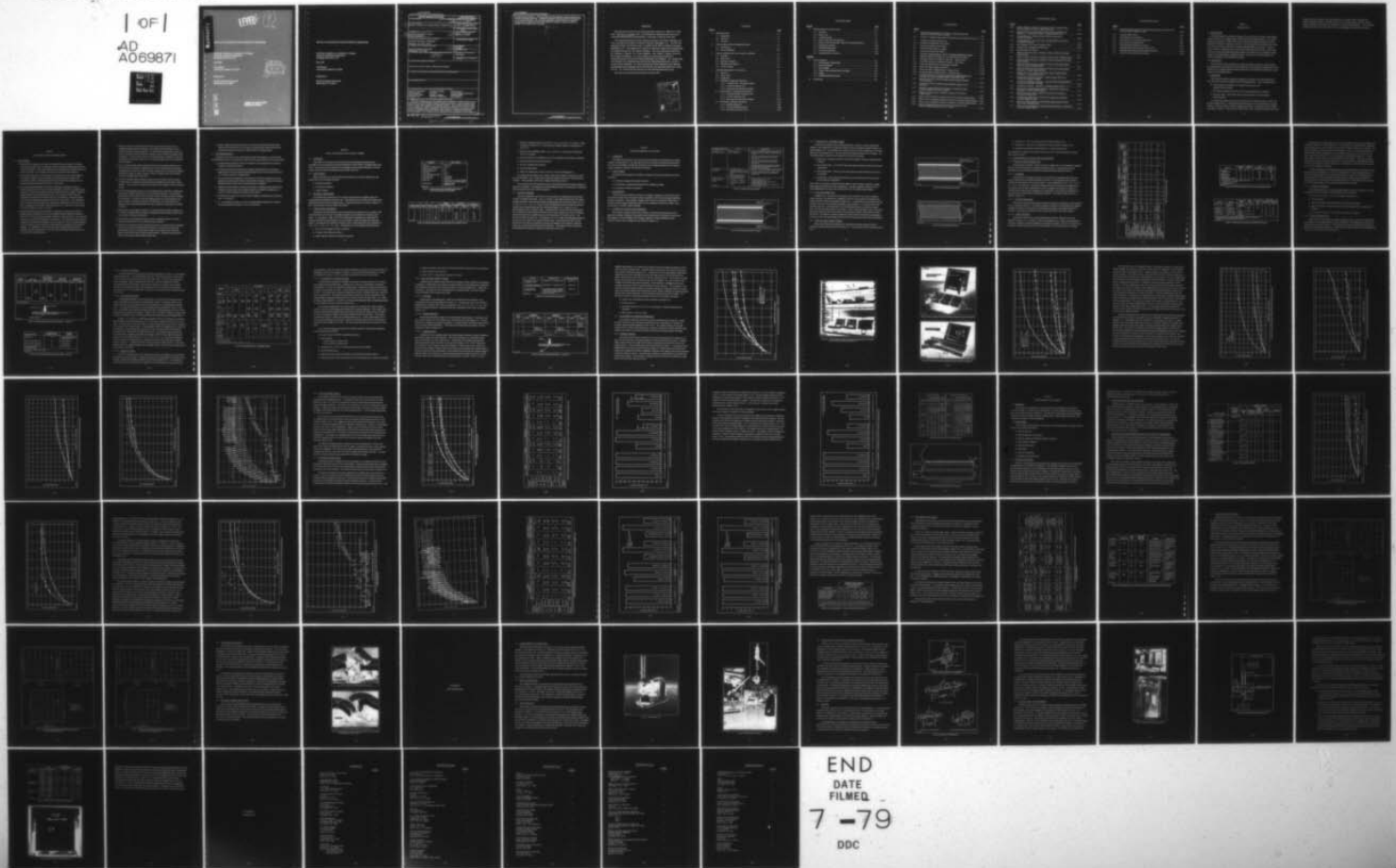

END
DATE
FILMED
7 -79
DDC

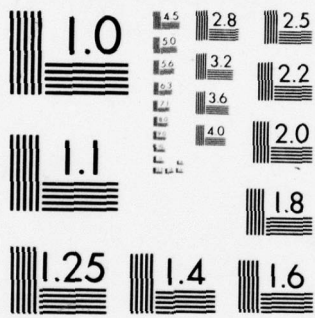

MICROCOPY RESOLUTION TEST CHART
NATIONAL BUREAU OF STANDARDS-1963-A

AD A069871

LEVEL

4

METALLIC COATINGS FOR GRAPHITE/EPOXY COMPOSITES

**Christian J. Staebler, Jr. and Bonnie F. Simpser
Grumman Aerospace Corporation
Bethpage, New York 11714**

May 1979

**Final Report
Contract No. N00019-77-C-0250**

Prepared for

**Naval Air Systems Command
Washington, D.C. 20361**

DDC
RECEIVED
JUN 13 1979
C

DDC FILE COPY

**APPROVED FOR PUBLIC RELEASE:
DISTRIBUTION UNLIMITED**

79 06 13 051

METALLIC COATINGS FOR GRAPHITE/EPOXY COMPOSITES

**Christian J. Staebler, Jr. and Bonnie F. Simpers
Grumman Aerospace Corporation
Bethpage, New York 11714**

May 1979

**Final Report
Contract No. N00019-77-C-0250**

Prepared for

**Naval Air Systems Command
Washington, D.C. 20361**

UNCLASSIFIED

SECURITY CLASSIFICATION OF THIS PAGE (When Data Entered)

REPORT DOCUMENTATION PAGE		READ INSTRUCTIONS BEFORE COMPLETING FORM
1. REPORT NUMBER	2. GOVT ACCESSION NO.	3. RECIPIENT'S CATALOG NUMBER
4. TITLE (and Subtitle)		5. TYPE OF REPORT & PERIOD COVERED
6. AUTHOR(s)		6. PERFORMING ORG. REPORT NUMBER
7. AUTHORING ORGANIZATION NAME AND ADDRESS		8. CONTRACT OR GRANT NUMBER(s)
9. CONTROLLING OFFICE NAME AND ADDRESS		10. PROGRAM ELEMENT, PROJECT, TASK AREA & WORK UNIT NUMBERS
11. MONITORING AGENCY NAME & ADDRESS (if different from Controlling Office)		12. REPORT DATE
13. DISTRIBUTION STATEMENT (of this Report)		13. NUMBER OF PAGES
14. DISTRIBUTION STATEMENT (of the abstract entered in Block 20, if different from Report)		15. SECURITY CLASS. (of this report)
15. SUPPLEMENTARY NOTES		15a. DECLASSIFICATION/DOWNGRADING SCHEDULE
16. KEY WORDS (Continue on reverse side if necessary and identify by block number)		
17. ABSTRACT (Continue on reverse side if necessary and identify by block number)		

6

9

Final rept.

1 May 1977 - October 1978

10

Christian J./Staebler, Jr. and Bonnie F./Simpers

15

N00019-77-C-0250

11

May 1979

12 94p.

Unclassified

Approved for public release; distribution unlimited

Advanced Composites Secondary Bonding Paint Strippers
 Graphite/Epoxy Cocuring Electromagnetic Interference
 Metal-Filled Resin Metallic Coatings Lightning Strike
 Aluminum Foil Moisture Penetration Serviceability

Metallc coating systems for graphite/epoxy laminated aircraft structures were developed to provide protection against moisture penetration, electromagnetic interference (EMI), paint strippers and lightning strikes. Foil coatings and metal-filled resin coatings were evaluated to assess the protection ability in each of these areas. The foil coatings provided a significant reduction in the moisture penetration and the associated strength loss of the laminate after exposure to humidity and humidity-thermal spiking. Two techniques were developed for the application of foil coatings to

DD FORM 1 JAN 73 1473

EDITION OF 1 NOV 65 IS OBSOLETE S/N 0102-014-6601

UNCLASSIFIED SECURITY CLASSIFICATION OF THIS PAGE (When Data Entered)

388 847

LB

UNCLASSIFIED

SECURITY CLASSIFICATION OF THIS PAGE(When Data Entered)

graphite/epoxy laminates. Solid aluminum foil was applied to cured laminates in a secondary bonding operation. Perforated aluminum foil was bonded to the laminate in a cocuring operation. The cocuring application required that the laminate be prebaked prior to application of the foil and final cocuring to obtain the optimum strength and thickness of the laminate.

UNCLASSIFIED

SECURITY CLASSIFICATION OF THIS PAGE(When Data Entered)

FOREWORD

This final report covers the work performed under Contract No. N00019-77-C-0250 from 1 May 1977 to 31 October 1978. It is published for information only and does not necessarily represent the recommendations, conclusions or approval of the Navy.

This contractual program with the Grumman Aerospace Corporation, Bethpage, New York, was funded by the Naval Air Systems Command, Washington, D.C. The work was administered under the direction of Mr. M. Stander of the Naval Air Systems Command, Washington, D.C. The program was conducted by Grumman's Material and Manufacturing Development Section, Mr. Carl Micillo, Manager. The work reported was directed by Mr. Christian J. Staebler, Jr., Project Engineer. Mrs. Bonnie F. Simperts served as the Principal Investigator. Mr. Peter Donohue of the Elements and Materials Testing Laboratory served as the Program Mechanical Test Engineer. Mr. George Lubin, Chief Scientist of the Manufacturing and Materials Engineering Department, served as overall Project Consultant. Mr. Einar Hoel and Mr. Robert Blackshaw of the Material and Manufacturing Development Section fabricated the test panels and applied the coating systems. Mr. Harold Schwenk performed the EMI shielding effectiveness tests.

This report was released for publication in January 1979.

Accession For	
NTIS GRA&I	<input checked="" type="checkbox"/>
DDC TAB	<input type="checkbox"/>
Unannounced	
Justification	
By _____	
Distribution/	
Availability Codes	
Dist	Mail and/or special
A	

CONTENTS

<u>Section</u>		<u>Page</u>
1	INTRODUCTION	1-1
	1.1 Background	1-1
	1.2 Objectives	1-1
	1.3 Approach	1-1
2	CONCLUSIONS AND RECOMMENDATIONS	2-1
	2.1 Conclusions	2-1
	2.2 Recommendations	2-3
3	PANEL FABRICATION AND CONTROL TESTING	3-1
	3.1 Approach	3-1
	3.2 Study Areas	3-1
	3.3 Material Properties	3-1
	3.4 Fabrication Techniques	3-1
	3.5 Control Testing	3-3
4	PROCESS SCREENING EVALUATION	4-1
	4.1 Approach	4-1
	4.2 Study Areas	4-1
	4.3 Background	4-1
	4.4 Candidate Coatings and Materials	4-1
	4.4.1 Aluminum Foil - Secondary Bonded	4-3
	4.4.2 Cocured Aluminum Foil	4-3
	4.4.3 Spray-and-Bake Metallic Coatings	4-3
	4.5 Development of Application Parameters	4-5
	4.5.1 Secondary Bonded Aluminum Foil	4-5
	4.5.2 Cocured Aluminum Foil	4-8
	4.5.3 Spray-and-Bake Metallic Coatings	4-13
	4.6 Evaluation of Moisture Resistance	4-15
	4.6.1 Humidity Exposure	4-15
	4.6.2 Thermal Spiking Exposure	4-26
	4.6.3 Mechanical Property Tests	4-26

CONTENTS (contd)

<u>Section</u>		<u>Page</u>
5	SERVICEABILITY EVALUATION	5-1
5.1	Approach	5-1
5.2	Study Areas	5-1
5.3	Coating Selection	5-1
5.4	Panel Preparation and Exposure	5-2
5.5	Moisture and Paint Stripper Effects on Strength Retention	5-2
5.6	Machining Evaluation	5-14
5.7	Shielding Effectiveness	5-17
5.8	Corrosion Evaluation	5-21
5.9	Lightning Strike Protection	5-21
<u>Appendix</u>		
A	Test Procedures	A-1
A.1	Environmental Conditioning	A-2
A.2	Impact Resistance	A-2
A.3	Peel Strength	A-2
A.4	Flexural and Horizontal Shear Strengths	A-5
A.5	Fatigue	A-5
A.6	EMI Shielding Effectiveness	A-7
B	Distribution	B-1

ILLUSTRATIONS

<u>Figure</u>		<u>Page</u>
3-1	Physical Characteristics of AS/3501-6 Graphite/Epoxy Tape (Hercules Procedure HD-SG-2-6606)	3-2
3-2	AS/3501-6 Graphite/Epoxy Material Qualification and Bleeder Prove-out . . .	3-2
4-1	Candidate Coatings and Materials	4-2
4-2	Secondary Bonded Solid Foil Coating	4-2
4-3	Cocured Perforated Foil Coating	4-4
4-4	Spray-and-Bake Metallic Coating	4-4
4-5	Process Screening Test Matrix	4-6
4-6	AS/3501-6 Graphite/Epoxy Process Screening Qualification Panels	4-7
4-7	Adhesive Systems Evaluated for Use With Solid Foil Coating	4-7
4-8	Secondary Bonded Foil Adhesive Selection - Impact Tests	4-9
4-9	Secondary Bonded Foil Adhesive Selection - Peel Tests	4-9
4-10	Cocured Perforated Foil-Prebleeding Evaluation	4-11
4-11	Spray-and-Bake Coating Parameters	4-14
4-12	Spray-and-Bake Coating Selection - Impact Tests	4-14
4-13	Spray-and-Bake Coating Selection - Humidity Tests	4-16
4-14	Humidity Exposure of Foil and Alumazite Z-Coated Specimens for Humidity and Thermal Spiking Moisture-Resistance Tests	4-17
4-15	Bare and Solid-Foil-Coated Graphite/Epoxy Humidity Exposure Test Specimens	4-18
4-16	Cocured Foil Coated Graphite/Epoxy Humidity Exposure Test Specimens	4-18
4-17	Relative Coating Effectiveness in Moisture Penetration Under Humidity Exposure (6 X 6 In. Panels).	4-19
4-18	Effect of Foil Corrosion on Moisture Pickup of Foil-Coated Graphite/Epoxy	4-21
4-19	Effect of Size on Moisture Pickup of Solid-Foil-Coated Graphite/Epoxy	4-22
4-20	Effect of Size on Moisture Pickup of Cocured Foil-Coated Graphite/Epoxy . .	4-23
4-21	Effect of Size on Moisture Pickup of Alumazite Z-Coated Graphite/Epoxy . .	4-24
4-22	Relative Coating Effectiveness in Moisture Penetration Under Thermal Spiking Exposure (6 X 6 In. Panels)	4-25

ILLUSTRATIONS (contd)

<u>Figure</u>		<u>Page</u>
4-23	Relative Effects of Moisture Penetration of Bare Graphite/Epoxy Under Humidity and Thermal Spiking Exposure	4-27
4-24	Results of Foil- and Metal-Filled Resin-Coated Graphite/Epoxy (AS/3501-6) - Moisture Resistance Coating Selection Tests	4-28
4-25	Coating Selection - Flexural Stress (260° F) as Percent of Unexposed Strength	4-29
4-26	Coating Selection - Horizontal Shear Strength (260° F) as Percent of Unexposed Strength	4-31
4-27	Peel Strength, Foil-Coated Graphite/Epoxy	4-32
4-28	Design of Peel Strength Test Specimens	4-32
5-1	Serviceability Test Matrix	5-3
5-2	Effect of Paint Protection on Moisture Pickup of Solid-Foil-Coated Graphite/Epoxy	5-4
5-3	Effect of Paint Protection on Moisture Pickup of Bare Graphite/Epoxy	5-5
5-4	Effect of Paint Protection on Moisture Pickup of Alumazite Z-Coated Graphite/Epoxy	5-7
5-5	Effect of Paint Protection on Moisture Pickup of Thermally Spiked Solid Foil-Coated Graphite/Epoxy	5-8
5-6	Effect of Paint Protection on Moisture Pickup of Thermally Spiked Alumazite Z-Coated Graphite/Epoxy	5-9
5-7	Results of Foil- and Metal-Filled Resin-Coated Graphite/Epoxy (AS/3501-6) - Serviceability Tests	5-10
5-8	Coating Serviceability Evaluation - Flexural Stress (260° F) as Percent of Unexposed Strength	5-11
5-9	Coating Serviceability Evaluation - Horizontal Shear Strength (260° F) as Percent of Unexposed Strength	5-12
5-10	Coating Serviceability - Summary of Bending Fatigue Data (R = -1)	5-13
5-11	Drilling and Countersinking Evaluation - Painted Foil-Coated and Alumazite Z-Coated Graphite/Epoxy	5-15
5-12	Radial Sawing Evaluation: Painted Foil-Coated and Alumazite Z-Coated Graphite/Epoxy	5-16
5-13	EMI Shielding Effectiveness of Solid-Foil-Coated and Alumazite Z-Coated Graphite/Epoxy	5-18
5-14	Effect of Thermal Spiking on EMI Shielding Effectiveness of Solid Foil-Coated Graphite/Epoxy	5-19
5-15	Effect of Thermal Spiking on EMI Shielding Effectiveness of Alumazite Z-Coated Graphite/Epoxy	5-20

ILLUSTRATIONS (contd)

<u>Figure</u>		<u>Page</u>
5-16	Photomicrograph Analysis of Foil-Coated Specimens After Seven-Day Scribe Salt-Spray Exposure (200X)	5-22
A-1	Variable Impact Tester	A-3
A-2	Bell Method Peel Test Setup.	A-4
A-3	Floating Roller Peel Test Configuration	A-6
A-4	Specimen/Test Configurations	A-6
A-5	EMI Shielding Effectiveness Facility	A-8
A-6	Shielding Effectiveness Measurement Set-Up	A-9
A-7	Shielding Effectiveness Measurement Equipment	A-11
A-8	EMI Test Panel With Edge Treatment	A-11

Section 1

INTRODUCTION

1.1 BACKGROUND

Aircraft designed for optimum performance in a wide variety of hostile environments require extensive use of light-weight, durable and high-strength materials. As a result, advanced composites are being implemented extensively on high-performance aircraft. Utilization of advanced composite structures to their design limits necessitates the protection of these structures against the strength-degrading effects of moisture. Properly applied metallic coatings can not only prevent moisture absorption but also improve conductivity for better shielding effectiveness against penetration of electromagnetic energy, reduce the damaging effects of lightning strikes, and provide protection against paint strippers during aircraft refinishing operations.

1.2 OBJECTIVES

The objectives of this program were to develop metallic protective coating systems for graphite/epoxy structures and to demonstrate the environmental resistance and serviceability of those coatings against moisture penetration, electromagnetic interference, paint strippers and lightning strikes.

1.3 APPROACH

Three types of metallic protective coatings were applied to test panels fabricated from Hercules AS/3501-6 graphite/epoxy prepregged tape. These coatings include:

- Solid aluminum foil bonded in a secondary operation to cured graphite/epoxy laminates
- Perforated aluminum foil cocured with prebled graphite/epoxy laminates
- Spray-and-bake, metal-filled organic coatings applied to cured graphite/epoxy laminates.

The coated test panels were exposed to humidity (98% relative humidity at 140°F) and thermal spiking (260°F). Unexposed and exposed panels were tested to determine coating adhesion, moisture content, flexural strength and modulus, interlaminar shear strength and impact resistance. Based on the results of these tests, selected coating systems (solid

aluminum foil and Alumazite Z/spray-and-bake) were evaluated under unexposed and exposed conditions for their compatibility with Navy paint and stripper systems, electromagnetic shielding, machining, and resistance to reversed bending fatigue. Coated samples of each system have been returned to the Navy for lightning strike tests and evaluation.

Section 2

CONCLUSIONS AND RECOMMENDATIONS

2.1 CONCLUSIONS

- Aluminum foil coatings can be applied to graphite/epoxy laminates by cocuring using perforated foil with a film adhesive and by secondary bonding using solid foil with a film adhesive. The characteristics of the resulting foil coatings include good impact resistance, peel strength, and moisture protection characteristics.
- Cocuring procedures for perforated foil-coated laminates involve prebleeding of the laminate, application of a film adhesive and the foil to the laminate, and cocuring the system. Specific procedures were developed for cocuring of 18-ply laminates with perforated foil having a 0.1% open area.
- The strength-degrading effect of moisture penetration resulting from 90-day humidity exposure at 140°F and 98% relative humidity of AS/3501-6 graphite/epoxy laminates is reduced by protection of the composite with a foil coating of secondary bonded solid foil or cocured perforated foil. The reduction in 260°F flexural strength of the unprotected composite was 44%; no reduction in flexural strength was observed in specimens protected with solid or cocured foil. The reduction in 260°F horizontal shear strength of the unprotected composite was 51%; the loss in shear strength of the solid foil-coated laminate was 17%; while that of the cocured foil coated laminate was only 10 percent.
- Strength-degrading moisture penetration, resulting from exposure of AS/3501-6 graphite/epoxy composites to 40 cycles of humidity-thermal spiking conditions (3 days at 140°F and 98% relative humidity followed by 2 hours at 260°F), was reduced by using foil as a protective coating for the composite. The reduction in 260°F flexural strength of the unprotected composite was 49% compared to a 26% strength reduction in the cocured foil coated laminate (no improvement was provided by the solid foil coating). The reduction in 260°F horizontal shear strength of the unprotected composite was 56% compared to 31% for the solid foil-coated laminate and 17% for the cocured foil-coated laminate.

- Painted, solid foil-coated laminates provide increased protection from the strength degrading effects of humidity and humidity-thermal spiking over that obtained through the foil coating alone. An epoxy-polyurethane paint system was used in conjunction with the solid-foil coating to protect AS/3501-6 graphite/epoxy composites. No loss of 260°F flexural or horizontal shear strength was observed following 90-day humidity exposure or 25 thermal spiking cycles of the painted foil coated laminates.
- Fully reversed bending fatigue testing performed as end-loaded cantilever (constrained) beams at stresses ranging from 60 to 90 KSI showed that the solid-foil coating tended to hold the +45 and -45 degree surface plies of the laminate together, allowing the sample to sustain a greater number of fatigue cycles than uncoated AS/3501-6 graphite/epoxy specimens.
- AS/3501-6 graphite/epoxy laminates showed an 18% reduction in 260°F flexural strength and a 2% reduction in horizontal shear strength due to the effect of paint stripper. This loss was prevented by protection of the composite with the solid-foil coating.
- The EMI shielding effectiveness of 18-ply graphite/epoxy laminates is significantly improved by coating both sides with 0.002-inch-thick solid foil. Improvements greater than 30% in E-field, 150% in H-field, and 55% in plane wave-field shielding were observed. The effect of thermal spiking exposure on EMI shielding of foil-coated laminates varied with frequency and field type; the overall effect was a slight decrease in shielding effectiveness when compared to unexposed foil-coated laminates.
- Metal-filled resin coatings (Alumazite Z) provide protection against strength loss of AS/3501-6 graphite/epoxy laminates resulting from paint stripper attack but are not resistant to moisture penetration.
- Metal-filled resin coatings (Alumazite Z) have no significant effect on the EMI shielding effectiveness of 18-ply graphite/epoxy laminates.
- Drilling tests performed on foil-coated and Alumazite Z-coated AS/3501-6 graphite/epoxy 18-ply laminates required backup material to prevent hole breakout and demonstrated that lower drilling speeds (6000 rpm) produced better holes than higher speeds (21,000 rpm) for foil-coated laminates. Humidity exposure had no effect on the quality of holes drilled at 6000 rpm.

- Radial cutting tests showed that an 80 to 100-grit diamond blade produced good quality cuts at feed rates of 21 to 55 ipm for both humidity-exposed and unconditioned foil-coated and Alumazite Z-coated AS/3501-6 graphite/epoxy.

2.2 RECOMMENDATIONS

Analysis of the results of the work performed under this program, as well as those of internal IR&D efforts, have shown the need for further development in the following areas:

- Manufacturing procedures should be developed for shop application of protective coatings to production hardware
- Perforated aluminum foil applied by secondary bonding should be evaluated to supplement the current results obtained through the use of cocured perforated foil as a moisture protective coating system
- The environmental compatibility of the protective metallic coating systems with graphite/epoxy substrates should be demonstrated through evaluation of corrosion-inhibiting systems under sulfur dioxide/salt spray conditions
- Additional materials and/or improved processes, including pressed-powder bond coating and cold-powder spray bonding, should be evaluated for application as protective metal coatings to augment present systems
- Procedures for repair of damaged metallic coatings on graphite/epoxy substrates should be developed
- Additional cutting, drilling, reaming and countersinking techniques for metallic-coated graphite/epoxy laminates should be developed.

Section 3

PANEL FABRICATION AND CONTROL TESTING

3.1 APPROACH

This phase of the program was directed toward the fabrication techniques used throughout the test program and material qualification of the AS/3501-6 graphite/epoxy tape used. The approach involved fabrication and testing of unidirectional laminates at various bleeder ratios for material qualification and bleeder prove-out.

3.2 STUDY AREAS

Study areas involved in the fabrication and testing of the material qualification and bleeder prove-out test panels included:

- Material properties
- Fabrication techniques
- Control testing.

3.3 MATERIAL PROPERTIES

All graphite/epoxy specimens were prepared using AS/3501-6 graphite/epoxy pre-impregnated tape supplied by Hercules, Inc. This material was an amine-cured epoxy resin reinforced with unidirectional graphite fibers. Material properties are shown in Figure 3-1. Style 116 fiberglass cloth was used as the bleeder.

3.4 FABRICATION TECHNIQUES

Fabrication of unidirectional material qualification and bleeder prove-out panels, and multidirectional major process screening test panels, was conducted in accordance with established procedures. Eight- and 15-ply unidirectional laminates were fabricated for material qualification and bleeder prove-out evaluation. Major test panels fabricated for process screening and serviceability evaluation were 18-ply thick with a ply orientation of (+45, -45, 0, 0, 90, 0, 0, +45, -45)_S. The panels were cured using the following cycle:

- Place vacuum-bagged laminate in autoclave
- Pressure check autoclave system
- Apply minimum vacuum of 25 inches of mercury

PROPERTY	TYPICAL RANGE
WIDTH, IN.	3.000 ± 0.030
CURED PLY THICKNESS, MILS	5.2 ± 0.3
LENGTH/UNIT WT, FT/LB	80
RESIN CONTENT, WT%	42 ± 3
FLOW, WT%	25 ± 10
GEL TIME, MINUTES AT 350° F	10 ± 3
VOLATILES, WT%	1% MAXIMUM
TACK, MINUTES	30 MINIMUM
WORK LIFE	7 DAYS AT 75 ± 5° F, 40% RH, EXPOSED 14 DAYS AT 75 ± 5° F, 50% RH SEALED
STORAGE LIFE	3 MONTHS AT 40° F 6 MONTHS AT 0° F

0166-001B

Figure 3-1 Physical Characteristics of AS/3501-6 Graphite/Epoxy Tape (Hercules Procedure HD-SG-2-6006)

UNIDIRECTIONAL LAMINATE PLYS	BLEEDER PLYS	BLEEDER RATIO	TEST TEMP(° F)	TENSION		FLEXURAL		HORIZONTAL SHEAR STRENGTH (KSI)
				STRENGTH (KSI)	MODULUS (MSI)	STRENGTH (KSI)	MODULUS (MSI)	
8	3	2.7:1	73	223.3	19.2	—	—	—
8	4	2:1	73	206.4	19.3	—	—	—
15	5	3:1	73	—	—	241.8	14.6	15.9
15	6	2.5:1	73	—	—	249.1	15.4	15.6
15	5	3:1	260	—	—	214.4	14.9	10.3
15	6	2.5:1	260	—	—	220.5	15.2	10.8

0166-002B

Figure 3-2 AS/3501-6 Graphite/Epoxy Material Qualification and Bleeder Prove-out

- Raise the laminate temperature to $350^{\circ}\text{F} \pm 5^{\circ}\text{F}$ at a rate of $3 - 5^{\circ}\text{F}/\text{minute}$. Apply a pressure of 85 psi (+10, -0 psi) when the laminate reaches a temperature of $275^{\circ}\text{F} \pm 5^{\circ}\text{F}$
- Hold the above conditions ($350^{\circ}\text{F} \pm 5^{\circ}\text{F}$, 85 psi (+10, -0 psi) and 25 inches Hg) for 120 ± 5 minutes
- Cool the laminate to a temperature of 150°F (maximum) in 40 minutes (minimum)
- Release autoclave vacuum and pressure
- Remove laminate from autoclave
- Remove bleeder pack
- Post-cure laminate for 8 hours at 350°F in an air-circulating oven.

All tooling and caul plates were cleaned, coated with Frekote 33 and baked at 350°F for one hour prior to use. Panels were cured with one ply of peel ply on each side of the laminate. Thermocouples were used to monitor the autoclave cycle.

The procedure used for fabrication of the cocured perforated-foil-coated laminates is discussed in Section 4. Development of a prebleeding procedure was necessary to obtain the optimum properties for the cocured laminates.

3.5 CONTROL TESTING

Material qualification and bleeder prove-out panels were fabricated from Hercules AS/3501-6 graphite/epoxy tape. Two, 3 x 10 inch, 8-ply unidirectional panels for tensile strength specimens were fabricated using prepregged tape-to-bleeder ratios of 2.0 to 1.0 and 2.7 to 1.0. Two, 3 x 10-inch, 15-ply unidirectional panels for flexural and interlaminar shear strength specimens were fabricated using 2.5 to 1.0 and 3.0 to 1.0 prepregged tape-to-bleeder ratios. Test specimens were cut from the cured panels with a diamond saw and subjected to tensile tests at room temperature (73°F) and flexural and interlaminar shear strength tests at room temperature (73°F) and at 260°F . The results are shown in Figure 3-2. Selection of a 2.5 to 1.0 ratio of prepregged tape-to-bleeder plies was based on the results of these tests. This bleeder ratio was used for fabrication of all major test panels for process screening and serviceability evaluation except the cocured perforated-foil-coated laminates. The bleeder system required for prebleeding and curing these laminates is discussed in Section 4.

Section 4

PROCESS SCREENING EVALUATION

4.1 APPROACH

This phase of the program was concerned with evaluation and development of various candidate coating systems. The approach involved development of application parameters for each of the candidate coatings and evaluation of the coating performance with respect to impact resistance, adhesion, and moisture resistance.

4.2 STUDY AREAS

Evaluation and development of candidate coatings for process screening involved the following:

- Candidate coatings and materials selection
- Development of application parameters for candidate coatings
- Evaluation of moisture resistance.

4.3 BACKGROUND

Previous Grumman studies have shown that organic coatings do not provide the moisture barrier needed to protect graphite/epoxy components from critical strength-degrading moisture absorption. These studies, together with the need for electrical conductivity to provide protection against lightning strikes and electromagnetic interference (EMI), led to the decision to evaluate metallic coatings.

4.4 CANDIDATE COATINGS AND MATERIALS

The metallic coatings selected for preliminary evaluation included aluminum foil, applied by secondary bonding to the graphite/epoxy laminate and by cocuring of the foil with the laminate, and a metal-filled resin coating, applied by a spray-and-bake process. Materials used in these coatings are summarized in Figure 4-1.

COATINGS EVALUATED	TYPE	DESCRIPTION
ALUMINUM FOIL- SECONDARY BONDED	0.002-IN. 2024-T3 SOLID ALUMINUM FOIL	<ul style="list-style-type: none"> DENSIL 2078-PRESSURE SENSITIVE SILICONE FILM ADHESIVE (DENNISON MANUFACTURING COMPANY), RT CURE DEXTER HYSOL 9628-0.010 LB/FT² EPOXY FILM ADHESIVE (HYSOL DIVISION, DEXTER CORP.), 300° F/15 MIN DEXTER HYSOL 9628-BRUSH OR SPRAY EPOXY ADHESIVE (HYSOL DIVISION, DEXTER CORP.), 300° F/15 MIN COMBINATION-DEXTER HYSOL 9628 FILM (ABOVE) WITH DUPONT 6870 BRUSH OR SPRAY ACRYLIC (DUPONT CORP.), 300° F/15 MIN
ALUMINUM FOIL- COCURED	<ul style="list-style-type: none"> TOP-0.003-IN. 5056 PERFORATED ALUMINUM FOIL 0.005-IN.-DIA HOLES, 40 HOLES /SQ IN. BOTTOM-0.002-IN. 2024-T3 SOLID ALUMINUM FOIL 	<ul style="list-style-type: none"> 104 SCRIM – 1-MIL GLASS FABRIC PREPREG SCRIM DEXTER HYSOL 9628-0.010 LB/FT² EPOXY FILM ADHESIVE (HYSOL DIVISION, DEXTER CORP.), 300° F/15 MIN
SPRAY-AND-BAKE METAL-FILLED RESIN	<ul style="list-style-type: none"> ALUMAZITE Z, CLASS 3 ALUMAZITE Z, CLASS 3FS KERIMID 500, ALUMINUM FILLED 	ALUMINUM FILLED (375° F/1 HR) (TIODIZE COMPANY, INC.) ALUMINUM/SILVER FILLED (375° F/1 HR) (TIODIZE COMPANY, INC.) POLYAMIDE-IMIDE (RHODIA, INC.) (400° F/1 HR) WITH ALUMINUM FILLER

0166-003B

Figure 4-1 Candidate Coatings and Materials

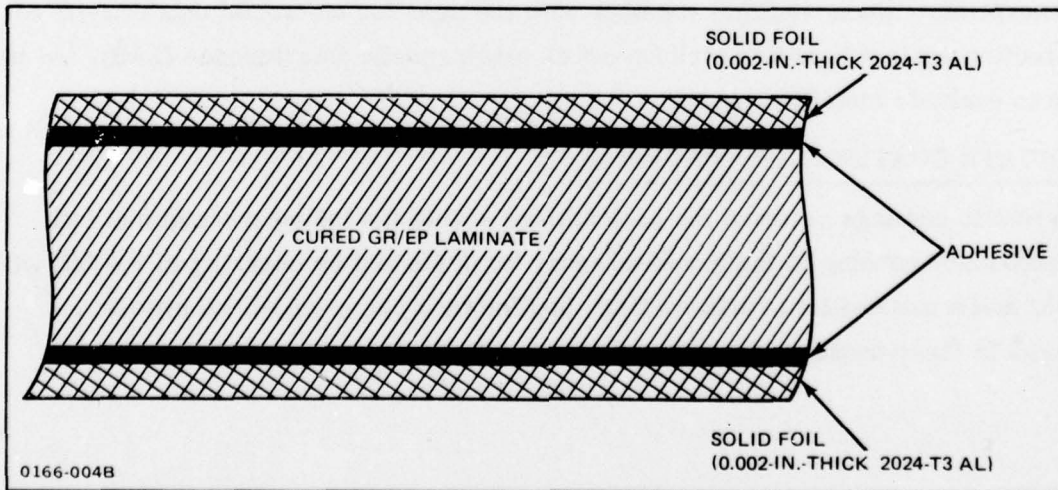

0166-004B

Figure. 4-2 Secondary Bonded Solid Foil Coating

4.4.1 Aluminum Foil - Secondary Bonded

Aluminum foil bonded to the cured graphite/epoxy laminate, using an appropriate adhesive, was considered as a potential moisture barrier coating for graphite/epoxy composites (Figure 4-2). The aluminum foil material selected for this coating was 0.002-inch-thick 2024-T3 aluminum alloy. The foil was primed and pretreated prior to bonding. The following adhesive systems were evaluated for use with this coating:

- Densil 2078 - pressure-sensitive silicone film adhesive (Dennison Manufacturing Company)
- Dexter Hysol 9628 - 0.010 lb/ft² epoxy film adhesive (Hysol Division of the Dexter Corporation)
- Dexter Hysol 9628 - brush or spray epoxy adhesive (Hysol Division of the Dexter Corporation)
- Combination - Dexter Hysol 9628 film (above) with DuPont 6870 brush or spray acrylic (DuPont Corporation).

Densil 2078 is a pressure-sensitive silicone adhesive which develops maximum strength after aging for three days at room temperature. The other adhesives required an elevated-temperature cure; they were cured at 300° F for 15 minutes under vacuum.

4.4.2 Cocured Aluminum Foil

Aluminum foil, cocured with the graphite/epoxy laminate to provide an integrally bonded coating, was evaluated as a candidate system for the protection of graphite/epoxy components from moisture penetration (Figure 4-3). A perforated foil was selected for this coating to allow for resin bleedout during the curing operation. A 0.003-inch-thick 5056 aluminum alloy foil, perforated with 0.005-inch-diameter holes at 40 holes per square inch, was used for the top side of the laminate. Solid, 0.002-inch-thick, 2024-T3 aluminum alloy foil was used for the bottom surface of the laminate to force resin bleedout through the top foil. The adhesive systems evaluated for the cocured foil included preimpregnated 104 scrim cloth (1-mil glass fabric) and 0.010 lb/ft² Dexter Hysol 9628 epoxy film adhesive.

4.4.3 Spray-and-Bake Metallic Coatings

Three metal-filled resin coatings were evaluated as potential moisture barrier coatings for graphite/epoxy laminates (Figure 4-4). These spray-and-bake coating systems were:

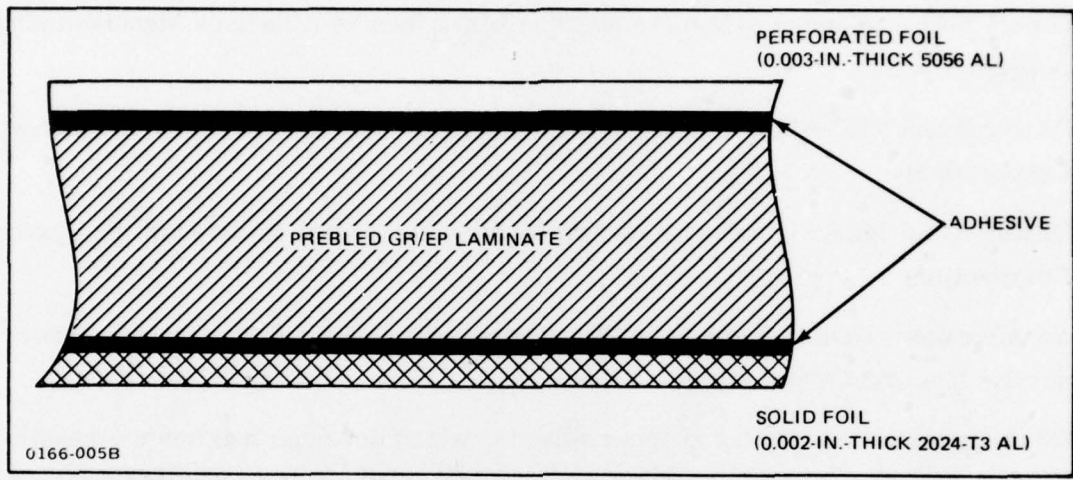

Figure 4-3 Cocured Perforated Foil Coating

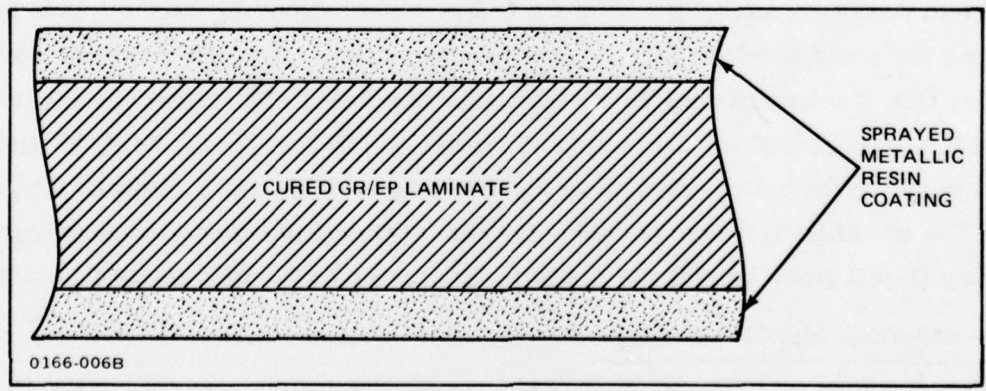

Figure 4-4 Spray-and-Bake Metallic Coating

- Alumazite Z, Class 3, aluminum-filled (Tiodize Company, Inc.)
- Alumazite Z, Class 3FS, aluminum/silver-filled (Tiodize Company, Inc.)
- Kerimid 500 polyamide-imide (Rhodia, Inc.) with aluminum filler.

The Alumazite Z coatings were cured for one hour at 375°F and the Kerimid 500 coating for one hour at 400°F.

4.5 DEVELOPMENT OF APPLICATION PARAMETERS

4.5.1 Secondary Bonded Aluminum Foil

Graphite/epoxy laminates, coated with solid aluminum foil, were prepared by applying the foil to cured laminates in a secondary bonding operation. Parameters requiring development for this operation included foil pretreatment and adhesive selection.

4.5.1.1 Laminates

Major process screening test panels of 18-ply AS/3501-6 graphite/epoxy were prepared, using the same procedure described in Section 3 for preparation of the material qualification and bleeder prove-out test panels. A fiber orientation of (+45, -45, 0, 0, 90, 0, 0, +45, -45)_g was used. Ultrasonic scanning showed that all panels were satisfactory. The panels were cut with a diamond saw to give the subpanel sizes shown in Figure 4-5. Flexural and horizontal shear strengths were established to determine the acceptability of these panels for environmental conditioning evaluation. The results of these tests are shown in Figure 4-6.

4.5.1.2 Foil and Pretreatment

The material used for the secondary bonded aluminum foil coating was 0.002-inch-thick 2024-T3 aluminum alloy foil. The foil pretreatment consisted of vapor degreasing, alkaline cleaning with Oakite 164 followed by acid cleaning with sulfuric acid-sodium dichromate solution. Following pretreatment, the foil was primed with EC-2333 silane primer.

4.5.1.3 Adhesive Selection

The foil was bonded to the cured graphite/epoxy laminate, using one of several adhesives (Figure 4-7). Evaluation of the various adhesives was made by determination of the impact resistance and peel strength of the bonded foil coating. The foil was bonded in an autoclave simulator under full vacuum (28 inches Hg) at 300°F and 85 psi for 15 minutes.

	MAJOR PANELS FOR ULTRASONIC SCANNING (IN.)	SUB-PANEL SIZES (IN.)	NUMBER OF SAMPLES							PHOTO-MICRO ANALYSIS (IN.)		
			FLEXURAL STRENGTH 73° F 260° F	INTER-LAMINAR SHEAR STRENGTH 73° F 260° F	ROLLER PEEL STRENGTH 73° F	DROP BALL IMPACT 73° F	MOISTURE PICKUP 140° F/98% RH	REVERSED BENDING 73° F	TENSILE STRENGTH 73° F			
TECHNICAL EFFORT												
PHASE II - PROCESS SCREENING ALUMINUM FOIL												
• ADHESIVE SELECTION	18.5 X 23.5	(6) 8.5 X 10.5			18		36					
• OPTIMUM ADHESIVE TESTING (CONTROL, HUMIDITY, THERMAL SPIKING)	21 X 21	(3) 6 X 14 (4) 2 X 4	9	9	15		4					
• COCURED EVALUATION (CONTROL, HUMIDITY, THERMAL SPIKING)	21 X 21	(3) 6 X 14 (4) 2 X 4	9	9	15		4					6
• OPTIMUM FOIL COATING (HUMIDITY, THERMAL SPIKING)	9.5 X 12	(2) 4.75 X 12								6		3
SPRAY-AND-BAKE COATING												
• COATING SELECTION	6.25 X 20.5	(3) 3 X 6 (4) 2 X 4					24					
• OPTIMUM SPRAY-AND-BAKE TESTING (CONTROL, HUMIDITY, SPIKING)	21.25 X 23.5 9.5 X 12	(4) 9.5 X 10.5 (2) 4.75 X 12	12	12	20		6					6 3
0166-007B												

Figure 4-5 Process Screening Test Matrix

PROPERTY	LAMINATE PLIES*	BLEEDER PLIES***	TEST TEMPERATURE(°F)	TEST RESULTS**
FLEXURAL STRENGTH (KSI)	18	7	73	160.9
	18	7	260	153.4
FLEXURAL MODULUS (MSI)	18	7	73	7.70
	18	7	260	7.55
HORIZONTAL SHEAR STRENGTH (KSI)	18	7	73	10.60
	18	7	260	8.15
*ORIENTATION - (+45, -45, 0, 0, 90, 0, 0, +45, -45) **AVERAGE OF FOUR TESTS ***116 GLASS CLOTH				

0166-008B

Figure 4-6 AS/3501-6 Graphite/Epoxy Process Screening Qualification Panels

ADHESIVE	SUPPLIER	ADHESIVE TYPE	RESIN TYPE	THICKNESS (IN.)	CURE CYCLE	
					TEMP (°F)	TIME (HR)
DENSIL 2078	DENNISON MFG. CO.	PRESSURE SENSITIVE	SILICONE	0.0065	73	72**
DEXTER HYSOL 9628 FILM	HYSOL DIV., DEXTER CORP.	FILM	EPOXY	0.002	300	0.25
DEXTER HYSOL 9628 SPRAY	HYSOL DIV., DEXTER CORP.	BRUSH OR SPRAY	EPOXY	-	300	0.25
DUPONT 6870*	DUPONT CORP.	BRUSH OR SPRAY	ACRYLIC	-	300	0.25
*DUPONT 6870 WAS USED IN CONJUNCTION WITH DEXTER HYSOL 9628 FILM. **TIME TO DEVELOP MAXIMUM BOND STRENGTH.						

0166-009B

Figure 4-7 Adhesive Systems Evaluated for Use With Solid Foil Coating

Impact tests were conducted for each of the four adhesive systems in accordance with ASTM Test Method No. D2794 (Appendix A). Foil-coated composite specimens, subjected to point impact loads, were evaluated to determine the effect of impact on the coating. The impact resistance, as determined by visible damage to the foil provided an indication of the flexibility and bond strength of each of the adhesives evaluated. The impact force at which a foil break occurred was used as the basis of comparison (Figure 4-8). At this point, indirect impact caused outer ply separation in the laminate. There was no visible damage of the laminate at lower impact levels. Results (Figure 4-8) indicated that Dexter Hysol 9628 film adhesive provides slightly better resistance to direct and indirect impact than the other adhesives evaluated.

The peel strength of the candidate adhesives was determined by use of the Bell roller peel strength test (Appendix A). The foil was peeled from 1-inch-wide specimens at an angle of 105 degrees and the load required to strip the foil from the restrained specimen was determined. Room-temperature tests showed that the highest peel strength was obtained from Dexter Hysol 9628 film adhesive (Figure 4-9). This adhesive was selected for all subsequent studies of the secondary bonded solid foil coating.

4.5.1.4 Laminate Preparation

The following procedure, developed during adhesive selection evaluations, was used for preparation of the secondary bonded solid foil-coated laminates:

- Layup, cure, and post-cure 18-ply laminate (Paragraph 3.4)
- Remove peel ply
- Apply Dexter Hysol 9628 film adhesive to both sides of laminate
- Apply pretreated 0.002-inch-thick 2024-T3 solid aluminum foil to both sides of laminate
- Cure adhesive at 300°F, 85 psi and full vacuum for 15 minutes.

4.5.2 Cocured Aluminum Foil

Application of a foil coating to a graphite/epoxy laminate, by means of cocuring with the laminate, was accomplished in two major operations: prebleeding of the laminate and curing of the foil-coated laminate. It was necessary to develop prebleeding procedures to optimize the strength of the laminate. Selection of an adhesive capable of providing adhesion of the foil to the laminate was also required.

IMPACT STRENGTH (IN.-LB)	DENSIL 2078		DEXTER HYSOL 9628 (FILM) WITH DUPONT 6870		DEXTER HYSOL 9628 (FILM)		DEXTER HYSOL 9628 (SPRAY)	
	DIRECT	INDIRECT	DIRECT	INDIRECT	DIRECT	INDIRECT	DIRECT	INDIRECT
10								
20								
30								
40		FOIL BREAK						FOIL BREAK
50				FOIL BREAK		FOIL BREAK		
60	FOIL BREAK		FOIL BREAK					
70					*		*	
*NO FOIL BREAK								

0166-010B

Figure 4-8 Secondary Bonded Solid Foil Adhesive Selection – Impact Tests

ADHESIVE SYSTEM	AVERAGE PEEL STRENGTH* (LBS/IN.)	MODE OF FAILURE
DENSIL 2078	4.8	90% ADHESIVE-GRAPHITE 10% ADHESIVE-FOIL
DEXTER HYSOL 9628 (FILM)	18.2	100% COHESIVE
DEXTER HYSOL 9628 (SPRAY)	4.4	100% COHESIVE
DEXTER HYSOL 9628 (FILM) WITH DUPONT 6870	14.9	100% COHESIVE
*AVERAGE OF THREE TO SIX TESTS.		

0166-011B

Figure 4-9 Secondary Bonded Solid Foil Adhesive Selection – Peel Tests

4.5.2.1 Foil and Pretreatment

The foil selected for this application included perforations to allow for resin bleedout during the final cure. The perforated foil used was 0.003-inch thick 5056 aluminum foil with 0.005-inch diameter holes at 40 holes per square inch. This foil was pretreated by vapor degreasing, alkaline cleaning with Oakite 164, and acid cleaning with sulfuric acid-sodium dichromate solution. Solid foil was applied to the bottom of the laminate because resin bleedout took place only through the top. The solid foil and associated pretreatment used for this application was the same as that used for the secondary bonded foil coating.

4.5.2.2 Prebleeding Procedure

Prebleeding procedures were developed since only limited resin bleedout could be achieved through the perforated foil during the final curing. Development efforts were initially directed toward obtaining a total resin bleedout of 10% by adjusting the prebleed cycle. The target thickness for the 18-ply laminates after prebleed was 0.092 to 0.097 inch. The bleeder type, number of bleeder plies used, and the prebleed cycle were varied in the initial tests (Panels A through F, Figure 4-10), in an effort to obtain the target resin bleedout and thickness and to provide good flexural and horizontal shear strength values.

Panels A, B1, B2 and C1, which were prebled at 200°F for 30 minutes, were thicker than the target value after prebleed (0.110 to 0.120 inch vs target value of 0.092 to 0.097 inch). The total resin removal for Panel A, which was final cured, was only 6%, compared to the target of 10% resin removal. By increasing the Panel C2 prebleed cycle to 230°F for 60 minutes the prebled thickness decreased to 0.101 inch and the total resin removal, after final cure, increased to the target value of 10%. An evaluation of the flexural and horizontal shear strengths showed that the strength of Panel C2 was within the expected range for an 18-ply panel of the (+45, -45, 0, 0, 90, 0, 0, +45, -45)_S fiber orientation. Similar results were obtained from a second panel (Panel D) under the same conditions used for Panel C2. A section of Panel D was post-cured for 8 hours at 350°F. Since this section (Panel DP) exhibited slightly lower strength values, none of the cocured panels were post-cured for this study.

4.5.2.3 Adhesive Selection

The foil-to-laminate bond of the initial cocured panels (A through D) was provided by the epoxy resin in the laminate. Because this bond was not sufficient for the purpose of the coating, selection of an additional adhesive was required (Figure 4-10). Two adhesives, 3M Company's SP-298 glass/epoxy 104 adhesive scrim cloth and Dexter Hysol 9628 film,

OPERATION/ RESULTS	PANEL NUMBER								
	A	B-1 & B-2 (AVG)	C-1	C-2	D	DP	E	F & RF (AVG)	G & H (AVG)
PREBLEED									
BLEEDER TYPE	116 GL	116 GL	116 GL	116 GL	116 GL/ 181 GL	SAME AS "D"	116 GL/ 181 GL	116 GL/ 181 GL	116 GL/ 181 GL
NO. OF PLYS	5	5	7	7	7/4		8/4	8/4	8/4
CYCLE - TEMP/ TIME AT TEMP (80 PSI, 30-IN. VAC)	200° F/ 30 MIN	200° F/ 30 MIN	200° F/ 30 MIN	230° F/ 60 MIN	230° F/ 60 MIN		230° F/ 70 MIN	230° F/ 70 MIN	230° F/ 70 MIN
FINAL									
BLEEDER TYPE	116 GL			NYLON PEEL PLY	NYLON PEEL PLY	SAME AS "D"	NYLON PEEL PLY	NYLON PEEL PLY	NYLON PEEL PLY
NO. OF PLYS	2			1	1		1	1	1
ADHESIVE	NONE			NONE	NONE		104 SCRIM	9628 FILM	9628 FILM
CURE CYCLE-TEMP/ TIME AT TEMP (85 PSI, 30-IN. VAC)	350° F/ 120 MIN	DID NOT FINAL CURE	DID NOT FINAL CURE	350° F/ 120 MIN	350° F/ 120 MIN	350° F/ 120 MIN	350° F/ 120 MIN	350° F/ 120 MIN	
TOTAL RESIN REMOVED (%)	6			10	13		5	11	15
PREBLEED THICK- NESS (IN.)	0.120	0.115 (TOO THICK)	0.110 (TOO THICK)	0.101	0.103	"D" POST- CURED 350° F/8 HR	0.107	0.108	0.094
ADHESION*	POOR			POOR	POOR	161.9	FAIR	GOOD	GOOD
FLEX STRESS, (KSI) RT				170.9	165.3	161.9	183.5	187.8	199.0
FLEX MOD, (MSI) RT				8.2	7.6	8.3	9.4	9.7	10.4
HORIZ SHEAR STR, (KSI) RT				9.9	10.7	8.9	11.1	11.2	10.8
0166-012B									
* POOR- EASILY PEELED OFF FAIR- MODERATE BOND GOOD- STRONG BOND (MEASURED PEEL STRENGTH: 17.5 LB/IN.)									

Fig. 4-10 Cocured Perforated Foil - Prebleeding Evaluation

were evaluated. The 104 scrim cloth improved adhesion of the foil to the laminate (Panel E), although the bond was not as good as required. Dexter Hysol 9628 film adhesive, used as the adhesive for Panels F and RF, provided a good bond of the foil to the laminate.

4.5.2.4 Finalization of Cocuring Procedure

The parameters evaluated to establish the optimum cocuring procedure for a cocured foil coating included prebleed cycle, adhesive type, post-cure requirements, and bleeder requirements. As part of the adhesive selection tests, evaluation of a longer prebleed cycle and larger bleeder pack was made. The prebleed cycle was increased from 60 to 70 minutes at 230°F. The bleeder pack consisted of eight layers of Style 116 glass cloth with 4 layers of Style 181 glass cloth. This allowed more uniform vacuum over the part and greater resin bleedout than the original bleeder pack of 5 to 7 layers of Style 116 glass cloth. As a result of these changes (Panels E, F and RF), the flexural and horizontal shear strength (properties at room temperature) were improved (Figure 4-10).

The selected conditions for each of the parameters evaluated were used in Panels G and H to verify the results obtained and finalize the cocuring conditions. These panels were prepared using fresher graphite/epoxy tape than that used for the initial panels (A through F); this was expected to improve the prebleed thickness and resin bleedout. The results obtained from Panels G and H were excellent (Figure 4-10). A total resin bleedout of 15%, with a prebled thickness of 0.094 inch, resulted in a flexural stress value of 199 KSI and a horizontal shear strength of 10.8 KSI. The bond between the foil and the laminate was also good.

The selected cocuring procedure used to prepare Panels G and H and all subsequent cocured panels was as follows:

- Layup 18 plies of AS/3501-6 graphite/epoxy tape
- Apply bleeder
 - 8 plies of Style 116 glass cloth
 - 4 plies of Style 181 glass cloth
- Prebleed at 225 - 235°F, 80 psi and full vacuum for 70 minutes
- Remove bleeder plies
- Apply Dexter Hysol 9628 film adhesive to both sides of prebled laminate
- Apply pretreated 0.002-inch-thick 2024-T3 solid aluminum foil to bottom of laminate

- Apply pretreated 0.003-inch-thick 5056 perforated aluminum foil to top of laminate
- Apply one ply of nylon peel ply
- Cure at 350°F, 85 psi and full vacuum for 2 hours.

4.5.3 Spray-and-Bake Metallic Coatings

Graphite/epoxy laminates coated with spray-and-bake metallic coatings were prepared by applying a metal-filled resin coating to a cured laminate by conventional spray techniques and curing the coating under the required conditions of time and temperature. Application parameters, including cure time and temperature, coating thickness, and metal content, varied according to the coating system used.

4.5.3.1 Laminates

Major process screening panels, which were prepared for the evaluation, were sectioned into the test panels indicated in Figure 4-5. These panels were 18-ply AS/3501-6 graphite/epoxy laminates with a fiber orientation of (+45, -45, 0, 0, 90, 0, 0, +45, -45)_S. NDI and mechanical property evaluation showed the acceptability of the major test panels (Figure 4-6).

4.5.3.2 Coating Application

Three spray-and-bake coatings were evaluated under this program: Alumazite Z and silver-filled Alumazite Z from Tiodize Corp. and Kerimid 500 from Rhodia, Inc. The two Alumazite Z coatings were applied as supplied. Aluminum powder was added to the Kerimid 500 to provide coating conductivity. The properties and application parameters of these coatings are shown in Figure 4-11.

4.5.3.3 Coating Selection

Evaluation of three candidate spray-and-bake coatings was based on impact resistance and moisture pickup of coated laminates. The coated laminates were subjected to point impact loads using a variable impact tester. Assessment of the damage resulting from direct and indirect impact was made at various levels (Figure 4-12). Direct impact up to 60 in/lb did not cause damage to any of the coatings or visible damage to the laminate directly under the coating. Indirect impact caused outer ply separation and coating damage at 40 in/lb on the silver-filled Alumazite Z and aluminum-filled Kerimid 500-coated laminates. Indirect impact of the Alumazite Z coated laminate caused the coating to crack at 30 in/lb. However, there was no visible damage to the laminate up to 60 in/lb. Three 2 x 4-inch

COATING	FORMULATION	CURE CONDITIONS
ALUMAZITE Z, CLASS 3, ALUMINUM FILLED	PROPRIETARY – TIODIZE CO., INC.	375° F/1 HR
ALUMAZITE Z, CLASS 3FS, ALUMINUM/SILVER FILLED	PROPRIETARY – TIODIZE CO., INC.	375° F/1 HR
KERIMID 500 WITH ALUMINUM FILLER	75% KERIMID 500, 25% ALUMINUM POWDER (EC1101-3M CO.) DILUTED WITH N-METHYLPYRROLIDONE TO SPRAYING VISCOSITY	400° F/1 HR

0166-013B

Figure 4-11 Spray-and-Bake Coating Parameters

IMPACT STRENGTH (IN. LB)	KERIMID 500 (ALUMINUM-FILLED)		ALUMAZITE Z (SILVER-FILLED)		ALUMAZITE Z	
	DIRECT	INDIRECT	DIRECT	INDIRECT	DIRECT	INDIRECT
10						
20						
30						COATING SLIGHTLY CRACKED
40		OUTER PLY SEPARATION . COATING CHIPPED		OUTER PLY SEPARATION . COATING CHIPPED		
50						
60	NO DAMAGE		NO DAMAGE		NO DAMAGE	NO PLY SEPARATION

DIRECT IMPACT

INDIRECT IMPACT

GR/EP

COATING

0166-014B

Figure 4-12 Spray-and-Bake Coating Selection – Impact Tests

graphite/epoxy panels were coated with the spray-and-bake coatings and exposed to 140°F and 98% relative humidity (RH). Periodic weight measurements were taken to determine their relative weight gain (Figure 4-13). Comparison to an uncoated graphite/epoxy panel subjected to the same conditions shows that the weight pickup of the coated panels was greater than that of the bare panel over a 90-day exposure period. This increase in weight pickup was apparently due to moisture pickup by the coatings, since no corrosion of the coatings was evident upon visual inspection. Both Alumazite Z coatings picked up less moisture than the Kerimid 500 coating during the 90-day exposure. The Alumazite Z was selected for further testing because it prevented laminate ply separation caused by indirect impact and showed slightly better performance under impact resistance and moisture pickup than the silver-filled Alumazite Z and the aluminum-filled Kerimid 500 coatings. The following Alumazite Z application procedure was used for all further test panels:

- Layup, cure, and post-cure 18-ply laminate (Paragraph 3.4)
- Remove peel ply
- Coat with Alumazite Z to 0.2 to 0.5-mil thickness, using conventional spray equipment
- Bake at 375°F ± 25°F for 1 hour.

4.6 EVALUATION OF MOISTURE RESISTANCE

The moisture resistance of the three selected coating systems (solid foil, cocured foil and Alumazite Z) was evaluated by exposing several coated panels to humidity and humidity-thermal spiking conditions (Figure 4-14). The moisture pickup and strength retention of the various coated panels were compared to assess the relative abilities of the coatings to provide the moisture protection required for the graphite/epoxy laminates.

4.6.1 Humidity Exposure

Evaluation of the moisture resistance of the selected coating systems (Figures 4-15 and 4-16) was made under a humidity exposure of 140°F and 98% RH for 90 days. Periodic weight measurements were taken and the percent weight gain determined for each of the exposed panels. A bare graphite/epoxy panel was used as the control. A comparison of the weight pickup of the three protection systems (Figure 4-17) showed that the solid foil and cocured foil coatings both provide a significant reduction in the weight pickup of the laminates compared to the bare control. More than 50% reduction in weight pickup was obtained with the solid foil coating. The cocured foil coating provided more than 65% reduction in weight pickup over the 90-day exposure period.

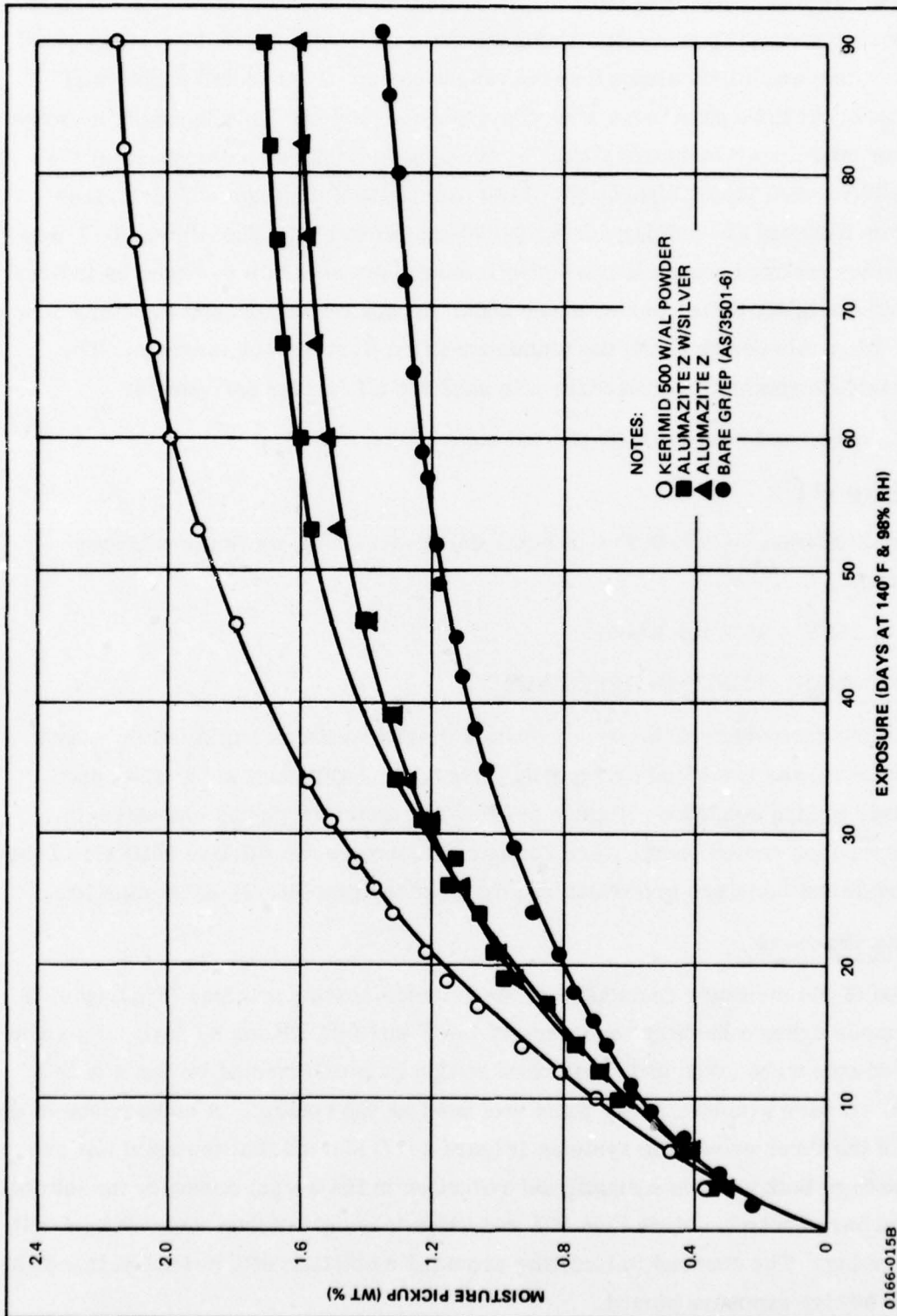

Figure 4-13 Spray-and-Bake Coating Selection - Humidity Tests



0166-016B

Figure 4-14 Humidity Exposure of Foil and Alumazite Z-Coated Specimens for Humidity and Thermal Spiking Moisture-Resistance Tests

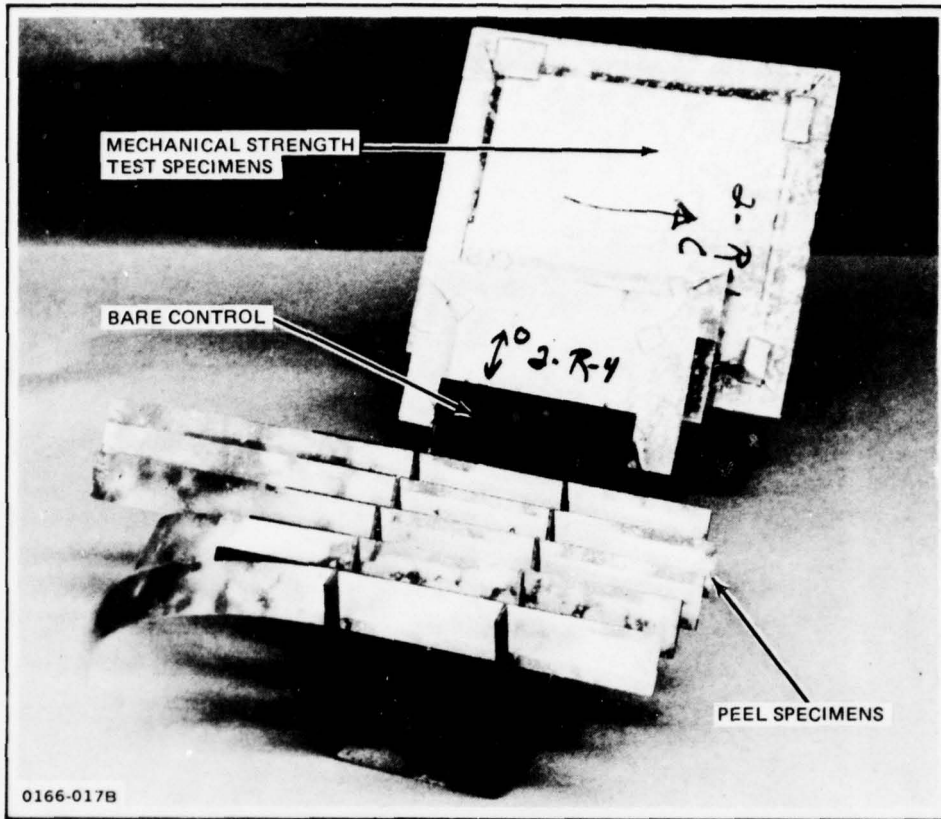

Figure 4-15 Bare and Solid-Foil-Coated Graphite/Epoxy Humidity Exposure Test Specimens

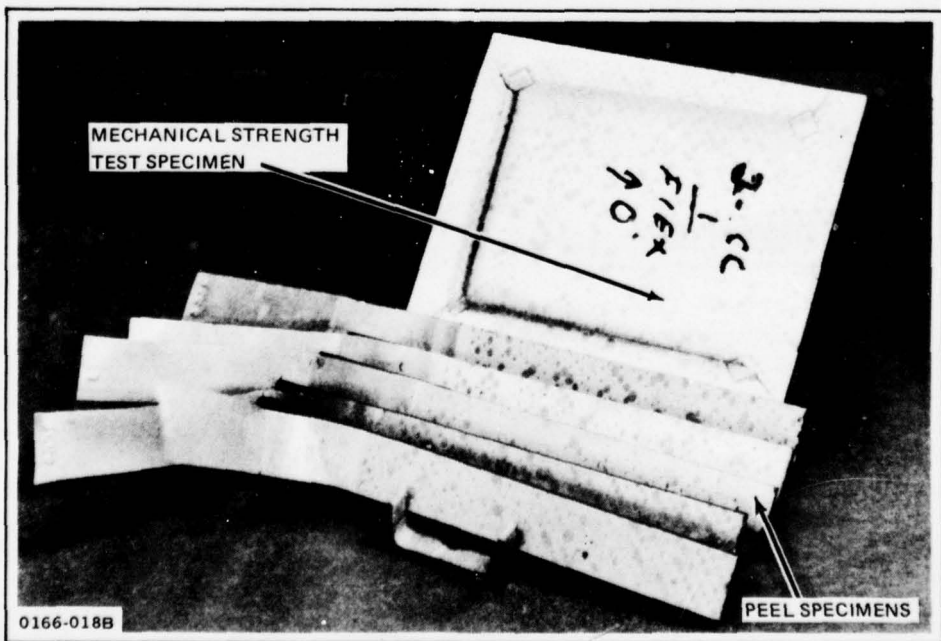

Figure 4-16 Cocured Foil-Coated Graphite/Epoxy Humidity Exposure Test Specimens

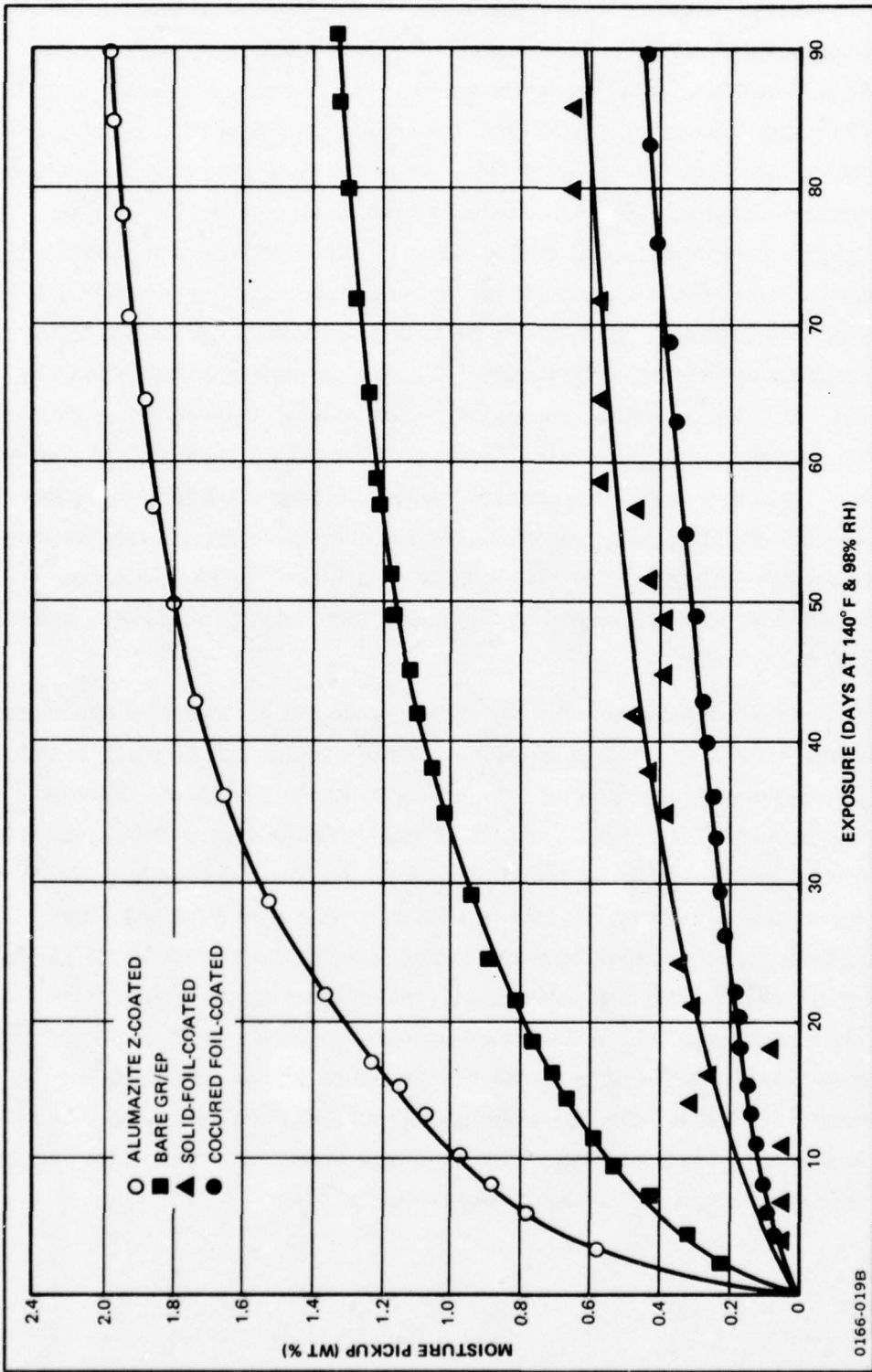

Figure 4-17 Relative Coating Effectiveness in Moisture Penetration Under Humidity Exposure (~ 6 X 6 In. Panels)

The weight pickup of coated graphite/epoxy, which had been exposed to humidity and thermal spiking, was made up, in general, of three types of weight gain. These included moisture pickup by the graphite/epoxy, moisture pickup by the coating, and corrosion of the foil coatings. These factors must be separated from the total measured weight gain to evaluate the protection which the coating provides to the composite. The total weight pickup of the Alumazite Z coated laminates was greater than that of the bare laminate, indicating that the coating absorbed moisture in addition to allowing moisture penetration into the laminate. The total weight pickup of the foil coated laminates included moisture pickup by the adhesive, for which no estimate of the weight pickup was made, and corrosion of the foil. The effect of this factor was estimated by exposing solid and perforated foil sheets to the same conditions of humidity as the coated laminates. The total weight pickup of the foil-coated specimens, corrected for the weight pickup of the foil sheets, showed the approximate moisture pickup of the graphite/epoxy laminate (Figure 4-18) for the solid foil- and cocured foil-coated specimens. This corrected moisture level could be compared directly to the moisture pickup of the bare graphite/epoxy specimen to show the moisture protection provided by the two foil coatings (Figure 4-18). The moisture pickup of the laminate was reduced by 59% using the solid foil coating and by 80% using the cocured foil coating over the 90-day humidity exposure period.

Apparent discrepancies were observed in the weight pickup of various size specimens coated with the same system and exposed to the same humidity conditions (Figures 4-19 through 4-21). Edge diffusion was the major factor contributing to this effect. Because diffusion rates were higher parallel to the fibers, the change in edge area resulting from a change in panel size had a greater effect on moisture absorption than the change in total surface area. The effect was multiplied with the foil coatings (Figures 4-19 and 4-20) because the foil effectively prevented moisture absorption through the surface of the laminate. The observed effect was smaller with the Alumazite Z-coated specimens (Figure 4-22) because the coating did not substantially reduce moisture pickup; thus, both sizes tended toward the equilibrium moisture content over the 90-day exposure period. Because the strength test specimens were taken from the larger panels and because even larger sections would be employed in actual aircraft situations, the moisture levels observed in the larger panels were considered most accurate for the purposes of this study.

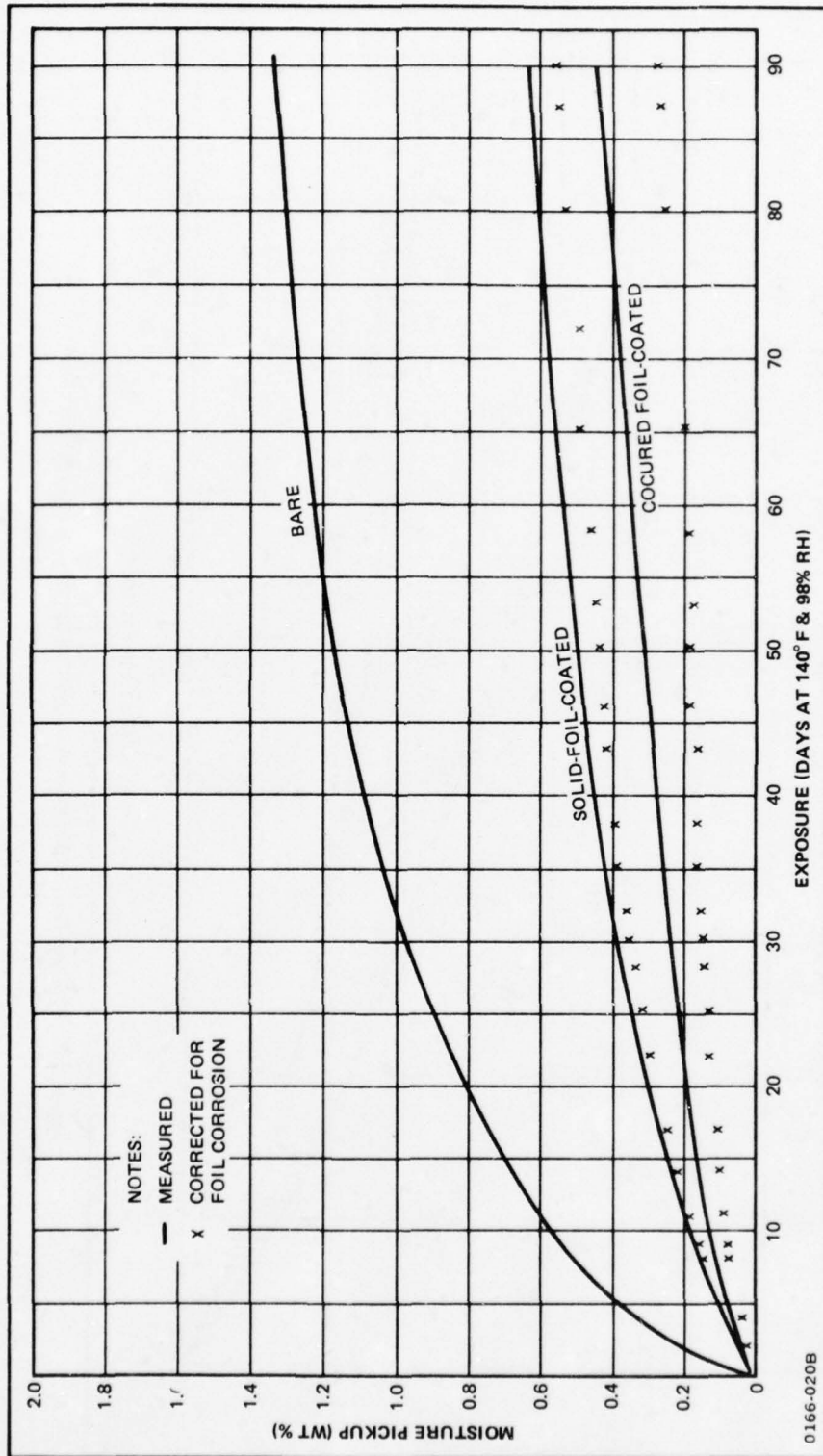

Figure 4-18 Effect of Foil Corrosion on Moisture Pickup of Foil-Coated Graphite/Epoxy

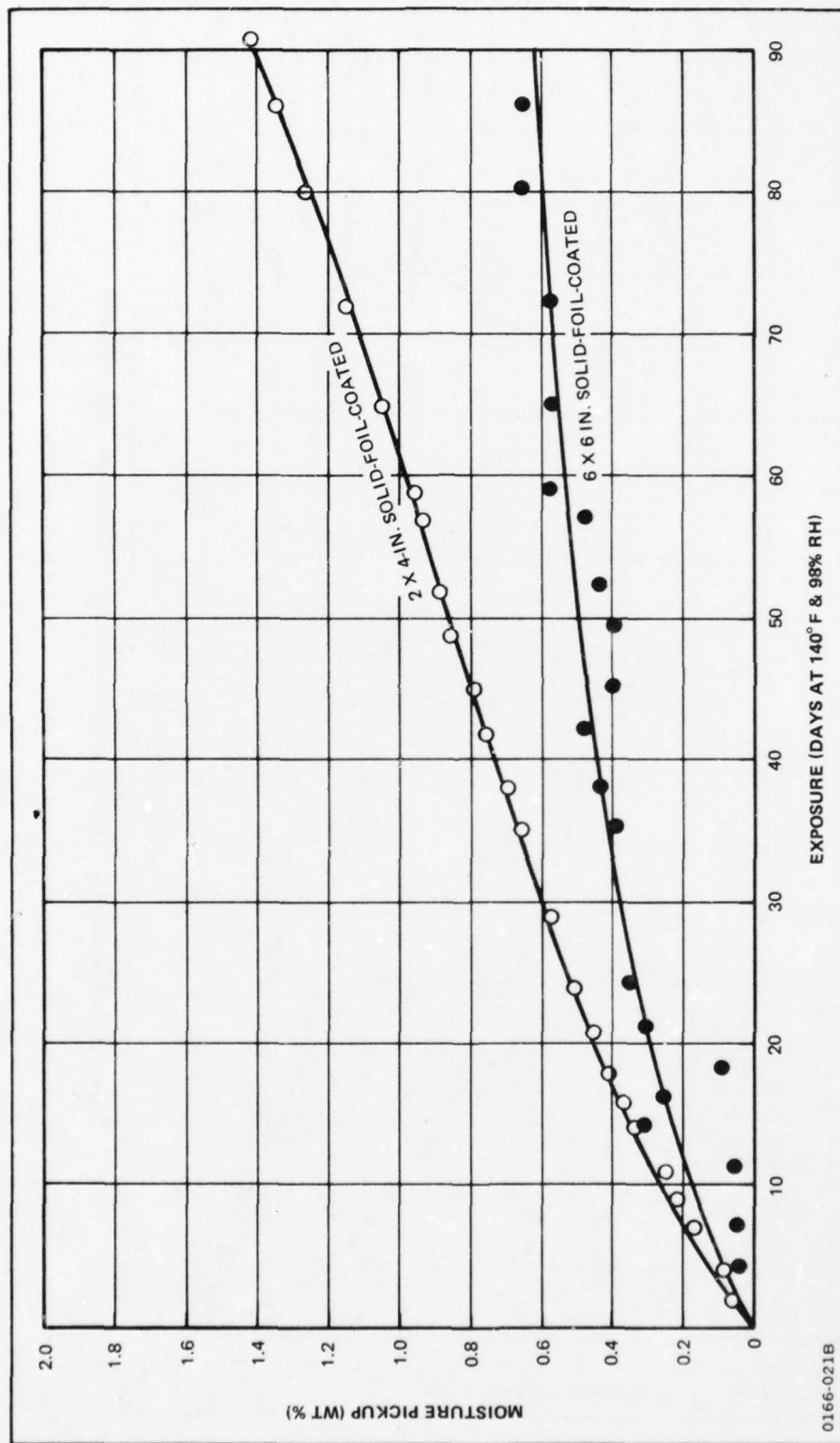

Figure 4-19 Effect of Size on Moisture Pickup of Solid-Foil-Coated Graphite/Epoxy

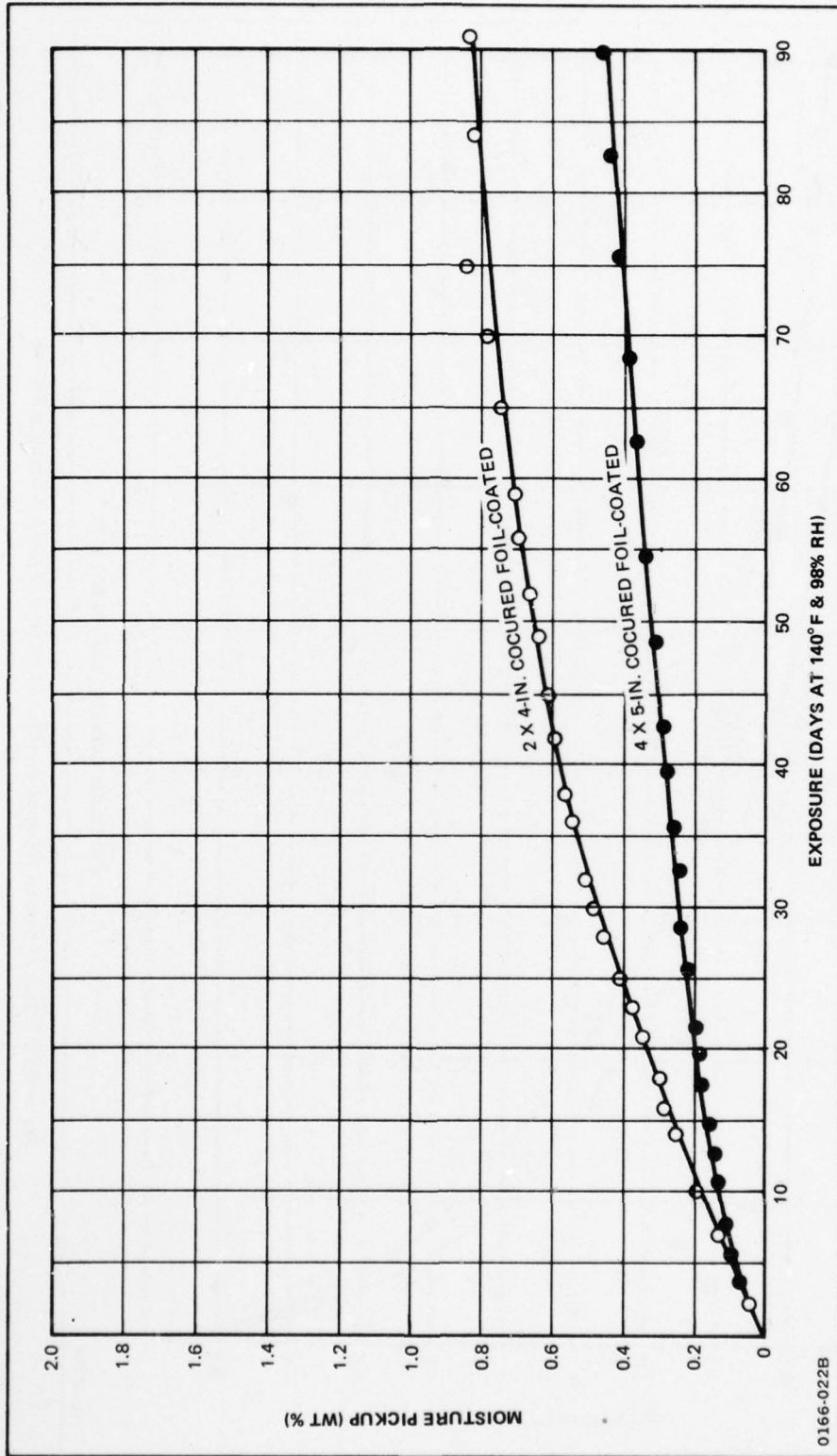

Figure 4-20 Effect of Size on Moisture Pickup of Cured Foil-Coated Graphite/Epoxy

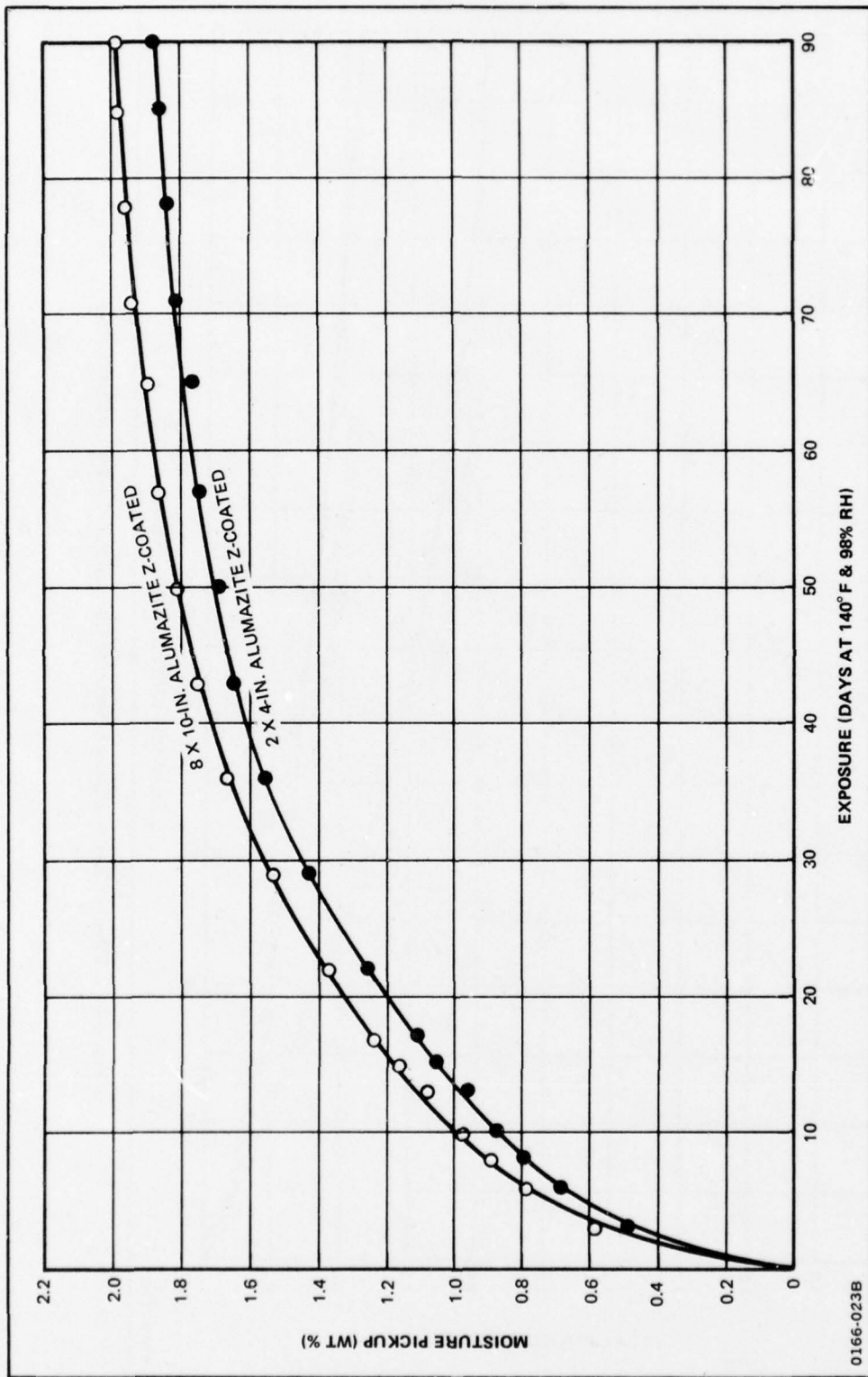

Figure 4-21 Effect of Size on Moisture Pickup of Alumazite Z-Coated Graphite/Epoxy

0166-023B

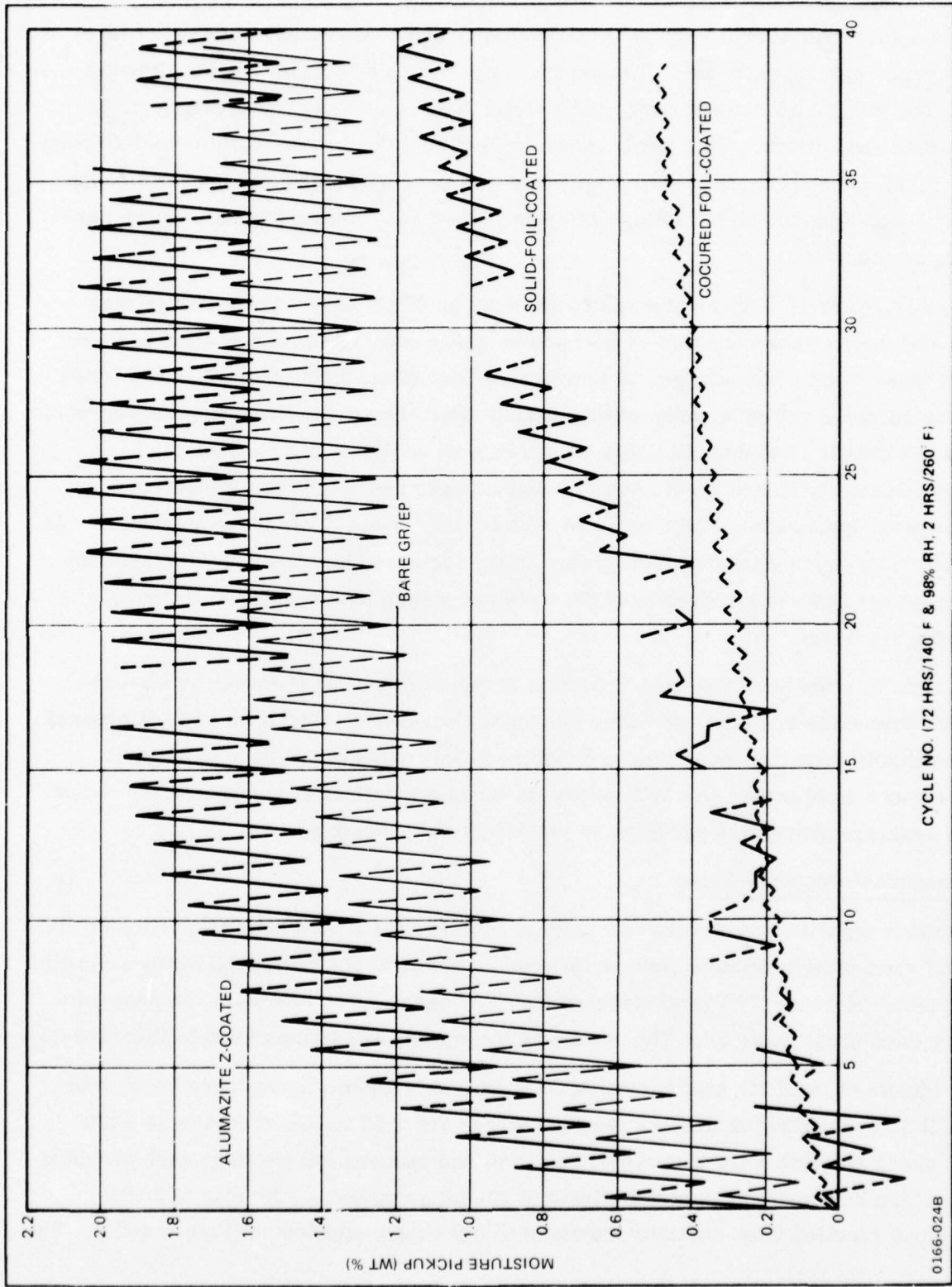

Figure 4-22 Relative Coating Effectiveness in Moisture Penetration Under Thermal Spiking Exposure (6 X 6 In. Panels)

4.6.2 Thermal Spiking Exposure

The moisture resistance of the selected coating systems was also evaluated under humidity-thermal spiking exposure. The exposure cycle (140°F and 98% RH for 72 hours followed by 260°F for 2 hours) was designed to simulate accelerated ground storage and supersonic flight conditions. Test panels were exposed to 40 cycles of humidity and thermal spiking. Weight determinations were made before and after each spike; the percent change in weight was then determined for each of the exposed panels. A bare graphite/epoxy panel was used as the control.

The moisture level of thermally spiked (90 days or 26 cycles) bare specimens was 27% higher before the spike than that of the bare humidity exposed specimen after a 90-day exposure (Figure 4-23). This suggested microcrack formation during thermal cycle which served as preferential diffusion paths and additional moisture sites. However, micrographic analysis in the 100x to 400x magnification range showed no difference between the bare humidity and thermally spiked specimens or between these specimens and the exposed and unexposed coated specimens. The number of microcracks observed in these specimens was insignificant. Comparison of the weight pickup of the three coating types showed that both of the foil coatings provide a reduction of the moisture pickup with respect to the bare specimen (Figure 4-22).

The solid foil coating provided a reduction in moisture pickup after 40 cycles (140 days) of 24% before the spike and 23% after the spike, compared to the bare control exposed to the same conditions. The reduction in moisture pickup provided by the cocured foil coating at the end of 40 cycles was 71% before the spike and 66% after the spike. No reduction in the moisture pickup was provided by the Alumazite Z coating.

4.6.3 Mechanical Property Tests

Following exposure to humidity and thermal spiking, the mechanical properties of the exposed and unexposed specimens were determined. Flexural and horizontal shear strengths were determined at room (73°F) and elevated (260°F) temperatures to assess the protection provided by each of the coatings. The results of these tests are summarized in Figure 4-24.

The effects of humidity and thermal spiking on bare graphite/epoxy were found to be severe; a 45 to 50% reduction in 260°F flexural stress and a 50 to 55% reduction in 260°F horizontal shear strength were observed. Solid foil and cocured foil coatings each provided protection of the composite against the effects of humidity exposure. No loss of 260°F flexural stress resulted from humidity exposure of foil coated specimens (Figure 4-25). The

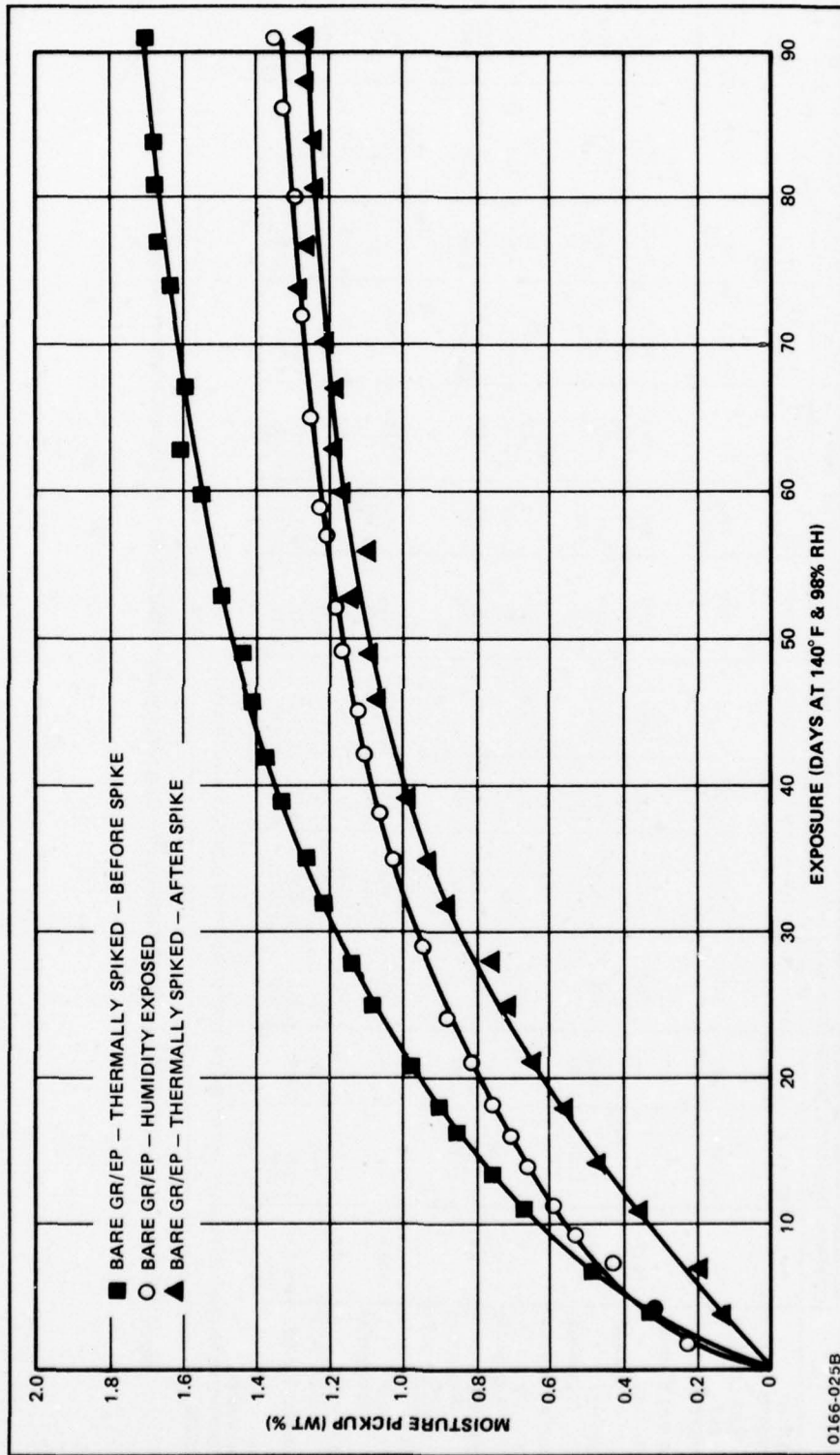

Figure 4-23 Relative Effects of Moisture Penetration of Bare Graphite/Epoxy Under Humidity and Thermal Spiking Exposure

	BARE*			SOLID FOIL*			COURED FOIL*			ALUMAZITE Z*						
	CONTROL	HUMIDITY	SPIKED	CONTROL	HUMIDITY	SPIKED	CONTROL	HUMIDITY	SPIKED	CONTROL	HUMIDITY	SPIKED	HUMIDITY	SPIKED	HUMIDITY	SPIKED
		91 DAYS	40 CYCLES	91 DAYS	91 DAYS	40 CYCLES	90 DAYS	90 DAYS	39 CYCLES	90 DAYS	90 DAYS	40 CYCLES	90 DAYS	90 DAYS	40 CYCLES	40 CYCLES
LENGTH OF EXPOSURE AT TEST (BEFORE SPIKE)	-	1.36	1.41 (1.73)	0.17	0.67	1.09 (1.31)	0.01	0.46	0.49 (0.51)	0.11	2.00	1.24 (1.69)	2.00	1.24 (1.69)	2.00	1.24 (1.69)
FLEXURAL STRESS																
73°F KSI (% CHANGE)	160.9	-	-	158.6	160.9 (+2)	154.4 (-3)	185.8	184.7 (-1)	152.7 (-15)	175.8	196.2 (12)	181.3 (+3)	174.6 (-7)	181.3 (+3)	177.2 (+1)	177.2 (+1)
260°F KSI (% CHANGE)	153.4	85.6 (-44)	78.8 (-49)	148.6	150.5 (+1)	64.1 (-57)	175.3	173.1 (-1)	130.1 (-26)	160.1	49.4 (-69)	91.6 (-43)	63.6 (-60)	91.6 (-43)	67.6 (-58)	67.6 (-58)
FLEXURAL MODULUS																
73°F MSI (% CHANGE)	7.7	-	-	7.7	7.7 (0)	7.6 (-3)	8.8	8.4 (-4)	7.1 (-19)	8.7	9.1 (+5)	9.0 (+3)	7.9 (-9)	9.0 (+3)	8.2 (-5)	8.2 (-5)
260°F MSI (% CHANGE)	7.6	6.6 (-13)	6.3 (-17)	6.9	7.2 (+5)	5.6 (-19)	7.1	8.0 (+13)	7.2 (+1)	9.0	5.3 (-41)	6.8 (-25)	5.2 (-42)	6.8 (-25)	5.8 (-36)	5.8 (-36)
HORIZONTAL SHEAR STRENGTH																
73°F KSI (% CHANGE)	10.6	-	-	11.4	11.5 (+1)	11.2 (-2)	10.6	11.2 (+6)	11.8 (+11)	11.0	10.8 (-2)	10.7 (-3)	10.5 (-5)	10.7 (-3)	9.7 (-11)	9.7 (-11)
260°F KSI (% CHANGE)	8.2	4.0 (-51)	3.6 (-56)	8.4	7.0 (-17)	5.6 (-33)	9.2	8.6 (-7)	7.6 (-17)	8.2	3.9 (-52)	4.2 (-49)	4.0 (-51)	4.2 (-49)	4.4 (-46)	4.4 (-46)
THICKNESS RANGE, IN.	0.093-0.098	0.096-0.098	0.097	0.098-0.105	0.096-0.105	0.098-0.103	0.112-0.115	0.112-0.115	0.113-0.119	0.091-0.098	0.092-0.098	0.088-0.095	0.103-0.106	0.088-0.095	0.104-0.106	0.104-0.106

* UNPAINTED.
 ** TESTS REPEATED TO VERIFY SHIFT IN TRENDS OF STRENGTH AFTER HUMIDITY AND SPIKING.
 0166-0268

Figure 4-24 Results of Foil-and Metal-Filled Resin-Coated Graphite/Epoxy (AS/3501-6) — Moisture Resistance Coating Selection Tests

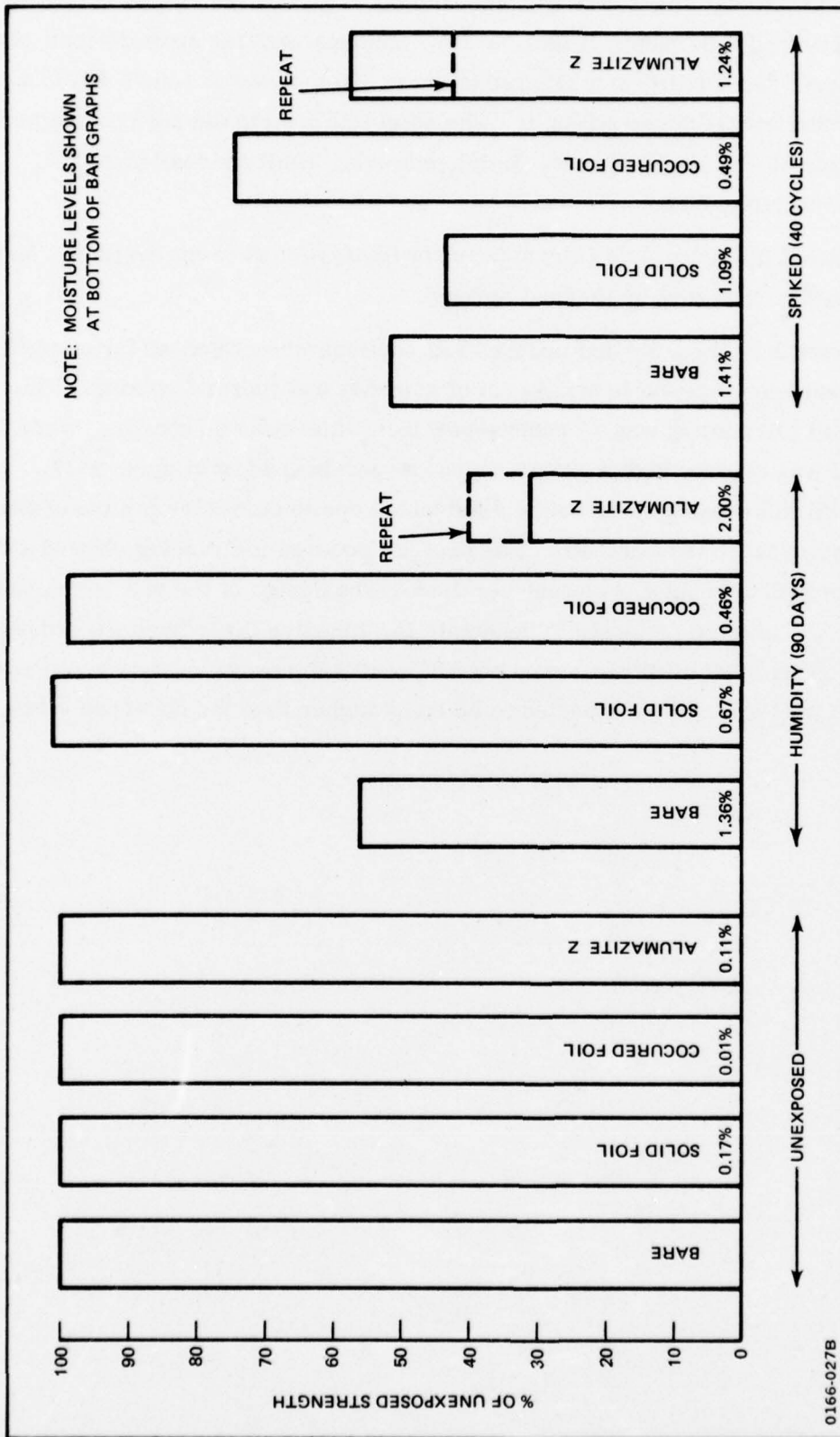

Figure 4-25 Coating Selection — Flexural Stress (260° F) as Percent of Unexposed Strength

reduction of 260°F horizontal shear strength was limited to 17% by the solid foil coating and to only 7% by the cocured foil coating (Figure 4-26). Thermal spiking strength loss was limited by the cocured foil coating to a 26% reduction in 260°F flexural stress and to a 17% reduction in 260°F horizontal shear strength. The solid foil coating did not provide protection from loss of 260°F flexural stress. It did, however, limit the loss of 260°F horizontal shear strength to 33%.

The Alumazite Z did not provide any significant improvement in the strength retention of laminates exposed to humidity or thermal spiking.

The peel strength of the solid and cocured foil coatings was evaluated for unexposed specimens and specimens exposed to conditions of humidity and thermal spiking. The peel strength of the solid foil coating was 15 pounds-per-inch width before exposure, while that of the cocured foil was slightly higher, at 17.5 pounds-per-inch width (Figure 4-27). Peel strength of the solid foil coating could not be determined due to corrosive failure of the foil at the point of attachment to the laminate. The exposed cocured foil coating showed a reduction of peel strength to about 4.3 pounds-per-inch. The design of the peel strength test specimens, however, allowed moisture to penetrate the adhesive layer from the sides (Figure 4-28). Because this condition would not be present in normal coating applications, the actual exposed peel strength is expected to be much higher than the observed value.

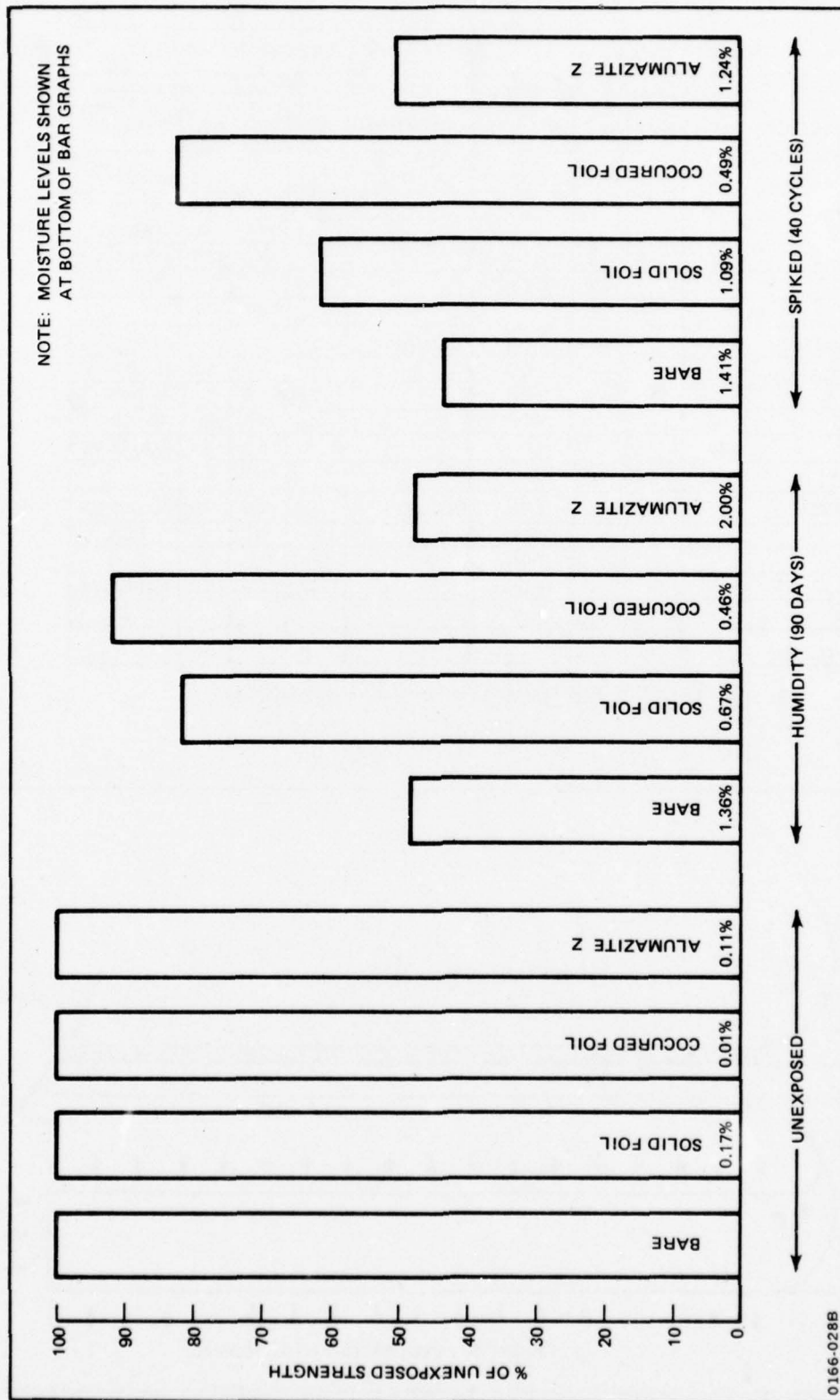
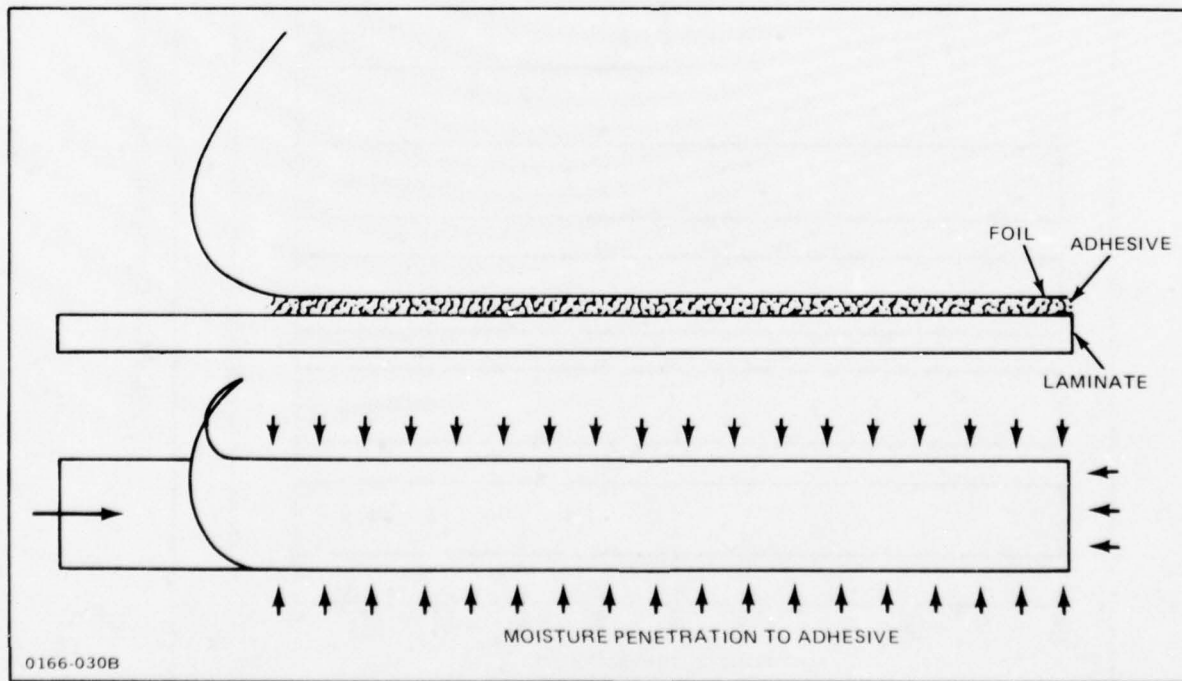

Figure 4-26 Coating Selection - Horizontal Shear Strength (260° F) as Percent of Unexposed Strength

SOLID FOIL COATING					COCURED PERFORATED FOIL				
CONDITION	PEEL RESISTANCE, LB/IN.				CONDITION	PEEL RESISTANCE, LB/IN.			
	MIN	MAX	AVG	FAILURE		MIN	MAX	AVG	FAILURE
CONTROL	10.9	19.3	15.1	COHESIVE	CONTROL	15.7	19.0	17.5	COHESIVE
	-	-	-	FOIL		13.4	18.1	16.4	COHESIVE
	-	-	-	FOIL		15.5	18.9	18.0	COHESIVE
	11.0	19.2	14.9	COHESIVE		16.3	19.2	17.9	COHESIVE
	8.0	21.7	15.7	COHESIVE		15.9	19.1	17.7	COHESIVE
		AVG	15.2				AVG	17.5	
HUMIDITY	-	-	-	FOIL	HUMIDITY	2.8	6.2	4.9	ADHESIVE
	-	-	-	FOIL		3.8	5.9	5.0	ADHESIVE
	-	-	-	FOIL		2.6	4.8	3.9	ADHESIVE
	-	-	-	FOIL		3.0	4.5	3.7	ADHESIVE
	-	-	-	FOIL		2.7	5.2	4.1	ADHESIVE
		AVG	-				AVG	4.3	
SPIKED	-	-	-	FOIL	SPIKED	1.4	5.0	3.5	ADHESIVE
	-	-	-	FOIL		-	-	-	FOIL
	-	-	-	FOIL		-	-	-	FOIL
	-	-	-	FOIL		2.6	6.6	4.3	ADHESIVE
	-	-	-	FOIL		-	-	-	FOIL
		AVG	-				AVG	-	
0166-029B									

Figure 4-27 Peel Strength, Foil-Coated Graphite/Epoxy



0166-030B

Figure 4-28 Design of Peel Strength Test Specimens

Section 5

SERVICEABILITY EVALUATION

5.1 APPROACH

This phase of the program was directed towards determining the resistance of selected coatings to aircraft service environments. One foil coating and one spray-and-bake type coating, selected in Phase II, were exposed to humidity and thermal spiking and tested to determine strength retention, bending fatigue, paint stripper resistance, EMI shielding effectiveness, and machinability.

5.2 STUDY AREAS

The following technical efforts were involved in the determination of coating serviceability in the aircraft environment:

- Coating selection
- Panel preparation and exposure
- Moisture pickup and strength retention evaluation
- Paint stripper evaluation
- Machining evaluation
- EMI testing
- Corrosion evaluation
- Lightning strike protection.

5.3 COATING SELECTION

One foil coating and one spray-and-bake type coating were selected for serviceability evaluation based on the Phase II evaluations. The solid-foil coating was selected for serviceability evaluation, since development of prebleeding procedures for the cocured foil was still in progress at the time of selection. Comparison of the moisture resistance of the two foil coatings showed that the cocured foil allowed less moisture pickup than the solid foil (Figure 4-17). However, the strength retention provided after humidity exposure was equivalent for both foil coatings (Figures 4-25 and 4-26). Selection of the spray-and-bake coating was based on the impact resistance and moisture pickup of the three

candidate coatings. Alumazite Z had slightly better impact resistance (Figure 4-12) and slightly less moisture pickup (Figure 4-13) than the silver-filled Alumazite Z or aluminum-filled Kerimid 500.

5.4 PANEL PREPARATION AND EXPOSURE

Graphite/epoxy serviceability panels were prepared, cut into subpanels, coated with foil and spray-and-bake coatings, and painted prior to environmental exposure and testing. The 18-ply AS/3501-6 graphite/epoxy major panels (Figure 5-1) were laid-up and cured according to the procedure established in Phase I. Ultrasonic scanning showed that all panels were satisfactory. The major test panels were sectioned into the subpanel sizes shown in Figure 5-1. The subpanels were coated with solid foil and Alumazite Z coatings according to procedures established in Phase II. The coated test panels were painted with standard Navy paint finish - epoxy polyimide primer (MIL-P-23377) with polyurethane topcoat (MIL-C-81773). The painted test panels were exposed to humidity (140°F and 98% RH) and thermal spiking (3 days at 140°F and 98% RH followed by 2 hours at 260°F) for 90 days and 25 cycles, respectively.

5.5 MOISTURE AND PAINT STRIPPER EFFECTS ON STRENGTH RETENTION

The serviceability of solid-foil and Alumazite Z-coated graphite/epoxy under the conditions of humidity and thermal spiking was evaluated in terms of resistance to moisture pickup, strength retention, paint stripper resistance, and resistance to bending fatigue. It was demonstrated in Phase II that exposure to humidity and thermal spiking causes an increase in the moisture content and a degradation of the mechanical properties of the graphite/epoxy laminate. It was also demonstrated that a solid-foil protective coating reduced the moisture pickup and improved the strength retention of the laminate after humidity and thermal spiking exposure. Panels exposed and tested under Phase III serviceability evaluation verified these results.

The moisture resistance of the solid-foil coating was improved under humidity and thermal spiking exposure by protecting the foil with paint. The painted, solid-foil-coated laminates picked up 73% less moisture after 90 days of humidity exposure (140°F and 98% RH) than the unpainted, solid-foil-coated laminate of the same size (Figure 5-2). The bare graphite/epoxy, however, showed a greater rate of moisture pickup in the early stages of humidity exposure when the laminate was painted, then decreased until the moisture pickup of the bare and painted laminates approached the same equilibrium value (Figure 5-3). These effects resulted from the combined tendency of the paint to pick up and transmit moisture (to the bare laminate), to protect the foil from corrosion, and to seal the foil

TECHNICAL EFFORT	MAJOR PANELS FOR ULTRASONIC SCANNING, IN.	NUMBER OF SAMPLES							
		SUBPANEL SIZES, IN.	FLEXURAL STRENGTH		INTER-LAMINAR SHEAR STRENGTH		PHOTO MICRO-ANALYSIS	EMI	LIGHTNING STRIKE
			73° F	260° F	73° F	260° F			
PHASE III – SERVICEABILITY	(2) 26.25 X 26.25 26.75 X 33								
<ul style="list-style-type: none"> PAINTED CONTROLS (HUMIDITY, SPIKING) 		(3) 6 X 6	9	9	9	9	6		
<u>ALUMINUM FOIL COATING</u> <ul style="list-style-type: none"> STRIPPER CONTROLS STRIPPER (CONTROL, HUMIDITY, SPIKING) MACHINING (CONTROL, HUMIDITY) 		6 X 6 (3) 6 X 6 (2) 6 X 6	3 9	3 9	3 9	3 9	4		
<u>SPRAY-AND-BAKE COATING</u> <ul style="list-style-type: none"> STRIPPER CONTROLS STRIPPER (CONTROL, HUMIDITY, SPIKING) MACHINING (CONTROL, HUMIDITY) 		6 X 6 (3) 6 X 6 (2) 6 X 6	3 9	3 9	3 9	3 9	4		
<u>EMI PROTECTION PANELS</u> <ul style="list-style-type: none"> PAINTED CONTROL ALUMINUM FOIL (CONTROL, SPIKING) SPRAY-AND-BAKE (CONTROL, SPIKING) 		12 X 12 (2) 12 X 12 (2) 12 X 12						1 2 2	
<u>LIGHTNING STRIKE PANELS</u> <ul style="list-style-type: none"> ALUMINUM FOIL (CONTROL, SPIKING) SPRAY-AND-BAKE (CONTROL, SPIKING) 		(2) 12 X 12 (2) 12 X 12							2 2

Figure 5-1 Serviceability Test Matrix

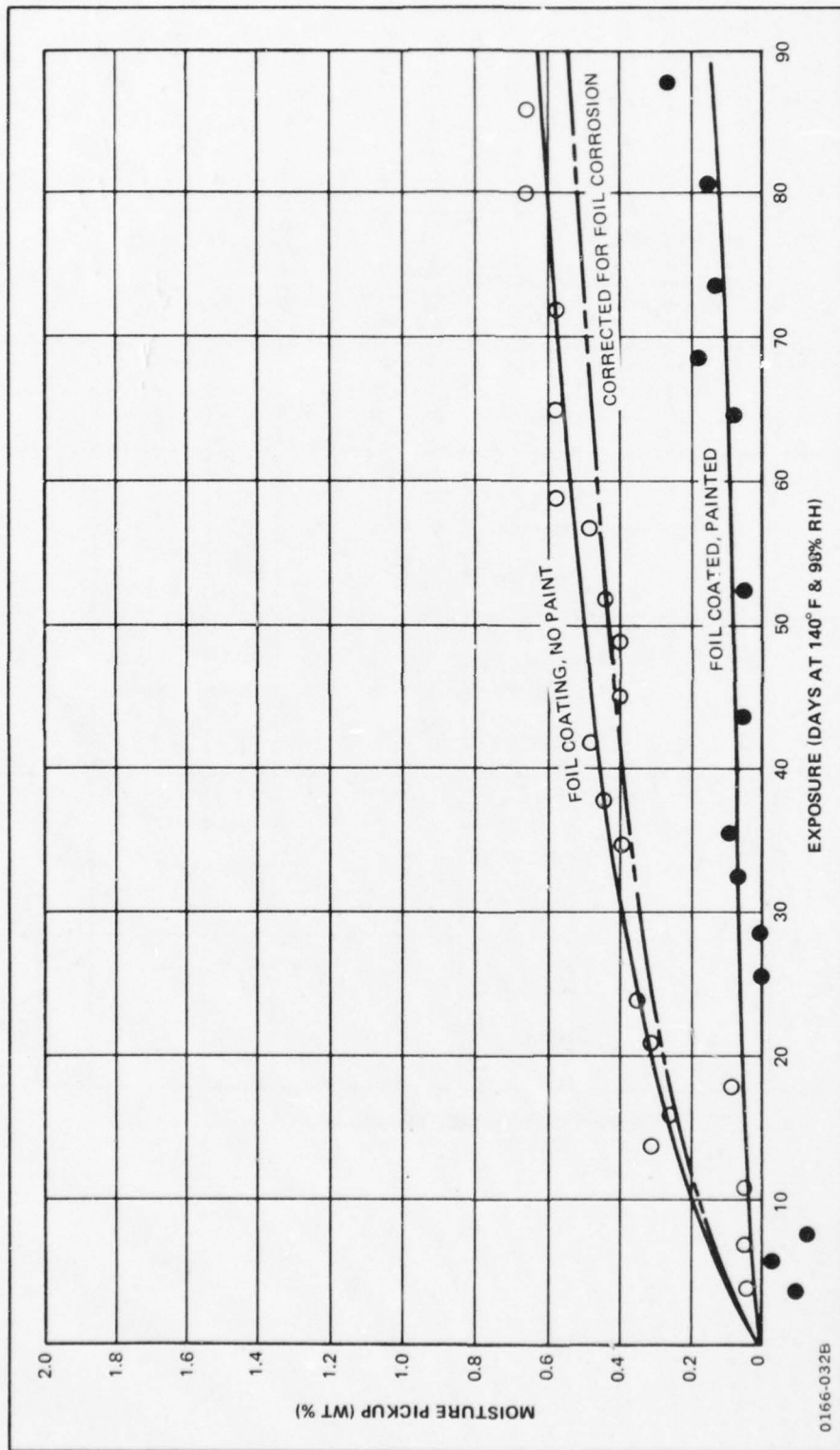

Figure 5-2 Effect of Paint Protection on Moisture Pickup of Solid-Foil-Coated Graphite/Epoxy

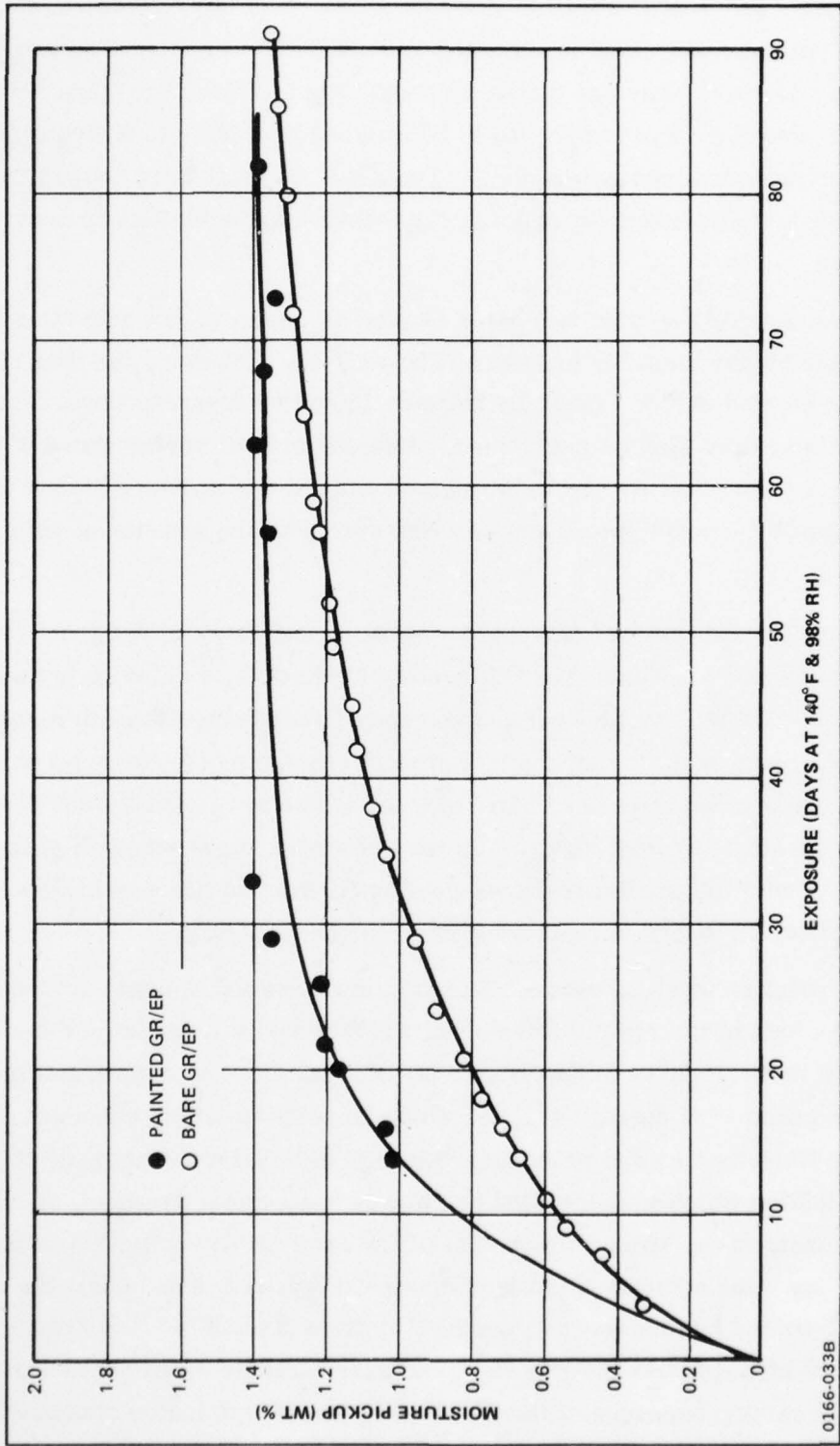

Figure 5-3 Effect of Paint Protection on Moisture Pickup of Bare Graphite/Epoxy

0166-033B

coating and edges. The effect of foil corrosion estimated in Phase II (paragraph 4.6.1) is shown for the unpainted foil coated laminate in Figure 5-2. A similar reduction in the moisture pickup of painted foil-coated laminates was observed in thermally spiked specimens (Figure 5-5). Negative moisture pickup values shown in Figures 5-2 and 5-5 were attributed to the fact that the large panels had to be weighed on a less-sensitive triple-beam balance rather than an analytical balance. Together, these results showed that paint provided a beneficial protective sealing effect to the foil coating in addition to providing corrosion protection.

The painted Alumazite Z-coated laminates showed an apparent 11% reduction in moisture pickup after 90 day humidity exposure (Figure 5-4). However, the data showed wide scatter for the painted panel, especially between 15 and 40 days exposure. Additional testing to rectify this scatter was not performed, since the overall performance of the coating was not sufficient to warrant it. A slight improvement in the moisture pickup of thermally spiked Alumazite Z-coated specimens was observed with the addition of paint protection (Figure 5-6).

Following humidity and thermal spiking exposure, paint was removed from exposed and unexposed specimens using Turco T-5469, a phenolic methylene chloride paint stripper conforming to MIL-R-81294. The flexural and horizontal shear strength of these specimens was determined and compared to the strength of control specimens (Figures 5-7 through 5-9). The effect of paint remover on unexposed bare specimens was to reduce the 260°F flexural strength by 18%. The effect of paint stripper on the horizontal shear strength of the laminate was not significant. Solid foil and Alumazite Z coatings prevented the loss in flexural strength resulting from the attack of paint stripper on graphite/epoxy.

The effect of paint stripper on exposed (humidity and thermal spiking) coated laminates was negligible. The loss of strength of foil-coated and Alumazite Z-coated laminates was less in the Phase III tests (Figures 5-7 through 5-9) with paint remover than that observed in Phase II tests (Figures 4-24 through 4-26) in which no paint remover was used. It is expected that this difference was due to the improvement in moisture resistance of the coatings under evaluation which was provided by painting the coating systems. While no significant improvement in the strength retention of the bare or Alumazite Z-coated laminates resulted from the addition of paint protection (Figures 5-8 and 5-9), the strength retention of the foil-coated laminates was improved by paint protection. No reduction in 260°F flexural strength and 260°F horizontal shear strength occurred as a result of humidity or thermal spiking exposure of the painted foil-coated laminates compared to the unexposed foil-coated control (Figures 5-7 to 5-9). It should be noted that the measured

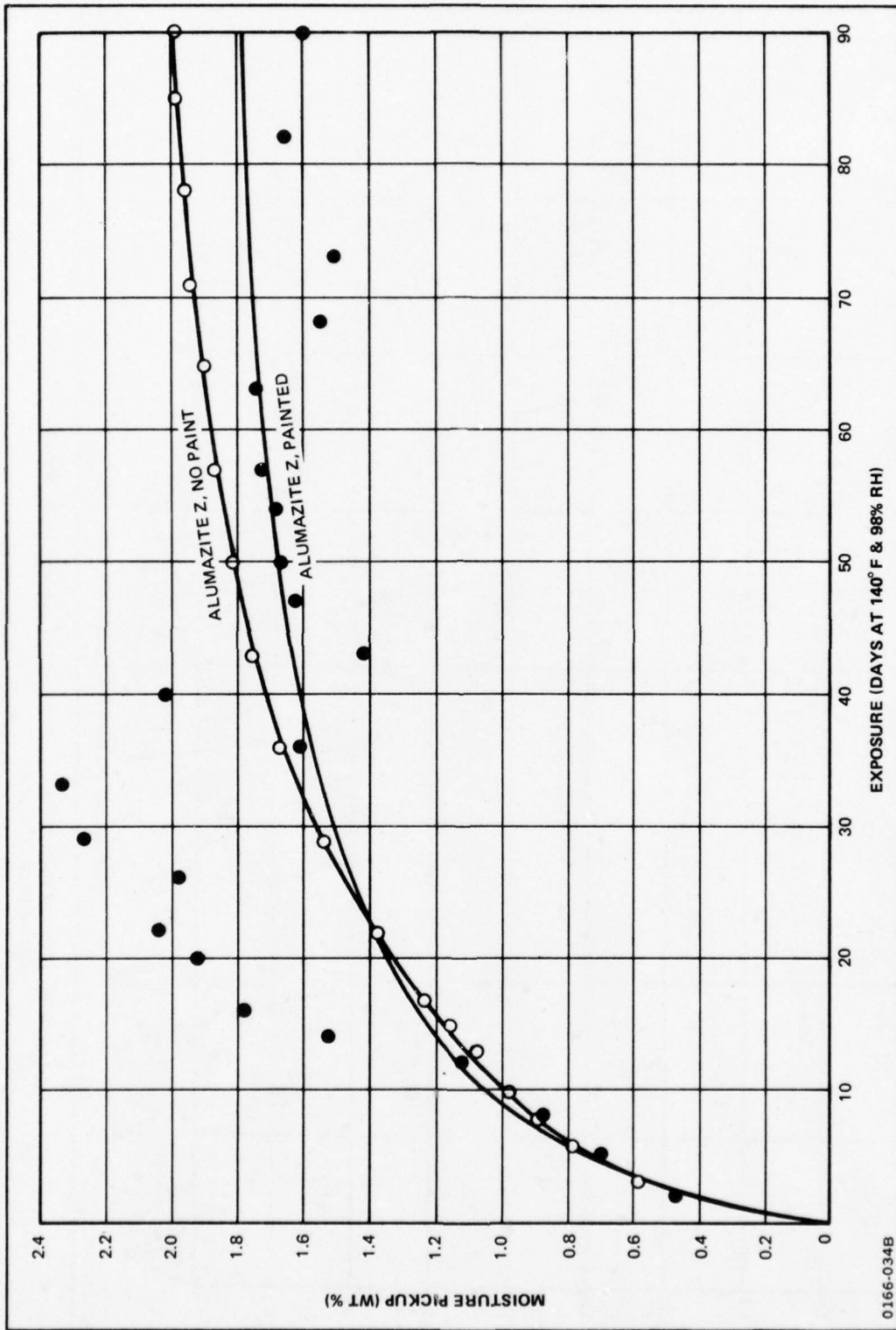

Figure 5-4 Effect of Paint Protection on Moisture Pickup of Alumazite Z-Coated Graphite/Epoxy

0166-034B

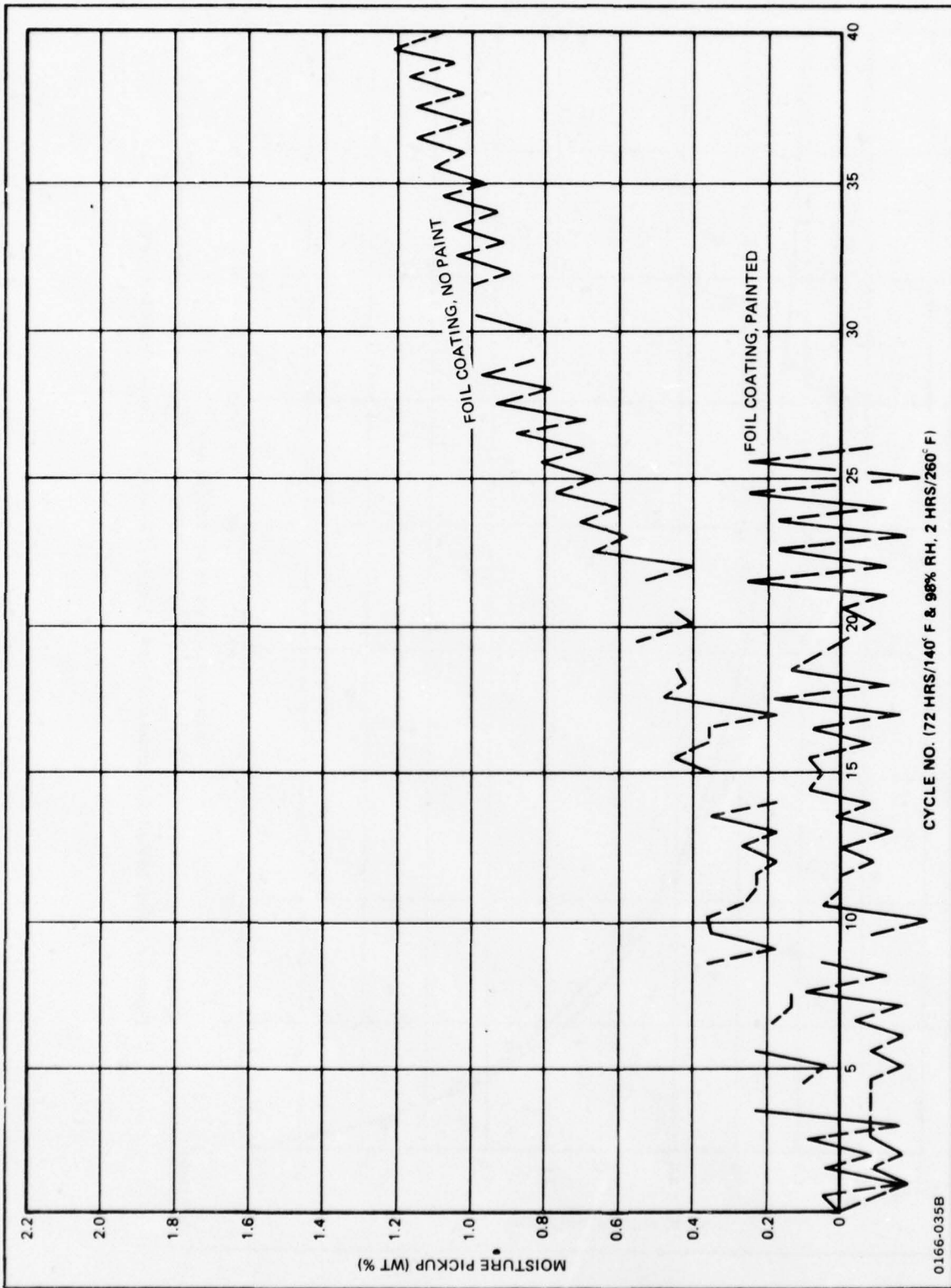
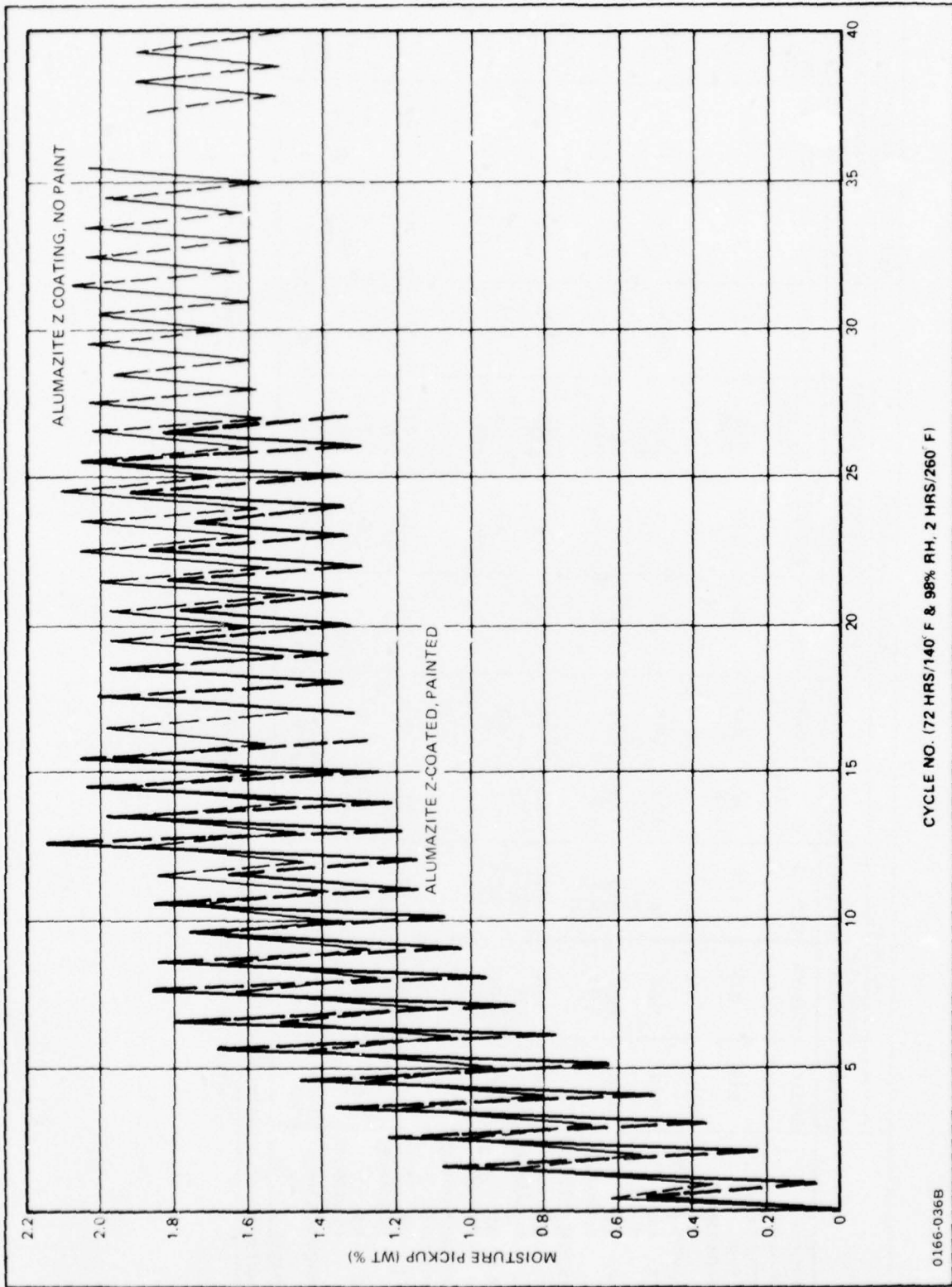

Figure 5-5 Effect of Paint Protection on Moisture Pickup of Thermally Spiked Solid Foil-Coated Graphite/Epoxy



CYCLE NO. (72 HRS/140° F & 98% RH, 2 HRS/260° F)

Figure 5-6 Effect of Paint Protection on Moisture Pickup of Thermally Spiked Almazite Z-Coated Graphite/Epoxy

0.166-036B

	PAINTED				PAINTED SOLID FOIL				PAINTED ALUMAZITE Z			
	CONTROL	REMOVER* CONTROL	HUMIDITY	SPIKED	CONTROL	REMOVER* CONTROL	REMOVER* HUMIDITY	REMOVER* SPIKED	CONTROL	REMOVER* CONTROL	REMOVER* HUMIDITY	REMOVER* SPIKED
	85 DAYS	85 DAYS	83 DAYS	26 CYCLES	91 DAYS	91 DAYS	88 DAYS	26 CYCLES	85 DAYS	85 DAYS	83 DAYS	26 CYCLES
LENGTH OF EXPOSURE	0.13	0.13	1.38	1.45 (1.85)	0.17	0.26	0.26	-0.09 (0.26)	0.15	0.15	1.63	1.33 (1.82)
MOISTURE LEVEL, % AT TEST (BEFORE SPIKE)												
FLEXURAL STRESS												
73° F KSI (% CHANGE)	163.8	162.0 (-1)	157.6 (-4)	167.2 (+2)	130.8	127.5 (-2)	151.0 (+15)	132.8 (+2)	160.9	161.3 (+3)	169.2 (+5)	168.9 (+5)
260° F KSI (% CHANGE)	158.0	130.4 (-18)	93.0 (-41)	87.3 (-45)	120.2	126.9 (+6)	136.1 (+13)	136.1 (+13)	154.3	147.6 (-4)	91.2 (-41)	92.5 (-40)
FLEXURAL MODULUS												
73° F MSI (% CHANGE)	7.9	7.5 (-5)	7.5 (-5)	8.0 (+1)	6.1	5.9 (-3)	6.8 (+11)	6.5 (+7)	7.9	8.2 (+4)	8.5 (+8)	8.6 (+9)
260° F MSI (% CHANGE)	7.4	7.0 (-5)	6.7 (-9)	6.8 (-8)	5.7	5.7 (0)	6.2 (+9)	6.2 (+9)	7.6	7.3 (-4)	6.9 (-9)	6.8 (-10)
HORIZONTAL SHEAR STRENGTH												
73° F KSI (% CHANGE)	11.7	11.1 (-5)	11.3 (-3)	9.0 (-23)	10.0	11.0 (+10)	10.4 (+4)	10.7 (+7)	11.9	11.6 (-3)	11.2 (-6)	9.0 (-24)
260° F KSI (% CHANGE)	8.9	8.7 (-2)	4.8 (-46)	4.3 (-52)	7.9	8.0 (+1)	8.1 (+3)	8.4 (+6)	8.6	9.0 (+5)	4.7 (-45)	4.6 (-47)
THICKNESS RANGE, IN.	0.099- 0.102	0.102- 0.105	0.099- 0.103	0.102- 0.103	0.114- 0.116	0.114- 0.116	0.110- 0.112	0.113- 0.115	0.100- 0.103	0.099- 0.102	0.098- 0.101	0.097- 0.102

* PAINT REMOVED USING MIL-R-81294 PAINT STRIPPER.

Figure 5-7 Results of Foil-and Metal-Filled Resin-Coated Graphite/Epoxy (AS/3501-6) - Serviceability Tests

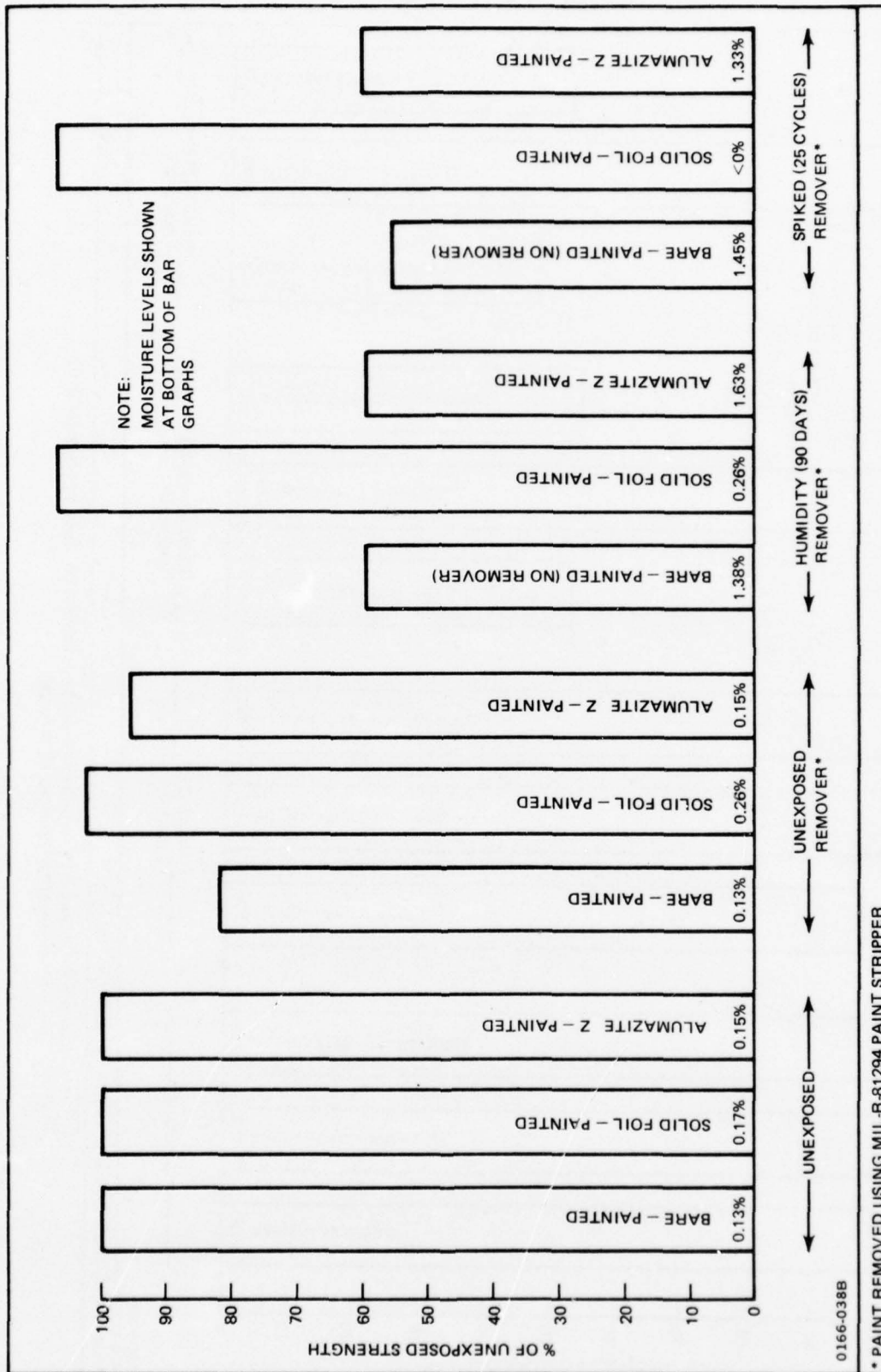

Figure 5-8 Coating Serviceability Evaluation - Flexural Stress (260° F) as Percent of Unexposed Strength

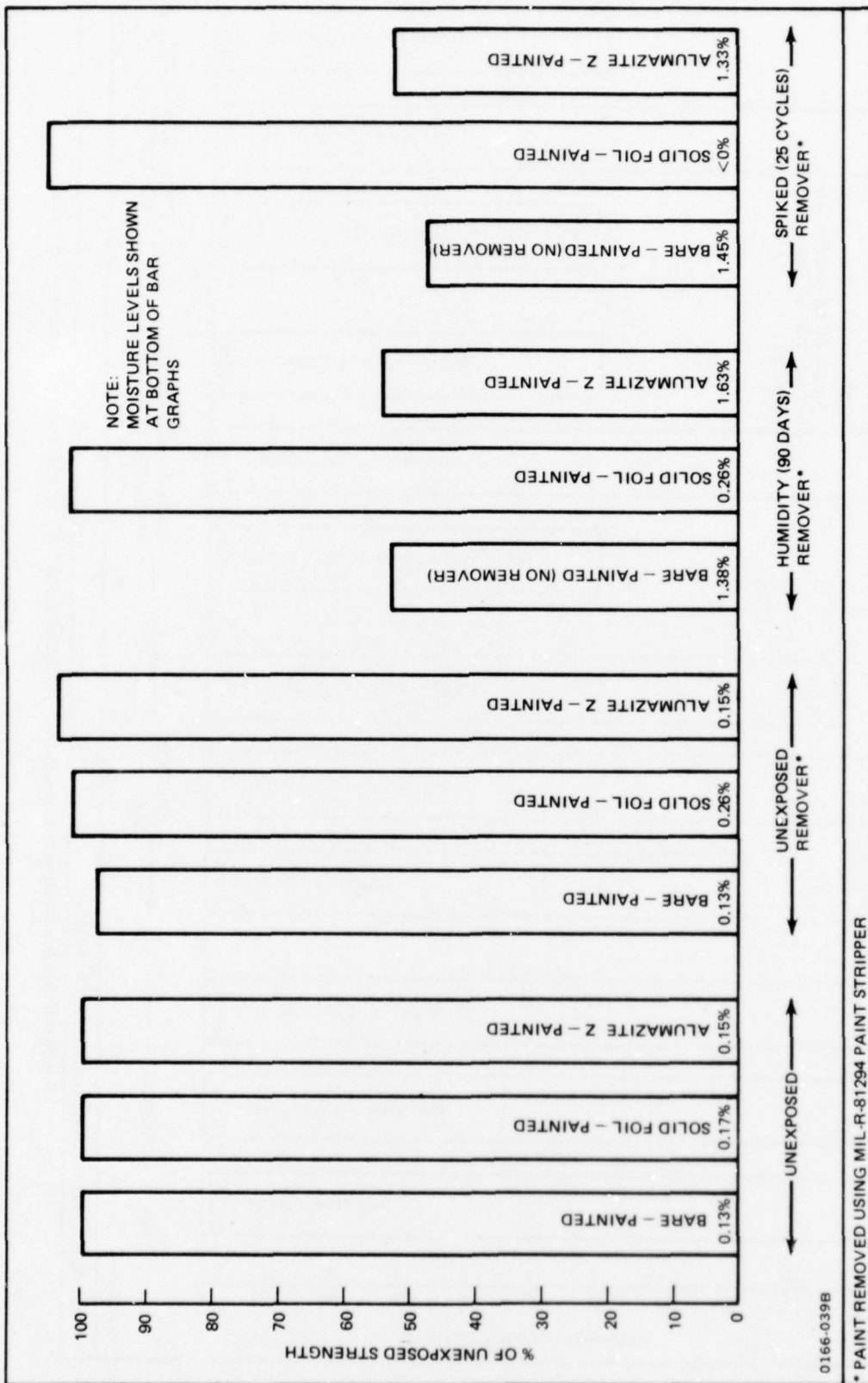

Figure 5-9 Coating Serviceability Evaluation - Horizontal Shear Strength (260°F) as Percent of Unexposed Strength

* PAINT REMOVED USING MIL-R-81294 PAINT STRIPPER

strength of these specimens was lower than that of the corresponding Phase II tests (Figure 4-24). However, this was at least in part due to the thickness of the cured laminate. Because the thickness of these panels was outside the range considered acceptable for normalization of the strength values, and because the effect that the foil coating had on strength was not determined, the values reported here have not been normalized for thickness. If the assumption is made that normalization can be used in this case, equivalent strength values will be obtained. However, the exposure and strength testing of the painted, solid-foil-coated laminates will be repeated in testing to be performed under a follow-on to this program to verify the conclusion that no strength reduction results from humidity or thermal spiking exposure of these laminates.

Fatigue resistance of the coated and uncoated laminates was determined under fully reversed bending at stresses ranging from 60 to 90 ksi. The fatigue resistance of the laminate was improved through the use of the painted solid-foil-coating (Figure 5-10). At 60 and 70 ksi, the humidity-exposed foil-coated specimens had better fatigue resistance than the unconditioned bare specimens, indicating that the foil tended to hold the surface plies of the laminate together in addition to providing moisture protection. The thermally spiked specimens had approximately the same fatigue resistance as the unconditioned bare specimens. The painted Alumazite Z-coated specimens had lower fatigue resistance after humidity and thermal spiking than the unconditioned control. Control and painted Alumazite Z-coated specimens experienced separation of the outer plus and minus 45-degree plies at the interface with the zero-degree plies, whereas the foil of foil-coated specimens separated from the laminate. The ply separations at relatively low stresses (60 ksi) were attributed to profound edge effects in the narrow specimens tested.

DESCRIPTION	RANGE OF CYCLES TO OUTER PLY OR FOIL SEPARATION X 10 ³			
	APPLIED STRESS, KSI			
	90	80	70	60
UNCOATED, UNCONDITIONED	6 - 8	24 - 48	25 - 43	75 - > 100
ALUMAZITE Z, HUMIDITY	-	-	13 - 42	58 - > 100
ALUMAZITE Z, SPIKED	-	-	15 - 21	31 - 59
SOLID FOIL, HUMIDITY	-	-	47 - > 100*	> 100
SOLID FOIL, SPIKED	-	2	11 - 83**	90 - > 100
* OF SIX SPECIMENS TESTED, ONE FAILED AT 1000 CYCLES (OMITTED FROM FIGURE)				
** OF SEVEN SPECIMENS TESTED, ONE FAILED AT 3000 CYCLES (OMITTED FROM FIGURE)				
0166-040B				

Figure 5-10 Coating Serviceability - Summary of Bending Fatigue Data (R = -1)

5.6 MACHINING EVALUATION

Machining characteristics of the solid-foil-coated and Alumazite Z-coated laminates were determined in exposed (humidity) and unexposed conditions. Drilling and radial sawing characteristics were evaluated with respect to hole and cut quality for various machining conditions.

Holes were drilled and countersunk, using a 6,000-rpm Dumore stationary drill press and a 21,000-rpm Gardner Denver portable drill. Initial tests on the solid-foil-coated laminate showed that a backup material was necessary to prevent breakout of the outer composite plies and the foil on the back of the laminate (Figure 5-11). Backup material was used for all additional tests. No coolant was used.

Higher quality holes were obtained with the 6,000-rpm Dumore drill than those drilled at 21,000 rpm for the foil coated laminate (Figure 5-11). Holes drilled at 6,000-rpm showed no burrs or hole breakout in the unexposed condition; holes drilled at 21,000-rpm required deburring to remove a foil burr at the hole exit. A decrease in hole quality resulted from humidity exposure. The hole quality of humidity exposed laminates was good at 6,000 rpm; however, burrs at the entrance of the countersinks could not be removed without causing slight tears in the foil. The quality of holes drilled at 21,000 rpm after humidity exposure was poor; the foil was badly ripped around the entrance to the holes and countersinks.

Drilling of holes in Alumazite Z-coated laminates caused the coating to chip around the hole entrance and exit. Chipping of the coating was minimized by drilling at 21,000 rpm. Lower drilling speed, humidity exposure, and drilling of countersinks each caused a reduction in quality.

Foil-coated and Alumazite Z-coated laminates were cut using a radial saw with a 80- to 100-grit diamond blade. The specimens were manually fed at two different rates without coolant. The resulting cut quality was examined. A normal feed rate of 21 to 24 inches per minute provided a good quality cut with a slight burring of the foil which must be removed (Figure 5-12). The cut quality of the Alumazite Z-coated laminates was very good. By feeding at twice the normal rate (40 to 55 inches per minute), the cut quality was unaffected.

The moisture content did not affect the quality of the cut for the foil-coated or Alumazite Z-coated laminates.

MATERIAL	DRILLING MACHINE (1)	SPEED (RPM)	FEED (IPR)	BACKUP	RESULTS						
					HOLES			C/SINKS			COMMENTS
					BURR	BREAKOUT	BURR	BURR	BREAKOUT	BURR	
SOLID FOIL COATING, UNEXPOSED	DUMORE	6000	0.001	YES	NONE	NONE	FOIL @ EXIT	FOIL @ EXIT	LAMINATE @ EXIT	ACCEPTABLE	
	DUMORE	6000	0.001	NO	—	—	—	—	—	NOT ACCEPTABLE	
	GARDNER-DENVER	21,000	0.001	YES	NONE	FOIL & LAMINATE @ EXIT (SLIGHT)	FOIL @ EXIT (SLIGHT)	FOIL @ EXIT (SLIGHT)	NONE	ACCEPTABLE WITH DEBURR STEP	
SOLID FOIL COATING, 90-DAY HUMIDITY EXPOSURE	DUMORE	6000	0.001	YES	FOIL @ EXIT (SLIGHT)	NONE	FOIL @ EXIT (SLIGHT)	FOIL @ ENTRY	NONE	HOLES ACCEPTABLE WITH DEBURR STEP; C/SINKS-NOT ACCEPTABLE (2)	
	GARDNER-DENVER	21,000	0.001	YES	FOIL @ ENTRY (SEVERE) & @ EXIT	NONE	FOIL @ ENTRY (SEVERE) & @ EXIT	FOIL @ ENTRY & EXIT	LAMINATE @ ENTRY	VERY POOR-NOT ACCEPTABLE	
	DUMORE	6000	0.001	YES	NONE	COATING @ EXIT	NONE	NONE	COATING @ EXIT	NOT ACCEPTABLE (2)	
ALUMAZITE Z COATING, UNEXPOSED	GARDNER-DENVER	21,000	0.001	YES	NONE	COATING @ ENTRY (SLIGHT) & @ EXIT (SLIGHT)	COATING @ ENTRY (SLIGHT)	NONE	COATING @ ENTRY & @ EXIT (SLIGHT)	HOLES-MARGINALLY ACCEPTABLE; C/SINKS-NOT ACCEPTABLE(2)	
	DUMORE	6000	0.001	YES	NONE	COATING @ ENTRY & EXIT	COATING @ ENTRY & EXIT	NONE	COATING @ EXIT	NOT ACCEPTABLE (2)	
ALUMAZITE Z COATING, 90-DAY HUMIDITY EXPOSURE	DUMORE	6000	0.001	YES	NONE	COATING @ ENTRY & EXIT	COATING @ ENTRY & EXIT	NONE	COATING @ EXIT	NOT ACCEPTABLE (2)	
	GARDNER-DENVER	21,000	0.001	YES	NONE	COATING @ ENTRY & EXIT	COATING @ ENTRY & EXIT	NONE	LAMINATE @ ENTRY COATING @ EXIT	NOT ACCEPTABLE(2)	

NOTES: (1) NO COOLANT USED; DUMORE - STATIONARY DRILL PRESS, AIR OVER OIL FEED; GARDNER-DENVER - PORTABLE DRILL MACHINE, AIR DRIVEN WITH POSITIVE MECHANICAL FEED.

(2) COATING SEPARATED AROUND HOLE; CANNOT BE REPAIRED

Figure 5-11 Drilling and Countersinking Evaluation - Painted Foil-Coated and Alumazite Z-Coated Graphite/Epoxy

MATERIAL	CUTTING SPEED, SFM	FEED RATE IPM	TIME PER CUT, MIN (6-IN., HANDFED)	COMMENT	COMPARISON
SOLID FOIL COATING, UNEXPOSED	7000	22.5	0.267	UNIFORM CUT;SLIGHT BURR AT BLADE EXIT UNIFORM CUT;SLIGHT BURR AT BLADE EXIT DEBURRING REQ'D	NO SIGNIFICANT DIFFERENCE IN CUT QUALITY BETWEEN FEED RATES
		48.6	0.123		
SOLID FOIL COATING, 90 DAY HUMIDITY EXPOSURE	7000	24.3	0.247	UNIFORM CUT;SLIGHT BURR AT BLADE EXIT UNIFORM CUT;SLIGHT BURR AT BLADE EXIT DEBURRING REQ'D	NO SIGNIFICANT DIFFERENCE IN CUT QUALITY BETWEEN FEED RATES
		45.0	0.133		
ALUMAZITE Z COATING, UNEXPOSED	7000	26.5	0.227	UNIFORM, SMOOTH CUT UNIFORM, SMOOTH CUT	NO SIGNIFICANT DIFFERENCE IN CUT QUALITY BETWEEN FEED RATES
		50.0	0.120		
ALUMAZITE Z COATING, 90 DAY HUMIDITY EXPOSURE	7000	26.9	0.223	UNIFORM, SMOOTH CUT UNIFORM, SMOOTH CUT; V. SL. PAINT CHIPPING AT BLADE EXIT	NO SIGNIFICANT DIFFERENCE IN CUT QUALITY BETWEEN FEED RATES
		52.9	0.113		

0166-042B

Figure 5-12 Radial Sawing Evaluation: Painted Foil-Coated and Almazite Z-Coated Graphite/Epoxy

5.7 SHIELDING EFFECTIVENESS

Shielding effectiveness is a measure of the ability of a material to control the passage of radiated electromagnetic energy. This is a necessary part of electrical and electronic equipment design to protect the equipment from the effects of interference from other electronic devices and to prevent it from propagating interference. Evaluation of the shielding effectiveness of solid-foil-coated and Alumazite Z-coated graphite/epoxy was made to assess the ability of these coatings in providing EMI shielding. Unconditioned and conditioned specimens were tested to determine the effect of thermal spiking on the shielding effectiveness. Shielding effectiveness measurements were made for low-impedance (H), high-impedance (E) and plane wave fields.

The shielding effectiveness of the unconditioned painted solid-aluminum-foil-coated graphite/epoxy was better than that of the bare composite for E-field, H-field and plane waves (Figure 5-13). Although thermal spiking of the solid-foil-coated laminates caused a slight overall reduction in shielding effectiveness, the effect varied with different fields and frequency ranges (Figure 5-14). In the E-field, thermal spiking showed a general increase in shielding effectiveness over the unexposed specimens, while the shielding remained constant or decreased slightly in the H-field. A decrease in the plane wave-field shielding effectiveness resulted from thermal spiking of the solid foil-coated laminates. The shielding effectiveness of the unconditioned painted Alumazite Z-coated graphite/epoxy was equivalent to or less effective than that for the painted uncoated graphite/epoxy (Figure 5-13). The effect of thermal spiking on the shielding effectiveness of Alumazite Z-coated graphite/epoxy varied for different fields and frequency ranges in a manner similar to the variation observed for the solid-foil-coated specimens discussed above (Figure 5-15).

The results of these tests demonstrated that the solid-foil coating can provide an improvement in the shielding effectiveness of graphite/epoxy, while the Alumazite Z does not affect the shielding effectiveness. Although only one sample of each condition was evaluated, this was considered a valid general conclusion. However, these measurements should be duplicated prior to application of the specific shielding effectiveness values.

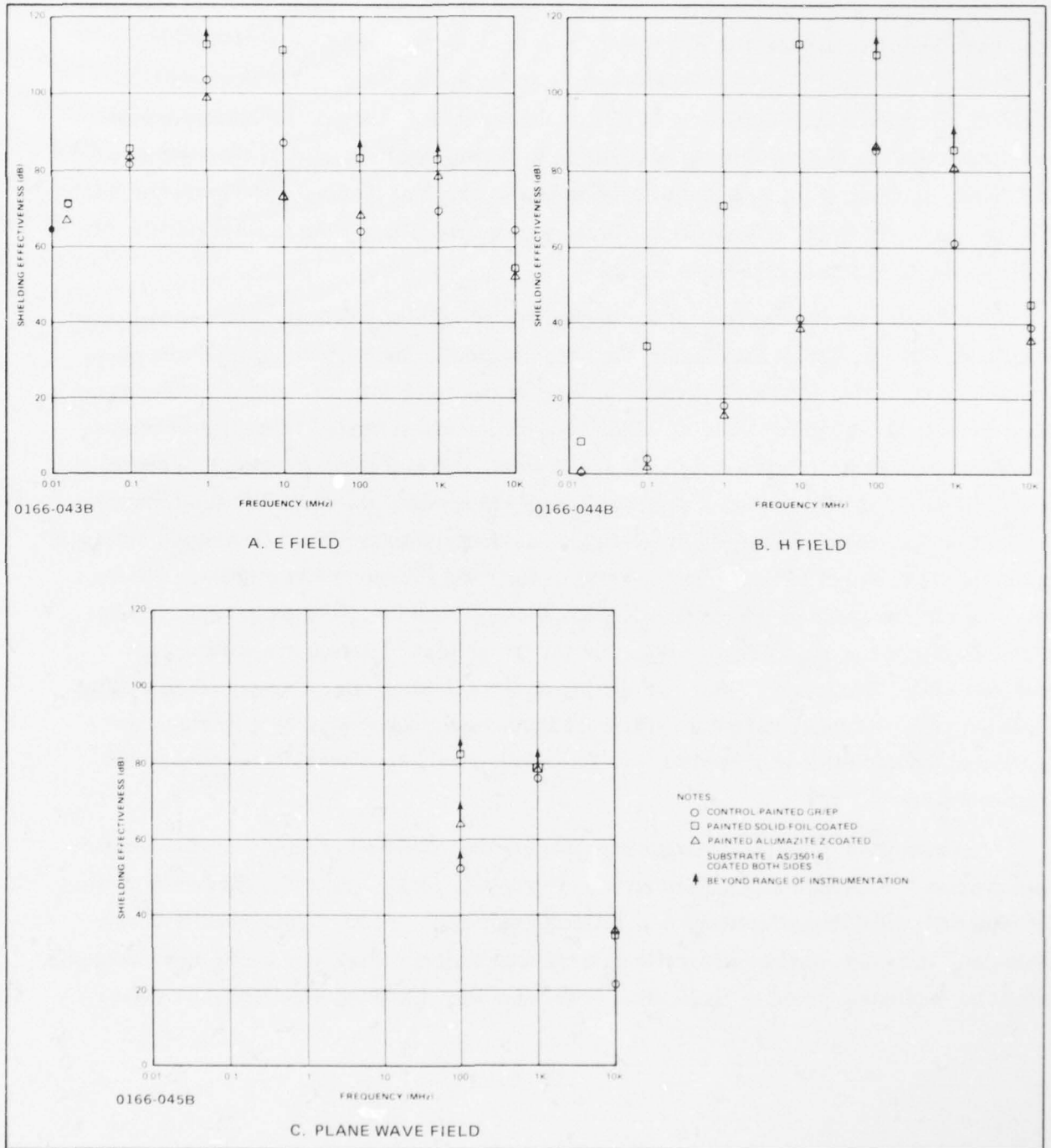

Figure 5-13 EMI Shielding Effectiveness of Solid-Foil-Coated and Alumazite Z-Coated Graphite/Epoxy

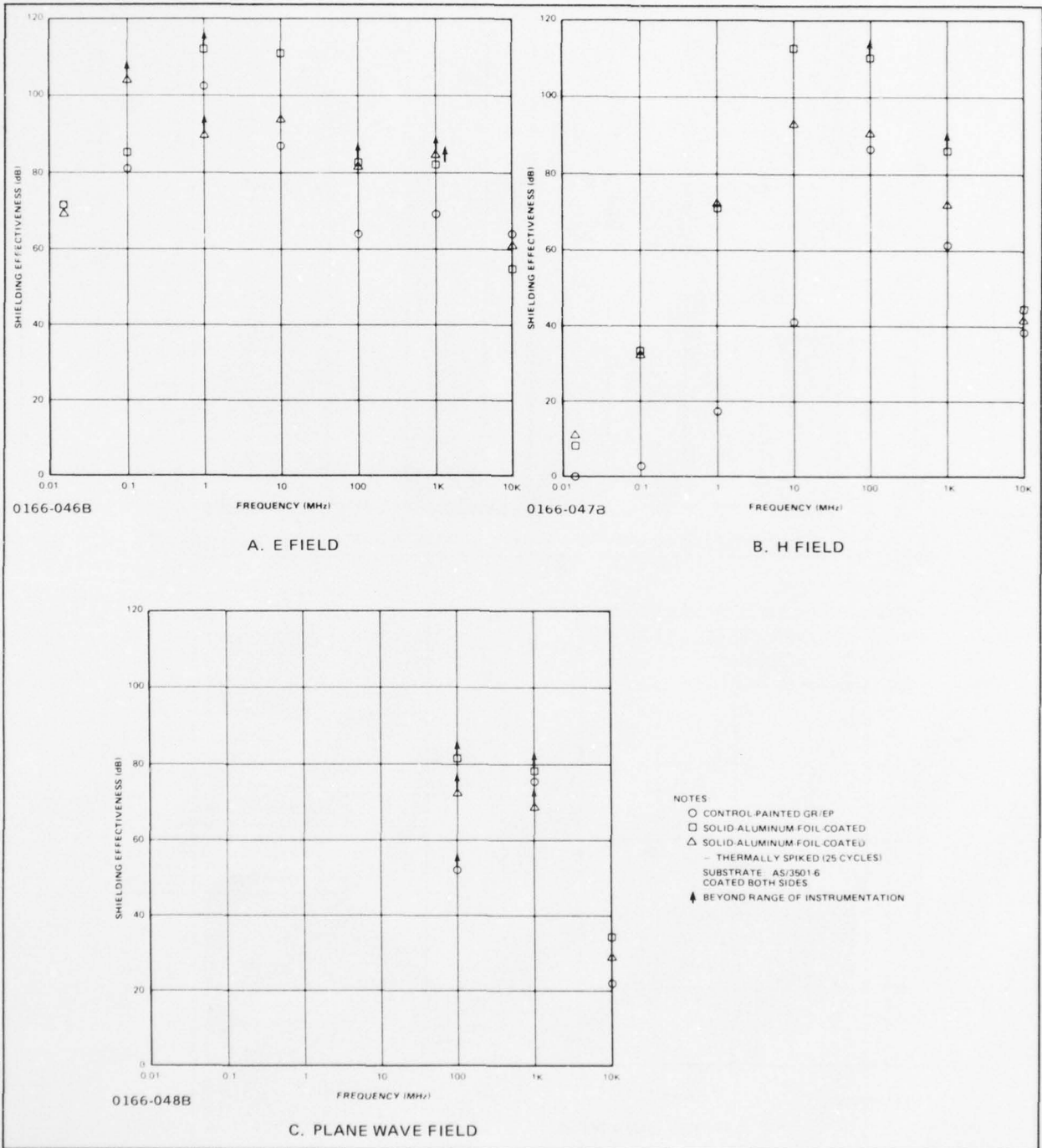

Figure 5-14 Effect of Thermal Spiking on EMI Shielding Effectiveness of Solid-Foil-Coated Graphite/Epoxy

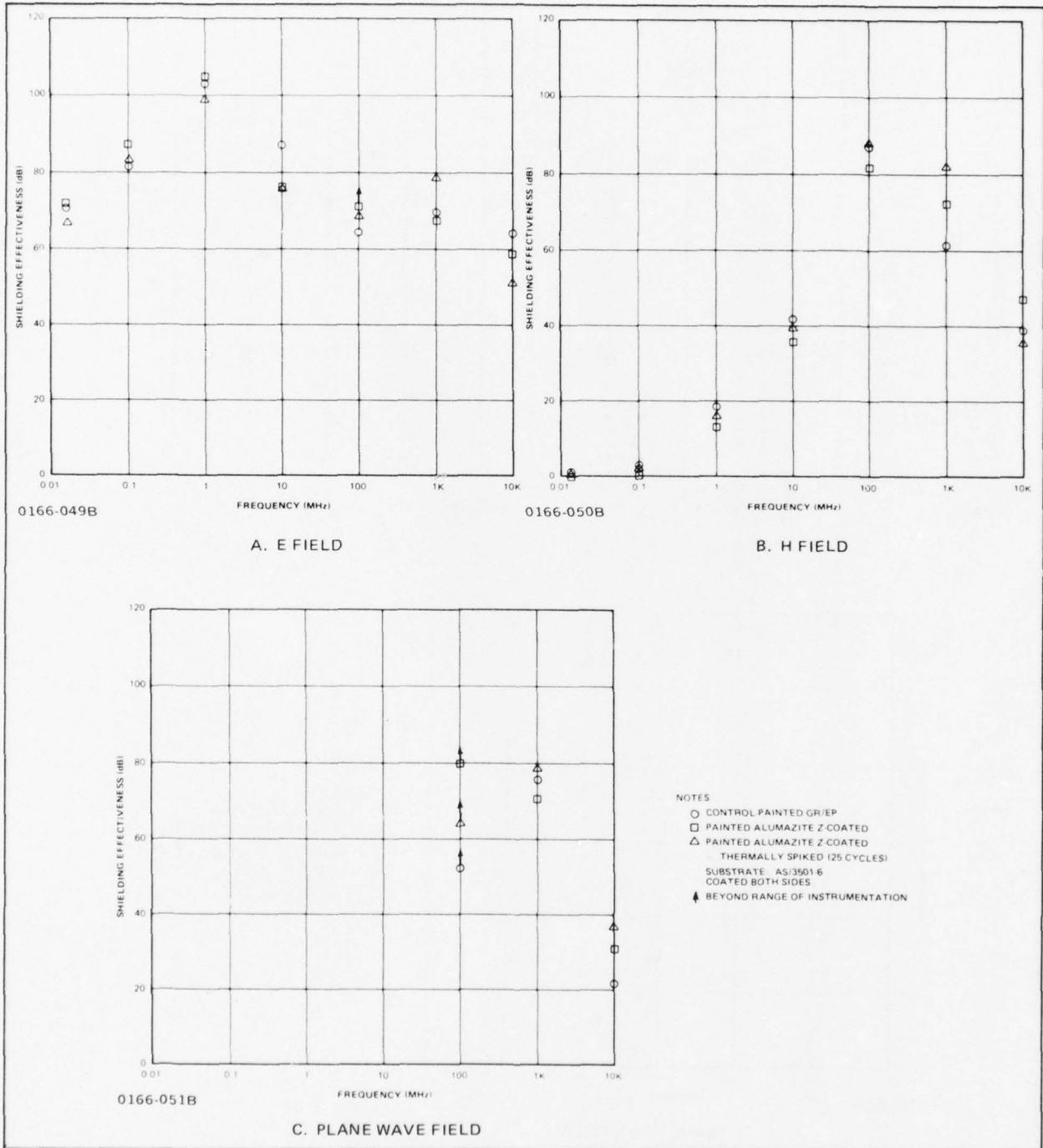

Figure 5-15 Effect of Thermal Spiking on EMI Shielding Effectiveness of Alumazite Z-Coated Graphite/Epoxy

5.8 CORROSION EVALUATION

The aluminum foil coating used to protect graphite/epoxy from the effects of moisture may be degraded by the actions of atmospheric and galvanic corrosion. It was shown that atmospheric corrosion resulting from exposure to high humidity (Phase II) can be prevented by painting the foil coating (Phase III). To assess the potential for galvanic corrosion, a scribe/salt-spray corrosion test was performed. A painted, foil-coated graphite/epoxy test specimen was scribed through the foil to the substrate and exposed for seven days to a 5% salt spray solution per ASTM Test Method No. B117-64. A control specimen was prepared by the same procedure, using an inert thermoplastic (polycarbonate) as the substrate. The control specimen was also scribed and exposed to 5% salt spray for seven days.

Both panels were examined for evidence of corrosion following the salt-spray exposure. Evidence of general corrosion of the aluminum was seen when viewed under a stereo-light microscope. The panels were then metallographically sectioned in three different areas across the scratch and compared. In each area the graphite/epoxy panel had some evidence of pitting corrosion attack of the 2024-T3 aluminum in the scratched area (Figure 5-16a). No pitting was observed on the polycarbonate control panel (Figure 5-16b). This pitting attack may have been due to a galvanic couple between the cathodic graphite and anodic aluminum. The potential problem caused by galvanic corrosion will be addressed as part of the future work planned as part of a follow-on to this program.

5.9 LIGHTNING STRIKE PROTECTION

The protection of graphite/epoxy against lightning strike by the solid-foil and Alumazite Z-coatings will be evaluated by NAVAIR. Lightning strike test panels coated with solid foil and Alumazite Z were painted with epoxy primer and polyurethane topcoat. One panel of each coating was exposed to 25 thermal spiking cycles (72 hours at 140°F and 98% RH followed by 2 hours at 260°F). A second panel of each coating was held in a desiccator for the same period. The conditioned panels have been submitted to NAVAIR for lightning strike evaluation.

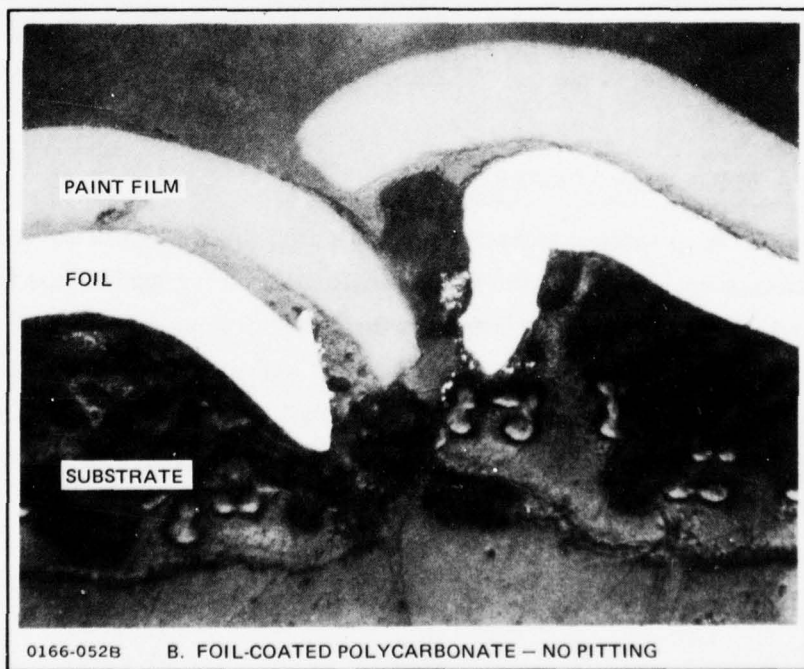
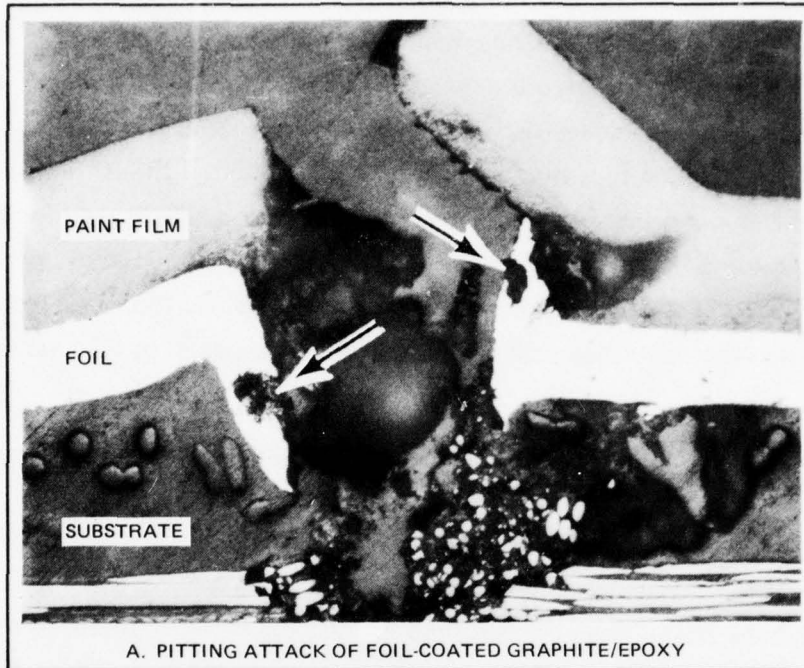

Figure 5-16 Photomicrograph Analysis of Foil-Coated Specimens After Seven-Day Scribe/Salt-Spray Exposure (200X)

APPENDIX A
TEST PROCEDURES

A.1 ENVIRONMENTAL CONDITIONING

Environmental conditioning of test panels was performed using a Hotpack humidity chamber. The chamber was held at the conditions of 140°F ($\pm 3^\circ\text{F}$) and 98% RH (+1, -3%) for the duration of the test. During temporary conditions of chamber repair, the specimens were held in sealed plastic bags or transferred to an alternate chamber, depending on the time required for repair. Minor variations in the humidity level in the chamber were reflected in the moisture pickup of all the specimens under exposure during certain periods. Because exposure of various specimens was started at different time intervals, however, direct comparison of these trends on the moisture pickup curves (Figures 4-17 to 4-23) could not be made. The overall humidity level also remained relatively constant, as shown by the same moisture pickup curves.

Thermal spiking of the test specimens was performed in an air-circulating oven held at a constant temperature of 260°F.

A.2 IMPACT RESISTANCE

The coatings under test were subjected to point impact loads to determine their resistance to impact. A variable impact tester (Figure A-1) was used to drop a fixed two-pound weight from various heights to the surface of the test specimens according to ASTM Test Method No. D-2794. The impact tester uses a 0.625-inch-diameter punch with a 0.64-inch-diameter female die. The coatings were visually inspected after each drop to determine the maximum impact force which the coating can withstand without damage for direct and indirect impact.

A.3 PEEL STRENGTH

The adhesion of bonded foil coatings was determined using the Bell method peel test according to the procedures of ASTM Test Method No. D-3167. Test specimens were prepared by bonding a 1 x 12-inch foil strip to 6 inches of a 1 x 8-inch graphite/epoxy specimen. The test was performed by securing the test specimen in a floating roller peel apparatus (Figure A-2), and applying the test load to the flexible (foil) adherend (Figure A-3). The test load was applied at a constant cross-head rate of 6.0 inches per minute. Throughout the test, a continuous autographic recording of applied load versus cross-head displacement was obtained. In reducing the data to establish the minimum, maximum and average peel strengths, the initial one-inch of peel was discounted.

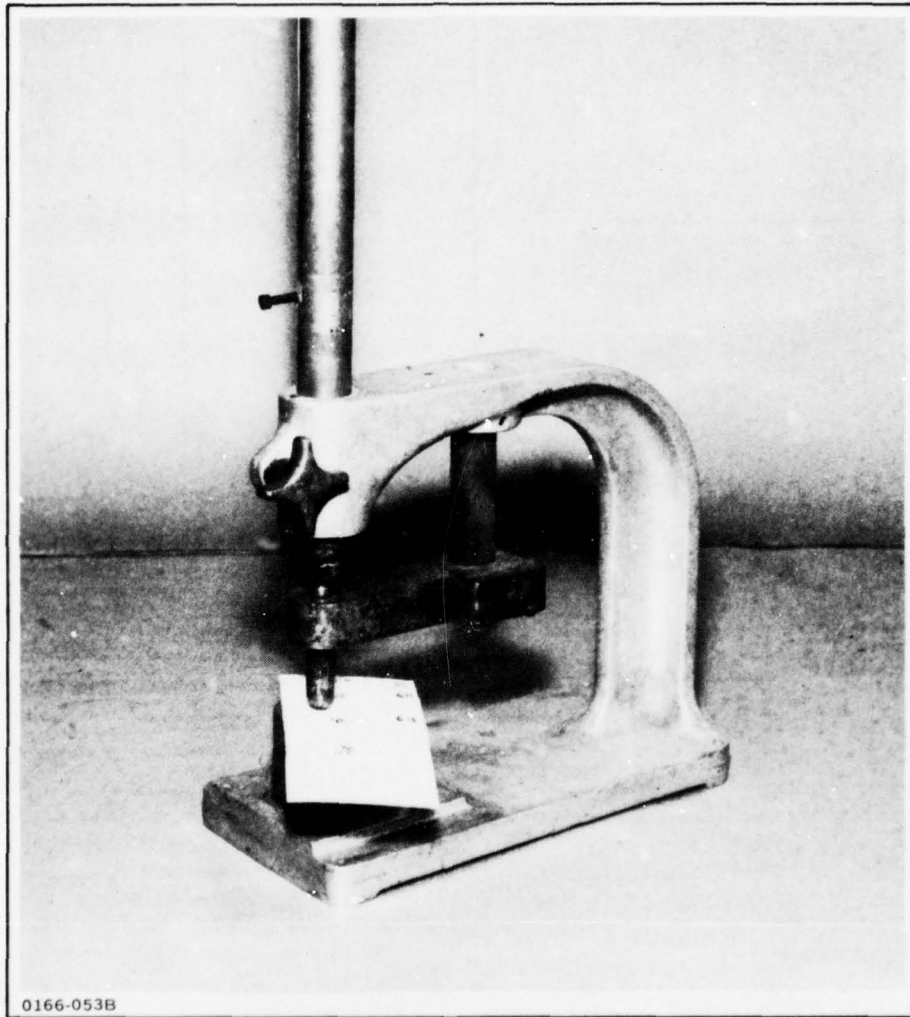

Figure A-1 Variable Impact Tester

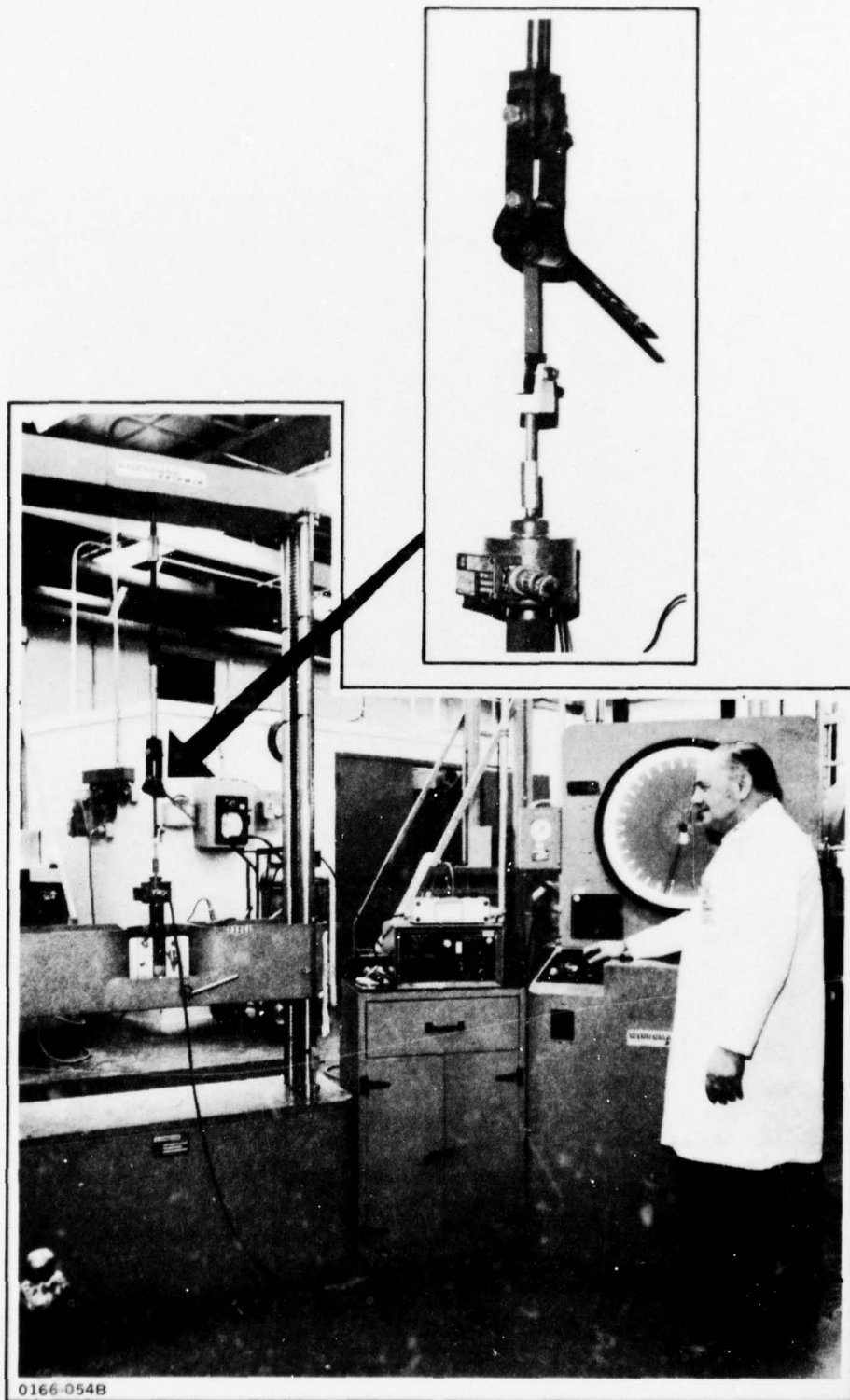

Figure A-2 Bell Method Peel Test Setup

A.4 FLEXURAL AND HORIZONTAL SHEAR STRENGTHS

Uniform cross-section rectangular bar flexure and horizontal shear specimens were tested as simple beams at span-to-depth ratios of 32 to 1 and 5 to 1, respectively, under single-point, center-loading (Figures A-4a and A-4b). The procedures followed were essentially those of ASTM D-790 and D-2344, respectively. The test load was applied at a constant cross-head rate of 0.05 inch per minute. Center deflection was autographically recorded concurrent with load application. Flexural moduli were established from load-center deflection relationships.

The 260°F elevated-test temperature was provided by large-volume circulating-air chambers that mated with the universal testing machines. Specimen temperature readings were obtained by thermocouples attached to each specimen. High-temperature LVDT deflectometers were used to measure flexural deflection. Semi-annual instrument calibration is performed on this equipment according to the procedures of ASTM E-83.

The unconditioned control specimens were soaked at the 260°F test temperature for 30 minutes prior to loading. To maintain the moisture level in the specimen for the duration of the test, the conditioned specimens were soaked at 260°F for only two minutes prior to being loaded. Grumman's experience has repeatedly demonstrated that for static tests, such as those performed under this study, the magnitude of the diffusion coefficient and the long duration required to desorb a significant amount of water in epoxy matrices are such that the moisture condition can be maintained by performing the test in ambient air without active moisture control. For example, 16-ply ITRI-type compression specimens of AS/3501-5A graphite/epoxy retained 91% of their pre-conditioning moisture after 5 to 7 minutes at 260°F.

A.5 FATIGUE

The fatigue specimens were tested under fully reversed bending ($R = -1$) as end-loaded, cantilever beams (Figure A-4c). The specimens were 0.25-inch-wide by 4-inch-long uniform, rectangular cross-section bars. Fatigue tests were performed on constant-load (rotating mass), Sonntag Model SF-2U universal fatigue machines. These machines are verified semi-annually using procedures commensurate with ASTM E-4.

Test methodology was developed to establish the test conditions for the control specimens, including limit stress (90 KSI) and an arbitrary cut-off of 100,000 cycles of reversed bending. Development of the methodology involved static and fatigue testing of a control specimen to establish a calibration of the test procedure.

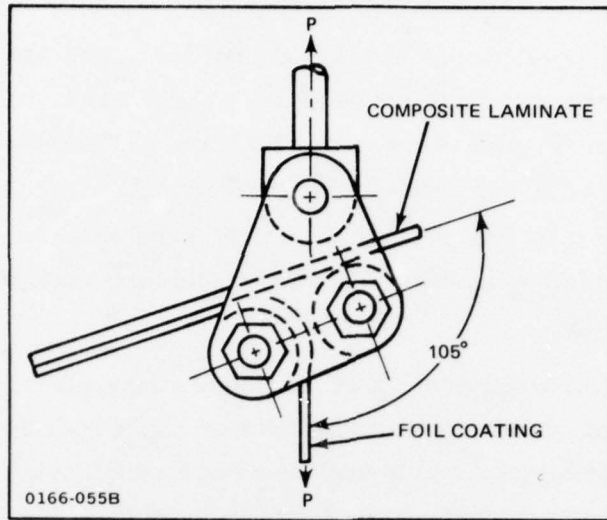

Figure A-3 Floating Roller Peel Test Configuration

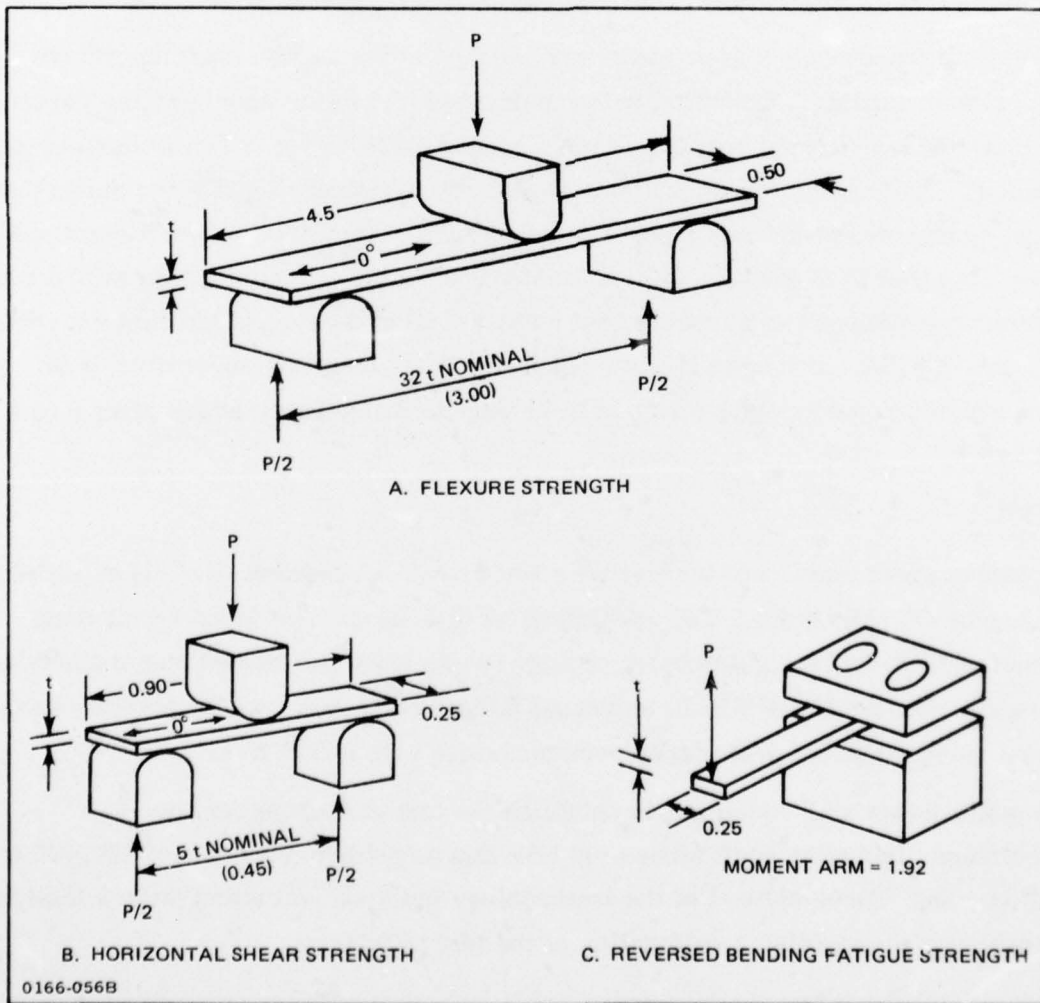

Figure A-4 Specimen/Test Configurations

One control specimen was instrumented with a bonded-on resistance-type strain gage and tested statically as an end-loaded, cantilever beam. During the test, the strain and specimen deflection at the point of loading were autographically recorded as a function of applied load. Calculations predicted that under limit load a strain of $11,540\mu$ inch/inch would occur at the point of maximum strain and $10,460\mu$ inch per inch at the strain gage. The measured strain was $10,760\mu$ inch/inch which was considered to be in excellent agreement with that predicted. The measured deflection at limit load was 0.42 inch. During the fatigue tests to limit load, the total amplitude (twice the static deflection) was measured and found to be 0.84 inch which established excellent agreement between the static and fatigue tests and verified the fatigue test methodology. During subsequent fatigue tests on control specimens at stresses lower than limit, the total amplitude was measured and compared to the deflections of the static calibration run. Excellent agreement was maintained.

The cyclic load for a given stress level was established for the control specimens in the fatigue tests and then maintained constant for the coated specimen tests, regardless of coating system. Initially, limit stress (90 KSI) was applied to the control specimens. However, the outer ± 45 -degree plies separated at the interface with the 0-degree plies before cut-off was achieved. To achieve cut-off, the stress was incrementally reduced over the course of testing a series of specimens from limit to 60 ksi. At intermediate stresses of 80 and 70 ksi, the ± 45 -degree plies continued to separate. As the applied stresses were lowered, the number of cycles at which ply separation occurred increased. The ply separation at these relatively low stresses is attributed to profound edge effects in the narrow specimen tested.

A.6 EMI SHIELDING EFFECTIVENESS

Shielding effectiveness was measured using Grumman's shielding effectiveness facility (Figure A-5). This facility was designed so that shielding effectiveness measurements for low-impedance (H), high-impedance (E) and plane-wave fields above 100 MHz can be obtained from one fixture. A two-pair antenna system was employed in this facility. Of the four compartments in the test fixture, one pair was used to obtain a reference with no sample mounted in the aperture. The sample was mounted in the aperture of the other pair of compartments. Both pairs of compartments were identically constructed. The measurement of shielding effectiveness (Figure A-6) was made by first taking a reference reading in the two compartments with the naked aperture and then taking a measurement in the other two compartments with the sample mounted in the aperture. The difference in decibels (dB)

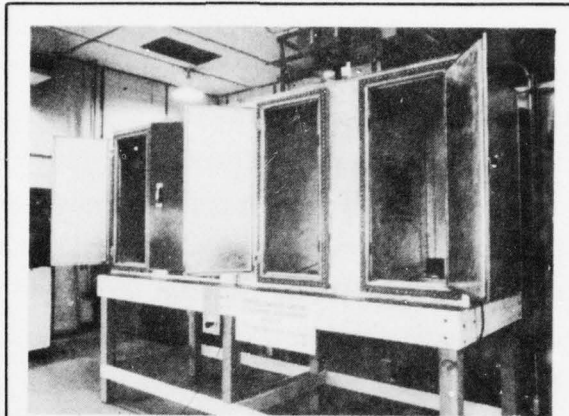

A. OVERALL VIEW

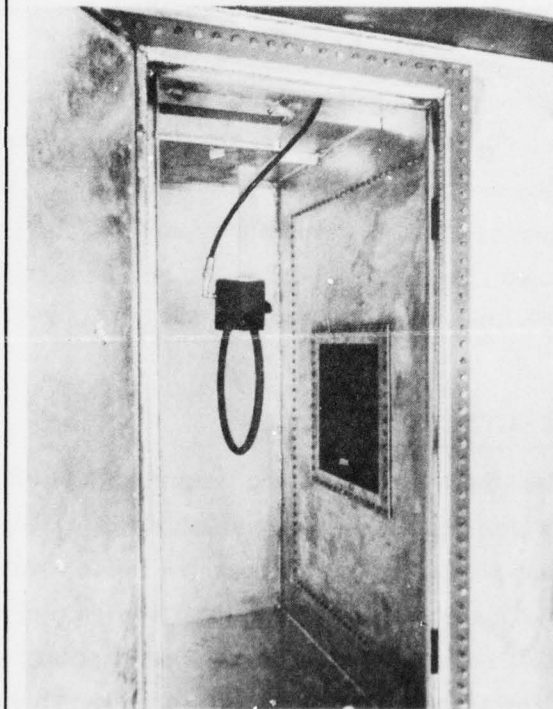

B. TEST CHAMBER

0166-057B

Figure A-5 EMI Shielding Effectiveness Facility

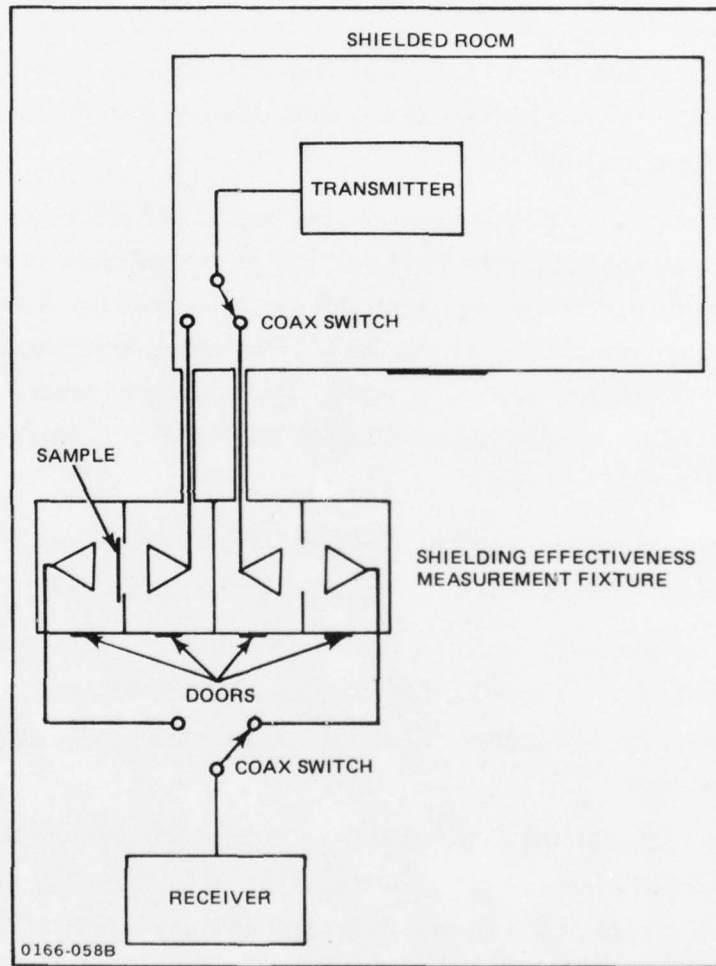

Figure A-6 Shielding Effectiveness Measurement Set-Up

of the two readings was the shielding effectiveness of the material under test. Each pair of transmitting antennas and receiving antennas was checked for equivalency to ensure that conditions were the same in each pair of compartments.

Measurements of the near-field E and H shielding effectiveness were made using the equipment listed in Figure A-7. The distance from the transmitting antenna to the sample shield was less than $\lambda/2\pi$ inches, to ensure true electric and magnetic near fields. The same transmitting and receiving equipment was used for plane waves; however, the distances between the transmitting antenna and the sample was greater than $\lambda/2\pi$ inches for electrically small antennas and $2D^2/\lambda$ inches for larger antennas where D was the largest dimension of the transmitting element.

A two-part electrical checkout of the system was performed prior to testing. Antenna equivalency was verified by comparing the field strength of two antennas in a particular field type (E, H or plane). Antennas that agree within two decibels are considered to be equivalent. The enclosure was checked for RF leaks by making a shielding effectiveness measurement of a 0.125-inch-thick aluminum panel. If there are no leaks, only the internal noise of the receiver is observed when the shielding of the 0.125-inch-thick aluminum panel is measured.

To ensure that only the electromagnetic shielding characteristics of the candidate protection systems were measured, the following precautions were taken:

- The candidate protective systems on each 15 x 15-inch graphite/epoxy sample were peripherally framed by a 1-1/2-inch-wide, electrically continuous coating intimately contacting the graphite fibers around the edge and on both sides of each sample (Figure A-8)
- All apertures, both external and internal, were hardened by installing a 1/4 inch x 3/16-inch RF metal gasket, Type 20-40118 (Tecknit Corporation), at a distance of 1/2 inch from the edge of the opening in a rigid recessed groove. The external doors were fabricated by the Universal Shielding Corporation and were of the UQ904 type, which electrically seal the enclosure against RF leakage
- The 15 x 15-inch graphite/epoxy sample was installed in the enclosure system in such a manner that the electrically continuous picture frame firmly contacted the RF gasket around the 12 x 12-inch aperture. To accomplish this, a metal frame or pressure plate was installed over the sample and bolted to the mount; this provided an even distribution of pressure upon the samples mounted against the RF gasket and apertures of the two enclosure systems.

TYPE OF FIELD	ANTENNA		DISTANCE FROM TRANSMITTING ANTENNA TO SAMPLE	FREQUENCY RANGE MHz
	RECEIVING	TRANSMITTING		
E-ELECTRIC (HIGH IMPEDANCE)	VR 105 36" ROD	36" ROD	3"	0.014-0.15
	VA 105 36" ROD	36" ROD	3"	0.15-10
	3" ROD	3" ROD	3"	100
	1" ROD	1" ROD	1"	1K
	1/8" ROD	1/8" ROD	1/8"	10K
H-MAGNETIC (LOW IMPEDANCE)	1 TURN 3" LOOP	1 TURN 3" LOOP	3"	0.014-100
	1 TURN 1" LOOP	1 TURN 1" LOOP	1"	1K
	1 TURN 1/8" LOOP	1 TURN 1/8" LOOP	1/8" LOOP	10K
PLANE WAVE (377 Ω)	3" ROD	3" ROD	32"	100
	1" ROD	1" ROD	12"	1K
	1/8" ROD	POLORAD CA-Y	12"	10K

0166-059B

Figure A-7 Shielding Effectiveness Measurement Equipment

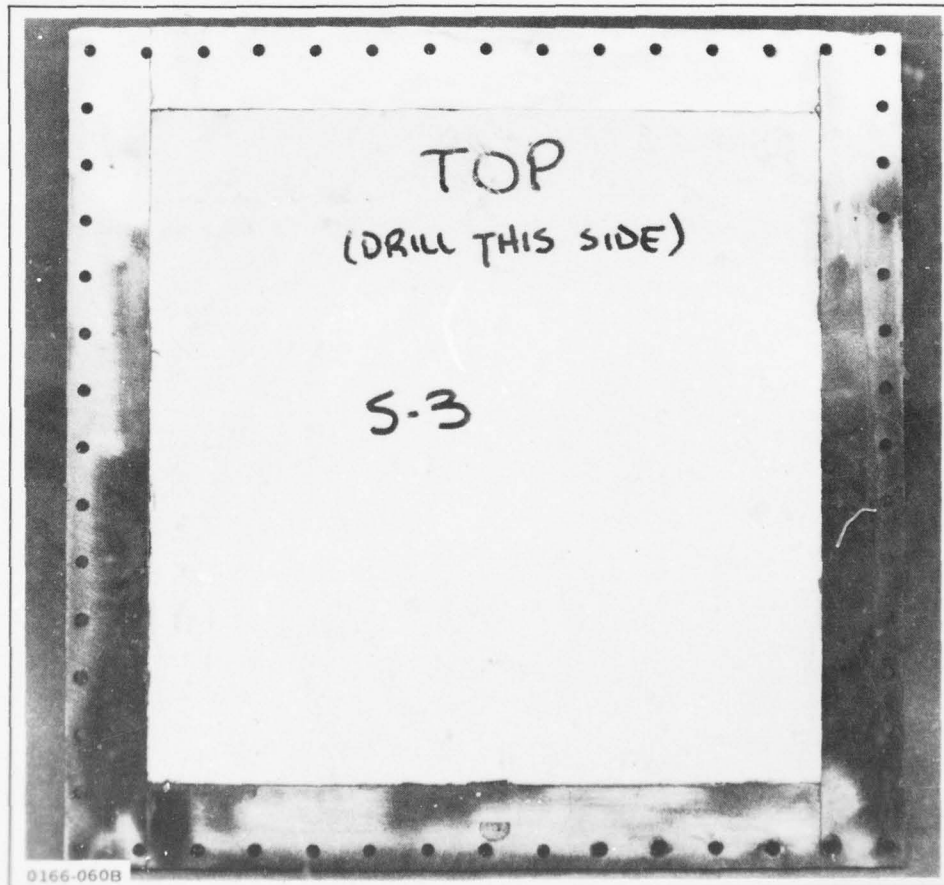

0166-060B

Figure A-8 EMI Test Panel with Edge Treatment

Together, these precautions guarded against RF leakage, while providing intimate electrical continuity between the graphite/epoxy samples and the shielding effectiveness measurement fixture. The edge treatment used to frame the specimens peripherally with an electrically continuous coating was applied to each of the 15 x 15-inch shielding effectiveness specimens. All edges were chamfered $3t \times t/2$ (where "t" is the panel thickness) on both sides, creating a knife edge which effectively exposed six-times the original fiber end cross-sectional area. A thin continuous layer of silver-filled conductive epoxy was applied in a 1.5-inch-wide strip on both sides around the periphery. The epoxy was covered with a layer of 0.010-inch-thick aluminum foil and the system was cured for two hours at 140°F.

APPENDIX B
DISTRIBUTION

DISTRIBUTION

COPIES

Naval Air Propulsion Test Center
Trenton, NJ 08628
ATTN: Mr. J. Glatz

Naval Ship R&D Center
Annapolis, MD 21402
ATTN: Mr. M. Silvergleit (Code 2823)

Commander
U. S. Naval Weapons Center
China Lake, CA 92555

Celanese Research Company
Box 1000
Summit, NJ 07901
ATTN: Mr. R. J. Leal

Naval Ship Engineering Center
Code 6101E
Navy Department
Washington, DC 20360

Naval Sea Systems Command
Code SEA-035
Washington, DC 20360

NASA Headquarters
Code RV-2 (Mr. N. Mayer)
600 Independence Ave., SW
Washington, DC 20546

The Boeing Company
Aerospace Division
P. O. Box 3707
Seattle, WA 98124

Boeing-Vertol Co.
P. O. Box 16858
Philadelphia, PA 19142
ATTN: Dept 1951

Commander
Naval Air Development Center
Warminster, PA 18974
ATTN: Aero Materials Dept
Aero Structures Dept
Radomes Section

DISTRIBUTION (cont.)

	<u>COPIES</u>
U. S. Army Air Mobility R&D Laboratory Fort Eustis, VA ATTN: SAVDL-EU-SS (Mr. J. Robinson)	1
B. F. Goodrich Aerospace & Defense Products 500 South Main Street Akron, OH 44318	1
Great Lakes Research Corporation P. O. Box 1031 Elizabethton, TN	1
Lockheed California Co. Box 551 Burbank, CA 91520 ATTN: Mr. J. H. Wooley	1
Lockheed Missiles & Space Co. Sunnyvale, CA 94088 ATTN: Mr. H. H. Armstrong, Dept. 62-60	1
TRW, Inc 23555 Euclid Ave Cleveland, OH 44117	1
E. I. DuPont de Nemours & Co. Textile Fibers Dept Wilmington, DE 19898 ATTN: Mr. C. Zweben	1
Bell Aerospace Co. Buffalo, NY 14240 ATTN: Mr. F. M. Anthony	1
Union Carbide Corporation Chemicals and Plastics One River Road Bound Brook, NJ 08805	1
General Dynamics Convair Aerospace Division P. O. Box 748 Ft. Worth, TX 76101 ATTN: Tech Library	1
General Dynamics Convair Division P. O. Box 1128 San Diego, CA 92138 ATTN: Mr. W. Scheck; Dept. 572-10	1

DISTRIBUTION (cont.)

	<u>COPIES</u>
Director Plastics Technical Evaluation Center Picatinny Arsenal Dover, NJ 07801	1
The Rand Corporation 1700 Main Street Santa Monica, CA 90406	1
HITCO 1600 W. 135th St. Gardena, CA 90406	1
AVCO Corporation Applied Technology Division Lowell, MA 01851	1
Department of the Army Army Materials & Mechanics Research Center Watertown, MA 02172	1
North American Aviation Columbus Division 4300 E. Fifth Avenue Columbus, OH 43216	1
Rockwell International Corp 12214 Lakewood Blvd Downey, CA 90241 ATTN: Mr. C. R. Rousseau	1
McDonnell-Douglas Corporation Douglas Aircraft Company 3855 Lakewood Blvd Long Beach, CA 90801 ATTN: Mr. R. J. Palmer	1
General Electric Company Valley Forge Space Center Philadelphia, PA 19101	1
Monsanto Research Corporation 1515 Nicholas Road Dayton, OH 45407	1
Material Sciences Corporation 1777 Walton Road Blue Bell, PA 19422	1

DISTRIBUTION (cont.)

COPIES

Naval Air Systems Command Washington, D.C. 20361 ATTN: AIR-954 FOR DISTRIBUTION AS FOLLOWS: AIR-52032D (3 copies) AIR-954 (6 copies)	9
Office of Naval Research (Code 472) Washington, D.C. 20350	1
Office of Naval Research, Boston 405 Summer Street Boston, MA 02210 ATTN: Dr. L. H. Peebles	1
Naval Research Laboratory (Code 6306 and 6120) Washington, DC 20350	2
Naval Ordnance Laboratory Code 234 White Oak, Silver Spring, MD 20910	1
Air Force Flight Dynamics Laboratory Wright-Patterson Air Force Base, OH 45433 ATTN: LC 1 LN 1 LTF 1 LAE 1	4
Air Force Flight Dynamics Laboratory Wright-Patterson Air Force Base, OH 45433 ATTN: FDTC	1
Defense Ceramic Information Center Battelle Memorial Institute 505 King Avenue Columbus, OH 43201	1
Illinois Institute of Technology Research Institute 10 West 35th Street Chicago, IL 60616 ATTN: Dr. R. Cornish	1
Brunswick Corporation Technical Products Division 325 Brunswick Lane Marion, VA 24354	1

DISTRIBUTION (Cont.)

	<u>COPIES</u>
Naval Ship Research & Development Center Washington, DC ATTN: Mr. M. Krenzke, Code 727	1
NASA Lewis Research Center 21000 Brookpark Road Cleveland, OH 44135	1
NASA Langley Research Center Hampton, VA	1
United Aircraft Corporation United Aircraft Research Laboratories E. Hartford, CT 06108	1
United Aircraft Corporation Pratt & Whitney Aircraft Division East Hartford, CT 06108	1
United Aircraft Corporation Hamilton-Standard Division Windsor Locks, CT ATTN: Mr. T. Zajac	1
United Aircraft Corporation Sikorsky Aircraft Division Stratford, CT 06602 ATTN: Mr. J. Ray	1
Union Carbide Corporation Carbon Products Division P. O. Box 6116 Cleveland, OH 44101	1
Philco-Ford Corporation Aeronutronic Division Ford Road Newport Beach, CA 92663	1
Vought Corporation Systems Division P. O. Box 5907 Dallas, TX 75222 ATTN: Mr. A. E. Hohman	1