

AD-A070 091

NAVAL POSTGRADUATE SCHOOL MONTEREY CA  
DESIGN STUDY OF A LOW PROFILE, HIGH FREQUENCY ANTENNA SYSTEM.(U)  
MAR 79 R E MASKELL

F/G 17/2.1

UNCLASSIFIED

NL

1 OF 1  
AD A070091

END  
DATE  
FILMED  
7-79  
DDC

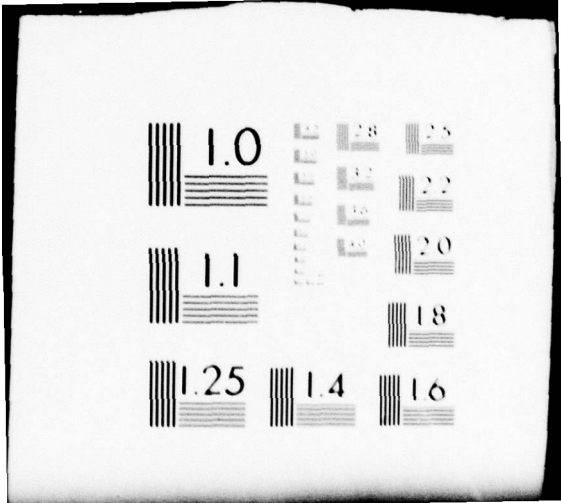

LEVEL #

②

# NAVAL POSTGRADUATE SCHOOL

Monterey, California

AD A 070091



DDC  
RECEIVED  
JUN 20 1979  
RESOLVED

## THESIS

A

DESIGN STUDY OF A LOW PROFILE, HIGH  
FREQUENCY ANTENNA SYSTEM

by  
Robert Emmett Maskell

March 1979

Thesis Advisor: O. M. Baycura

DDC FILE COPY

Approved for Public Release; Distribution Unlimited

79 06 20 076

UNCLASSIFIED

SECURITY CLASSIFICATION OF THIS PAGE (When Data Entered)

REPORT DOCUMENTATION PAGE		READ INSTRUCTIONS BEFORE COMPLETING FORM
1. REPORT NUMBER	2. GOVT ACCESSION NO.	3. RECIPIENT'S CATALOG NUMBER
4. TITLE (and Subtitle) 6 Design Study of a Low Profile, High Frequency Antenna System		5. TYPE OF REPORT & PERIOD COVERED 9 Master's Thesis March 1979
7. AUTHOR(s) 10 Robert Emmett/Maskell		6. PERFORMING ORG. REPORT NUMBER
8. PERFORMING ORGANIZATION NAME AND ADDRESS Naval Postgraduate School Monterey, California 93940		9. CONTRACT OR GRANT NUMBER(s)
10. CONTROLLING OFFICE NAME AND ADDRESS Naval Postgraduate School Monterey, California 93940		11. PROGRAM ELEMENT, PROJECT, TASK AREA & WORK UNIT NUMBERS 12 59a
11. CONTROLLING OFFICE NAME AND ADDRESS Naval Postgraduate School Monterey, California 93940		12. REPORT DATE 17 March 1979
14. MONITORING AGENCY NAME & ADDRESS (if different from Controlling Office)		13. NUMBER OF PAGES 58
		15. SECURITY CLASS. (of this report) Unclassified
		15a. DECLASSIFICATION/DOWNGRADING SCHEDULE
16. DISTRIBUTION STATEMENT (of this Report) Approved for Public Release; distribution unlimited		
17. DISTRIBUTION STATEMENT (of the abstract entered in Block 20, if different from Report)		
18. SUPPLEMENTARY NOTES		
19. KEY WORDS (Continue on reverse side if necessary and identify by block number) ANTENNA HIGH FREQUENCY RADIO		
20. ABSTRACT (Continue on reverse side if necessary and identify by block number) This paper presents a design study of one method of reducing the physical size of high frequency radio antennas. The particular method utilized is that of the normal mode helical antenna. The results of tests conducted during December 1978 and January/February 1979 are listed and discussed and recommended design improvements are provided.		

251 450

1013

Approved for Public Release; distribution unlimited

DESIGN STUDY OF A LOW PROFILE, HIGH  
FREQUENCY ANTENNA SYSTEM

by

Robert Emmett Maskell  
Lieutenant, United States Navy  
B.S.O.E., United States Naval Academy, June 1973

Submitted in partial fulfillment of the  
requirements for the degree of

MASTER OF SCIENCE IN ELECTRICAL ENGINEERING

from the

NAVAL POSTGRADUATE SCHOOL  
March 1979

Accession For	
NPIS G.N&I	<input checked="" type="checkbox"/>
DSC TAB	<input type="checkbox"/>
Unannounced Justification	<input type="checkbox"/>
By _____	
Distribution/_____	
Availability Codes	
Dist	Avail and/or special
A	

Author

Robert E. Maskell

Approved by:

O. W. Baycura

Thesis Advisor

Milton L. Wilcox

Second Reader

W. K. Kirk

Chairman, Department of Electrical Engineering

William M. Tolles

Dean of Science and Engineering

## ABSTRACT

This paper presents a design study of one method of reducing the physical size of high frequency radio antennas. The particular method utilized is that of the normal mode helical antenna. The results of tests conducted during December 1978 and January/February 1979 are listed and discussed and recommended design improvements are provided.

TABLE OF CONTENTS

A. INTRODUCTION- - - - -	7
B. INITIAL DESIGN- - - - -	9
C. IMPROVED DESIGN - - - - -	17
D. TOP LOADING MODIFICATION- - - - -	30
E. RETEST OF INITIAL DESIGN- - - - -	38
F. ANALYSIS OF RESULTS - - - - -	41
G. CONCLUSIONS AND RECOMMENDATIONS - - - - -	46
APPENDIX A- - - - -	50
BIBLIOGRAPHY- - - - -	56
INITIAL DISTRIBUTION LIST - - - - -	58

LIST OF TABLES

1.	Test Results Of Initial Antenna Design, 9.5 Turn Helix- - - - -	13
2.	Center To Center Conductor Spacing Required For Circular Polarization With A Constant Helix Diameter Of .7 Meters - - - - -	19
3.	Test Results Of Improved Design Antenna, 6.75 Turn Helix - - - - -	23
4.	Test Results Of 6.75 Turn Helix With .61 Meter "Top Hat" Loading - - - - -	31
5.	Test Results Of 6.75 Turn Helix With .91 Meter "Top Hat" Loading - - - - -	35
6.	Results Of Retest Of 9.5 Turn Helix - - - - -	39
7.	Theoretical Efficiency Of 6.75 Turn Helical Antenna .7 Meters In Diameter - - - - -	44

## LIST OF FIGURES

1. Diagram Of Initial Antenna- - - - -	11
2. Test Results Of 9.5 Turn Helix (3.5-6.0 MHz)- - - -	14
3. Test Results Of 9.5 Turn Helix (6.5-17.8 MHz) - - -	15
4. Axial Ratio Versus Frequency For Turn Spacing Of 120 Millimeters on .7 Meter Diameter Helix - - -	21
5. Test Results Of 6.75 Turn Helix (4.5-6.5 MHz) - - -	25
6. Test Results Of 6.75 Turn Helix (6.875-11.5 MHz)- -	26
7. Test Results Of 6.75 Turn Helix (12.0-15.75 MHz)- -	27
8. Test Results Of 6.75 Turn Helix (15.5-20.0 MHz) - -	28
9. Test Results Of 6.75 Turn Helix (20.0-40.0 MHz) - -	29
10. Test Results Of 6.75 Turn Helix With .61 Meter Top Hat (4.0-6.0 MHz) - - - - -	32
11. Test Results Of 6.75 Turn Helix With .61 Meter Top Hat (8.0-30.0 MHz)- - - - -	33
12. Test Results Of 6.75 Turn Helix With .61 Meter Top Hat (4.0-9.0 MHz) - - - - -	36
13. Test Results Of 6.76 Turn Helix With .61 Meter Top Hat (10.0-30.0 MHz) - - - - -	37
14. Results Of Retest Of 9.5 Turn Helix - - - - -	40
A-1 Diagram Of Test Equipment Set-Up - - - - -	51
A-2 Example Of Plotting $1 + \rho$ On Smith Chart - - - - -	52
A-3 Example Of Plotting The Complex Impedance Using The Method Described - - - - -	55

## A. INTRODUCTION

Although satellite communications has become the primary mode for long haul military communications, a definite requirement still exists for high frequency radio circuits. The vulnerability of the satellite to jamming and premature failure makes back-up paths essential. Because of the critical nature of these secondary circuits, they must be both efficient and reliable. The weakest component, over which the engineer has control, is usually the antenna system. The lack of "glamour and excitement" in the field of electromagnetics and antenna design has caused it to lag behind the "state-of-the-art" in other areas of communications engineering.

The United States Navy has, historically, used 28 and 35 foot whip antennas and various types of broadband, long-wire antennas for high frequency operation. These types of antennas take up large amounts of space, are difficult to maintain, provide very limited off-frequency isolation and are extremely vulnerable to damage from weather and blast effects. Whip antennas located near the edge of flight decks also suffer from having to be lowered during flight operations. A physically small, tunable high frequency antenna is, thus, a desirable product, especially for shipboard use. The normal mode, tunable helix antenna shows considerable promise as a replacement for presently used high frequency antennas

and has been investigated to a limited extent, most recently by Rockway, et. al. [11]

The axial (end-fire or beam) mode helical antenna has been studied extensively for use at ultra-high frequencies and is an important component of many satellite communications systems. It enjoys the advantages of high directional gain in a relatively small space and it is circularly polarized. Circular polarization is useful in overcoming fading induced by ionospheric effects and will be discussed further in another section of this paper. The axial mode exists for helical antennas when the circumference of the helix is between .8 and 1.3 wavelengths. [7] The normal mode (greatest radiation in a direction normal to the axis of the helix) exists when the circumference is less than about .2 wavelengths.

It is the purpose of this paper to further pursue the design and testing of a normal mode, tunable helix antenna with a nominal radiation resistance of 50 ohms. The antenna is to operate over as much of the high frequency spectrum (3 to 30 Megahertz) as possible and should cover, at least, the range from 6 to 20 Megahertz without requiring excessive external tuning. Physical dimensions should not exceed one meter, both in height and diameter. These design criteria are arbitrarily chosen to provide reasonable high frequency spectrum coverage with a device which takes up a relatively small amount of space.

## B. INITIAL DESIGN

The most serious disadvantage of all small antennas is their inherently small radiation resistance and resulting low efficiency. The helix represents one method of increasing the efficiency of an electrically small antenna through two different approaches. The first, suggested by Li [8], is to excite the helix as a folded dipole. This approach was followed by Venum [15] with limited success. The other method is to increase the number of turns and/or increase the diameter of the helix. This was postulated by Smith [13] and used by Rockway [11] with generally good results. Since the second method has shown better experimental results, and since the physical size limitations imposed are not too severe, it was decided to pursue this method.

The first experimental antenna was built using a shape which approached the limits established for size. It consisted of a fiberglass form one meter in height and .7 meters in diameter. This form was selected simply on the basis of availability (it was a surplus radome sitting in the laboratory). It was wrapped with 25.4 millimeter wide copper tape in a helix having a pitch angle of 1.3 degrees and a center to center conductor spacing of 50 millimeters. The spacing was chosen to exceed the theoretical minimum spacing of 1.5 times the conductor diameter specified by Smith [13] required to eliminate serious proximity effects on the currents in each conductor. Conductor diameter for the copper tape is

equal to the width of the tape. Although Rockway [11] states that flat conductors do not suffer from proximity effects, this spacing was chosen to keep the design on the conservative side. Additionally, a round conductor with diameter equal to the tape width can be substituted directly without having to be compensate for conductor spacing. This substitution results in a three-fold increase in efficiency of the antenna, according to the experimental result of Bohley [2]. The tape was wound around the form in a counter-clockwise direction for a total of 9.5 turns with the upper end on the opposite side from the bottom termination (see Figure 1). This was the maximum number of turns which could be placed on this form within the constraints of conductor spacing.

The total length of the copper conductor was 20.9 meters. Rockway [11] has demonstrated that the first resonant frequency of a normal mode helix can be predicted by the equation:

$$L/\lambda = X \quad (1)$$

where  $L$  = total conductor length (meters)  
 $\lambda$  = wavelength of first resonant frequency (meters)  
 $X$  = Dimensionless constant

Rockway [11] determined empirically that  $X$  is approximately .36 which leads to the following equation:

$$f = .36c/L \quad (2)$$

where  $f$  = first resonant frequency (MHz)  
 $c$  = velocity of light (m/sec)

← .7 M →

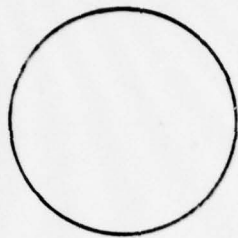

TOP  
VIEW

↑  
1 M  
↓



SIDE  
VIEW

Figure 1  
DIAGRAM OF INITIAL ANTENNA

The above assumes that the velocity of propagation along the helical conductor is equal to the velocity of light in free space. While this is not exact, it suffices for a first approximation. Using the above development, the first resonant frequency of the initial design was predicted to be 5.17 MHz.

All test measurements were made during clear weather with the antenna mounted on an 11 by 11 meter aluminum ground plane located on the roof of Spanagel Hall, Naval Postgraduate School, Monterey, California. A Hewlett-Packard HP 8405A Vector Voltmeter and an AN/URM-25 Signal Generator were utilized in the set-up shown in Figure A-1 to measure the complex impedance and voltage standing wave ratio (VSWR) of the antenna. The test procedure used was that provided by Hewlett-Packard. [4] (See Appendix A)

Several difficulties were encountered during this initial testing period, the most serious of which was discovery of a gross inaccuracy in the vector voltmeter. Additional problems encountered were related to the construction of both the antenna and the ground plane. The copper tape on the antenna was damaged in several places due to careless handling and the connector at the ground plane was found to be making good contact only intermittently.

The results of initial testing of this antenna are summarized in Table 1 and Figures 2 and 3. These results seemed too good to be true at some frequencies and, near 10 MHz, they showed a negative real part of impedance. This prompted a

TABLE 1  
 Test results of initial antenna design,  
 9.5 turn helix\*

Frequency (MHz)	Impedance (50ΩSystem)	VSWR
3.5	73.2 - j139.6	7.33
4.0	19.7 - j78.1	9.0
4.25	2.8 - j80.0	65.67
4.5	19.5 - j23.0	3.17
4.6	53.7 - j36.0	1.99
5.0	60.0 - j52.6	2.57
5.5	57.2 - j66.2	3.26
6.0	114.2 - j137.4	5.90
6.5	101.7 - j125.7	5.45
7.0	83.0 - j138.0	6.69
8.0	38.8 - j108.8	8.09
8.5	37.7 - j101.1	7.33
8.8	48.6 + j6.1	1.13
9.0	25.5 - j74.6	6.69
10.0**		
10.5**		
11.2	19.2 + j23.6	3.26
12.5	28.9 + j21.0	2.15
13.8	46.2 + j30.0	1.86
17.8	139.2 + j24.6	2.88

\* Data presented for comparison purposes only. Data not considered valid. See text for explanation.

\*\* Measurement showed negative real part of impedance which was considered in error and was not recorded.

IMPEDANCE OR ADMITTANCE COORDINATES

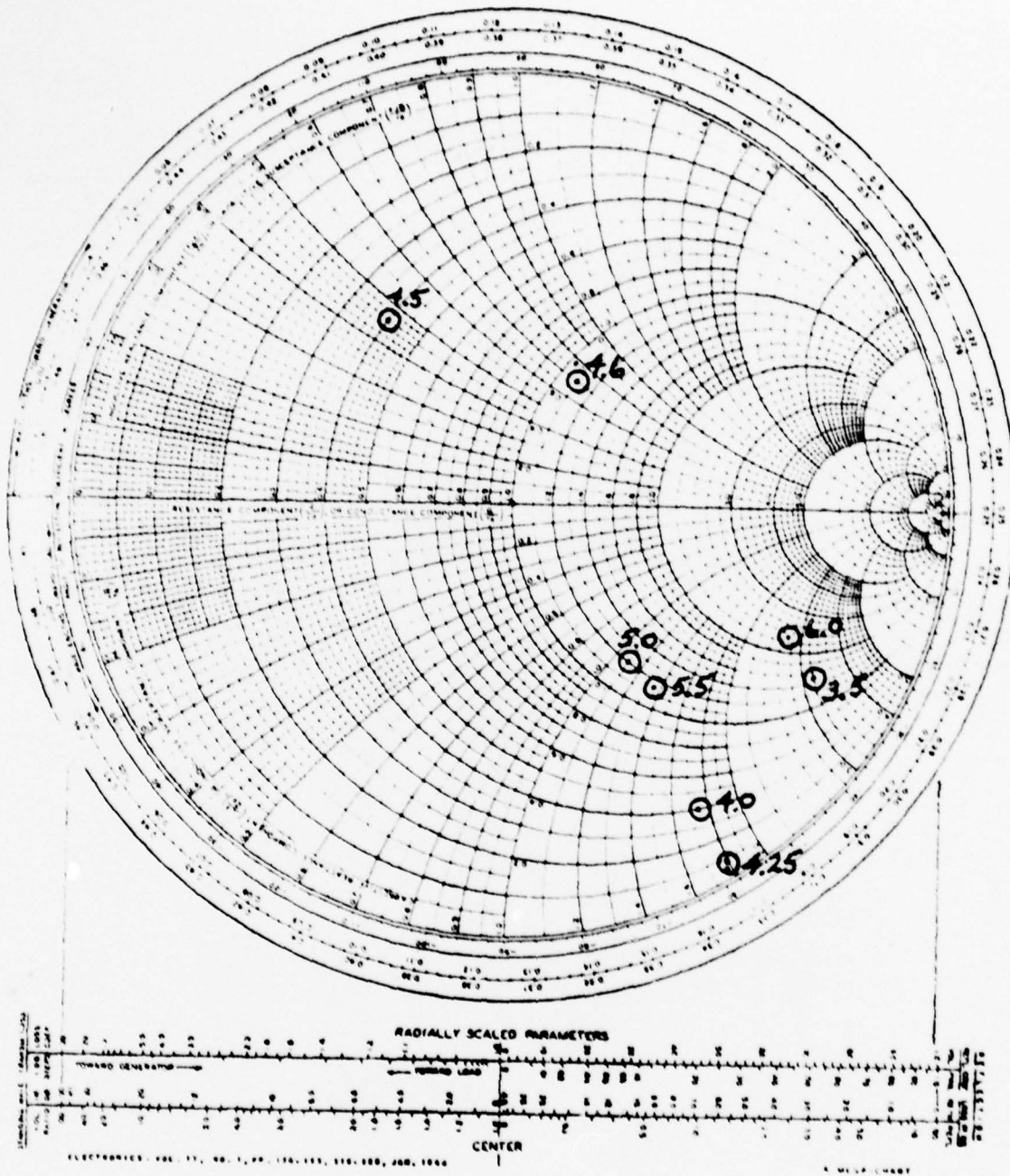

Figure 2  
 9.5 Turn Helix  
 (All Data Points Are MHz)



search for the errors which resulted in discovery of a bad phasemeter in the vector voltmeter. Although this initial test data is in error, it is included as part of the design refinement of the second antenna and as an example of the large errors which are possible with the test set-up used. It is believed that these problems were corrected by the construction of the second antenna.

### C. IMPROVED DESIGN

Using the same size fiberglass form as that used for the initial design, a second antenna was constructed. While the initial design objective was to put as many turns of copper tape on the form as possible, the next step was to reconfigure the antenna for circular polarization. A circularly polarized antenna is especially desirable at high frequencies since it will always show some coupling to a received signal regardless of its transmitted polarity or any changes in that polarity caused by ionospheric effects. It has been suggested that the use of circular polarization can reduce the incidence and severity of fading at high frequencies. Appleton [1] has provided a simple demonstration of the change from linear to circular polarization of a wave reflected from the ionosphere. This "sky wave" is the most important component of long distance communications at HF and its polarization at the receiving antenna has been shown to be a component of fading of the received signal. [10] The time varying properties of the ionosphere cause a corresponding variation in the coupling of a linearly polarized antenna to any signal reflected by the ionosphere. In contrast, a circularly polarized antenna will show a constant amount of coupling to all received signals and is, thus, a valuable component of high frequency communications systems.

For the normal mode helix, the far field components of

the radiation pattern are given by:

$$E_{\phi} = \frac{120\pi^2 \{I\} \sin\theta}{r} \frac{A}{\lambda^2} \quad (3)$$

and

$$E_{\theta} = j \frac{60\pi \{I\} \sin\theta}{r} \frac{S}{\lambda} \quad (4)$$

where  $\lambda$  = free space wavelength  
 $A$  = axial length =  $nS$   
 $I$  = magnitude of current on antenna  
 $n$  = number of turns  
 $\theta$  = azimuth angle in horizontal plane  
 $S$  = center to center spacing of turns  
 $r$  = radial distance from antenna

[7]

Since  $E_{\phi}$  and  $E_{\theta}$  are in phase quadrature, as noted by the  $j$  term, the ratio of the magnitudes gives the axial ratio of the polarization ellipse of the far field.

$$AR = \text{axial ratio} = \left| \frac{E_{\theta}}{E_{\phi}} \right| = \frac{S}{2\pi A} = \frac{2S\lambda}{\pi^2 D^2} \quad (5)$$

When  $|E_{\theta}| = |E_{\phi}|$ , the axial ratio is 1 and the polarization is circular. At all other axial ratios, the antenna is elliptically polarized with the major axis indicated by the magnitude of the axial ratio. When  $AR < 1$ , the major axis is horizontal and when  $AR > 1$ , the major axis is vertical. [7]

Setting the axial ratio equal to 1 gives:

$$\pi D = \sqrt{2S\lambda} \quad (6)$$

which can be used to solve for turn spacing ( $S$ ) at a given diameter ( $D$ ) and frequency for circular polarization. Table 2 gives the required spacing for various frequencies at a

TABLE 2

Center to center conductor spacing  
required for circular polarization  
with a constant helix diameter of  
.7 meters

<u>Frequency (MHz)</u>	<u>Spacing (mm)</u>	<u>Pitch angle (degrees)</u>
4.0	36.24	.84
4.5	36.27	.94
5.0	40.30	1.05
5.5	44.33	1.15
6.0	48.36	1.26
6.5	52.39	1.36
7.0	56.42	1.46
7.5	60.45	1.57
8.0	64.48	1.68
8.5	68.51	1.78
9.0	82.54	1.89
9.5	76.57	1.99
10.0	80.60	2.09
10.5	84.63	2.20
11.0	88.66	2.30
11.5	92.69	2.41
12.0	96.72	2.52
12.5	100.75	2.62
13.0	104.78	2.72
13.5	108.81	2.83
14.0	112.84	2.93
14.5	116.87	3.04
15.0	120.90	3.14
15.5	124.93	3.25
16.0	128.96	3.36
16.5	132.99	3.46
17.0	137.02	3.58
17.5	141.05	3.67
18.0	145.08	3.77
18.5	149.11	3.87
19.0	153.14	3.98
19.5	157.17	4.09
20.0	161.20	4.19

constant diameter equal to that used in the construction of the test antennas (.7 meters).

A turn spacing of 120 millimeters was selected to give circular polarization at 15 MHz with the major axis of the polarization ellipse vertical below 15 MHz and horizontal above that frequency. The relative amount of deviation from circular polarization can be seen in Figure 4. When reading this graph it should be kept in mind that pure vertical polarization corresponds to an axial ratio of infinity and pure horizontal polarization corresponds to an axial ratio of zero.

The original antenna was connected to the signal generator by a short piece of wire terminated in a round lug through which a screw was passed and threaded into the connector on the ground plane. The ground plane connector was attached to a section of coaxial cable with the outer conductor to the ground plane and the inner conductor to the device under test and to the signal generator. This design was conceived to facilitate laboratory work on antennas with threaded bases and is thought to be part of the problem encountered in taking the data in part B. The threaded part of the connector on the outside of the ground plane does not always make good contact with the section inside. For this reason, the second antenna was connected with a piece of RG-213/U coaxial cable with an N-type connector on one end and the center conductor of the other end soldered to the copper tape at its lowest point on the antenna. The outer

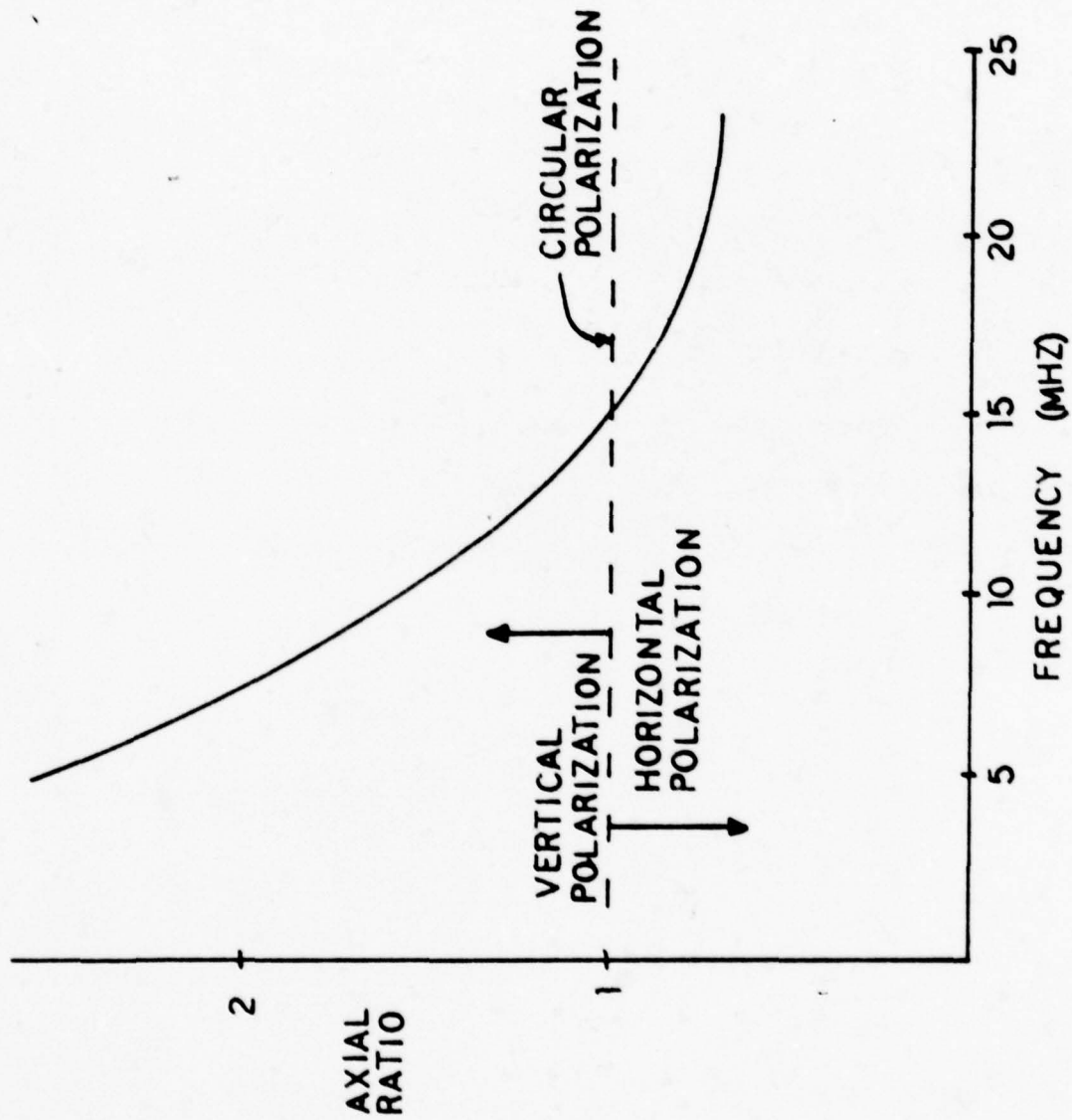

Figure 4  
FREQUENCY (MHz)

conductor was attached to the ground plane with copper tape. The antenna was then connected to the signal generator using a 39.32 meter long piece of RG-8A/U coaxial cable. (RG-213/U and RG-8A/U have the same characteristics and cause no mismatch error.) This configuration eliminates the earlier ambiguity introduced by the ground plane conductor.

This second antenna consisted of 6.75 turns of copper tape wound in a counter-clockwise direction around a fiberglass form identical to the first antenna. The total length of the copper conductor was 14.85 meters which results in a predicted first resonant frequency of 7.27 MHz using the previously described method of Rockway. [11].

Test data for this second antenna is as shown in Table 3 and Figures 5 through 9. As can be seen, the apparent first resonant frequency is at 6.26 MHz (about 1 MHz below predicted).

TABLE 3

## Test Results Of Improved Design Antenna, 6.75 Turn Helix

<u>Frequency (MHz)</u>	<u>Impedance (50<math>\Omega</math> System)</u>	<u>VSWR</u>
4.0	2.5 - j82.5	74.30
4.5	190.0 - j375.0	18.81
4.75	2.5 - j220.0	407.90
5.0	5.0 - j155.0	106.05
5.5	15.0 - j160.0	37.71
6.0	6.0 - j33.0	12.01
6.25	5.0 - j9.5	10.36
6.26	3.0 + j0	16.67
6.275	4.0 + j3.0	12.55
6.3	3.0 + j9.5	17.27
6.5	2.5 + j62.5	51.29
6.875	400.0 + j0	8.00
7.0	150.0 - j350.0	19.61
8.0	9.5 - j139.0	45.87
9.0	50.0 - j275.0	32.23
9.5	70.0 - j125.0	6.42
10.0	25.0 - j170.0	25.57
10.5	7.5 - j71.0	20.21
11.0	2.5 - j77.5	68.00
11.5	1.25- j60.0	97.90
12.0	2.5 - j65.0	53.90
12.5	1.25- j55.0	88.55
13.0	.05- j70.0	407.90
13.5	12.5 - j90.0	17.15
13.75	14.0 - j55.0	8.05
14.0	11.0 - j38.0	7.26
14.25	4.0 - j29.0	16.73
14.5	3.0 - j1.5	16.70
15.0	1.5 - j9.0	34.44
15.25	3.0 + j3.5	16.75

TABLE 3 continued

<u>Frequency (MHz)</u>	<u>Impedance (50<math>\Omega</math> System)</u>	<u>VSWR</u>
15.5	2.0 + j23.5	30.56
15.75	55.0 + j60.0	2.98
16.0	400.0 - j400.0	16.06
17.0	.50- j60.0	407.90
18.0	1.50- j67.5	94.33
19.0	5.5 - j38.5	14.52
20.0	3.0 - j26.0	21.19
24.5	2.5 + j4.0	20.11
25.0	6.5 + j.50	7.69
25.5	9.5 + j3.5	5.29
30.0	8.5 + j7.5	6.02
40.0	1.0 + j16.0	195.67



IMPEDANCE OR ADMITTANCE COORDINATES

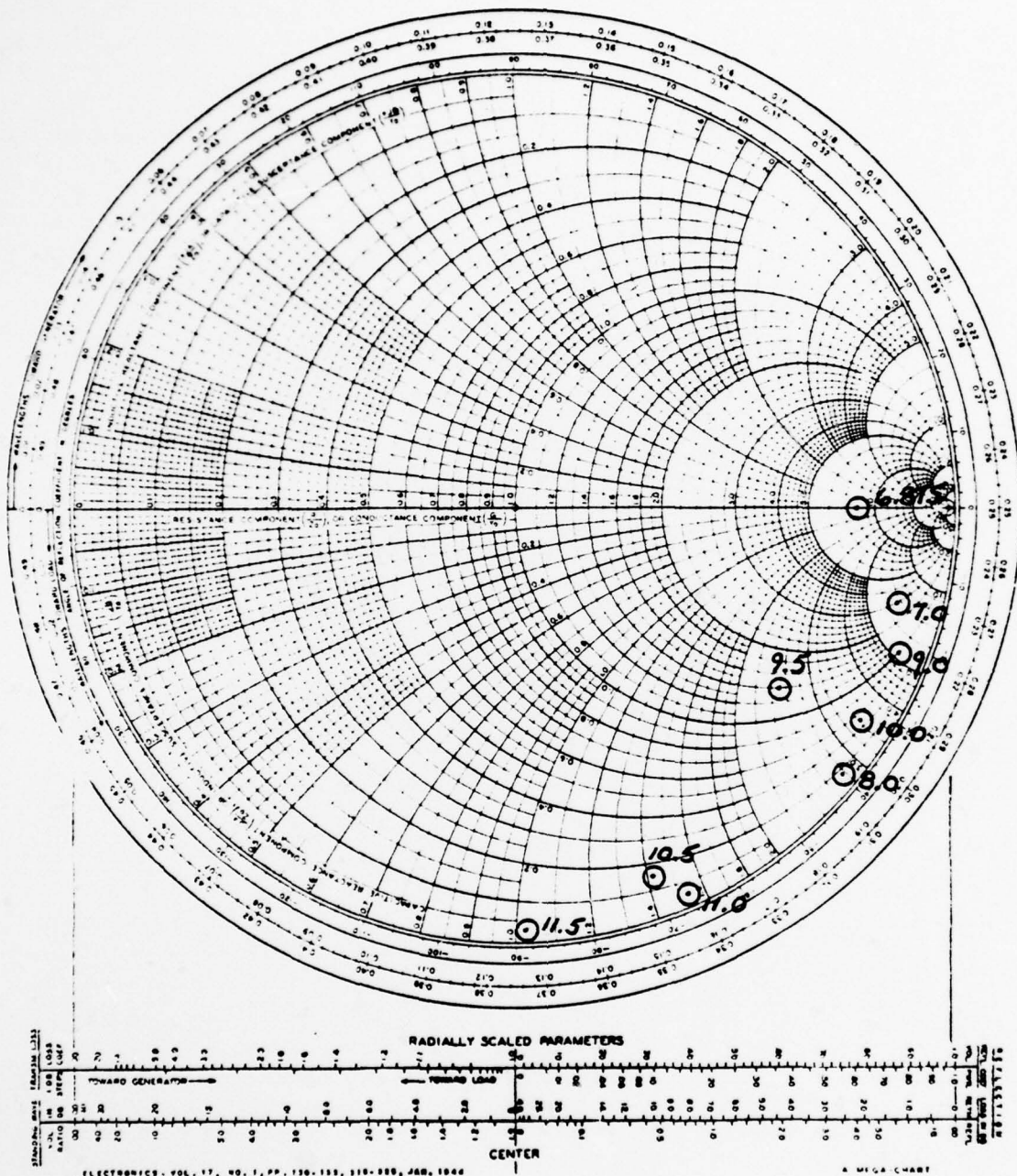

Figure 6  
 Rest Results  
 6.75 Turn Helix (Data Points In MHz)





IMPEDANCE OR ADMITTANCE COORDINATES

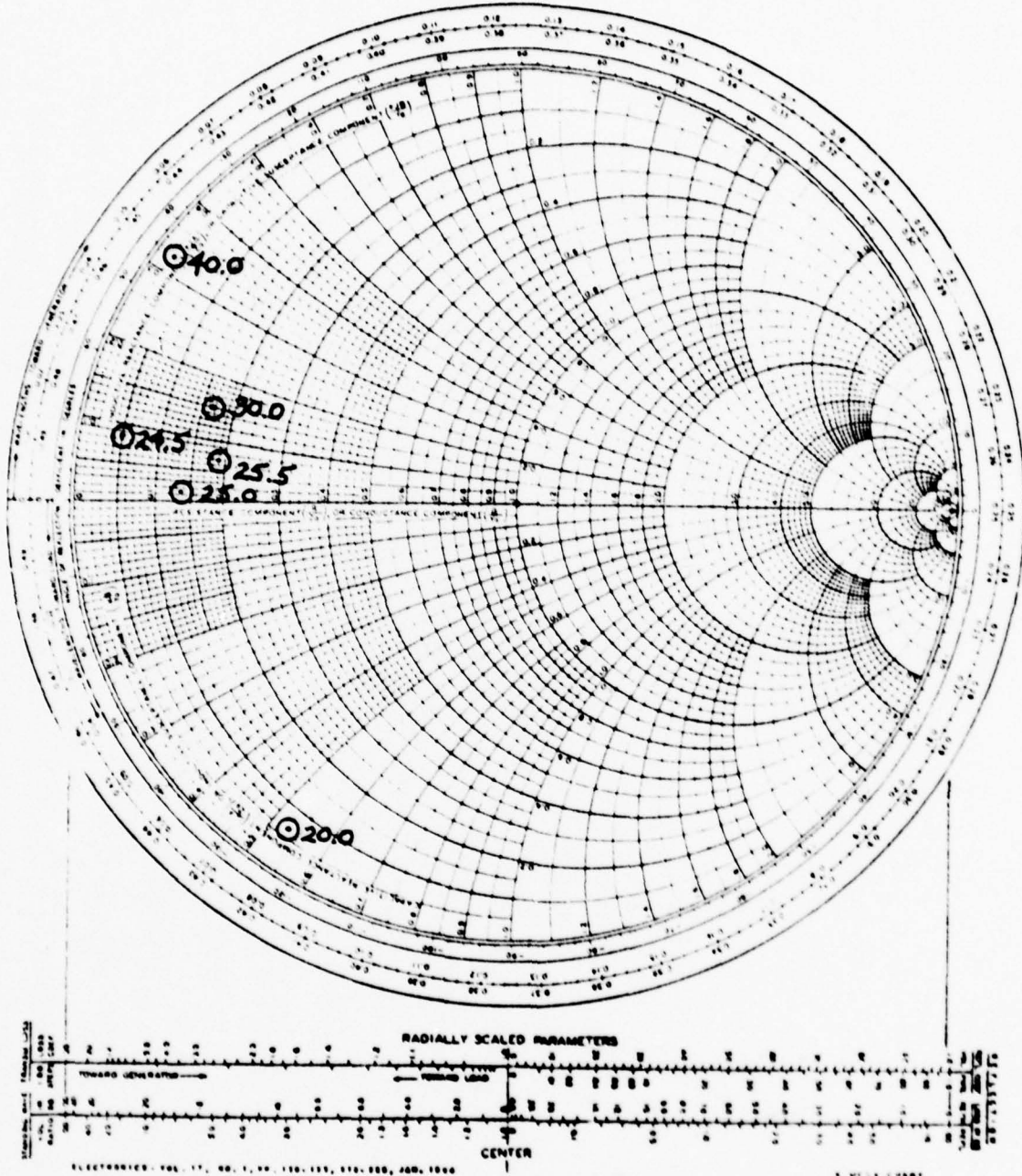

Figure 9  
 Test Results  
 6.75 Turn Helix (Data Points In MHz)

#### D. TOP LOADING MODIFICATION

As expected, the antenna showed a very large capacitive reactance at most frequencies. One of the easiest methods to improve both the real and reactive parts of radiation resistance is by top loading the antenna properly. [12] In effect, when a "top hat" is used, a large capacitance exists between the "top hat" and the ground plane which appears to be in parallel with the impedance of the antenna, thus, increasing the real part and reducing the capacitive part of radiation resistance.

The first modification was to place a .61 meter diameter sheet aluminum "top hat" (circular plate) on the improved design antenna (6.75 turn helix) and connect it to the top of the helix with copper tape. The size of the "top hat" was chosen so that there would be no edges overhanging the circumference of the helix. Although a larger top loading surface would, theoretically, have more effect, it seemed to be a reasonable trade-off to use the smaller disc to keep the antenna more compact.

The results of testing this configuration are presented in Table 4 and Figure 10 and 11. Considerably fewer data points were taken than with the unloaded antenna due to time and weather constraints and because a more detailed empirical analysis was felt to be unnecessary to verify the validity of top loading the helix.

TABLE 4

Test Results of 6.75 Turn  
Helix With .61 Meter "Top  
Hat" Loading

<u>Frequency (MHz)</u>	<u>Impedance (50<math>\Omega</math> System)</u>	<u>VSWR</u>
4.0	2.5 - j137.5	171.56
5.0	40.0 - j157.5	14.38
6.0	14.0 - j60.0	8.88
7.0	50.0 - j210.0	19.59
8.0	9.0 - j115.0	35.13
9.0	50.0 - j250.0	26.96
10.0	30.0 - j135.0	14.35
11.0	6.0 - j60.0	20.14
12.0	2.5 - j40.0	32.79
15.0	67.5 + j72.5	3.35
20.0	3.0 - j27.5	21.71
30.0	5.5 + j26.0	11.58

IMPEDANCE OR ADMITTANCE COORDINATES

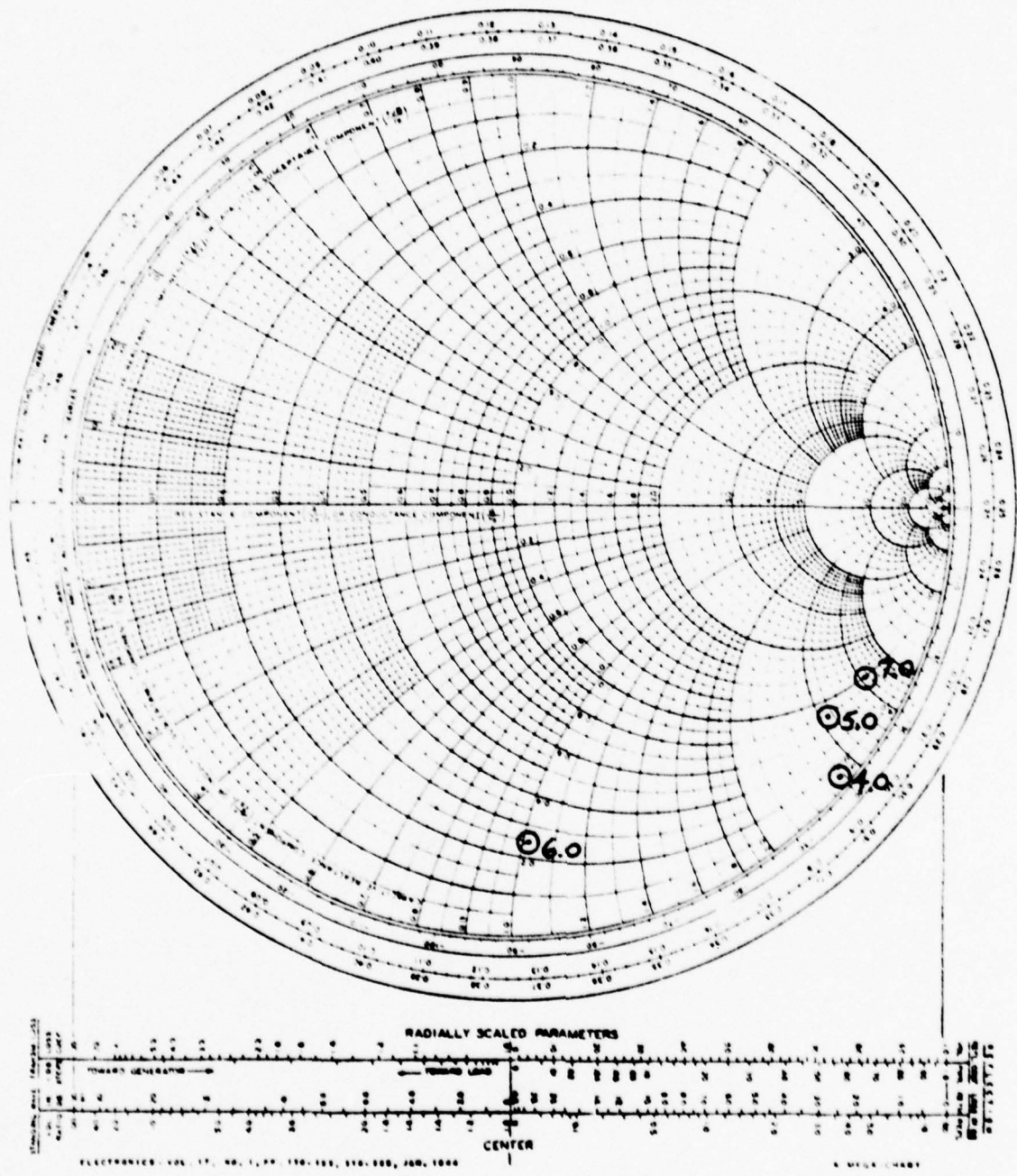

Figure 10  
 Test Results  
 6.75 Turn Helix With 6.1 Meter Top Hat

IMPEDANCE OR ADMITTANCE COORDINATES

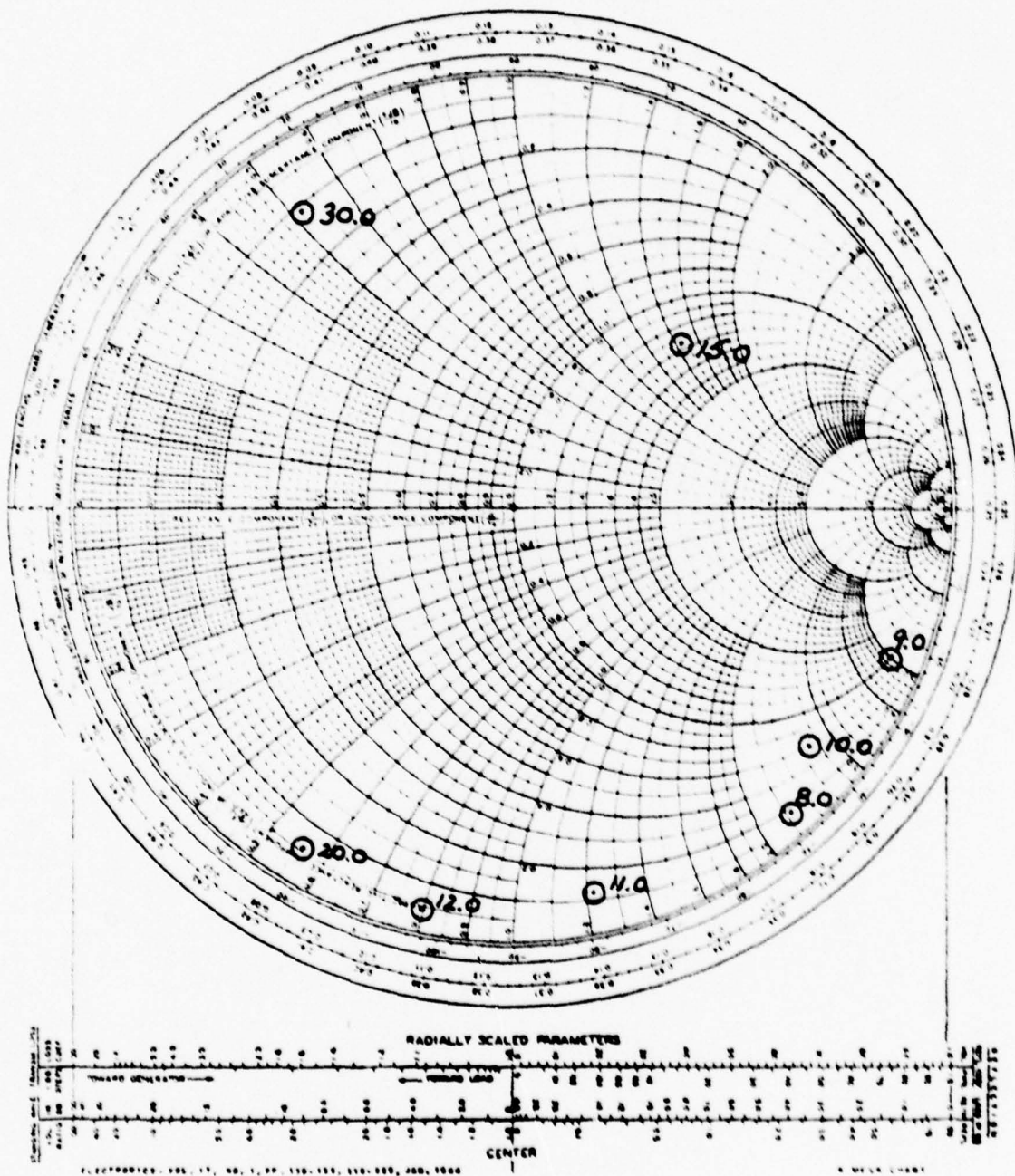

Figure 11  
 Test Results  
 6.75 Turn Helix With .61 Meter Top Hat

A second "top hat" of slightly larger diameter (.91 meters) than the helix (.7 meters) was also tested to observe the increase in the effect of the top loading. These results are shown in Table 5 and Figures 12 and 13.

TABLE 5

Test Results Of 6.75 Turn  
Helix With .91 Meter "Top  
Hat" Loading

<u>Frequency (MHz)</u>	<u>Impedance (50<math>\Omega</math> System)</u>	<u>VSWR</u>
4.0	9.0 - j135	46.26
5.0	30.0 - j200.0	28.90
6.0	180.0 + j300.0	14.09
7.0	40.0 - j250.0	63.17
8.0	60 - j210.0	41.93
9.0	110.0 - j160.0	22.84
10.0	29.0 - j130.0	86.54
11.0	26.0 - j70.0	96.44
12.0	5.0 - j50.0	505.39
14.0	5.0 - j6.5	512.53
16.0	1.0 - j87.5	521.63
18.0	32.0 + j44.0	78.01
20.0	2.5 - j24.5	1004.66
25.0	.5 + j15.5	4996.33
30.0	21.5 + j37.5	119.01

IMPEDANCE OR ADMITTANCE COORDINATES

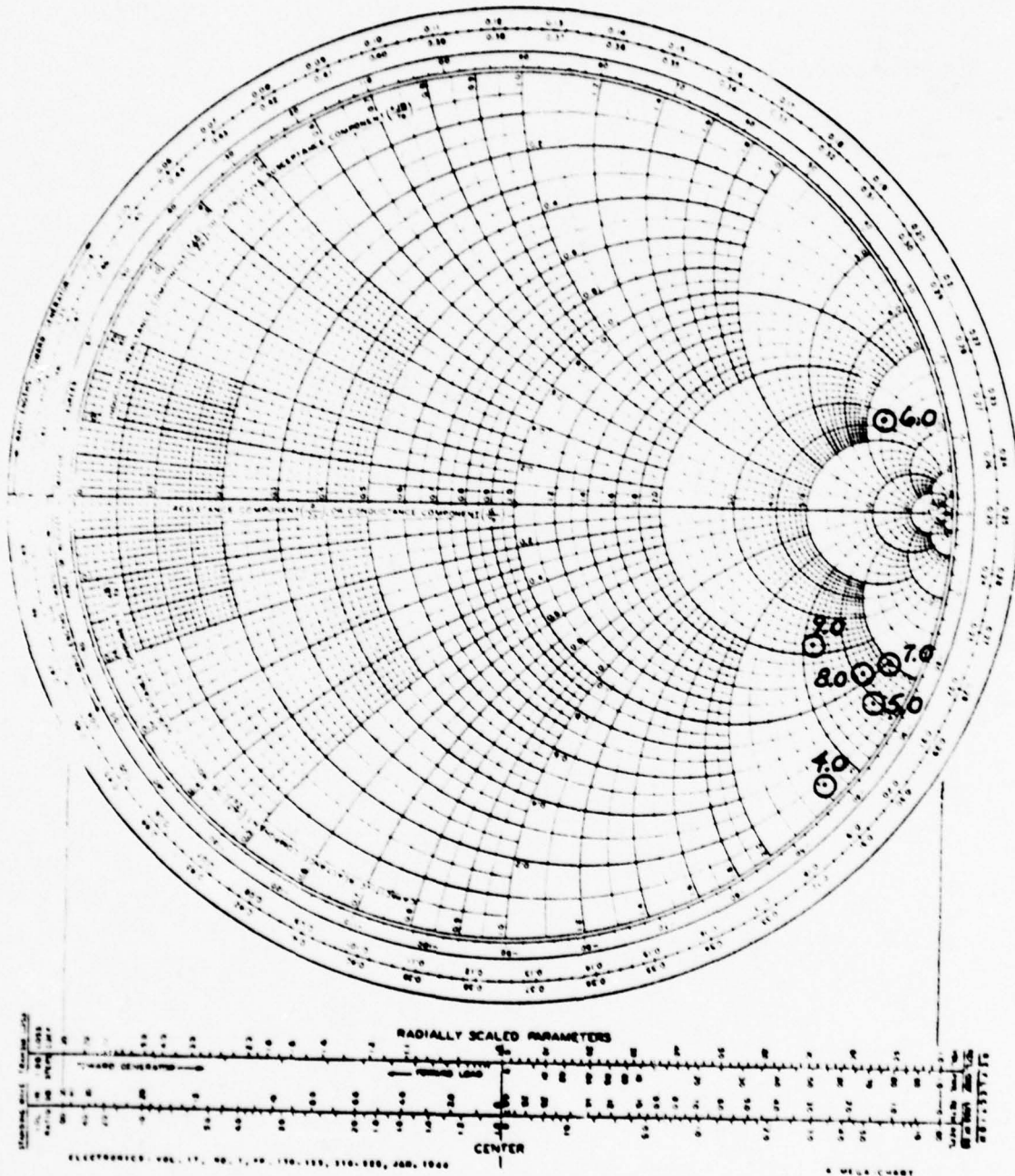

Figure 12  
Test Results  
6.75 Turn Helix With .91 Meter Top Hat

IMPEDANCE OR ADMITTANCE COORDINATES

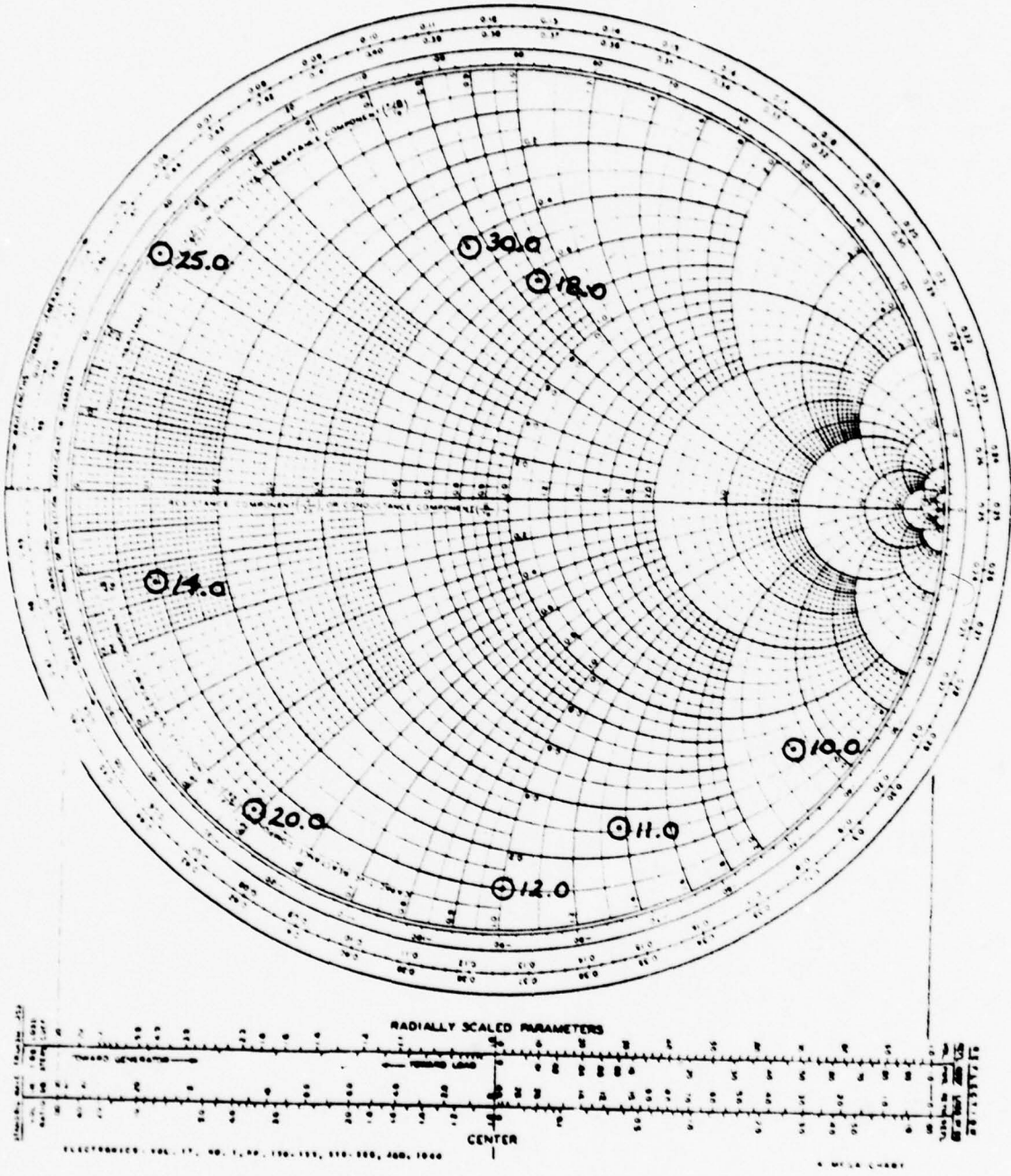

Figure 13  
 Test Results  
 6.75 Turn Helix With .91 Meter Top Hat

#### E. RETEST OF INITIAL DESIGN

The original 9.5 turn helical antenna was repaired with new sections of copper tape and reconfigured with the same type coaxial termination as the 6.75 turn improved design antenna. A limited retest of this antenna was conducted with the results as shown in Table 6 and Figure 14. This retest was made to verify the assumption that the original results were in error due to problems with the ground plane connector. The retest results seem to bear out that theory.

TABLE 6

## Results Of Retest Of 9.5 Turn Helix

<u>Frequency (MHz)</u>	<u>Impedance (50<math>\Omega</math> System)</u>	<u>VSWR</u>
6.0	150 - j300	13.89
8.0	1 - j87.5	204.64
10.0	12 - j57.5	9.81
12.0	5 - j75	32.60
14.0	13 - j70	11.56
16.0	2 - j21	29.41
20.0	2 - j23	30.29

IMPEDANCE OR ADMITTANCE COORDINATES

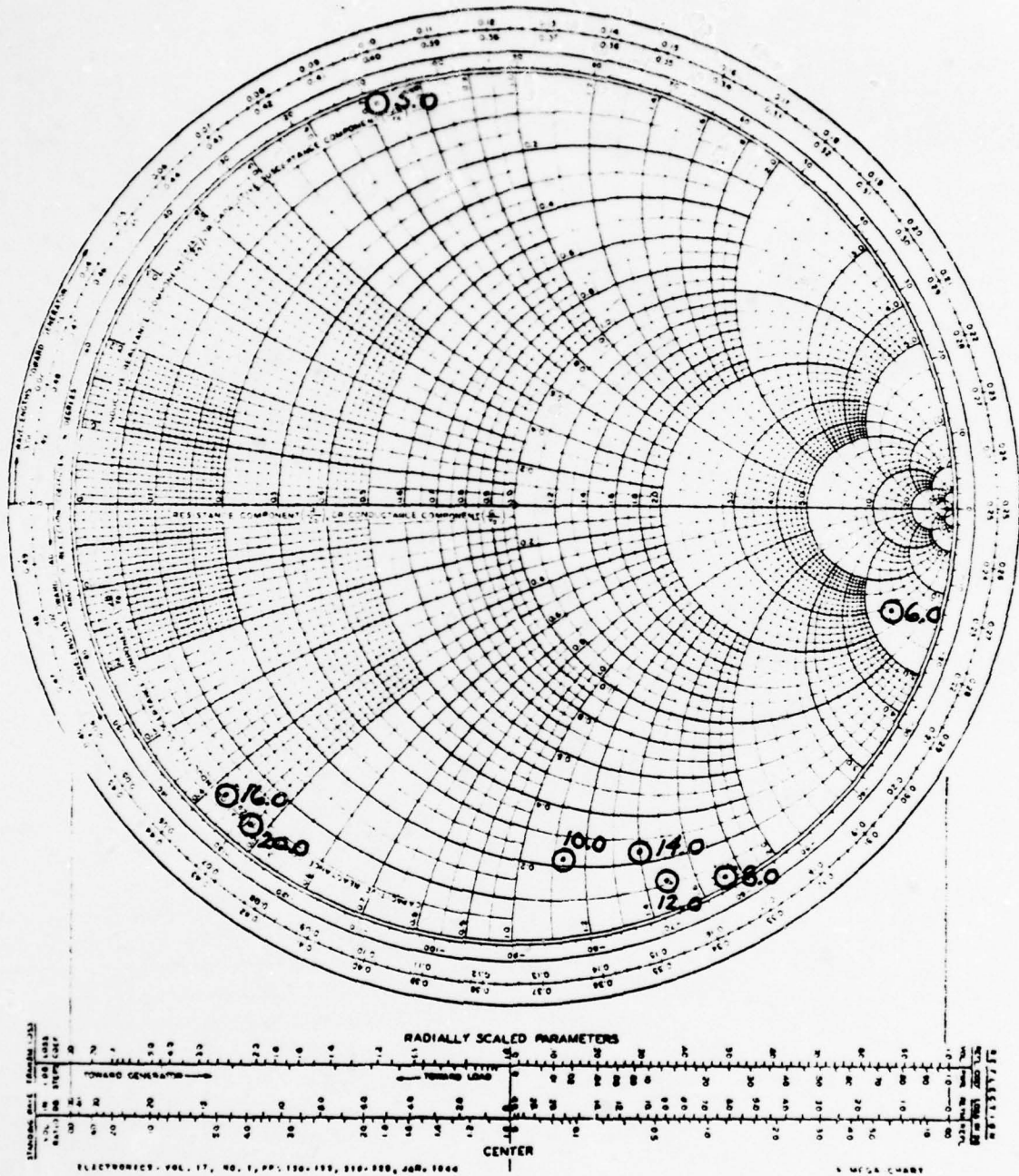

Figure 14  
Retest Of 9.5 Turn Helix

## F. ANALYSIS OF RESULTS

The test procedure used for measuring the complex impedance has several possibilities for inducing errors in the results. The most serious problems are caused by line length from signal generator to antenna, line losses and instrument accuracy, all factors over which the operator has little control. An understanding of these problems aids in the evaluation of the validity of the data. First of all, line length is compensated for by using the procedure in Appendix A, however, a problem arises whenever the length is a multiple of one-quarter wavelength at the test frequency. With a short circuit in place for calibration, when the line is near an odd multiple of one-quarter wavelength, the magnitude of the measured quantity  $B/A$  is nearly 2 and the phase angle is zero. Because of line losses, the observed magnitude of  $B/A$  never reaches 2 and the calibration reference point is largely a matter of judgement over a range from +10 degrees to -10 degrees of indicated phase angle. This ambiguity is compounded by the vernier adjustment provided on the phase meter. When the line length is near an even multiple of one-quarter wavelength, the magnitude of  $B/A$  is nearly zero and the vector voltmeter has difficulty in tracking the small voltage present. The size of the signal in channel B essentially becomes much smaller than the instrument accuracy relative to the signal in channel A. Additionally, it is nearly impossible to distinguish angles of

from 70 to 90 degrees on the Smith Chart due to the extremely short length of the vectors. Despite these limitations, it is felt that the data presented (with the exception of the initial antenna, as previously noted) should be within  $\pm 10\%$  of the actual values.

It is felt that the failure of the initial antenna design was due to the method of construction, primarily the type connector originally used, and to the lengthy process of determining a correct method for impedance measurement which resulted in excessive handling of and damage to the antenna. The retest bears out the supposition that the original testing is invalid.

The second antenna (unloaded 6.75 turn helix) showed resonant frequencies of about 6.26, 6.875, 14.6, 15.9 and 25 Megahertz. Near resonance, the real part of impedance was generally very low, as would be expected of a short antenna, with a correspondingly high voltage standing wave ratio (VSWR) representing a large mismatch between the antenna and a 50 ohm system. This small resistance is, however, still more than 15 times the predicted resistance of a short linear antenna. The equation:

$$R = \frac{h^2}{312} \quad (7)$$

where  $R$  = base radiation resistance (Ohms)

$h$  = height of antenna (Degrees)

predicts the theoretical radiation resistance for a thin vertical wire with a sinusoidal current distribution. [12]

Thus, a one meter tall linear antenna at 6.26 Megahertz has

has a theoretical radiation resistance of .18 ohms and the measured radiation resistance of the helix at that same frequency is 3 ohms. This represents a dramatic increase in theoretical antenna efficiency for a physically and electrically short antenna at these frequencies. The theoretical efficiency of the 6.75 turn helix is summarized in Table 7 as computed by the equation:

$$E = \frac{1}{1 + \frac{8.48 \times 10^{-10} f}{n b^3 a}}$$

where E = radiation efficiency  
 f = frequency (MHz)  
 n = number of turns  
 a = wire radius normalized to the wavelength  
 b = radius of helix normalized to wavelength

From 11.5 to 13 Megahertz, the impedance of the antenna remains almost constant. This can be explained in the following manner. When operating in the normal radiation mode, the current distribution on the helix is predominately a traveling wave identical to that occurring in a traveling wave tube. This is known as the  $T_0$  mode of transmission. [9] Assuming a velocity of wave propagation along the helix of .85 times the velocity of light in free space, the length of the antenna conductor is nearly one-half wavelength in the range from 11.5 to 13 Megahertz. This results in a standing wave being formed on the antenna and it then becomes

TABLE 7

Theoretical Efficiency Of 6.75  
Turn Helical Antenna .7 Meters In Diameter

<u>Frequency (MHz)</u>	<u>Efficiency (%)</u>
4	6.4
5	13.0
6	22.0
7	32.7
8	43.7
9	53.9
10	62.9
11	70.3
12	76.2
13	80.9
14	84.6
15	87.5
16	89.8
17	91.6
18	93.0
19	94.1
20	95.0

the major component of current distribution on the helix causing the same magnitude and phase of the corresponding voltage waveforms to be seen at the terminals of the antenna over this small frequency range. Confirmation of this hypothesis is given by an apparent occurrence of the same effect in the vicinity of 25 Megahertz where the helix approaches one wavelength in total length. This effect will disappear at higher frequencies as the helix transitions from the normal to the axial mode. When operating in the axial mode region, the radiation resistance remains fairly constant due to a different transmission mode dominating the current distribution. [9]

The addition of top loading appears to follow the theory closely, reducing the reactive component of radiation resistance while not changing the effective length, and thus the resonant frequencies, appreciably. As expected, the larger "top hat" had a more noticeable effect, especially in the upper high frequency region from 9 to 30 Megahertz.

## G. CONCLUSIONS AND RECOMMENDATIONS

Although the radiation resistance obtained by the method of this design is generally very low, the results for the loaded antenna are encouraging, particularly above 9 Megahertz. The theoretical efficiency of the antenna is a more than adequate match for the conventional 35 foot whip antenna above 8 Megahertz and, as suggested by Stevenson [14], the directive gain which can be obtained from the loaded helix more than offsets the losses inherent in the networks needed to match these antennas to a  $50\Omega$  system.

The loaded antenna results suggest that a much too broad tuning range was attempted in this design. The high frequency spectrum is probably best covered by two or three different helicies, each covering slightly more than one octave (2 - 6, 6 - 18, 18 - 32 MHz) for an individual tuning range of 3 to 1 or less.

The next step in this design study would be to further refine the design in the frequency bands above 9 Megahertz and then continue to work toward the lower frequencies. The helix can be reduced in diameter by one-half and a round conductor of diameter one-half the width of the tape can be substituted with the theoretical radiation efficiency remaining at 75 percent of the values in Table 7. This reduction in efficiency still leaves the values at a high level above 9 Megahertz. The resulting antenna would be one

meter in height and .35 meters in diameter. The conductor used for the windings would be 127 millimeter diameter copper tubing. The turn spacing should remain 4 times the conductor diameter to minimize the proximity effect and a .7 meter diameter "top hat" employed to load the antenna. This combination should result in a antenna with a larger real and smaller reactive component of input impedance. The first resonant frequency of this antenna would be around 7 Megahertz.

An additional design change would be to wind a second identical conductor mid-way between the existing turns and connect them at the top and the bottom to excite the antenna as a folded dipole. This should double the real part of radiation resistance while proximity losses would remain small as the center to center conductor spacing would still be twice the diameter of the conductor. The work of Vennum [15] and Smith [13] have shown that any attempt to fold the antenna more than once, causing the conductor spacing to become too small, results in the proximity losses becoming very large. For this reason, only two conductors should be used in this method of raising impedance. This modification should result in a radiation resistance of about 15 ohms.

Tuning of the antenna can be accomplished fairly easily using an inductance in series with the antenna. This coil can be placed either in the antenna feed line or in a line connected from the center of the "top hat" to the ground

plane. Both of these methods were demonstrated by Rockway [11] with the center leg tuning being considered the better of the two arrangements. The addition of the length of conductor from the top to the ground plane will most likely affect both the impedance and the resonant frequencies.

The further development of better high frequency antenna systems is of great importance to the Department of Defense to aid in more effective utilization of shrinking communications assets. The normal mode helix is a very promising device which requires further research on both the antenna itself and on the matching networks necessary for its employment. Of particular significance for defense communications applications is the degree of immunity to damage from weather and blast effects provided by the short, fat profile of the helix, as configured in this paper. Additionally, the relatively narrow bandwidth of the helix provides good off-frequency isolation which reduces the effects of atmospheric noise somewhat. The advantage of circular polarization, as previously discussed, is also a significant property of the normal mode helix.

The test procedures used in this paper have severe limitations. The inaccuracies inherent have already been discussed, but another problem also needs to be addressed. With the equipment available, each discrete measurement takes an average of 20 minutes for calibration and then data taking. Because of this, measuring the resonant frequencies is a lengthy and imprecise process. This point by point procedure

also makes it difficult and time consuming to observe the effects of design modifications. The procurement and use of a swept frequency network analyzer (such as the Hewlett-Packard HP 8754A) would greatly facilitate further design analysis.

## APPENDIX A

### Technique for measuring complex impedance of an antenna in the frequency range 1 to 100 Megahertz using the Hewlett-Packard HP 8504A Vector Voltmeter

The procedure described by Hewlett-Packard in their Application Note 77-3 can be used once the implications of the note are understood. The set-up uses a symmetrical power splitter, two 20 dB pads for isolation, two probe tees for the vector voltmeter connections and a 50 ohm termination for one channel (see Figure A-1).

Since channel A is terminated in the system characteristic impedance ( $50\Omega$ ), there is no reflection from the termination and channel A reads only the incident signal ( $E_i$ ). Channel B will read the magnitude of the vector sum of the incident signal and any reflected signal from the terminating device. The ratio of B to A is then:

$$\frac{B}{A} = \frac{E_i + E_r}{E_i} = 1 + \rho = |1 + \rho| \angle \theta_1 + \rho$$

The phase angle between the two channels is read from the phase meter.

This magnitude and angle can be plotted on a Smith Chart, as shown in Figure A-2. It must be noted, however, that the magnitude  $1 + \rho$  cannot simply be measured from the left side of the Smith Chart to the point 1.5. The correct procedure is to measure off the distance 1 from the left of the chart, then begin again at the left and measure  $\rho$  and add this distance to 1. This makes the total distance across the chart

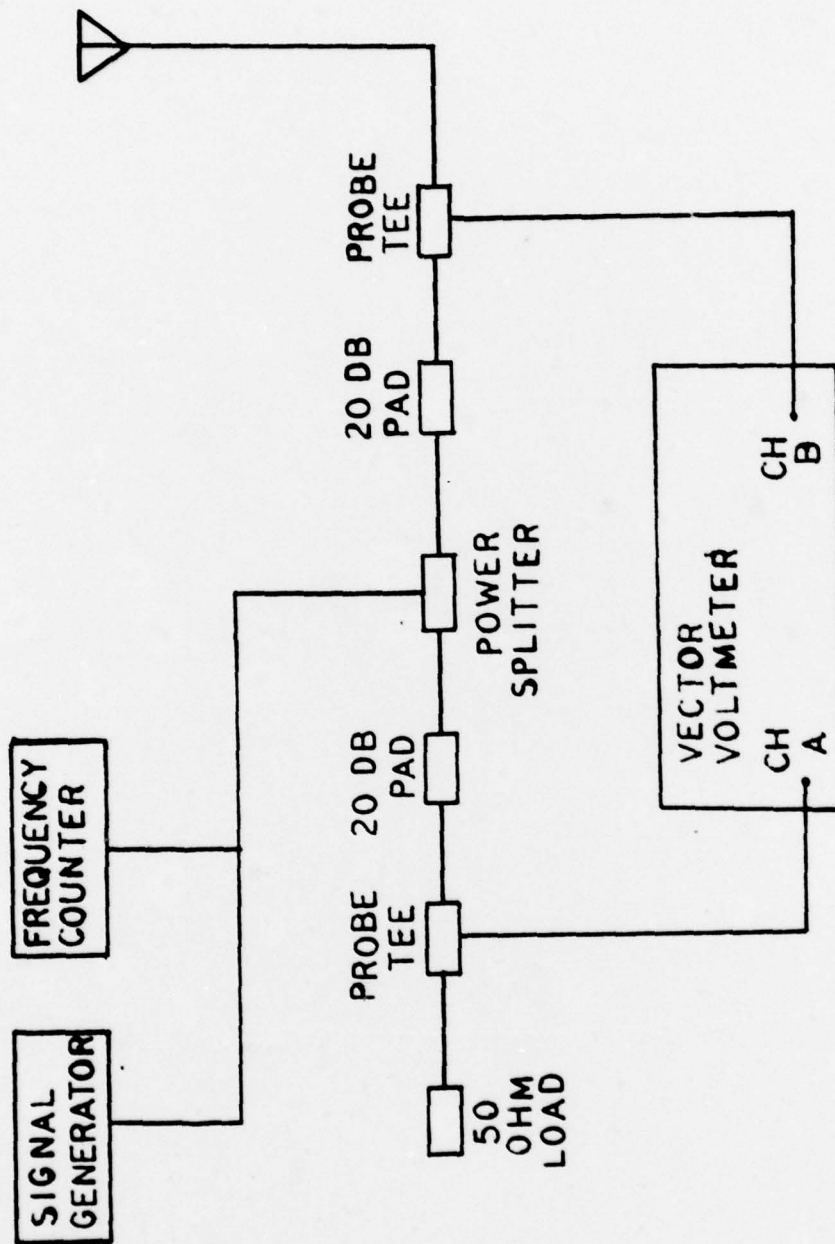

Figure A-1  
Diagram Of Test Equipment Set-UP

IMPEDANCE OR ADMITTANCE COORDINATES

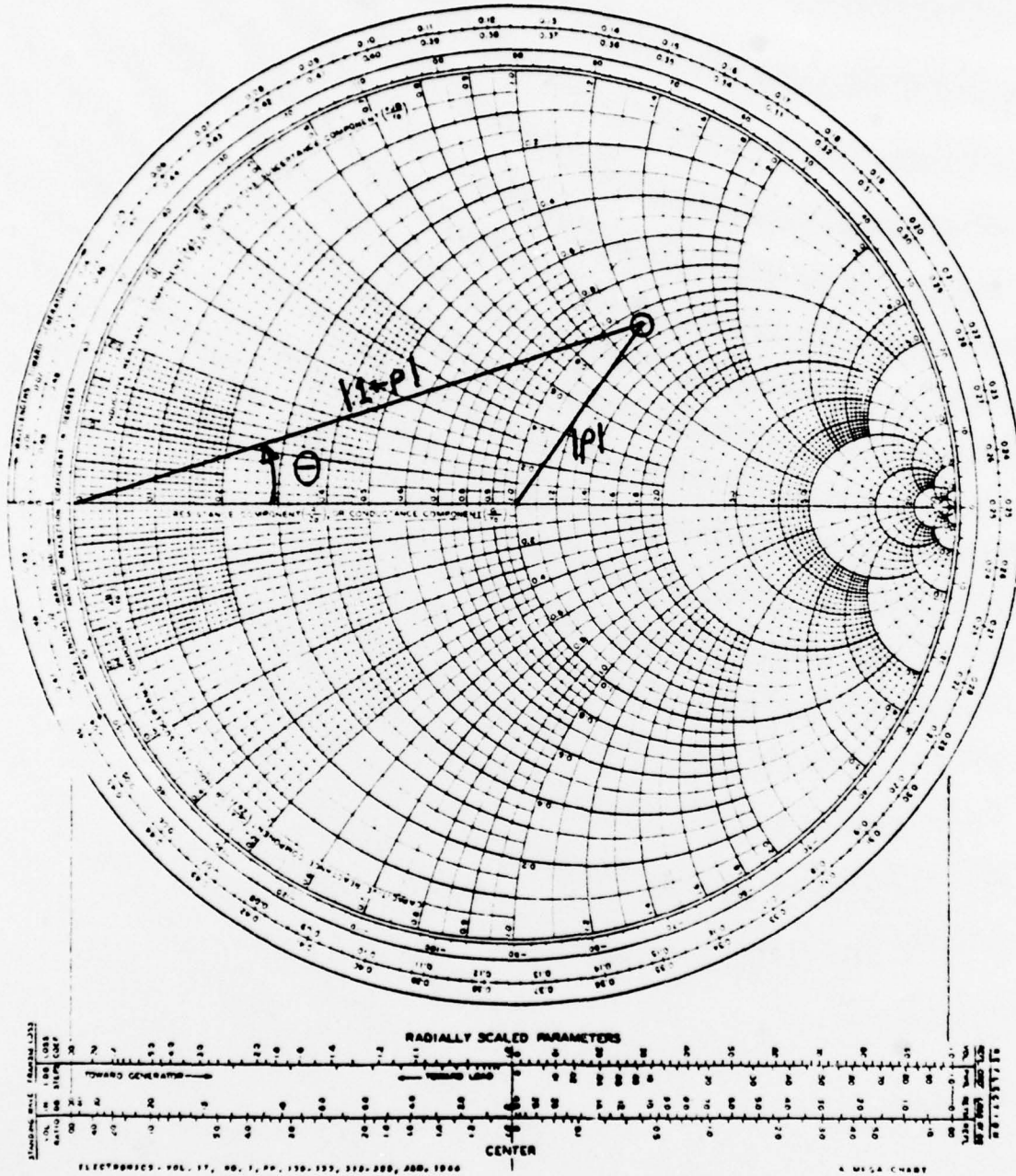

Figure A-2

equal to 2 instead of infinity. This can be most clearly seen when channel B is terminated in a short circuit at the end of a transmission line which is an odd multiple of one-quarter wavelengths long. The magnitude of B/A is nearly 2 and the angle is 0 degrees. Since the short must lie on the circumference of the Smith Chart ( $R=0$ ), the total distance across the chart must be 2.

This system must be calibrated at each frequency to compensate for the electrical length of the transmission line to the antenna. This calibration is accomplished by terminating the line with a short circuit and plotting the magnitude of B/A and the angle,  $\theta$ , as read from the vector voltmeter. It will be found that these readings do not always lie exactly on the circumference of the chart due primarily to line losses and instrument inaccuracies. The method used to resolve any ambiguity was to measure the magnitude of B/A and swing this distance, in the direction of the indicated angle (positive angles counter-clockwise; negative angles clockwise), from the left side of the Smith Chart until it intersects the circumference. The angle which is measured off the chart will usually be within a few degrees of that indicated on the vector voltmeter. Using the phase zero control, the true angle can be set on the vector voltmeter.

Once the short has been plotted, the amount of offset is easily determined by noting the angle between the chart horizontal axis and a line drawn from the center of the chart to the point on the circumference where the short was plotted. Any measurements of a device at this same frequency

must be rotated the same amount as the offset in the opposite direction to compensate for line length.

An example is given in Figure A-3. With a short in place,  $B/A$  is read from the vector voltmeter as  $1.08\angle 55^\circ$  and is plotted as line  $OA$ . The angle  $70^\circ$  is the amount which the unknown will have to be rotated counter-clockwise. The unknown is measured to be  $1.10\angle -17^\circ$  and is plotted as line  $OB$ . Point  $B$  is then rotated  $70^\circ$  counter-clockwise to compensate for line length and the normalized impedance is read from the chart as  $2.2 + j0.0$ . This corresponds to an input impedance, referenced to a 50 ohm system, of 110 ohms.

IMPEDANCE OR ADMITTANCE COORDINATES

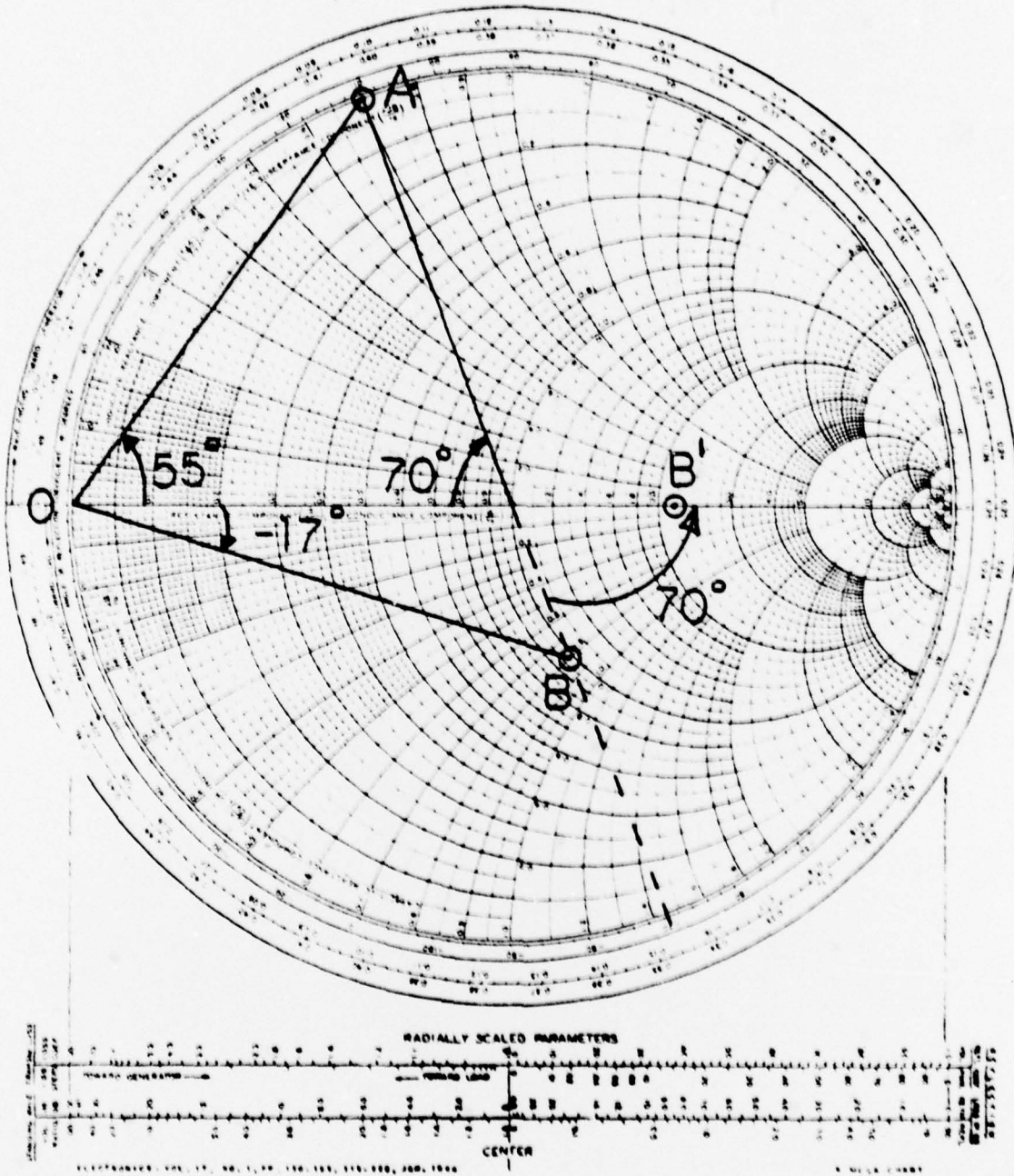

Figure A-3  
Example of Impedance Measurement Procedure

## BIBLIOGRAPHY

1. Appleton, Edward V., "A Simple Method of Demonstrating the Circular Polarization of Ionospherically Reflected Radio Waves", Nature, v. 151. p. 250, February 17, 1943.
2. Bohley, P., C. H. Walter and R. Caldecott, Development of the Multi-turn Loop Antenna at HF for Shipboard Applications, Ohio State University Electro Science Laboratory Report 351801, Contract N00024-73-C-1023, Naval Ship Systems Command, 1973.
3. Brown, R. G., Sharpe, R. A., Hughes, W. L., and Post, R. E., Lines, Waves and Antennas, p. 435-438, The Ronald Press, 1973.
4. Hewlett-Packard Company, Application Note 77-3.
5. Jordan, E. C. and Balmain, K. G., Electromagnetic Waves and Radiating Systems, p. 535-539, Prentice Hall, Inc., 1968.
6. Kandoian, A. G. and Sichak, W., Wide Frequency Range Tuned Helical Antennas and Circuits, Federal Telecommunications Laboratories, Inc., 1953.
7. Kraus, J. D., Antennas, p. 173-214, McGraw-Hill Book Company, Inc., 1950.
8. Li, T. and Beam, R. E., "Helical Folded Dipoles and Monopoles", Proceedings of the National Electronics Council, v. XIII, p. 89-105, March 1958.
9. Marsh, J. A., "Current Distributions on Helical Antennas", Proceedings of the I.R.E., v. 39, p. 668-675, June 1951.
10. Mitra, S. N., "Fading of Short Wireless Waves Due to the Interference Between the Magneto - Ionic Components", Industrial Journal of Physics, v. 24, p. 197-206, 1950.
11. Naval Electronics Laboratory Center Technical Note 3170, HF Normal Mode, Tunable Helical Antenna Development, by J. W. Rockway, J. C. Logan, and W. M. Chase, 26 May 1976.
12. Smith, Carl E. and Johnson, E. M., "Performance of Short Antennas", Proceedings of the I.R.E., v. 35, p. 1026-1038, October 1947.

13. Smith, Glenn, The Proximity Effect in Systems of Parallel Conductors and Electrically Small Multiturn Loop Antennas, Harvard University Division of Engineering and Applied Physics, Technical Report No. 624, December, 1971.
14. Stephenson, D. T. and Mayes, P. E., "Normal Mode Helices as Moderately Superdirective Antennas", IEEE Transactions on Antennas and Propagation, AP 14 No. 1, p. 108-110, January, 1966.
15. Vennum, Michael D., An Investigation of the Possible Uses of the Normal Mode Helical Antenna in the Tactical Army, M.S.E.E. Thesis, Naval Postgraduate School, Monterey, California, March 1978.
16. Wheeler, H. A., "A Helical Antenna for Circular Polarization", Proceedings of the I.R.E., v. 35, p. 1484-1488, December, 1947.

INITIAL DISTRIBUTION LIST

	No. of Copies
1. Library, Code 0142 Naval Postgraduate School Monterey, California 93940	2
2. Department Chairman, Code 62 Department of Electrical Engineering Naval Postgraduate School Monterey, California 93940	1
3. Assoc. Prof. O. M. Baycura, (Code 62By) Department of Electrical Engineering Naval Postgraduate School Monterey, California 93940	9
4. Commander Naval Telecommunications Command Naval Telecommunications Command Headquarters 4401 Massachusetts Avenue, N.W. Washington, D.C. 20390	1
5. Director Naval Communications Division(OP-941) Washington, D.C. 20350	1
6. Lieutenant Robert E. Maskell 3109 Gibbons Avenue Baltimore, Maryland 21214	4
7. Captain Michael Vennum, USA U. S. Army Communications Electronic Engineering Installation Agency (W3BNAA-A) ATTN: CCC-PRSO-F Fort Huachuca, Arizona 85613	1
8. Defense Documentation Center Cameron Station Alexandria, Virginia 22314	2