

AD-A070 163

ARMY ELECTRONICS RESEARCH AND DEVELOPMENT COMMAND WS--ETC F/6 17/1
LONG-RANGE ARTILLERY SOUND RANGING: 'PASS' 6R-8 SOUND RANGING D--ETC(U)
MAR 79 A J BLANCO
ERADCOM/ASL-TR-0027

UNCLASSIFIED

NL

| OF |
AD
A070163



END
DATE
FILMED
7-79
DDC

LEVEL

12

ASL-TR-0027

AD
Reports Control Symbol
OSD - 1366

AD A070163

**LONG-RANGE ARTILLERY SOUND RANGING:
"PASS" GR-8 SOUND RANGING DATA**

MARCH 1979

By

ABEL J. BLANCO

DDC
RECEIVED
JUN 19 1979
C

DDC FILE COPY

Approved for public release; distribution unlimited



US Army Electronics Research and Development Command
Atmospheric Sciences Laboratory

White Sands Missile Range, NM 88002

79 06 18 048

NOTICES

Disclaimers

The findings in this report are not to be construed as an official Department of the Army position, unless so designated by other authorized documents.

The citation of trade names and names of manufacturers in this report is not to be construed as official Government indorsement or approval of commercial products or services referenced herein.

Disposition

Destroy this report when it is no longer needed. Do not return it to the originator.

⑨ Research and development technical rept.,

SECURITY CLASSIFICATION OF THIS PAGE (When Data Entered)

REPORT DOCUMENTATION PAGE		READ INSTRUCTIONS BEFORE COMPLETING FORM
1. REPORT NUMBER ERADCOM ASL-TR-0027	2. GOVT ACCESSION NO.	3. RECIPIENT'S CATALOG NUMBER
4. TITLE (and Subtitle) LONG-RANGE ARTILLERY SOUND RANGING: "PASS" GR-8 SOUND RANGING DATA	5. TYPE OF REPORT & PERIOD COVERED R&D Technical Report	
7. AUTHOR Abel J. Blanco	6. PERFORMING ORG. REPORT NUMBER	
9. PERFORMING ORGANIZATION NAME AND ADDRESS Atmospheric Sciences Laboratory White Sands Missile Range, New Mexico 88002	8. CONTRACT OR GRANT NUMBER(s)	
11. CONTROLLING OFFICE NAME AND ADDRESS US Army Electronics Research and Development Command Adelphi, MD 20783	10. PROGRAM ELEMENT, PROJECT, TASK AREA & WORK UNIT NUMBERS DA Task No. 1L162111AH71/26	
14. MONITORING AGENCY NAME & ADDRESS (if different from Controlling Office)	12. REPORT DATE Mar 1979	13. NUMBER OF PAGES 124 p.
	15. SECURITY CLASS. (of this report) UNCLASSIFIED	
16. DISTRIBUTION STATEMENT (of this Report) Approved for public release; distribution unlimited.		
17. DISTRIBUTION STATEMENT (of the abstract entered in Block 20, if different from Report)		
18. SUPPLEMENTARY NOTES		
19. KEY WORDS (Continue on reverse side if necessary and identify by block number) Sound ranging Acoustics Met data "PASS" sound ranging data ground recorder		
20. ABSTRACT (Continue on reverse side if necessary and identify by block number) The GR-8 records from the "PASS" field experiment were reexamined to develop a research data base for use in the evaluation of proposed sound ranging meteorological messages and solution algorithms. Since all surveyed sound sources were located at ranges greater than 10 km, the recorded sound signals are weak due to the atmospheric attenuation. Under these conditions the record reader required automatic aids in selecting the arrival times. Over 500 GR-8 data tapes were semiautomatically read and the automated processes that allowed editing in the selection procedure are defined. Using the current artillery		

DD FORM 1 JAN 73 1473 EDITION OF 1 NOV 65 IS OBSOLETE

SECURITY CLASSIFICATION OF THIS PAGE (When Data Entered)

410663

Done

over

20. ABSTRACT (cont)

meteorological correction and these automatic aids, this analysis suggests a significant improvement over the manual process of selecting the arrival times. With these aids the record reader was able to provide more timely arrival time data that permitted sound source location with miss-distances less than 1.5 percent of the over 10 km range targets.

A

0/0

SUMMARY

The first step for rereading all the GR-8 record tapes was to use the manually selected arrival times to derive the direction rays and automatically plot their intersections. Using this as an aid the record reader could identify which microphone record needed verification. In the case of unknown target location, this type of editing was limited to checking only the rays that deviated significantly from the well-defined intersection cluster. It should be pointed out that for field data a single point intersection does not necessarily provide the best estimate of source location. Using the centroid method for determining the final location, the spread of the polygon of error (defined by the ten intersections of the five rays) may be as high as an equivalent 400-m radius.

Another aid was added to the automatic plot, which required an initial estimate of the sound source direction. If an accurate initial guess of the direction of the sound source were not available, the problem could be solved by using the manual method, and the computed direction of the source location would then be used. The available meteorological message was also used in computing the theoretical arrival time. The second time the record reader examined the GR-8 tape, the computed arrival time for each microphone was displayed. The reader looked at that particular point and then adjusted to keep the same selection criteria (break, valley, crossover, or peak) for all six microphone traces. The appendix contains the selected arrival times, and the plots of the direction rays confirm the spread for each fix contained in the research data base.

With the use of newer techniques, including editing procedures to more accurately select arrival times and use of accurate meteorological data, longer range sound ranging targets were located within 1.5 percent of the target range.

Accession For	
NTIS G&I	<input checked="" type="checkbox"/>
DDC TAB	<input type="checkbox"/>
Unannounced	<input type="checkbox"/>
Justification	
By _____	
Distribution/	
Availability Codes	
Dist	Avail and/or special
<i>A</i>	

CONTENTS

	<u>Page</u>
SUMMARY	1
INTRODUCTION	3
EXPERIMENTAL APPROACH	3
RECORD READING	4
SOUND RANGING METHOD	9
EXPERIMENTAL DATA EDITING	9
EXPERIMENTAL RESULTS	14
CONCLUSIONS	14
REFERENCES	19
APPENDIX	20

INTRODUCTION

State of the art has enhanced the artillery capability so that today tactical artillery support is effectively provided at much longer ranges. In response to this new capability, a current target acquisition approach is reexamined with the emphasis on locating enemy artillery targets at ranges greater than 10 km. Since World War I, artillery sound ranging has yielded more confirmed target locations than all other methods combined. This method is a passive technique and requires an array of microphones that provide the artillery record reader with data identifying the sound arrival time at each microphone. It is fundamentally a direction finding technique which uses the sound arrival time data to derive direction rays. The artilleryman then uses the intersection of the different rays to estimate a sound source location.

Between October and December 1974, a ground recorder (GR-8) sound ranging set with six microphones was operated during the Atmospheric Sciences Laboratory meteorological comparisons test (Project PASS).¹ During this experiment the sound wave from explosions at surveyed locations were monitored by using a surveyed linear-array of hot-wire-type microphones (T-23). A basic review of the manual record reading procedure is included in the report for providing general information. The data base for the GR-8 sound arrival times is also included in the report. Some results concerning the interactions between the best available meteorological conditions,² the microphone record readings, and the centroid method employed for determining the sound source locations are presented.

Automated assistance in record reading is emphasized, with a significant improvement demonstrated on the solution of the long-range artillery sound ranging problem. Data collected during the experiment and read immediately thereafter were used to compute the sound source location. These results were then compared to those derived by employing automated aides in record reading of sound arrival times.

EXPERIMENTAL APPROACH

To demonstrate the accuracy of sound ranging at ranges greater than 10 km, a comprehensive experiment was performed to acquire the required sound ranging data. Data from surveyed microphones were used to calculate the position of the surveyed sound sources.

¹K. M. Barnett, 1976, "A Description of the Artillery Meteorological Comparisons at White Sands Missile Range, October 1974-December 1974 ("PASS" - Prototype Artillery [Meteorological] Subsystem)," ECOM-5589, Atmospheric Sciences Laboratory, White Sands Missile Range, NM

²A. J. Blanco, 1978, "Long-Range Artillery Sound Ranging: "PASS" Meteorological Application," ASL-TR-0014, Atmospheric Sciences Laboratory, White Sands Missile Range, NM

The GR-8 Sound Ranging System³ as used on this test consisted of six (T-23) "hot wire" microphones in a four-second linear array. The remote timer unit (PE 244) and recorder (BC 1337) were powered by a 12-volt storage battery. This battery was constantly charged by a dc power source operating on normal 110-volt power. The microphones responded to atmospheric pressure changes created by 5-pound C4 explosive charges, 8-inch howitzer gun blasts, and shell bursts. Figure 1 illustrates the relative position of the sound sources with respect to the linear array of microphones, and table 1 lists the surveyed locations.

The selection of the arrival time for these air pressure changes at each microphone is used to determine the surveyed location of the source of these pressure changes. A considerable effort was made to immediately analyze the strip chart records. The time of arrival of the sound waves at each microphone was selected and entered on coding forms for later automated computations for locating the source location. All sound ranging equipment was supplied by the Target Acquisition Branch of Counter Fire Department, US Army Field Artillery School (USAFAS) at Fort Sill, Oklahoma. School personnel supervised the installation, maintenance, operation, and original data reduction of the GR-8 equipment throughout the comparisons at White Sands Missile Range (WSMR), New Mexico.

RECORD READING

After the equipment is checked out for operation, the attenuators located within the GR-8 recorder must be balanced. These attenuators are numbered to correspond to the microphone output they control, and each is individually adjusted. Currently there is no doctrine for an ideal setting. Only experience gained through operation under the current local conditions can determine the ideal setting. The adjustment of the attenuators determines the difference between recording usable and non-usable records. The amplitude of the microphone signals is translated into a written record on the recording paper which contains time markings as series of dots (1/10 second and 1/100 second markers) along one edge of the paper. The record can be read to 10 milliseconds and interpolated to 1 millisecond. According to Field Manual FM 6-122, the errors inherent in visual interpolation will yield arrival times accurate to within 0.003 second.⁴

³TM 11-2568, 1945, "Sound Ranging Set GR-8," War Department Technical Manual, Headquarters, Department of the Army, Washington, D.C.

⁴FM 6-122, 1964, "Artillery Sound Ranging and Flash Ranging," Department of the Army Field Manual, Headquarters, Department of the Army, Washington, D.C.

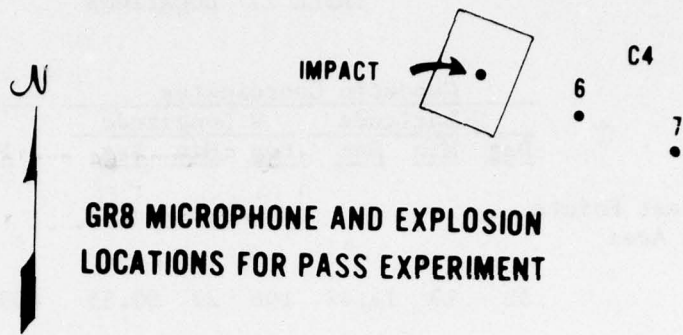

GR8 MICROPHONE AND EXPLOSION LOCATIONS FOR PASS EXPERIMENT

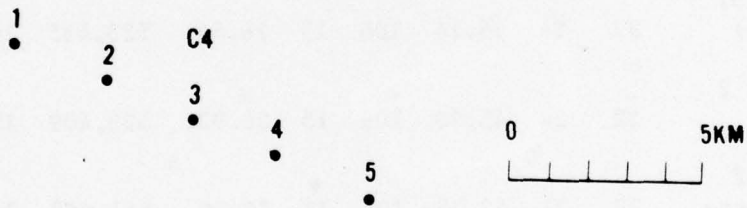
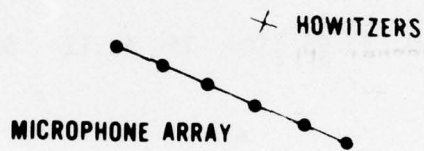

Figure 1. The relative position of the sound sources with respect to the linear array of microphones.

TABLE 1. LOCATIONS

	Geodetic Coordinates						WSIM Coordinates		
	N Latitude			W Longitude			X	Y	Z
	<u>Deg</u>	<u>Min</u>	<u>Sec</u>	<u>Deg</u>	<u>Min</u>	<u>Sec</u>	<u>Ft</u>	<u>Ft</u>	<u>Ft</u>
C4 Blast Points South Area									
1	32	19	11.42	106	22	00.55	489,655	155,724	4,016
2	32	18	36.90	106	20	25.66	497,798	152,235	4,004
3	32	18	02.37	106	18	50.79	505,941	148,745	4,059
4	32	17	27.83	106	17	15.94	514,083	145,258	4,072
5	32	16	53.25	106	15	41.11	522,226	141,768	4,078
C4 Blast Points North Area									
6	32	31	07.71	106	10	20.74	549,600	228,147	4,026
7	32	30	33.06	106	08	45.73	557,742	224,658	4,086
Howitzer 1 (12Z480) (center of trunnion)									
	32	24	45.14	106	15	26.64	523,435	189,456	4,041
Howitzer 2 (12HM73)									
	32	24	45.26	106	15	26.93	523,409	189,468	4,041
Center of Impact Area									
	32	31	42.35	106	11	55.79	541,457	231,636	4,034
T-23 microphones (left to right)									
1	32	24	27.83	106	17	56.54	510,584	187,700	4,040
2	32	24	10.49	106	17	09.04	514,657	185,949	4,049
3	32	23	53.30	106	16	21.56	518,730	184,214	4,046
4	32	23	35.97	106	15	34.10	522,800	182,465	4,046
5	32	23	18.70	106	14	46.67	526,868	180,723	4,044
6	32	23	01.42	106	13	59.21	530.940	178,980	4,061

The point at which the trace first departs from its straight line path (or zero line) is the initial break. The low and high points on the periodic trace are called valleys and peaks, respectively. A curve representing the variation of pressure with time at a given point on a path of the sound wave is shown in figure 2. The total elapsed time from the initial break through one cycle of oscillation is the period of the sound wave.

During this field experiment a four-second displacement between adjacent microphones was selected to sound range on source targets at ranges greater than 10 km. This experiment did not duplicate collection of sound ranging data but enhanced the Army sound ranging data base to contain longer ranges at various flank angles. The linear microphone array was selected to establish an expected pattern of the arrival of the sound wave at the various microphones of the sound ranging base. For example, the C4 explosion on location 1 gave the typical pattern illustrated on figure 3. The microphones are labeled from right to left as one faces the direction of observation for sound ranging. The current doctrine is to sound range in a forward zone coverage defined within a ± 50 -degree angle from the perpendicular bisector of the microphone linear array.

The selection criteria were constrained to using the same signature point on all microphone traces within a given pattern for the triangulation of the sound source. There are four acceptable reading points: first choice, the initial break; second choice, the point at which the zero line is first crossed; third choice, at the center of the first valley; and fourth choice, at the center of the first peak.

In this controlled experiment, situations leading to contaminated records were eliminated. The microphone traces do not contain ballistic waves or signature from multiple targets or friendly fire. However, data from Project PASS contain multiple arrivals of the same sound wave at a microphone position, thereby making it difficult to select the same signature point from all microphone traces. The sound arrival times at each microphone are manually selected and provided as input to the computing device. Meteorological parameters are measured and a sound ranging message² is calculated for input with the end result being the computation of a sound source estimate.

²A. J. Blanco, 1978, "Long-Range Artillery Sound Ranging: "PASS" Meteorological Application," ASL-TR-0014, Atmospheric Sciences Laboratory, White Sands Missile Range, NM

IMPULSE WAVE OF AN 8 INCH HOWITZER

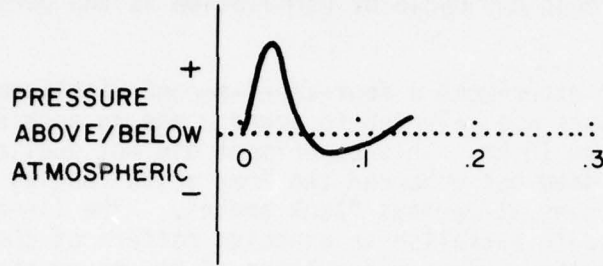

Figure 2. Impulse wave of an 8-inch howitzer has an approximate frequency of 8 cycles per second or 0.125-second period.

EXPECTED PATTERN OF ARRIVAL TIME OF A SOUND WAVE

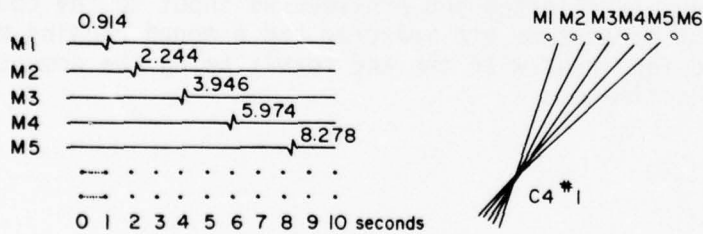

Figure 3. Expected pattern on a straight base record for C4 explosive charge at location 1.

SOUND RANGING METHOD

The sound ranging method utilized is a simple geometric⁵ model. This method depends on the relative arrival times at a pair of microphones. If it is assumed that the gun and all microphones are in the same plane, then the time difference between two adjacent microphones multiplied by the velocity of sound in the air equals the difference in distance traveled by the sound wave. Since by definition a hyperbola is the locus of points the difference of whose distance from two fixed points is constant, the sound source lies on a hyperbola whose foci are at the two adjacent microphones. Associated with each hyperbola is its asymptote which is a straight line passing through the midpoint between the foci and tangent to the hyperbola at infinity. Figure 4 shows the geometric construction that follows to calculate the direction of the sound source. The ten intersections of five direction rays are then used to determine the sound source. The figure also shows that the points of intersection for the asymptotes and the hyperbolas are not the same; therefore, a "curvature" correction is required when this geometric method is used for sound ranging.

EXPERIMENTAL DATA EDITING

The first set of fixes was calculated from the microphone record reading performed immediately after the experimental event and from meteorological messages manually calculated at the time of the experiment. The fixes containing large location errors were flagged and the corresponding microphone traces were reread. A second set of fixes was then computed using the new arrival times with edited met messages. This is the original data base for the field comparison performed at WSMR in 1974. Preliminary analysis indicated that there were large errors associated with PASS artillery sound ranging. Thus the original data base was suspected of being in error, and manual plots of the direction rays revealed a need for rereading all the original microphone records.

The automatic plotting indicated numerous cases where one direction ray was almost parallel to another. Since the intersection points will be widely distributed, the final estimate will contain a large miss. There were cases when the large polygon (2000 m) defined by the intersection of the direction rays yielded a good location but only after the centroid procedure was performed to obtain the fix. Quality research cannot be based on this type of information; therefore, a complete new reading of the microphone traces was necessary. The original meteorological data was edited for errors and a new calculation of the FM 6-15 sound ranging

⁵R. P. Lee, 1969, "A Dimensional Analysis of the Errors of Atmospheric Sound Ranging," ECOM-5236, Atmospheric Sciences Laboratory, White Sands Missile Range, NM

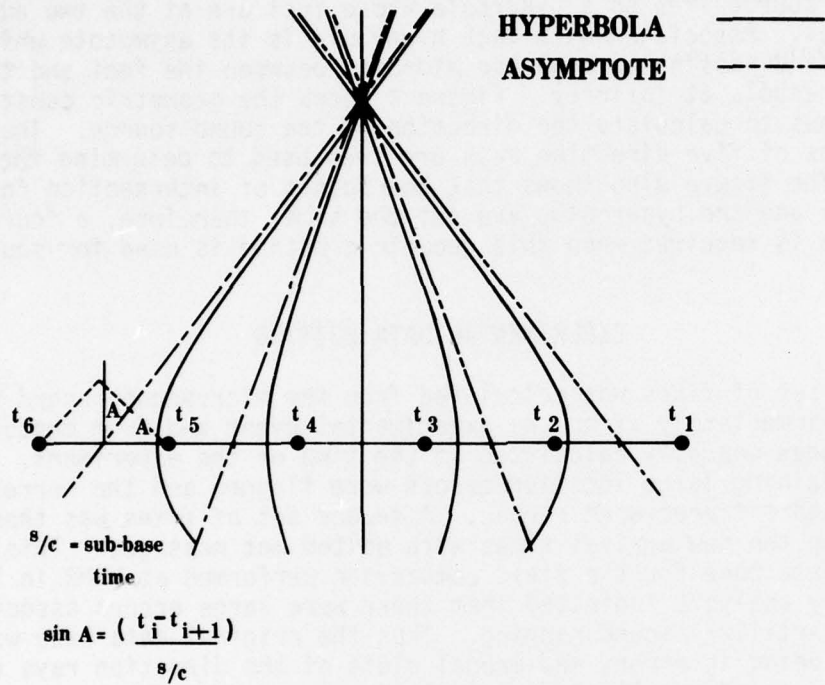

Figure 4. Fixing on a sound source by using arrival time data from a linear array of six microphones.

met messages was completed.⁶ With the automated plot available, the record reader reread the particular microphone responsible for producing wrong direction rays. This editing was performed only in cases where the particular ray was significantly separated from the cluster of the other intersections. The editing procedure automatically plots the five direction rays derived from the adjacent microphones of the regular linear array. The same procedure is currently manually performed in field application. The selected arrival times are suspected of being in error when they deviate from the assumed pattern of arrival times. The artilleryman, plotting the direction rays, identifies particular microphones that need verification of arrival time reading.

The automated processes available for the reading of the original records included the plotting of the direction rays (EDIT 1) and an aid in selecting the particular arrival time produced by a single wave passing through all six microphones (EDIT 2). Figure 5 illustrates the type of problem the record reader encounters when he needs to select from multipath arrivals. A single signature point from the common wave needs to be selected from all six microphones. The triangulation represents the fix on location 3. The first intersection represents the polygon of error defined by the "immediately read arrival times." A fix with a radial miss of about 100 m was computed. The next intersection is one derived by using manual editing from the automated plotting. Finally, the last intersection is obtained from using the automated aid of selecting the arrival times from a single pressure wave passing through all six microphones. A survey of the original microphone traces (bottom of figure 5) reveals the quality of the available data. Note that the polarity is not the same for all microphones; however, EDIT 2 aids the record reader in selecting the appropriate arrival times considering the initial polarity connection between the microphones and recorder.

The formulation for the EDIT 2 process was developed using the current method of sound ranging. The procedure is expressed in the following functional form:

relative difference of t_i 's + temperature correction + wind correction
yields direction

$$(t_i - t_{i+1}) + (t_i - t_{i+1}) \left(\sqrt{\frac{T_e}{T_{std}}} - 1 \right) + \frac{W}{\sqrt{2}} S \cos \theta = \frac{S}{C} \sin A$$

⁶E. M. D'Arcy, 1977, "PASS 500 mb Rawinsonde Data," Vol 1 and 2, ECOM-DR-74-4, Atmospheric Sciences Laboratory, White Sands Missile Range, NM

EDITING AID AUTOMATED

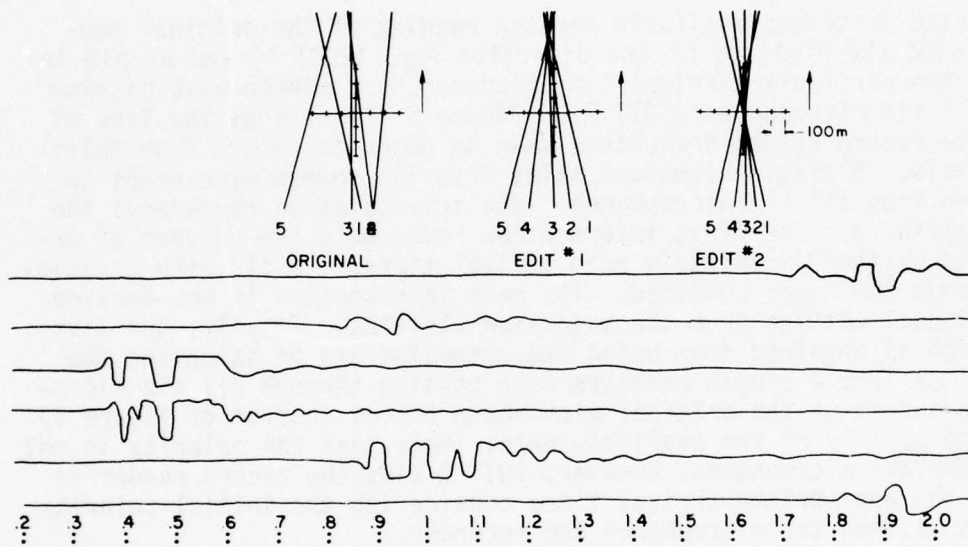

Figure 5. Automated aids available for selecting the arrival times from a single pressure wave passing through all six microphones.

$$(t_i - t_{i+1}) \sqrt{\frac{T_e}{T_{std}}} + \frac{W}{V^2} S \cos \theta = \frac{S}{C} \sin A$$

$$t_i - t_{i+1} = \left(\frac{S}{C} \sin A - \frac{W}{V^2} S \cos \theta \right) \sqrt{\frac{T_{std}}{T_e}}$$

$$t_i = t_{i+1} + \left(\frac{S}{C} \sin A - \frac{W}{V^2} S \cos \theta \right) \sqrt{\frac{T_{std}}{T_e}}$$

where

t_i = arrival time at microphone (sec)

T_e = effective temperature ($^{\circ}$ K)

T_{std} = 283.16 $^{\circ}$ K

W = effective wind speed (m/sec)

θ = angle of the effective wind direction with respect to linear array of microphones (deg)

S = distance between adjacent microphones (m)

V = speed of sound at given temperature (m/sec)

C = speed of sound at std temperature (m/sec)

A = direction of sound with respect to perpendicular bisector of S

For the operation of this editing routine, the record reader picks the best defined signal from the six microphone traces on the GR-8 record. This signal, together with the microphone positions, meteorological message, and direction of the sound source, is required input to the EDIT 2 process which will provide a display of the six computed arrival times. The reader proceeds to locate the suggested point on each microphone trace then adjusts to select the arrival times that correspond to the selection criteria (break, valley, crossover, or peak) of the trace that initiated the EDIT 2 process. The research data base for the selected arrival times is contained in the appendix. The plots of the direction rays for each fix are also included to express their corresponding polygon of error.

EXPERIMENTAL RESULTS

The original microphone traces are categorized into usable and unusable sets of data. The unusable set contained those events wherein more than two microphone traces were unreadable. More events could have been usable had proper microphone attenuation adjustment been maintained. The unusable cases are not included in this data base and the planned sample size was reduced to the ranges listed in table 2; e.g., at the bottom of column 1 the entry 74/35 indicates the total events to be 74 and the usable data to be 35. In all, more than 1/2 of the experimental data was usable.

One of the high quality traces was used to postulate the accuracy of record reading. As a sample, seven record readers (professional scientists) were provided with a particular strip chart containing information obtained from six microphone traces. The readers were instructed to read the arrival time at the "break points" of the sound signature. The results indicated a sigma range of 3 to 9 milliseconds. The most accurate reading corresponded to a microphone trace with a well-defined signature, while the largest sigma (9 milliseconds) involved a microphone trace that contained interference. As discussed in the Record Reading section, this interference can be attenuated and well-defined balanced data can be provided to the record reader.

The original results derived from using the centroid method of sound ranging are listed in table 3. Comparing the miss-location distribution with table 4 indicates the improvement afforded by the use of automated assistance in record reading. The results of interest are the computed miss-distance from the actual source location. Figure 6 contains a set of 54 fixes on a surveyed target at 11.5 km and 13 degrees flank angle. The elliptical one probable error is used to illustrate the met interaction since the arrival times from the research data base are considered the actual arrivals. The axis center indicates the location of surveyed target 2, and the radial distance from the center to any point is the sound ranging miss-distance in fixing on the target. This scatter yields a distribution about a mean distance of 5 m in the cross and 54 m in the range. Overall the results are encouraging because this probable error is within the accepted 1.5 percent of target range accuracy.

CONCLUSIONS

The research arrival time data base is available, and the effect of proposed sound ranging meteorological messages can be evaluated. The position and size of the ellipse in figure 6 can be used as an indicator for selecting the actual effective met the sound experienced as it traveled from its origin to each microphone. The time and space variability between the measured met parameters and the path of propagation should also be considered in selecting the best meteorological correction technique.

TABLE 2. C4 EXPLOSIVE CHARGES CATEGORIZED AS TO TOTAL EVENTS/USABLE DATA.

Date (1974)	Locations						
	1	2	3	4	5	6	7
1 Nov	3/1	5/5	4/2	5/2	3/0	0/0	0/0
2 Nov	7/3	9/9	7/7	6/5	7/0	0/0	0/0
4 Nov	7/1	9/2	7/1	6/1	7/0	0/0	0/0
6 Nov	3/2	5/5	4/3	4/4	4/4	0/0	0/0
7 Nov	8/3	8/2	7/4	6/6	7/6	0/0	0/0
8 Nov	2/1	5/5	4/3	4/4	4/3	0/0	0/0
11 Nov	3/1	5/1	4/0	4/0	3/0	0/0	0/0
12 Nov	3/3	5/3	4/2	4/3	4/3	0/0	0/0
14 Nov	8/4	8/0	7/3	6/4	7/6	0/0	0/0
15 Nov	6/4	7/5	8/6	6/6	5/3	0/0	0/0
18 Nov	3/1	5/4	4/4	4/4	4/1	0/0	0/0
19 Nov	2/0	3/2	2/2	2/2	1/0	2/0	9/3
20 Nov	1/0	3/1	3/0	2/1	1/0	5/2	4/0
23 Nov	3/0	4/1	4/1	4/1	2/1	9/6	9/0
26 Nov	2/1	3/1	2/0	2/0	1/0	5/4	5/3
27 Nov	2/1	3/3	2/2	2/2	1/0	5/0	5/0
2 Dec	3/2	5/4	4/3	4/3	3/1	9/6	9/5
3 Dec	2/1	3/3	2/2	2/2	1/0	7/1	5/1
5 Dec	3/3	3/2	3/2	4/4	2/0	13/0	1/0
7 Dec	3/3	6/6	6/4	5/3	2/1	11/3	11/3
	74/35	104/64	88/51	82/57	69/29	66/22	58/15

TABLE 3. CUMULATIVE FREQUENCY OF LOCATION MISSES FROM ORIGINAL ANALYSIS USING THE CENTROID METHOD OF SOUND RANGING

Target No.	1	2	3	4	5	6	7
Range (km)	11.5	11.5	11.5	11.5	11.5	16.0	16.0
Flank (deg)	25	13	0	-13	-25	-9	-23

<u>Radial Miss (m)</u>							
25	0	1	2	1	0	0	0
50	0	3	2	3	0	2	0
75	1	6	8	5	0	4	0
100	1	6	12	10	1	5	0
150	2	10	19	15	6	11	0
200	5	17	21	16	6	12	0
300	9	23	32	24	9	13	4
400	11	30	37	26	14	14	6
500	11	35	38	28	18	16	7
600	12	39	40	31	20	17	9
700	13	41	41	33	21	19	9
800	14	42	43	33	23	19	9
900	18	44	44	36	24	20	10
>1000	39	59	51	44	38	34	25

TABLE 4. CUMULATIVE FREQUENCY OF LOCATION MISSES FROM
 AUTOMATED ASSIST ANALYSIS USING THE CENTROID
 METHOD OF SOUND RANGING.

Target No.	1	2	3	4	5	6	7
Range (km)	11.5	11.5	11.5	11.5	11.5	16.0	16.0
Flank (deg)	25	13	0	-13	-25	-9	-23

Radial Miss (m)							
25	1	2	3	4	0	0	0
50	4	14	8	9	3	1	1
75	8	19	17	19	4	6	1
100	11	27	25	23	12	8	4
150	18	40	35	33	16	10	5
200	23	48	38	40	19	11	6
300	24	54	43	44	22	15	8
400	25	54	43	44	24	15	10
>400	39	59	51	44	38	34	25

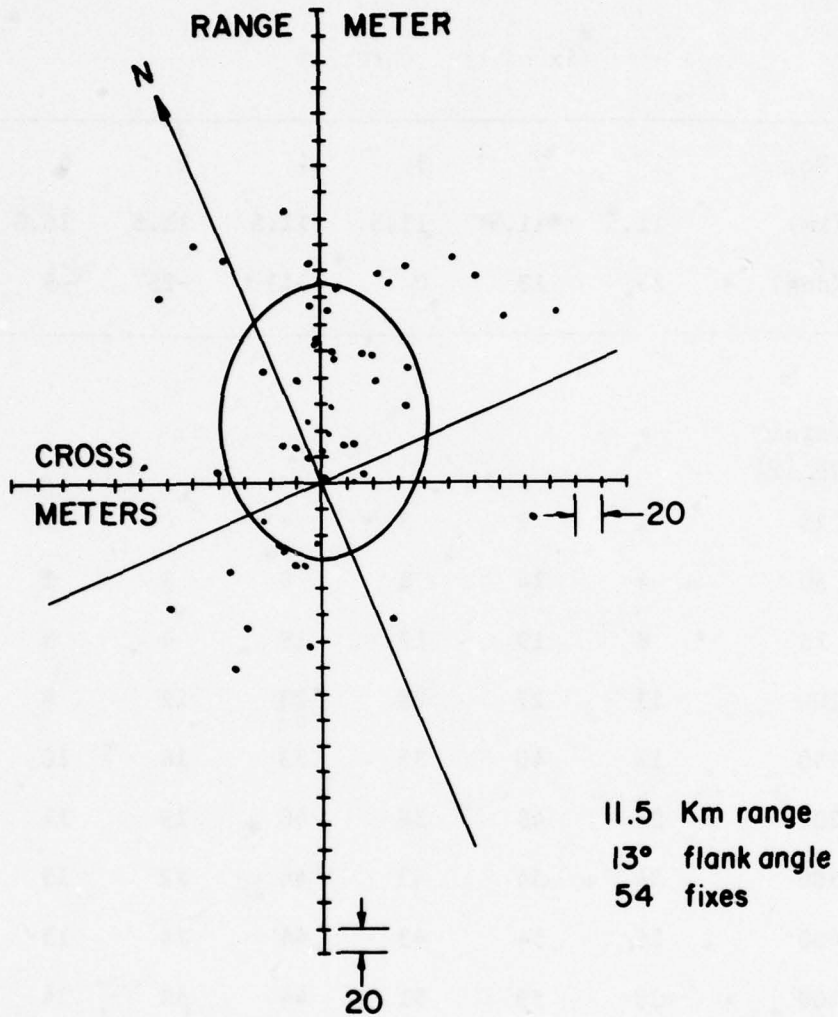

Figure 6. Illustrates the 54 fixes for source location 2 with the one probable error ellipse. The sound ranging method employed is the geometric with the centroid solution of direction ray intersection.

In comparing proposed solution algorithms, one must consider that the nature of some algorithms contains editing procedures, for example, the centroid versus the median solution. Using this data base the improvement of the median solution will be limited because the arrival times have already been adjusted to their most representative value. Therefore, the median solution will fix on the center of the ray intersection distribution which has already been edited.

A final comment that this analysis suggests is that expert supervision of adjusting microphone attenuation and reading microphone records should be maintained. If this procedure is followed, more long-range targets may be located by the sound ranging method.

REFERENCES

1. Barnett, Kenneth M., 1976, "A Description of the Artillery Meteorological Comparisons at White Sands Missile Range, October 1974-December 1974 ("PASS" - Prototype Artillery [Meteorological] Subsystem)," ECOM-5589, Atmospheric Sciences Laboratory, White Sands Missile Range, NM.
2. Blanco, Abel J., 1978, "Long-Range Artillery Sound Ranging: "PASS" Meteorological Application," ASL-TR-0014, Atmospheric Sciences Laboratory, White Sands Missile Range, NM.
3. TM 11-2568, 1945, "Sound Ranging Set GR-8," War Department Technical Manual, Headquarters, Department of the Army, Washington, D.C.
4. FM 6-122, 1964, "Artillery Sound Ranging and Flash Ranging," Department of the Army Field Manual, Headquarters, Department of the Army, Washington, D.C.
5. Lee, Robert P., 1969, "A Dimensional Analysis of the Errors of Atmospheric Sound Ranging," ECOM-5236, Atmospheric Sciences Laboratory, White Sands Missile Range, NM.
6. D'Arcy, Edward M., 1977, "PASS 500 mb Rawinsonde Data," Vol 1 and 2, ECOM-DR-74-4, Atmospheric Sciences Laboratory, White Sands Missile Range, NM.

APPENDIX

SOUND RANGING ARRIVAL TIME DATA FROM THE GR-8 DATA RECORDS COLLECTED DURING "PASS"

Table A1 identifies the fix with the date and time of day.

The data base is listed in the following format: fix number, selected arrival time for microphones 1 through 6, and met data used to make corrections on fix.² The data base is listed normalized to the earliest arrival time indicating the effect of met during the same day. Finally a plot of the direction rays is included for each of the listed cases. The wind direction and relative wind speed are also illustrated to the right of each polygon of error. The order of plots is from left to right, and the scale is 100 m per grid.

²A. J. Blanco, 1978, "Long-Range Artillery Sound Ranging: "PASS" Meteorological Application," ASL-TR-0014, Atmospheric Sciences Laboratory, White Sands Missile Range, NM.

TABLE A1. TIME OF DAY FOR EACH FIX IN DATA BASE

Date (1974)	Source Location						
	1	2	3	4	5	6	7
1 Nov	1 614 --- ---	1 414 2 514 3 626 4 712	1 655 2 738 ---	1 714 2 755 ---	---	---	---
2 Nov	---	5 501 6 540 7 656 8 741 9 818 10 855 11 1058	3 559 4 727 5 807 6 908 7 1013 8 1155	3 458 4 724 5 900 6 955 7 1120	---	---	---
4 Nov	5 458 ---	12 443 13 511	9 536 ---	8 955 ---	---	---	---
6 Nov	6 723 7 746 ---	14 658 15 819 16 845 17 931	10 741 11 833 12 927	9 649 10 721 ---	1 700 2 757 3 835 4 951	---	---
7 Nov	8 622 9 720 10 825 ---	18 632 19 737 ---	13 444 14 619 15 722 16 846 ---	11 354 12 425 13 829 14 1045	5 411 6 540 7 634 8 740 9 844 10 1033	---	---
8 Nov	---	20 1257 21 1340 22 1448 23 1535	17 1247 18 1520 19 1642	15 1336 16 1452 17 1538	11 1425 12 1523 13 1731	---	---
11 Nov	12 530	24 646	---	---	---	---	---
12 Nov	13 556 14 757	---	20 421 21 759	---	---	---	---
14 Nov	15 425 16 524 17 721 ---	---	22 454 23 724 24 1121 ---	18 356 19 839 20 930 21 1045	14 643 15 741 16 851 17 1031 18 1136	---	---
15 Nov	18 634 19 740 20 805 21 1057 ---	25 704 26 752 27 833 28 1034 29 1114 ---	25 430 26 500 27 736 28 745 29 854 30 1151	22 457 23 538 24 836 25 953 26 1204	19 637 20 800 ---	---	---
18 Nov	22 520 ---	30 455 31 558 32 810 33 849	31 419 32 601 33 751 34 808	27 452 28 516 29 706 30 754	21 721 ---	---	---
19 Nov	---	34 540 35 817 ---	---	31 613 32 716 ---	---	---	1 629 2 805 3 811
20 Nov	---	36 1339	---	---	---	1 1535	---
23 Nov	---	37 635 ---	---	33 715 ---	22 756 ---	2 805 3 1205 4 1305 5 1405	---
26 Nov	---	38 1235 23 1215	---	---	---	6 1505 ---	4 1245 5 1325 6 1522
27 Nov	24 1255 ---	39 935 40 1215 41 1315	35 955 ---	34 1015 35 1131 ---	---	---	---
2 Dec	25 515 26 856 ---	42 535 43 817 44 916 ---	36 555 37 757 38 1004 ---	36 717 37 1022 38 1115 ---	23 657 ---	7 705 8 805 9 905 10 1007 11 1105	7 545 8 625 9 825 10 1025 11 1225
3 Dec	27 545 ---	45 605 46 845 47 945	39 625 40 825	39 645 40 745	---	12 642 ---	12 527 ---
5 Dec	---	48 1135 28 1115 ---	---	41 1315 42 1615 43 1715	---	---	---
7 Dec	29 536 30 855 31 1255 ---	49 550 50 815 51 915 52 1215 53 1315 54 1515	41 603 42 755 43 1355 ---	44 615 45 715 46 1416 ---	24 658 ---	13 705 14 805 15 905 ---	13 550 14 625 15 825 ---

SOURCE 1
SOUND RANGING ARRIVAL TIMES & MET

	.1°C/10m/knots						
1	0.000	0.946	2.292	3.999	6.026	8.349	10128804
2	0.000	0.914	2.217	3.905	5.909	8.198	15535702
3	0.000	0.906	2.231	3.912	5.921	8.194	15535702
4	0.000	0.890	2.201	3.876	5.881	8.170	15535702
5	0.000	0.912	2.242	3.942	5.972	8.283	5463609
6	0.000	0.885	2.172	3.845	5.836	8.118	9063313
7	0.000	0.917	2.236	3.918	5.941	8.251	9063313
8	0.000	0.925	2.281	4.002	6.057	8.376	8511204
9	0.000	0.924	2.265	3.965	5.993	8.296	8005304
10	0.000	0.938	2.285	4.014	6.066	8.402	8005304
11	0.000	0.943	2.296	4.015	6.065	8.395	11131306
12	0.000	0.873	2.184	3.863	5.874	8.154	7063314
13	0.000	0.890	2.192	3.865	5.873	8.165	6821314
14	0.000	0.888	2.192	3.877	5.886	8.181	6821304
15	0.000	0.999	2.400	4.163	6.251	8.609	6025914
16	0.000	0.975	2.370	4.129	6.212	8.562	5526313
17	0.000	1.044	2.502	4.315	6.447	8.840	5526313
18	0.000	0.899	2.198	3.858	5.839	8.093	8833506
19	0.000	0.923	2.259	3.964	6.003	8.321	8235106
20	0.000	0.867	2.144	3.816	5.819	8.094	8235106
21	0.000	0.900	2.218	3.922	5.961	8.291	10037804
22	0.000	0.913	2.228	3.913	5.933	8.228	11146502
23	0.000	0.891	2.192	3.863	5.870	8.143	10258305
24	0.000	0.936	2.280	3.979	5.993	8.283	13240105
25	0.000	0.909	2.221	3.891	5.897	8.191	6863805
26	0.000	0.939	2.298	4.022	6.067	8.400	5200604
27	0.000	0.900	2.208	3.879	5.881	8.172	7405305
28	0.000	0.862	2.140	3.780	5.741	7.980	11841820
29	0.000	0.894	2.220	3.921	5.950	8.252	6763809
30	0.000	0.920	2.264	3.970	5.999	8.305	5663808
31	0.000	0.929	2.269	3.975	5.999	8.300	9843706

POLYGON OF ERROR PLOTS

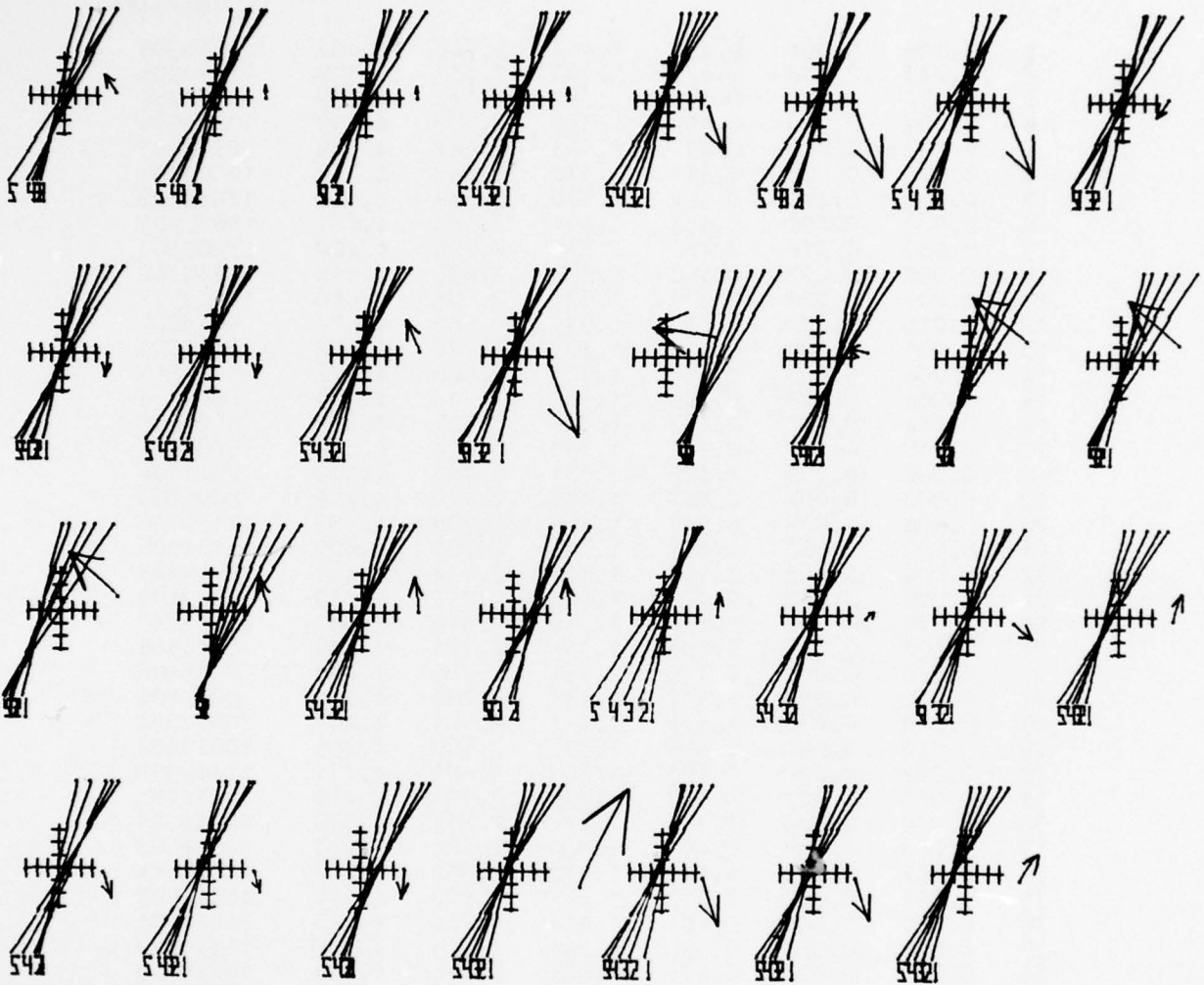

SOURCE 2

SOUND RANGING ARRIVAL TIMES & MET

.1°C/10m/knots

1	0.000	0.001	0.477	1.413	2.746	4.462	11650905
2	0.029	0.000	0.421	1.326	2.633	4.309	11650905
3	0.032	0.000	0.434	1.323	2.642	4.332	10128804
4	0.009	0.000	0.458	1.358	2.678	4.359	10128804
5	0.000	0.000	0.447	1.333	2.642	4.332	12500505
6	0.016	0.000	0.441	1.330	2.647	4.342	12500505
7	0.000	0.000	0.462	1.366	2.676	4.352	13035902
8	0.000	0.000	0.477	1.406	2.765	4.477	13035902
9	0.000	0.016	0.486	1.397	2.728	4.420	13209302
10	0.000	0.012	0.463	1.360	2.696	4.412	13209302
11	0.001	0.000	0.472	1.381	2.706	4.410	15535702
12	0.016	0.000	0.452	1.352	2.666	4.370	5463609
13	0.001	0.000	0.454	1.371	2.720	4.432	5463609
14	0.006	0.000	0.453	1.343	2.660	4.342	9063313
15	0.004	0.000	0.460	1.378	2.715	4.424	8606606
16	0.014	0.000	0.433	1.336	2.676	4.383	8606606
17	0.018	0.000	0.441	1.351	2.684	4.376	8606606
18	0.000	0.000	0.482	1.431	2.789	4.503	8511204
19	0.000	0.002	0.469	1.389	2.729	4.439	8005304
20	0.000	0.016	0.487	1.419	2.770	4.482	11131306
21	0.000	0.002	0.455	1.366	2.704	4.409	11131306
22	0.000	0.009	0.467	1.371	2.702	4.411	9929405
23	0.008	0.000	0.477	1.403	2.752	4.469	9929405
24	0.039	0.000	0.433	1.310	2.619	4.301	10361813
25	0.000	0.025	0.506	1.435	2.791	4.529	8833506
26	0.000	0.002	0.479	1.398	2.728	4.439	8235106
27	0.000	0.030	0.510	1.443	2.790	4.520	8235106
28	0.000	0.030	0.515	1.431	2.761	4.467	10037804
29	0.012	0.000	0.466	1.366	2.688	4.395	10037804
30	0.022	0.000	0.453	1.360	2.682	4.371	11146502
31	0.000	0.007	0.467	1.390	2.721	4.414	12931203
32	0.029	0.000	0.431	1.318	2.635	4.320	12931203
33	0.000	0.002	0.462	1.360	2.680	4.373	12846602
34	0.052	0.000	0.413	1.273	2.552	4.212	12846517
35	0.094	0.000	0.386	1.237	2.502	4.137	12345503
36	0.000	0.008	0.481	1.414	2.744	4.443	16211504
37	0.068	0.000	0.398	1.241	2.509	4.150	11949820
38	0.020	0.000	0.439	1.325	2.646	4.334	10258305
39	0.000	0.047	0.577	1.547	2.938	4.686	6924808
40	0.000	0.015	0.489	1.413	2.746	4.449	11647003
41	0.020	0.000	0.447	1.363	2.674	4.352	13240105
42	0.015	0.000	0.460	1.365	2.679	4.373	6863805
43	0.003	0.000	0.464	1.376	2.710	4.408	6202706
44	0.000	0.007	0.480	1.397	2.740	4.461	5200604
45	0.000	0.000	0.458	1.370	2.700	4.407	7405305
46	0.008	0.000	0.456	1.370	2.697	4.404	6403508
47	0.007	0.000	0.460	1.369	2.692	4.401	7223708
48	0.061	0.000	0.412	1.247	2.505	4.155	11841820
49	0.000	0.001	0.452	1.357	2.671	4.371	6763809
50	0.006	0.000	0.447	1.346	2.666	4.352	5461809
51	0.025	0.000	0.455	1.352	2.681	4.364	5663808
52	0.000	0.018	0.490	1.405	2.729	4.432	7960508
53	0.000	0.003	0.449	1.355	2.678	4.391	9843706
54	0.000	0.004	0.495	1.427	2.774	4.476	9843706

POLYGON OF ERROR PLOTS

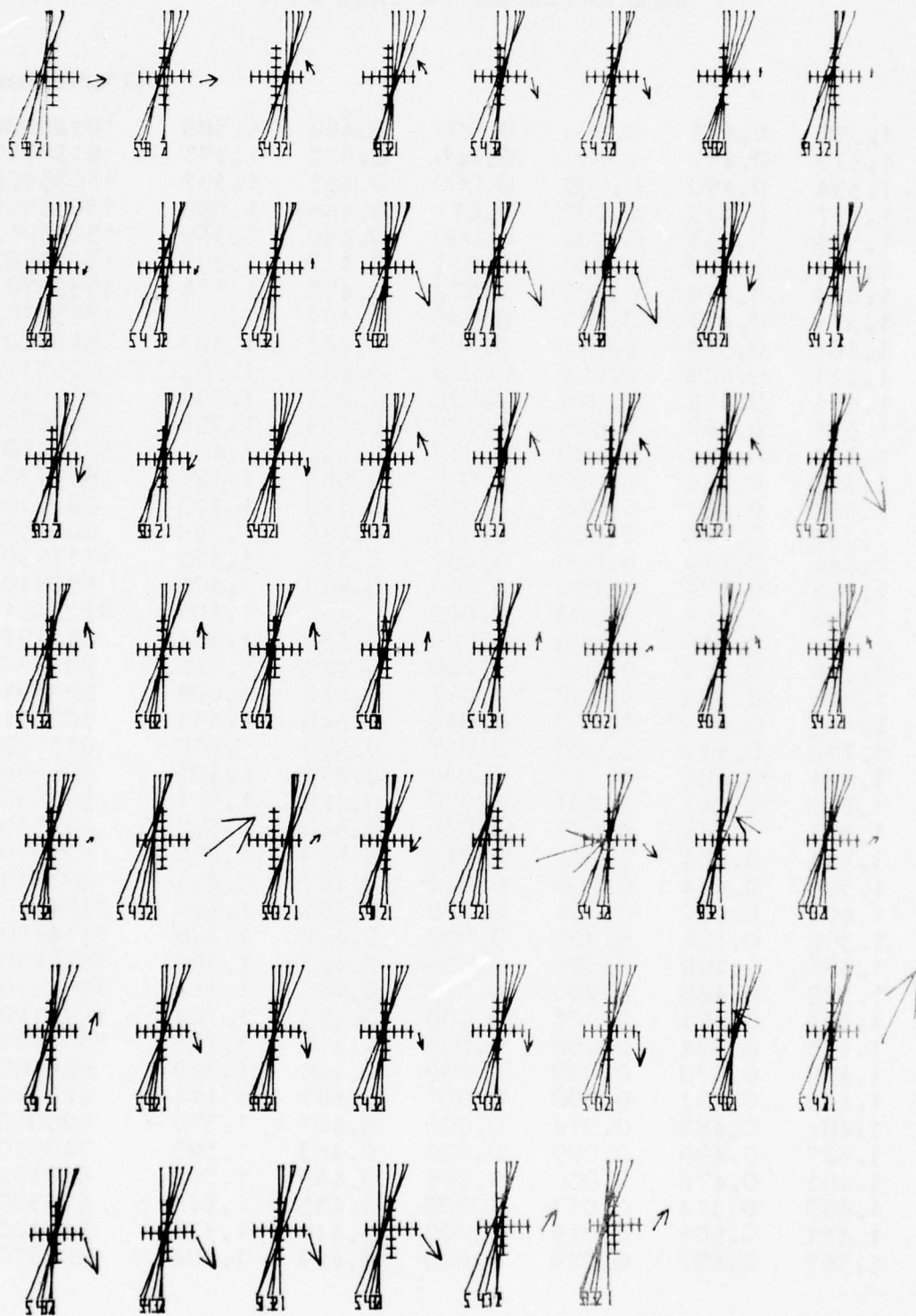

SOURCE 3

SOUND RANGING ARRIVAL TIMES & MET

							.1°C/10m/knots
1	1.388	0.471	0.009	0.000	0.468	1.388	10128804
2	1.373	0.457	0.000	0.025	0.527	1.473	8134710
3	1.394	0.480	0.003	0.000	0.481	1.392	13035902
4	1.377	0.473	0.000	0.011	0.468	1.380	13035902
5	1.373	0.463	0.000	0.000	0.460	1.369	13035902
6	1.364	0.460	0.000	0.011	0.470	1.392	13209302
7	1.379	0.474	0.000	0.002	0.475	1.376	15535702
8	1.379	0.484	0.017	0.000	0.467	1.371	15535702
9	1.464	0.534	0.040	0.000	0.441	1.321	5463609
10	1.411	0.489	0.004	0.000	0.482	1.393	9063313
11	1.401	0.492	0.012	0.000	0.474	1.391	8606606
12	1.394	0.468	0.005	0.000	0.463	1.358	8606606
13	1.338	0.449	0.000	0.023	0.520	1.471	8214603
14	1.353	0.444	0.000	0.027	0.503	1.423	8511204
15	1.387	0.467	0.000	0.012	0.499	1.415	8005304
16	1.392	0.479	0.000	0.002	0.470	1.399	8005304
17	1.344	0.449	0.000	0.002	0.476	1.421	11131306
18	1.396	0.479	0.008	0.000	0.477	1.408	9929405
19	1.368	0.451	0.000	0.009	0.487	1.409	12234310
20	1.184	0.365	0.000	0.096	0.654	1.654	8524521
21	1.405	0.483	0.009	0.000	0.449	1.350	7015905
22	1.218	0.389	0.000	0.067	0.620	1.608	6025914
23	1.199	0.373	0.000	0.090	0.640	1.634	5027311
24	1.329	0.432	0.000	0.037	0.550	1.500	8731208
25	1.421	0.489	0.011	0.000	0.472	1.405	9236604
26	1.370	0.467	0.001	0.000	0.469	1.371	9236604
27	1.371	0.469	0.007	0.000	0.466	1.377	8235106
28	1.351	0.454	0.000	0.012	0.509	1.450	8235106
29	1.389	0.474	0.005	0.000	0.467	1.401	8235106
30	1.404	0.492	0.005	0.000	0.485	1.394	11944602
31	1.396	0.486	0.006	0.000	0.468	1.388	11146502
32	1.383	0.480	0.009	0.000	0.453	1.351	12931203
33	1.329	0.448	0.000	0.015	0.497	1.416	12931203
34	1.393	0.481	0.004	0.000	0.473	1.384	12931203
35	1.313	0.434	0.000	0.059	0.577	1.536	6924808
36	1.459	0.520	0.020	0.000	0.449	1.349	6863805
37	1.429	0.484	0.000	0.007	0.487	1.411	6202706
38	1.404	0.487	0.016	0.000	0.467	1.376	5200604
39	1.427	0.499	0.009	0.000	0.463	1.393	7405305
40	1.401	0.478	0.000	0.005	0.469	1.382	6403508
41	1.463	0.514	0.017	0.000	0.435	1.342	6763809
42	1.431	0.506	0.019	0.000	0.449	1.333	5461809
43	1.387	0.482	0.015	0.000	0.469	1.404	9843706

POLYGON OF ERROR PLOTS

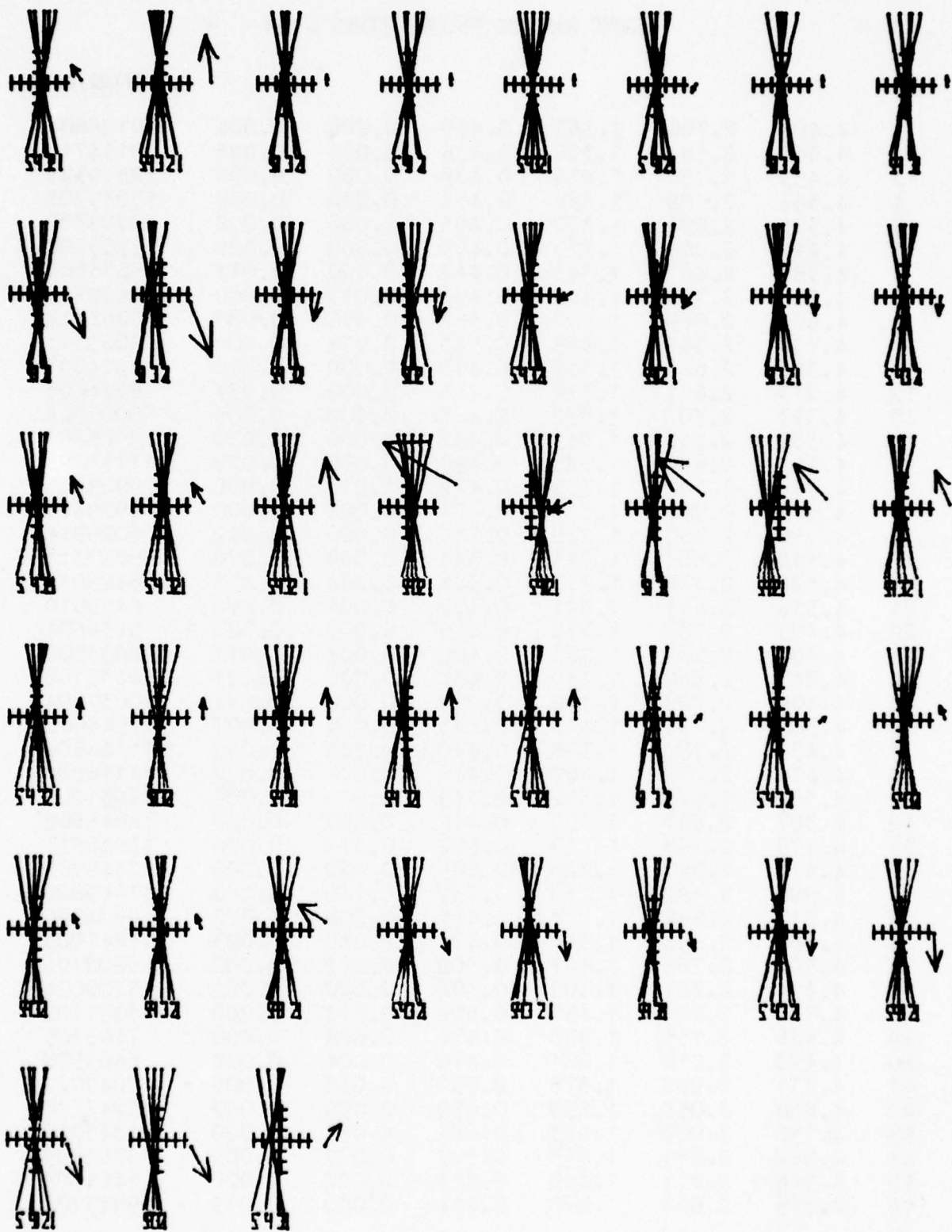

SOURCE 4

SOUND RANGING ARRIVAL TIMES & MET

.1°C/10m/knots

1	4.406	2.700	1.362	0.456	0.000	0.004	10128804
2	4.361	2.654	1.326	0.434	0.000	0.026	8134710
3	4.455	2.752	1.410	0.489	0.009	0.000	12500505
4	4.387	2.689	1.366	0.463	0.000	0.000	13035902
5	4.375	2.691	1.370	0.465	0.006	0.000	13209302
6	4.410	2.704	1.373	0.463	0.000	0.000	15535702
7	4.355	2.667	1.345	0.442	0.000	0.011	15535702
8	4.526	2.789	1.429	0.496	0.013	0.000	7600111
9	4.606	2.869	1.501	0.557	0.056	0.000	9063313
10	4.590	2.852	1.489	0.523	0.022	0.000	9063313
11	4.385	2.683	1.349	0.445	0.000	0.010	8214603
12	4.273	2.611	1.312	0.433	0.000	0.034	8214603
13	4.393	2.702	1.372	0.463	0.000	0.005	8005304
14	4.332	2.640	1.319	0.432	0.000	0.030	9905802
15	4.313	2.626	1.323	0.440	0.000	0.028	11131306
16	4.456	2.739	1.399	0.472	0.010	0.000	9929405
17	4.412	2.702	1.377	0.471	0.002	0.000	9929405
18	4.190	2.550	1.279	0.416	0.000	0.042	6025914
19	4.148	2.507	1.241	0.391	0.000	0.078	5027311
20	4.122	2.474	1.217	0.381	0.000	0.077	6425010
21	4.316	2.631	1.321	0.432	0.000	0.042	6425010
22	4.409	2.700	1.373	0.465	0.000	0.023	9236604
23	4.402	2.709	1.385	0.469	0.000	0.017	8833506
24	4.343	2.650	1.330	0.438	0.000	0.021	8235106
25	4.409	2.709	1.382	0.462	0.000	0.012	10037804
26	4.385	2.695	1.373	0.463	0.000	0.007	11944602
27	4.433	2.730	1.396	0.470	0.003	0.000	11146502
28	4.474	2.753	1.407	0.476	0.006	0.000	11146502
29	4.361	2.678	1.362	0.449	0.002	0.000	12931203
30	4.307	2.647	1.345	0.445	0.000	0.020	12846602
31	4.479	2.768	1.429	0.502	0.018	0.000	12846517
32	4.472	2.747	1.425	0.505	0.020	0.000	12345503
33	4.981	3.182	1.752	0.732	0.140	0.000	11949820
34	4.315	2.628	1.323	0.441	0.000	0.022	6924808
35	4.388	2.694	1.383	0.471	0.000	0.023	11647003
36	4.500	2.785	1.427	0.502	0.012	0.000	6202706
37	4.494	2.767	1.409	0.482	0.000	0.002	5200604
38	4.567	2.826	1.450	0.506	0.011	0.000	8001102
39	4.426	2.715	1.383	0.474	0.004	0.000	7405305
40	4.423	2.716	1.381	0.470	0.004	0.000	6403508
41	4.711	2.962	1.575	0.597	0.058	0.000	12049022
42	4.828	3.053	1.650	0.658	0.090	0.000	13247726
43	4.798	3.029	1.613	0.621	0.067	0.000	11345922
44	4.562	2.831	1.475	0.527	0.027	0.000	6763809
45	4.546	2.811	1.449	0.513	0.022	0.000	5461809
46	4.369	2.664	1.348	0.444	0.000	0.019	9843706

POLYGON OF ERROR PLOTS

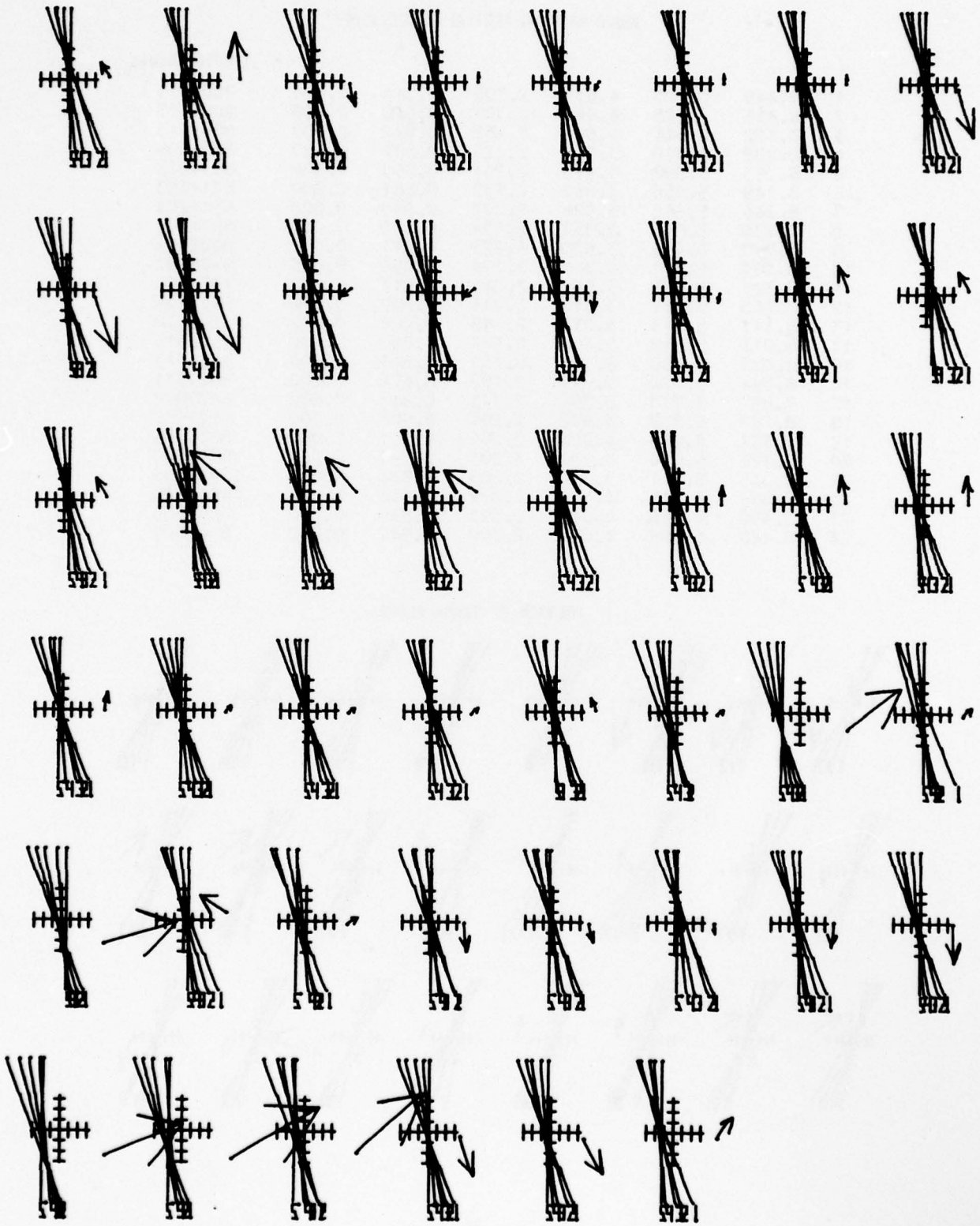

SOURCE 5

SOUND RANGING ARRIVAL TIMES & MET

							.1°C/10m/knots
1	8.449	6.103	4.039	2.309	0.941	0.000	9063313
2	8.455	6.125	4.060	2.305	0.940	0.000	9063313
3	8.122	5.844	3.844	2.167	0.872	0.000	9063313
4	8.202	5.920	3.917	2.226	0.897	0.000	8606606
5	8.293	5.990	3.950	2.234	0.909	0.000	8214603
6	8.149	5.856	3.852	2.183	0.881	0.000	8214603
7	8.244	5.945	3.926	2.227	0.900	0.000	8511204
8	8.270	5.967	3.937	2.231	0.902	0.000	8511204
9	8.250	5.949	3.920	2.225	0.911	0.000	8005304
10	8.201	5.911	3.911	2.226	0.896	0.000	9905802
11	8.327	6.006	3.961	2.245	0.913	0.000	11131306
12	8.268	5.947	3.912	2.215	0.899	0.000	9929405
13	8.111	5.835	3.830	2.148	0.868	0.000	12234310
14	8.013	5.750	3.764	2.121	0.849	0.000	5526313
15	8.023	5.768	3.788	2.131	0.841	0.000	5526313
16	8.094	5.820	3.818	2.159	0.876	0.000	5027311
17	7.997	5.730	3.755	2.113	0.846	0.000	6425010
18	8.157	5.878	3.878	2.200	0.900	0.000	6425010
19	8.354	6.039	4.000	2.286	0.911	0.000	8833506
20	8.220	5.920	3.900	2.206	0.890	0.000	8833506
21	8.245	5.937	3.910	2.209	0.884	0.000	12931203
22	8.855	6.445	4.307	2.492	1.036	0.000	11949820
23	8.390	6.070	4.021	2.291	0.939	0.000	6863805
24	8.448	6.108	4.046	2.300	0.942	0.000	6763809

POLYGON OF ERROR PLOTS

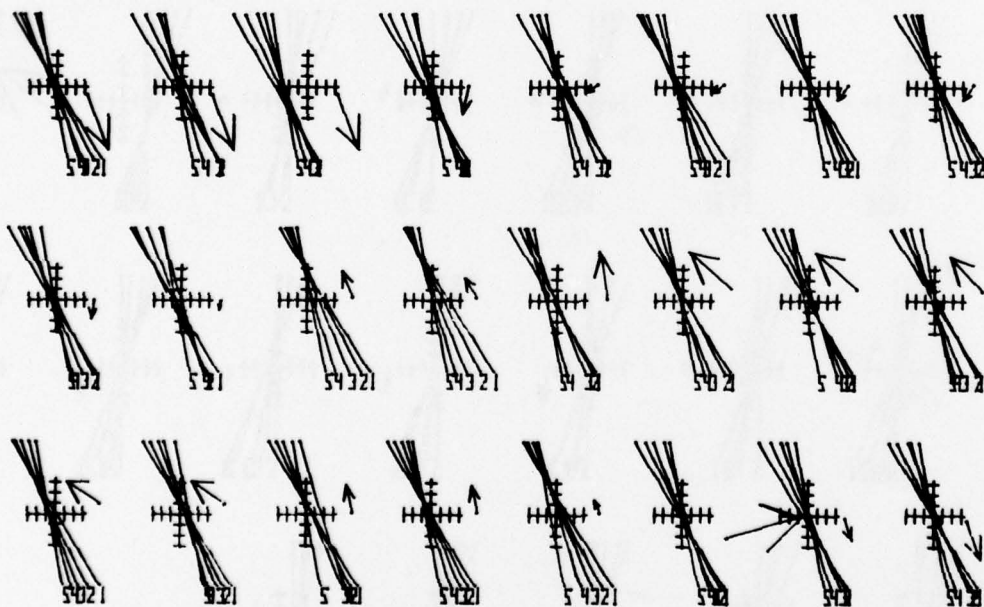

SOURCE 6

SOUND RANGING ARRIVAL TIMES & MET

							.1°C/10m/knots
1	3.334	2.057	1.063	0.375	0.008	0.000	15200205
2	3.365	2.079	1.075	0.380	0.020	0.000	11453907
3	3.471	2.155	1.125	0.404	0.021	0.000	12656407
4	3.420	2.116	1.099	0.396	0.030	0.000	12656407
5	3.524	2.211	1.143	0.439	0.008	0.000	12656407
6	3.360	2.076	1.074	0.384	0.014	0.000	15060411
7	3.423	2.121	1.114	0.392	0.010	0.000	6202706
8	3.305	2.009	1.023	0.360	0.012	0.000	6202706
9	3.380	2.068	1.073	0.370	0.018	0.000	6202706
10	3.299	2.031	1.031	0.335	0.000	0.009	5200604
11	3.356	2.060	1.049	0.359	0.000	0.003	8001102
12	3.431	2.128	1.115	0.417	0.045	0.000	7405305
13	3.501	2.172	1.141	0.427	0.039	0.000	5461809
14	3.431	2.116	1.105	0.402	0.029	0.000	5461809
15	3.454	2.145	1.118	0.407	0.026	0.000	5461809

POLYGON OF ERROR PLOTS

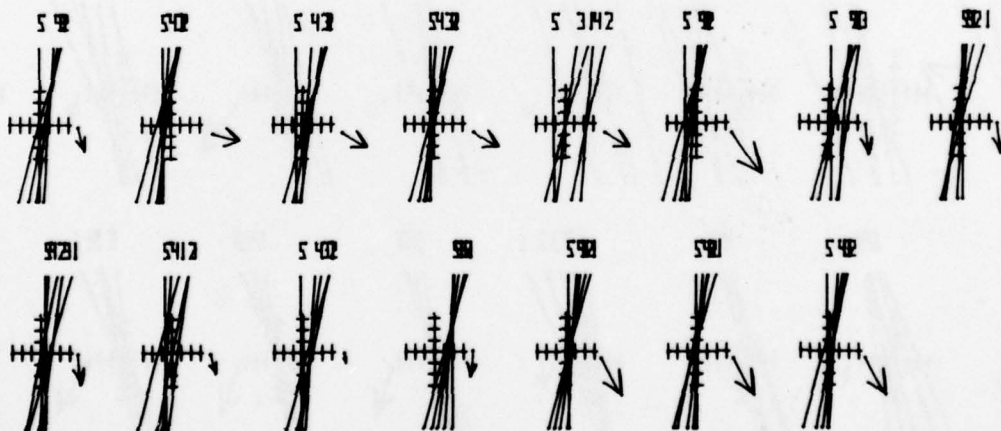

SOURCE 7

SOUND RANGING ARRIVAL TIMES & MET

							.1°C/100/knots
1	6.863	4.914	3.271	1.880	0.741	0.000	12846517
2	6.667	4.821	3.134	1.764	0.736	0.000	12345503
3	6.646	4.772	3.119	1.812	0.746	0.000	12345503
4	6.273	4.466	2.854	1.650	0.688	0.000	10258305
5	6.357	4.557	2.950	1.671	0.696	0.000	10258305
6	6.351	4.531	2.950	1.693	0.682	0.000	15060411
7	6.501	4.626	3.023	1.743	0.707	0.000	6863805
8	6.449	4.606	3.021	1.707	0.694	0.000	6863805
9	6.395	4.568	2.988	1.690	0.694	0.000	6202706
10	6.372	4.582	3.030	1.732	0.717	0.000	5200604
11	6.220	4.435	2.906	1.630	0.658	0.000	8001102
12	6.300	4.460	2.890	1.610	0.640	0.000	7405305
13	6.405	4.580	3.003	1.694	0.687	0.000	6763809
14	6.450	4.612	3.021	1.709	0.694	0.000	6763809
15	6.483	4.625	3.036	1.723	0.693	0.000	5461809

POLYGON OF ERROR PLOTS

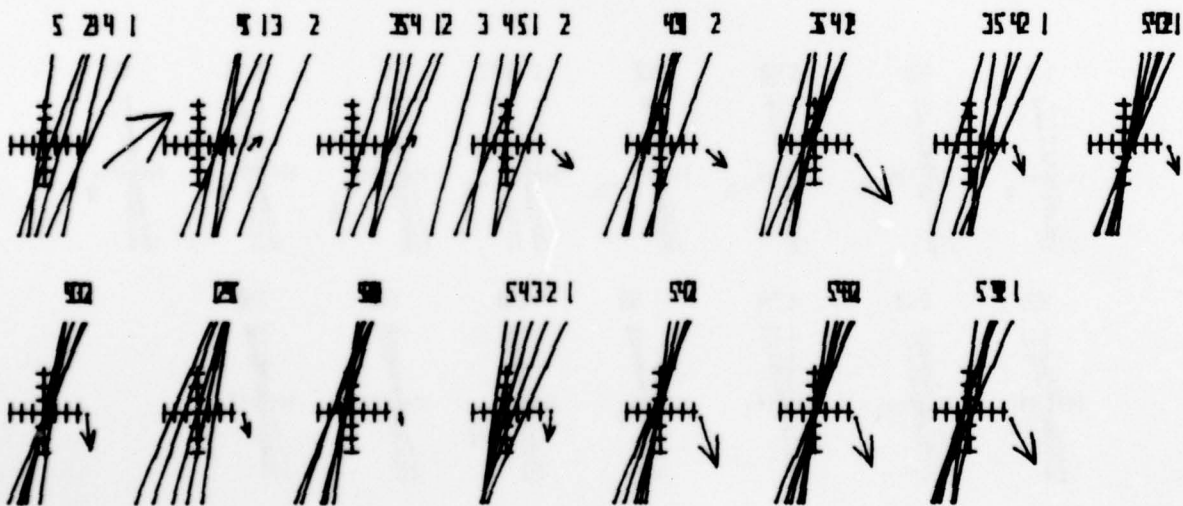

DISTRIBUTION LIST

Dr. Frank D. Eaton
Geophysical Institute
University of Alaska
Fairbanks, AK 99701

Commander
US Army Aviation Center
ATTN: ATZQ-D-MA
Fort Rucker, AL 36362

Chief, Atmospheric Sciences Div
Code ES-81
NASA
Marshall Space Flight Center,
AL 35812

Commander
US Army Missile R&D Command
ATTN: DRDMI-CGA (B. W. Fowler)
Redstone Arsenal, AL 35809

Redstone Scientific Information Center
ATTN: DRDMI-TBD
US Army Missile R&D Command
Redstone Arsenal, AL 35809

Commander
US Army Missile R&D Command
ATTN: DRDMI-TEM (R. Haraway)
Redstone Arsenal, AL 35809

Commander
US Army Missile R&D Command
ATTN: DRDMI-TRA (Dr. Essenwanger)
Redstone Arsenal, AL 35809

Commander
HQ, Fort Huachuca
ATTN: Tech Ref Div
Fort Huachuca, AZ 85613

Commander
US Army Intelligence Center & School
ATTN: ATSI-CD-MD
Fort Huachuca, AZ 85613

Commander
US Army Yuma Proving Ground
ATTN: Technical Library
Bldg 2100
Yuma, AZ 85364

Naval Weapons Center (Code 3173)
ATTN: Dr. A. Shlanta
China Lake, CA 93555

Sylvania Elec Sys Western Div
ATTN: Technical Reports Library
PO Box 205
Mountain View, CA 94040

Geophysics Officer
PMTC Code 3250
Pacific Missile Test Center
Point Mugu, CA 93042

Commander
Naval Ocean Systems Center (Code 4473)
ATTN: Technical Library
San Diego, CA 92152

Meteorologist in Charge
Kwajalein Missile Range
PO Box 67
APO San Francisco, 96555

Director
NOAA/ERL/APCL R31
RB3-Room 567
Boulder, CO 80302

Library-R-51-Tech Reports
NOAA/ERL
320 S. Broadway
Boulder, CO 80302

National Center for Atmos Research
NCAR Library
PO Box 3000
Boulder, CO 80307

R. B. Girardo
Bureau of Reclamation
E&R Center, Code 1220
Denver Federal Center, Bldg 67
Denver, CO 80225

National Weather Service
National Meteorological Center
W321, WWB, Room 201
ATTN: Mr. Quiroz
Washington, DC 20233

Mil Assistant for Atmos Sciences
Ofc of the Undersecretary of Defense
for Rsch & Engr/E&LS - Room 3D129
The Pentagon
Washington, DC 20301

Defense Communications Agency
Technical Library Center
Code 205
Washington, DC 20305

Director
Defense Nuclear Agency
ATTN: Technical Library
Washington, DC 20305

HQDA (DAEN-RDM/Dr. de Percin)
Washington, DC 20314

Director
Naval Research Laboratory
Code 5530
Washington, DC 20375

Commanding Officer
Naval Research Laboratory
Code 2627
Washington, DC 20375

Dr. J. M. MacCallum
Naval Research Laboratory
Code 1409
Washington, DC 20375

The Library of Congress
ATTN: Exchange & Gift Div
Washington, DC 20540
2

Head, Atmos Rsch Section
Div Atmospheric Science
National Science Foundation
1800 G. Street, NW
Washington, DC 20550

CPT Hugh Albers, Exec Sec
Interdept Committee on Atmos Science
National Science Foundation
Washington, DC 20550

Director, Systems R&D Service
Federal Aviation Administration
ATTN: ARD-54
2100 Second Street, SW
Washington, DC 20590

ADTC/DLODL
Eglin AFB, FL 32542

Naval Training Equipment Center
ATTN: Technical Library
Orlando, FL 32813

Det 11, 2WS/OI
ATTN: Maj Orondorff
Patrick AFB, FL 32925

USAFETAC/CB
Scott AFB, IL 62225

HQ, ESD/TOSI/S-22
Hanscom AFB, MA 01731

Air Force Geophysics Laboratory
ATTN: LCB (A. S. Carten, Jr.)
Hanscom AFB, MA 01731

Air Force Geophysics Laboratory
ATTN: LYD
Hanscom AFB, MA 01731

Meteorology Division
AFGL/LY
Hanscom AFB, MA 01731

US Army Liaison Office
MIT-Lincoln Lab, Library A-082
PO Box 73
Lexington, MA 02173

Director
US Army Ballistic Rsch Lab
ATTN: DRDAR-BLB (Dr. G. E. Keller)
Aberdeen Proving Ground, MD 21005

Commander
US Army Ballistic Rsch Lab
ATTN: DRDAR-BLP
Aberdeen Proving Ground, MD 21005

Director
US Army Armament R&D Command
Chemical Systems Laboratory
ATTN: DRDAR-CLJ-I
Aberdeen Proving Ground, MD 21010

Chief CB Detection & Alarms Div
Chemical Systems Laboratory
ATTN: DRDAR-CLC-CR (H. Tannenbaum)
Aberdeen Proving Ground, MD 21010

Commander
Harry Diamond Laboratories
ATTN: DELHD-CO
2800 Powder Mill Road
Adelphi, MD 20783

Commander
ERADCOM
ATTN: DRDEL-AP
2800 Powder Mill Road
Adelphi, MD 20783
2

Commander
ERADCOM
ATTN: DRDEL-CG/DRDEL-DC/DRDEL-CS
2800 Powder Mill Road
Adelphi, MD 20783

Commander
ERADCOM
ATTN: DRDEL-CT
2800 Powder Mill Road
Adelphi, MD 20783

Commander
ERADCOM
ATTN: DRDEL-EA
2800 Powder Mill Road
Adelphi, MD 20783

Commander
ERADCOM
ATTN: DRDEL-PA/DRDEL-ILS/DRDEL-E
2800 Powder Mill Road
Adelphi, MD 20783

Commander
ERADCOM
ATTN: DRDEL-PAO (S. Kimmel)
2800 Powder Mill Road
Adelphi, MD 20783

Chief
Intelligence Materiel Dev & Support Ofc
ATTN: DELEW-WL-I
Bldg 4554
Fort George G. Meade, MD 20755

Acquisitions Section, IRDB-D823
Library & Info Service Div, NOAA
6009 Executive Blvd
Rockville, MD 20852

Naval Surface Weapons Center
White Oak Library
Silver Spring, MD 20910

The Environmental Research
Institute of MI
ATTN: IRIA Library
PO Box 8618
Ann Arbor, MI 48107

Mr. William A. Main
USDA Forest Service
1407 S. Harrison Road
East Lansing, MI 48823

Dr. A. D. Belmont
Research Division
PO Box 1249
Control Data Corp
Minneapolis, MN 55440

Director
Naval Oceanography & Meteorology
NSTL Station
Bay St Louis, MS 39529

Director
US Army Engr Waterways Experiment Sta
ATTN: Library
PO Box 631
Vicksburg, MS 39180

Environmental Protection Agency
Meteorology Laboratory
Research Triangle Park, NC 27711

US Army Research Office
ATTN: DRXRO-PP
PO Box 12211
Research Triangle Park, NC 27709

Commanding Officer
US Army Armament R&D Command
ATTN: DRDAR-TSS Bldg 59
Dover, NJ 07801

Commander
HQ, US Army Avionics R&D Activity
ATTN: DAVAA-O
Fort Monmouth, NJ 07703

Commander/Director
US Army Combat Surveillance & Target
Acquisition Laboratory
ATTN: DELCS-D
Fort Monmouth, NJ 07703

Commander
US Army Electronics R&D Command
ATTN: DELCS-S
Fort Monmouth, NJ 07703

US Army Materiel Systems
Analysis Activity
ATTN: DRXSY-MP
Aberdeen Proving Ground, MD 21005

Director
US Army Electronics Technology &
Devices Laboratory
ATTN: DELET-D
Fort Monmouth, NJ 07703

Commander
US Army Electronic Warfare Laboratory
ATTN: DELEW-D
Fort Monmouth, NJ 07703

Commander
US Army Night Vision &
Electro-Optics Laboratory
ATTN: DELNV-L (Dr. Rudolf Buser)
Fort Monmouth, NJ 07703

Commander
ERADCOM Technical Support Activity
ATTN: DELSD-L
Fort Monmouth, NJ 07703

Project Manager, FIREFINDER
ATTN: DRCPM-FF
Fort Monmouth, NJ 07703

Project Manager, REMBASS
ATTN: DRCPM-RBS
Fort Monmouth, NJ 07703

Commander
US Army Satellite Comm Agency
ATTN: DRCPM-SC-3
Fort Monmouth, NJ 07703

Commander
ERADCOM Scientific Advisor
ATTN: DRDEL-SA
Fort Monmouth, NJ 07703

6585 TG/WE
Holloman AFB, NM 88330

AFWL/WE
Kirtland, AFB, NM 87117

AFWL/Technical Library (SUL)
Kirtland AFB, NM 87117

Commander
US Army Test & Evaluation Command
ATTN: STEWS-AD-L
White Sands Missile Range, NM 88002

Rome Air Development Center
ATTN: Documents Library
TSLD (Bette Smith)
Griffiss AFB, NY 13441

Commander
US Army Tropic Test Center
ATTN: STETC-TD (Info Center)
APO New York 09827

Commandant
US Army Field Artillery School
ATTN: ATSF-CD-R (Mr. Farmer)
Fort Sill, OK 73503

Commandant
US Army Field Artillery School
ATTN: ATSF-CF-R
Fort Sill, OK 73503

Director CFD
US Army Field Artillery School
ATTN: Met Division
Fort Sill, OK 73503

Commandant
US Army Field Artillery School
ATTN: Morris Swett Library
Fort Sill, OK 73503

Commander
US Army Dugway Proving Ground
ATTN: MT-DA-L
Dugway, UT 84022

Dr. C. R. Sreedrahan
Research Associates
Utah State University, UNC 48
Logan, UT 84322

Inge Dirmhirn, Professor
Utah State University, UNC 48
Logan, UT 84322

Defense Documentation Center
ATTN: DDC-TCA
Cameron Station Bldg 5
Alexandria, VA 22314
12

Commanding Officer
US Army Foreign Sci & Tech Center
ATTN: DRXST-IS1
220 7th Street, NE
Charlottesville, VA 22901

Naval Surface Weapons Center
Code G65
Dahlgren, VA 22448

Commander
US Army Night Vision
& Electro-Optics Lab
ATTN: DELNV-D
Fort Belvoir, VA 22060

Commander and Director
US Army Engineer Topographic Lab
ETL-TD-MB
Fort Belvoir, VA 22060

Director
Applied Technology Lab
DAVDL-EU-TSD
ATTN: Technical Library
Fort Eustis, VA 23604

Department of the Air Force
OL-C, 5WW
Fort Monroe, VA 23651

Department of the Air Force
5WW/DN
Langley AFB, VA 23665

Director
Development Center MCDEC
ATTN: Firepower Division
Quantico, VA 22134

US Army Nuclear & Chemical Agency
ATTN: MONA-WE
Springfield, VA 22150

Director
US Army Signals Warfare Laboratory
ATTN: DELSW-OS (Dr. R. Burkhardt)
Vint Hill Farms Station
Warrenton, VA 22186

Commander
US Army Cold Regions Test Center
ATTN: STECR-OP-PM
APO Seattle, WA 98733

Dr. John L. Walsh
Code 5560
Navy Research Lab
Washington, DC 20375

Commander
TRASANA
ATTN: ATAA-PL
(Dolores Anguiano)
White Sands Missile Range, NM 88002

Commander
US Army Dugway Proving Ground
ATTN: STEDP-MT-DA-M (Mr. Paul Carlson)
Dugway, UT 84022

Commander
US Army Dugway Proving Ground
ATTN: STEDP-MT-DA-T
(Mr. William Peterson)
Dugway, UT 84022

Commander
USATRADO
ATTN: ATCD-SIE
Fort Monroe, VA 23651

Commander
USATRADO
ATTN: ATCD-CF
Fort Monroe, VA 23651

Commander
USATRADO
ATTN: Tech Library
Fort Monroe, VA 23651

ATMOSPHERIC SCIENCES RESEARCH PAPERS

1. Lindberg, J.D., "An Improvement to a Method for Measuring the Absorption Coefficient of Atmospheric Dust and other Strongly Absorbing Powders," ECOM-5565, July 1975.
2. Avara, Elton P., "Mesoscale Wind Shears Derived from Thermal Winds," ECOM-5566, July 1975.
3. Gomez, Richard B., and Joseph H. Pierluissi, "Incomplete Gamma Function Approximation for King's Strong-Line Transmittance Model," ECOM-5567, July 1975.
4. Blanco, A.J., and B.F. Engebos, "Ballistic Wind Weighting Functions for Tank Projectiles," ECOM-5568, August 1975.
5. Taylor, Fredrick J., Jack Smith, and Thomas H. Pries, "Crosswind Measurements through Pattern Recognition Techniques," ECOM-5569, July 1975.
6. Walters, D.L., "Crosswind Weighting Functions for Direct-Fire Projectiles," ECOM-5570, August 1975.
7. Duncan, Louis D., "An Improved Algorithm for the Iterated Minimal Information Solution for Remote Sounding of Temperature," ECOM-5571, August 1975.
8. Robbiani, Raymond L., "Tactical Field Demonstration of Mobile Weather Radar Set AN/TPS-41 at Fort Rucker, Alabama," ECOM-5572, August 1975.
9. Miers, B., G. Blackman, D. Langer, and N. Lorimier, "Analysis of SMS/GOES Film Data," ECOM-5573, September 1975.
10. Manquero, Carlos, Louis Duncan, and Rufus Bruce, "An Indication from Satellite Measurements of Atmospheric CO₂ Variability," ECOM-5574, September 1975.
11. Petracca, Carmine, and James D. Lindberg, "Installation and Operation of an Atmospheric Particulate Collector," ECOM-5575, September 1975.
12. Avara, Elton P., and George Alexander, "Empirical Investigation of Three Iterative Methods for Inverting the Radiative Transfer Equation," ECOM-5576, October 1975.
13. Alexander, George D., "A Digital Data Acquisition Interface for the SMS Direct Readout Ground Station — Concept and Preliminary Design," ECOM-5577, October 1975.
14. Cantor, Israel, "Enhancement of Point Source Thermal Radiation Under Clouds in a Nonattenuating Medium," ECOM-5578, October 1975.
15. Norton, Colburn, and Glenn Hoidale, "The Diurnal Variation of Mixing Height by Month over White Sands Missile Range, N.M.," ECOM-5579, November 1975.
16. Avara, Elton P., "On the Spectrum Analysis of Binary Data," ECOM-5580, November 1975.
17. Taylor, Fredrick J., Thomas H. Pries, and Chao-Huan Huang, "Optimal Wind Velocity Estimation," ECOM-5581, December 1975.
18. Avara, Elton P., "Some Effects of Autocorrelated and Cross-Correlated Noise on the Analysis of Variance," ECOM-5582, December 1975.
19. Gillespie, Patti S., R.L. Armstrong, and Kenneth O. White, "The Spectral Characteristics and Atmospheric CO₂ Absorption of the Ho⁺ YLF Laser at 2.05 μ m," ECOM-5583, December 1975.
20. Novlan, David J. "An Empirical Method of Forecasting Thunderstorms for the White Sands Missile Range," ECOM-5584, February 1976.
21. Avara, Elton P., "Randomization Effects in Hypothesis Testing with Autocorrelated Noise," ECOM-5585, February 1976.
22. Watkins, Wendell R., "Improvements in Long Path Absorption Cell Measurement," ECOM-5586, March 1976.
23. Thomas, Joe, George D. Alexander, and Marvin Dubbin, "SATTEL — An Army Dedicated Meteorological Telemetry System," ECOM-5587, March 1976.
24. Kennedy, Bruce W., and Delbert Bynum, "Army User Test Program for the RDT&E-XM-75 Meteorological Rocket," ECOM-5588, April 1976.

25. Barnett, Kenneth M., "A Description of the Artillery Meteorological Comparisons at White Sands Missile Range, October 1974 - December 1974 ('PASS' - Prototype Artillery [Meteorological] Subsystem)," ECOM-5589, April 1976.
26. Miller, Walter B., "Preliminary Analysis of Fall-of-Shot From Project 'PASS'," ECOM-5590, April 1976.
27. Avara, Elton P., "Error Analysis of Minimum Information and Smith's Direct Methods for Inverting the Radiative Transfer Equation," ECOM-5591, April 1976.
28. Yee, Young P., James D. Horn, and George Alexander, "Synoptic Thermal Wind Calculations from Radiosonde Observations Over the Southwestern United States," ECOM-5592, May 1976.
29. Duncan, Louis D., and Mary Ann Seagraves, "Applications of Empirical Corrections to NOAA-4 VTPR Observations," ECOM-5593, May 1976.
30. Miers, Bruce T., and Steve Weaver, "Applications of Meteorological Satellite Data to Weather Sensitive Army Operations," ECOM-5594, May 1976.
31. Sharenow, Moses, "Redesign and Improvement of Balloon ML-566," ECOM-5595, June, 1976.
32. Hansen, Frank V., "The Depth of the Surface Boundary Layer," ECOM-5596, June 1976.
33. Pinnick, R.G., and E.B. Stenmark, "Response Calculations for a Commercial Light-Scattering Aerosol Counter," ECOM-5597, July 1976.
34. Mason, J., and G.B. Hoidale, "Visibility as an Estimator of Infrared Transmittance," ECOM-5598, July 1976.
35. Bruce, Rufus E., Louis D. Duncan, and Joseph H. Pierluissi, "Experimental Study of the Relationship Between Radiosonde Temperatures and Radiometric-Area Temperatures," ECOM-5599, August 1976.
36. Duncan, Louis D., "Stratospheric Wind Shear Computed from Satellite Thermal Sounder Measurements," ECOM-5800, September 1976.
37. Taylor, F., P. Mohan, P. Joseph and T. Pries, "An All Digital Automated Wind Measurement System," ECOM-5801, September 1976.
38. Bruce, Charles, "Development of Spectrophones for CW and Pulsed Radiation Sources," ECOM-5802, September 1976.
39. Duncan, Louis D., and Mary Ann Seagraves, "Another Method for Estimating Clear Column Radiances," ECOM-5803, October 1976.
40. Blanco, Abel J., and Larry E. Taylor, "Artillery Meteorological Analysis of Project Pass," ECOM-5804, October 1976.
41. Miller, Walter, and Bernard Engebos, "A Mathematical Structure for Refinement of Sound Ranging Estimates," ECOM-5805, November, 1976.
42. Gillespie, James B., and James D. Lindberg, "A Method to Obtain Diffuse Reflectance Measurements from 1.0 to 3.0 μm Using a Cary 17I Spectrophotometer," ECOM-5806, November 1976.
43. Rubio, Roberto, and Robert O. Olsen, "A Study of the Effects of Temperature Variations on Radio Wave Absorption," ECOM-5807, November 1976.
44. Ballard, Harold N., "Temperature Measurements in the Stratosphere from Balloon-Borne Instrument Platforms, 1968-1975," ECOM-5808, December 1976.
45. Monahan, H.H., "An Approach to the Short-Range Prediction of Early Morning Radiation Fog," ECOM-5809, January 1977.
46. Engebos, Bernard Francis, "Introduction to Multiple State Multiple Action Decision Theory and Its Relation to Mixing Structures," ECOM-5810, January 1977.
47. Low, Richard D.H., "Effects of Cloud Particles on Remote Sensing from Space in the 10-Micrometer Infrared Region," ECOM-5811, January 1977.
48. Bonner, Robert S., and R. Newton, "Application of the AN/GVS-5 Laser Rangefinder to Cloud Base Height Measurements," ECOM-5812, February 1977.
49. Rubio, Roberto, "Lidar Detection of Subvisible Reentry Vehicle Erosive Atmospheric Material," ECOM-5813, March 1977.
50. Low, Richard D.H., and J.D. Horn, "Mesoscale Determination of Cloud-Top Height: Problems and Solutions," ECOM-5814, March 1977.

51. Duncan, Louis D., and Mary Ann Seagraves, "Evaluation of the NOAA-4 VTPR Thermal Winds for Nuclear Fallout Predictions," ECOM-5815, March 1977.
52. Randhawa, Jagir S., M. Izquierdo, Carlos McDonald and Zvi Salpeter, "Stratospheric Ozone Density as Measured by a Chemiluminescent Sensor During the Stratcom VI-A Flight," ECOM-5816, April 1977.
53. Rubio, Roberto, and Mike Izquierdo, "Measurements of Net Atmospheric Irradiance in the 0.7- to 2.8-Micrometer Infrared Region," ECOM-5817, May 1977.
54. Ballard, Harold N., Jose M. Serna, and Frank P. Hudson Consultant for Chemical Kinetics, "Calculation of Selected Atmospheric Composition Parameters for the Mid-Latitude, September Stratosphere," ECOM-5818, May 1977.
55. Mitchell, J.D., R.S. Sagar, and R.O. Olsen, "Positive Ions in the Middle Atmosphere During Sunrise Conditions," ECOM-5819, May 1977.
56. White, Kenneth O., Wendell R. Watkins, Stuart A. Schleusener, and Ronald L. Johnson, "Solid-State Laser Wavelength Identification Using a Reference Absorber," ECOM-5820, June 1977.
57. Watkins, Wendell R., and Richard G. Dixon, "Automation of Long-Path Absorption Cell Measurements," ECOM-5821, June 1977.
58. Taylor, S.E., J.M. Davis, and J.B. Mason, "Analysis of Observed Soil Skin Moisture Effects on Reflectance," ECOM-5822, June 1977.
59. Duncan, Louis D. and Mary Ann Seagraves, "Fallout Predictions Computed from Satellite Derived Winds," ECOM-5823, June 1977.
60. Snider, D.E., D.G. Murcraay, F.H. Murcraay, and W.J. Williams, "Investigation of High-Altitude Enhanced Infrared Background Emissions" (U), SECRET, ECOM-5824, June 1977.
61. Dubbin, Marvin H. and Dennis Hall, "Synchronous Meteorological Satellite Direct Readout Ground System Digital Video Electronics," ECOM-5825, June 1977.
62. Miller, W., and B. Engebos, "A Preliminary Analysis of Two Sound Ranging Algorithms," ECOM-5826, July 1977.
63. Kennedy, Bruce W., and James K. Luers, "Ballistic Sphere Techniques for Measuring Atmospheric Parameters," ECOM-5827, July 1977.
64. Duncan, Louis D., "Zenith Angle Variation of Satellite Thermal Sounder Measurements," ECOM-5828, August 1977.
65. Hansen, Frank V., "The Critical Richardson Number," ECOM-5829, September 1977.
66. Ballard, Harold N., and Frank P. Hudson (Compilers), "Stratospheric Composition Balloon-Borne Experiment," ECOM-5830, October 1977.
67. Barr, William C., and Arnold C. Peterson, "Wind Measuring Accuracy Test of Meteorological Systems," ECOM-5831, November 1977.
68. Ethridge, G.A. and F.V. Hansen, "Atmospheric Diffusion: Similarity Theory and Empirical Derivations for Use in Boundary Layer Diffusion Problems," ECOM-5832, November 1977.
69. Low, Richard D.H., "The Internal Cloud Radiation Field and a Technique for Determining Cloud Blackness," ECOM-5833, December 1977.
70. Watkins, Wendell R., Kenneth O. White, Charles W. Bruce, Donald L. Walters, and James D. Lindberg, "Measurements Required for Prediction of High Energy Laser Transmission," ECOM-5834, December 1977.
71. Rubio, Robert, "Investigation of Abrupt Decreases in Atmospherically Backscattered Laser Energy," ECOM-5835, December 1977.
72. Monahan, H.H. and R.M. Cionco, "An Interpretative Review of Existing Capabilities for Measuring and Forecasting Selected Weather Variables (Emphasizing Remote Means)," ASL-TR-0001, January 1978.
73. Heaps, Melvin G., "The 1979 Solar Eclipse and Validation of D-Region Models," ASL-TR-0002, March 1978.

74. Jennings, S.G., and J.B. Gillespie, "M.I.E. Theory Sensitivity Studies - The Effects of Aerosol Complex Refractive Index and Size Distribution Variations on Extinction and Absorption Coefficients Part II: Analysis of the Computational Results," ASL-TR-0003, March 1978.
75. White, Kenneth O. et al, "Water Vapor Continuum Absorption in the 3.5 μ m to 4.0 μ m Region," ASL-TR-0004, March 1978.
76. Olsen, Robert O., and Bruce W. Kennedy, "ABRES Pretest Atmospheric Measurements," ASL-TR-0005, April 1978.
77. Ballard, Harold N., Jose M. Serna, and Frank P. Hudson, "Calculation of Atmospheric Composition in the High Latitude September Stratosphere," ASL-TR-0006, May 1978.
78. Watkins, Wendell R. et al, "Water Vapor Absorption Coefficients at HF Laser Wavelengths," ASL-TR-0007, May 1978.
79. Hansen, Frank V., "The Growth and Prediction of Nocturnal Inversions," ASL-TR-0008, May 1978.
80. Samuel, Christine, Charles Bruce, and Ralph Brewer, "Spectrophone Analysis of Gas Samples Obtained at Field Site," ASL-TR-0009, June 1978.
81. Pinnick, R.G. et al., "Vertical Structure in Atmospheric Fog and Haze and its Effects on IR Extinction," ASL-TR-0010, July 1978.
82. Low, Richard D.H., Louis D. Duncan, and Richard B. Gomez, "The Microphysical Basis of Fog Optical Characterization," ASL-TR-0011, August 1978.
83. Heaps, Melvin G., "The Effect of a Solar Proton Event on the Minor Neutral Constituents of the Summer Polar Mesosphere," ASL-TR-0012, August 1978.
84. Mason, James B., "Light Attenuation in Falling Snow," ASL-TR-0013, August 1978.
85. Blanco, Abel J., "Long-Range Artillery Sound Ranging: "PASS" Meteorological Application," ASL-TR-0014, September 1978.
86. Heaps, M.G., and F.E. Niles, "Modeling the Ion Chemistry of the D-Region: A case Study Based Upon the 1966 Total Solar Eclipse," ASL-TR-0015, September 1978.
87. Jennings, S.G., and R.G. Pinnick, "Effects of Particulate Complex Refractive Index and Particle Size Distribution Variations on Atmospheric Extinction and Absorption for Visible Through Middle-Infrared Wavelengths," ASL-TR-0016, September 1978.
88. Watkins, Wendell R., Kenneth O. White, Lanny R. Bower, and Brian Z. Sojka, "Pressure Dependence of the Water Vapor Continuum Absorption in the 3.5- to 4.0-Micrometer Region," ASL-TR-0017, September 1978.
89. Miller, W.B., and B.F. Engebos, "Behavior of Four Sound Ranging Techniques in an Idealized Physical Environment," ASL-TR-0018, September 1978.
90. Gomez, Richard G., "Effectiveness Studies of the CBU-88/B Bomb, Cluster, Smoke Weapon" (U), CONFIDENTIAL ASL-TR-0019, September 1978.
91. Miller, August, Richard C. Shirkey, and Mary Ann Seagraves, "Calculation of Thermal Emission from Aerosols Using the Doubling Technique," ASL-TR-0020, November, 1978.
92. Lindberg, James D. et al., "Measured Effects of Battlefield Dust and Smoke on Visible, Infrared, and Millimeter Wavelengths Propagation: A Preliminary Report on Dusty Infrared Test-I (DIRT-I)," ASL-TR-0021, January 1979.
93. Kennedy, Bruce W., Arthur Kinghorn, and B.R. Hixon, "Engineering Flight Tests of Range Meteorological Sounding System Radiosonde," ASL-TR-0022, February 1979.
94. Rubio, Roberto, and Don Hoock, "Microwave Effective Earth Radius Factor Variability at Wiesbaden and Balboa," ASL-TR-0023, February 1979.
95. Low, Richard D.H., "A Theoretical Investigation of Cloud/Fog Optical Properties and Their Spectral Correlations," ASL-TR-0024, February 1979.

96. Pinnick, R.G., and H.J. Auvermann, "Response Characteristics of Knollenberg Light-Scattering Aerosol Counters," ASL-TR-0025, February 1979.
97. Heaps, Melvin G., Robert O. Olsen, and Warren W. Berning, "Solar Eclipse 1979, Atmospheric Sciences Laboratory Program Overview," ASL-TR-0026
February 1979
98. Blanco, Able J., "Long-Range Artillery Sound Ranging: 'PASS' GR-8 Sound Ranging Data," ASL-TR-0027, March 1979