

AD-A070 290

ARMY MISSILE RESEARCH AND DEVELOPMENT COMMAND REDSTO--ETC F/G 19/5
FLIGHT TEST RESULTS OF A VIRTUAL IMAGE, PANTOGRAPH MOUNTED, CON--ETC(U)
FEB 79 M C PITRUZZELLO
DRDMI-T-79-33

UNCLASSIFIED

NL

| OF |
AD
A070290



END
DATE
FILMED
7-79
DDC

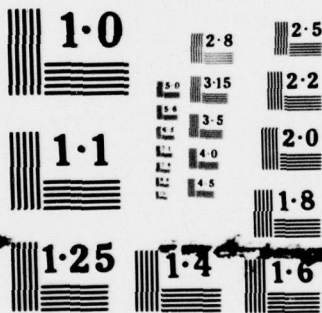

NATIONAL BUREAU OF STANDARDS
MICROCOPY RESOLUTION TEST CHART

ADA 070290



U.S. ARMY
MISSILE
RESEARCH
AND
DEVELOPMENT
COMMAND



Redstone Arsenal, Alabama 35809

DDC FILE COPY

DMI FORM 1000, 1 APR 77

LEVEL II

12
WAW

14 DRDMI-T-79-33

9 TECHNICAL REPORT T-79-33

6 FLIGHT TEST RESULTS OF A VIRTUAL IMAGE,
PANTOGRAPH MOUNTED, CONTROL AND
DISPLAY STATION.

10 Michael C. Pitruzzello
Guidance and Control Directorate
Technology Laboratory

11 23 February 1979
12 29p.

Approved for Public Release.
Distribution Unlimited

DDC
RECEIVED
JUN 25 1979
RESERVED

393427

A

LB

79 06 23 051

DISPOSITION INSTRUCTIONS

DESTROY THIS REPORT WHEN IT IS NO LONGER NEEDED. DO NOT RETURN IT TO THE ORIGINATOR.

DISCLAIMER

THE FINDINGS IN THIS REPORT ARE NOT TO BE CONSTRUED AS AN OFFICIAL DEPARTMENT OF THE ARMY POSITION UNLESS SO DESIGNATED BY OTHER AUTHORIZED DOCUMENTS.

TRADE NAMES

USE OF TRADE NAMES OR MANUFACTURERS IN THIS REPORT DOES NOT CONSTITUTE AN OFFICIAL ENDORSEMENT OR APPROVAL OF THE USE OF SUCH COMMERCIAL HARDWARE OR SOFTWARE.

Approved For Release	
FORM 100-1	<input checked="" type="checkbox"/>
FORM 100-2	<input type="checkbox"/>
Unapproved	<input type="checkbox"/>
Justification	
By _____	
Distribution/	
Availability Codes	
Dis	Avail and/or special
A	

Unclassified

SECURITY CLASSIFICATION OF THIS PAGE (When Data Entered)

REPORT DOCUMENTATION PAGE		READ INSTRUCTIONS BEFORE COMPLETING FORM
1. REPORT NUMBER T-79-33	2. GOVT ACCESSION NO.	3. RECIPIENT'S CATALOG NUMBER
4. TITLE (and Subtitle) Flight Test Results of a Virtual Image, Pantograph Mounted, Control and Display Station		5. TYPE OF REPORT & PERIOD COVERED Technical Report
		6. PERFORMING ORG. REPORT NUMBER
7. AUTHOR(s) Michael C. Pitruzzello		8. CONTRACT OR GRANT NUMBER(s)
9. PERFORMING ORGANIZATION NAME AND ADDRESS Commander US Army Missile Research and Development Command ATTN: DRDMI-T&G Redstone Arsenal, Alabama 35809		10. PROGRAM ELEMENT, PROJECT, TASK AREA & WORK UNIT NUMBERS
11. CONTROLLING OFFICE NAME AND ADDRESS Commander US Army Missile Research and Development Command ATTN: DRDMI-TI Redstone Arsenal, Alabama 35809		12. REPORT DATE 23 February 1979
		13. NUMBER OF PAGES 16
14. MONITORING AGENCY NAME & ADDRESS (if different from Controlling Office)		15. SECURITY CLASS. (of this report) Unclassified
		15a. DECLASSIFICATION/DOWNGRADING SCHEDULE
16. DISTRIBUTION STATEMENT (of this Report) Approved for Public Release; Distribution Unlimited.		
17. DISTRIBUTION STATEMENT (of the abstract entered in Block 20, if different from Report)		
18. SUPPLEMENTARY NOTES		
19. KEY WORDS (Continue on reverse side if necessary and identify by block number) Pantograph Gimbal SPAL POD COBRA		
20. ABSTRACT (Continue on reverse side if necessary and identify by block number) A growing number of US Army programs requires target detection and identification at long stand-off ranges from airborne (helicopter) platforms. One method that is currently being pursued to meet this requirement is to provide the helicopter gunner with a precision stabilized optical or electro-optical sighting system. Unfortunately, the required optical magnification requires a small angular field-of-view. This can result in excessive target search times during which the helicopter may be vulnerable to enemy fire.		

DD FORM 1473 1 JAN 73

EDITION OF 1 NOV 65 IS OBSOLETE

Unclassified

SECURITY CLASSIFICATION OF THIS PAGE (When Data Entered)

CONTENTS

Section	Page
1. Introduction	3
2. Equipment Description	7
3. Test Details	11
4. Conclusions	15

ILLUSTRATIONS

Figure	Page
1. Front view of Pantograph mounted display station.	4
2. Oblique view of Pantograph mounted display station showing size of unit.	5
3. Close-Up View of Pantograph Mounted Display Station.	6
4. Gimbal Arrangement of the Display Station.	8
5. The SPAL Pod Mounted on the Right Outboard Wing of an AH-1G COBRA.	9
6. SPAL Servo Block Diagram Showing Inputs from Pantograph.	10
7. Functional Diagram of the Airborne Sighting System.	12

1. INTRODUCTION

A growing number of US Army programs requires target detection and identification at long stand-off ranges from airborne (helicopter) platforms. One method that is currently being pursued to meet this requirement is to provide the helicopter gunner with a precision stabilized optical or electro-optical sighting system. Unfortunately, the required optical magnification requires a small angular field-of-view. This can result in excessive target search times during which the helicopter may be vulnerable to enemy fire.

Some possible solutions to excessive search times are as follows:

- Addition to the sighting system of another field-of-view which is wide enough to ensure short search times yet narrow enough to ensure target detection.
- Target prebriefing which would allow the onboard fire control computer to aim the sighting system in the target's vicinity automatically. Of course, this requires target prebriefing, a fire control computer, and an attitude and position reference for the helicopter.
- A cuing aid which, on command, would slave the sighting system to the gunner's line-of-sight, thus taking advantage of the human eye's good resolution and wide field-of-view.

This report is an evaluation of a pantograph mounted display station designed to shorten search times by slaving a narrow field-of-view sighting system to the gunner's line-of-sight. The display station, shown in *Figures 1, 2, and 3*, incorporates a gimballed platform to which are mounted the sighting system control grips and a unique virtual image TV display. Theoretical advantages of this mechanization are the following:

- The virtual image display is less prone to sun "washout" than a panel mounted display.
- The operator suffers less orientation problem than with a helmet sight/panel mounted display since the TV display and boresight reticle move together.

In order to evaluate the relative merits of this display station, a short flight test program was initiated using the equipment described in the next section.

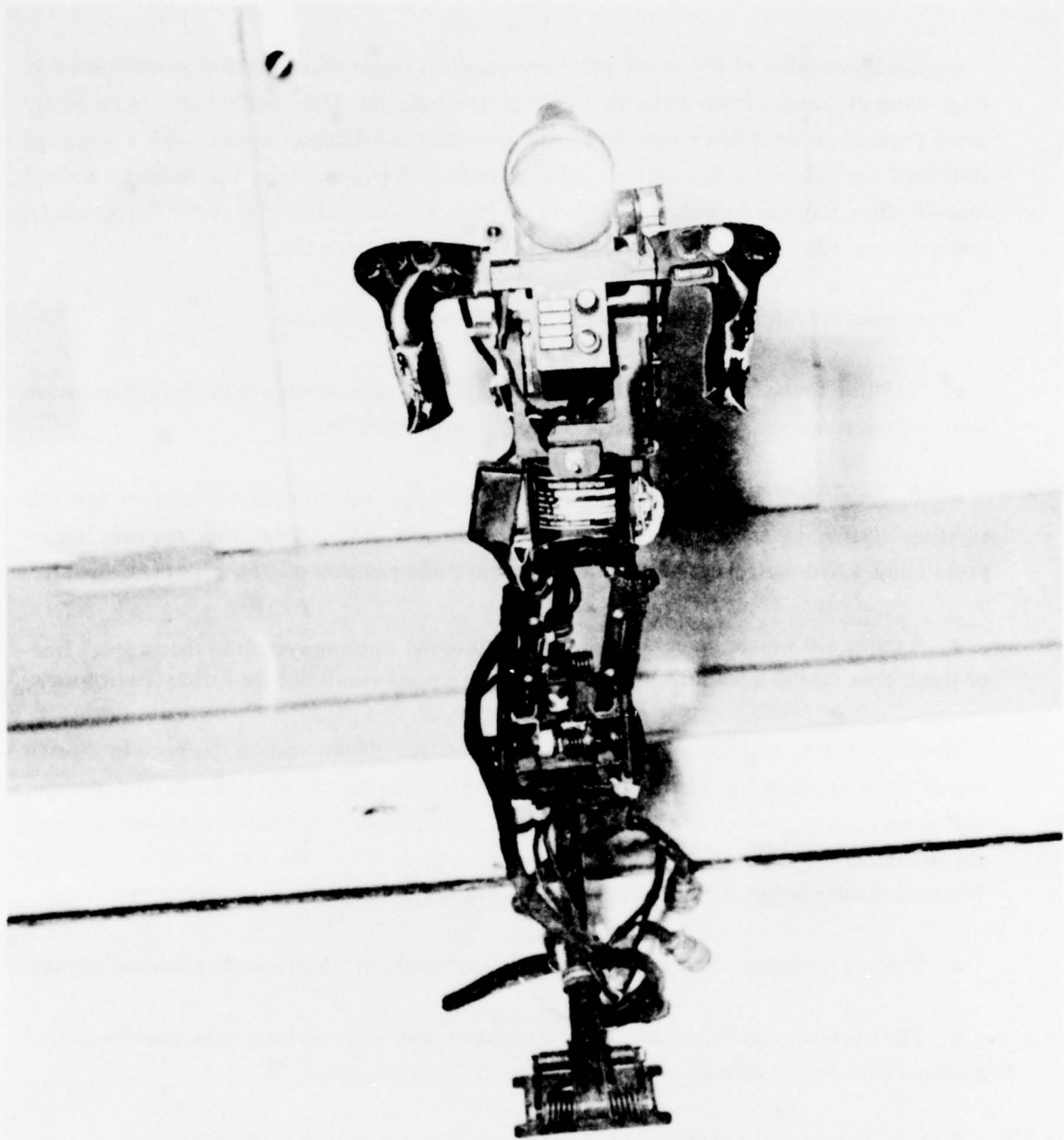

Figure 1. Front view of pantograph mounted display station.

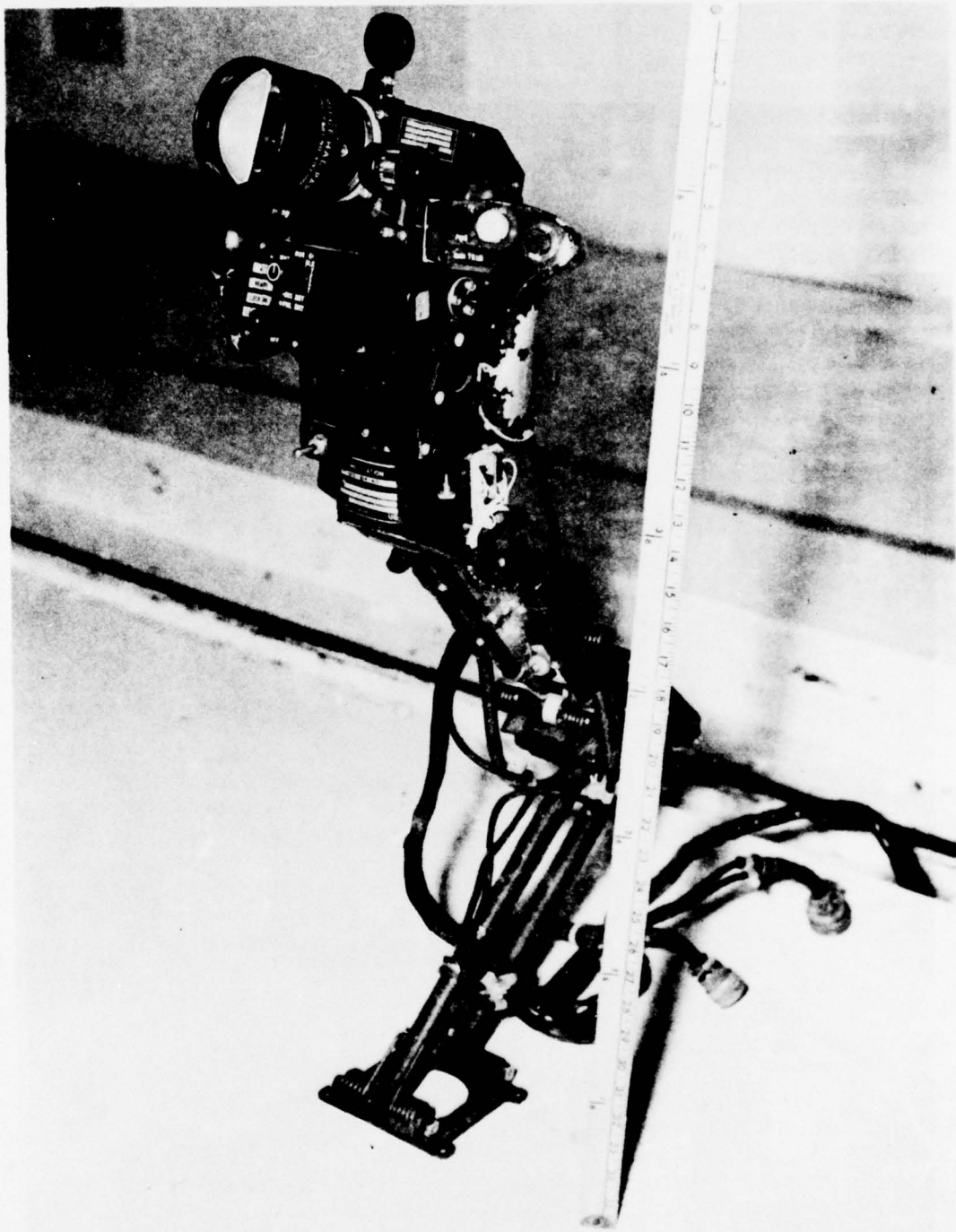

Figure 2. Oblique view of pantograph mounted display station showing size of unit.

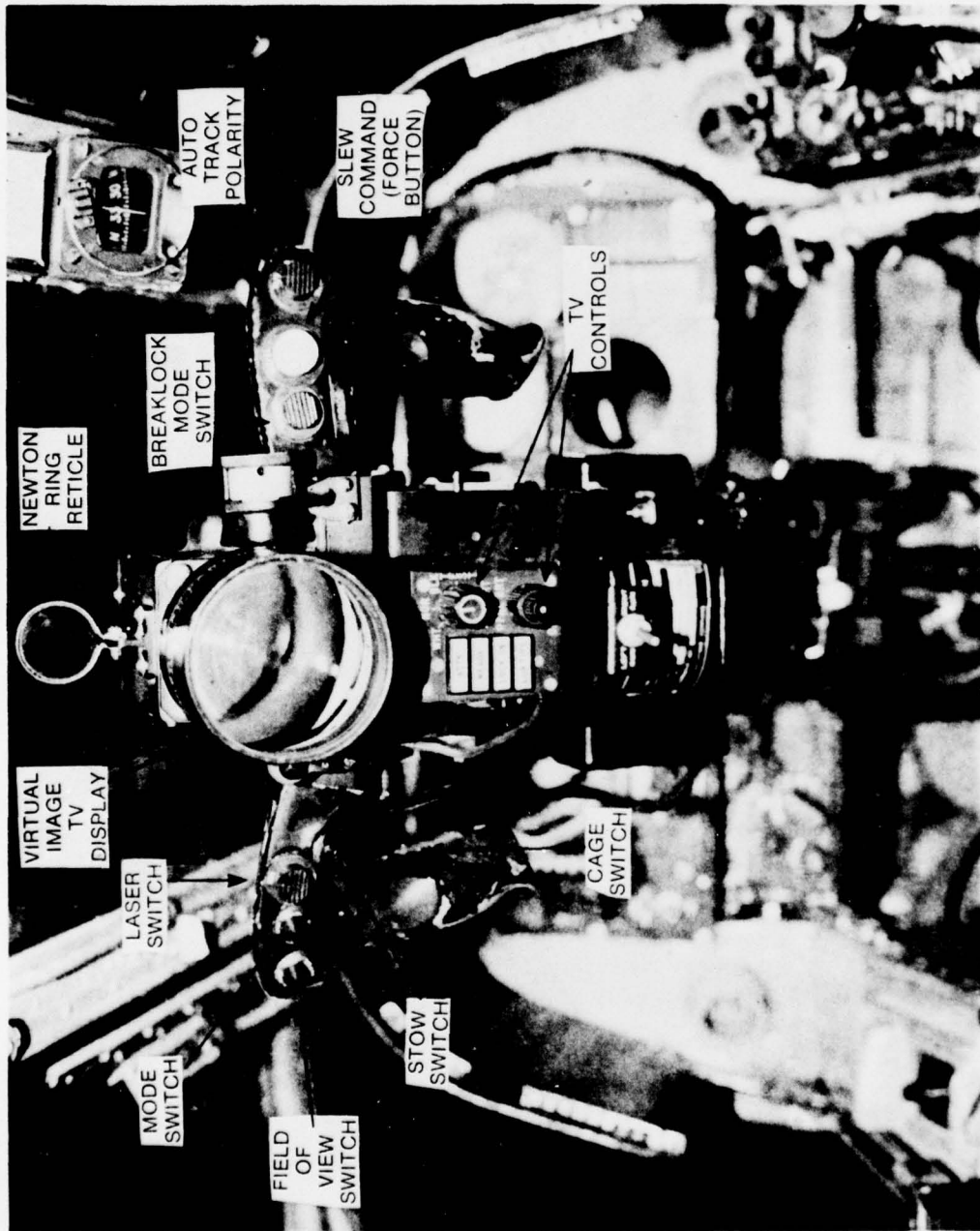

Figure 3. Close-up view of pantograph mounted display station.

2. EQUIPMENT DESCRIPTION

The pantograph unit under test is a unique combination of controls and displays. In *Figure 3*, the two handgrips contain all switches necessary to control the sighting system. The virtual image TV display contains a 1.3 in. (3.3-cm) diameter CRT and expanding optics to create an apparent 26° field-of-view virtual image. Some of the pertinent display data are shown in *Table 1*. The controls/display unit is attached to a gimballed base which contains azimuth and elevation gimbal angle pick-offs (see *Figure 4*). On top of the TV display (see *Figure 3*) is mounted a concentric ring (formed optically by Newton rings) reticle which appears projected to infinity. (Unfortunately, these rings do not appear in the photograph of *Figure 3*.) When the gunner selects the proper operating mode, the SPAL line-of-sight is slaved to the center of the reticle by means of the pantograph gimbal angle pick-offs. Thus, when the gunner places the reticle center on the target, the target will appear in the TV display.

TABLE 1. TV DISPLAY CHARACTERISTICS

CRT size	1.3-inch Diameter
Phosphor	P1
Spot Size	0.8 mil
Brightness	48 ft L (includes Loss Due to Optics)
Field-of-View	26°

To evaluate the display station, an airborne precision stabilized sighting system was necessary. The Stabilized Platform Airborne Laser (SPAL) system was chosen because of its availability, performance and narrow fields-of-view. This system contains a two-field-of-view TV camera, TV contrast automatic tracker and precision stabilized gimbal set mounted in a 327-lb (147-kg) pod. *Figure 5* shows the SPAL pod mounted on the right wing of an AH-1G helicopter.

As shown in *Figure 6*, the SPAL system contains three servo systems. The heart of the servos is the rate stabilization servo. This high gain, high bandwidth servo's main function is to isolate the SPAL line-of-sight from helicopter vibration. The rate servo can be driven by one of three sources selected by S1. In the slave mode, the drive signal is the difference between the SPAL gimbal angles (referenced to the helicopter) and the pantograph gimbal angles. Thus, the SPAL line-of-sight is essentially slaved to the pantograph reticle. In the manual track mode, the rate servo is driven by the pantograph slew command signals. In the auto track mode, the rate servo is driven by the difference between the SPAL line-of-sight and the line-of-sight to the target as generated by the TV autotracker. The position of mode control switch S1 is selected by the mode switch (see *Figure 3*) buffered by the interface box as described in the following paragraph.

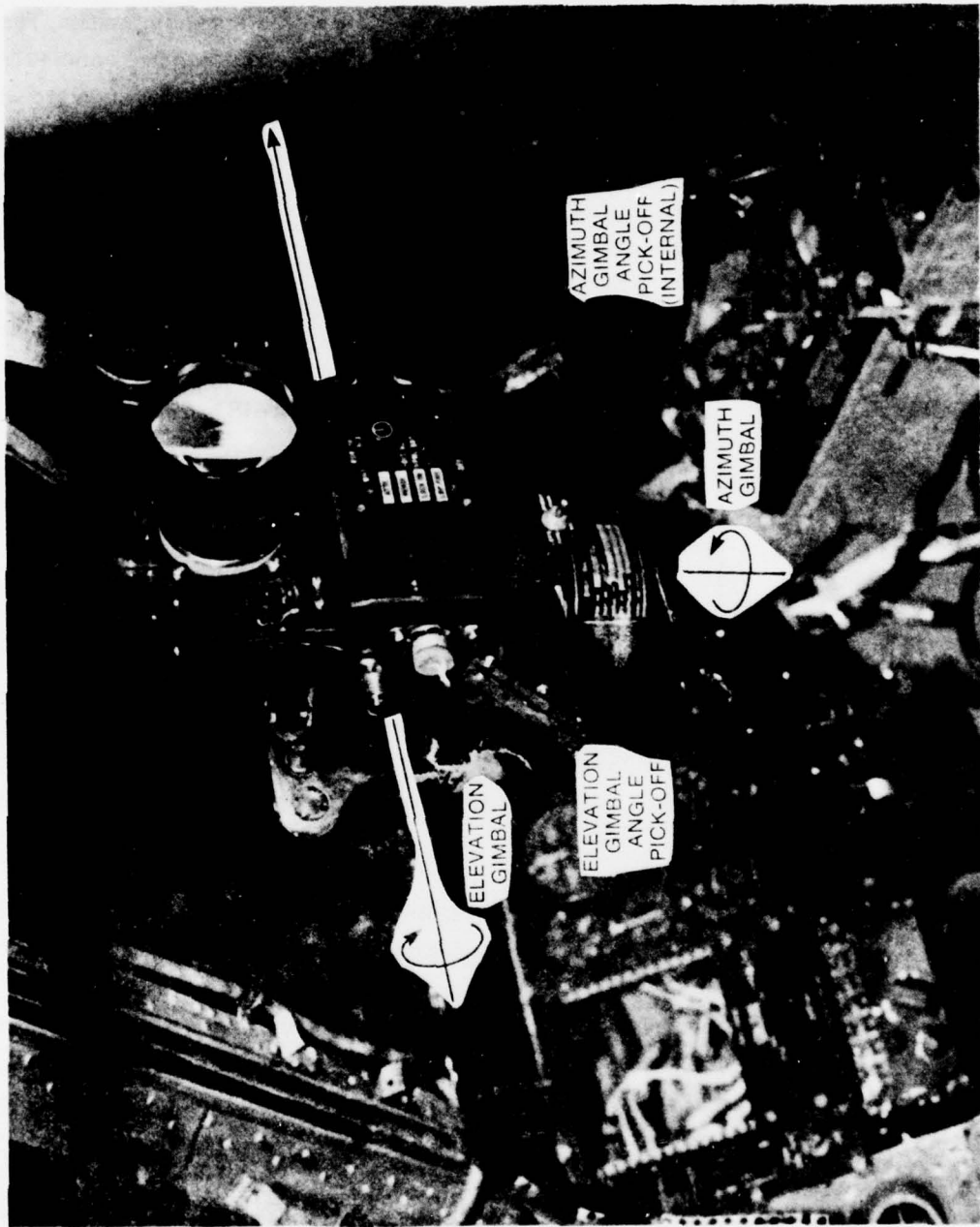

Figure 4. Gimbal arrangement of the display station.

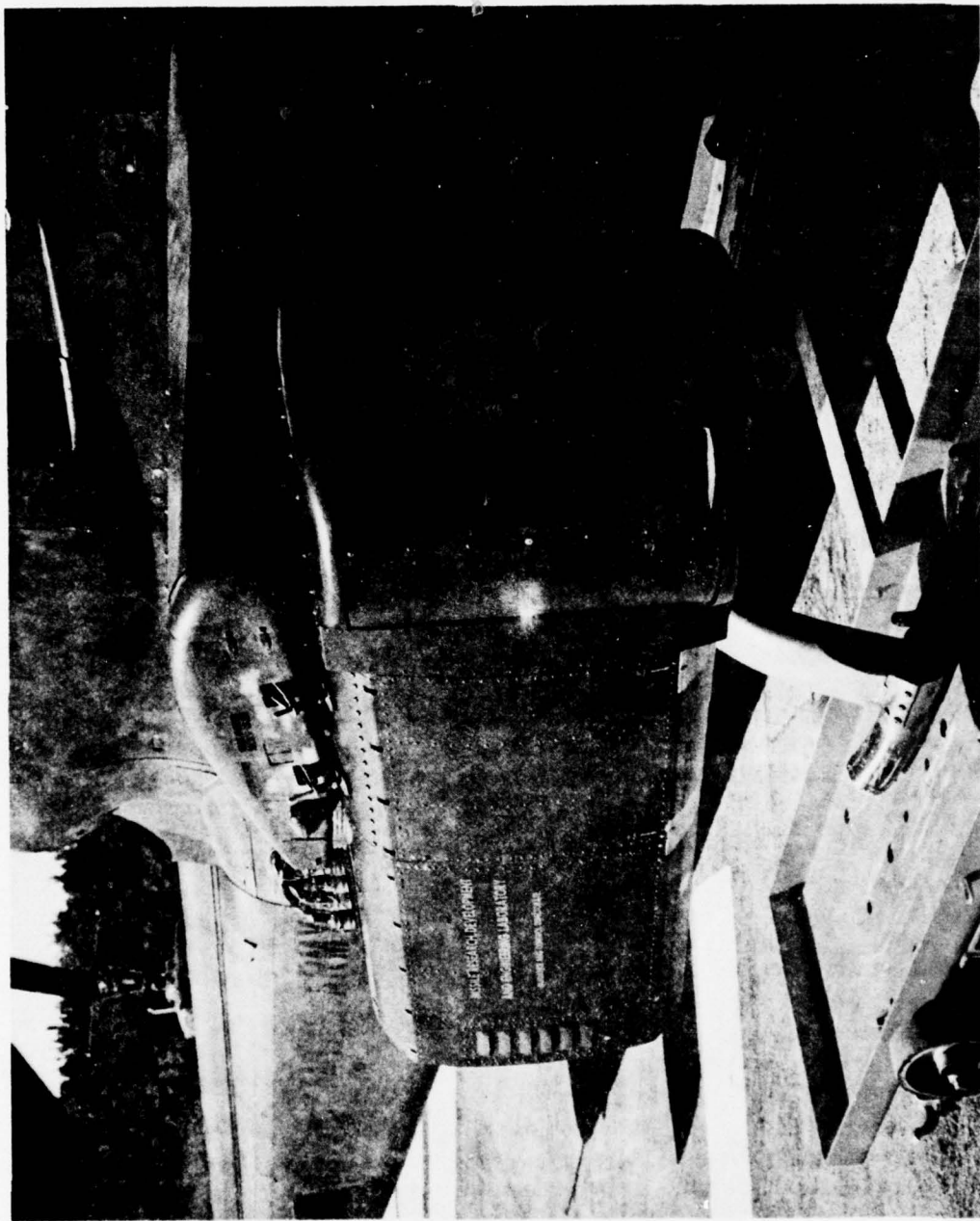

Figure 5. The SPAL pod mounted on the right outboard wing of an AH-1G COBRA.

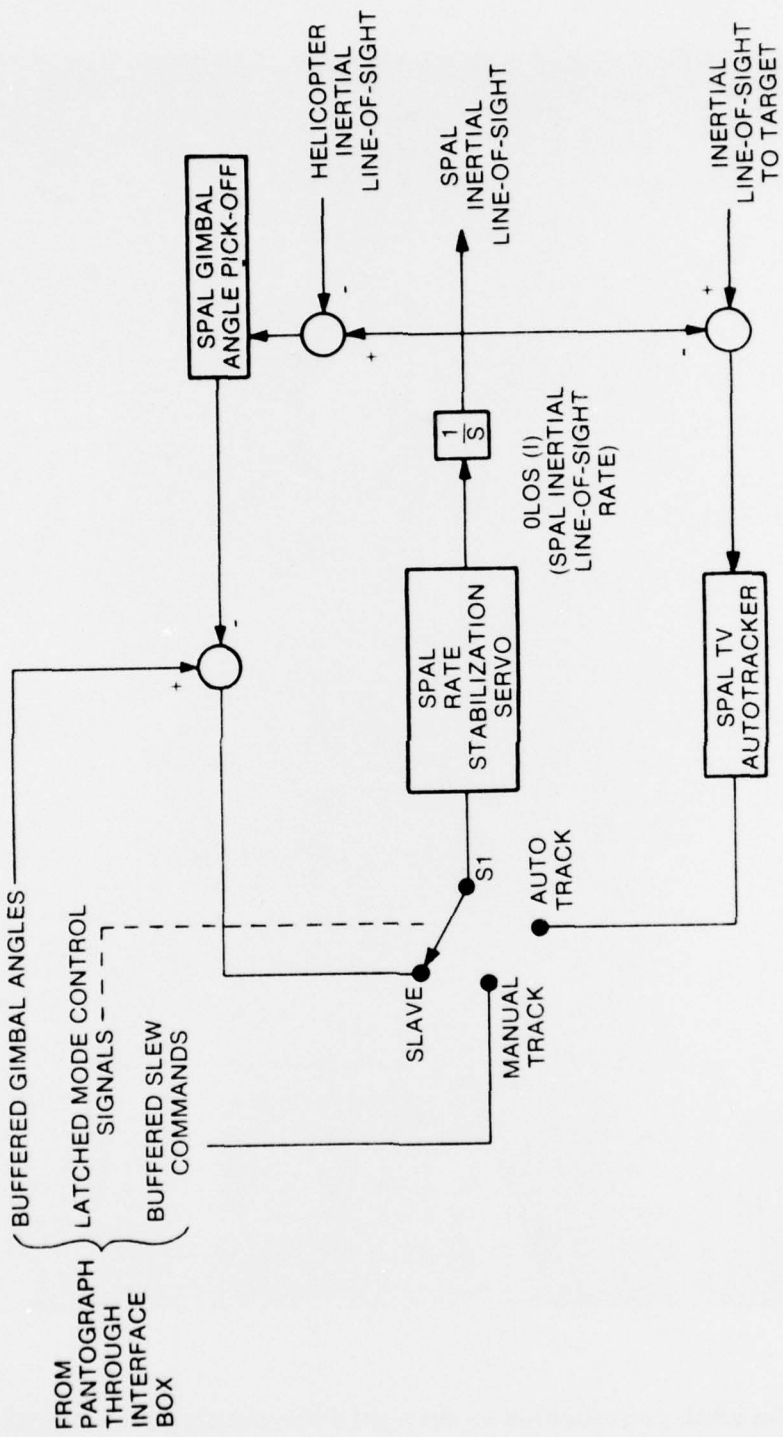

Figure 6. SPAL servo block diagram showing inputs from pantograph.

Unfortunately, the pantograph mounted display station was not designed to interface with the SPAL system. It was designed to support a simulation involving another airborne sighting system. Thus, although all of the mode control functions were available on the pantograph, the switch types were momentary contact, whereas the SPAL required continuous contact switching. To correct this incompatibility, an interface box was designed which contained the necessary logic and latches required to convert the momentary contact switching to continuous contact switching. The interface box also served to buffer the gimbal angle and slew command signals originating in the pantograph. A functional diagram of the total airborne system is given in *Figure 7*.

3. TEST DETAILS

The tests were run on clear days that allowed sighting of target areas at long as well as short ranges. Each gunner test subject was required to "engage" five targets using the following sequence of operation for each target:

- Prior to target engagement the gunner sets the following controls (see *Figure 3*):
 - Field-of-View switch to WFOV (wide field-of-view)
 - Mode switch to GNR (gunner). This sets S1 (see *Figure 7*) to the "slave" position, enabling the SPAL line-of-sight to follow the pantograph line-of-sight.
 - Breaklock mode switch as desired.
 - Auto track polarity as desired.
 - TV controls as desired.
- During target search, the gunner uses his naked eye to search for target signatures such as glints, dust clouds, etc.
- When a suspected target has been found, the gunner points the pantograph in the target direction and centers the target in the Newton ring reticle. Since the SPAL is slaved to the pantograph, the target area will appear in the TV display.

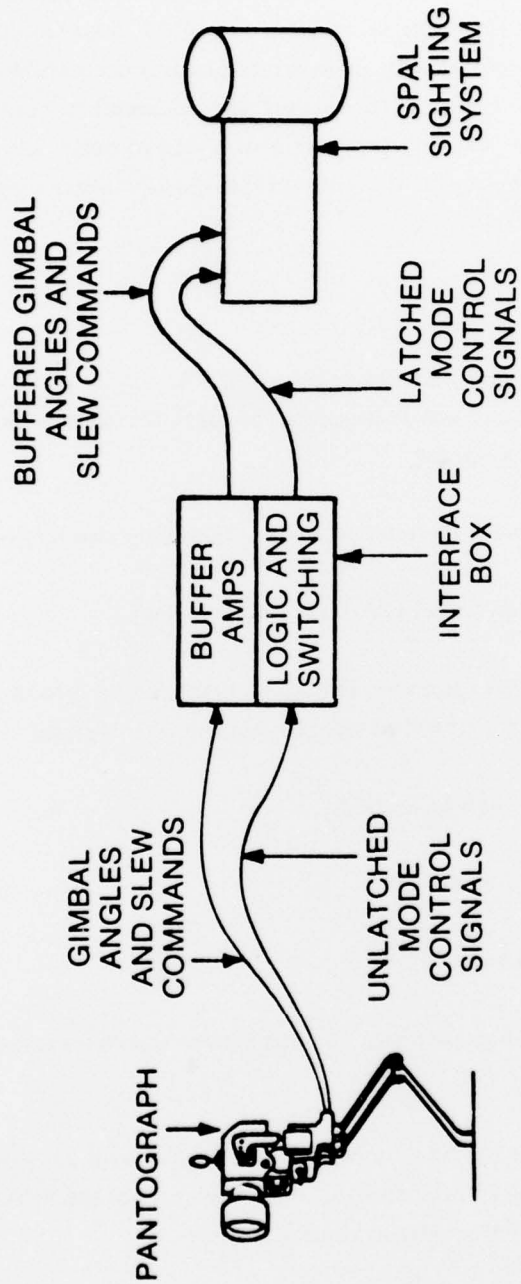

Figure 7. Functional diagram of the airborne sighting system.

- Using the mode switch the gunner switches S1 to the manual track position. This inertially stabilizes the SPAL and allows the gunner to search the target area using the slew command button.

- If more optical magnification is required, the gunner uses the field-of-view switch to switch to the SPAL narrow field-of-view.

- The gunner centers the target in the SPAL tracking gates using the slew command button.

- The gunner switches S1 to the autotrack position using the mode switch.

After the test flight each of the test subjects was required to answer a series of questions. The questions and gunner responses are given in *Table 2*.

TABLE 2. TEST DEBRIEFING QUESTIONS AND RESPONSES

QUESTIONS	RESPONSE				
	Gunner No. 1	Gunner No. 2	Gunner No. 3	Gunner No. 4	Gunner No. 5
1. Did the pantograph help in locating the target area as compared to manual searching?	Yes	Yes	Yes	Yes	Yes
2. Was the display subject to sun washout as compared to panel mounted monitors?	Yes	Yes	Yes	Yes	Yes
3. Would you prefer a pantograph display or a helmet sight and panel mounted display?	Helmet Sight	Panto- graph	*	Panto- graph	Panto- graph
4. Did helicopter motion cause problems with cuing and/or viewing?	Yes	Yes	Yes	Yes	Yes
5. Were the control switches located in logical, easily reached positions?	No	Yes	Yes	Yes	Yes
6. Were there any fatigue problems with holding the pantograph in a viewing position?	No	No	No	No	No

*This subject had never used a helmet sight.

4. CONCLUSIONS

Based on the data contained in *Table 2*, the following conclusions were drawn.

The pantograph did help the gunner find the target area more quickly than manual searching.

The display was subject to sun washout. However, it should be noted that the virtual image display in direct sunlight was almost as readable as a high quality, filtered, panel mounted CRT display in direct sunlight. If high brightness (>100 ft L) miniature CRT's become available, it is quite possible that a virtual image CRT display would become a significant improvement over a conventional filtered CRT display.

Most operators preferred the pantograph display rather than a helmet sight and panel mounted display. One particular shortcoming noted in the pantograph was that it could not be used as a cuing aid beyond about $\pm 30^\circ$ in azimuth from the helicopter centerline. The reason for this shortcoming is that the gunner can no longer see the reticle at angles greater than this.

Helicopter motion caused viewing and cuing problems. However, the same cuing problem exists with helmet sight systems; it is very difficult to place a reticle on target to the desired accuracy when in a moving helicopter.

Most operators thought the controls were easily reached and in logical positions.

No fatigue problems were noted.

DISTRIBUTION

	No. of Copies		No. of Copies
Defense Documentation Center Cameron Station Alexandria, VA 22314	12	DRSMI-LP, Mr. Voigt	1
IIT Research Institute ATTN: GACIAC 10 West 35th Street Chicago, IL 60616	1	DRDMI-T, Dr. Kobler -TBD -TI (Reference copy) -TI (Record Set)	1 3 1 1
Director US Army Materiel Systems Analysis Activity DRXSY-GS, Mr. D. Barnhart -MP, Mr. M. Winslow Aberdeen Proving Grounds Aberdeen, Maryland 21005	1 1	DRDMI-TGC	5