

AD-A070 369

BIOTECHNOLOGY INC FALLS CHURCH VA
REQUIREMENTS AND CRITERIA FOR IMPROVING READING COMPREHENSION 0--ETC(U)
NOV 74 T J POST, H E PRICE

F/6 5/2

N00024-74-C-5426

UNCLASSIFIED

/of|
AD
A070369

MI

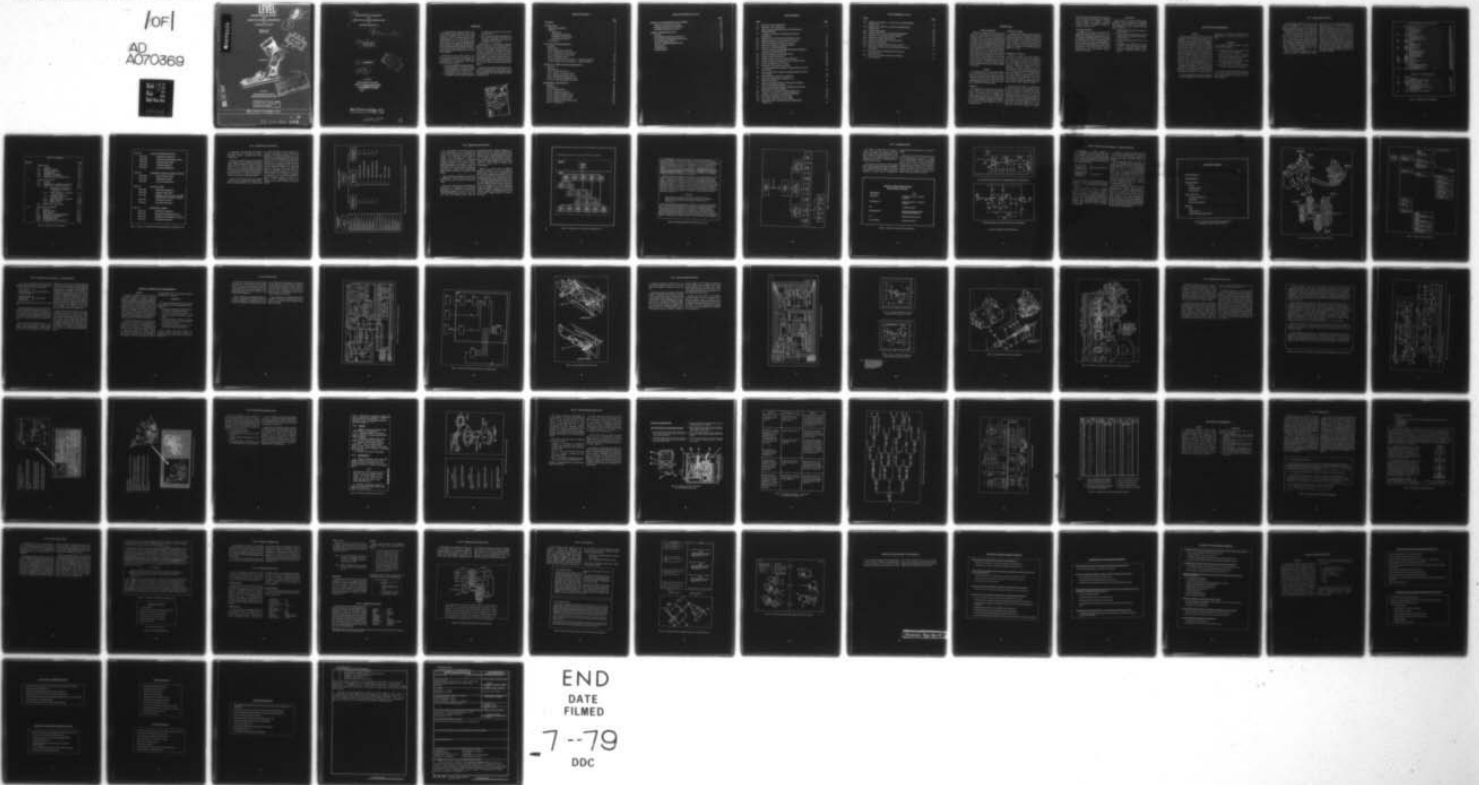

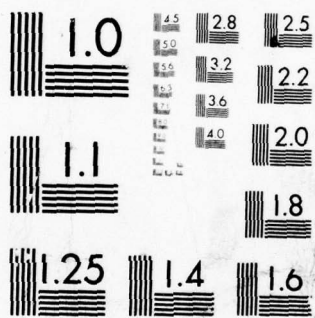

MICROCOPY RESOLUTION TEST CHART
 NATIONAL BUREAU OF STANDARDS-1963-A

LEVEL

REQUIREMENTS AND CRITERIA FOR IMPROVING READING COMPREHENSION OF TECHNICAL MANUALS

Theodore J. Post
Harold E. Price

ADA070369

~~SECRET~~
3

DDC
RECEIVED
JUN 26 1979
C

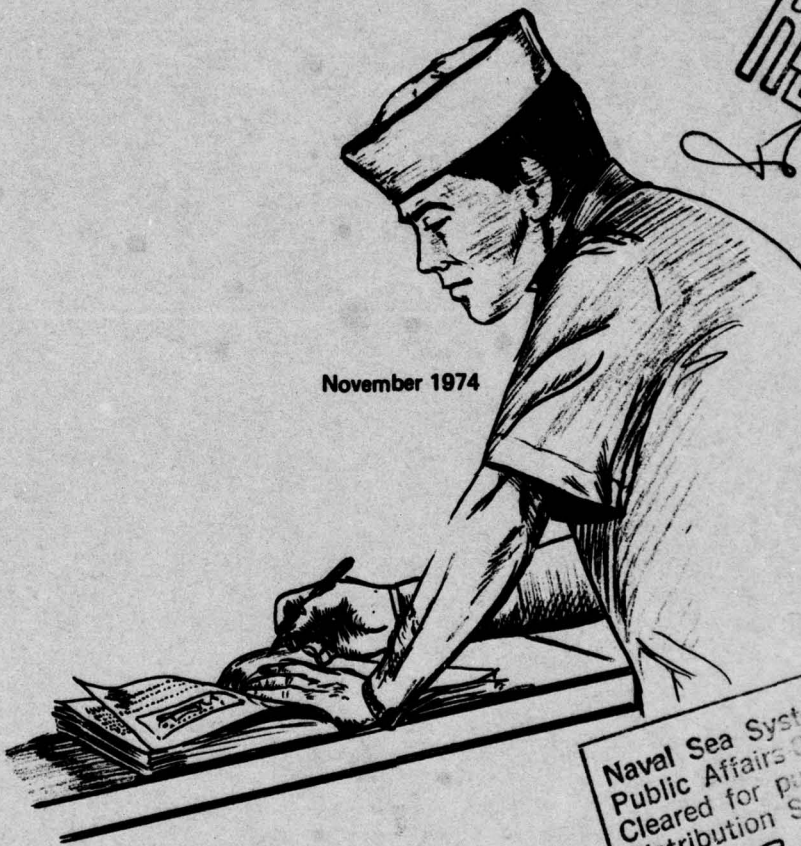

November 1974

6 FEB 1979

Naval Sea Systems Command
Public Affairs 0002
Cleared for public release.
Distribution Statement A
[Signature] #79-125

Prepared for

Naval Sea Systems Command
Technical Publications Branch, 0463

This document has been approved
for public release and sale; its
distribution is unlimited.

DDC FILE COPY

BioTechnology, Inc.

3027 ROSEMARY LANE • FALLS CHURCH, VIRGINIA

79 125

79 06 22 094

6

**REQUIREMENTS AND CRITERIA
FOR
IMPROVING READING COMPREHENSION
OF
TECHNICAL MANUALS .**

9

Final rept.,

10

by

Theodore J. Post
Harold E. Price

11

November 1974

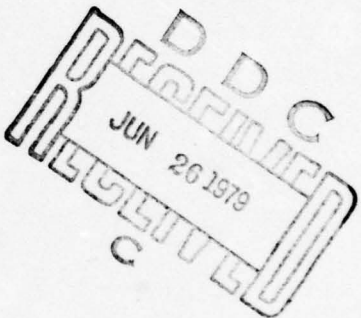

12

73p.

Prepared for

Naval Sea Systems Command
Technical Publications Branch, 0463
Contract **N00024-74-C-5426**

15

BioTechnology, Inc.
3027 ROSEMARY LANE • FALLS CHURCH, VIRGINIA

058050

LB

FOREWORD

An important finding of the Navy Enlisted Occupational Classification System (NEOCS) study was the existence of a significant "gap" between the reading comprehension level of technical manuals and the reading abilities of new Navy technicians. The Navy is "narrowing" this gap via a wide ranging research program including, for example, remedial training, new media techniques and simplified technical manuals. One part of this program deals specifically with the objective of improving the reading comprehension level of maintenance manuals. The project reported here is concerned with that objective.

This report, the first of three products to be delivered, presents requirements and criteria to be used by technical writers to improve the readability and comprehensibility of their manuscripts. The requirements and criteria presented here:

1. can be used to guide the original preparation of technical manuscripts or to determine whether an existing manual needs "rewriting" to bring its reading comprehension to an acceptable level;
2. go considerably beyond the traditional province of readability in that they address organization

and communication variables as well as nonprose presentations; and

3. must be tested to determine their impact on new Navy technicians with respect to performance of maintenance, understanding of the system, and acceptability of the new manual.

BioTechnology, Inc. is developing two companion products to this report. The first product specifies the impact these requirements and criteria will have on an existing maintenance manual. This impact will be shown in terms of a "book plan," a detailed outline of what this manual will look like when rewritten in accordance with the requirements and criteria presented here. The second product is a test plan for evaluating the rewritten manual. The test plan will be designed to point up the benefits which might accrue from a larger scale application of such a reading comprehension improvement program.

This study is being conducted for Naval Sea Systems Command, Code 0463. The technical monitor for the Navy is Mr. William Shihda; the principal investigators from BioTechnology, Inc. are Mr. Theodore J. Post and Mr. Harold E. Price.

| | |
|-------------------------------|----------------------|
| Accession For | |
| NTIS GRA&I | |
| DDC TAB | |
| Unannounced | |
| Justification <i>Per file</i> | |
| By <i>[Signature]</i> | |
| Distribution/ | |
| Availability Codes | |
| Dist | Avail and/or special |
| <i>A</i> | |

TABLE OF CONTENTS

| | <u>Page</u> |
|--|-------------|
| FORWORD | iii |
| INTRODUCTION | 1 |
| Background and Problem | 1 |
| Approach | 1 |
| Organization | 1 |
| Communication Adequacy | 1 |
| Readability of Prose Material | 1 |
| General Rewrite Practices | 2 |
| Test Procedures | 2 |
| ORGANIZATION REQUIREMENTS | 3 |
| Rationale | 3 |
| Requirements | 3 |
| Test 1. Maintainable Units Review | 4 |
| Test 2. Subordination of Units Review | 8 |
| Test 3. Repair Cycle Overview Check | 10 |
| Test 4. Consolidation Check | 14 |
| Test 5a. Package Content and Sequence – Organization Material | 16 |
| Test 5b. Package Content and Sequence – Technical Material | 20 |
| TECHNICAL COMMUNICATION REQUIREMENTS | 21 |
| Rationale | 21 |
| Requirements | 21 |
| Test 6. Job Relevance Check | 22 |
| Test 7. Materials Compression Review | 26 |
| Test 8. Equipment Description Review | 31 |
| Test 9. Narrative-Pictorial Balance Check | 36 |
| Test 10. Troubleshooting Procedures Need | 39 |
| READABILITY REQUIREMENTS | 45 |
| Rationale | 45 |
| Requirements | 45 |
| Test 11. Headings Review | 46 |
| Test 12. Topic Sentence Check | 48 |
| Test 13. Words Per Paragraph Count | 50 |
| Test 14. Words Per Sentence Count | 50 |
| Test 15. Syllables Per Word Count | 51 |
| Test 16. Equipment Nomenclature Check | 52 |
| Test 17. Layout Review | 53 |

TABLE OF CONTENTS (Continued)

| | <u>Page</u> |
|--|-------------|
| SUMMARY OF REQUIREMENTS AND CRITERIA | 57 |
| Organization Requirements Summary | 58 |
| Communication Requirements Summary | 59 |
| Readability Requirements Summary | 50 |
| GENERAL REWRITE PRACTICES | 61 |
| Rationale | 61 |
| Nontroubleshooting Procedures Practices | 62 |
| Proceduralized Troubleshooting Aids Practices | 62 |
| Functional Diagrams Practices | 63 |
| Schematic and Wiring Diagram Practices | 63 |
| Tables Practices | 64 |
| Graphs Practices | 64 |
| Pictorials Practices | 65 |

LIST OF FIGURES

| <u>Figure</u> | <u>Page</u> |
|---|-------------|
| 1-1 Illustration of Poor Organization | 5 |
| 1-2 Illustration of Poor Organization | 6 |
| 1-3 Table of Contents (partial) Showing Desired Emphasis on Maintainable Units | 7 |
| 2-1 Comparison of Hardware Packaging and Functional Organizations | 9 |
| 3-1 Sample Overview of a Portion of a Maintenance Cycle | 11 |
| 3-2 Illustration (partial) of a Poor Repair Cycle Overview | 12 |
| 3-3 Preferred Presentation of Repair Cycle Overview | 13 |
| 4-1 Illustration of Dispersion Throughout Manual | 14 |
| 4-2 Illustration of Masked Redundancy | 15 |
| 5-1 Table of Contents for Sample Maintainable Units Emphasizing Grouping of Troubleshooting Aids | 17 |
| 5-2 Sample of Equipment Terminology Pictorial | 18 |
| 5-3 Sample of Topdown Breakdown | 19 |
| 6-1 Sample (partial) of Excessive Detail in Schematics | 23 |
| 6-2 Sample of a Schematic Purged of Excessive Technical Detail | 24 |
| 6-3 Proper and Improper Levels of Detail | 25 |
| 7-1 Illustration of Information Compression | 27 |
| 7-2 Acceptable Information Compression (Approximately 3 elements per 1 sq inch) | 28 |
| 7-3 Excessive Information Compression (Approximately 5 elements per 6 sq inch) | 28 |
| 7-4 Sample Illustration Showing Acceptable Size | 29 |
| 7-5 Illustration of Information Compression in a Mechanical Situation | 30 |
| 8-1 (Sheet 1 of 2). Partial Narrative of Equipment Description Illustrating Compression Problem | 32 |
| 8-1 (Sheet 2 of 2). Schematic Portion of Equipment Description Illustrating Compression Problems | 33 |
| 8-2 Illustration of an "Itemized" Description (Electronic) | 34 |
| 8-3 Example of "Extremized" Description (Mechanical) | 35 |
| 9-1 Illustration of Imbalance in Favor of Prose | 37 |
| 9-2 Proper Balance Between Prose and Graphics | 38 |
| 10-1 Illustration of Step x Step Format for Troubleshooting Guidance Aid | 40 |

LIST OF FIGURES (Continued)

| <u>Figure</u> | <u>Page</u> |
|--|-------------|
| 10-2 Illustration of Symptom – Cause Format for Troubleshooting Guidance Aids | . 41 |
| 10-3 Illustration of “Logic Tree” Format for Troubleshooting Guidance Aids | . 42 |
| 10-4 Sample Wiring Diagram | . 43 |
| 10-5 Sample Guidance Format to Support Wiring Diagrams | . 44 |
| 11-1 Illustration of Text Placed in Wrong Paragraph | . 46 |
| 11-2 Illustration of Topical Discontinuity | . 47 |
| 12-1 Sample of Text Which Buries Important Topics | . 49 |
| 12-2 Preferred Tabular Format | . 49 |
| 16-1 Illustration of Equipment Nomenclature Pictorial | . 52 |
| 17-1 Illustration of Preferred and Less Desirable Presentations for Narrative | . 53 |
| 17-2 Illustration of Poor Contiguity Between Prose and Pictorial Material | . 54 |
| 17-3 Mixed Prose and Pictorial Presentation Showing Good Contiguity | . 55 |

INTRODUCTION

Background and Problem

Maintenance manuals are intended to provide technicians with the information they need to maintain the equipment assigned to their care. Unfortunately, many technicians do not use the manuals to support their job performance. The Navy has conducted research intended to identify manual problems that could be causing this poor utilization. Some candidate problems deal with the technical accuracy and completeness of manual information; other problems deal with certain of the manual's physical attributes such as size and weight; still others concern the currency of the information. The hope is that by solving problems such as these, more technicians will be inclined to use the manual more often. However, increasing the technician's willingness to use the manual will not improve technician performance *unless* the technicians are able to understand the guidance offered by the manuals. The material which follows is intended to help technical writers maximize the understandability of their manuals.

Approach

The problems which cloud manual understandability must be identified before any improvement can be attempted. Our approach assumes that the information which specifications prescribe for maintenance manuals is adequate but that its method of presentation causes understandability problems. The specific presentation aspects responsible for this difficulty follow.

Organization

The arrangement of content in conventional maintenance manuals may be logical but not particularly relevant to the technician's job. This disparity causes excessive search time, a major user complaint about technical manuals. In addition, once the user locates the several manual passages containing the relevant information, he must undertake a "gathering and collation" procedure which is especially difficult for users in the lower ability ranges.

Communication Adequacy

The adequacy with which the manual communicates technical information to the technician is a function of both the amount and type of information. Communication will be impaired when: (1) the information is too complex, (2) there is too much detail, or (3) too much of the information is irrelevant. Communication also suffers when the balance between graphics and prose is improper or the guidance for the technician is either too implicit or too explicit.

Readability of Prose Material

Technicians complain that reading manuals is difficult even when less than half of the manual's pages are continuous prose. For example, the readability of prose in representative manuals has been estimated at the 12th to 14th grade level. This means that users must possess the reading skill associated with 12th to 14th graders if reasonable comprehension is to be achieved (usually 75 percent correct on a comprehension test). Users possessing more limited reading skills can be expected to comprehend less of the included material. The results of testing representative maintenance technicians indicate that their reading abilities correspond to those of 9th grade students. This "gap" of three to five grade levels causes comprehension and attitude problems which contribute to the low utilization of manuals.

The material in this document is intended to help you identify and resolve technical manual problems of the types described above. Specifically, this document presents the requirements and criteria for presenting information which the user can access, read, and understand. The rationale underlying the requirements is presented and the criteria for meeting each requirement are developed in the form of tests. The tests address the characteristics your manual should have if it is not to suffer from the problems described above. Criteria within each test have been italicized for emphasis.

Corrective actions are also suggested when such actions are not obvious from the criteria statements. Finally, the tests are designed to be applied to completed maintenance manuals, either preliminary drafts (viz., in-process reviews) or operational manuals (viz., determine the need for rewrite).

General Rewrite Practices

In addition to the detailed tests described above, supplemental rewrite practices are included in a final section. These are general writing practices. The use of these practices should heighten the user's understanding and acceptance of the manual. These general practices are not intended to be used in deciding whether to rewrite an existing manual. This decision should be made on the basis of the principal requirements and criteria discussed above. Once a decision is made to rewrite a manual, however, these general practices should be included in the rewriting.

Test Procedures

Apply the three sets of tests in the following order: organization, technical communication, and readability. This sequence reflects an efficient process rather than relative importance. Descriptive material provided for each test set includes:

- a. Discussion of the purpose of each test and how it should be applied.
- b. Specific criteria the manuscript must meet and corrective actions to take when the tests uncover manual deficiencies.
- c. Examples illustrating good and bad use of the test criteria.
- d. A summary of the requirements and criteria intended for use after you have become familiar with the supporting discussions. These summaries are consolidated in the next to last section.

ORGANIZATION REQUIREMENTS

Rationale

Technicians expect maintenance manuals to provide information that will help them do their job. The information in the manuals should therefore be accessible via job-relevant terms, that is, the equipment units and the maintenance actions the technicians perform on each unit. The technician's need for information frequently includes more than one "maintainable unit" and more than one maintenance action. For example, to help isolate the cause of a malfunction, he may need information on progressively smaller maintainable units, often proceeding from the total system to the piece part level. The technician's information need invariably involves a succession of maintenance actions applied to progressively smaller units in the system hierarchy (e.g., consecutive troubleshooting actions concluded by replace, calibrate, and checkout actions). Accordingly, the organization of the manual should emphasize the hierarchy of maintainable units, the maintenance actions applicable to each maintainable unit, and the required sequences of maintenance actions.

The following material is a discussion and illustration of tests you should apply to your manual to determine

the adequacy of its organization. The discussions also suggest practices to correct any deficiencies you uncover.

Requirements

Four principal requirements apply to effective technical manual organization:

- The organization of the manual should be based on a hierarchy of maintainable units.
- Repair cycle overviews should be presented. These should be diagrammatic representations of the succession of maintenance actions.
- All information about a maintainable unit should be consolidated into a single package.
- The content, format, and sequence of information within a package should be standardized.

The following material expands these four requirements in terms of tests and criteria that will bring a poorly organized manual into compliance with a job-relevant organization.

Test 1. Maintainable Units Review

A manual organization preferred for its access and consistency consolidates in one location all information about a maintainable unit. Such a manual can be produced only when the primary basis for organization is maintainable units rather than types of information.

Review the table of contents and the manual itself to see whether the manual emphasizes maintainable units. The top level maintainable unit may be the entire system, a subsystem, or a major equipment end item. The successive breakdown into smaller maintainable units should be based primarily on functional considerations for isolating units during troubleshooting. The key step in correcting poor organizations is to *obtain or develop a "family tree" or topdown breakdown of the system in terms of maintainable units.*

Figures 1-1 and 1-2 show sample tables of content which do *not* emphasize maintainable units. Organiza-

tions like these tend to provide information about a maintainable unit in several different locations in a manual, especially where such items as principles of operation and troubleshooting are concerned. Also, the emphasis which the early sections give to hardware units vanishes as the manual begins to present job supporting procedures. Such organizations preclude easy access to key procedural information, e.g., Figure 1-1 "buries" 150 pages of critical troubleshooting schematics in sections 5-4 and 5-5. Similarly, Figure 1-2 shows how 13 pages of schematics are buried under the heading of "Troubleshooting." Figure 1-3 is an example of a partial table of contents organized around maintainable units. The pertinent document emphasizes troubleshooting information although nontroubleshooting materials are quite easily incorporated.

SECTION 4 PRINCIPLES OF OPERATION

| | | |
|------|--|------|
| 4-1 | Overall Functional Description | 4-1 |
| | a. General | 4-1 |
| | b. The Basic Process | 4-1 |
| | c. Symbol Formation | 4-1 |
| | d. Channel Function | 4-4 |
| | e. Video Output | 4-7 |
| 4-2 | Azimuth Section | 4-7 |
| | a. Differential Servo Unit | 4-8 |
| | b. Azimuth Servo Unit | 4-8 |
| | c. Azimuth Mark Generation | 4-8 |
| 4-3 | Servo Amplifier Circuit | 4-9 |
| 4-4 | Range Section | 4-10 |
| | a. Function | 4-10 |
| | b. Range Servo Unit | 4-10 |
| | c. Ramp Generation | 4-12 |
| 4-5 | Range Switching | 4-14 |
| 4-6 | Range Pulse Generation | 4-15 |
| | a. General | 4-15 |
| | b. Differential Comparator | 4-15 |
| | c. Two-Stage Amplifier | 4-15 |
| | d. Blocking Oscillator | 4-16 |
| | e. Output and Gating | 4-16 |
| 4-7 | Range Interval Generation | 4-16 |
| 4-8 | Symbol Forming | 4-18 |
| 4-9 | Video Mixing | 4-21 |
| 4-10 | Power Supply Circuits | 4-22 |
| 4-11 | Monitor Circuits | 4-22 |
| | a. General | 4-22 |
| | b. Video Range Monitoring | 4-24 |
| | c. Video Azimuth Monitoring | 4-24 |
| | d. Servo Monitoring | 4-28 |
| 4-12 | Power Supply Monitor Circuit | 4-29 |

SECTION 5 - TROUBLESHOOTING

| | | |
|-----|---|-----|
| 5-1 | General | 5-1 |
| | a. Procedure | 5-1 |
| | b. Printed Circuit Card Location | 5-1 |
| 5-2 | Test Equipment and Special Tools | 5-2 |
| 5-3 | Overall Troubleshooting | 5-3 |
| 5-4 | Functional Section Troubleshooting | 5-3 |
| | a. Preliminary Check | 5-3 |
| | b. Test Equipment and Special Tools | 5-5 |
| | c. Control Settings | 5-5 |
| | d. Procedure | 5-5 |
| 5-5 | Use of Voltage and Waveform Tables | 5-7 |

Figure 1-1. Illustration of Poor Organization.

TABLE OF CONTENTS

| <u>Section</u> | | <u>Page</u> |
|----------------|--|-------------|
| I | INTRODUCTION | 1-1 |
| | 1-1 GENERAL | 1-1 |
| | 1-3 SCOPE OF MANUAL | 1-1 |
| | 1-5 CHANGE DIRECTIVES | 1-1 |
| | 1-7 SSE REQUIRED | 1-4 |
| | 1-9 EQUIPMENT SUPPLIED | 1-4 |
| | 1-11 PHYSICAL DESCRIPTION | 1-4 |
| | 1-14 CAPABILITIES AND LIMITATIONS | 1-6 |
| II | SYSTEM DESCRIPTION | 2-1 |
| | 2-1 GENERAL | 2-1 |
| | 2-3 SYSTEM BLOCK DIAGRAM DISCUSSION | 2-1 |
| | 2-16 FUNCTIONAL CIRCUIT ANALYSIS | 2-6 |
| | 2-18 HORIZONTAL AND VERTICAL DEFLECTION CIRCUITS 1A1/1A2 | 2-6 |
| | 2-23 VIDEO PROCESSING CIRCUITS 1A5 AND 1A8 | 2-8 |
| | 2-29 PHOSPHOR PROTECTION CIRCUIT 1A12 | 2-12 |
| | 2-35 BITE GENERATION CIRCUITS | 2-13 |
| | 2-50 POWER SUPPLIES | 2-18 |
| | 2-54 CONTROL UNIT | 2-20 |
| | 2-56 SEQUENCE OF OPERATIONS | 2-21 |
| III | MAINTENANCE PROCEDURES | 3-1 |
| | 3-1 GENERAL | 3-1 |
| | 3-3 TEST EQUIPMENT | 3-1 |
| | 3-5 TEST POINTS | 3-1 |
| | 3-7 REMOVAL OF DEFECTIVE MODULES | 3-1 |
| | 3-13 PREVENTIVE MAINTENANCE | 3-2 |
| | 3-15 OPERATIONAL CHECK | 3-5 |
| | 3-20 TROUBLESHOOTING | 3-9 |
| | 3-26 ALIGNMENTS AND ADJUSTMENTS | 3-24 |

Figure 1-2. Illustration of Poor Organization.

| | |
|----------------|--|
| TSA 4-5 | TAKE OFF WARNING SYSTEM |
| TSA 4-5A | Preliminary Information |
| TSA 4-5B | Maintenance Dependency Chart |
| TSA 4-5C | Symptom-Cause Table |
| TSA 4-5D | Schematic Diagram |
| TSA 4-5E | Functional Description |
| TSA 4-6 | AUTOMATIC FLIGHT CONTROL SYSTEM |
| TSA 4-6A | Symptom-Cause Table |
| TSA 4-6B | Component Location |
| TSA 4-6C | Functional Description |
| TSA 5-0 | ENGINE SYSTEM |
| TSA 5-0A | Preliminary Information |
| TSA 5-0B | Symptom-Cause Table |
| TSA 5-0C | Vibration, N1, N2, EGT, and EPR Instrumentation Schematic Diagram |
| TSA 5-0D | Components Location |
| TSA 5-0E | Functional Description |
| TSA 5-1 | ENGINE OIL SYSTEM |
| TSA 5-1A | Preliminary Information |
| TSA 5-1B | Maintenance Dependency Chart |
| TSA 5-1C | Schematic and Components Location |
| TSA 5-1D | Functional Description |

Figure 1-3. Table of Contents (partial) Showing Desired Emphasis on Maintainable Units.

Test 2. Subordination of Units Review

A maintenance manual organized around maintainable units facilitates user access and also results in a subordination structure compatible with effective troubleshooting.

Maintenance manuals which ignore functional groupings of equipment in favor of hardware packages often contain lengthy troubleshooting sequences sometimes requiring as many as 100 to 125 steps. Procedural sequences of even one-third this length cause problems for technicians and technical writers. *Where possible, the ratio of superordinate to subordinate units should be in the order of 1 to 5, or 1 to 10.* Such a subordination results in relatively short troubleshooting sequences.

Figure 2-1 illustrates the different levels of subordination between a maintainable unit orientation and a hardware packaging orientation. The example is based

on a manual which did not contain a family tree or hierarchy of maintainable units. The equipment items appearing in the left-hand illustration are the first breakout of maintainable units under the total system. This means that overall troubleshooting must isolate a malfunction to one of 30 units, a process that could require two, three, or even four times that many steps. The illustration on the right-hand of Figure 2-1 shows an alternative hierarchical arrangement of maintainable units (less chassis and power supply units). This hierarchy of maintainable units has the advantage of initially isolating system malfunctions to one of three units rather than to one of 30 units. This arrangement also corresponds more closely with the "principles of operation" discussion appearing elsewhere in the manual, and the "troubleshooting schematics" in subsequent sections, both of which are functionally oriented.

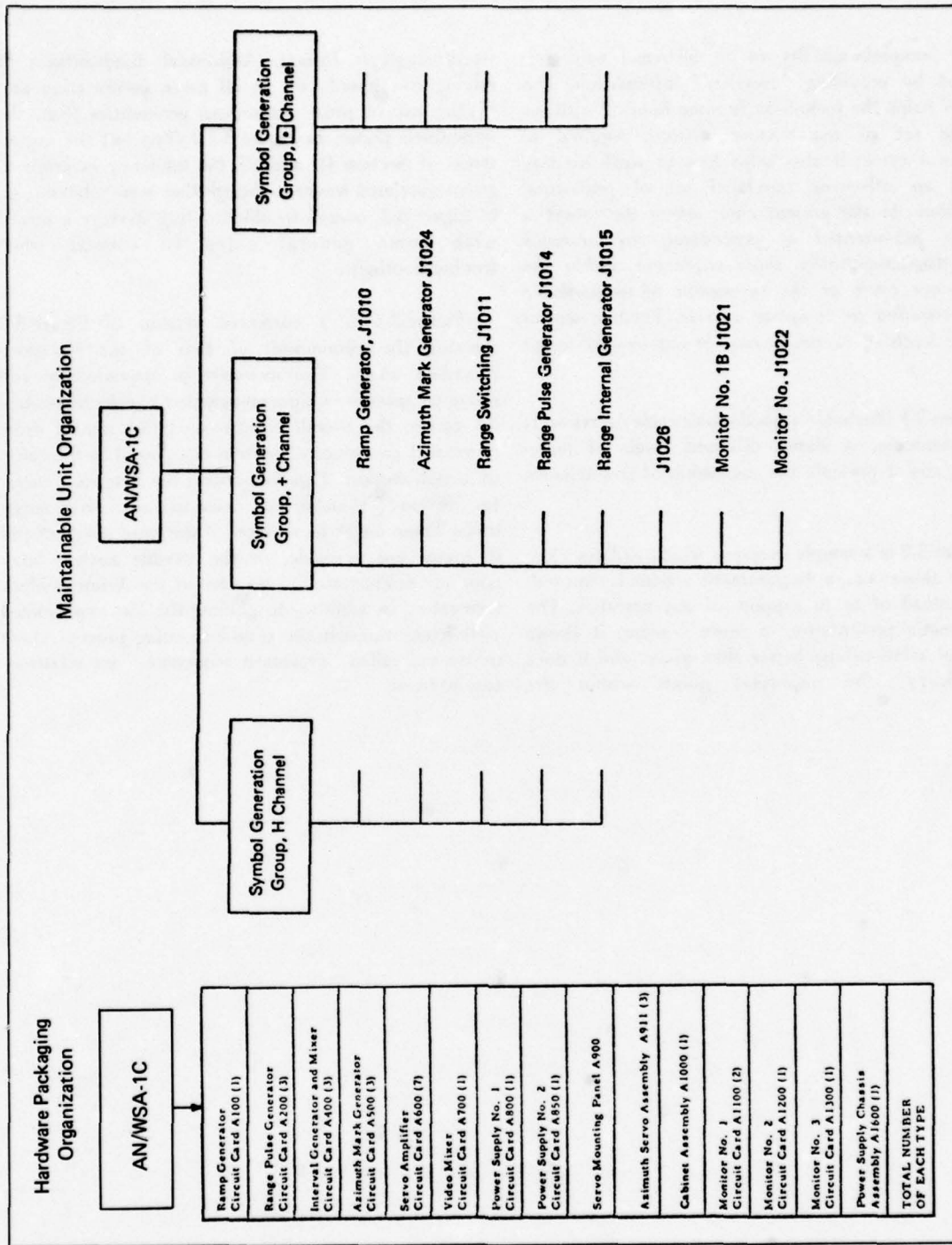

Figure 2-1. Comparison of Hardware Packaging and Functional Organizations.

Test 3. Repair Cycle Overview Check

The comprehensibility of all technical writing is enhanced by providing "overview" information. This overview helps the technician become familiar with the complete set of maintenance actions required to complete a cycle; it also helps him to work his way through an otherwise unrelated set of procedural descriptions. *In the present case, where the intent is primarily job-oriented or procedural, the overview should diagrammatically show sequences within the maintenance cycle or the succession of maintenance actions required to complete a cycle. Further, several different levels of overviews may be required for larger systems.*

Figure 3-1 illustrates a good repair cycle overview. It is diagrammatic, it shows different levels of maintenance, and it presents the succession of maintenance actions.

Figure 3-2 is a sample overview which violates a key principle above; viz., a diagrammatic version is required, either instead of or in support of any narrative. The diagrammatic presentation is more concise; it shows sequential relationships better than prose; and it does not "bury" the important points within the

word/paragraph format. Additional disadvantages of relying too heavily on an all prose presentation are: (1) the use of prose encourages generalities (e.g., the underlined phrase in Figure 3-2 calling out the importance of Section 4), and (2) the tendency in prose to group unrelated topics as though they were related (e.g., in Figure 3-2, overall troubleshooting strategy is mixed with some general rules to observe when troubleshooting).

Figure 3-3 is a corrected version of Figure 3-2 showing the elimination of two of the violations described above. The overview is diagrammatic and refers to specific equipment-oriented checks or repairs. As shown, the overall checks can indict one of three functional groupings of system equipment as the cause of a malfunction. Troubleshooting the Symbol Generator Section (□) isolates the cause to one of seven major units. These might be replaced if the need is urgent and if spares are available, or the trouble analysis may continue as illustrated in the case of the Azimuth Mark Generator. In addition to guiding the less experienced technicians through the troubleshooting process, these overviews, called "organized sequences," are relatively easy to learn.

Troubleshooting Data Coverage, AN/AQA-7 Subsystem

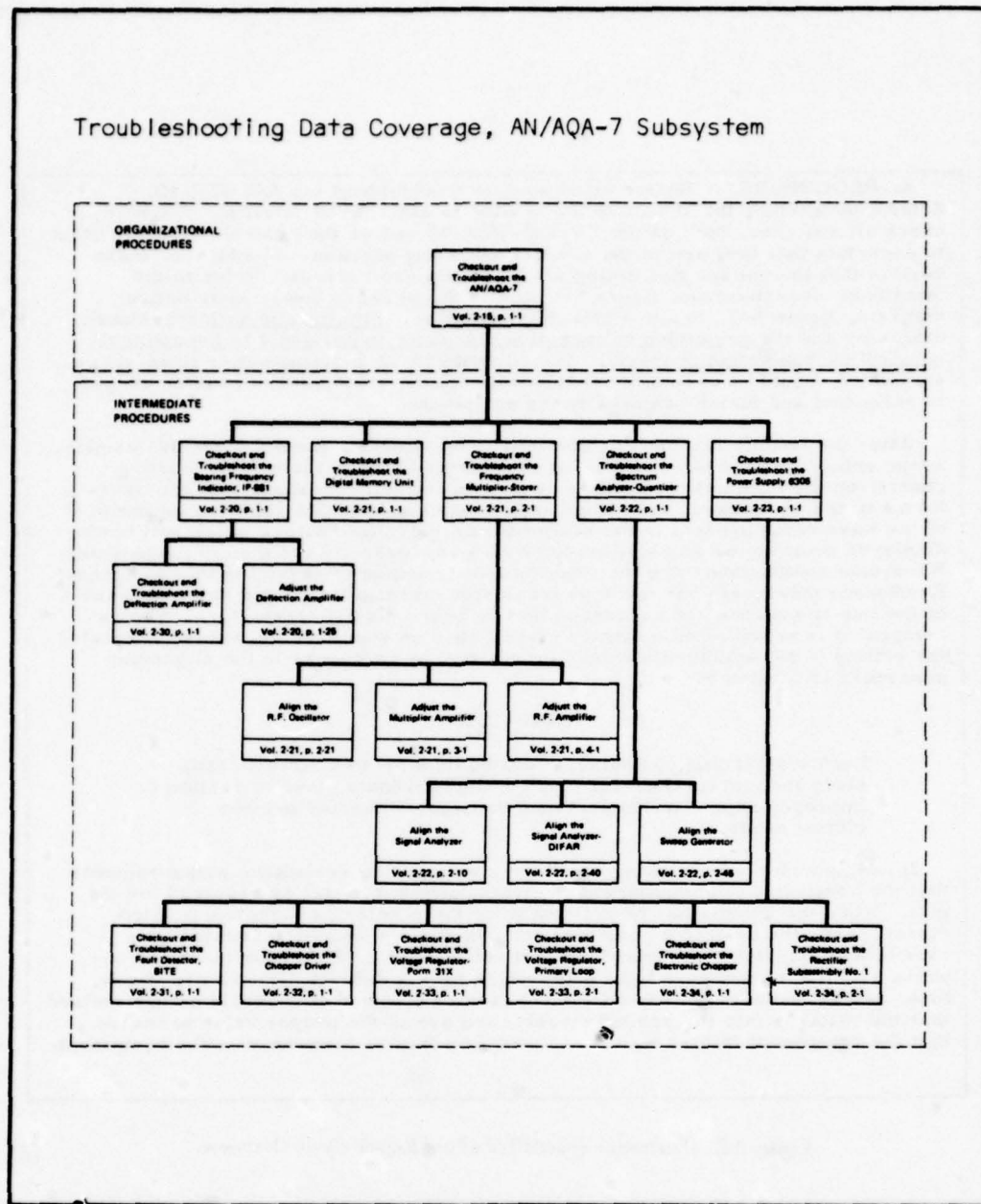

Figure 3-1. Sample Overview of a Portion of a Maintenance Cycle.

a. **PROCEDURE.** - Before attempting to troubleshoot the AN/WSA-1C, determine whether the source of the trouble is external or internal. Carefully check all switches, both on the CV-933/WSA-1C and on the control-indicator units to ascertain that they are in the correct operating position. In addition, make certain that the voltage and timing for all inputs are correct. Refer to the functional block diagram, figure 5-1, and to the primary power distribution diagram, figure 5-2, to aid in this determination. Familiarity with these basic diagrams and the principles of operation discussed in Section 4 is essential to service the equipment properly. The advisability of applying power to defective equipment should be carefully considered from the standpoint of causing danger to personnel and further damage to the equipment.

After the trouble has been determined to be internal, the AN/USM-105 oscilloscope should be used to compare the waveforms given in the troubleshooting charts, on the schematic diagrams, and in the waveform charts with the waveforms in the equipment. It is important to use the AN/USM-105 because many of the waveforms present in the equipment are very fast pulses which will not be displayed properly on an oscilloscope with a bandpass of less than 15 megacycles. Waveform comparisons are the most effective method of servicing this equipment. Resistance measurements made on transistor circuits have little value because of the low-impedance and current-sensitive properties of transistors. When a component is replaced on a printed circuit card on which an adjustment is located, the setting of the adjustment should be verified by reference to the alignment procedure in Section 6.

CAUTION

Before replacing components located on a printed circuit card, study the instructions for printed circuit repair given in Section 6. Improper repair techniques may damage or destroy printed circuit cards.

It is important when making waveform, voltage, or resistance measurements that the controls on the equipment and test equipment be set as required for the test. When the trouble has been found to be the result of a defective printed circuit card, the defective component or components should be located by a careful analysis using the waveform and voltage data. This equipment has no parts with the exception of light bulbs which have a definite limited life: therefore, before replacing a printed circuit card or component it should be determined that the voltages into the printed circuit card are of the proper value to insure that the component failure was not caused by a failure elsewhere in the equipment.

Figure 3-2. Illustration (partial) of a Poor Repair Cycle Overview.

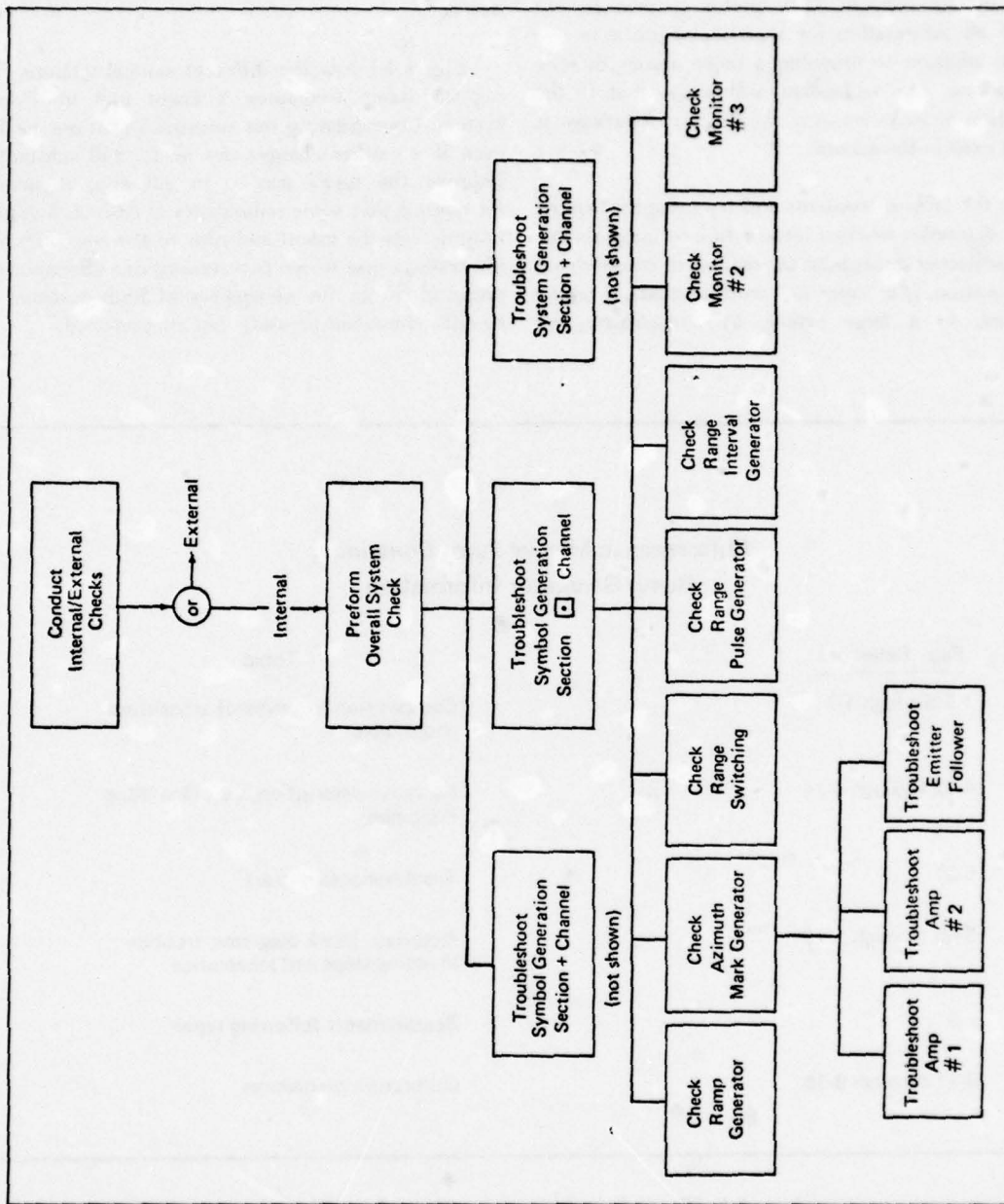

Figure 3-3. Preferred Presentation of Repair Cycle Overview.

Test 4. Consolidation Check

Users object to being referred from section to section of the manual. They prefer an arrangement whereby all information for a particular job is in one place. In addition to providing a single source, thereby easing access, the technician will know that if the information he seeks is not in the designated package, it does not exist in the manual.

Scan the table of contents and try using the manual itself to determine whether information on maintainable units is scattered throughout the manual or consolidated in one location. *If a "refer to" problem exists, it can be eliminated, to a large extent, by consolidating all*

information about a maintainable unit in one location or package.

Figure 4-1 lists the different manual sections covering the Ramp Generator, a major unit of a sample system. Consolidating this information in one package, even if no other changes are made, will substantially improve the user's access. In addition, it must be recognized that some redundancy is desired. Masking it only defeats the intent and adds to the cost. Figure 4-2 illustrates a case where two versions of a schematic were prepared. From the viewpoints of both cost and user benefit, redundant presentations are preferred.

| <u>Page Reference</u> | <u>Topic</u> |
|-----------------------|--|
| 1-5 through 1-7 | Composition in terms of transistors and diodes |
| 4-12 through 4-14 | Narrative description, viz., Operating Principles |
| 5-31 | Troubleshooting chart |
| 5-65 through 5-76 | Pictorials, block diagrams, troubleshooting steps and schematics |
| 6-3 | Requirements following repair |
| 6-11 through 6-15 | Calibration procedures |

Figure 4-1. Illustration of Dispersion Throughout Manual.

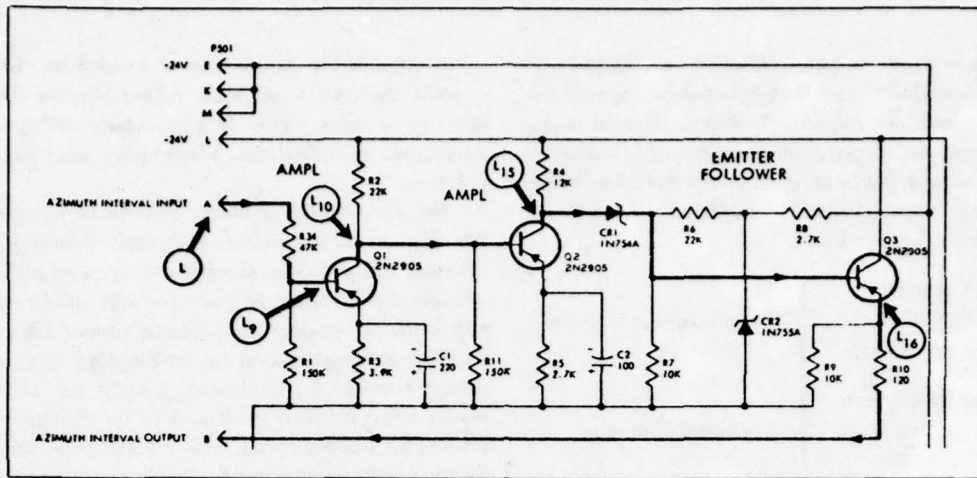

Portion of Schematic Appearing in the Troubleshooting Section of a Sample Manual

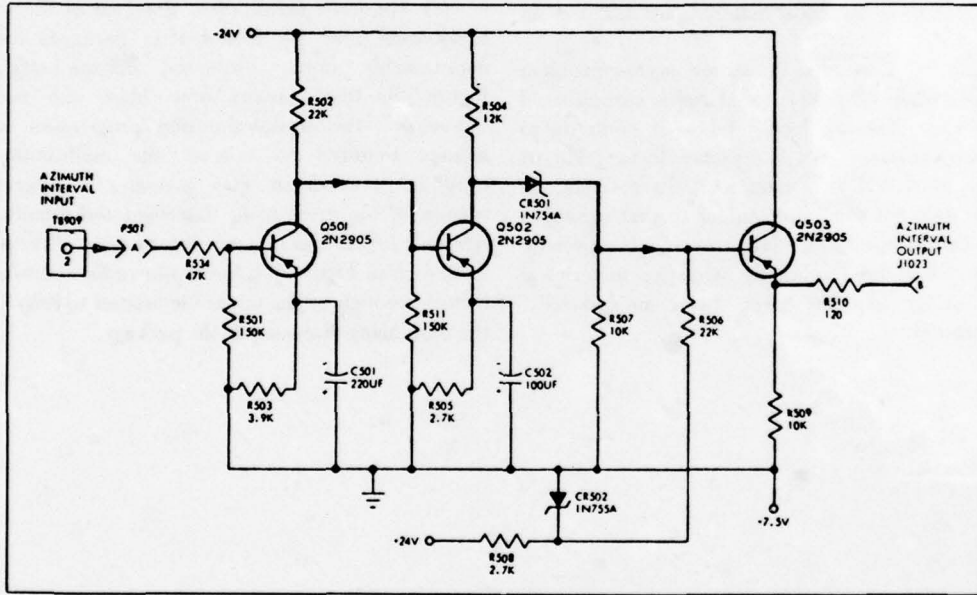

Schematic Appearing in the "Principles" Section of a Sample Manual

Figure 4-2. Illustration of Masked Redundancy.

Test 5a. Package Content and Sequence — Organization Material

Standardization is an effective technique for enhancing readability and comprehension. Where maintenance manuals are concerned, standardization means the same content, format, and sequence of information within a package. To be acceptable, the materials within each package should include items listed below in the order in which they are listed.

| | | |
|-----------------------|---|-------------------------|
| Table of Contents | } | Organizational Material |
| Terminology Picture | | |
| Topdown Breakdown | | |
| Operating Description | } | Technical Material |
| Troubleshooting | | |
| Repair Procedures | | |

Test 5a, discussed below, treats the first three items referred to as organizational material. The last three items, referred to as technical material, are discussed in Test 5b.

(a) *Table of Contents.* A minor access problem remains even when all relevant material is consolidated in one package. Use a "local" table of contents to alleviate this problem. An acceptable local table of contents is presented in Figure 5-1. Alternatively, an overview or data coverage plan similar to that shown in Figure 3-3 can be used. This latter option is especially appropriate when predominantly narrative material is presented under separate cover from procedurally-oriented material.

A local table of contents is needed to show what content material is available rather than to direct the user to a page. This is particularly important for microform presentations where page scanning is not practical.

(b) *Terminology Picture.* Poor or lazy readers tend to skip over unfamiliar technical terminology. To alleviate this problem, *provide one or more pictorials to introduce the reader to main features of the maintainable unit.* Of course, the pictorial cannot eliminate all reading problems caused by terminology (e.g., pulsing, gating, coupled to, nonlinearity, etc.), but at least the reader will have seen the names of the equipment items he will be reading about. This content item also aids in locating and recognizing the items during maintenance. A sample terminology pictorial is shown in Figure 5-2. Note the "contextual" locator picture with the accompanying blowup, and cutaway.

(c) *Topdown Breakdown.* Portions of the topdown breakdown may be included in packages for larger maintainable units. Presented diagrammatically in Figure 5-3, this content item helps the technician "visualize" the troubleshooting progression and the actions required to correct the malfunction. *The topdown breakdown also provides a diagrammatic version of the items to be described and establishes the referents for the maintenance information of the package.* As shown in Figure 5-3, the topdown breakdown should include enough of the upper hierarchies to help "locate" the item being discussed in the package.

Azimuth Mark Generator

Page

| | |
|---|--|
| Terminology Pictorial | |
| Topdown Breakdown | |
| Operating Description | |
| Function | |
| Two-Stage Amplifier | |
| Emitter Follower | |
| Trouble Analysis Aids | |
| Verification of Malfunction | |
| Power Checks | |
| Piece Part Isolation Checks | |
| References | |
| Repair | |
| Adjust/Alignment | |
| Standard Operating Procedures (SOP) | |

Figure 5-1. Table of Contents for Sample Maintainable Unit
Emphasizing Grouping of Troubleshooting Aids.

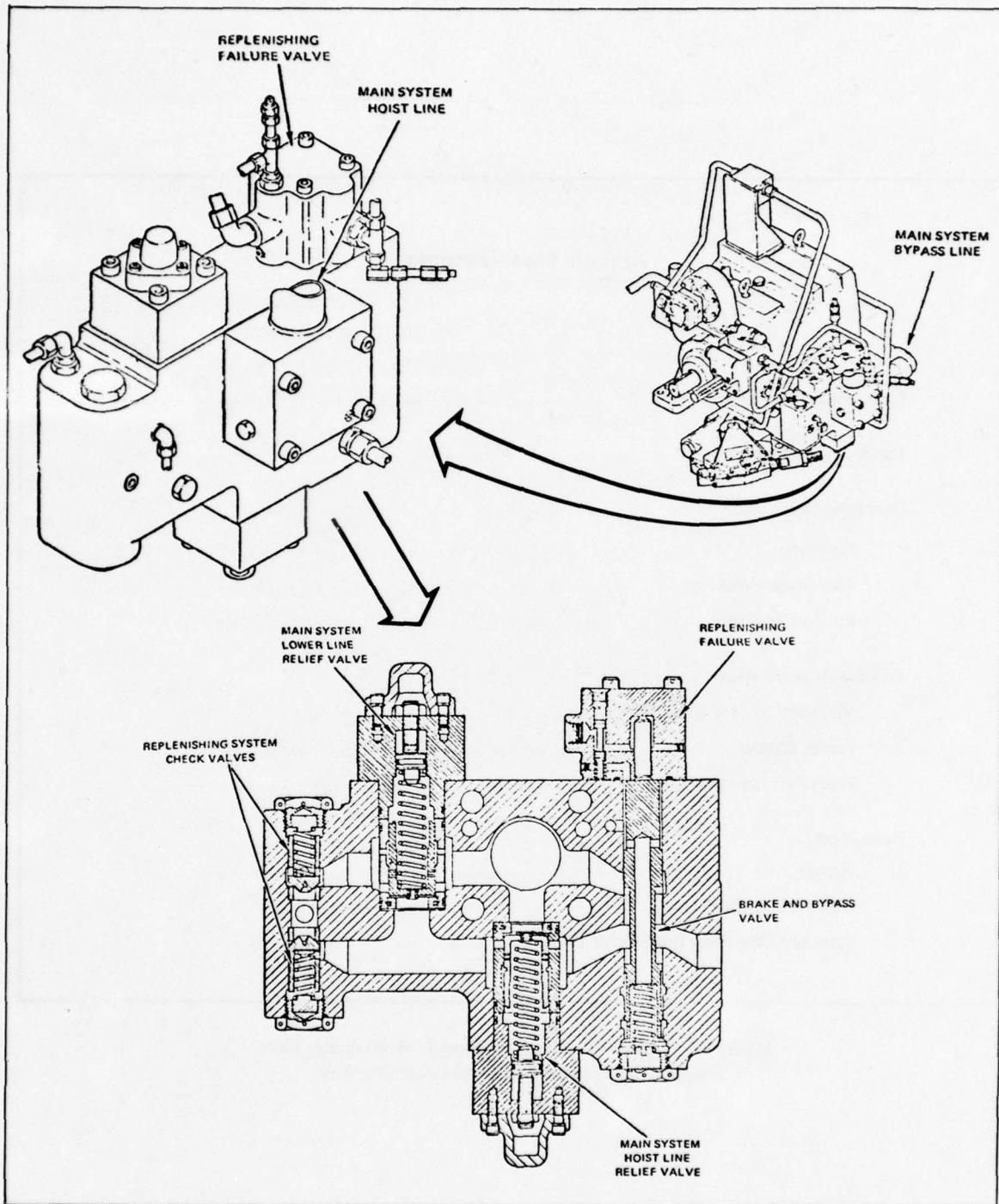

Figure 5-2. Sample of Equipment Terminology Pictorial.

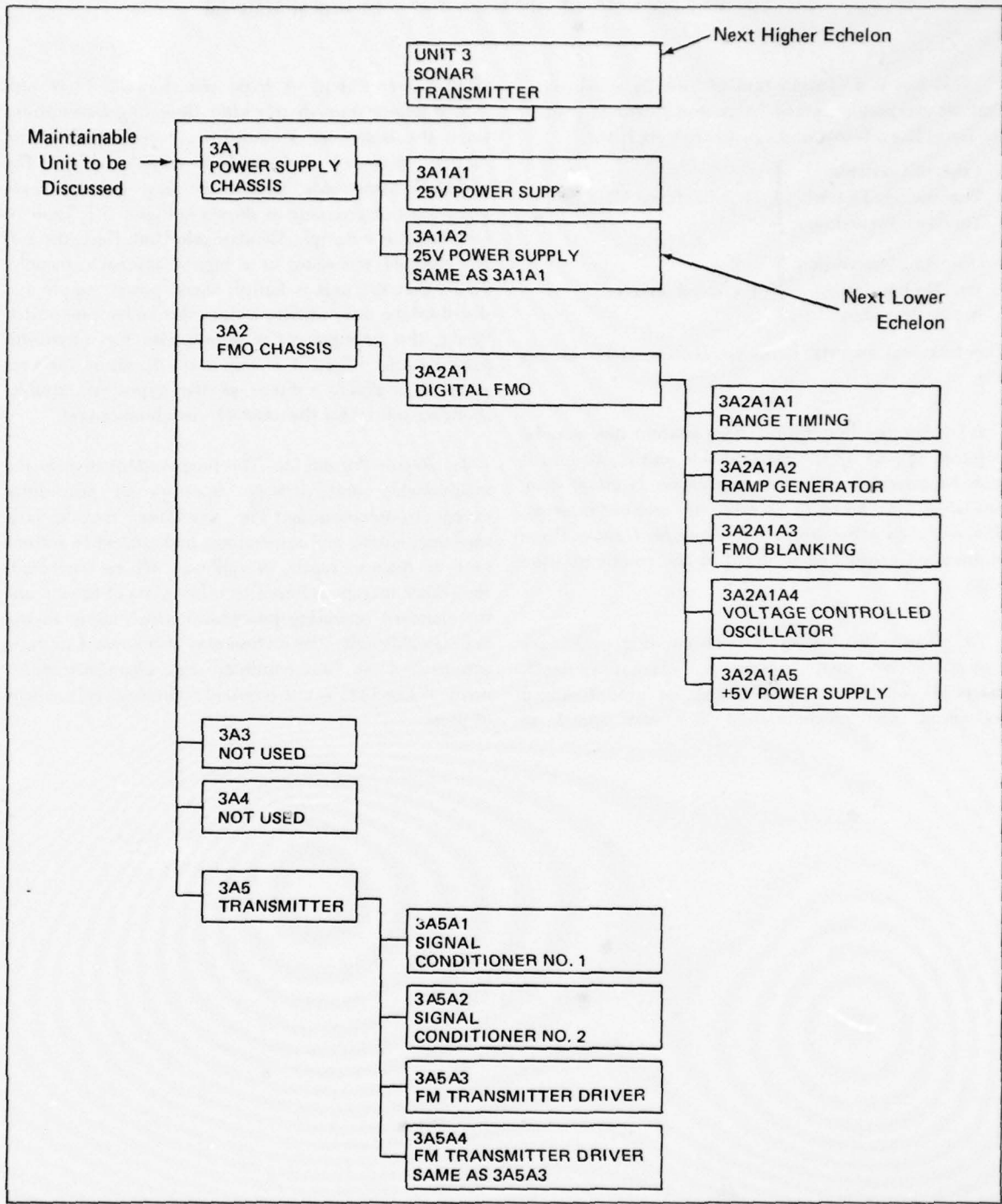

Figure 5-3. Sample of Topdown Breakdown.

Test 5b. Package Content and Sequence – Technical Material

This test is a continuation of Test 5a which states that an acceptable package of materials should contain the items listed below in the order they are listed.

| | | |
|-----------------------|---|-------------------------|
| Table of Contents | } | Organizational Material |
| Terminology Picture | | |
| Topdown Breakdown | | |
| Operating Description | } | Technical Material |
| Troubleshooting | | |
| Repair Procedures | | |

The technical material items are accounted for in this test.

(a) *Operating Description.* This content item may be required as part of the maintainable unit package or it may be provided under separate cover. *In either case, care should be taken to present only relevant information, and then in the most comprehensible format.* These matters are considered in detail in the communication tests.

(b) *Troubleshooting.* Troubleshooting aids are required. They may appear as schematics, block diagrams, functional flow diagrams, or proceduralized sequences. The proceduralized aids may appear in

tabular, step x step, or logic tree format. *These aids should appear immediately after Operating Descriptions* since the latter are intended to provide background material necessary or desirable in trouble analysis. *The troubleshooting aids themselves may warrant some sequencing or grouping* as shown in Figure 5-1, Table of Contents for a Sample Maintainable Unit. Here, the aids are grouped according to a logical approach; namely, verify that the unit is faulty; check power supply and distribution; and, finally, isolate the faulty piece part. Again, this arrangement is appropriate for microform presentations where it is important to show the user what is available – three specific types of troubleshooting aids rather than merely “troubleshooting.”

(c) *Repair Procedures.* The final content item in the maintainable unit package describes all procedures except troubleshooting. The procedures may include servicing, checks and inspections, and corrective actions such as replace, repair, or calibrate. Where warranted, the reader may be referred to other parts of the manual for standard operating procedures which apply to the maintainable unit. This section may also be used to show actions that are “not required,” e.g., alignment/adjustment of this PCC is not required following replacement of parts.

TECHNICAL COMMUNICATION REQUIREMENTS

Rationale

The purpose of maintenance manuals is to communicate technical information in order to enhance the performance capability of maintenance technicians. Manuals accomplish this by describing the equipment to be maintained and the procedures involved in performing the maintenance. These communications are often inadequate because of information "overload." This problem occurs when the writer includes more information than the technician needs to perform the maintenance action. In other cases, overload occurs when too much information is included in a given image area resulting in a cluttered appearance. The tests to follow will discuss both the *excess* and *clutter* inadequacies.

Communication problems also occur when presentations include the wrong type of information. These inadequacies can result from misplacing emphasis on graphic or prose materials, e.g., not including enough pictorials. A second communication problem with type of information concerns the tradeoff between: (1) telling the technician what to do and (2) letting him figure out the best procedure based on a description of the equipment at hand. Too much emphasis on either of

these approaches results in communications considered inadequate by some technicians.

Requirements

The technical communication adequacy of manuals will be enhanced when the following requirements are emphasized:

- Presentations should include only that information required to support job performance.
- The amount of information included in the image area should be controlled to prevent clutter.
- The balance between narrative and pictorial should favor pictorials to minimize procedural errors and performance time.
- Troubleshooting materials should include a mix of descriptive and procedural information.

These tests apply to all system description and procedural materials. Collect these materials and evaluate their communication adequacy according to the following tests.

Test 6. Job Relevance Check

Presentations which combine irrelevant and relevant information are considered difficult. This condition occurs most often in schematics and pictorials which include more detail than the technicians need. Review the materials in your maintenance packages for job relevance. *Information which is not relevant to the job at hand should be eliminated.*

Figure 6-1 illustrates excess detail in schematics. The piece parts of this schematic are a faithful representation of system composition and operation. However, this schematic was included in an organizational level main-

tenance manual where replacement of piece parts was not authorized. Thus, the detail might be meaningful to the more sophisticated technicians, but the majority of technicians find it difficult to interpret. Figure 6-2 shows the result of eliminating excess detail from a similar schematic. This block diagram is much easier to use than its Figure 6-1 counterpart.

Figure 6-3 illustrates excess and appropriate amounts of detail in a line drawing, considering that the job at hand is the removal of the pin and hinge of the mechanical assembly.

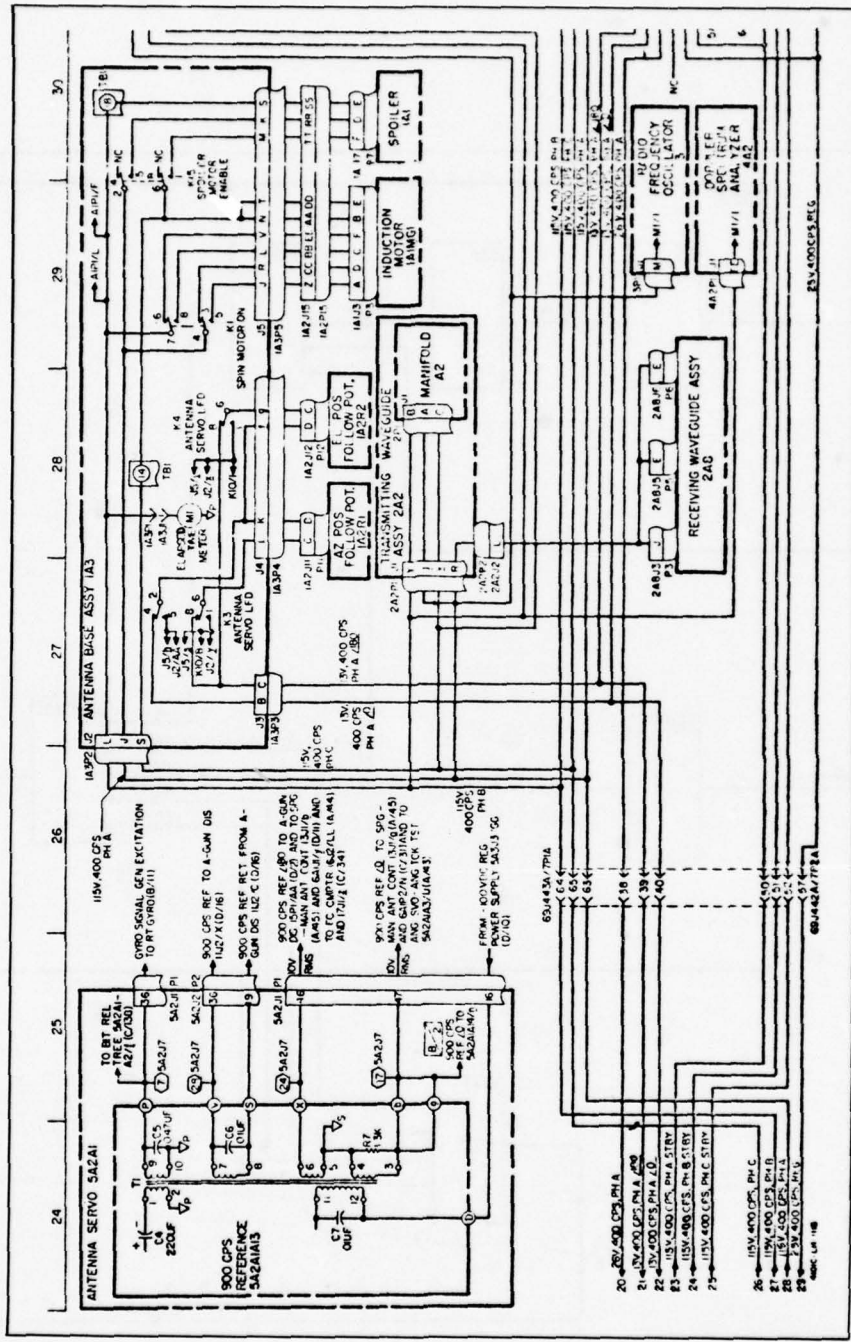

Figure 6-1. Sample (partial) of Excessive Detail in Schematics.

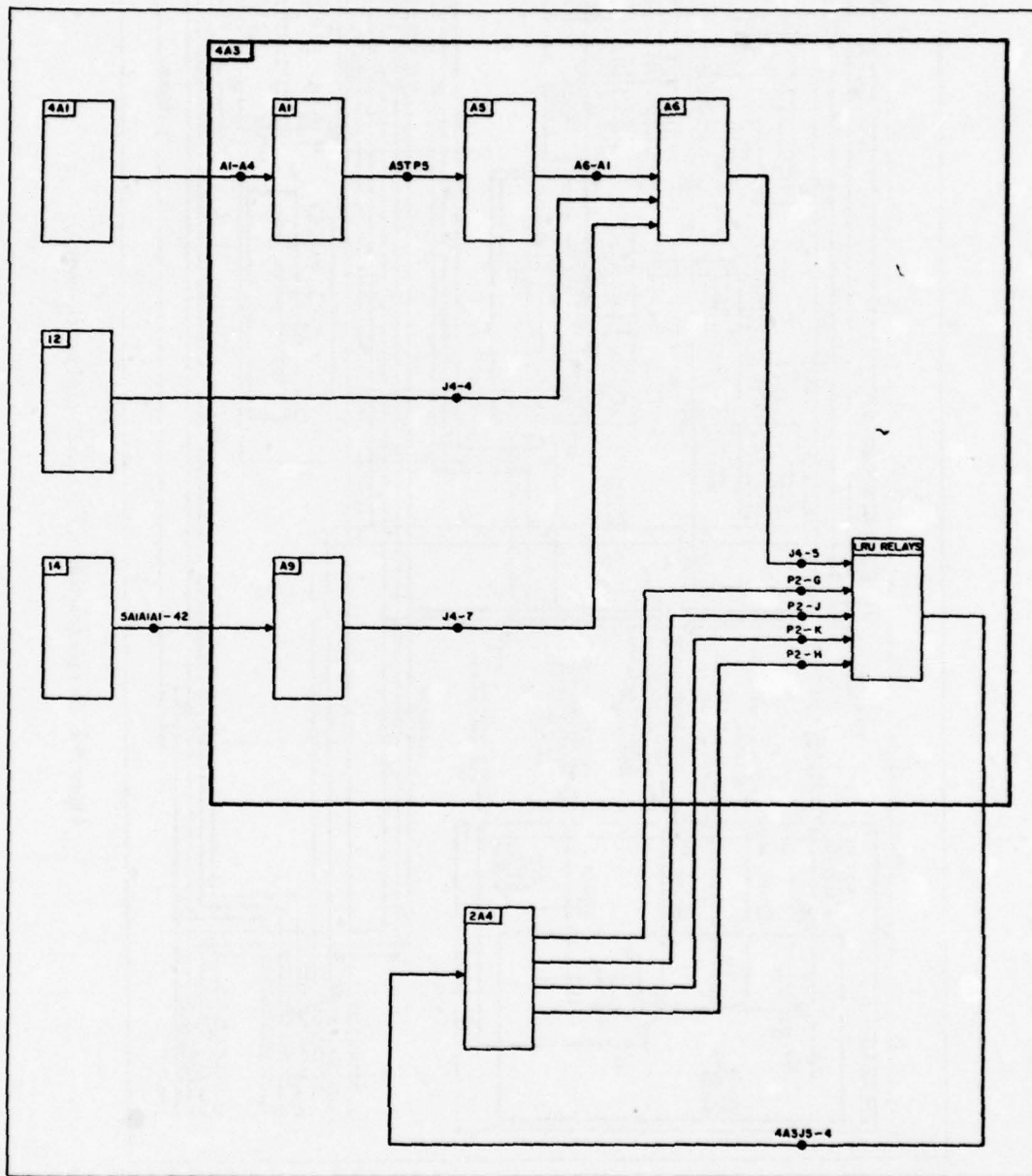

Figure 6-2. Sample of a Schematic Purged of Excessive Technical Detail.

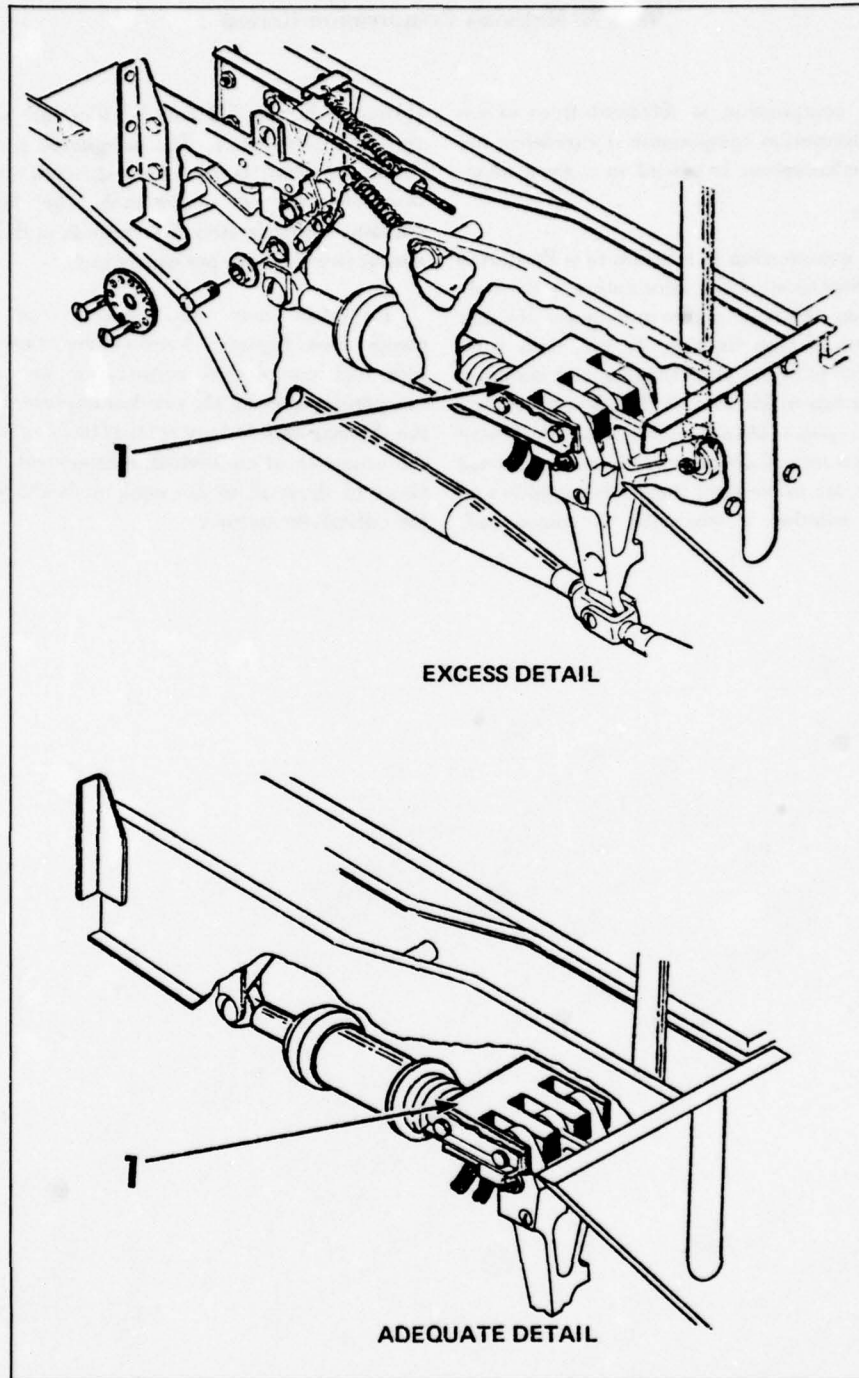

Figure 6-3. Proper and Improper Levels of Detail.

Test 7. Materials Compression Review

Information compression is different from excess detail in that information compression occurs when too much relevant information is placed in a given image area.

Information compression in schematics is illustrated in Figure 7-1. Dispersion of the information is the only solution, but doing this may require more pages, thereby creating problems of page flipping. As yet, there is no good compromise between page flipping and compression. However, a reasonable rule of thumb is as follows: "Where multiple pages already exist, disperse. Where compression exists on a single page (no foldouts), do not disperse." There are no verified standards to guide you in determining whether a schematic is compressed.

However, Figures 7-2 and 7-3 illustrate acceptable and cluttered schematics. *The acceptable version contains about 20 elements per 2.5- x 2.5-inch area, or about three elements per square inch.* The cluttered version contains approximately 30 elements in the same area, or almost five elements per square inch.

Pictorials may also suffer from information compression. Figures 7-4 and 7-5 are examples of acceptable and compressed versions of pictorials. *For an acceptable pictorial, the smallest important dimension of the drawing should be at least 1/10 of an inch.* Note also the sequence of contextual, enlargement, and exploded views to show all of the equipment and yet emphasize the critical dimensions.

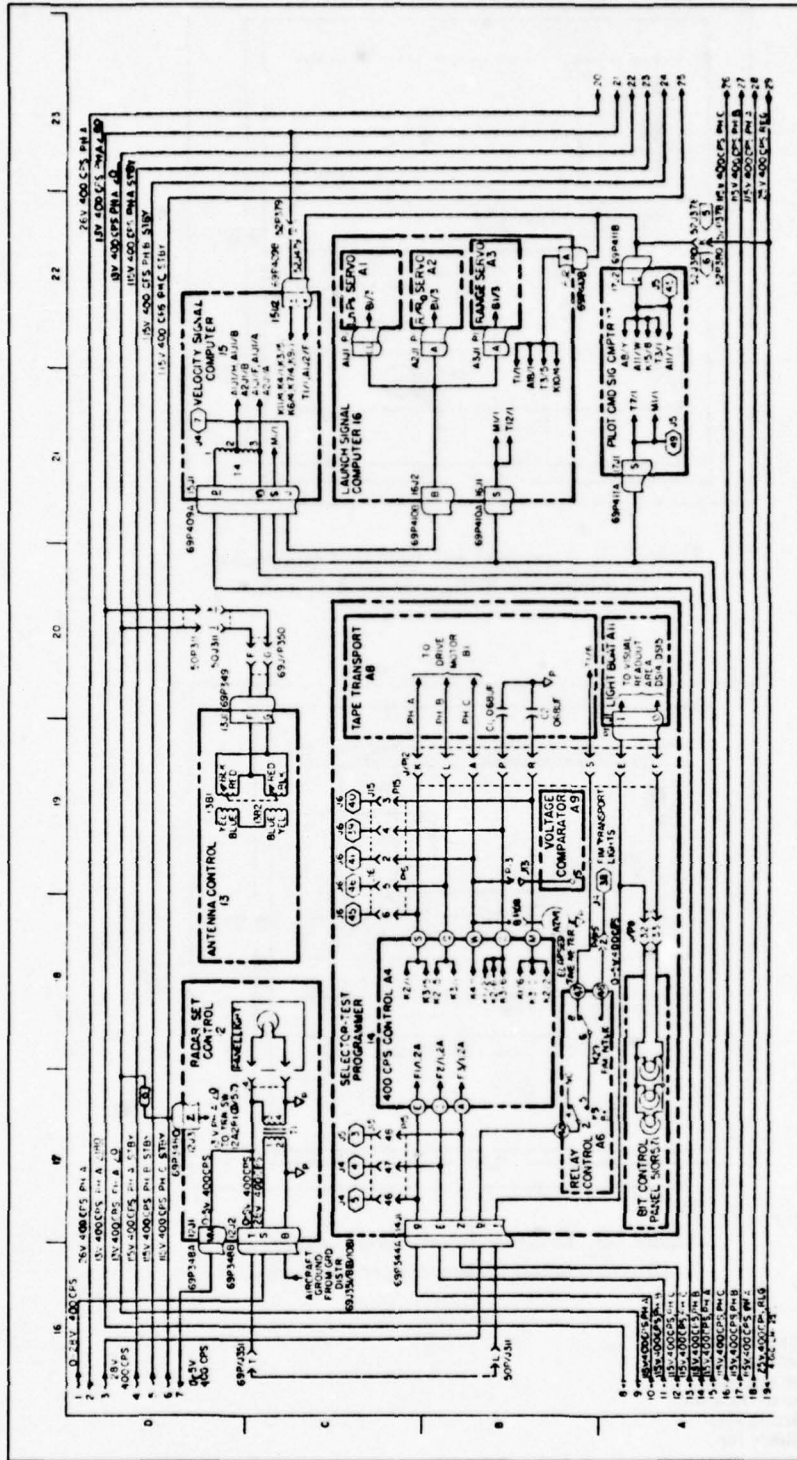

Figure 7-1. Illustration of Information Compression.

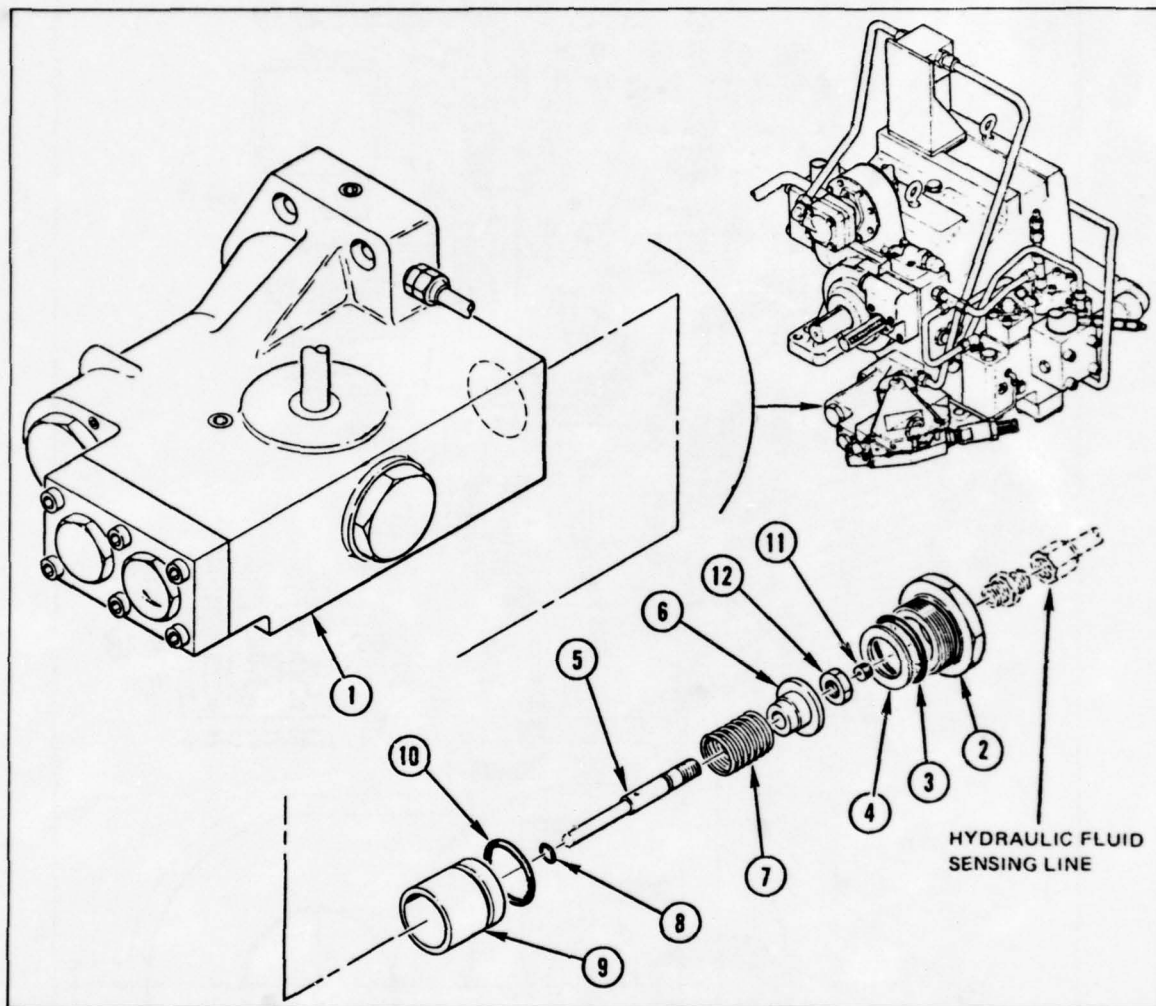

Figure 7-4. Sample Illustration Showing Acceptable Size.

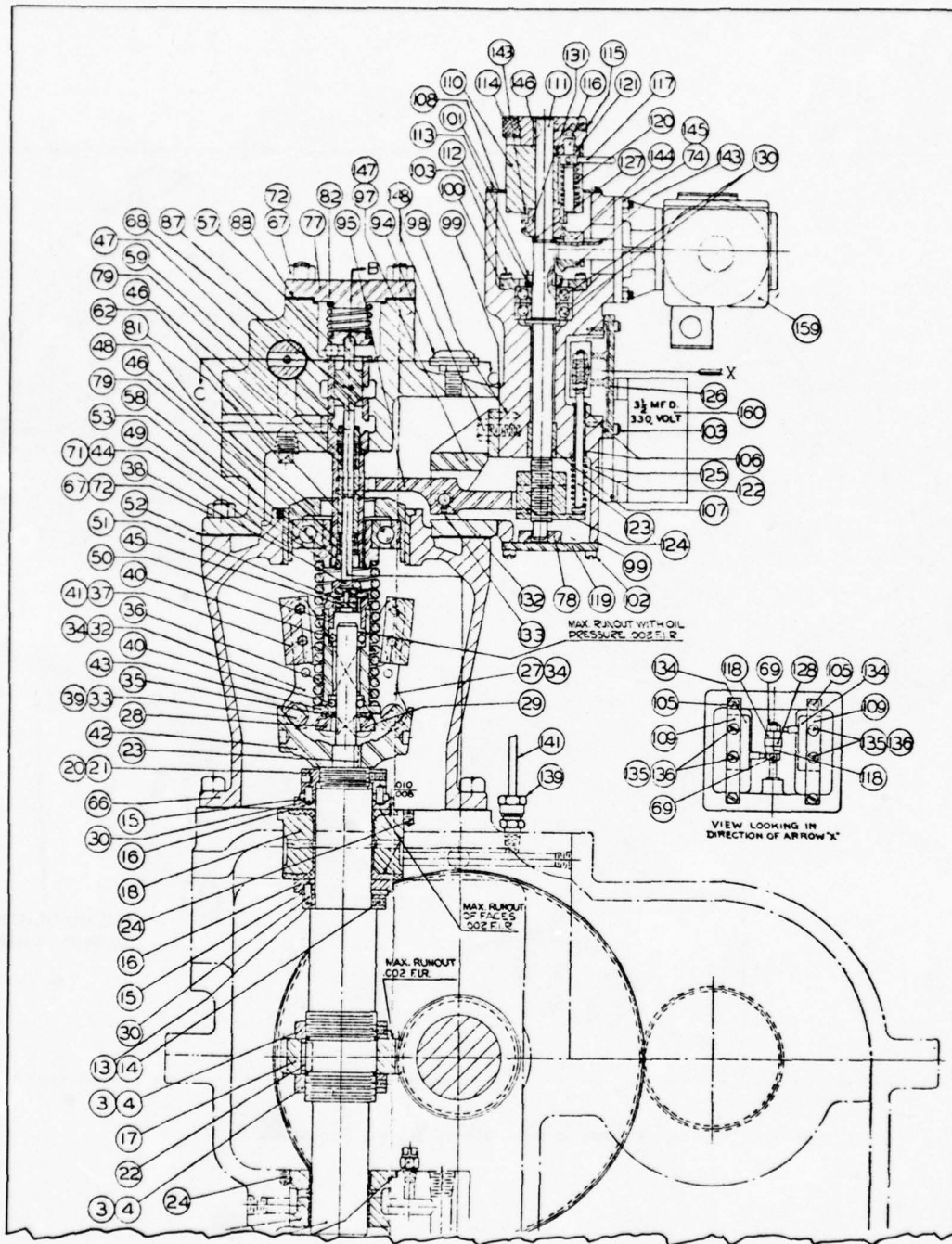

Figure 7-5. Illustration of Information Compression in a Mechanical Situation.

Test 8. Equipment Description Review

Equipment descriptions occur under a variety of titles, e.g., functional descriptions, theory of operation, and principles of operation. Regardless of the title, the treatment usually includes narrative material accompanied by functional or schematic diagrams. These materials are considered one of the more complex manual topics. Equipment descriptions frequently suffer from information compression. However, the symptoms and cures are different from those discussed earlier.

In printed prose, the presentation is organized by paragraph. Paragraph formats tend to bury or "embed" important points, creating comprehension problems for users, especially poor readers. For example, glance at Figure 8-1 and try to determine the number of points treated. It is difficult to do. Before suggesting solutions for this problem, consider a related type of complexity. The paragraphs of Figure 8-1 obviously relate to the accompanying schematic. However, the relatively large

amount of schematic information causes the user to search for the portions being discussed.

The suggested solution is to "itemize" both the narrative and diagrammatic portions of the equipment description. A sample format for this itemization is shown in Figure 8-2. Only minor wording changes were made to the original text but the points are "spread out" to heighten visibility. Nothing is changed in the diagram except that the relevant information has been highlighted and placed closer to its descriptive prose material. The effect is to eliminate much of the search effort involved in finding the narrative points and relating them to the relevant portions of the diagram. Figure 8-3 illustrates itemization applied to a mechanical system. Variations of this format are acceptable as long as the notion of itemizing points is retained along with the proximity of the narrative and diagram portions of the presentation.

(2) SHORT RAMP - Q101, C101, CR101, R101, R102, R103, R104, and R105 make up a constant current source. Q101 pumps a constant value of current into charging capacitor C101, regardless of the voltage across C101. The voltage across R104, divided by its resistance, determines the amount of current being pumped into C101. Potentiometer R102 sets up the voltage to be applied across R104 and is, therefore, used to set the length of the ramp at approximately 170 microseconds. Switch Q104 shorts across C101 when the ramp has reached its prescribed length.

Q109 and Q110 and the associated circuitry comprise a flip-flop which is used to start both the long and short ramp circuits upon receipt of a radar trigger. Initially, Q109 is on and Q110 is off. Q110 being off, places a negative potential on the base of Q104, the short ramp switch, causing Q104 to conduct, shorting out charging capacitor C101. R121, R122 and CR105 form a limiting circuit which limits the amplitude of the incoming radar trigger to 5v. The radar trigger is coupled to the base of Q109 then C108 and CR106, turning Q109 off and Q110 on. When Q110 comes on, one side of R107 and C102 are grounded causing Q104 to turn off. When Q104 turns off, charging capacitor C101 starts charging. Q102, Q103, and Q105 make up a gain-of-two amplifier. The amplified ramp signal is coupled through CR103 to the base of Q106.

Q106 and Q107 form a differential comparator circuit that is used to compare the short ramp voltage to a preset voltage. When the two voltages are equal, the comparator output causes the input flip-flop to reset, preparing the circuit for the next radar trigger.

Initially, Q106 is on and Q107 is off. When the ramp voltage being applied to the anode of CR103 equals the voltage on the anode of CR104, Q106 turns off and Q107 turns on, causing Q108 to turn on. When Q108 turns on, it resets the input flip-flop, thus preparing the circuit for the next radar trigger. The short ramp output is taken from the junction of R114, R115, and CR103 and fed out at pin A.

Figure 8-1. (Sheet 1 of 2). Partial Narrative of Equipment Description Illustrating Compression Problem.

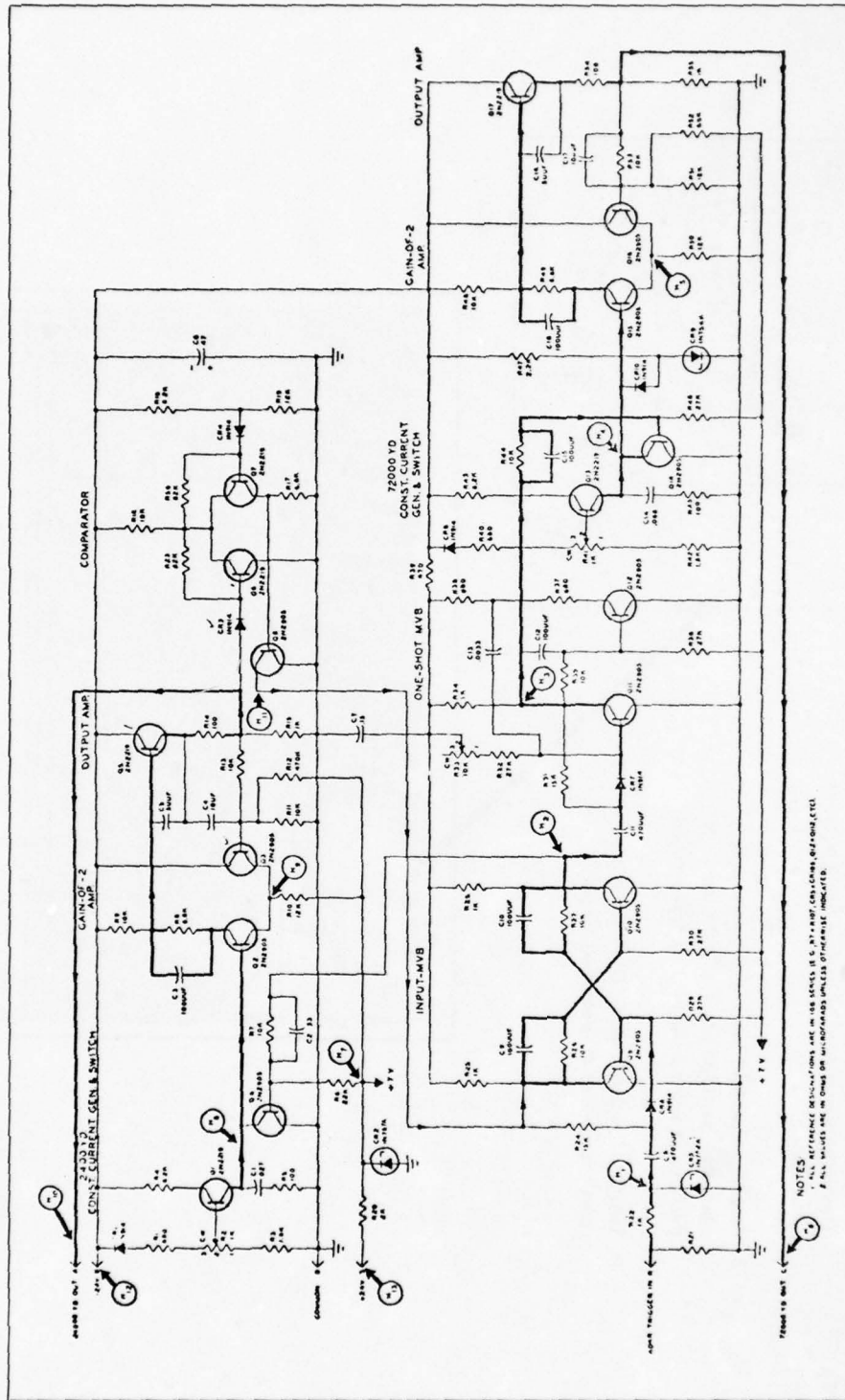

NOTES:
 1. ALL REFERENCE DESIGNATIONS ARE IN THE SCHEMATIC OF THE UNIT.
 2. ALL VALUES ARE IN OHMS OR MICROGRAMS UNLESS OTHERWISE INDICATED.

Figure 8-1. (Sheet 2 of 2). Schematic Portion of Equipment Description Illustrating Compression Problems.

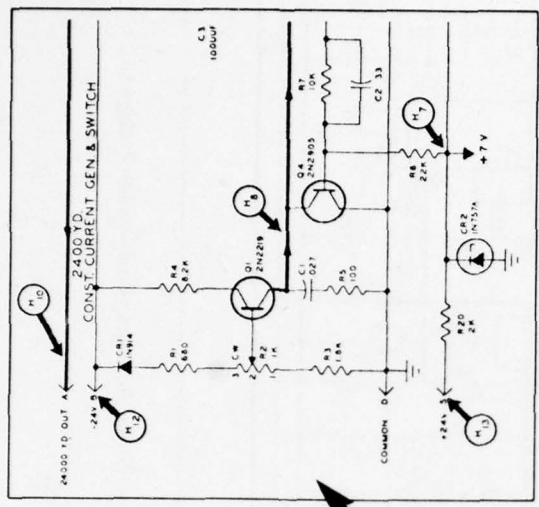

1. Q101 pumps a constant valve of current into charging capacitor C101, regardless of the voltage across C101.
2. The voltage across R104 divided by its resistance determines the amount of current being pumped into C101.
3. Potentiometer R102 sets up the voltage to be applied across R104 which sets the length of the ramp at approximately 170 microseconds.
4. Switch Q104 shorts across C101 when the ramp has reached its prescribed length.

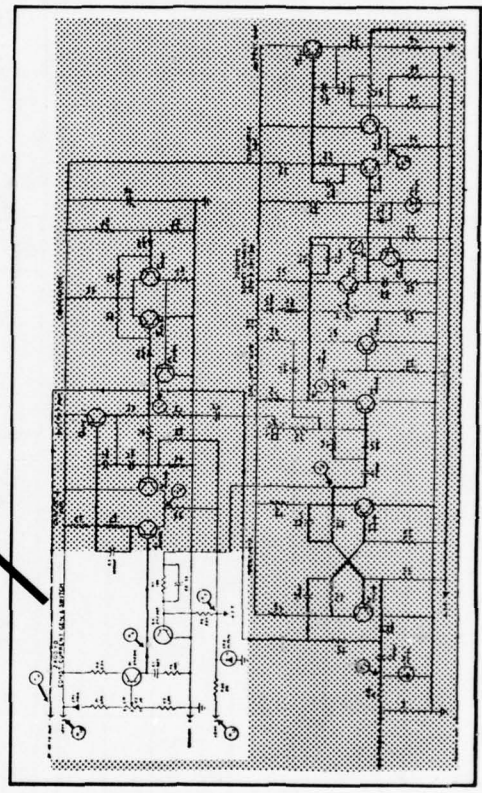

Figure 8-2. Illustration of an "Itemized" Description (Electronic).

CONTROL COLUMNS

1. The pilot's and copilot's control columns (1) are pivoted at the flight station floor (7).
2. The columns are restricted by aft and forward stops (9-10) to a travel range of 5" forward and 8½" aft of neutral position.
3. The foot of each column is connected by pushrod (5) and bellcrank (6) linkage to a combination cable quadrant and cable tension regulator (2).
4. The pilot's and copilot's tension regulator input cranks (6) are interconnected by a pushrod (8) so that both columns move in unison.
5. A control column shaker (3) is mounted on the lower section of each control column.

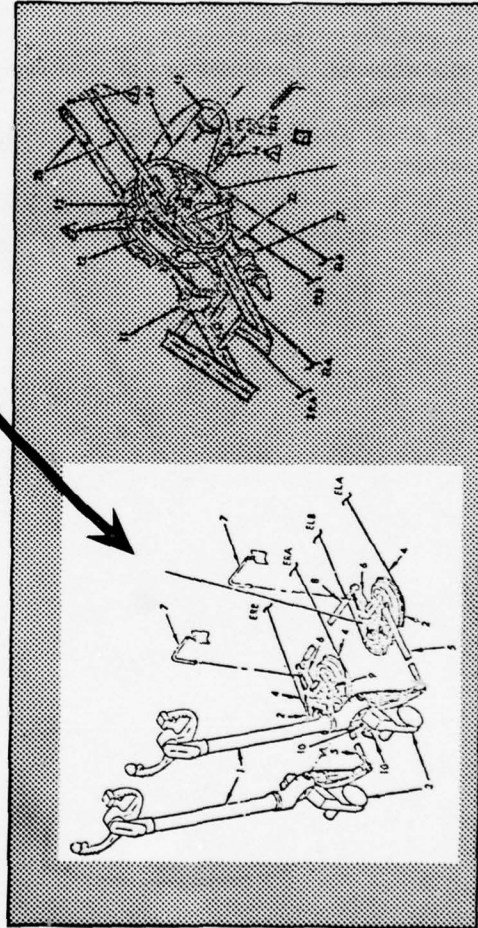
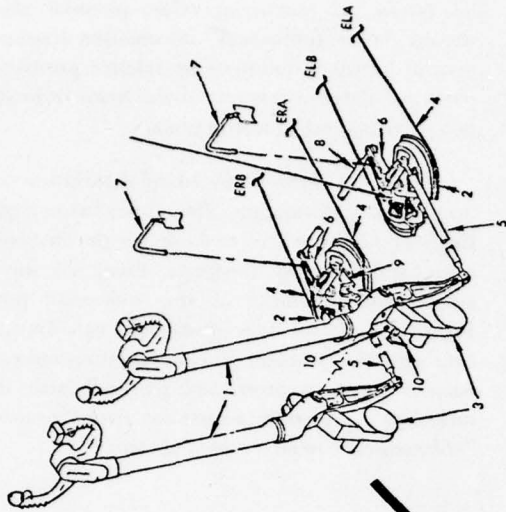

Figure 8-3. Example of "Itemized" Description (Mechanical).

Test 9. Narrative-Pictorial Balance Check

Procedural presentations often minimize the importance of pictorial information. Those sections of the manual which present maintenance procedures should be reviewed for narrative-pictorial balance. *Each step in the procedure should be assessed with respect to the need for one or more pictorials to reduce the possibility of error.* Error potential exists whenever a narrative step contains reference to:

1. A particular equipment location.
2. The relationships between two or more equipment items.
3. A specific equipment manipulation (e.g., valve rotation).
4. A test readout which is continuous (e.g., waveform) rather than discrete (e.g., numerical value).

To be of maximum value, pictorial information should show "contextual" information (background or general location) followed by relative positions of key parts and detailed features of the items to be dealt with in a particular set of instructions.

Figure 9-1 shows a procedural description containing no pictorial information. This presentation requires that the user knows where to look for the involved equipment and how to recognize them, an unwarranted assumption for most of the technician population. Figure 9-2 shows how pictorials can be added to overcome this problem. The presentation shows a proper balance between prose and pictorial with the latter including a *preferred progression from "contextual" to "enlargement" to an "exploded view."*

5-38. C-8014/AWE-1 PROGRAMMER CONTROLLER REMOVAL AND INSTALLATION. (A-7B Airplanes and A-7A Airplanes after A-7 Airframe Change No. 2.)

5-39. Removal.

a. Remove roller map display indicator (NAVAIR 01-45AAA-2-24).

a-1. Reaching behind controller, remove clamp and string ties from controller pigtail.

b. Disconnect pigtail electrical connector from mounted receptacle.

c. Remove three screws securing controller. One screw and washer located under bottom edge of auxiliary panel and two screws located at top edge of controller.

d. Remove controller from panel.

5-40. Installation.

a. Insert controller into auxiliary armament panel and secure with two screws at top of controller and one screw and washer at bottom of auxiliary panel.

Note

Replacement control panel may contain 28-volt edge-lighting panel lamps. If 28-volt lamps are installed in control panel, remove lamps and replace with 6-volt lamps (MS25237-327).

b. Connect controller pigtail to electrical receptacle and secure with clamp and string ties.

Figure 9-1. Illustration of Imbalance in Favor of Prose.

REMOVE BOTTOM TACAN ANTENNA ASSEMBLY

CAUTION

Do not use knives or sharp metal instruments to remove sealant. They scratch the surface.

1. Remove aerodynamic sealant from edge of antenna with sharp plastic scraper.

CAUTION

Antenna must be supported by one hand during removal so it will not be damaged.

2. Remove mount screws. Lower antenna out of fuselage.
3. Unscrew two connectors. Label both connectors and terminals on antenna.
4. Remove all gasket material.
5. Remove remaining sealant from edges of antenna and fuselage with plastic scraper.

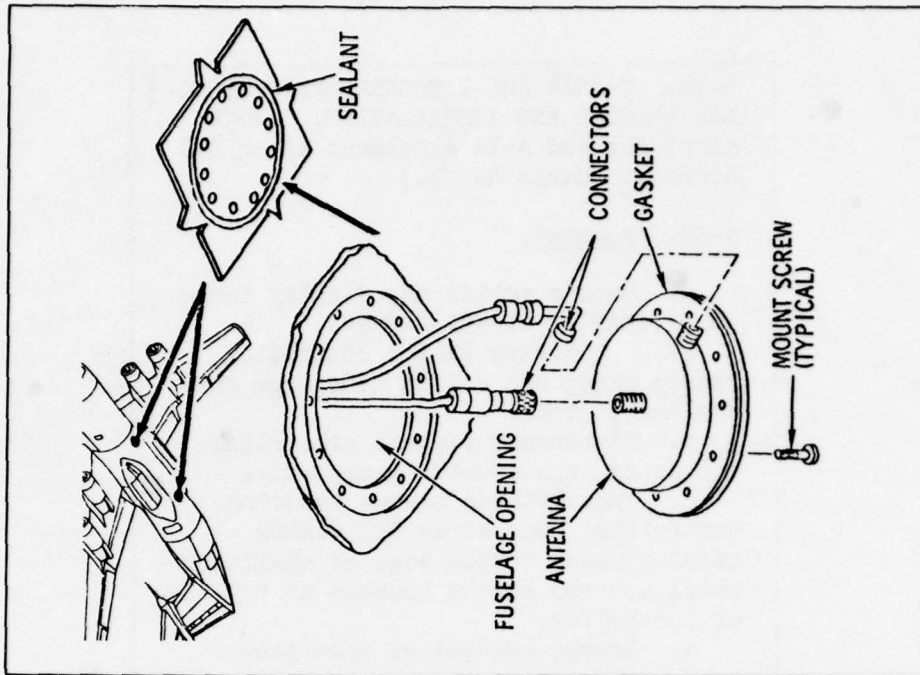

Figure 9-2. Proper Balance Between Prose and Graphics.

Test 10. Troubleshooting Procedures Need

The intent of schematics, wiring diagrams, and functional diagrams is to support troubleshooting performance. However, rather than telling the technicians what to do, these materials represent the system hardware in a way designed to allow the user to devise his own procedures. Thus, these types of troubleshooting aids are "reference" rather than "guideline" materials. Such reference-type presentations are often inadequate for technicians with little job experience. Therefore, a very important rewrite decision is whether to augment troubleshooting reference aids with guideline material.

This decision is not simple. Each of the following factors must be considered:

Complexity – Is the equipment so complicated by feedback loops, dependencies, and contingencies that simple "input-output" logic cannot be used for troubleshooting?

Frequency – Is the activity performed infrequently?

Time – Is it important to minimize time when performing the activity?

Safety – Could damage to either personnel or equipment occur as a result of poor task performance?

Procedures are warranted when the answers to the above questions tend to be Yes.

Procedural support can take many forms from specific "step x step" statements (see Figure 10-1) to brief symptom-cause charts (see Figure 10-2). Because they are amenable to conventional size, both these presentations formats are compatible with microform-based systems. A "logic tree," illustrated in Figure 10-3, is also appropriate for helping inexperienced technicians to interpret schematics, but this format is not recommended for microform-based systems.

No matter which of these three forms of procedural support you select, you should avoid a completely directive approach, viz., tell only what to do, not why. Adding "why" information (illustrated in brackets in Figure 10-3) eliminates the pure regimentation criticized by so many technicians.

The usefulness of wiring diagrams can frequently be improved by adding guideline information. Figure 10-4 illustrates a typical wiring diagram which is supposed to aid the technician in identifying connected terminal points, a tedious job even under ideal workspace and illumination conditions. An effective relief for this problem is the type of table illustrated in Figure 10-5. Geographic coordinates (e.g., A-2, C-6) may be included to assist the technician in tracing the wiring path on the original diagram.

CAMERA TROUBLESHOOTING

Shutter Will Not Open, UV Lamp (Blue Light) Flash Normal

1. Set meter mode switch (4) to -DC and meter range switch (5) to 2.5V. Connect meter probe (2) to point (7). Meter (6) should indicate greater than 0.5.
2. If meter (6) indicates less than 0.5, replace resistor R12 (9). If meter (6) indicates greater than 0.5, disconnect camera power plug from wall receptacle.
3. Disconnect meter black test lead (3) from point (10) and set meter range switch (5) to R x 10,000.
4. Clip black test lead (3) to the tip of the red test lead (2). Adjust multimeter ZERO OHMS control (1) until meter needle indicates 0, on right of scale.
5. Connect meter black test lead to point (10). Connect meter probe to point (7). Meter (6) should indicate less than 1.8 on top scale.
6. If meter (6) indicates less than 1.8, replace transistor Q12 (11). If meter (6) indicates greater than 1.8, replace resistor R16 (8).

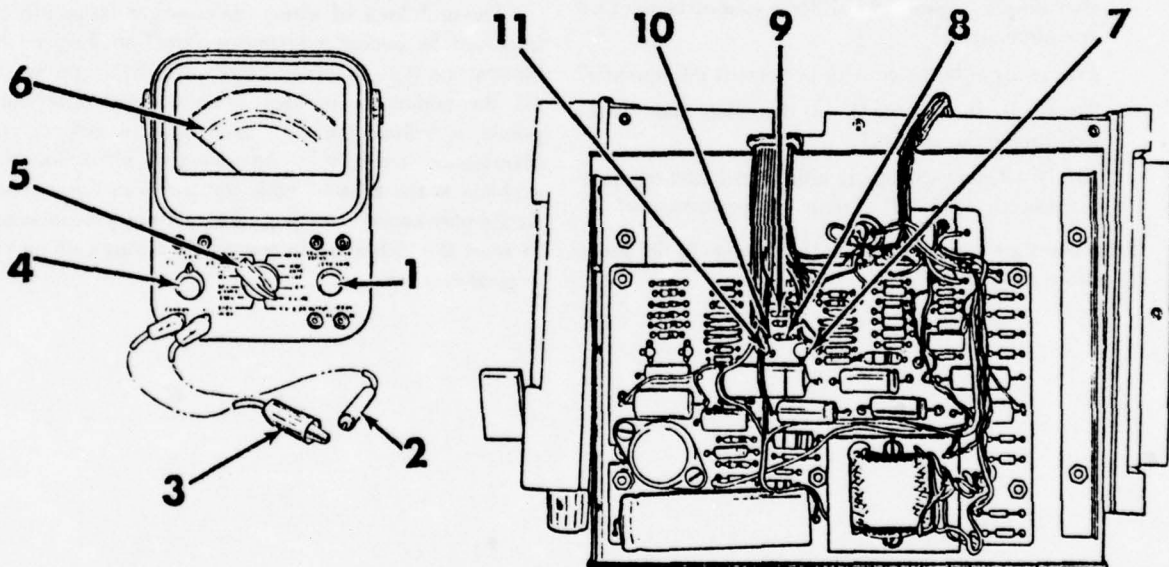

Figure 10-1. Illustration of Step x Step Format for Troubleshooting Guidance Aid.

| SYMPTOM | PROBABLE CAUSE | CHECK |
|---|--|---|
| Generator field cannot be flashed (cont'd). | Both sides of one phase of rectifier CR1 shorted. | Lift the brushes from the generator slip rings and measure forward and reverse resistance of rectifier CR1 as explained in Para. 4-5-1. |
| Generator voltage drops to zero when flashing power is removed (after holding switch S1 in "FLASH" position for several seconds). or Low generator voltage with little or no control in "MANUAL". | Open lead in exciter. One or more legs of rectifier in CR1 shorted. | Check connections to transformer T1, T2, T3, inductors L1, L2, L3 and rectifier CR1. Disconnect all connections to rectifier CR1 by removing a-c leads from bus bars on top of the generator and by lifting the brushes. Test the rectifier CR1 as explained in Para. 4-5-1. |
| High generator voltage in "MANUAL" and manual control rheostat R14 has little or no control. | Open lead in exciter control winding circuit. | Check for "open" in wiring and in all components of control winding circuit (T1, T2, T3, R14, CR7, R11 A, B, C, S1). |
| Operation is normal in "MANUAL" but general voltage is high in "AUTOMATIC" and voltage adjusting rheostat R4 has little or no control. | Open lead in switch S1 or in regulator second stage amplifier. | Check for "open" in wiring and in all components of control winding circuit (S1, R10, CR5, L5, T5). |

Figure 10-2. Illustration of Symptom - Cause Format for Troubleshooting Guidance Aids.

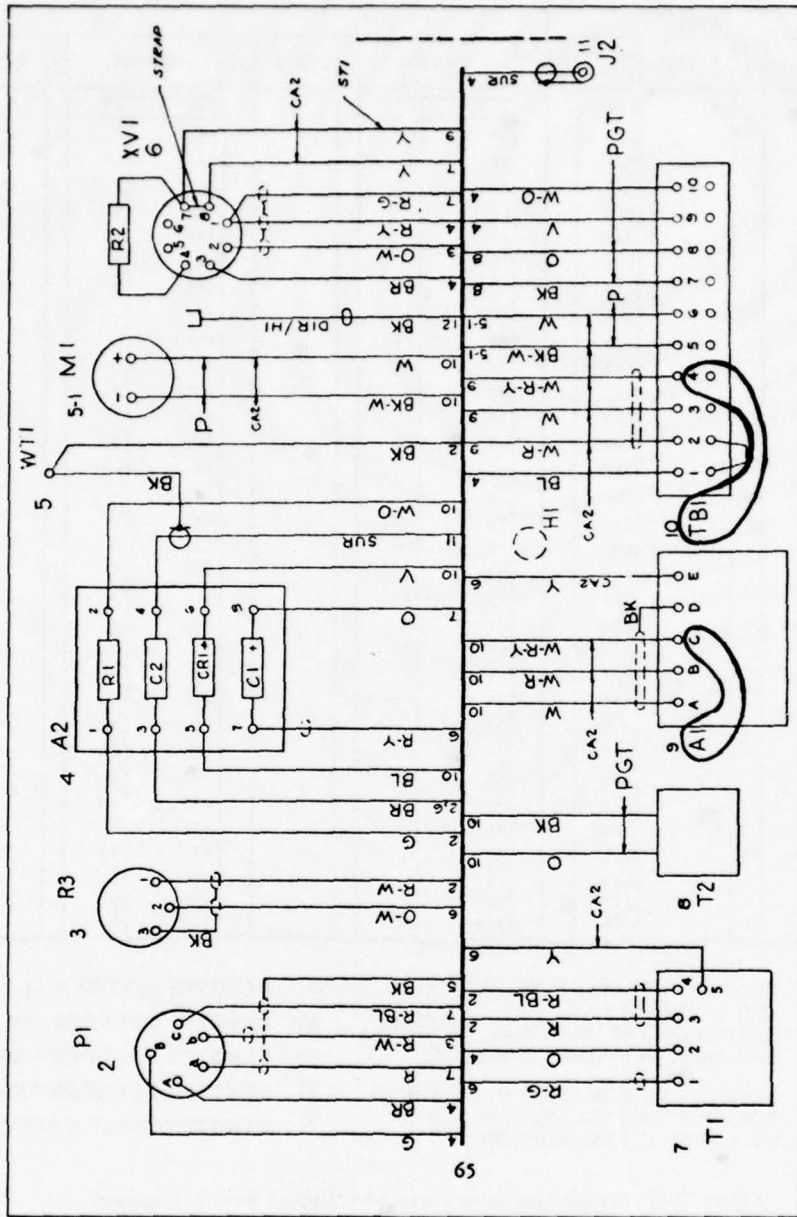

Figure 10-4. Sample Wiring Diagram.

| REV | | WIRE | | | | FROM | | | TO | | | | | |
|-----|------|-------|-----|--------|----------------|------|----------|----------|-------|-------|----------|----------|-------|-------|
| SYM | TRAN | COLOR | AWG | SYMBOL | METHOD OR PATH | NOTE | AREA LOC | TERMINAL | LEVEL | NOTES | AREA LOC | TERMINAL | LEVEL | NOTES |
| | | W-R-Y | | ST1 | CA2 | | A1 | C | | | TB1 | 4 | | |
| | | BK | | | CA2 | | A1 | C\$ | | | A1 | D | | |
| | | BK | | | CA2 | | A1 | D | | | A1 | C\$ | | |
| | | Y | | | CA2 | | A1 | E | | | XV1 | 7 (ST1) | | |
| | | G | | | CA1 | | A2 | 1 | | | P1 | B | | |
| | | W-B | | | CA1 | | A2 | 2 | | | TB1 | 10 | | |
| | | BR | | | CA1 | | A2 | 3 | | | P1 | A | | |
| | | BR | | | CA1 | | A2 | 3 | | | XV1 | 3 | | |
| | | | RF | | SUR | | A2 | 4 | | | J2 | | | |
| | | BK | | | SUR | | A2 | 4\$ | | | WT1 | | | |
| | | EL | | | CA1 | | A2 | 5 | | | TB1 | 1 | | |
| | | V | | | CA1 | | A2 | 6 | | | TB1 | 9 | | |
| | | R-Y | | SS3 | CA1 | | A2 | 7 | | | XV1 | 1 | | |
| | | Ø | | | CA1 | | A2 | 8 | | | T1 | 2 | | |
| | | BK | | H1 | DIR | | J1 | | | | V1 | CAP | | |
| | | | RF | | SUR | | J2 | | | | A2 | 4 | | |
| | | BK-W | | P1 | CA2 | | M1 | NEG | | | TB1 | 5 | | |
| | | W | | P1 | CA2 | | M1 | PØS | | | TB1 | 6 | | |
| | | BR | | | CA1 | | P1 | A | | | A2 | 3 | | |
| | | R | | SP1 | CA1 | | P1 | A* | | | T1 | 3 | | |
| | | G | | | CA1 | | P1 | B | | | A2 | 1 | | |
| | | R-W | | SS1 | CA1 | | P1 | B* | | | R3 | 1 | | |
| | | R-BL | | SP1 | CA1 | | P1 | C | | | T1 | 4 | | |
| | | BK | | | CA1 | | P1 | C\$ | | | WT1 | | | |
| | | R-W | | SS1 | CA1 | | R3 | 1 | | | P1 | B* | | |
| | | ØØØ | | | CA1 | | R3 | 1\$ | | | R3 | 2\$ | | |
| | | Ø-W | | SS2 | CA1 | | R3 | 2 | | | XV1 | 2 | | |
| | | ØØØ | | | CA1 | | R3 | 2\$ | | | R3 | 1\$ | | |
| | | BK | | | CA1 | | R3 | 2\$ | | | R3 | 3 | | |
| | | BK | | | CA1 | | R3 | 3 | | | R3 | 2\$ | | |
| | | BL | | | CA1 | | TB1 | 1 | | | A2 | 5 | | |
| | | MS1 | | | CA1 | | TB1 | 1 | | | TB1 | 2 | | |
| | | Y | | | CA2 | | XV1 | 8 | | | T1 | 5 | | |

NOTES \$ DENOTES TERMINATION OF SHIELD AND IS PREFIXED BY THE DESIGNATION OF THE TERMINAL TO WHICH THE SHIELDED WIRE CONNECTS. MS DENOTES MECHANICAL STRAP

COM DENOTES TERMINATION OF A SHIELD COMMONED WITH A SECOND SHIELD BY A SINGLE TERMINATION. SS DENOTES SHIELDED SINGLE

SP DENOTES SHIELDED PAIR ST DENOTES SHIELDED TRIPLE

* DENOTES LOWER CASE LETTER

Figure 10-5. Sample Guidance Format to Support Wiring Diagrams.

READABILITY REQUIREMENTS

Rationale

Certain writing techniques are capable of improving readership (the inclination of users to read a manuscript); readability (how quickly and easily material can be read); and comprehensibility (the percentage of readers who grasp key points of the passage). For these reasons, *your manuscripts should reflect the use of these writing techniques*. The readability improvements apply only to the continuous discourse parts of your draft manuscript (*viz.*, material that is predominantly prose, in paragraph format). Therefore, it will be necessary for you to select this type of passage from your draft, apply the readability tests, and rewrite where indicated.

Requirements

The following general requirements aim at a 9th grade level of readability:

- Paragraph headings should be used to facilitate access and to identify the type of material which will follow.
- Paragraphs should be limited to one, two, or three topic sentences.
- Words per paragraph and words per sentence should be limited to minimize structural ties required of the user.
- Long and unfamiliar words should be avoided.
- Pictorials should be used to introduce key equipment terminology used in prose discussions.
- Layout should enhance reading speed and comprehension.

Test 11. Headings Review

Paragraph headings serve two purposes. First, they ease access by permitting the reader to scan a page to find material he wants. Second, they alert the reader to the type of information contained in the paragraph, thereby enhancing readability. Obviously, all major paragraphs require headings, but no standards exist to determine how many of your subparagraphs must have lead-ins or headings. *A standard of 50% is suggested. Add headings of about three or four words where less than half of your subparagraphs have lead-ins.*

Reading tends to be easier and more efficient when the text covers what the reader expected it to cover. Chapter and paragraph headings are important clues a reader uses to build his expectancies. Therefore, *all material within a paragraph should be consistent with its paragraph heading.* Figure 11-1 is a sample TM manual passage which violates this rule. The encircled information in the figure is a description of *equipment composition* while the paragraph heading alerts the reader to a discussion of *manual purpose*.

Lack of topic consistency between paragraphs and overview material is more difficult to spot and more disruptive to the reader. Figure 11-2 illustrates such a consistency error. The enclosed excerpt shows subparagraphs (b) and (c) of paragraph 4-1. The titles at the top show all topics discussed under paragraph 4-1. The continuity error is that subparagraph (b) and Figure 4-1 lead the reader to expect that four basic functions of the system will be discussed and that they will be discussed in the order shown in the figure. Contrary to this expectation, the last function is discussed first [subparagraph (c)]; none of the remaining three functions are discussed (compare topics at top of Figure 11-2 with basic functions shown in Figure 4-1); and two un-introduced topics are discussed (channel function and video output). This lack of continuity is disconcerting, causing the reader to reread material he has already read, look elsewhere for the material he expected to find, and generally lose confidence in the credibility of the manual.

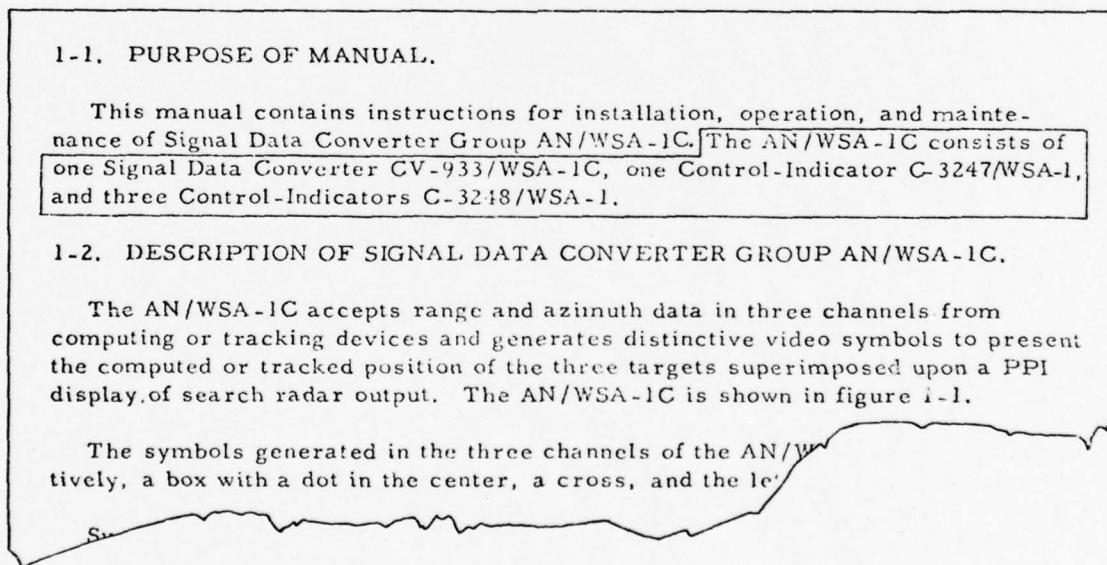

Figure 11-1. Illustration of Text Placed in Wrong Paragraph.

4-1 Overall Functional Description

- a. General
- b. Basic Process (e.g., Conversion, Synchronization, Pulse Generation, Symbol Forming)
- c. Symbol Forming
- d. Channel Function
- e. Video Output

b. THE BASIC PROCESS. - The AN/WSA-1C processes the range and azimuth input data in three separate channels. The process performed consists of four basic steps as shown in figure 4-1. The first step is conversion of the data to a form usable for synchronization with the range and azimuth sweeps of the indicator. The second step is synchronization of the data with the range and azimuth sweeps of the indicator. The third step is generation of pulses so synchronized that they will form the range and azimuth components of the video symbols. The fourth step is selective gating and mixing of the pulses in the three channels to produce three distinctive symbols.

c. SYMBOL FORMATION. - The symbols generated are a box, a cross, and the letter H as shown in figure 4-2. In order to generate these symbols, the range and azimuth pulses shown in figure 4-3 are generated, selectively gated, and mixed to form symbol video.

(1) SIMPLIFIED SYMBOL FORMATION. The symbols are actually formed by segments of the range sweep as shown in figure 4-4. The upright or radial sides of the symbols are relatively long (10-1/2 percent of the range of the symbol). The circumferential lines in the symbols are composed of segments of the range sweep which are relatively very short.

(2) DEFINITION OF TERMS. - The following are definitions of terms peculiar to symbol formation in the AN/WSA-1C.

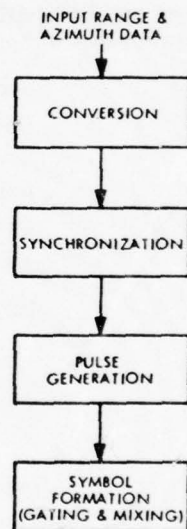

Figure 4-1. Signal Data Conversion, Basic Block Diagram

Figure 11-2. Illustration of Topical Discontinuity.

Test 12. Topic Sentence Check

Each paragraph of your prose material should cover one, two, or possibly three main points. To check your work against this standard, read each paragraph and underline topic sentences or key points. Consider breaking paragraphs with three or four main points into two paragraphs.

If a paragraph has many key points, say six or seven, consider an alternative tabular presentation. Figure 12-1 shows an "all prose, paragraph" presentation which treats seven key points. Restructuring into seven short paragraphs is a marginal solution. Figure 12-2 shows a more concise and readable tabular version of the same seven points edited to eliminate the excess verbiage. The original version contains 26 lines of text which buried main points in a paragraph format. The tabular version is much shorter and provides a great deal more visibility to each of the seven key points. You will have to use your

judgment to determine whether the alternative presentation should replace or augment the original version. Using our 26-line sample to illustrate, you may wish to retain the prose version and add the tabular presentation to summarize and emphasize the key points.

Vague or unclear topic sentences are common and very disruptive to the poor reader. If you understand all words of a paragraph but have to ask yourself "what was that all about," the paragraph has one or more vague topic sentences. The paragraph should be reviewed in an effort to identify the topic(s) the writer was attempting to discuss. Where topics can be identified, you must rewrite emphasizing these points. Where you find it difficult to identify topic sentences, consider eliminating the material. Before you eliminate any material, however, make sure the problem is vague writing as opposed to clear writing on a difficult topic.

service the equipment properly. (1) The advisability of applying power to defective equipment should be carefully considered from the standpoint of causing danger to personnel and further damage to the equipment.

After the trouble has been determined to be internal, (2) the AN/USM-105 oscilloscope should be used to compare the waveforms given in the troubleshooting charts, on the schematic diagrams, and in the waveform charts with the waveforms in the equipment. It is important to use the AN/USM-105 because many of the waveforms present in the equipment are very fast pulses which will not be displayed properly on an oscilloscope with a bandpass of less than 15 megacycles. Waveform comparisons are the most effective method of servicing this equipment. (3) Resistance measurements made on transistor circuits have little value because of the low-impedance and current-sensitive properties of transistors. (4) When a component is replaced on a printed circuit card on which an adjustment is located, the setting of the adjustment should be verified by reference to the alignment procedure in Section 6.

CAUTION

(5) Before replacing components located on a printed circuit card, study the instructions for printed circuit repair given in Section 6. Improper repair techniques may damage or destroy printed circuit cards.

It is important when making waveform, voltage, or resistance measurements that the controls (6) on the equipment and test equipment be set as required for the test. When the trouble has been found to be the result of a defective printed circuit card, the defective component or components should be located by a careful analysis using the waveform and voltage data. This equipment has no parts with the exception of light bulbs which have a definite limited life; therefore, (2) before replacing a printed circuit card or component it should be determined that the voltages into the printed circuit card are of the proper value to insure that the component failure was not caused by a failure elsewhere in the equipment.

Figure 12-1. Sample of Text Which Buries Important Topics.

| REMEMBER THESE POINTS! | |
|------------------------|--|
| 1. | Is it safe to apply power? |
| 2. | You need an oscilloscope with a bandpass greater than 15 megacycles. |
| 3. | Resistance measurements are ineffective on transistor circuits. |
| 4. | Don't take short cuts in PCC component replacement. |
| 5. | You must adjust PCC after component replacement. |
| 6. | Use voltage data and waveforms to troubleshoot PCC. |
| 7. | Repair cause <u>and</u> symptom? |

Rewritten to replace 26 lines of text

Figure 12-2. Preferred Tabular Format.

Test 13. Words Per Paragraph Count

Long paragraphs are difficult to read, probably because they require the reader to make and retain many "structure ties." Ties are the connections a reader must make between words and phrases to derive meaning. To help minimize the number of structural ties you require of your readers, *try to limit paragraph length to about 45 to 60 words.*

In cases where you must exceed this limit, consider the use of "peak stress" methods to give visibility to the

more important points of the paragraph. The peak stress methods most suitable for maintenance manuals are underlining key phrases, using boldface print, or italicizing. The use of marginal notes is also a peak stress method but is considered too "unusual" and may detract from as much as it adds to readability. An important caution about peak stress is not to overdo it. For example, too much italicized print detracts from the readability of prose.

Test 14. Words Per Sentence Count

Excessive structural ties also result from too many words per sentence. *Research shows that your target technicians can read 17-word sentences. Set this goal for your own manuscripts. Where your sentences average more than 20 words, edit for the following problems.*

Compound Sentences

Compound sentences are composed of two or more independent clauses joined by and, but, or other connectives. An independent clause is one which can stand alone: "Check that the two TACAN couplers are installed" is an independent clause. An example of a compound sentence is "The transmitted signal is radiated to the ground and the reflected signal is received on the receiving antenna from which it is fed to the balanced detector." Breaking this sentence into two by using a period rather than "and" will increase its readability.

Complex Sentences

Sentences composed of one independent and one or more dependent clauses are complex sentences. Dependent clauses cannot stand alone. Here is an example (the dependent clause is italicized): "The receiver-transmitter generates a low frequency-

modulated microwave carrier, radiates this carrier downward from the aircraft, receives the reflected signal from the terrain, and produces an audio-frequency voltage, *the frequency of which is the difference between the instantaneous transmitted and received signal frequencies.*" Rewriting to make two sentences will improve readability.

Prepositional Phrases

Unnecessary prepositional phrases frequently add to the word count. Examples of such phrases and their preferred equivalents are:

along the lines of like
for the purpose of for
for the reason that since
from the point of view of . . . for
in accordance with by, under
in case of if
in the event that if
in the neighborhood of . . . about
on the basis of by
prior to before
with reference to about (or leave out)
with regard to about (or leave out)
with the result that so that

Passive to Active

Equipment descriptions are notorious for their use of the passive rather than the active voice. The passive is less familiar to readers, must include the acting agent in an awkward phrase, and requires an auxiliary verb which adds to the word count.

Poor: The error signal from the synchro rotor is clamped to a maximum of one volt by the CR601 and CR602 producing a voltage drop across R601.

Better: CR601 and CR602 clamp the error signal from the synchro rotor to a maximum of one volt...

Empty Words

Technical writing often includes words which look meaningful but are not. For example, "perform the required test" would be more helpful if the name of the test was given in place of the word "required." If the test to be performed is obvious from the previous statement, the word "required" is not needed. Three other words which you can frequently delete without damage to the meaning are: "concerned," "involved," and "respectively."

Modifiers

Strings of modifiers are hard to read and difficult to understand. The sample below is an illustration of the problem.

As furnished by the manufacturer, the AN/WSA-1C is compatible with any radar set capable of furnishing antenna azimuth as a three-wire, one-speed, 60-cps or 400-cps synchro data voltage. It is also compatible with any computing or tracking devices capable of furnishing azimuth as a three-wire, one-speed, 60-cps or 400-cps synchro data voltage and capable of furnishing range as a three-wire, one-speed, 60-cps or 400-cps synchro data voltage calibrated at 200 yards per degree. The operating frequency of the servo loops may be changed by changing synchros and motor generators.

Such phrasing is hard to read as continuous prose and would be better presented in the following format.

- Inputs: (1) Radar video
(2) Radar trigger with 20 ± 5 volts amplitude
(3) Radar antenna azimuth (3-wire, 1-speed, 60- or 400-cps synchro voltage)
(4) Three channels of target azimuth data (3-wire, 1-speed, 60- or 400-cps synchro voltage)

Test 15. Syllables Per Word Count

Research has shown that *your target technicians can read text averaging one and one-half syllables per word*. Unfortunately, manuals deal with lengthy, technical nomenclature, e.g., attenuator, modulator, unblanking and radial compensation circuit. Since such words are required, you should omit them when testing your draft for word length. To perform this test, count syllables per 100-word passages (omitting technical nomenclature). You should not have more than 150 syllables. If your drafts exceed this standard, review your text for lengthy words which might be replaced by shorter words or by two or more short words (dilution).*

- | | |
|-----------------------------|---------------------------|
| ascertain | find out |
| discontinue | stop |
| enable | let, allow |
| verify | check, test |
| accordingly | so |
| consequently | so |
| for this reason | then |
| in addition | besides, also |
| more specifically | for instance, for example |
| moreover | now, next |
| nevertheless | but, however |

*These and the examples for prepositions, conjunctions, and connectives are drawn from Flesch, R. *How to write, speak and think more effectively*. New York: New American Library, 1946.

Test 16. Equipment Nomenclature Check

Omitting lengthy and unfamiliar nomenclature from the word length test merely avoids a troublesome reading problem. One way to address this problem is to introduce technical terminology to the reader at the outset of the relevant passages. Figure 16-1 shows a pictorial with selected callouts, the appropriate means

for introducing new equipment terminology. You should check your prose to determine that *all* unfamiliar nomenclature is treated in the nomenclature pictorial. *Where the text uses an equipment name that is not included in the pictorial, either add the term to the pictorial or expand the text to define the new term.*

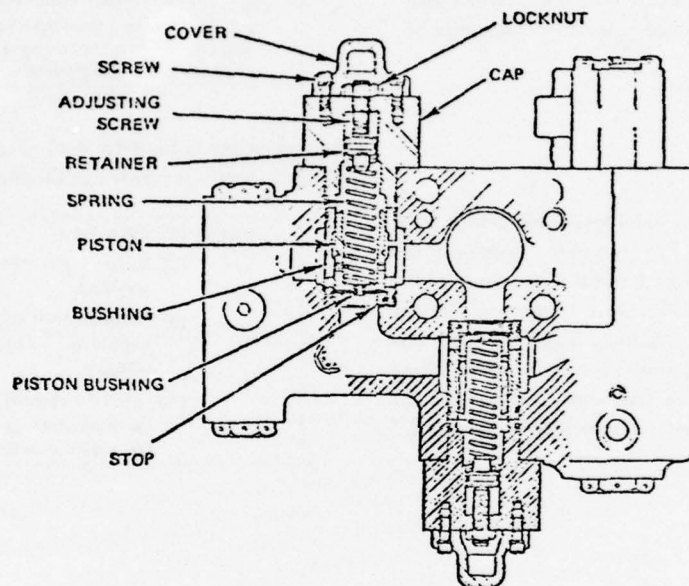

3-23. When the main system pressure (hoist or lower) reaches $3050 \begin{smallmatrix} +100 \\ -0 \end{smallmatrix}$ psi, the piston is moved against the force of the spring. As the relief valve piston moves, porting is opened between the piston and manifold to allow enough fluid to flow past the piston to the opposite side of the main loop to maintain the pressure setting. When pressure lowers below the valve setting, the spring forces the piston closed again.

Figure 16-1. Illustration of Equipment Nomenclature Pictorial.

Test 17. Layout Review

Layout of information within a page area or frame influences reading speed, comprehension, and preference. You should review two dominant text features to maximize these benefits. First, a *double column format is superior to a single column format*. This is illustrated in Figure 17-1. Second, *related materials should be contiguous*. This principle applies mainly to contiguity between prose and related graphic material. Graphics must be referenced in the text whenever they are used to support a conclusion drawn in

the text. Further, convention requires that graphics always follow the text reference. Guidelines for layout of graphics and related prose are:

1. Arrange prose and related graphics for simultaneous viewing.
2. Place small graphics at the bottom of a page.

Figures 17-2 and 17-3 illustrate good and poor examples of prose/graphic contiguity.

2-142. JETTISON SYSTEM.

2-143. The jettison system (figure 2-51 and table 2-1) has three jettison circuits, salvo, select, and auxiliary. When wing mounted weapons/stores are jettisoned using either salvo or select, everything below the MAU-9 ejector rack is released. The auxiliary circuit permits the jettisoning of rocket pods, CBU's, and bombs loaded on the MER/TER, retaining the racks on the MAU-9 ejector rack. Auxiliary jettisoning of wing mounted AIM-9 or AGM-87A-1 missiles fires the missile in an unarmed, unguided condition, retaining the launcher. Fuselage mounted AIM-9 or AGM-87A-1 missiles are fired unarmed and unguided using the select jettison circuit. See

figure 2-52 for circuit breakers used in the system.

2-144. SALVO JETT BUTTON. The SALVO JETT button (figure 2-53), located on the instrument board, is a momentary contact switch. The switch permits jettisoning of everything mounted on the MAU-9 ejector racks.

2-145. SEL JETT BUTTON. The SEL JETT button (figure 2-53), located on the instrument board, is a momentary contact switch. The switch permits jettisoning of all MAU-9 mounted weapons/stores from selected wing stations and the unarmed and unguided firing of fuselage mounted missiles.

2-142. JETTISON SYSTEM.

2-143. The jettison system (figure 2-51 and table 2-1) has three jettison circuits, salvo, select, and auxiliary. When wing mounted weapons/stores are jettisoned using either salvo or select, everything below the MAU-9 ejector rack is released. The auxiliary circuit permits the jettisoning of rocket pods, CBU's, and bombs loaded on the MER/TER, retaining the racks on the MAU-9 ejector rack. Auxiliary jettisoning of wing mounted AIM-9 or AGM-87A-1 missiles fires the missile in an unarmed, unguided condition, retaining the launcher. Fuselage mounted AIM-9 or AGM-87A-1 missiles are fired unarmed and unguided using the select jettison circuit. See figure 2-52 for circuit breakers used in the system.

2-144. SALVO JETT BUTTON. The SALVO JETT button (figure 2-53), located on the instrument board, is a momentary contact switch. The switch permits jettisoning of everything mounted on the MAU-9 ejector racks.

2-145. SEL JETT BUTTON. The SEL JETT button (figure 2-53), located on the instrument board, is a momentary contact switch. The switch permits jettisoning of all MAU-9 mounted weapons/stores from selected wing stations and the unarmed and unguided firing of fuselage mounted missiles.

Figure 17-1. Illustration of Preferred and Less Desirable Presentations for Narrative.

| PREPARATION | CHECK |
|---|--|
| <ol style="list-style-type: none"> 1. Apply external electrical power. 2. Hold control stick trim switch forward until trim actuator stops. 3. Remove external electrical power. | <p>Dimension X Detail B is 4.22 ± 0.03 inches.</p> <p style="text-align: center;"><u>NOTE</u></p> <p>If measurement is correct, go to next step. If measurement is incorrect, stop this activity and request that adjustment be made.</p> |
| <ol style="list-style-type: none"> 4. Apply external electrical power. 5. Hold trim switch aft until trim actuator stops. 6. Remove external electrical power. | <p>Dimension X is 0.32 ± 0.03 inches.</p> <p style="text-align: center;"><u>NOTE</u></p> <p>If measurement is correct, go to next step. If measurement is incorrect, stop this activity and request that adjustment be made.</p> |
| <ol style="list-style-type: none"> 7. Apply external electrical power to aircraft. 8. Position trim switch to obtain a neutral trim reading on indicator. 9. Remove external electrical power. | <p>Dimension X Detail B is 2.08 ± 0.03 inches.</p> <p style="text-align: center;"><u>NOTE</u></p> <p>If measurement is correct, go to next step. If measurement is incorrect, stop this activity and request that adjustment be made.</p> |
| <ol style="list-style-type: none"> 10. Apply external electrical power to aircraft. 11. Hold trim switch aft until actuator stops. 12. Ensure damper (1) is fully compressed. 13. Remove external electrical power. | <p>Dimension Y Detail C is 6.900 ± 0.015 inches.</p> |

Appears on page 5-1

Appears on page 5-23

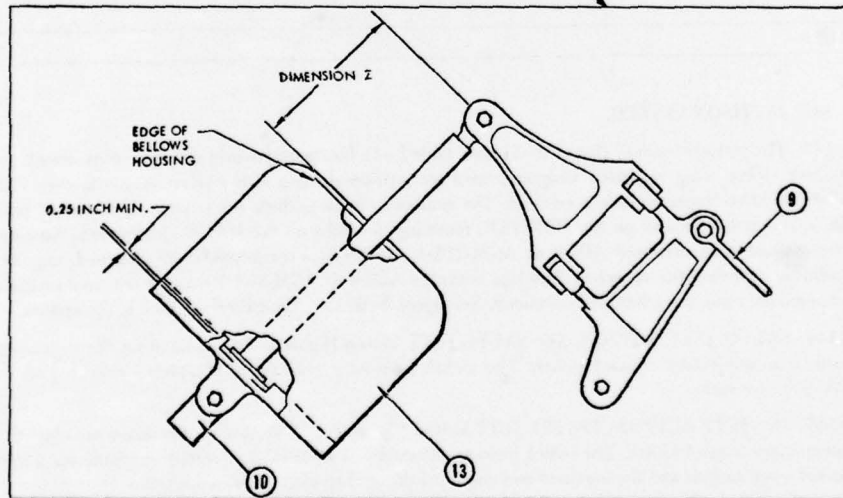

Figure 17-2. Illustration of Poor Contiguity Between Prose and Pictorial Material.

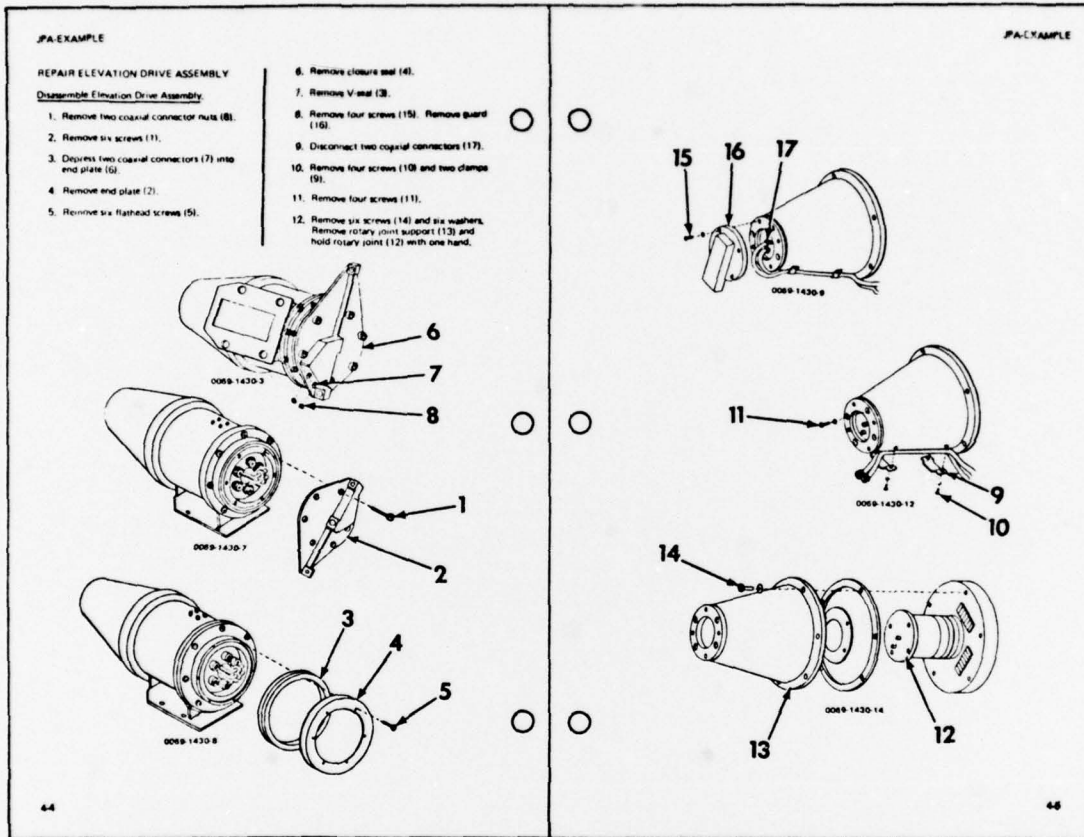

Figure 17-3. Mixed Prose and Pictorial Presentation Showing Good Contiguity.

SUMMARY OF REQUIREMENTS AND CRITERIA

The requirements and criteria for rewriting technical manuals to improve readability and comprehensibility have been presented in some detail. This section summarizes those requirements and criteria in a checklist form. These checklists may be used to review and rewrite a technical manual once the reader is thoroughly familiar with the rationale underlying the requirements and the tests which explain the use of the criteria.

Preceding Page BLANK -

ORGANIZATION REQUIREMENTS SUMMARY

Manual organization should be based on a hierarchy of maintainable units.

- Organize around a family tree or topdown breakdown of maintainable units.
- Organize for 1 to 10 ratio of superordinate to subordinate maintainable units.

A repair cycle overview should be included. This should be a diagrammatic representation of the succession of maintenance actions.

- Illustrate the succession of maintenance actions required to complete a repair cycle.
- Diagrammatic overviews should be used instead of or in support of any narrative.
- Use several overviews for larger systems.

All information concerning a maintainable unit should be consolidated into a single package.

- Eliminate "refer to" problems by consolidating all information about a maintainable unit.

The content, format, and sequence of information within a package should be standardized.

- Use a "local" table of contents to indicate material available within a package.
- Provide pictorials to introduce the reader to terminology and features of the maintainable unit.
- Provide a topdown breakdown which establishes the referents for the maintenance procedures of the package.
- Include operating descriptions in the package or under separate cover.
- Trouble analysis aids should immediately follow operating descriptions.
- Trouble analysis aids should be sequenced or grouped in a logical order.
- Include all nontroubleshooting procedures as the final content item in the maintainable unit package.

COMMUNICATION REQUIREMENTS SUMMARY

Presentations should include only that information required to support job performance.

Eliminate information which is not relevant to the job at hand.

The amount of information included in an image area should be controlled to prevent clutter.

- Limit schematics to 3 elements per square inch or less.
- Important dimensions of drawings should be at least 1/10 inch.
- Itemize both narrative and diagrammatic portions of Equipment Description materials.

The balance between narrative and pictorial should favor pictorial to minimize procedural errors and performance time. Provide pictorials when steps refer to:

- A particular equipment location.
- The relationship between two or more equipment items.
- A specific equipment manipulation (e.g., valve rotation)
- A test readout which is continuous (e.g., waveform) rather than discrete (e.g., numerical value)

Troubleshooting materials should include a mix of descriptive and instructional information.

- Add procedural presentations when warranted by consideration of troubleshooting complexity, frequency, time and safety.

READABILITY REQUIREMENTS SUMMARY

Paragraph headings should be used to facilitate access and to identify the type of material which will follow.

- 50% of the subparagraphs should have headings on leadins.
- Headings should be no more than 3 or 4 words.
- All material within a paragraph should be consistent with the paragraph heading.
- Paragraph headings should be consistent with expectancies established by overviews.

Paragraphs should be limited to a few topics which are clearly and concisely identified.

- Each paragraph of prose material should be limited to no more than three main points.
- Five or more key points in a paragraph may be presented better as a table.
- Topic sentences in a paragraph should be especially clear and concise.

Words per paragraph and words per sentence should be limited to reduce demands of memory and structural ties on the user.

- Limit paragraphs to 45-60 words.
- Limit sentences to 17-20 words.
- Use peak stress emphasis where lengthy paragraphs cannot be avoided.
- Change compound sentences to simple sentences.
- Change complex sentences to simple sentences.
- Change passive voice to active voice.
- Eliminate empty words.
- Eliminate prepositional phrases.
- Eliminate unnecessary modifiers.

Lengthy and unfamiliar words and sentences should be avoided.

- Try for an average of 1-1/2 syllables per word based on a count of at least 100 words (eliminating technical nomenclature)
- Eliminate or "dilute" lengthy words.

Pictorials should be used to introduce key equipment terminology used in prose discussions.

- Present a nomenclature pictorial at the beginning of a section (preferred), or
- Define nomenclature in the text the first time it is used (less preferable)

Layout should enhance reading speed and comprehension.

- Use double column format for prose.
- Arrange graphics and related prose for simultaneous viewing.

GENERAL REWRITE PRACTICES

Rationale

Technical writers employ many more "practices" than are reflected in the preceding discussions of Organization, Technical Communication, and Readability. While it would be impractical to consider *all* practices, some of the more important ones warrant attention, but two important constraints must be emphasized. First, the general rewrite practices in this section are not included as test items because they are not powerful enough to warrant a rewrite decision. The practices should be applied only if a decision to rewrite has been made on the basis of the Organization, Technical Communication, or Readability criteria. The second constraint is that these practices, when applied, cannot be measured with a grade level of readability or comprehension. However, the practices are expected to generally improve user performance and acceptance.

This section presents approximately 50 practices which you should apply when rewriting a manual. For

convenience, this section presents these practices in seven sets; one set for each of seven types of manual content as follows:

1. Nontroubleshooting procedures
2. Proceduralized troubleshooting aids
3. Functional diagrams
4. Schematic and wiring diagrams
5. Tables
6. Graphs
7. Pictorials

Each set is presented in the form of a checklist which contains abbreviated statements of practices relevant to the type of material being considered. Since these practices are reasonably well known, no supporting discussion is provided.

NONTROUBLESHOOTING PROCEDURES PRACTICES

- Do not use paragraph format for presenting instructions.
- Number steps and arrange them in groups of six or less.
- Limit step content to: 25 words or less, two or three thoughts, or two minutes work.
- Provide workstation, locator, and equipment detail pictorials.
- Provide "input" page listing requirements for personnel, test equipment, supplies, and equipment conditions.
- Use second person imperative for narrative instructions.
- Use third person indicative for Notes, Cautions, and Warnings.
- Present Notes, Cautions, and Warnings *before* the relevant steps.
- Use white space, titles, and paragraph format to distinguish Notes, Cautions, and Warnings from instructions.
- Specify follow-on maintenance.

PROCEDURALIZED TROUBLESHOOTING AIDS PRACTICES

- Provide hard copy to facilitate usage at job site.
- Use logic tree or decision table formats to portray branching or multiple alternatives.
- Good troubleshooting format should include:
 - symptom statement
 - logic statement, viz., why this upcoming step
 - abbreviated action statement
 - sequence guidance via branching or parenthetical notes
 - progress statements for each step or interim conclusion
 - tolerance standards
 - conclusion and corrective action.

FUNCTIONAL DIAGRAMS PRACTICES

- Use direction arrows to show flow. Design flow to be left to right and top to bottom.
- Omit detail within maintainable unit.
- Specify signal characteristics/tolerances in pictorial or tabular form.
- Use height to width ratio of two to three for functional flow blocks.
- Provide procedural support on how to troubleshoot complex portions of functional diagram
- Provide hardcopy to facilitate signal tracing.
- Ensure that word labels comply with minimum type size standards.

SCHEMATIC AND WIRING DIAGRAM PRACTICES

- Show piece part detail *only* when replacement is authorized at that level.
- Provide at least 1/8" separation between parallel lines.
- Label points of continuity between multiple page presentations.
- Include superordinate units.
- Provide procedural help for complex portions of wiring and schematic diagrams.
- Ensure that word labels comply with minimum type size standards.
- Provide hard copy to facilitate signal tracing.

TABLES PRACTICES

- Select title to reflect content variables.
- Provide fewer columns than rows.
- Avoid empty rows or columns.
- Specify units in column heads.
- Arrange row entries in groups of six or less.
- Order row entries; alphabetize if necessary.
- Align elements within column and row.
- Do not require interpolation in numerical look-up tables.
- Distinguish multiple elements in a single cell, e.g., type size.
- Show at least 25 percent white space.
- Enclose table in border.

GRAPHS PRACTICES

- Use graphs instead of tables where single or double interpolation is required.
- Use grid interval of 0.3 inches (0.1 inch minimum).
- Use grid lines which are 0.015 to 0.0125 inch wide.
- Orient axes naturally, e.g., altitude on vertical axis.
- Select title to reflect graph variables.
- Enclose graphs in a border.
- Provide instructions and illustrations for using complex graphs.
- Provide a legend for nonstandard symbols.

PICTORIALS PRACTICES

- When supporting procedures, pictorials should progress from contextual to enlargements to exploded views.
- Use pictorials to introduce terminology used in upcoming equipment descriptions.
- Use line drawings emphasizing relevant items rather than faithful physical fidelity.
- Use pictures to portray waveform tolerances.
- Present the technician's view; do not use orientations he can't see.
- Orient viewer by use of direction arrows, e.g., FWD, REAR.
- Use arrows to indicate motion.
- Use arrows and (callouts) to emphasize key points of a drawing.
- Limit callouts to seven or less.
- Number callouts to correspond to instructional steps.

UNCLASSIFIED

SECURITY CLASSIFICATION OF THIS PAGE(When Data Entered)

1. Organization Requirements
2. Technical Communication Requirements
3. Readability Requirements
4. Summary Checklists
5. General Rewrite Practices

The first three sections are developed in the form of tests and criteria to be applied to a technical manuscript. The fourth section is a summary of the first three sections in checklist form. The final section contains a listing of some good technical writing practices.

There are two companion products to the report. The first is a "book plan" which specifies the impact the requirements and criteria will have on an existing maintenance manual. The second is an evaluation plan for verifying the efficacy of the requirements and criteria for improving reading comprehension.

UNCLASSIFIED

SECURITY CLASSIFICATION OF THIS PAGE(When Data Entered)

UNCLASSIFIED

SECURITY CLASSIFICATION OF THIS PAGE (When Data Entered)

| REPORT DOCUMENTATION PAGE | | READ INSTRUCTIONS BEFORE COMPLETING FORM |
|--|-----------------------|---|
| 1. REPORT NUMBER | 2. GOVT ACCESSION NO. | 3. RECIPIENT'S CATALOG NUMBER |
| 4. TITLE (and Subtitle) Requirements and Criteria for Improving Reading Comprehension of Technical Manuals | | 5. TYPE OF REPORT & PERIOD COVERED FINAL |
| 7. AUTHOR(s) Theodore J. Post Harold E. Price | | 6. PERFORMING ORG. REPORT NUMBER N/A |
| 9. PERFORMING ORGANIZATION NAME AND ADDRESS BioTechnology, Inc. 3027 Rosemary Lane Falls Church, Virginia 22042 | | 8. CONTRACT OR GRANT NUMBER(s) N00024-74-C-5426 <i>neu</i> |
| 11. CONTROLLING OFFICE NAME AND ADDRESS | | 10. PROGRAM ELEMENT, PROJECT, TASK AREA & WORK UNIT NUMBERS |
| 14. MONITORING AGENCY NAME & ADDRESS (if different from Controlling Office) Technical Publications Branch, 0463 Naval Sea Systems Command Washington, D.C. | | 12. REPORT DATE November 1974 |
| | | 13. NUMBER OF PAGES 65 |
| | | 15. SECURITY CLASS. (of this report) Unclassified |
| 16. DISTRIBUTION STATEMENT (of this Report) Distribution of This Report is Unlimited | | 15a. DECLASSIFICATION/DOWNGRADING SCHEDULE |
| 17. DISTRIBUTION STATEMENT (of the abstract entered in Block 20, if different from Report) | | |
| 18. SUPPLEMENTARY NOTES | | |
| 19. KEY WORDS (Continue on reverse side if necessary and identify by block number) Readability Maintenance Manuals Comprehension Job Aids Technical Publications Information Presentation Technical Manuals Technical Writing | | |
| 20. ABSTRACT (Continue on reverse side if necessary and identify by block number) A gap exists between the reading comprehension level of technical manuals and the reading abilities of new Navy technicians. This report presents requirements and criteria to be used by technical writers to improve the readability and comprehensibility of their manuscripts. The report is presented in five major sections as follows: | | |

DD FORM 1473
1 JAN 73

EDITION OF 1 NOV 65 IS OBSOLETE
S/N 0102-014-6601

UNCLASSIFIED
SECURITY CLASSIFICATION OF THIS PAGE (When Data Entered)

