

AD-A070 567

GIANNOTTI AND BUCK ASSOCIATES INC RIVERDALE MD  
CRITICAL EVALUATION OF LOW-ENERGY SHIP COLLISION DAMAGE THEORIE--ETC(U)  
JUL 78 P R VAN MATER, J GIANNOTTI, N JONES  
SSC-284

F/G 13/10

DOT-CG-63738-A

NL

UNCLASSIFIED

OF  
AD  
A070567



SSC-284

1

ADA 070 567

# CRITICAL EVALUATION OF LOW-ENERGY SHIP COLLISION-DAMAGE THEORIES AND DESIGN METHODOLOGIES

LEVEL

## VOLUME I: EVALUATION AND RECOMMENDATIONS

DDC FILE COPY



DDC  
RECEIVED  
JUN 28 1979  
C

This document has been approved  
for public release and sale; its  
distribution is unlimited.

SHIP STRUCTURE COMMITTEE  
1979

79 06 27 010

Member Agencies:  
United States Coast Guard  
Naval Sea Systems Command  
Military Sealift Command  
Maritime Administration  
United States Geological Survey  
American Bureau of Shipping



Address Correspondence to:  
Secretary, Ship Structure Committee  
U.S. Coast Guard Headquarters, (G-M/82)  
Washington, D.C. 20590

An Interagency Advisory Committee  
Dedicated to Improving the Structure of Ships

SR-1237  
APRIL 1979

Interest in structural protection from collision, grounding or stranding ranges from nuclear-powered vessel design to minor damage resulting in pollution. The interest involves economics, safety of life and property, and conservation of the environment.

In view of the existence of a body of prior research, the Ship Structure Committee has conducted a project to critically evaluate this prior effort and determine whether at least one of the available design methods or a combination of methods can be used with confidence for minimization of collision damage and protection of the vessel.

This is Volume I of the final report of the project and is being published to assist in developing a rational design approach for reducing low-energy collision effects. Volume II will contain an annotated bibliography.

A handwritten signature in cursive script, appearing to read 'Henry B. Bell'.

Henry B. Bell  
Rear Admiral, U. S. Coast Guard  
Chairman, Ship Structure Committee

SSC-284  
FINAL REPORT  
on  
Project SR-1237  
"Collision Damage and Stranding"

12

CRITICAL EVALUATION OF LOW-ENERGY  
SHIP COLLISION-DAMAGE THEORIES  
AND DESIGN METHODOLOGIES

VOLUME I: EVALUATION AND RECOMMENDATIONS

by

P. R. Van Mater, Jr.  
J. G. Giannotti

GIANNOTTI & BUCK ASSOCIATES, INC.

With contributions by

N. Jones and  
P. Genalis

under

Department of Transportation  
United States Coast Guard  
Contract No. DOT-CG-63738-A

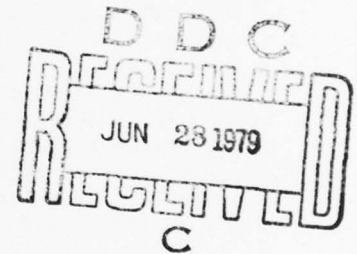

*This document has been approved for public release and  
sale; its distribution is unlimited.*

U. S. Coast Guard Headquarters  
Washington, D.C.  
1979

79 06 27 010

9 / Final report 28 Feb 77 - 28 Jul 78

Technical Report Documentation Page

1. Report No. (18) SSC-284	2. Government Accession No.	3. Recipient's Catalog No. (11)	
4. Title and Subtitle Critical Evaluation of Low-Energy Ship Collision Damage Theories and Design Methodologies. Volume I: Evaluation and Recommendations.		5. Report Date July 1978	
7. Author(s) P.R./Van Mater, Jr., J./Giannotti, N./Jones, P./Genalis		6. Performing Organization Code	
9. Performing Organization Name and Address Giannotti & Buck Associates, Inc. 5711 Sarvis Avenue, Suite 402 Riverdale, Maryland 20840		8. Performing Organization Report No. (13) 9201	
12. Sponsoring Agency Name and Address Commandant (G-FCP-2/71) U. S. Coast Guard 400 Seventh Street, S. W. Washington, D. C.		10. Work Unit No. (TRAIS)	
15. Supplementary Notes Contract monitored by: Ship Research Committee National Academy of Sciences Washington, D. C.		11. Contract or Grant No. (15) DOT-CG-63738-A	
16. Abstract This is Volume I of a two-volume report describing the results of a Ship Structure Committee study aimed at conducting a critical evaluation of low-energy ship collision damage theories and design methodologies. Data sources on ship collision damage are identified including model experiments and full scale information obtained from ship casualty records. The assumptions made by existing theories for analyzing low energy collisions are assessed and the collision energy absorption mechanisms are ranked. A method is proposed for extending Minorsky's original high-energy analysis to the low-energy regime. Recommendations for use of existing methods and for further research are made.		13. Type of Report and Period Covered Technical Report 28/2/77 - 28/7/78	
17. Key Words Ship collisions Structural Analysis Structural Damage Ship Structures Structural Failures		18. Distribution Statement This document has been approved for public release and sale; its distribution is unlimited.	
19. Security Classif. (of this report) Unclassified	20. Security Classif. (of this page) Unclassified	21. No. of Pages 91	22. Price

411 246

5013

SHIP STRUCTURE COMMITTEE

The SHIP STRUCTURE COMMITTEE is constituted to prosecute a research program to improve the hull structures of ships and other marine structures by an extension of knowledge pertaining to design, materials and methods of construction.

RADM H. N. Bell (Chairman)  
Chief, Office of Merchant Marine  
Safety  
U. S. Coast Guard Headquarters

Mr. M. Pitkin  
Assistant Administrator for  
Commercial Development  
Maritime Administration

Mr. P. M. Palermo  
Assistant for Structures  
Naval Ship Engineering Center  
Naval Sea Systems Command

Mr. R. B. Krahl  
Chief, Branch of Marine Oil and  
Gas Operations  
U. S. Geological Survey

Mr. W. N. Hannan  
Vice President  
American Bureau of Shipping

Mr. C. J. Whitestone  
Chief Engineer  
Military Sealift Command

LCDR T. H. Robinson, U. S. Coast Guard (Secretary)

SHIP STRUCTURE SUBCOMMITTEE

The SHIP STRUCTURE SUBCOMMITTEE acts for the Ship Structure Committee on technical matters by providing technical coordination for the determination of goals and objectives of the program, and by evaluating and interpreting the results in terms of structural design, construction and operation.

U. S. COAST GUARD

Cdr. J. C. Card  
Lcdr S. H. Davis  
Capt C. B. Glass  
Dr. W. C. Dietz

MILITARY SEALIFT COMMAND

Mr. T. W. Chapman  
Mr. A. B. Stavovy  
Mr. D. Stein  
Mr. J. Torresen

NAVAL SEA SYSTEMS COMMAND

Mr. R. Chiu  
Mr. R. Johnson  
Mr. G. Sorkin  
Mr. J. B. O'Brien (Contracts Admin.)

AMERICAN BUREAU OF SHIPPING

Dr. H. Y. Jan  
Mr. D. Liu  
Mr. I. L. Stern  
Mr. S. G. Stiansen (Chairman)

MARITIME ADMINISTRATION

Mr. F. J. Dashnaw  
Mr. N. O. Hammer  
Mr. F. Seibold  
Mr. M. Touma

U. S. GEOLOGICAL SURVEY

Mr. R. Ciangerelli  
Mr. J. Gregory

NATIONAL ACADEMY OF SCIENCES  
SHIP RESEARCH COMMITTEE

Mr. O. H. Oakley - Liaison  
Mr. R. W. Rumke - Liaison

INTERNATIONAL SHIP STRUCTURES CONGRESS

Prof. J. H. Evans - Liaison

SOCIETY OF NAVAL ARCHITECTS &  
MARINE ENGINEERS

Mr. A. B. Stavovy - Liaison

AMERICAN IRON & STEEL INSTITUTE

Mr. R. H. Sterne - Liaison

WELDING RESEARCH COUNCIL

Mr. K. H. Koopman - Liaison

STATE UNIV. OF NEW YORK MARITIME COLLEGE

Dr. W. R. Porter - Liaison

U. S. COAST GUARD ACADEMY

Capt W. C. Nolan - Liaison

U. S. NAVAL ACADEMY

Dr. R. Battacharyya - Liaison

U. S. MERCHANT MARINE ACADEMY  
Dr. Chin-Bea Kim - Liaison

Accession For	
NTIS Glaxi	<input checked="" type="checkbox"/>
DDC TAB	<input type="checkbox"/>
Unannounced	<input type="checkbox"/>
Justification	
By	
Distribution/	
Availability Codes	
Dist	Avail and/or special
A	

## METRIC CONVERSION FACTORS

### Approximate Conversions to Metric Measures

Symbol	When You Know	Multiply by	To Find	Symbol
<b>LENGTH</b>				
in	inches	2.5	centimeters	cm
ft	feet	30	centimeters	cm
yd	yards	0.9	meters	m
mi	miles	1.6	kilometers	km
<b>AREA</b>				
in <sup>2</sup>	square inches	6.5	square centimeters	cm <sup>2</sup>
ft <sup>2</sup>	square feet	0.09	square meters	m <sup>2</sup>
yd <sup>2</sup>	square yards	0.8	square meters	m <sup>2</sup>
mi <sup>2</sup>	square miles	2.6	square kilometers	km <sup>2</sup>
	acres	0.4	hectares	ha
<b>MASS (weight)</b>				
oz	ounces	28	grams	g
lb	pounds	0.45	kilograms	kg
	short tons	0.9	tonnes	t
		(2000 lb)		
<b>VOLUME</b>				
1/8 p	teaspoons	5	milliliters	ml
1/4 p	tablespoons	15	milliliters	ml
fl oz	fluid ounces	30	milliliters	ml
c	cups	0.24	liters	l
p	pints	0.47	liters	l
qt	quarts	0.95	liters	l
gal	gallons	3.8	liters	l
ft <sup>3</sup>	cubic feet	0.03	cubic meters	m <sup>3</sup>
yd <sup>3</sup>	cubic yards	0.76	cubic meters	m <sup>3</sup>
<b>TEMPERATURE (exact)</b>				
°F	Fahrenheit temperature	5/9 (then subtracting 32)	Celsius temperature	°C

### Approximate Conversions from Metric Measures

Symbol	When You Know	Multiply by	To Find	Symbol
<b>LENGTH</b>				
mm	millimeters	0.04	inches	in
cm	centimeters	0.4	inches	in
m	meters	3.3	feet	ft
m	meters	1.1	yards	yd
km	kilometers	0.6	miles	mi
<b>AREA</b>				
cm <sup>2</sup>	square centimeters	0.16	square inches	in <sup>2</sup>
m <sup>2</sup>	square meters	1.2	square yards	yd <sup>2</sup>
km <sup>2</sup>	square kilometers	0.4	square miles	mi <sup>2</sup>
ha	hectares (10,000 m <sup>2</sup> )	2.5	acres	ac
<b>MASS (weight)</b>				
g	grams	0.035	ounces	oz
kg	kilograms	2.2	pounds	lb
t	tonnes (1000 kg)	1.1	short tons	st
<b>VOLUME</b>				
ml	milliliters	0.03	fluid ounces	fl oz
l	liters	2.1	pints	p
l	liters	1.06	quarts	qt
l	liters	0.76	gallons	gal
m <sup>3</sup>	cubic meters	35	cubic feet	ft <sup>3</sup>
m <sup>3</sup>	cubic meters	1.3	cubic yards	yd <sup>3</sup>
<b>TEMPERATURE (exact)</b>				
°C	Celsius temperature	9/5 (then add 32)	Fahrenheit temperature	°F

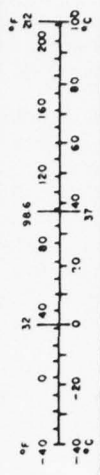
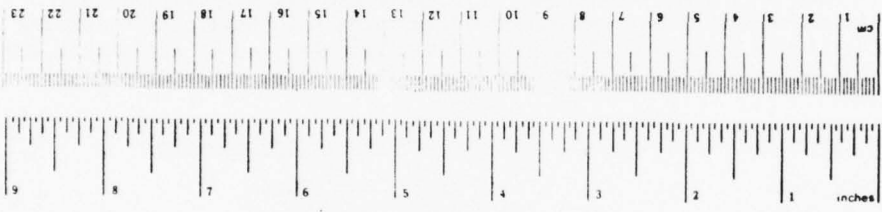

\*1 inch = 2.54 centimeters. For other exact conversions and more detailed tables, see NBS Mon. Publ. 280, Guide to Weights and Measures, Price \$2.25, SO Catalog No. C13.10.286.

TABLE OF CONTENTS

	PAGE
1.0 <u>INTRODUCTION</u> . . . . .	1
2.0 <u>SCOPE AND OBJECTIVES</u> . . . . .	2
3.0 <u>REVIEW OF PAST AND CURRENT WORK IN LOW-ENERGY SHIP COLLISION DAMAGE</u> . . . . .	3-1
3.1 GENERAL . . . . .	3-1
3.2 SUMMARY OF EXPERIMENTAL AND FULL-SCALE SHIP COLLISION DATA . . . . .	3-1
3.3 CRITICAL REVIEW OF EXISTING METHODS OF ANALYSIS . . . . .	3-9
4.0 <u>ASSESSMENT OF ADEQUACY AND VALIDITY OF THE EXISTING LOW-ENERGY COLLISION DAMAGE THEORIES AND DESIGN METHODOLOGIES</u> . . . . .	4-1
4.1 VALIDITY OF THE ASSUMPTIONS MADE IN THE ROSENBLATT METHOD . . . . .	4-2
4.2 APPLICABILITY OF THE LOW-ENERGY COLLISION DAMAGE THEORIES AND DESIGN METHODOLOGIES . . . . .	4-6
4.3 SENSITIVITY AND RANKING OF SHIP COLLISION ENERGY ABSORPTION MECHANISMS . . . . .	4-8
5.0 <u>CONCLUSIONS AND RECOMMENDATIONS</u> . . . . .	5-1
5.1 GENERAL . . . . .	5-1
5.2 CONCLUSIONS . . . . .	5-1
5.3 RECOMMENDATIONS . . . . .	5-4

REFERENCES

APPENDICES

APPENDIX A - A SUMMARY OF GKSS COLLISION WORK

APPENDIX B - STATUS OF THE DEVELOPMENT OF THE MATHEMATICAL MODEL OF STRUCTURAL RESPONSE OF ENERGY RESISTING COLLISION BARRIERS AS OF DECEMBER 1977

APPENDIX C - EXTENSION OF MINORSKY'S ORIGINAL WORK TO THE LOW-  
ENERGY SHIP COLLISION REGION

APPENDIX D - CRITICAL REVIEW AND ASSESSMENT OF THE ASSUMPTIONS  
IN THE ROSENBLATT METHOD BY PROFESSOR NORMAN JONES

## 1.0 INTRODUCTION

The bulk of the past and current research work in the field of ship collision damage and protection has been devoted to the design of the reactor and nuclear spaces of nuclear powered ships. On the other hand relatively little attention has been paid to the development of methodologies for designing hull structures which can sustain the impact induced by a striking vessel without rupturing. This is particularly important in the case of oil tankers, LNG and LPG carriers or other similar types of ships.

The problem, of course, is not a simple one. In the case of a nuclear ship the concern is to protect the nuclear reactor while a LNG carrier needs similar protection for its cargo tanks. In both cases the requirement for structural design criteria is of a local nature. If on the other hand the goal is to provide collision protection to an oil tanker then one must do so for the entire length of the hull. Clearly this requirement restricts the feasibility of providing protection to the case of low-energy collisions. These are collisions which take place at relatively low speeds where the shell of the struck ship is deformed but not ruptured. High-energy collisions, on the other hand, are associated with high impact speeds and tend to cause rupture. The latter type calls for structural protection for selected portions or spaces within the hull which require massive or highly complex and expensive structures to design and build. This is the case of the so called impenetrable barrier which has been developed in Germany for use in the design of nuclear powered vessels.

Research work in the area of low and high-energy collisions has been conducted in Germany, Japan, Italy and in the United States. These efforts have included both analytical and experimental studies on model and full-scale structural members. In practically all cases simplifying assumptions have been made which limit the range of validity of the results to specific conditions of collision and/or structural designs. These assumptions have been necessary if one is to tackle the highly complicated structural loading and response problem which is created by the collision of a ship against another stationary or moving ship. Such problems are associated, among other things, with attempting to define the added mass coefficient for the struck ship; calculating the degree of energy absorption due to the rigid body translation and rotation of the colliding ships; or deriving valid scaling laws for extrapolating model-scale experimental collision data to full-scale design conditions.

In view of the above comments and the current status of ship collision research work, the Ship Structure Committee has recognized that while the protection of the reactor space of a nuclear powered vessel against high-energy type collisions appears to be near solution, the protection of hazardous and possible polluting cargoes now emerges as a structural problem of major importance. The major concern is with LNG and LPG carriers. A comprehensive collision and stranding research program

carried out with these carriers in mind may be expected to produce information applicable to ships in general.

The work described herein constitutes the first step towards the development of reliable methods for designing hull structures to resist low-energy collisions. The state-of-the-art is defined and the available methodologies are assessed with respect to their assumptions and limitations. The study concludes with a set of recommendations for improving and/or extending the range of validity of these methodologies.

## 2.0 SCOPE AND OBJECTIVES

The Ship Structure Committee long-range collision/stranding plan is shown in Figure 1. In developing the plan, the SSC has classified ship collisions as being of low and high-energy types, whereby the latter causes a rupture of the shell and the former deforms it without rupture.

The overall objective of the study described in this report was to conduct a critical evaluation of all prior low-energy collision work and the determination, in each case, of its validity and range of application. Deficiencies associated with analytical methods and theories were to be identified wherever they may exist. In the experimental arena all tests conducted up to the present time were to be closely checked for relevance and completeness. The ultimate objective was to determine whether or not one of the existing methods or a combination of methods can be used with confidence as the basis of a design methodology for minimizing collision damage and providing protection to the ship's cargo.

Although the main thrust of this study was aimed at the low-energy collision work it was decided that it would be to the advantage of the project to pay some attention to the work conducted in the high-energy collision domain since it is the natural extension of the low-energy collision phenomenon. The rationale here was that the mechanisms of collision as well as the assumptions and simplifications made in the low and high-energy collision analytical and experimental efforts could have a few things in common.

Three tasks were carried out in this project. These were:

### TASK I - LITERATURE SEARCH AND REVIEW

The pertinent literature published both in the U. S. and abroad was reviewed. The existing methods of structural analysis applicable to the development of low-energy collision damage methodologies were critically reviewed. Postulated mechanisms for transferring and dissipating collision energy were identified and ranked. Volume II of this report presents the results of the literature search including an annotated bibliography and list of references.

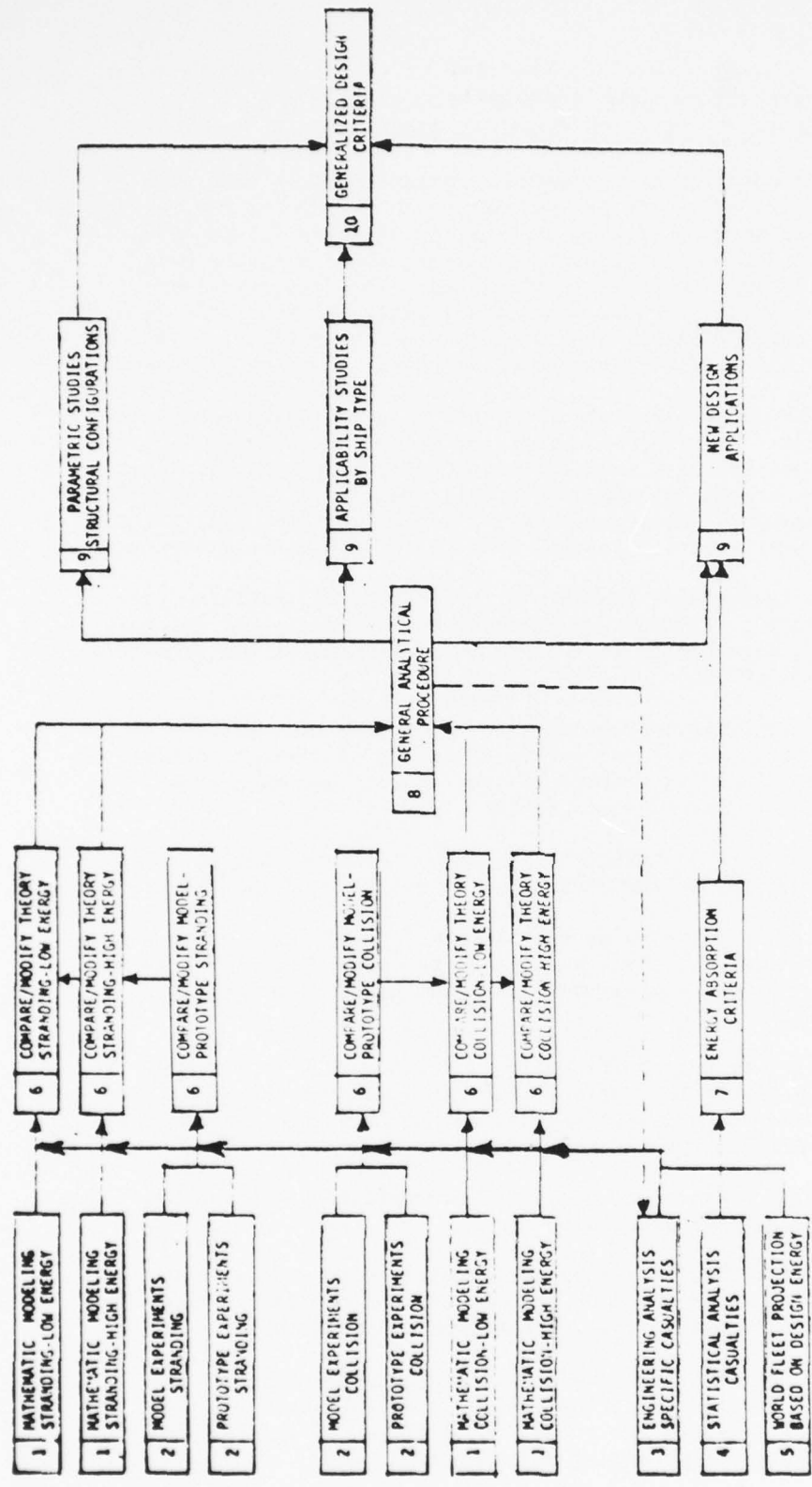

THE NUMBER IN EACH BOX REFERS TO CONDENSED PROJECT DESCRIPTIONS PROVIDED ON THE FOLLOWING PAGE

Figure 1 FLOW DIAGRAM FOR LONG-RANGE COLLISION/STRANDING RESEARCH PLAN

Figure 1 (cont.)

DESCRIPTION OF ITEMS SHOWN IN FLOW DIAGRAM FOR  
LONG-RANGE COLLISION/STRANDING RESEARCH PLAN

1. Mathematical modeling of Collision or Stranding involving high energy (rupture of shell) or low energy (shell deforms but remains intact). Projects to include application of loads, rigid body mechanics, hydrodynamic response including added mass and hull static and dynamic response (deflections, vibration, fracture), structural framing systems, materials (steel, concrete, aluminum, and hybrid combinations), absolute and relative motions of impacting vessels (or grounding surfaces), typical grounding surfaces.
2. Model and Prototype experiments for high and low-energy collisions or strandings. Testing parameters for prototype and model testing to include critical examination of effects of scaling, model fabrication techniques, model materials, entrained water, relative motions, time durations, ideal versus available testing facilities, and environmental considerations when testing in prototype scale.
3. Engineering Analysis of Representative Casualties involving high and low-energy collisions and strandings with particular emphasis on compiling data needed to analyze the mechanics of the structural response and failure.
4. Statistical Analysis of Collision and Stranding Casualties - World-wide statistical survey to provide estimates of risk of collision and stranding based on service, route, season, and such other factors that are deemed appropriate.
5. World Fleet Projections Based on probable Collision Energy (Displacement Tonnage and Design Speed) and Bow Configurations.
6. Compare and Modify Theory or Experiments for Collision or Stranding (High or Low energy). Evaluate errors in each, estimate validity, and suggest changes to improve either theory or experimental techniques.
7. Data Analysis for Energy Absorption Criteria - Develop energy-absorption criteria for various ship types so that the ship can expect to have the critical barrier remain intact in -- % of the expected collisions/groundings.
8. General Analytic Procedure based on Theoretical Studies as modified by Experimental Studies.
9. Specific Design Studies incorporating various structural configurations, differences based on ship types, and new design applications such as frangible bows, protective barriers, etc.
10. Generalized Design Criteria - combine results from the various prerequisite studies to define design criteria, including consideration of geometry and structural design, for low- and high-energy casualty and stranding protection.

TASK II - ASSESSMENT OF THE ADEQUACY AND VALIDITY OF THE EXISTING  
LOW-ENERGY COLLISION DAMAGE THEORIES AND DESIGN METHODOLOGIES

The initial conditions of the collisions postulated by the previous investigators and the valid ranges of the parameters of these collisions were determined.

TASK III - RECOMMENDATIONS REGARDING THE USE OF EXISTING METHODS AND  
FUTURE RESEARCH

Recommendations are made regarding the use and limitations of the reviewed methods in the structural design of ship hulls. It is indicated how these methods may be improved and their ranges of validity extended. A plan to accomplish these objectives has been prepared.

### 3.0 REVIEW OF PAST AND CURRENT WORK IN LOW-ENERGY SHIP COLLISION DAMAGE

#### 3.1 GENERAL

Volume II of this report contains an overall statement of the state-of-the-art in ship collision work in general. Also an annotated bibliography and an extensive list of references are also included in the same volume. In this section close attention is paid to the work which is of specific interest to the objective of this project, that is, to critically evaluate existing methods of structural analyses applicable to the development of low-energy collision damage theories and design methodologies.

#### 3.2 SUMMARY OF EXPERIMENTAL AND FULL-SCALE LOW-ENERGY SHIP COLLISION DATA

##### A. Experimental Data

The experimental work on models of structural members and/or sections of different types of hulls comes basically from four sources. These are:

1. Tests conducted by U. S. Steel Research Laboratory in cooperation with M. Rosenblatt & Son, Inc., under the sponsorship of the U. S. Coast Guard. Ten tests were conducted, each consisting of the application of a concentrated static lateral load on a reduced scale model (approximately 1:5 scale) of a representative portion of the side of a typical longitudinally framed tanker. Descriptions of these tests and results are presented in References (1) and (2).
2. Tests conducted in Japan and presented by Akita, et al, (3). A summary of these tests is given in Table 1.

-----  
Table 1 - Summary of Japanese Experiments

<u>Type of Test</u>	<u>Performing Organization</u>
Wedge load tests of flat plates	University of Tokyo
Model tests of explosion protective structures	Mitsubishi Heavy Industries, Ltd.
Tests on the effects of stem angle	Hitachi Shipbuilding & Engineering Co., Ltd.
Experiments on oblique collision	Kawasaki Heavy Industries, Ltd. and Mitsui Shipbuilding & Engineering Co., Ltd.
Tests on the effects of stem stiffness of striking vessels	Ishikawajima-Harima Heavy Industries Co., Ltd.
Dynamic fracture tests	Ship Research Institute

3. Tests conducted in Italy under the direction of Professor F. Spinelli of the University of Naples. A total of 24 tests were conducted on collisions of various configurations. The results are reported by Belli (4).
4. Tests conducted in Germany under the supervision of GKSS, at a test facility constructed at the Deutsche Werft Shipyard in Hamburg. Although these tests were aimed mainly at the high-energy collision problem it is of interest to describe them here in that some of the experimental observations could be helpful to the analysis of low-energy collisions.

The GKSS tests consisted of releasing a ship-bow model on a carriage to roll down a ramp and impact against a side model mounted on a long restrained beam simulating the ship's hull girder. From 1967 to 1975 twelve tests were conducted. The first three of these tests were on energy absorbing barriers for the reactor compartment of the nuclear ship OTTO HAHN. The remaining tests were on a barrier of the energy resisting type designed for a second generation of nuclear ships. The barrier consists of an "egg crate" grillage of horizontal and vertical webs. In general the tests successfully demonstrated the ability of this type of structure to avoid rupture and penetration of the nuclear compartment by the various types of bows tested. The chief limitation is the added weight and cost penalty. A thirteenth test using an icebreaker bow was not conducted due to lack of funds. The shipyard has subsequently been sold and converted to other service, although the facility could still be made available if new funding became available.

A limitation of the Deutsche Werft tests is that they were conducted by shipyard personnel and were generally inadequately instrumented. While the gross effects were well documented histories of impact force, local strain and deformations were not obtained. This makes correlation with analytical models difficult. A further limitation is that the rigid attachment of the supporting beam precluded the reflection of time-dependent added mass effects in the collision interaction.

GKSS has also sponsored impact tests on models of various scales of simple beams, plates, and plate-frame combinations carried out at the University of Hamburg to determine scale effects in impact testing. Woisin of GKSS has reported the results in references (5), (6), and (7). Figure 1 shows photographs of the test setup before and after a collision test.

The German tests represent the most complete body of experimental information available. Whether the unfortunate lack of load data will preclude its use for low-energy collision work remains to be seen. A comprehensive summary of the German work has been included as Appendix A to this volume of the report.

Other experimental work of interest to the problem of low-energy collisions are the numerous tests of dynamically loaded structural members conducted at institutions such as M.I.T. and Brown University. The results of these tests have been used to develop plastic theories for the prediction of permanent damage induced on structures due to impulsive loads. This work has been summarized recently for ship structural design applications by Jones (8). Another recent set of tests conducted on scale models of ships colliding are those sponsored by NMRC and conducted at the University of Rhode Island, Department of Ocean Engineering. Results of these tests are reported in reference (9).

#### B. Full-Scale Data

The full-scale data available on ship collision damage comes as a result of actual collisions at sea. The sources of data are U.S. Coast Guard ship casualty reports and/or inspection reports prepared by various groups who have been funded to study the ship collision problem. The following is a summary of the principal efforts which have been conducted up to date in an attempt to develop useful ship collision data banks.

1. In 1961 Gibbs & Cox, Inc., published a design criteria manual (10). The manual includes the results of a statistical analysis of a large number of collisions of 1950's vintage. Eight cases of ship damage were analyzed based on photographic evidence and U. S. Salvage Association Surveyor's reports. Most of the collisions considered are of the high-energy type.
2. The classical paper by Minorsky (11) gives relevant data on ship collisions used for his analysis. Data were provided for 50 collisions by the U. S. Coast Guard. The data included speeds, angle of encounter, displacements, drafts, and extent and location of damage. To these were added the particulars of the STOCKHOLM-ANDREA DORIA collision and those of two other collisions where in each case a tanker was struck by a passenger ship at high speed. A total of 18 low-energy collision cases were identified.

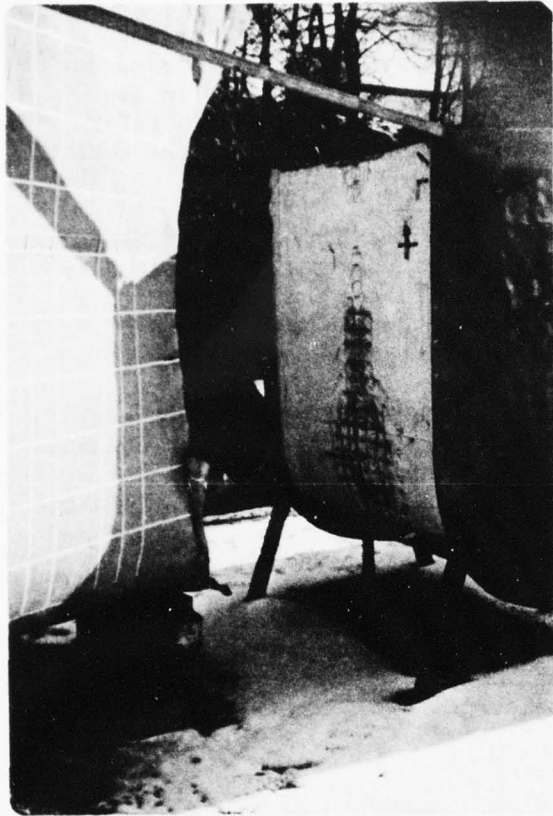

Figure 1(a)  
Models of Striking Bow  
and the Barrier of a Struck  
Ship Before a GKSS Collision  
Test

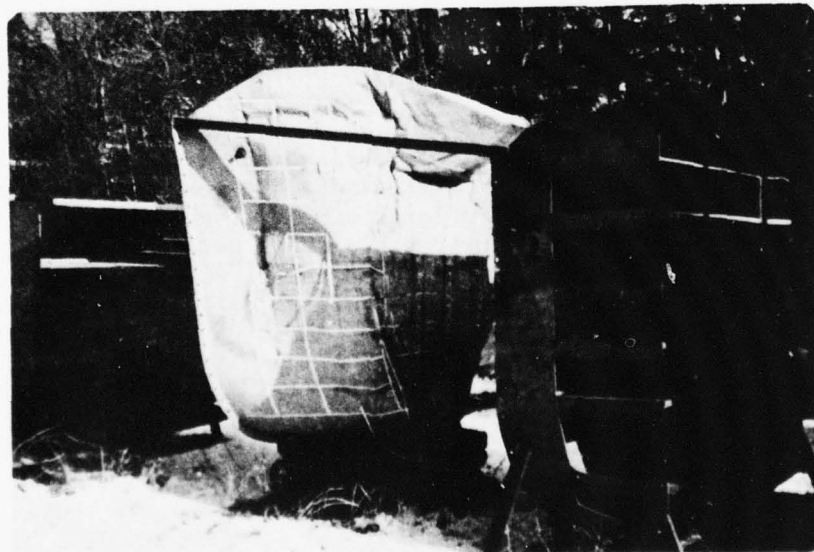

Figure 1(b) Models of Striking Bow and the Barrier  
of a Struck Ship After a GKSS Collision Test

3. In 1973, a U. S. Coast Guard report (12) published a re-report on tanker groundings and collisions. Casualty data were taken from two sources: IMCO Damage Cards submitted by fourteen countries from 1964 to 1966 and U. S. Coast Guard data dated April 1958. Of the over one thousand cases of groundings and collisions 51 collision cases and 13 groundings were found to be amenable to analysis. The criteria used for selection were as follows:

- (a) The struck vessel was a tanker.
- (b) The casualty was a two-ship collision or a vessel grounding.
- (c) Details of the casualty—depth of penetration, geographical location, angle of collision, speeds of all vessels involved—were stated.
- (d) Details of the vessels—length, beam, draft—were stated.

4. In 1975, George G. Sharp, Inc., published a report (13) on ship casualties based on 127 monthly casualty return sheets for the period 1964-1974 from the Liverpool Underwriters Association. Ships over 2,000 gross tons world wide were considered with special interest in casualties derived from collisions and more specifically for three proposed nuclear ship routes. During the period there were 831 ships involved in collisions and 850 in groundings.

5. Also in 1975, M. Rosenblatt, Inc., prepared a report for the U. S. Coast Guard (2) which presents the results of collision inspections for six cases. None of the cases involved an ocean tanker with minor or moderate damage and none included damage of horizontally stiffened web frames which were of particular interest to their work. The following are the six collision cases reported on with an indication given in each case as to whether or not rupture of the shell took place.

<u>Struck Ship</u>	<u>Rupture?</u>
1. Longitudinally frames single hull barge (struck concrete dolphin)	Yes
2. Longitudinally framed double-hull barge (struck piers on dam)	Yes
3. Transversely framed cargo ship(AEGEAN SEA struck by cargo ship C. E. DANT)	Yes
4. Longitudinally framed single-hull barge (struck by tug boat)	No
5. Longitudinally framed double-hull barge (struck pier of bridge)	No
6. Longitudinally framed oil tanker (ESSO BRUSSELS struck by containership C. V. SEAWITCH)	Yes

Analyses of the results of the six ships' collision inspection cases led to the following generalized conclusions (2):

- (1) The bow of the striking ship distorts significantly only if it encounters relatively stiff horizontal resistance at a deck or bilge.
  - (2) The longitudinal extent of damage is the same for the deck, shell plate, and all damaged longitudinals.
  - (3) The energy-absorption capacity of a longitudinally framed ship is generally greater than that of a comparable transversely framed ship.
  - (4) The longitudinal extent of damage is likely to be restricted between the transverse bulkheads and/or strong web frames.
  - (5) The deck and bilge area are "hard points" in resisting side incursion unless the striking bow directly bears against them.
  - (6) The relative location of strike to a transverse bulkhead has a significant effect on energy absorption.
  - (7) For a longitudinally stiffened hull, the collision energy is primarily absorbed by membrane tension in the side shell plate and longitudinal stiffeners.
  - (8) For a double-skin struck ship, web plates are more effective than web trusses for causing the two skins to distort in unison.
  - (9) In an oblique collision, the angle of collision remains constant throughout the collision.
  - (10) For oblique collisions, plastic membrane-tension strains occur in the portion of hull behind the strike.
  - (11) The damaged deck forms a series of small-pitch accordian folds extending in the longitudinal direction.
6. As part of the project reported here the U. S. Coast Guard Casualty Records were searched for the period 1972-1976 in order to identify a collision case to test the validity of the methodologies being evaluated. The sort criteria inputted into the U.S.C.G. data base computer program was:
- (a) Cargo ships and tankers.

- (b) FY 1972-1976.
- (c) Collision cases only.
- (d) Damage range \$5,000-\$100,000.  
Damage range \$100,000-\$200,000.

The same data base has been searched previously for the period 1969-1975 and damage range above \$200,000. Most of these cases involved rupture and were therefore not appropriate for the purposes of this study.

The selection criteria for a suitable case were the following:

- (a) No rupture in struck ship.
- (b) Recent case preferred.
- (c) Crossing situation preferred.
- (d) Longitudinally framed struck ship.
- (e) Good definition of speeds and movements.
- (f) Photographs and good damage description needed.
- (g) Struck ship should be of U. S. Registry.

The first run (\$5K-\$100K) produced 583 cases while the second run (\$100K-\$200K) yielded 15 cases. The microfilm records of these casualty reports were then examined to isolate those candidates which met the selection criteria. Most cases could be discarded immediately as inappropriate. A few were identified for further review and are summarized in Table 2. In the final analysis there were no cases which had sufficiently well defined data together with an indentation large enough to be of interest but without rupture.

A second collision data search was performed by contacting the Naval Safety Center in Norfolk, Virginia, where the records of U. S. Navy ship collisions are kept. Again the purpose was to identify possible U. S. Navy collisions in which information exists in sufficient detail to be used as a basis for comparison of actual energy absorption with those predicted analytically. Collision reports on 130 collisions involving U. S. Navy ships were obtained and the result was similar to the case of the U. S. Coast Guard casualty record search. There were really no cases which were of sufficient interest to justify the further

Table 2 - Summary of Ship Collision Cases Selected for Review  
Based on USCG Casualty Records for the Period 1972-1976

SHIP_A	struck	SHIP_B	LOCATION	DATE	USCG CASE NO.	COLLISION ANGLE/ SPEED	DAMAGE
Reg. Type G. T. Length	SS TRANSCAMPAIN U. S. Container Ship 7674 524'	SS PERSEPOLIS Greek Tanker 3346 734'	San Francisco Bay	18 NOV 76	21488	90° 3-4 kts.	Bow of TRANSCAMPAIN badly crushed. Damage to PERSEPOLIS not known.
Reg. Type G. T. Length	SS RHPIN N. German Container Ship 17902 610'	SS C.V. LIGHTNING U. S. Container Ship 17902 610'	Falinstowe, Harbor England	21 SEP 72	30464	?	Plating set in. Frames and Bulkhead buckled on LIGHTNING. Damage to RHPIN not known.
Reg. Type G. T. Length	M/V MONALA U. S. Tug 98 75'	M/T USCG TRANSASIA Philippine Tanker 3236 311'	Apra Harbor, Guam	30 NOV 72	31219	135° ?	TRANSASIA had 5" dent approximately 72 sq. ft. of plating. IMO Cargo TE 6. No damage to MONALA.
Reg. Type G. T. Length	M/V GRANPIUS U. S. Tug 187 100'	SS LOUISE LYKES U. S. Gen. Cargo 10934 540'	Galveston Harbor, Texas	21 MAR 73	37094	?	2" dent in shell plating of LOUISE LYKES. Two frames distorted. No damage to GRANPIUS.
Reg. Type G. T. Length	SS MARYLAND TRADER U. S. Jumbo T-2 Tanker 12,619 572'	WORLD BRIDGESTONE Panamanian LPG Tanker 36,536 660'	Northern Coast of Sumatra	28 MAR 73	32344	35°/77	MARYLAND TRADER's bow buckled aft to chain locker. Damage to WORLD BRIDGESTONE not known.
Reg. Type G. T. Length	SS MOBIL CHICAGO U. S. Tanker 20,295 268'	SS PUERTO RIGAN U. S. Tanker 20,295 660'	Kill Van Kull, Bayonne, New Jersey	9 DEC 74	52363	7/77	Hull of PUERTO RIGAN set in about 6" for 2' x 2' area and set in 3" for 5' x 15' area.
Reg. Type G. T. Length	M/V BANCAROO U. S. Tug 120 65'	SS AMERICAN BEAR U. S. Bulk Carrier 12,003 635'	Mississippi River, New Orleans, La.	20 JAN 75	61586	60°/70°/71	Indentation in AMERICAN BEAR, Port side, PFS 1654 - 167, 11" deep, 3' x 4'.

expense of an investigation which would still have a strong possibility of being fruitless. Three lessons were learned from this exercise:

- (1) It should not be done again.
- (2) In order to obtain good full-scale collision data it probably will be necessary to design and conduct a set of collision experiments between two existing ships. Such an experiment will be extremely expensive and will require thorough planning and careful execution to obtain meaningful results. The possible exception here would be an on-site inspection of a "clean" collision as discussed below.
- (3) There is a vast difference between the real collision world and the world of idealized analytical models.

In addition to the sources of information indicated here there are other possibilities which could be explored. These are the following:

- (a) Under contract with the U. S. Salvage Association the Coast Guard maintains a computerized data base of that organization's damage surveys. It is believed that this data base would contain much useful structural information, but unfortunately this data is held to be proprietary by the Coast Guard and is not available to us.
- (b) U. S. Salvage Association and American Bureau of Shipping survey reports will contain in many cases the information we need but again the information is held as proprietary to their clients.
- (c) IMCO Damage Cards were submitted by the various members of IMCO during the period 1964-66 and provide a good source of statistical information on collisions but generally inadequate structural information.
- (d) Solicitation to individual ship owners could produce release of survey reports and photographs, if all litigation on the damage has been completed.
- (e) On-site inspections of collision damages by an inspection team specifically oriented to examine the damage from an analytical point-of-view offers the most economical data source, but a large element of luck is required to find a "clean" accurately documented collision.

### 3.3 CRITICAL REVIEW OF EXISTING METHODS OF ANALYSIS

The state-of-the-art in ship collision research work has been summarized in Volume II of this report. Furthermore an annotated bibliography of the key publications has been included in the same volume along with an extensive list of other relevant documents.

In order to avoid repetition this section is devoted strictly to critically reviewed methods and experimental results which are of interest to the low-energy collision problem. In addition, consideration was also given to high-energy collision work which could have applications in the low-energy regime.

### 3.3.1 M. Rosenblatt & Son, Inc. Work

M. Rosenblatt & Son collaborating with U. S. Steel Corporation conducted a series of studies during the period 1971-1975 sponsored by the Coast Guard intended to develop a methodology for the analysis of minor collisions in which a tanker was the struck ship. Table 3 gives a summary of the studies in chronological order. The method is summarized in reference (1) which outlines the theory, contains a computational procedure primer, applies the method to several collision cases and to the evaluation of the protective capability of an LNG carrier and examines the potential of several structural schemes intended to enhance collision protection. The analytical procedure is simplistic in its origin but complex in its application to a given collision situation. An array of assumptions are involved, perhaps the most sensitive of which are that the bow of the striking ship is rigid, that the bottom of the ship, the bilge strake, and the transverse bulkheads do not buckle, yield, or rupture, and that the bow of the striking ship does not produce tearing, cutting or punch shearing in the side of the struck ship. The Rosenblatt work is the most directly relevant work on the low-energy collision problem but the impact of the assumptions and the suitability of the overall procedure will be evaluated in subsequent sections.

---

Table 3 - Summary of M. Rosenblatt & Son, Inc. Work

1. December 1975, "Tanker Structural Analysis for Minor Collisions," USCG Rept, CG-D-72-76, includes:
  - Part I - Tanker Structural Analysis for Minor Collisions
  - Part II - Tanker Structural Analysis Procedure Primer
  - Part III - Tanker Structural Analysis Collision Reports
  - Part IV - Evaluation of LNG Ship Structure in Collision
  - Part V - Non-Standard Structural Schemes for Increased Collision Resistance of Tankers
2. November 1974, "Tanker Structural Analysis for Minor Collisions," J. F. McDermott, R. G. Kline, E. L. Jones, Jr., N. M. Maniar, W. P. Chiang, SNAME 1974
3. November 1973, "Evaluation of Tanker Structure in Collision," (with U. S. Steel Corp.) Rpt. 2087-15.
4. April 1972, "Tanker Structural Evaluation," (with U. S. Steel Corp.) Rpt. 2087-15.

### 3.3.2 Hydronautics, Inc. Work

Dr. Pin Yu Chang of Hydronautics, Inc., in collaboration with Dr. Paris Genalis, has developed a finite-element model for an energy-resisting barrier developed by GKSS to predict the elasto-plastic response to "known" input dynamic loads. Since loading pressures were not measured in the GKSS tests the input loads used in the program are based on estimates which make firm correlation with GKSS data difficult.

Professor Reckling of the University of Berlin had developed but not perfected a method for predicting the loads induced on a GKSS-type barrier in a collision with a cylindrical blunt bow. Dr. Genalis, as a consultant to G. G. Sharp under MarAd sponsorship, reanalyzed and expanded this method. V. U. Minorsky of G. G. Sharp then applied this method to predict the loads for one GKSS test. The predicted loads agree within 15% with rough values inferred from GKSS measurements. An alternative method for load prediction is also under investigation. It is expected that when the load-prediction method is finalized the finite-element response model will be re-run with a new set of loads.

Potentially the finite-element approach is a much more powerful and flexible tool than the method used in the Rosenblatt series, but due to the complexity the cost is high. It will not be suitable for use as a routine design tool whereas the Rosenblatt method, perhaps at a later stage of evolution, would. The finite-element model could be used for parametric studies to develop design criteria, or perhaps in the design of special structures such as nuclear plant barriers. A full report on the status of this tool is contained in Appendix B of this volume.

### 3.3.3 Japanese Work

Akita, et al, Reference (3), have reported on collision research in Japan. Interest in the problem, as in the case of GKSS, stemmed from interest in nuclear-powered ships as far back as 1958. Experiments were conducted as early as 1963 with the greatest activity occurring during the 1966-1969 time frame. Both static and dynamic tests were conducted on small, simplified, transversely framed box-like structures. Based on the experiments various relations were developed which described the dynamics of the collision process. Although the conclusions drawn from these studies are of interest the data are suspect due to the size of the models used. On this basis, further exploration of this data source will not be pursued.

### 3.3.4 Italian Work

During the mid-sixties the Italians, principally under the direction of Professor F. Spinelli of the University of Naples,

conducted a total of 24 tests on collisions of various configurations. Results are reported by Belli, reference (4) (in Italian), together with an analytical treatment. The experiments dealt with high-energy collisions on energy absorbing barriers. Hydrodynamic added mass effects were simulated by attaching a longitudinal flat plate to the keel of the struck model and immersing this plate in a small basin of water. The test technique has been much criticized and the data are generally regarded as not suitable for making full-scale inferences. Again, the Italian work, although it makes interesting background reading, does not appear suitable for application to low-energy analysis.

### 3.3.5 German Work

The work which has been conducted in Germany, mainly at GKSS, is in high-energy collisions. The tests which have been conducted up to the present time have been described earlier in this section. Current work including analysis and experimentation is discussed and reviewed in detail in Appendix A of this volume.

### 3.3.6 Gibbs & Cox Design Manual

At the time of the design of the N. S. SAVANNAH in the late fifties by G. G. Sharp, Inc., an independent study at Gibbs & Cox was funded by MarAd. The product of this study was a design criteria manual for nuclear-powered ships, reference (10). The study, which dealt with a variety of aspects of nuclear ship design also treated the collision barrier problem. Both absorbent and resistant barriers were discussed. A statistical analysis of a large number of collisions of 1950's vintage was made. Eight cases of ship damage were analyzed based on photographic evidence and U. S. Salvage Association Surveyors' Reports. Based on these analyses the report concludes that for conventional ship structures about 75% of the total energy transfer in a collision goes into struck ship damage and about 25% goes into damaging the bow of the striking ship. The best correlation for energy absorption was found to be based on the volume of steel structure demolished. No rules were proposed for the design of either absorbent or resistant barriers.

This comprehensive but generally overlooked work contains many interesting features but since it deals with high-energy collisions here again there appears to be little information that we can use directly.

### 3.3.7 Selected Methods for Further Evaluation

Based on the review of the ship collision work discussed above, it became quite clear that there are really only two existing methodologies which are available for low-energy collision analysis. These are the Rosenblatt method and the finite-

element method. Both of these are subjects of Section 4.0. However, as a result of the various works reviewed in this study the possibility of developing a third method surfaced. This involves extending the classic work conducted by Minorsky (11) on high-energy collisions to the low-energy area. This also is a subject of Section 4.0.

#### 4.0 ASSESSMENT OF ADEQUACY AND VALIDITY OF THE EXISTING LOW-ENERGY COLLISION DAMAGE THEORIES AND DESIGN METHODOLOGIES

As indicated in Section 3.0 there are really only two existing methodologies which are available for low-energy collision analysis. These are the Rosenblatt method and the finite-element method. A third possibility which has been initially developed as a result of this study is the extension of Minorsky's original work.

The Rosenblatt method is structured on very basic concepts of plastic analysis coupled with a rather clever splicing of empirical and experimental information. It inevitably becomes somewhat complicated in application to a given structure, but still, with some experience an analyst could complete an analysis of the energy a given ship structure could absorb in a week or two. The method is also suitable for development into a computer program although frequent usage would be required to justify development costs.

Most of the assumptions involved in the method are conservative in nature. Thus, for a collision that closely approximated the scenario assumed in the method, the energy absorbed by the structure would probably be conservatively predicted. The problem is that the likelihood of encountering departures from such a scenario is quite high. In particular if tearing or punching through of the side structure is involved, as it oftentimes is, then some variable amount of membrane-tension energy-absorption capability included in the methodology would not, in fact, be available. Thus for most realistic collision cases the ship side structure cannot be expected to absorb the amount of energy predicted by the method.

The method is advertised very honestly by its authors as a development tool which needs further work before application as a design tool. It appears that the improvements that could be made to the method would have a minor rather than major effect. In the present study the matter of whether a criterion could be incorporated that would reflect the occurrence of dynamic fracture has been examined. Such predictions require a very detailed knowledge of the state of stress which exists in the shell plating. Knowledge of such a micro-level state of stress is precluded by the very nature of the Rosenblatt method and thus inclusion of such a tearing criterion would not be possible.

The finite-element method is the other existing methodology which can be used for low-energy collision analyses. Such work is currently being carried out by Dr. Pin Yu Chang of Hydronautics, Inc., who has been working on a hindcast of one of the German GKSS ship-collision experiments under MarAd sponsorship. While the German tests were a great success as visual demonstrations, the quality of the instrumentation left much to be desired and in particular the loads which occurred during impact were not well measured but had to be inferred using acceleration measurements. Using methods proposed by Reckling and Girard, Genalis and Minorsky have made hindcasts of the loads imparted to the side shell of the GKSS model by the test bow as it crushed

during impact. These results have shown encouraging agreement with the observed data, but in view of the doubtful character of this data, conclusive validation of Chang's work cannot be expected.

Inherently, the finite-element approach is the most accurate analytical tool available and is capable of reflecting dynamic effects, and even dynamic fracture, if expense is no object. To extend Chang's present work to a more general case would require analysis of both striking bow and struck side shell and a method for matching loads and damage on each. This is an extremely complicated and expensive proposition. It is not hard to visualize \$500K in further development costs to produce a working product and thereafter perhaps \$10K - \$20K per application.

There is one further possibility which has surfaced during the course of this study. It is the extension of Minorsky's classic work on high-energy collisions to the low-energy area. Minorsky found considerable scatter in the low-energy collisions which he studied, but it is likely that this was due to the quality of his data rather than the nature of the processes involved. As an input to this study, Professor Norman Jones has looked at the possibility of extending the Minorsky method to the low-energy region. He examined the plastic behavior of a fully encastered, centrally-loaded rectangular bar and by means of a rather clever transformation has converted this to Minorsky's  $E_T$  vs.  $R_T$  format. Jones' analysis shows that the plastic behavior of this simple model follows a line close to and parallel to Minorsky's high-energy line. Jones' analysis was then extended to variable load location. The inference of this is that hope is not lost for the extension of this simple method into the low-energy region. Detailed descriptions of these analyses are contained in Appendix C of this report.

#### 4.1 VALIDITY OF THE ASSUMPTIONS MADE IN THE ROSENBLATT METHOD

Figure (2) shows a macro-flow diagram of the method developed by M. Rosenblatt for analyzing minor or low-energy collisions. The method incorporates several key assumptions and simplifications whose validity has been assessed. Comments on each of these assumptions are presented below.

Assumption: The bow of the striking ship is rigid and infinitely stiff.

Comments: At first glance this seems to be a conservative assumption since the energy going into the deformation of the blow is neglected and, consequently, more energy goes into the side shell and greater penetration is produced. However, this is not necessarily true. The deformation of the bow and variations in local contact surfaces may produce much higher stresses locally (by a factor of two or more) than the clean imprint assumed. This is particularly true if the bow of the striking ship has continuous longitudinal girders and rupture or puncture of the struck vessel's shell may occur. The larger the energy involved the weaker the infinitely stiff bow assumption is. A frequent

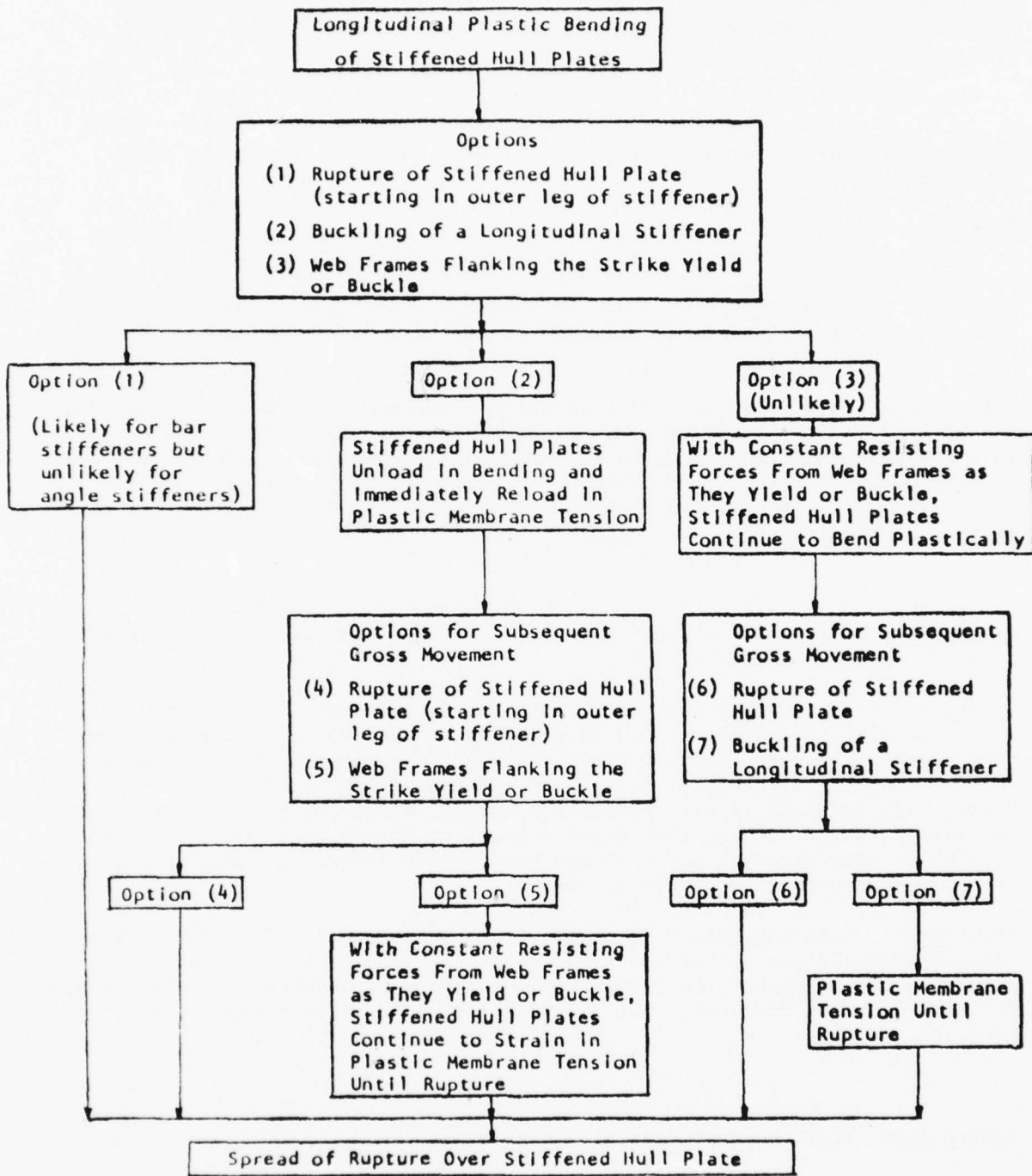

Figure 2 Macro Flow Diagram for Side-Collision Plastic-Energy Analysis for a Single Shell Ship

case is that the inner bottom of the struck ship cuts away the bow of the striking ship.

Assessment: The assumption is good for only very low-energy collisions. Based on casualty reviews most collisions involve damage to the bow. If tearing is not involved the assumption will be conservative.

Assumption: Cutting or puncturing of the side shell of the struck ship does not occur.

Comments: Cutting or puncturing of the side shell has an important effect on energy-absorption capability of the struck ship. If the side shell is punctured a tear may spread destroying the capacity of the region to absorb energy by membrane tension. Thus for larger deformations the energy absorption capability of the struck ship may be seriously overpredicted while for small deformations this is not a serious defect.

Assessment: This is an extremely vulnerable and non-conservative assumption and perhaps the chief limitation to this procedure. The deck of the striking ship may hole the struck ship releasing membrane-tension resistance and permitting deeper incursion. The deck of the struck ship may slice into the bow of the striking ship reducing the energy absorption in the deck and permitting deeper incursion.

Assumption: The bottom of the ship, bilge strake, and transverse bulkheads do not buckle, yield, or rupture.

Comments: This assumption is acceptable for very modest "fender benders" but it is weak for strikes close to a bulkhead. The net effect is conservative since this means that the energy absorption must be contained between two consecutive bulkheads. If the bulkhead yields and the damage propagates beyond this boundary it will reduce the energy absorption in the strike region and less penetration will take place. However, in the case of strikes near a bulkhead high-stress concentrations may produce failure at smaller penetrations than predicted by the method.

Assessment: This assumption is often violated in actual collisions. In the case of a strike near a bulkhead, by not reflecting the energy absorbed in deforming the bulkhead, the method will underpredict indentation before rupture if tearing is not involved. But, in the case of such "hard spots", tearing is often involved.

Assumption: Rigid body motions not considered.

Comments: Rigid body motions absorb at the most 5%-10% of the collision energy.

Assessment: Assumption is satisfactory and conservative.

Assumption: Collision angle remains constant and neither ship rotates during collision.

Comments: If the impact occurs in a region far removed from the center of gravity of the struck ship (i.e. at the bow or quarter-length) significant energy may be absorbed in rigid body rotations.

Assessment: The assumption is conservative.

Assumption: Collision is an inelastic (plastic) process.

Comments: This is not a bad assumption. The curve of energy absorption versus time is undoubtedly very erratic during the short time interval of collision. By assuming completely plastic collision the result is a smooth curve. In the case of very low energy "fender benders" (i.e. a tug bumping a ship during docking and undocking, or a ship bumping a pier) the elastic energy becomes a more significant fraction of the total.

Assessment: The overall effect of the assumption is that it underpredicts the energy absorption so that greater penetration is achieved for a given level of energy. The assumption is conservative and satisfactory.

Assumption: A static process is assumed and dynamic effects are neglected.

Comments: Some strain-rate effects may be present during the first instants of contact but they are minor. The time interval in which this effect is significant is on the order of 1/10 to 1/100 to 1/1000 sec. However, the duration of the collision impact is on the order of 1 to 4 seconds so that this assumption is good. Dynamic effects may offer some increase to the buckling strength of panels in edge compression.

Assessment: The assumption is satisfactory and conservative.

Assumption: Longitudinally stiffened side plates and deck plates act as independent units, that is, there are no in-plane forces between them.

Assessment: The assumption is probably satisfactory for a plumb-bow case while marginal for a raked-bow case.

Assumption: If the top of the striking bow is below the deck of the struck ship the deck does not buckle and the distortion of the shell plating varies from zero at the deck to a maximum at the bow of the striking ship.

Comments: For a raked bow this would be a case most sensitive to tearing or punch shearing.

Assessment: There is probably no feasible alternative to this assumption, but it is vulnerable.

Assumption: Plastic bending and membrane tension effects are considered separately.

Assessment: This is a satisfactory assumption which is supported by the results of the U. S. Steel experiments.

Assumption: If the stiffener flange (longitudinal framing) ruptures, the rupture is assumed to continue through the stiffener and plate.

Assessment: This is a satisfactory assumption which is supported by the results of the U. S. Steel experiments.

Assumption: If a stiffener trips it will unload in bending but reload immediately in membrane tension.

Assessment: This is a satisfactory assumption which is supported by the results of the U. S. Steel experiments.

An additional and independent critique and assessment of the assumptions made in the Rosenblatt method was conducted by Professor Norman Jones. This material has been included in this report as Appendix D.

#### 4.2 APPLICABILITY OF THE LOW-ENERGY COLLISION DAMAGE THEORIES AND DESIGN METHODOLOGIES

The Rosenblatt method, despite its shortcomings, is available now. It is suitable in its present form for the analysis of very minor collisions, say those for which the ratio of the indentation to the spacing between webs is on the order of 1:10. A good application, for example, might be a study of damage occurring to ship's side plating in collisions with piers, camels, etc. during berthing operations. To press the method to indentation/span ratios of 1:3 or 1:4 would be pushing the method to a very uncertain limit. One possible way of

using the method in design would be to discount the energy absorption capability of the structure predicted by the method by some factor. At present there is no theoretical or experimental basis for the assignment of such a factor. In the future it might be possible to assign such a factor on the basis of parametric finite-element analyses, large-scale model test results, or full-scale collision test results.

It can be concluded, therefore, that the Rosenblatt method is good for small penetrations not close to the bulkheads (as a guess, perhaps  $L/10$  penetration where  $L$  is the damaged span), say, an 18-inch penetration typically. This figure is a guess and it will take much more experimental evidence than presently available to establish true limit of validity. As the method is pressed to larger penetrations the sensitivity to deviations from the assumed conditions becomes greater. For a collision in which a large penetration without rupture is predicted the prototype might be able to absorb this much energy or perhaps slightly more if the collision closely simulated the assumed scenario, but departures from this scenario could result in significantly less energy-absorption capability--perhaps 50% as a guess--before rupture.

The finite-element method, on the other hand, is a more powerful tool than the Rosenblatt method. It does, however, require that the input be properly formulated. Among the most difficult inputs are the impact load magnitude, distribution and time-history. Characteristically there is an optimum mesh size which in a collision case would require considerable operator experience. One must match the load and deformation of the side shell to the load and deformation of the bow to get the correct contact area and load distribution. The procedure must then be repeated for a series of penetrations.

The finite-element approach could handle a much larger variation in conditions than the Rosenblatt method. This, however, would come at an extremely high cost and high technical risk of delivering a finished product for a given number of dollars. One could easily end up in a bottomless pit situation by refining, debugging and rechecking the model with the possibility of never achieving a general tool for use in the field. To be useful, the method would have to be used by one or two experienced operators to investigate a series of collisions parametrically. However, the end product would still have to be something like the output of the Rosenblatt method or Minorsky's classical analysis (11).

#### 4.3 SENSITIVITY AND RANKING OF SHIP-COLLISION ENERGY-ABSORPTION MECHANISMS

The various energy-absorption mechanisms which play a role in ship collisions have been described and analyzed at length in several reports (1, 2, 3, 9, 10, 11). Several of these mechanisms and their relative importance have been discussed in Section 4.2 with reference to the validity of the assumptions made in the Rosenblatt method for analyzing minor collisions.

Of all the studies reviewed the work reported in the report "Tanker Structural Analysis for Minor Collisions," (ref. 2) is worth summarizing. The ship collision is assumed to consist of four simultaneous phenomena as shown in Figure (3). These are:

- (1) Local elastic deformation of the struck ship
- (2) Rigid-body motion of the struck ship
- (3) Plastic deformation of the struck ship
- (4) Overall elastic deformation of the struck ship

Reference (2) goes on and makes the following statement regarding these phenomena:

"Although these phenomena occur concurrently, it is of interest to note their cause and relation to the overall collision. The local elastic deformation of the struck ship (1) occurs immediately on contact of the struck and striking ships. This will consist of elastic distortions in the struck ship structure in the vicinity of the bow of the striking ship. Also immediately upon contact and throughout the rest of the collision, the striking ship applies a force (the striking force) to the struck ship. Besides causing local structural failure, this force can induce rigid-body motion (2.), vibration (4.), and an inelastic bending of the entire hull girder (4.) of the struck ship. After the local elastic deformation of the struck ship ends, local plastic deformation (3.) will start and end with rupture of a cargo tank."

Before proceeding with the ranking of energy-absorption mechanisms a few comments need to be made based on practical observations derived from this and other studies regarding the factors which affect energy absorption. Important factors to consider are:

##### (a) Scaling

There are severe limitations when scaling up the experimental results on models in order to predict the behavior of full-sized ships. In general the model structure must be made of a different material, such as a plastic material, in order to model dynamic structural effects. If steel is used for the model then a very large model is required to minimize the error introduced by ignoring this requirement.

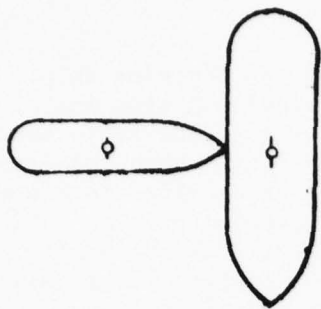

LOCAL ELASTIC ENERGY ABSORPTION  
DUE TO LOCAL ELASTIC STRUCTURAL  
DEFORMATION OF THE STRUCK SHIP.

2.

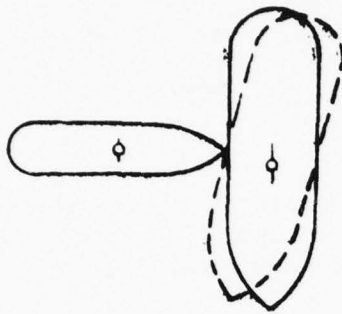

SHIP DYNAMIC ENERGY ABSORPTION  
DUE TO TRANSLATION AND/OR ROTATION  
OF THE STRUCK SHIP.

3.

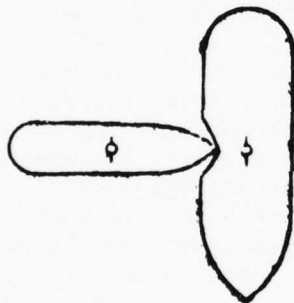

LOCAL PLASTIC ENERGY ABSORPTION  
DUE TO PLASTIC STRUCTURAL  
DEFORMATION OF THE STRUCK SHIP.

4.

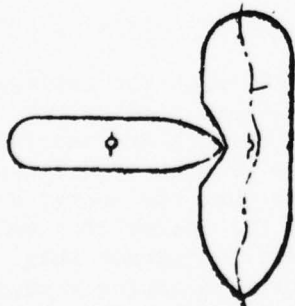

OVERALL ELASTIC ENERGY ABSORPTION  
DUE TO OVERALL ELASTIC STRUCTURAL  
DEFORMATION OF THE STRUCK SHIP.

FIGURE 3  
COLLISION PHENOMENA INVOLVING  
ENERGY ABSORPTION (ref. 2)

(b) Bow structure

The role of the bow structure of the striking ship. This encompasses the effects of included stem angle, rake and framing of the bow as well as the ratio between the strength of the bow of the striking ship and strength of the side of the struck ship. For example, in the work of McDermott, et al (1) it is suggested that an infinitely stiff bow will lead to a conservative estimate of a ship's ability to withstand shell rupture. This may not be so since in a small collision a weak bow may do more damage than a stronger one. This type of failure is discussed by Akita and Kitamura (14) and it occurs when the plate stem of a weak bow collapses against the side shell, but the kinetic energy remaining in the striking ship drives its decks through the side shell.

(c) Angle of collision impact

The relative severity of right-angle impacts in the central region of the ship versus either oblique or eccentric collisions must be considered.

(d) Added mass

This has not received much attention. The work of Minorsky (11) is reflected in figure (4) which shows the effect of added virtual mass of the water on the energy absorbed in a collision. Based on previous studies of transverse vibrations of hulls, Minorsky suggests a value of added mass equal to 0.4 times the mass of the struck ship. Later experimental studies by Akita (3) show this to be true only when the impact duration is short. Thus, a good handle on the shape and duration of the collision force impulse is needed as well as additional tests to measure the added mass of the entrained water.

(e) Energy absorbed by the struck and the striking ships

This is a difficult problem because of the enormous complexity of actual ship collisions when such a large number of different structural members are involved. Minorsky (11) circumvented this problem by defining a resistance factor which assumes that the energy absorbed is essentially proportional to the volume of steel damaged in the striking ship and the struck ship. Minorsky then plotted the resistance factor versus kinetic energy loss during a collision. This is demonstrated in Figure (5) which shows data from a number of actual ship collisions collapsing onto a straight

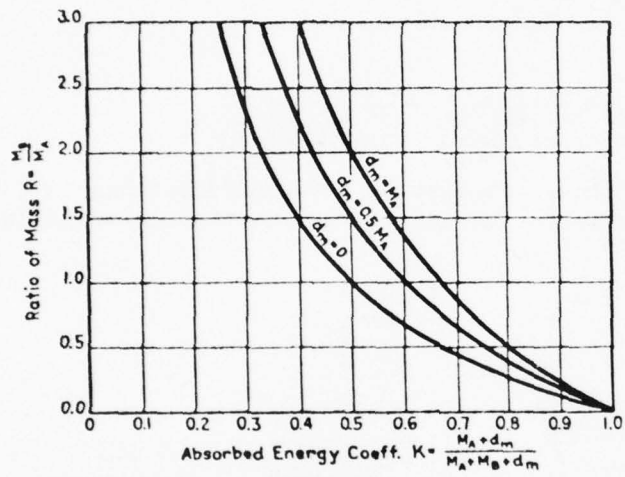

$d_m$  = virtual mass  
of water

$M_A$  = struck ship  
mass

$M_B$  = striking  
ship mass

Fig. 4 Effect of added virtual mass of water on energy absorbed in collision (ref. 11)

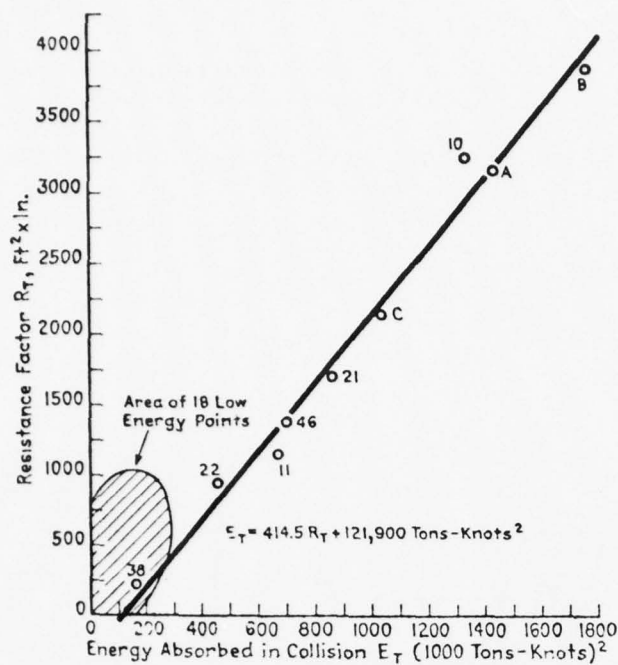

Fig. 5a Empirical correlation between resistance to penetration and energy absorbed in collision (ref. 11).

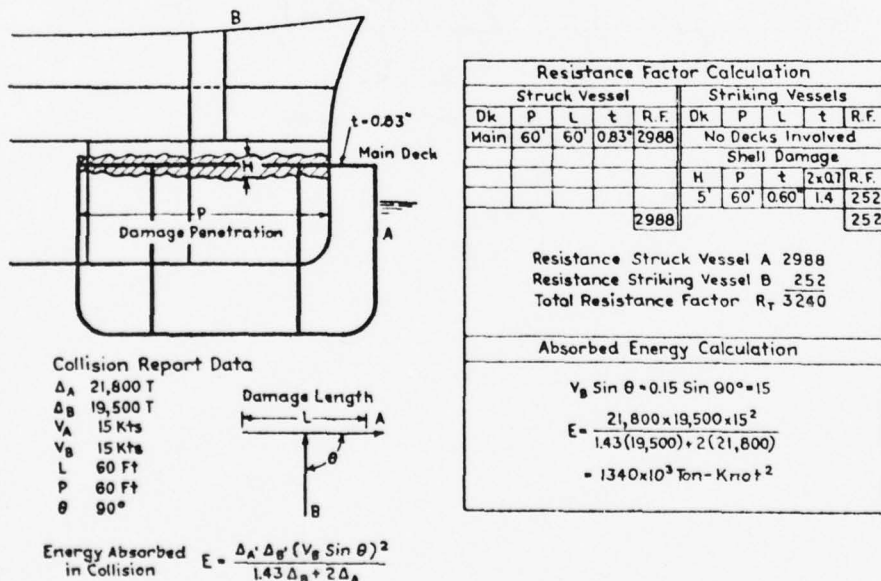

Fig. 5b Typical calculation for resistance factor and absorbed energy. (ref. 11).

line. Also shown is the calculation of the resistance factor and absorbed energy. However, Minorsky's method in its present form is applicable only to the high-energy type of collision where rupture occurs and membrane tension is unimportant. Our present concern is with low-energy collisions where membrane tension appears to play a significant role.

(f) Static vs dynamic loading

The work conducted by McDermott, et al (1) outlines a rational approach to the analysis of tanker low-energy collisions and concludes that most of the energy absorbed during a collision is that of membrane tension in the stiffened hull, deck and in-plane shearing of web frames. However, the theoretical procedure is developed using statical considerations alone. This viewpoint is quite adequate when the duration of impact is much longer than the corresponding natural period of elastic vibration of the hull plating. However, if the natural period of the plating is less than the duration of impact, then considerable errors can arise as demonstrated in Reference (15).

Based on the review of the analytical and experimental works which have been described elsewhere in this report, along with the observations drawn from full-scale ship collision data, the energy absorption mechanisms have been ranked and grouped into three different categories: Primary or significant, secondary or not very important, and tertiary or negligible. By considering the factors (a) through (f) above the following ranking of mechanisms was derived.

Primary

1. Membrane tension in plating deck and stiffeners
2. Plastic bending in plating deck and stiffeners
3. Plastic energy in shearing deformation of web frames
4. Rigid body motion (translation and rotation)

Secondary

5. Elastic bending
6. Elastic vibration

Tertiary

7. Thermal

## 5.0 CONCLUSIONS AND RECOMMENDATIONS

### 5.1 GENERAL

Much has been learned in this study and recommendations can now be made based on the conclusions derived from the evaluation of the existing low-(and high) energy collision theories and methodologies. It is clear that a fully satisfactory solution of the problem of predicting the damage which would occur in ship collisions in general and low-energy collisions in particular will be extremely expensive. An estimate on the order of five to ten million dollars would not be unreasonable but such a figure is far beyond what would normally be available. However, the picture is not really quite that gloomy in that compromises can be made between the ideal approach, and the more approximate methods with the final objective being the development of a cost-effective way of handling the problem of collision-damage prediction for use in hull design.

At the present time there are three paths to follow in arriving at the acceptable tool. These are:

- (1) The Rosenblatt method
- (2) The extension of Minorsky's high-energy method into the low-energy range
- (3) The finite-element method

The Rosenblatt method is available now and would be the least expensive approach to follow. It does however have some severe limitations, some of which could be eliminated through further development of the method. The finite-element method, on the other hand, approaches the ideal solution but it does so at a very high price, in many cases too high for use in ship design practice. The extension of Minorsky's method to the low-energy range could well be the compromise that is needed in that it circumvents some of the limitations of the Rosenblatt method and it would do so at a relatively low cost by comparison with the finite-element method. Essentially the added cost here would be the funding required to complete and validate the work which has been started in this project (see Appendix C).

### 5.2 CONCLUSIONS

The bulk of this effort has been devoted to evaluating the Rosenblatt and finite-element methods for analyzing low-energy collisions and to establish an experimental data base. Thus it is necessary to summarize the most important observations concerning these objectives in order to provide the basis for future work.

### 5.2.1 Data Base

The search for the "ideal" collision to be used in validating the available prediction methods proved to be fruitless. Of more than 500 collision cases, only 7 were identified as possible candidates. However, all were deficient in one respect or another.

The lesson learned here was that to generate good full-scale collision data a full-scale collision experiment will have to be conducted. The possible exception would be an on-site inspection of a "clean" collision but this requires a large amount of good luck. The search of casualty records should definitely not be pursued. Furthermore it must be realized that there is a vast difference between the real ship collision world and the world of idealized analytical models.

### 5.2.2 The Rosenblatt Method

The Rosenblatt method is perhaps the best available tool in existence to make quick and inexpensive design estimates. The method, however, does have some serious limitations which should be kept in mind when used. Of these, a very serious one is the omission of the prediction of tearing inception during collision. In fact, none of the methods evaluated in this study treat the problem. One feature that stood out in searching through the ship casualty records is that tearing is so often involved. The deck or inner bottom of the struck ship may tear the bow of the striking ship, or decks of the striking ship may tear into the side shell of the struck ship. Once tearing is initiated it is something like puncturing a balloon. Resistance to penetration due to membrane tension is lost and penetration can proceed much further than predicted using the idealized model. A threshold at which tearing would occur in ship structures in collision needs to be developed. Appendix D gives Professor Jones' thoughts on this problem.

Apart from the introduction of a tearing threshold criteria there is not an obvious potential for major improvement of the Rosenblatt method. To utilize the method for design there would have to be an arbitrary discount of the predicted results. Say, for example, 50% on energy-absorption capability or, perhaps, double the predicted incursion depth. A basis for establishing a viable discount scheme needs to be defined.

In summary, then, the following final statements can be made regarding the Rosenblatt method:

1. The most sensitive assumption is the no tearing assumption.
2. The energy-absorption capability predicted by this method should be regarded as an upper limit, that is, in most cases the structure will not absorb as much energy as predicted without rupturing.
3. Within its limitations the theory is sound and represents an ingenious splicing of standard plasticity theory and empirical data.

### 5.2.3 The Finite-Element Method

The general concept of using finite-element analyses to predict structural response of a ship structure is accepted as the best way to approach such a complex problem. There are several difficulties however:

1. Due to the complexity involved the cost is high. Therefore, this is not an everyday design tool. Its use is limited to checking final designs or to more frequent use during the design of critical structures (such as the barrier of a nuclear ship which can strongly influence the rest of the design (weight, arrangements) or may even render an overall design acceptable or not).
2. The expected loading is required as input to the finite-element analysis. Load prediction models are complex in their own rights and much additional R&D is required in this area before reliable, accurate and inexpensive models become available.
3. Choice of the boundary conditions (and the decision of how much of the ship one should model) is not an easy task. Judgement guided by experience is required (and not readily available).
4. Considerable experience is required to incorporate plasticity and strain hardening features, select the optimum mesh size, and apply the loads in suitable increments. If the bow of the struck ship deforms, the time-dependent load will vary in a complicated way.

Current work in the use of finite-element models for ship-collision analysis is being conducted by Dr. Pin Yu Chang of Hydronautics, Inc. The status of this project has been summarized in Appendix B. A few conclusions have been drawn from discussions with Dr. Chang on the progress of his work. These are:

1. The finite-element method was used in efforts to verify one of the German GKSS experiments. The loads were not measured in the tests but were

hindcast using a method developed by Professor Reckling of the University of Berlin. The results agreed with the experiment within 15%.

2. The present program used by Dr. Chang is not a rigorous upper-lower bound approach. In future efforts he intends to modify the program to incorporate this and also to provide internal (rather than manual) incrementing.
3. Two programs are necessary--one for the side shell, one for the bow--and the results have to be matched.
4. The method is potentially a very powerful tool. It might overpredict or it might underpredict but it would tend to be consistent. The cost of using it, however, is very high. One good run requiring three or four trials could cost as much as \$15K. One of the collision cases analyzed by the Rosenblatt method could be simulated for roughly \$20K.
5. The estimated development cost of the tool is on the order of half-million dollars ( $\pm 20\%$ )

### 5.3 RECOMMENDATIONS

The following recommendations are made for the use of existing methods of analysis and further development work. In each case recommended levels of funding are stated.

1. Use the Rosenblatt method as it is subject to its limitations.

Level of funding: None

2. Test the Rosenblatt method against an actual ship-collision case selected based on a prompt on-site inspection of an actual collision. This involves a sub-project to make shipyard inspections of collision damaged ships. There will be legal constraints on the conduct of such inspections and the release of the data developed and there is a strong possibility that such a project could be carried for several years without fruitful results. Still, the prospects of obtaining useable full-scale information at a relatively modest cost make this effort worth funding.

On the basis of the analysis of an actual collision case modify the Rosenblatt method as needed; possibly by incorporating the refinements suggested in this study. Discount the energy absorption capability by some estimated factor based on the comparison with the actual ship-collision data.

Level of funding: Inspections, \$20K; analysis \$40K

3. Extend Minorsky's method as suggested in Appendix C of this report. Compare the results against actual ship-collision data as in 2. above.

Level of funding: \$50K

4. Undertake a finite-element program and use it to establish improved safety factors for the Rosenblatt method.

Level of funding: \$500K

5. Implement a comprehensive finite-element-method development program validated by large-scale model tests and/or full-scale tests at sea followed by parametric finite-element studies to establish design rules.

Level of funding: \$5 to 10 million

Based on these estimated levels of funding it would seem reasonable that the Ship Structure Committee could pursue recommendations 2. and 3. while 4. and 5. could be the subject of an inter-agency cooperative program at either national or international levels.

## REFERENCES

1. McDermott, J. F., et al., "Tanker Structural Analysis for Minor Collisions," SNAME Transactions, Volume 82, 1974.
2. "Tanker Structural Analysis for Minor Collisions," USCG Report No. CG-D-72-76, December 1975.
3. Akita, Y., et al., "Studies on Collision-Protective Structures in Nuclear Powered Ships," Nuclear Engineering and Design 19 (1972), pp. 365-401, North-Holland Publishing Company.
4. Belli, V., "La Collisione fra Navi e la Protezione delle Navi a Propulsione Nucleare," Istituto di Costruzioni Navali del' Universita di Napoli, Napoli, June 1971.
5. Woisin, G., "The Collision Tests of GKSS," STG, 1976.
6. Woisin, G., "Development of Collision Protection Structure for Nuclear Powered Ships," HANSA, 1974.
7. Woisin, G., "Kollisionversuche Im Schiffbau," VDI Nachrichten, No. 9, 1974.
8. Jones, N., "Plastic Behavior of Ship Structures," SNAME Transactions, Vol. 84, pp. 115-145, 1976.
9. Pakstys, M. P., "Ship Collision Dynamics and the Prediction of the Shock Environment for Colliding Ships," Ph.D. Thesis, Department of Ocean Engineering, University of Rhode Island, 1977.
10. "Criteria for Guidance in the Design of Nuclear Powered Merchant Ships," Gibbs & Cox, Inc., prepared for the Maritime Administration, January 1960, revised May 1961.
11. Minorsky, V. U., "An Analysis of Ship Collisions with Reference to Protection of Nuclear Power Plants," Journal of Ship Research, October 1959.
12. Bovet, D. M., "Preliminary Analysis of Tanker Collisions and Groundings," U.S.C.G. Marine Safety Technology Division Project 713112, January 1973.
13. "Ship Casualty Analysis," George G. Sharp, Inc. Report No. 5516, prepared for Babcock & Wilcox Co. and U. S. Maritime Administration, November 1975.
14. Akita, Y. and Kitamura, K., "A Study of Collision by an Elastic Stem to Side Structure of Ships," Trans. Japan Nav. Arch., 302-316, 1972.

## APPENDIX A

### A SUMMARY OF GKSS COLLISION-PROTECTION WORK

#### A.1 GENERAL

##### A.1.1 INTRODUCTION

The introduction of nuclear power in the merchant marine is closely associated with the development of a satisfactory collision-protection method for the reactor plant. GKSS has been working successfully on the very complex problem of collision protection for more than ten years. In 1965 a test facility was erected on the area of the shipyard Deutsche Werft in Hamburg, where besides many pretests, 12 large-model tests have been carried out to date. Besides pretests and theoretical approaches the main contribution on the collision-protection field has been based on tests of 1:7.5 and 1:12 scale.

##### A.1.2 SUMMARY OF THE COLLISION-PROTECTION WORK

The work on the field of collision protection can be divided into a theoretical part and a model-test part. Both parts have to be developed in parallel to get the full understanding of the complex problem of collision.

For the theoretical part, a series of investigations has been carried out describing the global collision mechanism on the basis of inelastic impact. Analytical relations between mass and energy of the collision parameters, influence of the place of impact and the impulse of rotation of the rammed vessel and estimation of the collision probability have been worked out theoretically. Due to the complexity of the matter no useful prognoses for detailed collision damages or optimization processes for collision protection structures are available to date.

Based on the model tests, members of the Technical University of Berlin are working on the problem of the load developed in single structural elements when acting as part of a complex structure. The aim is to gain an analytical design process for optimum collision-protection structures. This theoretical work is only in the beginning stages and must be supported by model tests. For this reason model tests become very significant; and, in connection with this, the development of special test techniques and special model laws for the extrapolation to actual ships must also be developed.

In the early 60's the University of Hamburg carried out static and dynamic pretests with simple structural elements of different size to estimate the influence of scale effects, of different fastening methods and strain rates.

In cooperation with the model basin HSVA, Hamburg, GKSS has carried out tests on the question of hydrodynamic added mass in the case of

collision. Tests have been performed with different accelerations in different water depths. With a special model technique, pretests--so called plate tests--were carried out. Two plates at an angle of  $90^{\circ}$  cut into one another were tested to study the damage mechanism of decks. Also, different scale effects were investigated. Before starting with the large-model tests comprehensive work was performed to study the model laws. The same stress in the model as in the actual ship was used as a basis. It was determined that extensive work would be necessary to clear up different secondary effects.

The center of GKSS' efforts has been large-model tests. A first series of three tests showed the possibilities of a collision structure of the energy absorbing type. Due to the increasing size and speed of the world fleet, GKSS has developed a collision-protection structure of the resisting type (Figure A.1). Since 1970, nine large-model tests of this type in a scale of 1:7.5 and 1:12 have been carried out successfully with varying collision parameters.

#### A.1.3 POSSIBILITIES FOR FURTHER COLLISION INVESTIGATIONS

Based on the status of the collision-protection field, GKSS proposed the following topics for nuclear-powered vessels:

- Refinement of model laws to extrapolate model results to actual ships
  - Continuing the plate tests with thicker plates (up to 30 mm)
  - Proof of repeatability (by repeating a previously executed test)
  - Admissibility of the repeated impact process (by comparison of a test with one impact and repeated impacts at the same energy capacity)
  - Studying the scale effects (by performing the same tests at different scales, i.e., 1:7.5 and 1:12)
- Extension of previous large-model tests with the collision protection of the resisting type
  - Carrying out a test with the side model of the proposed 80,000 HP nuclear containership (NCS-80) and the forebody of an arctic icebreaker
  - Studying the questions of oblique impact in the area of the reactor plant
- Optimization of collision-protection structures based on the development of analytical design criteria
  - Optimization tests on the basis of the construction principle applied
  - Comparison of different construction principles
  - Parallel development of analytical design processes
  - Investigations on the acceleration behavior in case of strong forebodies

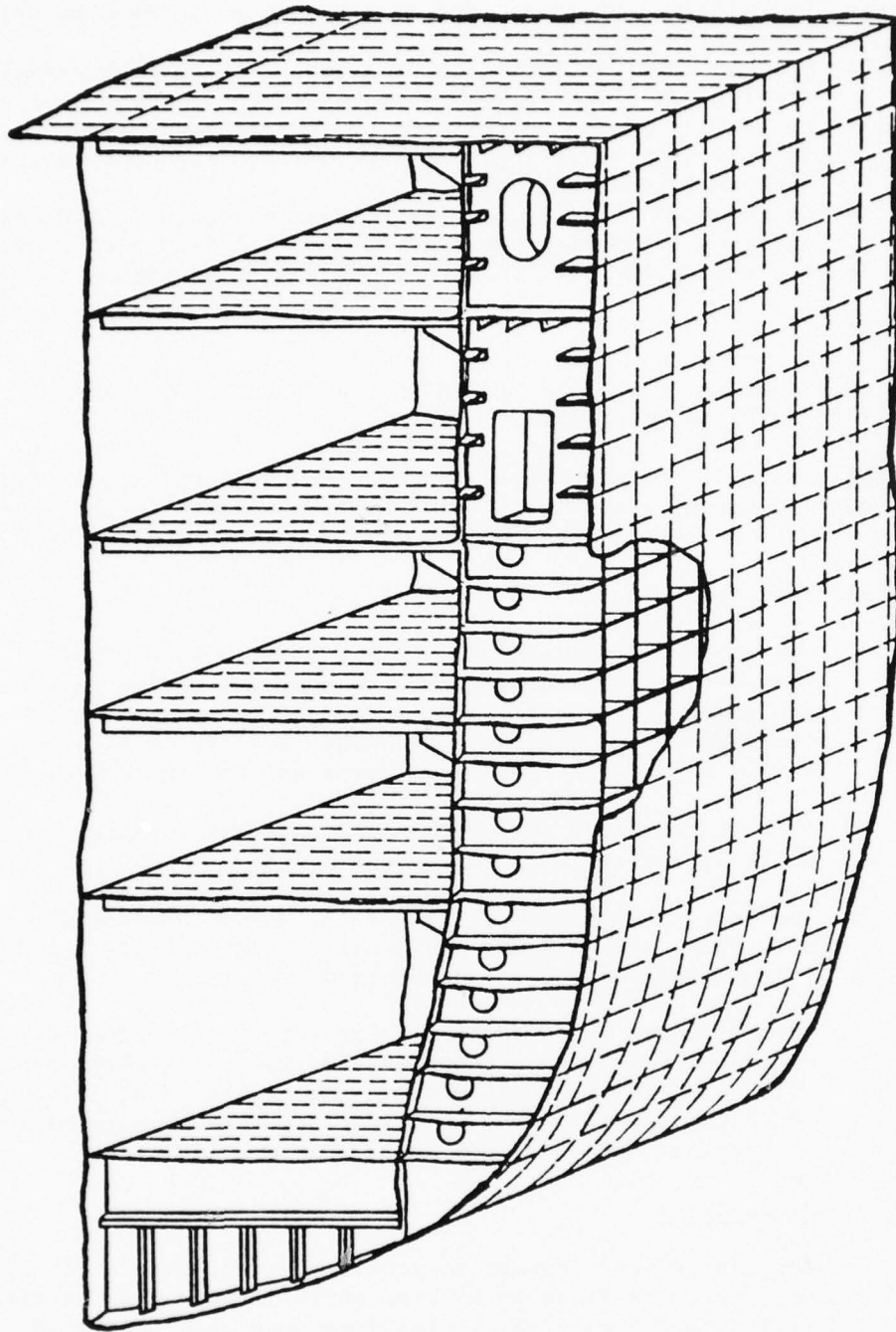

Figure A.1 GKSS Collision Protection Structure of the Resisting Type

- Theoretical investigations
  - Calculations of impact forces produced by forebodies which are used in testing
  - Calculations on the motion behavior of the struck vessel and the reactor plant at heavy impacts in the reactor area
  - Refinement of the calculation process to predict the response of an energy resisting collision barrier (in cooperation with Technical University Berlin)
  - Calculations and, if necessary, special tests in a model basin to study the motion behavior of vessels after a collision
  - Continuing the development of the theory of impact mechanics

## A.2 SPECIFIC ITEMS

### A.2.1 STUDIES PERFORMED BY GKSS TO DETERMINE SCALE EFFECTS AND IMPACT VELOCITIES USED IN THESE TESTS

Studies on simple beams, plates, and plate-frame combinations have been carried out at the University of Hamburg under GKSS sponsorship. A few remarks on these tests follow.

#### A.2.1.1 Beam Tests

The carriage applied a known impact force on a simply supported beam. The size of the beam was varied to simulate scales of 1:1 down to 1:25. Some of the beams were one piece, some welded and some were soldered (see Figure A.2). Other variables were the impact velocity and the ram inertia.

Efforts were made to determine the effects of strain rate, while measuring the scale effect (if any).

The results were very satisfactory in that the scaling laws were correctly followed and no strain-rate effect was noticed. Tripping was expected and observed.

In some cases the welds or the soldered connections were separated. It is not known whether the tests where separation occurred were considered valid or not. The joining technique and its effect on structure flexibility and locked-in stresses have not been analyzed.

#### A.2.1.2 Plate Tests

Two plates were brought together, edge-on, rotated by  $90^{\circ}$ . One plate was fixed on a frame while the other was moving (fixed on the carriage). The frame was used to provide a more realistic support (see Figure A.3).

The impact velocity was approximately 20 knots and remained approximately constant for all tests. The reason this particular speed was chosen was that at 20 knots the facility limits were reached.

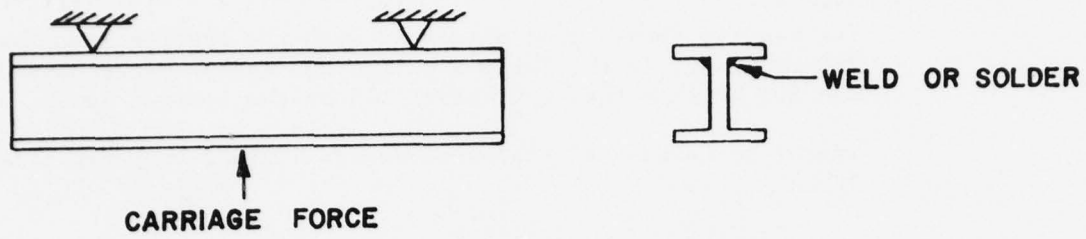

Figure A.2 Impact Force Tests on a Simply Supported Beam

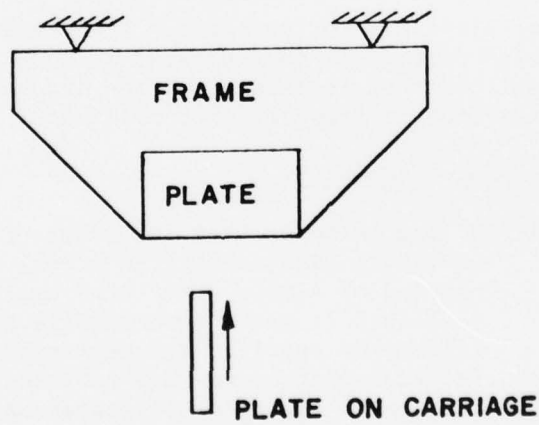

Figure A.3 Impact Force Tests Between Two Plates, Edge-on

Plate thicknesses varied from 2 mm to 10 mm. No welds were modeled. Some soldering and soft soldering was attempted but was later abandoned.

The results showed poor agreement with the scaling laws (see Figure A.4). At the low end (2 mm) the measured response was 50% greater than that predicted by the scaling laws.

Impact force was calculated as energy divided by penetration depth.

The 50% discrepancy at the low end meant that for a constant deformation, 50% higher impact energy was required than that predicted by the scaling laws. These results tend to set a 1:25 limit on testing scale.

Similar results were also observed in the Japanese tests where for slow impact speeds and a small variation of speed, a 20% variation in results was measured. The variation was assumed to be due to strain-rate effects.

During discussions it became apparent that the Germans were not aware of very recent work by the U. S. Navy on the fracture scaling difficulties as plate thickness varies. This work is rather new while the German tests were carried out several years ago. The results of the tests may be better if viewed according to this new U. S. Navy research.

#### A.2.1.3 Plate-Frame Combinations

The geometry and load in these tests were as shown in Figure A.5.

The plate was to represent a longitudinal bulkhead and the "ring plate" was to represent a frame (or web). GKSS admitted that in this case, the load was not in a proper direction to simulate side collision.

#### A.2.1.4 General Methodology

- (i) Woisin believes that the interaction of one piece of structure with another in a real collision made the testing of simple structures useless. The Germans feel that it was not worthwhile to define modes of failure of specific structures and examine the mix of failures that occur in a real collision. They feel that there is no deterministic way to evaluate/predict failure for future collisions by gaining knowledge from a large collection of simple tests. Stochastic processes of evaluation are not considered. In discussions at GKSS, Genalis indicated that such an

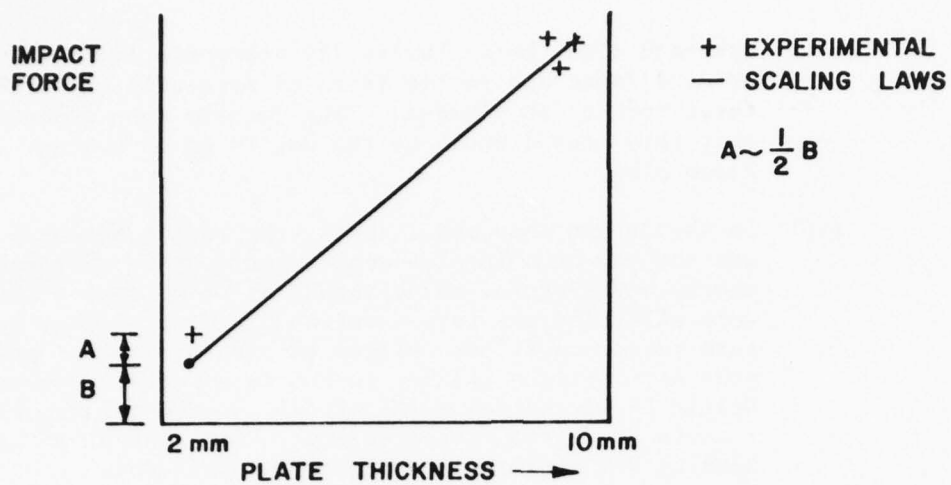

Figure A.4 Comparison of Plate Impact Force Test and Results with Prediction Based on Scaling Laws

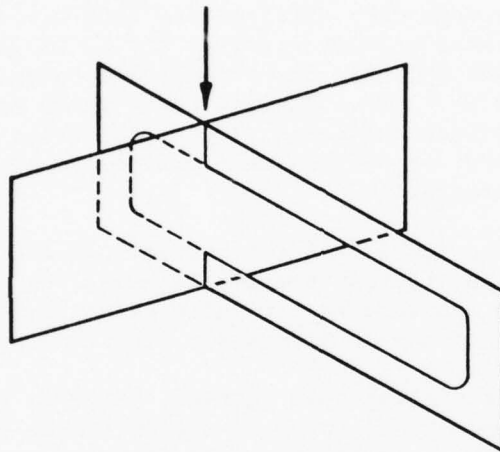

Figure A.5 Impact Force Test Arrangement with Simulated Ship Plate-Frame Structure

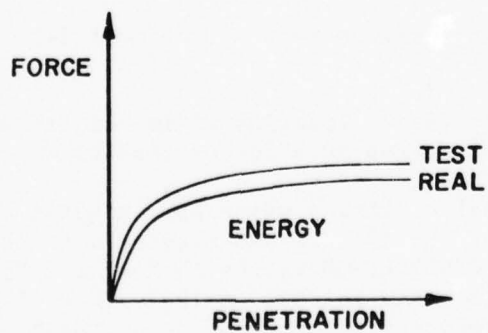

Figure A.6 Relationship of Impact Force and Penetration for a Resisting Type Barrier

approach might hold promise, if appropriately aided by many tests and geosim tests of more complex structures such as ship models. The Germans then conceded that this indeed would be the way to go in a long-range plan.

- (ii) In the German ship-model tests, the effect measured was the bow crushing "to scale" for a given collision energy. Therefore, value and duration of impact forces were affecting the test duration of impact. This in turn raises questions related to strain rate and grain size similarities (higher forces in models). However, Woisin feels that no major errors entered the reported results because of these effects. His reason is that bending and buckling are of more importance.
- (iii) The test facility assumes that the struck ship has zero speed, that the striking ship has a velocity normal to the struck ship's axis and that the collision is "symmetric" which is interpreted to mean "at the CG". It has been very difficult to find a real collision with these characteristics<sup>1</sup> and it is for this reason that the GKSS has not attempted to simulate a real collision. (Some Italian tests which tried to simulate a real collision, i.e., the struck ship had some velocity, non-central and oblique impact, etc., were unsuccessful.)
- (iv) GKSS has found that for barriers of the energy absorbing type Minorsky's analysis holds very well. In fact Woisin has some test results which show excellent correlation with Minorsky's published analysis.
- (v) For a resisting type barrier, GKSS has found that the relationship of force of impact versus penetration is as shown in Figure A.6. The tests are higher due to the general effect of factors such as strain rate, grain size and other such uncertainties.

#### A.2.2 PARAMETERS MEASURED DURING TESTS WITH FLOATING MODELS

The following list includes some of the most important parameters of collision testing:

- a. Added mass versus location of impact (eccentricity).
- b. Added mass versus duration of impact.

<sup>1</sup>With regard to finding a real collision which approximates the condition of "symmetry" (normal impact at the CG), it was suggested to check the records of the accident of the USS BENEVOLENCE vs the SS MARY LUCKENBACK. The accident occurred in San Francisco Bay in 1951 or 1952. One of the ships was a Navy hospital ship and therefore a plethora of data probably exist.

- c. Accelerations during impact.
- d. Bending moments in the model hull.
- e. Added radius of gyration versus hull form.
- f. Added radius of gyration versus location of impact.
- g. Added mass versus depth of water.

Floating model tests were performed at the Hamburg Model Basin (Hamburgische Schiffbau Versuchsanstalt) under GKSS sponsorship and monitoring. Added mass, added radius of gyration and variation with depth were studied. Impact location equivalence was controlled by the arms supporting the model (see Figure A.7).

Known acceleration of the toothed wheel on the fixed track produced known transverse accelerations, since the curvature of the cam was known for each test. Several such curves were tried providing constant linear and sinusoidal accelerations in the transverse direction. Forces were measured in the arms, and therefore, knowing the accelerations and model mass, the added mass was computed. To measure added gyradius, one arm was de-activated. Added mass in surge was also measured. Different impact durations were simulated and the tests were carried out both in the towing tank (deep water) and in a maneuvering basin (variable depth, from shallow to deep).

The repeatability of the tests was so poor that the model basin, at its expense, did the complete series of experiments over again, modifying the setup, based on their experience from the first series. One notable lack of agreement point was the following: Deep water tests in the towing tank did not match the deep water test results in the maneuvering basin (the limiting case of shallow water tests) in either the first or second series of tests.

In general it was observed that for a given duration of impact the bank of results was approximately 40% in width (of the average values). It was also felt that there is no good way to predict the impact duration during a real collision. Both Woisin and previous work by Motora indicate that the added mass and added gyradius are strong functions of impact duration, but weak functions of water depth.

The model tested was a 1/70 scale of the OTTO HAHN. The choice was based on convenience, since the mold of the model existed and had been used for previous tests. The Germans feel that the block coefficient was not an important variable. Length/depth ratios were not investigated (but probably have a significant effect). Furthermore it was determined that the model tested should be as close to the intended ship as possible because of the large experimental uncertainties.

Some of the results of these efforts have been published by Woisin in the 65 Volume of Jahrbuch, Schiffbautechnischen Gesellschaft, 1971 (German SNAME).

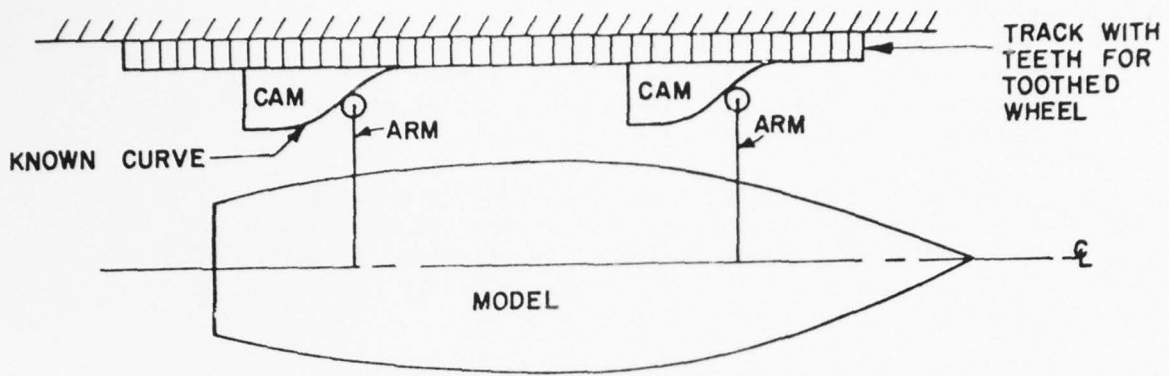
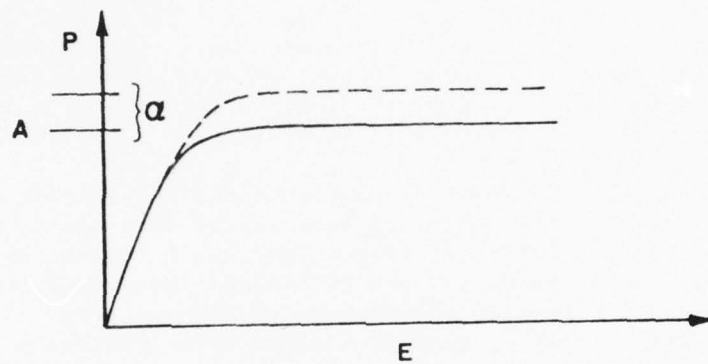

Figure A.7 Model Arrangements for Measurement of Added Mass at Hamburg Model Basin



A HAS 10% SCATTER  
 $Q$  IS 10-15% OF A

Figure A.8 Range of Experimental Variation in Force-Penetration Tests

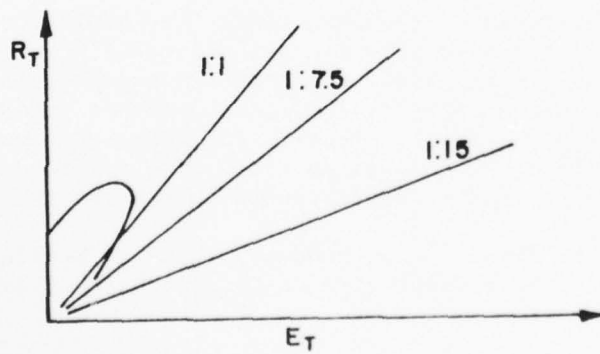

Figure A.9 Woisin's  $R_T$ - $E_T$  Diagram Showing the Effect of Scale Ratio.

### A.2.3 TESTS TO DETERMINE SCALE EFFECTS OF WELDING

The Germans have not indicated any knowledge of tests currently being carried out to determine the inter-relationships of fracture, element thickness, welded strength, locked-in stresses and structure loss of stiffness due to fabrication.

These tests would help interpret collision damage. They are however extremely complex and time-consuming.

### A.2.4 ASSUMPTIONS USED IN DETERMINING THE ALLOWANCES FOR SCALE EFFECTS IN THE RESISTING BARRIER DESIGN

On the force vs. penetration diagram previously discussed, the model results were 10 to 15% higher than the expected real collision. However the real collision has a scatter of approximately 10%. Thus, the range of allowance would be up to 25% to cover all possible excursions (see Figure A.8).

The Germans consider two types of factors of safety:

- (a) Extrapolated from tests (geosims), based on standard design calculations; i.e., if a design calls for a 1" member, and it is designed 25% thicker (1.25") to account for the scatter, etc., then what factor of safety would be required beyond this?
- (b) What allowances should one make to account for future fleet growth?

The answer to the question of ignorance of design analysis and design loads lies in that, unlike the case with the SAVANNAH (where there was no factor of safety per se, but rather, an index of the probability of collision was used), the new barrier design requires no such "probability of collision" factor. The reason for this is that with the resisting barrier one should worry more about the bow of the striking ship rather than the barrier. This was demonstrated in two ways:

- (a) Models of various tests show that it is indeed evident that the bow-collision damage is extensive (the material folded neatly into accordion folds for 2 or 3 model feet) while the side of the struck ship shows bent shell, but intact grillage under it.
- (b) A range of different striking ship bows have been used, including the following:
  - 200,000 ton bulk carrier with bulb
  - 200,000 ton containership with bulb
  - Passenger ship FRANCE, narrow entrance, 19 knots
  - OBO "TARIM" with cylindrical bow

GKSS feels that this range of different bows would be sufficient for all types of ships and for future fleets, because no major changes are expected in bow design, shape or hardness, and in ship size and

speed. GKSS suggests that a very hard bow, such as that of an ice-breaker would be a good addition to the above tests. GKSS points out however, that the key issue is not the energy to be resisted or the total impact force, but rather, the impact force felt by the struck ship, and in particular, the force felt at the hard points of the structure. Based on this the Germans believe that if a barrier can stop a collision in the 5 - 10 knot range, it would probably resist any higher velocity, since as the bow collapses the bearing area increases and therefore the pressure decreases. Stated in a different way, the collision barrier is not designed to withstand a given force; the barrier will resist any bow, or the struck ship will break due to other phenomena. Pressed for specific values, the Germans mention impact forces of 40K to 45K tons for the bulk-carrier test.

#### A.2.5 BARRIER OPTIMIZATION

Turning to optimization, the question becomes one of picking "enough barrier to do the job", {i.e., a 6' barrier won't stop any ship, a 15' barrier will stop everything; therefore, the "solution" is somewhere in between. How does one determine this optimum?} Calculations to this effect have not been carried out. Some efforts (using data from real collisions, Germanischer Lloyds rules and a finite-element analysis computer program called SAP IV) have been given some thought but have not been started. Finite-element computer programs could be very useful since only the total load can be approximated, but the distribution is virtually unknown. The program could be used to perform a parametric study and the procedure could then be refined using results from the model tests until an optimum design were reached. Genalis and Dietrich are the primary proponents of such a design approach, but Woisin does not believe it to be cost effective.

The Germans feel that the fact that the grillage of the barrier remains elastic, provides an added factor of safety. It is not clear however whether this is necessary, in the sense that allowing some plastic deformation for severe loads is accepted practice for U. S. Navy Ships.

GKSS recommends plotting all available knowledge (real collisions, tests and computations) on a diagram similar to Minorsky's to check for possible patterns. Woisin's 1967 paper includes guidance on the question of how this should be done.

Finally, guided by their experience (not calculations as mentioned above) and by plots similar to Minorsky's, the Germans did attempt a crude barrier optimization. The same barrier was built of three different plate thicknesses, as follows:

	I	II	III
t	33 mm	18 - 21 mm	12 mm
scale:	several	$\frac{1}{7.5}$ & $\frac{1}{12}$	$\frac{1}{12}$

Barrier I; showed no failure on collision with ESSO MALAYSIA and a containership bow.

Barrier II; showed large penetrations.

Barrier III; was considered the best choice and four tests were run using a cylindrical bow and a containership with bulbous bow.

Based on the above tests, Prof. Reckling (Technische Universitat Berlin) recommended a thickness of 24 mm. GKSS however retained the 21 mm thickness because they expect the Germanischer Lloyds to request the 24 mm.

GKSS agrees that there is no way to perform an optimization of the barrier structure by performing tests only. A large computer program would be more suitable to the analysis and a follow-up optimization routine should be used.

The question of measure of merit in the optimization is important and GKSS feels that cost and steel weight may yield different optima, especially in view of the current economic trends (manpower vs material cost). Further, the optima could be different in different countries. Reports of the Duetsche Werf have suggested that welding cost is the driving item in a cost optimization, and therefore the thinner the stiffener/plate combination, the less the welding and the cheaper the barrier.

#### A.2.6 EXTRAPOLATION TO FUTURE SHIPS

In view of the German regulatory requirement that the barrier must stop any vessel except naval vessels, the question of how to extrapolate tests to allow for 33 knot containerships and VLCCs becomes important.

GKSS experience is that the German regulatory authorities will require that the barrier "resist everything" unless a satisfactory probabilistic analysis is presented accounting for future ships, routes, frequency of travel, etc. Since such an analysis would involve shaky data, GKSS has been handling the problem from a "resist everything" point of view. They feel that the current design is strong enough to stop everything now and in the future, as shown by their tests with different bows (icebreaker test pending) and based on their belief that no design surprises will occur.

#### A.2.7 STUDIES OF THE MECHANICS OF THE CRUMPLING OF THE STRIKING SHIP'S BOW

Prof. Reckling (TUB) was tasked to compute the behavior of a bulbous bow upon collision. His conclusions were proven wrong at the first tests. However, using the information of these tests an analysis was formulated which matched the experimental results quite well. For bulbous bows the analysis is based on the sphere implosion approach and accounts for different bow hardnesses.

Elements of the analysis are summarized in Reckling's 1976 STG paper and Genalis has prepared detailed analysis procedures for load computations. Minorsky has used these procedures to compute bow crumpling loads and comparisons to sparse measurements are encouraging.

#### A.2.8 MATERIAL PROPERTIES

Only sporadic tests have been carried out to check for temperature effects related to impact resisting properties. This transition temperature concept was investigated with regard to the plate tests because the shipyard (HDW) had reported some "winter damage", i.e., brittle fracture.

Dry ice was used to drop the temperature of the barrier model to  $-20^{\circ}$  C locally. These tests were carried out to differentiate between summer and winter damage. Yard experience was verified in that changing the plate thickness causes the transition temperature to change. (Note, again, the lack of information on fracture vs plate thickness for given temperature.) This change affects modeling since by necessity, plate thicknesses are different.

No experience with grain size, direction of roll, composition of steel, was sought or gained.

#### A.2.9 REPEATABILITY OF TESTS

##### (i) Identical Scale

No two exactly identical tests have been run. However, the results of two almost identical experiments have been compared.

A bow was crushed on a collision barrier in five blows. (This process and its acceptability is discussed later.) The same bow design, with the addition of a cast iron piece at the water line was crushed on a similar barrier, in two higher energy blows.

For the same penetration only a 2 or 3% variation was observed.

##### (ii) Same Tests--Different Scale

Tests of the tanker ESSO MALAYSIA were repeated in two different scales.

The small model (1:12) was complete, in the sense that the collision bulkhead was included. The whole bow was then filled with water to increase the inertia of impact. The water transmitted the impact load (pressure) to other parts of the bow and caused additional damage unrelated to the primary impact.

The larger model was a 1:7.5 version of the same ship. This size however was too large for the available facility. Therefore only the bottom 15 m (full size) were modeled, the higher part of the bow being ignored. Due to its rake, this was considered to be a conservative assumption, since after the collision the top part would collapse and therefore spread the load. Because of size limitations the collision bulkhead was not included in the large model and it was therefore impossible to fill the forepeak with water. (The new GKSS facility, if built, will be sized so as to accommodate a 1:7.5 scale model of the ESSO MALAYSIA, including the collision bulkhead, for a 19-knot collision impact.)

In other tests the Germans used a 1:7.5 bow of the BREMEN to compare results with 1:15 model of the same ship with which the Italians had experimented. (Both tests were done on an energy-absorbing type of barrier.) For the same deformation, 30% difference in energy was observed. It was noted however that during both tests several connections (soldered in the Italian and welded in the German tests) were separated rather than broken.

Woisin has presented these findings on a plot similar to Minorsky's original  $R_T$  vs  $E_T$  diagram to show the variation with scale (see Figure A.9).

Part of the explanation for the differences is as follows. Both deformation and tearing work is being done during a collision. The deformation work scales correctly (second power); the tearing work would scale correctly (third power) if the grain size were also scaled. Since standard materials are used, tearing work is not correctly scaled. Therefore, changing scales also changes the collision energy.

The question of different modes of failure becomes significant here. At one time, the testing sequence set-up at GKSS included doing tests of model bows on rigid walls, model side-structure and rigid bows and combinations of the two. Scale effects were to be checked in each case. A final blending was to provide means of evaluating results and predicting damage for future collisions. However, the program was dropped since it was too expensive and too academic, in the sense that it would take too long. This type of approach has been advocated by Genalis and Minorsky.

The force vs penetration shows a threshold value beyond which the force (and impact energy) does not increase. However, that value is different for different bows as shown in Figure A.10. After detailed discussion Woisin and Genalis agreed that the total load of impact

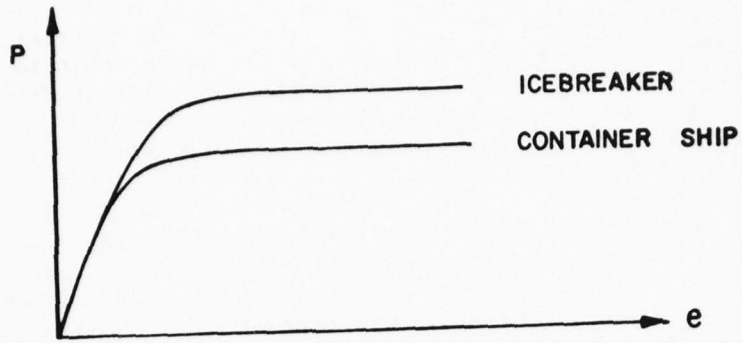

Figure A.10 Effect of Bow Type on Force vs. Penetration

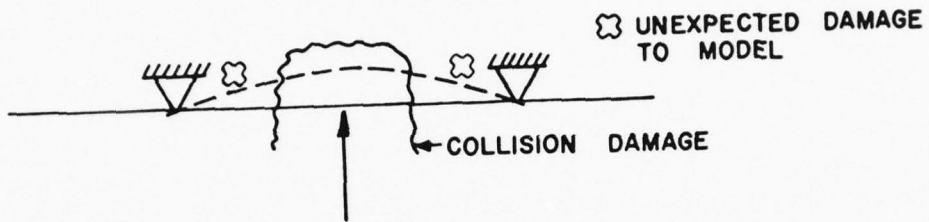

Figure A.11 Model Support System for Italian Collision Tests

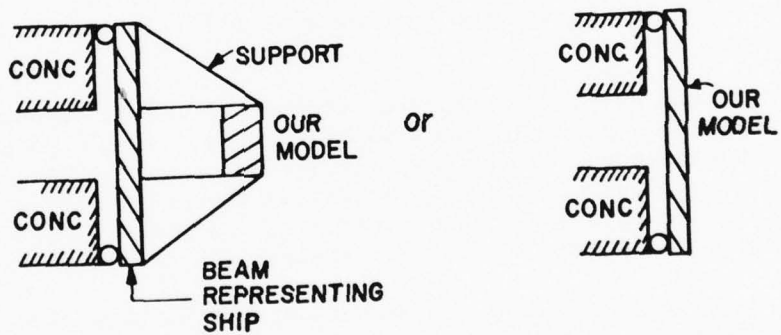

Figure A.12 Top View of Flexible Girder Model Support System used in GKSS Collision Tests

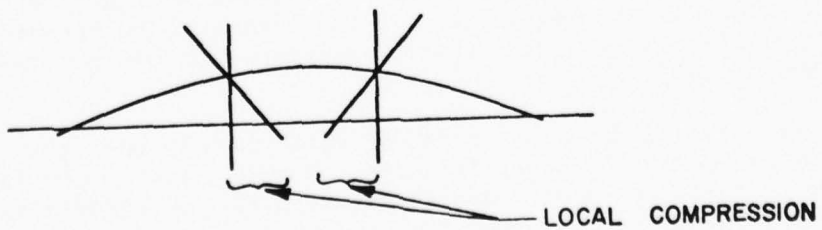

Figure A.13 Bulkhead Rotation Effect

felt by the structure is a function of the barrier grillage response (and hence bow shape also). Scale effects of this type have not been investigated with the ESSO MALAYSIA because of facility limitations.

#### A.2.10 MEMBRANE TENSION AND SPECIAL SUPPORT SYSTEM

GKSS built a flexible girder on which to mount the models because experience from previous Italian tests showed damage away from the area of collision when the model was affixed to a solid foundation (shell and soldered frames separated), as shown in Figure A.11.

To eliminate these problems, GKSS built an elastic girder on which they would mount their models. The girder simulates the response properties of the OTTO HAHN. It has not been changed for other tests due to its prohibitive cost but it is considered to be quite adequate for all other ships tested.

The GKSS test facility sketched in Figure A.12 can provide boundary conditions which can be accurately simulated by the finite-element analysis. An additional benefit arising from the flexible girder is that the rotation of the bulkheads due to the impact load in the area of the load is correctly simulated (local compression), as shown in Figure A.13. Ignoring this phenomenon, as the Japanese did, leads to the conclusion that increasing the thickness of the shell was better for ship protection, which is not correct for high energy collisions. It should be emphasized that the shell compression is only a local phenomenon, because depending on the impact location, an over-riding ship girder tension may exist in the area of impact.

Experimentation with this concept showed that the OTTO HAHN side shell absorbed approximately 5% of the impact energy, which corresponds to the value of the intercept in Minorsky's  $R_T$  vs  $E_T$  diagram.

#### A.2.11 METHOD OF ENERGY APPLICATION

Multiple impacts are presumably an acceptable way to apply the energy. Using two different experiments only a 2 to 3% difference in response was measured when 5 vs 2 impacts were used.

This method provides the opportunity for examination of the damage at different stages. The assumption is that each impact has the opportunity to destroy more bow structure. This was probably not the case with some models that can be viewed at GKSS. Due to the short length of bow model, it was evident that the last one or two impacts (of a total of five) were not realistic, since most of the structure had already collapsed and formed an almost solid body.

In calculating energy levels for the final energy of collision, one must be sure to subtract the elastic energy which is associated with each impact, since in the real case, only once does the structure see elastic conditions. Woisin feels that accounting for the elastic

energy is not difficult. Strain hardening effects are automatically taken into consideration according to Woisin, since the material follows the stress-strain curve after it goes plastic (see Figure A.14).

#### A.2.12 AIRPLANE CRASH

The air crash problem was approached by using a Phantom jet plane and a stationary plant as a model. The impact is on the side of the ship (barrier) and the airplane is simulated as a solid projectile.

Dietrich has written a paper on the finite-element analysis of the phenomenon. Figures in the report show the impact force vs time diagram (imposed by the regulatory bodies), the projectile penetration limits (calculated by formulas used by the German military forces), the assumed barrier geometry (where the outside shell is 38 mm thick and the inside longitudinal bulkhead is 20 mm thick), and the resulting deformations and stresses.

The finite-element analysis carried out on the system described above was done using the computer program SAP IV. This program was selected over others such as NASTRAN and ASKA because of cost, documentation availability and ease of use. Using quite high dynamic load factors (about 2) and an airplane approach velocity of 800 km/hr, the design was found to be satisfactory. Most of the structure remained in the elastic range.

The available form of SAP IV does not contain plastic finite elements and hence the modeling in the area of impact was poor. Further, compatibility requirements among plate-stiffener elements were not satisfied. This would require several computational attempts with varying finite-element mesh sites to establish the rate of convergence to the true solution.

#### A.2.13 ACCELERATIONS

Prof. Reckling has performed some calculations showing accelerations of 1/2 g during impact (expected) and 4 or 5 g after break-up (if it occurs) which is quite surprising. The reason for this is that after break-up the CG shifts far from the location of impact and this creates large lever arms which cause large accelerations (see Figure A.15). The acceleration time history is shown in Figure A.16 and it corresponds to a 40,000 ton impact and a constant ship moment of inertia. The diagram should be read as follows:

"If the ship begins to break up  $t$  seconds after impact, then, of the accelerations observed (somewhere in the ship, at some time after impact) the maximum will not exceed what is shown on the graph."

It may therefore be worthwhile to design a ship so that it breaks up at a given time after collision, so as to minimize acceleration.

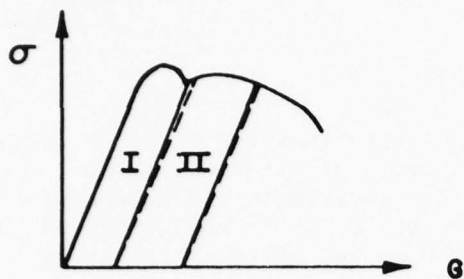

(PARALLEL LINES SHOW THE ELASTIC LOAD AND UNLOAD PROCESS BETWEEN IMPACTS)

Figure A.14 Stress-strain Relationships for Multiple Impacts

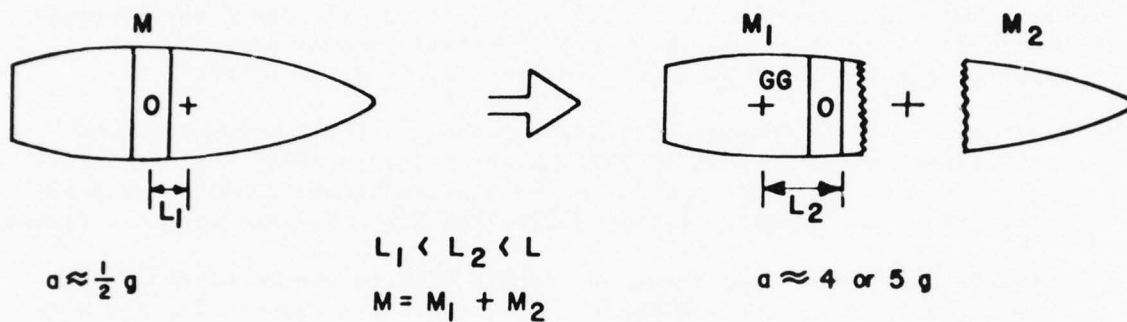

Figure A.15 Center of Gravity Shifts in the Case of a Ship Broken Up in Collision

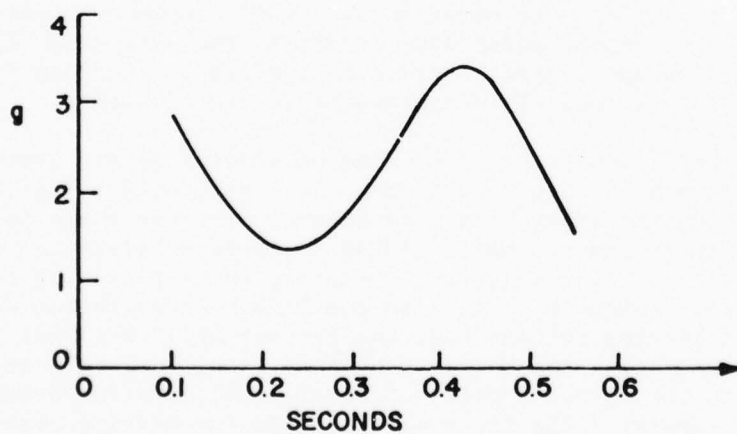

Figure A.16 Acceleration Time-History in the Case of a Ship Broken Up in a Collision

However, investigators feel that such a design would be quite difficult at this stage.

#### A.2.14 RECKLING'S FORCE AND ACCELERATION CALCULATIONS

The experimental force vs time diagram indicates that the force is almost constant for a period of 2 seconds, with oscillations about that constant value. Each peak probably corresponds to the beginning of a bow buckle, since the number of peaks was equal to the number of bow folds. See Figure A.17. The maximum computed value of force was 90,000 MT, but the duration was extremely short.

Measured accelerations were converted to forces (added mass was assumed to be 1/2 of the ship mass) to compare with the computed forces. The agreement was good, with the experiments always having values less than computed (conservative). The computations were based on the upper and lower bound theorems. However, the static-moment distribution required for the lower bound theorem were difficult to obtain.

The method used to compute ultimate stresses is the one described by D. Faulkner in the Journal of Ship Research (March 1975). It is interesting to note that this method is the same as Girard's method of load calculation, but adapted to ship structures (Girard dealt with air frames).

Germanischer Lloyd's has agreed to permit GKSS to use accelerations from LNG ship codes for the NCS80. The values are about 1/2 g for wave motion and 1/2 g for collision. These values are derived by previous experience. It is interesting to note that the ships involved have no collision barriers, but still the society permitted the use of acceleration values related to them.

Reckling's calculations were based on a beam of constant moment-of-inertia along the length, added mass of 50% of the ship mass, also uniformly distributed. Impact force  $F$  is applied to the beam for a duration of  $t$  seconds and five response modes are computed.

As indicated, the computations are based on several severe assumptions and therefore the magnitude 3.65 g shown in Figure A.18 is far from a fixed number. On the other hand, the general response shape is probably correct, in the sense that a higher value of acceleration exists during the first few milliseconds. Comparing the stress wave time to reach the reactor (about 0.01 sec) to the higher acceleration duration (0.02 sec), it becomes evident that the reactor will feel that higher acceleration. Reckling and Woisin published results of this work and presented it to the German Society of Naval Architects in November 1976. Genalis has re-analyzed the force magnitude on the barrier based on bow collapse. A detailed formulation is now available.

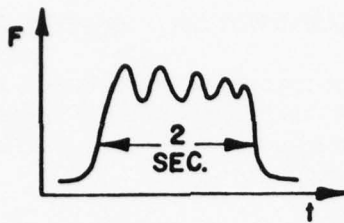

Figure A.17 Experimental Force vs. Time-History in a Collision

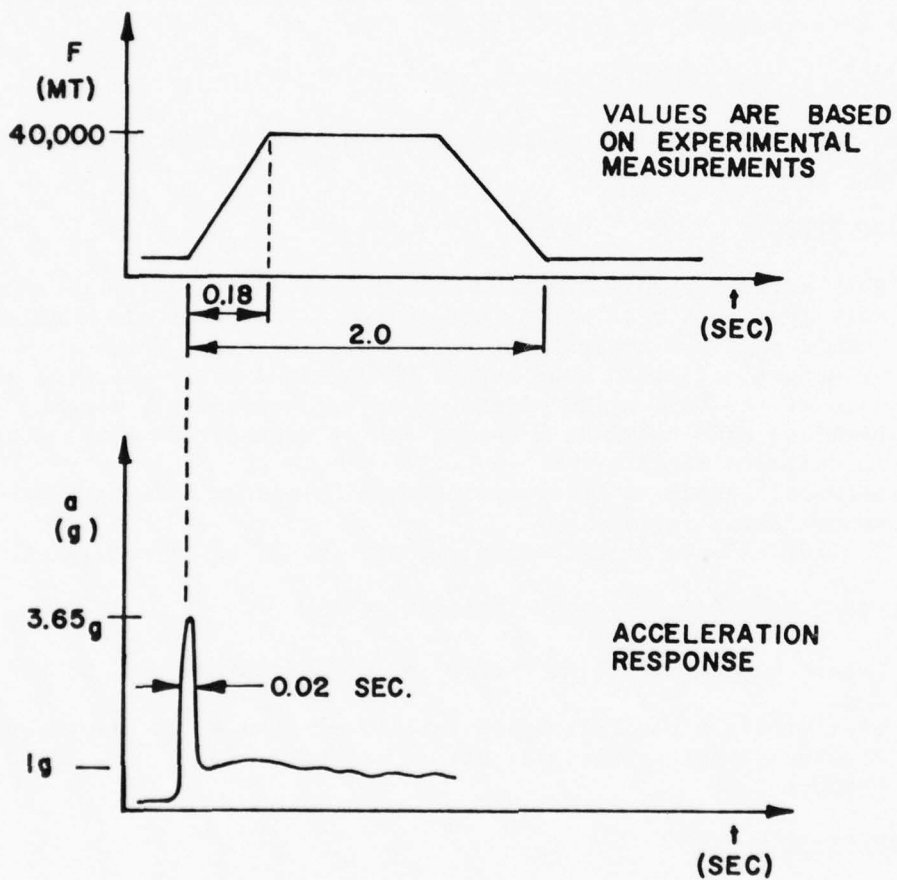

Figure A.18 Reckling's Force and Acceleration Calculations

#### A.2.15 MODEL CONSTRUCTION DOCUMENTATION & QUALITY ASSURANCE

In general the documentation is enough for internal GKSS purposes and has been used for the conducting of experiments at the Deutsche Werf and associated communication purposes with GKSS, Technische Universität Berlin, etc.

To satisfy the Quality Assurance requirements imposed by the Nuclear Regulatory Commission (NRC), construction details, experimental procedure and calibrations to NBS standards are required. Such information is not available with respect to the collision experiments at HDW and would probably be quite difficult to generate for the other associated activities (Hamburg towing tank, TUB, GKSS, etc.). Therefore it is expected that the available documentation will not satisfy NRC's Quality Assurance Standards.

#### A.3 PROPOSED U. S. - GERMANY COLLISION PROGRAM

The following tasks of a common collision program have been proposed by MARAD and GKSS.

##### A.3.1 SCALING EFFECTS

- (a) Both parties should look for a real collision and try to simulate this in a test with at least two different scale models.
- (b) Common plot and analysis of full-scale and model data.
- (c) If actual collision data cannot be obtained or if the simulation of the full-scale collision is not successful, repeat previous GKSS tests at a second and if necessary a third scale to validate results.
- (d) Data collection on structural element behavior must be related to collision failure.
- (e) Scaling effects of fastening methods should be investigated.

##### A.3.2 MODEL TEST EXPANSION USING AN ICEBREAKING BOW

- (a) Obtain bow structure of "Lenin" or USCG icebreaker of a harder one.
- (b) Pre-calculate response using results of Item A.3.3 below and/or the Technische Universität Berlin method.
- (c) Perform test.

##### A.3.3 MATHEMATICAL MODEL

- (a) Develop a mathematical model using a grillage type analysis.
- (b) Develop loading values using methods described by Gerard and/or Reckling.
- (c) Compare math model predictions with a simple test. Iterate till model and test agree.

A.3.4 OBLIQUE IMPACT

- (a) Perform feasibility study and design and cost study for a dry or floating model test facility.
- (b) Analytic study of collision barrier extension in the longitudinal and transverse directions.
- (c) Development of the theory of impact mechanics in unsymmetrical collisions.

A.3.5 INVESTIGATION ON ACCELERATION BEHAVIOR

- (a) Structural behavior of ship after impact.
- (b) Reactor plant acceleration as a result of hull over-stressing.
- (c) Investigate methods of reducing acceleration in way of the reactor plant.

A.3.6 MOTION BEHAVIOR OF VESSELS AFTER COLLISION

A.3.7 ADDED MASS & RADIUS OF GYRATION

Study added mass and radius of gyration at high-velocity impact for different eccentricities, impact duration, water depth, block coefficient.

The following table summarizes the priorities and responsibilities assigned to each task. Priorities were assigned on the basis of importance and urgency to meet MarAd/GKSS schedules (A-highest; B-moderate; C-lowest). Parties in parenthesis are to play a supporting role to the designated lead party.

	<u>ITEM</u>	<u>PRIORITY</u>	<u>RESPONSIBILITY</u>
A.3.1	(a)	A	BOTH
	(b)	A	GKSS
	(c)	C	GKSS
	(d)	C	U. S.
	(e)	B	U. S. (GKSS)
A.3.2	(a)	A	U. S.
	(b)	A	GKSS (US)
	(c)	A	GKSS
A.3.3	(a)	A	U. S.
	(b)	A	U. S. (GKSS)
	(c)	A	U. S. (GKSS)
A.3.4	(a)	B	U. S. (GKSS)
	(b)	A	GKSS
	(c)	C	GKSS (US)
A.3.5	(a)	B	U. S.
	(b)	B	U. S.
	(c)	C	BOTH
A.3.6		C	GKSS
A.3.7		C	U. S.

#### A.4 CURRENT STATUS AT GKSS

During the summer of 1977, Dr. Genalis visited GKSS to discuss the current status and immediate future plans for further collision research. The following are his comments:

1. The discussion centered around the NCS80 project. Letnin stated that the overall project has stopped. As a general concept it has received approval from the reactor safety commission (RSK). Since no near future ship will be utilizing the developed plan there is no immediate program to pursue this design further. However, as part of GKSS's "base program" specific design pieces are being evaluated and approved, on paper, by the pertinent expert groups. For example, specific assumptions used in the design of a specific safety system are being reviewed by the Deutsche Technische Überwachungs Verein (TUB) for specific approval. Similar questions are being investigated with the Institute of Reactor Safety and with Germanischer Lloyds.

GKSS is also spending some time in re-evaluating the economic picture of the NCS80. Shipyard bids to the Inter-Atom and Bremer Vulcan are being refined based on information developed in the first-cut design. Subcontractors are also refining some of their bids. The result of this activity on NCS80 economics is expected to be an evaluation of what economic conditions must be realized before the ship becomes an economic success.

In general it can be said that the NCS80 project manpower and budget have been reduced, but under the GKSS "base program" work is continuing on specific items. The ship collision work is part of this base program (not the specific NCS80 project) and it is therefore continuing as previously planned.

2. The 12th test in the series of model collisions has been finished. The bow of the ESSO MALAYSIA caused no unexpected damage to the barrier designed for the NCS80. More qualitative information (similar to that or previous tests) was gathered. Even though considerable effort had been expended in instrumenting the model, quantitative measurements were unsatisfactory and most sensors failed during the test. However, the qualitative results were good enough to obtain the general approval of the integrated safety enclosure concept for the NCS80.
3. In terms of considering tests with the icebreaker bow, GKSS has decided to wait for the numerical results of the US mathematical model before additional funds are expended, even though their interest is high. One instance which might convince them to deviate from this plan would be a requirement from the Canadians to perform such a test, assuming GKSS involvement in the Canadian icebreaker design.
4. In preparation for the discussion of the small, simple test designed to prove the validity of the Hydronautics numerical model, the discussion was directed toward the current state of the GKSS test facilities.

Of three shipyards in the country around Hamburg, the oldest, Deutsche Werft, was chosen to be closed as the least profitable. This had forced GKSS to consider moving its testing facility (originally located at that shipyard) to the Geestacht grounds. In the process the facility was to be improved and expanded. The yard did indeed close, a dam 6' - 8' high was built (for unknown reasons) and a road was also temporarily constructed to connect some old facilities with the waterfront. The GKSS facility is located behind the dam (away from the waterfront) and near the road. After negotiations GKSS found that the Hamburg Senate might grant them a 99-year lease on the land of the test site and therefore all immediate plans to move the facility were abandoned. In its current state the dam is a nuisance, but the road was a welcome addition. Final decisions have not been made.

Mr. Woisin's general feeling is that carrying out such tests at GKSS would be impossible for several reasons discussed below:

Since the yard has been closed there are no available support services, i.e., electricity, stores, compressed air, water, etc. This situation could be altered but not within a short time.

There are no cranes available to carry equipment and models over the dam, even though this could be a not-too-serious objection if the new road is used.

The tests are carried out by the yard, not GKSS, and the yard does not exist anymore. Even if the group representing the yard were to act as a new form of yard management, they might not be interested in such a small test.

GKSS has no experience in measuring model response. Eleven of their twelve tests involved only half-hearted attempts to measure carriage speed, a few strains and total load at the supports. Since their measurements during these 11 tests were so poor, they decided to really pay attention to the instrumentation of the 12th test. The results of the test were similar to all previous tests: Most instruments failed, what few readings were taken did not make any sense. Woisin mentioned that all their reports of their experiments never show any measurement values. Based on this past performance Woisin felt that GKSS could not guarantee any results from an effort to measure load, strain, acceleration or deflection.

## APPENDIX B

### STATUS OF THE DEVELOPMENT OF THE MATHEMATICAL MODEL OF STRUCTURAL RESPONSE OF ENERGY-RESISTING COLLISION BARRIERS AS OF DECEMBER 1977

In February 1976 Hydronautics Inc. submitted a proposal to MarAd for the development of a mathematical model of the structural response of energy resisting collision barriers. Extensive discussions between MarAd (C. Patterson), G. G. Sharp (V. U. Minorsky, P. Genalis) and GKSS (H. Lettnin, G. Woisin, Dietrich) had previously formed the requirements for such a task. Dr. Genalis was asked to formulate a statement of work blending the previous discussions in the Hydronautics proposal. This was accomplished and Dr. P. Y. Chang proceeded with the modified contract.

The workscope called for six specific tasks, the sixth being left open for further negotiation. These items will now be discussed in turn and comments will be made as to their status.

1. "Currently available, running, documented and generally accepted successful finite element programs will be evaluated to select one to be used in subsequent steps. It is mandatory that the chosen program have the following attributes (in addition to those listed above):
  - a. elastoplastic dynamic-analysis capability
  - b. use of large number of degrees-of-freedom should be possible
  - c. pre- and post-processors of data should be available and documented
  - d. the program should be available to both U.S. and German analysts, either commercially or through a government-to-government agreement."

Status: The following programs were considered: GPAD, EPIC III, H326, OASIS, PLAST2, SAAASIII, DYN5, HONDO, SAMSON, WESTS, EPSOLA, STRAW, BOPACE, CAP, ANSYS, ASKA, MARC, NEPSAP, NONSAP, ADINA. Of these, ANSYS, ASKA, MARC AND NONSAP are found to fit all the requirements. Further discussions with GKSS (Lettnin, Dietrich) resulted in the final choice of ANSYS and MARC for concurrent investigations. Finally, ANSYS was chosen as the most economical. (Reason for the other choices are available)

2. "A reasonable finite element mesh will be prepared, consistent with the power of the chosen element. The model will be of three-dimensional geometry (i.e., including the egg-crate barrier, bulkheads, decks, etc.), but the elements themselves will probably be two-dimensional. Loading and boundary conditions will be consistent with GKSS findings.

The geometry will be checked by graphically echoing the input data via the input pre-processor (plotter)."

Status: This task has been completed. The geometry of the GKSS "egg-crate" barrier was simulated by plate and stiffener elements accounting for twisting, bending and membrane actions of plates, stiffeners and flanges.

3. "Analyses will be carried out for two or three different meshes to determine their adequacy. Consistency of results and use of the next item will be used as a criterion of adequacy."

Status: This task has not been carried out. Therefore the convergence of the finite-element grid as the number of degrees-of-freedom increases has not been investigated and there is no guarantee that an optimum cost vs. accuracy trade off has been made. The result of the chosen mesh seem to predict the experimental results but it is not known if different results would have been predicted with a different (finer) mesh or if the same accuracy could have been achieved with fewer degrees of freedom which would be cheaper.

4. "A simple test will be used to check the accuracy of the mathematical model. The test itself may be carried out by a different organization and is not part of this proposal. The results of the test will be made available to check the results of the finite element analysis."

Status: Due to the schedule of this contract and due to the inability of GKSS to perform such a simple test (temporary loss of their testing facility) this task has not been accomplished.

5. "Upon satisfactory completion of item 4, the full mathematical model will be used to simulate a collision test which has already been carried out by GKSS.

Since loading pressure time-history was not measured during the tests, comparisons will be carried out using the best loading estimates available and will be evaluated by the relationship of the measured and predicted structural responses. It should be recognized that lack of knowledge of the loads will require that engineering judgment be used in case of reasonable disagreement of the responses. Presumably, since item 4 was successfully completed, gross disagreements will not occur."

Status: This task has been completed within the context of the above comments. Boundary conditions simulated the GKSS experiments. Loads used were taken from very rough GKSS measurements. Meanwhile, Genalis prepared a detailed re-analysis and expansion of Reckling's load prediction method. Minorsky then used this method to predict loads in the collision of the OBO TARIM (cylindrical, blunt bow) against the barrier. The results were within 15% of the rough-measured values. An alternate method of load prediction based on Girard's approximations (NACA reports) is under investigation. It is expected that when the load-prediction model is finalized the response model will be re-run with a new set of loads.

6. "The model will be exercised to optimize the barrier. Fixed geometric variables (such as bulkheads, decks, etc.) will not be varied. However, stiffener spacing and modulus will be examined. Engineering values will be used (i.e., only commercially available stiffeners and plating will be considered, stiffener spacing will be limited to sizes which permit fabrication, etc.). Also, other design constraints will not be violated (plating will not be made thinner than required for hydrostatic heads, corrosion allowance, etc.)."

Status: This task has not yet been completed nor is it contemplated.

APPENDIX C

EXTENSION OF MINORSKY'S ORIGINAL WORK TO THE  
LOW-ENERGY SHIP COLLISION REGION

As suggested by Norman Jones

C.1 APPLICATION OF MINORSKY'S METHOD TO A FULL ENCASTERED BEAM

Minorsky has suggested, Ref. (C1), that the energy absorbed in a collision can be related to a "resistance factor" thusly,

$$\text{where } E_T = 414.5 R_T + 121900 \quad (\text{Ton-knot}^2) \quad (1)$$

$$E_T = \text{energy absorbed in a collision (Ton-knot}^2)$$

$$R_T = \text{resistance factor or volume of material involved in a collision (ft}^2 \text{ - in)}$$

Results from Table 1 of Ref. (C2) suggest that for minor collisions the membrane energy in stiffened hull plating and stiffened decks is important, while other energies are less important.

By following Minorsky's general ideas but basing the energy absorption on the equations for beams loaded transversely into the membrane range, it was shown in the work of Ref. (C2) that the membrane energy of the deck and hull plating could be estimated using beam theory.

As an example, consider a fully damped beam with a span "2L" which is subjected to a concentrated load P at the mid-span. Accordingly, for a rigid perfectly plastic material with a yield stress  $\sigma_y$ , and from equation (23b) of Ref. (C3)

$$\frac{P}{P_c} = \frac{2w}{t}, \text{ when } \frac{w}{t} > 1.$$

w = displacement under load

$$\bar{P}_c = \frac{4}{L} \frac{(\sigma_y t^2 B)}{4} = \frac{(\sigma_y t^2 B)}{L}$$

B = beam breadth

t = beam thickness

2L = beam length

rectangular cross-section

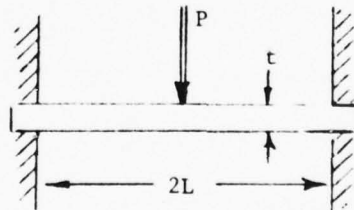

If the assumption is made that membrane behavior occurs at all displacements, the energy absorbed by the beam at displacement w is:

$$E = \int_0^w P dw = \int_0^w \bar{P}_c \frac{w}{t} dw = \frac{2\bar{P}_c w^2}{2t}$$

$$\text{or, } E = \frac{\sigma_y t^2 B w^2}{Lt} = \frac{\sigma_y t B w^2}{L} \quad (2)$$

Keeping in mind that Minorsky defines  $R_T = \text{volume of material} = \frac{2LBt}{144}$  for the above beam, we now have,

$$E = \frac{\sigma_y t B w^2}{L} \frac{R_T \cdot 144}{2LBt} = \frac{\sigma_y}{2} \left(\frac{w}{L}\right)^2 R_T \cdot 144$$

$$\text{or, } E = 72\sigma_y \left(\frac{w}{L}\right)^2 R_T \quad (3)$$

The units of the terms being:

$$R_T = \text{ft}^2 \text{in}$$

$$y = \text{lb/in}^2$$

$$w = \text{in.}$$

$$2L = \text{in.}$$

$$B, t = \text{in.}$$

But, Minorsky defines energy absorbed  $E_T$  in tons-knots<sup>2</sup> units. To achieve these units the following conversion is used:

$$E(\text{lb/in}) \cdot \frac{1}{2240} = \frac{E \text{ ton}}{2240} \text{ in} \quad (\text{using long tons})$$

$$\frac{E}{2240} \cdot 32.2 \cdot 12 \left(\text{ton} \frac{\text{in}^2}{\text{sec}^2}\right)$$

remembering that 1 knot = 20.25 in/sec

$$E_T = \frac{32.2 \cdot 12 E}{2240 \cdot (20.25)^2} \text{ ton knot}^2$$

$$E_T = \frac{32.2 \cdot 12}{2240 \cdot (20.25)^2} \cdot 72 \sigma_y \left(\frac{w}{L}\right)^2 R_T \quad (\text{Ton knot}^2)$$

$$E_T = 0.030288 \sigma_y \left(\frac{w}{L}\right)^2 R_T \quad (4)$$

For steel,  $\sigma_y = 30,000 \text{ lb/in}^2$ , then

$$E_T = 908.64 \left(\frac{w}{L}\right)^2 R_T \quad (\text{Ton knot}^2) \quad (5)$$

## C.2 INFLUENCE OF MATERIAL STRAIN HARDENING

If  $\sigma_u$  is the ultimate stress and  $\sigma_y$  the yield stress, then an estimate of the importance of strain hardening could be made using the average stress:

$$\sigma_a = \frac{\sigma_y + \sigma_u}{2} \quad (6)$$

in the equations (2) to (4).

### C.3 COMPARISON WITH EXPERIMENTS OF REFERENCE (C2)

It can be shown that the load-deflection ( $P - w$ ) relation used in this discussion with  $\sigma_a$  given by equation (6) is identical to equation (10) of Ref. (C2) when the load is at the mid-span. Thus the equations used to calculate the plastic energy in the last column of Table 3 in Ref. (C2) must be the same as equation (2) when using equation (6). It is evident from this table that quite good predictions are found for both flat and stiffened plates loaded at mid-span. This then forms the experimental basis for equations (4) - (6).

### C.4 N.C.R.E. FORMULA

From Ref. (C4), the energy absorbed in deck plating is

$$E = 0.9 \sigma_y T \{ \tan(\alpha/2) + .25 p^2 \} \quad (7)$$

where  $T$  is total thickness of decks

$\alpha$  is included angle of bow

$p$  is depth of penetration

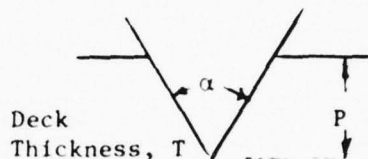

According to Minorsky's definition,

$$R_T = \left(\frac{P}{12}\right) \left(\frac{T}{12}\right) 2 p \tan(\alpha/2) \text{ (ft}^2\text{-in)}$$

therefore

$$E = 0.9 \alpha_y \{ \tan(\alpha/2) + 0.25 \} \frac{144 R_T}{2 \tan^2(\alpha/2)}$$

$$\text{or } E = 64.8 \sigma_y \left\{ 1 + \frac{0.25}{\tan(\alpha/2)} \right\} R_T \quad (\text{lb/in}) \quad (8)$$

To change to ton-knot<sup>2</sup>, the previous unit conversion is used again

$$E_T = 64.8 \sigma_y \left\{ 1 + \frac{0.25}{\tan(\alpha/2)} \right\} R_T \times \frac{32.2 \cdot 12}{2240 \cdot (20.25)^2}$$

$$\text{or } E_T = 0.02726 \sigma_y \left\{ 1 + \frac{0.25}{\tan(\alpha/2)} \right\} R_T \quad (\text{ton-knot}^2) \quad (9)$$

Again for steel,

$$\sigma_y = 30,000 \text{ lb/in}^2, \text{ and}$$

$$E_T = 817.78 \left( 1 + \frac{0.25}{\tan(\alpha/2)} \right) R_T \quad (\text{ton-knot}^2) \quad (10)$$

Two tables are shown below, the first of which, for three values of the "resistance factor",  $R_T$ , compares Minorsky's equation of absorbed energy, equation (1), with the NCRE equation of  $E_T$  with two values of wedge angle,  $\alpha$ . The yield stress  $\sigma_y$ , is for steel. The second table, again for  $\sigma_y$  of

steel, gives values of  $E_T$ , equation (5), relating the average displacement under load per length to the "resistance factor".

### C.5 CALCULATIONS

$R_T$ (ft <sup>2</sup> in)	Minorsky Equation (1) $E_T$ (ton kt <sup>2</sup> )	NCRE Equation (10) $y = 30,000$ lb/in <sup>2</sup>	
		$\alpha = 30^\circ$ $E_T$ (ton kt <sup>2</sup> )	$\alpha = 60^\circ$ $E_T$ (ton kt <sup>2</sup> )
1000	536400	1580779	11711884
2000	950900	3161558	2343778
3000	1365400	4742337	3515667

$R_T$ (ft <sup>2</sup> in)	Equation (5) $\sigma_y = 30,000$ lb/in <sup>2</sup>				
	$w/2L = \frac{1}{10}$	$w/2L = \frac{1}{5}$	$w/2L = \frac{1}{3}$	$w/2L = \frac{1}{2.5}$	$w/2L = \frac{1}{2}$
500	18173	72691	201920	290765	454320
1500	54518	218074	605760	872294	1362960
3000	109037	436147	1211520	1744589	2725920

### .5 CONCLUSIONS

Jones discussion in Ref. (C2) remarks that a plate ruptures when  $40'' < w < 50''$ , approximately, if  $2L = 150''$  (span),  $B = 30''$  (breadth),  $t = 1''$  (thickness),

$$\frac{w}{2L} \approx \frac{1}{3}$$

Noting this, equation (5) with  $\frac{w}{2L} = \frac{1}{3}$  is essentially parallel to Minorsky's equation (1).

Also note that equation (5) with  $\frac{w}{2L} = \frac{1}{2}$  is almost parallel to the NCRE formula with  $\alpha = 60^\circ$ .

For a given value of required energy absorption one could evaluate different designs (i.e., values of  $R_T$ ) from Figure (C1). This could also be done for designs which lie outside the shaded region. Perhaps only designs which lie to the left hand side of Minorsky's equation (1) could be considered acceptable.

Therefore, from the above, it can be seen that for minor collisions, it is necessary to specify  $w/2L$  which could be regarded as the average value of the maximum permanent displacements of the deck and side plating of a ship.

The influence of material strain hardening has not been considered in the following Figure (C1). However, equation (5) could be modified by using equation (6).

If a material has a yield stress  $\sigma_y$  and an ultimate stress  $\sigma_u$ , then the results predicted by equation (5) in Figure (C1) should be multiplied by  $(\frac{\sigma_y + \sigma_u}{2 \cdot 30000})$ .

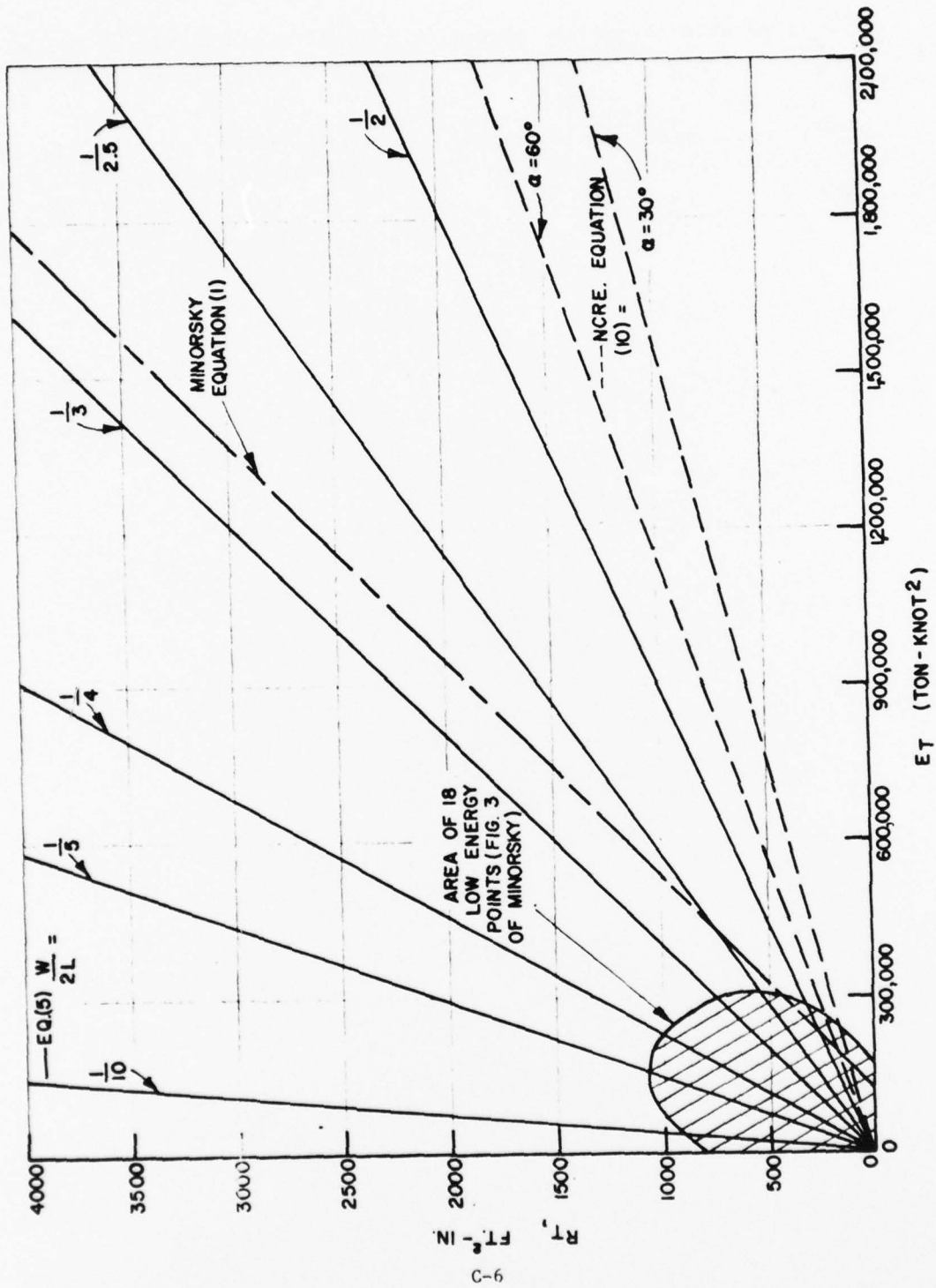
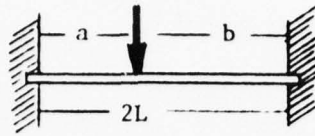

Figure C-1 Resistance to Penetration vs Energy Absorbed in Collision

C.6 VAN MATER'S EXTENSION TO JONES' SUGGESTED PROCEDURE

Consider the effect of a concentrated load at variable location on a fully encastered beam.



From Haythornwaite, Ref. (C5), using Jones' notation:

$$P_c = \frac{2 M_o (2L)}{ab} \qquad M_o = \sigma_y \frac{Bt^2}{4},$$

$$\frac{P}{P_c} = \frac{2w}{t}, \quad \left(\frac{w}{t} > 1\right)$$

Substitution gives

$$P_c = \sigma_y \frac{Bt^2}{2} \left(\frac{1}{a} + \frac{1}{b}\right) \qquad (11)$$

For  $a = b = l$  this reduces to Jones' expression.

For the load at variable location,

$$P_c = P_{cL} \cdot \frac{L}{2} \left(\frac{1}{a} + \frac{1}{b}\right)$$

Define  $\beta = \frac{L}{2} \left(\frac{1}{a} + \frac{1}{b}\right) = \frac{1}{b} \left(\frac{1}{a/2L}\right) \left(\frac{1}{b/2L}\right) \qquad (12)$

Since  $E = P_c \frac{w^2}{t}$  (Jones)

then to obtain the energy absorbed by the beam under a load at variable location we simply multiply the center load energy by  $\beta$ .

$$E_{(a,b)} = E_{cL} \cdot \beta \qquad (13)$$

$\frac{a}{2L}$	$\frac{b}{2L}$	$\beta$
.05	.95	5.26
.10	.90	2.78
.20	.80	1.56
.30	.70	1.19
.40	.60	1.04
.50	.50	1.00

Thus for a given displacement and span greater energy is absorbed by the beam for off center loads. Of course, as the load moves off the center then the strain in the short leg will be proportionately greater and rupture will occur at smaller  $w$ .

Next, we will use McDermott, Ref. (C6), to approximate a limiting  $w$ .

McDermott gives two criteria for failure of a stiffened beam. In our notation the first criterion is:

$$w = \sqrt{\frac{2ab}{2L} (a \epsilon_a + b \epsilon_b) + \delta_{bc}^2} \quad (14)$$

where  $\epsilon_a, \epsilon_b$  = strain in legs a, b

$\delta_{bc}$  = maximum value of deflection during bending phase.

From inspection of Table VII of Ref. (C6) take

$$\delta_{bc} = .15w$$

For an approximate treatment to determine the relationship between  $\epsilon_a$  and  $\epsilon_b$  we will consider geometric compatibility only. For a more rigorous treatment static compatibility must also be considered. Assume leg a is the short leg.

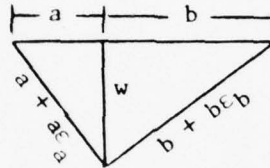

$$a^2 (\epsilon_a + 1)^2 - a^2 = w^2 = b^2 (\epsilon_b + 1)^2 - b^2$$

which leads to,

$$\epsilon_b^2 + 2\epsilon_b = \{\epsilon_a^2 + 2\epsilon_a\} \left(\frac{a}{b}\right)^2$$

For ABS steels rupture will occur when a limiting value of strain,  $\epsilon = .10$  is reached. Since the strain in leg a will be greater than that in leg b,

$$\epsilon_a = .10, \epsilon_a^2 = .01$$

$$\epsilon_b < \epsilon_a, \epsilon_b^2 = \text{negligible.}$$

$$\text{Then, } \epsilon_b = \frac{1}{2} \{ .01 + 2 \times .01 \} \left(\frac{a}{b}\right)^2$$

or approximately

$$\epsilon_b = \frac{1}{10} \left(\frac{a}{b}\right)^2$$

$$\epsilon_a = \frac{1}{10}$$

Substituting in (12) gives

$$w = \sqrt{\frac{2ab}{2L} \left( \frac{a}{10} + \frac{b^2}{10} \left( \frac{a}{b} \right)^2 \right) + \delta_{bc}^2}$$

$$w^2 = \frac{ab}{10L} \left( a + \frac{a^2}{b} \right) + (.15 w)^2$$

$$.98w^2 = .20 a^2$$

$$w = .452 a \tag{15}$$

This result contains many oversimplifications but still suggests a strong tendency toward linearity in the limiting displacement at rupture. From this result we may also infer that, at rupture,

$$\frac{w}{2L} = .452 \left( \frac{a}{2L} \right) = .452 (.5) = .226$$

Rewriting (2),

$$E_{\xi} = \sigma_y \cdot 4LBt \cdot \left( \frac{w}{2L} \right)^2$$

and incorporating (13)

$$E_{(a,b)} = \sigma_y \cdot 4LBt \cdot \left( \frac{w(a,b)}{2L} \right)^2 \cdot \beta$$

$$\frac{E_{(a,b)}}{E_{\xi}} = \frac{\left( \frac{w(a,b)}{2L} \right)^2}{\left( \frac{w}{2L} \right)^2} \cdot \beta \tag{16}$$

Now,  $\frac{w(a,b)}{2L} = .452 \frac{a}{2L}$ ,  $\frac{w}{2L} = .452(.5)$ , and  $\beta = \frac{1}{4} \left( \frac{1}{a/2L} \right) \left( \frac{1}{b/2L} \right)$

After substitution (16) reduces to

$$\frac{E_{(a,b)}}{E_{\xi}} = \frac{a/2L}{b/2L} = \frac{a}{b}$$

$$E_{(a,b)} = E_{\xi} \cdot \frac{a}{b} \tag{17}$$

Again, this result contains many oversimplifications but it shows clearly that a stiffened panel between bulkheads will absorb much less energy before rupture as the strike point moves away from the center span.

Finally, let us plot the McDermott data on a Minorsky plot. McDermott tested two section shapes, a flat plate and a flat plate stiffened by an inverted angle.

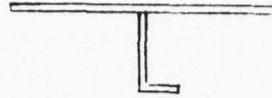
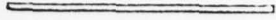

$$b = 6 \text{ in}$$

$$\text{Area} = 1.188 \text{ in}^2$$

$$t = \frac{1.188}{6.00} = .198 \text{ in}$$

$$b = 6.00 \text{ in}$$

$$\text{Area} = 1.471 \text{ in}^2$$

$$t_{av} = \frac{1.471}{6.00} = .245 \text{ in}$$

We will adopt a variation on Jones' definition of  $R_T$ :

$$R_T = w \times 2L \times t$$

where  $w$  = displacement at rupture  
 $2L$  = distance between supports  
 = 30 in for McDermott tests  
 $E_T$  = area under load-displacement curve. Conversion factor following Jones: ton-knot<sup>2</sup> = .4206 x kip-in.

TEST NO.	SECTION	LOAD LOCATION a/2L	w	$R_T$	$E_T$
1	flat plate	.5	9.70"	.400	164
2	stiffened plate	.5	10.23	.522	230*
3	stiffened plate	.5	4.47	.228	40
4	stiffened plate	.4	7.73	.395	151
5	flat plate	.5	4.81	.200	33
6	stiffened plate	.5	8.11	.414	145
8	stiffened plate	.167	3.69	.188	54
9	stiffened plate	.2	6.32	.323	80*
10	flat plate	.10	1.88	.078	18

\* $E_T$  based on equation (10) of Ref. (C6). See Table 3 of Ref. (C6).

Results are plotted in Figure C2 together with lines from the Jones formula. Note that the slope of the data band falls between  $\frac{w}{2L} = \frac{1}{2}$  and  $\frac{1}{\Delta}$ .

### C.7 DISCUSSION

The approach taken by both Jones and Van Mater is certainly an oversimplification of circumstances that would prevail in an actual collision. Still the results suggest that there is hope for the development of a simple Minorsky-type relation which would permit the prediction of the depth of incursion at shell rupture for a given input in collision Kinetic energy within reasonable upper bound error. The analyses used by Jones and Van Mater are intended simply to demonstrate feasibility of the approach, but there is a vast margin for refinement and improvement.

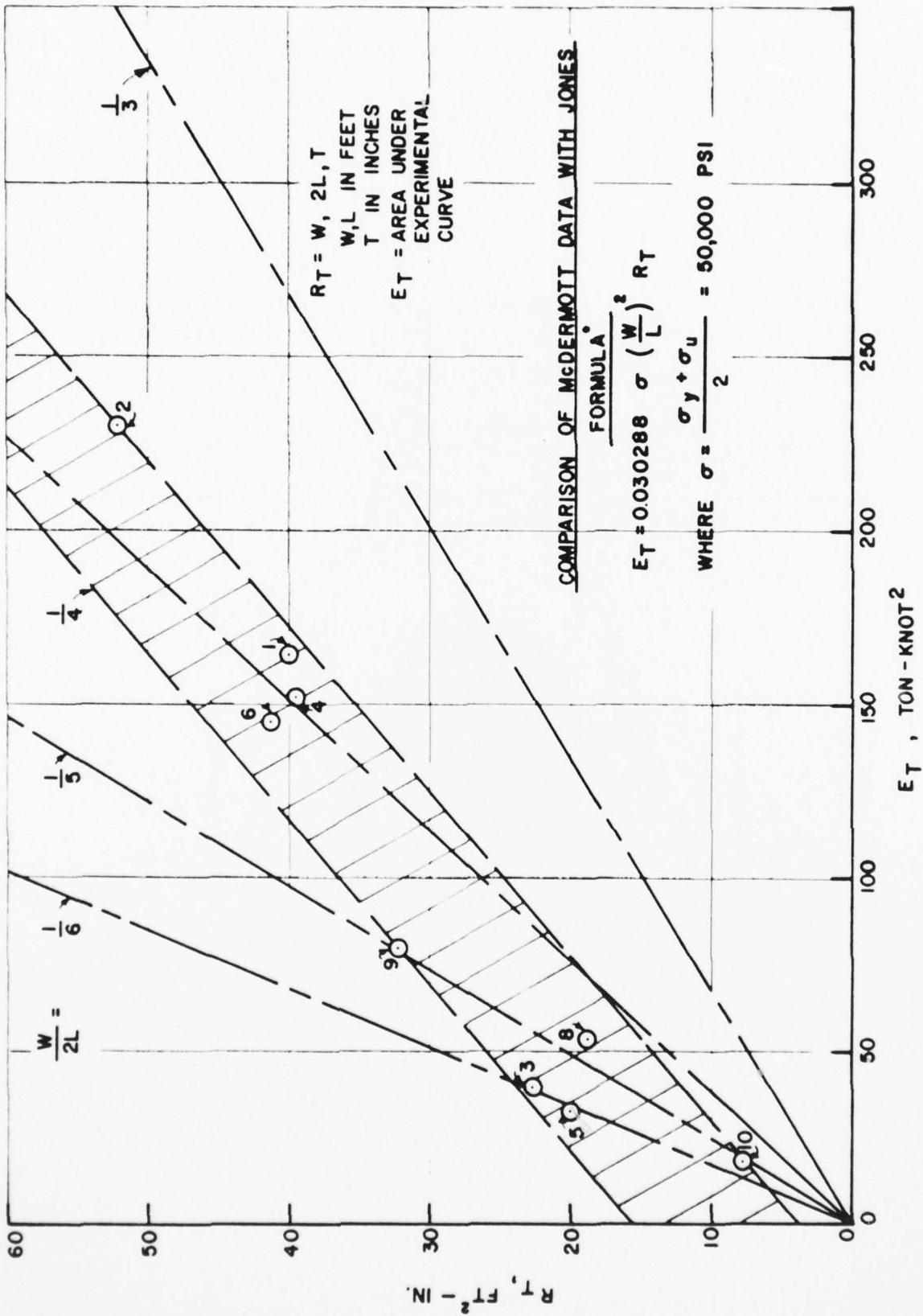

Figure C2. Comparison of McDermott Data with Jones' Formula

To refine the method will require a substantially greater body of experimental information including further tests of the McDermott type on a wider variety of section shapes, load locations, etc. Some tests should include simplified ship side shell and bow structures, and some tests should be dynamic to test the validity of the quasi-static approach.

#### REFERENCES

- C1. Minorsky, V., Journal of Ship Research, 1959, pp. 1-4.
- C2. McDermott, Kline, Jones, Manias, Chiang, SNAME Transactions, 1974, pp. 382-414.
- C3. Jones, N., International Journal of Mechanics and Science, 1973, Vol. 15, pp. 547-561.
- C4. Jones, N., Nuclear Engineering Design, 1976, Vol. 38.
- C5. Haythornthwaite, R. M., "Beams with Full End Fixity," Engineering, January 25, 1957, pp 110 - 112.
- C6. McDermott, J. F., et al, "Tanker Structural Analysis for Minor Collisions," Trans. SNAME, 1974, Vol 82.

## APPENDIX D

### CRITICAL REVIEW AND ASSESSMENT BY PROFESSOR NORMAN JONES OF THE ASSUMPTIONS IN THE ROSENBLATT METHOD

#### D.1 BACKGROUND

In order to obtain a separate, independent assessment of the various assumptions made in the Rosenblatt method, Professor Jones of M.I.T. was asked to review and comment on these assumptions. A summary of his contribution is presented here. All page and figure numbers referred to by Professor Jones correspond to the report entitled "Tanker Structural Analysis for Minor Collisions," which is listed as reference (2) in the main body of this volume or to Appendix C of this volume which presents a proposed extension of Minorsky's work.

#### D.2 REVIEW AND ASSESSMENT OF THE M. ROSENBLATT METHOD ASSUMPTIONS

The general procedure developed in the report is a sensible one and I think a valid approach to the problem of minor ship collisions. It does have various limitations, as we have discussed and as remarked below, and one may quibble over some of the details. However, I believe that it is a useful framework which could be built upon and computerized. Incidentally, minor collisions are defined as those which cause extensive denting and plastic deformations which do not cause rupture. However, the collisions must be sufficiently severe to ensure that elastic effects are negligible.

(1) An important restriction in the Rosenblatt method is the fact that it does not account for the possibility of fracture of the plating prior to the attainment of the ductility limit.

In this regard, it might be noted that Akita, Ando et al. (Nuc. Eng. Des. 19, 365-401, 1972) identified two types of fracture in idealised side structures impacted by rigid bows. Deformation type occurs when the strain ( $\epsilon$ ) directly below the loading point is less than  $\epsilon_b$ , while crack type behavior occurs when  $\epsilon > \epsilon_b$ . The quantity  $\epsilon_b$  is an experimental constant and the model tests suggest  $\epsilon_b = 0.3$ . This value of strain is similar to the engineering fracture strain of mild steel so that the crack-type behavior occurs at the ductility limit of the material and is therefore not related to unstable crack propagation, which would be predicted by a fracture mechanics study.

The Rosenblatt method also includes a ductility limit but no consideration is given to unstable crack propagation. Unfortunately, it would not be a simple task to include this feature in the Rosenblatt method (or any method for that matter) since the influence of material plasticity must be considered. No simple procedures for predicting

the unstable crack propagation of elastic-plastic bodies are currently available, and time-consuming and expensive numerical schemes must be used. Actually, this area is one in which many questions remain unanswered and a number of studies are currently probing various features of the phenomenon.

A very simple procedure for predicting the failure of ductile beams loaded dynamically was presented in Trans. A.S.M.E., J. Eng. Ind., Vol. 98B, 131-136, 1976. This theoretical method examined tensile tearing of beams and shear failure and surprisingly good agreement was obtained with some experimental tests. These general ideas do not, however, involve fracture mechanics, nor have they been used to examine static problems.

Even though it would be difficult to consider fracture mechanics, it would, nevertheless, be very worthwhile to attempt to refine the expressions for the strains at the hard points so that rupture might be more accurately predicted at these locations. (See p. 5-3 for some remarks on this important point.)

(2) The Rosenblatt method assumes that a striking bow is rigid so that any plastic energy which may be absorbed in a bow is disregarded. Also ignored is any destructive capability that a striking bow may possess.

The plastic-energy absorption of a bow could be estimated by considering the behavior of the individual members. However, unless some drastic simplifications were to be made (e.g., those of Minorsky or an N.C.R.E. type procedure), then the amount of analysis would probably be comparable to that already undertaken in the Rosenblatt report for a struck ship. The destructive capacity of a bow on the side shell of a struck ship would be much more difficult to predict. Another difficulty would be partitioning the total energy absorbed in a ship collision between a struck ship and the bow of a striking ship. However, this latter difficulty could probably be overcome by estimating the magnitude of the total force responsible for damage to the struck ship and equating it to the resultant total force acting on a striking bow. It is then conceivable that the areas of damage on struck and striking ships will not match so that some iterative scheme might be required.

In order to remain consistent with the struck-ship analysis in the Rosenblatt report, the proposed bow analysis should also be quasistatic and not dynamic.

(3) The proposed extension of Minorsky's method for minor ship collisions (see Appendix C of this volume) is a simple procedure which might be useful for estimating the behavior of ships involved in minor collisions. It contains a development of the basic relationship

(equation (5)) which is compared on a  $R_T$  vs  $E_T$  plot with the Minorsky and N.C.R.E. formulae.

In Appendix C, it is remarked that a test specimen examined by McDermott et al. (Trans. S.N.A.M.E. (1974)) ruptured when  $W/2L \approx 1/3$ . ( $W$  = maximum displacement,  $2L$  = span.) It is interesting to note from the  $R_T$  vs  $E_T$  plot that the theoretical predictions of equation (5) with  $W/2L = 1/3$  are similar to Minorsky's empirical relation (equation (1)). Thus, equation (5) with  $W/2L = 1/3$ , or Minorsky's equation (1), may be considered to provide an upper bound on the energy absorbed ( $E_T$ ) for a given resistance factor  $R_T$  (volume of material participating in a collision). Thus, equation (5) with  $W/2L < 1/3$  provides an estimate of minor damage which is manifested as dented plating and bent decks on the struck ship. Incidentally, minor collisions are not necessarily restricted to the shaded region in the  $R_T$  vs  $E_T$  plot. It would appear that collisions related to a larger value of  $R_T$  could also be classed as minor provided  $E_T$  is less than the corresponding values predicted by Minorsky or equation (5) with  $W/2L < 1/3$ .

The method is obviously tentative but I feel that it might prove useful for ranking and comparing minor collisions, just as Minorsky's has been for major collisions.

It might be interesting to estimate the values of  $R_T$  for the six collision cases examined in the Rosenblatt report on page 4-1 and plot the results on the  $R_T$  vs  $E_T$  plot. Hopefully, they would lie to the left hand side of Minorsky's formula and near equation (5), with  $W/2L = 1/3$ .

(4) Assumption 11 on page 3-9 of the Rosenblatt report is an important one which does not appear to have sufficient support. It is assumed that plastic strains equal to one-half the strains at the ends of the damaged length occur in the stiffened hull within the web frame space just beyond the damaged length. Now the plastic energy due to membrane strains in the stiffened hull dominates the energy balance as shown in the table of page 4-9. Thus, this assumption presumably is responsible for a significant membrane energy absorption, particularly when only one or two web frame spaces are involved in a collision.

I assume that assumption 11 is based on the observation made on page 6-21, which in turn is based on the experiments conducted using the test rig illustrated on page 6.3. It is not clear whether this arrangement faithfully reproduces the behavior of a plate in a ship. There are some doubts in my mind concerning the flexibility of the system. Are there any other independent tests to support assumption 11? How much would the theoretical predictions change if the plastic energies in the end spans were ignored?

(5) Equation (3-5) on page 3-20 of the Rosenblatt report is used in a number of places in the theoretical analysis (e.g., pp. 3-25, 3-26 and 3-27). This relation is developed for small rotations and displacements. In fact, this assumption might not be satisfied even for some minor collisions, since  $W/2L$  can reach  $1/3$ , as remarked in (3) here. It appears unnecessary to make this approximation and either the exact relation could be used or an additional term retained in the series expansion. The same remarks also apply to the equilibrium equation (3-6) on page 3-29.

(6) How sensitive is the theoretical analysis in the Rosenblatt report to the factor 1.5 on p. 6-28 which is used to provide an upper limit on the value of  $\epsilon_m$  given by equation (6-4) (on page 6-25) to the tensile test ductility?

(7) The types of collisions which might be studied using the Rosenblatt method are restricted, as discussed in item 5 on page 3-3. In order to broaden this class of collisions, any plastic-energy absorption in the bottom of a struck ship, in the transverse bulkheads or in the bilge strake, could be estimated by considering the plastic behavior of these individual components due to the imprint of a striking bow. It is remarked on page 5-4 that, in certain collisions, the strains in the bilge area are primarily longitudinal membrane strains. This leads to the possibility of important energy absorption in the bilge area.

(8) A number of assumptions have been made in the development of equations (2-1) to (2-7) which are not stated in the report:

- (a) The tangent modulus ( $E_t$ ) on page 2-14 is assumed to be constant.
- (b)  $M_p/M_o = \sigma_y/\sigma_u$  on page 2-15 does not appear to be strictly correct. For a rectangular cross-section, for example,

$$\frac{M_p}{M_o} = \frac{\sigma_y t^2}{4 \left\{ \frac{\sigma_y t^2}{4} + \frac{(\sigma_u - \sigma_y) t^2}{2 \cdot 3} \right\}}$$

when assuming linear strain hardening (i.e.,  $E_t$  constant as in (a) above) and using simple moment-equilibrium considerations. Thus  $M_p/M_o = 3\sigma_y/(\sigma_y + 2\sigma_u)$  which

approaches the value in the report only when  $\sigma_y \approx \sigma_u$  (i.e.,  $E_t > 0$ ). What is the value of  $M_p/M_0$  for other cross-sections? It appears unnecessary to make this approximation since the analysis would not be any more difficult using the correct value of the ratio.

- (c) There are many other assumptions peppered throughout pages 2-14 to 2-16 and they need to be constantly reviewed in the light of new experimental results as they become available.

(9) I have only had enough time to concentrate my attention on the right-angle collision case and I have not studied the details of the oblique collision case in the Rosenblatt report. It appears that the energy expressions developed for a travelling yielded zone on p. 2-16 are only used in the analysis of oblique collisions. Merely multiplying the expression on the top of page 2-17 by 2.0 to account for the plastic energy consumed in straightening appears to be a crude approximation. The Bauschinger effect is ignored, despite the fact that it may be important for the large strains involved in ship collisions. What about the influence of residual stresses? After all, it is impossible to achieve an unloaded state (zero moment) when the bar is unloaded to a zero curvature (straight). It would, therefore, appear worthwhile to examine the validity, or otherwise, of the factor 2.0 used on page 2.17.

Finally, I do believe, as I said at the outset, that the theoretical method developed in the Rosenblatt report provides a useful framework for the future study of minor ship collisions. Equation (5) in the accompanying report might or might not be useful as a crude aid in the preliminary design of protective structures involved in hypothetical minor collisions. It might also prove useful for ranking the collision protective capability and margin of survivability of different ships.

SHIP RESEARCH COMMITTEE  
Maritime Transportation Research Board  
National Academy of Sciences-National Research Council

\*\*\*\*\*

The Ship Research Committee has technical cognizance of the interagency Ship Structure Committee's research program:

Mr. O. H. Oakley, Chairman, *Consultant, McLean, VA*  
Mr. M. D. Burkhart, *Naval Oceanography Division, Department of the Navy, Washington, D.C.*  
Dr. J. N. Cordea, *Senior Staff Metallurgist, ARMCO INC., Middletown, OH*  
Mr. D. P. Courtsal, *Vice President, DRAVO Corporation, Pittsburgh, PA*  
Mr. W. J. Lane, *Consultant, Baltimore, MD*  
Mr. A. C. McClure, *Alan C. McClure Associates, Inc., Houston, TX*  
Dr. W. R. Porter, *Vice Pres. for Academic Affairs, State Univ. of N.Y. Maritime College*  
Prof. S. T. Rolfe, *Civil Engineering Dept., University of Kansas*  
Mr. R. W. Rumke, *Executive Secretary, Ship Research Committee*

\*\*\*\*\*

The Ship Design, Response, and Load Criteria Advisory Group prepared the project prospectus, evaluated the proposals for this project, provided the liaison technical guidance, and reviewed the project reports with the investigator:

Mr. W. J. Lane, Chairman, *Consultant, Baltimore, MD*  
Prof. A. H.-S. Ang, *Dept. of Civil Engineering, University of Illinois*  
Prof. S. H. Crandall, *Dept. of Mech. Engrg., Massachusetts Inst. of Technology*  
Mr. L. R. Glostén, *L. R. Glostén Associates, Inc., Seattle, WA*  
Mr. P. M. Kimon, *EXXON International Company, N.J.*  
Dr. O. H. Oakley, Jr., *Project Engineer, GULF R&D Company, Houston, TX*  
Prof. R. H. Scanlan, *Dept. of Civil & Geological Engrg., Princeton University*  
Prof. H. E. Sheets, *Chairman, Dept. of Ocean Engrg., Univ. of Rhode Island*  
Mr. J. E. Steele, *Naval Architect, Quakertown, PA*

\*\*\*\*\*

## SHIP STRUCTURE COMMITTEE PUBLICATIONS

*These documents are distributed by the National Technical Information Service, Springfield, Va. 22151. These documents have been announced in the Clearinghouse journal U. S. Government Research & Development Reports (USGRDR) under the indicated AD numbers.*

- SSC-272, *In-Service Performance of Structural Details* by C. R. Jordan and C. S. Cochran. 1978. AD-A057212.
- SSC-273, *Survey of Structural Tolerances in the U.S. Commercial Ship-Building Industry* by N. S. Basar and R. F. Stanley. 1978. AD-A057597.
- SSC-274, *Development of an Instrumentation Package to Record Full-Scale Ship Slam Data* by E. G. U. Band and A. J. Euler. 1978. AD-A059549.
- SSC-275, *The Effect of Strain Rate on the Toughness of Ship Steels* by P. H. Francis, T. S. Cook, and A. Nagy. 1978. AD-A059453.
- SSC-276, *Fracture Behavior Characterization of Ship Steels and Weldments* by P. H. Francis, T. S. Cook, and A. Nagy. 1978. AD-A058939.
- SSC-277, *Original Radar and Standard Tucker Wavemeter SL-7 Containership Data Reduction and Correlation Sample* by J. F. Dalzell. 1978. AD-A062394.
- SSC-278, *Wavemeter Data Reduction Method and Initial Data for the SL-7 Containership* by J. F. Dalzell. 1978. AD-A062391.
- SSC-279, *Modified Radar and Standard Tucker Wavemeter SL-7 Containership Data* by J. F. Dalzell. 1978. AD-A062393.
- SSC-280, *Results and Evaluation of the SL-7 Containership Radar and Tucker Wavemeter Data* by J. F. Dalzell. 1978. AD-A062392.
- SSC-281, *Bibliography for the Study of Propeller-Induced Vibration in Hull Structural Elements* by O. H. Burnside and D. D. Kana. 1978. AD-A062996.
- SSC-282, *Comparison of Stresses Calculated Using the DAISY System to Those Measured on the SL-7 Containership Program* by H. Y. Jan, K. T. Chang, and M. E. Wojnarowski. 1979.
- SSC-283, *A Literature Survey on the Collision and Grounding Protection of Ships* by N. Jones. 1979.
- SSC-284, *Critical Evaluation of Low-Energy Ship Collision-Damage Theories and Design Methodologies - Volume I - Evaluation and Recommendations* by P. R. Van Mater, Jr., and J. G. Giannotti. 1979.
- SSC-285, *Critical Evaluation of Low-Energy Ship Collision-Damage Theories and Design Methodologies - Volume II - Literature Search and Review* by P. R. Van Mater, Jr., and J. G. Giannotti. 1979.
- SSC-286, *Results of the First Five "Data Years" of Extreme Stress Scratch Gauge Data Collection Aboard Sea-Land's SL-7's* by R. A. Fain and E. T. Booth. 1979.