

AD-A070 721

BROWN (NEIL) INSTRUMENT SYSTEMS INC CATAUMET MA  
THREE AXIS ACOUSTIC CURRENT METER.(U)  
MAY 79

F/G 14/2

UNCLASSIFIED

N00014-75-C-0113  
NL

1 OF 3

AD  
A070721

This microfiche contains 140 frames of technical information for the Three Axis Acoustic Current Meter. The frames are arranged in a grid of 7 rows and 20 columns. The content includes:

- Technical drawings and diagrams of the instrument's internal components and external structure.
- Textual descriptions, specifications, and operational instructions.
- Tables of data and performance characteristics.
- Block diagrams and flowcharts illustrating the system's architecture and signal processing.

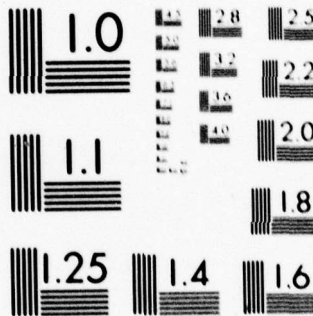

MICROCOPY RESOLUTION TEST CHART  
NATIONAL BUREAU OF STANDARDS-1963-A

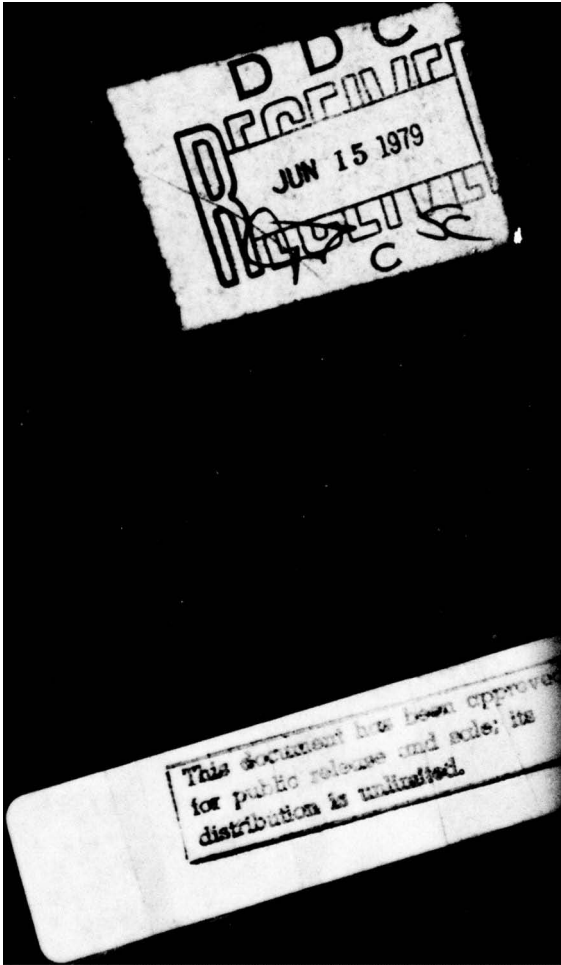

**NEIL BROWN INSTRUMENT SYSTEMS, INC.**

P.O. Box 498, 1140 Route 28A, Cataumet, MA 02534, USA (617) 563-9317

11 10 May 1979

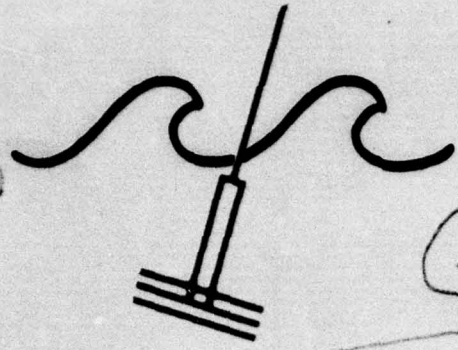

⑥ Three Axis Acoustic Current Meter

⑫ 242p.

DDC  
RECEIVED  
JUN 15 1979  
C

DA 070721

Dear Sir:

We enclose copies of a Final Report on work under Office of Naval Research contract N00014-75-C-0113 <sup>new</sup>

The report contains a brief description of the history of the contract work undertaken, together with reprints of studies evaluating results. The main body of the report is a technical discussion of the theory of acoustic current sensors and their practical application to oceanographic requirements. The embodiment of the results of the contract work in viable hardware is thoroughly documented.

Neil Brown Instrument Systems, Inc. wishes to thank the Office of Naval Research and its staff for the opportunity to participate in this work, and to express its gratitude to those many individuals whose interest and support was so graciously extended.

Yours sincerely,  
*Kenneth D. Lawson*  
Kenneth D. Lawson  
Vice President

KDL:jrp  
Enclosures

This document has been approved for public release and sale; its distribution is unlimited.

S/C 392 020

499 79 05 30 254

DDC FILE COPY

**Title: Three Axis Acoustic Current Meter**

FINAL REPORT: OFFICE OF NAVAL RESEARCH CONTRACT N00014-75-C-0113

In 1975 the Office of Naval Research granted contract N00014-75-C-0113 to Neil Brown Instrument Systems, Inc. During the first phase of this contract, design concepts and prototype hardware were generated, leading to a successful demonstration of the capabilities of an acoustic phase shift velocity sensor. Tests performed by Mr. James McCullough of the Woods Hole Oceanographic Institution and Mr. Gerald Appell of the National Oceanic and Atmospheric Administration proved the basic merit of the acoustic design and led to progressive refinements. A formal presentation of results derived from one embodiment of the design was made to the Instrument Society of America's International Instrumentation Symposium. A copy of this paper<sup>1</sup> is enclosed.

Success of the initial feasibility-study phase of this development program led to an extension of the scope of contract to include design and fabrication of sea-worthy moored current meters. Work to this end began in 1976 and led to production of three units configured to specific requirements of the NOAA National Data Buoy Office. These units were tested extensively by the Test and Evaluation Laboratory of NOAA. Results of this testing have been published.<sup>2</sup>

A somewhat more detailed discussion of the results of T & EL tests may be found in a paper delivered to the 1978 Working Conference on Current Measurement.<sup>3</sup> The three prototype current meters fabricated pursuant to contract have been repeatedly and successfully deployed by National Data Buoy Office. These deployments have proved the accuracy and reliability of the design and its suitability for use under arduous conditions. The successful outcome of the second phase of contract development encouraged Neil Brown Instrument Systems, Inc. to continue work on moored current meter design and was resulted in the instrument described within the body of this report. At least twenty of these units have undergone testing and deployment, with results which though preliminary, are extremely encouraging.

- 1 Lawson, K.D., Brown, N.L., Johnson, D.H., Matthey, R.A., A Three-Axis Acoustic Current Meter For Small Scale Turbulence, ISA ASI, pp. 501-508, 1976.
- 2 Appell, G.F., Performance Assessment of Advanced Ocean Current Sensors, IEEE J. of Ocean Eng., Vol. OE-4, No. 1, January, 1979.
- 3 Appell, G.F., A Review of the Performance of an Acoustic Current Meter, presented at the 1978 Working Conference on Current Measurement, Newark, DE, Jan. 11-13, 1978.

500

This document has been approved  
for public release and sale; its  
distribution is unlimited.

D D C  
REF ID: A66116  
JUN 15 1979  
C

A THREE-AXIS ACOUSTIC CURRENT METER FOR SMALL SCALE TURBULENCE

Kenneth D. Lawson, Jr.  
Senior Engineer  
Neil Brown Instrument Systems, Inc.  
Falmouth, Massachusetts

Neil L. Brown  
President  
Neil Brown Instrument Systems, Inc.  
Falmouth, Massachusetts

David H. Johnson  
Senior Staff Physicist  
Johns Hopkins University  
Laurel, Maryland

Robert A. Matthey  
Senior Staff Engineer  
Johns Hopkins University  
Laurel, Maryland

INTRODUCTION

Design on the current meter described in this paper began early in 1975 at Neil Brown Instrument Systems, Inc. (NBIS) and the Applied Physics Laboratory of Johns Hopkins University (APL/JHU) in an attempt to develop an instrument having characteristics suitable for horizontal profiling of small scale turbulence in the ocean. The result of this program was a three-axis instrument suitable for mounting on the bow of a submersible and capable of resolving turbulence phenomena as small as 10cm with frequency components up to 50Hz. Included in the overall instrument package was a conductivity - temperature - depth (CTD) system and three-axis accelerometer. The CTD sensor and electronics are described elsewhere<sup>1</sup>. During a single scan interval of .01s all three axes of the acoustic current meter, the three axes of the accelerometer, and the conductivity, temperature, and pressure sensors are digitized, resulting in 900 measurements every second. The accelerometer and velocimeter outputs are digitized to 14 bit and the CTD to 16 bit resolution. Figure 1 shows a block diagram of the overall system. This paper will be limited to a discussion of the three-axis acoustic current meter.

CURRENT METER CHARACTERISTICS

An examination of the characteristics of current meters in general leads to the conclusion that the mechanical types are generally quite unsuitable for this application. The Savonius<sup>2</sup> rotor's unequal acceleration and deceleration rates and non cosine response make it particularly unsuitable. The electromagnetic current meters have the disadvantage that their electrical output is proportional to magnetic field. This field decreases rapidly with distance from the coil. Consequently, they are sensitive only to fluid flow in the immediate vicinity of the coil which, due to its bulk, severely affects the flow being measured. The open Helmholtz coil E.M. current meter described by Olsen<sup>3</sup> could possibly be adapted to meet the stated requirements. The acoustic backscatter type<sup>4</sup> while appearing to have theoretically ideal characteristics has not been generally successful due to the poor distribution of suitable scatterers in clear ocean water.

Thus it was felt that current meters in which current is sensed by measuring the differential travel

time of acoustic signals travelling with and against the fluid flow offered better possibilities. The reasons are (1) response is inherently linear and extremely fast (2) sensitivity is uniform over the acoustic path (3) the transducers are small (4) signal to noise ratio is usually excellent (5) it can be made to have close to ideal cosine response (6) calibration can be inferred from frequency, sound velocity and transducer spacing.

Numerous acoustic current meters using this basic concept have been described in the literature. The concept has been implemented in a number of different ways some of which are (1) short pulse using 2 transmitters and 2 receivers for each axis<sup>5</sup> (2) short pulse using 2 transducers each acting as both a transmitter and receiver<sup>6</sup> (3) dual "sing-around" sound velocimeters with straight line sound paths in opposite directions (the difference in the "sing-around" frequency being a linear function of current.) (4) continuous wave using two widely different high frequency carriers (e.g. 1.1 and 1.6MHz, but modulated with an identical signal of lower frequency (e.g. 20kHz) where the phase difference of the modulating signal on the received carriers is a linear function of current velocity.<sup>8</sup> (5) continuous wave bursts using a single frequency (e.g. 2MHz) on a single pair of transducers, the burst interval being approximately equal the acoustic travel time between the two transducers.<sup>8</sup> The received bursts resynchronize "slave" oscillators which maintain phase information between bursts. The continuous output of the "slave" oscillators is heterodyned with a local oscillator resulting in outputs of 8kHz. Phase difference between the 8kHz signals is a linear function of current.

The first three methods require the measurement of arrival time differences of pulses with sufficient speed to resolve currents less than 1cm/sec. It can be shown that

$$\Delta T = \frac{2vd}{c^2}$$

where  $\Delta T$  = arrival time difference  
 $v$  = current velocity  
 $d$  = transducer spacing  
 $c$  = velocity of sound

For  $d = 4\text{cm}$ ,  $c = 1500\text{m/s}$ , the time difference is

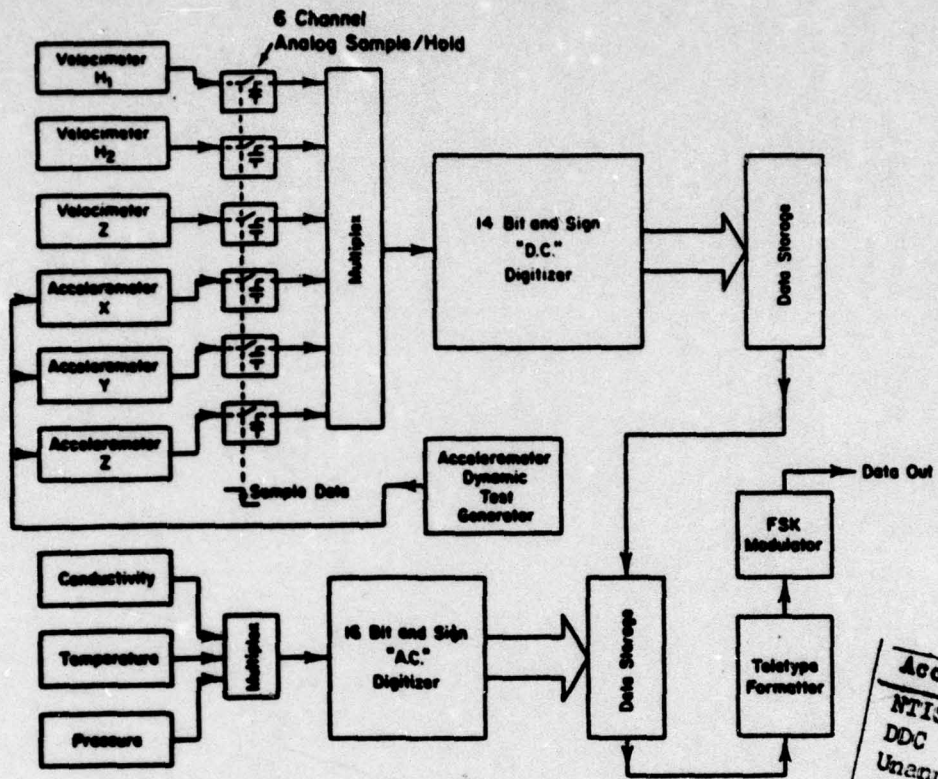

Fig. 1 System Block Diagram

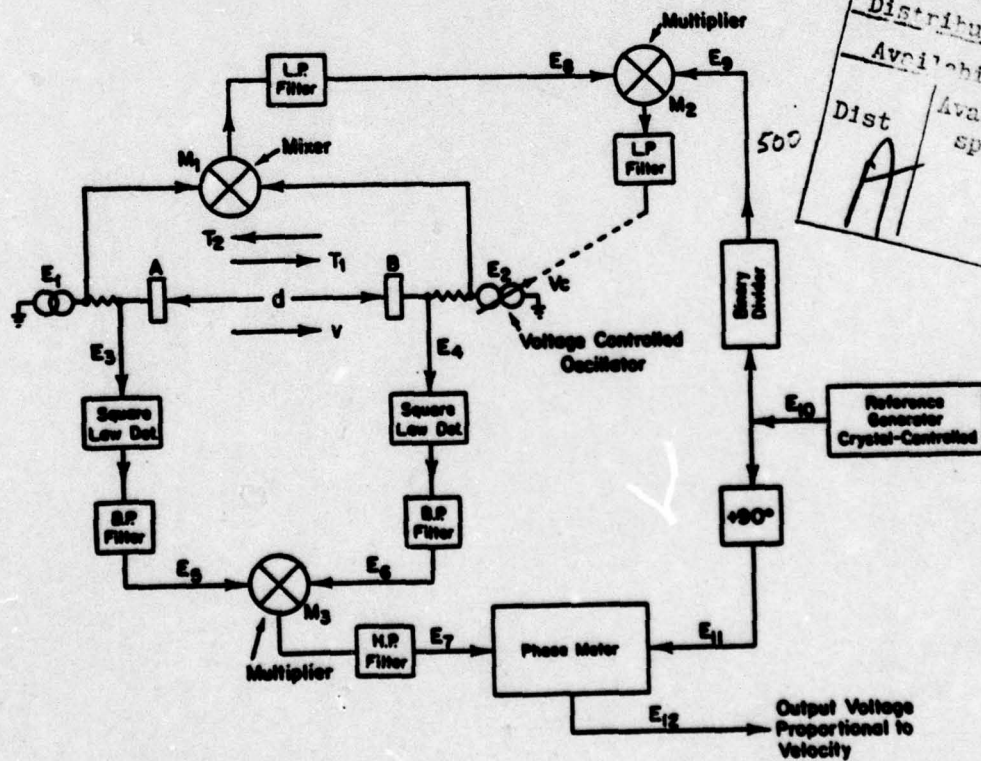

Fig. 2 Continuous Wave Concept

Accession For  
 NTIS GRA&I  
 DDC TAB  
 Unannounced  
 Justification  
 By *on file*  
 Distribution/  
 Availability Codes  
 Dist Avail and/or special  
 A

$3.6 \times 10^{-10}$ s. Time resolution as short as this requires extremely high speed circuitry and auto calibration features such as those described by Gytre<sup>6</sup>. The first method using separate transducers for receiving and transmitting suffers from the additional disadvantage of requiring extremely stable relative position between the receiver and transmitter of each pair. For example, a change in relative position of  $10^{-6}$ m for an acoustic path length of 4cm causes a change in arrival time equivalent to a current change of 2cm/s. The fourth method while free of the problems associated with threshold detection of pulses, etc. does require the measurement of phase difference to the same time resolution as types 1, 2 and 3 above. The fifth method has the advantage that the phase angle measured at the relatively low beat frequency is the same phase angle difference that occurs at the carrier frequency. This permits a time measurement that can be slower by the ratio of the carrier to the beat frequency for a given current speed.

#### CONTINUOUS WAVE CONCEPT

The continuous wave concept described in this paper is shown schematically in Figure 2. Each axis utilizes a single pair of transducers 4cm apart. Each transducer simultaneously transmits one frequency (approx. 2.7MHz) and receives another frequency (differing by 500Hz) acoustically from the other transducer. Since the signal sources driving the transducers are high impedance (essentially constant current) both frequencies exist simultaneously at each transducer. The composite signals at each transducer  $E_1$  and  $E_2$  (see Figure 2) are each square law detected and band pass filtered resulting in 500Hz beat frequency signals  $E_5$  and  $E_6$ . These signals are in turn multiplied in  $M_3$  resulting in a 1kHz signal  $E_7$  which forms one input to the phase meter. A 1kHz reference is the other input  $E_{11}$  to the phasemeter and is derived from a reference generator  $E_{10}$ . An examination of the theoretical discussion below shows that resulting output  $E_{12}$  from the phasemeter is a linear function of current, and that the required time resolution for an acoustic path length of 4cm and a current of 1cm is  $10^{-6}$ s. Thus, the required time resolution for this continuous wave concept is approximately 2750 times longer than that required for the pulse technique. This drastically simplifies the circuitry and results in an instrument that does not require the use of ultra high speed circuitry or the need to correct for changes in internal circuit delays due to temperature, etc. to achieve sensitivities and stabilities better than 1cm/s.

#### THEORY OF OPERATION

The following is a discussion of the theory of operation of one of the axes of the 3 axis current meter. For the Z axis  $E_1$  and  $E_2$  have frequencies of 2.7505 and 2.7500MHz respectively. The frequencies for the other two axes are 2.7700 and 2.7705MHz for  $E_3$  axis and 2.7300 and 2.7305MHz for the  $E_4$  axis. Different frequencies were used for each of the 3 axes to avoid possible interference between the different axes.

Referring to Figure 2,  $E_1$  is derived from a fixed crystal controlled oscillator having a frequency

of 2.7505MHz.  $E_2$  is derived from a voltage controlled crystal oscillator whose frequency is maintained by a phase locked loop at a frequency exactly 500Hz lower than  $E_1$  (i.e. 2.7500MHz). The phase-locked loop maintaining the phase of the beat frequency  $E_3$  at exactly  $90^\circ$  difference from the 500Hz reference frequency  $E_9$  which is derived via a binary divider from the 1kHz reference signal  $E_{10}$ .  $E_8$  and  $E_9$  are the inputs to a multiplier  $M_2$  whose output is low pass filtered resulting in a d.c. signal used to correct the phase error of  $E_2$  (crystal VCO) and, consequently, the phase error between  $E_3$  and  $E_9$ . Except for the additional mixer  $M_1$  and low pass filter  $LP_1$ , this circuit is a conventional phase-locked loop. The circuit parameters are such that the maximum phase error is less than .003 rad. The theory of operation is as follows.

$$E_1 = \cos \omega_1 t \dots \dots (2.7505\text{MHz from crystal oscillator})$$

$$E_2 = \cos \omega_2 t \dots \dots (2.7500\text{MHz from crystal VCO})$$

$$E_3 = \cos \omega_1 t + k_1 \cos (\omega_2 t + \omega_2 T_2)$$

$$E_4 = \cos \omega_2 t + k_2 \cos (\omega_1 t + \omega_1 T_1)$$

$$k_1 \text{ \& } k_2 = .002 \text{ (typical)}$$

$T_1$  and  $T_2$  are travel times from A to B and B to A. After mixing and removing zero and high frequency terms

$$\text{we get } E_5 = \frac{1}{2}k \cos ((\omega_1 - \omega_2)t - \omega_2 T_2)$$

$$\text{and } E_6 = \frac{1}{2}k \cos ((\omega_1 - \omega_2)t + \omega_1 T_1)$$

After mixing  $E_5$  and  $E_6$  in  $M_3$  and high pass filtering

$$\text{we get } E_7 = \cos(2(\omega_1 - \omega_2)t + \omega_1 T_1 - \omega_2 T_2)$$

$$E_8 = \cos(\omega_1 - \omega_2)t \quad (500\text{Hz output})$$

$$E_9 = \sin(\omega_1 - \omega_2)t \quad (500\text{Hz reference})$$

$$E_{10} = \sin 2(\omega_1 - \omega_2)t \quad (1\text{kHz reference})$$

$$E_{11} = \cos 2(\omega_1 - \omega_2)t$$

Therefore phase angle between  $E_7$  and  $E_{11}$  is

$$\theta = \omega_2 T_2 - \omega_1 T_1$$

$$\text{Now } T_1 = \frac{d}{c+v} \text{ and } T_2 = \frac{d}{c-v}$$

where  $d$  = acoustic path length  
 $c$  = velocity of sound  
 $v$  = component of current velocity parallel to acoustic path

Therefore

$$\theta = \frac{d}{c^2 + v^2} (c(\omega_1 - \omega_2) - v(\omega_1 + \omega_2))$$

$$\theta = \frac{d}{c} (\omega_1 - \omega_2) + \frac{vd}{c^2} (\omega_1 + \omega_2) \text{ since } c \gg v$$

The first term is in effect a "zero offset" term and the second term is the current velocity term. For  $d = 4\text{cm}$ ,  $c = 1.5 \times 10^3 \text{cm/s}$ , the relationship between  $\theta$  and  $v$  is given by

$$\theta = .0838 + .00614v \text{ rad/cm/s}$$

Thus, the zero offset term is equivalent to a velocity of 13.63cm/s. The d.c. output of the

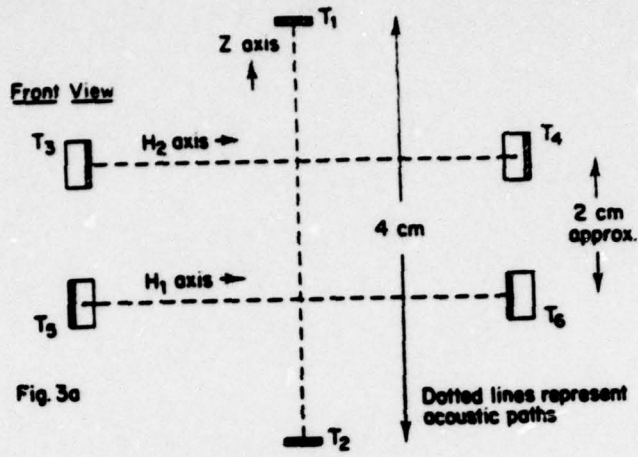

Fig. 3a

Fig. 3b

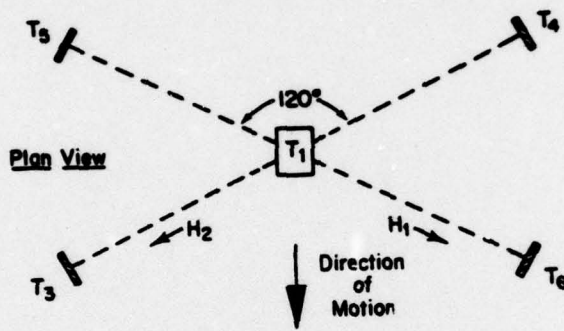

Fig 3 Transducer Array Schematic

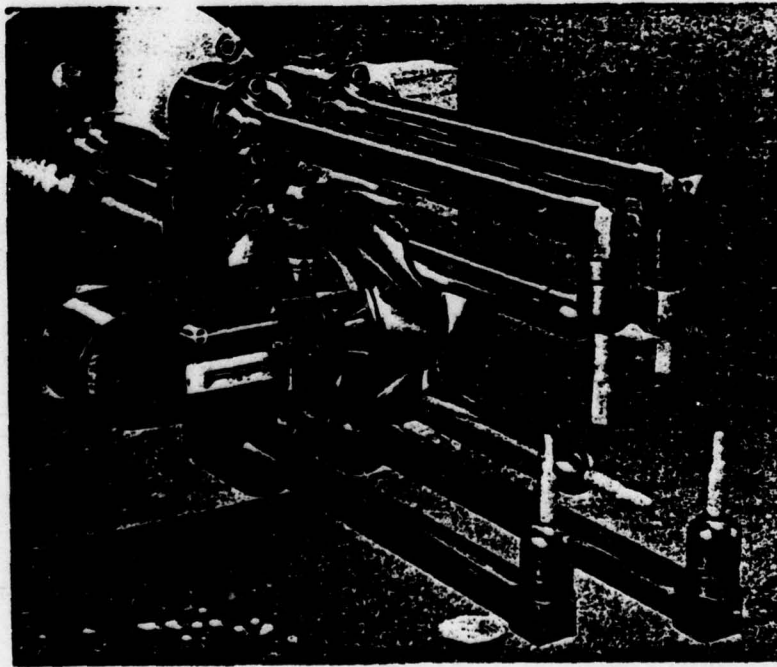
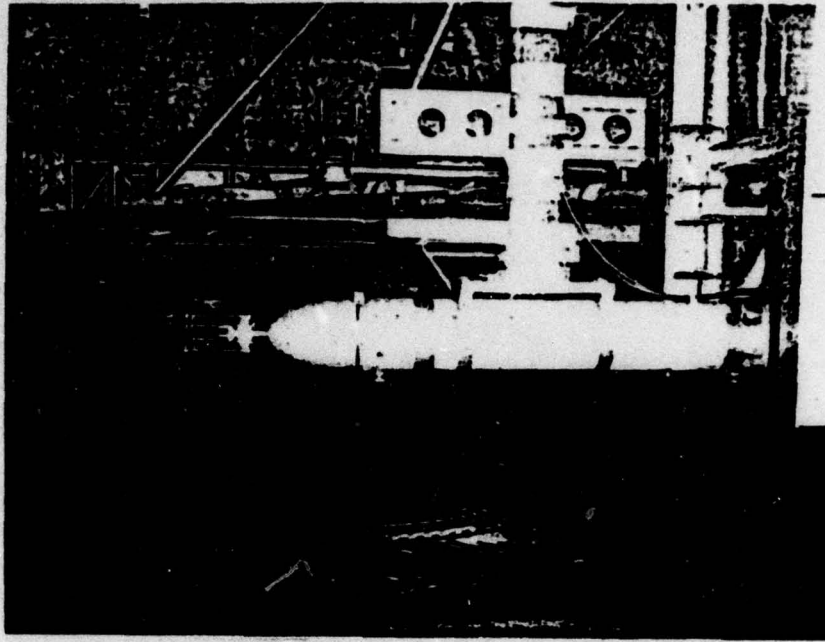
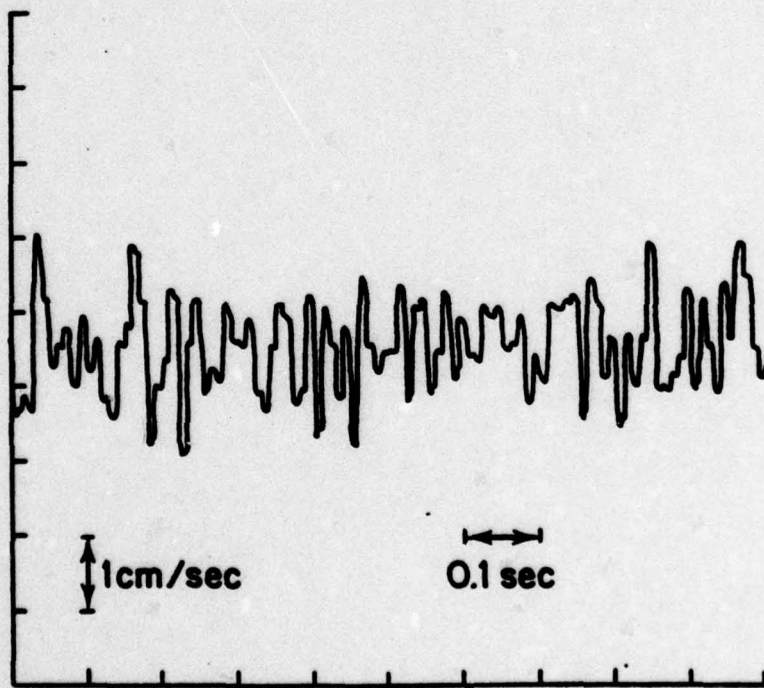

Fig.4 Velocimeter and CTD Transducers



**Fig.5 Tow Tank Test Rig**



**Fig.6 Wideband Noise**

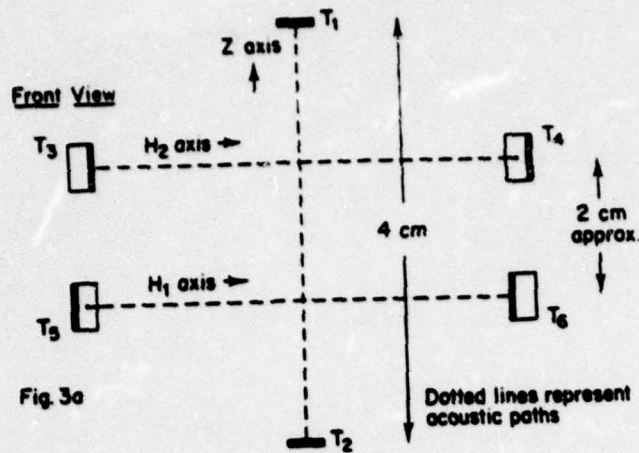

Fig. 3a

Fig. 3b

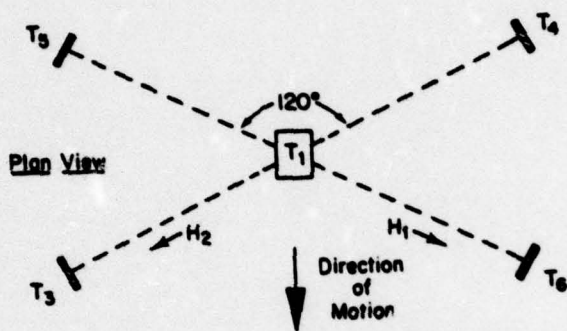

Fig 3 Transducer Array Schematic

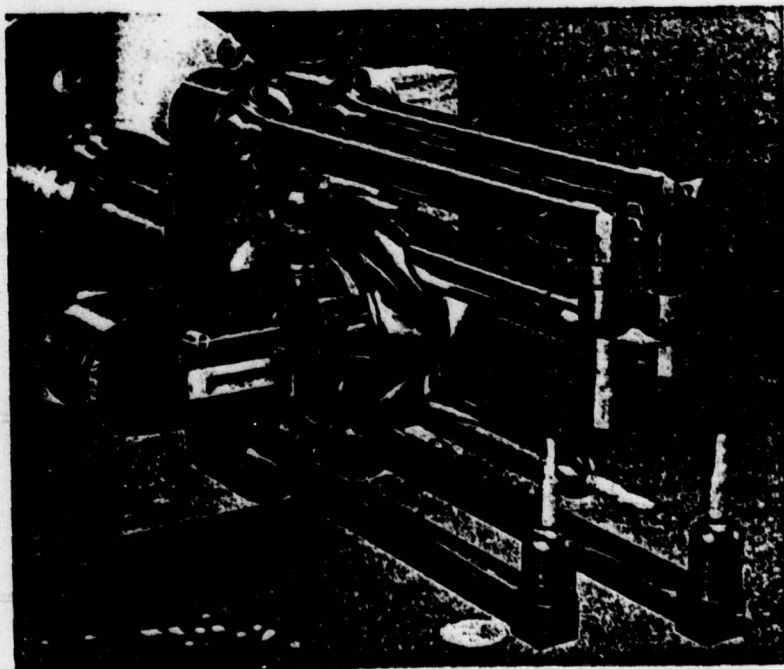

Fig.4 Velocimeter and CTD Transducers

phasemeter is thus a linear function of current velocity. The "zero offset" and the dependence on sound velocity are corrected numerically during data processing.

Since the zero offset term is proportional to the difference frequency ( $\omega_1 - \omega_2$ ) it could be reduced to an insignificant value by decreasing ( $\omega_1 - \omega_2$ ). However, this would also reduce the upper frequency response of the velocimeter.

#### TRANSDUCER ARRAY

Figure 3a and 3b show the spatial arrangement of the three axes of the current meter. The two horizontal axes  $H_1$  and  $H_2$  are at an angle of  $120^\circ$  and the plane of the  $H_2$  axis is displaced vertically from the  $H_1$  axis by about 2cm.

Since the forward motion of the submersible results in an incident current vector that is within  $30^\circ$  of the reference axis, this particular spatial arrangement ensures that no wake of any transducer crosses any of the acoustic paths thus resulting in minimal contamination of the measurements by the instrument itself:

Figure 4 shows a photograph of the three pairs of acoustic transducers and also the conductivity and temperature sensors of the conductivity - temperature - depth (CTD) system.

The transducers are fabricated from lead metaniobate slabs 0.7mm thick, 5mm high, and 2mm wide. They were mounted in alumina assemblies which in turn were bonded using fused glass to the cylindrical stem. This ceramic and glass housing had excellent mechanical stability and inertness to seawater. The piezoelectric material, lead metaniobate, was chosen for this application because it had a low temperature coefficient of dielectric constant, low mechanical Q and essentially no acoustic radiation from the sides of the slab. At 2.75MHz this resulted in an acoustic beam width of approximately  $8^\circ$  on one axis and  $20^\circ$  on the other.

#### PERFORMANCE TEST

Some aspects of the steady state performance of the instrument were determined using the David Taylor Naval Ship Research and Development Center's (DTNS RDC) Deep Water Towing Basin. Flow sensitivity, angular response in both pitch and heading up to angles of  $30^\circ$ , and the noise characteristics of the instrument were measured.

The Deep Water Towing Basin is 15.5m wide and 6.7m deep. The tank is divided in half by a bulkhead. The west end, used for this test, is about 457m long. The velocimeter assembly was mounted on a strut of a towing carriage and inserted to a depth of 3.4m. The carriage was operated at speeds of 103, 206, 309, and 514cm/s (of 2, 4, 6, and 10 kts) for these tests. It had an electrohydraulic drive which maintains these speeds within one cm/sec. A rack and pinion device with a magnetic pickup emits a pulse every 3m travelled by the carriage. The pulses are counted and stored in a memory which is sampled every 0.01s and recorded along with the

stream of data from the velocimeter.

Figure 5 shows the sensor package and mounting bracket. The sensor package was aligned with the Z axis vertical. The heading response of the velocity sensors was checked in this orientation at each carriage speed by rotating the assembly to  $0^\circ, \pm 30^\circ$  in the horizontal plane. Measuring the response at both positive and negative angles of incidence provided a check on the alignment of the transducers. The pitch response of the sensors was checked at each carriage speed by rotating the sensor package  $90^\circ$  about its axis to make the Y axis vertical and then rotating the assembly to  $0^\circ, \pm 15^\circ$ , and  $\pm 30^\circ$  in the horizontal plane. The possibility of asymmetries in the flow about the sensor assembly was checked by repeating each measurement discussed above, but with the sensor package rotated  $180^\circ$  about its longitudinal axis.

Table I shows the linear response of the horizontal transducers. Each has a zero offset with a magnitude larger than the theoretical. This discrepancy from offset errors in the electronics was not corrected for lack of time but is easily remedied. The response is linear to within  $\pm 1.1\%$  over the test range of 0 to 514cm/s (10 knots), but the sensitivity is lower than theoretically predicted by about 15%, probably due to a stagnation flow effect. A potential flow calculation, summing the effects of the elliptical fairing and flat base plate behind the array, predicts about a 10% flow reduction, independent of the carriage speed. Stagnation flow around the transducers themselves may contribute to the reduction.

TABLE I - VELOCIMETER RESPONSE

Carriage Speed (cm/s)	Velocimeter Reading* (cm/s)		Deviation** (%)	
	$H_1$ Axis	$H_2$ Axis	$H_1$ Axis	$H_2$ Axis
0	0.0	0.0	0.0	0.0
103	90.1	91.8	+0.1	+1.1
206	174.5	172.8	-0.9	-0.2
309	264.7	263.6	-0.6	+0.7
515	445.8	434.2	0.0	0.0

\*Velocimeter Reading corrected for zero offset

\*\*Deviation from best fit straight line thru end points

Figure 6 shows the wide-band (0-50Hz) noise of the vertical channel. The r.m.s. amplitude is about 0.3cm/s. Thus the noise is less than 0.1% of full scale over a 50Hz band-width. This is a very acceptable figure, but can be improved upon by better crystal design and mounting.

#### CONCLUSION

Preliminary test results show that the continuous wave acoustic current meter is very promising. The technique of heterodyning two very close frequencies

(at the transducers) allows excellent current resolution using conventional low power electronics since all the critical signal processing is done at the best frequency. The use of a single pair of transducers avoids errors due to small mechanical instabilities and differential phase responses that occur when separate transmitting and receiving transducers are used. Development of the concept is being continued at NBIS, Inc. and data analysis and evaluation at APL/JHU. Unfortunately, the publication deadline did not allow time for analysis and presentation of more complete test results in this paper.

The authors wish to thank Mr. C. Cotter and Mr. W. Lane of NBIS, Inc. and Mr. W. Venezia of APL/JHU for their excellent contribution, and the U.S. Navy who sponsored this program under NAV-SEA Contract No. W00017-72-C-4401.

#### REFERENCES

- (1) Brown, N.L., *A Precision CTD Microprofiler*, IEEE OCEAN 74 Conf. Engineering in the Ocean Environment, Vol 2 (August, 1974), 270.
- (2) McCullough, J.R., *In search of Moored Current Sensors*, MARINE TECH. SOC., 10th Annual Conf., September, 1974.
- (3) Olson, J.R., *Two-component Electromagnetic Flowmeter*, MARINE TECH. SOC. JOUR., Vol 6 (1972).
- (4) Kocsy, F.F., M. Kronengold and J.M. Loewenstein, *A Doppler Current Meter*, INST. SOC. OF AMER., MAR. SCI. INSTRUMENTATION, Vol 2 (1962).
- (5) Rester, G.F., and G.P. Erickson, *An Acoustic Oceanographic Current Meter*, INST. SOC. OF AMER., 26th Annual Conf., October, 1971.
- (6) Cytro, T., *Ultrasonic Current Meter*, Christian Michelson Inst. Report 377208, Bergen, Norway, January, 1975.
- (7) Suellettrop, F.J., A.E. Brown and E. Rule, *An Acoustic Ocean-Current Meter*, INST. SOC. OF AMER., MARINE SCIENCE INSTRUMENTATION, Vol 1 (September, 1961).
- (8) Lester, R.A., *High-Accuracy, Self-Calibrating Acoustic Flow Meters*, INST. SOC. OF AMER., MARINE SCI. INSTRUMENTATION, Vol 1 (September, 1961).

# Performance Assessment of Advanced Ocean Current Sensors

GERALD F. APPELL

**Abstract**—Laboratory tests were performed by NOAA/NOS's Test and Evaluation Laboratory (T&EL) on a new electromagnetic-type current sensor and a new acoustic-type current sensor. The simulation methods are described for attaining a performance description of the sensor's dynamic response and steady flow characteristics in the laboratory. Test results and data interpretation are discussed.

## I. INTRODUCTION AND BACKGROUND

**I**N A PAPER presented at the Ocean '77 Conference, McCullough [1] discusses the problems associated with the measurement of currents in the near-surface environment. He concludes, "We lack only the necessary tests needed to select optimum designs and establish their limitations." The objective of NOAA's Test and Evaluation Laboratory's (T&EL's) program is to assess the performance of sensors and/or subsystems over a realistic range of environmental conditions to establish their limitations and "bound" their errors. This objective makes the assumption that we can establish a "realistic range" of environmental conditions. Dynamic velocities are considered to be time-varying phenomena which are dependent on a multitude of environmental conditions and system designs. The resultant current velocity fluctuations can have a wide range of frequencies and may assume directions at any conceivable angle to the measurement platform. These dynamic velocities are the major "stumbling blocks" to realistic environmental simulation and accurate description of system performance.

In an attempt to simulate the dynamic environment, a test apparatus was constructed to dynamically move instrumentation through a wide range of motions. This apparatus [2] produces a variety of motions under controlled conditions such that the resultant time-varying vectors simulate velocity magnitudes and directions as may be encountered in the environment. The apparatus is utilized on the David Taylor Naval Ship Research and Development Center (DT-NSRDC) number one tow carriage. Analysis can be performed in real time or averaged to eliminate the simulated noise [3]. The motions produced are considered macroscale, that is, those imposed on instrumentation by wave dynamics directly or indirectly by platforms. Motions of up to 1.22-m amplitude with a 4-s period can be produced. Microscale noise, or turbulence, are eddies created by near-bottom shear flows, turbulent mixing near the surface, and vortex shedding from sensors, cables, and platforms. Laboratory simulation is accomplished through grid injection

of turbulence into recirculating flow facilities or by mechanical simulation methods. Their effects on sensor performance are more subtle and have been reported by Bivins and Appell [4] and Mero and Appell [5].

The use of the DT-NSRDC tow facility allows T&EL to assess performance of current sensors over a wide range of steady flow speeds and obtain a statistically significant number of data points to determine the quality of test data. The basin length of 274 m allows the acquisition of approximately 1 min of data at a constant carriage speed of 300 cm/s. The major limitation on the accuracy of speed data is the residual motion of the water in the tow basin. Carriage velocity is measured with respect to land to an accuracy of better than 0.1 cm/s; however, the residual water motion can be in the range of 0.15-1.0 cm/s. Shear currents are established during test runs and require considerable time to decay below 1 cm/s.

Two new ocean current sensors have been tested utilizing some of the techniques and simulation methods previously described. One was a Marsh McBirney, Inc. (MMI) Model 585 subsystem which utilizes the Model 555 spherical electromagnetic (EM) transducer. This transducer has been evaluated by T&EL at various times under different programs, and data have been accumulated on different serial number transducers. The second is a Neil Brown Instrument Systems Acoustic Current Meter (NBIS-ACM) which utilized an acoustic phase shift detection method for determining current velocity characteristics.

## II. SPHERICAL EM SENSOR

The MMI 4-in-diameter spherical EM transducers have displayed a characteristic steady flow calibration curve. The basic signature shows decreasing gain for flows ranging from 0 to approximately 20 cm/s; the trend then reverses and increases until a flow of approximately 120 cm/s is reached, and then the gain levels off. The resultant best fit straight line calibration equation for a single cardinal axis output results in *worst case errors* of  $\pm 1$  cm/s through a range of 0-250 cm/s. However, when calibrations are provided on all four cardinal axes and combined to compute a best fit straight line calibration equation for the average sensor performance (Fig. 1), a residual standard error (RSE)<sup>1</sup> on the order of 3 cm/s results over the range of 0-250 cm/s. The increase in residual error magnitude results from gain imbalance between the X and Y outputs and slight differences between the positive and negative outputs from each channel. Inspection of the output at the noncardinal angles and resolving the two output axes via the cosine rela-

Manuscript received November 1, 1977; revised July 12, 1978. This work was supported under a reimbursable agreement with the NOAA Data Buoy Office.

The author is with the Test and Evaluation Laboratory, NOAA/NOS, Rockville, MD 20852.

<sup>1</sup> RSE is the root mean square (rms) of all the residual calibration errors over the test range.

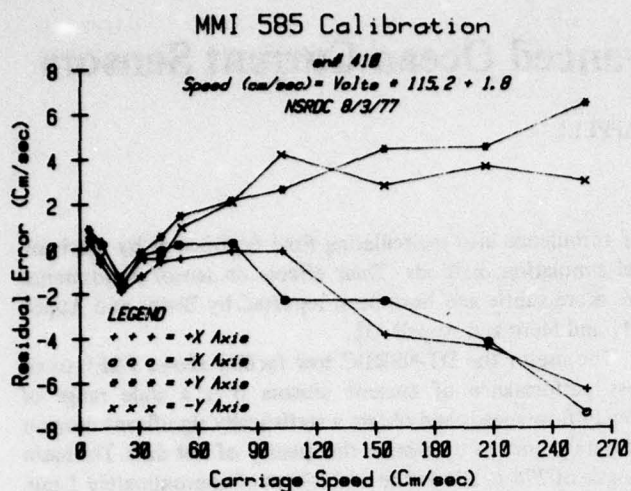

Fig. 1. Residual calibration errors are plotted as a function of tow carriage speed on the Marsh McBirney Model 585 EM current meter. Residual errors are derived from a first degree least square equation of actual flow speed as a function of current meter output voltage.

tionship indicates that no detectable additional errors are introduced due to noncosine response. The errors are introduced by the aforementioned cardinal axes gain imbalance. It is appropriate to mention at this point that the errors discussed are referenced to regression analysis equations that provide both slope and intercept. Utilizing the manufacturers' provided straight line gain with 0 intercept introduced additional error.

Analysis of the data during test conditions with varying vertical plane (tilt response) velocity components reveals a characteristic decrease in output with respect to a cosine function after the resultant vertical velocity angle exceeds  $\pm 10^\circ$ . An approximately 8-percent negative error from predicted cosine output was observed at  $\pm 30^\circ$  resultant vertical velocity angles. As the angle of the vertical velocity vector becomes steeper and flow becomes distorted as it passes over the Model 585 electronic housing, cosine response errors peak at -30 percent of the cosine value at a  $70^\circ$  angle. Steeper vertical velocity angles approaching the lower portion of the sphere from the mooring connection remain at approximately 8-percent negative error from true cosine response (Fig. 2). Output noise levels are variable and can be a function of the environment because the sensitivity of the electrodes is in the microvolt range. At the DT-NSRDC facility, we experience ambient noise levels of approximately 1 cm/s rms, which increases by a factor of 4 with flow velocities of 250 cm/s because of hydrodynamically induced noise. Zero offset is a problem with voltages usually present under initial conditions of approximately  $\pm 2$ - $\pm 4$  cm/s. This variation is not a long-term stability, but is rather the variability in the initial "no flow" output observed from different sensors and is an additional error source to the aforementioned calibration errors. The long-term fluctuations in this zero offset have not been investigated.

The dynamic response characteristics of the spherical EM sensors were investigated under conditions of simulated mooring heave motion in the presence of a net transport and under orbital water particle motion with net transport [4].

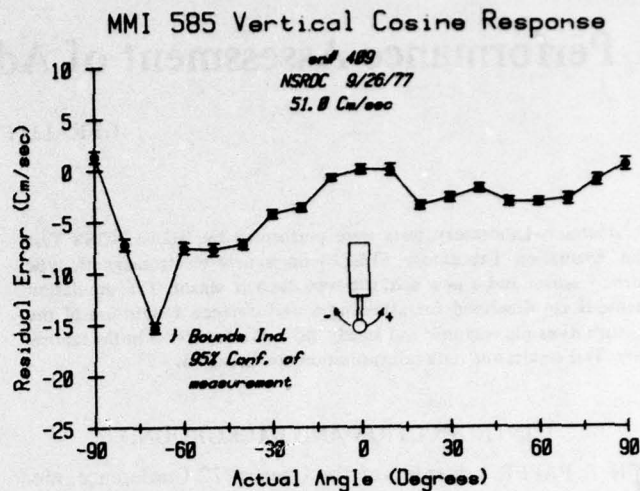

Fig. 2. Residual errors are plotted as a function of the resultant velocity vector angle in the vertical plane. Residual errors were derived as the difference between the current meter output and the cosine of the resultant velocity vector angle in the vertical plane referenced to the normal current meter attitude.

Tests with the vertical component considered as unwanted noise showed errors in averaging the net transport of less than 5 percent of reading under test conditions. The error was slightly negative as predicted by the steady flow vertical response tests [5]. The vertical velocity component in several test conditions had a peak magnitude of twice the transport velocity. Tests under orbital conditions were considerably more variable and not necessarily predictable from the steady flow vertical cosine. Low transport conditions (10 cm/s) showed that severe dynamics (orbital velocities of up to 78 cm/s) produced positive residual errors of from 35 to 85 percent of transport velocity depending on orbital velocity angle in relation to the transport vector. In general, under a less severe range of dynamics, the dynamic "noise" produced residual errors in the determination of transport velocity in the 5-percent range. Real-time analysis showed predictable phase and amplitude lag resulting from the sensor's 1-s time constant.

Where do we go from here in EM technology? In the near future, improvements can be expected in noise levels and zero output stability. MMI had redesigned the analog circuitry of the Model 555 sensor to improve its output characteristics. Transducer design is an ever changing art, and whether or not spherical, "open," [7] or other shapes prove to be superior in performance remains to be seen. The microscale turbulence effect on the 555 sensors has not been investigated, and there is a need for further correlation and prediction of dynamic performance through steady flow analysis methods. The long-term stability and reliability of these sensors should also be determined.

### III. ACOUSTIC PHASE SHIFT VELOCIMETER

The development of the acoustic phase shift velocimeter sensor [8] at NBIS was sponsored by the Office of Naval Research (ONR). NBIS is presently adapting this current measuring sensor into a subsystem for use in the NDBO Continental Shelf Buoy System. T&EL has tested several versions of the

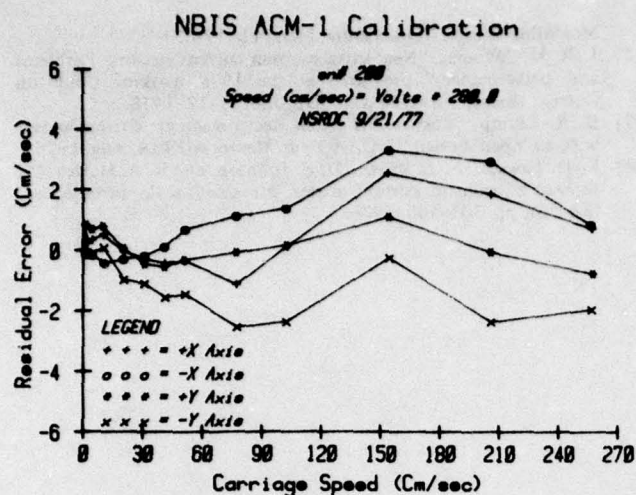

Fig. 3. Residual calibration errors are plotted as a function of tow carriage speed on the Neil Brown Instrument Systems acoustic current meter. Residual errors are derived from a straight line equation with zero intercept of actual flow speed as a function of current meter output voltage.

NBIS ACM-1, and each modification has significantly improved its performance. The ambient output signal noise at the DT-NSRDC facility is on the order of 0.1-cm/s rms equivalent flow velocity. Throughout the test range of velocities, the rms noise generally remained below 0.5 cm/s. Zero offset voltages in the latest version tested were below  $\pm 1$  cm/s. The high sensitivity of the sensor to flows below 1 cm/s allowed us to use the instrument to monitor the residual basin currents after each test run. The steady flow calibration has also improved with design modifications, and the most recent tests depict *worst case* residual velocity errors of approximately 1 cm/s over the range from 0 to 250 cm/s on a single cardinal axis. The combined calibration on all four cardinal axes utilizing a best straight line through zero (Fig. 3), as requested by the manufacturer, yielded RSE's of approximately 1 cm/s over the test range. The noncardinal angle calibrations indicated that resolving the output channels via a cosine relationship and computing the vector magnitudes yielded the proper output without additional errors.

The vertical response characteristics show that the output follows a cosine response within approximately 5 percent up to resultant vertical velocity angles of  $\pm 30^\circ$ . As the resultant vertical angle becomes steeper, the response falls off faster than the cosine relationship resulting in negative errors of 40 percent of the cosine value at a  $60^\circ$  resultant angle with respect to flow shedding from the reflecting mirror and negative errors of 20 percent of the cosine value with flow from the instrument housing. Increasing the angle from  $60^\circ$  to  $70^\circ$  returns the response to a close approximation of the cosine function (Fig. 4). Tests were performed under two simulated dynamic conditions of net transport in the presence of: 1) vertical oscillating flow and 2) horizontal oscillating flow. These tests were performed with a different apparatus setup than that used to produce orbital dynamics for the MMI sensors. In general, the vertical dynamics created negative errors in averaging the net transport as predicted from the

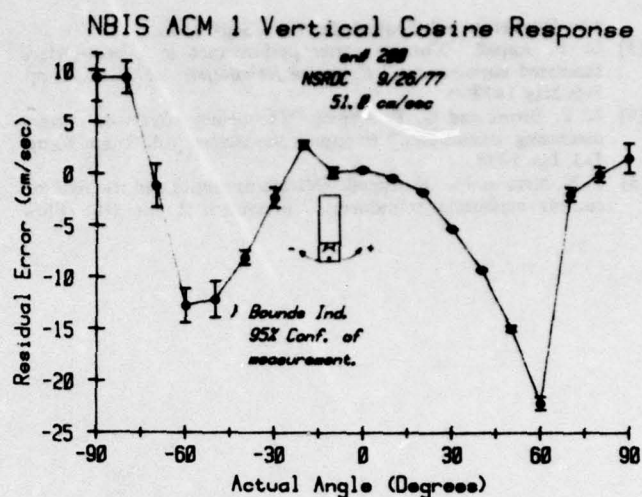

Fig. 4. Residual errors are plotted as a function of the resultant velocity vector angle in the vertical plane. Residual errors were derived as the difference between the current meter output and the cosine of the resultant velocity vector angle in the vertical plane referenced to the normal current meter attitude.

vertical cosine response. The data, however, were suspect because of flow distortion and blockage by the test holding fixture provided by the manufacturer, creating doubt as to the actual source of the errors. The horizontal dynamics tests also produced results that were questionable and inconclusive. These tests were performed on an earlier version of the ACM in which the calibration equation generated had considerable residual error uncertainty. Usage of that equation in the reduction of the dynamics data introduced errors resulting from steady flow calibration uncertainties. However, the general conclusion is that horizontal dynamics should average out to yield net transport to within better than 5 percent of true value. Further tests and data analysis should yield more conclusive results.

The NBIS sensor tested is designed for use in a moderate environment in which surface or mooring dynamics have been minimized. NBIS is presently working on a new transducer designed to improve vertical as well as horizontal response characteristics for use in a dynamic environment. The acoustic phase-shift-type sensor has not been evaluated to the extent that EM-type sensors have been over the past five years. There should be extensive investigation of the performance characteristic under all possible environmental conditions including effects of turbulence and other contaminants on the acoustic signal.

#### ACKNOWLEDGMENT

The author wishes to thank the following colleagues for their assistance in preparation of this paper: D. Crump and T. Mero for technical assistance and G. Russin for editorial comments.

#### REFERENCES

- [1] J. R. McCullough, "Problems in measuring currents near the ocean surface," presented at the MTS-IEEE Oceans '77 Conf., Los Angeles, CA, Oct. 1977.
- [2] A. N. Kalvaitis, "Current meter dynamic test apparatus," *Expo-*

- sure Newsletter*, vol. 3, no. 4, pp. 9-11, Sept. 1975.
- [3] G. F. Appell, "Current meter performance in a near-surface simulated environment," *Exposure Newsletter*, vol. 5, no. 2, pp. 5-9, May 1977.
- [4] L. E. Divins and G. F. Appell, "Turbulence effects on current measuring transducers," *Exposure Newsletter*, vol. 3, no. 6, pp. 1-5, Jan. 1976.
- [5] T. N. Mero and G. F. Appell, "Marine dynamics and its effect on current measuring transducers," presented at the NBS Flow Measuring Symp., Gaithersburg, MD, Feb. 1977.
- [6] J. R. McCullough, "Near-surface ocean current sensors: Problems and performance," presented at the 1978 Working Conf. on Current Measurement, Newark, DE, Jan. 11-13, 1978.
- [7] D. R. Crump, "Test results on an electromagnetic current sensor with an 'open' design," NOAA Tech. Memo. NOS 19, Aug. 1976.
- [8] K. D. Lawson, N. L. Brown, D. H. Johnson, and R. A. Matthey, "A three-axis acoustic current meter for small scale turbulence," *ISA ASI*, pp. 501-508, 1976.

## TABLE OF CONTENTS

Title Page

Standard Commercial Warranty

Limited Liability Statement

Table of Contents

List of Figures and Tables

1.0 General Information

1.1 Introduction

1.2 General Description

1.2.1 Card Rack

1.2.2 Reference Voltage Levels

1.2.3 Electrical Test Connector

1.2.4 Reference Direction Definitions and Serial Number

1.2.5 Mechanical Description

1.3 Specifications: ACM-1

2.0 Operation

2.1 Incoming Inspection

2.2 Disassembly Procedure

2.3 Loading/Unloading Cassette Tapes

2.3.1 Memodyne Recorder

2.3.2 Sea Data Recorder

2.4 Electrical Check

2.5 Assembly Procedure

2.6 Setting Clock and through Hatch Checks

2.7 Predeployment Check (Hatch Closed)

TABLE OF CONTENTS CONTINUED

- 3.0 Data Reduction
  - 3.1 Cassette Readers
  - 3.2 Tape Format
  - 3.3 Conversion of Recorded Data to Scientific Units
- 4.0 Functional and Circuit Description
  - 4.1 Velocity Function
    - 4.1.1 Velocity Transducer
    - 4.1.2 Oscillator Card
    - 4.1.3 Velocity Interface Cards
  - 4.2 Compass Function
    - 4.2.1 Compass
    - 4.2.2 Compass Electronics Card
  - 4.3 Signal Processing Function
    - 4.3.1 Signal Processor Card
    - 4.3.2 Analog-to-Digital Converter Card
  - 4.4 Power and Timing Function
    - 4.4.1 Battery Pack
    - 4.4.2 Power and Timing Card
  - 4.5 Time, Temperature and Accumulating Function
    - 4.5.1 Accumulator Card
    - 4.5.2 Thermistor
    - 4.5.3 Time and Temperature Card

## TABLE OF CONTENTS (CONTINUED)

- 4.6 Recording Function (Memodyne)
  - 4.6.1 Memodyne Recorder
  - 4.6.2 Memodyne Formatter (Type II) Card
- 4.7 Recording Function (Sea Data)
- 5.0 Adjustment, Calibration and Maintenance Procedures
  - 5.1 Setting Averaging Interval
  - 5.2 Setting Header Data Jumpers
  - 5.3 Electronics Adjustment and Calibration
    - 5.3.1 Oscillator Card Adjustment
    - 5.3.2 Velocity Interface Card Adjustment and Calibration
    - 5.3.3 Compass Electronics Adjustment
    - 5.3.4 Signal Processor Card Adjustment and Calibration
    - 5.3.5 Power and Timing Card Adjustment
    - 5.3.6 Analog to Digital Converter Card Adjustment and Calibration
    - 5.3.7 Memodyne Formatter (Type II) Card Adjustment
    - 5.3.8 Sea Data Recorder Adjustment
  - 5.4 Maintenance Procedures
- 6.0 Trouble-shooting
- 7.0 Schematics, Component Layouts
- 8.0 Parts List (Electrical)
- 9.0 Wire List

**TABLE OF CONTENTS (CONTINUED)**

**APPENDIX**

- A. Shipping Instructions**
- B. Theoretical Discussion of ACM-1**
- C. Memodyne Manual**
- D. Sea Data Manual**
- E. Mechanical Assembly Drawings & Parts**

## LIST OF FIGURES AND TABLES

Page #

Fig. 1.2.1-1	ACM-I CARD RACK (MEMODYNE RECORDER)
Fig. 1.2.1-2	ACM-I CARD RACK (SEA DATA RECORDER)
Table 1.2.3-1	TEST CONNECTOR J1 PIN FUNCTION AND SIGNAL DESCRIPTION
Fig. 1.2.5-1	ACOUSTIC CURRENT METER OUTLINE ACM-I
Fig. 1.2.5-2	ACM-I SENSOR AND ROD - CAGE DIMENSIONS
Fig. 1.2.5-3	ACM-I "O" RING SEALS
Table 2.0-1	SUMMARY OF ACM-I ELECTRICAL CHECKS
Table 2.4-1	ELECTRICAL CHECK SUMMARY
Fig. 2.5-1	DETAIL OF SENSOR END-CAP BOLT HARDWARE
Table 3.2-1	CASSETTE TAPE FORMAT (AVERAGING)
Fig. 3.2-1	ACM-I DATA FORMAT (AVERAGING)
Fig. 4.0-1	CURRENT METER FUNCTIONAL BLOCK DIAGRAM (MEMODYNE RECORDER OPTION)
Fig. 4.0-2	CURRENT METER FUNCTIONAL BLOCK DIAGRAM (SEA DATA RECORDER OPTION)
Fig. 4.1-1	VELOCITY FUNCTION BLOCK DIAGRAM
Fig. 4.1-2	EXAMPLE ORIENTATION OF CURRENT TO ACM-I VELOCITY TRANSDUCER
Fig. 4.1-3	ACOUSTIC CURRENT METER SENSOR GEOMETRY
Fig. 4.1.1-1	PIEZO-ELECTRIC TRANSDUCER EQUIVALENT CIRCUITS
Fig. 4.1.3-1	IDEALIZED WAVEFORMS FOR VELOCIMETER
Fig. 4.1.3-2	VELOCITY INTERFACE CARD PHASEMETER TIMING DIAGRAM

LIST OF FIGURES AND TABLES (CONT.)

Page #

- Fig. 4.2-1 COMPASS FUNCTION BLOCK DIAGRAM
- Fig. 4.2-2 EXAMPLE ORIENTATION OF LOCAL MAGNETIC FIELD TO ACM-I
- Fig. 4.2.1-1 CONCEPTUALIZED COMPASS WINDING (1 AXIS)
- Fig. 4.2.1-2 IDEALIZED WAVEFORMS FOR CONCEPTUALIZED COMPASS WINDING
- Fig. 4.3-1 SIGNAL PROCESSING FUNCTION BLOCK DIAGRAM
- Fig. 4.3-2 COMPASS AND CURRENT SENSOR COORDINATES
- Fig. 4.3.2-1 ANALOG-TO-DIGITAL CONVERTER CARD TIMING DIAGRAM
- Fig. 4.4-1 POWER AND TIMING FUNCTION BLOCK DIAGRAM
- Fig. 4.4.2-1 POWER AND TIMING CARD TIMING DIAGRAM
- Fig. 4.5-1 TIME, TEMPERATURE AND ACCUMULATING FUNCTION BLOCK DIAGRAM
- Fig. 4.5.1-1 ACCUMULATOR CARD TIMING DIAGRAM
- Fig. 4.5.2-1 ACM-1 THERMISTOR NETWORK
- Fig. 4.5.3-1 TIME AND TEMPERATURE CARD COMPASS TIMING DIAGRAM
- Fig. 4.5.3-2 TIME AND TEMPERATURE CARD TEMPERATURE TIMING DIAGRAM
- Fig. 4.6-1 RECORDING FUNCTION (MEMODYNE) BLOCK DIAGRAM
- Fig. 4.6.2-1 MEMODYNE FORMATTER (TYPE II) CARD TIMING DIAGRAM
- Fig. 5.3.1-1 OSCILLATOR CARD OSCILLOSCOPE WAVEFORMS

LIST OF FIGURES AND TABLES (CONT.)

Page #

- Fig. 5.3.2-1 VELOCITY CARD OSCILLOSCOPE WAVEFORMS
- Fig. 5.3.3-1 COMPASS ELECTRONICS CARD OSCILLOSCOPE  
WAVEFORMS
- Fig. 5.3.4-1 SIGNAL PROCESSOR CARD OSCILLOSCOPE  
WAVEFORMS

## INTRODUCTION

This manual has been designed to be a complete guide to the use and maintenance of the NEIL BROWN INSTRUMENT SYSTEMS ACOUSTIC CURRENT METER MODEL ACM-1. The ACM-1 is a precision self-contained current meter with recorder designed for longterm deployment applications. The ACM-1 can be provided either with a 3000 meter working depth rating or a 6000 meter working depth rating; and either with a Memodyne or a Sea Data cassette recorder. Each option is described fully in this manual.

Section 1.0 of this manual describes the ACM-1 in general and with detailed specifications.

Section 2.0 of this manual deals with the operation of the ACM-1. Operation includes all aspects of disassembly, assembly, set-up, and check-out. This section provides to the user the information required to deploy the instrument.

Section 3.0 of this manual deals with the various steps required to read the cassette tapes, correct the velocity data, and convert the data to scientific units.

Section 4.0 of this manual is a functional and circuit description of the ACM-1. This section is provided for the user who wishes to acquire a detailed understanding of the "HOW" of the ACM-1 in order to troubleshoot or adjust. This section is broken up into sub-sections of each functional block of the electronics. Within

these sub-sections, a function block diagram is included along with a detailed description of each card or sub-unit of the function.

Section 5.0 of this manual is the adjustment, calibration, and maintenance section. This section provides the step-by-step procedures for setting all adjustments or jumper options and procedures for changing the battery .

Section 6.0 of this manual is a brief check-list of troubleshooting procedures.

Sections 7.0 and 8.0 of this manual are the schematics, component layouts, pin connections and parts lists for the ACM-1. These sections can be referred to as required.

The appendices of this manual include the Memodyne or Sea Data recorder manuals; some theoretical discussion of acoustic current meters; and shipping instructions for the ACM-1.

## GENERAL DESCRIPTION

The NEIL BROWN INSTRUMENT SYSTEMS ACOUSTIC CURRENT METER MODEL ACM-1 is an internally powered true vector averaging water current meter with cassette recorder designed for unattended in-situ measurement of ocean currents and temperatures for periods in excess of one year. The ACM-1 velocity sensor utilizes an acoustic phase-shift technique capable of extremely high accuracy and resolution. This sensitivity is achieved in a sensor which is very simple and rugged and which has a theoretically predictable response that has been confirmed by tow tank testing. Because of variations of sound velocity with temperature, depth, salinity - corrections of recorded data must be performed in order to achieve the stated accuracy.

Along with relative water velocity, the package orientation in the horizontal must be determined. This is accomplished with a saturable core magnetometer compass. The compass output is inherently free of the dynamic response limitations of conventional compasses and is furthermore of exceptionally rugged design.

Velocity and compass information is generated by the sensors as analog levels proportional to the components of water current in the sensitive plane of the instrument (perpendicular to the axis of the pressure case) and to the local horizontal components of the magnetic field respectively. These analog levels are inputs to an analog processor which computes rectangular components of water velocity in earth coordinates. The rectangular earth components of velocity

(velocity North-South and velocity East-West) are converted to frequencies and counted for a pre-determined time interval to yield binary numbers proportional to water current. Note that a positive value for current in the North-South direction represents water movement toward the North and a positive value for current in the East-West direction represents water movement toward the East. This process is entirely continuous and uninterrupted, resulting in true vector averages completely representative of net transport.

Data as North-South and East-West averages along with ambient temperature, time (binary minutes), and status information are recorded after a predetermined interval. Data is recorded utilizing a Memodyne Model 201 transport (2.2 million bit capacity) or a Sea Data Model 610 transport (11 million bit capacity) depending on the option provided. Data cassettes are standard PHILIPS certified data type; capacity may be extended by 50% by using a 450 feet cassette rather than the 300 feet version.

Operating power for the current meter is provided by a lithium battery pack comprising 24 hermetically sealed "D" sized cells. This battery pack affords continuous operation of the meter for a minimum of 12 months. The battery has exceptional shelf-life allowing storage for more than 5 years without diminution of capacity. Operating endurance is entirely unaffected by deployment at temperatures approaching ice-point. Optional alkaline batteries are available.

While on deck an access hatch on the current meter upper end cap allows access to an electrical multipin connector providing

connection to the electronics for setting the internal clock and for diagnostic purposes. Also available is a purging tube running down the length of the housing which permits the interior of the housing to be purged with dry gas before closing the access hatch.

## CARD RACK

The current meter electronics is contained on 11 semicircular printed circuit cards for the Memodyne recorder option or 13 semicircular printed circuit cards in the case of the Sea Data recorder option. These cards are designed to fit efficiently into a 15.2 cm ID pressure housing. The electronics cards plug into a rack/backplane assembly which supports the necessary inter-connections while permitting easy interchange of cards. Electronic cards are numbered according to rack position with slot number one near the sensor end-cap. Each card in the rack contains a 35 pin connector. The card rack for the Memodyne recorder option is shown in Figure 1.2.1-1 and for the Sea Data recorder option is shown in Figure 1.2.1-2.

Fig. 1.2.1-1

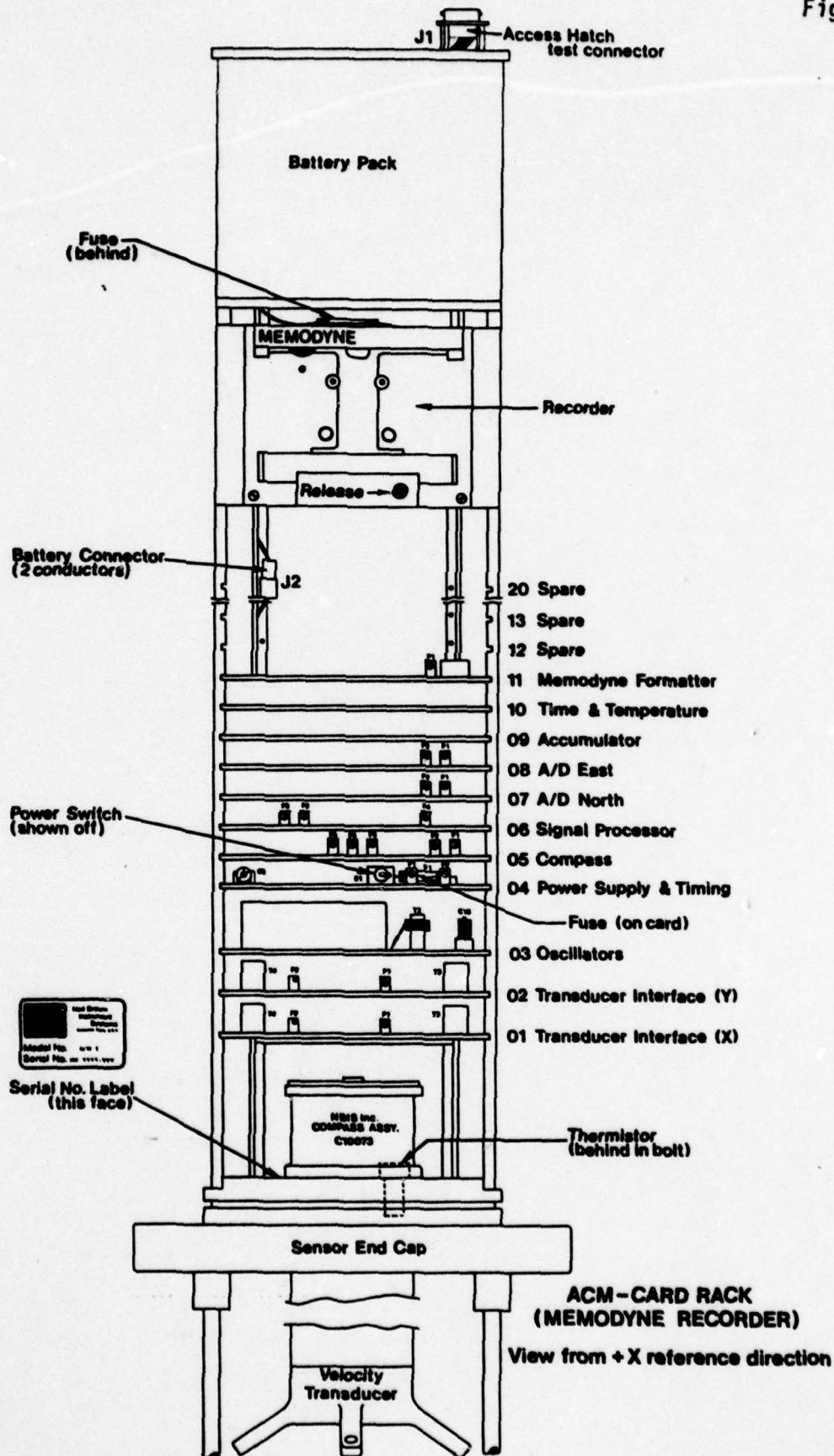
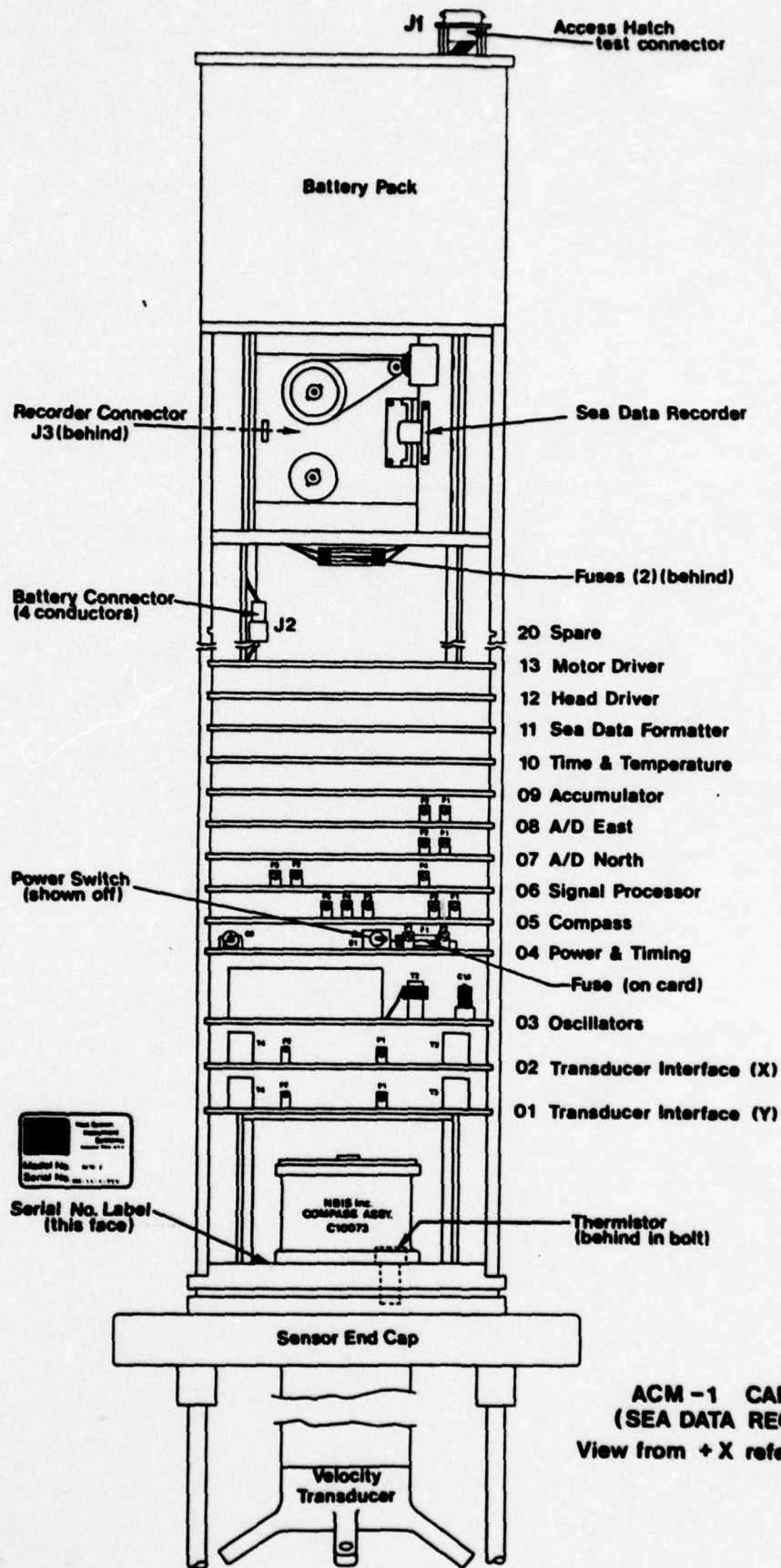

Fig. 1.2.1-2



## REFERENCE VOLTAGE LEVELS

Power is distributed to current meter circuits on the backplane. All power is provided by the lithium cells. The +8 volts nominal output of the battery package is linearly regulated to +3.00 volts and +6.00 volts. All logic circuitry (CMOS in every case) operates with  $V_{SS} = 0$  volt and  $V_{DD} = +6$  volts. All analog circuitry operates with analog common at +3 volts with  $V+ = +6$  volts and  $V- = 0$  volt. Motor power for the Memodyne recorder is derived by means of a DC/DC converter located on the Memodyne formatter card. The DC/DC converter operates only during the record cycle. Motor power in the case of the Sea Data units is provided by a split battery in which 6 of the 24 lithium cells are wired in series to produce a +16 volts nominal supply.

### ELECTRICAL TEST CONNECTOR

A keyed electrical test connector, referred to as J1, is mounted to the top of the electronics rack. This connector is accessible through the top end-cap hatch.

Connector type: Bendix PT02-14-18S

Mating Connector Type: Bendix PT08P-14-18P

This connector is used to set the internal clock and perform diagnostics as discussed elsewhere in this manual in conjunction with a TSDR-1 box (Time Set/Data Readout) or equivalent. The connector pins and signal definitions are as listed in Table 1.2.3-1.

Table 1.2.3-1

TEST CONNECTOR J1 PIN FUNCTION  
AND SIGNAL DESCRIPTION

PIN	FUNCTION	SIGNAL TYPE	DESCRIPTION
A	V <sub>x</sub> Output	Analog	Voltage proportional to the component of velocity in the +X direction. -2.0 to +2.0 volts for -300 to +300 cm/sec: (nominal)
B	V <sub>y</sub> Output	Analog	Same as V <sub>x</sub> output except for the +Y current direction.
C	H <sub>x</sub> Output	Analog	Compass output, representing the horizontal projection of the strength of local field in the +X direction. 6 volts per Oersted (typically +1 to -1 volts).
D	H <sub>y</sub> Output	Analog	Same as H <sub>x</sub> output except for the +Y compass direction.
E	Signal Common	Analog	Analog common, +3 volt (approx.) with reference to battery common.
F	Serial Data	Logic	Output - data as clocked to recorder.
G	Serial Clock	Logic	Output - shift register clock used to clock out data.
H	Time Reset	Logic	Input - resets binary minutes counter to zero. Logic 1 (+6 volts) resets counter.
J	Time Set	Logic	Input-fast clock used to set binary minutes counter to current time. Number of clocks equals time to be set.
K	Battery +8V	Power	Switched battery voltage.
L	Battery Common	Power	Logic common, 0 volts.
M	V <sub>N</sub> Output	Analog	DC Voltage (with AC signals present) proportional to the component of velocity in the North direction. -1.0 to +1.0 volt for -300 to +300 cm/sec (nominal)
N	V <sub>E</sub> Output	Analog	Same as V <sub>N</sub> except for the East direction.

of the major parts for the 3000 meter rated package with a Memodyne recorder option. Note that either of the recorder options may be used with either of the package types.

## REFERENCE DIRECTION DEFINITIONS AND SERIAL NUMBER

The ACM-1 current meter resolves average velocity components as velocity North-South and velocity East-West. This is accomplished regardless of the orientation of the meter in the horizontal. In order to check the operation of the meter, the reference directions must be known. The reference +X direction is in the direction the cards are removed which is the same as the direction the compass label points. With the housing on the instrument, the reference +X direction is identified by logo "NBIS ACM-1". The access latch is located on the housing  $112\frac{1}{2}^{\circ}$  counterclockwise (looking down) from the reference +X direction. Because of sign conventions, the +Y axis for velocity is  $90^{\circ}$  clockwise from +X axis (looking down) and the +Y axis for compass is  $90^{\circ}$  counterclockwise from the +X axis (looking down). Refer to Figure 4.3-2 for complete definition.

The logo "NBIS ACM-1" on the reference +X side of the housing is followed by the last seven digits of the unit serial number. The complete serial number is as follows: S/N 08-XXXX-YYY where XXXX is the job number under which the meter was built and YYY is the sequential serial number. This serial number also appears on a label on the inside of the sensor end-cap.

## MECHANICAL DESCRIPTION

The ACM-1 is housed in an aluminum case constructed of 6061-T6 alloy (3000 meter working depth) or 7075-T6 alloy (6000 meter working depth) depending on the option provided. The 3000 meter unit employs a welded top cap and thereby requires only a single two 'O' ring sealed closure. The 6000 meter unit utilizes two bolt-circle-retained double 'O' ring end caps. Both units are capable of withstanding through-housing tensile loads of 5000 Kg. The rod-cage assembly which carries the mooring tension and supports the acoustic mirror is fabricated from 6Al-4V titanium alloy. All external hardware is also titanium, resulting in high strength and freedom from corrosion. The hardware is electrically isolated from the aluminum housing to preclude the corrosive effects of galvanic coupling.

The housings are epoxy painted and unpainted surfaces are then hard coated, a sacrificial anode (zinc) completes the corrosion protection. Critical sensors are painted with a biological antifoulant (tri-butyl-tin-fluoride) to inhibit marine growth. Glassfilled fibre inserts are provided to prevent chafing of the eyes by shackles.

Figures 1.2.5-1 and 1.2.5-2 show the dimensional outline of the ACM-1. Figure 1.2.5-3 shows the location of the 'O' ring seals for the ACM-1. The mechanical assembly print is included in the Appendix.

Fig. 1.2.5-1

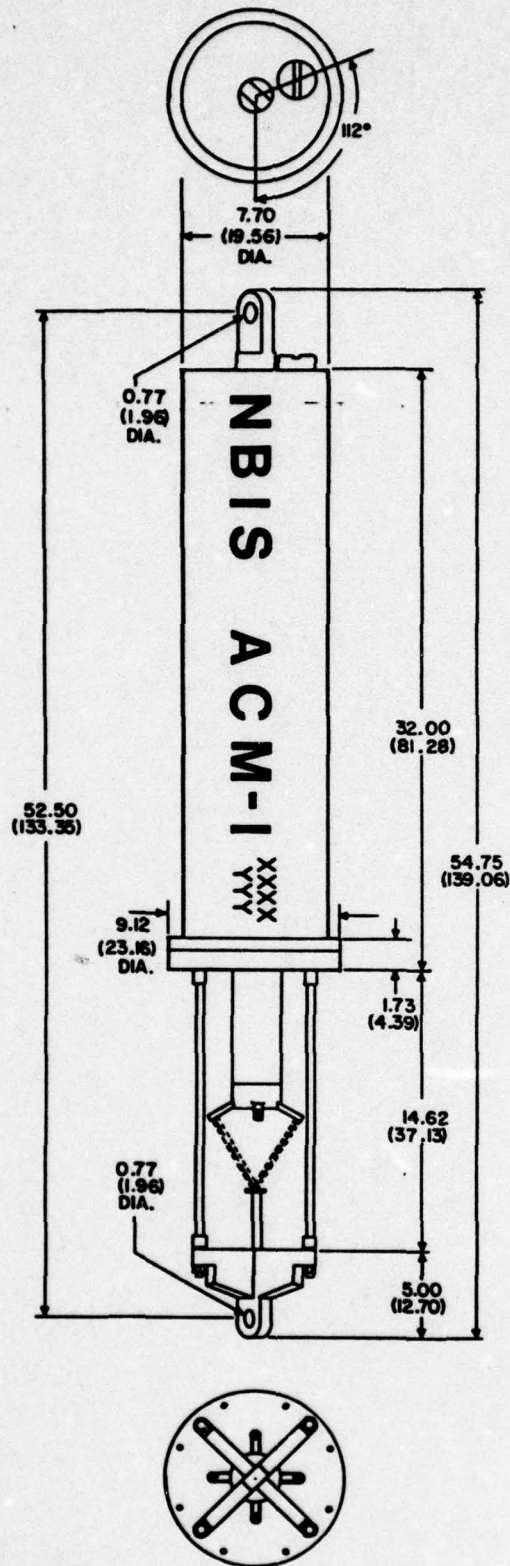

ACOUSTIC CURRENT METER OUTLINE ACM-I

Fig. 1.2.5-3

3000 METER  
UNIT ONLY

6000 METER  
UNIT ONLY

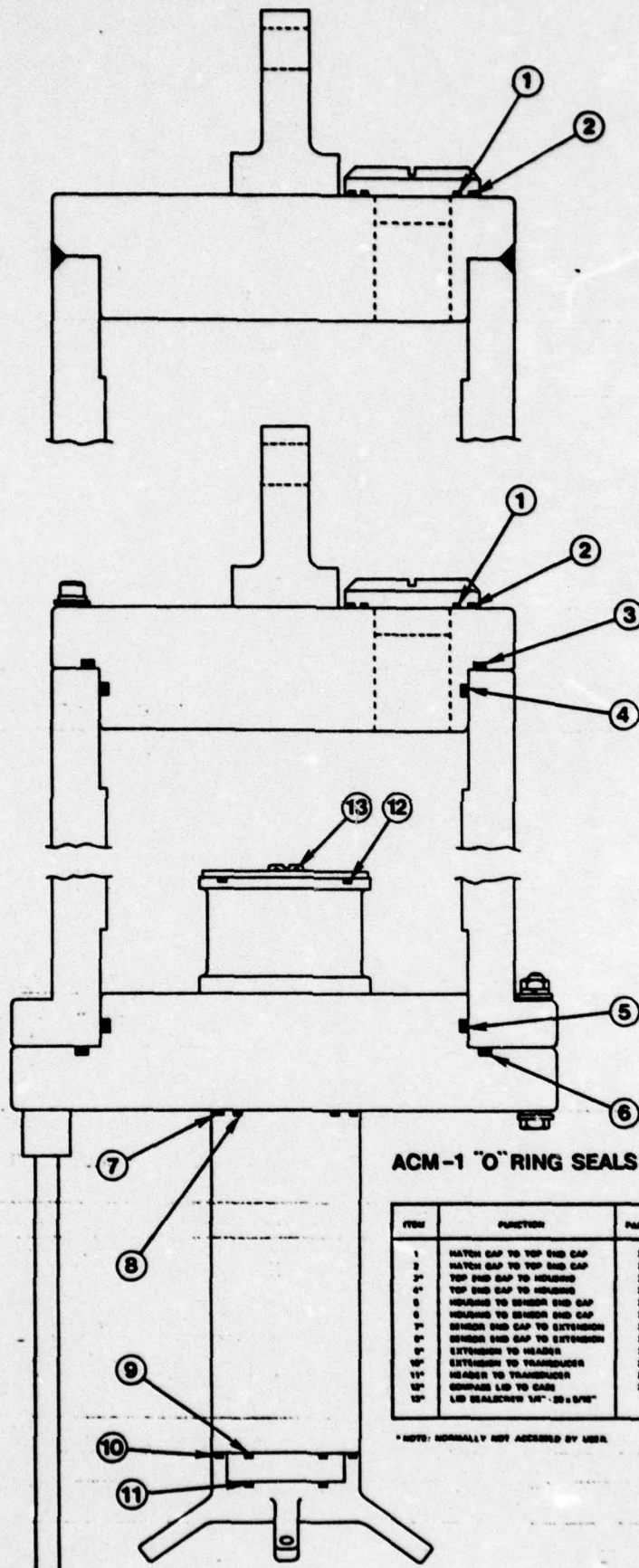

ACM-1 "O" RING SEALS

ITEM	FUNCTION	PART NO.	ID (INCHES)	W (INCHES)
1	MATCH CAP TO TOP END CAP	2-050	1.000	0.070
2	MATCH CAP TO TOP END CAP	2-050	1.250	0.070
3*	TOP END CAP TO HOUSING	2-100	0.250	0.100
4*	TOP END CAP TO HOUSING	2-200	0.250	0.100
5	HOUSING TO SENDER END CAP	2-200	0.250	0.100
6	HOUSING TO SENDER END CAP	2-200	0.400	0.100
7*	SENDER END CAP TO EXTENSION	2-050	0.100	0.070
8*	SENDER END CAP TO EXTENSION	2-050	1.000	0.070
9*	EXTENSION TO HEADER	2-050	1.170	0.070
10*	EXTENSION TO TRANSDUCER	2-050	0.100	0.070
11*	HEADER TO TRANSDUCER	2-050	1.170	0.070
12*	COMPASS LID TO CASE	2-050	0.070	0.070
13*	LID BEALSCREW 1/4" - 20 x 0.75"	-	-	-

\* NOTE: NORMALLY NOT ACCESSIBLE BY USER

## SPECIFICATIONS: ACM-1

## VELOCITY SENSOR-ACOUSTIC TRANSDUCER

Range:	0 to $\pm 300$ cm/sec (Nominal)
Accuracy:	$\pm 0.3$ cm/sec or $\pm 2\%$ whichever greater (After correction of sound velocity)
Linearity:	$\pm 1\%$ over range (best line through zero)
Cosine Response: (Horizontal)	$\pm 2\%$ (variation of vector magnitude through $360^\circ$ )
Cosine Response: (Vertical)	$\pm 2\%$ (deviation from cosine, $-30^\circ$ tilt)
Noise:	0.05 cm/sec rms in quiescent water 2.0 cm/sec at 300 cm/sec
Response Time:	0.2 seconds

## DIRECTION SENSOR-MAGNETOMETER COMPASS

Range:	0 to $360^\circ$
Accuracy:	$\pm 2^\circ$
Response Time:	0.2 seconds
Tilt Limit:	$\pm 30^\circ$

## TEMPERATURE SENSOR-THERMISTOR

Range:	$-2.4^\circ\text{C}$ to $35.85^\circ\text{C}$
Accuracy:	$\pm 0.5^\circ\text{C}$
Resolution:	$0.15^\circ\text{C}$ (8 bits)
Response Time:	5 minutes

## CURRENT MEASUREMENT OVERALL

Accuracy (Vector Magnitude):	$\pm 0.5$ cm/sec or 3% whichever greater
Accuracy (Vector Direction):	$\pm 5^\circ$ for magnitude greater than 10cm/sec

**DATA RECORDER**

**Type:** Memodyne Model 201 Cassette Recorder  
 or  
 Sea Data Model 610 Cassette Recorder

**Format:** Inter-record gap  
 Header (8 bits)  
 10 velocity pairs (N-S, E-W components)  
 (2x12x10 bits)  
 Temperature (8 bits)  
 Instrument Reference axis heading (8 bits)  
 Status (4 bits)  
 Time (20 bits)

**Cassette Tape:** Standard Philips certified data cassette  
 (.15 inch 0.7 mil)  
 Magnetic tape 300 or 450 feet

**Capacity:** Memodyne = >70,000/>105,000 averages  
 (300/450 feet) Sea Data = >350,000/>525,000 averages

**TIMING AND CLOCK**

**Time:** Binary Minutes (settable via access hatch connector)

**Accuracy:** 0.002% Crystal Controlled

**Averaging Interval:** Integer minutes 1 to 15

**Recording Interval:** Every 10 averaging intervals

**Sampling Time:** Continuous

**BATTERY**

**Type:** Lithium battery pack  
 (24 hermetically sealed "D" sized cells)

**Shelf Life:** >5 years

**Operating Life:** >12 months (continuous)

**Capacity:** 640 watt-hours

**Power Consumption:** 0.05 watt (average)

**ENVIRONMENTAL**

Operating Temperature:  $-2^{\circ}\text{C}$  to  $+35^{\circ}\text{C}$  (for stated accuracy)  
Storage Temperature:  $-35^{\circ}\text{C}$  to  $+70^{\circ}\text{C}$   
Rated Depth: 3000 meter  
or  
6000 meter

**MECHANICAL**

Weight: 34 Kg (In Air)  
13 Kg (In Water)  
Dimensions: 49.12 inches (124.0 cm) overall length  
9.25 inches (23.5 cm) maximum diameter  
Materials: Aluminum housing (6061 alloy for  
3000 meter option or 7075 alloy  
for 6000 meter option), titanium  
rod assembly.  
Surface Protection: 1) Dissimilar Metals electrically isolated  
2) Aluminum parts hard-coat anodised  
and epoxy painted  
3) Zinc anode  
4) Anti-foulant painted (tri-butyl-  
tin-fluoride)

**DEPLOYMENT**

Endurance: >1 year  
Mooring: Inline, maximum tension 5000 Kg.

**SHIPPING CONTAINER**

Type: Rugged wooden reuseable shipping  
case suitable for shipment or ship-  
board use.  
Weight: 55 Kg with current meter  
Dimensions 13 inches x  $14\frac{1}{2}$  inches x 62 inches  
(33 cm x 37 cm x 158 cm)

**ACCESSORIES (consult factory for details)**

1. Time Set/Data Readout Box
2. Tape Readers
3. Spare Parts

**OPTIONS (consult factory for details)**

1. Burst sampling
2. Different cassette formats
3. Expanded temperature resolution
4. Additional sensors
5. Alkaline battery packs

**OPERATION**

Basically the ACM-1 is a simple instrument to operate - the steps are as follows:

1. Open access hatch
2. Disassemble sensor end-cap from housing
3. Insert cassette tape
4. Turn power switch to "on"
5. Assemble sensor end-cap to housing
6. Set clock through access hatch and check data by means of a Time Set/Data Readout box or equivalent.
7. Purge housing with dry gas and close access hatch
8. Deploy the instrument

The retrieval sequence is also basically simple - the steps are as follows:

1. Open access hatch
2. Disassemble sensor end-cap from housing
3. Turn power switch to "off"
4. Remove cassette
5. Read cassette to retrieve data.

Detailed instructions for disassembly; loading/unloading cassette tapes; assembly; and setting the clock are included in the following sub-sections. Section 3.0 deals entirely with reading of the cassette tapes and reducing the data.

The best check of the ACM-1 is to record a cassette tape.

The ideal condition to record a cassette tape is with the ACM-1 transducer upright in a bucket of water in a "cold room". In order to keep condensation off the electronics, this should be done with the unit sealed in its housing as for a deployment. After several days (or hours), remove the ACM-1 from the "cold room" and disassemble the electronics from the housing (allow time for the electronics to reach room temperature before opening). The cassette tape is then removed and read to verify performance. Note that if the ACM-1 velocity transducers are left in air, the velocity data will not be predictable and may be erratic (the phase-locked loop oscillators are without inputs when acoustic signals are not being received through the water).

In order to insure that the ACM-1 is working and is properly aligned, four levels of electrical checks have been defined and are summarized in Table 2.0-1. The application of the various checks is dependent on the user's time schedule and manpower. The user may choose to turn power "on"; perform electrical checks; assemble the housing; set the time; and close the access hatch all at the maintenance depot or all shipboard. The operating life and cassette capacity allow the user the choice of turning on the ACM-1 months before the actual deployment.

The various mechanical checks of integrity, proper seating of 'O-rings', etc. must be performed during all phases of operation.

**INCOMING INSPECTION**

1. Check the shipping container for external damage - notify the shipper if damage is found.
2. Unpack the ACM-1. Unless otherwise instructed, the ACM-1 is delivered in the "off" condition with the following:
  - a. Fully calibrated for nominal full-scale of 300 cm/sec
  - b. Averaging interval of one minute
  - c. Header word set-up as - indicated on the "Final Inspection Certificate"
  - d. Fully pressure and temperature checked.

The user is referred to Section 5.0 of this manual for directions for changing items b) and c) above.

3. Visually inspect the ACM-1 for damage.
4. Read and understand the operating sections (1.0 and 2.0) of this manual before proceeding with any further steps.
5. Open access hatch and disassemble sensor end-cap from housing.  
(Section 2.2)
6. Visually inspect electronics for damage.
7. Perform electrical checks or through access hatch checks as desired (sections 2.4 and 2.6).

MANUAL SECTION	CHECK TYPE	DESCRIPTION	WHEN REQUIRED	LOCATION
5.3	Adjustment & Calibration	Adjustments for each ACM-1 card are checked and corrections made as required. Unit is checked to be in calibration.	Before unit is delivered or After long term deployment and before next deployment	Neil Brown Instrument System or Depot
2.4	Electrical Check (out of housing)	No adjustments made. Signals are jumpered and responses are measured to check compliance with known outputs. Cassette tape is generated and read	Incoming inspection and Before deployment	Depot or Shipboard
2.6	Through Hatch Checks	Time is set and data read out through hatch while sensor is in water bucket.	Before deployment	Depot or Shipboard
2.7	Acoustic Check (Hatch Closed)	Pocket radio used to verify acoustic transmissions	Immediately before deployment	Shipboard

TABLE 2.0-1 SUMMARY OF ACM-1 ELECTRICAL CHECKS

## DISASSEMBLY PROCEDURE

WARNING: If the ACM-1 has been used at high pressure (i.e. a deep deployment), there is the possibility that a leak occurred and the housing contains high pressure air. An electrical check of the acoustic signal with a AM radio (see Section 2.7) will indicate whether the unit is functioning. If it is not functioning after a deployment, observe extreme caution in opening the housing. Open access hatch (if possible) or sensor end-cap slowly to allow any high pressure air to escape.

OPENING ACCESS HATCH:

1. Turn access hatch cap counterclockwise to open (about four revolutions). Use a plastic or fiberglass straight edge in the hatch groove to turn the cap. DO NOT USE METAL TOOLS in order to avoid chipping the paint.

OPENING SENSOR END-CAP:

1. Alternately loosen the eight titanium bolts around the sensor end-cap. The nut uses a 7/16" wrench and the screw a 3/8" wrench.
2. Firmly start the sensor end-cap out of the housing by pulling on the rod-cage assembly.
3. Remove bolts.
4. Remove housing from sensor end-cap assembly.

### LOADING/UNLOADING CASSETTE TAPES

An extremely important factor in the reliability of the cassette recording is the cassette itself. Only a properly certified data tape cassette should be used. 300 or 450 feet cassettes may be used. The cassette, if not new, should be completely erased (either AC or DC erasure is ok). The mechanical tolerances of the cassette cartridge and the tape tension are also significant factors in the reliability of operation. Tape handling is also important. Cassettes should be kept in their containers to prevent dirt and dust from collecting on their surfaces. The containers also lock the spools in one position to maintain tape tension. Cassettes should not be used if the tape is wrinkled or scratched. Avoid touching the tape surface. The loading/unloading of cassette tapes for the two type of recorders provided with the ACM-1 are described in the following sub-sections. Refer to the Memodyne or Sea Data manuals for more details.

## MEMODYNE RECORDER

LOADING CASSETTE: Prior to loading, the cassette should be inspected to assure that the tape is clean and that the spools are tight, eliminating slack tape. The tape should be manually advanced past the clear leader (with the supply side spool to the right). The cassette should be labeled (if desired) with time, date and comments.

1. Depress the release button (PUSH) to release the head (unless already released).
2. Insert bottom of the cassette behind the retainer and against the bottom spring.
3. Push the cassette down and back, allowing the hubs to protrude through the spools. Continue to push the cassette back until both hubs are in position.
4. Depress the head assembly to lock the head and capstan into position.

When recording begins; inspect the operation to determine that the takeup hub rotates, assuring proper operation. If the cassette is improperly mounted, the takeup hub may bind. This condition can cause excess tape to pop out of the cassette and wind around the capstan, damaging the tape.

UNLOADING CASSETTE:

1. Depress the release button (PUSH) to release the head.
2. Pull the top of the cassette down and out until clear of head. Remove the cassette free of the recorder.
3. Label the cassette (if desired) with time, date, comments.
4. Return cassette to protective container.

## SEA DATA RECORDER

**LOADING CASSETTE:** Prior to loading, the cassette should be inspected to assure that the tape is clean and that the spools are tight. The tape should be manually advanced past the clear leader (with the supply side spool down). Slack the tape slightly to allow the free hub movement. The cassette should be labeled (if desired) with time, date and comments.

1. Remove the transport cover by removing the 4-40x3/8" screw and peeling back the cover edge.
2. Open the head carrier handle, make sure its all the way open. Remove head cover (if installed).
3. Orient the cassette with the full tape spool over the feed clutch hub and insert from front of the transport, lowering the back of the cassette under the spring.
4. Checking that the cassette sprockets properly engage the transport hubs without binding, lower the front of the cassette past the head protection pins. TAKE CARE THAT THE TAPE GOES BETWEEN THE CAPSTAN AND PINCH ROLLER.
5. Pushing the cassette to the rear of the transport, settle it over the front guide pins and catch the internal ridge in the cassette under the guide pin lip (not all cassettes have ridges).
6. Close the handle, checking head clearance in the cassette. Check the cassette sprockets to insure that they are free on the clutch hubs. Wiggle the cassette to check seating against the front guide pins.

## 2.3.2

7. Reinstall the transport cover, check for proper fit on all fasteners.

When recording begins, inspect the operation to determine proper tape movement.

### UNLOADING CASSETTE:

1. Remove the transport cover by removing the 4-40 x 3/8" screw and peeling back the cover edge.
2. Open the head carrier handle.
3. Remove the cassette free of head and guide pins. Remove free of spring.
4. Label the cassette (if desired) with time, date, comments.
5. Return cassette to protective container.

## ELECTRICAL CHECK

The following operational checks are designed to verify the proper and calibrated operation of the current meter. (See Section 5.3 for adjustment and calibration procedures.) These checks are performed with the ACM-1 out of its housing; the checks are made in air and in a small tank (1 meter square) of still water. Results can be verified both as analog measurements and digital results as read from cassette tape or through a TSDR box. These checks are summarized in Table 2.4-1.

- Equipment required:
1. DC Voltmeter/Ammeter
  2. Oscilloscope
  3. Card Extender
  4. Frequency Counter
  5. Cassette Reader
  6. Two 4.7M ohm resistors (5%)  
Two 100K ohm resistors (5%)
  7. Compass

**WARNING:** Always remove or insert cards with the power turned "off". Follow proper handling procedures for CMOS integrated circuits.

1. Battery Voltage. With a DC voltmeter, measure between the BATTERY + and 0 VREG on the power and timing card (0430 to 0428).

BATTERY + = 8.4 VDC (typical)  
(Recorder Off)

BATTERY + = 8.4 VDC (typical)  
(Sea Data On)

BATTERY + = 7.3 VDC (typical)  
(Memodyne On)

**Note:** these voltages apply to the lithium battery package only.

2. Supply Current. With the power switch S1 "off" (power and timing card 04) connect an ammeter across the switch (0432 to 0430) and measure the drain from the +8 battery.

$$I_{\text{SUPPLY}} = 5.5 \text{ ma (typical)}$$

(Recorder Off)

$$I_{\text{SUPPLY}} = 6.4 \text{ ma (typical)}$$

(Sea Data On)

$$I_{\text{SUPPLY}} = 270 \text{ ma (typical)}$$

(Memodyne On)

3. Supply Voltages. S1 "on". Voltmeter return on 0435, connect DC voltmeter to V+ (0429).

$$V+ = +3.000 \text{ VDC} \pm 10 \text{ mV}$$

Connect voltmeter to V - (0428)

$$V- = -3.000 \text{ VDC} \pm 10 \text{ mV}$$

4. Oscillator Lock. Voltmeter return on 0435 and meter + to oscillator card 03 test point 4.

$$V_{\text{LOCK}} = 0 \pm 0.5 \text{ VDC}$$

5. Oscillator Mixer. Oscilloscope return on 0435 and 10X probe on test point 2; verify distorted sine wave of 34 Hz (see Figure 5.3.1-1).

$$\text{TP2} = 80 \text{ mVp-p} \pm 20 \text{ mVp-p}$$

6. Interface Amplitude. Place the velocity transducer as deep as possible in a 1 meter cube of water. With a 10X probe of an oscilloscope, measure between TP3 and analog ground (pin 35) on both the X interface (card 01) and Y interface (card 02). Measure TP4 on both cards.

$$\text{TP3 (4)} = 2\text{Vp-p} \pm 0.5\text{Vp-p}$$

7. Interface Zero. With the transducer in still water, measure with a DC voltmeter  $V_x$  (0110) and  $V_y$  (0210) with the meter return on pin 35.

These signals are also available through the test connector J1. Verify the digital data on tape and/or through the TSDR box.

$$V_x (V_y) = 0 \pm 4 \text{ mVDC}$$

$$N_{V_N} (N_{V_E}) = 800_{\text{HEX}} \pm 4 \text{ counts}$$

8. Interface Scale. With the transducer out of water or the oscillator card removed, attach +6 volts DC (V+, pin 34) through 100K to TP3 and 0 volts DC (V-, pin 31) through 100K to TP4. This set-up should be on the X interface (card 01) and then the Y interface (card 02). Momentarily touch the 34 Hz reference signal (0404) through a 4.7M ohm resistor to TP1 on the corresponding interface card. Measure with a DC voltmeter between the signal output (pin 10) and analog common (pin 35).

$$V_x (V_y) = +2.000 \pm 10 \text{ mVDC}$$

Check the negative fullscale by momentarily touching the 34 Hz reference through a 4.7M ohm resistor to TP2.

$$V_x (V_y) = -2.000 \pm 10 \text{ mVDC}$$

Allow both of these set-ups to remain long enough for several averaging periods and verify the digital data on tape and/or through the TSDR box. Note that in order that  $V_x = V_N$  and  $V_y = V_E$ , align the reference meter direction to magnetic North. Removing the compass electronics card will also force the signal processor to approximately a North heading. If this alignment is not done, the digital results can only be compared after resolution of the vectors.

$$N_{V_N} (N_{V_E}) = \text{FFF}_{\text{HEX}} \text{ (typical for + fullscale)}$$

$$N_{V_E} (N_{V_N}) = \text{000}_{\text{HEX}} \text{ (typical for - fullscale)}$$

9. Interface Half Scale. Attach +6 volts DC (V+, pin 34) through a 100K ohm resistor to TP4 and connect the 34 Hz reference signal through a 4.7M ohm resistor to TP1. The transducer should be out of the water or the oscillator card removed. Measure the output signal (pin 10). Do this for both X and Y interface cards.

$$V_x (V_y) = +1.00 \text{ VDC} \pm .02 \text{ VDC}$$

Attach the +6 volts DC (V+, pin 34) through 100K to TP3 and connect the 34 Hz reference signal through 4.7M ohm to TP2. Measure the output signal (pin 10).

$$V_x (V_y) = -1.00 \text{ VDC} \pm .02 \text{ VDC}$$

Note that these are also available through test connector J1. Allow both of these set-ups to remain long enough for several averaging periods and verify the digital data on tape and/or through the TSDR box. Align the meter to North or resolve the vectors to check results.

$$N_{V_N} (N_{V_E}) = 000_{\text{HEX}} \text{ (typical for + half scale)}$$

$$N_{V_N} (N_{V_E}) = 400_{\text{HEX}} \text{ (typical for - half scale)}$$

10. Compass. With the compass tilted less than  $30^\circ$ , measure  $H_x$  (pin 22 to return pin 23) and  $H_y$  (pin 06 to return 05) on the compass electronics (card 05). These signals are also available on test connector J1. Measure the heading of the compass by placing a needle type compass as close to the NBIS compass as possible. Note that the NBIS label on the compass is heading direction.

$$H_x = \sim \cos (\text{HEADING})$$

$$H_y = \sim \sin (\text{HEADING})$$

$$\text{HEADING} = \tan^{-1} \left( \frac{H_y}{H_x} \right)$$

Note that the  $H_x$  and  $H_y$  are nominally 1.0 volt; the actual magnitude of  $H_x$  and  $H_y$  are only important as the arctangent of their ratio.

11. Compass Counts. For the heading set up as above, measure the compass counts frequency at pin 13 to pin 35 on the time-temperature card (slot 10)

$$\text{FREQUENCY} = 45.511 \text{ HEADING}$$

where HEADING is in degrees and frequency in hertz. Some headings and frequencies are tabulated below.

HEADING (DEG)	FREQUENCY (Hz)
0 (N)	0
45	2048
90 (E)	4096
135	6144
180 (S)	8192
225	10240
270 (W)	12288
315	14336

12. Temperature. Measure the temperature count frequency on the time-temperature card (slot 10) on pins 27 to return 35.

$$\text{FREQUENCY} = 34.133 (T + 2.4)/38.25$$

where T is the temperature in degrees celcius and frequency is in hertz.

Some temperatures are tabulated on the following page.

TEMPERATURE (°C)	FREQUENCY (Hz)
0	2.1
5	6.6
10	11.1
15	15.5
20	20.0
25	24.5
30	28.9
35	33.4

13. Time. Set the time clock and read-back the results with a TSDR box or from the cassette tape on a tape reader.

14. Cassette Recorder. With the various set-ups for interface half-scale, fullscale, and zero, record data and verify tape movement every  $10N$  minutes (where  $N$  is wired on the card connectors to be 1 to 15, normally 1). Note that the data on tape is resolved  $V_N$  and  $V_E$ ; set the compass to a known heading or remove the compass card which forces the compass inputs to the signal processor card to approximately a North setting. With a North heading,  $V_x$  will equal  $V_N$  and  $V_y$  will equal  $V_E$ . The various digital results are tabulated in Table 2.4-1.

TABLE 2.4-1 ELECTRICAL CHECK SUMMARY

CHECK	EQUIPMENT	SIGNAL	RETURN	ANALOG RESULT	DIGITAL RESULT	CONDITIONS
1. Battery Voltage	DC Voltmeter	0430	0428	8.4 VDC (typical)	--	Recorder off/Sea Data on
	DC Voltmeter	0430	0428	7.3 VDC (typical)	--	Memodyne on
2. Supply Current	DC Ammeter	0430	0432	5.5 ma (typical)	--	Recorder off & S1 off
	DC Ammeter	0430	0432	6.4 ma (typical)	--	Sea Data on & S1 off
	DC Ammeter	0430	0432	270 ma (typical)	--	Memodyne on & S1 off
3. Supply Voltages	DC Voltmeter	0429	0435	+3.000VDC±10mVDC	--	
	DC Voltmeter	0428	0435	-3.000VDC±10mVDC	--	
4. Oscillator Lock	DC Voltmeter	03-TP4	0435	0 ± 0.5 VDC	--	
5. Oscillator Mixer	Oscilloscope	03-TP2	0435	34Hz, 80mVp-p±20mVp-p	--	
6. Interface Amplitude	Oscilloscope	01-TP3	0135	34Hz, 2Vp-p±.5Vp-p	--	Transducer in Water
	Oscilloscope	01-TP4	0135	34Hz, 2Vp-p±.5Vp-p	--	Transducer in Water
	Oscilloscope	02-TP3	0235	34Hz, 2Vp-p±.5Vp-p	--	Transducer in Water
	Oscilloscope	02-TP4	0235	34Hz, 2Vp-p±.5Vp-p	--	Transducer in Water
7. Interface Zero	DC Voltmeter	0110	0135	0 ± 4mVDC	800 <sub>HEX</sub> ± 4	
	DC Voltmeter	0210	0235	0 ± 4mVDC	800 <sub>HEX</sub> ± 4	
8. Interface Scale	DC Voltmeter	0110	0135	+2.000VDC±10mVDC	FFF <sub>HEX</sub> (Note 1)	Out of Water; V+ to 100K to TP3; V- 100K to TP4 (Note 2)
	DC Voltmeter	0110	0135	-2.000VDC±10mVDC	000 <sub>HEX</sub> (Note 1)	Out of Water; V+ to 100K to TP3; V- 100K to TP4 (Note 3)

TABLE 2.4-1 ELECTRICAL CHECK SUMMARY

(Continued)

CHECK	EQUIPMENT	SIGNAL	RETURN	ANALOG RESULT	DIGITAL RESULT	CONDITIONS
9. Interface Half-Scale	DC Voltmeter	0210	0235	+2.000VDC±10mVDC	FFF <sub>HEX</sub> (Note 1)	Out of Water; V+ to 100K to TP3; V- to 100K to TP4 (Note 2)
	DC Voltmeter	0210	0235	-2.000VDC±10mVDC	000 <sub>HEX</sub> (Note 1)	Out of Water; V+ to 100K to TP3; V- to 100K to TP4 (Note 3)
	DC Voltmeter	0110	0135	+1.00VDC±.02VDC	C00 <sub>HEX</sub> (Note 1)	Out of Water; V+ to 100K to TP4; 0404 to 4.7M to TP1
	DC Voltmeter	0110	0135	-1.00VDC±.02VDC	400 <sub>HEX</sub> (Note 1)	Out of Water; V+ to 100K to TP3; 0404 to 4.7M to TP2
	DC Voltmeter	0210	0235	+1.00VDC±.02VDC	C00 <sub>HEX</sub> (Note 1)	Out of Water; V+ to 100K to TP4; 0404 to 4.7M to TP1
	DC Voltmeter	0210	0235	-1.00VDC±.02VDC	400 <sub>HEX</sub> (Note 1)	Out of Water; V+ to 100K to TP3; 0404 to 4.7M to TP2
10. Compass	DC Voltmeter	0522	0523	~COS(HEADING)VDC	N <sub>C</sub> =HEADING/1.5	Note 4; COMPASS TILT < 30°
11. Compass Counts	DC Voltmeter	0506	0505	~SIN(HEADING)VDC	N <sub>C</sub> =HEADING/1.5	Note 4; COMPASS TILT < 30°
	Frequency Meter	1013	1035	45.511(HEADING)Hz	N <sub>C</sub> =HEADING/1.5	COMPASS TILT < 30°
12. Temperature	Frequency Meter	1027	1035	34.133(T+2.4)/38.25Hz	N <sub>T</sub> =(T+2.4)55/3825	T = end-cap temperature (°C)
13. TIME	TSDR Box	J1	J1	--	Correct Time	See detailed Instructions
14. Cassette Recorder	Cassette Recorder	--	--	--	Correct Data	See detailed Instructions

NOTE 1: Typical results for North heading; resolve vectors for other headings.

NOTE 2: Momentarily touch 0404 to 4.7M ohm to TP1

NOTE 3: Momentarily touch 0404 to 4.7M ohm to TP2

NOTE 4: Amplitude nominally ±1.0 volts; actual values important only as the function  $\tan^{-1}(Hy/Hx)$ .

## ASSEMBLY PROCEDURE

CLOSING SENSOR END-CAP:

1. If the unit is to operate -
  - a. Load cassette tape
  - b. Check that desired averaging interval is wired on the rack backplane (1 to 15 minutes)
  - c. Turn power switch to "ON" (card 04)
  - d. Perform electrical checks (see Section 2.4)
2. Be sure all "O" rings are clean and slightly greased (Dow Corning No. 4 Compound Silicone Grease or equivalent). Check that all mating surfaces are clean and free of scratches.
3. Insert sensor end-cap assembly into housing. Be sure the electrical connector lines up with the access hatch. Gently force end-cap and housing together checking that "O" rings do not pinch.
4. Insert titanium bolt hardware into the eight bolt holes. Insert hexcap screw, flatwasher, and nylon shouldered washer from sensor end-cap side and attach with a nylon shouldered washer, flatwasher, lockwasher, and hex nut on housing side.
5. Alternately tighten the eight titanium bolts. The nut uses a 7/16" wrench and the screw a 3/8" wrench. Tighten to torque of 80 in-lb (6.7 ft-lb or 0.92 Kg-m).

Fig. 2.5-1

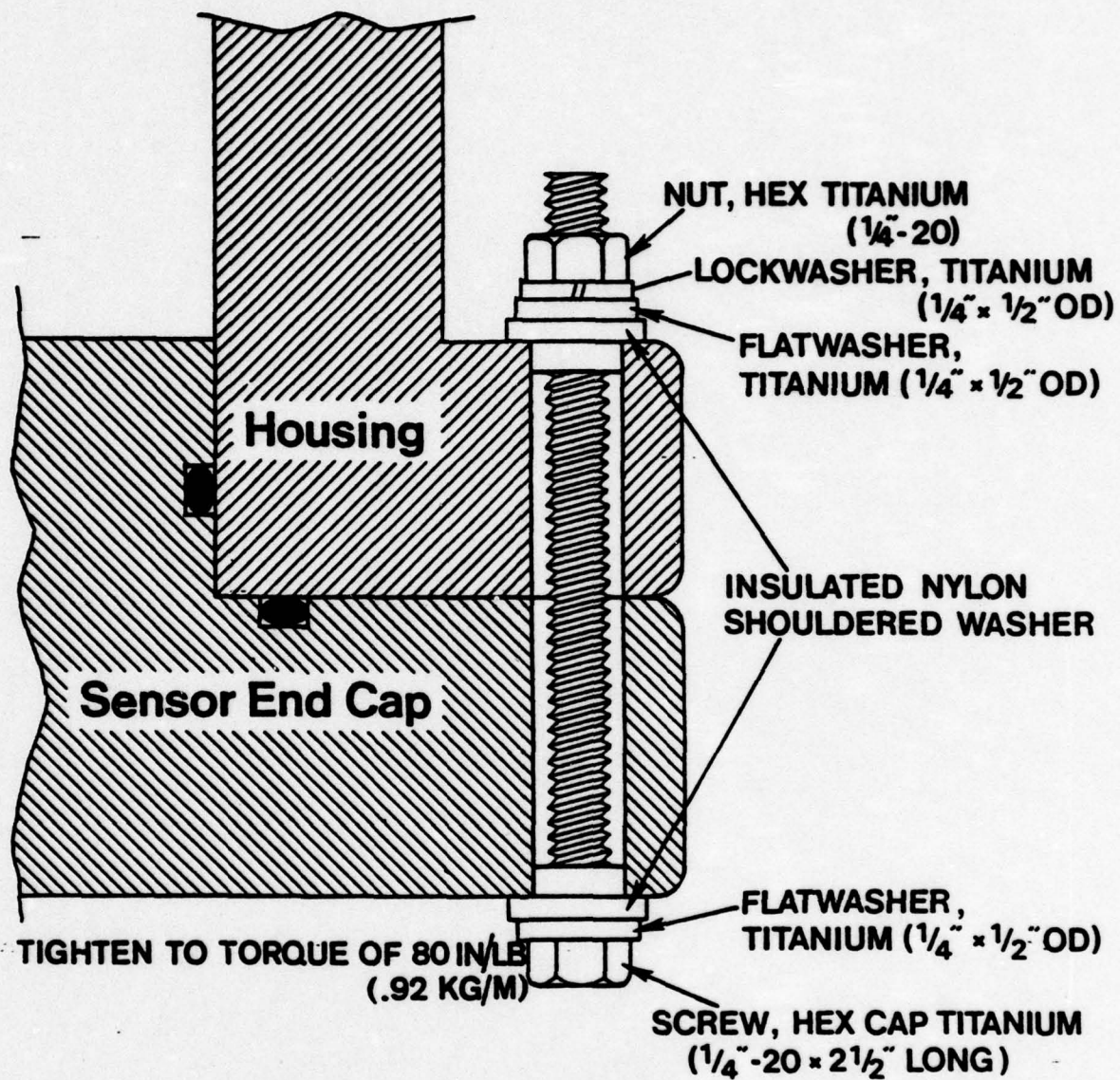

**DETAIL of SENSOR END - CAP BOLT HARDWARE**

**CLOSING ACCESS HATCH:**

1. If the unit is to have the clock set-
  - a. Connect Time Set/Data Readout box (or equivalent) through access hatch.
  - b. Set time and check data (see Section 2.6).
  - c. Disconnect Time Set/Data Readout box.
2. Place a small bag of desicant into housing through access hatch.
3. Purge unit with dry gas (dichlorodifluoromethane) by injecting gas through hatch into copper tube running length of card rack. Accomplish this with unit upright (access hatch on top) and purge until dry gas can be seen spilling out of hatch.
4. Quickly close access hatch by screwing clockwise (about four revolutions) until snug. Be sure "O" rings are clean and greased and mating surfaces are clean and free of scratches. Use a plastic or fiberglass straight edge in hatch groove to turn cap. DO NOT USE METAL TOOLS in order to avoid chipping the paint.

## SETTING CLOCK AND THROUGH HATCH CHECKS

After the ACM-1 has been powered-up and installed in its housing but before the access hatch is closed, the unit must have its time clock set and should be operationally checked. The "Time Set/Data Readout Box" (TSDR) is a versatile accessory designed to complement the ACM-1 and perform the following:

1. Setting of ACM-1 internal clock
2. Check-out of digital electronics
3. Check-out of analog electronics

If a TSDR box is available, follow the TSDR instructions to set the clock and verify the digital electronics. If a TSDR box is not available, the user may deploy the ACM-1 with the internal clock set for elapsed time rather than real-time. To set the clock to start at zero, momentarily jump connector J1 pin H (TIME RESET) to J1 pin K (BATTERY +8V). Record the time of this occurrence for later correction of elapsed time to real-time.

The analog signals of  $V_X$ ,  $V_Y$ ,  $H_X$ ,  $H_Y$ ,  $V_N$  and  $V_E$  are brought out on connector J1 (and made available on the front panel of the TSDR box). Refer to Table 1.2.3-1 for definitions of these signals. An operational check of these analog signals can be accomplished as follows:

1. Suspend the ACM-1 from an overhead support and immerse the sensor end of the instrument in stagnant bubble-free water. The sensors should be at least 30 cm below the surface and 30 cm from the sides of the container.
2. Align the sensor reference axis (NBIS ACM-1 logo on the housing or red dot on sensor "finger") toward North. Swing the meter toward North. This simulates a southerly current and the voltage  $V_X$  will show a negative swing.
3. Swing the meter South;  $V_X$  will go positive.
4. Swing the meter East;  $V_Y$  will go negative.
5. Swing the meter West;  $V_Y$  will go positive.
6. Align the ACM-1 so that the reference direction points North, then East, South and West. Measure  $H_X$  and  $H_Y$  at each position. The magnitude of the magnetic vector,  $(H_X^2 + H_Y^2)^{1/2}$ , will be about 1.0 dependent of the strength of the local field. The maximums and zeros occur as in the following table.

Reference to	$H_X$	$H_Y$
North	max +	0
East	0	max +
South	max -	0
West	0	max -

7. Align the ACM-1 so that the reference direction points in any arbitrary direction. Swing the ACM-1 toward North and verify that  $V_N$  dips negative. (Note that  $V_N$  and  $V_E$  are DC levels with AC signals present.)

8. Swing the meter South,  $V_N$  will go positive.
9. Swing the meter East,  $V_E$  will go negative.
10. Swing the meter West,  $V_E$  will go positive.

**PREDEPLOYMENT CHECK (HATCH CLOSED)**

Verify the mechanical integrity of the instrument before deployment. Be sure the access hatch is secured and all bolts are properly tightened.

Tune a transistor radio to about 1605 KHz and place it near the current-meter's acoustic transducers (these are the potted sensors at the ends of the four "fingers"). Any commercially available AM radio is acceptable. A clear tone of about 1000 Hz should be discernable. Fine tune the radio if necessary. The existence of this signal is evidence of the proper working of the meter.

## SPECIAL INSTRUCTIONS FOR BURST RECORDING METER

The burst recording meter will record data taken once per second every hour for 1 minute or 5 minutes (dependent on jumper J1 on the burst sequencer card). The hour interval is timed independent of the clock counter and data is first taken exactly 1 hour after the TIME RESET signal is applied by the user. (TIME RESET is applied through the electrical access hatch and via connector J1). Data is taken every hour thereafter.

In order to insure that data is taken at a particular time every hour (i.e. on the half-hour), the TIME RESET signal and TIME SET signal (see instructions for TSDR box) must be applied at the particular time. No data is taken at the TIME RESET; data is taken in burst mode 1 hour later and each hour subsequently. Burst mode data can be forced by connecting PIN 8 of the burst sequencer card (card 20) to  $V_{DD}$  (+6 volts). Data is taken as complete 5 second records until the OVERRIDE signal (Card 20--PIN 8) is removed. This OVERRIDE does not affect the hour timing.

The cassette tape capacity is slightly greater than four days of burst sampling at 5 minutes per hour. The lithium battery life is approximately 120 days of burst sampling at 5 minutes.

## DATA REDUCTION

Data, as recorded on cassette tape, must be read by a compatible reader and the data must then be converted to scientific units. The readers for the Memodyne and Sea Data options are discussed in Section 3.1. Section 3.2 deals with the format of the data on tape and Section 3.3 deals with the formula for converting the numbers as read from tape to scientific units.

## CASSETTE READERS

1. MEMODYNE OPTION: A compatible reader to the Memodyne Model 201 recorder must be used to read the ACM-1 data tapes. These readers are generally based on the Model 122 transports or the equivalent as an instrument, Model 3122 reader. A variety of interfaces can be provided including: RS232C; 20ma loop teletype; 9-track incremental IBM tape; GPIB; or eight bit parallel. The basic specifications of the reader must include the ability to read CNRZ Memodyne formatted data at densities of 615 to 1000 bpi. If desired, Neil Brown Instrument Systems can provide compatible readers.
2. SEA DATA OPTION: A compatible reader to the Sea Data Model 610 recorder must be used to read the ACM-1 data tapes. These readers are generally based on the Model 12A tape reader and include one or more output options such as the parallel computer output or 9-track tape drive interface. The basic specifications of the reader must include the ability to read four track 800 characters/inch phase encoded data. If desired, Neil Brown Instrument Systems can provide compatible readers.

## TAPE FORMAT DESCRIPTION

The ACM-1 acoustic current meter records data on cassette tape as 288 bits of data forming a record. Each record is separated by an inter-record gap. There is no file gapping. The Memodyne recorder uses 16 bit spaces for gaps. The Sea Data recorder writes a gap and a two step preamble before the data and a one step parity at the end of the 288 bit (72 step) data record. The data is recorded by both recorders with the most-significant-bit written on tape first. The first bit written (and therefore read) is labeled bit 1 and the last is bit 288. The format of the data as recorded is fully described by Table 3.2-1.

TABLE 3.2-1 CASSETTE TAPE FORMAT (AVERAGING)

Bits No. MSB to LSB	Data	Description	Maximum Count
1 to 8	Header	Jumper selected header bits	255
9 to 20	$N_{V_{N1}}$	North-South velocity component average for the N minutes ending at ( $N_{Time} - 9*N$ ) minutes.	4095
21 to 32	$N_{V_{E1}}$	East-West velocity component average for the N minutes ending at ( $N_{Time} - 9*N$ ) minutes.	4095
33 to 44, 45 to 56	$N_{V_{N2}}, N_{V_{E2}}$	same as above for ( $N_{Time} - 8*N$ )	4095
57 to 68, 69 to 80	$N_{V_{N3}}, N_{V_{E3}}$	same as above for ( $N_{Time} - 7*N$ )	4095
81 to 92, 93 to 104	$N_{V_{N4}}, N_{V_{E4}}$	same as above for ( $N_{Time} - 6*N$ )	4095
105 to 116, 117 to 128	$N_{V_{N5}}, N_{V_{E5}}$	same as above for ( $N_{Time} - 5*N$ )	4095
129 to 140, 141 to 152	$N_{V_{N6}}, N_{V_{E6}}$	same as above for ( $N_{Time} - 4*N$ )	4095
153 to 164, 165 to 176	$N_{V_{N7}}, N_{V_{E7}}$	same as above for ( $N_{Time} - 3*N$ )	4095
177 to 188, 189 to 200	$N_{V_{N8}}, N_{V_{E8}}$	same as above for ( $N_{Time} - 2*N$ )	4095
201 to 212, 213 to 224	$N_{V_{N9}}, N_{V_{E9}}$	same as above for ( $N_{Time} - 1*N$ )	4095
225 to 236, 237 to 248	$N_{V_{N10}}, N_{V_{E10}}$	same as above for $N_{Time}$	

TABLE 3.2-1 CASSETTE TAPE FORMAT (AVERAGING) (CONT.)

Bits No. MSB to LSB	Data	Description	Maximum Count
249 to 256	$N_{Temp}$	Average temperature prior to recording	255
257 to 264	$N_{Comp}$	Instantaneous compass heading prior to recording	255
265 to 268	Status	Proper operation indicated by zeros. a) BIT 265 Oscillator lock b) BIT 266 Acoustic filter, X axis c) BIT 267 Acoustic filter, Y axis d) BIT 268 not used (Jumpered to 0)	0 or 1 0 or 1 0 or 1 0 or 1
269 to 288	$N_{Time}$	Time at instant of recording in count of minutes	1,048,575

Note: N is jumper selected on the ACM-1 card rack and works out to be as follows:

$$N = (N_{Time_i} - N_{Time_{i-1}}) / 10$$

where the subscripts refer to any two times for consecutive records.

TABLE 3.2-1 CASSETTE TAPE FORMAT  
(AVERAGING - SPECIAL TEMPERATURE) (CONT.)

Bits No. MSB to LSB	Data	Description	Maximum Count
249 to 256	$N_{Comp}$	Instantaneous compass heading prior to recording	255
257 to 272	$N_{Time}$	Time at instant of recording in count of minutes. (Note: User must keep track of MSB's beyond the 16 bits)	65,535
273 to 284 *	$N_{Temp}$	Average Temperature prior to recording (LSB to MSB)	4095
285 to 288	Dummy	Not used	----

Note: N is jumper selected on the ACM-1 card rack and works out to be as follows:

$$N = (N_{Timei} - N_{Timei-1}) / 10$$

where the subscripts refer to any two times for consecutive records.

\*LSB first; Bit 284 is MSB and Bit 273 is LSB.

TABLE 3.2-1 CASSETTE TAPE FORMAT (BURST)

Bits No. MSB to LSB	Data	Description	Maximum Count
1 to 8	Header	Jumper selected header bits	255
9 to 16	$N_{HX1}$	X axis compass component	255
17 to 24	$N_{HY1}$	Y axis compass component	255
25 to 36	$N_{VX1}$	X axis velocity component	4095
37 to 48	$N_{VY1}$	Y axis velocity component	4095
49 to 57, 58 to 64	$N_{HX2}, N_{HY2}$	X, Y axis compass components	255
65 to 76, 77 to 88	$N_{VX2}, N_{VY2}$	X, Y axis velocity components	4095
89 to 96, 97 to 104	$N_{HX3}, N_{HY3}$	X, Y axis compass components	255
105 to 116, 117 to 128	$N_{VX3}, N_{VY3}$	X, Y axis velocity components	4095
129 to 136, 137 to 144	$N_{HX4}, N_{HY4}$	X, Y axis compass components	255
145 to 156, 157 to 168	$N_{VX4}, N_{VY4}$	X, Y axis velocity components	4095
169 to 176, 177 to 184	$N_{HX5}, N_{HY5}$	X, Y axis compass components	255
185 to 196, 197 to 208	$N_{VX5}, N_{VY5}$	X, Y axis compass components	4095
209 to 220	$N_{TEMP}$	Average temperature prior to recording	4095
221 to 232	$N_{ZERO}$	Digitized value of reference zero volts	4095
233 to 244	$N_{THREE}$	Digitized value of reference three volts	4095

Bits No. MSB to LSB	Data	Description	Maximum Count
245 to 256	$N_{SIX}$	Digitized value of reference six volts	4095
257 to 260	STATUS	Proper operation indicated by zero (a) BIT 257 Oscillator lock (b) BIT 258 Acousticfilter, X axis c) BIT 259 Acousticfilter, Y axis d) BIT 260 not used (jumpered to 0)	0 or 1 0 or 1 0 or 1 0 or 1
261 to 280	$N_{TIME}$	Time at instant of recording in count of minutes	1,048,575
280 to 288	DUMMY	Not used	255

Note: The five samples of  $N_{HX}$ ,  $N_{HY}$ ,  $N_{VX}$  and  $N_{VY}$  occur once each second for five seconds sometime during the minute indicated by  $N_{TIME}$ .

TABLE 3.2-1 CASSETTE TAPE FORMAT (AVERAGING W/2 TEMPERATURES)

BITS NO. MSB to LSB	DATA	DESCRIPTION	MAXIMUM COUNT
1 to 8	Header	Jumper selected header bits	255
9 to 20	$N_{V_{N1}}$	North-South velocity component average for the N minutes ending at $(N_{Time} - 7*N)$ minutes	4095
21 to 32	$N_{V_{E1}}$	East-West velocity component for the N minutes ending at $(N_{Time} - 7*N)$ minutes.	4095
33 to 44, 45 to 56	$N_{V_{N2}}, N_{V_{E2}}$	same as above for $(N_{Time} - 6*N)$	4095
57 to 68, 69 to 80	$N_{V_{N3}}, N_{V_{E3}}$	same as above for $(N_{Time} - 5*N)$	4095
81 to 92, 93 to 104	$N_{V_{N4}}, N_{V_{E4}}$	same as above for $(N_{Time} - 4*N)$	4095
105 to 116, 117 to 128	$N_{V_{N5}}, N_{V_{E5}}$	same as above for $(N_{Time} - 3*N)$	4095
129 to 140, 141 to 152	$N_{V_{N6}}, N_{V_{E6}}$	same as above for $(N_{Time} - 2*N)$	4095
153 to 164, 165 to 176	$N_{V_{N7}}, N_{V_{E7}}$	same as above for $(N_{Time} - 1*N)$	4095
177 to 188, 189 to 200	$N_{V_{N8}}, N_{V_{E8}}$	same as above for $N_{Time}$	4095
201 to 212	$N_{T_{A1}}$	Temperature average at sensor A for the N minutes ending at $(N_{Time} - 7*N)$ minutes	4095
213 to 224	$N_{T_{B1}}$	Temperature average at sensor B for the N minutes ending at $(N_{Time} - 7*N)$ minutes	4095
225 to 248	$N_{T_{A2}}, N_{T_{B2}}$	Same as above for $(N_{Time} - 5*N)$	4095

TABLE 3.2-1 CASSETTE TAPE FORMAT (AVERAGING W/2 TEMPERATURES)

(Continued)

BITS NO. MSB to LSB	DATA	DESCRIPTION	MAXIMUM COUNT
249 to 272	$N_{TA3}, N_{TB3}$	same as above for $(N_{Time}^{-5*N})$	4095
273 to 296	$N_{TA4}, N_{TB4}$	same as above for $(N_{Time}^{-4*N})$	4095
297 to 320	$N_{TA5}, N_{TB5}$	same as above for $(N_{Time}^{-3*N})$	4095
321 to 344	$N_{TA6}, N_{TB6}$	same as above for $(N_{Time}^{-2*N})$	4095
345 to 368	$N_{TA7}, N_{TB7}$	same as above for $(N_{Time}^{-N})$	4095
369 to 392	$N_{TA8}, N_{TB8}$	same as above for $N_{Time}$	4095
393 to 400	$N_{Comp}$	Instantaneous compass heading prior to recording	255
401 to 404	Status	Proper operation indicated by zeros. a) BIT 401 Oscillator lock b) BIT 402 Acoustic filter, X axis c) BIT 403 Acoustic filter, Y axis d) BIT 404 not used (Jumpered to 0)	0 or 1 0 or 1 0 or 1 0 or 1
405 to 424	$N_{Time}$	Time at instant of recording in count of minutes	1,048,575

Note: N is jumper selected on the ACM-1 card rack and works out to be as follows:

$$N = (N_{Time_i} - N_{Time_{i-1}}) / 8$$

where the subscripts refer to any two times for consecutive records.

## CONVERSION OF RECORDED DATA TO SCIENTIFIC UNITS

1. Time: Time is recorded as binary minutes and can be converted to days, hours and minutes as follows:

$$\text{DAYS} = \text{INT} (N_{\text{time}}/1440) \quad (1)$$

$$\text{HOURS} = \text{INT} \{(N_{\text{time}} - \text{DAYS} * 1440) / 60\} \quad (2)$$

$$\text{MINUTES} = N_{\text{time}} - \text{DAYS} * 1440 - \text{HOURS} * 60 \quad (3)$$

where

$N_{\text{time}}$  = time data as recorded on tape

$\text{INT}(-)$  = integer result of enclosed expression

$\text{DAYS}$  = number of days

$\text{HOURS}$  = number of hours (0 to 23)

$\text{MINUTES}$  = number of remaining minutes (0 to 59)

2. HEADING: The compass word is eight bits of instrument heading with LSB weight equal  $1.5^{\circ}$ . The heading in degrees relative to magnetic North is given by equation (4). Note that this heading is only useful as a check on operation and is not required in order to use the velocity data.

$$\text{HEADING} = N_{\text{compass}} * 1.5 \quad (4)$$

where

$N_{\text{compass}}$  = compass data as recorded on tape.

$\text{HEADING}$  = instrument heading in degrees relative magnetic North.

3. TEMPERATURE: The eight bit temperature word is converted to degrees celcius by equation (5).

$$T = N_{Temp} (38.25/255) - 2.4 \quad (5)$$

where

$N_{Temp}$  = temperature data as recorded on tape

T = temperature in degrees celcius

4. VELOCITY: The North-South and East-West water velocity components are each represented by 12 bits. The conversion of velocity data to cm/sec is given below.

$$U_N = ((N_{VEL_N} - 2048)/2048)(C^2K/4df) \quad (6)$$

$$U_E = ((N_{VEL_E} - 2048)/2048)(C^2K/4df) \quad (7)$$

where

$N_{VEL_N}, N_{VEL_E}$  = velocity data as recorded on tape for North-South and East-West component data respectively

$U_N, U_E$  = component velocity in cm/sec for North-South and East-West respectively

C = speed of sound in water in cm/sec (See Item 5 below)

K = calibration factor (normally = 1.000)

d = transducer spacing = 11.4 cm.

f = acoustic frequency = 1605000 Hz

Note that the derivations for equations (6) and (7) are given in the Appendix.

5. SOUND VELOCITY: The velocity of sound is required to calculate the water current velocities. The speed of sound is given by equation (8).

3. TEMPERATURE: The twelve bit temperature word is converted to degrees celcius by equation (5).

$$T = N_{Temp}/100^{-2.56} \quad (5)$$

where

$N_{Temp}$  = temperature data as recorded on tape

T = temperature in degrees celcius

4. VELOCITY: The North-South and East-West water velocity components are each represented by 12 bits. The conversion of velocity data to cm/sec is given below.

$$U_N = ((N_{VEL_N} - 2048)/2048)(C^2K/4df) \quad (6)$$

$$U_E = ((N_{VEL_E} - 2048)/2048)(C^2K/4df) \quad (7)$$

where

$N_{VEL_N}, N_{VEL_E}$  = velocity data as recorded on tape for North-South and East-West component data respectively

$U_N, U_E$  = component velocity in cm/sec for North-South and East-West respectively

C = speed of sound in water in cm/sec (See Item 5 below)

K = calibration factor (normally = 1.000)

d = transducer spacing = 11.4 cm.

f = acoustic frequency = 1605000 Hz

Note that the derivations for equations (6) and (7) are given in the Appendix.

5. SOUND VELOCITY: The velocity of sound is required to calculate the water current velocities. The speed of sound is given by equation (8).

$$C/100 = 1449 + 4.6T - 0.055T^2 + 0.0003T^3 + (1.39 - 0.012T)(S - 35) + 0.017D \quad (8)$$

where

- C = Speed of sound in water in cm/sec.  
 T = Temperature in degrees celcius  
 S = Salinity in parts per thousand  
 D = depth below surface in meters

The temperature data is as calculated in Item 3 above and the depth is the known deployment depth. The effects of salinity on calculated water current velocity is less than 0.2% per one part per thousand change in salinity. Therefore by using an average salinity value, the effects of salinity changes will be minimal and can be ignored.

6. CURRENT SPEED AND DIRECTION: The water current components can be converted to speed and direction as follows:

$$\text{SPEED} = (U_N^2 + U_E^2)^{1/2} \quad (9)$$

$$\text{DIRECTION}_{\text{MAG}} = \text{TAN}^{-1}(U_E/U_N) \quad (\text{resolve } 0 \text{ to } 360^\circ) \quad (10)$$

where

- $U_N, U_E$  = Component of velocity in cm/sec for North-South and East-West respectively (See Item 4)

SPEED = current vector magnitude in cm/sec

$\text{DIRECTION}_{\text{MAG}}$  = Vector orientation relative to magnetic North.

7. DIRECTION RELATIVE TRUE NORTH: The direction from equation (10) is relative magnetic North. The correction to true North is given by equation (11).

$$\text{DIRECTION}_{\text{TRUE}} = \text{DIRECTION}_{\text{MAG}} \pm \text{VARIATION} \quad (11)$$

where

$\text{DIRECTION}_{\text{MAG}}$  = vector orientation relative to magnetic North  
(See Item 6)

$\text{VARIATION}$  = correction as read from navigational charts  
(degrees east or west)

$\text{DIRECTION}_{\text{TRUE}}$  = vector orientation relative to true North

Note: Add East VARIATION and subtract West VARIATION.

## CONVERSION OF RECORDED BURST DATA TO SCIENTIFIC UNITS

1. TIME: Time is recorded as binary minutes and can be converted to days, hours and minutes as follows:

$$\text{DAYS} = \text{INT} (N_{\text{time}}/1440) \quad (1)$$

$$\text{HOURS} = \text{INT} ((N_{\text{time}} - \text{DAYS} * 1440) / 60) \quad (2)$$

$$\text{MINUTES} = N_{\text{time}} - \text{DAYS} * 1440 - \text{HOURS} * 60 \quad (3)$$

where

$N_{\text{time}}$  = time data as recorded on tape

$\text{INT}(-)$  = integer result of enclosed expression

$\text{DAYS}$  = number of days

$\text{HOURS}$  = number of hours (0 to 23)

$\text{MINUTES}$  = number of remaining minutes (0 to 59)

2. TEMPERATURE: The twelve bit temperature is converted to degree Celcius by equation (4)

$$T = N_{\text{Temp}} * M_{\text{s/n}} + B_{\text{s/n}} \quad (4)$$

where

$N_{\text{Temp}}$  = temperature data as recorded on tape

$T$  = temperature in degrees celcius

$M_{\text{s/n}}, B_{\text{s/n}}$  = calibration constants particular to the specific unit.

3.  $H_x, H_y, V_x, V_y$ : The compass and velocity components are first converted to relative fullscale values dependent on the reference voltage data.

$$(a) \text{ If } N_{\text{HX}} * 256 \geq N_{\text{Three}} \quad (5)$$

$$\text{then } H_x = (N_{\text{HX}} * 256 - N_{\text{Three}}) / (N_{\text{Six}} - N_{\text{Three}})$$

$$\text{else } H_x = (N_{\text{HX}} * 256 - N_{\text{Three}}) / (N_{\text{Three}} - N_{\text{Zero}})$$

$$(b) \text{ If } N_{HY} * 256 \geq N_{Three} \quad (6)$$

$$\text{then } H_Y = (N_{HY} * 256 - N_{Three}) / (N_{Six} - N_{Three})$$

$$\text{else } H_Y = (N_{HY} * 256 - N_{Three}) / (N_{Three} - N_{Zero})$$

$$(c) \text{ If } N_{VX} \geq N_{Three} \quad (7)$$

$$\text{then } V_X = (3/2) * (N_{VX} - N_{Three}) / (N_{Six} - N_{Three})$$

$$\text{else } V_X = (3/2) * (N_{VX} - N_{Three}) / (N_{Three} - N_{Zero})$$

$$(d) \text{ If } N_{VY} \geq N_{Three} \quad (8)$$

$$\text{then } V_Y = (3/2) * (N_{VY} - N_{Three}) / (N_{Six} - N_{Three})$$

$$\text{else } V_Y = (3/2) * (N_{VY} - N_{Three}) / (N_{Three} - N_{Zero})$$

where

$N_{HX}, N_{HY}, N_{VX}, N_{VY}$  = compass and velocity component data as recorded on tape.

$H_X, H_Y, V_X, V_Y$  = relative fullscale components.

$N_{Six}, N_{Three}, N_{Zero}$  = Reference voltage data as recorded on tape.

4. VELOCITY: The North-South and East-West velocity components must be resolved from the velocity and compass components and converted to cm/sec dependent on the speed of sound for the water at the time of measurement.

$$U_N = \frac{(V_X H_X - V_Y H_Y)}{(H_X^2 + H_Y^2)^{1/2}} \quad (C^2 K / 4df) \quad (9)$$

$$U_E = \frac{(V_X H_Y + V_Y H_X)}{(H_X^2 + H_Y^2)^{1/2}} \quad (C^2 K / 4df) \quad (10)$$

where

$V_X, V_Y, H_X, H_Y$  = relative fullscale components (from Item 3 above).

- $U_N, U_E$  = component velocity in cm/sec for North-South and East-west respectively
- C = speed of sound in water in cm/sec (See Item 5 below)
- K = calibration factor (normally = 1.000)
- d = transducer spacing = 11.4 cm.
- f = acoustic frequency = 1605000 Hz

Note that the derivations for equations (9) and (10) are given in the Appendix.

5. SOUND VELOCITY: The velocity of sound is required to calculate the water current velocities. The speed of sound is given by equation (11).

$$C/100 = 1449 + 4.6T - 0.055T^2 + 0.0003T^3 + (1.39 - 0.012T)(S - 35) + 0.017D \quad (11)$$

where

- C = Speed of sound in water in cm/sec.
- T = Temperature in degrees celcius
- S = Salinity in parts per thousand
- D = depth below surface in meters

The temperature data is as calculated in Item 2 above and the depth is the known deployment depth. The effects of salinity on calculated water current velocity is less than 0.2% per one part per thousand change in salinity. Therefore by using an average salinity value, the effects of salinity changes will be minimal and can be ignored.

6. CURRENT SPEED AND DIRECTION: The water current components can be converted to speed and direction as follows:

$$\text{SPEED} = (U_N^2 + U_E^2)^{1/2} \quad (11)$$

$$\text{DIRECTION}_{\text{MAG}} = \text{TAN}^{-1}(U_E/U_N) \quad (12)$$

where

$U_N, U_E$  = Component of velocity in cm/sec for North-South and East-West respectively (See Item 4)

SPEED = current vector magnitude in cm/sec

$\text{DIRECTION}_{\text{MAG}}$  = Vector orientation relative to magnetic North.

7. DIRECTION RELATIVE TRUE NORTH: The direction from equation (12) is relative magnetic North. The correction to true North is given by equation (13).

$$\text{DIRECTION}_{\text{TRUE}} = \text{DIRECTION}_{\text{MAG}} \pm \text{VARIATION} \quad (13)$$

where

$\text{DIRECTION}_{\text{MAG}}$  = vector orientation relative to magnetic North  
(See Item 6)

VARIATION = correction as read from navigational charts  
(degrees east or west)

$\text{DIRECTION}_{\text{TRUE}}$  = vector orientation relative to true North

Note: Add East VARIATION and subtract West VARIATION.

## FUNCTIONAL AND CIRCUIT DESCRIPTION

The NEIL BROWN INSTRUMENT SYSTEMS Acoustic Current Meter Model ACM-1 is an internally powered true vector averaging water current meter with cassette recorder. Refer to Figure 4.0-1 for the "Current Meter Functional Block Diagram". Voltages proportional to the rectangular components of water velocity ( $V_x$  and  $V_y$ ) and to the rectangular components of local magnetic field ( $H_x$  and  $H_y$ ) are generated. These signals are referenced to the instrument's axes. These functions are discussed in Section 4.1, "Velocity Function", and Section 4.2, "Compass Function". The velocity signals and compass signals are combined to produce velocity signals referenced to the earth's magnetic axes of North-South and East-West. These signals, referred to as  $V_N$  and  $V_E$ , are converted to digital frequencies which are used to accumulate data on a continuous basis. This function is described in Section 4.3, "Signal Processing Function".

Power from the battery back is regulated from a nominal +8.0 volts to +6.0 and +3.0 volts. The +6.0 and 0 volts are used as  $V_{DD}$  and  $V_{SS}$  for the CMOS logic. The +6.0, +3.0 and 0 volts serve as the  $V+$ , analog common, and  $V-$  respectively of the analog circuits. This function and the generation of the various timing signals is discussed in Section 4.4, "Power and Timing Function"

Temperature data is used with the known deployment depth and salinity by the user to correct the current velocity data. The effect of sound velocity on the acoustic measurement is discussed fully in Section 3.0.

The collection of the temperature data and keeping track of time is discussed in Section 4.5, "Time, Temperature, and Accumulating Function".

The accumulated velocity components, time, and temperature along with four status flag bits and a header are recorded on cassette tape. This function is discussed in Section 4.6, "Recording Function (Memodyne)" and Section 4.7, "Recording Function (Sea Data)". Note that the ACM-1 is provided with either a Memodyne or a Sea-Data recorder.

Fig. 4.0-1

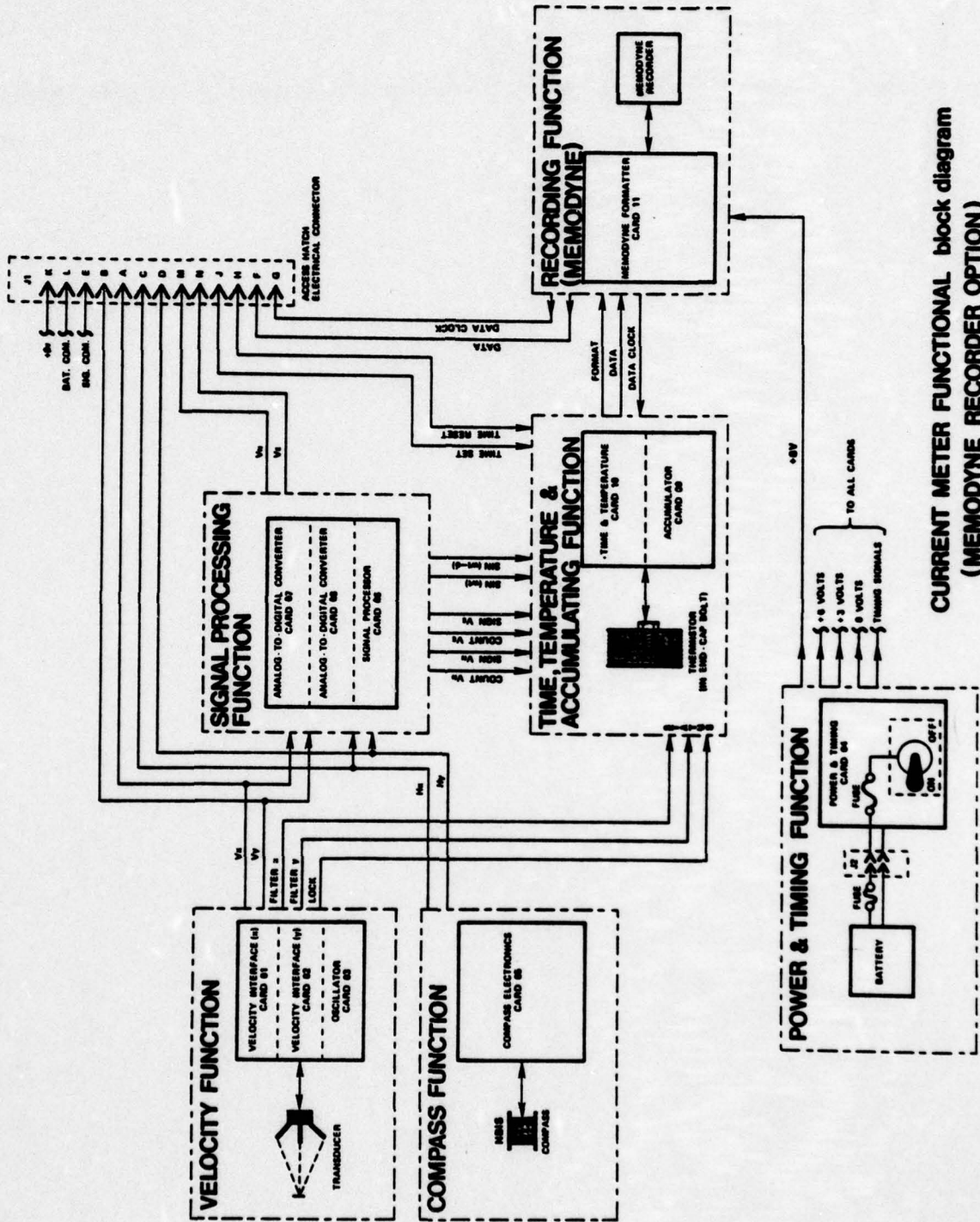

CURRENT METER FUNCTIONAL block diagram  
(MEMODYNE RECORDER OPTION)

Fig. 4.0-2

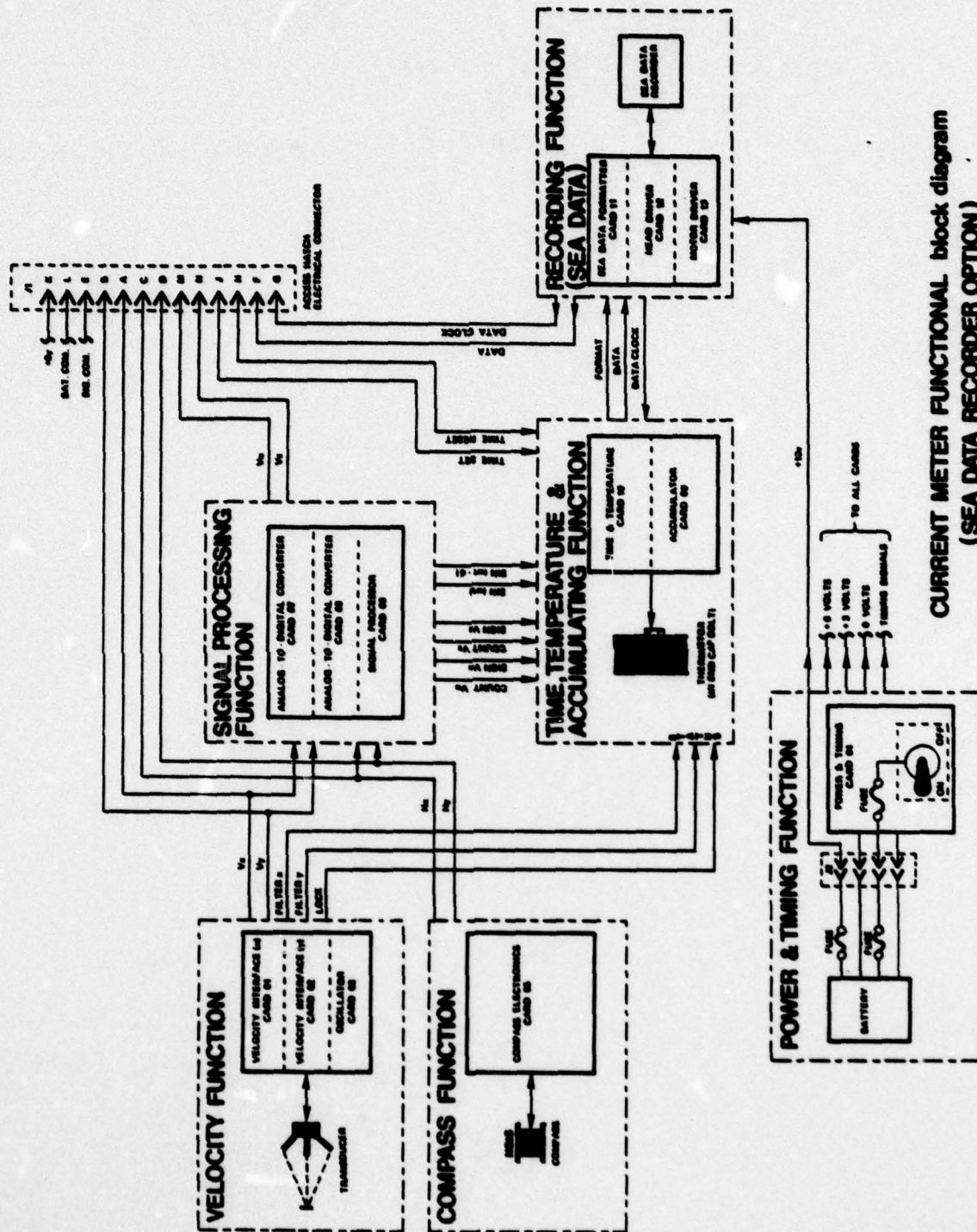

CURRENT METER FUNCTIONAL block diagram  
(SEA DATA RECORDER OPTION)

## VELOCITY FUNCTION

The measurement of water current in terms of vector components referenced to the rectangular coordinates of the instrument is functionally blocked out in Figure 4.1-1. This function is accomplished by means of a transducer, two velocity interface cards, and one velocimeter oscillator card. The detailed operation of each of these is discussed in the following subsections. Note that current direction is always referenced to the point the water is flowing toward (i.e. positive X current flows in the positive X direction). The velocity transducer and its electronics measure the water current flow in a plane perpendicular to the meter axis of symmetry as two components  $V_X$  and  $V_Y$ .

$$V_X = VK_C \cos (\gamma) \quad (1)$$

$$V_Y = VK_C \sin (\gamma) \quad (2)$$

where  $V$  = strength of water current in the plane perpendicular to the meter axis (cm/sec);  $K_C$  = scaling constant (volts/cm/sec) as a function of sound velocity, acoustic frequency, and transducer spacing;  $\gamma$  = orientation of water current vector to ACM-1 reference +X axis; and  $V_X$  and  $V_Y$  are the voltage representations of the components of current in the package +X and +Y current axes. (See Figure 4.1-2).

Basically what occurs in the acoustic measurement of water current is that high frequency sound is transmitted in opposite paths through the water and the differences of the received signals is used to detect the water current. Refer to Figure 4.1-3. High frequency sound is emitted at A and travels to B;

Fig. 4.1-1

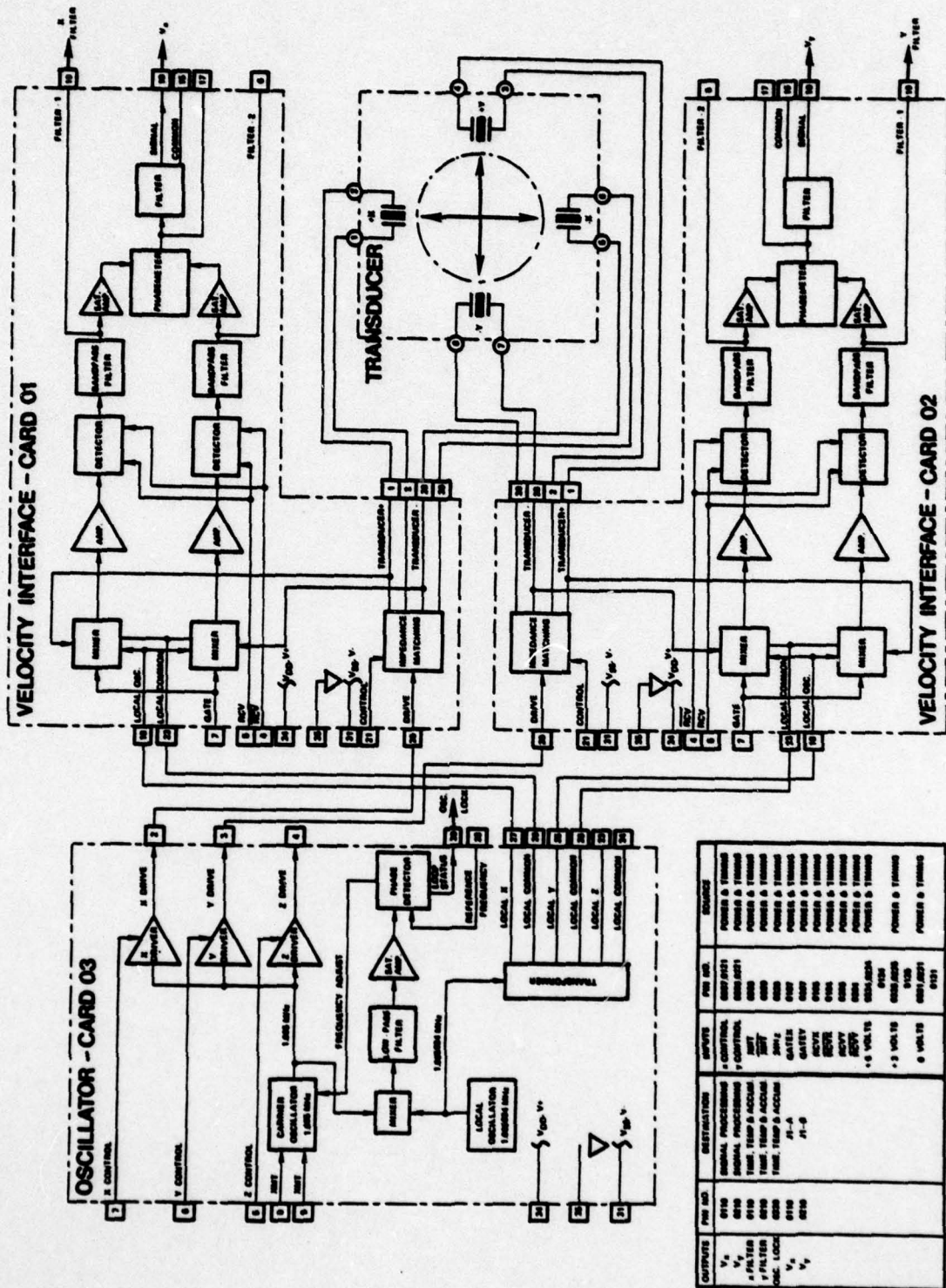

VELOCITY FUNCTION block diagram

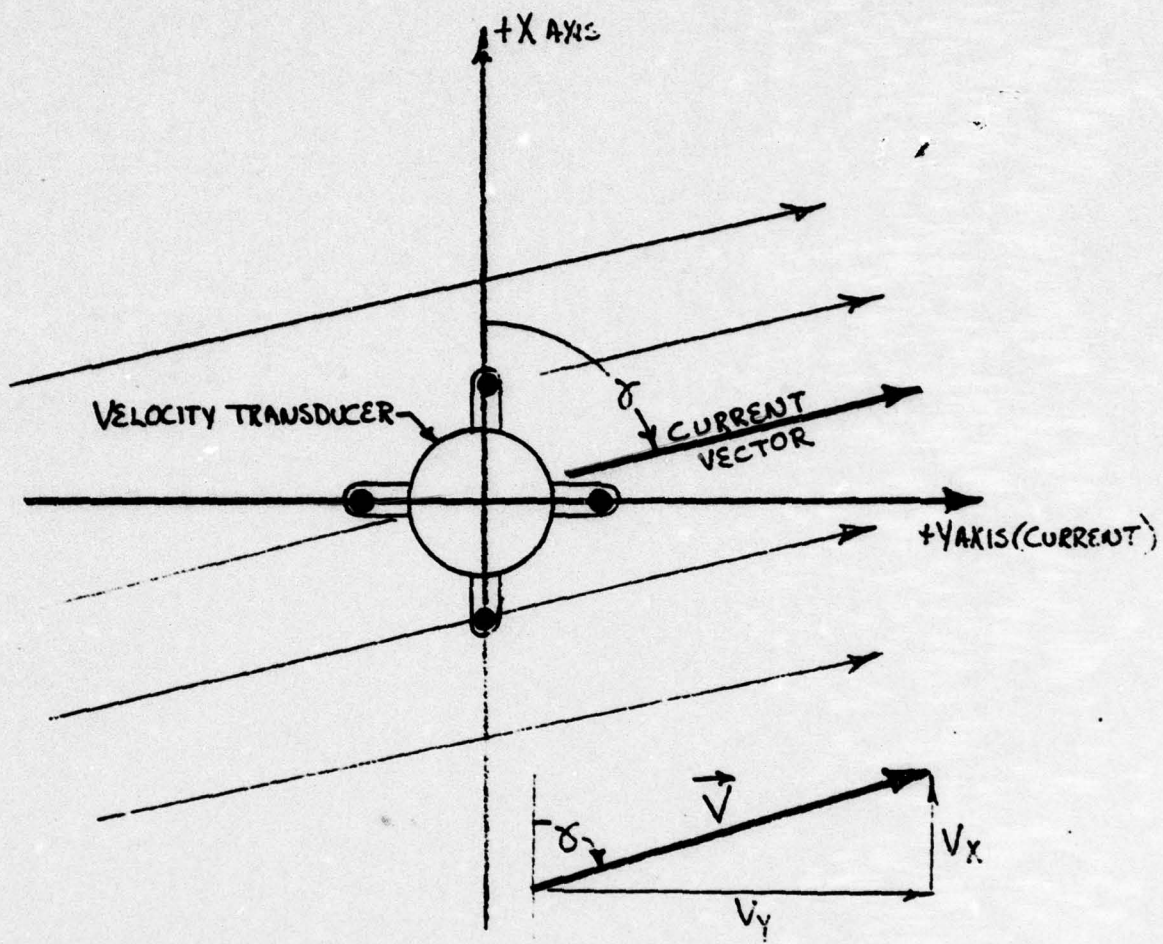

VIEW LOOKING DOWN  
CURRENT METER AXIS  
OF SYMMETRY

FIGURE 4.1-2 EXAMPLE ORIENTATION OF CURRENT TO ACM-1  
VELOCITY TRANSDUCER +X AXIS AND +Y AXIS (CURRENT)

40023C

Fig. 4.1-3

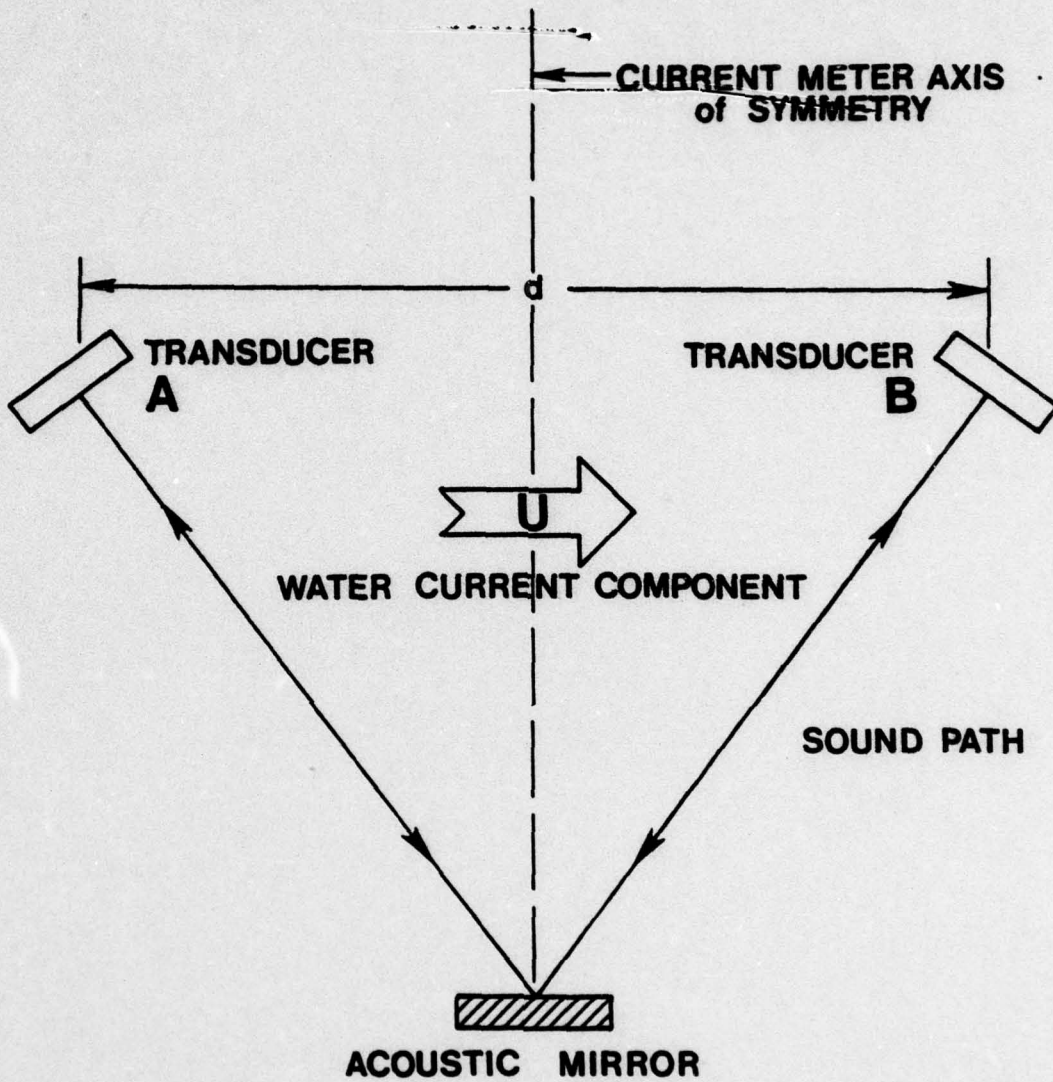

**ACOUSTIC CURRENT METER SENSOR GEOMETRY**

similarly sound is emitted at B and received at A. In the presence of water current,  $U$ , the signal traveling with the current will be advanced in phase and the signal traveling against the current will be retarded in phase. The result is that the relative phase between signals received at A and B will depend on 1) the acoustic frequency; 2) the spacing between A and B; 3) the local speed of sound; and 4) the water velocity. Items 1 and 2 are known; item 3 can be assumed and corrected for later knowing temperature, depth and salinity; and item 4 is the desired response. It can be shown that the dimension of importance is the horizontal spacing shown in Figure 4.1-2 as 'd' and that only the component of velocity parallel with line AB is measured.

To detect a 1 cm/sec water current, a direct phase measurement at the acoustic frequency (about 1.6MHz) would require time discrimination of less than a nanosecond ( $1 \times 10^{-9}$  seconds). This is difficult to achieve with straight forward low-power electronic circuitry. To circumvent this problem, the signals at A and B are heterodyned with a slightly offset frequency (about 1.6MHz plus 34Hz). The 34Hz difference frequency resulting from the mixing process contains the phase information of the original acoustic signal. The time discrimination at this frequency is 50,000 times less stringent and can easily be achieved by simple low noise/low power electronics.

AD-A070 721

BROWN (NEIL) INSTRUMENT SYSTEMS INC CATAUMET MA  
THREE AXIS ACOUSTIC CURRENT METER.(U)  
MAY 79

F/G 14/2

UNCLASSIFIED

N00014-75-C-0113  
NL

2 of 3

AD  
A070721



This microfiche contains 120 frames of technical information. The frames are arranged in a 10x12 grid. The content includes:

- Textual descriptions and specifications.
- Block diagrams of the instrument's internal components.
- Waveform plots showing signal characteristics.
- Photographs of the physical device.
- Tables of data or performance metrics.
- Various schematic diagrams and component layouts.

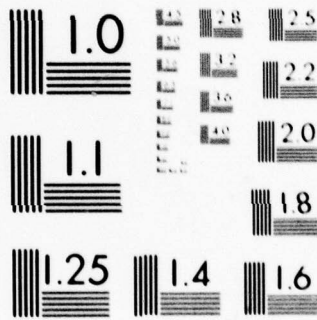

MICROCOPY RESOLUTION TEST CHART  
NATIONAL BUREAU OF STANDARDS-1963-A

## VELOCITY TRANSDUCER

The acoustic transducers must transmit and receive signals traveling with and against the water current. The easiest way to do this is to aim the transducers at one another and measure the movement of water along the line of aiming. The drawback to this approach is that the transducers inevitably block part of the flow, thereby reducing the output of the sensor and increasing the noise. The affect is greatest for currents directly in line with the sensors and diminishes at large attack angles; this causes a serious departure from ideal (cosine) response.

The ACM-1 circumvents the blockage problem by utilizing a triangular geometry which makes use of an acoustic mirror. This arrangement is shown in Figure 1.2.5-2 and Figure 4.1-2. Acoustic signals are aimed at the mirror and are reflected as shown. The differential affect of the water current on travel time (phase shift) will be exactly the same as if the signal had traveled directly from A to B. Vertical currents are not sensed by this geometry because the signals travel equal distances up and down. Any phase shift incurred in the downward travel subtracts from phase shift incurred on the way up. The mirror does not require optical qualities. Its surface irregularities need only be small compared to a wave length of sound at the acoustic frequency (less than 1 mm).

The mirror is supported by a titanium rod cage used also to

carry mooring tension. This is a very robust structure competent to operate with the rigors of deep water deployment. The rods have a diameter of 0.375 inches (0.95 cm) and are placed around the velocity sensor off-angle to the sound paths. Wakes from the rods cross the sound paths at 45 degrees thus minimizing the blockage effects. The cage assembly offers considerable mechanical protection to the sensor/mirror assembly.

It is important to note that the position of the mirror plays no part in determining the response of the sensor. If the mirror is not in exact position (for example, because the mooring has stretched the tension rods) the only effect will be to reduce slightly the amplitude of the acoustic signals. Since the method is sensitive only to phase, the meter's sensitivity, linearity, and stability will be unchanged. The position of acoustic mirror need only be maintained within about 1cm (in order to be within the beam).

The actual acoustic transducer is a piezo-electric transducer in the form of a small disc. Piezo-electric materials produce an electric charge (with resulting electric field) when strained. Conversely, a mechanical force is produced within the material when it is subjected to an electric field. Consequently, a piezo-electric disc transducer in an acoustic pressure field (i.e. acting as a receiver) will have forces produced at its surface resulting in an electric charge (with resulting electric field). When a piezo-electric transducer is used as a generator (i.e. acting as a transmitter) a force will be generated

proportional to the applied electric field and acoustic pressures will result. It can be shown that if the transducers in the transmitting mode are driven from exactly the same voltage and if in the receiving mode they are shunted by very low resistors then the phase differences between transmit mode and receive mode are equal and can be ignored. The practical implementation of this principle is discussed in the next sections.

The equivalent circuit for the piezo-electric transducers at frequencies close to their fundamental resonance (the actual operating frequency) is shown for transmit and receive in Figure 4.1.1-1. A rough check of the transducers can be made by measuring the capacitance looking into the transducer with the interface circuitry disconnected.

Capacitance<sub>g</sub> 580 to 650pf

An additional check is to check isolation of the transducer leads to the housing.

R >2 Mohm  
ISOLATION

The piezo-electric disc transducers are potted into the arms of an aluminum casting. The electrical leads from the transducer enter the main instrument housing through glass-metal hermetically sealed pins located within the sensor assembly. The transducer side is oil filled and is protected from the environment by means of a pressure balancing rubber diaphragm and plexiglass disc held in place by means of four nylon screws. The sensor assembly mounts on an extension tube; connections from the sensor assembly enter the main housing through the

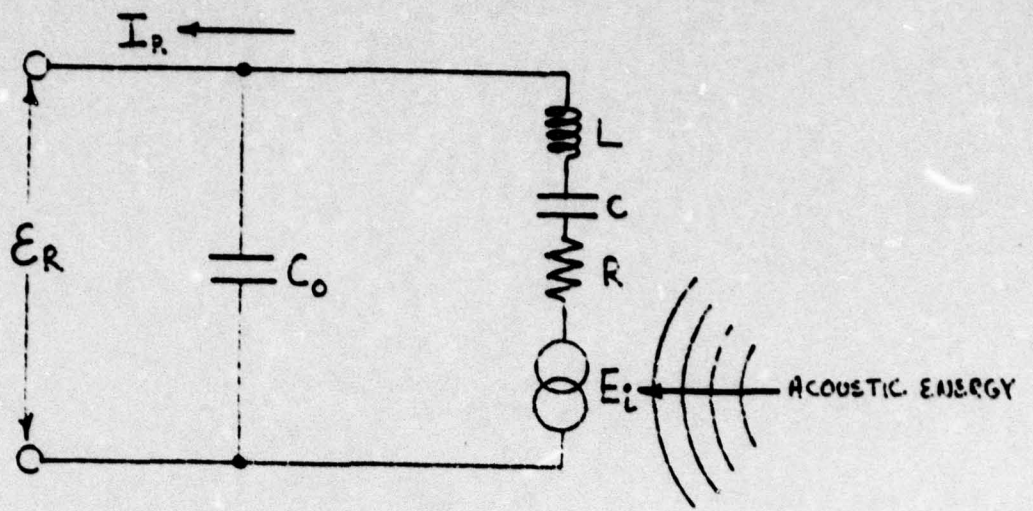

RECEIVE MODE.

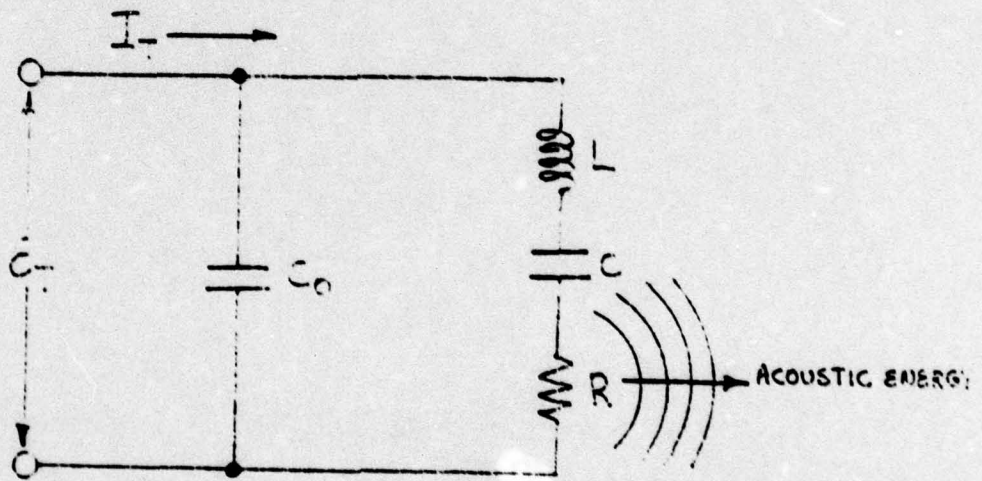

TRANSMIT MODE.

FIGURE 4.1.1-1 PIEZO-ELECTRIC TRANSDUCER EQUIVALENT CIRCUIT.

40023 B

extension tube and a hole in the sensor end-cap. Pressure integrity within the main housing is maintained by means of double 'O' ring seals between the sensor assembly and extension tube and the extension tube and the end-cap. Exposed sensor components are painted for corrosion protection and coated with an anti-foulant.

## OSCILLATOR CARD

Sound is transmitted through the water when the sensor acoustic transducers are driven by an electrical signal of appropriate frequency. This signal is generated by the "carrier oscillator" located on the oscillator card. The components making up this circuit are housed within a shield box to prevent spurious coupling to other circuits. Q1 and associated components form a Colpitts oscillator at about 1.605MHz. CR1 allows a small voltage controlled adjustment of the oscillator frequency for purposes to be described below. CR2 and CR3 provide a level dependent reduction in circuit operating "Q" and thereby establish the amplitude of the oscillator output voltage. Differential transistor pair Q2a and Q2b buffers the oscillator while facilitating signal gating. FET Q3 short circuits the buffer output when transmission is not desired. Transformer T1 is adjusted for maximum amplitude.

The "X Driver", "Y Driver", and "Z Driver" (in the case of three axis units) are formed by transistors Q9, Q11 and Q13 respectively which amplify the signal. The transistors Q10, Q12 and Q14 route the signal to any sensor axis as controlled by the timing signals. X, Y and Z (if three axis unit) sensors are time-multiplexed to eliminate cross coupling. The collectors of the drive transistors are connected to the transducer "impedance matching" networks located on the velocity interface cards.

A second crystal controlled "local oscillator" is located on the oscillator card. This oscillator comprises Q7 and associated components and is similar to the "carrier oscillator". Q8a and Q8b form a buffer. Transformer T2 is adjusted for maximum amplitude and C18 is adjusted for optimal phase locked loop performance. This oscillator operates at a constant frequency difference relative to the "carrier oscillator". To achieve this, the outputs of both oscillators are heterodyned in square-law "mixer" Q5b through one winding of each transformer T1 and T2. The "mixer" is biased by current mirror Q5a. Sum frequency outputs are rejected by "filter" R9 and C10. The remaining difference frequency signal is the input to a "saturating amplifier" I1 using positive feedback to eliminate multiple crossings. I1's output is compared to a reference frequency signal (generated on the timing card) in the "phase detector" I2. The output of I2 is a voltage proportional to the phase difference (reference frequency and difference frequency) and is used to adjust the frequency of the "carrier oscillator" to exactly 34.133 Hz lower than the frequency of the "local oscillator". Pin 1 of I2 indicates a phase locked condition. R14 and C13 act to filter this indicator and Q6 inverts this logic signal to produce "0" when the phase detector is locked. If the circuitry is working correctly, the phase detector will indicate a locked condition. The LOOP STATUS signal is used as one of status flag bits recorded on cassette tape.

A small part of the "local oscillator" signal is coupled

into the transducer "impedance matching" networks on the velocity interface circuits through "transformer" T2. This signal is summed with the acoustically received signal and is used in the mixing process on the velocity interface cards (See Section 4.1.3).

## VELOCITY INTERFACE CARDS

Each axis of the acoustic current meter uses a pair of piezo-electric transducers and a velocity interface card. The acoustic signal is generated on the oscillator card as discussed in the previous section. This signal is gated through the "impedance matching" network on the interface card by FET Q11 remaining "open". The "impedance matching" network is comprised of T1 and T2 and associated components. The X (Y) CONTROL signal gates the burst from the oscillator card either to the X or Y transducers. R3, R22 and R4 are chosen and designed to minimize phase differences between receive and transmit modes and thereby minimize measurement errors.

After each transmit burst, the sensor circuits are reconfigured for receiving. The time required for sound to travel the water path allows this transition to occur in an orderly fashion. In preparation for receiving 1) FET Q11 shorts T1 and T2 causing the transducer receive currents to flow into Q1 and Q5; 2) Q1 and Q5 are biased on; 3) Q2 turns on and Q3 turns off, connecting the amplified receive signal from one transducer to Q4; 4) Q6 turns on and Q7 turns off, connecting the amplified receive signal from the other transducer to Q8. The timing signals that accomplish this are XMT,  $\overline{\text{GATE X}}$ ,  $\overline{\text{RCVX}}$  and RCVX or the equivalent for the Y channel.

A small part of the "local oscillator" output (generated on

the oscillator card) is coupled into the transducer "impedance matching" circuit through R4 where it sums with the acoustically received signals. These two signals are amplified in composite form by Q1 and Q5 and are routed to Q4 and Q8 as described above. Q4b and Q8b act as square-law "detectors" The sum frequency components in the "detector" outputs are filtered by R8-C5 and R27-C18 and buffered by emitter followers Q9 and Q10. The buffered difference frequency signals are bandpass filtered by I2 and I1 for one channel and I10 and I9 for the other channel. The filtered outputs (TP3 and TP4) are sine waves at the difference frequency (about 34Hz). The phase difference of these sine waves is proportional to velocity and is trimmed to zero by P1 for zero water current. One of the "filter" outputs is tested on the time and temperature card to determine whether the difference frequency oscillations are present and the "yes/no" result is used as a status flag bit on the cassette tape record (one bit for X and one for Y). Transformers T3 and T4 are adjusted for maximum amplitude at TP3 and TP4. These outputs are connected to "saturating amplifiers" I3 and I6 and associated components which produce signals (TP5 and TP6) having phase and frequency like their inputs but at logic levels. Positive feedback networks R20-C11 and R39-C24 prevent spurious crossings on noise.

The phase of the acoustic burst signal from one transducer relative to the phase of the acoustic burst signal from the second transducer is directly proportional to the water velocity as discussed earlier. This phase relationship is maintained by the heterodyne

technique and can be measured in the logic signals from the saturating amplifiers I3 and I6. A "phasemeter" is comprised of CMOS logic components I4, I5, and I7. The phase difference at the outputs of I3 and I6 are converted to a variable duty level signal at TP7. This signal is +6 volts for positive phase times, 0 volts for negative phase times and is normally +3.0 volts (analog common). The duty cycle of this signal is dependent on the amount of phase difference. At exactly  $180^{\circ}$  of phase difference the duty cycle is 100% (either at +6 volts or 0 volts depending on whether the phase difference is lead or lag). This variable duty/variable level signal is the input to a 2-pole active "filter" comprising I8 and associated components. The output of this "filter" ( $V_X$  or  $V_Y$ ) is a voltage level representing one component of the velocity sensor output. The scaling is adjusted to yield  $\pm 2.0$  volts for  $\pm 180^{\circ}$  of phase difference. Note that  $180^{\circ}$  of phase difference relates to the full scale water current of 300 cm/sec. only nominally. The actual velocity represented by  $180^{\circ}$  is a function of water temperature as discussed elsewhere in this manual.

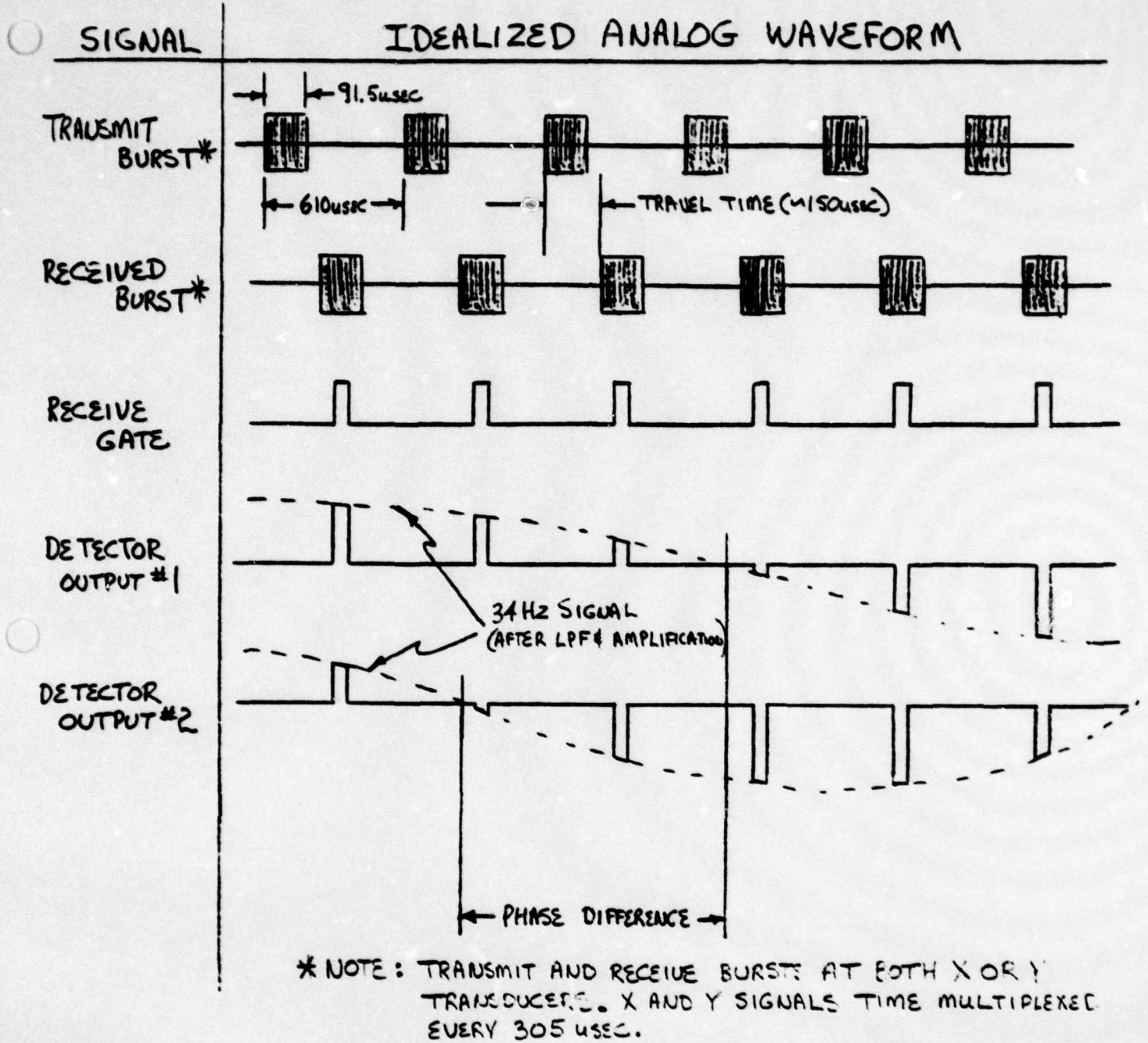

FIGURE 4.1.3-1 IDEALIZED WAVEFORMS FOR VELOCIMETER.

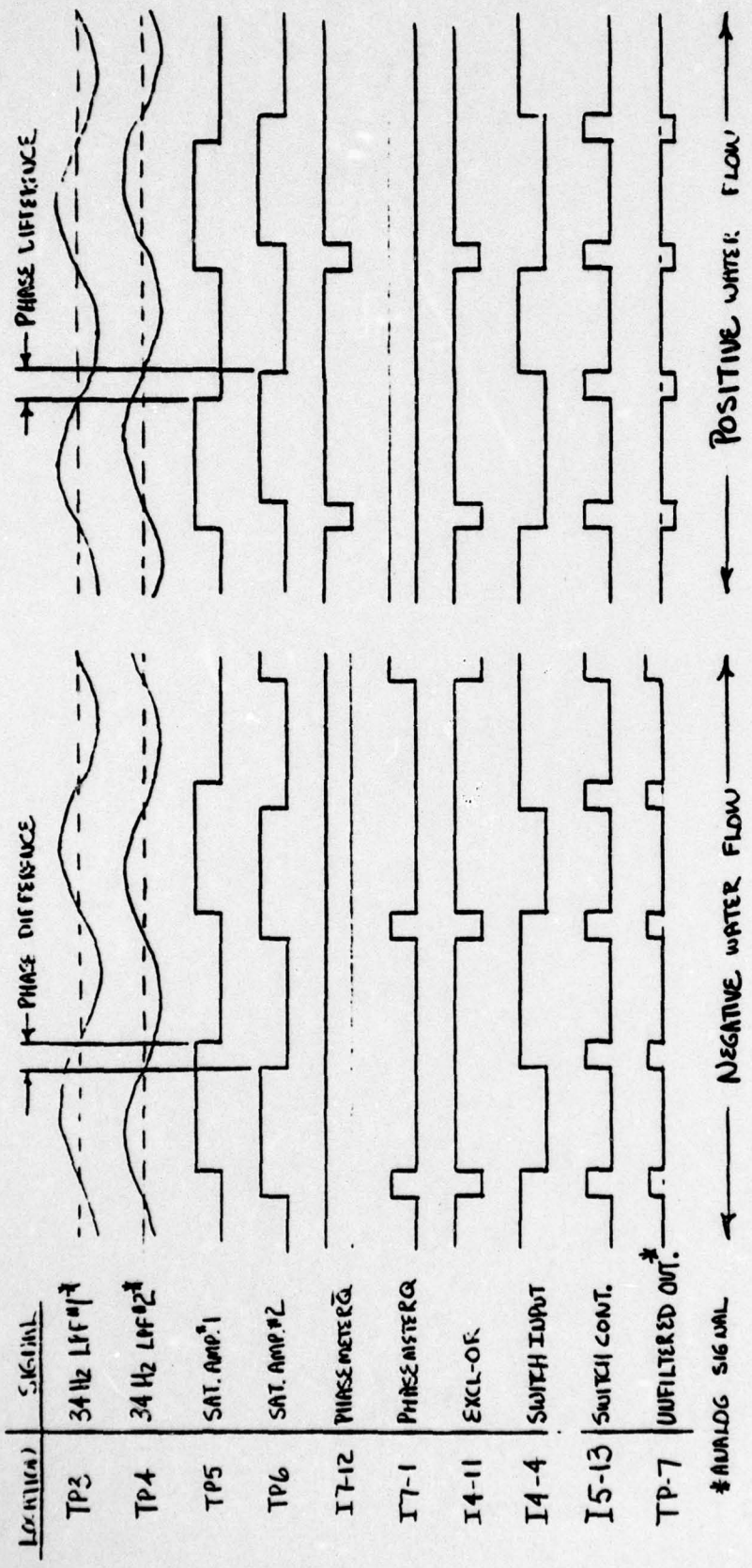

FIGURE 4.1.3-2 VELOCITY INTERFACE CARD PHASEMETER TIMING DIAGRAM

## COMPASS FUNCTION

The measurement of the orientation of the ACM-1 package to earth coordinates (North-South and East-West) is functionally blocked out in Figure 4.2-1. This function is accomplished by means of a magnetometer compass using the well known "fluxgate" principle and a compass electronics card. The compass and its electronics measure the horizontal local magnetic field as two components  $H_x$  and  $H_y$ .

$$H_x = H \quad K_m \cos \phi \quad (1)$$

$$H_y = H \quad K_m \sin \phi \quad (2)$$

where  $H$  = strength of local magnetic field in the horizontal plane (Oersteds);  $K_m$  = scaling constant (volts/Oersted);  $\phi$  = orientation of the ACM-1 package to local north; and  $H_x$  and  $H_y$  are the voltage representations of the horizontal components of local field in the package's +X and +Y compass direction respectively (see Figure 4.2-2) The compass and compass electronics are fully described in the following sub-sections.

Fig. 4.2-1

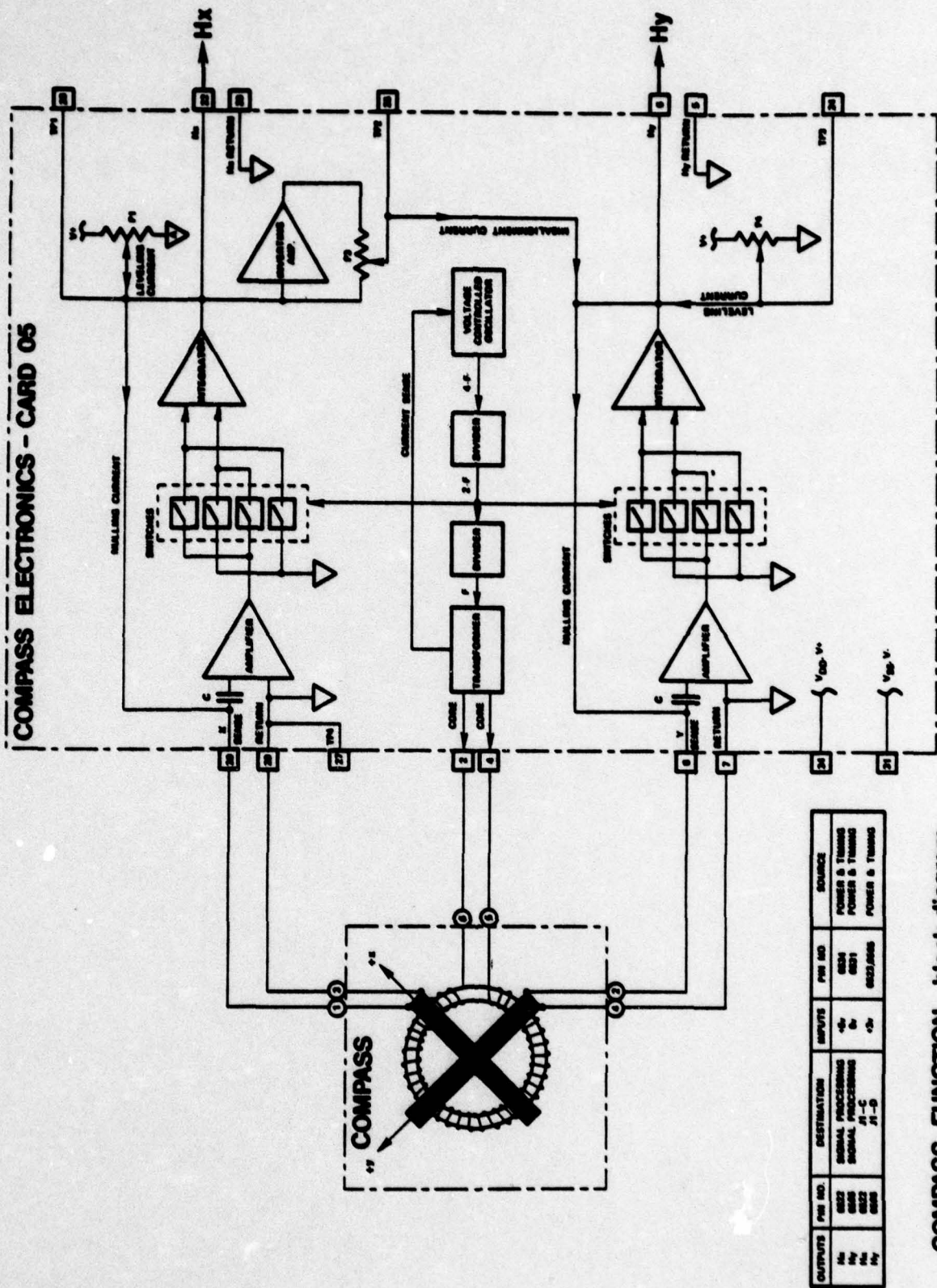

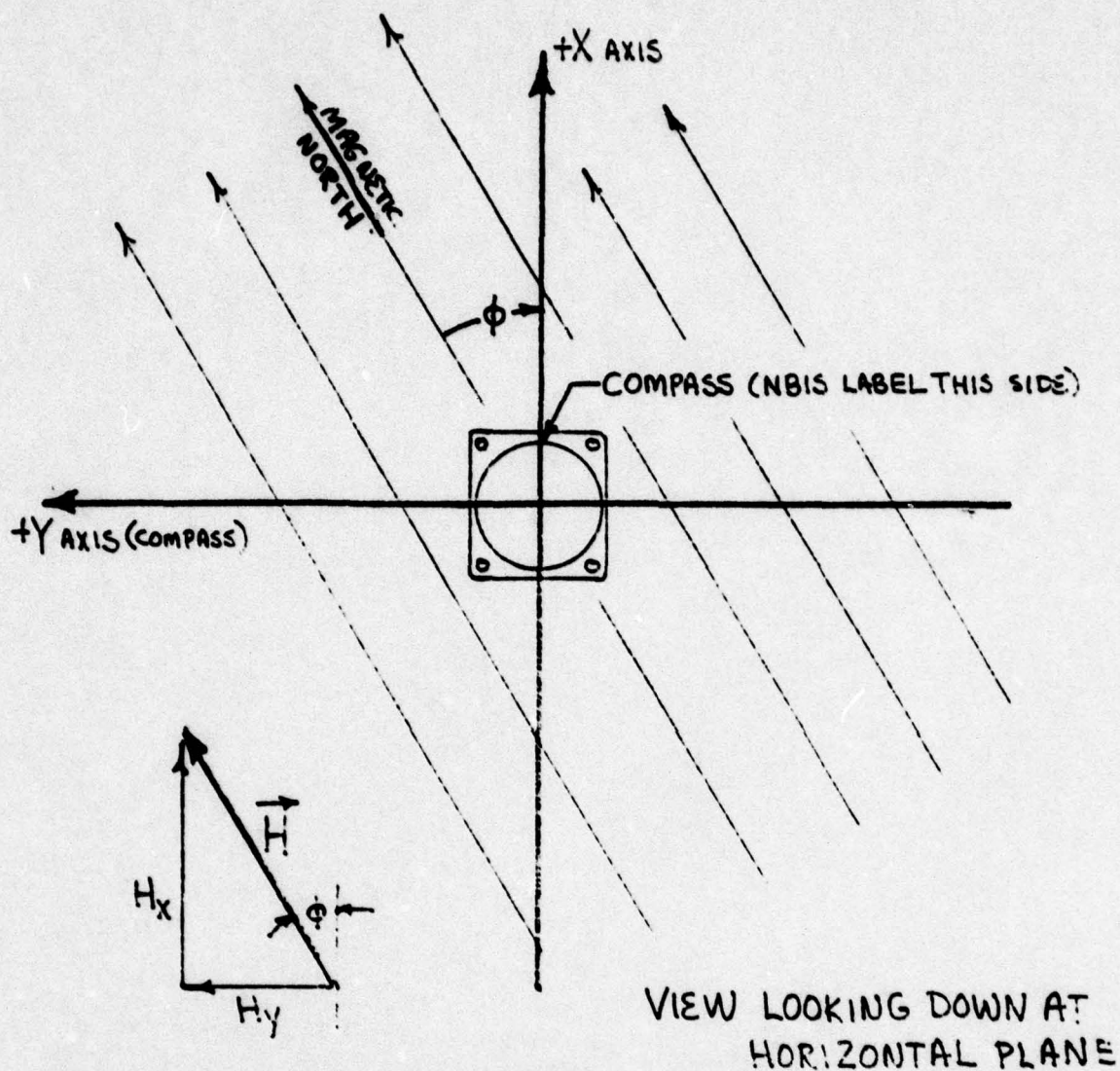

FIGURE 4.2-2 EXAMPLE ORIENTATION OF LOCAL MAGNETIC FIELD TO ACM-1 COMPASS +X AXIS AND +Y AXIS (COMPASS)

140023A

## COMPASS

The magnetometer compass sensor contains a tape wound circular core of permeable material. A torroidal winding allows the core to be driven to saturation in either direction. Two diametral windings are formed at right angles. These windings sense any imbalance in core magnetization and carry the currents necessary to null the imbalance. Leads from the three windings terminate to flexible wire and are brought out to a connector. These windings in terms of a resistance check are as follows:

Torroidal winding < 1 ohm

Sense windings =  $163 \pm 7$  ohms

The magnetometer core and its windings are fixed to a pendulous structure which is suspended from a universal joint, which is in turn suspended from the top cover of the sensor housing. The housing contains silicon fluid of the viscosity needed to damp the motions of the core/pendulum. The housing top cover is slotted to permit precise alignment of the sensor north to the +X axis of the sensor case (+X on the sensor case is identified by the NBIS markings). The sensor, as a unit, is aligned to the ACM-1 package by means of four mounting holes.

Conceptually it is easier to visualize the diametral sense windings as each being two separate windings wired in series opposition. Figure 4.2.1-1 shows this conceptualization for one diametral winding. Winding A and B as connected (and made multiple turn) would produce signal A + B which is the signal of interest. The CORE DRIVE signal produces an alternating CORE FIELD of clockwise or counterclockwise orientation. The CORE FIELD is driven to saturation in each al-

Fig. 4.2.1-1

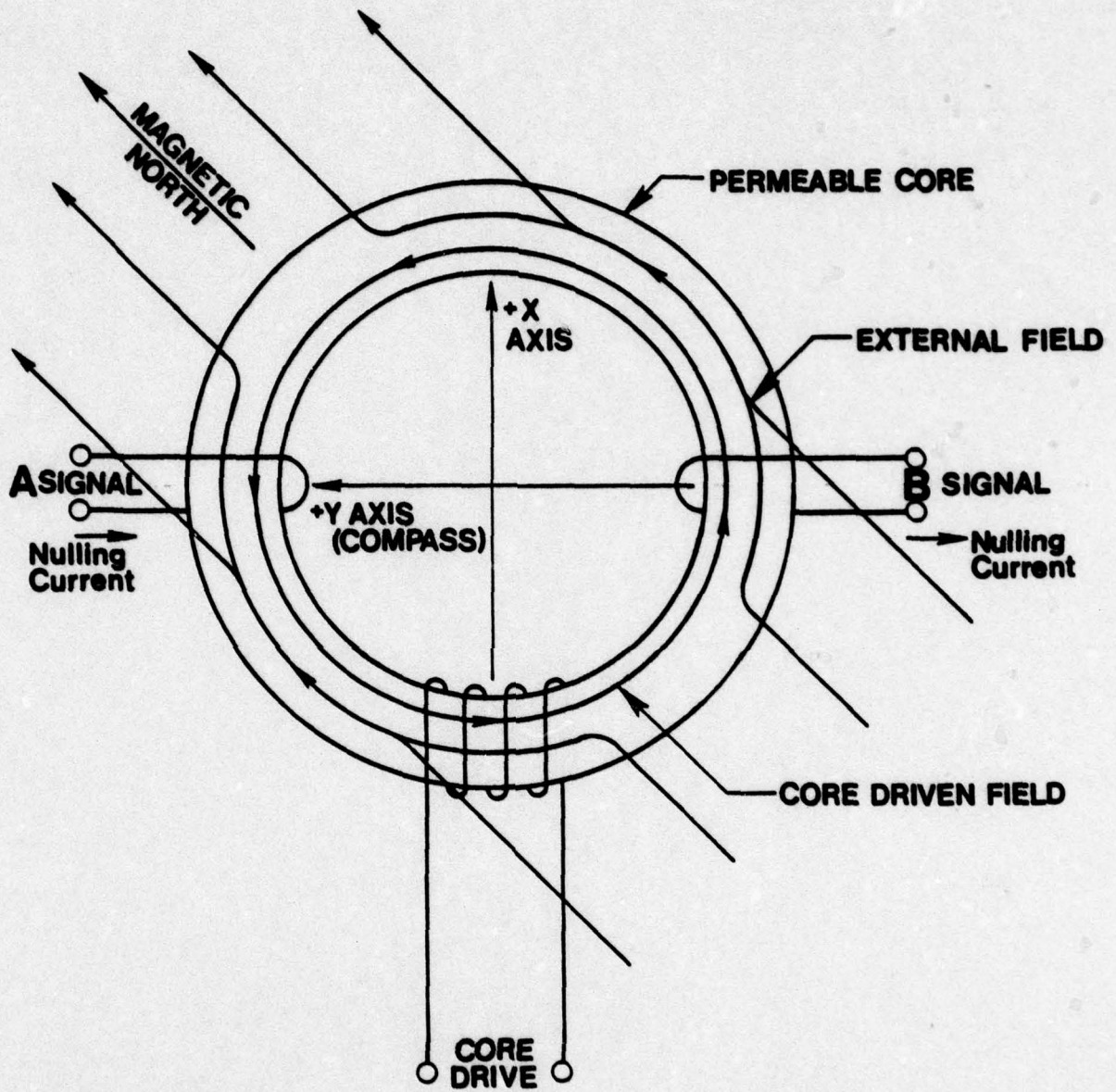

**CONCEPTUALIZED COMPASS WINDINGS (1 AXIS)**

ternating direction. Note that the for case shown in Figure 4.2.1-1, the EXTERNAL FIELD (the field to be sensed) is partly in opposition with the CORE FIELD at A and partly in compliance with the CORE FIELD at B. This condition reverses for reversed core drive. Therefore, as the core is driven to saturation, the pick-up signal at B goes to zero before the pick-up at A (the field stops changing and no voltage is induced). The electronics senses the pick-up signals and tries to maintain a nulling current through loop A and B to counteract the EXTERNAL FIELD. Note that the NULLING CURRENT required to counteract the EXTERNAL FIELD at A is the same as B (assuming uniformity of core and external field) but in the direction as shown by the arrows. This NULLING CURRENT can therefore be accomplished with the diametral windings as in the actual sensor. The amount of NULLING CURRENT is a measure of the strength of the EXTERNAL FIELD. Note that the amount of the EXTERNAL FIELD as seen at A and B is cosine related by the orientation of the EXTERNAL FIELD to the diametric orientation of the winding; when the EXTERNAL FIELD is perpendicular to the winding maximum NULLING CURRENT is required and when there is a parallel relationship zero NULLING CURRENT is required.

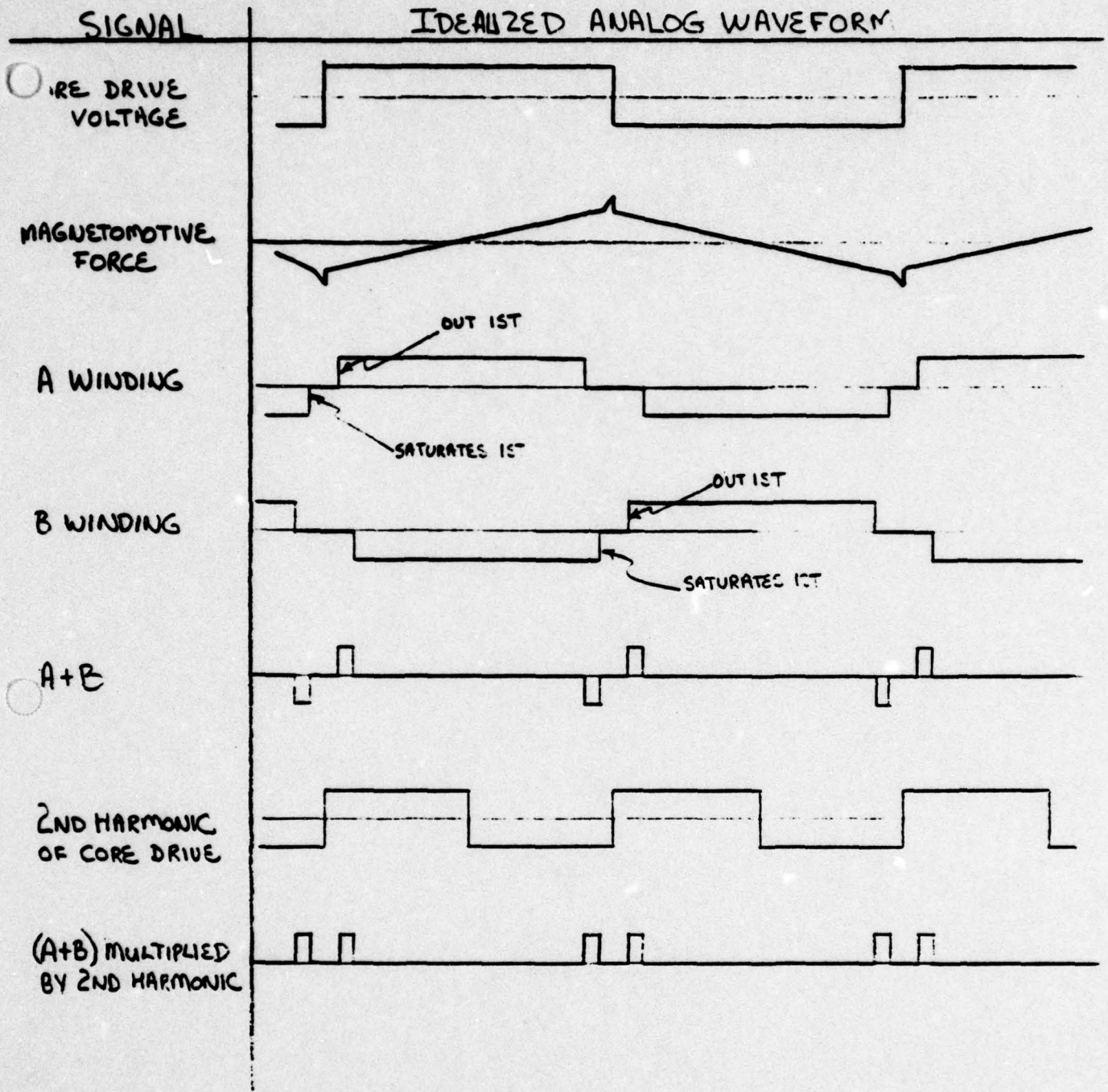

○ FIGURE 4.2.1-2 IDEALIZED WAVEFORMS FOR CONCEPTUALIZED COMPASS WINDINGS.

## COMPASS ELECTRONICS CARD

A voltage square wave drives the magnetometer core toroidal winding. The core flux rises progressively toward saturation when the drive voltage is positive, then reverses direction (and rises toward saturation in the opposite direction) when the drive voltage is negative. The current through transformer T1 is sensed by R30. Current corresponding to core saturation causes Q5 to conduct. This increases the output frequency of the core drive from the "voltage controlled oscillator" I6 through "dividers" I7. A balance is reached which provides optimum core saturation.

The sense electronics for  $H_x$  is described below. Operation of  $H_y$  sense electronics is analogous. The sense winding output is A.C. coupled and is amplified by Q1, Q2 and associated components. The resulting signal is the input to four CMOS analog switches I2 which are controlled by twice-drive frequency output of "divider" I7. The switch is configured to generate a differential output voltage in the presence of inputs at twice the drive frequency. During the first and third quarters of the drive cycle the amplified sense winding output is switched to the non-inverting input of differential integrator I1 and during the second and fourth quarters of the drive cycle the amplified sense winding output is switched to the inverting input of the differential integrator I1. Signal common is switched to the inverting input in the first case and to the non-inverting input in the second case. Differential "integrator" I1 smoothes this voltage and causes a current to flow through R9 and P2 and the core sense

winding. The magnitude of this current is proportional to the strength of the horizontal external field component perpendicular to diametric orientation of the winding. The voltage output  $H_x$  is also proportional to the field component. Potentiometer P2 provides scale adjustment and P1 provides adjustment of a small current used to compensate for the effects of imperfect leveling of the magnetometer core.

$H_x$  output is connected to inverting amplifier I3. P3 bridges this amplifier so that any portion  $+H_x$  to  $-H_x$  is available. The adjustment of P3 is chosen to drive a current through R15 into the Y axis sense coil precisely compensating for angular misalignments of the sense windings.

## SIGNAL PROCESSING FUNCTION

The analog voltages from the compass and its electronics and the velocity sensor and its electronics are the four voltages  $H_x$  and  $H_y$  and  $V_x$  and  $V_y$ .  $H_x$  and  $H_y$  represent the horizontal projection of the strength of the local magnetic field in the +X and +Y compass axes respectively;  $V_x$  and  $V_y$  represent the water current velocity components in the +X and +Y current axes in the plane perpendicular to the instrument axis (i.e. the horizontal for no tilt). The +X, and +Y compass and +Y current axes are defined in terms of the instrument housing. These four signals  $H_x$ ,  $H_y$ ,  $V_x$  and  $V_y$  are used to derive the velocity components with respect to earth coordinates, namely  $V_N$  (North-South component) and  $V_E$  (East-West component). Mathematically this is simply a coordinate rotation and can be expressed as follows:

$$\gamma = \tan^{-1} \left( \frac{V_y}{V_x} \right) \quad (1)$$

$$\phi = \tan^{-1} \left( \frac{H_y}{H_x} \right) \quad (2)$$

$$V_N = \cos(\gamma + \phi) * (V_y^2 + V_x^2)^{1/2} \quad (3)$$

$$V_E = \sin(\gamma + \phi) * (V_y^2 + V_x^2)^{1/2} \quad (4)$$

where  $\phi$  is the angle between magnetic North (magnetic field vector) and the reference +X axis of the current meter and  $\gamma$  is the angle between the reference axis and the current vector (refer to Figure 4.3-2). The analog implementation of this coordinate rotation is accomplished by the signal processing card and is fully discussed in the following sub-sections. Note that the scaling constant of Oersted to

volts and cm/sec to volts is normally left out of the equations.

The analog-to-digital cards (A/D card) convert  $V_N$  and  $V_E$  to a series of digital pulses that are continuously accumulated by the accumulating card, thus yielding a true vector average of current flow. The two A/D cards are also discussed in the following sub-sections. These functions are block-out in Figure 4.3-1.

Fig. 4.3-1

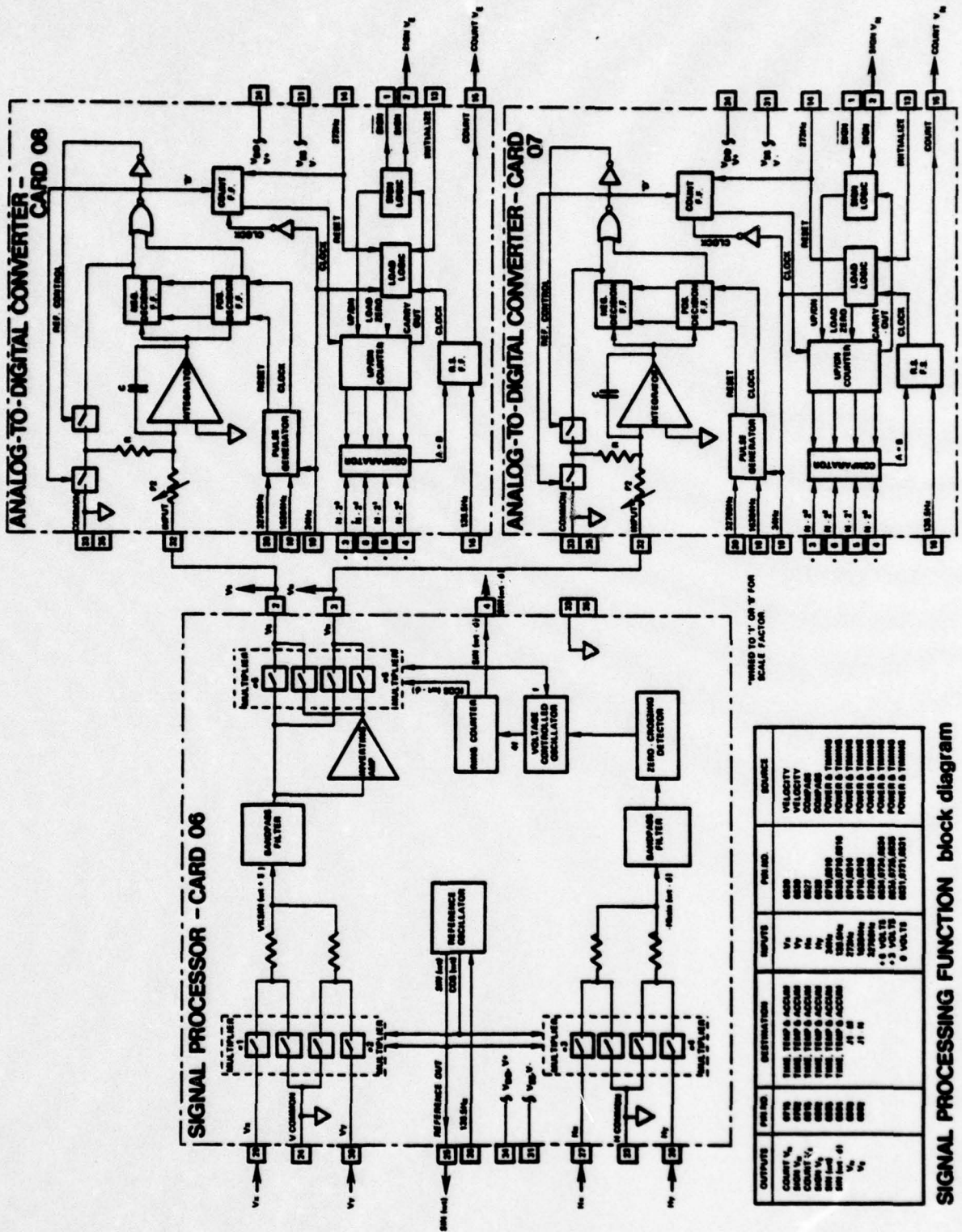

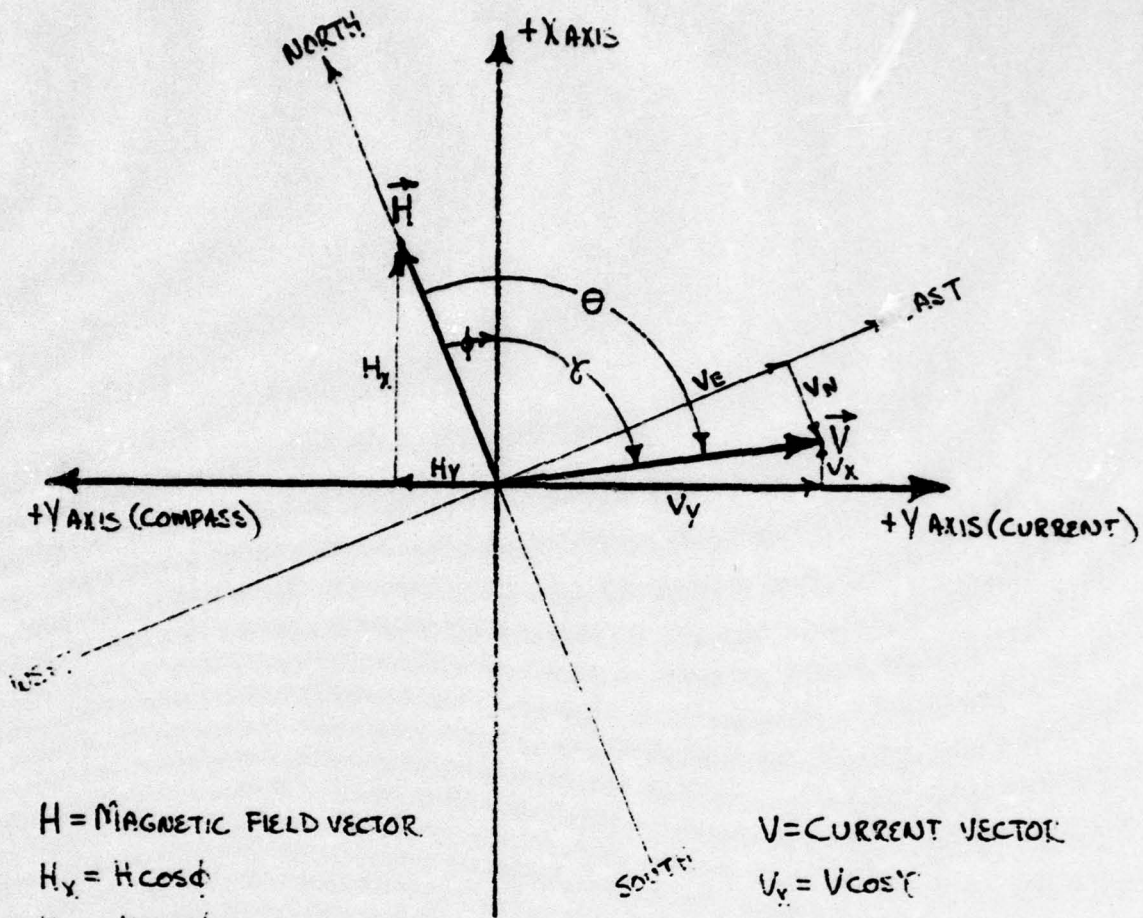

$H$  = MAGNETIC FIELD VECTOR

$$H_x = H \cos \phi$$

$$H_y = H \sin \phi$$

$$\phi = \tan^{-1} \left( \frac{H_y}{H_x} \right)$$

$$H = (H_x^2 + H_y^2)^{1/2}$$

$V$  = CURRENT VECTOR

$$V_x = V \cos \gamma$$

$$V_y = V \sin \gamma$$

$$\gamma = \tan^{-1} \left( \frac{V_y}{V_x} \right)$$

$$V = (V_x^2 + V_y^2)^{1/2}$$

$$\theta = \phi + \gamma$$

$$V_N = V \cos \theta$$

$$V_E = V \sin \theta$$

FIGURE 4.3-2 COMPASS AND CURRENT SENSOR COORDINATES

## SIGNAL PROCESSOR CARD

The purpose of the signal processor card is to convert  $H_x$ ,  $H_y$ ,  $V_x$  and  $V_y$  outputs of the compass and velocity sensor and electronics to North-South and East-West components of velocity so that vector averaging can be performed correctly. The definitions of the components are as follows:

$$H_x = H \cos \phi \quad (1)$$

$$H_y = H \sin \phi \quad (2)$$

$$V_x = V \cos \gamma \quad (3)$$

$$V_y = V \sin \gamma \quad (4)$$

where  $H$  is the scaled magnitude of the magnetic field,  $V$  is the scaled magnitude of current velocity, and  $\phi$  and  $\gamma$  are the vector orientations ( $\phi$  being the +X axis orientation referred to magnetic North and  $\gamma$  being the current direction referred to the +X axis where positive angles increase clockwise from the referenced axis or vector). See Figure 4.3-2 for coordinate definition.

The theory of operation for the signal processor card is described below referring to Figure 4.3-1 the functional block diagram. "Multiplier" output number one can be described by equation (5). The "reference oscillator" has amplitude  $K$  and angular frequency  $\omega$  (radians/second).

$$E_1 = V_x K \sin(\omega t) \quad (5)$$

$$E_1 = VK \cos \gamma \sin(\omega t)$$

Applying trigonometric relationships to equation (5) produces equation (6).

$$E_1 = \frac{VK}{2} [\sin(\omega t + \gamma) + \sin(\omega t - \gamma)] \quad (6)$$

And similarly the output of "multiplier" number two is given by equation (7).

$$E_2 = \frac{VK}{2} [\sin(\omega t + \gamma) - \sin(\omega t - \gamma)] \quad (7)$$

The result of adding  $E_1$  and  $E_2$  is shown by equation (8).

$$E_{1+2} = VK \sin(\omega t + \gamma) \quad (8)$$

The signal  $E_{1+2}$  is in other words an AC signal exactly proportional to current magnitude and having a phase angle  $\gamma$  with respect to the "reference oscillator". Similarly equations (9), (10) and (11) describe "multipliers" three and four and their sum.

$$E_3 = \frac{-HK}{2} [\sin(\omega t + \phi) + \sin(\omega t - \phi)] \quad (9)$$

$$E_4 = \frac{HK}{2} [\sin(\omega t + \phi) - \sin(\omega t - \phi)] \quad (10)$$

$$E_{3+4} = -HK \sin(\omega t - \phi) \quad (11)$$

The angle  $\theta$  between the current vector and magnetic North (positive clockwise referred to North) is given by equation (12).

$$\theta = \gamma + \phi \quad (12)$$

The output of multiplier number five formed by the product of  $E_{1+2}$ , equation (8), and  $E_{3+4}$  shifted by  $90^\circ$  is given by equation (13).

$$E_5 = VK \sin(\omega t + \gamma) * -HK \sin(\omega t - \phi - 90^\circ)$$

$$E_5 = VHK^2 \sin(\omega t + \gamma) \cos(\omega t - \phi)$$

$$E_5 = \frac{VHK^2}{2} \sin(\gamma + \phi) + \frac{VHK^2}{2} \sin(2\omega t + \gamma - \phi) \quad (13)$$

The output of multiplier number six formed by the product of  $-E_{1+2}$ , equation (8), and  $E_{3+4}$  is given by equation (14).

$$E_6 = -VK \sin(\omega t + \gamma) * -HK \sin(\omega t - \phi)$$

$$E_6 = VHK^2 \sin(\omega t + \gamma) \sin(\omega t - \phi)$$

$$E_6 = \frac{VHK^2}{2} \cos(\gamma + \phi) - \frac{VHK^2}{2} \cos(2\omega t + \gamma - \phi) \quad (14)$$

The second term in both equation (13 and (14) is an AC term that can be removed by a lowpass filter. The first terms are the required signals  $V_E$  and  $V_N$  respectively as long as the factor  $HK^2/2$  can be made to be unity. The practical implementation of the above theory is described below.

Constant amplitude square waves of radian frequency ' $\omega$ ' are used in place of  $\sin(\omega t)$  and  $\cos(\omega t)$  thus permitting the use of simple transmission gates as "multipliers". The "reference oscillator" is formed from the flip-flop network of I3 clocked by a 136.5 Hz signal (generated on the timing and power card). This forms a 34 Hz square-wave with outputs in phase with  $\pm \sin(\omega t)$  and  $\pm \cos(\omega t)$ . This square-wave drives "multipliers" one and two (I1) and "multipliers" three and four (I2). The high frequency components caused by using the square-wave "multiplier" are removed by the summing "bandpass filter" I4 and I6 for the velocity channel and I5 and I7 for the compass channel. I8 is used as an "inverter" for the  $\sin(\omega t + \gamma)$  term. Quadrature components of the compass channel are formed by "zero-crossing detector" I9; phase-locked loop "voltage controlled oscillator" I12; and "ring counter" network I11. These quadrature components are square-wave constant amplitude signals that allow "multiplier" number five and six to be simple transmission gates (I10). Note that the magnitude of the magnetic vector is not of importance since the quadrature terms are always used as on/off signals for the transmission gates. Note that the output of the phase-locked loop "oscillator" is a signal four times the lock-on

frequency; the signals to be locked together are the zero-crossing detector output (the  $\sin(\omega t - \phi)$  term) and the divide by four output of the "ring counter". Potentiometer P2 is adjusted to give a 50% duty cycle signal at the output of the "zero-crossing detector" and P3 is adjusted to correct any phase errors.

The signal processor card is set up to produce a  $V_E$  and  $V_N$  signal with a DC component of +1.0 volt nominal fullscale for +2.0 volt nominal fullscale velocity input. The output scaling is adjusted via potentiometer P4. Note that the actual outputs of the signal processor card are DC levels equal to  $V_E$  and  $V_N$  with a large AC component (especially at 68 Hz).

A 1 megohm resistor is connected from the  $H_x$  to V+ on the compass connector. This has the effect of forcing the compass input to the resolver to look like a due North orientation when the compass card is removed. The resistor has no effect when the compass card is installed.

One of the data words recorded on cassette tape is derived from the signals of I3,  $\sin(\omega t)$ , and I11,  $\sin(\omega t - \phi)$ . On the time and temperature card, the angle  $\phi$  is resolved and represents the heading of the instrument +X reference axis in the traditional compass sense where  $0^\circ = \text{North}$ ,  $90^\circ = \text{East}$ ,  $180^\circ = \text{South}$  and  $270^\circ = \text{West}$ .

## ANALOG-TO-DIGITAL CONVERTER CARD

The two analog-to-digital converter cards (A/D cards) in the ACM-1 receive as respective inputs the signals  $V_N$  and  $V_E$  from the signal processor card. Recall that both  $V_N$  and  $V_E$  signals have DC components equal to  $V\cos\theta$  and  $V\sin\theta$  respectively scaled for 1.0 volt fullscale (nominal), where  $V$  is the scaled water current vector magnitude and  $\theta$  is the angle between the current vector and magnetic North (positive clockwise referred from North); and  $V_N$  and  $V_E$  signals have large AC components especially at 68 Hz. Further recall that  $V_N$  and  $V_E$  are the voltage representations of water current components in the North-South and East-West directions and are the signals required to accomplish true vector averaging representative of net flow.

$V_N$  and  $V_E$  signals are inputs to identical circuits on separate cards. These voltages are each converted to currents by  $R1$  (trimmed by the scale adjust potentiometer  $P2$ ) into the summing point of operational amplifier  $I1$  and associated components.  $I1$  is configured as an "integrator". Note that jumper  $J1$  is installed shorting out  $C3$  and allowing  $C1$  to be the integrating capacitor thereby lengthening the integrator time constant only after the zero point has been adjusted by  $P1$ . An input current from a negative voltage will cause  $I1$ 's output to become increasingly positive (with respect to analog common of +3 volts) and conversely an input current from a positive voltage will cause  $I1$ 's output to become increasingly negative. At a certain positive level  $Q1$  and  $Q3$  will conduct causing the 'D' input

of "decision flip-flop" I3 (pin 5) to be a logic '1' and likewise at a certain negative level Q2 and Q4 will conduct causing the 'D' input of "decision flip-flop" I3 (pin 9) to be logic '0'. I3 is continuously clocked at 34 Hz through the "pulse generator" circuit of I6. I6 produces a narrow reset/set pulse followed by a narrow clock pulse at 34 Hz duty cycle by means of reset clocks at 32768 Hz and 16384 Hz. I3 is used to make a decision about the state of the integrator output (positive or negative level) at a 34 Hz rate.

The positive/negative "decision flip-flops" of I3 are used to control transmission gates formed by I2. After a positive/negative decision is made, I2 (pin 12 and 13) switches either 0 volts or +6 volts to the integrator summing junction through R3 counteracting and reversing the effects of the signal input on the integrator. Note that during the narrow decision making time, I2 (pin 5 and 6) switches +3 volts (analog common) to the integrator summing junction. Also note that the CMOS regulated supply voltages are used as conversion references. These same supply voltages are used on the transducer interface cards to generate  $V_x$  and  $V_y$ . The result is a ratiometric conversion unaffected by small reference level variations.

Each time this decision process occurs, a count-down or count-up command is transmitted to binary "up/down" counter" I11, through "count flip-flop" I7 (pin 5). I7 (pin 5) is clocked at the halfway point in the 34 Hz cycle and cleared a short time later by

the 273 Hz clock. Counter I11 is connected to "comparator" I12. The maximum count corresponding to the scaling factor appears as the other four bits of the comparator (connector pins 4,5,6 and 3). This maximum count corresponds to the averaging interval in minutes. Pulses out of the A/D card (connector pin 15) occur only after a time directly related to the averaging interval. In this manner, the scale factors are maintained regardless of the averaging interval. Returning to the "comparator" I12, when the "up/down counter" output equals the scale factor, the A=B output of the "comparator" goes low setting the "R-S flip-flop" formed by I5 (R13 and C2 delay the pulse). The counter counts up or down depending on both the SIGN and the current decision. Output COUNT pulses occur only after I11 reaches fullscale (A=B at comparator) indicating a count to be accumulated in the negative or positive sense. The "R-S flip-flop" is cleared by the next 136.5 Hz high level and one COUNT pulse is sent out on connector pin 15. For fullscale input signals ( $V_N$  or  $V_E$ ), the count output rate will be at 34 Hz for scale factor of 1 count and  $34/N$  Hz for other scale factors ( $N=1$  to 15). For less than full-scale input, the count output rate will be less and may be mixed with counts with the opposite sign indication.

The setting of "R-S flip-flop" I5 clocks the "load logic", I10 (pin 3) which in turn causes the next 34 Hz edge to clock I7 (pin 7). This I7 flip-flop is reset shortly later by the 273 Hz clock. The output of I7 (pin 13) resets flip-flop I10 (pin 4) and sets the "sign flip-flop" I10 (pin 10) to a positive sign indication.

The "sign flip-flop" is set minus if the "decision flip-flops", I3, indicate negative on the next 34 Hz edge. This is accomplished by counter I11 set in a count-down state and being parallel loaded with zero which causes the CARRY-OUT to go low, gating through the 34 Hz. The "sign flip-flop" output is used on the accumulator card and also in combination with exclusive-or gate I4 (pin 11) to direct the counter I11. The exclusive-or combination of the SIGN and the negative "decision flip-flop" I3 (pin 2) cause counter I11 to count up or down dependent on whether the input signal is negative decreasing, negative increasing, positive decreasing or positive increasing.

Basically what occurs on this card is that counts are sent out on connector pin 15 at a rate proportional to the magnitude of the input signal ( $V_N$  or  $V_E$ ) and the scaling factor (connector pins 4, 5, 6 and 3) along with an indication (SIGN) of whether the counts are meant to increase or decrease the accumulating result. On the accumulator card, these counts are accumulated for a fixed amount of time (proportional to the scale factor) the result being a true vector average of the water current flow.

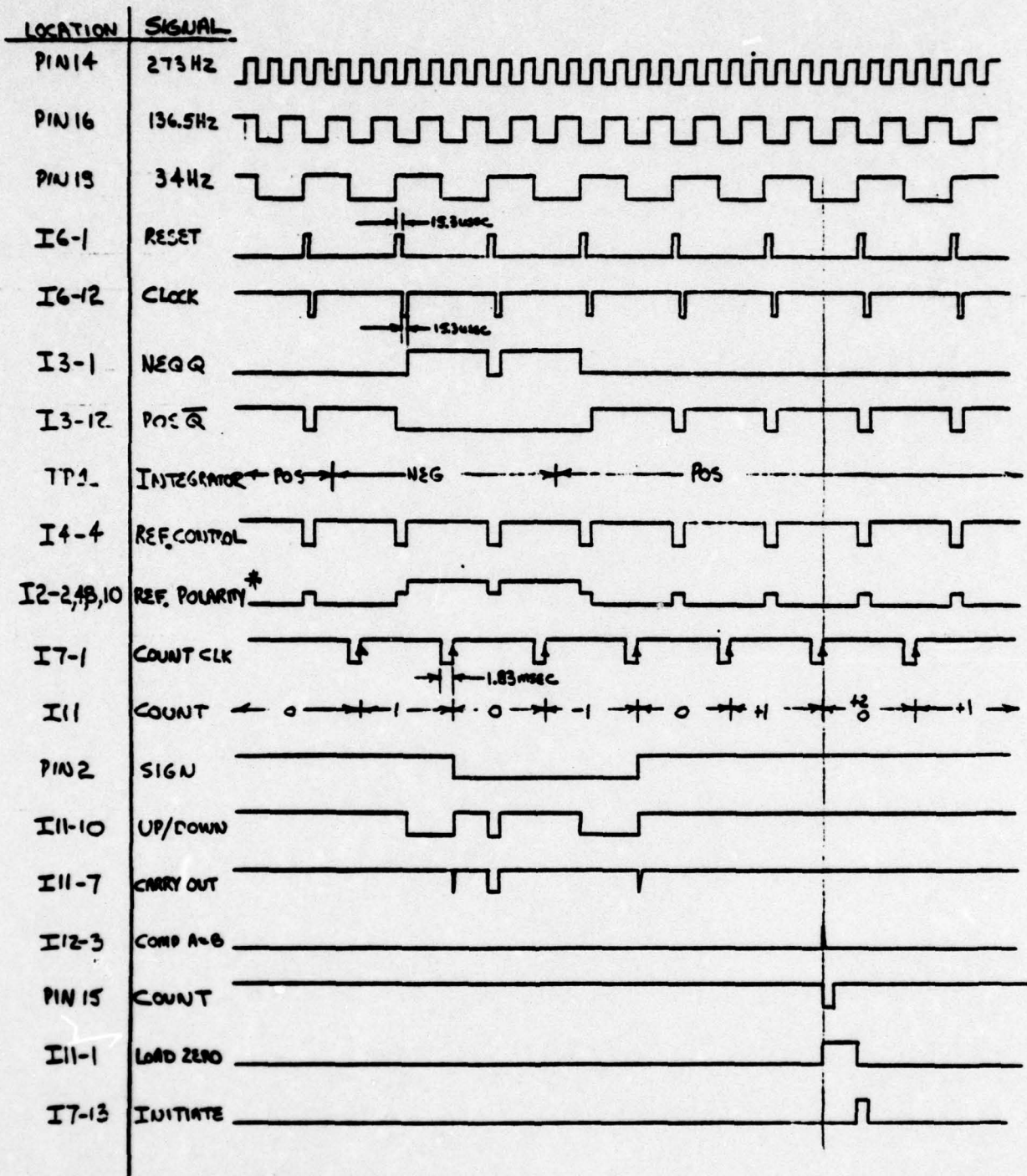

\* NOTE: ANALOG SIGNAL AT +6, +3 OR 0 VOLTS

FIGURE 4.3.2-1 ANALOG-TO-DIGITAL CONVERTER CARD TIMING DIAGRAM (SCALE FACTOR = 2 COUNTS)

## POWER AND TIMING FUNCTION

In the standard configuration, the ACM-1 operates from battery power. This battery pack is mounted at the top of the card rack. Power for the cassette motor drive is provided directly from the battery for the Sea Data recorder version and through a switched DC/DC converter (located on the formatter card) in the case of the Memodyne recorder version. The power and timing card switches and fuses the battery +8 battery voltage and regulates it to the +6 volts and +3.0 volts used in the rest of the electronics. Timing signals are also generated on this card. This function is blocked out in Figure 4.4-1. A detailed discussion of the battery and the power and timing card follows.

Fig. 4.4-1

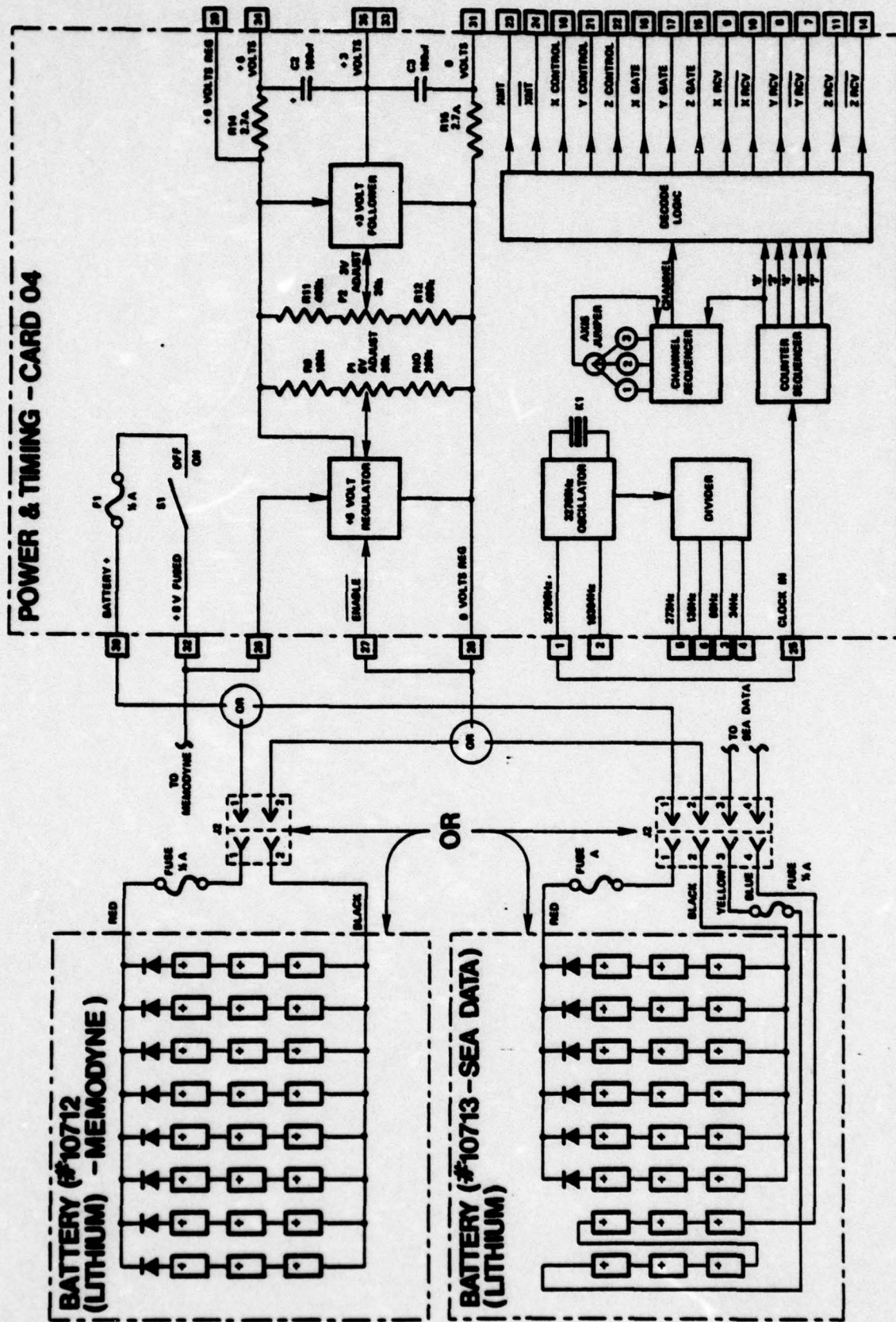

NOTE: POWER AND TIMING OUTPUTS USED ON ALL CARDS. NO INPUTS TO THIS FUNCTION.

POWER & TIMING FUNCTION block diagram

The lithium cells are especially packaged for Neil Brown Instrument Systems in the 24 cell packages. Diodes for parallel banks of cells are included and internal fuses or inline fuses may or may not be included.

The following safety guidelines must be adhered to when using lithium cells:

- DO NOT SUBJECT BATTERIES TO EXCESSIVE DRAIN
- DO NOT SHORT OUTPUT
- DO NOT CHARGE BATTERIES OR USE IN CONJUNCTION WITH OTHER POWER SOURCES
- DO NOT USE WITHOUT FUSING
- DO NOT DISPOSE OF IN FIRE
- OBSERVE CORRECT POLARITY
- DO NOT DISASSEMBLE

Lithium cells are extremely safe if used correctly but because of the danger if misused (i.e. shipped with loose wires allowing possible shorting) they must be transported in the United States according to certain regulations as described in the Appendix of this manual.

### BATTERY PACK

The battery pack is comprised of 24 "D" sized lithium cells hermetically sealed in a plastic or metal case. Two versions of the battery pack are used: 1) Neil Brown Instrument Systems No. 10713 with the Sea Data recorder and 2) Neil Brown Instrument Systems No. 10712 with the Memodyne recorder. The Sea Data version has 6 cells wired in series for +16 volts nominal and 18 cells wired as 6 parallel sets of 3 cells in series for +8 volts nominal. The Memodyne version has 8 sets of 3 cells in series for +8 volts nominal.

NBIS No.	Use	WIRE CODE			
		+8 Volts	Common	+16 Volts	Common
10713	Sea Data Recorder	Red	Black	Yellow	Blue
10712	Memodyne	Red	Black	-	-

Lithium cells are a high energy density power source well suited for oceanographic instrumentation. Some of their features are 1) high cell voltage of about 2.8 volt nominal; 2) flat discharge characteristics; 3) excellent low temperature performance (less than 10% decrease in capacity at 0°C) and 4) excellent shelf-life (10 years to 75% capacity). The primary lithium battery is a lithium sulfur dioxide system consisting of a lithium foil anode, carbon based cathode, separator, and sulfur dioxide rich organic electrolyte. The cells are constructed in a cylindrical steel housing and are hermetically sealed. Because the lithium battery contains pressurized contents, the cells are designed with a safety vent (which opens between 230° and 250°F).

## POWER AND TIMING CARD

The battery voltage of +8 volts nominal is routed directly through fuse F1 and switch S1 on the power and timing card. The backplane connector jumper of pin 32 to 26 can be used by replacing it with an ammeter to check current drain in the +8 volts section of the battery pack. An alternative method is to connect the ammeter between pin 32 and 30 of the power and timing card with switch S1 in the "off" state.

$$\text{Current (recorder off)} = 5.0\text{ma} \pm 0.5\text{ma} \\ (+0.3\text{ma if tilted} > 30^\circ)$$

$$\text{Current (Memodyne recorder on)} < 270\text{ma} \pm 50 \text{ ma}$$

Note that the Sea Data recorder uses the +16 volts battery output directly and that this voltage is fused inline and not routed through the power and timing card.

The +6 volt regulator is formed by Q1a and Q1b acting as a current mirror and supplying current to reference diode D1. This current, as well as the biasing current to I2 is available only when ENABLE is connected to the battery return. This high resistance connection allows remote control of the meter's "on/off" status (for the standard ACM-1, this control is permanently tied low). I2 and Q2 form a linear series pass regulator which when adjusted by P1 regulates pin 29 at  $+6.000 \pm .001$  volts. I1 is a follower which is adjusted by P2 to establish  $+3.000 \pm .001$  volts at pin 33 and 35. R15-C3 and R14-C2 are filters which supply and isolate circuits sections not requiring extremely stable voltages.

The timing signals needed for operation of the ACM-1 circuitry are also generated on this card. The waveforms generated are illustrated on Figure 4.4.2-1. The timing signals are derived from a CMOS crystal "Oscillator" (crystal K1 and associated components) and pulse shaper (part of I11). The 32768Hz clock output of I11 is connected via the backplane to the "counter sequencer". Divider I11 also produces a divided by two output at 16384 Hz. Pins 6 of I11 is the divide by 6 circuitry of I11 producing a 546.133 Hz clock. This clock in turn feeds I10, a binary "divider", producing clocks 273.066 Hz, 136.533 Hz, 68.266 Hz and 34.133 Hz. The 34.133 Hz clock (normally called 34 Hz) is used by the oscillator card to provide the difference frequency reference. This 34 Hz clock is also used to derive the 1 minute clock on the time and temperature card.

The "counter sequencer" is fed by the 32768 Hz clock via pin 25 and comprises I3, I8, I7 and I4. I3 is a decade counter with ten decoded outputs that sequence the timing operation. I7 forms the "channel sequencer" where jumper J1 is set for 1, 2 or 3 axis (2 axis for the standard ACM-1). The remaining "decode logic" circuits I6, I9 and I5, decode the sequence steps and produce the required timing signals. XMT occurs during "0", "1" and "2" (sound is transmitted); GATE begins at "4" and remains through "6" (transducer receive amplifier "on"); during "6" the RCV signal is on (received signal gated through mixer/filter); and after "9" the sequence begins again but for the next axis in the sequence.

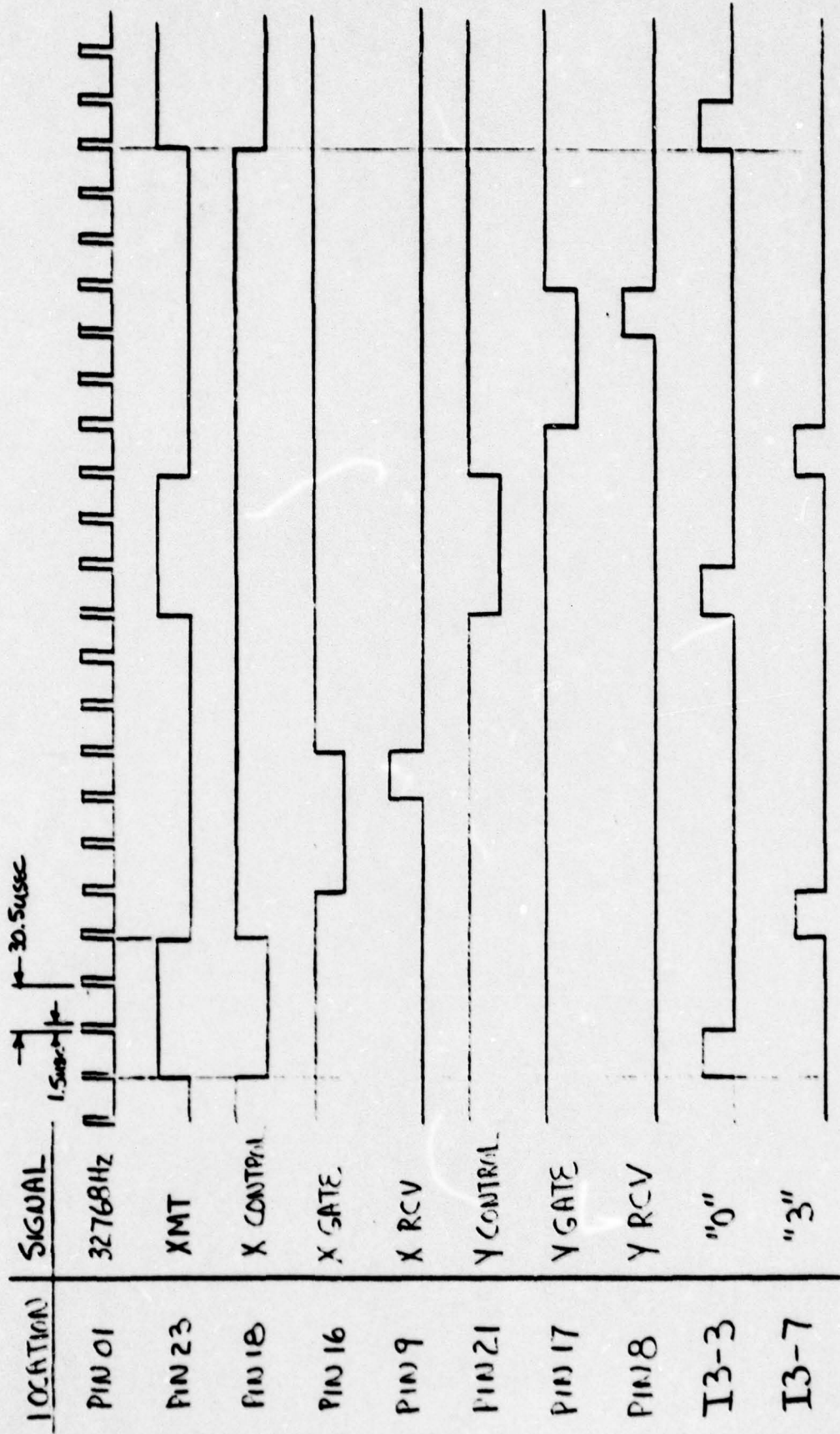

FIGURE 4.4.2-1 POWER AND TIMING CARD TIMING DIAGRAM

## TIME, TEMPERATURE AND ACCUMULATING FUNCTION

The time, temperature and accumulating function basically includes the operation of storing the current velocities, temperature, compass heading, status, and header in serial shift registers until ten sets of continuously averaged water current components are stored. After ten times N minutes (N being the jumper selectable number of minutes per average) the formatter/recorder records the data record on cassette tape. COUNT pulses and SIGN signals from the A/D card represent the instantaneous water current components which are continuously accumulated. A thermistor and its electronics generate a temperature word. Compass signals from the signal processor card and various status signals also are used as input data. Time is generated as a binary count of minutes derived from the 34.133 Hz clock. This function is blocked out in Figure 4.5-1 and each card is fully described in the following sub-sections.



## ACCUMULATOR CARD

The outputs of the analog-to-digital converter cards for  $V_N$  and  $V_E$  are the signals called COUNT  $V_N$ , SIGN  $V_N$ , COUNT  $V_E$  and SIGN  $V_E$ . Recall that these signals represent the water current components in geomagnetic coordinates where the rate of counts and sign are directly related to the magnitude and sign of water current components. Further recall that by accumulating these counts (i.e. counting in an up/down counter) for the averaging interval the final count will represent the scaled component magnitude.

The binary up/down counters I10, I9 and I7 accumulate the COUNT  $V_E$  pulses as directed up or down by SIGN  $V_E$  and counters I6, I4 and I3 accumulate the equivalent for  $V_N$ . "Down-counter" I16, once loaded with the number of minutes in the averaging interval (1 to 15 equal to the A/D scale factor), counts as clocked by the MINUTE clock. At count zero, ZERO DETECT (I16 pin I4) causes "R-S flip-flop I13 to be set; this loads count 24 in "shift counter", I12, and gates on the shift clock "oscillator" formed from I13 and associated components. At the setting of "R-S flip-flop" I13, a LOAD pulse is generated through C1-R1 at the rising edge. This LOAD pulse loads the accumulated water components (in I10, I9 and I7 for  $V_E$  and I6, I4 and I3 for  $V_N$ ) into serial "shift registers" I11, I8 and I5. At the same time, the "scan counter" I15 is clocked. The twenty four bits of velocity data are then serially shifted into "shift registers" I1 and I2 by means of the shift clock pulses. The clocks also count down "shift counter" I12 (which was loaded with 24); after

the 24th clock, the ZERO DETECT line goes low and "R-S flip-flop" I13 is reset which disables the shift clock "oscillator". The completion of this shift process causes the "accumulating counters" for  $V_E$  and  $V_N$  to be loaded with 1000 0000 0000 and the averaging process begins again with no loss of data ( the shift clock finishes the 24th pulse before the next  $V_N$  or  $V_E$  count).

The "scan counter", I15, is clocked by one count every time the 24 bits of velocity data are shifted from the accumulators into the "shift registers", I1 and I2. I15 is a ten counter with decoded outputs. The decode "1" state (pin 2) occurs every ten counts (i.e. after 10N minutes where N is the binary number represented at connector pins 5, 4, 3 and 2). The "1" state is used as a FORMAT control; the "1" state signals the recorder to clock out the 10 sets of stored velocity averages along with other data (generated on the time and temperature card) and record the data on cassette tape.

When this recording process occurs, data is streamed through the serial "shift registers" ("in" connector pin I1 and "out" connector pin 29) by means of the RECORDER CLOCK gated through I14. Note that the RECORDER CLOCK does not begin until well after the 24 bit shift has occurred. Also note that the 24 bit shift clock is used on the time and temperature card to shift out the time, compass, temperature and status data into the shift registers I11, I8 and I5. Only the tenth group of time, compass, temperature and status bits are actually streamed through the complete length of "shift registers" (by the RECORDER CLOCK).

The operation of this card is slightly different the first time after an INITIALIZE pulse is received. The INITIALIZE pulse loads the internal count, N, into down-counter I16 and resets the "scan counter" I15 to state "0". The result of this is that the first FORMAT pulse (and data recording) will occur after N minutes with the subsequent FORMAT pulses occurring every 10 N minutes. This allows the user (who is setting the clock and initializing) to recover data for check-out purposes after only N minutes (rather than 10 N minutes). Note that for this first record, the velocity data is generally not valid.

Referring back to the accumulators, it can be seen that when the accumulators are reset they are loaded with binary number 1000 0000 0000. This representation is "offset binary", some binary numbers and equivalents are listed below in Table 4.5.1-1.

Note that the electronics are set-up to represent exactly  $180^\circ$  of phase difference in the acoustic signals at fullscale. The correspondence to water velocity is dependent on the sound velocity.

TABLE 4.5.1-1 BINARY VELOCITIES AND EQUIVALENTS

OFFSET BINARY	OFFSET DECIMAL	DECIMAL	NOMINAL VELOCITY REPRESENTATION	PHASE
1111 1111 1111	4095	2047	+Fullscale*(1-1/2048)	+180*(1-1/2048) <sup>o</sup>
1000 0000 0001	2049	1	+Fullscale*(1/2048)	180/2048 <sup>o</sup>
1000 0000 0000	2048	0	0	0 <sup>o</sup>
0111 1111 1111	2047	-1	-Fullscale (1/2048)	-180/2048 <sup>o</sup>
0000 0000 0000	0	-2048	-Fullscale	-180 <sup>o</sup>

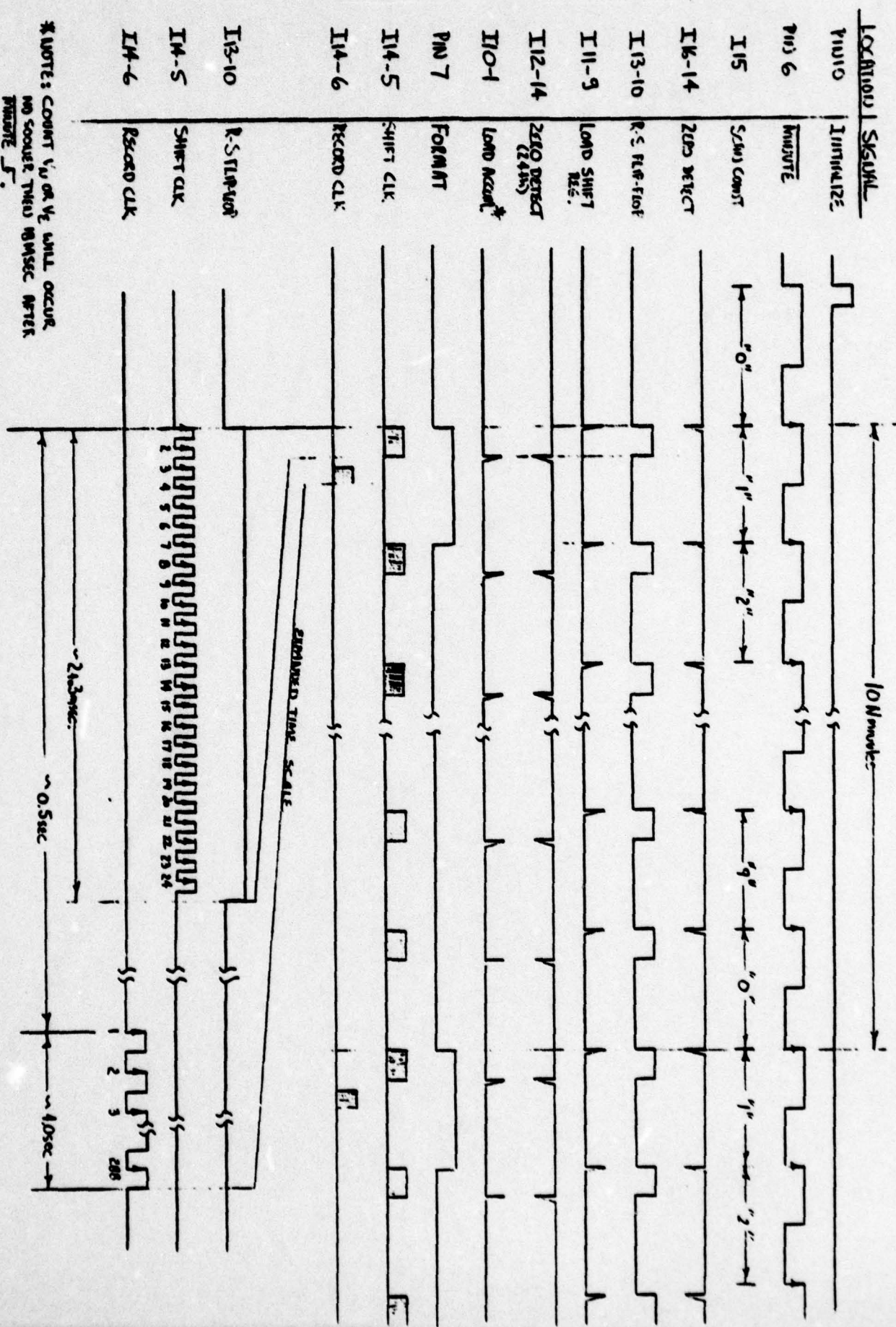

FIGURE 4.5.1-1 ACCUMULATOR CARD TIMING DIAGRAM (N = 1 MINUTE)

## THERMISTOR

The thermistor used in the ACM-1 is a Yellow Springs Instrument Company part number 44202. The thermistor bead is epoxy potted into the head of a 3/8" x 16-1/2" brass bolt which is in turn screwed into the electronics side of the sensor end-cap. The thermistor itself has an accuracy of  $\pm 0.15^{\circ}\text{C}$  and linearity deviation of  $\pm 0.065^{\circ}\text{C}$ . The thermistor time constant, as fitted to the instrument housing, is approximately 5 minutes to the outside water. The thermistor as configured, yields temperature data with the required accuracy to be used to correct the current velocity data for sound velocity variations with temperature.

YSI thermistor number 44202 when used with a resistor and drive network produces a linear current response with temperature. This circuit and the digitization of the temperature voltage is discussed in the section on the time and temperature card. The basic thermistor network is given by Figure 4.5.2-1 and by equation (1).

$$R_T = 5700 / (0.0056846 T + 0.194142) \quad (1)$$

where  $R_T$  is the equivalent resistance and  $T$  is the temperature in degrees Celcius. Note that the thermistor at  $25^{\circ}\text{C}$  will show the measured resistances (when disconnected from the time and temperature card) as tabulated below.

ORANGE TO BLACK 6Kohm

RED TO BLACK 30Kohm

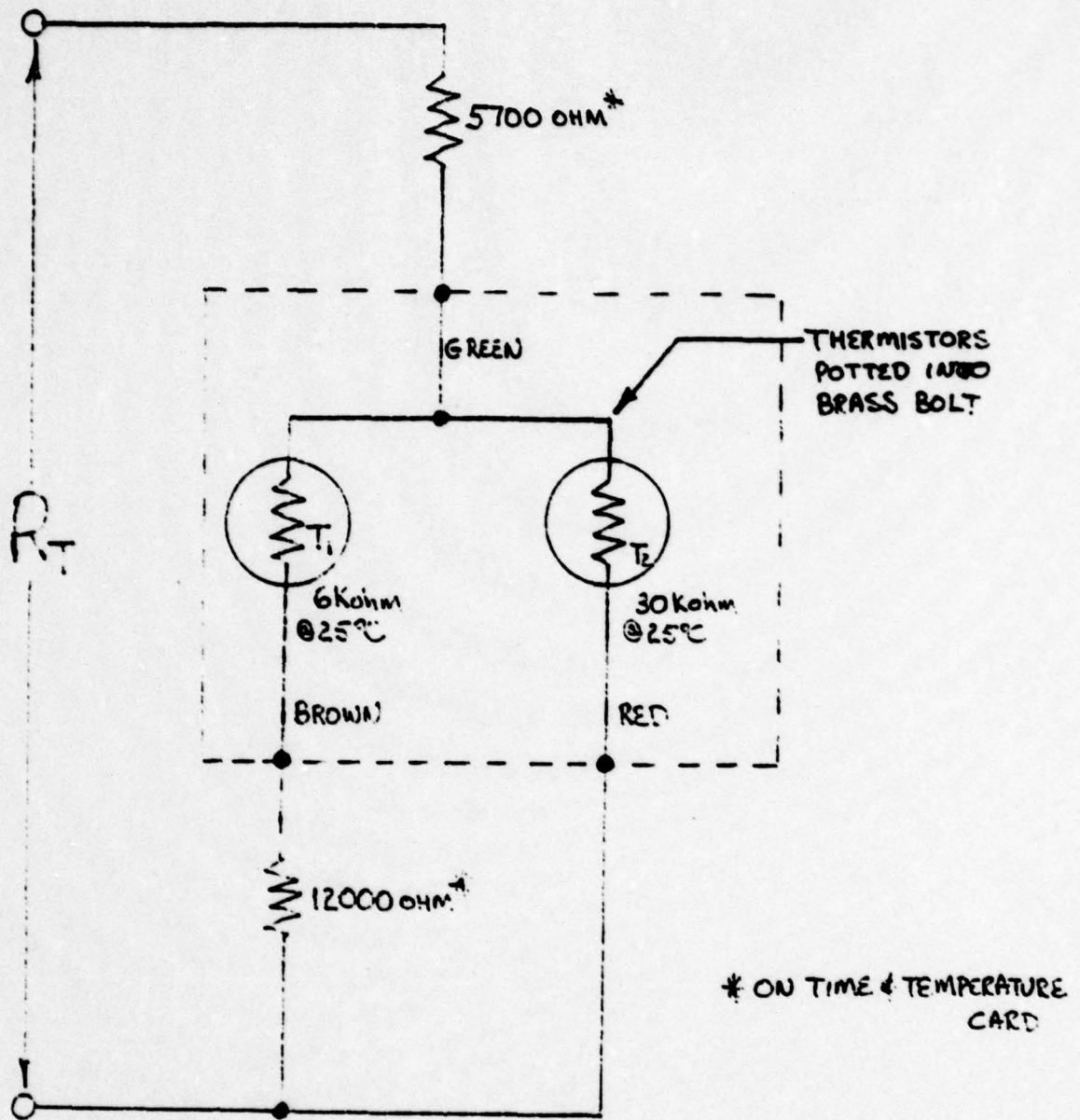

$$R_T = 5700 / (0.0056846T + 0.194142)$$

FIGURE 4.5.2-1 ACM-1 THERMISTOR NETWORK

T40024B

## TIME AND TEMPERATURE CARD

The time and temperature card performs the multiple functions of keeping track of binary minutes as time; resolving the compass heading for an 8-bit compass word; interfacing the thermistor and digitizing the temperature; and compiling the four bits of status. These data words are combined with the 8 bit header word (set by jumpers at I16) in serial "shift registers". The data is clocked out at the appropriate times by the accumulator card and the formatter card.

The 34.133 Hz clock is divided down by 2048 at I1 to produce the MINUTE signal. This MINUTE clock is used to increment the minutes "counters" (I7 and I12); to load the serial "shift registers" I6, I9 and I11 with the time count; to load the "shift registers" I11 with status; to load the "shift register" I15 with the temperature word; and to load the "shift register" I16 with the header word. The MINUTE signal is also used by the accumulator card to control the velocity averaging and to signal when the cassette recording is required. Note that the MINUTE signal to the time "counters" is 'OR'ed with the external CLOCK SET signal. This allows the user to set the minutes "counters" to any predetermined value by means of a fast clock signal (after resetting the counters by means of CLOCK RESET and I2). Note that the CLOCK RESET signal and I2 produce the INITIALIZE signal used by the accumulator card. The fast clock is controlled to have the same number of pulses as the count to be set into

the counters. The Time Set/Data Readout accessory is used for this function (see Section 2.0).

Of the four status bits, one is not used and is tied low. The ACOUSTIC Y and ACOUSTIC X signals are AC signals if the transmitted acoustic signals are being received, amplified and filtered by the interface cards and velocity sensor. These signals are filtered by Q1 and Q2 respectively (and associated components) to produce logic zeros in the presences of AC input. In the absense of the AC input these two status lines remain in a logic one state. The fourth status bit is the OSCILLATOR LOCK signal from the oscillator card. As long as the local and carrier oscillators are locked together by the 34 Hz difference frequency this line will be at a logic zero.

The signal processor signals of  $\sin(\omega t)$  called "RESOLVER "REF OUT" and  $\sin(\omega t - \phi)$  called RESOLVER TP4 contain the instrument heading (relative to magnetic North) information. These two 34 Hz signals with phase difference  $\phi$  (the angle of interest) are inputs to the logic network of I4 and I5. The RESOLVER "REF OUT" signal clocks I5 (pin 11) and this gates through a 16384 Hz clock to compass counter I10. The RESOLVER TP4 signal clocks I5 (pin 3) which is synchronized by the 16384 Hz clock and turns off the 16384 Hz clock to the compass counter and after a short delay resets the compass counter. The number of counts gated through I8 to the compass counter is directly related to  $\phi$ , the value of interest. Since the ratio of 34.133 to 16384 is 480, the number of COMPASS COUNTS (con-

nector pin 13) will be 0 to 480 directly related  $\phi$ . Each count will have equivalent weight of 0.75 degrees. Note that this burst of 16384 Hz signals will occur on a 34 Hz duty cycle. I4 (pin 12) will force the first completed count total to be held in "shift register" I13 after the 15 second signal goes high. This count will remain in shift registers until the next high transition of the 15 second signal (i.e. 7.5 seconds after the minute mark) or if shifted out by the DATA CLOCK 1 signal from the accumulator card. Note that the "shift register" only maintains the most-significant eight bits of the compass count. The LSB in the shift register (and as recorded on cassette tape) is therefore weighted  $1.5^0$ . Recall that the compass output is continually used in the signal processing procedure and this 8-bit word is only useful as an operational check.

The temperature circuitry consists of integrator I3 and associated components and flip-flop I2. The parallel combination of 34.8K and 6.81K form the 5700 ohm resistor (see Figure 4.5.2-1) of the thermistor network. A voltage through this network produces a current into the summing junction of integrator I3 linearly related to temperature. FET switch Q3 controls the current into the summing junction of opposite polarity. Balancing current decisions are made at a 34 Hz rate by I2 dependent on the state of integrator output (the 'D' input to I2). Resistance values have to be chosen so that at  $-2.4^{\circ}\text{C}$  the FET switch Q3 does not close; in other words, flip-flop I2 does not clock and no counts are transmitted to temperature counter I14. At  $35.25^{\circ}\text{C}$  the FET switch Q3 closes 255 times in the temperature averaging interval and this count is transmitted to the temperature counter I14. The temperature averaging

interval is controlled by the 15 second clock from counter I1 through the reset of the temperature counter I14. Temperature counter I14 is reset midway through the 15 second clock and is held in the serial "shift register" I15 starting at the minute mark until shifted out or reloaded. The temperature data represents the accumulated counts during the 7.5 seconds preceding the minute mark used to start the recording process; other temperature data points are lost. Full-scale temperature ( $35.85^{\circ}\text{C}$ ) at connector pin 27 (TEMPERATURE COUNTS) is represented by 34 Hz and  $2.4^{\circ}\text{C}$  is represented by 0 Hz. The bit weight of data as recorded on tape is  $0.15^{\circ}\text{C}$ . The conversion of recorded data to temperature is given by equation (1).

$$T = N_{\text{temp}} \frac{38.25}{255} - 2.4 \quad (1)$$

where  $N_{\text{temp}}$  is the temperature data as recorded on cassette tape.

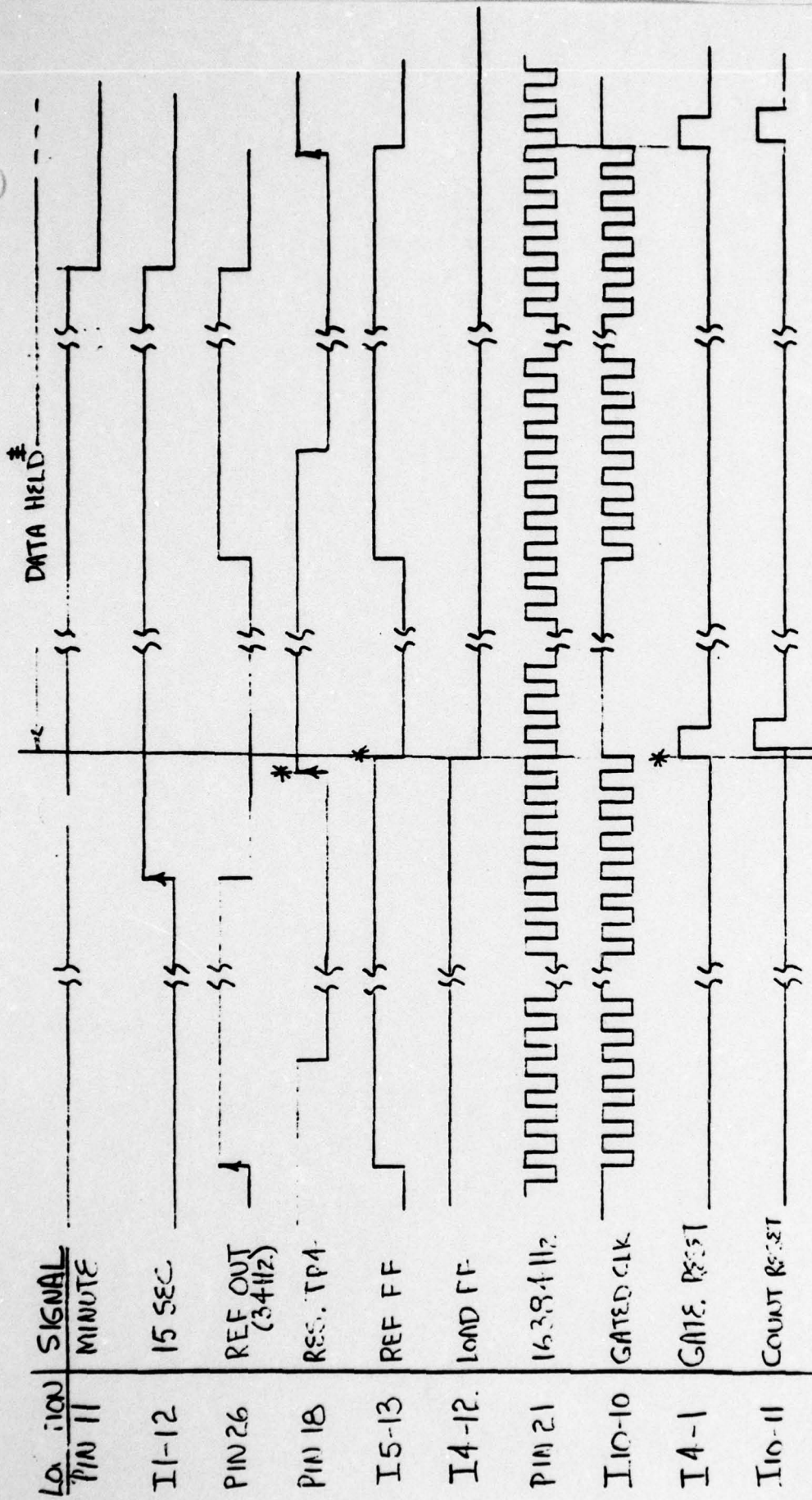

\* NOTE: SIGNAL "RES TP4" OCCURS ASYNCHRONOUS. SIGNALS "GATE RESET" AND "REF FF" OCCUR AT NEXT 16384 HZ.

\* NOTE: DATA HELD FROM FIRST COMPLETE COUNT AFTER "15 SEC" TO NEXT "15 SEC" (APPROXIMATELY 7.5 SEC. BEFORE TO 7.5 SEC. AFTER MINUTE).

FIGURE 4.5.3-1 TIME AND TEMPERATURE CARD COMPASS TIMING DIAGRAM

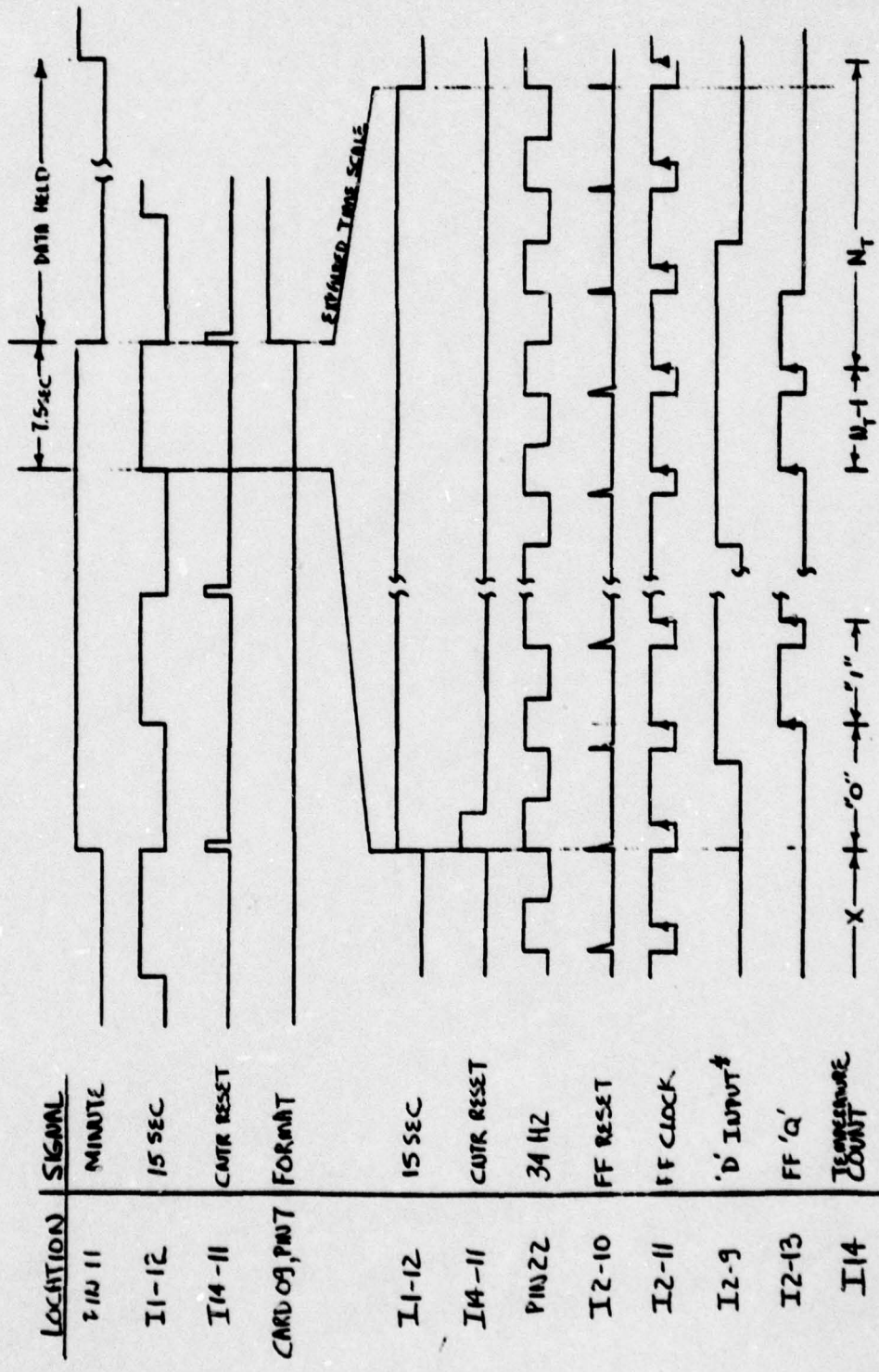

\* NOTE: ACTUAL SIGNAL IS A BURST UP OR DOWN.

FIGURE 4.5.3-2 TIME AND TEMPERATURE CARD TEMPERATURE TIMING DIAGRAM

## RECORDING FUNCTION (MEMODYNE)

The recording of the ACM-1 data on cassette tapes is handled by the formatter card and the Memodyne recorder as blocked out on Figure 4.6-1. A FORMAT command is generated on the accumulator card after  $10N$  minutes (where  $N$  is the averaging time of 1 to 15 minutes). At this time, ten sets of current components; a temperature word; a compass heading word; binary minutes as time; four bits of status; and a header word are stored in serial shift registers. The FORMAT command starts the recording process and the shifting out of the stored data as described in the following subsections.

Fig. 4.6-1

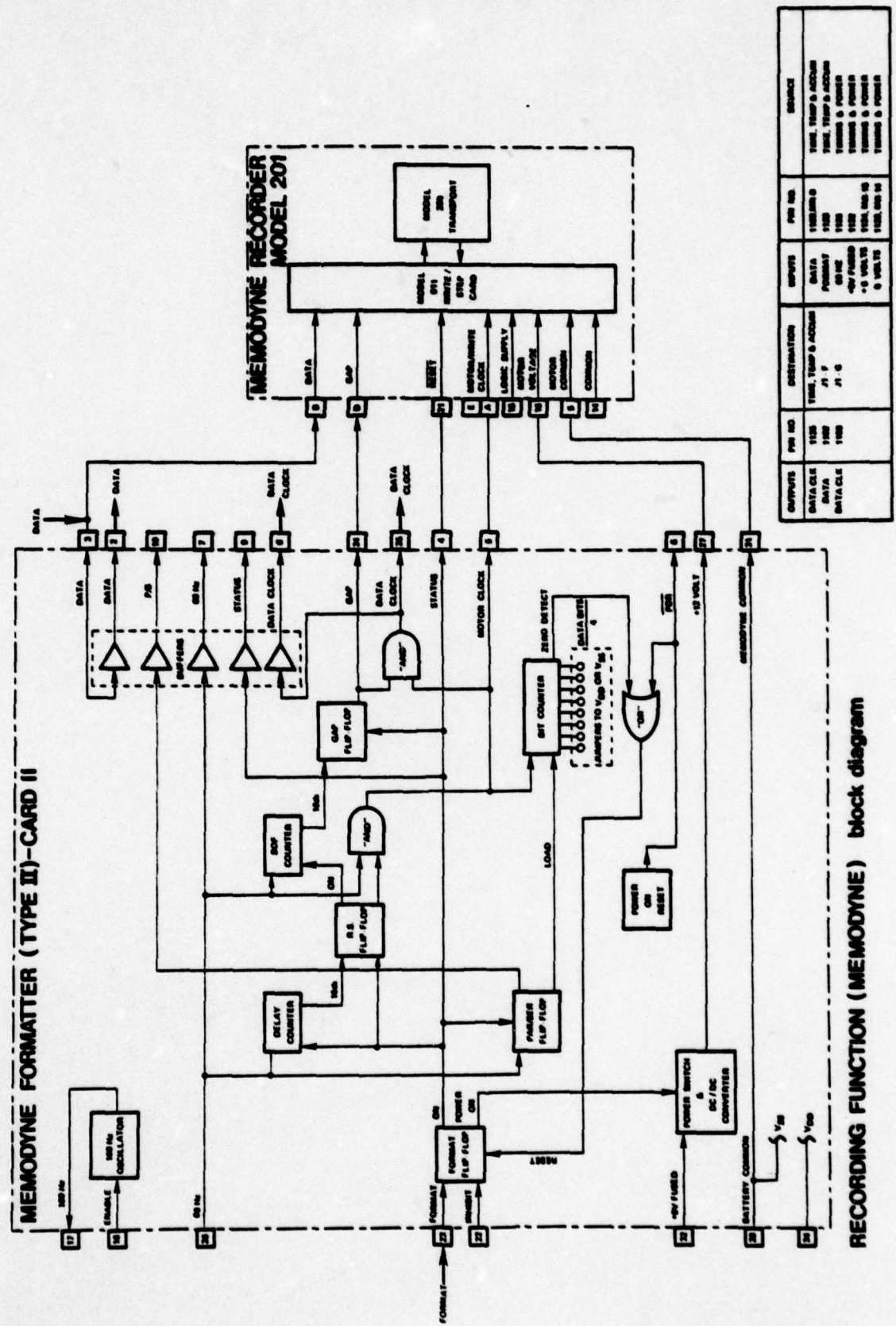

## MEMODYNE RECORDER

The recorder is a Memodyne model 201 which includes a model 911 write/step card and model 200 transport. The Memodyne manual is included in the Appendix. The required signals to interface the recorder are summarized below.

<u>SIGNAL</u>	<u>DESCRIPTION</u>
WRITE CLOCK	Steps tape one bit/pulse
DATA IN	Selects 0 or 1 to be written
GAP	Inhibits data to be written
STATUS	Resets input
+12V	Motor voltage
MOTOR COMMON	Motor Common
+6V	CMOS compatible power
GROUND	Logic common

Note that the Memodyne recorder writes one bit at a time (615 BPI at 0 to 100 steps/sec) using two tracks and uses 16 bit inter-record gaps. The recorder is write-only.

## MEMODYNE FORMATTER (TYPE II) CARD

The Memodyne formatter (type II) card inserts a beginning-of-file gap and clocks out the data from the various shift registers when a FORMAT signal is received at connector pin 23 (see waveforms). A 68Hz clock (connector pin 26) is used for the motor and data clock pulses. The rising edge of FORMAT sets "format flip-flop" I6 (pin 1) (INHIBIT is normally tied high). The setting of the "format flip-flop" turns on the power to the Memodyne motors through "power switch" Q1 and Q2 and the "DC-to-DC converter". Note that potentiometer P1 is adjusted to provide +12 volts at the output of the 5 to 12 volt "DC-to-DC converter".

The setting of the "format flip-flop" enables the "delay counter" and "gap flip-flop"; resets the "parallel/serial flip-flop"; and puts the STATUS signal (clear signal to the recorder) to logic zero. The "parallel/serial flip-flop", I8 (pin 1), is clocked after one 68 Hz cycle. The "delay counter", I2, counts sixteen clock pulses allowing time for the +12 volt power to the recorder to settle. At the sixteenth count the "R-S flip-flop", I3, sets allowing MOTOR CLOCKS to the recorder. The "beginning-of-file counter", IC7 is enabled and counts sixteen clock pulses while the GAP signal to the recorder is still high; thereby writing a sixteen bit gap on the tape. After these sixteen pulses, the "gap flip-flop", IC6 (pin 12) is set low and GAP goes low. This also allows the "bit

counter", I5 and I9, to begin counting the required number of data bits. After the GAP signal goes low, data is clocked out of the various serial shift registers and recorded on tape by means of the DATA CLOCK signal to the accumulator and time-temperature cards. The ZERO DETECT out of the "bit counter" resets the "format flip-flop" and power is turned off to the Memodyne motors and the recording is complete. Note that the "bit counter" is a down-counter and it is preloaded (by the "parallel/serial flip-flop") with the number of data bits to be recorded divided by four as set by jumpers (i.e. for 288 bits the jumpers represent  $72 = 64 + 8$ ).

Buffered outputs of the 68Hz, STATUS, P/S, DATA CLOCK, and DATA are made available. The DATA and DATA CLOCK signals can be used by a Time Set/Data Readout box to read the data values (see Section 2.0). A POWER-ON RESET pulse is generated on this card when power is first turned on. A 100Hz oscillator is also on this card but is generally not used in the ACM-1.

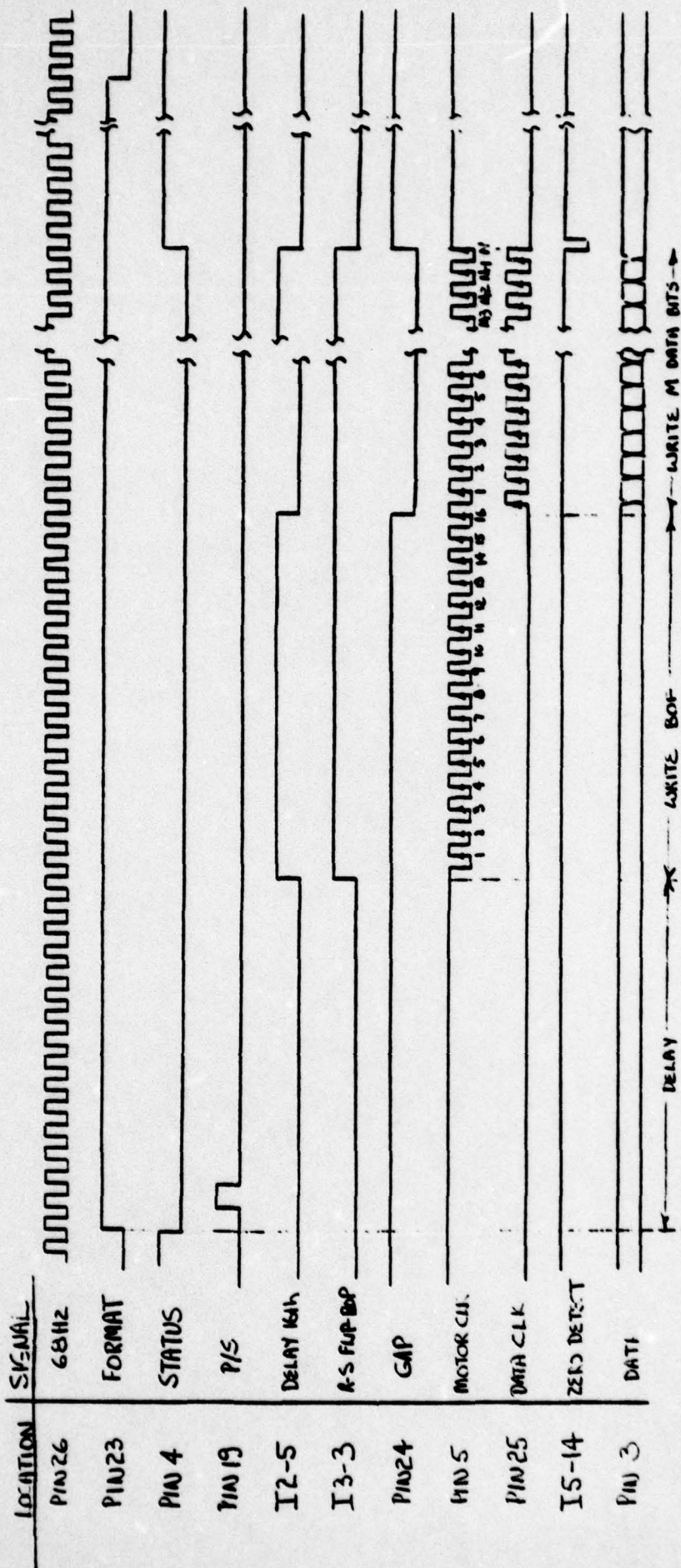

FIGURE 4.6.2-1 MEMODYNE FORMATTER (TYPE II) CARD TIMING DIAGRAM

## RECORDING FUNCTION (SEA DATA)

The recording of the ACM-1 data on cassette tapes is handled by the three Sea Data cards and recorder. A FORMAT command is generated on the accumulator card after  $10N$  minutes (where  $N$  is the averaging time of 1 to 15 minutes). At this time, ten sets of current components; a temperature word; a compass heading word; binary minutes as time; four bits of status; and a header word are stored in serial shift registers. The FORMAT command starts the recording process and the shifting out of the stored data as described in the Sea Data manual (see Appendix).

The Sea Data model 610 includes the following cards:

CR-30 Format control

CR-21 Head driver

CR-12 Motor driver

These cards all are provided with the modification to work at 5 volts. The transport is model 64H. The required signals to interface the Sea Data cards and recorder are summarized below.

<u>SIGNAL</u>	<u>DESCRIPTION</u>
FORMAT	Command to recorder to start recording process
SERIAL DATA	Data as clocked to recorder from shift registers.
DATA CLOCK	Shift register recorder clock from recorder
+16V	Motor voltage
MOTOR COMMON	Motor common
+6V	CMOS compatible power
GROUND	Logic common

The "gap length counter" on the formatter card is normally wired for a 10 step gap plus the two steps of preamble. The "character counter" on the formatter card is wired for the number of data bits divided by four (the Sea Data recorder writes four tracks or bits per step). Normally for the 288 bit message, the "character counter" is wired for 72. A one step parity bit is written at the end of the data.

## SETTING AVERAGING INTERVAL

The four connector wires that control the value of N (the averaging interval) are normally jumpered together on the two analog-to-digital converter cards and the accumulator card. This insures that when changes are made in N, both the averaging interval and scale factor change accordingly. The result is that the full-scale value of the data will be the same for all averaging intervals (1 to 15 minutes). The jumper connections required for the various averaging intervals are listed below.

INTERVAL	ACCUMULATOR PIN NO.			
	0905	0904	0903	0902
1	1	0	0	0
2	0	1	0	0
3	1	1	0	0
4	0	0	1	0
5	1	0	1	0
6	0	1	1	0
7	1	1	1	0
8	0	0	0	1
9	1	0	0	1
10	0	1	0	1
11	1	1	0	1
12	0	0	1	1
13	1	0	1	1
14	0	1	1	1
15	1	1	1	1

Note: 1= $V_{DD}$  or PIN NO. 0934

0= $V_{SS}$  or PIN NO. 0933

## SETTING HEADER DATA JUMPERS

The eight bits of header data on each record are set by jumpers on the time and temperature card. Refer to the card layout for the location of the header jumpers. To set a header bit to "1", jumper to  $V_{DD}$ ; and to set a header bit to "0", jumper to  $V_{SS}$ .

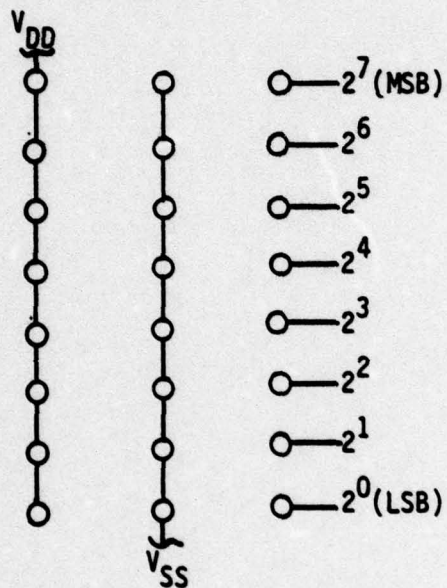

ARRANGEMENT OF HEADER JUMPER HOLES

### ELECTRONICS ADJUSTMENT AND CALIBRATION

The following adjustment and calibration procedures are designed to allow the user to fully set-up the current meter. Note that a calibrated meter does not require the use of a tow-tank or calibration standard; calibrated output is dependent only on the acoustic frequency, the transducer spacing (a fixed item), and the proper setting of electronics as outlined in this section. It is assumed that the user attempting to set-up the ACM-1 meter has a thorough understanding of the operation of the meter as described in section 4.0.

The following equipment is required:

1. Oscilloscope
2. Oscillator (Sine Wave 21 to 54 Hz)
3. DC power supplies
4. Frequency meter
5. Voltmeter (high impedance)

## OSCILLATOR CARD ADJUSTMENT

1. Local Oscillator Amplitude. With a 10X probe between TP6 and analog common observe a sine wave of 1.605 MHz on an oscilloscope. Adjust T2 with a non-metallic tuning wand for maximum amplitude.

$$TP6 = 300 \text{ mvp-p} \pm 10\%$$

2. Carrier Oscillator Amplitude. With a 10X probe between TP5 and analog common observe 91.5 usec. bursts of 1.605 MHz sine wave on an oscilloscope. Note: be sure the interface cards are in place to provide proper loading. With the shield cover on, adjust T1 with a non-metallic tuning wand for maximum amplitude.

$$TP5 = 200 \text{ mvp-p} \pm 10\%$$

3. Phase Detector Operation. With a 10X probe between TP4 and analog common observe this FREQUENCY ADJUST signal to be a series of positive/negative chargings at 34 Hz. Adjust C18 for an average level of 0 volts at TP4 at room temperature. This level should not change by more than  $\pm 1.0$  volts for the complete range of operating temperatures (the absolute limit of phase detector operation is  $\pm 2.0$  volts). Note: during a "cold test" this signal should be monitored.

$$TP4 = 0 \text{ volts} \pm 1.0 \text{ volts over temperature range}$$

Observe the MIXER signal at TP2 to be approximately a sine wave at 34 Hz.

$$TP2 = 80 \text{ mvp-p} \pm 20 \text{ mvp-p}$$

Verify that the loop status signal, OSC. LOCK, at pin 30 is at logic zero.

$$OSC. LOCK = \text{logic zero}$$

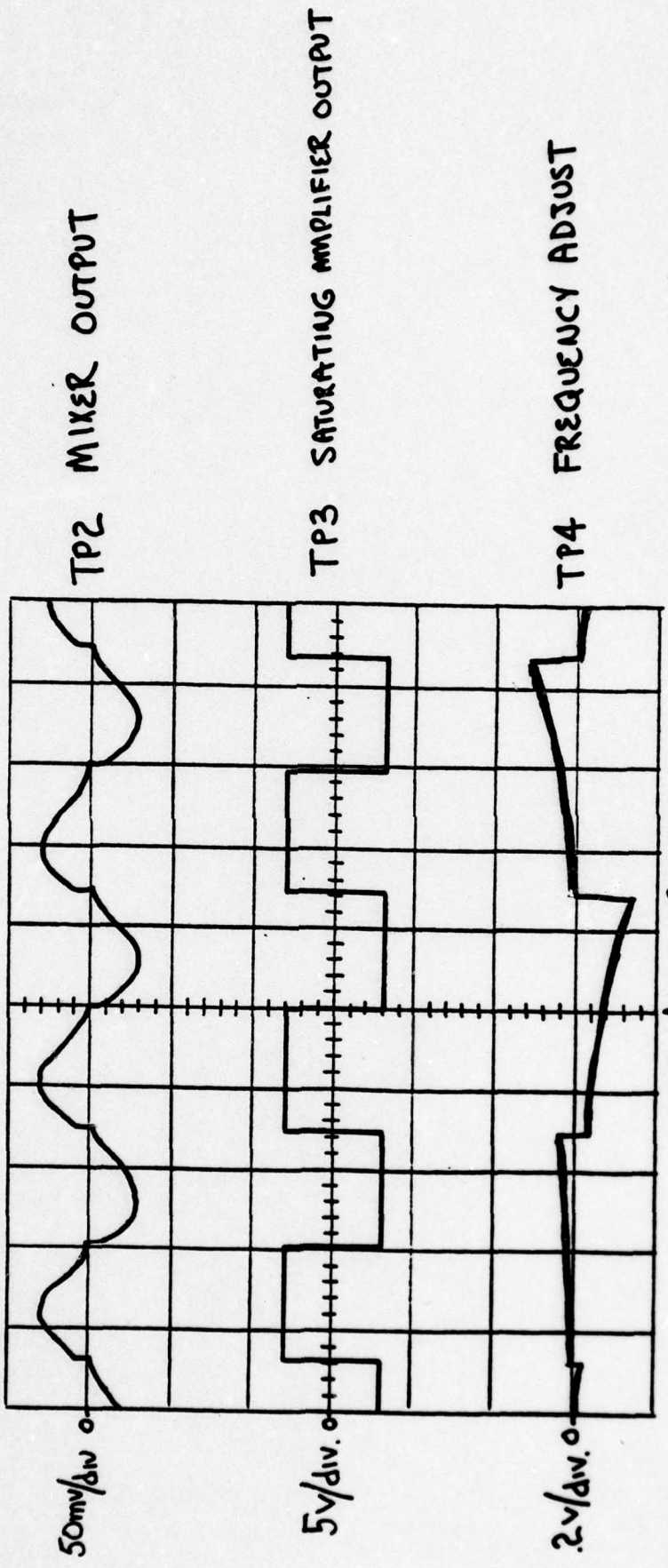

OSCILLATOR CARD OSCILLOSCOPE WAVEFORMS

### Velocity Interface Card Adjustment and Calibration

1. Bandpass Filter Check. With the transducer out of the water or with the oscillator card removed, connect a 1vp-p sine wave oscillator through 1.2M ohm to TP1. Connect a 10X oscilloscope probe between TP3 and analog common. Measure the gain of the bandpass filter as tabulated below.

<u>Frequency</u>	<u>Input (vp-p)</u>	<u>Output (vp-p)</u>
21 Hz	1.0 vp-p	2 vp-p $\pm$ 10%
34 Hz	1.0 vp-p	1 vp-p $\pm$ 10%
54 Hz	1.0 vp-p	2 vp-p $\pm$ 10%

Repeat the check applying the signal to TP2 and observing at TP4.

2. Mixer Amplitude. With the transducer in water (as deep as possible in a one meter cube of water) and the oscillator card installed, tune T3 for maximum 34 Hz sine wave signal at TP3 and tune T4 for maximum 34 Hz sine wave signal at TP4.

$$TP3(4) = 2 \text{ vp-p} \pm 0.5 \text{ vp-p}$$

Note that R6 and R25 are chosen to achieve this level and are nominally 56 ohms. If this level is not achieved, check for bubbles or debris on the transducer or acoustic mirror.

3. Phasemeter Operation. Observe between TP7 and analog common with an oscilloscope. This UNFILTERED OUT. signal should normally be zero volts with narrow square pulses to logic one or logic zero level (i.e.  $\pm$ 3 volts from analog common). Gently move the transducer and observe positive pulses for negative water flow (the transducer moving toward positive axis) and negative pulses for positive water flow. (See Figure 4.1.3-2)

4. Zero Flow Adjustment. With the transducer in still water, adjust P1 for a  $V_x$  ( $V_y$ ) signal of zero volts DC. Measure between pin 10 or the test connector (J1) and analog common with a digital voltmeter.

$$V_x (V_y) = 0.000 \text{ VDC} \pm 2 \text{ mVDC}$$

5. Fullscale Adjustment. With the transducer out of the water or the oscillator card removed, attach +6 volts DC ( $V_+$ ,  $V_{DD}$ ) through 100K to TP3 and 0 volts DC ( $V_-$ ,  $V_{SS}$ ) through 100K to TP4. Momentarily touch the 34 Hz reference signal (power and timing card pin 04) through a 4.7M ohm resistor to TP1. This setup clocks the phasemeter circuitry to a locked position of fullscale. Adjust P2 for the fullscale level; measure between pin 10 or the test connector (J1) and analog common with a digital voltmeter.

$$V_x (V_y) = +2.000 \text{ VDC} \pm 2 \text{ mVDC}$$

Check the negative fullscale output by momentarily touching the 34 Hz reference signal through a 4.7M ohm resistor to TP2.

$$V_x (V_y) = -2.000 \text{ VDC} \pm 4 \text{ mVDC}$$

6. Half-scale Check. Attach +6 volts DC ( $V_+$ ,  $V_{DD}$ ) through 100K to TP4 and connect the 34 Hz reference signal through 4.7M ohm to TP1. Measure the output signal. (Oscillator or transducer removed.)

$$V_x (V_y) = +1.00 \text{ VDC} \pm .02 \text{ VDC}$$

Attach +6 volts DC ( $V_+$ ,  $V_{DD}$ ) through 100K to TP3 and connect the 34 Hz reference signal through 4.7M ohm to TP2. Measure the output signal.

$$V_x (V_y) = -1.00 \text{ VDC} \pm .02 \text{ VDC}$$

Note: this half-scale check does not imply anything about the

quality of the linearity, as long as the check is within the tolerances. The "mixer" output is being forced by a square-wave and the higher harmonics cause distortion.

48 Bursts of 1.605 MHz per cycle of 39.133 Hz

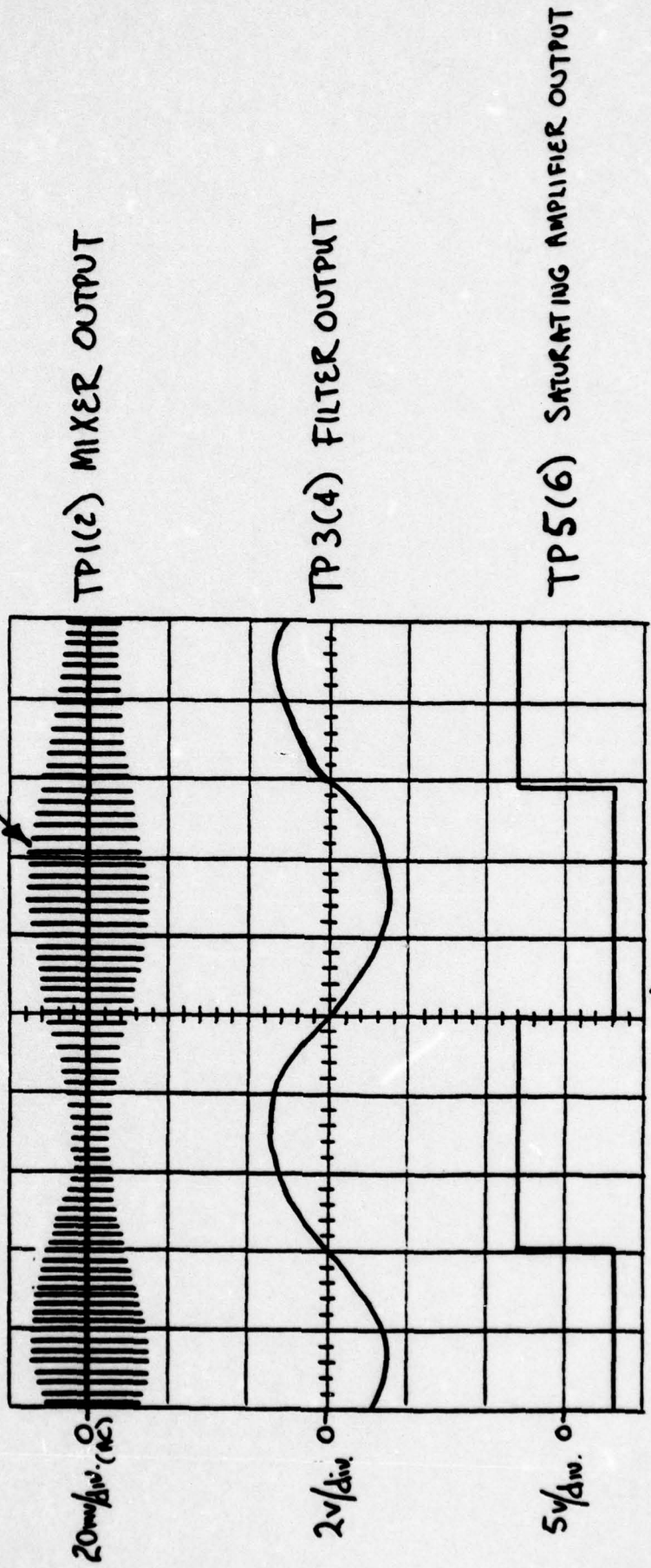

gnd = Analog common  
5msec/div.

# VELOCITY INTERFACE CARD OSCILLOSCOPE WAVEFORMS

## Compass Electronics Adjustment

1. Verify Drive Frequency. Measure the frequency of the drive signal at I7-13.

$$\text{Drive} = 1200 \pm 200 \text{ Hz}$$

2. Hx, Hy Behavior. Verify that Hx and Hy are nominally  $\pm 1.0$  volts DC fullscale and change as predicted with heading. Swing compass if desired and record Hx and Hy.

3. Compass Adjustment. The adjustment of the compass is difficult without a special turntable jig and is not recommended to the user. The procedure used at NBIS is as follows:

- a) Install compass card to be calibrated into test fixture. Apply power.
- b) Mount compass on turntable. Set turntable to approximately North.
- c) Adjust "X Tilt", P1, at TP1 for  $0 \pm 0.1$  VDC.
- d) Adjust "Y Tilt", P4, at TP3 for  $0 \pm 0.1$  VDC.
- e) Set "Sym", P3, at TP2 for  $0 \pm 0.1$  VDC.
- f) Set "X Scale", P2, and "Y Scale", P5, fully counter clockwise.
- g) Turn outer table for  $H_y = 0 \pm 0.001$  VDC and lock table.
- h) Rotate  $180^\circ$  CW, adjust "Y Tilt", P4, for half reading.
- i) Rotate  $90^\circ$  CCW (east). Set turntable for  $H_x = 0 \pm 0.001$  VDC.
- j) Rotate  $180^\circ$  CW (west), adjust "X Tilt", P1, for half reading.

- k) Detent table to North. Adjust outer ring for  $H_y = 0 \pm 0.001$  VDC. Lock ring.
- l) Rotate detent  $180^\circ$  (south). Adjust "Y Tilt", P4, for half reading.
- m) Adjust outer ring for  $H_y = 0 \pm 0.001$  VDC. Lock ring. Rotate detent  $180^\circ$  and check zero.
- n) Perform steps k), l), and m) for  $H_x$ .
- o) Adjust "X Scale", P2, for  $H_x = 1v \pm 0.002$  VDC.
- p) Rotate detent  $90^\circ$  CW. Adjust "Y Scale", P5, for  $H_y = 1.0 V \pm 0.002$  VDC.
- q) Adjust ring for  $H_x = 0 \pm 0.001$  VDC. Lock ring. Rotate detent  $90^\circ$  CCW. Adjust "Sym", P3, for  $H_y = 0 \pm 0.001$  VDC.
- r) Adjust ring for  $H_x =$  positive,  $H_y = 0 \pm 0.001$  VDC. Lock ring. Rotate CW and verify values.

	$H_y$	$H_x$
$0^\circ$	0	+
$90^\circ$	+	0
$180^\circ$	0	-
$270^\circ$	-	0
$360^\circ$	0	+

- s) Use reference compass to set table to actual North. Lock outer ring. Adjust compass lid for  $H_y = 0 \pm 0.001$  VDC. Fill with oil and seal.
- t) Swing compass and record data every  $45^\circ$ . Verify performance to  $\pm 2^\circ$ .
- u) Tilt turntable at  $30^\circ$ . Swing compass and record data every  $90^\circ$ . Verify performance to  $\pm 2^\circ$ .

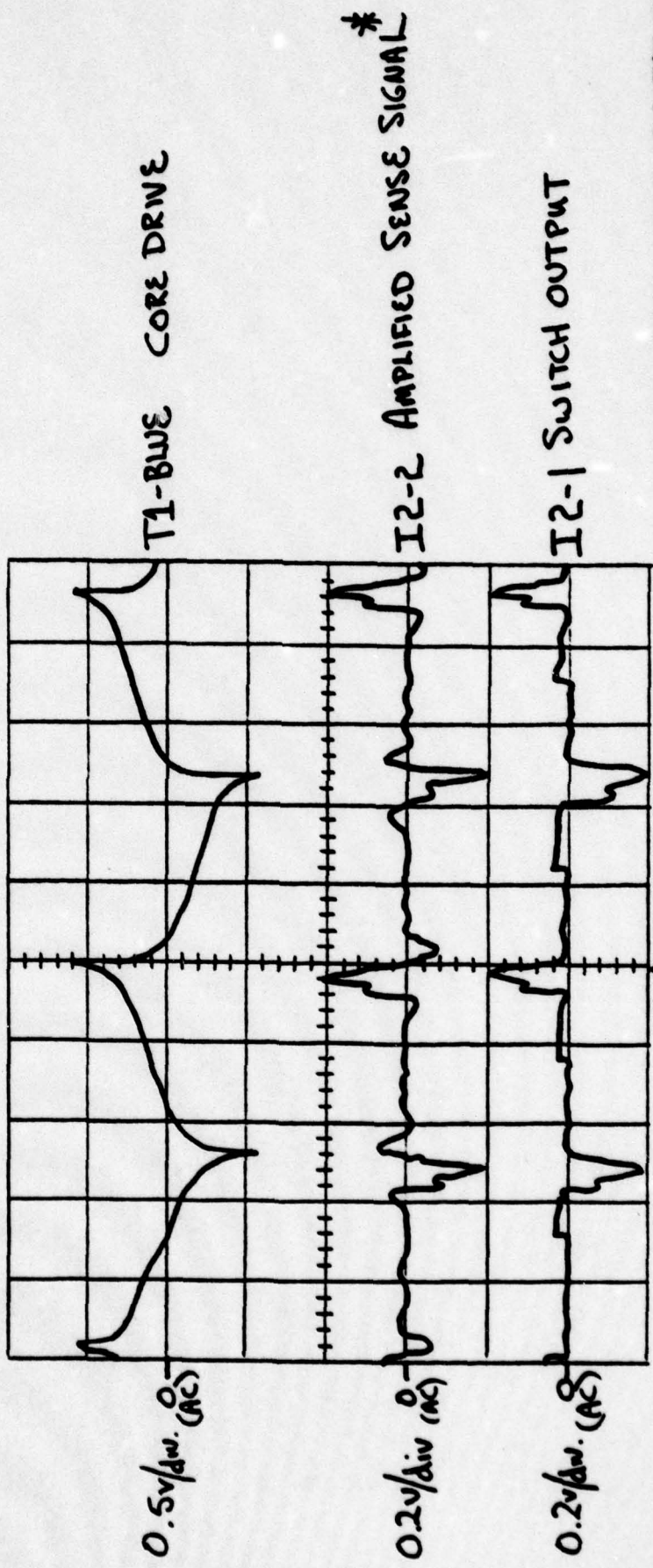

\* DEPENDENT ON THE ORIENTATION OF THE COMPASS

COMPASS ELECTRONICS CARD OSCILLOSCOPE WAVEFORMS (TYPICAL)

### Signal Processor Card Adjustment and Calibration

1. Processor Check. Remove interface cards and compass electronics card. Connect signals Vy (pin 30) and Hy (pin 28) to analog common. Connect Hx (pin 27) to +1.0 VDC and Vx (pin 29) to +2.0 VDC. Observe between TP1 and analog common a sine wave in-phase with the 34 Hz reference.

$$TP1 = 2.3 \text{ to } 2.6 \text{ vp-p}$$

Observe between TP3 and analog common a sine wave out of phase with the 34 Hz reference.

$$TP3 = 3.0 \text{ to } 3.35 \text{ vp-p}$$

2. Duty Cycle Adjustment. Connect signals Vx, Vy and Hy to analog common. Connect Hx to +0.05 VDC. Observe TP2 on an oscilloscope. Adjust P2 for a 34 Hz square-wave with 50% duty cycle.

$$TP2 = 34 \text{ Hz square-wave, } 50\% \text{ duty cycle}$$

3. Zero Adjustment. Connect Vx, Vy, Hx and Hy as in item 1 above. Adjust P3 for zero signal at  $V_E$  (pin 2). Note:  $V_E$  has a large AC component (mostly 68 Hz); an RC filter of 1M ohm and 4.7 uf and the use of a high impedance digital voltmeter is recommended or the use of an RMS reading meter.

$$V_E = 0.000 \text{ VDC}$$

4. Scale Adjustment. Connect Vx and Hy to analog common; connect Hx to +1.00 volts DC; and connect Vy to +2.600 volts DC. Measure  $V_E$  through the RC filter. Adjust P4 for correct scale. Note: it may be necessary to correct the digital voltmeter for the

voltage divider formed from the 1M ohm and the input impedance of the meter.

$$V_E = +1.300 \text{ volts DC}$$

Connect Vy and Hy to analog common; connect Hx to +1.00 volts DC; and connect Vx to +2.600 volts DC. Verify  $V_N$  (pin 3) through the RC filter and digital voltmeter.

$$V_N = +1.300 \text{ volts DC} \pm 3\text{MVDC}$$

5.3.4-1

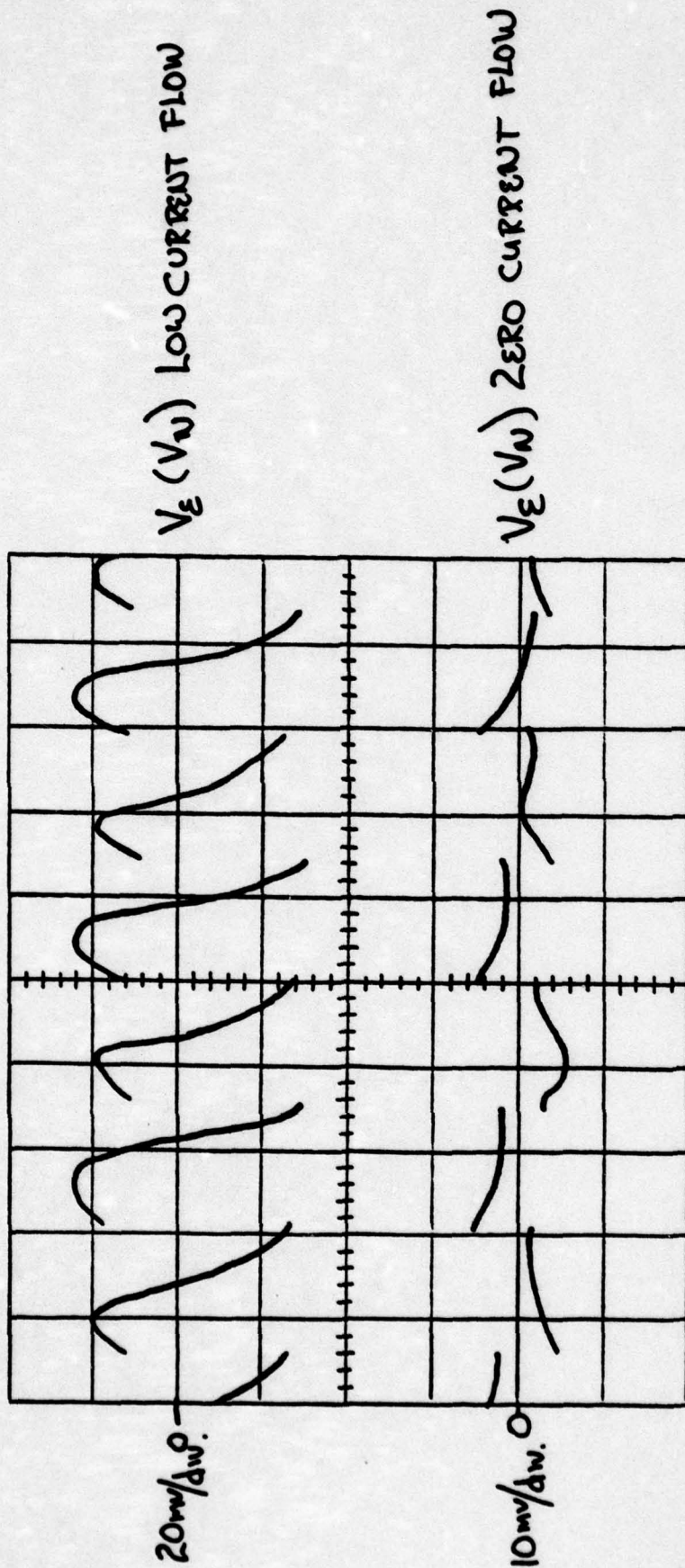

grd = Analog Common  
10msec/div.

SIGNAL PROCESSOR CARD OSCILLOSCOPE WAVEFORMS (TYPICAL)

## Power and Timing Card Adjustment

1. +6 Volt Adjustment. Monitor between pin 29 and 28 with a digital voltmeter. Adjust P1 for 6 volts DC.

$$\text{Pin 29} = +6.000 \text{ VDC} \pm 10 \text{ mVDC}$$

2. +3 Volt Adjustment. Monitor between pin 35 and 28 with a digital voltmeter. Adjust P2 for 3 volts DC.

$$\text{Pin 35} = +3.000 \text{ VDC} \pm 10 \text{ mVDC}$$

3. Current Drain Check. With the ON/OFF switch in the "off" position, connect a DC ammeter across the switch by hooking it to pins 30 and 32. Monitor the current drain from the +8 battery.

$$\begin{array}{l} \text{I supply} \\ \text{(recorder off)} \end{array} = 5.5 \text{ ma (typical)}$$

$$\begin{array}{l} \text{I supply} \\ \text{(Memodyne on)} \end{array} = 270 \text{ ma (typical)}$$

$$\begin{array}{l} \text{I supply} \\ \text{(Sea Data on)} \end{array} = 6.0 \text{ ma (typical)}$$

4. Check Oscillator. Verify with an oscilloscope or frequency meter the 32768 Hz clock (pin 1 to pin 31). Adjust C8 for a clock rate within 0.1 Hz.

$$\text{Pin 1} = 32768 \text{ Hz} \pm 0.1 \text{ Hz}$$

### Analog to Digital Converter Card Adjustment and Calibration

1. Zero Adjustment. Remove signal processor card. Connect the input line (pin 32) to analog common. Jumper a 100K ohm resistor across capacitor C1. Measure with a digital voltmeter across C1 with the meter common on the amplifier output (I1-6). Adjust P1 for zero volts (labeled as Z).

$$V_{C1} = 0.0000 \pm 0.1 \text{ mVDC}$$

2. Scale Adjustment. Set-up digital voltmeter and 100K ohm resistor as above, but connect the input line (pin 32) to + 1.000 volts DC. Connect pin 24 to analog common (pin 35) and pin 28 to +6 volts ( $V+$ ,  $V_{DD}$ ). Adjust P2 for zero volts on the meter (labeled as S).  
Note: this setup forces a balance with the fullscale input.

$$V_{C1} = 0.000 \pm 1 \text{ mVDC}$$

3. Digital Section Check. Remove the 100K ohm resistor and the digital meter. The frequency of count pulses at pin 15 is directly related to the input level (0 to  $\pm 1.000$  volts DC). The sign signal, pin 2, is logic one for positive input and logic zero for negative input.

$$\text{Count Fre-} \\ \text{quency (pin 15)} = (\text{Input}) 34.133/N$$

where N is the scale factor as jumpered on connector pins 4, 5, 6 and 3 (normally set to 1). Verify the frequency for several positive and negative inputs.

### Memodyne Formatter (Type II) Card Adjustment

1. +12 Volts Adjustment. Remove the accumulator card and connect pin 23 to 26 of the formatter card. This continually generates a FORMAT command and allows the +12 volts DC output to be monitored.

Note: with this procedure the +12 volts DC is on for almost 5 seconds and off for a fraction of a second. Monitor between pin 27 and 31 with a voltmeter. Adjust P1 for +12 volts DC.

Pin 27 = +12.0 VDC  $\pm$  0.1 VDC

## SEA DATA RECORDER ADJUSTMENT

Refer to the Sea Data manual for details of the recorder. The following items are suggested checks and adjustments. Note that the Sea Data can be made to run almost continuously by disconnecting the FORMAT signal on pin 28 of the Format Control card (CR-30) and connecting pin 28 to a 2-second clock (pin 2 of I1 on the time-temperature card is a clock of 1/32 minute or 1.875 seconds).

1. Oscillator Adjustment. Observe with an oscilloscope the oscillator test point on the head driver card (CR-21). Adjust R18 on CR-21 as required.

Oscillator = 1000 Hz

2. Half Step Adjustment. Observe IC2 pin 13 on the motor driver card (CR-12) with an oscilloscope (also available on connector pin 31). Adjust R48 on CR-12 for correct pulse width as required. Note that the Sea Data recorders normally supplied with the ACM-1 run at a speed of 100 steps/second.

Speed	Time
100	5.0 ±0.2 mSec
200	2.5 ±0.1 mSec
300	1.67 ±0.1 mSec

3. Record Length Check. With an oscilloscope, monitor pin 11 on the head driver card (CR-21). Synchronize the oscilloscope on pin 24 (TRANSPORT BUSY) of the head driver card for positive trigger. Observe that the HEAD COIL VOLTAGE MONITOR (pin 11) signal is low for the gap time (generally a 10 step gap at 100 steps/second for 100 mSec.) and then goes high for duration of

the record. The high time is the number of bits divided by four plus three all times the step time (for 288 bits at 100 steps/second the high time will be 750 mSec).

$$\text{HEAD VOLTAGE} = 100 \text{ mSec low} + 750 \text{ mSec high} \\ \text{(288 bits at 100 steps/Sec)}$$

4. Timing Check. Synchronize an oscilloscope on pin 24 (TRANSPORT BUSY) of the head driver card. Observe the following signals as tabulated below for a 10 step gap, 288 bits and 100 steps/second.

SIGNAL	CARD	PIN	WAVEFORM
PREAMBLE	CR-30	23	low 100 mSec, high 20 mSec.
PREAMBLE CODE	CR-30	22	low 100 mSec, high 10 mSec.
LCC SHIFT	CR-30	25	low 840 mSec, high 10 mSec.
SHIFT CLOCK	CR-21	18	73 bursts of 4 clocks
STORAGE REG. SHIFT CLOCK	CR-21	29	72 bursts of 4 clocks

5. Head Current Check. Extend the head driver card (CR-21) and connect an oscilloscope across R7. Using two probes in differential mode across R7 and synchronizing on the TRANSPORT BUSY signal is a satisfactory way of observing the head current. Observe positive and negative voltage excursions of about 1 volt. The repetition rate should be 10 mSec. Repeat for R6, R5 and R4.

By disconnecting the data line and connecting it (pin 13 on CR-21) to ground or  $V_{DD}$  a known pattern of all 0's or 1's can be observed.

6. Tension Tests. Follow procedures as outlined in the Sea Data manual to check the tension on the take-up and feed hubs.

## MAINTENANCE PROCEDURES

1. Replacing Battery Package. The lithium battery package should be changed after one year of normal use. The alkaline battery package should be changed after six months of normal use. Be sure to observe the following cautions with the lithium battery package.

--DO NOT SHORT OUTPUT

--DO NOT CHARGE BATTERIES OR USE IN CONJUNCTION WITH OTHER POWER SOURCES

--DO NOT DISPOSE OF IN FIRE

--DO NOT DISASSEMBLE

The following procedure can be used to change the battery packages.

- a) Power switch "off", connector J1 disconnected.
- b) Free battery wires of tie-downs.
- c) Remove the three nuts holding down the fiberglass disk over battery package.
- d) Lift the fiberglass disk off the three bolts and pivot the disk about the purge tube until it is free of the battery.
- e) Slide the battery off the three threaded rods.
- f) Mount the new battery on the three threaded rods; be sure the battery wires line up with the lower disk hole.
- g) Pivot the fiberglass disk back over the battery; replace nuts.
- h) Tie down the battery wires and reconnect J1.

2. Replacing Zinc Anodes. The three zinc anodes (located on the housing, sensor end-cap, and lower cross member) should be replaced as necessary.

3. Anti-Foulant Paint. Clean and repaint the meter with anti-foulant (tri-butyl-tin-fluoride) as required.

4. "O" Rings. "O" rings should be kept clean and slightly greased (Dow Corning No. 4 Compound Silicone Grease or equivalent). "O" rings should be inspected and replaced as required.

5. Replacing External Hardware. Inspect all external hardware and replace with correct replacement parts as required. Note that the sensor end-cap hardware is titanium.

## TROUBLE-SHOOTING

The following section is not an attempt to describe an exact procedure for repairing the ACM-1 but rather a checklist of ideas that might be useful to the trained electrical technician. It is assumed that the person attempting to repair the ACM-1 is familiar with digital and analog electrical circuits and has studied the preceding sections of this manual. Refer to Section 5.3 for adjustment procedures.

### Equipment Required:

1. Voltmeter/Ammeter/Ohmmeter
  2. Oscilloscope
  3. Card Extender
  4. Frequency Counter
  5. Cassette Reader
  6. Capacitance Checker
1. Mechanical Integrity
    - Cards fully seated?
    - Connectors secure?
    - Interconnecting wires secure?
  2. Power
    - Battery Voltage O.K.?
    - Inline battery fuses?
    - Power and timing card fuse?
    - ON/OFF switch O.K.?
    - Regulated power O.K. (see section 2.4)?
    - Current drain O.K. (see section 2.4)?

Note: If current drain is excessive, try to determine where the excessive drain is located. Remove cards one-by-one and recheck drain or check voltage drop on those cards with a series power resistor (measure across the I TEST resistor).

3. Timing (see section 4.4.2)

--Check the power and timing card signals

34 HZ

68 HZ

136 HZ

273 HZ

16384 HZ

32768 HZ

XMT

X, Y CONTROL

X, Y GATE

X, Y RCV

4. Velocity Transducer (see section 4.1.1)

--Transducer capacitance 580 to 650 pf  
for each of four piezo-electric disks?

--Isolation resistance > 2 Mohm?

5. Oscillator Card (see section 4.1.2)

--Verify signals

--Verify oscillator lock; LOOP STATUS = 0 Volts

6. Velocity Interface (see section 4.1.3)

--Verify signals, simulate per section 2.4 or with  
transducer in water.

7. Compass (see section 4.2.1)

--Torroidal winding resistance < 1 ohm?

--Sense winding =  $163 \pm 7$  ohms?

--Pendulum is free?

Note: Do not open compass unless required.  
The compass alignment will be lost  
if the lid is opened. Tilt the com-  
pass and listen for the pendulum to  
hit the stops at about  $30^\circ$ .

8. Compass Electronics (see section 4.2.2)

--Verify signals

9. Signal Processing Card (see section 4.3.1)

--Verify signals

10. Analog-to-Digital Converter Card (see section 4.3.2)

--Verify signals

--Simulate inputs (see section 2.4)

11. Accumulator Card (see section 4.5.1)

--Verify signals

--Simulate inputs (see section 2.4)

12. Thermistor (see section 4.5.2)

--Measure  $T_1$ ; 6K at  $25^\circ\text{C}$  (orange to black)

--Measure  $T_2$ ; 30K at  $-25^\circ\text{C}$  (red to black)

--Verify resistance changes with temperature

Note: Resistance goes down with increased temperature.

13. Time-Temperature Card (see section 4.5.3 & 2.4)

--Simulate thermistor with resistor across  
pins 20 and 24 (thermistor disconnected)

10K represents 28.7 HZ at Pin 27  
or 29.8°C.

20K represents 6.4HZ at Pin 27  
or 4.8°C.

--Verify ACOUSTIC Y and ACOUSTIC X signals with  
the transducer in water.

--Rotate compass and verify heading data change  
(data word or frequency at Pin 13).

--Verify MINUTE signal

--Verify CLOCK SET, CLOCK RESET functions using  
TSDR box or equivalent.

--Verify other signals

14. Memodyne Formatter (see section 4.6.2)

--Verify +12 Volts (switched)

--Verify signals

15. Cassette Recorder (Memodyne) (see Memodyne Manual)

--Verify tape movement

--Verify tape signals

--Read tape

16. Cassette Recorder (Sea Data) (see Sea Data Manual)

--Verify tape movement

--Verify tape signals

--Check Take-up Torque

--Read tape

**SCHEMATICS, COMPONENT LAYOUTS**

1. **OSCILLATOR CARD**
2. **VELOCITY INTERFACE CARD**
3. **COMPASS ELECTRONICS CARD**
4. **SIGNAL PROCESSOR CARD**
5. **ANALOG-TO-DIGITAL CONVERTER CARD**
6. **POWER AND TIMING CARD**
7. **ACCUMULATOR CARD**
8. **TIME AND TEMPERATURE CARD**
9. **MEMODYNE FORMATTER (TYPE II) CARD**

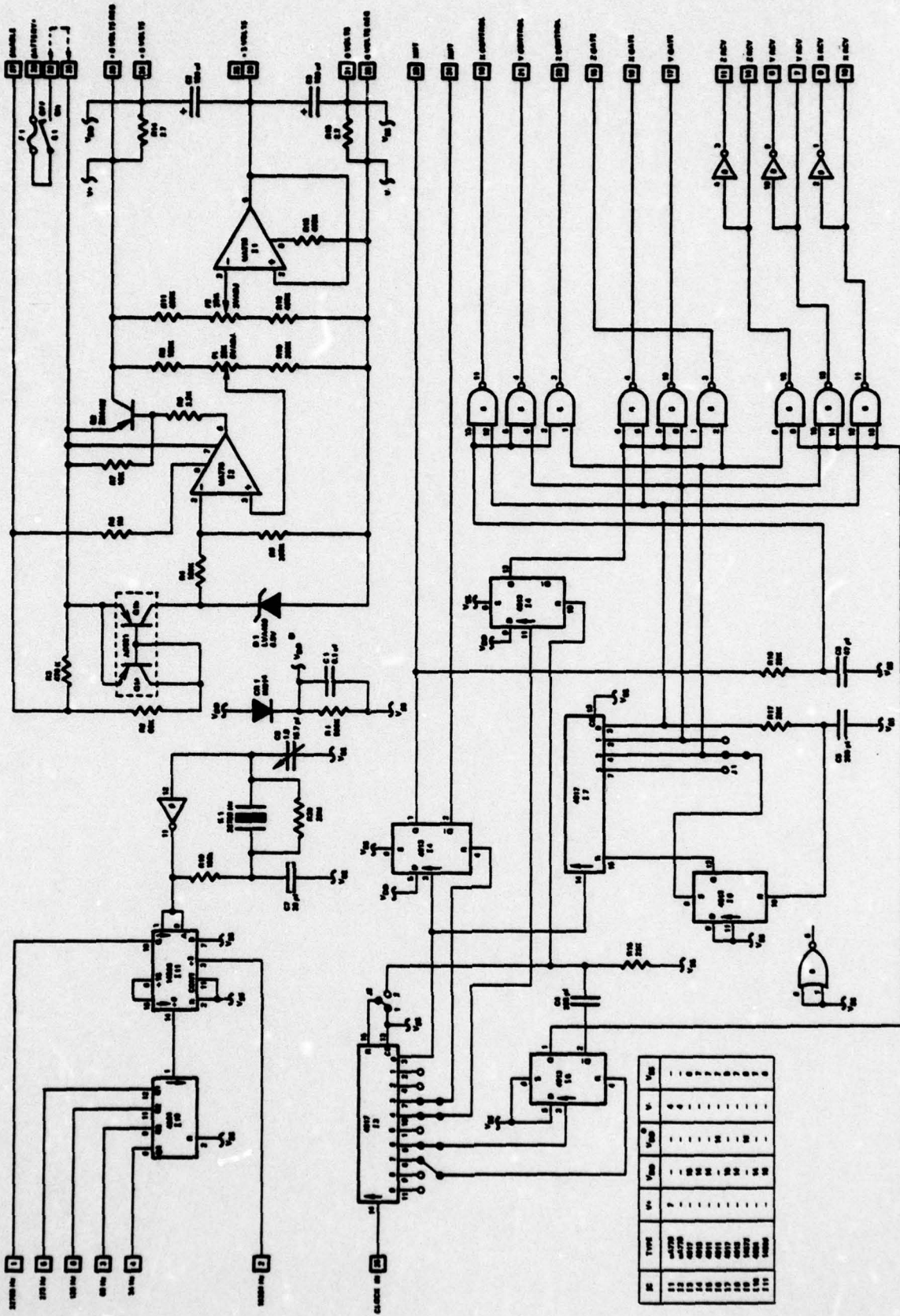

POWER & TIMING (DWG. NO. B20060F)

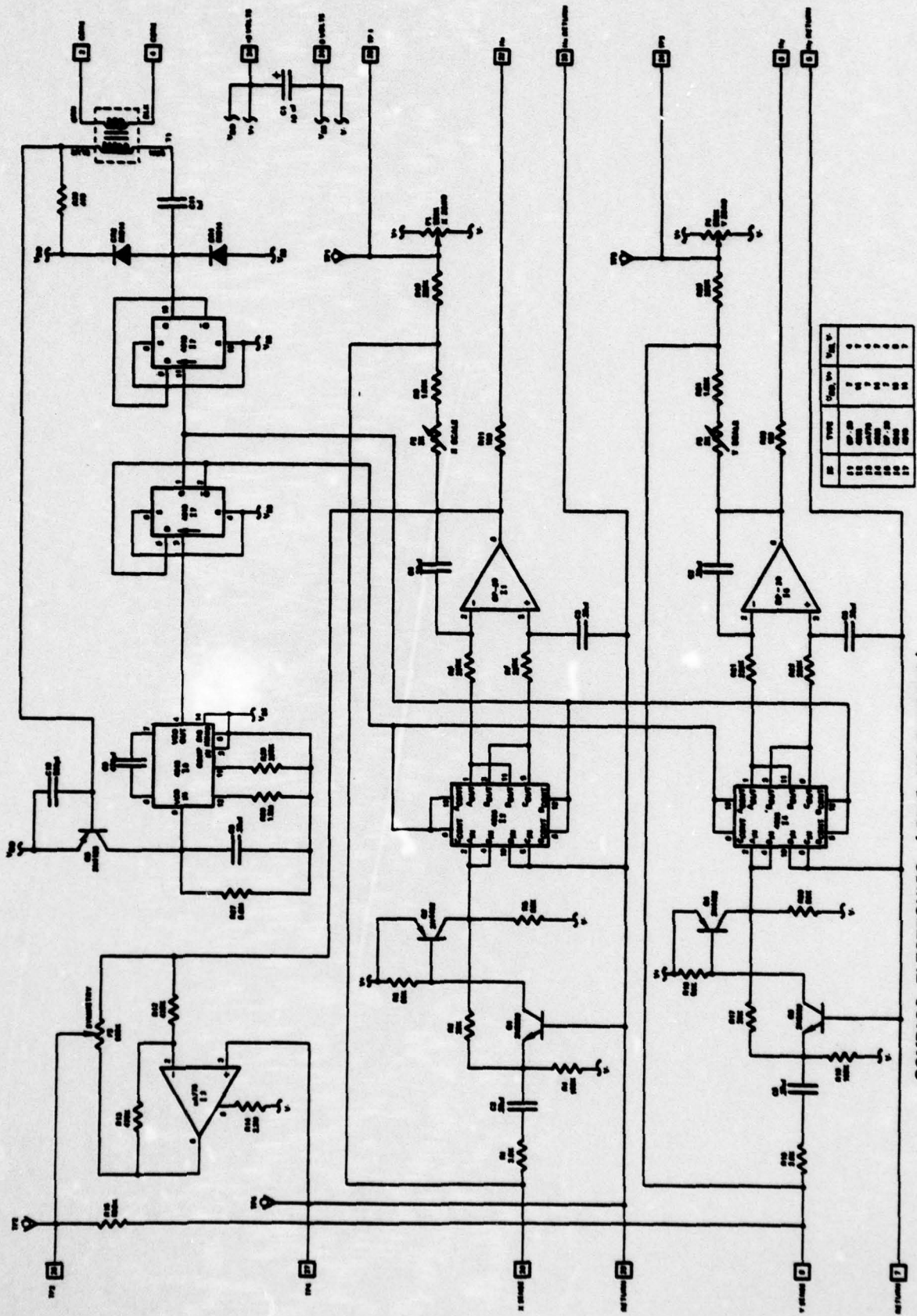

COMPASS ELECTRONICS ( DWG. NO. B20044E )

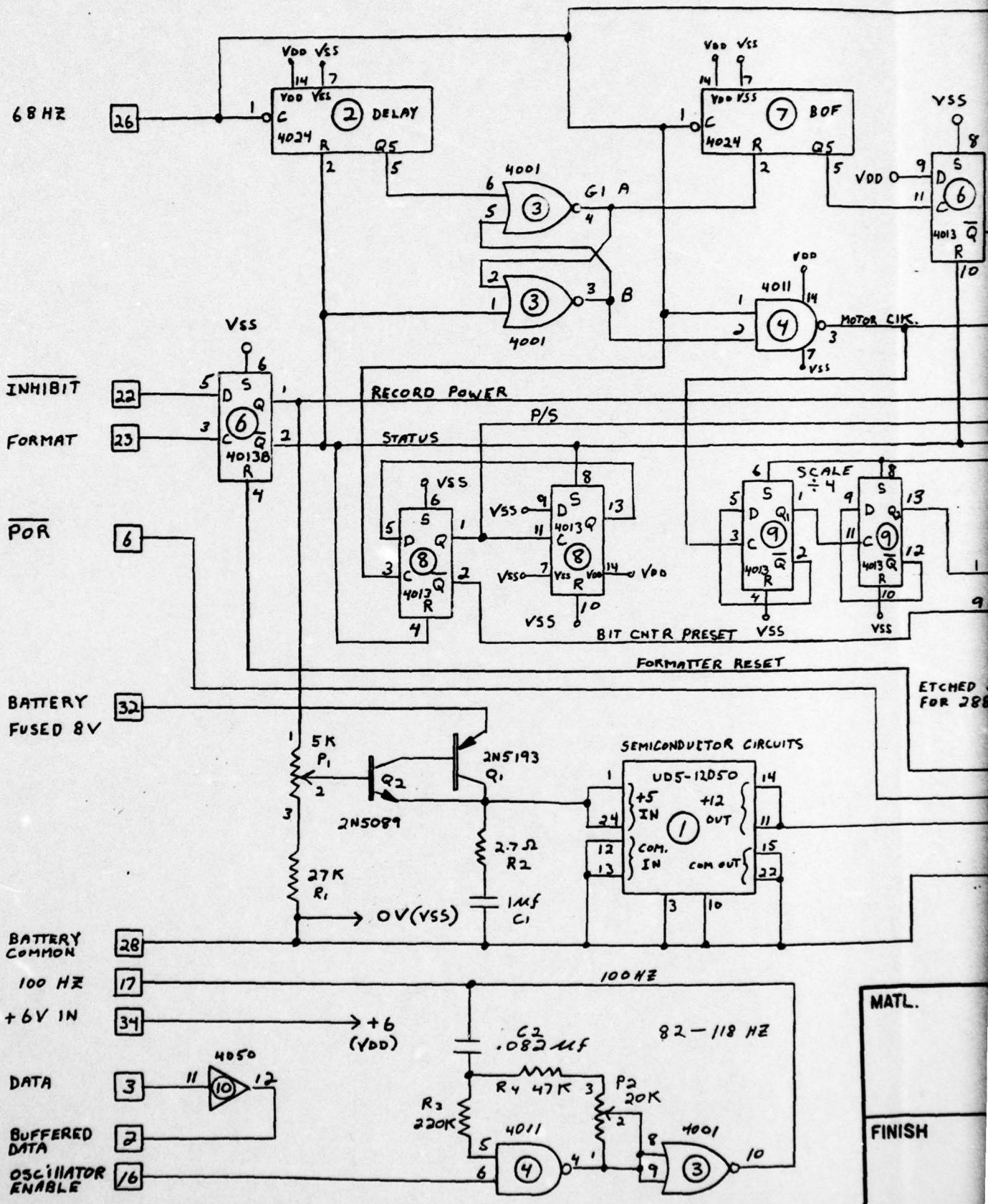

REV.	DESCRIPTION	DATE	APV'L
A	CHANGE R5 FROM 100K TO 1K ECC #21	6 FEB 79	APJ

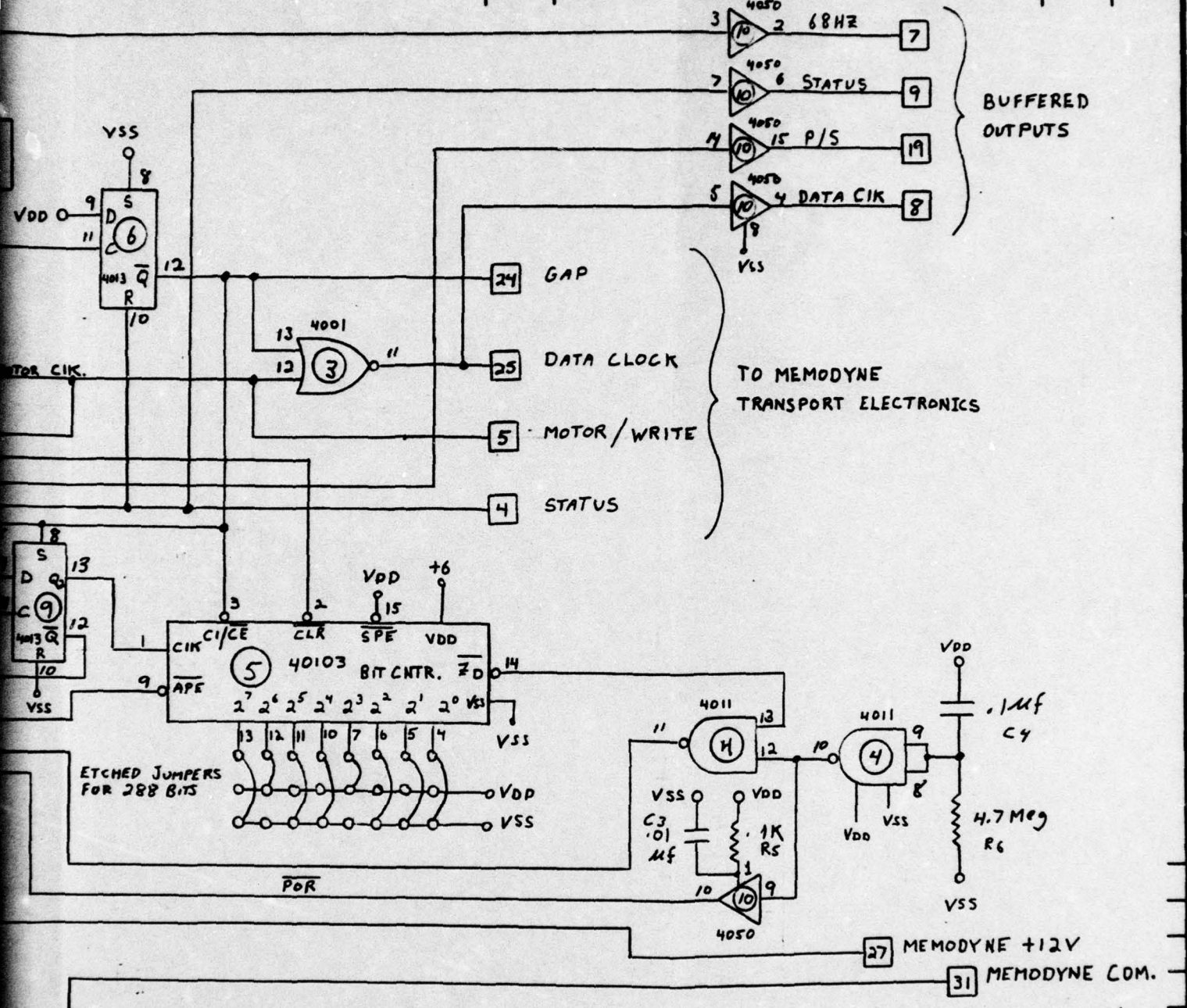

GI	G2	PART NO.	DESCRIPTION	ITEM NO.

MATL.	UNLESS OTHERWISE NOTED DIMENSIONS ARE IN INCHES INCLUDE CHEM. OR PLATED FIN.			<b>NEIL BROWN INSTRUMENT SYSTEMS</b> FALMOUTH, MASS. U.S.A. 02540	
	TOLERANCES				
FINISH	BASIC DIMENSION	DECIMALS		DATE	APPROVED BY
		2 PLACES	3 PLACES	30 MAY 78	
	UNDER 6	±.02	±.005	TITLE	
	6-24 INCL.	±.03	±.010	ACOUSTIC CURRENT METER	
	OVER 24	±.06	±.015	MEMODYNE FORMATTER TYPE II	
COMPL. TOTAL FOR STOCK		ANGLES ±1/2°		MJO	SIZE B
				1512	DRAWING NO. 20284
					REV. A



AD-A070 721

BROWN (NEIL) INSTRUMENT SYSTEMS INC CATAUMET MA  
THREE AXIS ACOUSTIC CURRENT METER.(U)  
MAY 79

F/G 14/2

N00014-75-C-0113

NL

UNCLASSIFIED

3 OF 3

AD  
A070721



END  
DATE  
FILMED  
8-79  
DDC

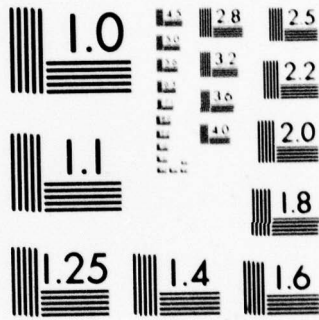

MICROCOPY RESOLUTION TEST CHART  
NATIONAL BUREAU OF STANDARDS 1963-A

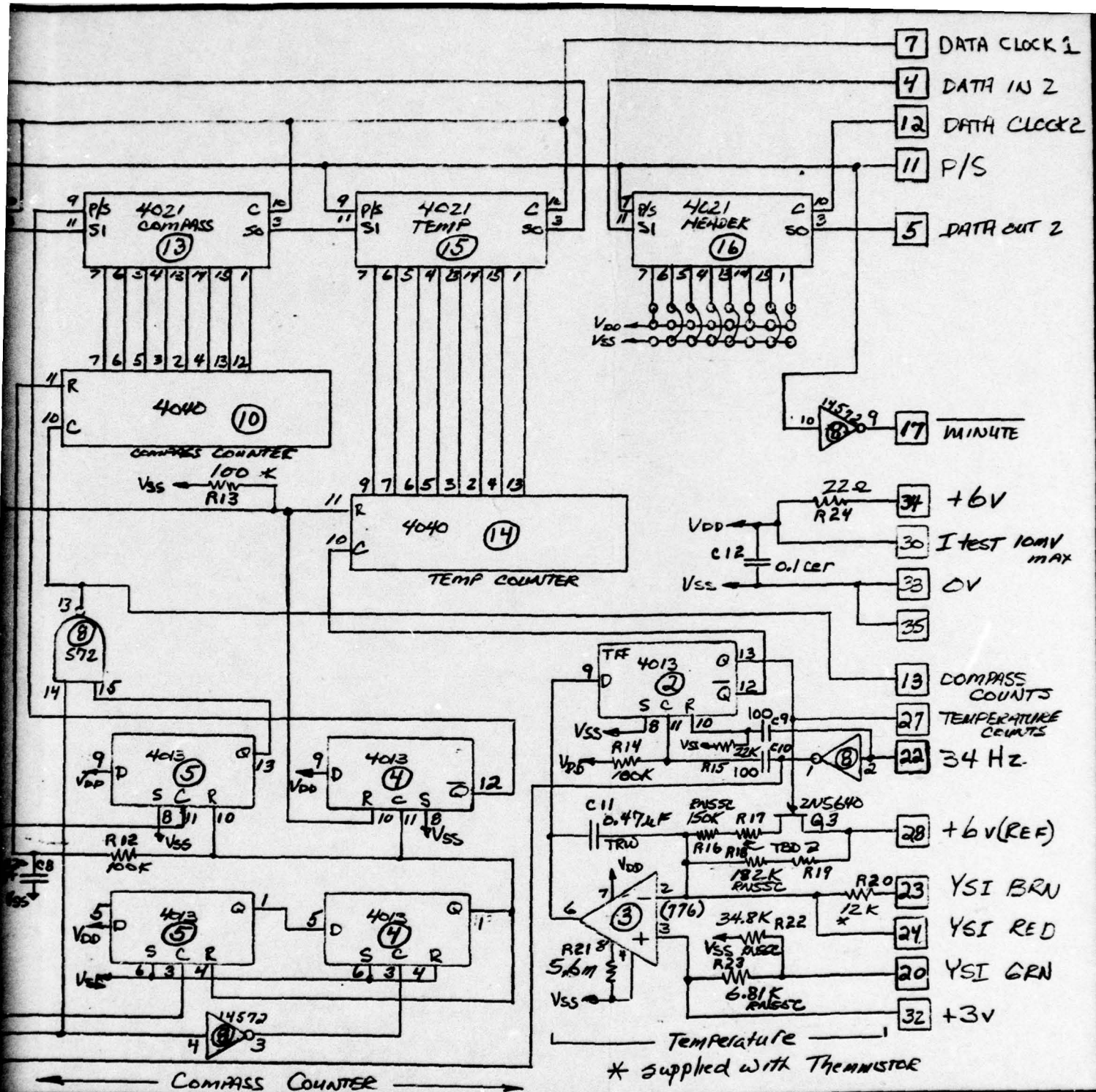

MATERIAL	UNLESS OTHERWISE NOTED DIMENSIONS ARE IN INCHES INCLUDE CHEM. OR PLATED FIN.			NEIL BROWN INSTRUMENT SYSTEMS FALMOUTH, MASS. U.S.A. 02540		DRAWN BY KDL	APPROVED BY
	TOLERANCES						
FINISH	BASIC DIMENSION	DECIMALS		FRACTIONS	DATE	TITLE	
		2 PLACES	3 PLACES		2 DEC 78	ACM-1 TIME - TEMPERATURE	
	UNDER 6	±.02	±.005	±1/64	MJO	SIZE	DRAWING NO.
	6-24 INCL.	±.03	±.010	±1/32	1512	B	20289
OVER 24	±.06	±.015	±1/16				
COMPL. TOTAL FOR STOCK ANGLES ±1/2°							REV. C

SIGN VN 25  
 COUNT VN 26  
 SIGN VE 14  
 COUNT VE 13

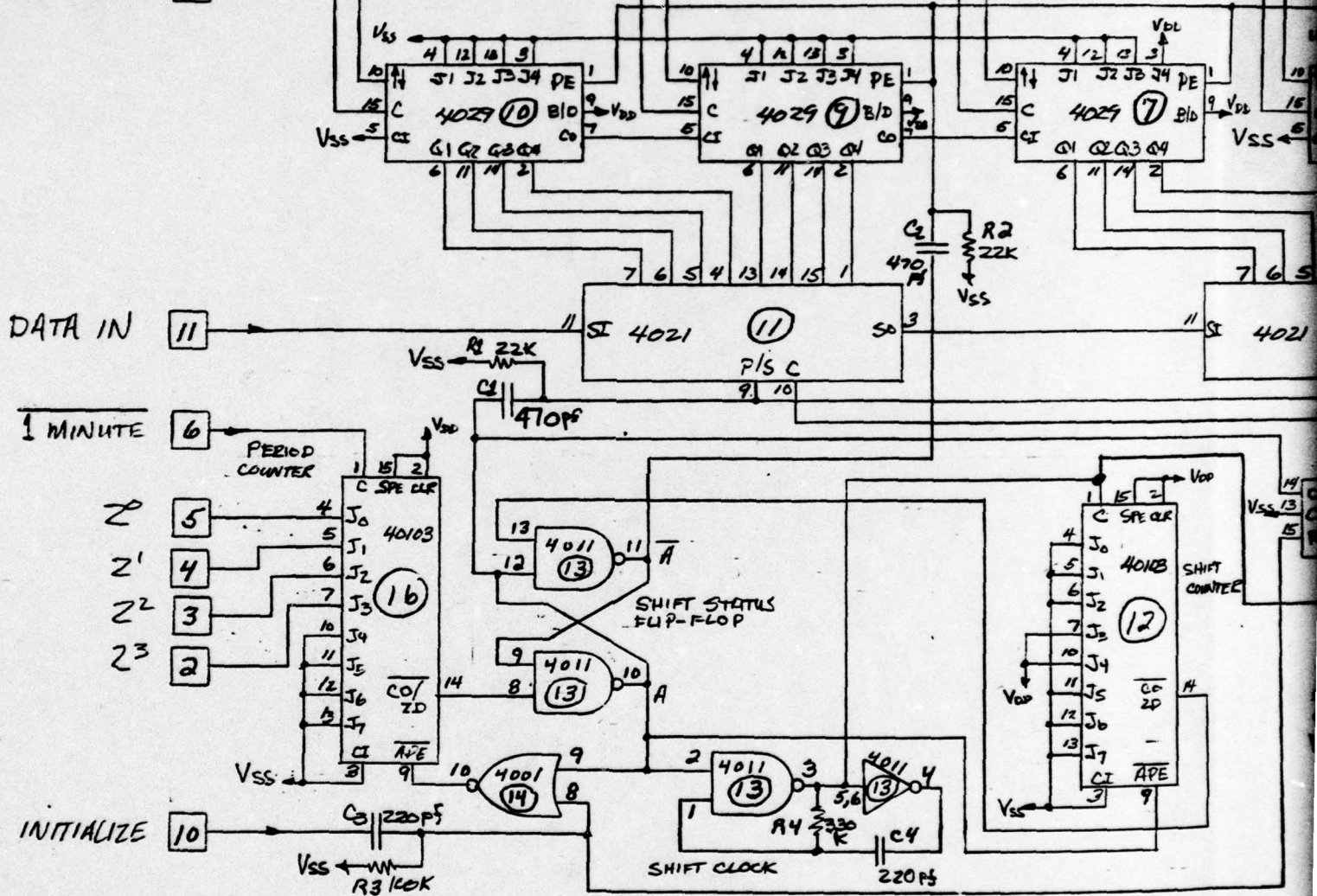

- 1) SHIFT CLOCK MUST GENERATE 24 CLOCKS IN 18MS.  
 $F_{MIN} = 1.33KHz$ . VALUES SHOWN FOR 10KHz NOT.
- 2)  $\frac{1}{2}$  PERIOD OF SHIFT CLOCK MUST BE  $> R_{CL}$ .
- 3) INITIALIZE SETS SCAN TO "C" AND PERIOD COUNTER TO "N".  
 1<sup>ST</sup> FORMAT OCCURS N MINUTES AFTER INITIALIZE.  
 SUBSEQUENT FORMATS OCCUR AT 10N MINUTE INTERVALS

MATL.  
 FINISH



LTR	
B	CHANGED ICI IC9; 2 ADDED

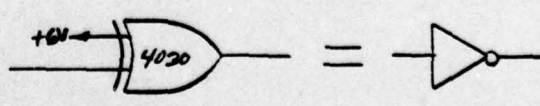
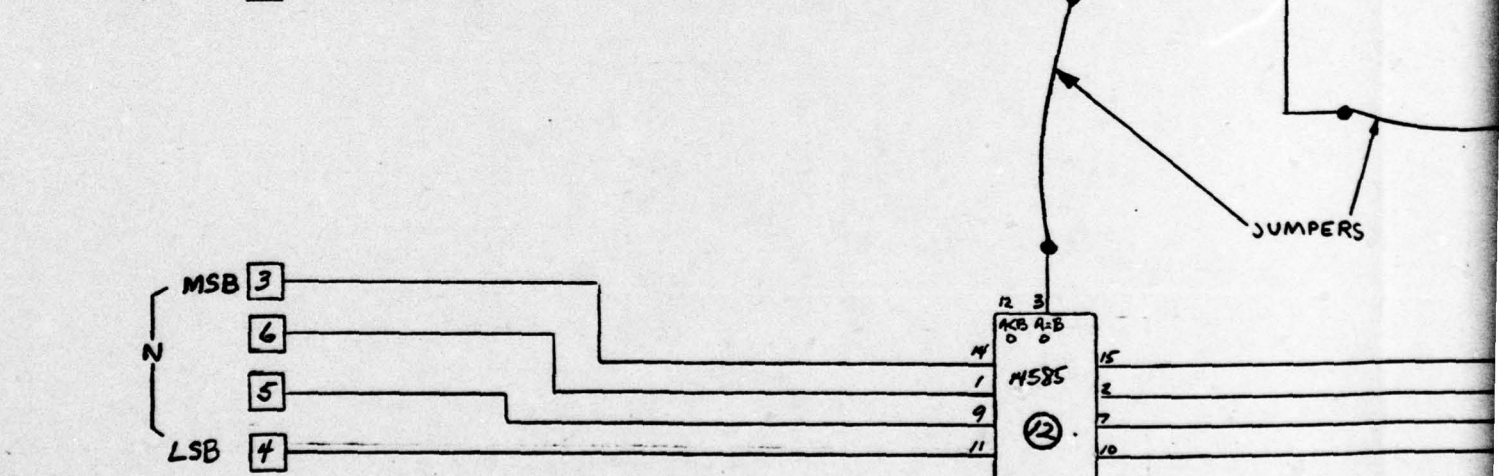
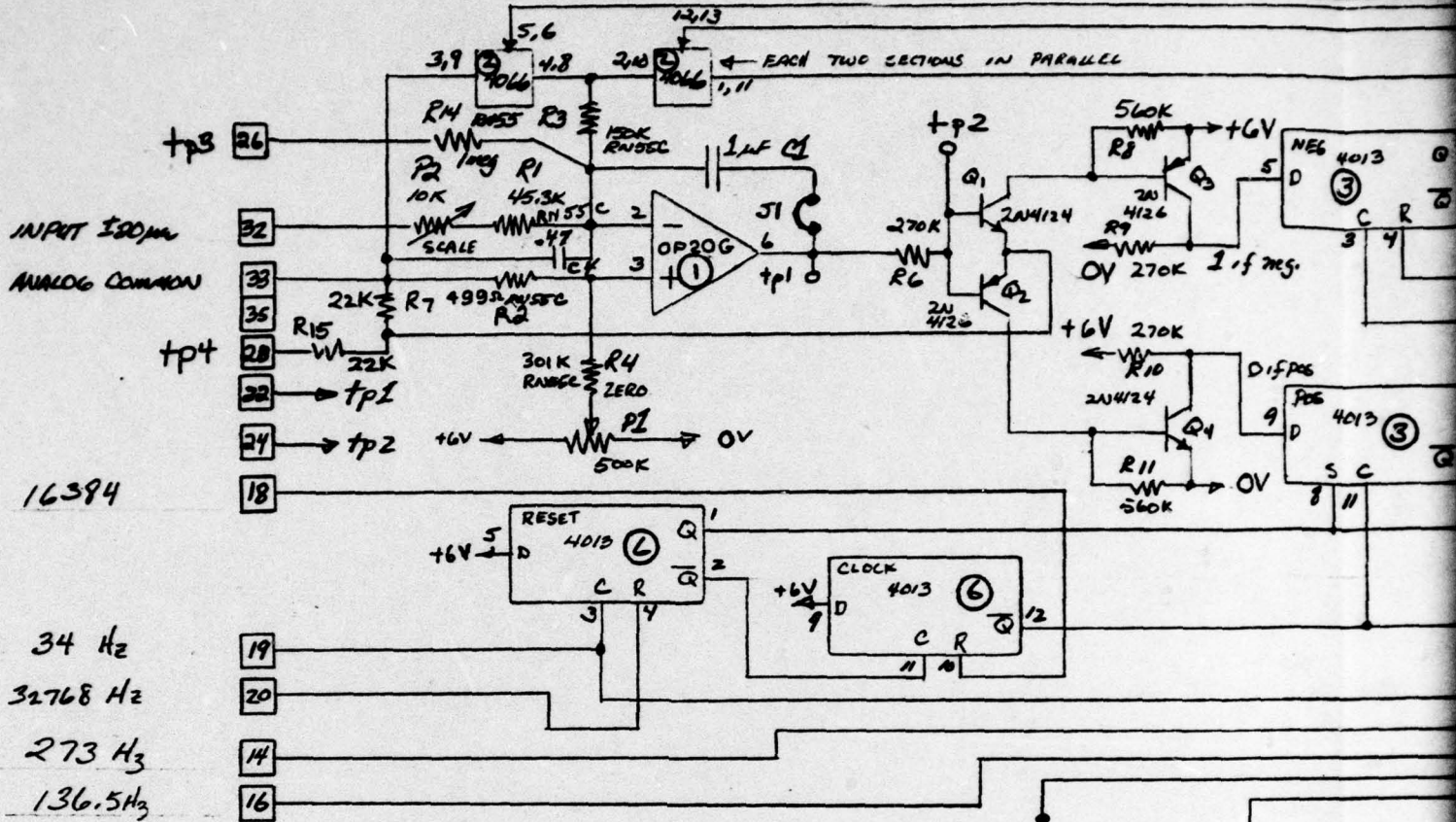

MATL.	
FINISH	

C	DELETE RS & C3	3/13/79	RJR
REV	DESCRIPTION	DATE	APVL

DESCRIPTION

DATE APVL

CHANGED IC1 FROM U1776TC; R2 FROM 2K; REMOVED IC8  
 IC9; 2 ADDED JUMPERS, CHANGED +6V FROM +3V & 0V FROM 0V  
 J.P. 11/6

22/11/79 K.D.L.

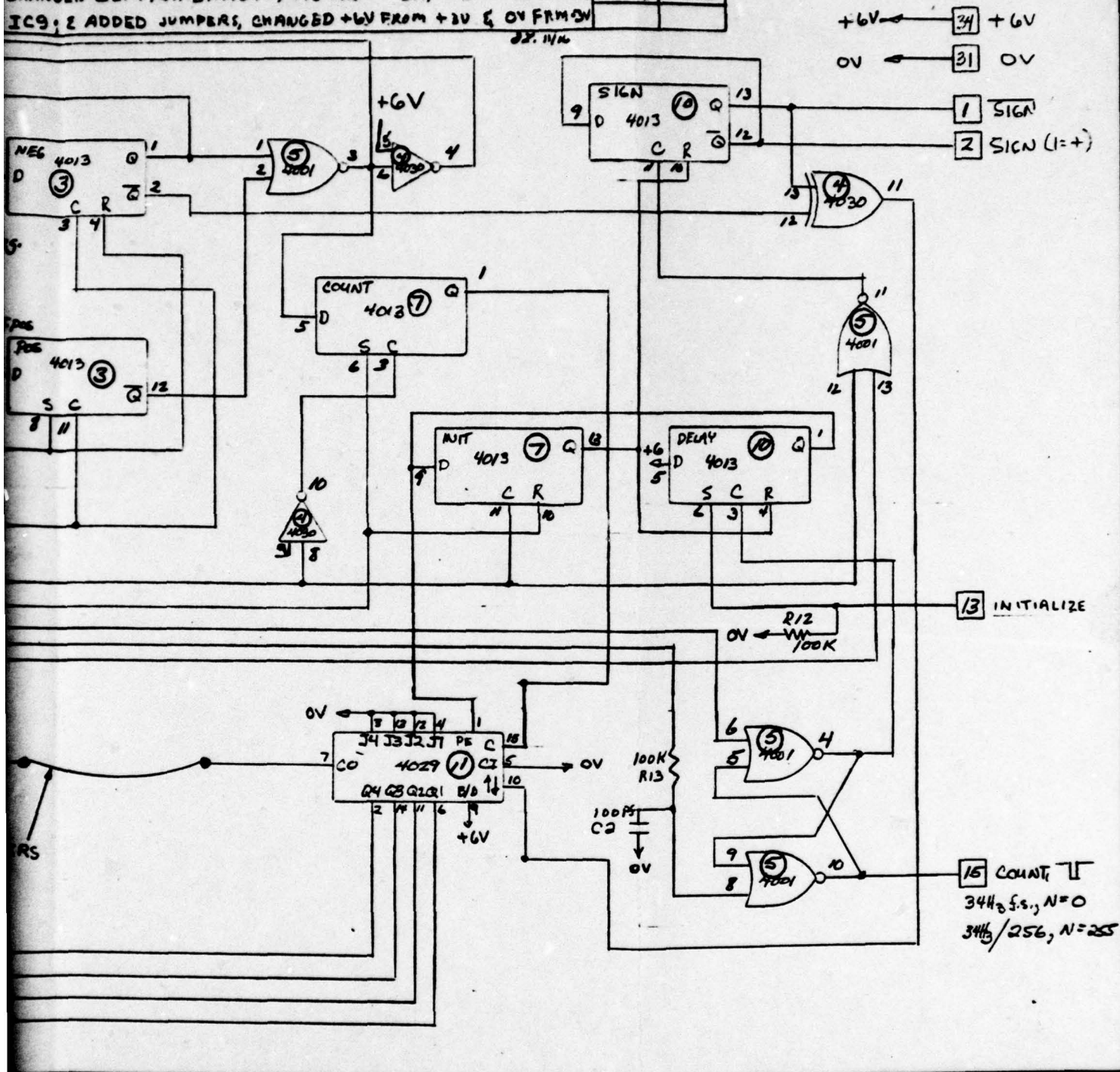

+6V ← [24] +6V  
 0V ← [31] 0V  
 [1] SIGN  
 [2] SIGN (I=+)

[3] INITIALIZE

[15] COUNT,  $\square$   
 34Hz f.s., N=0  
 34Hz/256, N=255

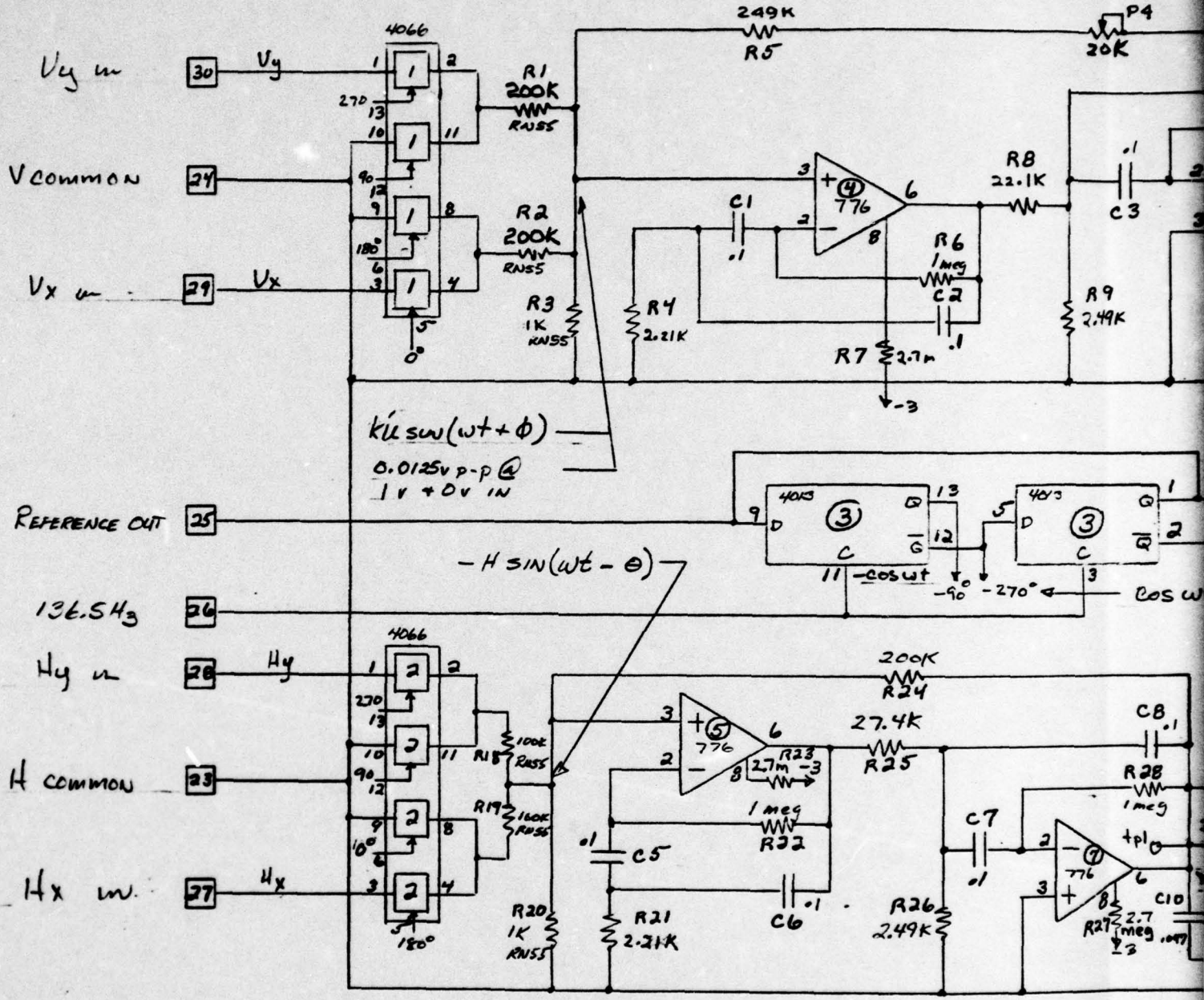

$kL \sin(\omega t + \phi)$   
 0.0125V p-p @  
 1V + DV IN

$-H \sin(\omega t - \theta)$

MATL.
FINISH

ASSY C10701B

LTR	DESCRIPTION	DATE	APV/L
A	CH'NGED ICB FROM 776, ADDED JUMP & DEL. R'S 15-17 + PI	18 Dec 78	KCL
B	R1 & R2 CHANGED TO 200K FROM 100K, Connection to 4 KLL SW(WT + $\phi$ )	9 JAN 79	R.R

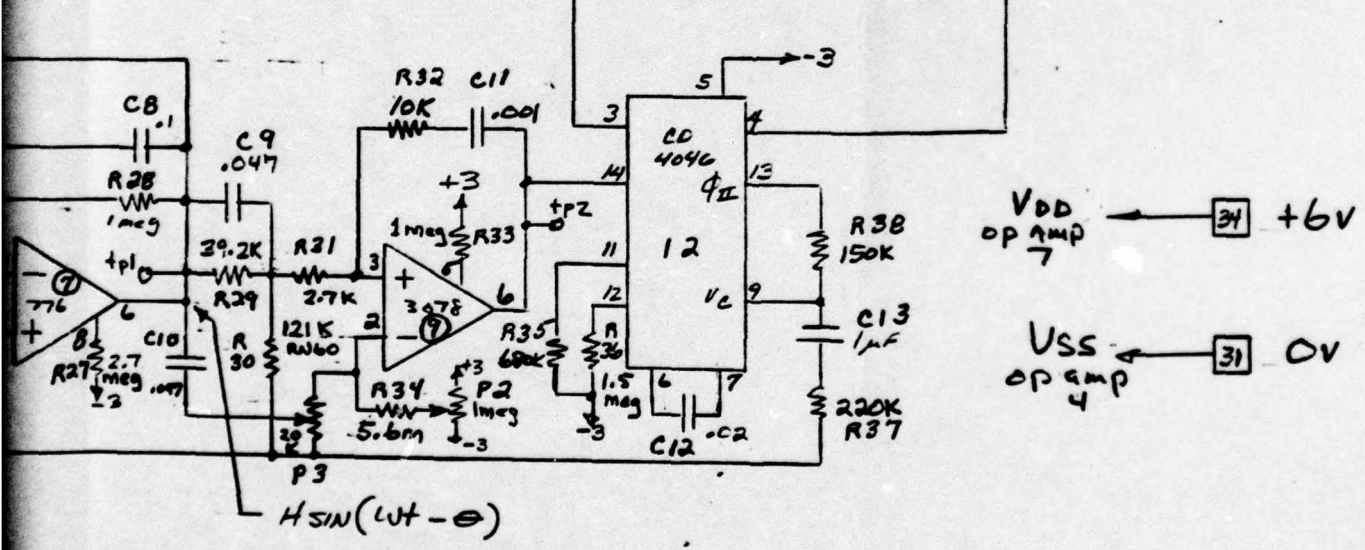
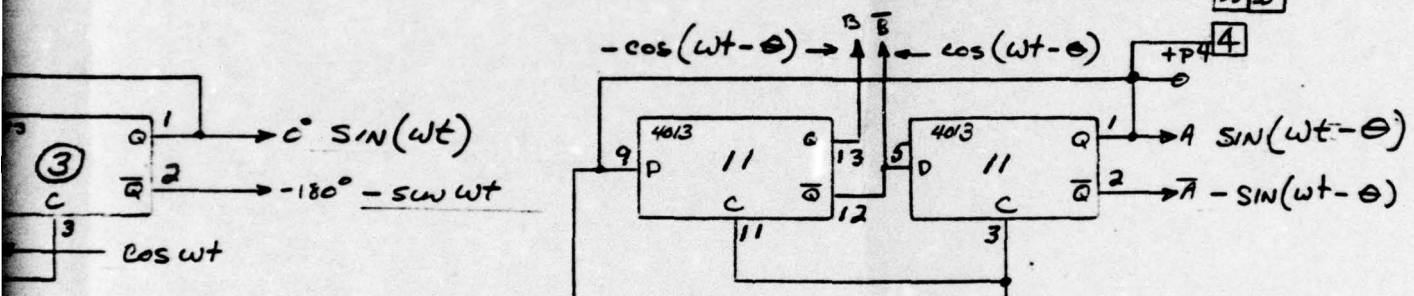
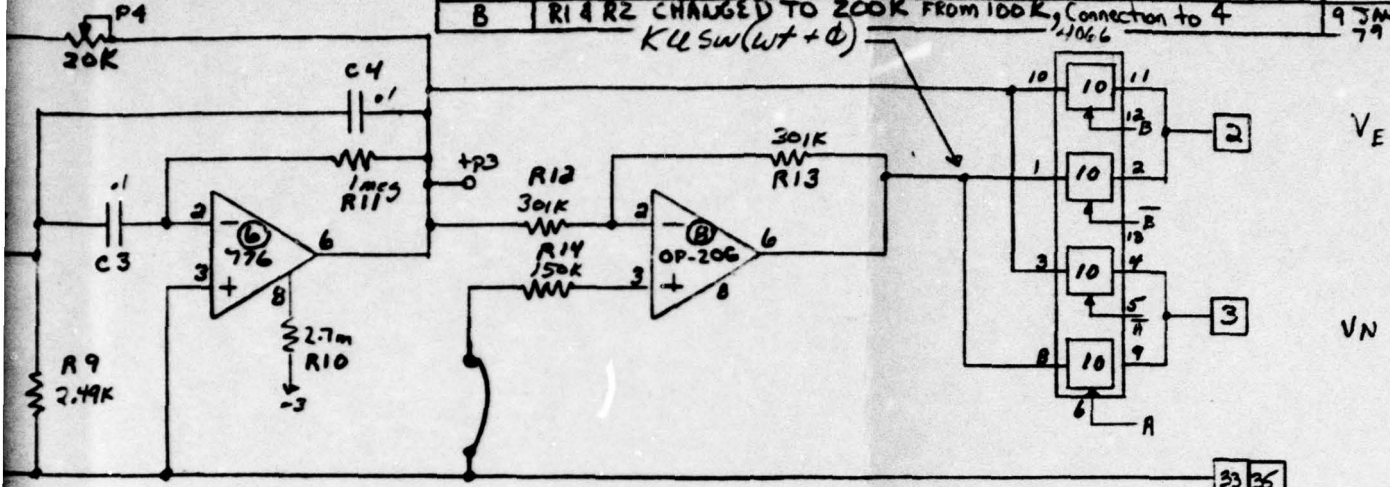

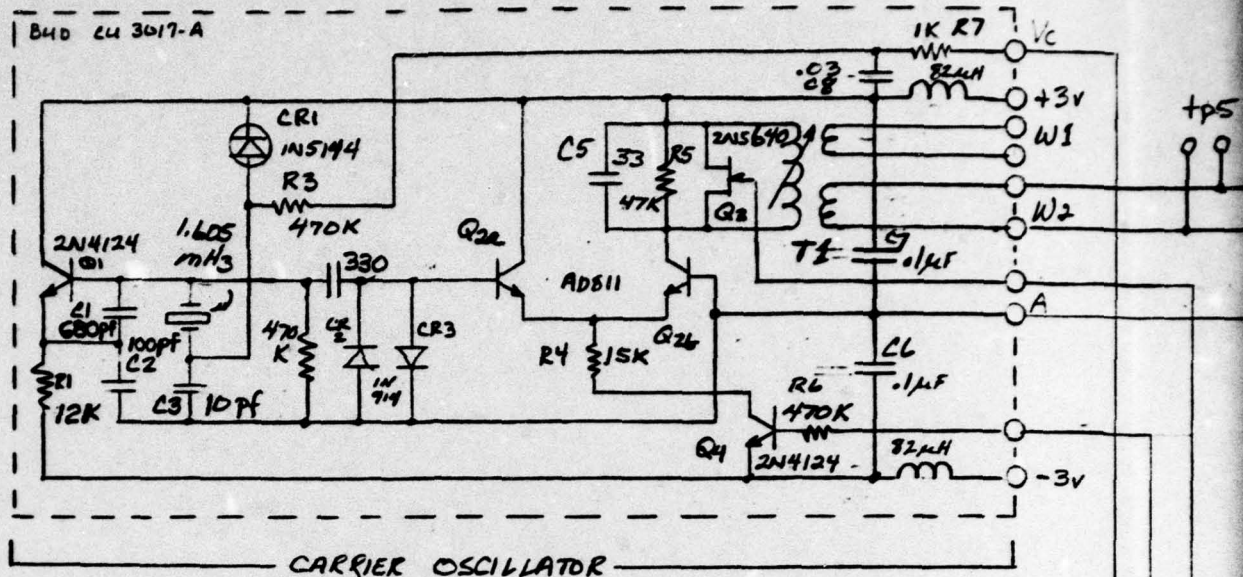

XMT 8

XMT 9

34Hz REF

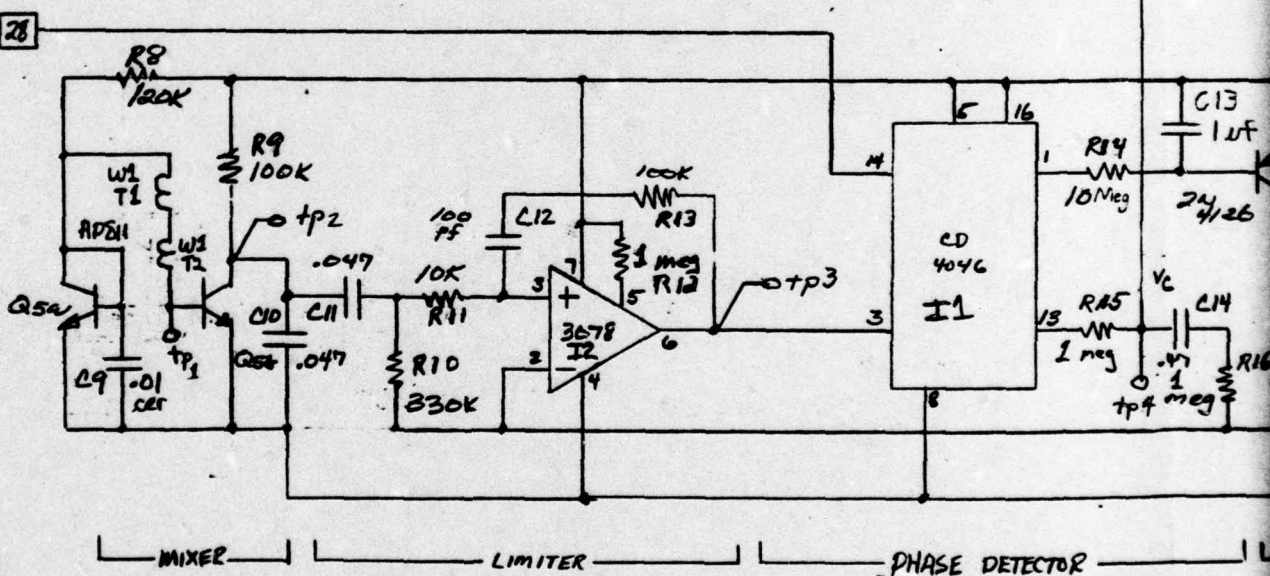

MATL.	
FINISH	
E	R20 CHANGED FROM 22K
A	SEE ECO #002 E #003
REV	DESCRIPTION
3/13/79	RM
9/21/78	KDL
DATE	APVL

TRANSFORMER DRIVERS

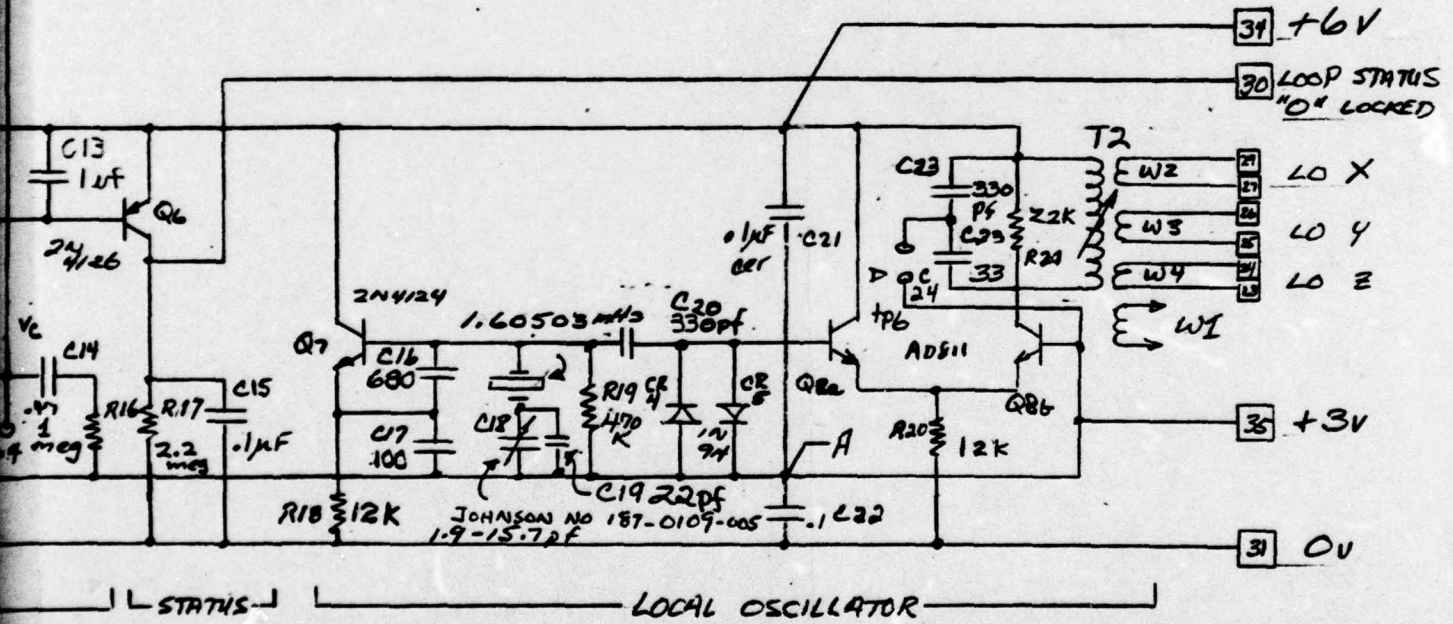
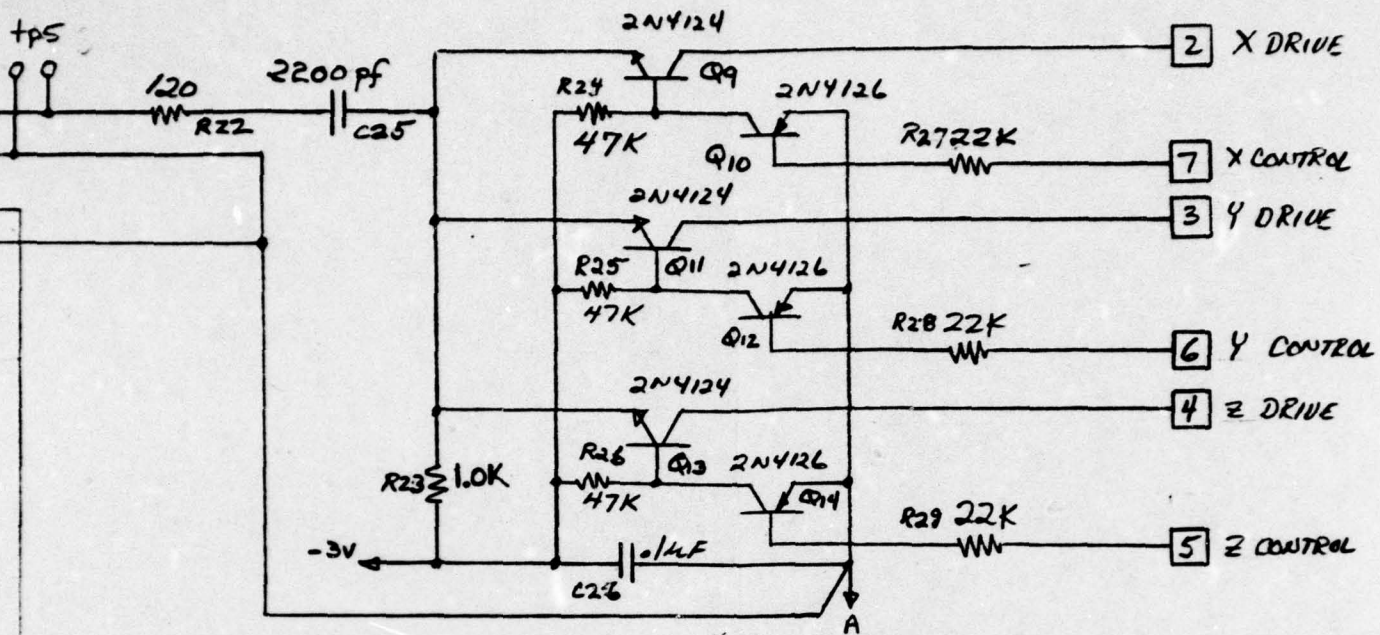

UNLESS OTHERWISE NOTED DIMENSIONS ARE IN INCHES INCLUDE CHEM. OR PLATED FIN.		<b>NEIL BROWN INSTRUMENT SYSTEMS</b> FALMOUTH, MASS. U.S.A. 02540			
TOLERANCES			SCALE	DRAWN BY	APPROVED BY
BASIC DIMENSION	DECIMALS		DATE 12 AUG 1977	KDL	
	2 PLACES	3 PLACES			
UNDER 6	±.02	±.005	TITLE 1.6 MHz VELOCIMETER OSCILLATORS		
6-24 INCL.	±.03	±.010			
OVER 24	±.06	±.015			
COML. TOTAL FOR STOCK ANGLES ±1/2°			MJO	SIZE B	DRAWING NO. 20058
					REV E

2

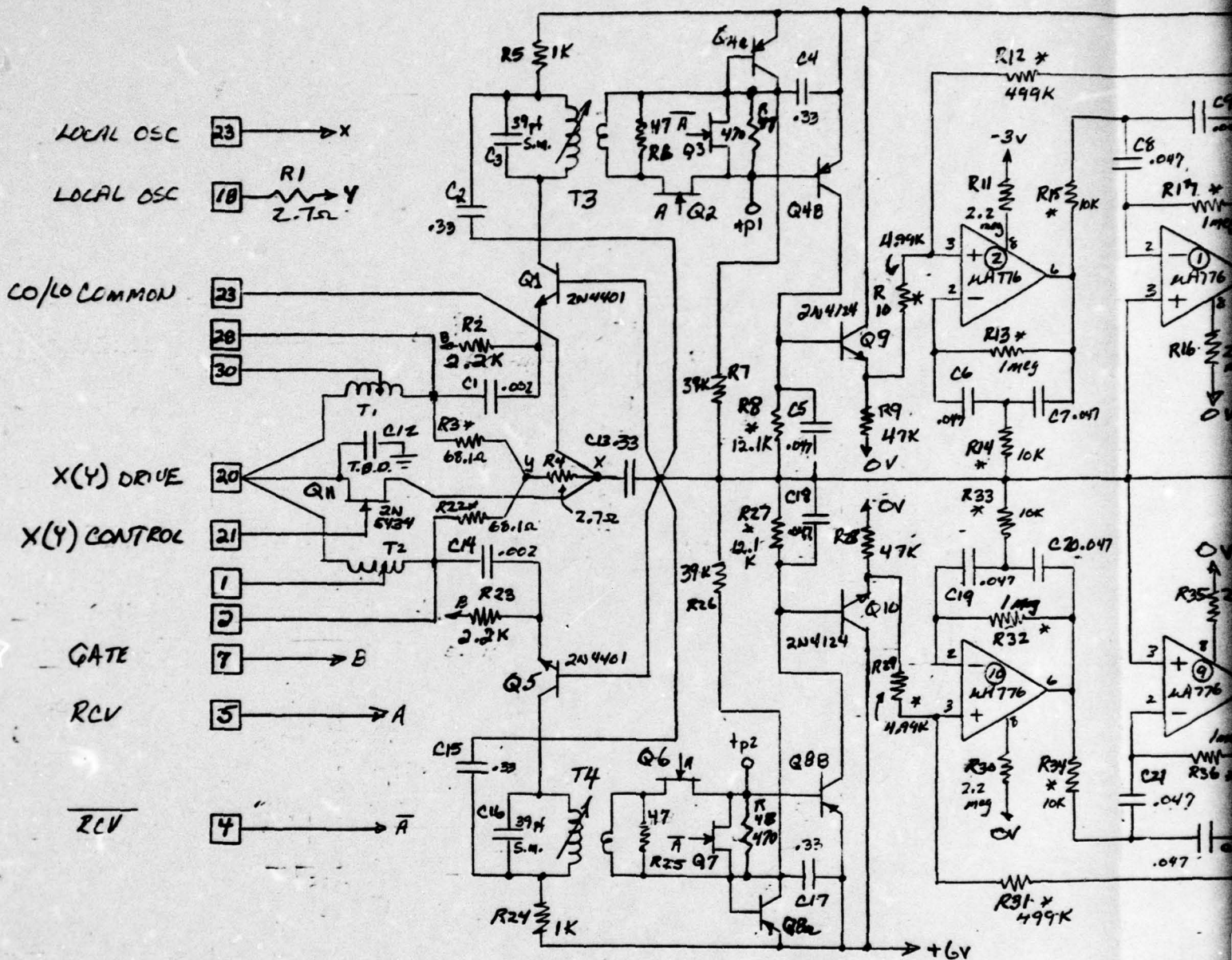

MATL.
FINISH

REV	DESCRIPTION	DATE	APPL
F	CHANGED FROM 715KΩ	J. 7. 11/51	KDL
G	Gen Changes 17 Dec 76	KL	

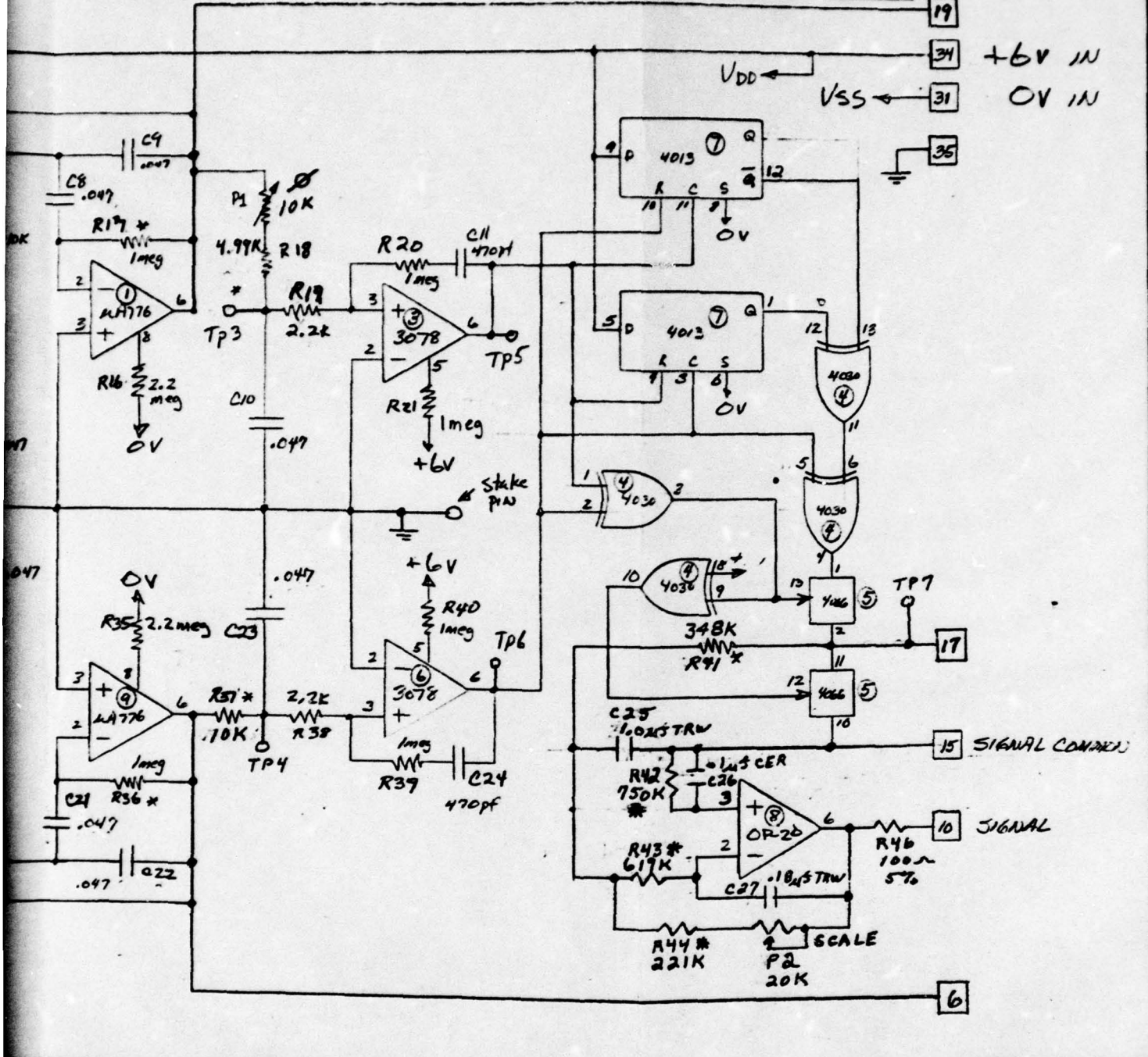

ATL.	UNLESS OTHERWISE NOTED DIMENSIONS ARE IN INCHES INCLUDE CHEM. OR PLATED FIN.			NEIL BROWN INSTRUMENT SYSTEMS FALMOUTH, MASS. U.S.A. 02540			
	TOLERANCES					SCALE	DRAWN BY KDL
FINISH	BASIC DIMENSION	DECIMALS		FRACTIONS	DATE / MARCH 1977	TITLE Velocity Interface X,Y ACM Bd. 01-02	
		2 PLACES	3 PLACES				
	UNDER 6	±.02	±.005	±1/64			
	6-24 INCL.	±.03	±.010	±1/32			
	OVER 24	±.06	±.015	±1/16			
COML. TOTAL FOR STOCK ANGLES ±1/2°				MJO 1002	SIZE B	DRAWING NO. 20049	REV G

## VELOCITY INTERFACE CARD

CIRCUIT BOARD ASSEMBLY #C10277-G2, Rev H

### Capacitors

C1 .0022uf, 50V 10% Miniature Ceramic  
 C2 .33uf 10% Miniature Ceramic  
 C3 39PF Silver Mica, CM05  
 C4 .33uf 10% Miniature Ceramic  
 C5 .047uf Metallized Polycarbonate  
 C6 .047uf Metallized Polycarbonate  
 C7 .047uf Metallized Polycarbonate  
 C8 .047uf Metallized Polycarbonate  
 C9 .047uf Metallized Polycarbonate  
 C10 .047uf Metallized Polycarbonate  
 C11 470PF Silver Mica, CM05  
 C12 not used  
 C13 .33uf 10% Miniature Ceramic  
 C14 .0022uf, 50V 10% Miniature Ceramic  
 C15 .33uf 10% Miniature Ceramic  
 C16 39PF Silver Mica, CM05  
 C17 .33uf 10% Miniature Ceramic  
 C18 .047uf Metallized Polycarbonate  
 C19 .047uf Metallized Polycarbonate  
 C20 .047uf Metallized Polycarbonate  
 C21 .047uf Metallized Polycarbonate  
 C22 .047uf Metallized Polycarbonate  
 C23 .047uf Metallized Polycarbonate  
 C24 470PF Silver Mica, CM05  
 C25 1uf, 50V Metallized Polycarbonate  
 C26 .1uf 10% Miniature Ceramic  
 C27 .18uf, 50V Metallized Polycarbonate

### Connector

1 7022-035-000-001 Elco

### Printed Circuit Board

1 C30019 Rev B NBIS

### Terminal

1 140-1785-02-01-00

### Potentiometers

P1 10K ohm 20 Turn Trimmer  
 P2 20K ohm 20 Turn Trimmer

### Resistors

R1 2.7 ohm 1/4W Carbon 5%  
 R2 2.2K ohm 1/4W Carbon 5%  
 R3 68.1 ohm RN55C Metal Film 1%  
 R4 2.7 ohm 1/4W Carbon 5%  
 R5 1K ohm 1/4W Carbon 5%  
 R6 TBD 1/4W Carbon 5%  
 R7 39K ohm 1/4W Carbon 5%  
 R8 12.1K ohm RN55C Metal Film 1%  
 R9 47K ohm 1/4W Carbon 5%  
 R10 4.99K ohm RN55C Metal Film 1%  
 R11 2.2M ohm 1/4W Carbon 5%  
 R12 499K ohm RN55C Metal Film 1%  
 R13 1M ohm RN55C Metal Film 1%  
 R14 10K ohm RN55C Metal Film 1%  
 R15 10K ohm RN55C Metal Film 1%  
 R16 2.2M ohm 1/4W Carbon 5%  
 R17 1M ohm RN55C Metal Film 1%  
 R18 4.99K ohm RN55C Metal Film 1%  
 R19 2.2K ohm 1/4W Carbon 5%  
 R20 1M ohm 1/4W Carbon 5%  
 R21 1M ohm 1/4W Carbon 5%  
 R22 68.1 ohm RN55C Metal Film 1%  
 R23 2.2K ohm 1/4W Carbon 5%  
 R24 1K ohm RN55C Metal Film 1%  
 R25 TBD 1/4W Carbon 5%  
 R26 39K ohm 1/4W Carbon 5%  
 R27 12.1K ohm RN55C Metal Film 1%  
 R28 47K ohm 1/4W Carbon 5%  
 R29 4.99K ohm RN55C Metal Film 1%  
 R30 2.2M ohm 1/4W Carbon 5%  
 R31 499K ohm RN55C Metal Film 1%  
 R32 1M ohm RN55C Metal Film 1%  
 R33 10K ohm RN55C Metal Film 1%  
 R34 10K ohm RN55C Metal Film 1%  
 R35 2.2M ohm 1/4W Carbon 5%  
 R36 1M ohm RN55C Metal Film 1%  
 R37 10K ohm RN55C Metal Film 1%  
 R38 2.2K ohm 1/4W Carbon 5%  
 R39 1M ohm 1/4W Carbon 5%  
 R40 1M ohm 1/4W Carbon 5%  
 R41 348K ohm RN55C Metal Film 1%  
 R42 750K ohm RN55C Metal Film 1%  
 R43 619K ohm RN55C Metal Film 1%  
 R44 221K ohm RN55C Metal Film 1%  
 R45 not used  
 R46 100 ohm 1/4W Carbon 5%  
 R47 470 ohm 1/4W Carbon 5%  
 R48 470 ohm 1/4W Carbon 5%

VELOCITY INTERFACE CARD (Cont.)

CIRCUIT BOARD ASSEMBLY #C10277-G2, Rev H

Integrated Circuits

I1	UA776ATC Op Amp
I2	UA776ATC Op Amp
I3	CA3078S Amplifier
I4	CD4030AE - Quad Exclusive - OR
I5	CD4066AE Quad Switch
I6	CA3078S Amplifier
I7	CD4013AE Dual Flip-Flop
I8	OP20-GP Op Amp
I9	UA776ATC Op Amp
I10	UA776ATC Op Amp

Transistors

Q1	2N4401
Q2	2N5640
Q3	2N5640
Q4	AD821
Q5	2N4401
Q6	2N5640
Q7	2N5640
Q8	AD821
Q9	2N4124
Q10	2N4124
Q11	2N5434

Transformers

T3,T4	B10510 NBIS
T2,T1	B10509 NBIS

## PARTS LIST (ELECTRICAL)

1. OSCILLATOR CARD
2. VELOCITY INTERFACE CARD
3. COMPASS ELECTRONICS CARD
4. SIGNAL PROCESSOR CARD
5. ANALOG-TO-DIGITAL CONVERTER CARD
6. POWER AND TIMING CARD
7. ACCUMULATOR CARD
8. TIME AND TEMPERATURE CARD
9. MEMODYNE FORMATTER (TYPE II) CARD

## OSCILLATOR CARD

CIRCUIT BOARD ASSEMBLY #C10405-G2, REV G

### Capacitors

\*C1 680PF Silver Mica, CM05  
 \*C2 100PF Silver Mica, CM05  
 \*C3 10PF Silver Mica, CM05  
 \*C4 330PF Silver Mica, CM05  
 \*C5 33PF Silver Mica, CM05  
 \*C6 .1uf 10% Miniature Ceramic  
 \*C7 .1uf 10% Miniature Ceramic  
 \*C8 .033uf 10% Miniature Ceramic  
 C9 .01uf 10% Miniature Ceramic  
 C10 .047uf Metallized Polycarbonate  
 C11 .047uf 10% Metallized Ceramic  
 C12 100PF Silver Mica, CM05  
 C13 1uf 10% Miniature Ceramic  
 C14 .47uf Metallized Polycarbonate  
 C15 .1uf 10% Miniature Ceramic  
 C16 680PF Silver Mica, CM05  
 C17 100PF Silver Mica, CM05  
 C18 1.9 - 15.7PF Trimmer  
 C19 22PF Silver Mica, CM05  
 C20 330PF Silver Mica, CM05  
 C21 .1uf 10% Miniature Ceramic  
 C22 .1uf 10% Miniature Ceramic  
 C23 330PF Silver Mica, CM05  
 C24 33PF Silver Mica, CM05  
 C25 .0022uf 10% Miniature Ceramic  
 C26 .1uf 10% Miniature Ceramic

### Integrated Circuit

I1 CD4046AE Phase-Locked Loop VCO  
 I2 CD3078S Amplifier

### Crystals

\*K1 1.605 mHz  
 K2 1.605 mHz

### Inductors

\*L1 82uh Choke  
 \*L2 82uh Choke

### Resistors

\*R1 12K ohm 1/4W Carbon 5%  
 \*R2 470K ohm 1/4W Carbon 5%  
 \*R3 470K ohm 1/4W Carbon 5%  
 \*R4 15K ohm 1/4W Carbon 5%  
 \*R5 47K ohm 1/4W Carbon 5%  
 \*R6 470K ohm 1/4W Carbon 5%  
 \*R7 1K ohm 1/4W Carbon 5%  
 R8 120K ohm 1/4W Carbon 5%  
 R9 100K ohm 1/4W Carbon 5%  
 R10 330K ohm 1/4W Carbon 5%  
 R11 10K ohm 1/4W Carbon 5%  
 R12 1M ohm 1/4W Carbon 5%  
 R13 100K ohm 1/4W Carbon 5%  
 R14 10M ohm 1/4W Carbon 5%  
 R15 1M ohm 1/4W Carbon 5%  
 R16 1M ohm 1/4W Carbon 5%  
 R17 2.2M ohm 1/4W Carbon 5%  
 R18 12K ohm 1/4W Carbon 5%  
 R19 470K ohm 1/4W Carbon 5%  
 R20 12K ohm 1/4W Carbon 5%  
 R21 22K ohm 1/4W Carbon 5%  
 R22 120 ohm 1/4W Carbon 5%  
 R23 1K ohm 1/4W Carbon 5%  
 R24 47K ohm 1/4W Carbon 5%  
 R25 47K ohm 1/4W Carbon 5%  
 R26 47K ohm 1/4W Carbon 5%  
 R27 22K ohm 1/4W Carbon 5%  
 R28 22K ohm 1/4W Carbon 5%  
 R29 22K ohm 1/4W Carbon 5%

### Printed Circuit Board

1 C30021 NBIS  
 \*1 B30022 REV A NBIS

### Diodes

\*CR1 1N5144  
 \*CR2 1N914  
 \*CR3 1N914  
 CR4 1N914  
 CR5 1N914

OSCILLATOR CARD (CONT.)

CIRCUIT BOARD ASSEMBLY #C10405-G2, REV G

Transistors

*Q1	2N4124
*Q2	AD811
*Q3	2N5640
*Q4	2N4124
Q5	AD811
Q6	2N4126
Q7	2N4124
Q8	AD811
Q9	2N4124
Q10	2N4126
Q11	2N4124
Q12	2N4126
Q13	2N4124
Q14	2N4126

Carrier Board

1 B10404 Rev C NBIS

Transformers

*T1	B10825 Rev A NBIS
T2	B10826 Rev A NBIS

Terminals

1	Gnd 140-1785 Cambion
TP5	65500-136 Berg
TP6	65500-136 Berg

Hardware

2	Washers, Flat 4-40
4	Washers, Int. Star 4-40
6	Screws, Pan Head 4-40x1/4"
4	Spacers, Threaded 1/4"4-40

\*Part of assembly #B10344-G1, Rev C

COMPASS ELECTRONICS CARD

CIRCUIT BOARD ASSEMBLY #C10262-G2, PEV E

Capacitors

C1 10uf 20V Tantalum, 150D  
 C2 .33uf 10% Miniature Ceramic  
 C3 .33uf 10% Miniature Ceramic  
 C4 .33uf 10% Miniature Ceramic  
 C5 .33uf 10% Miniature Ceramic  
 C6 .33uf 10% Miniature Ceramic  
 C7 .33uf 10% Miniature Ceramic  
 C8 .33uf 10% Miniature Ceramic  
 C9 470PF Silver Mica, CM05  
 C10 220PF Silver Mica, CM05  
 C11 1uf 10% Miniature Ceramic

Integrated Circuits

I1 OP-20GP Op Amp  
 I2 CD4066AE Quad Switch  
 I3 UA776TC Op Amp  
 I4 CD4066AE Quad Switch  
 I5 OP-20GP Op Amp  
 I6 CD4046AE Phase-locked Loop VCO  
 I7 CD4013BE Dual Flip-Flop

Potentiometers

P1 500K ohm 20 Turn Trimmer  
 P2 2K ohm 20 Turn Trimmer  
 P3 500K ohm 20 Turn Trimmer  
 P4 500K ohm 20 Turn Trimmer  
 P5 2K ohm 20 Turn Trimmer

Diode

CR1 1N914  
 CR2 1N914

Transformer

T1 IDOT-118 (TRW)

Printed Circuit Board

1 C30017-NBIS

Resistors

R1 3.9K ohm 1/4W Carbon 5%  
 R2 39K ohm 1/4W Carbon 5%  
 R3 56K ohm 1/4W Carbon 5%  
 R4 100K ohm 1/4W Carbon 5%  
 R5 56K ohm 1/4W Carbon 5%  
 R6 220K ohm 1/4W Carbon 5%  
 R7 220K ohm 1/4W Carbon 5%  
 R8 not used  
 R9 1.69K ohm RN55C Metal Film 1%  
 R10 330K ohm 1/4W Carbon 5%  
 R11 100 ohm 1/4W Carbon 5%  
 R12 470K ohm 1/4W Carbon 5%  
 R13 470K ohm 1/4W Carbon 5%  
 R14 2.2M ohm 1/4W Carbon 5%  
 R15 100K ohm 1/4W Carbon 5%  
 R16 3.9K ohm 1/4W Carbon 5%  
 R17 39K ohm 1/4W Carbon 5%  
 R18 56K ohm 1/4W Carbon 5%  
 R19 100K ohm 1/4W Carbon 5%  
 R20 56K ohm 1/4W Carbon 5%  
 R21 220K ohm 1/4W Carbon 5%  
 R22 220K ohm 1/4W Carbon 5%  
 R23 not used  
 R24 1.69K ohm RN55C Metal Film 1%  
 R25 330K ohm 1/4W Carbon 5%  
 R26 100 ohm 1/4W Carbon 5%  
 R27 5.6M ohm 1/4W Carbon 5%  
 R28 1.5M ohm 1/4W Carbon 5%  
 R29 390K ohm 1/4W Carbon 5%  
 R30 470 ohm 1/4W Carbon 5%

Transistors

Q1 2N5089  
 Q2 2N4402  
 Q3 2N5089  
 Q4 2N4402  
 Q5 2N4126

Connector

1 7022-035-000-001 Elco

SIGNAL PROCESSOR CARD

CIRCUIT BOARD ASSEMBLY #C10781-G2, REV B

Capacitors

C1 .1uf Metallized Polycarbonate  
 C2 .1uf Metallized Polycarbonate  
 C3 .1uf Metallized Polycarbonate  
 C4 .1uf Metallized Polycarbonate  
 C5 .1uf Metallized Polycarbonate  
 C6 .1uf Metallized Polycarbonate  
 C7 .1uf Metallized Polycarbonate  
 C8 .1uf Metallized Polycarbonate  
 C9 .047uf Metallized Polycarbonate  
 C10 .047uf Metallized Polycarbonate  
 C11 .001uf Polyester Film  
 C12 .022uf Polyester Film  
 C13 1uf 10% Miniature Ceramic

Integrated Circuits

I1 CD4066AE Quad Switch  
 I2 CD4066AE Quad Switch  
 I3 CD4013AE Dual Flip-Flop  
 I4 UA776TC Op Amp  
 I5 UA776TC Op Amp  
 I6 UA776TC Op Amp  
 I7 UA776TC Op Amp  
 I8 UA776TC Op Amp  
 I9 CA3078S Amplifier  
 I10 CD4066AE Quad Switch  
 I11 CD4013AE Dual Flip-Flop  
 I12 CD4046AE Phase-locked Loop VCO

Edge Connector

1 7022-035-000-001 Elco

Potentiometers

P1 not used  
 P2 1M ohm 20 Turn Trimmer  
 P3 20K ohm 20 Turn Trimmer  
 P4 20K ohm 20 Turn Trimmer

Terminal

1 140-1785-02-01-00 Cambion

Resistors

\*R1 200K ohm RN55C Metal Film 1%  
 \*R2 200K ohm RN55C Metal Film 1%  
 R3 1K ohm RN55C Metal Film 1%  
 R4 2.21K ohm RN55C Metal Film 1%  
 R5 249K ohm RN55C Metal Film 1%  
 R6 1M ohm RN55C Metal Film 1%  
 R7 2.7M ohm 1/4W Carbon 5%  
 R8 22.1K ohm RN55C Metal Film 1%  
 R9 2.49K ohm RN55C Metal Film 1%  
 R10 2.7M ohm 1/4W Carbon 5%  
 R11 1M ohm RN55C Metal Film 1%  
 R12 301K ohm RN55C Metal Film 1%  
 R13 301K ohm RN55C Metal Film 1%  
 R14 150K ohm 1/4W Carbon 5%  
 R15 not used  
 R16 jumper  
 R17 not used  
 \*R18 100K ohm RN55C Metal Film 1%  
 \*R19 100K ohm RN55C Metal Film 1%  
 R20 1K ohm RN55C Metal Film 1%  
 R21 2.21K ohm RN55C Metal Film 1%  
 R22 1M ohm RN55C Metal Film 1%  
 R23 2.7M ohm 1/4W Carbon 5%  
 R24 200K ohm RN55C Metal Film 1%  
 R25 27.4K ohm RN55C Metal Film 1%  
 R26 2.49K ohm RN55C Metal Film 1%  
 R27 2.7M ohm 1/4W Carbon 5%  
 R28 1M ohm RN55C Metal Film 1%  
 R29 39.2K ohm RN55C Metal Film 1%  
 R30 121K ohm RN55C Metal Film 1%  
 R31 2.7K ohm 1/4W Carbon 5%  
 R32 10K ohm 1/4W Carbon 5%  
 R33 1M ohm 1/4W Carbon 5%  
 R34 5.6M ohm 1/4W Carbon 5%  
 R35 680K ohm 1/4W Carbon 5%  
 R36 1.5M ohm 1/4W Carbon 5%  
 R37 220K ohm 1/4W Carbon 5%  
 R38 150K ohm 1/4W Carbon 5%

Printed Circuit Board

1 C30030 Rev B NBIS

\*Selected for 0.1% Match

ANALOG-TO-DIGITAL CONVERTER CARD

CIRCUIT BOARD ASSEMBLY #C10273-G2, REV F

Capacitors

C1 1uf Metallized Polycarbonate  
C2 100PF Silver Mica, CM05  
C3 not used  
C4 .47uf 10% Miniature Ceramic

Integrated Circuits

I1 OP-20GP Op Amp  
I2 CD4066AE Quad Switch  
I3 CD4013AE Dual Flip-Flop  
I4 CD4030AE Quad Exclusive-OR  
I5 CD4001AE Quad NOR  
I6 CD4013AE Dual Flip-Flop  
I7 CD4013AE Dual Flip-Flop  
I8 Jumper Top Side  
I9 Jumper Top Side  
I10 CD4013AE Dual Flip-Flop  
I11 CD4029AE Up/Down Counter  
I12 MC14585 4-Bit Comparator

Transistors

Q1 2N4124  
Q2 2N4126  
Q3 2N4126  
Q4 2N4124

Potentiometers

P1 500K ohm 20 Turn Trimmer  
P2 10K ohm 20 Turn Trimmer

Edge Connector

1 7022-035-000-001 Elco

Terminal

1 140-1785-02-01-0 Cambion

Resistors

R1 45.3K ohm RN55C Metal Film 1%  
R2 499 ohm RN55C Metal Film 1%  
R3 150K ohm RN55C Metal Film 1%  
R4 301K ohm RN55C Metal Film 1%  
R5 not used  
R6 270K ohm 1/4W Carbon 5%  
R7 22K ohm 1/4W Carbon 5%  
R8 560K ohm 1/4W Carbon 5%  
R9 270K ohm 1/4W Carbon 5%  
R10 270K ohm 1/4W Carbon 5%  
R11 560K ohm 1/4W Carbon 5%  
R12 100K ohm 1/4W Carbon 5%  
R13 100K ohm 1/4W Carbon 5%  
R14 1.0M ohm RN55C Metal Film 1%  
R15 22K ohm 1/4W Carbon 5%

**POWER AND TIMING CARD**  
**CIRCUIT BOARD ASSEMBLY #C10263-G2, REV F**

Capacitors

C1 0.1uf 10% Miniature Ceramic  
 C2 100uf, 10V Tantalum, 150D  
 C3 100uf, 10V Tantalum, 150D  
 C4 200PF Silver Mica, CM05  
 C5 200PF Silver Mica, CM05  
 C6 47PF Silver Mica, CM05  
 C7 30PF Silver Mica, CM05  
 C8 1.9-15.7PF Trimmer

Integrated Circuits

I1 UA776TC Op Amp  
 I2 UA776TC Op Amp  
 I3 CD4017AE Decade Counter  
 I4 CD4013AE Dual Flip-Flop  
 I5 CD4011AE Quad 2-input NAND  
 I6 CD4011AE Quad 2-input NAND  
 I7 CD4017AE Decade Counter  
 I8 CD4013AE Dual Flip-Flop  
 I9 MC14572 Hex Gate  
 I10 CD4024AE 7-Stage Binary Counter  
 I11 MC14566 Time Base Generator

Switch

S1 MTM 106D-RA Alco

Connector

1 7022-035-000-001 Elco

Fuse

F1 3AG 1/2 A.P.T. Little Fuse

Crystal

K1 32768 Hz Reeves Hoffman

Potentiometers

P1 20K ohm 20 Turn Trimmer  
 P2 20K ohm 20 Turn Trimmer

Resistor

R1 560K ohm 1/4 W Carbon  
 R2 68K ohm 1/4 W Carbon  
 R3 470K ohm 1/4 W Carbon  
 R4 100K ohm RN55C Metal Film 1%  
 R5 200K ohm RN55C Metal Film 1%  
 R6 1.0M ohm 1/4 W Carbon  
 R7 10K ohm 1/4 W Carbon  
 R8 3.3K ohm 1/4 W Carbon  
 R9 100K ohm RN55C Metal Film 1%  
 R10 200K ohm RN55C Metal Film 1%  
 R11 499K ohm RN55C Metal Film 1%  
 R12 499K ohm RN55C Metal Film 1%  
 R13 470K ohm 1/4W Carbon  
 R14 2.7 ohm 1/4W Carbon  
 R15 2.7 ohm 1/4W Carbon  
 R16 22K ohm 1/4W Carbon  
 R17 22K ohm 1/4W Carbon  
 R18 22K ohm 1/4W Carbon  
 R19 150K ohm 1/4W Carbon  
 R20 22M ohm 1/4W Carbon

Diodes

CR1 1N914  
 D1 LVA 459A Zener 6.0V

Transistors

Q1 AD821  
 Q2 2N4402

Printed Circuit Board

1 C30025 REV B NBIS

ACCUMULATOR CARD

CIRCUIT BOARD ASSEMBLY #C10785-G2, REV A

Capacitors

C1 470PF Silver Mica, CM05  
C2 470PF Silver Mica, CM05  
C3 220PF Silver Mica, CM05  
C4 220PF Silver Mica, CM05  
C5 .1uf 10% Miniature Ceramic  
C6 330PF Silver Mica, CM05

Resistors

R1 22K ohm 1/4W Carbon 5%  
R2 22K ohm 1/4W Carbon 5%  
R3 100K ohm 1/4W Carbon 5%  
R4 330K ohm 1/4W Carbon 5%  
R5 680 ohm 1/4W Carbon 5%  
R6 33K ohm 1/4W Carbon 5%

Integrated Circuits

I1 MC14562 128-Bit Shift Register  
I2 MC14562 128-Bit Shift Register  
I3 CD4029AE Up/Down Counter  
I4 CD4029AE Up/Down Counter  
I5 CD4021AE 8-Stage Shift Register  
I6 CD4029AE Up/Down Counter  
I7 CD4029AE Up/Down Counter  
I8 CD4021AE 8-Stage Shift Register  
I9 CD4029AE Up/Down Counter  
I10 CD4029AE Up/Down Counter  
I11 CD4021AE 8-Stage Shift Register  
I12 CD40103AE Down Counter  
I13 CD4011AE Quad 2-Input NAND  
I14 CD4001AE Quad NOR  
I15 CD4017AE Decade Counter  
I16 CD40103AE Down Counter

Connector

1 7022-035-000-001 Elco

Printed Circuit Board

1 C30091 Rev A NBIS

TIME AND TEMPERATURE CARD

CIRCUIT BOARD ASSEMBLY #C10840-G1, REV A

Capacitors

C1 100PF Silver Mica, CM05  
 C2 220PF Silver Mica, CM05  
 C3 .001uf 10% Miniature Ceramic  
 C4 .33uf 10% Miniature Ceramic  
 C5 .1uf 10% Miniature Ceramic  
 C6 .33uf 10% Miniature Ceramic  
 C7 .1uf 10% Miniature Ceramic  
 C8 220PF Silver Mica, CM05  
 C9 100PF Silver Mica, CM05  
 C10 100PF Silver Mica, CM05  
 C11 .47uf Metallized Polycarbonate  
 C12 .1uf 10% Miniature Ceramic

Integrated Circuits

I1 CD4040AE Binary Counter/Divider  
 I2 CD4013AE Dual Flip-Flop  
 I3 UA776TC Op Amp  
 I4 CD4013AE Dual Flip-Flop  
 I5 CD4013AE Dual Flip-Flop  
 I6 CD4021AE 8-Stage Shift Register  
 I7 CD4040AE Binary Counter/Divider  
 I8 MC14572 Hex Gate  
 I9 CD4021AE 8-Stage Shift Register  
 I10 CD4040AE Binary Counter/Divider  
 I11 CD4021AE 8-Stage Shift Register  
 I12 CD4040AE Binary Counter/Divider  
 I13 CD4021AE 8-Stage Shift Register  
 I14 CD4040AE Binary Counter/Divider  
 I15 CD4021AE 8-Stage Shift Register  
 I16 CD4021AE 8-Stage Shift Register

Connector

1 7022-035-000-001 Elco

Printed Circuit Board

1 C30097 - NBIS

Resistors

R1 100K ohm 1/4W Carbon 5%  
 R2 10K ohm 1/4W Carbon 5%  
 R3 47K ohm 1/4W Carbon 5%  
 R4 47K ohm 1/4W Carbon 5%  
 R5 10K ohm 1/4W Carbon 5%  
 R6 100K ohm 1/4W Carbon 5%  
 R7 100K ohm 1/4W Carbon 5%  
 R8 100K ohm 1/4W Carbon 5%  
 R9 100K ohm 1/4W Carbon 5%  
 R10 560K ohm 1/4W Carbon 5%  
 R11 560K ohm 1/4W Carbon 5%  
 R12 100K ohm 1/4W Carbon 5%  
 R13 100K ohm 1/4W Carbon 5%  
 R14 100K ohm 1/4W Carbon 5%  
 R15 22K ohm 1/4W Carbon 5%  
 R16 150K ohm RN55C Metal Film 1%  
 R17 TBD RN55C Metal Film 1%  
 R18 182K ohm RN55C Metal Film 1%  
 R19 TBD RN55C Metal Film 1%  
 R20 12K ohm RN55C Metal Film .1%  
 R21 5.6M ohm 1/4W carbon 5%  
 R22 34.8K ohm RN55C Metal Film 1%  
 R23 6.81K ohm RN55C Metal Film 1%  
 R24 22 ohm 1/4W Carbon 5%

Transistors

Q1 2N5089  
 Q2 2N5089  
 Q3 2N5640

Diodes

CR1 1N914  
 CR2 1N914

MEMODYNE FORMATTER (TYPE II) CARD

CIRCUIT BOARD ASSEMBLY #C10778-G2, REV B

Capacitors

C1 1uf 10%, Miniature Ceramic  
C2 .082uf 10%, Miniature Ceramic  
C3 .01uf 10%, Miniature Ceramic  
C4 .1uf 10%, Miniature Ceramic

Integrated Circuit

I1 UD5 - 12D50 DC/DC Converter  
I2 CD4024AE 7 Stage Binary Counter  
I3 CD4001AE Quad NOR  
I4 CD4011AE Quad 2-input NAND  
I5 CD401038E Down Counter  
I6 CD4013AE Dual Flip-Flop  
I7 CD4024AE 7 Stage Binary Counter  
I8 CD4013AE Dual Flip-Flop  
I9 CD4013AE Dual Flip-Flop  
I10 CD4050AE Hex Buffer

Printed Circuit Board

1 C30088 Rev A NBIS

Resistors

R1 27K ohm 1/4W Carbon 5%  
R2 2.7 ohm 1/4W Carbon 5%  
R3 220K ohm 1/4W Carbon 5%  
R4 47K ohm 1/4W Carbon 5%  
R5 1K ohm 1/4W Carbon 5%  
R6 4.7M ohm 1/4W Carbon 5%

Transistor

Q1 2N5193  
Q2 2N5089

Potentiometer

P1 5K 20 Turn Trimmer  
P2 20K 20 Turn Trimmer

Connector

1 7022-035-000-001 Elco

## WIRE LIST

The following pages list the wire connections made to each card. Each termination is given a four digit number; the first two digits designate the board number, the second two digits designate the pin number. For example, 0412 is a connection to pin 12 of card 4.

SHIPPING INSTRUCTIONS

The ACM-1 uses lithium batteries. Because of this fact the ACM-1 is classified as a restricted article and special shipping precautions (and paperwork) have to be used. A "Shipper's Certification For Restricted Articles" form must be filled out in at least duplicate. An example for shipping one ACM-1 follows.

Note the following points:

1. Only cargo aircraft to be used.
2. Article number 1032; shipping name "Lithium Metal in cartridges"; class is flammable solid; packaging note number 430.
3. One ACM-1 contains one 5.91b cartridge of Lithium Metal.

The following labels must be on the outside of the shipping containers.

1. "Lithium Metal in cartridges DOT-E-7052"
2. "Dangerous when wet"
3. "Flammable Solid"
4. "Danger- Do not load in passenger aircraft"

Examples of these labels are included on the following pages

Number of Packages	Article Number (See Section IV RAR)	Proper Shipping Name of Article as shown in Section IV of IATA Restricted Articles Regulations (RAR). Specify each article separately.	Class	IATA Packaging Note no. applied	Net Quantity Per Package	Flashpoint (Closed-cup) for Flammable Liquids	
						°C.	°F.
1	1032	Lithium Metal in cartridges	Flammable Solid	43C	5.9 lb	N/A	N/A

Special Handling Information:

I hereby certify that the contents of this consignment are fully and accurately described above by Proper Shipping Name and are classified, packed, marked, labelled and in proper condition for carriage by air according to the current Edition of the IATA Restricted Articles Regulations and all carrier and governmental regulations. I acknowledge that I may be liable for damages resulting from any mistatement or omission and I further agree that any air carrier involved in the shipment of this consignment may rely upon this Certification.

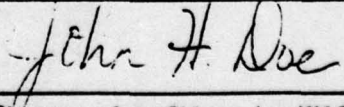
Name and full address of shipper John H. Doe, Inc.		Name and title of person signing Certification John H. Doe	
Sandy Lane		President	
Anywhere, U.S.A.			
Date January 1, 1979		Signature of the Shipper (see WARNING above)	
Air Waybill No.*		Airport of Destination*	Airport of Departure*





LITHIUM METAL IN CARTRIDGES  
DOT-E-7052

**EFFECTS OF SOUND VELOCITY ON THE  
MEASURED CURRENT VELOCITY**

The conversion of digital recorded data on cassette tape to current velocity for the ACM-1 current meter is given by equation (1).

$$U_c = ((N-2048)/2048) (C^2K/4df) \quad (1)$$

where  $U_c$  = calculated velocity component in cm/sec

$N$  = velocity data

$C$  = speed of sound in water in cm/sec

$K$  = calibration factor (normally 1.000)

$d$  = transducer spacing (11.4 cm)

$f$  = acoustic frequency (1605000 Hz)

As long as the speed of sound is known and is used in the conversion process, all effects of sound velocity are eliminated. What are the effects on the calculated velocity if the speed of sound is known to some error?

The speed of sound can be given by equation (2).

$$C/100 = 1449 + 4.6T - .055 T^2 + .0003T^3 + \\ (1.39 - .012T) (S - 35) + .017D \quad (2)$$

where  $T$  = water temperature in degrees celcius

$S$  = salinity in parts per thousand

$D$  = depth below surface in meters

the partial derivatives with respect to  $T$ ,  $S$  and  $D$  are given by equations (3), (4) and (5).

$$dC/dT = 100 (4.6 - .11T + .0009T^2 - \\ .012 (S - 35)) \quad (3)$$

$$dC/dS = 100 (1.39 - .012T) \quad (4)$$

$$dC/dD = 100 (.017) \quad (5)$$

Let  $U_n$  = calculated velocity component based on a nominal sound velocity

$C_{nom}$  = nominal sound velocity for temperature of  $15^{\circ}\text{C}$ , salinity of 35 ppt and depth of zero

An equation for  $U_n$  can be written.

$$U_n = ((N - 2048)/2048) (C_{nom}^2 K/4df) \quad (6)$$

Eliminating  $N$ ,  $K$ ,  $d$  and  $f$  between equations (1) and (6) produces equation (7).

$$U_n = U_c C_{nom}^2 / C^2 \quad (7)$$

For an actual current of 100 cm/sec,  $U_c$  will equal 100 cm/sec to the accuracy of instrument.

$$U_c = 100 \text{ cm/sec} \quad (8)$$

The partial derivatives of  $U_n$  with respect to  $T$ ,  $S$  and  $D$  are given below.

$$dU_n/dT = (-2U_c C_{nom}^2 / C^3) (dC/dT) \quad (9)$$

$$dU_n/dS = (-2U_c C_{nom}^2 / C^3) (dC/dS) \quad (10)$$

$$dU_n/dD = (-2U_c C_{nom}^2 / C^2) (dC/dD) \quad (11)$$

Tabulated results of  $C$ ,  $U_n$ ,  $dU_n/dT$ ,  $dU_n/dS$  and  $dU_n/dD$  for various  $T$ ,  $S$  and  $D$  are given in tables A-1, A-2 and A-3. Note that  $T$ ,  $S$  and  $D$  are varied one variable at a time around  $T = 15^{\circ}\text{C}$ ,  $S = 35$  ppt and  $D = 0$ . The actual current velocity is 100 cm/sec.

The following points can be made from the data of Tables A-1, A-2 and A-3.

1. Temperature should be known to  $\pm 1^{\circ}\text{C}$  for conversion accuracies better than 1%.
2. Salinity should be known to  $\pm 6$  ppt for conversion accuracies better than 1%.

3. Depth should be known to  $\pm 500$  meters for conversion accuracies better than 1%.

In the normal ACM-1, temperature is measured every 10 averages to an accuracy of  $\pm 0.5^{\circ}\text{C}$ . The depth is known from the deployment and for most situations the average salinity is known to the at least  $\pm 6$  ppt. The conclusion can be made that for most applications the effects of sound velocity can be eliminated to better than 1%.

TABLE A-1: TEMPERATURE EFFECTS ON SOUND VELOCITY AND NOMINAL  
CURRENT VELOCITY FOR S=35PPT AND D=0

T DEG C	C CM/SEC	Un CM/SEC	dUn/dT CM/SEC/DEG
-2	143958	109.53	-.73
-1	144434	108.81	-.71
0	144900	108.11	-.69
1	145355	107.44	-.66
2	145798	106.79	-.64
3	146231	106.15	-.62
4	146654	105.54	-.60
5	147066	104.95	-.58
6	147468	104.38	-.56
7	147861	103.83	-.54
8	148243	103.29	-.53
9	148616	102.77	-.51
10	148980	102.27	-.49
11	149334	101.79	-.48
12	149680	101.32	-.46
13	150016	100.87	-.45
14	150344	100.43	-.43
15	150664	100.00	-.42
16	150975	99.59	-.41
17	151278	99.19	-.39
18	151573	98.80	-.38
19	151860	98.43	-.37
20	152140	98.07	-.36
21	152412	97.72	-.34
22	152677	97.38	-.33
23	152936	97.05	-.32
24	153187	96.73	-.31
25	153431	96.43	-.30
26	153669	96.13	-.29
27	153901	95.84	-.28
28	154127	95.56	-.28
29	154346	95.29	-.27
30	154560	95.02	-.26
31	154768	94.77	-.25
32	154971	94.52	-.24
33	155169	94.28	-.24
34	155361	94.04	-.23
35	155549	93.82	-.22
36	155732	93.60	-.22
37	155910	93.38	-.21
38	156084	93.18	-.21
39	156254	92.97	-.20

TABLE A-2: DEPTH EFFECTS ON SOUND VELOCITY AND NOMINAL  
CURRENT VELOCITY FOR T=15 DEG C AND S=35PPT

D METERS	C CM/SEC	Un CM/SEC	dUn/dD CM/SEC/DEG
0	150664	100.00	-.0023
200	151004	99.55	-.0022
400	151344	99.10	-.0022
600	151684	98.66	-.0022
800	152024	98.22	-.0022
1000	152364	97.78	-.0022
1200	152704	97.35	-.0022
1400	153044	96.91	-.0022
1600	153384	96.49	-.0021
1800	153724	96.06	-.0021
2000	154064	95.64	-.0021
2200	154404	95.21	-.0021
2400	154744	94.80	-.0021
2600	155084	94.38	-.0021
2800	155424	93.97	-.0021
3000	155764	93.56	-.0020
3200	156104	93.15	-.0020
3400	156444	92.75	-.0020
3600	156784	92.35	-.0020
3800	157124	91.95	-.0020
4000	157464	91.55	-.0020
4200	157804	91.16	-.0020
4400	158144	90.76	-.0020
4600	158484	90.38	-.0019
4800	158824	89.99	-.0019
5000	159164	89.60	-.0019
5200	159504	89.22	-.0019
5400	159844	88.84	-.0019
5600	160184	88.47	-.0019
5800	160524	88.09	-.0019
6000	160864	87.72	-.0019

TABLE A-3: SALINITY EFFECTS ON SOUND VELOCITY AND NOMINAL  
CURRENT VELOCITY FOR T=15 DEG C AND D=0

S PPT	C CM/SEC	Un CM/SEC	dUn/dD CM/SEC/DEG
0	146429	105.87	-.17
1	146550	105.69	-.17
2	146671	105.52	-.17
3	146792	105.35	-.17
4	146913	105.17	-.17
5	147034	105.00	-.17
6	147155	104.83	-.17
7	147276	104.65	-.17
8	147397	104.48	-.17
9	147518	104.31	-.17
10	147639	104.14	-.17
11	147760	103.97	-.17
12	147881	103.80	-.17
13	148002	103.63	-.17
14	148123	103.46	-.17
15	148244	103.29	-.17
16	148365	103.12	-.17
17	148486	102.96	-.17
18	148607	102.79	-.17
19	148728	102.62	-.17
20	148849	102.45	-.17
21	148970	102.29	-.17
22	149091	102.12	-.17
23	149212	101.96	-.17
24	149333	101.79	-.16
25	149454	101.63	-.16
26	149575	101.46	-.16
27	149696	101.30	-.16
28	149817	101.13	-.16
29	149938	100.97	-.16
30	150059	100.81	-.16
31	150180	100.65	-.16
32	150301	100.48	-.16
33	150422	100.32	-.16
34	150543	100.16	-.16
35	150664	100.00	-.16
36	150785	99.84	-.16
37	150906	99.68	-.16
38	151027	99.52	-.16
39	151148	99.36	-.16
40	151269	99.20	-.16
41	151390	99.04	-.16
42	151511	98.89	-.16
43	151632	98.73	-.16
44	151753	98.57	-.16
45	151874	98.41	-.16
46	151995	98.26	-.16
47	152116	98.10	-.16
48	152237	97.94	-.16
49	152358	97.79	-.16
50	152479	97.63	-.15

## ACOUSTIC VECTOR AVERAGING CURRENT METER

### General Purpose

This instrument uses a combination of two axis acoustic velocity sensing and two axis magnetic sensing along with internal signal processing, magnetic tape recorder and batteries to record for periods up to 1 year, the continuously averaged N/S and E/W components of current flow in fluids such as water for sampling intervals that can be internally set for values from 1 minute to 15 minutes.

The first commercial embodiment of the concept is designed for use in a oceanographic mooring at depths down to 6,000 meters.

The salient features of this design are (1) the complete absence of moving parts exposed to the marine environment, (2) extremely high sensitivity, (3) excellent cosine response, (4) very low power consumption (5) excellent zero stability (6) high linearity.

### Historical Background

The majority of current measurements from moored instruments in the past have been performed using current meters equipped with Savonius rotors and vane followers. Internally they have used magnetic compass cards fitted with an optically encoded disc to read direction. These current meters present problems that have, to some extent, been recognized by users for many years. These problems are as follows:

- i) poor reliability caused by direct exposure of mechanical moving parts to the marine environment;
- ii) unsuitable hydrodynamic properties of the Savonius rotor and vane follower leading to poor data quality particularly on moorings with surface floats.

Various attempts have been made in the past to design better instruments. These designs have utilized acoustic, electromagnetic and various other sensing techniques. There are probably many reasons why none of these designs has seen extensive use. Some of the reasons are as follows:

- i) The design was incomplete, e.g., no provision for digital recording, no vector averaging, no direction sensor;
- ii) problems of zero drift (E.M. type);

- iii) power consumption too high;
- iv) did not work in clear ocean water (acoustic backscatter type);
- v) very limited data storage.

For these and numerous other reasons the Savonius rotor and vane follower approach with various methods of internal data processing and storage, has persisted even through their deficiencies have been recognized for many years. An examination of the characteristics of current meters in general leads to the conclusion that the mechanical types are generally quite unsuitable. The Savonius rotor's unequal acceleration and deceleration rates and non cosine response make it particularly unsuitable. The electromagnetic current meters have the disadvantage that their electrical output is proportional to magnetic field. This field decreases rapidly with distance from the coil. Consequently, they are sensitive only to fluid flow in the immediate vicinity of the coil which, due to its bulk, severely affects the flow being measured. The acoustic backscatter type while appearing to have theoretically ideal characteristics has not been generally successful due to the poor distribution of suitable scatterers in clear ocean water.

Thus it was felt that current meters in which current is sensed by measuring the differential travel time of acoustic signals travelling with and against the fluid flow offered better possibilities. The reasons are (1) response is inherently linear and extremely fast (2) sensitivity is uniform over the acoustic path (3) the transducers are small (4) signal to noise ratio is excellent (5) it can be made to have close to ideal cosine response (6) calibration can be accurately inferred from frequency, sound velocity and transducer spacing.

Numerous acoustic current meters using this basic concept have been described in the literature. The concept has been implemented in a number of different ways some of which are (1) short pulse using 2 transmitters and 2 receivers for each axis (2) short pulse using 2 transducers each acting as both a transmitter and receiver (3) dual "sing-around" sound velocimeters with straight line sound paths in opposite directions (the difference in the "sing-around" frequency being a linear function of current.) (4) continuous wave using two widely different high frequency carriers (e.g. 1.1 and 1.6MHz, but modulated with an identical signal of lower frequency (e.g. 20kHz where the phase difference of the modulating signal on the received carriers is a linear function of current velocity.<sup>8</sup>) (5) continuous wave bursts using a single frequency (e.g. 2MHz) on a single pair of transducers, the burst interval being approximately equal the acoustic travel time between the two transducers.<sup>8</sup> The received bursts resynchronize "slave" oscillators which maintain phase information between bursts. The continuous output of the "slave"

oscillators in heterodyned with a local oscillator resulting in outputs of 8kHz. Phase difference between the 8kHz signals is a linear function of current.

The first three methods require the measurement of arrival time differences of pulses with sufficient speed to resolve currents less than 1cm/sec. It can be shown that

$$\Delta T = \frac{2vd}{c^2}$$

where  $\Delta T$  = arrival time difference  
 $v$  = current velocity  
 $d$  = transducer spacing  
 $c$  = velocity of sound

For  $d = 11\text{cm}$ ,  $c = 1500\text{m/s}$ , the time difference is  $1 \times 10^{-9}$ . Time resolution as short as this requires extremely high speed circuitry and auto calibration features such as those described by Gytre. The first method using separate transducers for receiving and transmitting suffers from the additional disadvantage of requiring extremely stable relative position between the receiver and transmitter of each pair. For example, a change in relative position between the receiver and transmitter of each pair of  $10^{-6}\text{m}$  for an acoustic path length of 10cm causes a change in arrival time equivalent to a current change of 0.8cm/s. The fourth method while free of problems associated with threshold detection of pulses, etc. does require the measurement of phase difference to the same time resolution as types 1, 2 and 3 above. The fifth method has the advantage that the phase angle measured at the relatively low beat frequency is the same phase angle difference that occurs at the carrier frequency. This permits a time measurement that can be slower by the ratio of the carrier to the beat frequency for a given current speed.

In 1974 NBIS submitted an unsolicited proposal to the Office of Naval Research (U.S. Navy) for the development of an acoustic current meter (ACM) utilizing a continuous wave concept. This meter was intended for deep ocean moored applications. Later in 1974 NBIS submitted a proposal to Johns Hopkins University Applied Physics Laboratory for the development of a specialized 3 axis version of the instrument. The JHU/APL design was intended for the measurement of rapid (100 sample/seconds) small scale variations (turbulence) while mounted on the bow of a submarine. Both proposals were funded and work commenced early in 1975. Due to the inflexible cruise schedules of Navy submarines, the JHU/APL contract was given a higher priority and hardware was delivered to JHU/APL early in 1976. It was subsequently successfully tested and extensively used at sea. The enclosed reprint (ISA - 1976) describes

the approach used and the results. During the development of this hardware it was realized that a "continuous wave burst" technique similar in some ways to that described by Lester (see bibliography in enclosed reprint) offered some very attractive practical advantages. Consequently when work on the moored current meter (U.S. Navy contract) was commenced in earnest this concept described below was put into effect. The first experimental prototype of this concept was extensively tested at the National Ship Research & Development Center by personnel of the National Oceanographic Instrumentation Center on behalf of the National Data Buoy Office (Dept. of Commerce). NDBO contributed additional funding to this project by transferring funds to the U. S. Navy. Later in 1977 three pre-production prototypes which were complete with magnetic compasses and digital magnetic tape recorders were delivered to NDBO under an extension to the original Navy Contract.

Continuous Wave Burst Concept. Fig 4.1-3 illustrates the sensor geometry for one of the two axes of the ACM. The two transducers are aimed directly at an acoustic mirror in such a way that the reflected acoustic signal from each transducer is aimed directly at the other. The transducers are discs approximately 3/8" diam x 0.04" thick made from a commercially available piezoelectric material. Fig. 1.2.5-2 illustrates the 2 axes geometry.

Fig. 4.1.3-1 illustrates the timing of transmitted and received acoustic signals and the resulting outputs of the unfiltered and filtered outputs of the square law detectors.

The operation is as follows. Every 610  $\mu$ s a 91.5  $\mu$ s long burst at 1.605000 MHz is simultaneously applied to each of a pair of transducers resulting in acoustic signals simultaneously starting out in opposite directions. Referring to fig. 4.1-3 the signal going from transducer A to B will arrive at B sooner than the other since it is travelling in the same direction as the indicated current. Consequently the phase of the signal received at transducer B will be advanced relative to that received at transducer A. The total phase shift between each transmitted and received burst is dependent on a large number of variables such as:

- (a) Total acoustic path length
- (b) Velocity of sound in water
- (c) Flow velocity of fluid medium
- (d) The electro-acoustic parameters of the transducers in both receiving and transmitting modes.

However, it will be shown that the method developed by NBIS results in the following simple relationship between phase shift ( $\theta$ ) between the received signals and current velocity ( $v$ ) is given by

$$\theta = \frac{2vd\omega}{c^2}$$

$\omega$  = angular frequency of acoustic signals

$v$  = fluid velocity

$d$  = direct distance between transducers

$c$  = velocity of sound in the fluid medium

Since  $d$  and  $\omega$  are fixed the only undesirable factor is the variation of velocity of sound ( $c$ ) in the medium. However, under normal conditions of use the parameters affecting  $c$  are either well enough known from historical data or can be inferred from the temperature measured by the acoustic current meter temperature channel and the known depth of deployment.

Properties of Continuous Wave Burst Signals. The reason for using a Continuous Wave Burst Signal (CWB) is permit time multiplexing of each transducer between the receive mode and transmit mode. The CWB signal is transmitted from each transducer for a period long enough to result in a continuous wave train equal to about 60% of the total travel time from one transducer to the other. The remaining 40% of the time is to allow the mechanical oscillation in each transducer to decay to a negligible level before the acoustic signal from the other transducer arrives (fig. 4.1.3-1). After the transducer response to the received signal reaches steady state conditions the "receive gate" is opened thus resulting in an input to each of the square law detectors.

A CWB signal is essentially a continuous wave carrier ( $E_{co}$ ) modulated by a signal  $M$  consisting of repetitive rectangular pulses.

The Fourier series for a repetitive rectangular pulse  $M$  is as follows:

$$M = K_1 + \frac{2}{\pi} \sum_{n=1}^{\infty} \left\{ \frac{1}{n} \sin(nK\pi) \cos(n\omega_2 t) \right\}$$

$K_1$  = Pulse width x pulse repetition frequency

= ON/OFF ratio of  $S_1$  and  $S_2$

$n$  = an integer from 1 to infinity

$\omega_2$  =  $2\pi$  x pulse repetition frequency

$t$  = time

The carrier frequency  $E_{co}$  is given by  $E_{co} = E_o \sin(\omega_1 t)$

Therefore the CWB transmitted signal  $E_T$  is given by

$$\begin{aligned}
 E_t &= M.E_{co} \\
 &= E_o \sin(\omega_1 t) \left[ K_1 + \frac{2}{\pi} \sum_{n=1}^{n=\infty} \left\{ \frac{1}{n} \sin(nK_1\pi) \cos(n\omega_2 t) \right\} \right] \\
 &= K_1 E_o \sin(\omega_1 t) + \frac{2}{\pi} E_o \left[ \sin(\omega_1 t) \sum_{n=1}^{n=\infty} \left\{ \frac{1}{n} \sin(nK_1\pi) \cos(n\omega_2 t) \right\} \right]
 \end{aligned}$$

$K$  has a value of 0.03 for the ACM. For all values of  $n$  it can be shown that since  $\omega_1$  is approximately 10,000,000 and  $\omega_2$  is 10,000 the term in parenthesis contains frequency components that are side bands to  $\omega_1$  which are either of totally insignificant amplitude or result in outputs from the square law detectors that are completely outside the band-pass frequencies (100 to 400 rad/sec) of the band-pass filters. Therefore for purposes of assessing phase angles between the outputs of the band-pass filters  $E_5$  and  $E_6$  we can assume that the transmitted signal  $E_T$  is given by

$$E_T = K_1 E_o \sin(\omega_1 t)$$

Since the receive gates are enabled after the received signals from the preamplifiers have achieved steady state the inputs to the square law detectors can for the same reasons be expressed as follows:

$$E_{RC1} = K_2 \sin(\omega_1 t + \theta_1) \text{ ---- (1a)}$$

where  $K_2$  = ON/OFF ratio of  $S_3$  &  $S_4$

where  $E_{RC1}$  = carrier frequency component of  $E_{R1}$

$\theta_1$  = total phase shift between  $E_{RC1}$  and  $E_{co}$

$$\text{Now } \theta_1 = \phi_{T2} + \omega_1 T_1 + \phi_{R1}$$

Where  $\phi_{T2}$  = phase angle between electrical and acoustic signals at transducer B during transmit mode

$T_1$  = acoustic travel time from transducer B to A.

$\phi_{R1}$  = phase angle between acoustic and electrical signals at transducer A during receive mode.

$$\text{Similarly } \theta_2 = \phi_{T1} + \omega_1 T_2 + \phi_{R2}$$

Phase angle  $\theta$  between the carrier frequency components of  $E_{R1}$  and  $E_{R2}$  (i.e.  $E_{RC1}$  &  $E_{RC2}$ ) is given by

$$\theta = \theta_2 - \theta_1$$

$$\therefore = (\theta_{T1} - \theta_{R1}) + \omega_1(T_2 - T_1) + (\phi_{R2} - \phi_{T2})$$

$$\text{Let } \phi = (\phi_{T1} - \phi_{R1}) + (\phi_{R2} - \phi_{T2}) \text{ -----(1)}$$

$$\begin{aligned} \therefore \theta &= \omega_1(T_2 - T_1) + \phi \\ &= \omega_1 \Delta T + \phi \text{----- (2)} \end{aligned}$$

$$\text{Now } T_1 = T_{AM} + T_{MB} \quad (\text{see fig. 1a})$$

$$T_{AM} = \frac{d_1}{C + v_1}$$

$$d_1 = \frac{d}{2 \sin \theta}$$

$$v_1 = \text{component velocity parallel to } v$$

$$= v \sin \theta$$

$$c = \text{velocity of sound in medium}$$

$$\therefore T_{AM} = \frac{d}{2 \sin \theta (c + v \sin \theta)}$$

$$\text{Similarly } T_{MB} = \frac{d}{2 \sin \theta (c + v \sin \theta)}$$

$$\therefore T_1 = \frac{d}{\sin \theta (c + v \sin \theta)}$$

$$\begin{aligned} \text{Similarly } T_2 &= T_{BM} + T_{MA} \\ &= \frac{d}{\sin \theta (C - v \sin \theta)} \end{aligned}$$

$$\therefore T_2 - T_1 = \Delta T = \frac{2 v d \sin^2 \theta}{\sin^2 \theta (C^2 - v^2 \sin^2 \theta)}$$

since  $c \gg v$

$$\begin{aligned} \therefore \Delta T &= \frac{2 v d \sin^2 \theta}{c^2 \sin^2 \theta} \\ &= \frac{2 v d}{c^2} \end{aligned} \quad (3)$$

It is of interest to note that the travel time difference ( $\Delta T$ ) depends on the direct distance  $d$  between the transducers and is independent of the total acoustic travel distance.

Substituting in equation (2)

$$\text{we get } \theta = \frac{2\omega_1 v d}{c^2} + \phi \quad (4)$$

$$\begin{aligned} (\text{from equation (1)}) \quad \phi &= (\phi_{T1} - \phi_{R1}) + (\phi_{R2} - \phi_{T2}) \quad (5) \\ &= \phi_1 - \phi_2 \end{aligned}$$

Where  $\phi_1$  and  $\phi_2$  are the differences in phase angles between the transmit mode and receive mode of each transducer. Ideally  $\phi_1$  and  $\phi_2$  should each be zero or if not zero, should be equal. If  $\phi$  is zero equation (4) shows that  $\theta$  is zero when current flow is zero i. e. that  $\phi$  is a zero offset term. Obviously the exact value of  $\phi$  and its stability with time, temperature and pressure, etc. is a most critical determinant of zero stability in the current meter. The following is a discussion of the factors influencing  $\phi_{T1}$ ,  $\phi_{R1}$ ,  $\phi_{T2}$  and  $\phi_{R2}$  which in turn determine  $\phi_1$ ,  $\phi_2$  and  $\phi$ .

#### Behavior of Piezo-Electric Transducers

The following is a very brief discussion of piezo-electric transducer theory aimed only at an understanding of factors influencing the transmit/receive phase angles. The subject of piezo-electric transducers is covered very thoroughly in texts such as "Sonics" by T. F. Heuter & R. H. Bolt (John Wiley & Sons) and "Fundamentals of Acoustics" by L. E. Kensler & A. R. Frey (John Wiley & Sons).

Piezoelectric materials produce an electric charge  $Q$  (with resulting electric field) when strained. Conversely a mechanical force is produced within the material when it is subjected to an electric field. Consequently a piezoelectric disc transducer in an acoustic pressure field (i.e. acting as a receiver) will have forces produced at its surface that will result in a surface velocity  $\mu$  given by

$$\mu = \frac{P}{Z_m}$$

where  $P$  = pressure

$Z_m$  - complex mechanical impedance

Therefore the displacement of the surface is given by

$$\begin{aligned} y &= \int u \, dt \\ &= \frac{1}{Z_m} \int p \, dt \end{aligned}$$

The strain  $S = \frac{y}{W}$  (W = thickness)

The resulting charge Q is given by

$$\begin{aligned} Q &= S K_1 && (K_1 = \text{constant}) \\ &= \frac{y K_1}{W} \\ &= \frac{K_1}{W Z_m} \int p \, dt \end{aligned}$$

The short circuit current  $I_s$  is given by

$$\begin{aligned} I_s &= \frac{dQ}{dt} \\ &= \frac{K_1 P}{W Z_m} \text{-----(6)} \end{aligned}$$

When an piezoelectric transducer is used as a generator the force (f) acting at the surface of the transducer is given by

$$f = K_2 V$$

$K_2 = \text{constant}$

V = applied voltage

The resulting velocity  $\mu$  of the surface is given by

$$\begin{aligned} \mu &= \frac{f}{Z_m} \\ &= \frac{K_2 V}{Z_m} \end{aligned}$$

$$p = \rho C u \text{ ---- (7)}$$

where  $\rho$  = density of fluid medium

$C$  = velocity of sound in the medium

$$\text{Therefore } p = \frac{\rho C K_2 V}{Z_m} \text{ ---- (8)}$$

The above discussion assumes that the acoustic signals in each case are plane waves normal to the surface of the transducer. In actual operation the acoustic waves are normal to the surface and since the transducers are approximately 10 wave lengths in diameter the transmitted signals are essentially plane wave. In any case any small departure from ideal would be essentially the same at each transducer and consequently would result in negligible net effects.

In equations (6) and (8) the only time variant parameters are  $I$ ,  $p$  and  $V$  and the only frequency dependent parameter is the complex mechanical impedance  $Z_m$  which is same for both transmitting and receiving modes.

$$\text{Now } Z_m = Z_o e^{j\theta}$$

Where  $Z_o$  = mechanical impedance at resonance

$\theta$  = phase angle between force acting on transducer and the velocity

$$\therefore \text{ From (6) } I_s = \frac{K_1 p e^{-j\theta}}{W Z_o}$$

$$\text{From equation (8) } \frac{p = \rho C K_2 V e^{-j\theta}}{Z_o} \text{ ---- (10)}$$

In other words the phase angle between the short circuit current  $I_s$  and the acoustic pressure signal when acting as a receiver is  $-\theta$  and is the same as the phase angle between generated pressure and the applied voltage when acting as a generator.

Referring to equations (4) and (5) we can say that if in the transmitting mode the transducers are driven from exactly the same voltage and if in the receiving mode they are each shunted by a very low value resistor  $R_s$  (i.e.  $R_s \ll \ll$  transducer electrical impedance) then

$$\phi_{T1} = \phi_{R1} \text{ and } \phi_{T2} = \phi_{R2}$$

$$\text{Therefore } \phi_1 = 0$$

$$\text{and } \phi_2 = 0$$

$$\text{and } \theta = \frac{2\omega_1 v d}{C^2} \text{ ---- (11)}$$

In other words if the conditions for the transmit and receive modes postulated above are satisfied there is no offset and  $\theta$  is exactly zero when  $v$  is zero.

However in practice some compromise must be made in the value of  $R_s$ . The circuit shown in 4.1.1-1 is the equivalent circuit of the piezoelectric transducers at frequencies close to their fundamental resonance. i.e. the actual operating frequency.

Therefore if we consider transducer A only we must examine the effect of  $R_3$  and  $R_5$  on the output current phase relative to the short circuit current in the receive mode. In the transmit mode we must consider the effect of  $R_3$  and  $R_5$  on the phase of voltage directly across the transducer to the phase of  $E_{co}$ .

To simplify this discussion we shall assume that the impedance matching transformers have unity turns ratio. This assumption leads to the simplified circuits where  $L$  is the inductance of matching transformer,  $C_o$  is the "static" capacitance of transducer (i.e. the ratio of static charge  $Q$  to static voltage  $V$  i.e.  $C_o = \frac{Q}{V}$ ).  $C_o$ ,  $R$ ,  $L$  and  $C$  are equivalent electrical circuit of the piezoelectric transducer.  $R$ ,  $L$  and  $C$  represent the dynamic properties due to mechanical resonance coupled with the piezoelectric properties.  $R$  represents the total losses which are the combined effects of internal mechanical losses and the radiated or absorbed acoustic energy.

In the transmit mode the phase shift between  $E_T$  and  $E_{co}$  is given by

$$\alpha = \tan^{-1} \left[ \frac{(R^2 + Z^2) (Y) R_g + ZR_g}{(R^2 + Z^2) + R R_g} \right] \quad \text{-----} \quad (12)$$

$$\text{Where } Z = \left( \omega L - \frac{1}{\omega C} \right)$$

$$Y = \left( \frac{1}{\omega L_o} - \omega C_o \right)$$

$$R_g = \text{generator impedance} \quad (\text{see fig 4a})$$

In the receive modes the phase angle between the output current  $I_1$  and the generator voltage  $E_1$  is given by

$$\beta = \tan^{-1} \left[ \frac{R R_s Y - Z}{R + R_s + R_s Z Y} \right] \quad \text{-----} \quad (13)$$

$$\text{i.e. } \tan \beta = \frac{R R_s Y - Z}{R + R_s + R_s Z Y}$$

$$\text{Where } R_s = \text{Source impedance}$$

When  $R_s = 0$

$$I_1 = I_{sc}$$

( $I_{sc}$  = short circuit current)

Then  $\beta = \beta_0$

( $\beta_0$  = phase angle between  $I_{sc}$  &  $E_1$ )

$$\text{Therefore } \tan \beta_0 = \frac{-Z}{R} \quad \text{-----(15)}$$

The difference in phase shift  $\beta'$  is given by

$$\beta' = \beta - \beta_0$$

$$\tan \beta' = \tan(\beta - \beta_0)$$

$$= \frac{\tan \beta - \tan \beta_0}{1 + \tan \beta \tan \beta_0}$$

Substituting we get  $\beta'$  given by

$$\begin{aligned} \beta' &= \tan^{-1} \left[ \frac{\left( \frac{R R_s Y - Z}{R + R_s + R_s Z Y} \right) - \left( \frac{-Z}{R} \right)}{1 + \left( \frac{R R_s Y - Z}{R + R_s + R_s Z Y} \right) \left( \frac{-Z}{R} \right)} \right] \\ &= \tan^{-1} \left[ \frac{(R^2 + Z^2) (Y) R_s + Z R_s}{(R^2 + Z^2) + R R_s} \right] \end{aligned}$$

$\therefore$  If  $R_g = R_s$

Then  $\beta' = \alpha$  (from eq. 12)

The phase angles  $\alpha$  and  $\beta'$  are of course the same as the angles  $\phi_{T1}$  and  $\phi_{R1}$  in equation (5) and  $\alpha - \beta' = \phi_1$ . Therefore if the generator impedance ( $R_g$ ) in the transmit mode is the same as the load impedance ( $R_s$ ) in the receive mode, then the angles  $\phi_1$  and  $\phi_2$  are zero and the offset angle  $\phi$  (see eq. (5)) is also zero. This is true of course irrespective of any of the other parameters. For example if  $C_0$  changes due to temperature or pressure or any other reason the "offset" angle  $\phi$  is always zero.

equivalent to parallel resistance of  $R_3$  and  $R_5$  (i.e.  $S_3$  closed) and  $R_g$  is equal to  $R_3$  (i.e.  $S_3$  open)

From equation (11) we get

$$\theta = \frac{2\omega vd}{c^2}$$

For  $\omega = 10^7$  rad/sec.

$$d = 11 \text{ cm}$$

$$c = 1.5 \times 10^5 \text{ cm/sec.}$$

$$\theta = 0.0098 \text{ v radians}$$

$$= 0.56 \text{ v degrees}$$

or  $v = 1.78 \text{ cm/sec/degree}$

It can be seen that for large variations in transducer parameters the maximum phase shifts correspond to velocity errors of less than 0.3 cms/sec providing  $R_g$  &  $R_s$  are low or equal. However, when  $R_g$  is increased to 10,000 ohms and  $R_s$  is maintained at 22.4 ohms then the phase differences increase dramatically to values corresponding to velocity errors of 16.6 cm/sec for the same variations in transducer parameters.

A future embodiment of this concept would result in  $R_g$  &  $R_s$  being equal thus eliminating the small errors.

#### Heterodyned Received Signals

In the receive mode the signals  $E_{R1}$  &  $E_{R2}$  consist of the acoustically received signals and the local oscillator signal  $E_{Lo}$ . Since the impedances across the matching transformers ( $T_{X1}$  &  $T_{X2}$ ) are very large (typically 2400 ohms) and are designed to be essentially resistive at the operating frequency (1.605000 MHz) it can be assumed for simplicity that the local oscillator signal components of  $E_{R1}$  and  $E_{R2}$  are exactly in phase with  $E_{Lo}$  and are equal to  $E_{Lo}$

Therefore  $E_{R1}$  is given by

$$E_{R1} = E_{Lo} + E_{RC1}$$

Where  $E_{RC1}$  = acoustically received signal at transducer A

$$= K_2 \sin(\omega_1 t + \theta_1) \quad \text{from (1a)}$$

From previous discussion  $\theta_1$  is given by

$$\theta_1 = \phi_{T2} + \omega T_1 + \phi_{R1}$$

Similarly  $E_{R2} = E_{L0} + E_{RC2}$

Where  $E_{RC2}$  = acoustically received signal at transducer B

$$= K_3 \sin (\omega_1 t + \theta_2) \quad (K_3 = \text{constant})$$

Where  $\theta_2 = \phi_{T1} + \omega T_2 + \phi_{R2}$

Now  $E_{L0} = K_4 \sin \omega_2 t \quad (K_4 = \text{constant})$

$$\therefore E_3 = K_5 (E_{R1})^2 \quad (K_5 = \text{constant})$$

$$= K_5 \left[ K_4 \sin (\omega_2 t) + K_2 \sin (\omega_1 t + \theta_1) \right]^2$$

$$= K_5 \left[ K_4^2 \sin^2 (\omega_2 t) + K_2^2 \sin^2 (\omega_1 t + \theta_1) + 2K_2 K_4 \sin (\omega_2 t) \sin (\omega_1 t + \theta_1) \right]$$

The first two terms contain only components of zero frequency and frequencies of  $2\omega_1$  and  $2\omega_2$  and will be totally removed by the band pass filter. Therefore the remaining component of  $E_3$  is given by

$$E_3 = K \sin (\omega_2 t) \sin (\omega_1 t + \theta_1)$$

$$= \frac{K}{2} \left[ \cos (\omega_2 t - \omega_1 t - \theta_1) - \cos (\omega_2 t + \omega_1 t + \theta_1) \right]$$

$$= \frac{K}{2} \left[ \cos (\omega_2 - \omega_1) t - \theta_1 - \cos ((\omega_2 + \omega_1) t + \theta_1) \right]$$

The band-pass filter is designed to be centered on a frequency of

$$(\omega_2 - \omega_1)$$

Therefore the first term of  $E_3$  will be passed by the band-pass filter and the second term will be eliminated.

$$\text{Therefore } E_5 = \frac{K}{2} \cos (\omega t - \theta_1) \text{ ----- (16)}$$

$$\text{Where } \omega = \omega_2 - \omega_1$$

Equation 16 assumes that at a frequency of  $\omega$  the phase shift through the band-pass filter is zero.

Using the same reasoning  $E_6$  is given by

$$E_6 = \frac{K}{2} \cos (\omega t - \theta_2)$$

∴ The phase shift  $\theta$  between  $E_5$  and  $E_6$  as measured by the phasemeter is given by

$$\begin{aligned}\theta &= \theta_2 - \theta_1 \\ &= \omega_1 \Delta T + \phi && \text{-----from equation (2)} \\ &= \frac{2\omega_1 v d}{c^2} && \text{-----from equation (11)}\end{aligned}$$

The signals  $E_5$  and  $E_6$  at the inputs of the phasemeter are at 34.133 Hz (i.e. the difference between the carrier and local oscillator frequencies) but contain the same phase shifts due to current velocity  $v$  as the carrier frequency (acoustic) signals. Since they are approximately 47000 longer in period than the carrier the time discrimination in the phasemeter is given by

$$\begin{aligned}\delta T &= \frac{\theta}{\omega} \\ &= \frac{2\omega_1 v d}{\omega c^2} \\ &= \frac{2f_1 v d}{f c^2} && \text{----- (17)}\end{aligned}$$

for  $v = 1 \text{ cm/sec.}$   
 $d = 11 \text{ cms.}$   
 $f_1 = 1.605000 \text{ MHz}$   
 $f = 34 \text{ Hz}$   
 $c = 1.5 \times 10^5 \text{ cm/sec}$   
 $\delta T = 4.6 \times 10^{-4} \text{ sec/cm/sec}$   
 $= 46 \text{ } \mu\text{S/cm/sec}$

This requirement is very easily met with the use of readily available micropower integrated circuits (both linear and CMOS logic).

In the foregoing discussion no mention was made of the phase shift or time delay in the preamplifiers or square law detectors. Since  $E_{R1}$  consists of both the local oscillator signal and the acoustically received signal it is obvious that since they are almost identical in frequency (i.e. 1.605000 and 1.605034 MHz) there will be essentially no differential phase shift between the two frequencies even though each may be substantially phase shifted. For example the pre-amplifier for each transducer has a single tuned stage. The maximum rate of change of phase with frequency occurs at resonance and is given by

$$\begin{aligned}\frac{d\theta}{df} &= \frac{2Q}{f} \\ \delta\theta &= \frac{2Q\delta f}{f}\end{aligned}$$

$Q$  = Inverse loss factor of tuned circuit

$$= 20$$

$\therefore$  for  $f = 1.605000$  MHz

$$\delta f = 34\text{Hz}$$

$$\delta\theta = 8.5 \times 10^{-4} \text{ radians}$$

From equation 11 we get

$$\theta = \frac{2\omega_1 v d}{c^2}$$

$$\text{or } \delta v = \frac{c^2 \delta\theta}{2\omega_1 d}$$

for  $\delta\theta = 8.5 \times 10^{-4}$  radian

$$c = 1.5 \times 10^5 \text{ cm/sec}$$

$$\omega_1 = 1.605 \text{ MHz}$$

$$d = 11 \text{ cms}$$

$$\delta v = .086 \text{ cms/sec.}$$

In practice this uncertainty would be compensated by an essentially equal effect for the other transducer preamplifier and square law detector resulting in a completely trivial net effect.