

AD-A071 053

ARMY ENGINEER WATERWAYS EXPERIMENT STATION VICKSBURG MS F/G 8/13
EFFECTS OF BACK-PRESSURE SATURATION TECHNIQUES ON RESULTS OF R --ETC(U)
MAY 79 R T DONAGHE, F C TOWNSEND

UNCLASSIFIED

WES-MP-OL-79-12

NL

| OF |
AD
A071053



END
DATE
FILMED
8 -79
DDC

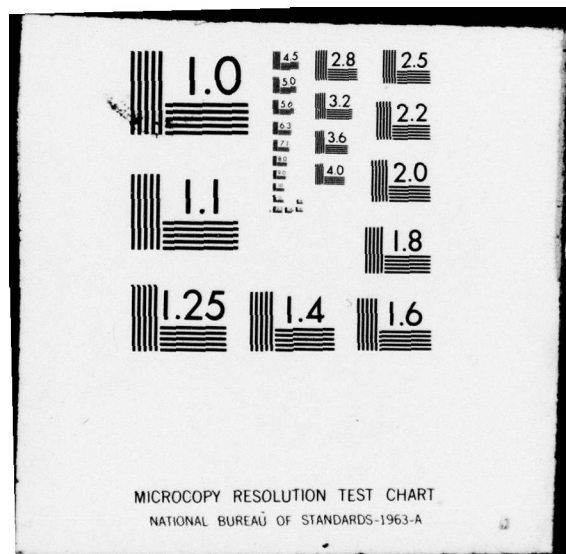

M. P. GL 79-12

EFFECTS OF BACK-PRESSURE SATURATION TECHNIQUES ON RESULTS OF \bar{R} TRIAXIAL COMPRESSION TESTS

MAY 1979

ADA 071053

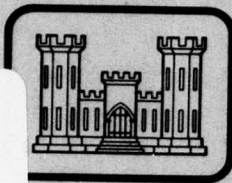

LEVEL # 12



MISCELLANEOUS PAPER GL-79-12

EFFECTS OF BACK-PRESSURE SATURATION TECHNIQUES ON RESULTS OF \bar{R} TRIAXIAL COMPRESSION TESTS

by

Robert T. Donaghe and Frank C. Townsend

Geotechnical Laboratory
U. S. Army Engineer Waterways Experiment Station
P. O. Box 631, Vicksburg, Miss. 39180

May 1979

Final Report

Approved For Public Release; Distribution Unlimited

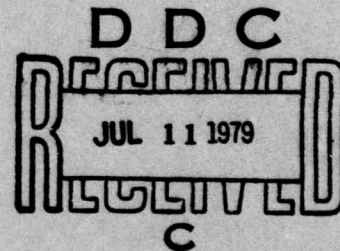

Prepared for Office, Chief of Engineers, U. S. Army
Washington, D. C. 20314

Under CWIS 174

79 07 11 018

**Destroy this report when no longer needed. Do not return
it to the originator.**

**The findings in this report are not to be construed as an official
Department of the Army position unless so designated
by other authorized documents.**

Unclassified

SECURITY CLASSIFICATION OF THIS PAGE (When Data Entered)

REPORT DOCUMENTATION PAGE		READ INSTRUCTIONS BEFORE COMPLETING FORM
1. REPORT NUMBER Miscellaneous Paper GL-79-12	2. GOVT ACCESSION NO.	3. RECIPIENT'S CATALOG NUMBER
4. TITLE (and Subtitle) 6 EFFECTS OF BACK-PRESSURE SATURATION TECHNIQUES ON RESULTS OF R TRIAXIAL COMPRESSION TESTS	5. TYPE OF REPORT & PERIOD COVERED 9 Final report, Jan-Sep 75,	
7. AUTHOR(s) 10 Robert T. Donaghe Frank C. Townsend	8. CONTRACT OR GRANT NUMBER(s) 14 WES-MP-GL-79-12	
9. PERFORMING ORGANIZATION NAME AND ADDRESS U. S. Army Engineer Waterways Experiment Station Geotechnical Laboratory P. O. Box 631, Vicksburg, Miss. 39180	10. PROGRAM ELEMENT, PROJECT, TASK AREA & WORK UNIT NUMBERS CWIS 174	
11. CONTROLLING OFFICE NAME AND ADDRESS Office, Chief of Engineers, U. S. Army Washington, D. C. 20314	12. REPORT DATE 11 May 1979	13. NUMBER OF PAGES 58
14. MONITORING AGENCY NAME & ADDRESS (if different from Controlling Office) 12 63p.	15. SECURITY CLASS. (of this report) Unclassified	
15a. DECLASSIFICATION/DOWNGRADING SCHEDULE		
16. DISTRIBUTION STATEMENT (of this Report) Approved for public release; distribution unlimited.		
17. DISTRIBUTION STATEMENT (of the abstract entered in Block 20, if different from Report)		
18. SUPPLEMENTARY NOTES This investigation was conducted as a part of a study to evaluate laboratory testing procedures for the Office, Chief of Engineers (OCE), under CWIS 174 of the Engineering Studies Program.		
19. KEY WORDS (Continue on reverse side if necessary and identify by block number) Back pressure Saturation (Soils) Back pressure saturation Triaxial shear tests R tests (Soils)		
20. ABSTRACT (Continue on reverse side if necessary and identify by block number) Corps of Engineers (CE) soil laboratories achieve 100 percent saturation of R and R triaxial compression test specimens by the use of back pressure applied in small increments concurrently with increase in chamber pressure with adequate time between increments to permit equalization of pore-water pressure throughout the specimen. The objective of this procedure is to apply sufficient pressure on the pore water and pore air so that the air is dissolved in (Continued)		

028 100

cont
mt

Unclassified

SECURITY CLASSIFICATION OF THIS PAGE(When Data Entered)

20. ABSTRACT (Continued).

cont → the pore water without significantly prestressing (overconsolidating) the specimen. The objectives of this investigation were to determine the effects of the magnitude of back pressure and the procedure by which it is applied on the stress deformation characteristics of soils. The objectives were achieved by comparing results of tests performed on compacted specimens of Vicksburg loess (clayey silt (ML)) and Vicksburg buckshot (plastic clay (CH)) in which the back-pressure saturation procedure was varied and results of tests performed on specimens of Vicksburg buckshot consolidated from a slurry in which the magnitude of the total back pressure was varied. The results indicate that variations in the technique of applying back pressure may significantly affect test results. However, there are no significant effects on test results if procedures outlined in the CE soils testing manual are followed; i.e., results are not significantly affected if the effective consolidation stress during saturation does not exceed 5 psi and the magnitude of back-pressure increments is controlled so that the effective stress on the specimen is less than the desired consolidation pressure. Appendix A presents the back-pressure saturation procedure specified in Engineer Manual 1110-2-1906. Appendices B and C of the report contain descriptions of an automatic back-pressure saturation device that duplicates the saturation procedure outlined in the CE soils testing manual and of a differential vacuum saturation procedure that enables specimens to be saturated using back pressures equal to field hydrostatic conditions, respectively.

Unclassified

SECURITY CLASSIFICATION OF THIS PAGE(When Data Entered)

THE CONTENTS OF THIS REPORT ARE NOT TO BE
USED FOR ADVERTISING, PUBLICATION, OR
PROMOTIONAL PURPOSES. CITATION OF TRADE
NAMES DOES NOT CONSTITUTE AN OFFICIAL EN-
DORSEMENT OR APPROVAL OF THE USE OF SUCH
COMMERCIAL PRODUCTS.

Accession For	
NTIS GRA&I	<input checked="" type="checkbox"/>
DDC TAB	<input type="checkbox"/>
Unannounced	<input type="checkbox"/>
Justification	
By _____	
Distribution/_____	
Availability Codes	
Dist	Avail and/or special
A	

PREFACE

The investigation reported herein was conducted as a part of a study to evaluate laboratory testing procedures for the Office, Chief of Engineers, U. S. Army, under CWIS 174 (formerly Engineering Study (ES) 516) of the Engineering Studies Program. The testing was performed during the period January through September 1975.

The saturation apparatus was designed and fabricated in the Geotechnical Laboratory (GL), at the U. S. Army Engineer Waterways Experiment Station (WES), CE, by Messrs. Robert T. Donaghe and Thomas V. McEwen. The study was conducted by Mr. Donaghe under the supervision of Dr. F. C. Townsend, Former Chief, Soils Research Facility, Soil Mechanics Division (SMD), GL, and the general direction of Mr. C. L. McAnear, Chief, SMD, GL. Messrs. J. P. Sale and R. G. Ahlvin were Chief and Assistant Chief, respectively, GL. This report was prepared by Mr. Donaghe and Dr. Townsend.

COL G. H. Hilt, CE, and COL J. L. Cannon, CE, were Directors of the WES during the investigation and the preparation of this report. Mr. F. R. Brown was Technical Director.

CONTENTS

	<u>Page</u>
PREFACE	2
CONVERSION FACTORS, U. S. CUSTOMARY TO METRIC (SI)	
UNITS OF MEASUREMENT	4
PART I: INTRODUCTION	5
Purpose and Scope	5
Background Information	5
PART II: TESTING PROGRAM AND MATERIALS	8
Testing Program	8
Materials	8
Description of Equipment	9
Preparation of Specimens	12
Testing Procedure	13
PART III: TEST RESULTS AND DISCUSSION	18
Effects of Magnitude of Back-Pressure Increments, ML Material	18
Effect of Magnitude of Effective Stress Induced by Back Pressure, CH Material	21
Effect of Magnitude of $\bar{\sigma}_c$ During Saturation, CH and ML Materials.	25
Effect of Magnitude of Total Back Pressure	34
CH Material Consolidated from a Slurry	39
PART IV: CONCLUSIONS AND RECOMMENDATIONS	42
Compacted Specimens, $\bar{\sigma} = 7.1$ psi (0.5 kg/cm ²)	42
CH Specimens Consolidated from a Slurry, $\bar{\sigma}_c = 7.0$ and 56.9 psi (0.5 and 4.0 kg/cm ²)	43
Test Equipment and Procedures	43
TABLES 1-4	
APPENDIX A: BACK-PRESSURE SATURATION PROCEDURE SPECIFIED IN ENGINEER MANUAL 1110-2-1906	A1
APPENDIX B: OPERATION OF AUTOMATIC BACK-PRESSURE SATURATION APPARATUS AND PRESSURE CONTROL SYSTEM	B1
Controlled Magnitude of Effective Stress Induced by Back-Pressure Procedure	B1
Controlled Magnitude of Back-Pressure Increment Procedure	B3
APPENDIX C: DIFFERENTIAL VACUUM SATURATION PROCEDURE	C1

CONVERSION FACTORS, U. S. CUSTOMARY TO METRIC (SI)
UNITS OF MEASUREMENT

U. S. customary units of measurement used in this report can be converted to metric (SI) units as follows:

<u>Multiply</u>	<u>By</u>	<u>To Obtain</u>
inches	2.54	centimetres
pints (U. S. liquid)	0.4731765	cubic decimetres
pounds (force) per square inch	6894.757	pascals
pounds (mass)	0.4536	kilograms
pounds (mass) per cubic foot	16.0185	kilograms per cubic metre

EFFECTS OF BACK-PRESSURE SATURATION TECHNIQUES ON
RESULTS OF \bar{R} TRIAXIAL COMPRESSION TESTS

PART I: INTRODUCTION

1. The use of back pressures to insure complete saturation of test specimens is a widely used procedure. Accordingly, in Corps of Engineers (CE) soil laboratories, saturation of R and \bar{R} triaxial compression test specimens is achieved by use of back pressures applied according to procedures given in Engineer Manual 1110-2-1906.* The objective of this procedure is to apply pressure on the pore water and pore air, together with an increase in chamber pressure, so that the air is dissolved in the pore water and the difference between the chamber pressure and the back pressure remains approximately constant; i.e., the effective consolidation pressure during saturation remains unchanged.

Purpose and Scope

2. The objectives of this investigation were to verify back-pressure procedures outlined in EM 1110-2-1906 by determining the effects of the magnitude of back pressure and the procedure by which it is applied on the measured triaxial compression strengths of soils.

3. The objectives were achieved by comparing results of tests performed on compacted specimens of a plastic clay (CH) and a clayey silt (ML) in which the back-pressure saturation procedure was varied and results of tests performed on specimens of the plastic clay (CH) consolidated from a slurry in which the magnitude of the total back pressure was varied.

Background Information

4. The CE back-pressure saturation procedure given in Engineer

* Department of the Army, Office, Chief of Engineers, "Engineering and Design: Laboratory Soils Testing," Engineer Manual 1110-2-1906, 30 Nov 1970, Washington, D. C.

Manual 1110-2-1906* and outlined in Appendix A basically consists of increasing the back pressure in small increments while concurrently increasing the chamber pressure, with adequate time between increments to permit equalization of pore-water pressure throughout the specimen. An increment is added when the pore pressure measured at the base of the specimen becomes essentially constant under the previous increment of back pressure. The magnitude of each increment typically varies between 5 and 20 psi,** depending on the compressibility of the soil specimen and the magnitude of the desired consolidation pressure. Specimens are considered to be completely saturated when a chamber pressure increment of about 5 psi, applied to the specimen with the drainage lines closed, results in an immediate and equal increase in pore pressure.

5. In June 1964, samples of three different soils, termed "standard soil samples," were sent from the U. S. Army Engineer Waterways Experiment Station (WES) to nine CE division soils laboratories to determine the variation in test results when different laboratories performed the same tests on the same soils. Among the tests were \bar{R} triaxial compression tests to be performed using procedures given in Engineer Manual 1110-2-1906.† Results of the \bar{R} tests, as reported in Miscellaneous Paper (MP) 3-813,†† indicated a wide variation in the measured shear strengths. In an attempt to determine factors that may have caused the variations, the following aspects of saturation procedures were reviewed:

- a. Procedures used in applying back pressure, i.e., magnitude and duration of back-pressure increments that might indicate possible prestressing.
- b. Magnitude of effective consolidation pressure during saturation, which might indicate conditions permitting the specimen to swell.

* Engineer Manual 1110-2-1906, Appendix X, pp 33-35, op. cit.

** A table of factors for converting U. S. customary units of measurement to metric (SI) units is present on page 4.

† Engineer Manual 1110-2-1906, Appendix X, pp 29-38, op. cit.

†† Strohm, W. E., Jr., "Preliminary Analysis of the Results of Division Laboratory Tests on Standard Soil Samples," Miscellaneous Paper 3-813, Apr 1966, U. S. Army Engineer Waterways Experiment Station, CE, Vicksburg, Miss.

- c. Total time for saturation, which might indicate possible thixotropic effects.

The data presented in Table 1 show that there were significant differences in saturation procedures among the various laboratories. Unfortunately, a determination of the effect of back-pressure saturation techniques on the measured strengths was impossible, since other variations in testing procedures, techniques, and test conditions (such as variations in initial specimen conditions, methods of compaction, rate of axial loading, and variations in pore-pressure measurement devices) masked any conclusive trends.

PART II: TESTING PROGRAM AND MATERIALS

Testing Program

6. The testing program consisted of two parts. The first part was a series of tests performed on compacted specimens, and the second part consisted of a series of tests performed on specimens trimmed from a sample consolidated from a slurry. The variables that were investigated in the testing program are shown in Table 2.

Part 1

7. Tests in Part 1 of the testing program given in Table 2 consisted of \bar{R} triaxial tests performed on compacted specimens of the standard ML and CH soils to determine effects on the strength-deformation characteristics of the materials due to varying the saturation procedure. Since these tests were performed at water contents favoring dilative tendencies, it was hoped that the influence of the variables that were investigated (i.e., magnitude of back-pressure increments, magnitude of $\bar{\sigma}_c$ during saturation, etc.) would be more pronounced.

Part 2

8. Part 2 of the testing program (the variables that were investigated are shown in Table 3) consisted of two series of \bar{R} triaxial tests performed on specimens trimmed from a sample of CH material consolidated from a slurry under a maximum vertical consolidation pressure, $\bar{\sigma}_p$, of 3 kg/cm^2 . Effective consolidation pressures, $\bar{\sigma}_c$, were 0.5 and 4.0 kg/cm^2 for the first and second series, respectively. Total back-pressure magnitudes for the $\bar{\sigma}_c = 0.5 \text{ kg/cm}^2$ tests were 80, 120, and 160 psi and those for the $\bar{\sigma}_c = 4.0 \text{ kg/cm}^2$ tests were 60, 80, and 120 psi. The purpose of the tests was to determine effects of the magnitude of total back pressure on the strength and deformation characteristics of both normally and over-consolidated clay, approximating undisturbed specimens.

Materials

9. The two soils tested in this investigation were Vicksburg loess

(clayey silt (ML)) and Vicksburg buckshot (clay (CH)). Both soils (commonly referred to as "standard soils") were taken from material that had been processed for use in the investigation of variations in test results when different laboratories perform the same tests on identical soils.* Some properties of the soils as determined by the Lower Mississippi Valley Division Laboratory are:

	<u>Vicksburg Loess (ML)</u>	<u>Vicksburg Buckshot (CH)</u>
Liquid limit	28	59
Plastic limit	24	22
Plasticity index	4	37
Specific gravity	2.72	2.69
Standard maximum dry unit weight, pcf	105.7	98.4
Standard optimum water content, percent	16.6	21.9

Description of Equipment

10. Figure 1 shows the triaxial equipment utilized for the investigation. A schematic diagram of the testing apparatus is given in Figure 2. Chamber and back pressures were applied using compressed air controlled by pneumatic pressure regulators. All pneumatic pressures were measured with Bourdon tube gages. Pore-water pressures were measured with electronic differential pressure transducers. The force applied to the piston was measured using an electronic load cell. Transducers, load cells, and gages were calibrated so that all pressures and stresses were accurate to within $\pm 0.02 \text{ kg/cm}^2$. Changes in height of the specimen during shear were measured with a displacement potentiometer calibrated to the nearest 0.001 in. During shear, load cell, pore-pressure transducer, and displacement potentiometer readings were automatically recorded by a digital recorder. Changes in height of the specimen during consolidation were measured with a dial indicator reading 0.01 mm/division. De-aired distilled water was used to saturate the specimen and also for the chamber fluid. The volume of water

* Strohm, op. cit.

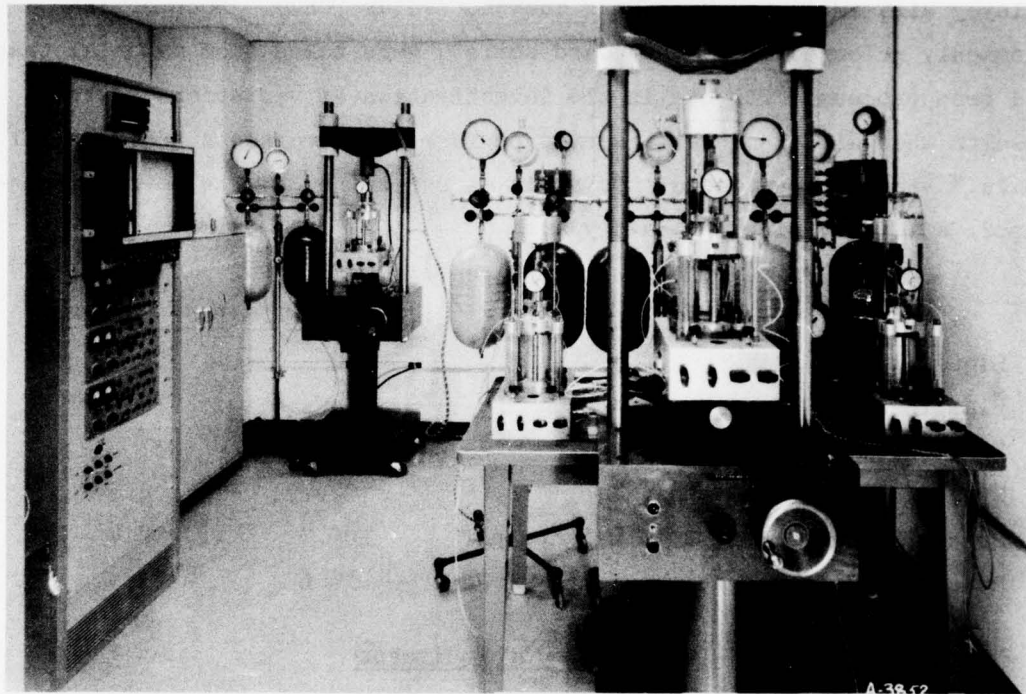

Figure 1. Triaxial testing facility

entering and leaving the specimen during saturation and consolidation was measured using glass burettes reading 0.1 cc/division. Filter strips made from Whatman No. 1 Chromatography paper were evenly spaced around the periphery of the specimen and extended from the top of the specimen to within 0.7 in. of the bottom. Fifty percent of the specimen's periphery was covered by the strips. Porous discs at the top and bottom of the specimen were made of sintered stainless steel and were approximately the same diameter as the specimen. The slurry consolidometer utilized in the investigation for Part 2 CH specimens was designed and fabricated at Northwestern University in Evanston, Illinois. A description of the consolidometer is given in a report of operational procedures by Krizek and Sheeran.*

* R. J. Krizek and D. E. Sheeran, "Operational Procedure for Slurry Consolidometer," Contract Report S-70-6, Report 1, Jun 1970, Northwestern University Technological Institute, Contract No. DACW 39-70-C-0053, Evanston, Ill.

Preparation of Specimens

11. The desired initial specimen conditions for tests in Part 1 of the testing program were water contents of 14.6 and 24.5 percent and dry unit weights of 100.4 and 93.5 pcf for the ML and CH materials, respectively. These conditions correspond to approximately 95 percent of standard maximum density for both materials and optimum +2 percent and optimum -2 percent water content for the ML and CH materials, respectively. The average water content of the CH material consolidated from a slurry to be tested in Part 2 of the testing program was 29.9 percent. Batches for compacted specimens of each soil were prepared in a humid room by mixing a previously determined amount of air-dried soil with sufficient distilled water to obtain the desired water content. After mixing, the batches were split into portions sufficient for individual specimens. Each portion was placed in an airtight 1/2-pt glass jar and allowed to cure for at least 7 days. The buckshot slurry was prepared by sifting a predetermined amount of air-dried soil through a No. 60 sieve into a container containing sufficient boiling, de-aired, distilled, demineralized water to obtain a water content approximately 1.5 times the liquid limit. Boiling, de-aired water was used to keep the amount of air in the slurry at a minimum during the preparation procedure. The amount of air-dried soil was computed by assuming a final consolidated sample height of 5 in.

12. Compacted specimens of both soils were molded in a 1.4-in.-diam by 3.5-in.-high split mold, using a modified Berkeley pneumatic tamper. A description of the tamper is given in Miscellaneous Paper 3-478,* a report of an evaluation of soil mechanics laboratory equipment. The specimens were compacted in eight layers using 30 tamps (three complete coverages of the surface area) on each layer. Approximately

* B. N. MacIver and R. T. Donaghe, "Evaluation of Soil Mechanics Laboratory Equipment; Modified Berkeley Pneumatic Tamper for Compacting Test Specimens of Cohesive Soils," Miscellaneous Paper 3-478, Report 12, Jun 1971, U. S. Army Engineer Waterways Experiment Station, CE, Vicksburg, Miss.

one-half of the uppermost layer was trimmed away to obtain the desired 3-in. specimen height. Specimens from the slurry consolidated sample were trimmed to a diameter of 1.4 in. by use of a soil lathe. The ends were squared using a 3-in.-high miter box. After the wet weight of each specimen was obtained and moistened filter strips were in place, each specimen was encased in two standard 0.003-in.-thick rubber membranes separated by a layer of silicone grease. The membranes were sealed at the cap and base using two O-rings each. In the case of the CH specimens, a thin coating of silicone grease was placed on the outside of the specimen below the filter strips to eliminate the possibility of short circuiting between the ends of the strips and the bottom porous stone.

Testing Procedure

Saturation

13. Prior to applying back pressure, specimens of the ML material were placed under a partial vacuum of 5 psi applied through burette No. 2 (see Figure 2) to the top of the specimen. After differential pressure transducer readings indicated an equilibrium condition under the partial vacuum, the bottom of the specimen was allowed access to de-aired water in burette No. 1 under atmospheric pressure, thereby allowing water to seep from the bottom to the top of the specimen, hopefully pushing air in front of it. When water appeared at the bottom of burette No. 2, an additional 2 cc of water were allowed to seep through the specimen. The valve to the top of the specimen was then closed, and a full vacuum was applied to burette No. 2 so that the system to be used to back pressure the specimen could be de-aired. After the system was de-aired, the vacuum was released, and the burette was filled with sufficient de-aired water to saturate the specimen. A chamber pressure of 5 psi was then applied with the valve to the top of the specimen open, and the appropriate back-pressure procedure was initiated. In the case of the CH specimens, vacuum was not applied to the specimens; hence, the procedure followed prior to applying back pressure was much shorter. A

chamber pressure of 5 psi was applied, and the appropriate back-pressure saturation procedure was initiated with the valve to the top of the specimen open to burette No. 2, which had previously been filled with sufficient de-aired water to achieve saturation.

14. Back pressures were automatically applied to specimens of both soils using the apparatus diagramed in Figure 2. The apparatus was designed to operate in two modes. In the first mode, the apparatus automatically increased the back pressure at the top of the specimen until the differential pressure between the top and bottom of the specimen reached a maximum preset value. The back pressure was then held constant until the differential pressure was dissipated, at which point it was again increased until the maximum differential pressure was once again developed. This operation was repeated until the maximum preset total back pressure was attained. (The chamber pressure was increased automatically as the back pressure was increased.) For example, initially the back pressure for specimen 4 was automatically increased until the difference in pressure between top and bottom was 5.0 psi. The pressure was then held constant until the differential dissipated to 0.5 psi at which time the pressure to the specimen top was again automatically increased until a differential of 5.0 psi was once more achieved. As saturation of the specimen proceeded, the magnitude of back pressure required to develop the 5.0-psi differential increased; and finally, because the pressure response at the bottom of the specimen was such that an increase in back pressure could not develop the 5.0-psi differential, the back pressure increased to the maximum preset value. Thus in the case of specimen 4, the differential across the specimen never exceeded 5.0 psi. In the case of specimens 5 and 6, the differential never exceeded 10 or 20 psi, respectively. After the total preset back pressure was applied, the pressures were maintained until a check of B pore-pressure parameter ($B = \Delta u / \Delta \sigma_3$) could be made. In this mode of operation, the following variables were investigated:

- a. The magnitude of the induced effective stress (the difference between the back pressure applied to the top of the specimen and the induced pore pressure measured at the bottom) during saturation.

- b. The magnitude of the effective consolidation pressure (chamber pressure minus back pressure) during saturation.
- c. The magnitude of the total back pressure at the end of the saturation procedure.

In the second mode of operation, effects of the magnitude of back-pressure increments were investigated. The magnitude of the increments was controlled by relays that opened solenoid valve B (see Figure 2) and closed solenoid valve A when the signal from differential pressure transducer No. 2 indicated a pressure equal to the desired increment. When the differential pressure between the top and bottom of the specimen occurring as a result of the back-pressure increment was dissipated, another back-pressure increment was applied. This operation was repeated until the total predetermined total back pressure was applied, whereupon the pressures were maintained until a B check could be made. For example, in the case of specimen 1, a back-pressure increment of 5.0 psi was applied to the specimen top. When the pressure differential between the specimen top and bottom reached approximately zero (0.5 psi), the next 5.0-psi increment was applied. In this manner, when the specimen approached saturation, the pressure differential reached 0.5 psi almost instantaneously after application of a back-pressure increment and the controlling relays cycled back and forth rapidly. However, the final increment applied never exceeded 5.0 psi for specimen 1 or 10 and 20 psi for specimens 2 and 3, respectively. This procedure duplicates that prescribed by Engineer Manual 1110-2-1906. Additional information concerning saturation procedures using the apparatus is given in Appendix B.

15. After the maximum preset back pressure had been applied, the pore-pressure parameter B was measured by closing the valve to the top of the specimen and raising the chamber pressure by 10 psi, while observing the corresponding pore-pressure response at the bottom of the specimen. (Previous experience has shown that erroneous pore-water pressure responses can be obtained if the pore-pressure transducer is in direct communication with the filter strips through the top of the specimen, since there is usually sufficient free water in the strips to

give an immediate and equal response to the increase in chamber pressure even though the specimen may not be completely saturated.) For the ML specimens, pore-pressure responses were almost immediate with B values ranging from 0.98 to 1.00 (Table 4). In the case of CH specimens, B values ranged from 0.96 to 1.00 (Table 4) with complete response often requiring from 5 to 10 min. The maximum time for saturation was 1 day for ML specimens and 3 days for CH specimens.

Consolidation

16. Specimens were consolidated in one increment by increasing the chamber pressure to the desired difference between the chamber pressure and back pressure (effective consolidation pressure, $\bar{\sigma}_c$). Valves to the top and bottom of the specimen were then opened, allowing water to drain from the specimen into the burette. Each specimen was consolidated for at least 24 hr after completion of primary consolidation. Consolidation times for the CH specimens consolidated under an effective pressure of 0.5 kg/cm² averaged 2 days, while those consolidated under an effective pressure of 4.0 kg/cm² averaged 3 days.

Shear

17. Upon completion of consolidation, the vertical height indicator was read and the valves to the top and bottom of the specimen were closed. Specimens were then axially loaded at a constant rate of strain (0.12 percent/min for the ML specimens and 0.012 percent/min for the CH specimens). When the specimen had been deformed to slightly more than 15 percent strain, the test was stopped and the chamber and back pressures were removed with the valves to the top and bottom of the specimen remaining closed. After draining the chamber fluid, the membranes covering the specimen were removed and the specimen was placed in an aluminum container for a water-content determination.

PART III: TEST RESULTS AND DISCUSSION

18. Results of the 26 \bar{R} triaxial tests performed on the two soils are summarized in Table 4 and are presented graphically in Figures 3 through 19. The tests are grouped in the table and figures according to the variables investigated.

Effects of Magnitude of Back-Pressure Increments, ML Material

19. Figure 3 presents deviator stress and induced pore pressure versus axial strain curves for tests performed on ML specimens back pressured using mode 2 to determine the effects of varying the magnitude of back-pressure increments from 5 to 20 psi. While EM 1110-2-1906 allows these magnitudes of back-pressure increments, it is quite possible prestressing could occur if this magnitude exceeds the consolidation stress. The effect of back-pressure increment magnitude on deviator stress and induced pore pressures at 15 percent strain are presented in Figure 4. These comparisons show that increasing the magnitude of back-pressure increments from 5 to 10 psi had little effect on either deviator stresses or induced pore pressures. There was, however, a significant change in both deviator stresses and induced pore pressures taken at 15 percent strain when the magnitude of back-pressure increments was increased from 10 to 20 psi. For this range, the deviator stresses at failure were increased by approximately 12 percent, and the corresponding induced pore pressures were reduced approximately 18 percent. Since the consolidation pressure at shear, $\bar{\sigma}_{3c}$, was only 0.5 kg/cm^2 (7.1 psi), the initial 20-psi back-pressure increments most likely prestressed the specimen significantly, causing slightly lower water contents and corresponding higher strengths and lower induced pore pressures. The relationship between deviator stresses at failure and final water contents for ML specimens given in Figure 5 shows that the strength of ML specimens is very sensitive to small differences in final water content with a 0.1 percent difference in final water content, resulting in a 0.3-kg/cm^2 difference in the

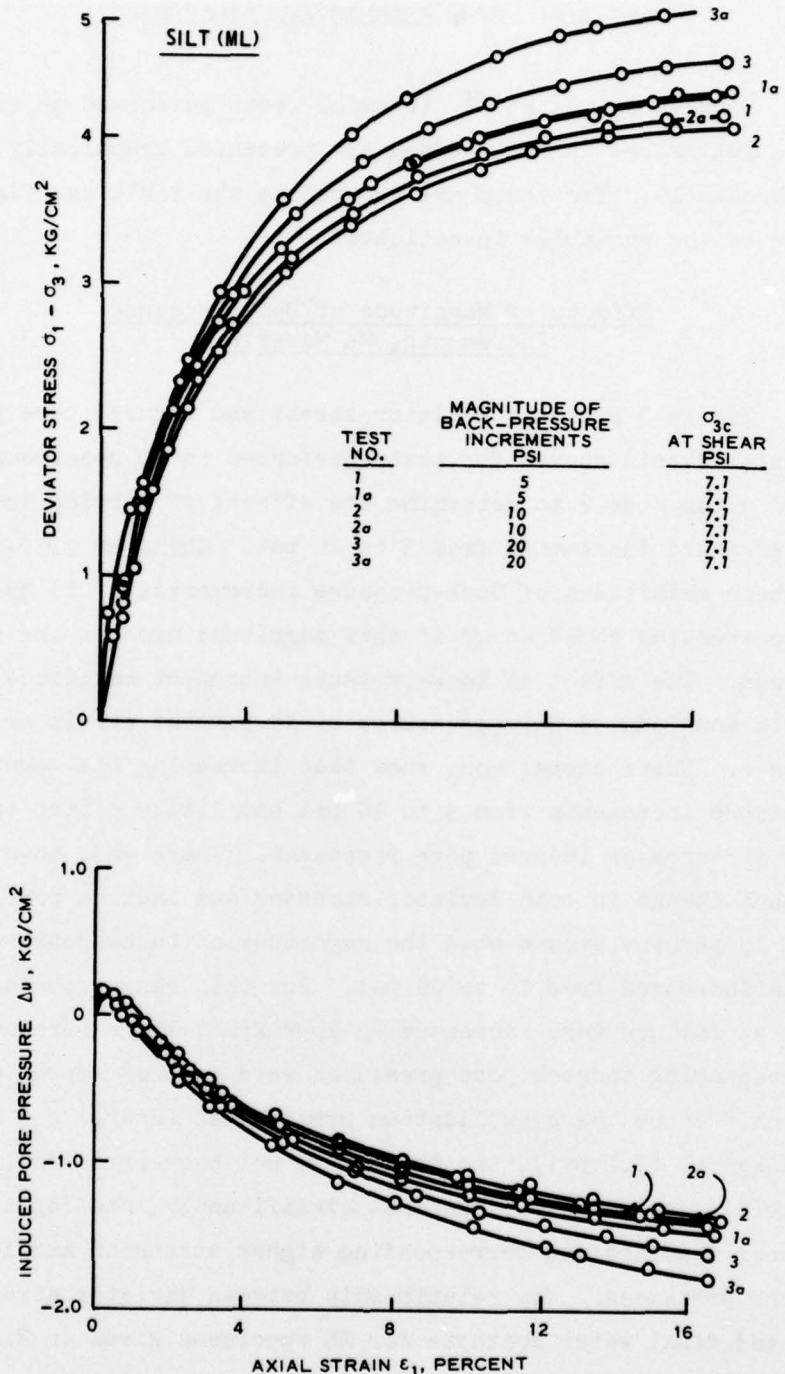

Figure 3. Deviator stress and induced pore pressure versus axial strain curves for tests in which the magnitude of back-pressure increments was varied, ML specimens

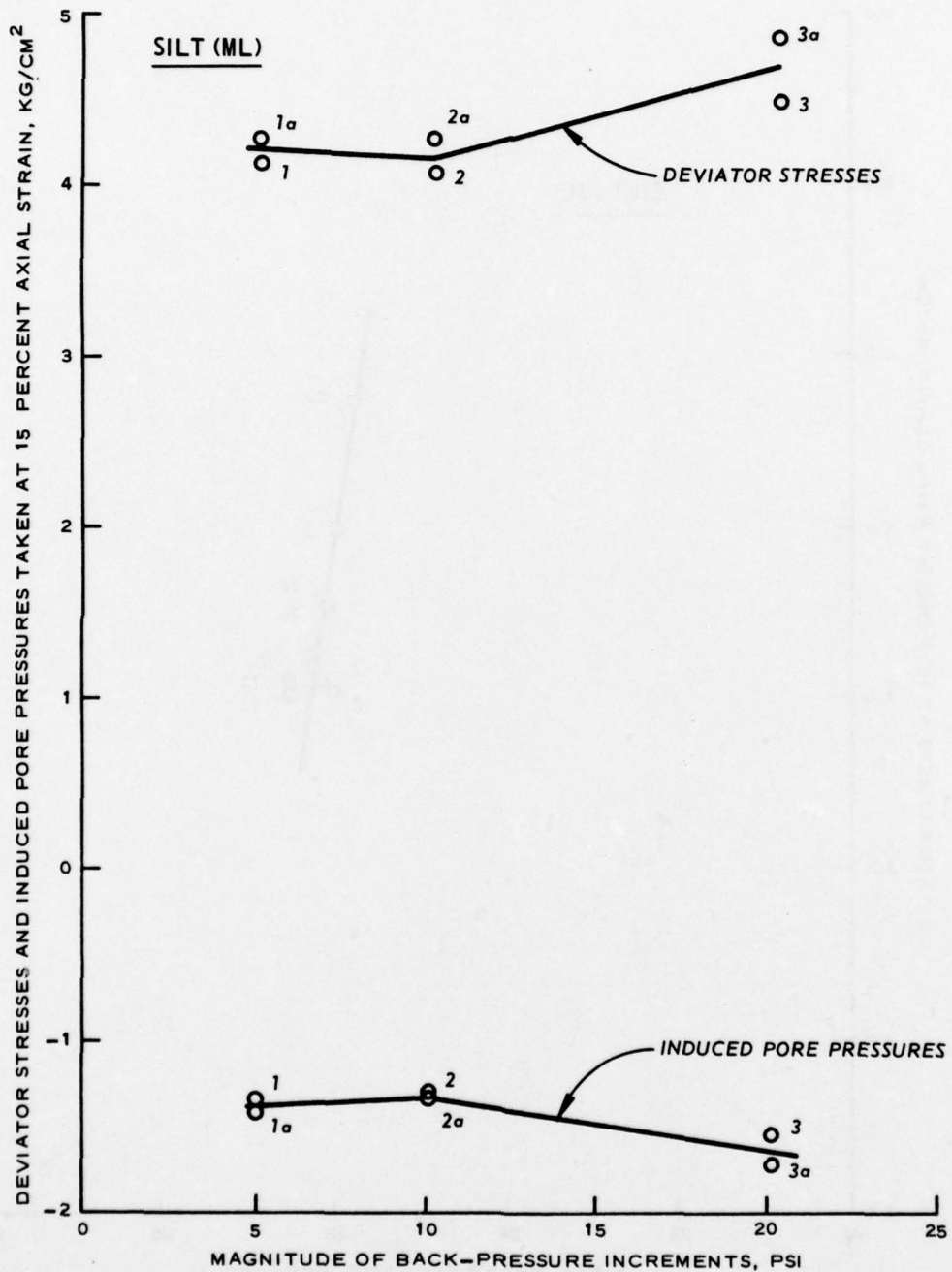

Figure 4. Deviator stresses and induced pore pressures taken at 15 percent axial strain versus magnitude of back-pressure increments, ML specimens, $\bar{\sigma}_{3c} = 0.5 \text{ kg/cm}^2$ (7.1 psi)

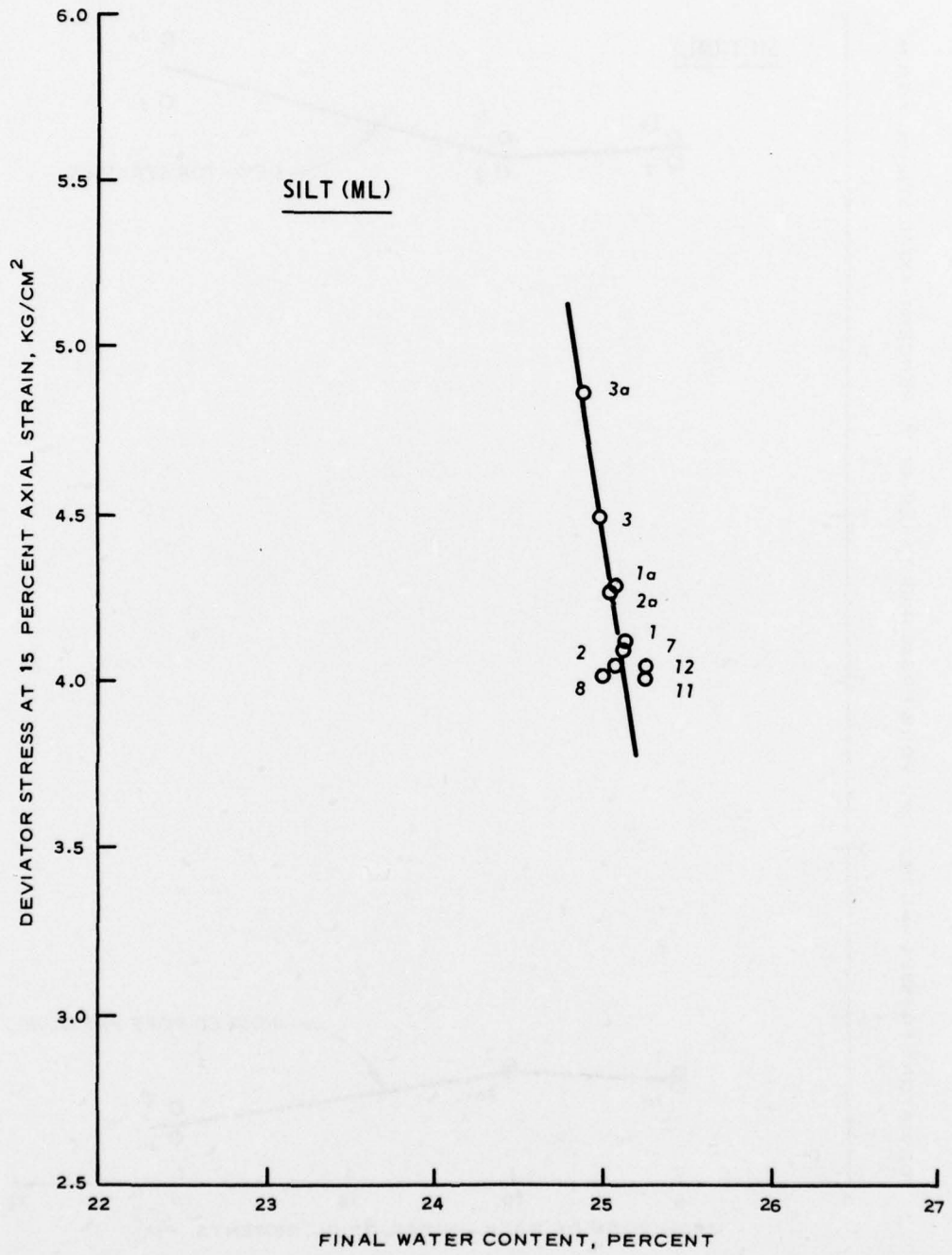

Figure 5. Deviator stress at 15 percent axial strain versus final water content, ML specimens

deviator stress at failure. The pore-pressure parameter A versus magnitude of back-pressure increment plot given in Figure 6 shows that greater negative A values were developed for the specimens saturated using 20-psi back-pressure increments. It may be noted that greater negative values of A would also occur for more dense specimens such as might result from prestressing specimens during the saturation procedure. Thus, the allowing of back-pressure increments in excess of $\bar{\sigma}_{3c}$ could cause prestressing.

Effect of Magnitude of Effective Stress
Induced by Back Pressure, CH Material

20. Plots of deviator stress and induced pore pressure versus axial strain for tests performed on CH material back pressure saturated using mode 1 in which the maximum difference between applied back pressure and induced pore pressure measured at the base of the specimen was varied from 5 to 20 psi are given in Figure 7. Since the saturation apparatus allowed this difference to be controlled, it was hoped that results of these tests could be used to determine the extent to which specimens might be prestressed during saturation without significantly affecting test results. The stress-strain curves show that in all cases deviator stresses increased rapidly to an axial strain value of approximately 1 percent and then after either decreasing slightly or almost leveling off began to increase gradually at strains of from 2 to 4 percent and continued to increase until the end of the tests. (This increase was probably due to dilative tendencies causing pore-pressure decreases and a corresponding increase in strength.) Since this initial yield would most likely reflect effects due to prestressing specimens during saturation, failure was assumed to have occurred at an axial strain value of 2 percent. Effects of induced effective stresses occurring during saturation are shown in Figure 8, which shows deviator stresses and induced pore pressures at failure versus the magnitude of the induced effective stresses. As may be seen, deviator stresses were relatively unchanged by effective stresses up to 10 psi; however, there was an increase in deviator stress of

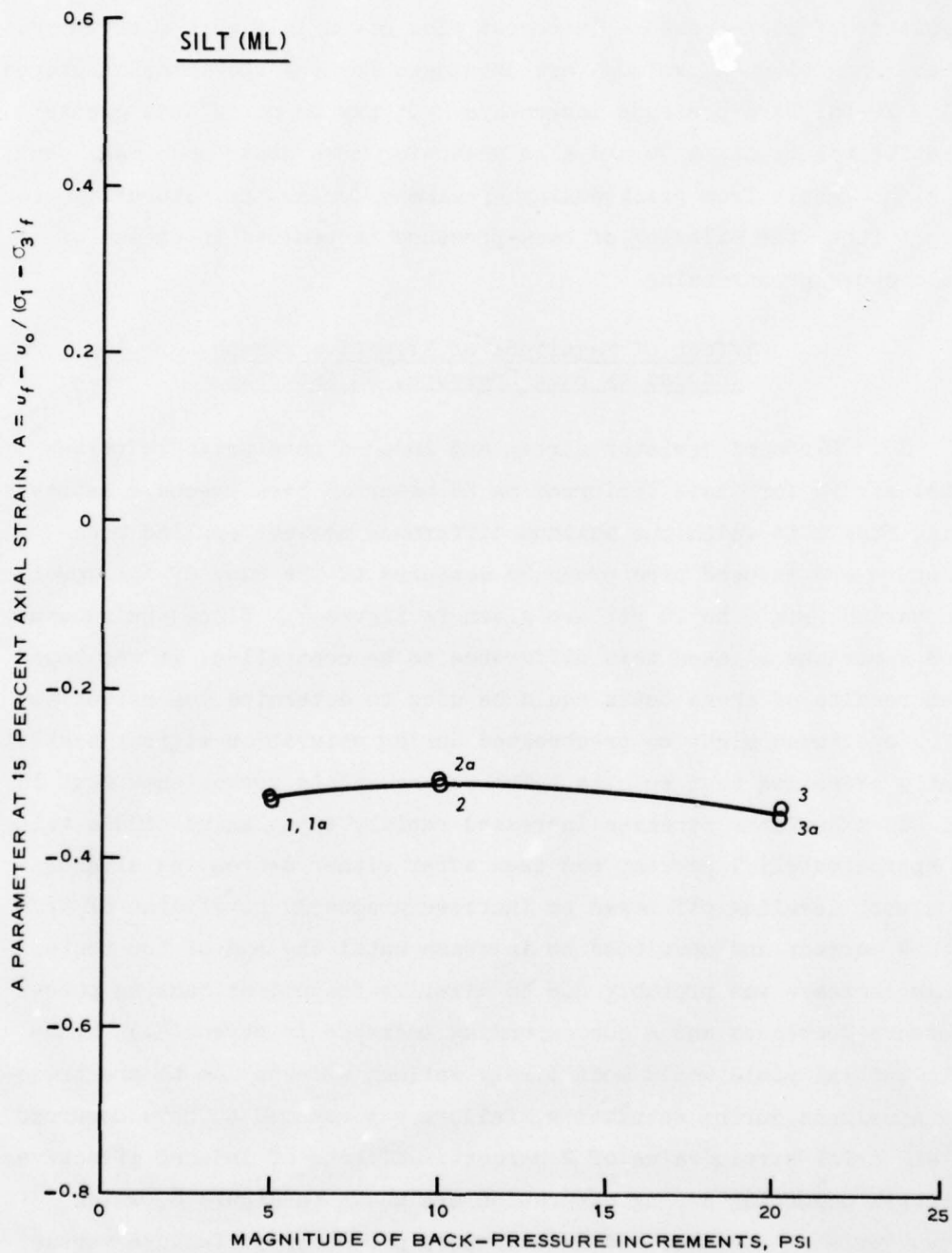

Figure 6. A parameter at 15 percent axial strain versus magnitude of back-pressure increments, ML specimens, $\bar{\sigma}_{3c} = 0.5 \text{ kg/cm}^2$ (7.1 psi)

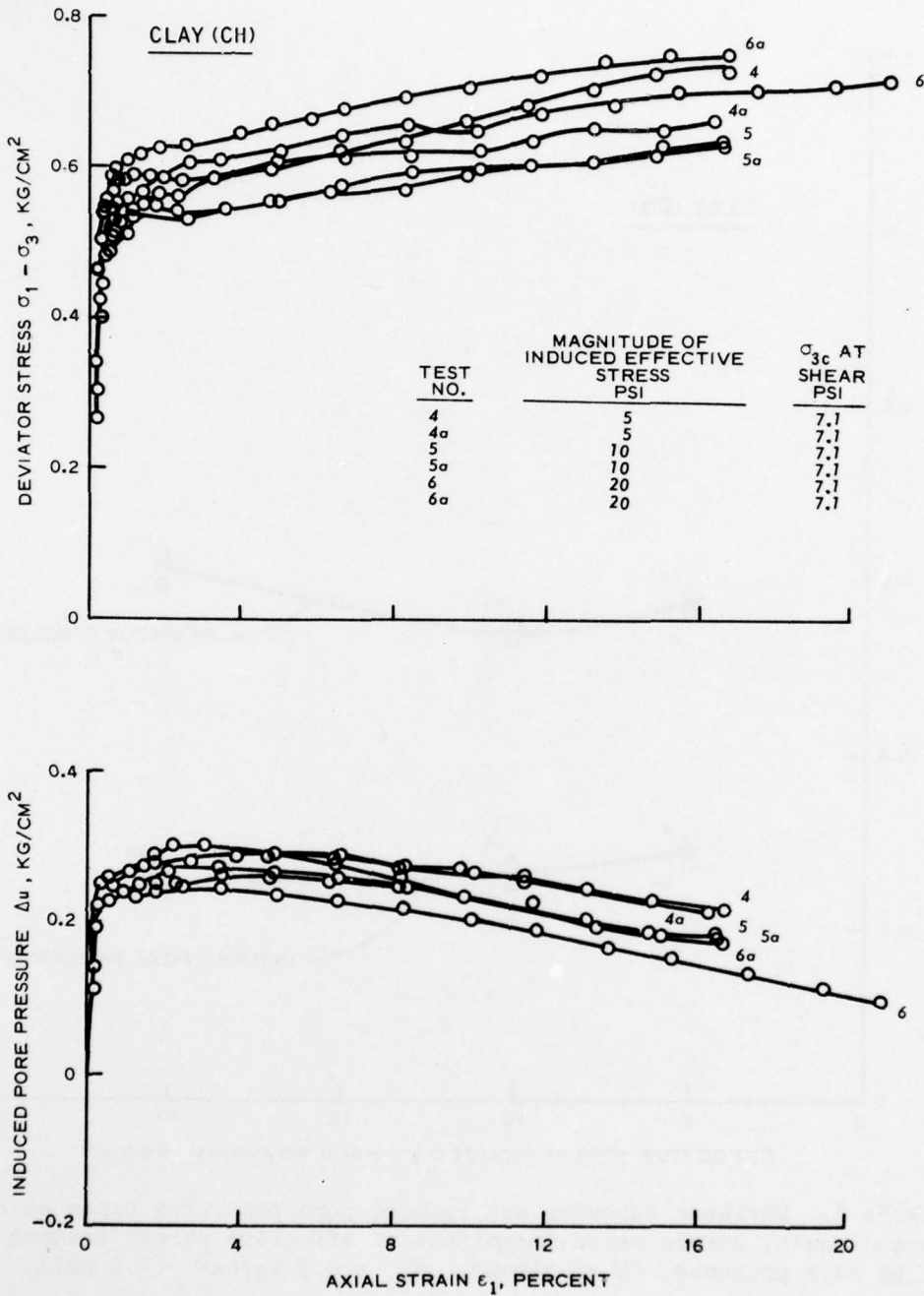

Figure 7. Deviator stress and induced pore pressure versus axial strain curves for tests in which the magnitude of effective stresses induced by back pressure was varied, CH specimens

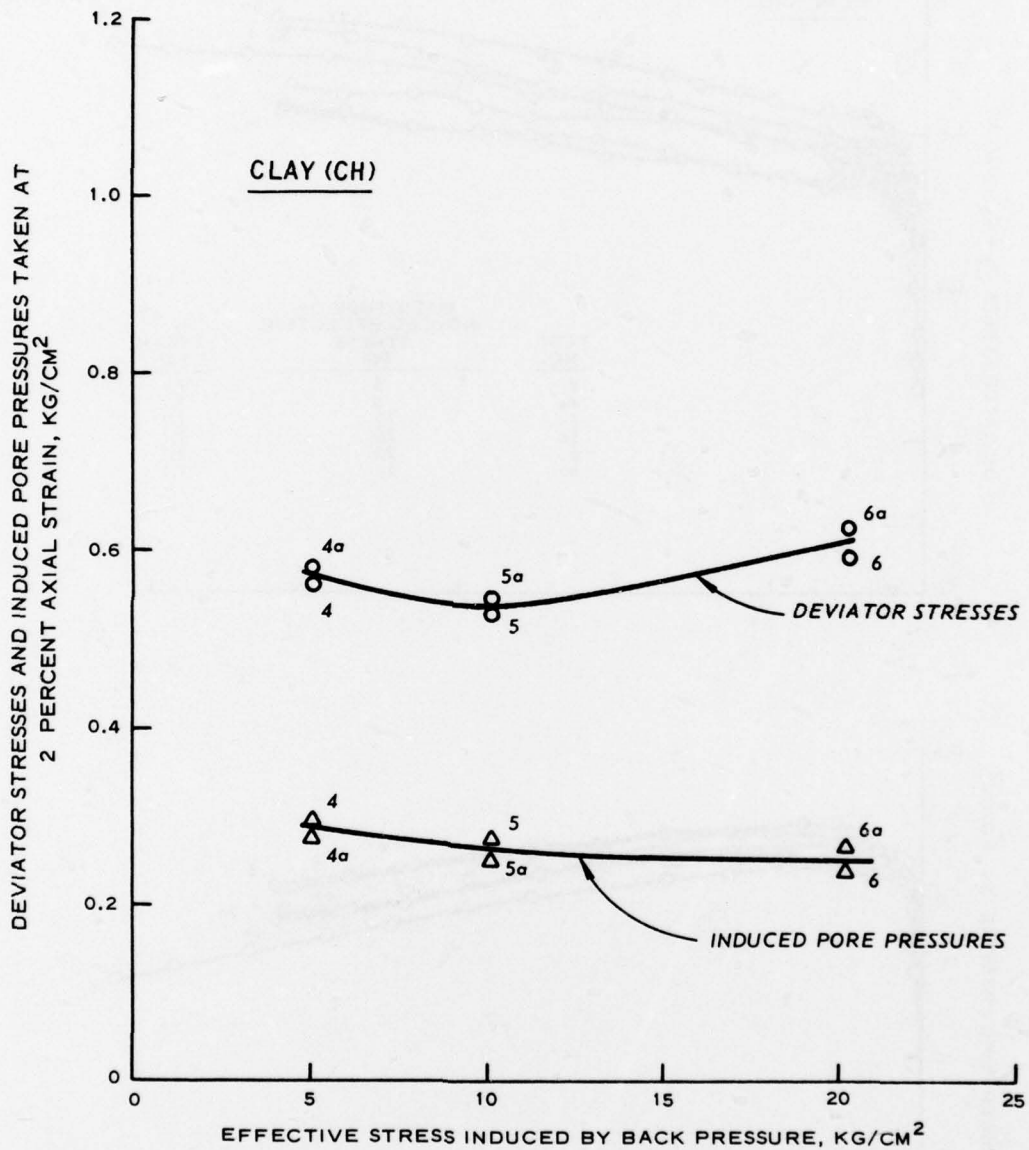

Figure 8. Deviator stresses and induced pore pressures taken at 2 percent axial strain versus magnitude of effective stress induced by back pressure, CH specimens, $\bar{\sigma}_{3c} = 0.5 \text{ kg/cm}^2$ (7.1 psi)

approximately 13 percent when the maximum induced effective stress was increased from 10 to 20 psi. Induced pore pressure, on the other hand, decreased with increasing induced effective stresses up to the maximum effective stress of 20 psi. The decrease in induced pore-water pressure occurring between effective stresses of 5 and 10 psi was approximately 7 percent, while that occurring between effective stresses of 10 and 20 psi was approximately 6 percent. Values of deviator stresses at failure ranged from 0.53 to 0.63 kg/cm², while induced pore pressures varied from 0.30 to 0.24 kg/cm². The relationship between the A parameter taken at failure A_f and induced effective stresses given in Figure 9 indicates that A_f decreases with increasing induced effective stresses with the greatest reduction occurring between effective stresses of 10 and 20 psi. Since the consolidation pressure at shear, $\bar{\sigma}_{3c}$, was only 0.5 kg/cm² (7.1 psi), the initial 20-psi back-pressure increments most likely prestressed and caused overconsolidation of the specimens. Lower A values at failure also reflect a greater degree of overconsolidation, hence the increase in strength noted for specimens saturated under a maximum induced effective stress of 20 psi is attributed to overconsolidation occurring as a result of prestressing the specimens during saturation. Thus, back-pressure increments in excess of $\bar{\sigma}_{3c}$ can cause detrimental prestressing.

Effect of Magnitude of $\bar{\sigma}_c$ During
Saturation, CH and ML Materials

21. The extent to which specimens may be prestressed during saturation also depends, of course, on the effective consolidation stress (chamber pressure minus back pressure), $\bar{\sigma}_c$, acting during the saturation procedure with respect to $\bar{\sigma}_c$ during shear. Deviator stress and induced pore pressure versus axial strain curves for tests in which $\bar{\sigma}_c$ during saturation was varied from 2 to 7 psi are shown in Figures 10 and 11 (back pressure was applied in 5-psi increments for each $\bar{\sigma}_c$). Plots of deviator stresses and induced pore pressures taken at failure (at an axial strain value of 15 percent) versus $\bar{\sigma}_c$ during saturation for the ML specimens given in Figure 12 show that there was no

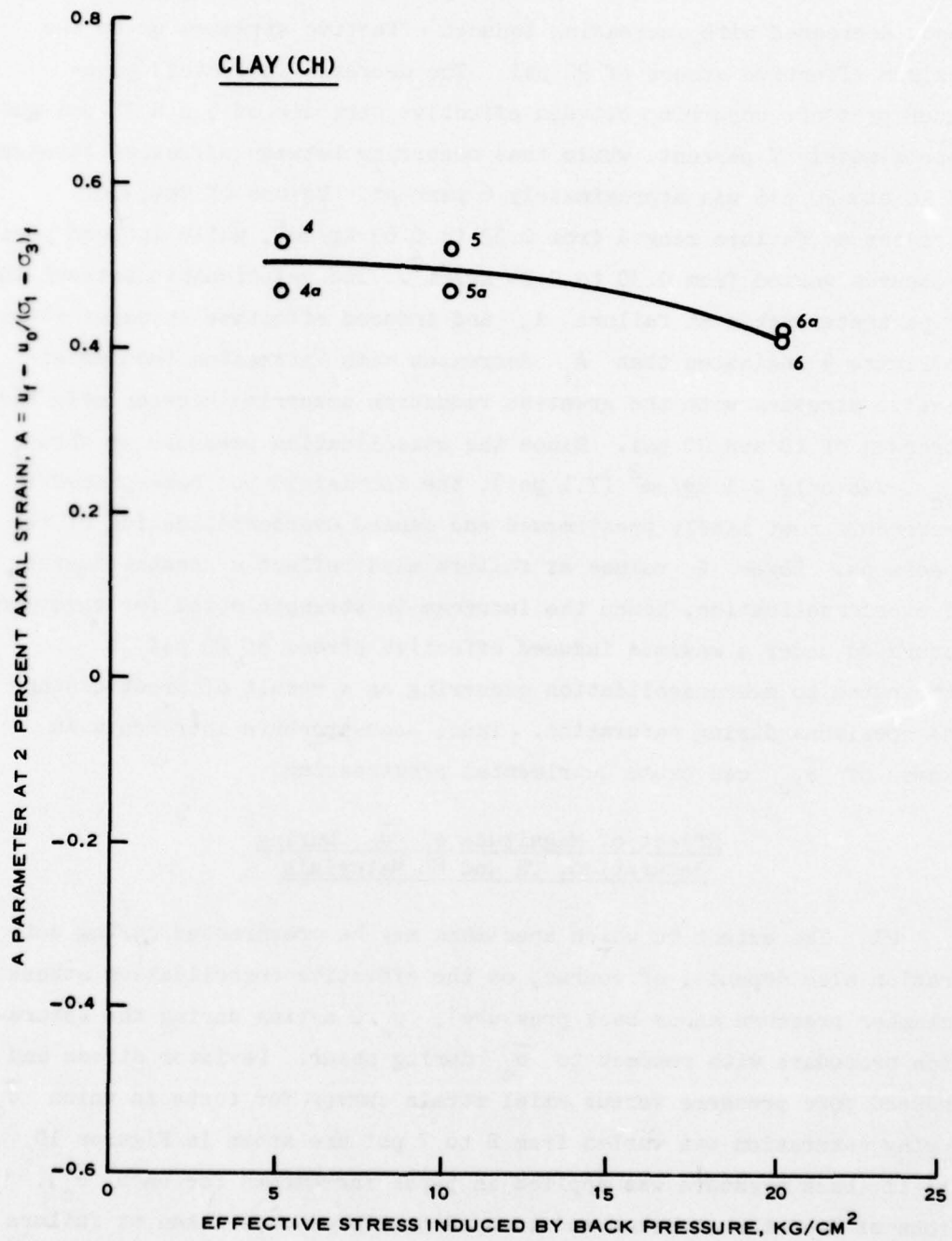

Figure 9. A parameter at 2 percent axial strain versus magnitude of effective stress induced by back pressure, CH specimens

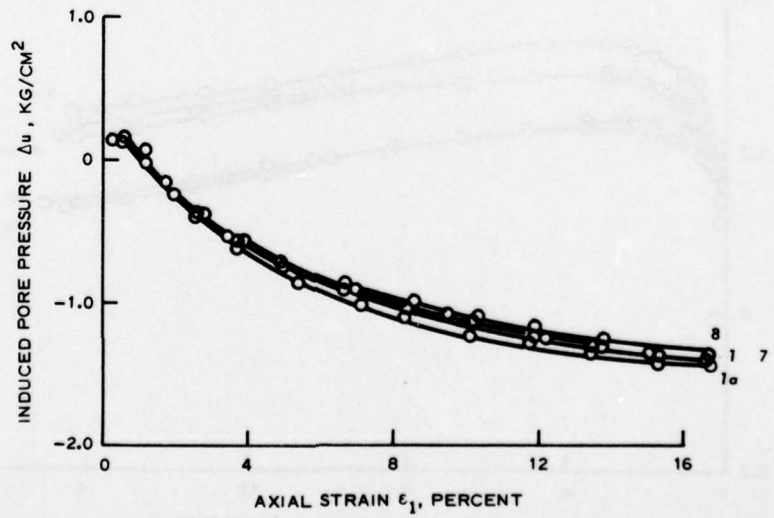
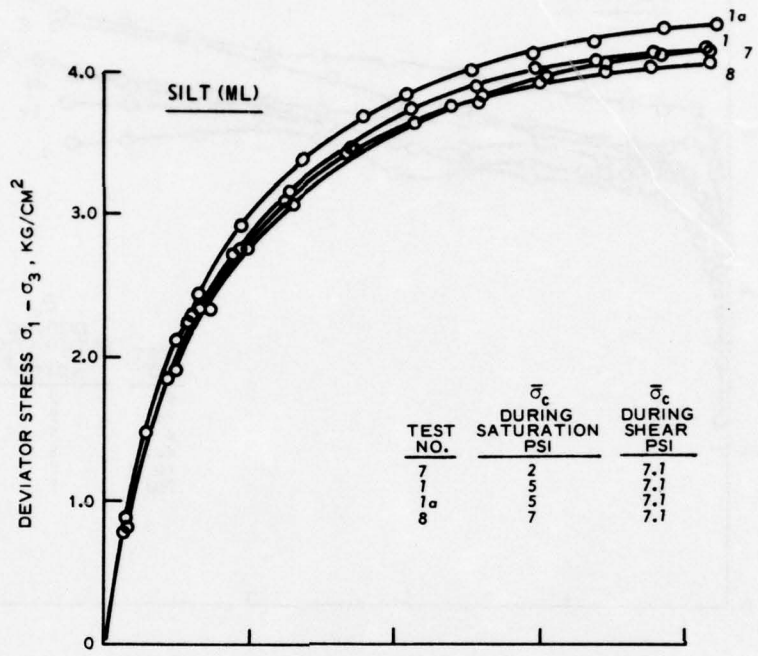

Figure 10. Deviator stress and induced pore pressure versus axial strain curves for tests in which the magnitude of the effective consolidation stress during saturation was varied, ML specimens

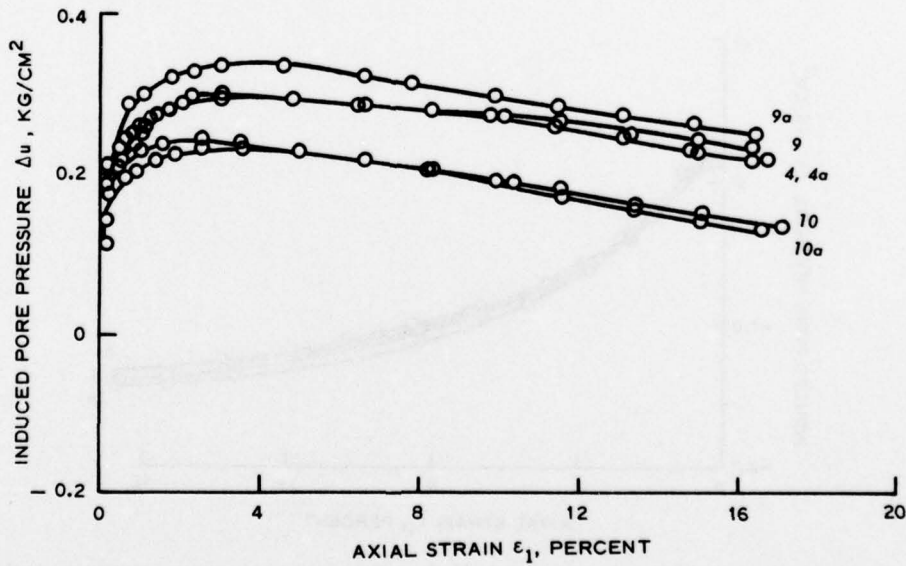
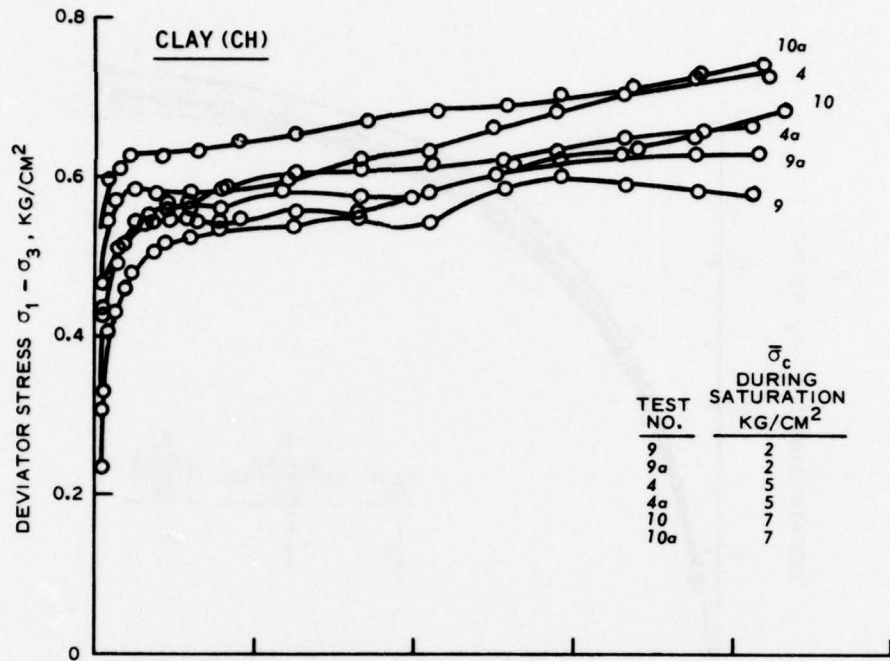

Figure 11. Deviator stress and induced pore pressure versus axial strain curves for tests in which the magnitude of the effective consolidation stress during saturation was varied, CH specimens

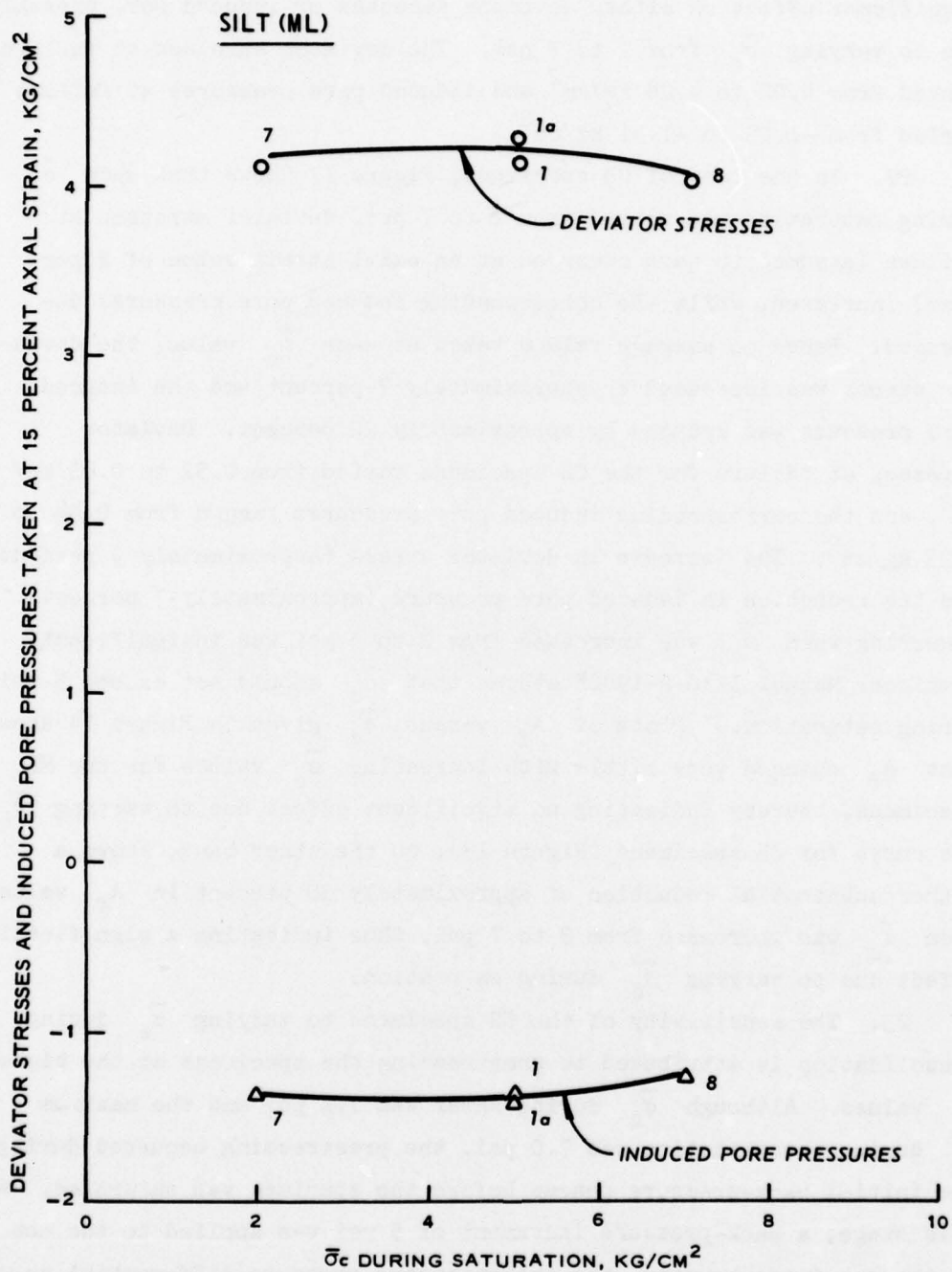

Figure 12. Deviator stresses and induced pore pressures taken at 15 percent axial strain versus the magnitude of the effective consolidation stress during saturation, ML specimens, $\bar{\sigma}_{3c} = 0.5 \text{ kg/cm}^2$ (7.1 psi)

significant effect on either deviator stresses or induced pore pressure due to varying $\bar{\sigma}_c$ from 2 to 7 psi. The deviator stresses at failure ranged from 4.02 to 4.28 kg/cm² and induced pore pressures at failure varied from -1.25 to -1.41 kg/cm².

22. In the case of CH specimens, Figure 13 shows that when $\bar{\sigma}_c$ during saturation was varied from 2 to 7 psi, deviator stresses at failure (assumed to have occurred at an axial strain value of 2 percent) increased, while the corresponding induced pore pressures decreased. Based on average values taken at each $\bar{\sigma}_c$ value, the deviator stress was increased by approximately 7 percent and the induced pore pressure was reduced by approximately 22 percent. Deviator stresses at failure for the CH specimens varied from 0.52 to 0.63 kg/cm², and the corresponding induced pore pressures ranged from 0.34 to 0.23 kg/cm². The increase in deviator stress (approximately 9 percent) and the reduction in induced pore pressure (approximately 7 percent) occurring when $\bar{\sigma}_c$ was increased from 2 to 5 psi was insignificant. (Engineer Manual 1110-2-1906* states that $\bar{\sigma}_c$ should not exceed 5 psi during saturation.) Plots of A_f versus $\bar{\sigma}_c$ given in Figure 14 show that A_f changed very little with increasing $\bar{\sigma}_c$ values for the ML specimens, thereby indicating no significant effect due to varying $\bar{\sigma}_c$. The curve for CH specimens (Figure 13), on the other hand, shows a rather substantial reduction of approximately 30 percent in A_f values when $\bar{\sigma}_c$ was increased from 2 to 7 psi, thus indicating a significant effect due to varying $\bar{\sigma}_c$ during saturation.

23. The sensitivity of the CH specimens to varying $\bar{\sigma}_c$ during consolidation is attributed to prestressing the specimens at the higher $\bar{\sigma}_c$ values. Although $\bar{\sigma}_c$ during shear was 7.1 psi and the maximum $\bar{\sigma}_c$ during consolidation was 7.0 psi, the prestressing occurred during the initial back-pressure phases before the specimen was saturated. At this stage, a back-pressure increment of 5 psi was applied to the top of the specimen; however, the instantaneous pressure differential across the specimen would be 5 psi, causing the instantaneous $\bar{\sigma}_c$ to be 12 psi

* Engineer Manual 1110-2-1906, op. cit.

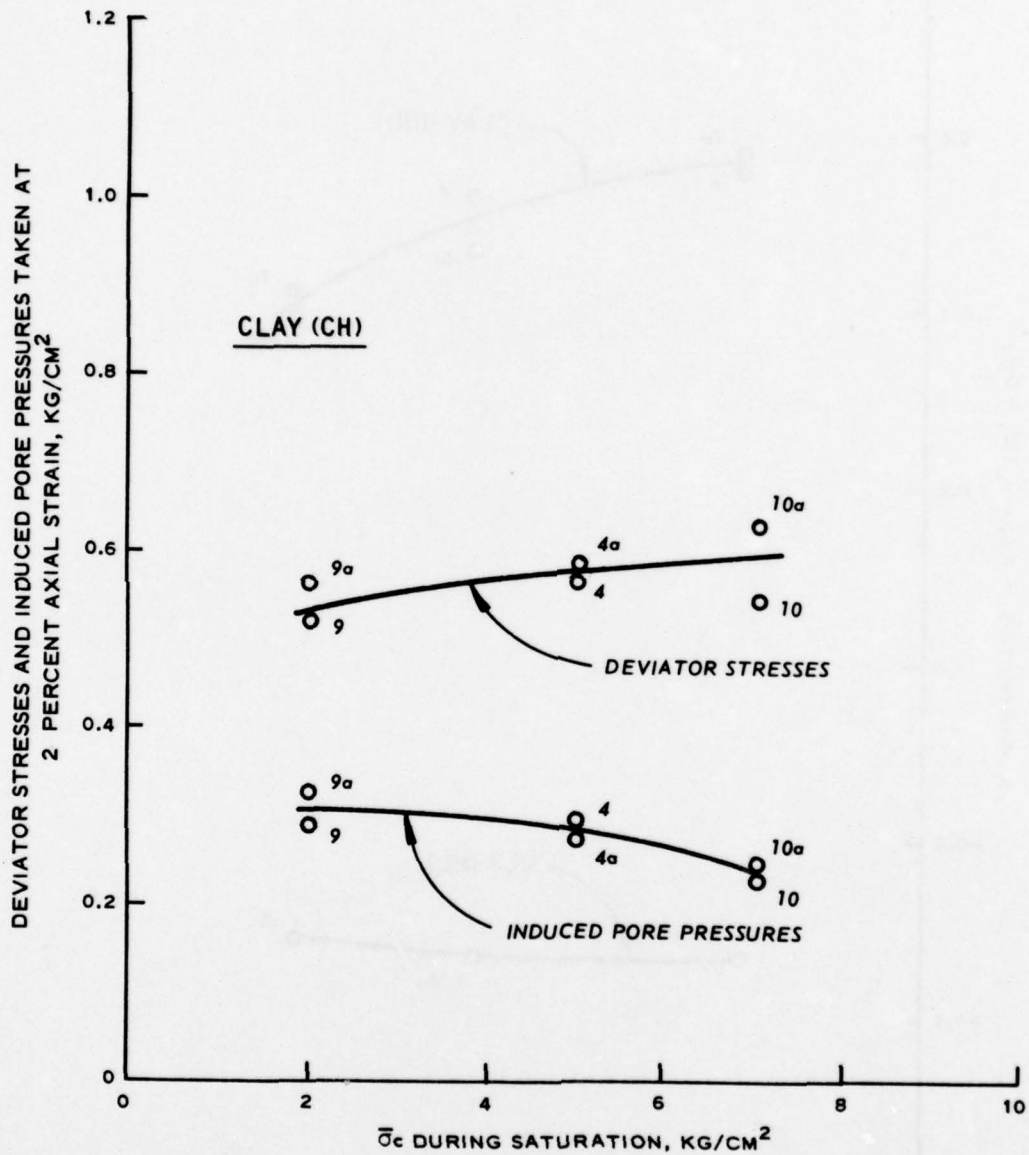

Figure 13. Deviator stresses and induced pore pressures taken at 2 percent axial strain versus the magnitude of the effective consolidation stress during saturation, CH specimens

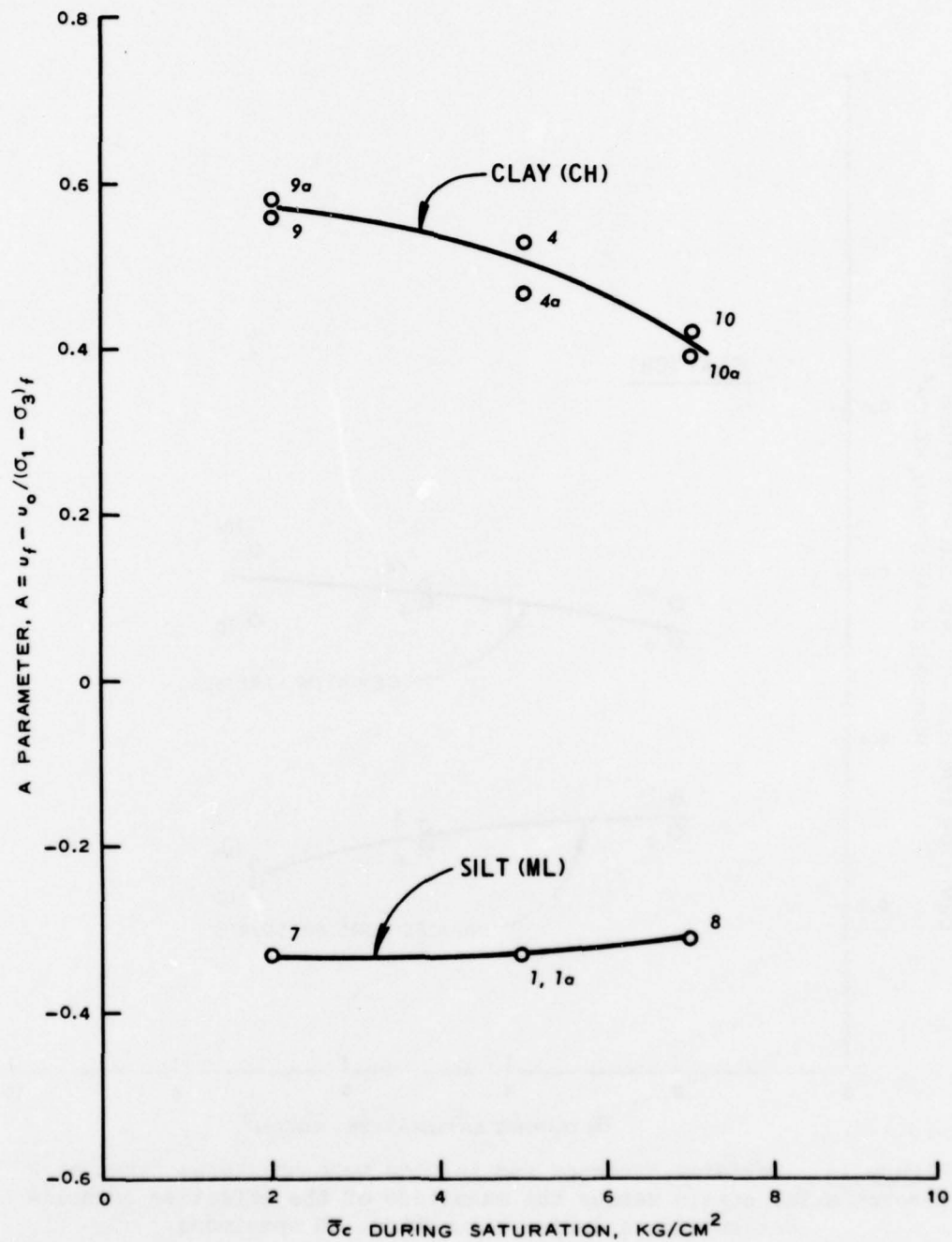

Figure 14. A parameters for CH and ML specimens taken at 2 and 15 percent axial strain, respectively, versus the magnitude of the effective consolidation stress during saturation

(7 + 5 psi). By this approach, the intermediate $\bar{\sigma}_c$ value of 5 psi would also lead to overstressing. The more permeable nature of the ML specimens probably minimized the instantaneous pressure differential and corresponding prestressing effect.

24. The following tabulation of A_f and $(\sigma_1 - \sigma_3)_f$ values for all tests on compacted CH specimens shows that effects due to varying $\bar{\sigma}_c$ from 2 to 7 psi were slightly greater than varying induced effective stresses due to back-pressure increments from 5 to 20 psi:

Test No.	Magnitude of Induced Effective Stress psi	Effective Consolidation Pressure $\bar{\sigma}_c$, psi	A Parameter at Failure A_f	Deviator Stress at Failure $(\sigma_1 - \sigma_3)_f$ kg/cm ²
----------	--	--	---------------------------------	---

Testing Variable - Magnitude of Induced Effective Stress

4	5	5	0.53	0.56
4a	5	5	0.48	0.58
5	10	5	0.51	0.53
5a	10	5	0.46	0.54
6	20	5	0.41	0.59
6a	20	5	0.43	0.63

Testing Variable - Magnitude of Effective Consolidation Stress

9	5	2	0.56	0.52
9a	5	2	0.59	0.56
4	5	5	0.54	0.56
4a	5	5	0.48	0.58
10	5	7	0.41	0.54
10a	5	7	0.38	0.63

As may be seen, A_f values for tests in which $\bar{\sigma}_c$ was varied ranged from 0.38 to 0.59, while those for tests in which induced effective stresses were varied, ranged from 0.41 to 0.53. It is of interest to note that the maximum change in $(\sigma_1 - \sigma_3)_f$ occurring for both testing variables was 0.11 kg/cm². Thus, the effect of both variables on $(\sigma_1 - \sigma_3)_F$ was to produce a maximum change in $(\sigma_1 - \sigma_3)_f$ of approximately 18 percent. The greater effect of varying $\bar{\sigma}_c$ on A_f values

rather than varying induced effective stresses is attributed to the fact that in varying $\bar{\sigma}_c$ the magnitude of $\bar{\sigma}_c$ is consistently applied to the specimen for longer times and at higher actual chamber pressures. Conversely, in varying the induced effective stress, only during the initial saturation stages is the maximum magnitude of induced effective stress applied to the specimen. However, as the specimen becomes saturated, the magnitude of induced effective stress decreases, hence the maximum value of induced effective stress is applied to the specimen for a shorter time period and at lower chamber pressures than when varying $\bar{\sigma}_c$.

Effect of Magnitude of Total Back Pressure

25. A differential vacuum saturation procedure was developed to determine the effect of the magnitude of total back pressures ranging as low as 10 psi in tests performed on ML specimens. The procedure, developed to avoid significant prestressing of the specimen, consists of initially de-airing the specimen by simultaneously increasing the vacuum acting on the top of the specimen and in the chamber, maintaining a small difference between them until a full vacuum is applied to the specimen. De-aired water is then allowed to flow through the specimen from bottom to top under a low differential vacuum head (approximately 5 psi), thus filling the previously de-aired voids with water. The vacuums applied to the top of the specimen and to the chamber are then slowly released, maintaining their initial difference until no vacuum is acting within the chamber and a vacuum equal to the initial difference is acting on the top of the specimen. This vacuum is then dissipated, maintaining the initial differential constant by simultaneously decreasing the vacuum and increasing the chamber pressure. The standard back-pressure saturation procedure is then initiated. During the procedure, the differential vacuum acting between the top and bottom of the specimen and the top of the specimen and the chamber is monitored with differential pressure transducers, which permits careful monitoring to avoid prestressing. Use of the differential vacuum saturation

procedure can saturate specimens with no significant effects due to prestressing and also has the advantage of enabling specimens to be saturated using back pressures equal to field hydrostatic conditions. The latter advantage would, of course, eliminate the problem of high laboratory strengths resulting from the greater negative induced pore pressures in dilative specimens during shear associated with the high back pressures usually required for saturation, since the expected field hydrostatic condition could be used as the back pressure. An additional advantage of the vacuum saturation procedure as applied to cohesionless soils is that the time for saturation is shorter, since it is not necessary to wait for significant amounts of air to pass into solution in the pore water under increasing back pressures. Time of saturation for the two tests in which the differential vacuum procedure was used (those having total back pressures of 10 and 60 psi) was less than 2 hr. The differential vacuum saturation procedure is outlined in Appendix C.

26. Figure 15 shows induced pore pressure and deviator stress versus axial strain curves for the tests performed on ML specimens in which the total back pressure was varied. As may be seen, both the deviator stress and induced pore-pressure curves indicate little effect due to varying the magnitude of total back pressure. Deviator stresses and induced pore pressures taken at 15 percent axial strain and plotted against total back pressure shown in Figure 16 indicate that there may be a slight trend for deviator stresses to increase and for induced pore pressures to decrease with increasing back pressures; however, the changes in both cases are insignificant (less than 9 percent). The A parameter versus total back pressure plot shown in Figure 17 also indicates no significant change in A due to varying the total back pressure, the average value of A being 0.33. It should be emphasized that the finding that varying the total magnitude of back pressure had little effect on induced pore pressures or strength should not be applied to other soils or to specimens of the standard ML material tested at higher dry unit weights or under lower consolidation pressures. Negative induced pore pressures and, hence, deviator stresses did not vary

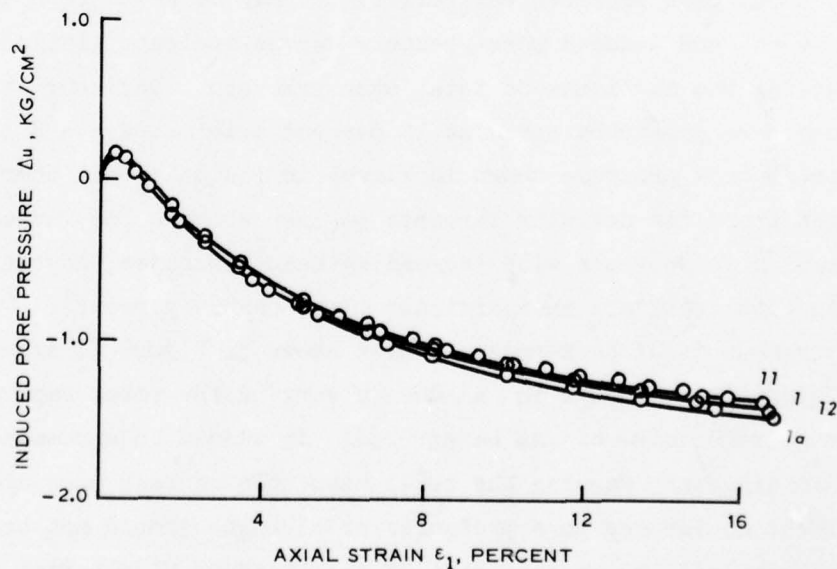
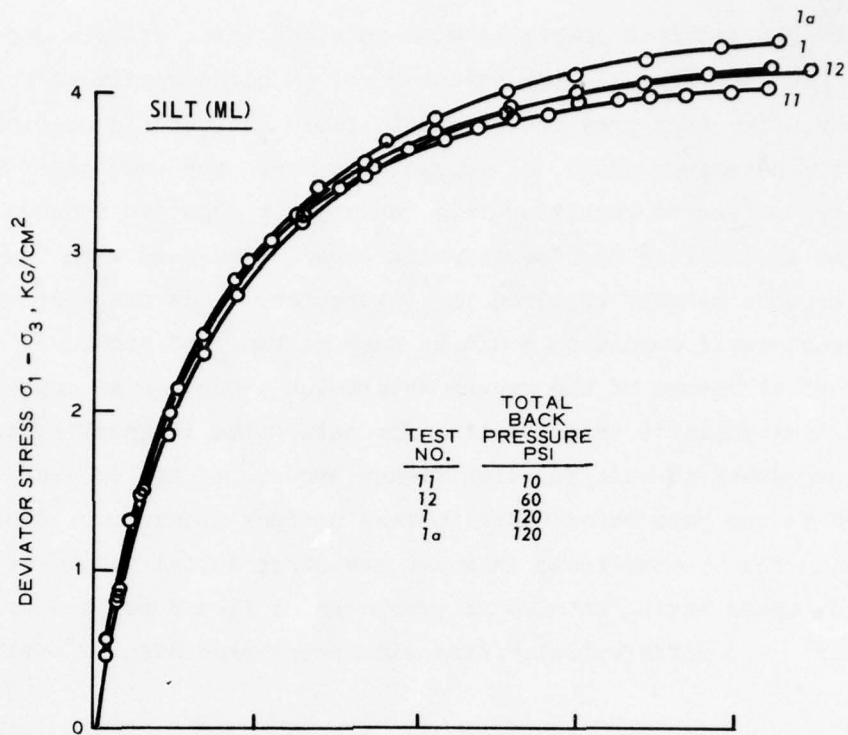

Figure 15. Deviator stress and induced pore pressure versus axial strain curves for tests in which the magnitude of the total back pressure was varied, ML specimens, $\bar{\sigma}_{3c} = 0.5 \text{ kg/cm}^2$

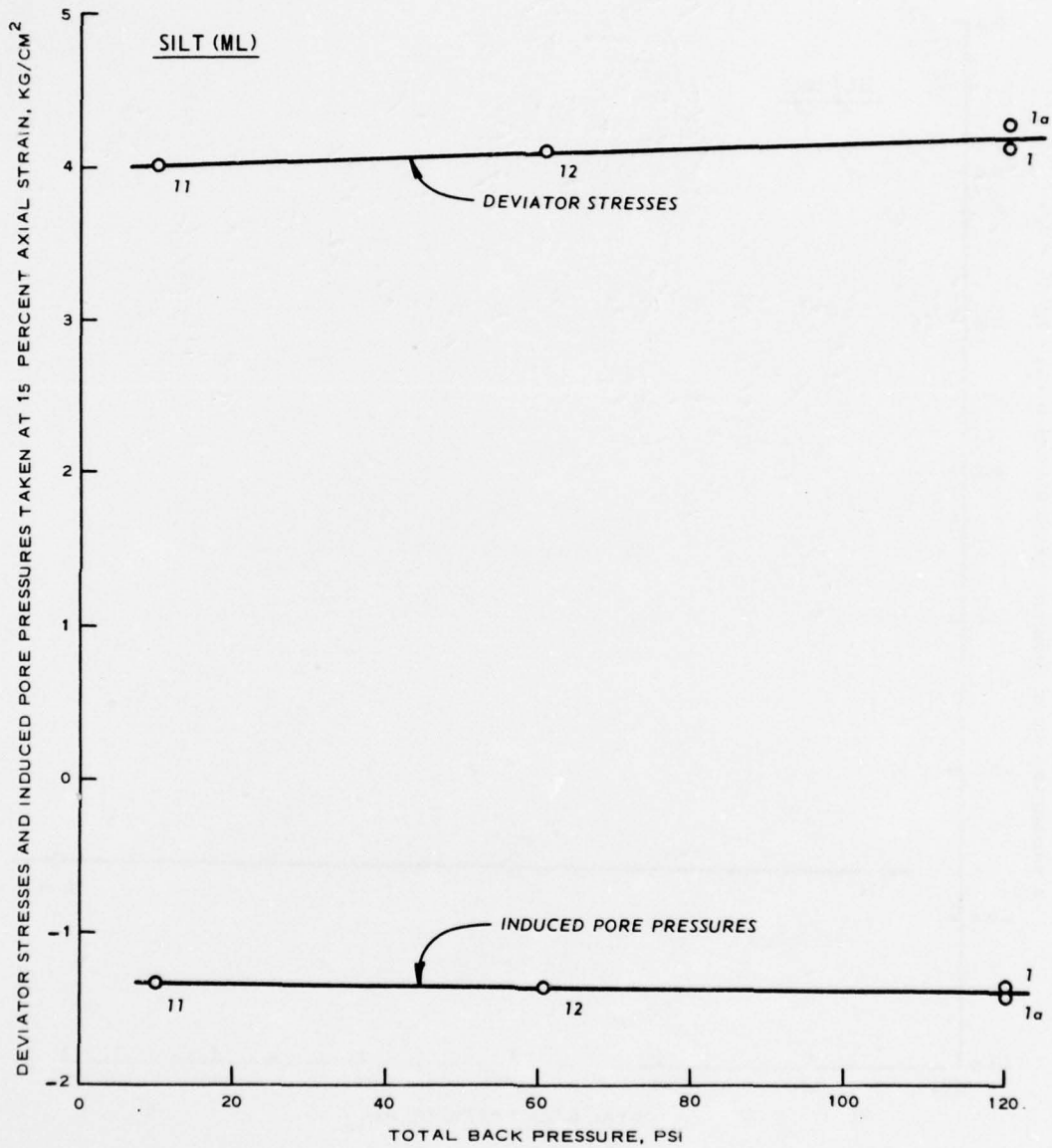

Figure 16. Deviator stresses and induced pore pressures taken at 15 percent axial strain versus total back pressure, ML specimens, $\bar{\sigma}_{3c} = 0.5 \text{ kg/cm}^2$ (7.1 psi)

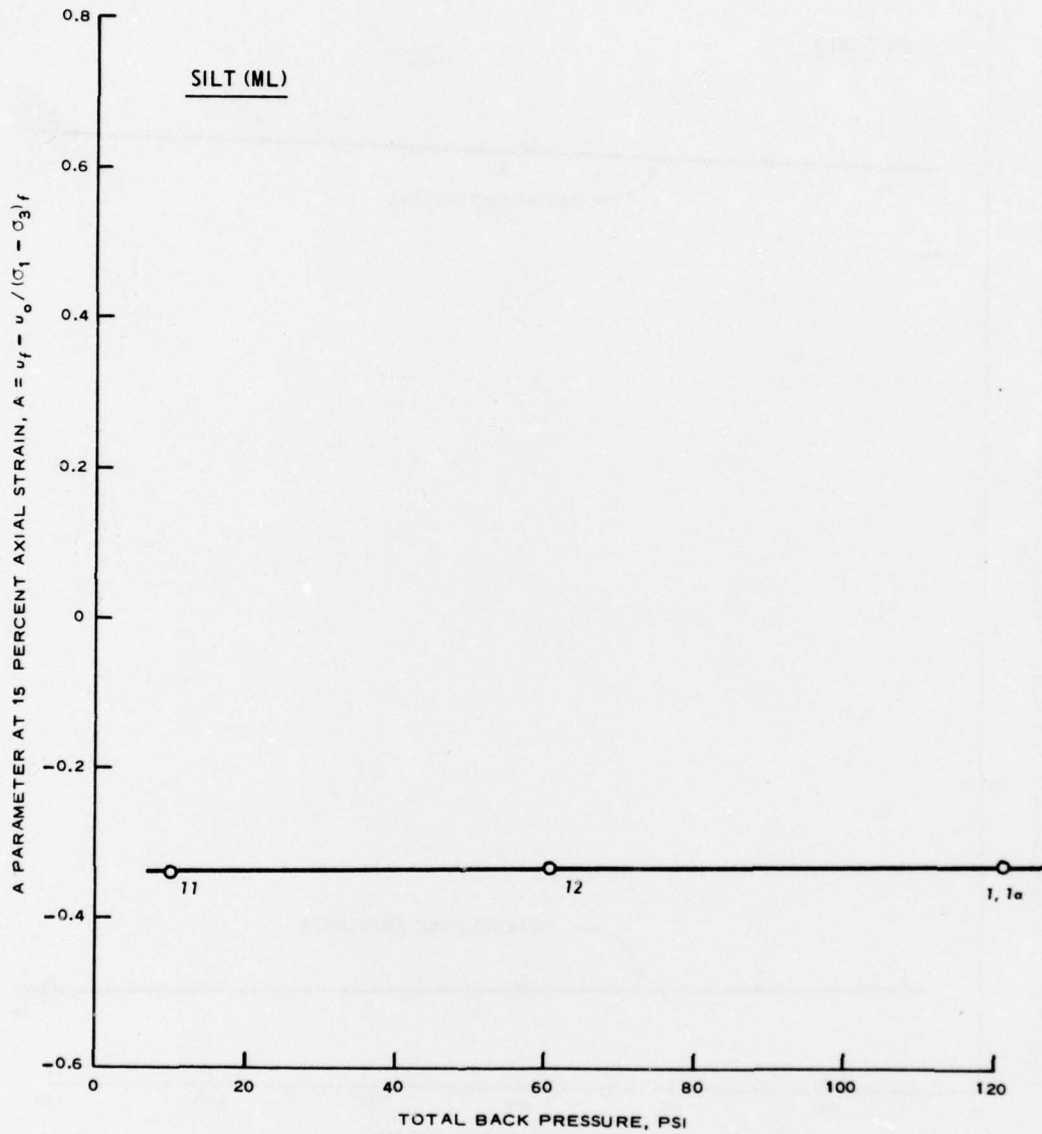

Figure 17. A parameter at 15 percent axial strain versus total back pressure, ML specimens, $\bar{\sigma}_c = 0.5 \text{ kg/cm}^2$ (7.1 psi)

with the total back pressure magnitude in the case of these tests only because the total back pressure was sufficient in each case to maintain complete saturation during shear; i.e., for the range of total back pressures used, negative pore pressures were not great enough to allow air to come out of solution or cavitation of the pore water.

CH Material Consolidated from a Slurry

27. Deviator stress and induced pore pressure versus axial strain curves for the CH specimens consolidated from a slurry and sheared under different total back-pressure magnitudes are given in Figures 18 and 19. Deviator stresses and induced pore pressures at failure (at 2 percent axial strain) for the $\bar{\sigma}_c = 0.5 \text{ kg/cm}^2$ tests ranged from 1.35 to 1.39 kg/cm^2 and from 0.01 to 0.06 kg/cm^2 , respectively, while those for the $\bar{\sigma}_c = 4.0 \text{ kg/cm}^2$ tests varied from 2.66 to 2.74 kg/cm^2 and from 2.30 to 2.45 kg/cm^2 , respectively. In both cases, the maximum change in deviator stress and induced pore pressure at failure was less than 10 percent, thus indicating no significant effect due to varying the total back pressure in the overconsolidated ($\bar{\sigma}_c = 0.5 \text{ kg/cm}^2$) or normally consolidated ($\bar{\sigma}_c = 4.0 \text{ kg/cm}^2$) ranges.

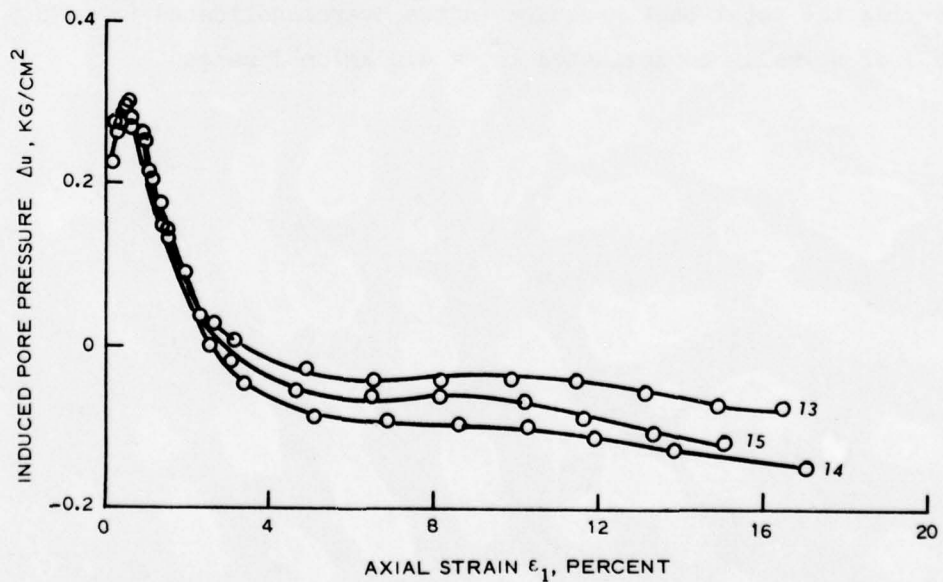
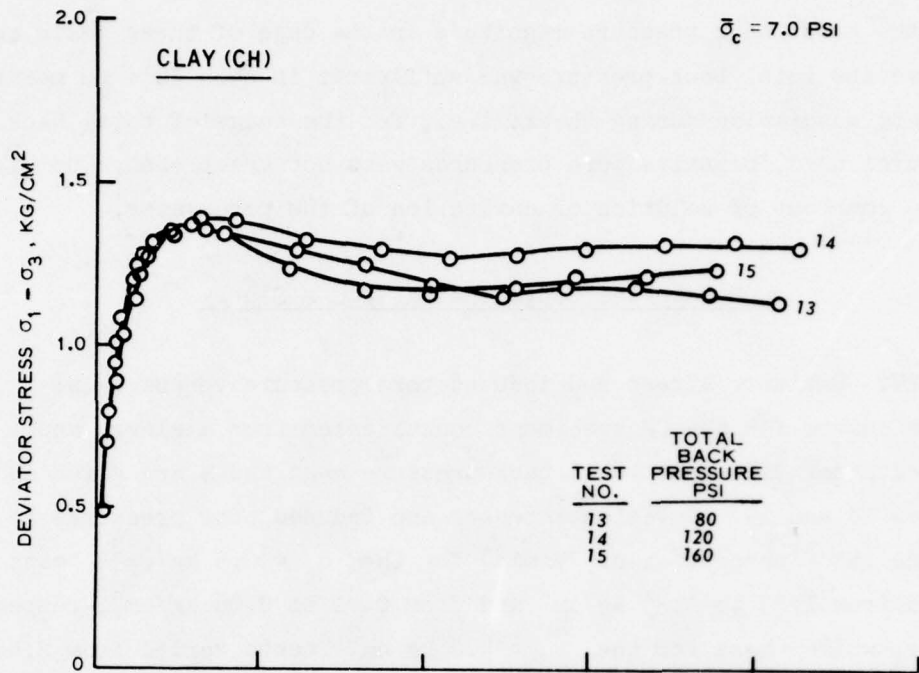

Figure 18. Deviator stress and induced pore pressure versus axial strain curves for tests 13, 14, and 15 in which the magnitude of the total back pressure was varied, CH specimens consolidated from a slurry

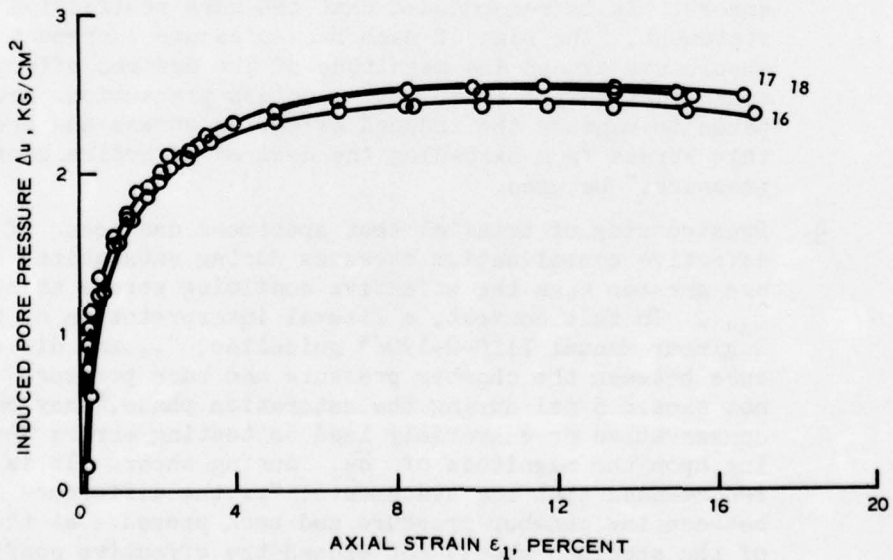
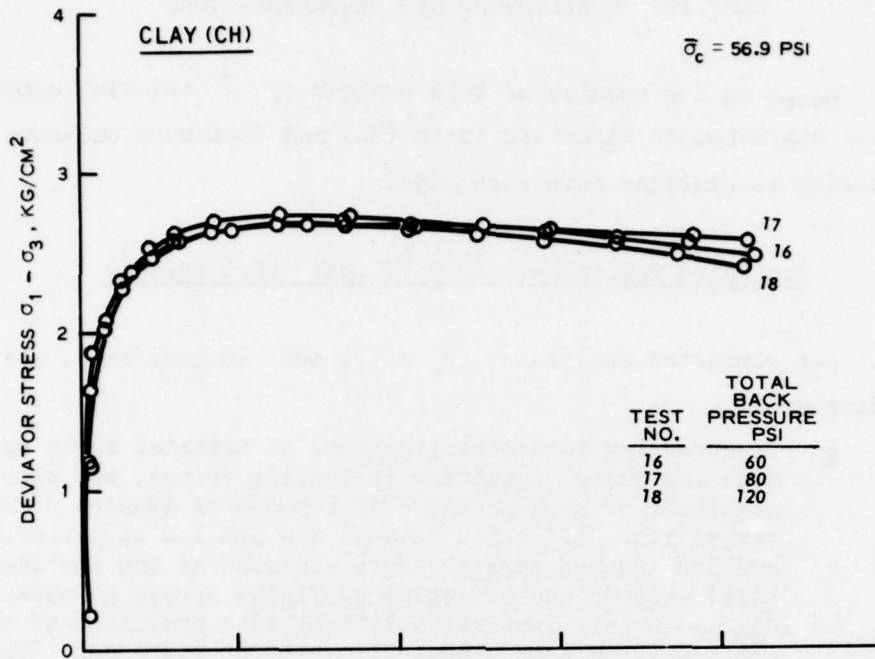

Figure 19. Deviator stress and induced pore pressure versus axial strain curves for tests 16, 17, and 18 in which the magnitude of the total back pressure was varied, CH specimens consolidated from a slurry

PART IV: CONCLUSIONS AND RECOMMENDATIONS

28. Based on the results of this program of \bar{R} triaxial compression tests conducted on Vicksburg loess (ML) and Vicksburg buckshot (CH), the following conclusions have been made.

Compacted Specimens, $\bar{\sigma}_c = 7.1 \text{ psi (0.5 kg/cm}^2\text{)}$

29. For compacted specimens, $\bar{\sigma}_c = 7.1 \text{ psi (0.5 kg/cm}^2\text{)}$, the conclusions are:

- a. Prestressing (overconsolidation) of triaxial tests specimens can occur, resulting in testing errors, any time the magnitude of back-pressure increments or induced effective stress (the difference between the applied back pressure and the induced pore pressure measured at the specimen base) exceeds the effective confining stress at shear, $\bar{\sigma}_{3c}$. In this context, a literal interpretation of the arbitrary Engineer Manual 1110-2-1906* statement, "The size of each increment (of back pressure) might be 5, 10, or even 20 psi, depending on the compressibility of the soil specimen and magnitude of the desired consolidation pressure," can lead to prestressing and associated errors. It is recommended that the more restrictive statement, "the size of each back-pressure increment should not exceed the magnitude of the desired effective consolidation pressure, $\bar{\sigma}_{3c}$, unless precautions are taken to monitor the induced effective stress and prevent this stress from exceeding the desired effective confining pressure," be used.
- b. Prestressing of triaxial test specimens can occur if $\bar{\sigma}_c$ are greater than the effective confining stress at shear, $\bar{\sigma}_{3c}$. In this context, a literal interpretation of the Engineer Manual 1110-2-1906* guideline, "...the difference between the chamber pressure and back pressure should not exceed 5 psi during the saturation phase," may be too conservative or conversely lead to testing errors depending upon the magnitude of $\bar{\sigma}_{3c}$ during shear. It is recommended that the statements, "...the difference between the chamber pressure and back pressure at the top of the specimen should not exceed the effective confining stress during shear, $\bar{\sigma}_{3c}$. It is suggested, but not

* Engineer Manual 1110-2-1906, op. cit.

required, that this difference not exceed 5 psi when $\bar{\sigma}_{3c}$ is greater than 5 psi," be substituted as this guideline.

- c. The magnitude of total back pressure had no significant effect on test results of ML specimens where induced negative pore pressures are less than 22 psi. However, Engineer Manual 1110-2-1906 provides no guidance concerning selection of peak strengths of dilative soils where negative induced pore pressures can create excessively high strengths.
- d. The effect of prestressing caused by the magnitude of the effective consolidation stress during saturation (conclusion b) can have a greater effect than the magnitude of induced effective stress (conclusion a) when both magnitudes are the same.

CH Specimens Consolidated from a Slurry, $\bar{\sigma}_c = 7.0$ and 56.9 psi
(0.5 and 4.0 kg/cm²)

30. There is no significant effect on deviator stresses or induced pore pressures taken at failure due to varying the total back pressure from 60 to 120 psi and from 80 to 160 psi on normally ($\bar{\sigma}_c = 4.0$ kg/cm²) and overconsolidated ($\bar{\sigma}_c = 0.5$ kg/cm²) CH specimens, respectively, consolidated from a slurry under a maximum effective vertical consolidation stress of 3.0 kg/cm².

Testing Equipment and Procedures

31. An automatic back-pressure saturation device has been designed and fabricated that duplicates the procedure outlined in the laboratory soils testing manual (see Appendix A). The device provides a satisfactory alternative means for back-pressure saturating specimens when used in the mode to control the magnitude of the induced effective stress during saturation.

32. A differential vacuum saturation procedure has been developed that enables specimens of cohesionless soils to be saturated using back pressures equal to field hydrostatic conditions.

33. An investigation into the effects of using the differential vacuum saturation procedure on dilative soils in which cavitation will occur under back pressures equal to field hydrostatic conditions is

needed. The purpose of this investigation should be to determine whether strength envelopes obtained from such tests could be used in design analyses. Also, further testing should be conducted to determine the effect of varying the total time for saturation, since thixotropic effects were not studied in this investigation.

Table 1
Saturation Phase of \bar{R} Triaxial Tests*

Specimen Characteristic, Apparatus, or Technique	Symbol or Abbreviation	Laboratory										
		1	2	3	4	5	6	7	8	9		
Largest back-pressure increment, psi	Δu_o max	80.25	10.00	10.00	10.00	10.00	20.00	35.00	10.00	10.00	5.55	28.80
Smallest back-pressure increment, psi	Δu_o min	1.00	10.00	10.00	10.00	5.00	1.95	4.00	10.00	10.00	1.40	2.92
Smallest effective consolidation pressure during back pressur- ing, psi	$\Delta \bar{\sigma}_c$ min	5.00	4.04	1.00	1.95	1.95	1.95	1.95	1.95	1.95	2.80	2.92
Shortest duration of back- pressure increment, min	Δt_s min	120	1	3	10	60	120	2	2	30	2	2
Total time for saturation, min	t_s	2,880- 14,400	1,860- 6,180	270- 5,760	1,440	255- 1,680	8,450- 20,000	21- 1,950	300- 1,440	420- 1,440		

* Data taken from Miscellaneous Paper 3-813, op. cit. Data represent range in differences for all tests performed on the three soil types (ML, CL, and CH).

Table 2
 Part 1 of Testing Program, Effects of Back-Pressure Saturation
 Techniques in R Triaxial Tests on Compacted Soils

To Study Effect of:	Test No.	Back-Pressure Increments psi	Maximum Induced Effective Stress* psi	$\bar{\sigma}_c$ During Saturation psi	Total Back Pressure psi
Magnitude of back-pressure increments	1**,†	5	--	5	120
	2**,†	10	--	5	
	3**,†	20	--	5	
Magnitude of induced effective stress	4†,††	--	5	5	160
	5†,††	--	10	5	
	6†,††	--	20	5	
Magnitude of $\bar{\sigma}_c$ during saturation	7**	5	--	2	120
	1**	5	--	5	
	8**	5	--	7	
Magnitude of total back pressure	9†,††	--	5	2	160
	4†,††	--	5	5	
	10†,††	--	5	7	
Magnitude of total back pressure	11**	--	5	5	10
	12**	--	5	5	60
	1**	--	5	5	120

* The difference between the back pressure applied at the top of the specimen and the induced pore pressure measured at the bottom of the specimen.

** Tests performed on ML specimens.

† Duplicate tests were performed.

†† Tests performed on CH specimens.

Table 3

Part 2 of Testing Program, Effects of Magnitude of
Back Pressure in \bar{R} Triaxial Tests on Specimens
of Standard CH Soil Consolidated From a Slurry*

Test No.	Total Back Pressure psi	Maximum Induced Effective Stress** psi	Chamber Pressure Minus Back Pressure, $\bar{\sigma}_c$, During	
			Saturation psi	Consolidation psi
<u>First Series</u>				
13	80	5	5	7
14	120	5	5	7
15	160	5	5	7
<u>Second Series</u>				
16	60	5	5	56.9
17	80	5	5	56.9
18	120	5	5	56.9

* Slurried sample from which specimens were trimmed was consolidated under a total vertical consolidation stress of 3.0 kg/cm² (42.7 psi).

** The difference between the back pressure applied at the top of the specimen and the induced pore pressure measured at the bottom of the specimen.

Table 4
Summary of $\bar{\sigma}$ Triaxial Compression Test Data*

Effect Investigated	Material	Test No.**	Initial Specimen Conditions			Magnitude of Back-Pressure Increments	During Back-Pressure Saturation		Total Back Pressure	After Back-Pressure Consolidation		Axial Loading Data at Failure†						
			Water Content %	Void Ratio	Saturation Degree		Dry Unit Weightpcf	Back Pressure psi		Maximum Induced Stress psi	Water Content %	Parameter, $B = \Delta u / \Delta \sigma_3$	$\bar{\sigma}_1 - \bar{\sigma}_3$ kg/cm ²	$\bar{\sigma}_1 - \bar{\sigma}_3$ kg/cm ²	$u - u_0$ kg/cm ²	$\bar{\sigma}_3$ kg/cm ²	Parameter A = $u - u_0 / \bar{\sigma}_1 - \bar{\sigma}_3$	Strain
Magnitude of back-pressure increments	Silt (ML)	1††	14.5	0.682	57.8	101.0	5	---	120	25.1	1.00	0.5	4.12	-1.34	-1.84	3.81	-0.33	15
		2††	14.6	0.683	57.9	100.9	5	---	120	25.1	0.98	0.5	4.28	-1.41	-1.91	3.77	-0.33	15
		3††	14.8	0.683	58.8	100.9	10	---	120	25.1	0.98	0.5	4.05	-1.30	-1.80	3.87	-0.32	15
		4††	14.5	0.679	58.1	101.1	10	---	120	25.0	0.99	0.5	4.27	-1.33	-1.83	3.96	-0.31	15
		5††	14.7	0.681	58.6	101.0	20	---	120	25.0	0.98	0.5	4.49	-1.54	-2.04	3.72	-0.34	15
		6††	14.4	0.678	57.9	101.2	20	---	120	24.9	1.00	0.5	4.86	-1.71	-2.21	3.73	-0.35	15
Magnitude of induced effective stress	Clay (CH)	4††	24.4	0.803	81.6	93.1	5	---	160	30.2	0.99	0.5	0.56	0.30	0.20	4.10	0.53	2
		5††	24.2	0.796	81.8	93.4	5	---	160	30.4	0.98	0.5	0.58	0.28	0.22	4.03	0.47	2
		6††	24.4	0.788	83.4	93.9	10	---	160	30.0	0.98	0.5	0.53	0.27	0.23	3.48	0.52	2
		7††	24.5	0.797	82.6	94.0	10	---	160	30.2	1.00	0.5	0.54	0.25	0.25	3.41	0.47	2
		8††	24.5	0.793	83.0	93.6	20	---	160	30.0	0.96	0.5	0.59	0.24	0.26	3.50	0.41	2
		9††	24.1	0.812	79.9	92.6	20	---	160	30.0	0.95	0.5	0.63	0.27	0.23	4.27	0.42	2
Magnitude of $\bar{\sigma}_3$ during saturation	Silt (ML)	1††	14.5	0.678	58.0	101.2	5	---	120	25.1	1.00	0.5	4.10	-1.36	-1.86	3.76	-0.33	15
		2††	14.5	0.682	57.8	101.0	5	---	120	25.1	1.00	0.5	4.12	-1.34	-1.84	3.81	-0.33	15
		3††	14.6	0.683	57.9	100.9	5	---	120	25.1	0.98	0.5	4.28	-1.41	-1.91	3.77	-0.33	15
		4††	14.5	0.682	57.8	100.9	5	---	120	25.0	0.99	0.5	4.02	-1.25	-1.75	3.80	-0.31	15
		5††	24.0	0.798	80.9	93.4	5	---	160	31.0	1.00	0.5	0.52	0.29	0.21	3.76	0.56	2
		6††	24.4	0.803	81.6	93.1	5	---	160	30.2	0.99	0.5	0.56	0.33	0.17	4.82	0.58	2
Magnitude of total back pressure	Clay (CH)	1††	24.4	0.803	81.6	93.1	5	---	160	30.2	0.99	0.5	0.56	0.30	0.20	4.10	0.53	2
		2††	24.2	0.796	81.8	93.4	5	---	160	30.4	0.98	0.5	0.58	0.28	0.22	4.03	0.47	2
		3††	24.3	0.805	81.4	93.0	5	---	160	30.3	1.00	0.5	0.54	0.23	0.27	3.10	0.42	2
		4††	24.2	0.789	82.4	93.8	5	---	160	29.5	1.00	0.5	0.63	0.25	0.25	3.59	0.39	2
		5††	14.1	0.663	57.2	100.9	5	---	120	25.3	0.98	0.5	4.01	-1.33	-1.83	3.20	-0.33	15
		6††	13.9	0.662	56.5	101.0	5	---	120	25.1	0.99	0.5	4.09	-1.38	-1.88	3.19	-0.34	15
Clay (CH)	1††	14.5	0.682	57.8	101.0	5	---	120	25.1	1.00	0.5	4.12	-1.34	-1.84	3.81	-0.33	15	
	2††	14.6	0.683	57.9	100.9	5	---	120	25.1	0.98	0.5	4.28	-1.41	-1.91	3.77	-0.33	15	
	3††	30.6	0.819	100	92.9	5	---	80	31.9	1.00	0.5	1.35	0.06	0.43	1.14	0.04	2.3	
	4††	30.2	0.824	98.5	92.0	5	---	120	31.3	0.99	0.5	1.29	0.01	0.48	3.20	0.01	2.6	
	5††	30.2	0.837	100	91.4	5	---	160	31.5	1.00	0.5	1.37	0.01	0.48	3.85	0.01	2.4	
	6††	27.6	0.751	98.6	95.9	5	---	60	26.8	0.99	4.0	2.74	2.30	1.70	2.61	0.84	4.9	
Clay (CH)	17††	30.3	0.832	97.8	91.8	5	---	80	27.1	0.99	4.0	2.69	2.45	1.55	2.74	0.91	5.8	
	18††	30.2	0.824	98.6	92.0	5	---	120	27.0	1.00	4.0	2.66	2.45	1.55	2.72	0.92	5.8	

* Symbols used in the headings are defined in Engineer Manual 1110-2-1906.

** Test numbers with subscripts are duplicate tests.

†† Failures assumed to be occurred on compacted specimens.

‡‡ CH specimens (c) ($\sigma_1 - \sigma_3$) and for tests performed on CH specimens consolidated from a slurry.

§§ Tests performed on compacted specimens.

¶¶ Tests performed on specimens consolidated from a slurry under a maximum vertical consolidation stress of 3.0 kg/cm².

APPENDIX A: BACK-PRESSURE SATURATION PROCEDURE
 SPECIFIED IN ENGINEER MANUAL 1110-2-1906

1. The back-pressure saturation procedure shall consist of the following steps:

- a. Step 1. Estimate the magnitude of the required back pressure by reference to Figure A1 or other theoretical

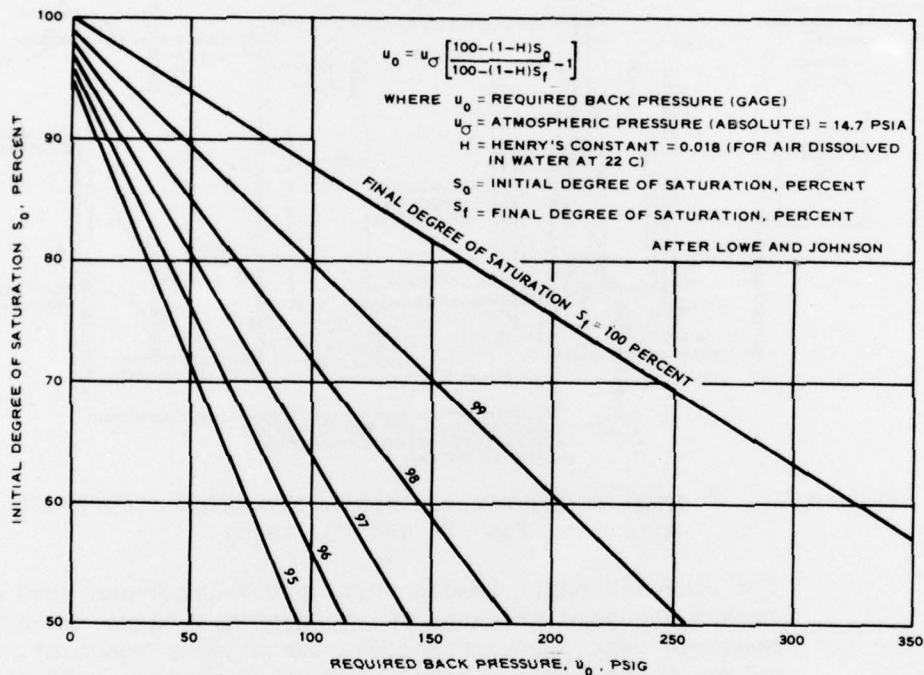

Figure A1. Back pressure required to attain various degrees of saturation

relations. Specimens should be completely saturated before any appreciable consolidation is permitted, for ease and uniformity of saturation as well as to allow volume changes during consolidation to be measured with the burette; therefore, the difference between the chamber pressure and the back pressure should not exceed 5 psi during the saturation phase. To insure that a specimen is not prestressed during the saturation phase, the back pressure must be applied in small increments, with adequate time between increments to permit equalization of pore-water pressure throughout the specimen.

- b. Step 2. With all valves closed, adjust the pressure regulators to a chamber pressure of about 7 psi and a

back pressure of about 2 psi. Record these pressures on the data sheet. Now open valve A to apply the preset pressure to the chamber fluid and simultaneously open valve F (Figure A2) to apply the back pressure through

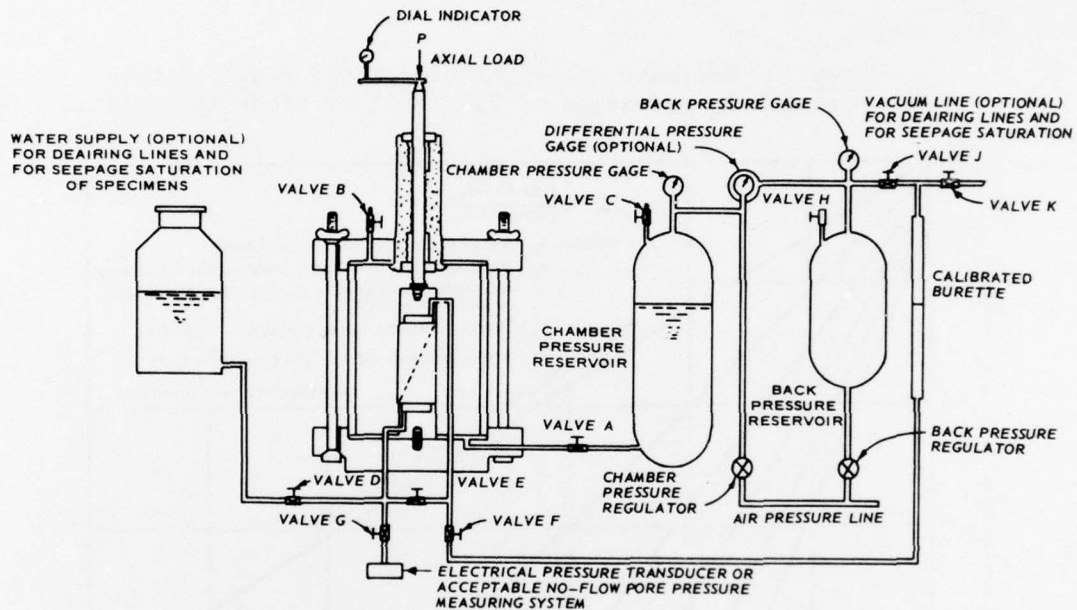

Figure A2. Schematic diagram of typical triaxial compression apparatus for R and S tests

the specimen cap. Immediately open valve G and read and record the pore pressure at the specimen base. When the measured pore pressure becomes essentially constant, close valves F and G and record the burette reading. If an electrical pressure transducer is used to measure the pore pressure, valve G may be safely left open during the entire saturation procedure.

- c. Step 3. Using the technique described in step 2, increase the chamber pressure and the back pressure in increments, maintaining the back pressure at about 5 psi less than the chamber pressure. The size of each increment might be 5, 10, or even 20 psi, depending on the compressibility of the soil specimen and the magnitude of the desired consolidation pressure. Open valve G and measure the pore pressure at the base immediately upon application of each increment of back pressure and observe the pore pressure until it becomes essentially constant. The time required for stabilization of the pore pressure may range from a few minutes to several hours, depending on the permeability of the soil. Continue adding increments of chamber

pressure and back pressure until, under any increment, the pore-pressure reading equals the applied back pressure immediately upon opening valve G.

- d. Step 4. Verify the completeness of saturation by closing valve F and increasing the chamber pressure by about 5 psi. The specimen shall not be considered completely saturated unless the increase in pore pressure immediately equals the increase in chamber pressure.

APPENDIX B: OPERATION OF AUTOMATIC BACK-PRESSURE SATURATION
APPARATUS AND PRESSURE CONTROL SYSTEM

1. The following procedures for saturating specimens are referenced to Figure B1.

Controlled Magnitude of Effective Stress
Induced by Back-Pressure Procedure

2. Follow these steps:

- a. De-air the portion of the system containing differential pressure transducer No. 1 by applying a vacuum through valve I. Valves B, C, and E should be open and valves A, D, F, and J should be closed. Burette No. 1 should contain sufficient de-aired water to replace air removed from the system during this process.
- b. Flush the lines to the specimen cap and base with de-aired water. Valves B, C, F, and either valve A or D should be open to burette No. 2, which should contain sufficient de-aired water to accomplish the operation. (Valve D should be opened to de-air the line to the specimen cap. Valve A should be opened to de-air the line to the specimen base.) Valve E should be closed and valves I and J should be open.
- c. Close valves A and D and refill burette No. 2 with sufficient de-aired water to saturate the specimen and then adjust differential pressure transducer No. 1 to read zero using the proper control on the pacer console.
- d. Set the upper and lower limits for the differential pressure between the top and bottom of the specimen (the induced effective stress) to be used during automatic saturation by adjusting the appropriate controls on the pacer console. The lower limiting differential pressure should be higher than any possible pressure difference due to the head loss occurring as the water level in the burette falls.
- e. After placing the specimen in the chamber, close the throttle valve and adjust the back-pressure regulator to the maximum desired back pressure to be applied during the saturation procedure. The pressure may be read on the back-pressure gage.
- f. Apply the desired difference between the chamber and back pressure, σ_c , to the specimen using the spring control on the spring- and/or air-controlled pressure regulator. The pressure may be read on the differential pressure gage. Open valve G after the pressure has been set.

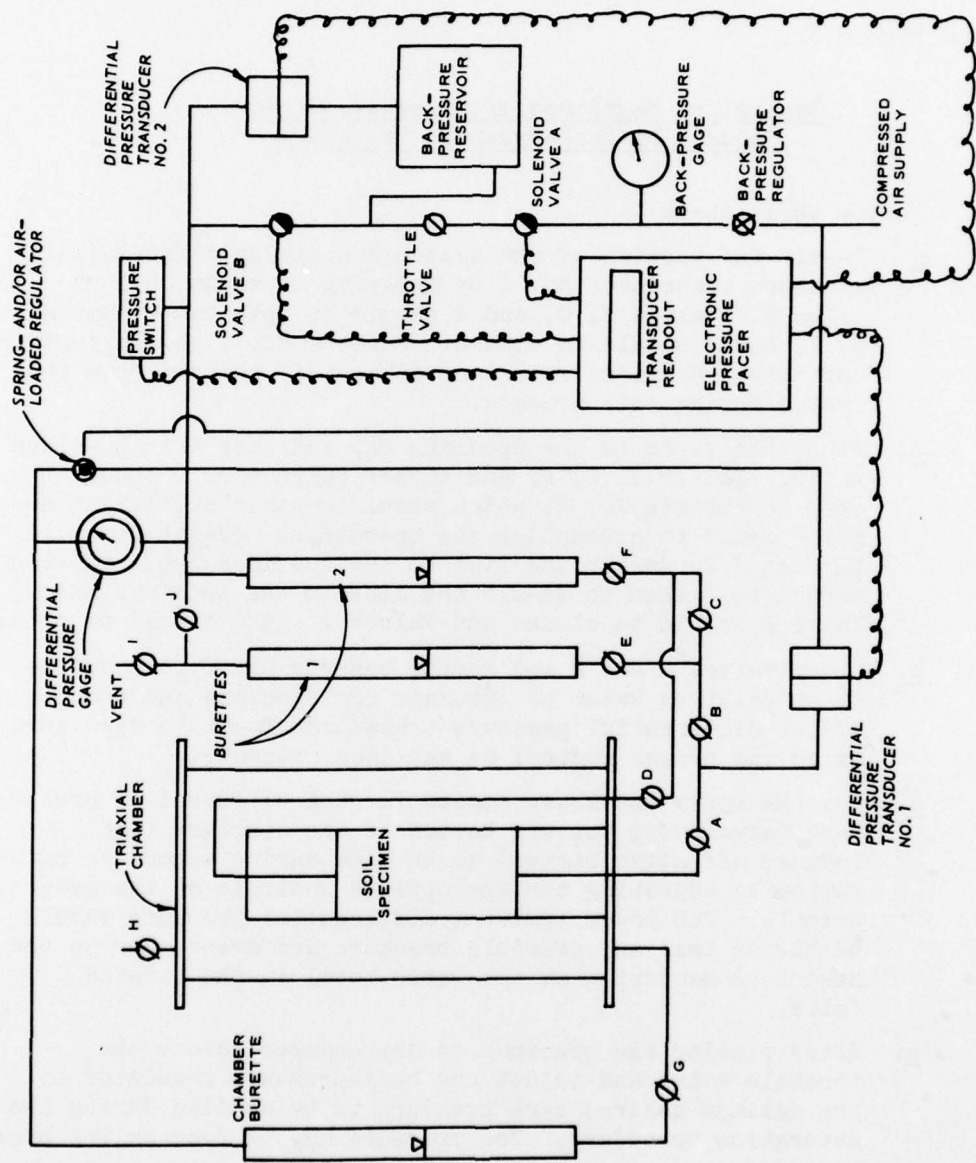

Figure B1. Schematic diagram of the back pressure saturation apparatus and pressure control

- g. Close valves B, C, and J and open valves A and D. Automatic saturation may now be initiated by switching the "start" control on the pressure pacer for the controlled magnitude of induced effective stress procedure and by opening the throttle valve, thus allowing pressure applied by the back-pressure regulator access to the specimen (through burette No. 2), the spring- and/or air-loaded regulator, and differential pressure transducer No. 1. When the pressure transducer indicates the maximum desired induced stress has been developed, solenoid valve A closes (solenoid valve B remains open during this particular saturation procedure) and will not open again until the transducer indicates that the induced stress has been reduced to the desired lower limit, whereupon the process is repeated. This operation continues until the total desired back pressure has been applied to the specimen. The saturation procedure has been completed when the differential pressure reading for transducer No. 1 indicates that the induced effective stress is less than the preset lower limiting value used to open solenoid valve A to apply an additional increment of back pressure. (Solenoid valve A will be open at this stage and the total desired back pressure will be acting on the specimen.)
- h. When the differential pressure reading for transducer No. 1 indicates an equilibrium condition within the specimen under the total back pressure, a B value determination may be made by closing valves B and G, increasing the chamber pressure by 10 psi using the spring control on the spring- and/or air-loaded pressure regulator, and then opening valve G and observing the pore-pressure response using transducer No. 1. If the specimen is not saturated even though the desired back pressure has been applied, simply increase the back pressure using the back-pressure regulator and the saturation sequence will automatically resume. It may be necessary to increase the pressure several times before the B check indicates complete saturation.

Controlled Magnitude of Back-Pressure Increment Procedure

3. This procedure is identical to the preceding procedure except for steps d and g. Components of the apparatus not used in the preceding procedure but used for this mode of operation are differential pressure transducer No. 2, solenoid valve B, and the pressure switch (see Figure B1).

Step d

4. Set the desired magnitude for the back-pressure increments and the lower limiting value for the induced effective stress using the proper controls on the pacer console. Next, set the pressure switch so that it will provide a signal to open both solenoid valves when the total desired back pressure has been reached.

Step g

5. Close valves B, C, and J and open valves A and D. Automatic saturation may now be initiated by switching the "start" control on the pressure pacer console for the controlled magnitude of back-pressure increment procedure and opening the throttle valve. When the reading for pressure transducer No. 2 indicates the desired magnitude of the back-pressure increment, solenoid valve B opens and solenoid valve A closes, thus placing the pressure increment into the system acting on the specimen. When the lower limiting induced effective stress is sensed by transducer No. 1, solenoid valve A opens and solenoid valve B closes, thus initiating another cycle of the procedure. This operation continues until the pressure switch senses that the total desired back pressure is acting on the specimen, whereupon both solenoid valves are switched to their open positions.

APPENDIX C: DIFFERENTIAL VACUUM SATURATION PROCEDURE

1. The following procedure is referenced to Figure C1.
 - a. De-air the system containing the differential pressure transducer by applying a vacuum through valve J, using regulator No. 2. Valves B and E should be open and valves C and I should be closed. Burette No. 1 should contain sufficient de-aired water to replace air removed from the system during this operation.
 - b. Flush the line to the specimen base with de-aired water from burette No. 1. Valves A, B, E, and I should be open and valve C should be closed.
 - c. Close valve A and refill burette No. 1 with sufficient de-aired water to saturate the specimen plus an additional amount equal to approximately 10 percent of the specimen volume. Then adjust the differential pressure transducer to read zero.
 - d. Reapply a vacuum to burette No. 1 through valve J, using regulator No. 2. Lock the vacuum into the system by closing valve J when the vacuum gage indicates a high vacuum.
 - e. Remove any water in the system to the top of the specimen by applying a small pressure to burette No. 2, using regulator No. 2. Valves F and D should be open and valves C and J should be closed.
 - f. After placing the specimen in the chamber on the previously saturated base and connecting the line to the cap (which should contain a dry porous stone), de-air the specimen by first applying a partial vacuum of 5 psi to the top of the specimen through burette No. 2, using regulator No. 2. The partial vacuum may be read on the differential vacuum gage, valve B should be closed, and valves A, D, and F should be open during this operation.
 - g. When the differential pressure transducer indicates an equilibrium condition under the 5-psi partial vacuum (a reading of zero), slowly increase the partial vacuums acting on the top of the specimen and the chamber maintaining the -5-psi reading on the differential vacuum gage, using regulators 1 and 2 until a full vacuum is acting on the specimen. The differential pressure transducer reading should not indicate an induced effective stress greater than 2 psi during this operation. When the differential pressure transducer indicates an equilibrium condition, a full vacuum will be acting within the specimen and the effective confining pressure will be 5 psi.
 - h. After waiting approximately 10 min or until all of the

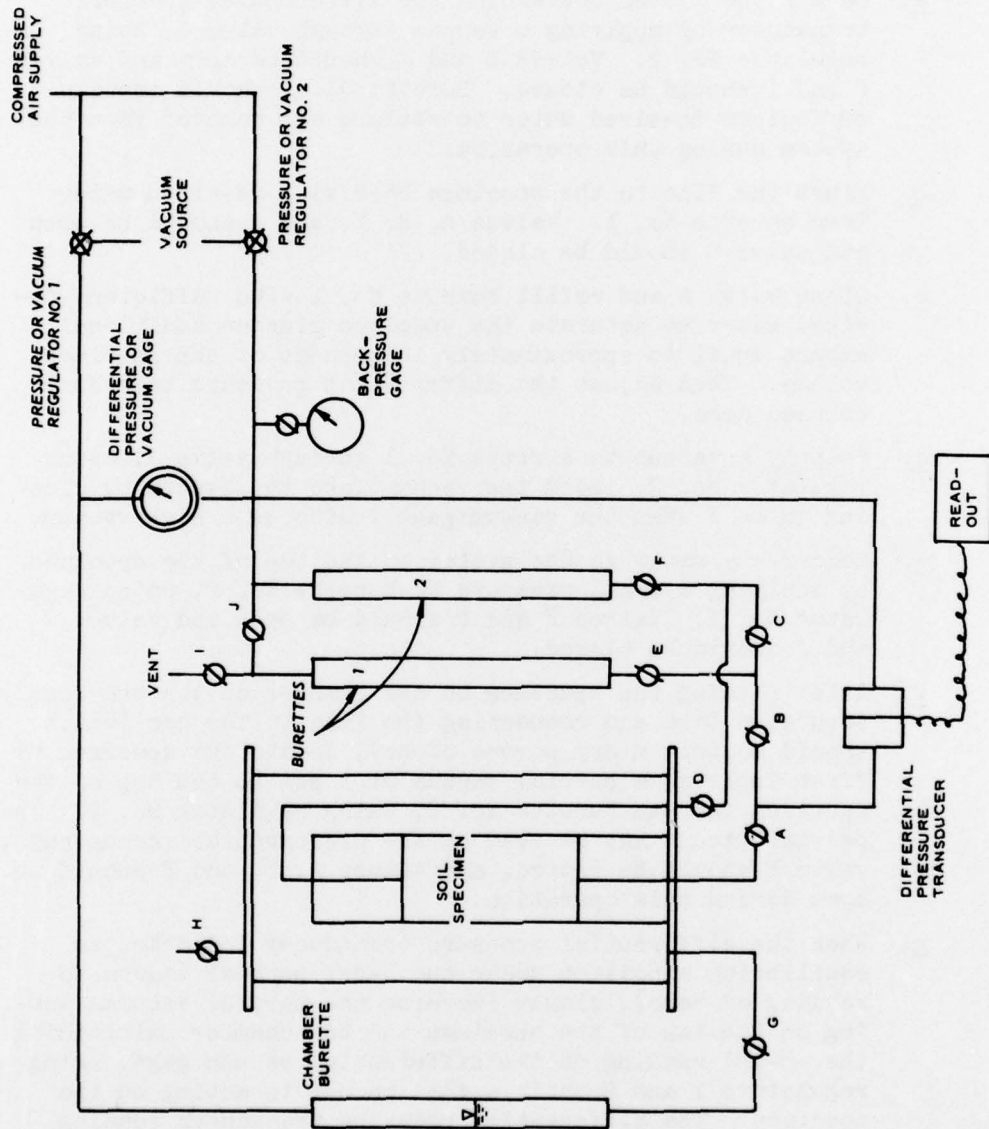

Figure C1. Schematic diagram of the differential vacuum saturation apparatus and pressure control system

remaining air in the specimen is removed, open valve B and then slowly open valve I, thus allowing de-aired water in burette No. 1 to enter the bottom of the specimen under a negative pressure gradient. The gradient under which water flows into the specimen should not exceed -2 psi and may be measured by the differential pressure transducer. It may be controlled by opening and closing valves I and J. Valve I should be opened to increase the gradient, and valve J should be opened to decrease the gradient.

- i. When water appears at the bottom of burette No. 2, continue to allow water to flow through the specimen under the controlled gradient until approximately 10 cc has entered the burette. Apparent air bubbles in the line to the top of the specimen may be due to cavitation of the water.
- j. Close valve B and slowly release the vacuums acting on the top of the specimen and the chamber, using regulators 1 and 2, maintaining the -5-psi reading on the differential vacuum gage and not allowing the differential pressure transducer reading to exceed -2 psi. At the end of this operation, there should be no pressure on the chamber and -5 psi acting on top of the specimen.
- k. After the differential pressure transducer indicates an equilibrium condition, simultaneously reduce the -5-psi partial vacuum acting on the top of the specimen and increase the chamber pressure to 5 psi, using regulators 1 and 2. The chamber pressure may be read on the differential pressure gage.
- l. The back pressure acting on the specimen pore water may now be increased to the expected field hydrostatic condition by opening valve K and increasing the pressures applied by regulators 1 and 2, maintaining the 5-psi differential gage reading until the desired back pressure is read on the back-pressure gage. The differential pressure transducer reading should not exceed 2 psi during this operation.
- m. After the differential pressure transducer reading once again indicates an equilibrium condition, a determination of the pore-water pressure parameter B may be made, and then consolidation and shear of the specimen may proceed in the usual manner.

In accordance with letter from DAEN-RDC, DAEN-ASI dated 22 July 1977, Subject: Facsimile Catalog Cards for Laboratory Technical Publications, a facsimile catalog card in Library of Congress MARC format is reproduced below.

Donaghe, Robert T

Effects of back-pressure saturation techniques on results of \bar{R} triaxial compression tests / by Robert T. Donaghe and Frank C. Townsend. Vicksburg, Miss. : U. S. Waterways Experiment Station ; Springfield, Va. : available from National Technical Information Service, 1979.

44, 147 p. : ill. ; 27 cm. (Miscellaneous paper - U. S. Army Engineer Waterways Experiment Station ; GL-79-12)

Prepared for Office, Chief of Engineers, U. S. Army, Washington, D. C., under CWIS 174.

1. Back pressure. 2. Back pressure saturation. 3. \bar{R} tests (Soils). 4. Saturation (Soils). 5. Triaxial shear tests. I. Townsend, Frank Charles, joint author. II. United States. Army. Corps of Engineers. III. Series: United States. Waterways Experiment Station, Vicksburg, Miss. Miscellaneous paper ; GL-79-12.
TA7.W34m no.GL-79-12