

AD-A071 121

AEROSPACE CORP EL SEGUNDO CALIF AEROPHYSICS LAB
IGNITION OF NF3 WITH HYDROCARBONS AND FLUOROCARBONS.(U)

F/G 21/2

JUN 79 P BREISACHER, W A HICKS

F04701-78-C-0079

UNCLASSIFIED

TR-0079(4725)-2

SAMSO-TR-79-45

NL

| OF |

AD
A071 121



END
DATE
FILMED

8 --79

DDC

LEVEL *II*

12

AD A071121

**Ignition of NF₃ with Hydrocarbons
and Fluorocarbons**

PETER BREISACHER and W. A. HICKS
Aerophysics Laboratory
Laboratory Operations
The Aerospace Corporation
El Segundo, Calif. 90245

7 June 1979

Interim Report

APPROVED FOR PUBLIC RELEASE;
DISTRIBUTION UNLIMITED

DDC
RECEIVED
JUL 13 1979
REGULATED
D

DDC FILE COPY

Prepared for
NAVAL SEA SYSTEMS COMMAND
Washington, D.C. 20362

SPACE AND MISSILE SYSTEMS ORGANIZATION
AIR FORCE SYSTEMS COMMAND
Los Angeles Air Force Station
P.O. Box 92960, Worldway Postal Center
Los Angeles, Calif. 90009

79 07 12 013

This interim report was submitted by The Aerospace Corporation, El Segundo, CA 90245, under Contract No. F04701-78-C-0079 with the Space and Missile Systems Organization, Deputy for Advanced Space Programs, P.O. Box 92960, Worldway Postal Center, Los Angeles, CA 90009. It was reviewed and approved for The Aerospace Corporation by W. R. Warren, Jr., Director, Aerophysics Laboratory. Lieutenant A. G. Fernandez, SAMSO/YCPT, was the project officer for Advanced Space Programs.

This report has been reviewed by the Information Office (OI) and is releasable to the National Technical Information Service (NTIS). At NTIS, it will be available to the general public, including foreign nations.

This technical report has been reviewed and is approved for publication. Publication of this report does not constitute Air Force approval of the report's findings or conclusions. It is published only for the exchange and stimulation of ideas.

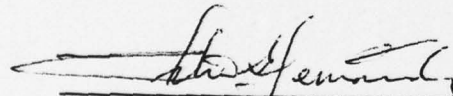
Arturo G. Fernandez, Lt, USAF
Project Officer

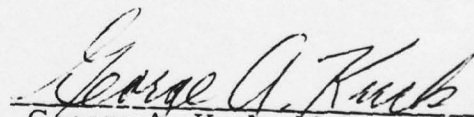
George A. Kuck, Maj., USAF
Chief, Technology Plans Division

FOR THE COMMANDER

FLOYD R. STUART, Colonel, USAF
Asst. Deputy for Technology

UNCLASSIFIED

9/ Interim rept.

SECURITY CLASSIFICATION OF THIS PAGE (When Data Entered)

19 REPORT DOCUMENTATION PAGE		READ INSTRUCTIONS BEFORE COMPLETING FORM
1. REPORT NUMBER SAMSO-TR-79-45	2. GOVT ACCESSION NO.	3. RECIPIENT'S CATALOG NUMBER
4. TITLE (and Subtitle) IGNITION OF NF_3 WITH HYDROCARBONS AND FLUOROCARBONS		5. TYPE OF REPORT & PERIOD COVERED Interim
7. AUTHOR(s) Peter Breisacher and William A. Hicks		14. PERFORMING ORG. REPORT NUMBER TR-0079(4725)-2
9. PERFORMING ORGANIZATION NAME AND ADDRESS The Aerospace Corporation El Segundo, Calif. 90245		15. CONTRACT OR GRANT NUMBER(s) F04701-78-C-0079
11. CONTROLLING OFFICE NAME AND ADDRESS Naval Sea Systems Command Washington, DC 20362		10. PROGRAM ELEMENT, PROJECT, TASK AREA & WORK UNIT NUMBERS
14. MONITORING AGENCY NAME & ADDRESS (if different from Controlling Office) Space and Missile Systems Organization Air Force Systems Command Los Angeles Air Force Station, P. O. Box 92960 Worldway Postal Center Los Angeles, Calif. 90009		12. REPORT DATE 7 June 1979
16. DISTRIBUTION STATEMENT (of this Report) Approved for public release; distribution unlimited.		13. NUMBER OF PAGES 24
15. SECURITY CLASS. (of this report) Unclassified		15a. DECLASSIFICATION/DOWNGRADING SCHEDULE
17. DISTRIBUTION STATEMENT (of the abstract entered in Block 20, if different from Report)		
18. SUPPLEMENTARY NOTES		
19. KEY WORDS (Continue on reverse side if necessary and identify by block number) Spark Ignition N_2F_4 Spontaneous Ignition Gas Analysis Combustion Efficiencies NF_3 and Fuels		
20. ABSTRACT (Continue on reverse side if necessary and identify by block number) The ignition characteristics of NF_3 were studied with several hydrocarbons and fluorocarbons at various initial pressures and reactant concentrations. All tests were conducted statically in an instrumented high-pressure reaction vessel with the use of either spark or hot-wire ignition sources. Product gases were analyzed in order to determine combustion efficiency. Ignition delay, over-pressures, and temperature rise were determined for each test. The optimum oxidizer/fuel ratio for the most complete reaction of NF_3 was determined for mixtures of NF_3 and C_2H_4 ; NF_3 and 1, 3, - C_4H_6 ; NF_3 and		

DD FORM 1473 (FACSIMILE)

409 367 Jue

UNCLASSIFIED

SECURITY CLASSIFICATION OF THIS PAGE (When Data Entered)

UNCLASSIFIED

SECURITY CLASSIFICATION OF THIS PAGE(When Data Entered)

19. KEY WORDS (Continued)

20. ABSTRACT (Continued)

C_5H_6 ; and NF_3 and $C_2H_2F_2$. The feasibility of using N_2F_4 as an injected additive for firing spontaneously spark-ignitable mixtures of NF_3 and C_2H_4 at concentrations of up to 10% N_2F_4 in helium was investigated with negative results.

UNCLASSIFIED

SECURITY CLASSIFICATION OF THIS PAGE(When Data Entered)

CONTENTS

I. INTRODUCTION 5

II. DESCRIPTION OF APPARATUS 7

III. EXPERIMENTAL PROCEDURES 17

IV. EXPERIMENTAL RESULTS 19

V. CONCLUSIONS 25

Accession For	
NTIS GRA&I	<input checked="" type="checkbox"/>
DDC TAB	<input type="checkbox"/>
Unannounced	<input type="checkbox"/>
Justification	
By _____	
Distribution/ _____	
Availability Codes	
Dist	Avail and/or special
A	

DDC
RECEIVED
 JUL 13 1979
 D

TABLES

1.	Properties and Formulas of Fuels	15
2.	Summary of NF_3 Ignition Tests	21

FIGURES

1.	Reaction Vessel	8
2.	Gas-Handling System	9
3.	Gas-Handling Apparatus	10
4.	Data Recording System	12
5.	Typical Oscilloscope Records	13

I. INTRODUCTION

During the past few years, considerable effort has been made to identify the best available combination of reactants required for the generation of sufficiently high fluorine-atom concentrations in a combustion-driven, scaled-up continuous wave HF chemical laser.¹⁻⁶ Alternatives to the use of F_2 , H_2 , and D_2 were sought for reasons of safety, convenience, material expense, and capacity for storage. NF_3 was concluded to have the greatest potential for use as an oxidizer in combination with various hydrocarbon or fluorocarbon fuels. An oxidizer-rich mixture of NF_3 and fuel reacts to form only CH_4 , HF, N_2 , and F_2 . At high chamber temperatures, thermal dissociation of the excess NF_3 produces fluorine atoms. The addition of inert gas to the reactant mixture must be properly adjusted in order to prevent excessive dilution of chamber energy release to where it becomes insufficient to sustain proper NF_3 decomposition rates.

¹ Study and Demonstration of Liquid and Gaseous Reactants for Advanced Chemical Lasers, TRW 26395-6007-RU-00, Final Report, TRW, Inc., One Space Park, Redondo Beach, Calif. (8 April 1975).

² B. Goshgarian, C. Selph, and J. O'Pray, Mass Spectrometric Investigation of Fluorocarbon Flames, AIAA 74-1141, American Institute of Aeronautics and Astronautics, New York (21 Oct 1974).

³ A. Axworthy, E. C. Curtis, and J. F. Hon, Liquid and Gaseous Reactants for Advanced Chemical Lasers, Final Report, Rocketdyne Division, Rockwell International, Canoga Park, Calif. (1 April 1975) (Contract N60921-74-C-0371).

⁴ L. Forman, A. Axworthy, J. Hon, and G. Schneider, Advanced Fuels for Chemical Lasers, AFRPL-TR-75-3, Final Report, Rocketdyne Division, Rockwell International, Canoga Park, Calif. (May 1975) (Contract F04611-72-C-0094).

⁵ E. F. Croomes, "The Combustion of Hydrocarbons and Fluoro-substituted Hydrocarbons with Nitrogen Tetrafluoride-Oxygen Mixtures," Combust. Flame **10**, 71 (1966).

⁶ F. J. Pisacane, E. Baroody, R. Robb, and O. Dengel, "Reaction of NF_3 with Gases and Condensed Matter," 12th JANNAF Combustion Meeting, CPIA 273, Vol. 1, Chemical Propulsion Information Agency, Silver Spring, Maryland (Dec. 1975).

In the conduct of NF_3 combustion tests with C_2H_4 , some difficulty was encountered in igniting the mixture at desired chamber conditions and mixture ratios. The problem was circumvented by using a small amount of F_2 pilot gas to initiate the reaction with C_2H_4 or other fuels. Although this action produced satisfactory results,⁷ it did, however, defeat the objective of eliminating the need to carry hazardous F_2 . The primary objective of the work reported herein was to investigate the conditions required for the efficient ignition and burning of various oxidizer/fuel mixtures by using simple spark or hot-wire ignition sources. The ignition characteristics of N_2F_4 as a spontaneous ignitor of combustible mixtures of NF_3 and C_2H_4 were also studied. The reaction of several other fuels with NF_3 was also investigated to determine the feasibility of their use rather than C_2H_4 .

⁷Project 2454, Module Verification Test Report, TRW M-1384, TRW, Inc., One Space Park, Redondo Beach, Calif. (8 Feb. 1978).

II. DESCRIPTION OF APPARATUS

A high-pressure, stainless steel reaction vessel (Fig. 1) was modified to accommodate a fast-opening, remotely operated pneumatic ball valve (Whitey SS 44S6-133 NC), a thermocouple (Chromel Alumel), a pressure transducer (Kistler Quartz), and a spark plug or glow heater. A long-reach spark plug (NGK D7ES, 0.060-in. gap) was used to place the ignition source as far as possible into the reaction vessel. The thermocouple could be moved over the entire depth of the reaction vessel if required, and the pressure transducer was in a fixed position near the vessel lid. The glow wire, constructed of Pt-10% Rh wire, was welded directly to the terminals of a modified spark plug.

Calibration of the pressure transducer was performed statically with the detector in its normal position. Operation of the transducer was periodically checked by injecting helium at high pressure into the reaction vessel at various initial pressures. In this way, a complete calibration could be performed over the range of initial and final total pressures to be investigated. A teflon-clad stirring bar was placed at the bottom of the vessel for thorough mixing of the reactants before ignition.

The gas-handling system (Fig. 2) was constructed of stainless steel. C_2H_4 was added directly from a small cylinder, NF_3 was transferred from a large reservoir to a 1-liter stainless steel cylinder at 100 psi, N_2F_4 was transferred from another supply to a similar 1-liter stainless steel container. Mixtures of 2.5 to 10% N_2F_4 in helium were prepared at total pressures to 3 atm. Other fuels used were transferred directly from their cylinders or, if in liquid form, contained in metal storage tubes. The entire apparatus was located inside a well-vented fume hood (Fig. 3).

Safety shields were placed in front of the reaction vessel and the system was evacuated by exhausting a pump directly into the hood duct. All gas

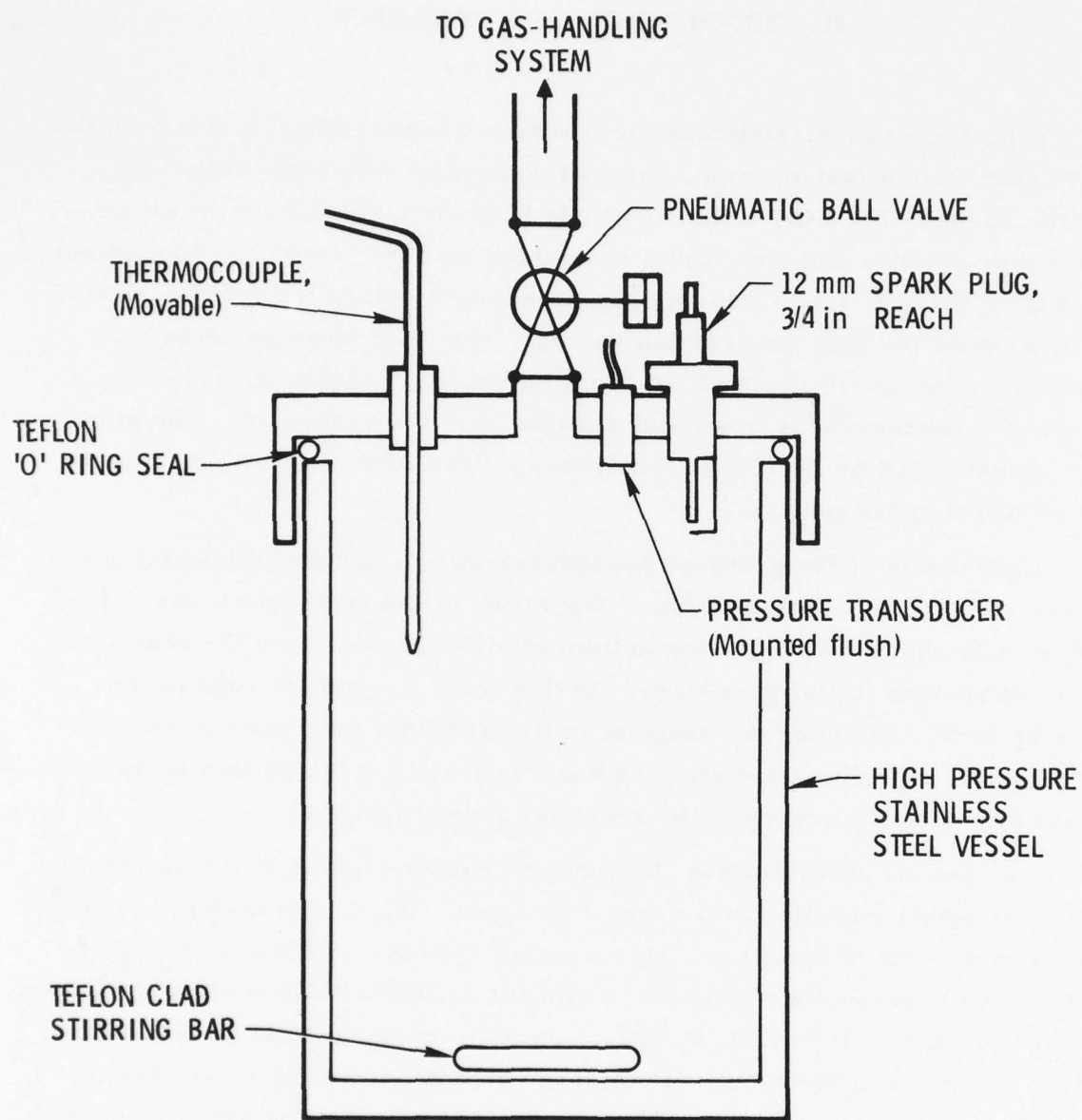
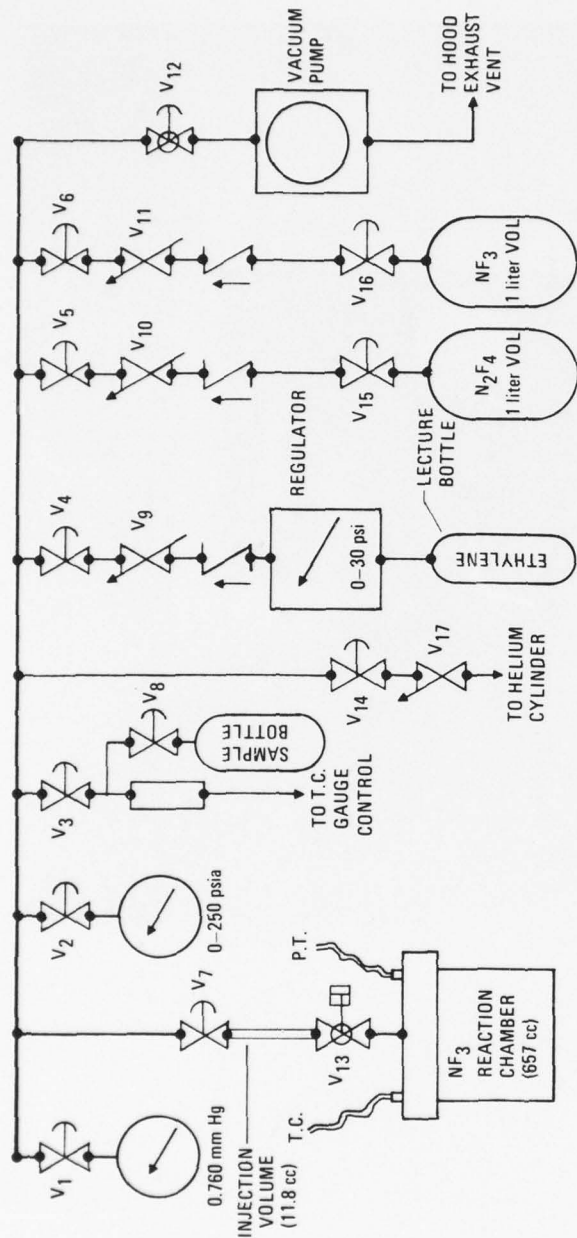

Figure 1. Reaction Vessel



THERMOCOUPLE: CHROMEL ALUMEL
 PRESSURE TRANSDUCER: KISTLER QUARTZ
 PRESSURE TRANSDUCER WITH TYPE 504
 CHARGE AMPLIFIER
 SPARK PLUG: NGK TYPE D7ES
 12 mm DIA x 3/4 in. REACH (0.060 in. gap)
 PNEUMATIC VALVE: 3/8 in. WHITEY BALL VALVE
 TYPE SS-4456-133 Nc

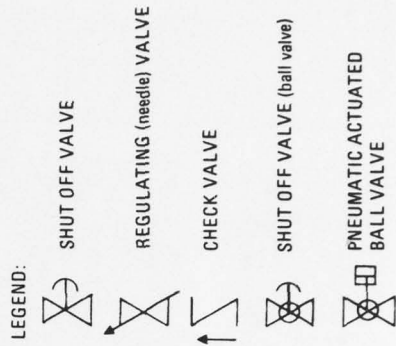

Figure 2. Gas-Handling System

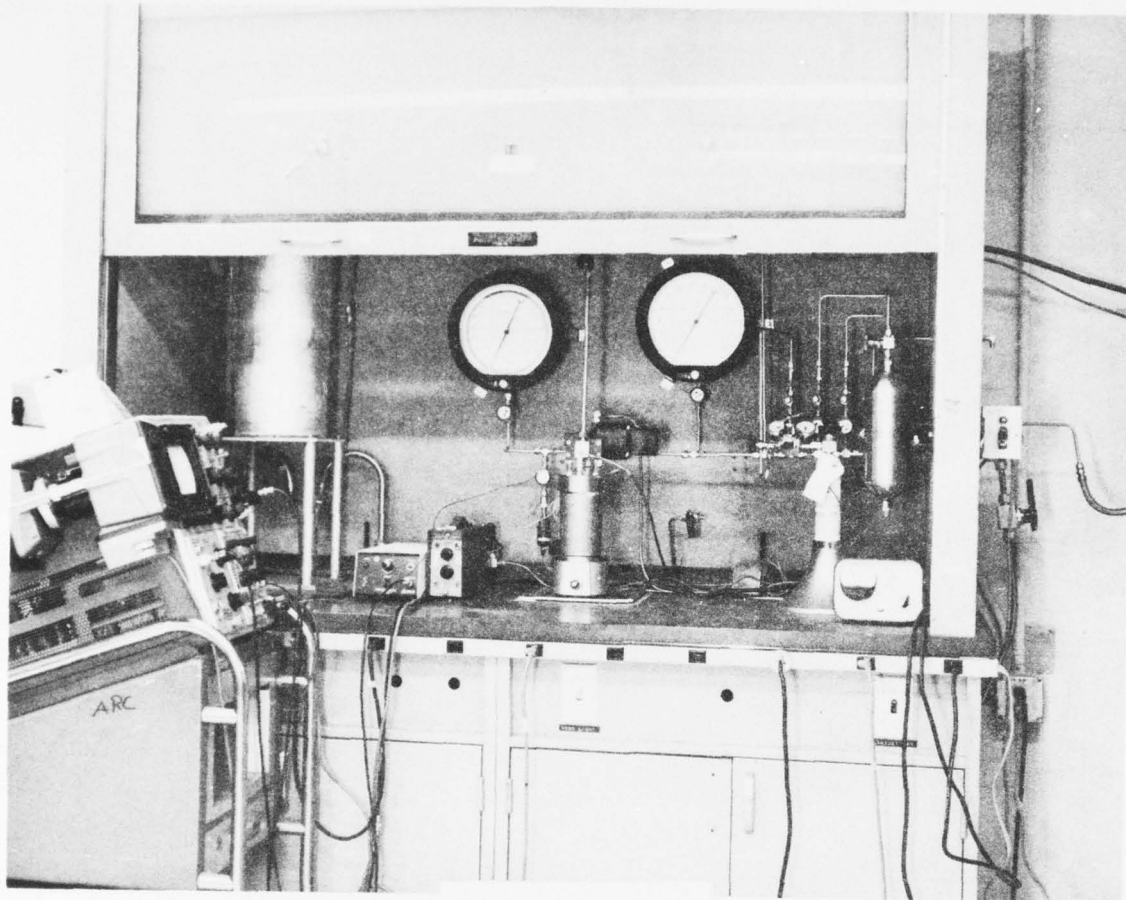

Figure 3. Gas-Handling Apparatus

sample and storage bottles were thoroughly cleaned and passivated prior to use. The system was continually evacuated to $\sim 75 \mu\text{m}$ when not in use. Continuous passivation was effected by the F_2 produced during the ignition tests and the system was always vented in helium. Data records were obtained on a Techtronix 551 dual-beam oscilloscope (Fig. 4). The spark was fired by using an EG&G model TM-12A trigger module. Some typical data records for different combinations of NF_3 and fuels are shown in Fig. 5.

Gas analysis of NF_3 , C_2H_4 , HF , CF_4 , N_2 and N_2F_4 was carried out by gas chromatography. Trace impurities in any of the reactants can be measured through mass spectrometry or infrared analysis, neither of which was conducted during these tests. On the basis of the assumption that little reactants other than the compounds NF_3 ; C_2H_4 ; HF ; F_2 ; N_2 ; CF_4 ; $\text{C}_2\text{H}_2\text{F}_2$; 1, 3, C_4H_6 ; and C_5H_6 would appear, an analytical system that consisted of four separate columns operating in two gas chromatographs was built and tested. Initially, many of the column materials described in the literature failed to show proper separation for CF_4 , NF_3 , F_2 , or HF .^{8,9} Several materials were properly prepared but yielded unsatisfactory results. Finally, a system of columns was developed with separate 22- and 4-ft, 60- to 80-mesh silica gel columns plus a 10-ft Halocarbon oil 1321 on Kel F 300 D powder and a 10-ft didecylphthalate on a GC22 firebrick column. With this system, all compounds except F_2 were separated. Efforts to detect F_2 on the Kel-F column were unsuccessful despite the clear separation of this

⁸ A. B. Richmond, "Separation of Nitrogen Fluoride from Carbon Tetrafluoride by Gas Chromatography," *Anal.Chem.* 33 (12), 1806 (1961).

⁹ L. A. Dee, *Analysis of Nitrogen Trifluoride*, AFRPL-TR-76-20, Air Force Rocket Propulsion Laboratory, Edwards Air Force Base, Calif. (April 1976).

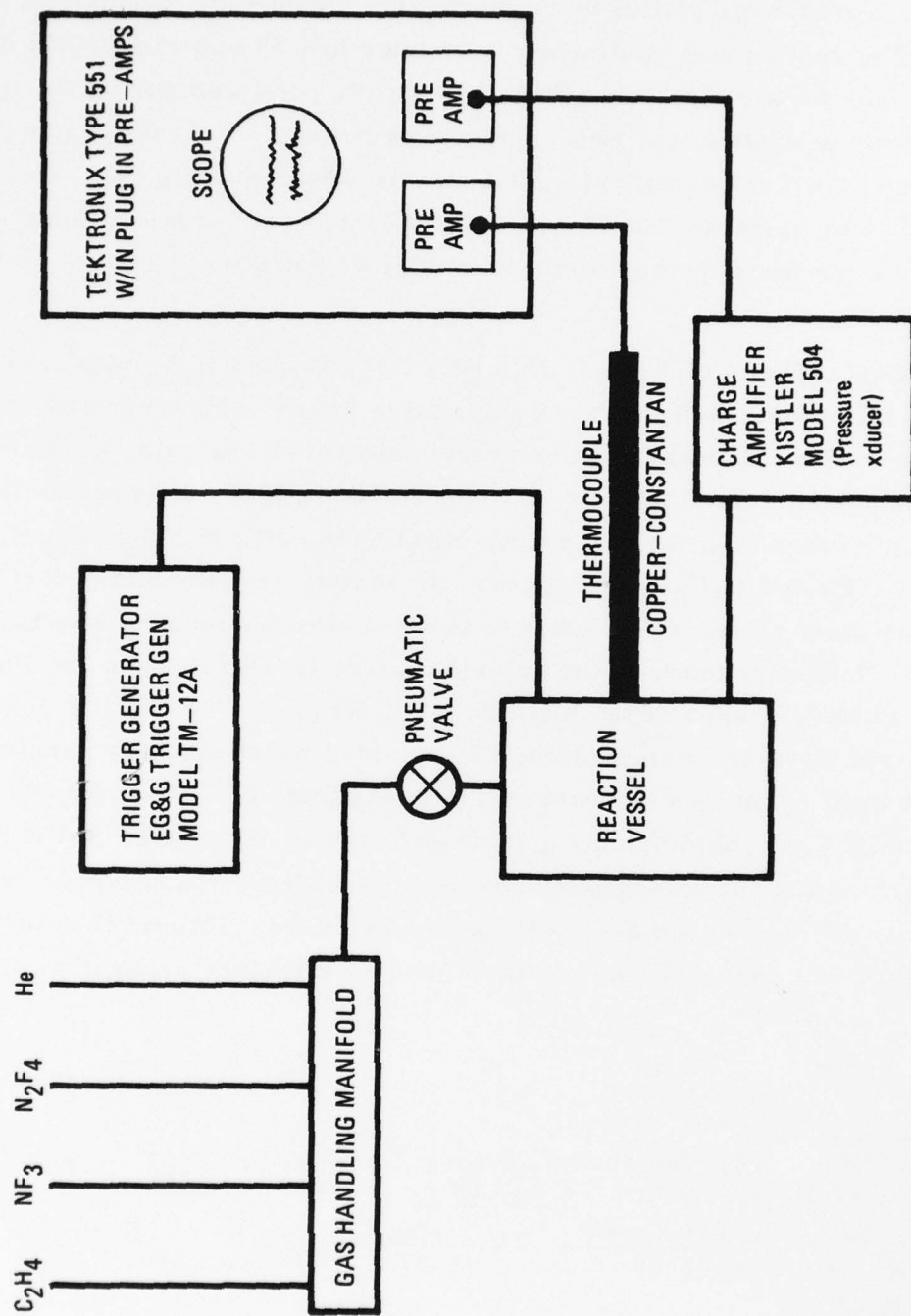
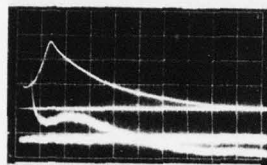
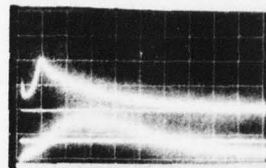

Figure 4. Data-Recording System



$\text{NF}_3/\text{C}_2\text{H}_4$ 10:1



$\text{NF}_3/\text{O}_2\text{H}_2\text{F}_2$ 5:1

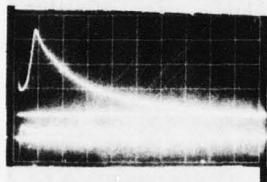

$\text{NF}_3/\text{C}_2\text{H}_4$ 8:1

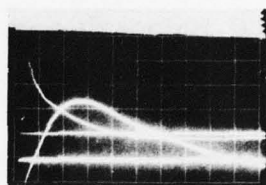

$\text{NF}_3/\text{C}_2\text{H}_2\text{F}_2$ 2:1

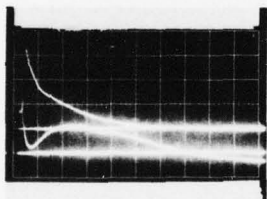

$\text{NF}_3/\text{C}_2\text{H}_4$ 5:1

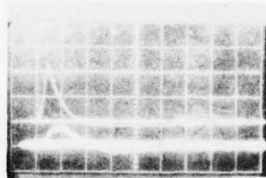

$\text{NF}_3/\text{C}_4\text{H}_6$ 20:1 GLO-PLUG

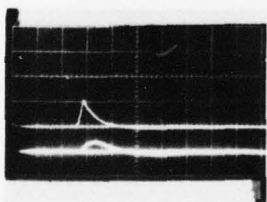

$\text{NF}_3/\text{C}_2\text{H}_4$ 10:1 GLO-PLUG

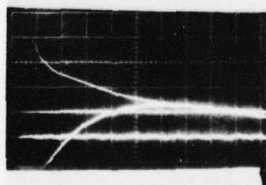

$\text{NF}_3/\text{C}_5\text{H}_6$ 20:1

Figure 5. Typical Oscilloscope Records. Upper trace, pressure; lower trace, temperature

compound from HF in a similar column.¹⁰ It was therefore assumed that the balance of any fluorine unaccounted for in the analysis of both reactants and products would appear as F₂.

Difficulties in the separation of NF₃ and CF₄ were overcome by lengthening a silica gel column to 22 ft, where elution times are 19.5 and 21.5 min for CF₄ and NF₃, respectively. The 4-ft silica gel column was used for N₂, C₂H₄, and other hydrocarbons if required. Elution times were as follows: N₂, 0.6 min; NF₃ + CF₄, 1.8 min; C₂H₆, 6.8 min; CO₂, 8.8 min; C₂F₆, 11 min; C₂H₄, 13.5 min; and C₂H₂F₂, 16.5 min. HF was eluted on the Kel F-Halocarbon oil columns in 5.8 min. Butadiene (1, 3-C₄H₆) and isopropenylacetylene (C₅H₆) were eluted on the didecylphthalate column in 2.2 and 8.5 min, respectively. The columns were periodically calibrated with the use of known mixtures of each of the compounds being analyzed. Structural and empirical formulas of the fuels used are given in Table 1.

¹⁰I. Lysyj and P. R. Newton, "Evaluation of Gas Chromatographic Columns for the Separation of Fluorinated Materials," Anal. Chem. 35 (1), 90 (1963).

Table 1. Properties and Formulas of Fuels

Formula	Structural Formula	Boiling Point, °C	Name
1, 3-C ₄ H ₆	CH ₂ = CHCH = CH ₂	-3	1, 3 Butadiene
C ₂ H ₂ F ₂	CHF = CHF	10-11	Ethylene Difluoride
C ₅ H ₆	CH ₂ ≡ (CH ₃) CC = CH	32	Isopropenylacetylene
C ₂ H ₄	CH ₂ = CH ₂	-104	Ethylene

III. EXPERIMENTAL PROCEDURES

The gas-handling system was completely evacuated to $\sim 75 \mu\text{m}$. Attached to the system was a stainless steel gas sample bottle. The fuel, oxidizer, and helium were loaded into the reaction vessel and gas sample bottle in the desired ratio for a particular test. A fixed amount of time was assigned to mixing within the reaction vessel. During this period, the system was again evacuated, and the unreacted gas sample mixture was removed for analysis. Another sample bottle, which was to receive the reacted gas mixture was attached and evacuated. In order to ensure that proper mixing had occurred both in the reaction vessel and sample bottle, the following test was performed. After initial gas loading, the sample bottle was analyzed for NF_3 and hydrocarbon. The gas contained in the reaction vessel was then analyzed by expanding it into a gas sample bottle without any mixing. These procedures were repeated with a thoroughly mixed reaction vessel sample. No differences were noted in the NF_3 /hydrocarbon ratio for any pair of gas mixtures.

Before the first ignition test, the expansion volume of the entire system was measured with and without the gas sample bottles. A new measurement was made after each modification of the system. After each ignition, the gases in the reaction vessel were expanded into the system, and pressures were noted as a function of time. A slow decline in pressure occurred for a few minutes before final stabilization. The expanded pressure was then related to the final pressure in the reaction vessel shortly after ignition. The small decrease in pressure from initial values might have resulted from the absorption of F_2 on system walls, which can be considered as a continual passivation of the metal system.

For the additive injection experiments, the mixture of NF_3 and fuel was loaded into the reaction vessel as described previously. The system

was evacuated, and the N_2F_4 and helium were loaded at various pressures into the injection volume tube, modified by double-jacketing for safety. In order to ensure proper mixing of the compounds, another mixing test was conducted in a small gas sample bottle fitted with a magnetic stirring bar and loaded with 1, 3 butadiene and helium at various pressure ratios. If there is separation or poor mixing, an analysis sequence of fresh unmixed, mixed, and long-term stored (vertically) mixtures would reveal different C_4H_6 1, 3/He ratios. Since such differences were not noted, we believe that the N_2F_4 and helium in the injection volume were adequately mixed. The oscilloscope was triggered just before the pneumatic valve was opened in order to record any evidence of spontaneous ignition.

IV. EXPERIMENTAL RESULTS

Before carrying out ignition tests with NF_3 , the performance characteristics of the entire gas-handling system were investigated, particularly the reaction vessel, with the use of known flammable mixtures of C_2H_4 and air. This investigation permitted testing of the temperature and pressure sensing systems probes and also revealed any peculiarities of the entire system with regard to ignition limits of known C_2H_4 -air mixtures. Results indicated that, after adjustments to the initial electronic readout system, particularly adjustments related to high-voltage interferences on the temperature recording channel, systematic and reproducible temperature-pressure records could be obtained for mixtures of C_2H_4 and air down to about 7 vol% C_2H_4 . This value is somewhat higher than the known lower combustibility limit of 3%, but was believed to be adequate for the purposes of this study. All mixtures of NF_3 and fuel were ignited at 1 atm initial pressure. Because of the special interest in C_2H_4 , the range of starting pressures was extended from 0.8 to 2 atm. Upper combustion limits (based on molar ratios) were determined to be useful if gas analysis indicated that most of the NF_3 and fuel were reacted. In some cases, upper ignition limits were directly determined by a failure to ignite. Lower limits were not determined because it was not desirable to operate at molar limits where carbon particulates would develop within the reaction vessel. The fuels used other than C_2H_4 were selected on the basis of maximizing the F_2/NF_3 and F_2/HF production ratio.

Ethylene could be spark ignited easily up to an oxidizer/fuel ratio of 10/1 at initial pressures of 0.8 to 2.0 atm. Ignition with an unsophisticated glow-wire ignitor was also conducted at an oxidizer/fuel ratio of 10/1. The combustion efficiency was somewhat low. Ethylene difluoride could be ignited only at an oxidizer/fuel ratio of 6/1 or lower, a ratio at which this fuel does not appear to be useful. Butadiene was ignitable up to 25/1 $\text{NF}_3/\text{C}_4\text{H}_6$ mole ratio, above which no efforts were made to ignite this fuel because it was

apparent from the gas analysis that the extent of NF_3 reaction was already declining from that obtained at the 20/1 oxidizer/fuel ratio. Glow-wire ignition of this fuel was also possible up to a ratio of 25/1. The efficiency of combustion was almost identical with a glow coil and with a spark at the same mixture ratio. Isopropenylacetylene was ignitable at a mixture ratio of 20/1 and had good combustion efficiency. This compound can be easily handled and stored. The results of these tests are summarized in Table 2. Analytical data occasionally indicated slight excesses in mass balances, which were arbitrarily rounded off to 100%. Temperature, pressure, and ignition delay times are accurate but should not be interpreted analytically because the specific location of the sensors and the geometry of the reaction vessel may significantly affect the results. In general, tests carried out at the same pressures and mixture ratios had similar electronic results.

Gas charges of 2.5 to 10.0 vol % N_2F_4 in helium were injected into mixtures of 10/1 NF_3 and C_2H_4 in the reaction vessel at 1 atm. Injector pressures were from 1.25 to 3 atm. Oscilloscope data indicated that no spontaneous ignition occurred at any of the starting conditions.

Table 2. Summary of NF₃ Ignition Tests

Reactants	Total Initial Pressure, atm	NF ₃ , mol %	Fuel, mol %	Ratio	Time Delay, msec	ΔP, psi	ΔT, °C	Amt. Reacted, % NF ₃	Amt. Expected Found, % $\frac{CF}{N_2}$	HF
NF ₃ -C ₂ H ₄	1.0	33.6	3.4	10/1	12	32				
NF ₃ -C ₂ H ₄	1.0	34.1	3.4	10/1	12	35				
NF ₃ -C ₂ H ₄	1.0	34.1	3.4	10/1	12	32				
NF ₃ -C ₂ H ₄	1.0	33.6	3.4	10/1	13	34				
NF ₃ -C ₂ H ₄	1.0	33.6	3.4	10/1	12	32				
NF ₃ -C ₂ H ₄	1.0	33.6	3.4	10/1	17	30				
NF ₃ -C ₂ H ₄	1.0	33.6	3.4	10/1	12	30				
NF ₃ -C ₂ H ₄	1.0	33.6	3.4	10/1	16	31	25			
NF ₃ -C ₂ H ₄	1.0	33.6	3.4	10/1	14	31	30			
NF ₃ -C ₂ H ₄	1.0	33.6	3.4	10/1	16	32	30			
NF ₃ -C ₂ H ₄	1.0	33.6	3.4	10/1	15	31	26			
NF ₃ -C ₂ H ₄	1.0	33.6	3.4	10/1	12	35	40			
NF ₃ -C ₂ H ₄	1.0	33.6	3.4	10/1	12	34	39			
NF ₃ -C ₂ H ₄	1.0	33.6	3.4	10/1	13	31	34			
NF ₃ -C ₂ H ₄	1.0	33.6	3.4	10/1	13	32	31			
NF ₃ -C ₂ H ₄	1.0	33.6	3.4	10/1	12	38	44			
NF ₃ -C ₂ H ₄	1.0	33.6	3.4	10/1	16	30	25			
NF ₃ -C ₂ H ₄	1.0	33.6	3.4	10/1	16	32	35			
NF ₃ -C ₂ H ₄	1.0	34.1	3.4	10/1	23	28	10			
NF ₃ -C ₂ H ₄	1.0	34.1	3.4	10/1	26	28	9	88	100	86
NF ₃ -C ₂ H ₄	1.0	34.1	3.4	10/1	24	30	11	87	100	91
NF ₃ -C ₂ H ₄	0.8	34.2	3.4	10/1	30	22	6	80	100	100
NF ₃ -C ₂ H ₄	0.8	34.2	3.4	10/1				80	100	100

Table 2. Summary of NF₃ Ignition Tests (Continued)

Reactants	Total Initial Pressure, atm	NF ₃ , mol %	Fuel, mol %	Ratio	Time Delay, msec	ΔP, psi	ΔT, °C	Amt. Reacted, % NF ₃	Amt. Reacted, % Fuel	Amt. Expected Found, % CF ₄	Amt. Expected Found, % N ₂	Amt. Expected Found, % HF
NF ₃ -C ₄ H ₆	1.0	52.6	2.6	20/1	44	31	26	87	100	100	66	100
NF ₃ -C ₄ H ₆	1.0	52.6	2.1	25/1	52	24	20					
NF ₃ -C ₄ H ₆	1.0	52.6	2.6	20/1	24	32	35	87	100	100	70	100
NF ₃ -C ₄ H ₆	1.0	52.6	2.1	25/1	56	21	21	63	100	100	67	100
NF ₃ -C ₄ H ₆	1.0	52.6	2.6	20/1	32	27						
NF ₃ -C ₄ H ₆	1.0	52.6	2.6	20/1	24	33	15	88	100	100	79	100
NF ₃ -C ₄ H ₆	1.0	52.6	2.1	25/1	54	29	11	67	100	100	76	100
NF ₃ -C ₄ H ₆ *	1.0	52.6	2.6	20/1								
NF ₃ -C ₄ H ₆ *	1.0	52.6	2.6	20/1				87	100	100	82	100
NF ₃ -C ₄ H ₆ *	1.0	52.6	2.6	20/1		33	15	87	100	100	80	100
NF ₃ -C ₄ H ₆ *	1.0	52.6	2.1	25/1	23		11					
NF ₃ -C ₄ H ₆ *	1.0	52.6	2.1	25/1	23		9	65	100	100	85	100
NF ₃ -C ₅ H ₆	1.0	52.6	2.6	20/1			46	100	100	100	70	100
NF ₃ -C ₅ H ₆	1.0	52.6	2.6	20/1	9	87.8	6.3					
NF ₃ -C ₅ H ₆	1.0	52.6	2.6	20/1	8	98.5	49.0					
NF ₃ -C ₅ H ₆	1.0	51.3	2.6	19.5/1	10	89.5	22.8					
NF ₃ -C ₅ H ₆	1.0	65.8	2.6	25/1	12	80.3	27.4					
NF ₃ -C ₅ H ₆	1.0	65.8	2.6	25/1	18	85	14.7					
NF ₃ -C ₅ H ₆	1.0	65.8	2.6	25/1	13	82	15.5					
NF ₃ -C ₅ H ₆	1.0	65.8	2.6	25/1	18	80.1						
NF ₃ -C ₅ H ₆	1.0	50.6	2.6	19.25/1	13	91	18.4					

Table 2. Summary of NF₃ Ignition Tests (Continued)

Reactants	Total Initial Pressure, atm	NF ₃ , mol. %	Fuel, mol. %	Ratio	Time Delay, msec	ΔP , psi	ΔT , °C	Amt. Reacted, % NF ₃	Amt. Expected Found, % $\frac{CF_4}{N_2}$	HF
NF ₃ -C ₂ H ₄	0.8	34.2	3.4	10/1	27	25		88	100	100
NF ₃ -C ₂ H ₄	0.8	34.2	3.4	10/1	24	21	13	87	100	100
NF ₃ -C ₂ H ₄	0.8	34.2	3.4	10/1	26	22		87	100	100
NF ₃ -C ₂ H ₄	1.0	32.0	3.9	8/1	14	36		100	100	87
NF ₃ -C ₂ H ₄	1.0	32.0	3.9	8/1	14	35		100	100	83
NF ₃ -C ₂ H ₄	2.0	34.0	3.4	10/1	14	65	9			
NF ₃ -C ₂ H ₄	2.0	39.0	3.9	10/1	17	80	31	94	100	80
NF ₃ -C ₂ H ₄	2.0	39.0	3.9	10/1	9	100	29	95	100	92
NF ₃ -C ₂ H ₄	2.0	35.5	3.9	8/1	9	100		100	91	77
NF ₃ -C ₂ H ₄	2.0	35.5	3.9	8/1			29	100	100	75
NF ₃ -C ₂ H ₄	1.0	34.2	3.4	10/1		20	11	75	100	89
NF ₃ -C ₂ H ₄ *	1.0	34.2	3.4	10/1	No Ignition					
NF ₃ -C ₂ H ₂ F ₂	1.0	34.2	3.4	10/1	No Ignition					
NF ₃ -C ₂ H ₂ F ₂	1.0	34.2	3.5	10/1	No Ignition					
NF ₃ -C ₂ H ₂ F ₂	1.0	27.6	3.9	6/1	No Ignition					
NF ₃ -C ₂ H ₂ F ₂	1.0	26.3	13.1	2/1	5	47				
NF ₃ -C ₂ H ₂ F ₂	1.0	32.7	6.5	5/1	15	42	15	100	100	100
NF ₃ -C ₂ H ₂ F ₂	1.0	26.3	13.1	2/1	6	61	49			
NF ₃ -C ₂ H ₂ F ₂	1.0	35.7	6.6	5.4/1	15	49	22			
NF ₃ -C ₂ H ₂ F ₂	1.0	34.9	5.4	6.5/1	No Ignition					
NF ₃ -C ₂ H ₂ F ₂	1.0	31.1	5.2	6/1	No Ignition					
NF ₃ -C ₂ H ₂ F ₂	1.0	33.0	6.6	5/1	15	42	15			
NF ₃ -C ₂ H ₂ F ₂	1.0	32.7	6.6	5/1	16	38	8			
NF ₃ -C ₄ H ₆	1.0	52.6	2.6	20/1						

V. CONCLUSIONS

Spark or hot-wire ignitions of mixtures of NF_3 and several hydrocarbon or fluorocarbon fuels were accomplished statically in a high-pressure reaction vessel. Product gas composition, pressure and temperature rise, and ignition delay were measured to determine the physical and compositional conditions necessary for smooth, rapid initiation of combustion. Oxidizer-rich mixtures were used in all tests. Combustion was always very efficient within the range of reactant concentrations used. No elemental carbon was found; the total carbon input was usually accounted for by the CF_4 present in the product gases.

Since C_2H_4 was determined to be the fuel of choice, more comprehensive testing was conducted with this compound than with any of the others. Tests were carried out over an initial total pressure range of 0.8 to 2.0 atm and molar ratios of 8/1 to 10/1, $\text{NF}_3/\text{C}_2\text{H}_4$. In all cases, combustion efficiencies were nearly 100% within the regime of the aforementioned range of initial conditions. The criteria for establishing combustion efficiency were based on the amount of NF_3 reacted and the amount of CF_4 found from the total carbon input. Small differences were noted in burning efficiencies when spark and glow-coil initiation tests were compared under identical conditions. A more sophisticated design for the hot-wire source and the method of activation might have reduced these differences in performance.

Little significance can be placed on the ignition delay times and the temperature and pressure pulses because of the restricted locations of these sensors and the specific geometry of the reaction vessel. Full-scale dynamic tests in an applicable combustor under the conditions used in these tests may confirm the very short ignition delays and moderate over-pressure recorded. Product gas analysis results were closely related to temperature, pressure, and ignition delay measurements in repetitive tests of the same mixtures of

NF_3 and fuel at the same starting conditions. In this way, the monitoring of problems related to spark triggering, incomplete mixing, and detector function could be controlled.

Of the remaining fuels tested, theoretically, butadiene 1, 3- C_4H_6 would be the most effective used if complete combustion were to occur. The molar ratio of HF/NF_3 and F_2/NF_3 produced would be 0.3 for HF and 0.95 for each mole of NF_3 reacted, compared with 0.4 and 0.90 for C_2H_4 . Mixtures of 20/1 NF_3 and C_4H_6 and 10/1 NF_3 and C_2H_4 were compared. Complete combustion of isopropenylacetylene (C_5H_6) with NF_3 at similar fuel-lean mixture ratios (1/20) would show a slightly lower theoretical F_2/NF_3 production ratio.

Theoretically, ethylene difluoride would be the best fuel to use if the ratio of HF/NF_3 were to be minimized and F_2/NF_3 maximized. At a molar ratio of 10/1 $\text{NF}_3/\text{C}_2\text{H}_2\text{F}_2$, the ratio of HF/NF_3 would be 0.2, considerably better than that achieved with butadiene (0.3). The ratio of F_2/NF_3 would be 1.1, which compares favorably with that obtained with butadiene (0.95). Because of the inability to ignite mixtures of NF_3 and $\text{C}_2\text{H}_2\text{F}_2$ at molar ratios greater than 5/1 to 6/1 by the methods reported here, this fuel was no longer considered as an alternative for C_2H_4 .

The failure to ignite spontaneously combustible mixtures of NF_3 and C_2H_4 with the use of very dilute N_2F_4 -He injection mixtures should not be considered as a final conclusion for the following reasons:

1. The experimental tests were conducted with an injection system that could be greatly improved.
2. The probability of shock front heating of the N_2F_4 was not assured because of limitations imposed by safety and equipment considerations.
3. The remotely operated ball valve should be replaced by a diaphragm or a much faster opening valve.
4. The allowable N_2F_4 concentration should be increased considerably over that used.
5. The maximum total pressure and volume of the injection volume should be increased.

Results of the static ignition tests reported herein indicate that NF_3 can be successfully ignited in a combustor by using a spark or hot-wire ignition source at subatmospheric and elevated chamber pressures and optimum oxidizer/fuel mixture ratios. These results should be confirmed in full-scale combustor tests.

LABORATORY OPERATIONS

The Laboratory Operations of The Aerospace Corporation is conducting experimental and theoretical investigations necessary for the evaluation and application of scientific advances to new military concepts and systems. Versatility and flexibility have been developed to a high degree by the laboratory personnel in dealing with the many problems encountered in the nation's rapidly developing space and missile systems. Expertise in the latest scientific developments is vital to the accomplishment of tasks related to these problems. The laboratories that contribute to this research are:

Aerophysics Laboratory: Launch and reentry aerodynamics, heat transfer, reentry physics, chemical kinetics, structural mechanics, flight dynamics, atmospheric pollution, and high-power gas lasers.

Chemistry and Physics Laboratory: Atmospheric reactions and atmospheric optics, chemical reactions in polluted atmospheres, chemical reactions of excited species in rocket plumes, chemical thermodynamics, plasma and laser-induced reactions, laser chemistry, propulsion chemistry, space vacuum and radiation effects on materials, lubrication and surface phenomena, photo-sensitive materials and sensors, high precision laser ranging, and the application of physics and chemistry to problems of law enforcement and biomedicine.

Electronics Research Laboratory: Electromagnetic theory, devices, and propagation phenomena, including plasma electromagnetics; quantum electronics, lasers, and electro-optics; communication sciences, applied electronics, semiconducting, superconducting, and crystal device physics, optical and acoustical imaging; atmospheric pollution; millimeter wave and far-infrared technology.

Materials Sciences Laboratory: Development of new materials; metal matrix composites and new forms of carbon; test and evaluation of graphite and ceramics in reentry; spacecraft materials and electronic components in nuclear weapons environment; application of fracture mechanics to stress corrosion and fatigue-induced fractures in structural metals.

Space Sciences Laboratory: Atmospheric and ionospheric physics, radiation from the atmosphere, density and composition of the atmosphere, aurorae and airglow; magnetospheric physics, cosmic rays, generation and propagation of plasma waves in the magnetosphere; solar physics, studies of solar magnetic fields; space astronomy, x-ray astronomy; the effects of nuclear explosions, magnetic storms, and solar activity on the earth's atmosphere, ionosphere, and magnetosphere; the effects of optical, electromagnetic, and particulate radiations in space on space systems.

THE AEROSPACE CORPORATION
El Segundo, California