

AD-A071 365

AERONAUTICAL RESEARCH LABS MELBOURNE (AUSTRALIA)
THE AERODYNAMICS DIVISION AIRBORNE DATA ACQUISITION PACKAGE TES--ETC(U)
MAR 79 P FERRAROTTO

F/G 14/2

UNCLASSIFIED

ARL/AERO-TM-312

NL

| OF |
AD
A071365

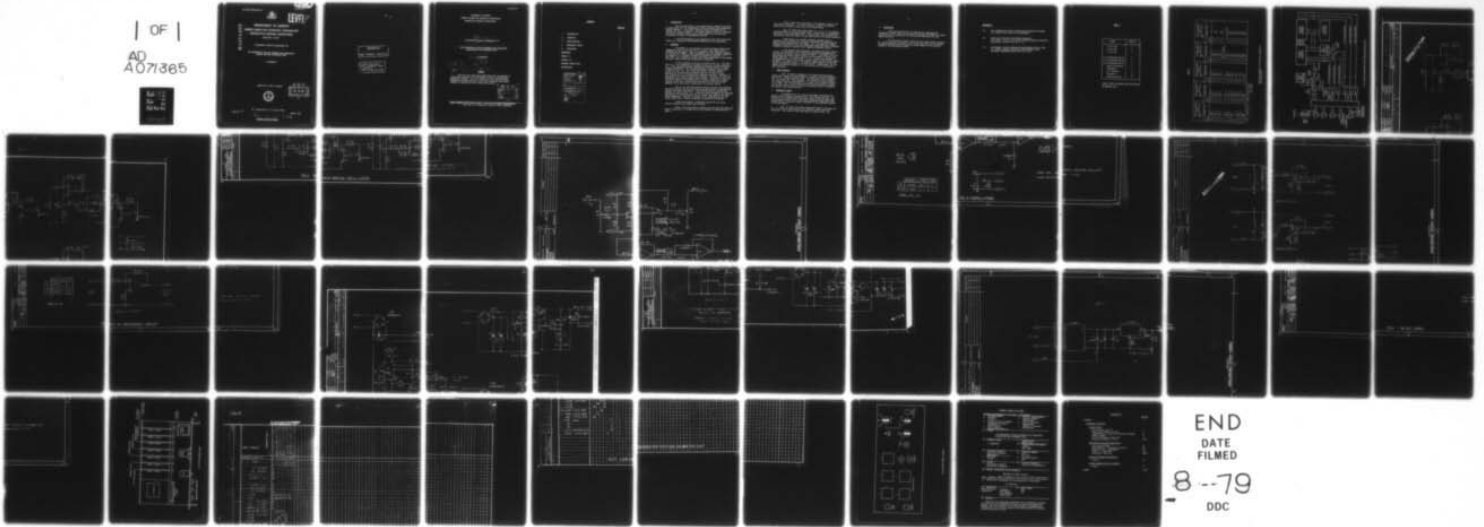

END
DATE
FILMED
8--79
DOC

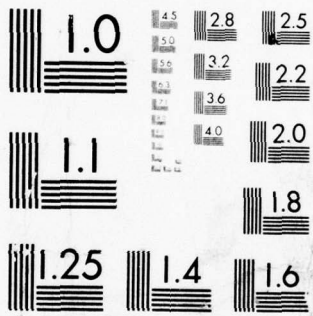

MICROCOPY RESOLUTION TEST CHART
 NATIONAL BUREAU OF STANDARDS-1963-A



LEVEL II

AD A 071365

**DEPARTMENT OF DEFENCE
DEFENCE SCIENCE AND TECHNOLOGY ORGANISATION
AERONAUTICAL RESEARCH LABORATORIES**

MELBOURNE, VICTORIA

Aerodynamics Technical Memorandum 312

THE AERODYNAMICS DIVISION AIRBORNE DATA ACQUISITION
PACKAGE TEST AND CALIBRATION UNIT.

P. FERRAROTTO

Approved for Public Release.



**DDC
RECEIVED
JUL 19 1979
REGISTERED
D**

COPY No 19

© COMMONWEALTH OF AUSTRALIA 1979

MARCH, 1979

79 07 18 012
UNCLASSIFIED

APPROVED
FOR PUBLIC RELEASE

**THE UNITED STATES NATIONAL
TECHNICAL INFORMATION SERVICE
IS AUTHORISED TO
REPRODUCE AND SELL THIS REPORT**

DEPARTMENT OF DEFENCE
DEFENCE SCIENCE AND TECHNOLOGY ORGANISATION
AERONAUTICAL RESEARCH LABORATORIES

9
Aerodynamics Technical Memorandum 312

6 THE AERODYNAMICS DIVISION AIRBORNE DATA ACQUISITION
PACKAGE TEST AND CALIBRATION UNIT.

10 P. FERRAROTTO

11 Mar 79

12 50p.

14 ARL/AERO-TM-312
SUMMARY

This unit was constructed specifically for the purpose of testing and calibrating the Aerodynamics Division Airborne Data Acquisition Package. The unit consists of sine wave generators, modulators and miscellaneous circuits which generate test signal outputs for checking the data acquisition system.

D D C
RECEIVED
JUL 19 1979
RECEIVED
D

POSTAL ADDRESS: Chief Superintendent, Aeronautical Research Laboratories,
Box 4331, P.O., Melbourne, Victoria, 3001, Australia.

✓
008 650

CONTENTS

PAGE NO.

1.	INTRODUCTION	1
2.	OPERATION	1
3.	POWER SUPPLIES	2
4.	MECHANICAL LAYOUT	2
5.	CONCLUSION	3

REFERENCES

TABLES 1-2

FIGURES 1-9

DOCUMENT CONTROL DATA

DISTRIBUTION

Accession For	
NTIS G.A.I.	<input checked="" type="checkbox"/>
DDC TAB	
Unannounced Justification	
By _____	
Distribution/ _____	
Availability Codes	
Dist.	Avail and/or special
A	

1. INTRODUCTION

The unit described in this memorandum was designed and built in conjunction with the Aerodynamics Division Airborne Data Acquisition Package (ADADAP). It provides a means by which the ADADAP can be checked for correct operation. The output signals of the unit simulate the various analogue signals which would normally be derived from transducers on board an instrumented aircraft.

A brief description of the operation of the unit and circuit details are included in the following sections of this memorandum.

2. OPERATION

The ADADAP (1) was designed to record analogue signals from transducers, some of which give a d.c. output, while others give a modulated 400 Hz output. This unit supplies all the necessary signals to simulate the output of these transducers and also provides a positive and negative d.c. reference voltage for calibration purposes; in particular, the calibration of the conditioning amplifiers in the ADADAP for gain, offset, drift and reliability of operation.

A block diagram of the unit is shown in Fig. (1). The sine waves at preset frequencies are generated using Wein Bridge oscillators (2). These sinusoidal outputs simulate the varying outputs of direct coupled transducers. The circuitry employed to produce these signals is shown in Fig. (2). One of the Wein Bridge circuits produces a 400 Hz sine wave which was originally used as a carrier and was modulated by each of the other three frequency sinusoids. However, in the aircraft for which the ADADAP was designed, the 400 Hz 115 volts is generated using a single phase rotary inverter. Therefore in this unit the 400 Hz carrier is generated with an aircraft single phase rotary inverter rather than a solid state oscillator so as to more nearly simulate the actual carrier conditions of an aircraft system.

Each of the three sinusoidal signals mentioned above modulate the 400 Hz carrier and the three resulting signals serve to simulate the signals from Linear Variometers. The circuitry used to provide this function is shown in Fig. (3). A built-in Linear Variometer (LV) provides the facility for modulating the 400 Hz carrier other than at the three fixed frequencies. Also the LV output is more representative of the actual signal from a similar transducer installed in an aircraft.

A Three Wire Synchro. Transmitter powered by the rotary inverter produces yet another type of signal.

Table 1 lists the signals available from the unit and these are given a type number (1 through 11) for the purpose of identification in Table 2.

Table 2 shows the connections of the signals to each of the five output connectors. It is seen from Fig. 1 that two different signals can be placed on some pins of the output plugs.

Fig. (1) shows that signal types, 1, 2, 3, 4, 5, 6, 9 and 11 can be switched to the distribution board. Signal type 7 is permanently available on the distribution board. Signals type 8 and 10 bypass the distribution board and connect to allocated pins on the output connectors.

Signal type 9 is a bipolar reference voltage which is available at the distribution board for the purpose of calibrating the direct coupled amplifiers in the ADADAP. Fig. (4) shows the voltage reference circuit which uses two temperature stabilized LM399 integrated circuits to provide a positive and a negative reference voltage.

A few seconds after switch-on, the three sine waves (types 1, 2 and 3) are available at the distribution board and consequently on the pins of the output plugs as shown on Table 2. The delay is for the Wein Bridge Oscillators (which provide the sine waves) to attain full output amplitude. If signals type 4, 5, 6, 7 and 11 are required, it is necessary to turn on the rotary inverter using the front panel switch provided. For signal type 10, an external signal needs to be fed into the two connectors provided on the front panel. Specifically, for the ADADAP this external signal is a 70 Hz sine wave of 20 volts peak-to-peak amplitude.

3. POWER SUPPLIES

Fig. (5) shows a standard ± 5 volt supply printed circuit board used to power the three modulator circuits, sine wave generators and the d.c. voltage reference board. An additional +28 volt supply Fig. (6) powers the rotary inverter. The internal starting current of the rotary inverter is approximately 1.2 amps. with a running current of 0.6 amps. The +28 volt supply contains large capacitors to supply the initial surge in current without a significant drop in voltage at the input to the rotary inverter.

4. MECHANICAL LAYOUT

A standard 483 X 177 X 418 mm instrument case houses the printed circuit boards, transformers etc. that make up the unit. All circuits are on standard M8 size printed circuit cards and slide into 56 pin Cannon printed circuit board edge connectors along guide rails. Printed circuit boards are easily accessible via the removable section of the back panel.

Fig. (7) shows the general mechanical layout of the unit and Fig. (8) shows the inter-wiring of the printed circuit board edge connectors. The layout of the front panel is shown in Fig. (9).

5. CONCLUSIONS

This unit has proved to be valuable for simulating the transducers outputs which are required for checking the ADADAP for correct operation and for calibrating the conditioning amplifiers for gain, offset and drift.

The distribution board inside the unit gives greater flexibility, in that most of the outputs to the front panel plugs can be changed by simply unsoldering and reconnecting those outputs to the required signals on the distribution board.

REFERENCES

- (1) The Aerodynamics Division Airborne Data Acquisition Package,
A.J. Farrell, Aero. Note (To be published).
- (2) Simple Low Distortion Wein Bridge Oscillator,
R.N. Caffin, C.S.I.R.O. Division of Textile Physics, Electronic
Engineering, October 1975, pp. 13-15.
- (3) Synchronous and Non-Synchronous Rectification with Op. Amp.,
W.J. Macken, Regional Technical College Dundalk, Eire,
Electronic Engineering March 1973, pp. 18-19.

TABLE 1

SIGNAL	TYPE NO.
1.6 Hz sine	1
3.0 Hz sine	2
5.8 Hz sine	3
1.6 Hz Modulated 400 Hz	4
3.0 Hz Modulated 400 Hz	5
5.8 Hz Modulated 400 Hz	6
Three Wire Synchro.	7
Temperature	8
D.C. Reference	9
Tachometer	10
Linear Variometer	11

SIGNAL OUTPUTS AVAILABLE FROM THE TEST AND
CALIBRATION UNIT.

TABLE 2

CHASSIS MOUNTING PLUG 1 TYPE KPT 00A14 19P		CHASSIS MOUNTING PLUG 2 TYPE KPT 00A14 19P		CHASSIS MOUNTING PLUG 3 TYPE KPT 00A14 19P		CHASSIS MOUNTING PLUG 4 TYPE KPT 00A14 19P		CHASSIS MOUNTING PLUG 5 TYPE KPT 00A14 19P	
PIN	SIGNAL TYPE	PIN	SIGNAL TYPE	PIN	SIGNAL TYPE	PIN	SIGNAL TYPE	PIN	SIGNAL TYPE
A	1 & 9*	A	1 & 9 Δ	A	11 & 6	A	11 & 6	A	7
B	GND	B	GND	B	GND	B	GND	B	7
C	1 & 9*	C	2 & 9.	C	11 & 4	C	11 & 5	C	GND
D	GND	D	GND	D	GND	D	GND	D	7
E	2 & 9*	E	3 & 9.	E	11 & 4	E	11 & 4	E	7
F	GND	F	GND	F	GND	F	GND	F	GND
G	2 & 9*	G	3 & 9.	G	11 & 4	G	400 Hz (From Rot. Inverter)	G	10
H	GND	H	GND	H	GND	H	GND	H	GND (TACHO)
J	1 & 9*	J	1 & 9 Δ	J	11 & 4	J	N/C	J	N/C
K	GND	K	GND	K	GND	K	N/C	K	N/C
L	1 & 9*	L	1 & 9 Δ	L	11 & 4	L	N/C	L	N/C
M	GND	M	GND	M	GND	M	N/C	M	N/C
N	8	N	2 & 9*	N	5	N	N/C	N	N/C
P	8	P	GND	P	GND	P	N/C	P	N/C
R	1 & 9*	R	3 & 9*	R	11	R	N/C	R	N/C
S	GND	S	GND	S	GND	S	N/C	S	N/C
T	1 & 9 Δ	T	3 & 9*	T	11	T	N/C	T	N/C
U	GND	U	GND	U	N/C	U	N/C	U	N/C
V	N/C	V	N/C	V	N/C	V	N/C	V	N/C

For * Value of d.c. voltage is ± 3.5 volts
 Δ " " " " ± 0.5 volts
. " " " " ± 0.6 volts

TEST AND CALIBRATION UNIT OUTPUT CONNECTOR
PIN ALLOCATIONS.

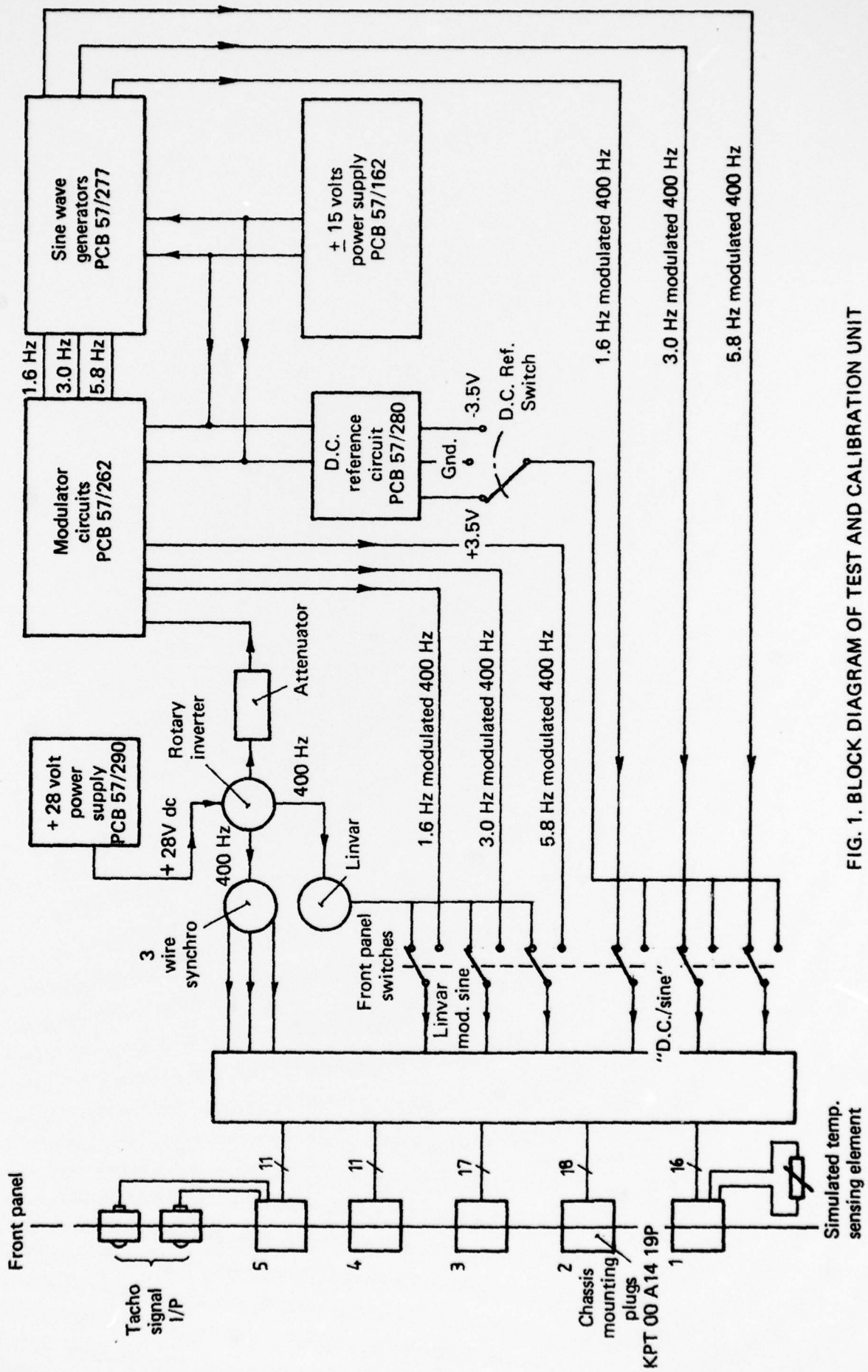
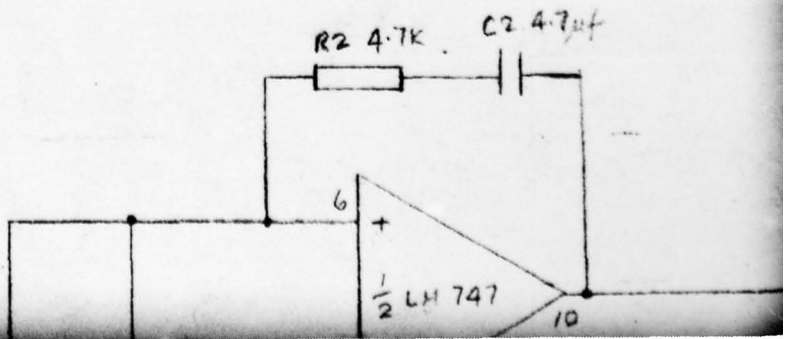
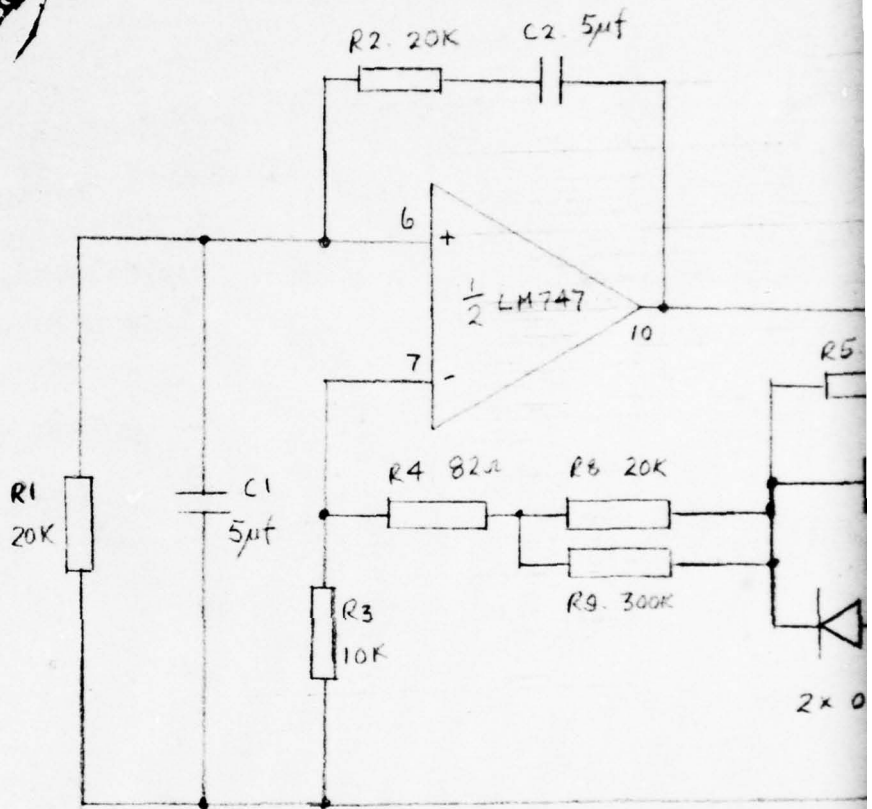
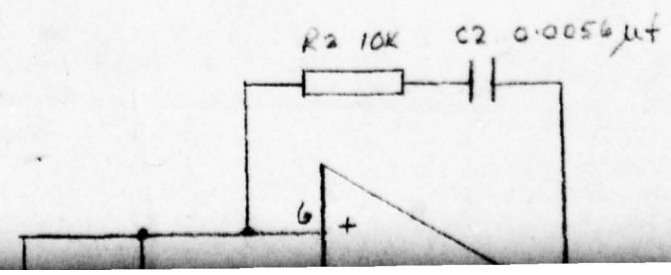
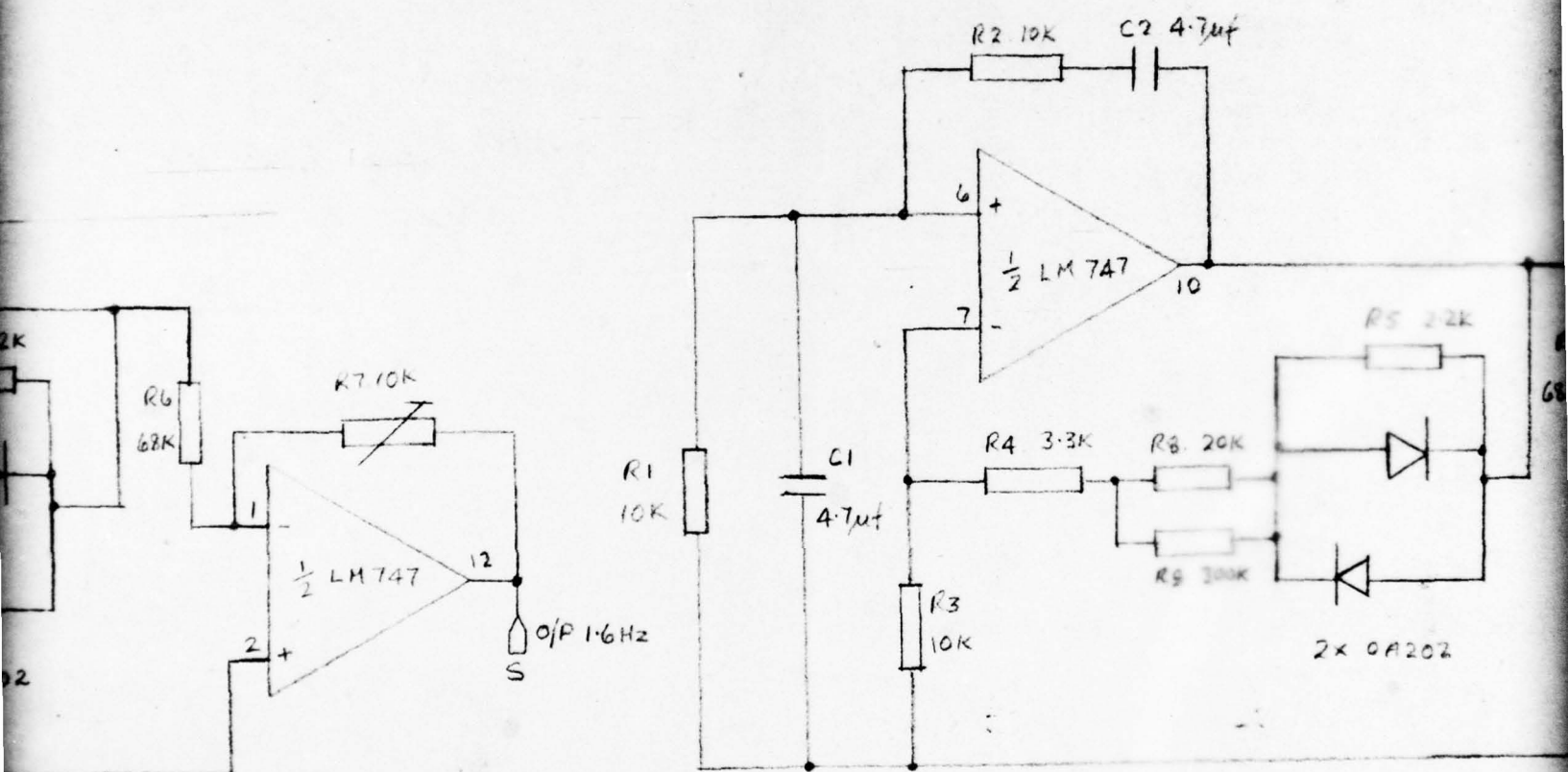

FIG. 1. BLOCK DIAGRAM OF TEST AND CALIBRATION UNIT

THIS PAGE IS BEST QUALITY PRACTITIONER
FROM COPY PUBLISHED TO DDG





2.

3

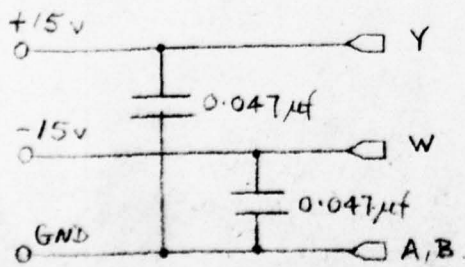
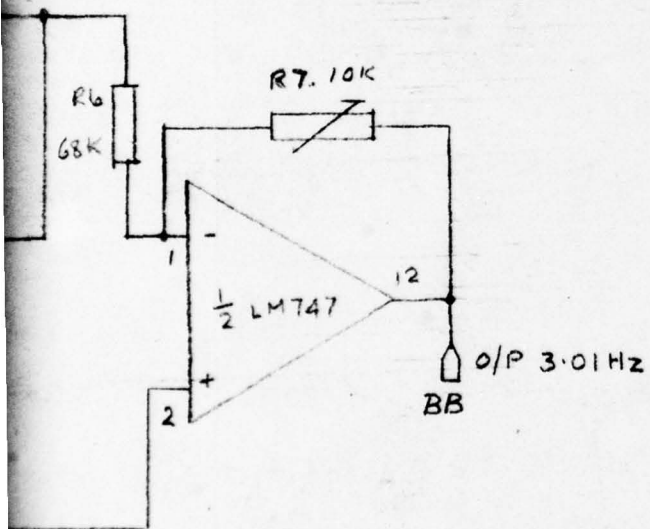

FIG. 21

REVISION		App.	
11.1.77			
12.1.77			
12.1.77			
12.1.77			
COMMONWEALTH OF AUSTRALIA DEPARTMENT OF SUPPLY AERONAUTICAL RESEARCH LABORATORIES		SCALE	DRG. No.

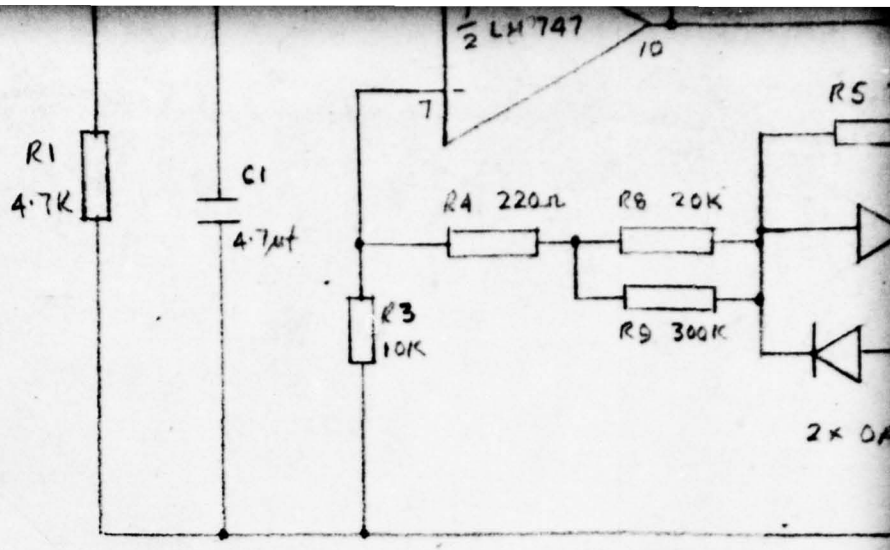
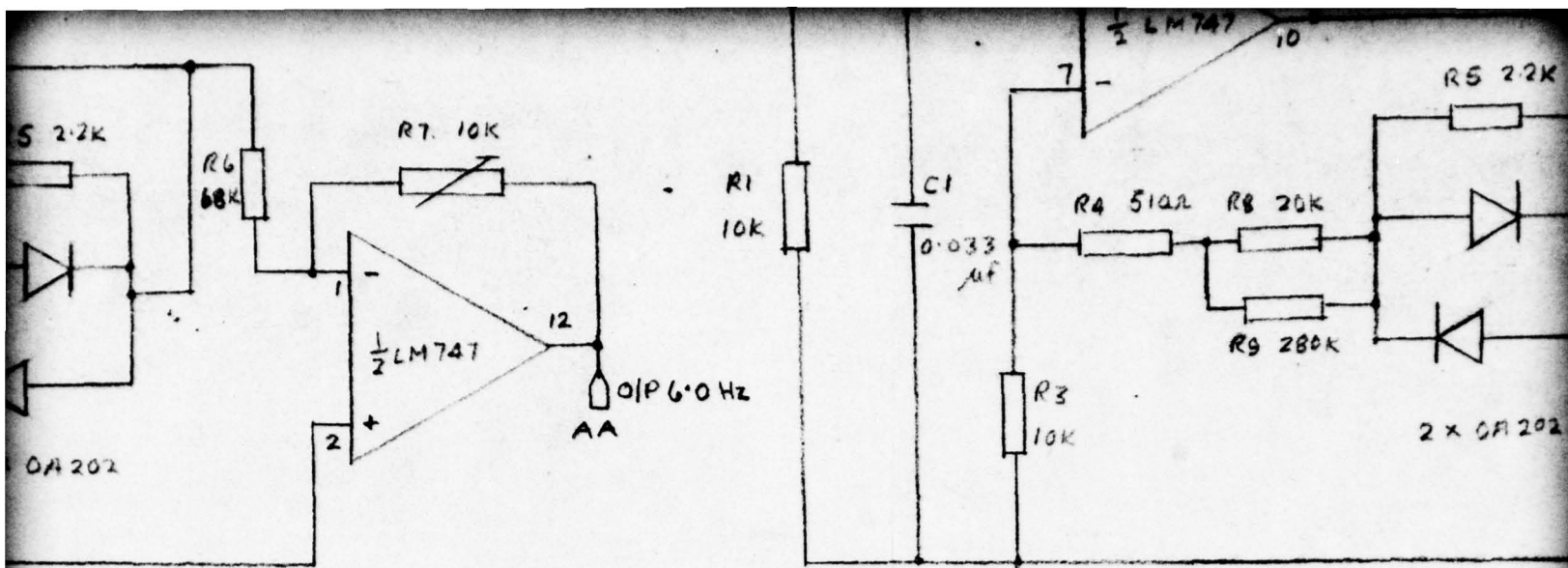

FIG 2 W

4



BOARD

BOARD

WEIN BRIDGE OSCILLATORS

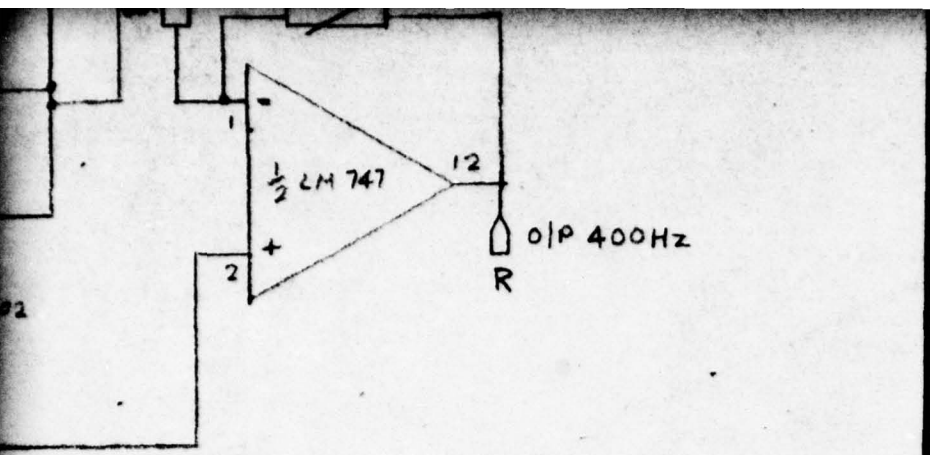

BOARD NAME - WEIN BRIDGE OSCILLATOR

BOARD IDENTIFICATION - 57-277

6

No	DATE	APP

REVISION

TOLERANCES
ALL DIMEN IN

SCALE
TITLE: BALANCED AMPLITUDE
AERONAUTICAL
DIVISION
APPROVA

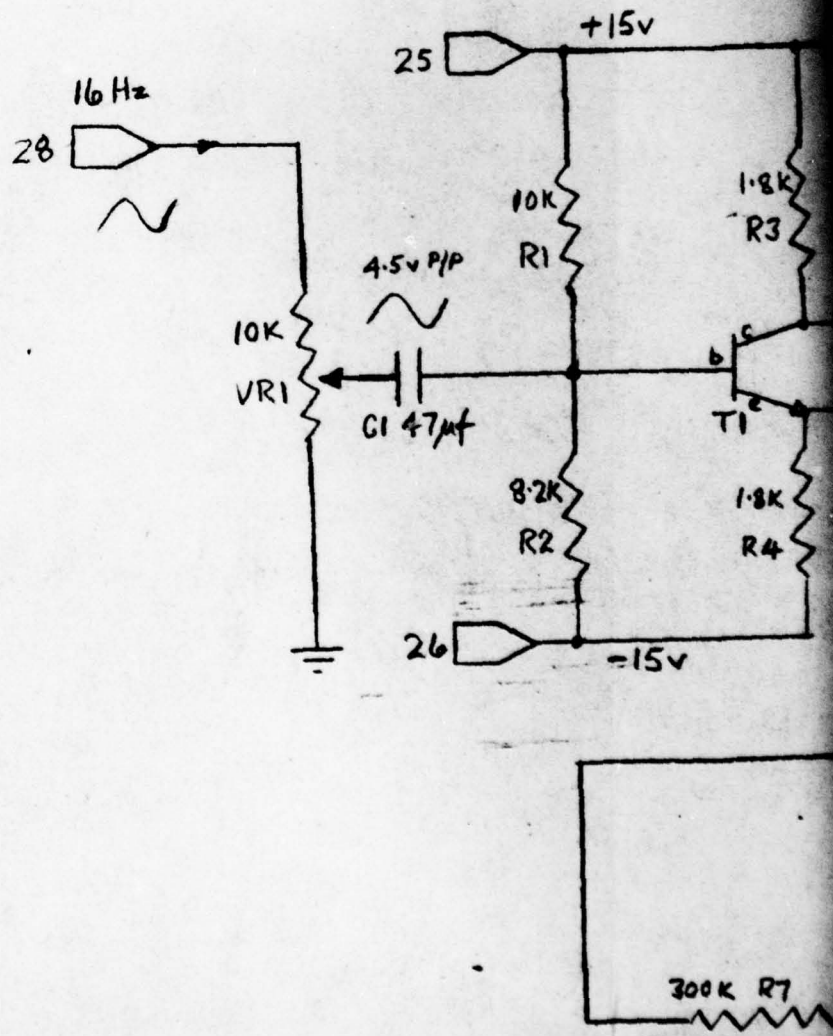

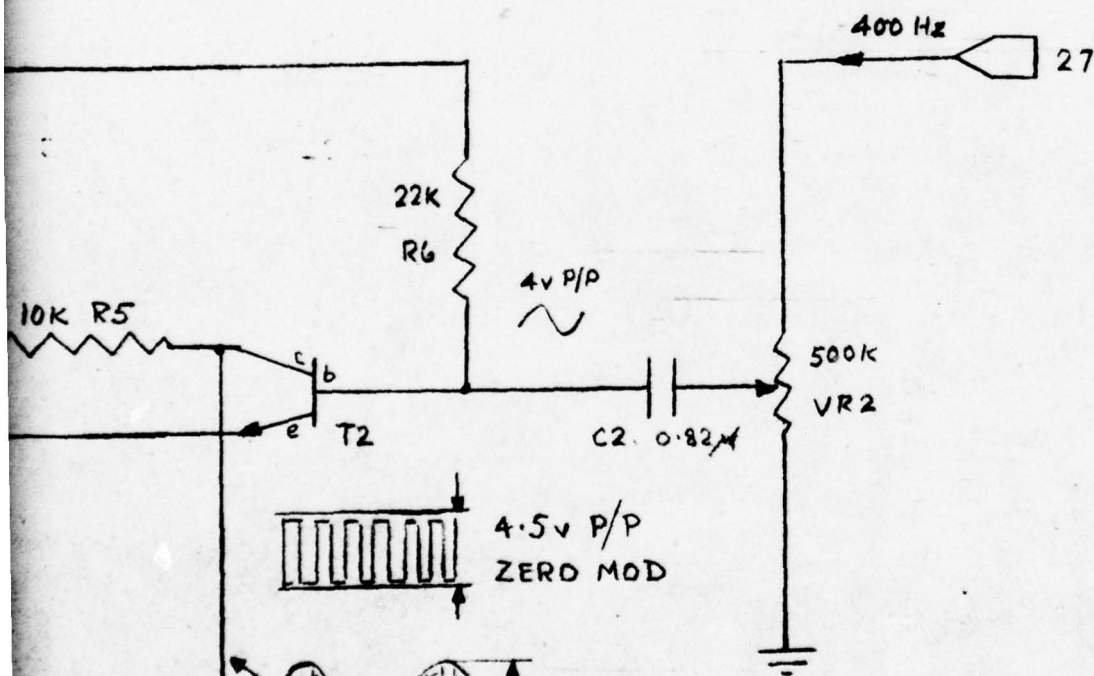

FILTER ($f_c \approx 500$ Hz)

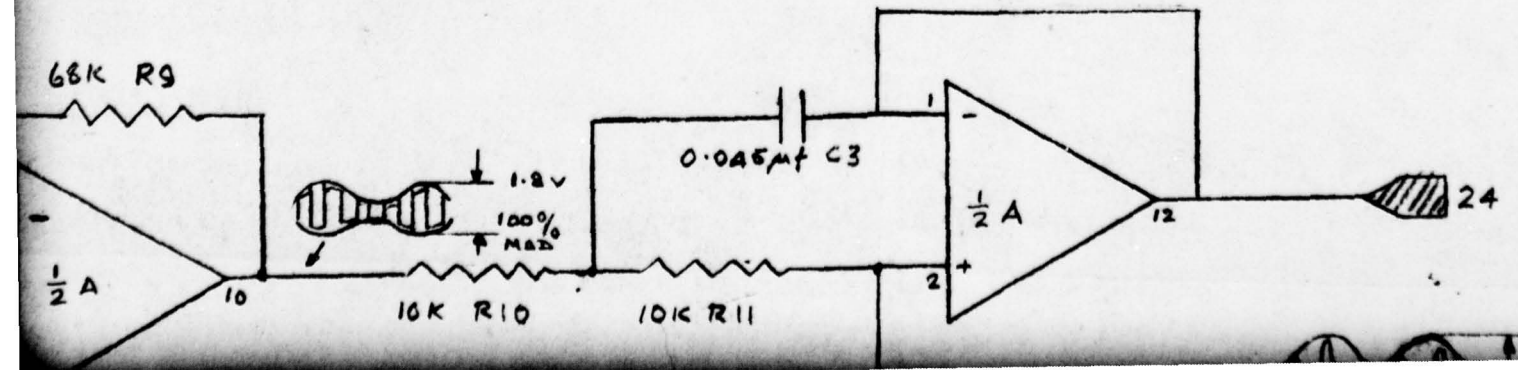

3

THIRD ANGLE PROJECTION

DO NOT SCALE



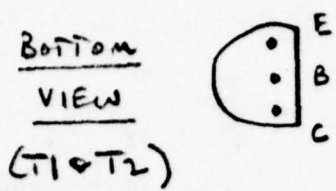
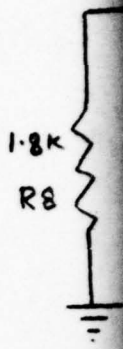
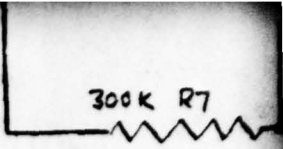

	PACKAGE IDENTIFICATION	SUPPLY PIN CONN	
		+15V	-15V
A	LM 747	9, 13	4
T1, T2	AY 1103	-	-

BOARD SIZE - M8

AERONAUTICAL RESEARCH LABORATORIES - AUSTRALIA	
DIVISION	REC'D
APPROVAL	HRZ
DRAWN	S.H.C.
CHECKED	HRZ
APPROVED	HRZ
10/10/74	GEN. ARRGT.
14/3/77	PARTS LIST
1/3/77	PL
AMPLITUDE MODULATOR 57-262	
DRG. No.	
REVISION No.	
A2	

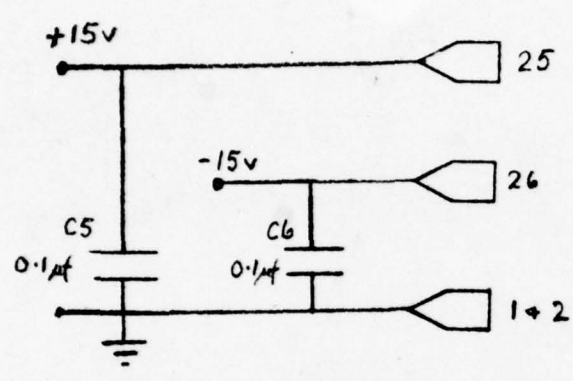
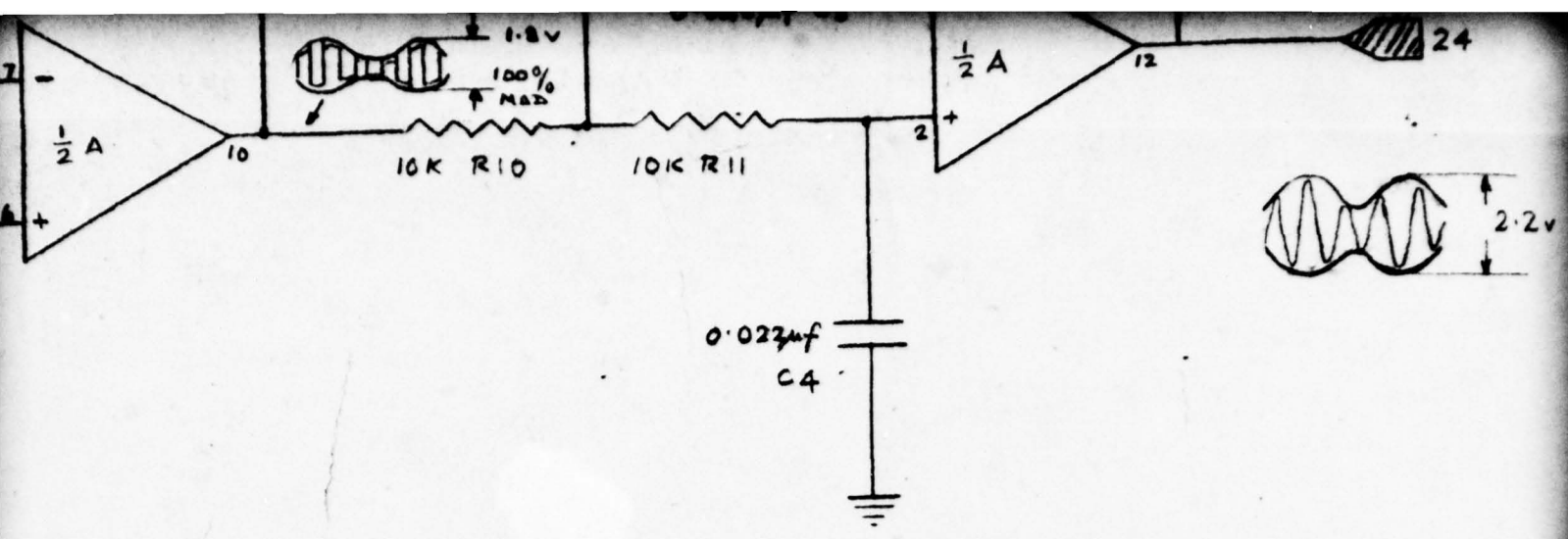

BOARD NAME - BA
 BOARD IDENTIFICAT

FIG. 3 MODULATORS

00% MOD

ANCED AMPLITUDE MODULATOR

DN - 57-262

6

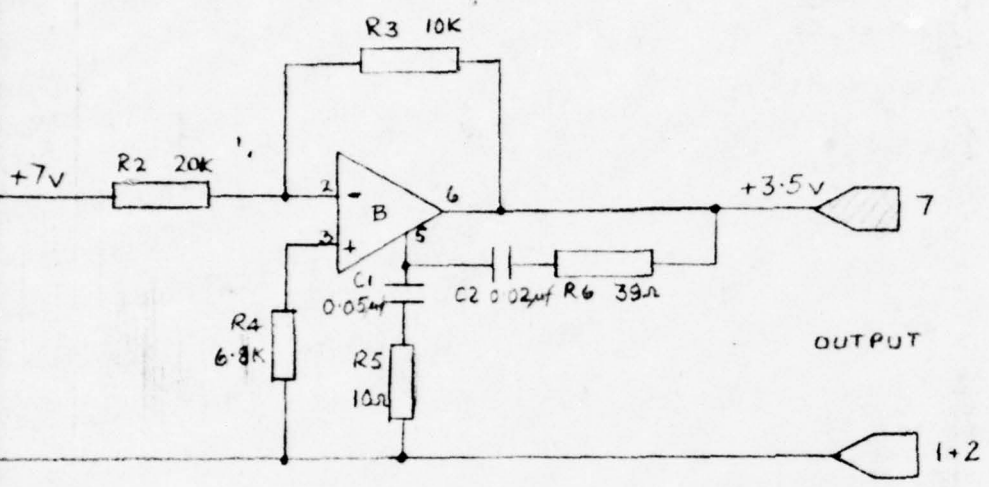

OUTPUT

1+2

POSITIVE REFERENCE

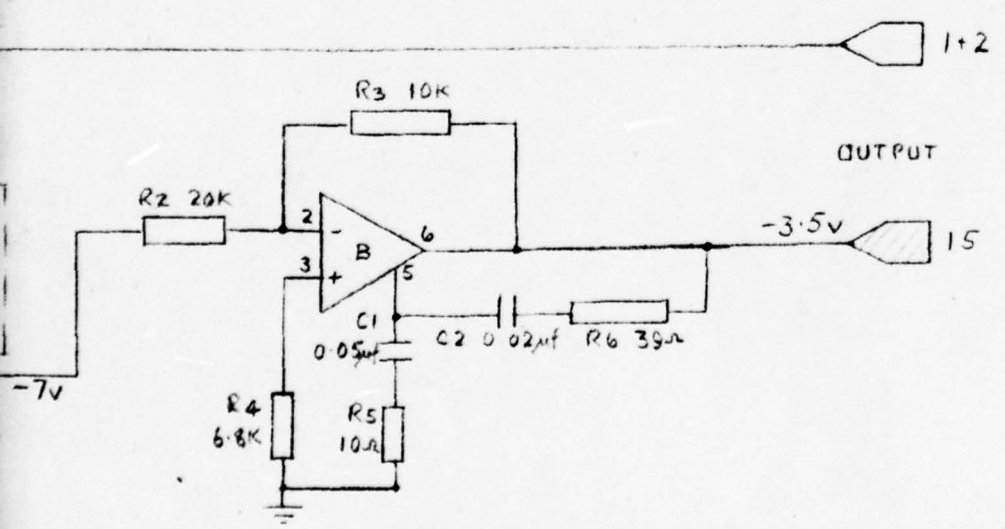

OUTPUT

1+2

NEGATIVE REFERENCE

R8 20K

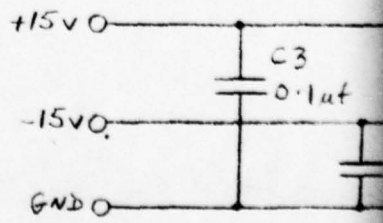

THIRD ANGLE PROJECTION
DO NOT SCALE

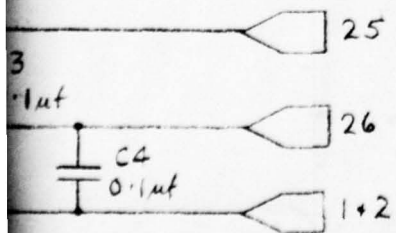



400 Hz
INPUT



FIG

	PACKAGE IDENTIFICATION	SUPPLY PIN CONN	
		+15V	-15V
A	LM399		
B	LM725	7	4
C	LM741	7	4

BOARD SIZE M8

DIVISION	APPROVAL	DRAWN	CHECKED	SIC	30/10/76	GEN. ARRG'T.	
	APPROVED				4.11.76	PARTS LIST	PL
AUTICAL RESEARCH LABORATORIES - AUSTRALIA				DRG. No.			
57-280				REVISION No.			
				A2			

7

GND

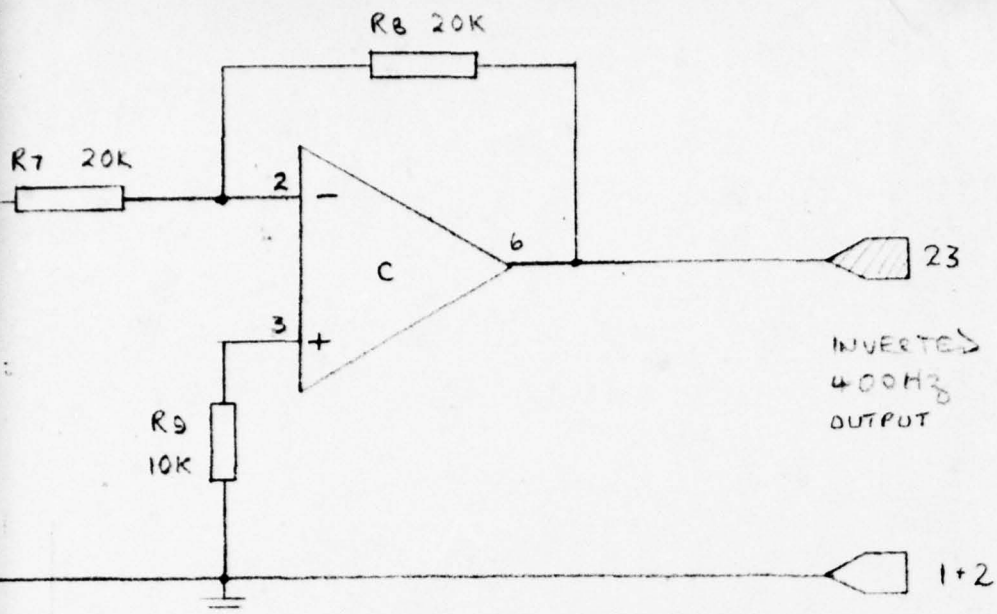

CONDITIONING AMPLIFIER

G.4 D.C. REFERENCE CIRCUIT

U-1A/P 1+2

BOARD NAME - VOLTAGE REF & CON AMP

BOARD IDENTIFICATION - 57-280

51

6

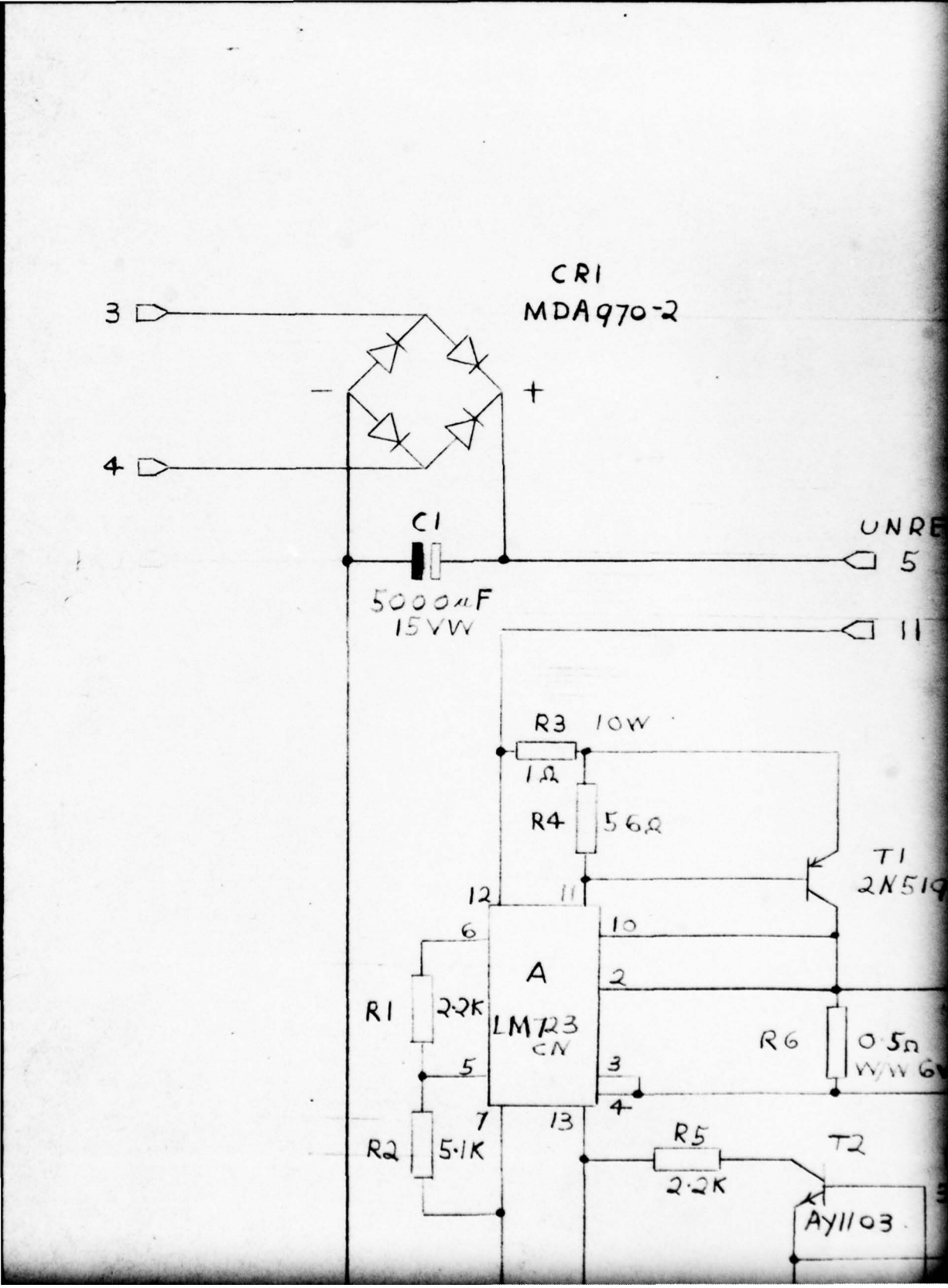

NREG.
5
11

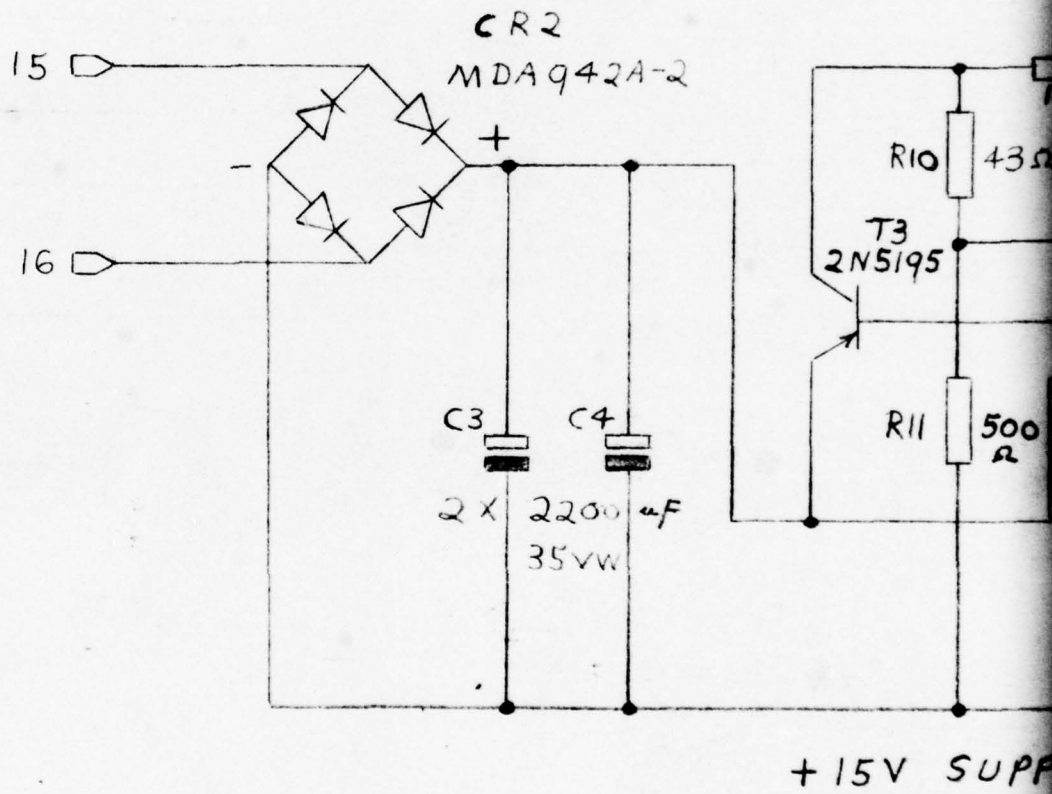

T1
2N5195

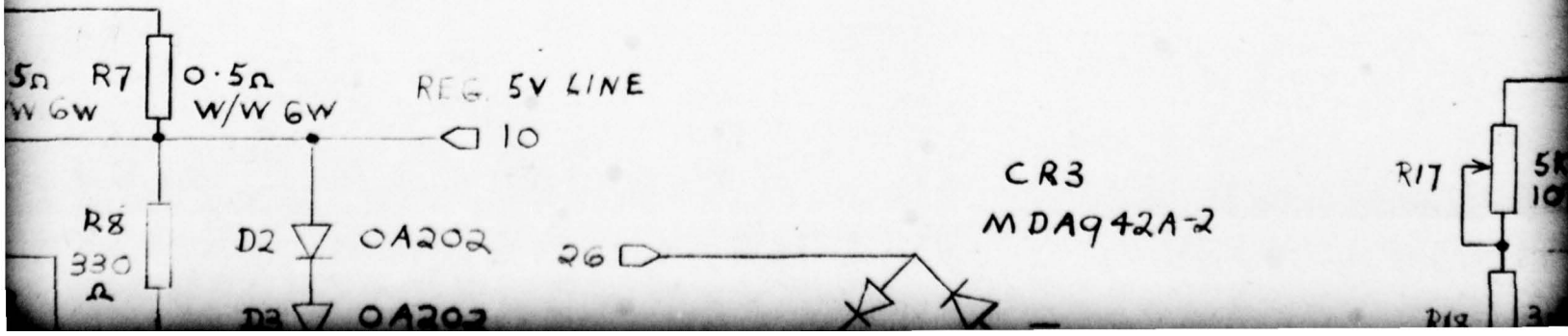

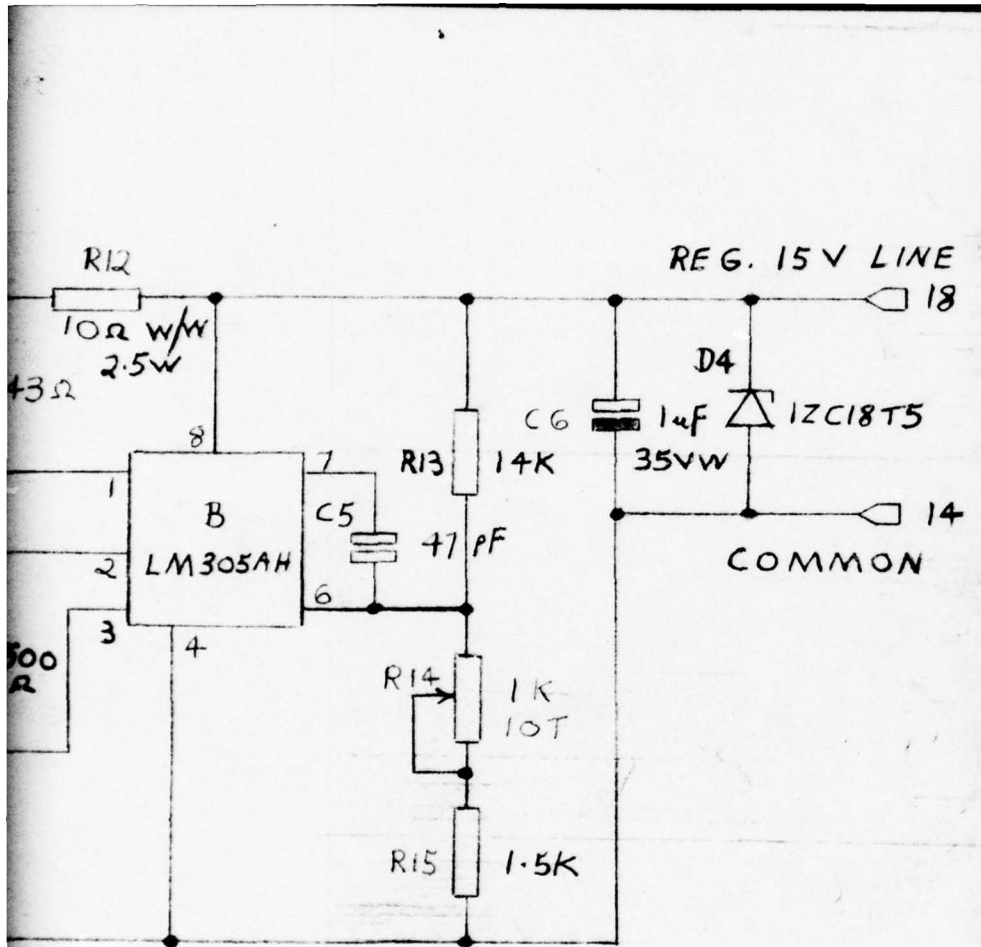

APPLY

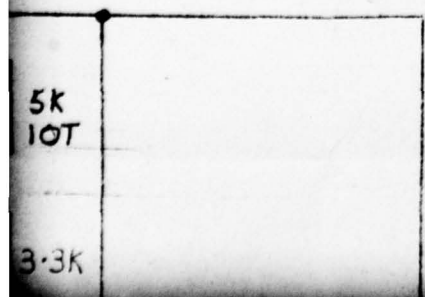

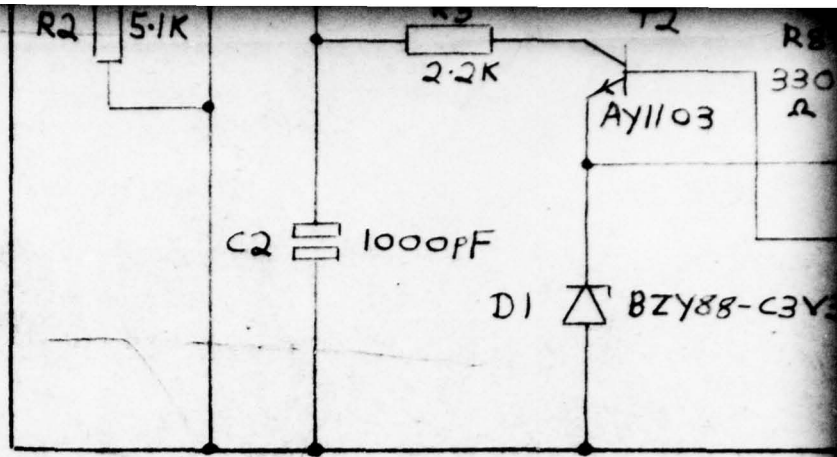

+5V 2A SUPPLY

~~+5 VOLT 2 AMP & DUAL 15 VOLT~~
REGULATED SUPPLIES

PRINTED CIRCUIT BOARD
IDENT No. 57-162

P		DRAWN		RJA		2-1-73		REVISION		App	
		CHECKED									
		APPROVED									
		PASSED									
				COMMONWEALTH OF AUSTRALIA							
				DEPARTMENT OF SUPPLY							
				AERONAUTICAL RESEARCH LABORATORIES							
				SCALE							
				DRG. No.				SK17270			

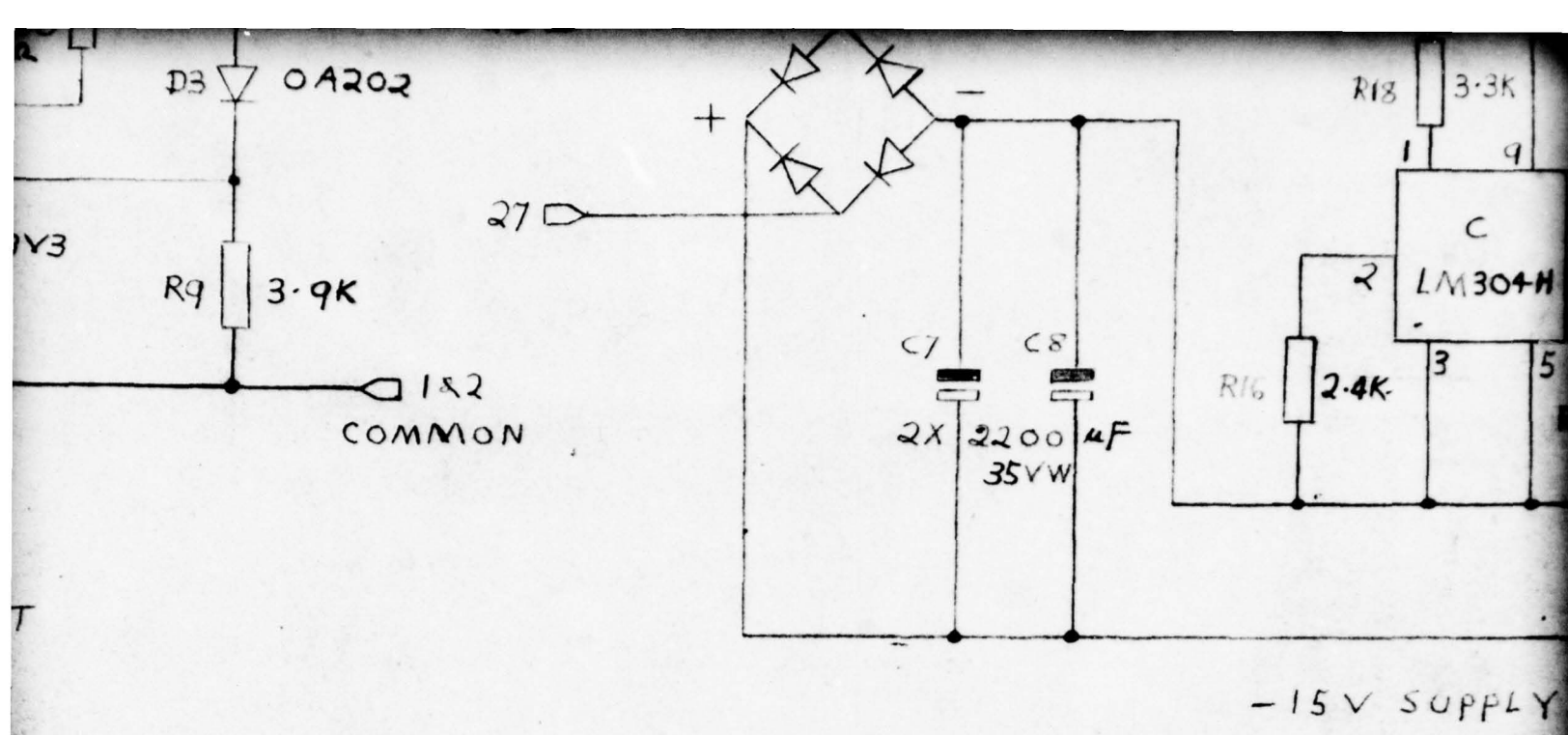

5

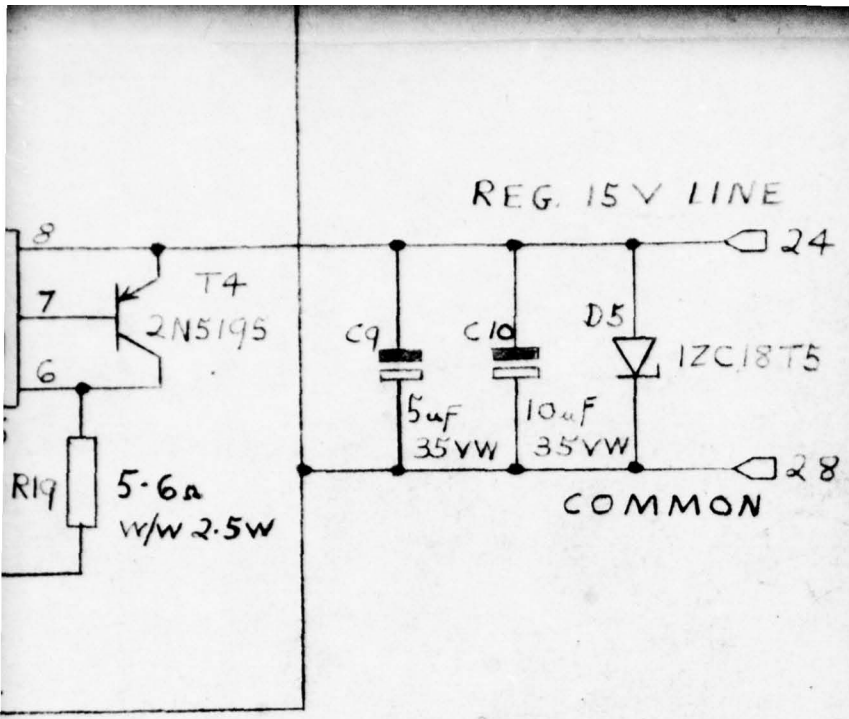

6

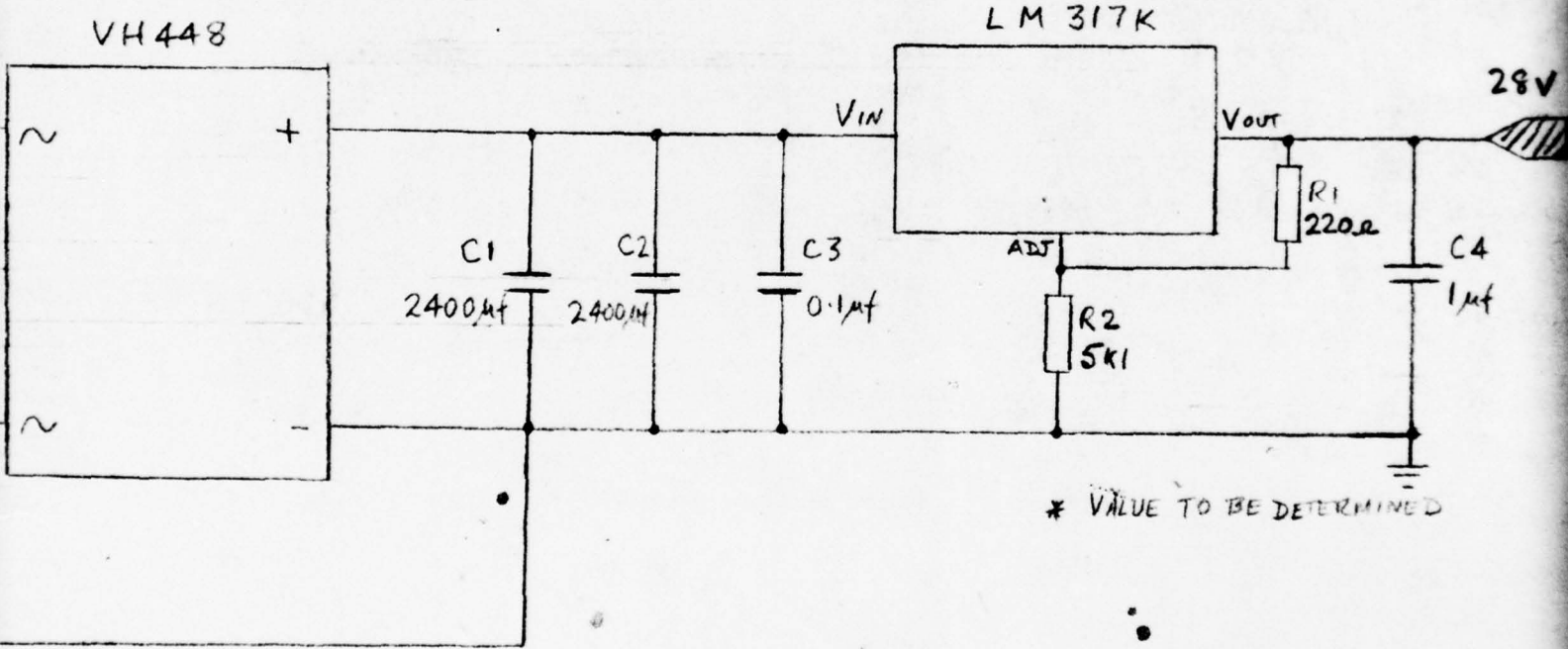

THIRD ANGLE PROJECTION

DO NOT SCALE

4V

 5

DIVISION	REC'D	DRAWN	SMP	3.5.76	GEN. ARRGT.	
APPROVAL	RS	CHECKED	RS	9.3.76	PARTS LIST	PL
		APPROVED	RS	10.3.76		
AUTICAL RESEARCH LABORATORIES - AUSTRALIA						
POWER SUPPLY 57-290				DRG. No.	REVISION No.	A.2

4

BOARD NAME

BOARD ID

FIG. 6 + 28 VOLT SUPPLY



5

NAME - REGULATED 28V POWER SUPPLY

IDENTIFICATION - 57-290

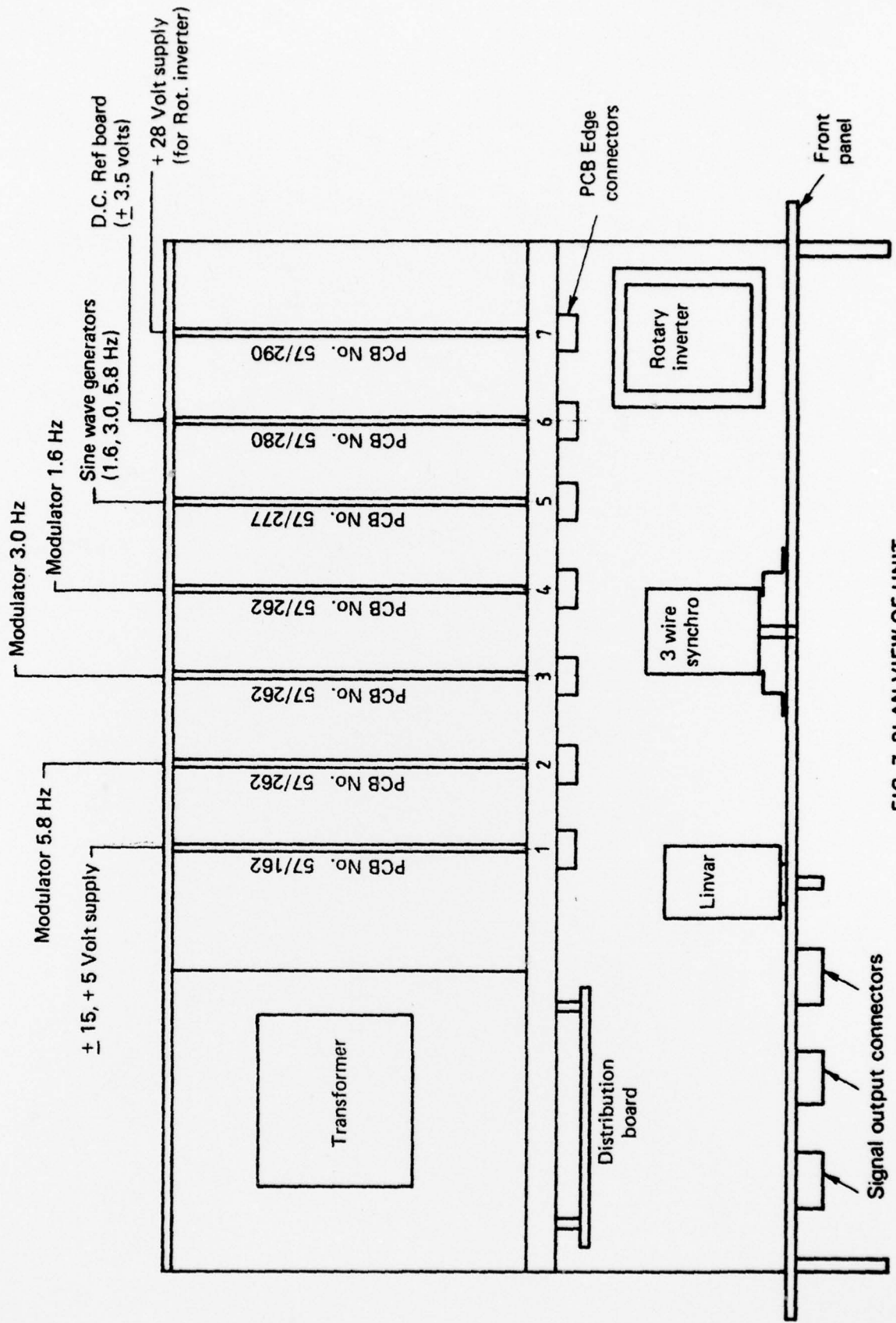
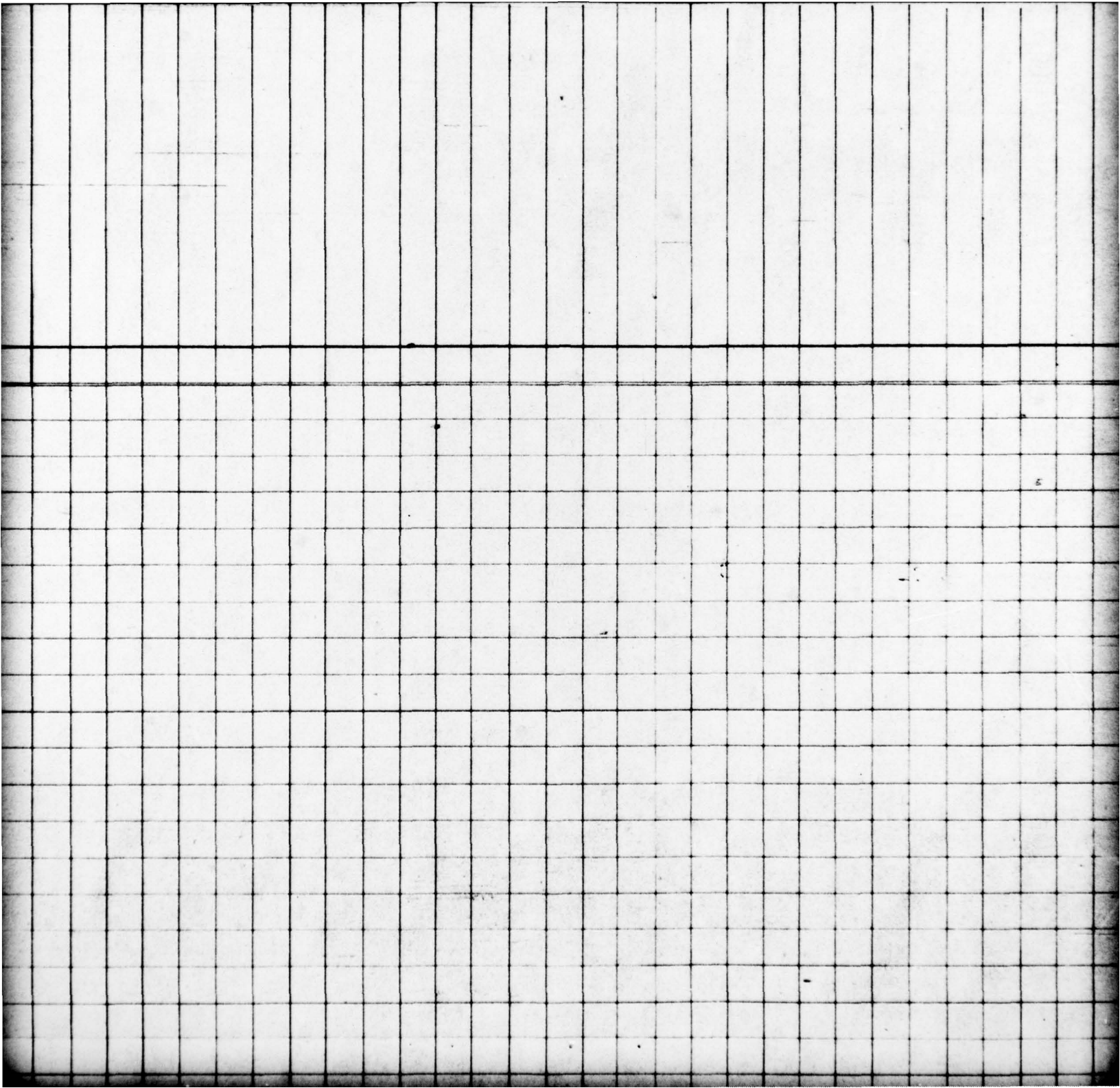

FIG. 7. PLAN VIEW OF UNIT

CIRCUIT PURPOSE	CONNECTOR IDENT.						
	+5, ±15 KWT SUPPLY 57/162	BALANCED AMPLITUDE MOD. 57/262	BALANCED AMPLITUDE MOD. 57/262	BALANCED AMPLITUDE MOD. 57/262	SINE WAVE GENERATOR 57/277	DC REFERENCE BOARD 57/280	+28V POWER SUPPLY 57/290
CONNECTOR IDENT. NO	1	2	3	4	5	6	7
GND	1	1	1	1	A	1	1
"	2	2	2	2	B	2	2
A.C. (9V RMS)	3						
A.C. (9V RMS)	4						
UNREG. D.C.	5/11						
+5 Volt (MODS)	10						
COMMON (+15V)	14						
A.C. (12V RMS)	15						
A.C. (12V RMS)	16						
+15V	18	25	25	25	Y	25	
-15V	24	26	26	26	W	26	
A.C. (12V RMS)	26						
A.C. (12V RMS)	27						
COMMON (-15V)	28						
400 Hz ROT. INVERTER		27	27	27			
1.6 Hz SINE WAVE					28	T	
30 Hz			28			BB	
58 Hz		28				AA	
400 Hz MOD 1.6 Hz (COP)				28			



A.

DRAWN	PK	COMMONWEALTH OF AUSTRALIA DEPARTMENT OF SUPPLY AERONAUTICAL RESEARCH LABORATORIES
CHECKED	13/10/77	
APPROVED		
SCALE		DRG No

REVISION	App
----------	-----

1.6 Hz SINE WAVE	28	T
3.0 Hz	28	BB
5.8 Hz	28	AA
400 Hz MOD 1.6 Hz (O/P)	24	
" MOD 3.0 Hz (O/P)	24	
" MOD 5.8 Hz (O/P)	24	
+ 28 VOLTS		5
AC		3
AC		4
- 3.5 V REFERENCE (O/P)		15
+ 3.5 V REFERENCE (O/P)		7

FIG. 8 LOOM DI

4

DIAGRAM FOR TEST AND CALIBRATION UNIT

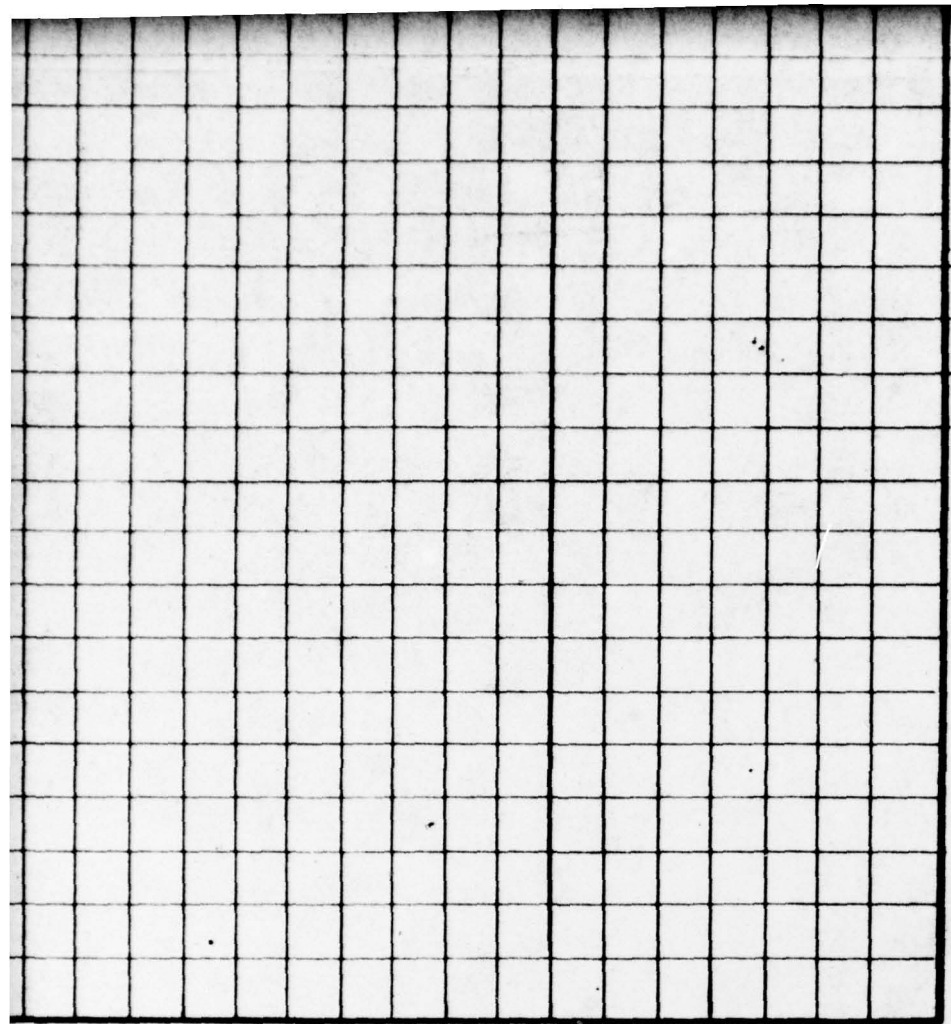

6

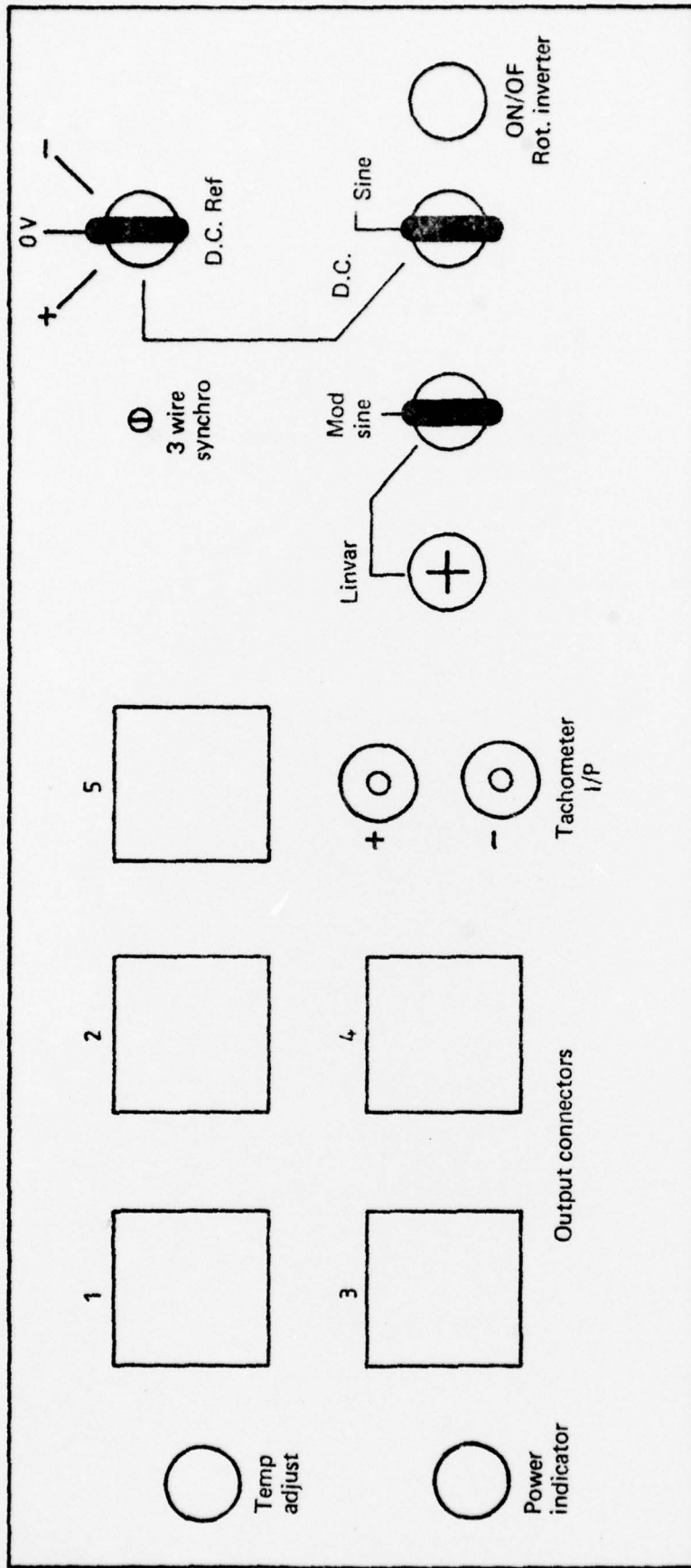

FIG. 9. FRONT PANEL LAYOUT

DOCUMENT CONTROL DATA SHEET

Security classification of this page: UNCLASSIFIED

- | | |
|---|---|
| <p>1. DOCUMENT NUMBERS</p> <p>a. AR Number:
AR-001-601</p> <p>b. Document Series and Number:
Aerodynamics Technical
Memorandum 312</p> <p>c. Report Numbers:
ARL-AERO-TECH-MEMO-312</p> | <p>2. SECURITY CLASSIFICATION</p> <p>a. Complete document:
UNCLASSIFIED</p> <p>b. Title in isolation:
UNCLASSIFIED</p> <p>c. Summary in isolation:
UNCLASSIFIED</p> |
|---|---|
-
3. TITLE:

THE AERODYNAMICS DIVISION AIRBORNE DATA ACQUISITION
PACKAGE TEST AND CALIBRATION UNIT.

- | | |
|---|---|
| <p>4. PERSONAL AUTHOR:</p> <p>P. FERRAROTTO</p> | <p>5. DOCUMENT DATE:
MARCH, 1979</p> <p>6. TYPE OF REPORT AND PERIOD
COVERED:
TECH. MEMO.</p> |
|---|---|
-
- | | |
|--|---|
| <p>7. CORPORATE AUTHOR(S):
Aeronautical Research
Laboratories</p> <p>9. COST CODE:
57 2090</p> | <p>8. REFERENCE NUMBERS</p> <p>a. Task:
NAV 74/04</p> <p>b. Sponsoring Agency:
NAVY</p> |
|--|---|
-
- | | |
|---|---|
| <p>10. IMPRINT:
Aeronautical Research
Laboratories, Melbourne</p> | <p>11. COMPUTER PROGRAM(S):
(Title(s) and Language(s)):</p> |
|---|---|

12. RELEASE LIMITATIONS (of the document):

Approved for Public Release.

12-0. OVERSEAS:	NO		P.R.	1	A	B	C	D	E
-----------------	----	--	------	---	---	---	---	---	---

13. ANNOUNCEMENT LIMITATIONS (of the information on this page):

No Limitation.

- | | |
|---|--|
| <p>14. DESCRIPTORS:</p> <p>Data acquisition. Measuring</p> <p>Calibrating. instruments.</p> <p>Test equipment.</p> <p>Flight tests.</p> | <p>15. COSATI CODES:</p> <p>0102</p> <p>1402</p> |
|---|--|

16. ABSTRACT:

This unit was constructed specifically for the purpose of testing and calibrating the Aerodynamics Division Airborne Data Acquisition Package. The unit consists of sine wave generators, modulators and miscellaneous circuits which generate test signal outputs for checking the data acquisition system.

DISTRIBUTION

COPY NO.

AUSTRALIA

Department of Defence

Central Office

Chief Defence Scientist	1
Deputy Chief Defence Scientist	2
Superintendent, Science and Technology Programs	3
Defence Library	4
Joint Intelligence Organization	5
Assistant Secretary, D.I.S.B.	6-21

Aeronautical Research Laboratories

Chief Superintendent	22
Superintendent - Aerodynamics Division	23
Divisional file - Aerodynamics	24
Author: P. Ferrarotto	25
Instruments Group file	26-30

Materials Research Laboratories

Library	31
---------	----

Defence Research Centre, Salisbury

Library	32
---------	----

SPARES

33-42