

AD-A071 815

LITTLE (ARTHUR D) INC CAMBRIDGE MASS  
SYSTEMS ANALYSIS OF ARCTIC FUELS DISPENSING EQUIPMENT. (U)

F/6 21/4

UNCLASSIFIED

JUN 79 D B ROSENFELD, E A GILBERT  
ADL-80260-18

DAAK70-77-D-0024  
NL

1 of 2  
AD  
A071815

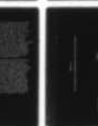
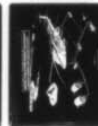

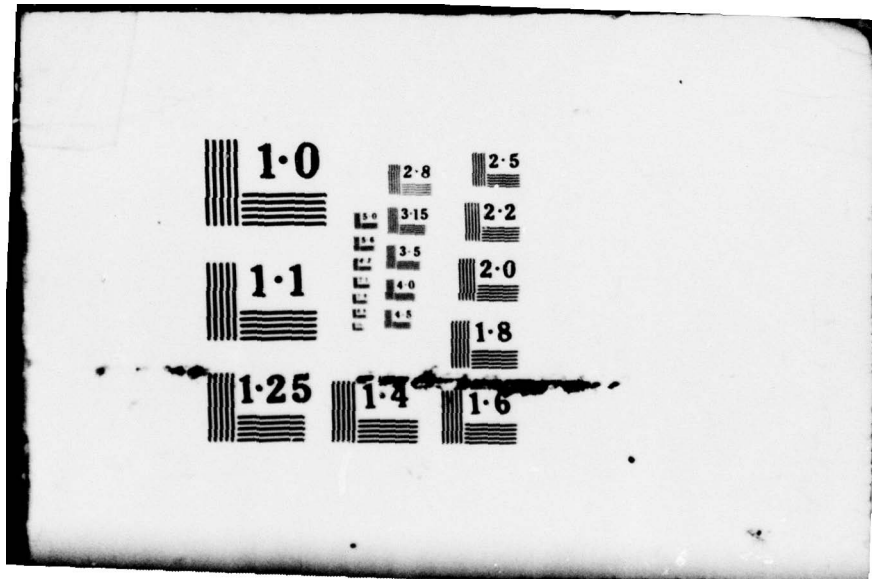

1.0

1.1

1.25

2.8  
3.15  
3.5  
4.0  
4.5

1.4

2.5

2.2

2.0

1.8

1.6

MERADCOM DAAK70-77-D-0024  
Task Order No. 9

**LEVEL II**

5

A071815

# Systems Analysis Of Arctic Fuels Dispensing Equipment

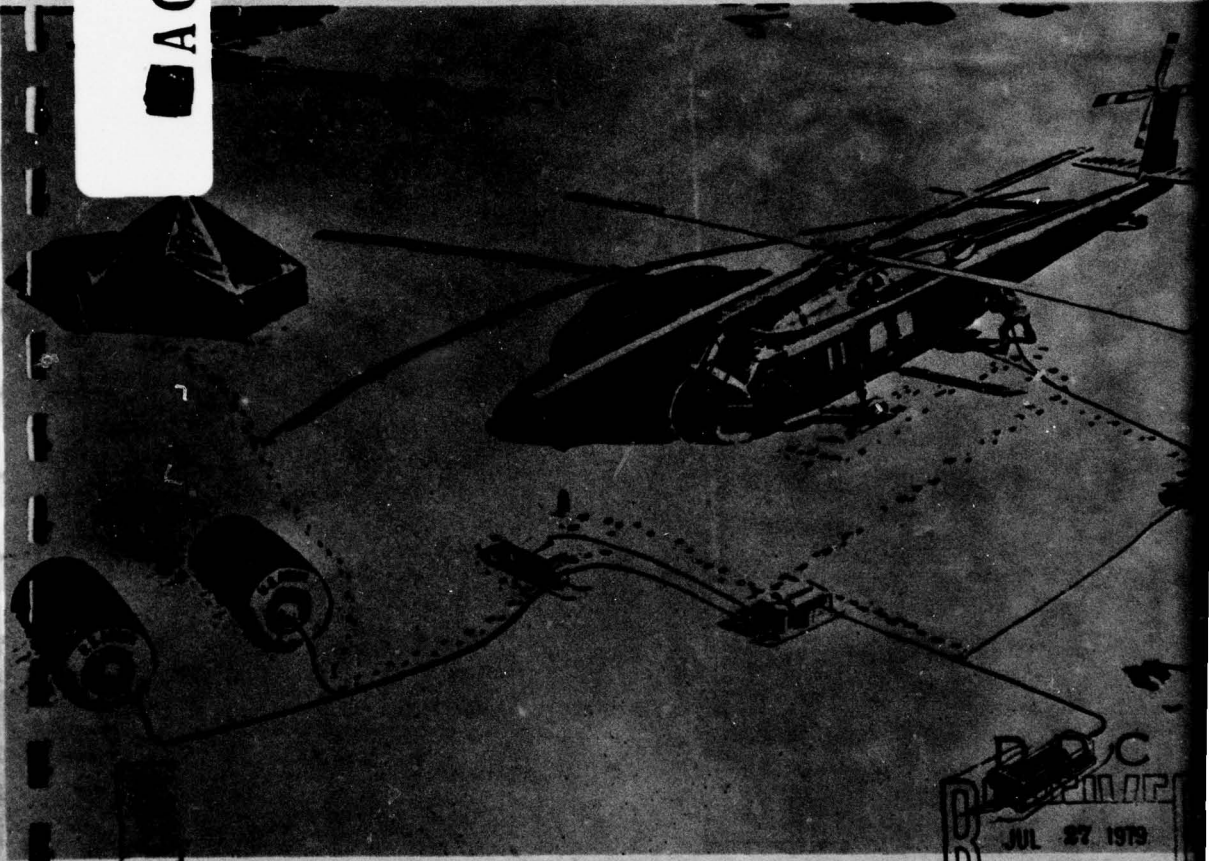

DDC FILE

DDC  
RECEIVED  
JUL 27 1979  
- D -

JUNE 30, 1979

79 07 19 052

Arthur D Little, Inc.

U.S. Army Mobility Equipment Research and Development Command  
Fort Belvoir, Virginia 22060

DISTRIBUTION STATEMENT  
Approved for public release  
Distribution Unlimited

6 SYSTEMS ANALYSIS OF ARCTIC FUELS DISPENSING EQUIPMENT

U.S. Army Mobility Equipment Research and Development Command  
(MERADCOM)

JUNE 30, 1979

11 30 Jun 79

12 1724

14 ADI - 80260-18

9 Final Rpt. 1 Jan - 30 Jun 79

15 DAAK70-77-D-0824

20 Donald B. / Rosenfield,  
Edgar A. / Gilbert, II  
John S. / Howland

Accession For	
NIS GRA&I	<input checked="" type="checkbox"/>
DEC TAB	<input type="checkbox"/>
Unannounced	<input type="checkbox"/>
Justification	
By	
Distribution/	
Availability Codes	
Avail and/or special	
A	

DDC  
RECEIVED  
JUL 27 1979  
REGISTERED  
D

208 850

Arthur D Little Inc

79 07 19 052

Cover Drawing is Courtesy of U.S. Army

DISTRIBUTION STATEMENT A  
Approved for public release;  
Distribution Unlimited

DISCLAIMER

The views and conclusions contained in this document are those of the authors and should not be interpreted as necessarily representing the official policies, either expressed or implied, of the U.S. Army Mobility Equipment Research and Development Command or the U.S. Government.

## FORWARD

This document summarizes the key findings and presents the background materials relevant to the study entitled "Systems Analysis of Arctic Fuels Dispensing Equipment." The report presents a systems analysis approach and evaluation of alternatives considered for arctic fuels dispensing equipment. The report is submitted to the U.S. Army Mobility Equipment Research and Development Command (MERADCOM) at Fort Belvoir, Virginia by Arthur D. Little, Inc., 20 Acorn Park, Cambridge, Massachusetts 02140, and was prepared under Task Order No. 9 of Contract No. DAAK70-77-D-0024. The report was prepared under the guidance of Mr. Leon Medler and Mr. Taylor Jefferson of MERADCOM. Questions of a technical nature should be addressed to Dr. Donald B. Rosenfield, the manager of the study and principal investigator, at (617) 864-5770. Other key contributors included Mr. Irving Aarons, Mr. Edgar A. Gilbert III, Mr. John S. Howland, and Dr. Gordon Raisbeck.

## TABLE OF CONTENTS

	<u>Page</u>
Forward	i
Table of Content	ii-iii
List of Tables	iv
List of Figures	v
Executive Summary	vi-viii
Chapter 1 - Introduction and Background	1
Chapter 2 - Systems Analysis Methodology	8
2.1 General Methodology	8
2.2 Identification of Attributes	10
Chapter 3 - Technical Approaches and Alternatives	14
Chapter 4 - Preliminary State-of-the-Art Research	57
4.1 Introduction	57
4.2 Current Cold Weather Practices and Technology	58
4.3 Gas Turbine Engines for Pump Drives	64
4.4 Solid Propellents and Accumulators	65
Chapter 5 - First Phase Evaluation	68
5.1 Introduction	68
5.2 Preliminary Evaluation of Standard Baseline System	69
5.3 Steps in Evaluation Procedure	72
5.4 Consolidation of Attributes	72
5.5 Decomposition of Alternatives	74
5.6 Scoring Methodology	77
5.7 Scoring Totals, Interpretation, and Candidates for Final Evaluation	89
Chapter 6 - Final State-of-the-Art Research	98
6.1 Introduction	98
6.2 Advanced Batteries	98
6.3 Elastomerics	100

TABLE OF CONTENTS (CONTINUED)

	<u>Page</u>
Chapter 7 - Final Evaluation of Alternatives	112
7.1 Introduction	112
7.2 Steps in Analysis	112
7.3 Performance Rating	121
7.4 Conclusions	121
Chapter 8 - Recommendations of Future Development and Testing Requirements	127
Appendix 1 - Operational Requirements for Acceptable AFDE Systems	1-3
Appendix 2 - Sources of Information and References	4-9
Appendix 3 - Back Up Material for Pump Drives	10-23
Appendix 4 - Description of Selected Elastomeric Classes	24-28

## LIST OF TABLES

	<u>Page</u>
Table 5-1	
Scoring for FSSP Alternatives	78
Scoring for FARE Alternatives	79
Scoring for Pump Alternatives	80
Scoring for Pump Drive Alternatives	81
Scoring for Hosing Alternatives	82
Scoring for Tank Alternatives	83
Table 5-2 - Scoring Table	87
Table 5-3 - AFSSP Scoring	90
Table 5-4 - AFARE Scoring	91
Table 5-5	92
Pump Scoring	
Drive Scoring	
Hosing Scoring	
Tank Scoring	
Table 7-1 - Baseline System Costs	115-116
Table 7-2 - Approximate Costs of Components (Not Including Drive) For Systems Other Than Baseline	117
Table 7-3 - Trade-Off Table (FARE)	119
Table 7-4 - Trade-Off Table (FSSP)	120
Table 7-5 - Estimated Size and Weight of Alternative Systems	122
Table 7-6 - Scoresheet for Performance Attributes	123
Table 7-7 - Combined Performance Ratings Using Various Weighting Schemes	124
Table 7-8 - Overall Performance Rating	125

## LIST OF FIGURES

	<u>Page</u>
Figure 1-1 - Arctic Fuels Dispensing Equipment (AFSSP)	2
Figure 1-2 - Arctic Fuels Dispensing Equipment (AFARE)	3
Figure 1-3 - Logical Flow of Topics	7
Figure 2-1 - Overall Systems Analysis Procedure	9
Figure 3-1 - Schematic Diagram of AFARE System	53
Figure 3-2 - Schematic Diagram of Single Product AFSSP Dispensing System	54
Figure 3-3 - Schematic Diagram of Fuel Product Dispensing AFSSP System	55
Figure 3-4 - Schematic Diagram of AFARE System with Rigid Shelters	56
Figure 4-1 - Solid Propellant Gas Pressurization System For Fuel Dispensing	67
Figure 5-1 - Diagram of Concept 1 for AFARE with Centrifugal Pump and Gas Turbine Engine	69
Figure 5-2 - Transformation Function for Capital Costs	88
Figure 6-1 - Performance Capabilities of Various Batteries	99
Figure 6-2 - Relative Capacity of Lead-Acid Storage Batteries at Normal and Low Temperatures	101
Figure 6-3 - Effect of Temperature on the Viscosity of Sulfuric Acid Solutions, and the Limitations Imposed by Freezing Points	101
Figure 6-4 - Capacity of Ni-Cd Pocket Cells at Different Temperatures and Densities of Electrolyte	102
Figure 6-5 - Capacity of High-Rate NiCd Cells at Different Temperatures and Loads to a Final Voltage of 0.80 V. Density of the Electrolyte	102
Figure 6-6 - Discharge of Li/SOCL <sub>2</sub> : 1.8 M LiAlCl <sub>4</sub> /C Cells at Various Temperatures	103
Figure 6-7 - Low Temperature Stiffness of Elastomers	105
Figure 6-8 - Chemical Resistance of Low Temperature Elastomer	106
Figure 6-9 - Selection and Service Guide for Rubbers	107

## EXECUTIVE SUMMARY

The United States Army has identified a requirement for fuel dispensing systems for military units to supply fuel in the arctic at temperatures down to  $-60^{\circ}\text{F}$ . The U.S. Army Mobility Equipment Research and Development Command (MERADCOM) commissioned this study to determine the most promising approach to develop arctic counterparts to two of the Army's current fuel dispensing subsystems; the fuels system supply point (or FSSP) and the forward area refueling equipment (or FARE).

There were two major problems in modifying the current subsystem design for use in the arctic: first, it is very difficult to start and operate pump drive equipment in the arctic at temperatures of  $-60^{\circ}\text{F}$ ; and second, elastomeric materials become too brittle to function at low temperatures. It was necessary to identify materials and components that overcome these problems or system concepts that avoid them and then to devise a method for soliciting from among these the most promising candidates for development, considering all technical and practical constraints. The study was carried out as follows:

- All systems that we could conceive as possible for arctic fuel dispensing were tabulated.
- All possible systems attributes that bear on system utility were also tabulated. More than thirty attributes relating to performance, availability and reliability, development risk, cost, and flexibility and ease of use were considered.
- A scoring system (actually, a sequence of increasingly more refined and detailed scoring systems) was devised to relate the value and importance of each attribute to a common scale.
- Competing systems were evaluated according to the scoring system. An initial evaluation with an abbreviated list of aggregated attributes was made first to reduce the number of candidate alternatives without eliminating any of the best. The remaining alternatives were reevaluated at an increased level of detail.

After the end of the final phase of the evaluation, systems were rated according to four numerical summary scores. These scores rated the following consolidated attributes:

- Life cycle cost
- Development risk
- Size and weight index
- Overall performance

From the scores in those four attributes categories we have drawn the following conclusions and recommendations:

For an arctic application of the AFARE system:

- With additional development the current Army concepts (See Chapter 1 and Appendix 1) can be used effectively in the arctic. In particular, a variation of the current design using a centrifugal pump and a gas turbine engine was the highest performing system that we analyzed. This concept uses either advanced batteries or a gas start and magneto. Neither variant is the least expensive among the alternatives nor does either require the least development, but they are the best performers as well as being the lightest and the smallest. A recirculating system using a diesel engine costs less and performs well, but it is heavier and larger.

For an arctic application of the AFSSP system:

- The current concept can be used in the arctic with additional development. The appropriate components would also be gas turbine engine, advanced elastomers, and either a compressed gas start or advanced batteries. These system options make the system more expensive and involve more development risk than some alternatives. They meet the stated size, weight, and specifications, however, and are the best performing systems.
- A lower cost but lower performing system than the modified current design that also meets the size and weight restrictions is a sheltered system with continuous or intermittent heater and a diesel engine drive. This candidate is a reasonable performer and worthy of consideration if the Army is sensitive to total cost.

For both systems:

- If the Army is mainly concerned with maximizing performance, the current designs with both a compressed gas start and redundant advanced battery would be appropriate. The systems would raise cost, size and weight a moderate amount but maximize reliability and other performance characteristics.

The major areas of development that we foresee for the AFARE and AFSSP applications in the arctic are advanced batteries and elastomerics. Elastomerics is currently the most crucial area of development. Products manufactured by Goodyear and Firestone can maintain flexibility at arctic temperatures but might require additional development and refinement. Currently, there are no fuel storage tanks that are collapsible at arctic temperatures of  $-60^{\circ}\text{F}$ . Future development in hoses and collapsible fuel tanks is extremely important for the successful implementation of these fuel dispensing systems.

## CHAPTER 1 - INTRODUCTION AND BACKGROUND

The United States Army has identified a requirement for providing fuel dispensing systems that will supply fuel in the arctic at temperatures down to  $-60^{\circ}\text{F}$ . Current systems in the military inventory operate with increasingly poorer efficiencies down to lower temperature limits in the range of  $-25^{\circ}\text{F}$  due principally to poor low temperature properties of existing elastomeric components and poor engine start-up capabilities in the extreme cold.

In January 1979, the U.S. Army Mobility Equipment Research and Development Command (MERADCOM) engaged Arthur D. Little, Inc. to conduct a systems analysis of viable alternative approaches for providing arctic fuel dispensing equipment (AFDE) systems. MERADCOM's interest was to identify all possible systems and systematically analyze and rank the possible approaches. To be included in the examination of alternatives were the Army's current subsystems, Fuel System Supply Points (FSSP), to be designated AFSSP (for arctic), and Forward Area Refueling Equipment to be designated AFARE. Included also in the examination of alternatives specifically were to be the elastomeric components of candidate systems (hoses, seals, gaskets, and collapsible fuel storage containers) and low temperature engine start-up capabilities for the fuel pump drive systems. Artists conceptions of these systems are presented in Figures 1-1 and 1-2.

The U.S. Army has identified the following general missions and specific operational requirements for the AFSSP and AFARE subsystems of the AFDE systems:

- The broad mission of the AFDE systems is to satisfactorily supply fuel for military operations in areas with temperatures ranging from  $+90^{\circ}\text{F}$  down to  $-60^{\circ}\text{F}$  in the arctic.
- The mission of the AFSSP is to serve as the bulk fuel receiving, storage, and issuing facility for the immediate resupply of corps, divisional, nondivisional, and brigade units that are operating at temperatures down to  $-60^{\circ}\text{F}$ . The issuing function will involve primarily dispensing the stored fuel to small bulk containers for transport to forward operational areas. It will secondarily be capable of performing a service station type function when necessary and dispense directly to mobile fuel consuming equipment.

**ARCTIC FUELS DISPENSING EQUIPMENT**  
ARCTIC FUEL SYSTEMS DEVELOPMENT

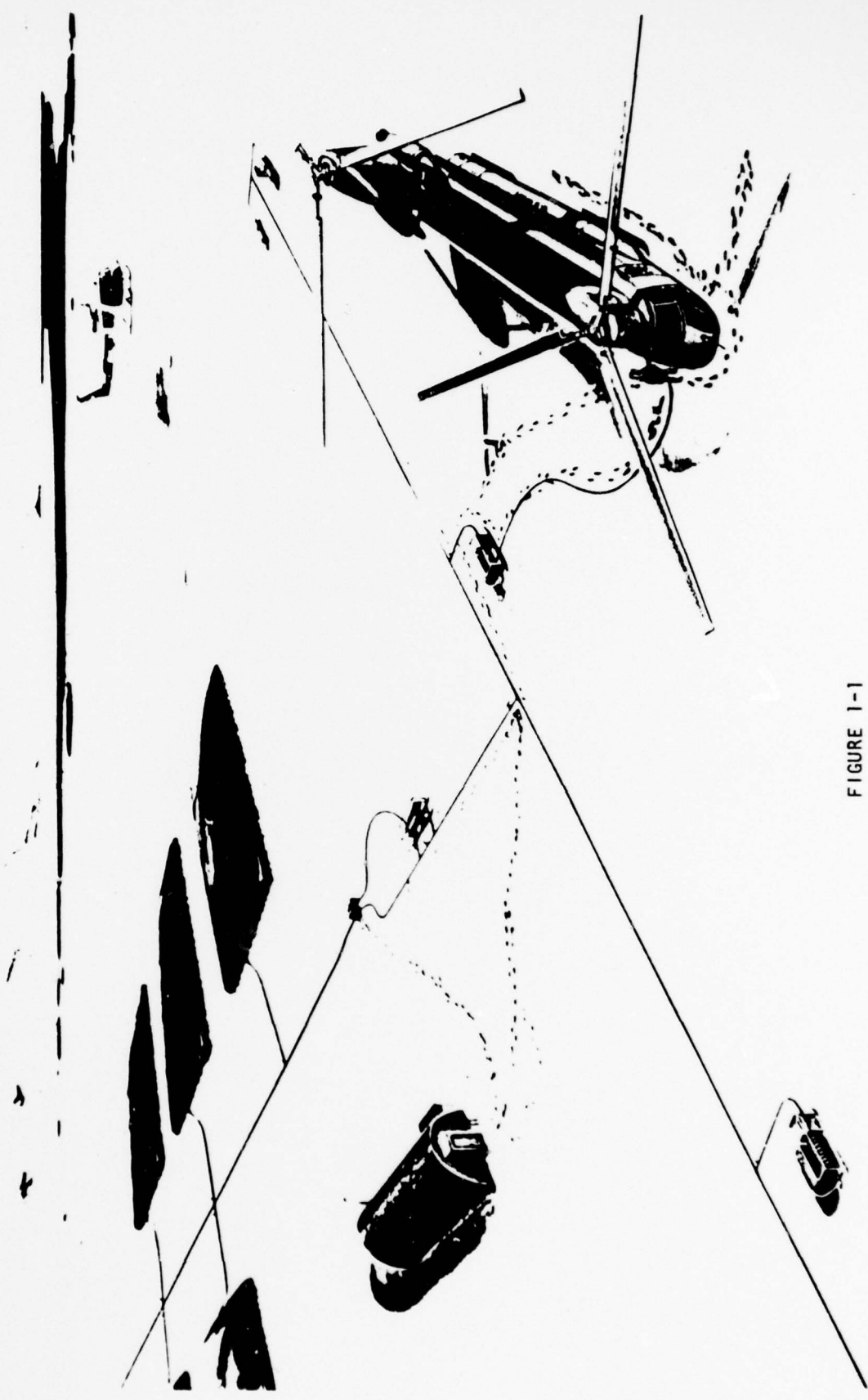

FIGURE 1-1  
(U.S. Army Photograph)

**ARCTIC FUELS DISPENSING EQUIPMENT**  
**ARCTIC FORWARD AREA REFUELING EQUIPMENT**

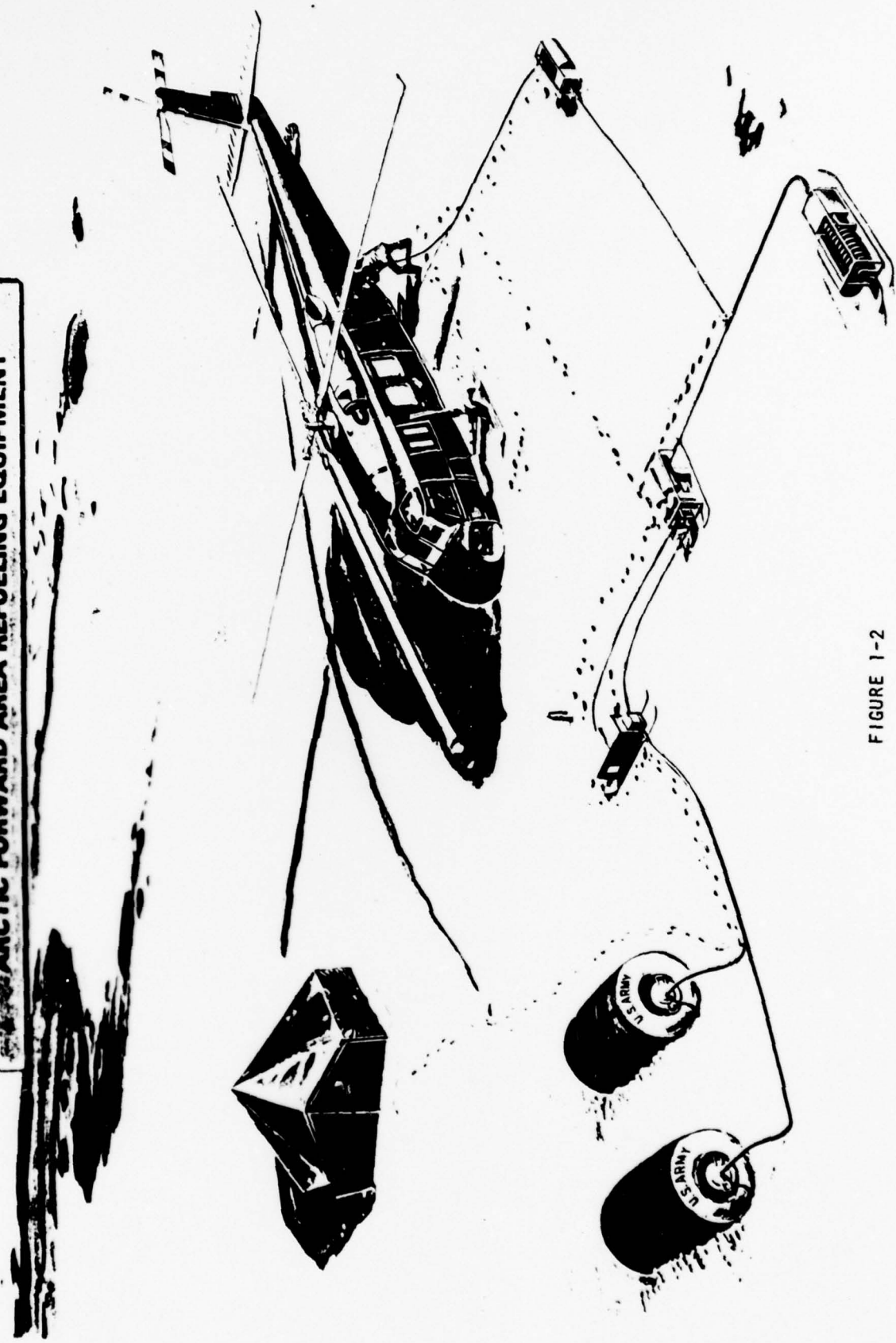

FIGURE 1-2  
(U.S. Army Photograph)

- The mission of the AFARE is primarily to refuel attack helicopters as far forward on the battlefield as possible at temperatures down to  $-60^{\circ}\text{F}$ . These systems must be deployable by utility helicopters. They must be capable of receiving bulk fuel resupply by helicopters, by all types of bulk fuel tankers, and by C-130 bladder birds. The AFARE must also be capable of refueling ground support equipment.

The operational requirements for acceptable systems are listed in Appendix 1. In conducting this study, Arthur D. Little performed the following tasks:

- Obtained a clear definition of the mission and performance requirements for the arctic FSSP and the arctic FARE systems.
- Confirmed the various operational, equipment performance, and materials problems associated with operations in the arctic at temperature extremes down to  $-60^{\circ}\text{F}$ .
- Developed a comprehensive listing of possible equipment systems configurations which could perform the missions for the AFSSP and the AFARE.
- Refined the possible systems into feasible alternative technical approaches.
- Performed a rank ordering of the feasible alternatives.
- Identified further development required, relative likelihood of success, and estimated costs.
- Formulated recommendations for component testing and additional data required to allow a decision for an advanced development follow-on program.

Arthur D. Little's broad approach in identifying, refining, and finally selecting the most feasible alternatives began with developing the most comprehensive list possible of scenarios which could work. No constraints such as practicality, details of systems designs, development costs or time requirements, known Army employment doctrine, or adverse effects of  $-60^{\circ}\text{F}$  temperature environment were initially considered in the first listing. As explained in detail in subsequent chapters, the alternatives in this first listing for both AFSSP's and AFARE's were ranked and scored in terms of feasibility with the first elimination based primarily on the criteria of acceptable performance in the arctic. Our early study research into current cold weather practices and technology was used for this first evaluation effort and for the development of final alternatives. A final evaluation and ranking of the remaining alternatives was accomplished based on cost factors and differences in details of system components.

The results of this study have been organized into the following topics, each of which is presented in a separate chapter.

Chapter 1: Introduction and Background

Chapter 2: Systems Analysis Methodology

This chapter presents the attributes of arctic refueling systems that have bearing on their usefulness and a systems analysis approach in evaluating alternatives subject to such multiple attributes. The chapter presents the methodology by which the remaining analysis is performed.

Chapter 3: Technical Approaches and Alternatives

This chapter presents a description of all the concepts considered for AFARE and AFSSP.

Chapter 4: Preliminary State-of-the-Art Research

This chapter presents the preliminary state-of-the-art research for arctic refueling operations. Included are the results from an extensive field trip to the arctic.

Chapter 5: First Phase Evaluation

This chapter presents the systems evaluation of the various alternatives. The results of the evaluation were a determination of a limited set of alternatives utilized in a second phase evaluation.

Chapter 6: Final State-of-the-Art Research

This chapter presents the results of second phase state-of-the-art research. These research issues arose out of the results of the first phase evaluation and were directed at the uncertainties involved in the favored systems.

Chapter 7: Final Evaluation of Alternatives

This chapter presents the systems analysis evaluation of the final alternatives which leads to the recommendation for the most favored systems. The methodology, which includes a four valued vector evaluation of each alternative, is also presented.

Chapter 8: Recommendations for Future Development and Testing Requirements

Based on the final evaluation and recommendations concerning favored systems, this chapter presents recommendations for development and testing.

Figure 1-3 depicts the logical flow of the chapters. Chapters 2, 5, and 7 are geared toward the systems analysis approach of the study. Chapters 3, 4, and 6 are geared toward the engineering issues and alternatives. Chapters 1 and 8 deal with the overall study.

FIGURE 1-3  
LOGICAL FLOW OF TOPICS

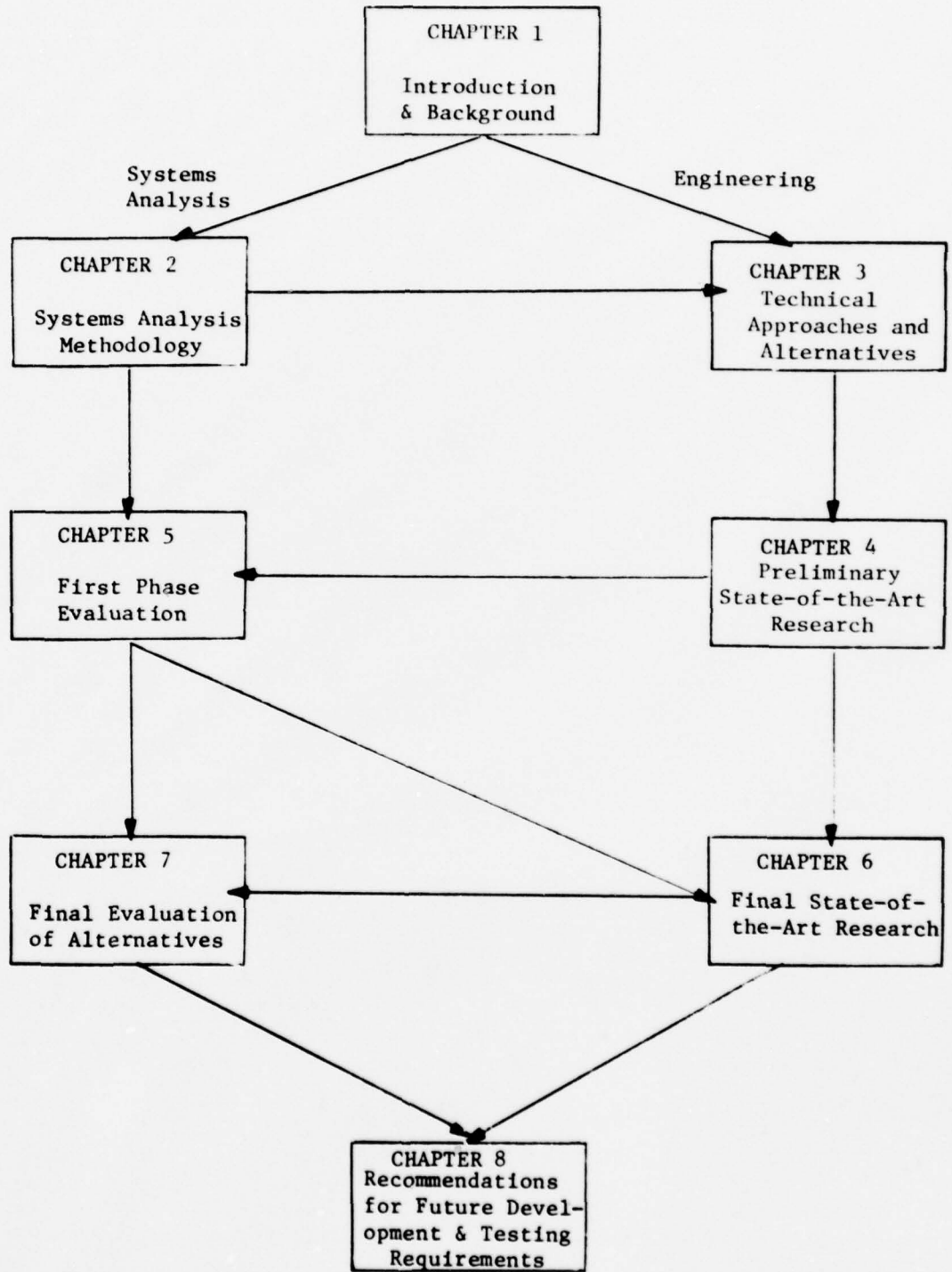

## CHAPTER 2 - SYSTEMS ANALYSIS METHODOLOGY

### 2.1 GENERAL METHODOLOGY

The overall method of identifying concepts most appropriate for the AFARE and AFSSP systems was a systems analysis approach consisting of two major steps:

- Identification of alternative system concepts
- Systems evaluation of the alternative concepts in terms of the systems attributes

The actual process was somewhat more involved in that, first, the attributes appropriate for systems evaluation had to be identified, and second, the evaluation procedure was an iterative one involving two phases. A flowchart for the overall procedure is depicted in Figure 2-1.

In identifying system attributes, those characteristics of the systems that we believed might be useful in evaluation were tabulated and categorized. These attributes spanned the range of cost and performance characteristics. After each evaluation, the attribute list was refined by aggregation and in some cases, elimination. Attributes were eliminated if there were no discernable differences with respect to that attribute among the remaining system concepts.

For example, none of the identified system concepts appeared to show any advantages with respect to system security, so this attribute was dropped from consideration. Aggregation was utilized whenever practical among related attributes.

Evaluation of systems attributes was performed in several ways. One method was a qualitative evaluation that compares the relative merits of competing systems. As an example, a relative scale of 0 to 5 was frequently utilized where 5 represented the best relative score for a particular attribute and 0 represented the lowest relative score. Another method was the actual numerical value of certain attributes. As an example, in the final phase of evaluation, life cycle cost in estimated dollars expended over a ten year period was utilized as a basis for comparison.

The most desirable method of analysis would have been to develop complete detail for all attributes of each system under evaluation. However, this was not feasible in this instance and the heart of the methodology became

FIGURE 2-1  
OVERALL SYSTEMS ANALYSIS PROCEDURE

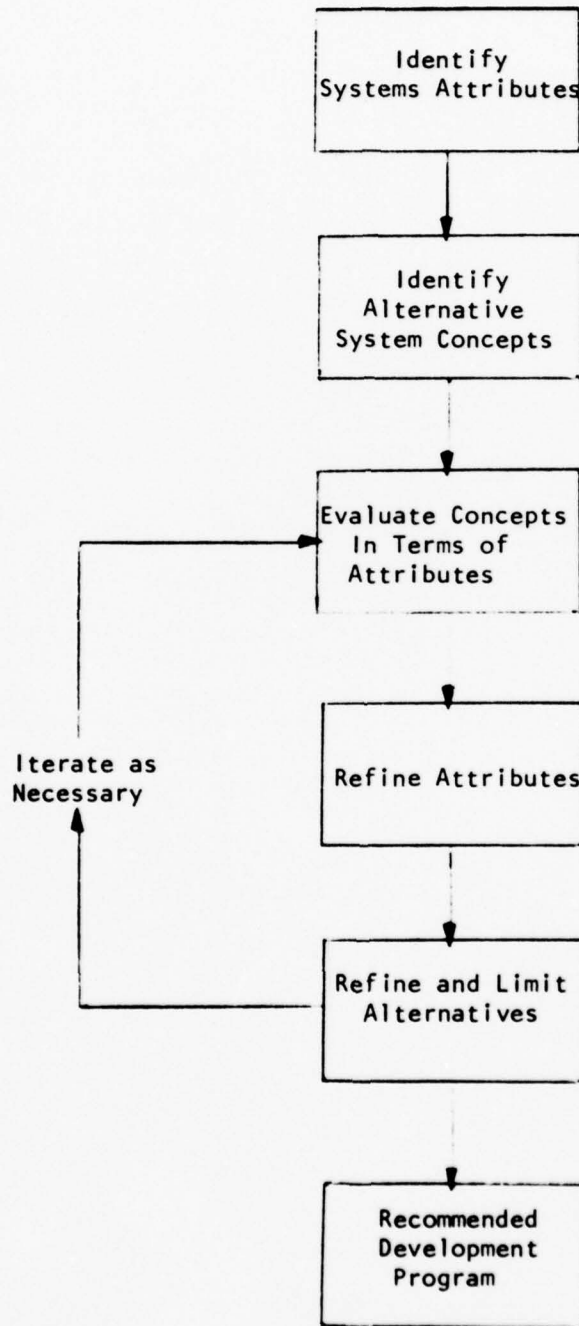

an iterative evaluation procedure. In the first phase, all attribute evaluations were qualitative using relative measures to eliminate alternatives that were clearly less desirable than others. In subsequent phases of evaluation the remaining systems were defined in increasing detail to permit more detailed comparison of system attributes. As the iteration method proceeded the variation in attributes between competing concepts were reduced and it became necessary to identify minor differences between concepts. In the final phase of evaluation the level of detail was sufficient to identify the most promising system concept.

The actual overall evaluation in each of the iterative steps consisted of

- A qualitative or quantitative evaluation of each attribute for each system or system component.
- A scoring or trade-off analysis to evaluate each system subject to its scores on the various attributes.

The scoring involved the weighting of each attribute score for an overall system score. In the final phase of evaluation, however, a somewhat modified method of system trade-off was utilized. The detailed methodologies for system scoring and evaluation are described in the first and second phase evaluations in chapters 5 and 7.

## 2.2 IDENTIFICATION OF ATTRIBUTES

In order to evaluate each of the concept systems, a list of system attributes was developed. In each of the evaluation phases, the attribute list was reduced to some extent to reflect possible aggregation and eliminations (the latter when there was little or no variations among systems). These are discussed in the sections on first and second phase evaluation. The attribute list in this chapter represents a complete list of system characteristics judged to be of importance by MERADCOM, without regard to relative importance, overlap, discriminatory ability, or level of appropriate detail. Therefore, all of the following were considered, but possibly not utilized in later evaluations. Subsequently, in the first phase evaluation, the list was modified and reduced.

The attributes consist of characteristics encompassing

- Performance specifications
- Availability - Reliability
- Development Risk
- Cost
- Flexibility and ease of use
- Other factors

and include:

1. Performance Specifications

- Capability of system in meeting requirements for
  - capacity
  - refueling
  - off-loading
- System turn around speed for off-loading
- System response capability for refueling tasks
- Fuel flexibility

2. Availability-Reliability

- Probability of system being available and functional at
  - 60°F
  - 50°F
  - 40°F
  - 25°F
  - 0°
  - +32°F
  - +90°F
- System Lifetime - Average time until system is scrapped or replaced due to simultaneous obsolescence of major components.

3. Development Risk

- Probability of implementation using current technologies within
  - 1982
  - 1985
  - 1988
- Probability of developing the following components within time period
  - hoses
  - filter
  - pump and drive
  - seals
  - collapsible drums
  - nozzles
  - clothing
- Probability of implementing integrated system assuming components can be developed

- Variability of development cost for
  - hoses
  - filter separators
  - pump and drive
  - seals
  - collapsible drums
- Dependence on undeveloped or high-cost materials. i.e.,
  - very high
  - high
  - moderate (high cost but definitely available and needed only for limited quantities)
  - little or none

#### 4. Cost

- Annualized cost of capital by component
- Development costs for
  - hoses
  - filter
  - pump and drive
  - seals
  - collapsible drums
  - nozzles
  - clothing
- Development cost for integrated system
- Operating cost
  - fuel for pump drive
  - replacement parts
  - inventory
  - manpower to operate
  - extra manpower for maintenance

#### 5. Flexibility and Ease of Use

- Size
- Weight
- Ease of Operation
- Set-up Time
- Dismantling time
- Terrain performance and on-site restrictions
  - rugged terrain
  - thick brush or timber

- Operational dependence on special tools, skills
- Maintenance dependence on special tools, skills
- Transportability
- Ability of system to stand alone

#### 6. Other Factors

- Safety of personnel
- Security
- Vulnerability for 9 situations listed in LOA
- Environmental compatibility
- Maintenance time (man-hours/year) for system as a function of the individual components
- Maintenance frequency for system

The goal in developing the attribute list was the consideration of all possible factors in rating competing systems. At each evaluation stage, attributes were refined to a degree commensurate with the evaluation. In the first stage of evaluation the goal was to rank the competing systems with respect to the above list of attributes. Attributes were aggregated only when the precision obtainable was not commensurate with the detail of the original attribute list. This procedure is described in Chapter 5.

## CHAPTER 3 - TECHNICAL APPROACHES AND ALTERNATIVES

This chapter describes the principal arctic fuel dispensing systems and variants of them that were compared in this study. We started with the present FARE and FSSP systems, added concepts and ideas suggested by the staff at MERADCOM, conducted a "brainstorming" session with about a dozen engineers at Arthur D. Little, and informally surveyed the literature. After assembling an initial collection of concepts, we investigated the plausibility of combining features of one concept with features of another to make new combinations. Finally, we sorted the resulting list into groups having similar features.

In the end, we had ten basic alternative arctic fuel dispensing system concepts, most of which had one or more plausible variants. Some concepts or variants are appropriate only for AFARE, some only for AFSSP, and some are appropriate for both. This chapter describes 17 variants of the basic ten that were identified for AFARE and 18 that were identified for AFSSP. Each is potentially subject to four further minor variations of such a nature that they can be applied to any of the 35. Based on preliminary state-of-the-art information which was gathered shortly after these initial listings, these variants were further modified to 16 base scenarios for AFARE and 21 for AFSSP for the first evaluation. The four minor variants were changed to include pump possibilities, pump drive possibilities, hose alternatives, and storage tank alternatives. All were rated separately and the number of alternative systems were reduced quickly to manageable proportions for final evaluation as described in Chapter 5. Nevertheless, the initial alternatives which follow form the basis for the final alternatives rated further in this study.

The 10 original base concepts include the following:

1. Systems utilizing in concept the current FSSP and FARE configuration. (See Figures 3-1, 3-2, and 3-3) Within these guidelines, there are the following component variations:
  - a. Pumps
    - (1) Special scroll pumps (A.D. Little designed item)
    - (2) Peristaltic pumps
    - (3) Centrifugal pumps
    - (4) Positive displacement pumps

b. Pump Drive Systems

- (1) Gas-turbine engine
- (2) Gasoline engine
- (3) Diesel Engine
- (4) Electrical motor
- (5) Double gas turbine

2. Systems similar to the current FSSP and FARE configurations but which utilize some type of energy storage or alternative energy source to help start the pump drive equipment. These devices include:
  - a. Exhaust heat<sup>1</sup> from the vehicle being refueled
  - b. Continuous self heater
  - c. Portable heater for drive only
  - d. Compressed air/gas start
  - e. Other type of energy storage
  - f. Some type of intermittent unattended heater
3. Systems similar to current FSSP and FARE configurations excepting an accumulating compressed air/gas pumping system which replaces other pumping equipment. Compressed air/gas is generated by
  - a. Compressor using conventional drive engines for compressed air.
  - b. Solid propellant energy source for compressed gas.
4. Systems with an inflatable, insulated shelter erected on site to protect pump/pump drive and filter/separator assemblies and operating personnel.
5. Systems similar to current systems but with the pump/pump drive and filter/separator assemblies permanently housed in a rigid enclosure on a truck, or trailer or within a cabinet, each of which could be transported as a unit by large helicopters. Critical parts of components within the enclosure would be heated.
6. Systems which have all or part of the components housed on a vehicle, for example:
  - a. All on a truck, such as a tanker truck or trailer containing a fuel storage tank, pump, filter/separator, and hoses on reels.

---

<sup>1</sup> (Not suitable for AFARE because helicopters have to be shut down on refueling due to static electricity risk - See Chapter 4).

- b. All on a helicopter, i.e., a helicopter dedicated to this fuel dispensing mission which contains a fuel storage tank, pump, filter/separator, and hoses on reels.
  - c. All components mounted on a truck or trailer except the fuel storage tanks.
  - d. All components mounted on a dedicated helicopter except the fuel storage tanks.
7. Systems with added hose and valving arrangement to permit continuous complete system low rate recirculation at temperatures in the  $-60^{\circ}\text{F}$  range.
8. Systems having certain components which are or would be mounted permanently on all ground vehicles and helicopters receiving standard military fuels:
  - a. One concept would be systems identical to current systems less pump/pump drive and filter/separator assemblies which would be mounted on all vehicles.
  - b. Another concept would be systems identical to current systems less only the pump drive assemblies. Pump drives would be by power take off from vehicle and and helicopter accessory equipment (i.e., by modification of the winch assemblies, etc.)
9. Systems similar to current systems with the pump drive system utilizing advanced energy sources such as:
  - a. Atomic energy
  - b. Microwave energy
  - c. Wind power energy
  - d. Solar energy
10. Systems similar to current systems excepting rigid fuel storage containers to be mounted on trucks or on flat bed trailers and transported to and parked on sites by ground vehicles. Smaller rigid tanks could be helicopter transported to sites and replaced in the same manner when emptied.

There are four variations on components of the system that can be used to develop the multiple combination described above. These include:

- a. Use of rigid pipeline materials (for instance, aluminum) for long runs of pipe in conjunction with short pieces of flexible hose. The short flexible hose would be used as required to provide flexibility in placing the piping systems on rough,

uncleared terrain or for connecting components at variable elevations on site. Transportability, flexibility and ease of operation will decrease, but reliability and dependence on high-cost materials could be advantageous.

- b. Use of redundancy in incorporation of multiple pumps, pump drive systems, fuel filter/separator units and other key components in the overall systems for added reliability. Transportability would, of course, decrease.
- c. Use of less expensive rubber compounds when developed for hoses, seals, and gaskets. Reliability may decrease, and development cost variations could increase, but dependence on high cost materials will decrease.
- d. Use of small diameter, higher pressure hose. This option will reduce the cost, weight and size of hosing, but will necessitate a change to types of pumps which are heavier and more costly.

The remainder of this chapter presents a description of each AFARE and AFSSP alternative according to a common format.

AFARE  
ALTERNATIVE 1  
Similar to FARE

1. All separate components as listed below capable of operating at -60°F. Ground vehicle and helicopter transportable (exclusive of collapsible drums which would be airlifted to site separately).
2. One 200 GPM pump and pump drive assembly using combinations of any of the following:
  - a. Pumps
    - (1) Scroll pumps (A.D. Little proprietary item)
    - (2) Peristaltic pumps
    - (3) Centrifugal pumps
    - (4) **Positive Displacement Pumps**
  - b. Pump Drives
    - (1) Gas turbine engine (30 hp)
    - (2) Gasoline engine
    - (3) Diesel engine
    - (4) Electric motor
    - (5) **Double gas turbine**
3. One 200 GPM fuel filter/separator
4. Fuel storage consists of two or more 500 gallon collapsible drums carried to site by sling loading to helicopters.
5. Flexible hoses, approximately 300 feet of 2 inch discharge hose and 60 feet of 2 inch suction hose with valves, fittings, seals and gaskets.
6. Two nozzles and dispensing points capable of closed circuit and/or open port refueling of two medium helicopters simultaneously and other equipment as required.
7. Resupply of AFARE accomplished by helicopter transporting 500 gallon replacement collapsible drums from AFSSP.

Advantages/Disadvantages

Fully air and ground transportable, high on flexibility, fully meets all criteria , fairly high on development risks, high on capital costs.

AFARE  
ALTERNATIVE 2b\*  
Continuous Heating

1. Pump and pump drive and filter/separator assemblies receiving special treatment (See paragraph 8 below). Other components upgraded to -60°F capabilities and employed in open, unprotected status.
2. One 200 GPM pump driven by 30 H.P. gas turbine engine.
3. One 200 GPM fuel filter/separator.
4. Fuel storage consists of two or more 500 gallon collapsible drums carried to site by helicopters.
5. Flexible hoses, approximately 300 ft of 2 inch discharge hose and 60 feet of 2 inch suction hose with valves, fitting, seals and gaskets.
6. Two nozzles and dispensing points capable of closed circuit and/or open port refueling of two medium helicopters simultaneously and other equipment as required.
7. Resupply of AFARE accomplished by helicopter transporting 500 gallons replacement collapsible drums from AFSSP.
8. Pump/pump drive and filter/separator assemblies to be mounted in covered light truck or trailer or in skid mounted container which is heated by the pump drive engine or alternate heater kept running almost continuously during extreme cold temperatures or intermittently when system not in use at low extreme temperatures. These covered components to be helicopter transportable.

Advantages/Disadvantages

Increases reliability of starting and operations, decreases development costs because key components do not have to meet -60°F entered. High operating and maintenance costs, reduces transportability, increases capital costs.

\* This description applies to 2b and 2e

AFARE  
ALTERNATIVE 2c  
Portable Heater

1. Pump and pump drive and filter/separator assemblies receiving special treatment (See paragraph 8 below). Other components upgraded to -60°F capabilities and employed in open, unprotected status.
2. One 200 GPM pump driven by 30 H.P. gas turbine engine.
3. One 200 GPM fuel filter/separator.
4. Fuel storage consists of two or more 500 gallon collapsible drums carried to site by helicopters.
5. Flexible hoses, approximately 300 ft of 2 inch discharge hose and 60 feet of 2 inch suction hose with valves, fitting, seals and gaskets.
6. Two nozzles and dispensing points capable of closed circuit and/or open port refueling of two medium helicopters simultaneously and other equipment as required.
7. Resupply of AFARE accomplished by helicopter transporting 500 gallons replacement collapsible drums from AFSSP.
8. Pump/pump drive and filter/separator assemblies to be mounted in covered light truck or trailer or in skid mounted container. Pump drive unit and filter/separator assembly would be heated by small hand-held heater (using propane fuel for instance) for sufficient period before dispensing from system to enable equipment to heat up, start, and operate effectively. The covered components to be helicopter transportable.

Advantages/Disadvantages

Increases reliability of starting but requires delayed starting of system. Requires additional fuel and ease of operation is reduced. Reduces transportability and increases capital costs.

AFARE  
ALTERNATIVE 2c  
Compressed Gas Starting

1. Pump and pump drive and filter/separator assemblies receiving special treatment (See paragraph 8 below). Other components upgraded to -60°F capabilities and employed in open, unprotected status.
2. One 200 GPM pump driven by 30 H.P. gas turbine engine.
3. One 200 GPM fuel filter/separator.
4. Fuel storage consists of two or more 500 gallon collapsible drums carried to site by helicopters.
5. Flexible hoses, approximately 300 ft of 2 inch discharge hose and 60 feet of 2 inch suction hose with valves, fitting, seals and gaskets.
6. Two nozzles and dispensing points capable of closed circuit and/or open port refueling of two medium helicopters simultaneously and other equipment as required.
7. Resupply of AFARE accomplished by helicopter transporting 500 gallons replacement collapsible drums from AFSSP.
8. Pump/pump drive and filter/separators kept in open. Compressed dry nitrogen gas used to assist pump drive start up by passing the gas through an air starter motor on the pump drive.

Advantages/Disadvantages

Assists in start up. Increases complexity of operations somewhat and increases maintenance requirements.

AFARE  
ALTERNATIVE 3a  
Compressed Air Pumping

1. Components similar to FARE and able to operate at -60°F except that pumping is accomplished by compressed air stored for that purpose.
2. Compressed air is generated by a compressor driven by a gas-turbine engine and stored in a separate tank. The compressed air pumps fuel from a redundant accumulator tank system at 200 GPM to the dispensing nozzles. The accumulators are recharged with fuel at low rates by compressed air expelling fuel from the storage tanks to the accumulators when the system is not in the dispensing mode.
3. One 200 GPM filter/separator unit.
4. Two or more 500 gallon collapsible fuel storage drums brought from the rear by helicopter.
5. Approximately 300 feet of flexible 2 inch discharge hose and 60 feet of 2. inch suction hose with valves, fittings, seals and gaskets.
6. Two nozzles and fuel dispensing points.
7. Helicopter carry replacement 500 gallon drums from the rear.

Advantages/Disadvantages

Delete requirement for conventional pump. Increases complexity of operations and increases maintenance. Reduces reliability and availability. May entrain air in fuel. Cooling effect of air expansion may cause localized freezing of fuel supply.

## AFARE

### ALTERNATIVE 3b

#### Compressed Gas Pumping

1. Components similar to FARE and able to operate at -60°F except that pumping is accomplished by compressed gas stored for that purpose.
2. Compressed gas is generated by igniting a solid propellant and stored in a separate tank. The compressed gas pumps fuel from a redundant accumulator tank system at 200 GPM to the dispensing nozzles. The accumulators are recharged with fuel at low rates by compressed gas expelling fuel from the storage tanks to the accumulators when the system is not in the dispensing mode.
3. One 200 GPM filter/separator unit.
4. Two or more 500 gallon collapsible fuel storage drums brought from the rear by helicopter.
5. Approximately 300 feet of flexible 2 inch discharge hose and 60 feet of 2 inch suction hose with valves, fittings, seals and gaskets.
6. Two nozzles and fuel dispensing points.
7. Helicopter carry replacement 500 gallon drums from the rear.

#### Advantages/Disadvantages

Delete requirement for conventional pump. Increases complexity of operations and increases maintenance. Reduces reliability and availability. May entrain gas in fuel. **Cooling effect of gas expansion may cause localized freezing of fuel supply.**

**AFARE**  
**ALTERNATIVE 4**  
**Inflatable Shelter**

1. Pump and pump drive and filter/separator assemblies receiving special treatment (See paragraph 8 below). Other components upgraded to -60°F capabilities and employed in open, unprotected status.
2. One 200 GPM pump driven by 30 H.P. gas turbine engine.
3. One 200 GPM fuel filter/separator.
4. Fuel storage consists of two or more 500 gallon collapsible drums carried to site by helicopters.
5. Flexible hoses, approximately 300 ft of 2 inch discharge hose and 60 feet of 2 inch suction hose with valves, fitting, seals and gaskets.
6. Two nozzles and dispensing points capable of closed circuit and/or open port refueling of two medium helicopters simultaneously and other equipment as required.
7. Resupply of AFARE accomplished by helicopter transporting 500 gallons replacement collapsible drums from AFSSP.
8. Pump/pump drive and filter/separator assemblies placed within shelters (**domes**) fabricated on site. These would be inflatable double-walled domes with aluminized fabric for internal reflection within the space between walls and the space filled with foam. The area within the domes would be heated by **personnel heating systems used by operating personnel.**

**Advantages/Disadvantages**

Increases reliability of starting and operating system, increases complexity of operations and time for set up. Increases capital costs.

**AFARE**  
**ALTERNATIVE 5**  
**Rigid Shelter**

1. Pump and pump drive and filter/separator assemblies receiving special treatment (See paragraph 8 below). Other components upgraded to -60°F capabilities and employed in open, unprotected status. (See Figure 3-4.)
2. One 200 GPM pump driven by 30 H.P. gas turbine engine.
3. One 200 GPM fuel filter/separator.
4. Fuel storage consists of two or more 500 gallon collapsible drums carried to site by helicopters.
5. Flexible hoses, approximately 300 ft of 2 inch discharge hose and 60 feet of 2 inch suction hose with valves, fitting, seals and gaskets.
6. Two nozzles and dispensing points capable of closed circuit and/or open port refueling of two medium helicopters simultaneously and other equipment as required.
7. Resupply of AFARE accomplished by helicopter transporting 500 gallons replacement collapsible drums from AFSSP.
8. Pump/pump drive and filter/separator assemblies to be mounted in covered 3/4 ton truck bed, 3/4 ton trailer or skid mounted container which is kept heated by a battery supply or other sources. The battery supply would be recharged by general vehicle helicopter electrical systems periodically.

**Advantages/Disadvantages**

Increases ease of starting and operating system, decreases development costs of key components. Decreases system reliability and increases complexity of operations. Decreases transportability.

AFARE  
ALTERNATIVE 6a  
Truck Tankers

1. All components housed on a truck tanker containing 1500 to 2000 gallons fuel storage. The truck tanker is an AFARE.
2. 200 GPM pump/pump drive assembly.
3. 200 GPM fuel filter/separator-assembly
4. Two flexible hoses on reels with nozzles to refuel two helicopters simultaneously and other equipment as required.
5. Truck tankers will be resupplied by bulk carriers from the rear or by replacement tankers (AFARE) from the rear.

Advantages/Disadvantages

Increases ground mobility but negates helicopter transportability.  
Increases capital costs. Increases operator efficiency.

AFARE

ALTERNATIVE 6b

Helicopter Tankers

1. All components mounted in a helicopter dedicated as a tanker and constituting a completely mobile AFARE.
2. One 200 GPM pump with power take-off drive from the helicopter system.
3. One 200 GPM fuel filter/separator.
4. Fuel storage tanks contained within the helicopter - one, two, or three 500 gallon containers depending on payload of helicopter.
5. Flexible hoses on reels mounted in helicopter, approximately 300 feet of 2 inch hose with valves and fittings.
6. Two separate reels and nozzles to refuel two medium helicopters simultaneously. Nozzles for closed circuit and/or open part refueling of aircraft and other equipment.
7. Resupply of AFARE from rear done by flying in full helicopter tanker replacement and withdrawing empty helicopter to be refueled in rear area (at AFSSP).

Advantages/Disadvantages

Increases air transportability and reliability of components.  
Increases capital costs and safety risk to operations.

AFARE

ALTERNATIVE 6c

Components Except Storage Tanks Mounted on Truck or Trailer

1. All components mounted on a truck or trailer except the fuel storage drums. One truck per AFARE.
2. One 200 GPM pump/pump drive assembly.
3. One 200 GPM fuel filter/separator assembly
4. Fuel storage consists of two or more 500 gallon collapsible drums carried to site by helicopter.
5. Flexible hoses on reels on truck with valves and fittings.
6. Two hose reels with dispensing nozzles to refuel two helicopters simultaneously or other equipment as required.
7. Helicopters carry replacement 500 gallon drums from the rear for resupply.

Advantages/Disadvantages

Increases reliability of components and operations. Increases capital costs, decreases air transportability. Increases operation efficiency.

AFARE

ALTERNATIVE 6d

Components Except Storage Tanks on Helicopters

1. All components mounted on a helicopter dedicated to mission except fuel storage drums. One helicopter per AFARE.
2. One 200 GPM pump/pump drive assembly.
3. One 200 GPM fuel filter/separator assembly.
4. Fuel storage consists of two or more 500 gallon collapsible drums carried to site by other helicopters.
5. Flexible hoses on reels on helicopter with valves and fittings.
6. Two hose reels with dispensing nozzles to refuel two helicopters simultaneously or other equipment as required.
7. Other helicopters carry replacement 500 gallon drums from the rear for resupply.

Advantages/Disadvantages

Increases air transportability, reliability of system and operator efficiency. Increases capital costs. Increases safety risk.

AFARE  
ALTERNATIVE 7  
Recirculation

1. Pump and pump drive and filter/separator assemblies receiving special treatment (See paragraph 8 below). Other components upgraded to -60°F capabilities and employed in open, unprotected status.
2. One 200 GPM pump driven by 30 H.P. gas turbine engine.
3. One 200 GPM fuel filter/separator.
4. Fuel storage consists of two or more 500 gallon collapsible drums carried to site by helicopters.
5. Flexible hoses, approximately 300 ft of 2 inch discharge hose and 60 feet of 2 inch suction hose with valves, fitting, seals and gaskets.
6. Two nozzles and dispensing points capable of closed circuit and/or open port refueling of two medium helicopters simultaneously and other equipment as required.
7. Resupply of AFARE accomplished by helicopter transporting 500 gallons replacement collapsible drums from AFSSP.
8. Pumps, filter/separators, valving, hose lines and fittings kept operable by almost continuous low rate recirculating of fuel through the system when system is not dispensing fuel. Pump drive system to be kept running continuously during cold temperature extremes but can be shut down when temperatures rise sufficiently.

Advantages/Disadvantages

**Increases system operations reliability. Increases operating and maintenance costs and complexity of operations. Increases capital costs slightly.**

AFARE

ALTERNATIVE 8a

Selected Components Mounted on Vehicles Being Refueled

1. All separate components as listed below capable of operating at -60°F unprotected. Pump/pump drive and filter/separator assemblies mounted as standard equipment on all vehicles using standard military fuels.
2. Ground vehicles have one 10 GPM pump with electrical motor drive from vehicle system and an internal means to refill spare fuel drums carried on board. Helicopters have one 50 GPM pump/pump drive assembly mounted on board.
3. Ground vehicles utilize fuel filters which are currently a part of their fuel feed system. Helicopters to have one 50 GPM fuel filter/separator mounted on board.
4. Fuel storage consists of two or more 500 gal collapsible drums with valves and fittings.
5. Flexible hoses, approximately 300 feet, and 60 feet of suction hose with valves and fittings, seals and gaskets.
6. Two helicopter refueling points with nozzles to refuel other equipment as required.
7. Helicopters carry replacement 500 gallon drums from the rear for AFARE resupply.

Advantages/Disadvantages

Increases system reliability, increases turnaround rate. Increases capital costs significantly.

AFARE

ALTERNATIVE 8b

Power Take-off Drive Systems

1. All separate components as listed below capable of operating at -60°F. Air (helicopter) transportable; not vehicle mounted.
2. 200 GPM pump assembly driven by mechanical power take-off from aircraft and vehicles being serviced. i.e., from winches mounted or to be mounted on all vehicles, etc.
3. 200 GPM fuel filter separator.
4. Two or more 500 gallon collapsible drum fuel storage.
5. Flexible hoses. approximately 300 feet of 2 inch discharge hose and 60 feet of 2 inch suction hose with valves, fittings, seals and gaskets.
6. Two nozzles and dispensing points capable of closed circuit and/or open part refueling of two medium helicopters simultaneously and other equipment as required.
7. Resupply of AFARE accomplished by helicopter transporting 500 gallon replacement collapsible drums from the rear.

Advantages/Disadvantages

Increases reliability of operation but increases capital costs significantly and increases complexity of operations.

AFARE  
ALTERNATIVE 9  
Advanced Sources of Energy

1. All components similar to FARE upgraded to operate at -60°F excepting pump drive units which would utilize advanced energy sources.
2. One 200 GPM pump. Pump drives could make use of:
  - a. Atomic energy
  - b. Microwave energy
  - c. Wind Power energy
  - d. Solar energy
3. One 200 GPM fuel filter/separator assembly
4. Two or more 500 gallon collapsible drum fuel storage
5. Flexible hoses, approximately 300 feet of 2 inch discharge hose and 60 feet of 2 inch suction hose with valves, fittings, seals and gaskets.
6. Two nozzles and dispensing points for refueling two medium helicopters and other equipment as required.
7. Resupply of AFARE accomplished by helicopter transporting 500 gallon replacement collapsible drums from the rear.

Advantages/Disadvantages

Increases development risks and costs sharply. Increases maintenance cost and complexity of operations. May decrease operations costs. Decreases air transportability.

AFARE

ALTERNATIVE 10

Use of Rigid Fuel Storage Tanks

1. System components similar to FARE upgraded to be operable at -60°F excepting all fuel storage tanks which will be rigid, not collapsible; tanks sized to be carried full by helicopters to the forward areas.
2. One 200 GPM pump with gasoline-turbine engine drive.
3. One 200 GPM fuel filter/separator assembly.
4. Two or more 500 gallon rigid tank fuel storage.
5. Flexible hoses, approximately 300 feet of 2 inch discharge hose and 60 feet of 2 inch suction hose with valves, fittings, seals and gaskets.
6. Two nozzles and dispensing points for refueling two medium helicopters and other equipment as required.
7. Resupply of AFARE accomplished by helicopter transporting 500 gallon replacement rigid drums from the rear.

Advantages/Disadvantages

Decreases development of collapsible tank risks and costs. Increases reliability of operations. Decreases air transportability and increases capital costs greatly.

AFSSP  
ALTERNATIVE I  
Similar to FSSP

1. All separate components as listed below capable of operating at -60°F. Ground vehicle and air transportable but not permanently mounted in any vehicles or containers.
2. Two 600 GPM pumps and pump drive assemblies using combinations of any of the following:
  - a. Pumps
    - (1) Scroll pumps (A.D. Litte proprietary item)
    - (2) Peristaltic pumps
    - (3) Centrifugal pumps
    - (4) **Positive displacement pumps**
  - b. Pump Drives
    - (1) Gas-turbine engine (50 H.P.)
    - (2) Gasoline engine
    - (3) Diesel engine
    - (4) Electric motor
3. Two 600 GPM fuel filter/separator assemblies.
4. Six to twelve 10,000-gallon collapsible fuel storage tanks.
5. Approximately 2,400 feet of flexible hoses with valves, fittings, seals and gaskets and bulk transfer fuel manifold.
6. Six liquid-transfer loading standards for loading tank trucks and semi-trailers, two filling points for 500 gallon drums and six re-fueling points for filling vehicle fuel tanks, 55 gallon drums, and 5 gallon cans.
7. Storage tanks to be resupplied by pipeline or hoseline, tankers, railway tank cars, or tank trucks and semi-trailers.

Advantages/Disadvantages

Fully air and ground transportable, high on flexibility, fully meets all criteria, fairly high on development risks, high on capital costs.

AFSSP  
ALTERNATIVE 2a  
Exhaust Heat

1. Pump and pump drive and filter/separator assemblies receiving special treatment (see paragraph 8 below). Other components up-graded to -60°F capabilities and employed in open, unprotected status.
2. Two 600 GPM pump assemblies with 50 H.P. gas turbine engine drives.
3. Two 600 GPM filter/separator units.
4. Six to twelve 10,000 gallon collapsible fuel storage tanks.
5. Approximately 2,400 feet of flexible hoses with valves, fittings, seals and gaskets and bulk transfer fuel manifold.
6. Six liquid transfer loading standards for loading tank trucks and semi-trailers, two filling points for 500 gallon drums and six refueling points for filling vehicle fuel tanks, 55 gallon drums, and 5 gallon cans.
7. Storage tanks to be resupplied by pipeline or hoseline, tankers, railway tank cars, or tank trucks and semi-trailers.
8. Pump/pump drive and filter/separator assemblies to be mounted in covered light truck or trailer or in skid mounted containers which is kept heated at a low level temperature (by exhaust from a ground vehicle operating continuously during extreme cold temperatures.) This could be supplemented by heating from exhausts of aircraft and ground vehicles being refueled. All compartment heating by exhausts could be through heat exchangers to avoid exhaust fumes within the compartments. These covered components to be helicopter transportable.

Advantages/Disadvantages

Increases reliability of starting and operations, decreases development costs because key components do not have to meet -60°F criteria. High operating and maintenance costs, reduces transportability, additional capital costs.

AFSSP  
ALTERNATIVE 2b  
Continuous Heat

1. Pump and pump drive and filter/separator assemblies receiving special treatment (see paragraph 8 below). Other components up-graded to -60°F capabilities and employed in open, unprotected status.
2. Two 600 GPM pump assemblies with 50 H.P. gas turbine engine drives.
3. Two 600 GPM filter/separator units.
4. Six to twelve 10,000 gallon collapsible fuel storage tanks.
5. Approximately 2,400 feet of flexible hoses with valves, fittings, seals and gaskets and bulk transfer fuel manifold.
6. Six liquid transfer loading standards for loading tank trucks and semi-trailers, two filling points for 500 gallon drums and six refueling points for filling vehicle fuel tanks, 55 gallon drums, and 5 gallon cans.
7. Storage tanks to be resupplied by pipeline or hoseline, tankers, railway tank cars, or tank trucks and semi-trailers.
8. Pump/pump drive and filter/separator assemblies to be mounted in covered light truck or trailer or in skid mounted container which is heated by the pump drive engine or alternate heater kept running almost continuously during extreme cold temperatures and intermittently when system not in use at low extreme temperatures. These covered components to be helicopter transportable.

Advantages/Disadvantages

Increases reliability of starting and operations, decreases development costs because key components do not have to meet -60°F criteria. High operating and maintenance costs, reduces transportability, increases capital costs.

AFSSP  
ALTERNATIVE 2c  
Portable Heater

1. Pump and pump drive and filter/separator assemblies receiving special treatment (see paragraph 8 below). Other components up-graded to -60°F capabilities and employed in open, unprotected status.
2. Two 600 GPM pump assemblies with 50 H.P. gas turbine engine drives.
3. Two 600 GPM filter/separator units.
4. Six to twelve 10,000 gallon collapsible fuel storage tanks.
5. Approximately 2,400 feet of flexible hoses with valves, fittings, seals and gaskets and bulk transfer fuel manifold.
6. Six liquid transfer loading standards for loading tank trucks and semi-trailers, two filling points for 500 gallon drums and six refueling points for filling vehicle fuel tanks, 55 gallon drums, and 5 gallon cans.
7. Storage tanks to be resupplied by pipeline or hoseline, tankers, railway tank cars, or tank trucks and semi-trailers.
8. Pump/pump drive and filter/separator assemblies to be mounted in covered light truck or trailer or in skid mounted container. Pump drive unit and filter/separator assembly would be heated by small hand-held heater (using propane fuel for instance) for sufficient period before dispensing from system to enable equipment to heat up, start, and operate effectively. The covered components to be helicopter transportable.

Advantages/Disadvantages

Increases reliability of starting but requires delayed starting of system. Requires additional fuel and ease of operation is reduced. Reduces transportability and increases capital costs.

AFSSP  
ALTERNATIVE 2d  
Compressed Gas Starting

1. Pump and pump drive and filter/separator assemblies receiving special treatment (see paragraph 8 below). Other components up-graded to -60°F capabilities and employed in open, unprotected status.
2. Two 600 GPM pump assemblies with 50 H.P. gas turbine engine drives.
3. Two 600 GPM filter/separator units.
4. Six to twelve 10,000 gallon collapsible fuel storage tanks.
5. Approximately 2,400 feet of flexible hoses with valves, fittings, seals and gaskets and bulk transfer fuel manifold.
6. Six liquid transfer loading standards for loading tank trucks and semi-trailers, two filling points for 500 gallon drums and six refueling points for filling vehicle fuel tanks, 55 gallon drums, and 5 gallon cans.
7. Storage tanks to be resupplied by pipeline or hoseline, tankers, railway tank cars, or tank trucks and semi-trailers.
8. Pump/pump drive and filter/separators kept in open. Compressed dry nitrogen gas used to assist pump drive start up by passing the gas through an air starter motor on the pump drive.

Advantages/Disadvantages

Assists in start up. Increases complexity of operations somewhat and increases maintenance requirements.

AFSSP

ALTERNATIVE 3a

Compressed Air Pumping

1. Components similar to FSSP and able to operate at -60°F except that pumping is accomplished by compressed air stored for that purpose.
2. Compressed air is generated by a compressor driven by a gas turbine engine and stored in a separate tank. The compressed air pumps fuel from a redundant accumulator tank system at 600 GPM to the dispensing components. The accumulators are recharged with fuel at low rates by compressed air expelling fuel from the storage tanks to the accumulators when the system is not in the dispensing mode.
3. Two 600 GPM filter/separator units.
4. Six to twelve 10,000 gallon collapsible fuel storage tanks.
5. Approximately 2,400 feet of flexible hoses with valves, fittings, seals and gaskets and bulk transfer fuel manifolds.
6. Six liquid-transfer loading standards for bulk loading, two 500 gallon drum filling points, and six refueling points for filling vehicle fuel tanks, 55 gallon drums, and 5 gallon cans.
7. Storage tanks to be resupplied by pipeline, hoseline, tankers, railway tank cars, or tank trucks and semi-trailers.

Advantages/Disadvantages

Deletes requirement for conventional pump. Increases complexity of operations and increases maintenance. Reduces reliability and availability. May entrain air in fuel. Cooling effect of expanding air may cause localized freezing of fuel.

AFSSP

ALTERNATIVE 3b

Compressed Gas Pumping

1. Components similar to FSSP and able to operate at -60°F except that pumping is accomplished by compressed gas stored for that purpose.
2. Compressed gas is generated by igniting a solid propellant and stored in a separate tank. The compressed gas pumps fuel from a redundant accumulator tank system at 600 GPM to the dispensing components. The accumulators are recharged with fuel at low rates by compressed gas expelling fuel from the storage tanks to the accumulators when the system is not in the dispensing mode.
3. Two 600 GPM filter/separator units.
4. Six to twelve 10,000 gallon collapsible fuel storage tanks.
5. Approximately 2,400 feet of flexible hoses with valves, fittings, seals and gaskets and bulk transfer fuel manifolds.
6. Six liquid-transfer loading standards for bulk loading, two 500 gallon drum filling points, and six refueling points for filling vehicle fuel tanks, 55 gallon drums, and 5 gallon cans.
7. Storage tanks to be resupplied by bulk carrier means from the rear.

Advantages/Disadvantages

Deletes requirement for conventional pump and pump drive system.  
Increases complexity of operations and increases maintenance.  
Reduces reliability. May entrain gas in fuel. May cause local freezing of fuel due to cooling effect of expanding gas.

AFSSP  
ALTERNATIVE 4  
Inflatable Shelter

1. Pump and pump drive and filter/separator assemblies receiving special treatment (see paragraph 8 below). Other components up-graded to -60°F capabilities and employed in open, unprotected status.
2. Two 600 GPM pump assemblies with 50 H.P. gas turbine engine drives.
3. Two 600 GPM filter/separator units.
4. Six to twelve 10,000 gallon collapsible fuel storage tanks.
5. Approximately 2,400 feet of flexible hoses with vales, fittings, seals and gaskets and bulk transfer fuel manifold.
6. Six liquid transfer loading standards for loading tank trucks and semi-trailers, two filling points for 500 gallon drums and six refueling points for filling vehicle fuel tanks, 55 gallon drums, and 5 gallon cans.
7. Storage tanks to be resupplied by pipeline or hoseline, tankers, railway tank cars, or tank trucks and semi-trailers.
8. Pump/pump drive and filter/separator assemblies placed within shelters (domes) fabricated on site. These would be inflatable double-walled domes with aluminized fabric for internal reflection within the space between walls and the space filled with foam. The area within the domes would be heated by vehicle exhausts, through heat exchangers, or by personnel heating systems used by operating personnel.

Advantages/Disadvantages

Increases reliability of starting and operating system, increases complexity of operations and time for set up. Increases capital costs.

AFSSP  
ALTERNATIVE 5  
Rigid Shelter

1. Pump and pump drive and filter/separator assemblies receiving special treatment (see paragraph 8 below). Other components up-graded to -60°F capabilities and employed in open, unprotected status.
2. Two 600 GPM pump assemblies with 50 H.P. gas turbine engine drives.
3. Two 600 GPM filter/separator units.
4. Six to twelve 10,000 gallon collapsible fuel storage tanks.
5. Approximately 2,400 feet of flexible hoses with valves, fittings, seals and gaskets and bulk transfer fuel manifold.
6. Six liquid transfer loading standards for loading tank trucks and semi-trailers, two filling points for 500 gallon drums and six refueling points for filling vehicle fuel tanks, 55 gallon drums, and 5 gallon cans.
7. Storage tanks to be resupplied by pipeline or hose line, tankers, railway tank cars, or tank trucks and semi-trailers.
8. Pump/pump drive and filter/separator assemblies to be mounted in covered 3/4 ton truck bed, 3/4 ton trailer or skid mounted containers which is kept heated by a battery supply or other sources. The battery supply would be recharged by ground vehicle or helicopter electrical systems periodically.

Advantages/Disadvantages

Increases ease of starting and operating system, decreases development costs of key components. Decreases system reliability and increases complexity of operations. Decreases transportability.

AFSSP

ALTERNATIVE 6a

Truck Tankers

1. All components housed on truck tankers containing up to 5,000 gallon fuel storage, pump/pump drive units, fuel filter/separators, and hoses on reels.
2. 200 GPM pump/pump drive assembly.
3. 200 GPM fuel filter/separator assembly.
4. Two flexible hoses on reels with nozzles to refuel helicopters, 500 gallon drums, 55 gallon drums, 5 gallon cans and other bulk carriers.
5. Several truck tankers at a site will make up the AFSSP.
6. AFSSP resupply will be by bulk carrier means from the rear or by replacement truck tankers.

Advantages/Disadvantages

Increases flexibility of employment and military security of operations. Increases capital costs, decreases rate of refueling or supplying bulk fuel. Decreases air transportability. Increases operator efficiency.

AFSSP  
ALTERNATIVE 6b  
Helicopter Tankers

1. All components for half of an AFSSP system mounted in a helicopter dedicated as a tanker and two such helicopters constituting a completely mobile AFSSP.
2. Each helicopter has one 600 GPM pump with power take-off drive from the helicopter system.
3. Each helicopter has one 600 GPM fuel filter/separator.
4. Fuel storage tanks contained within each helicopter - one, two, or three 500 gallon containers depending on payload of the helicopter.
5. Flexible hoses on reels mounted in each helicopter, approximately 1200 feet of hose with valves and fittings per helicopter.
6. Each helicopter having one dispensing point for refueling 500 gallon drums and up to three dispensing points for 5 gallon cans and 55 gallon drums.
7. Resupply of AFSSP helicopters done by bulk carrier means from the rear.

Advantages/Disadvantages

Increases air transportability and reliability of system components. Decreases flexibility of operations and bulk storage capacity unless a substantial helicopter fleet is maintained which, in turn, increases capital costs. Decreases flexibility in dispensing operations. Increases safety risks to operators.

AFSSP

ALTERNATIVE 6c

Components Except Storage Tanks Mounted on Truck or Trailer

1. All components mounted on a truck except the fuel storage tanks. One half of AFSSP system components will be mounted on one truck, therefore, two trucks per AFSSP.
2. One 600 GPM pump/pump drive assembly per truck.
3. One 600 GPM fuel filter/separator per truck.
4. Total of six to twelve 10,000 gallon collapsible tanks placed on ground and connected by manifolds as required.
5. Hoses on reels with valves and fittings on truck.
6. One bulk loading hose and dispenser, one 500 gallon drum filler hose, and one 5 gallon can filler hose per truck.
7. AFSSP resupplied by bulk carrier means from the rear.

Advantages/Disadvantages

Increases reliability of components and operations. Increases capital costs, decreases air transportability. Increases operator efficiency.

AFSSP

ALTERNATIVE 6d

COMPONENTS EXCEPT STORAGE TANKS ON HELICOPTERS

1. All components mounted on a helicopter dedicated to that mission except the fuel storage tanks. One half of AFSSP system components will be mounted on one helicopter, therefore, two helicopters per AFSSP.
2. One 600 GPM pump/pump drive assembly per helicopter.
3. One 600 GPM fuel filter/separator per helicopter.
4. Total of six to twelve 10,000 gallon collapsible tanks placed on ground and connected by manifolds as required.
5. Hoses on reels with valves and fittings on helicopter.
6. One bulk loading hose and dispenser, one 500 gallon drum filler hose, and one 5 gallon can filler hose per helicopter.
7. AFSSP resupplied by bulk carrier means from the rear.

Advantages/Disadvantages

Increases reliability of components and operations. Increases capital costs and decreases flexibility in dispensing operations. Increases operations turn-around time. Increases air transportability.

AFSSP

ALTERNATIVE 7

Recirculation

1. Pump and pump drive and filter/separator assemblies receiving special treatment (see paragraph 8 below). Other components up-graded to -60°F capabilities and employed in open, unprotected status.
2. Two 600 GPM pump assemblies with 50 H.P. gas turbine engine drives.
3. Two 600 GPM filter/separator units.
4. Six to twelve 10,000 gallon collapsible fuel storage tanks.
5. Approximately 2,400 feet of flexible rubber compound hoses with valves, fittings, seals and gaskets and bulk transfer fuel manifold.
6. Six liquid transfer loading standards for loading tank trucks and semi-trailers, two filling points for 500 gallon drums and six refueling points for filling vehicle fuel tanks, 55 gallon drums, and 5 gallon cans.
7. Storage tanks to be resupplied by pipeline or hoseline, tankers, railway tank cars, or tank trucks and semi-trailers.
8. Pumps, filter/separators, valving, hose lines and fittings kept operable by almost continuous low rate recirculating of fuel through the system when system is not dispensing fuel. Pump drive system to be kept running continuously during cold temperature extremes but can be shut down when temperatures rise sufficiently.

Advantages/Disadvantages

Increases system operations reliability. Increases operating costs and complexity of operations. Increases capital costs slightly.

AFSSP

ALTERNATIVE 8a

Selected Components Mounted on Vehicles Being Refueled

1. All separate components as listed below capable of operating at -60°F unprotected. Pump/pump drive and filter/separator assemblies mounted as standard equipment on all vehicles using standard military fuels.
2. Ground vehicles have one 10 GPM pump with electrical motor drive from vehicle system and an internal means to refill spare fuel drums carried on board. Helicopters have one 50 GPM pump/pump drive assembly mounted on board.
3. Ground vehicles utilize fuel filters which are currently a part of their fuel feed system. Helicopters to have one 50 GPM fuel filter/separator mounted on board.
4. Six to twelve 10,000 gallon collapsible fuel storage tanks.
5. Approximately 2400 feet of flexible hoses with valves, fittings, seals and gaskets, and bulk transfer fuel manifold.
6. Six bulk loading standards, two 500 gallon drum fill points, and six 55 gallon drum and 5 gallon can refill points.
7. Storage tanks to be resupplied by bulk carrier means from the rear. AFSSP's can load bulk fuel carriers by using pump drives and filter/separators mounted on the bulk carriers (50 GPM probable max.).

Advantages/Disadvantages

Increases system reliability, increases turn-around rate. Increases capital costs significantly.

AFSSP

ALTERNATIVE 8b

Power Take-Off Drive Systems on Refueled Vehicles

1. All separate components as listed below capable of operating at  $-60^{\circ}\text{F}$ . Air transportable and not vehicle mounted.
2. Two 600 GPM pump assemblies driven by mechanical power take-off from aircraft and vehicles, i.e., from winches mounted or to be mounted on all vehicles, etc.
3. Two 600 GPM fuel filter/separators.
4. Six to twelve 10,000 gallon collapsible fuel storage tanks.
5. Approximately 2400 feet of flexible hose with valves, fittings, seals and gaskets, and bulk transfer fuel manifold.
6. Six liquid-transfer loading standards for loading tank trucks and semitrailers, two filling points for 500 gallon drums, and six refueling points for filling vehicle fuel tanks, 55 gallon drums, and 5 gallon cans.
7. Storage tanks to be resupplied by pipeline or hoseline, tankers, railway tank cars or tank trucks and semitrailers.

Advantages/Disadvantages

Increases reliability of operation but increases capital costs significantly and increases complexity of operations.

AFSSP  
ALTERNATIVE 9  
Advanced Sources of Energy

1. All components similar to FSSP upgraded to operate at -60°F excepting pump drive units which would utilize unusual energy sources.
2. Two 600 GPM pumps. Pump drives could make use of:
  - a. Atomic energy
  - b. Microwave energy
  - c. Wind power energy
  - d. Solar energy
3. Two 600 GPM fuel filter/separator assemblies.
4. Six to twelve 10,000 gallon collapsible fuel storage tanks.
5. Approximately 2,400 feet of flexible hose with valves, fittings, seals and gaskets.
6. Six bulk loading standards, two 500 gallon drum refueling points, and six 55 gallon drum or 5 gallon can refilling points.
7. Resupply of AFSSP by bulk carrier means from the rear area.

Advantages/Disadvantages

Increases development risks and costs sharply. Increases maintenance costs and complexity of operations. May decrease operations costs. Decreases air transportability.

AFSSP

ALTERNATIVE 10

Use of Rigid Fuel Storage Tanks

1. System components similar to FSSP upgraded to be operable at  $-60^{\circ}\text{F}$  excepting all fuel storage tanks which will be rigid, non collapsible, tanks.
2. Two 600 GPM pumps with gas-turbine engine drives.
3. Two 600 GPM fuel filter/separator assemblies.
4. Six to twelve 10,000 gallon rigid fuel storage tanks. These tanks to be mounted on trucks or on flat bed trailers and transported empty to and parked on AFSSP sites. They will be filled on site.
5. Approximately 2,400 feet of flexible hose with valves, fittings, seals, and gaskets and bulk transfer fuel manifold.
6. Six bulk fuel loading standards, two refueling points for 500 gallon drums, and six refilling points for 55 gallon drums and 5 gallon cans.
7. Fuel storage tanks to be resupplied by bulk carrier means from the rear areas.

Advantages/Disadvantages

Decrease development of collapsible tank risks and costs. Increases reliability of operations. Decreases air transportability and increases capital costs greatly.

FIGURE 3-1

SCHEMATIC DIAGRAM OF AFARE SYSTEM  
(All Components Exposed)

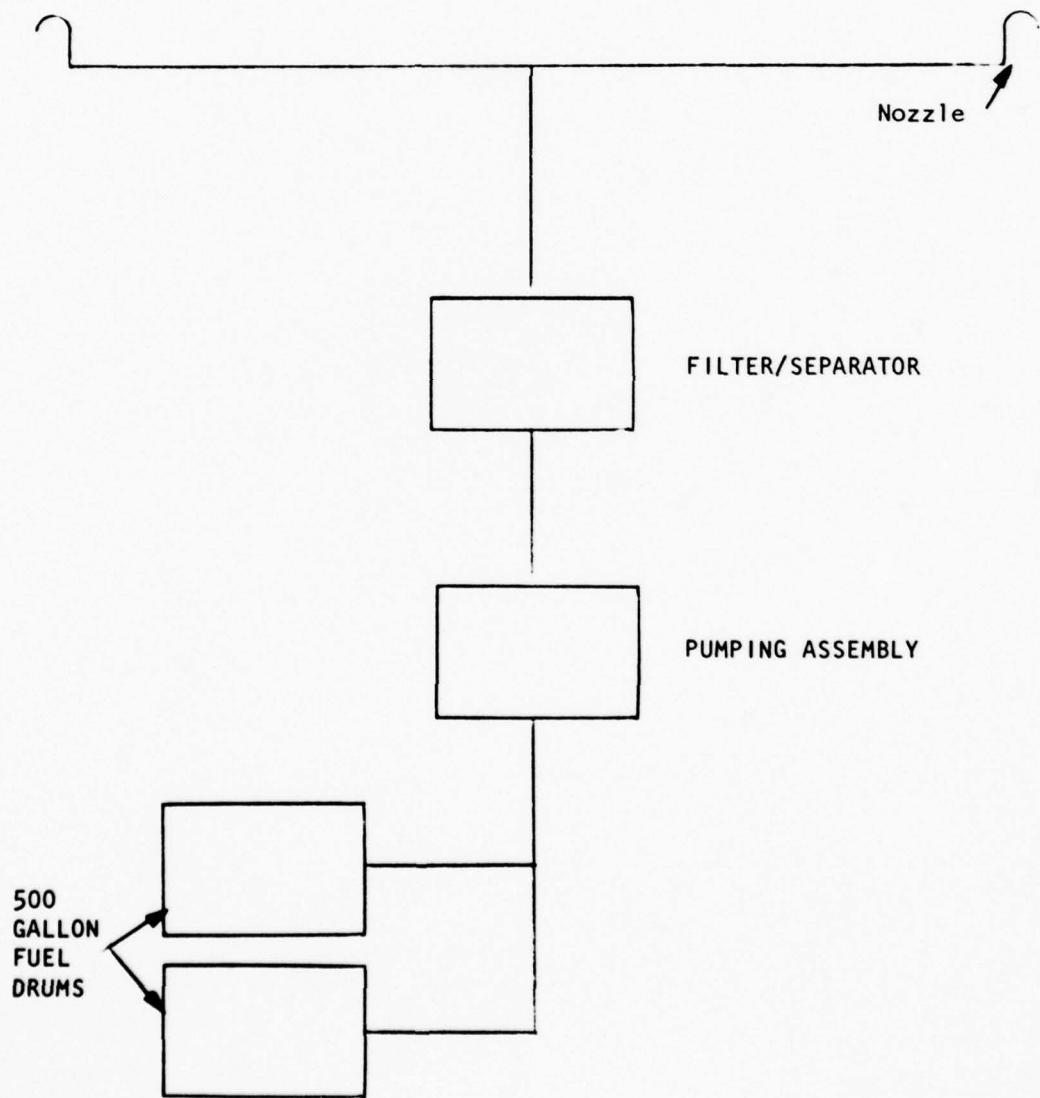

FIGURE 3-2  
SCHEMATIC DIAGRAM OF SINGLE PRODUCT AFSSP  
DISPENSING SYSTEM

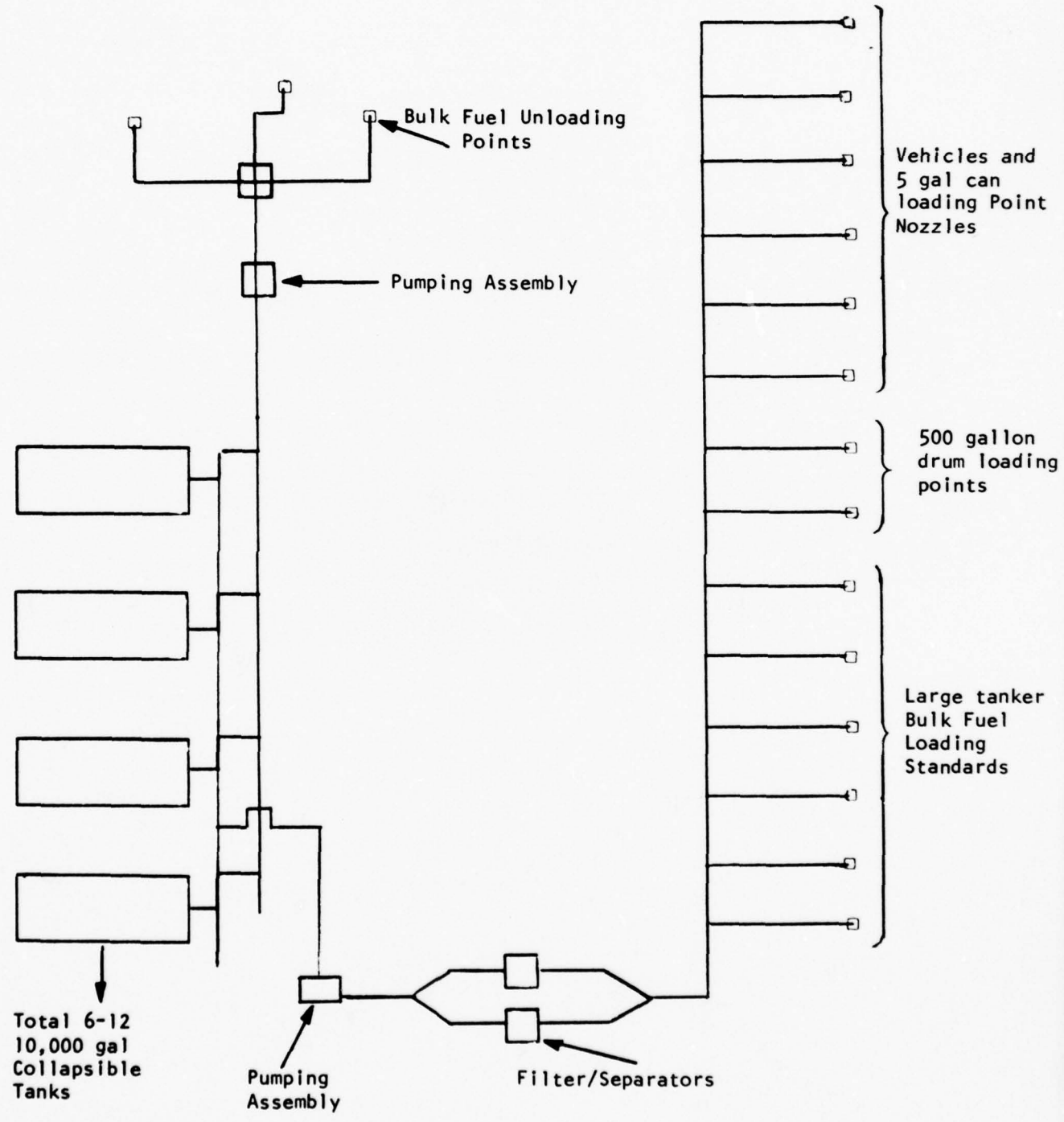

FIGURE 3-3  
 SCHEMATIC DIAGRAM OF FUEL PRODUCT DISPENSING AFSSP SYSTEM

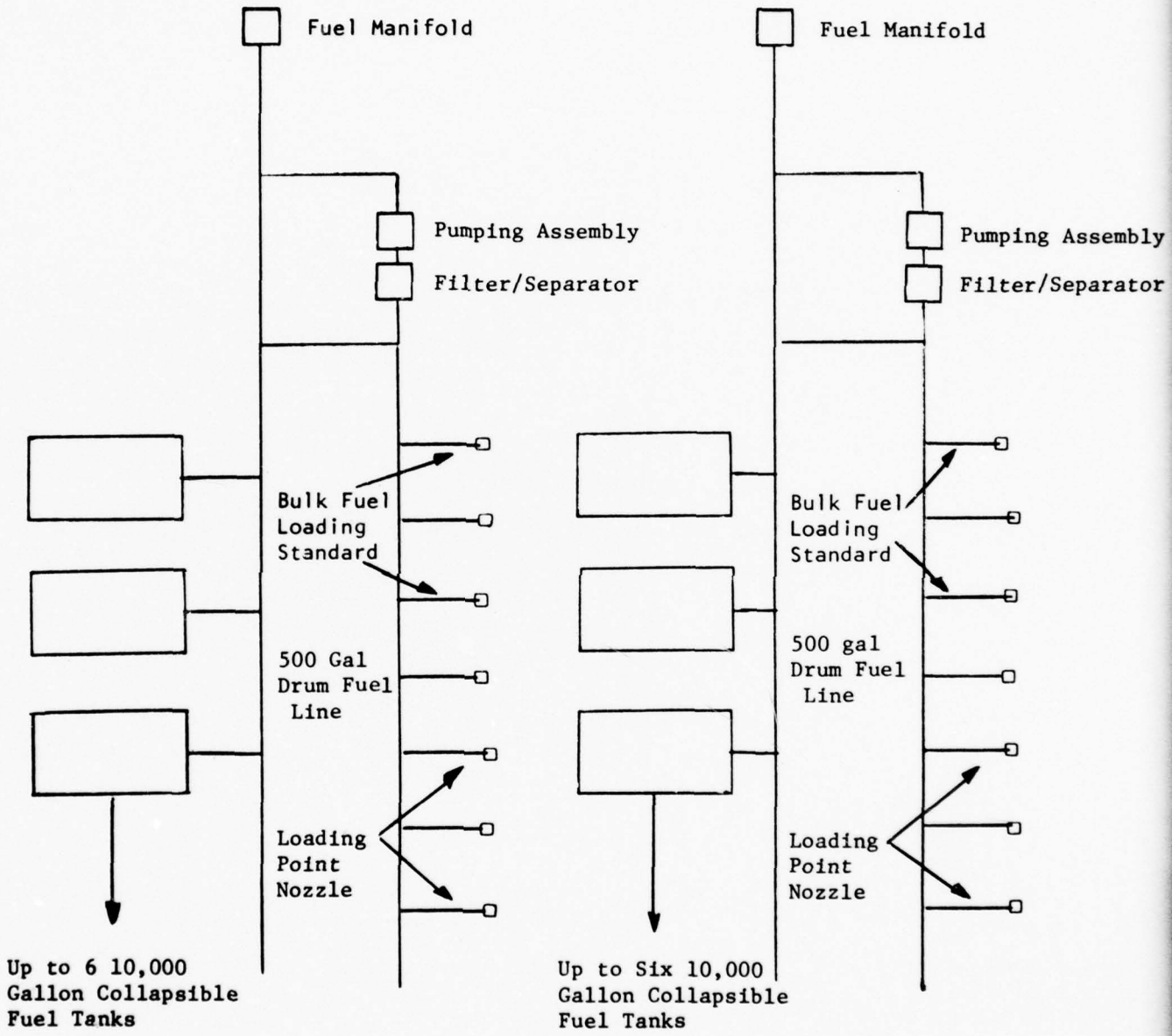
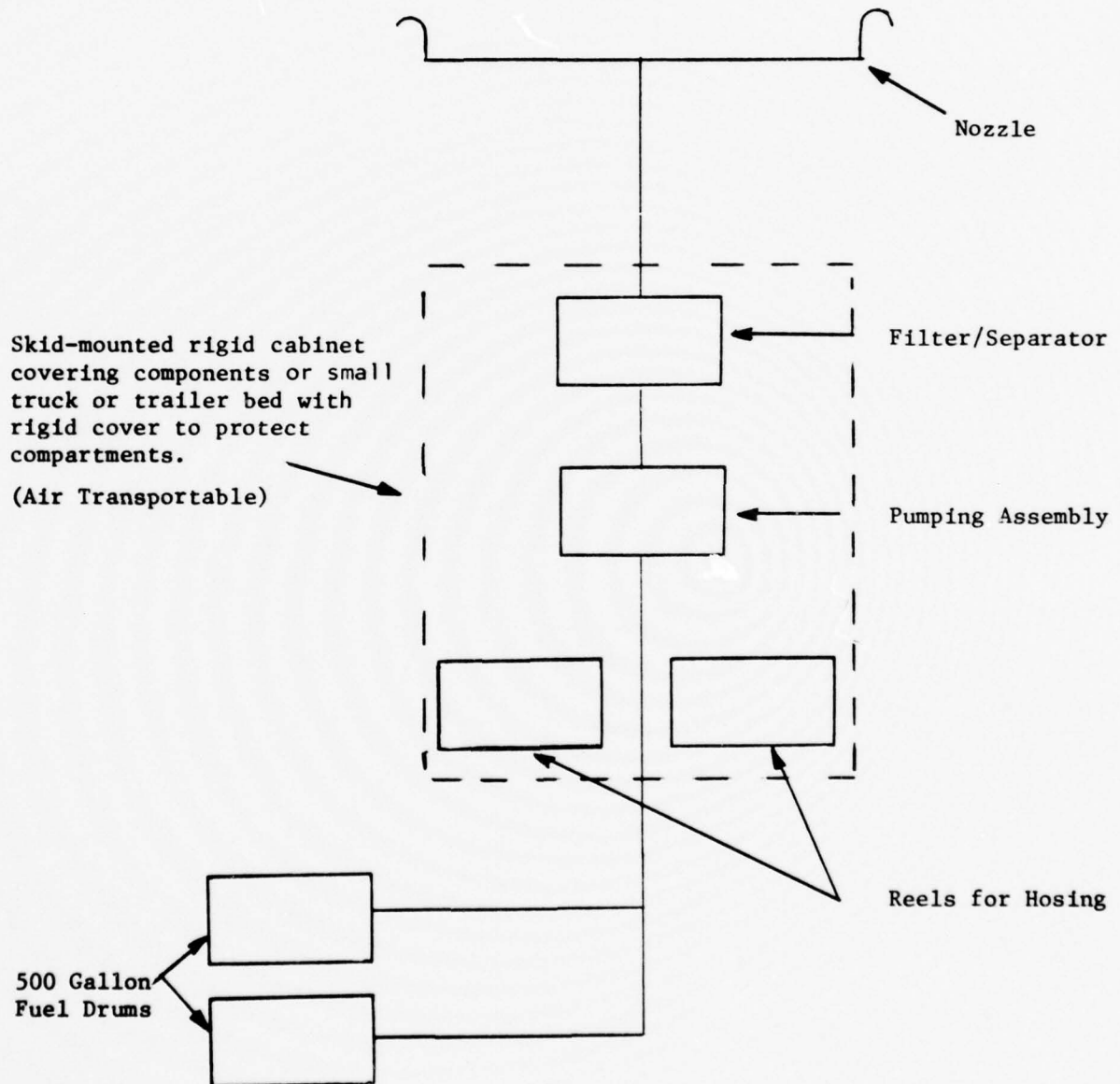

FIGURE 3-4  
SCHEMATIC DIAGRAM OF AFARE SYSTEM WITH RIGID SHELTERS



## CHAPTER 4 - PRELIMINARY STATE-OF-THE-ART RESEARCH

### 4.1 INTRODUCTION

In order to perform the first phase evaluation of the various systems, preliminary information, without detailed feasibility data, was needed on:

- hosing and pipe components
- seals
- collapsible fuel storage tanks
- pumps and alternatives
- pump drives
- shelters
- other components
- current cold weather operating practices

A great deal of this information was readily available, but to supplement this, some preliminary state-of-the-art research was necessary. This research was divided into three areas:

- current cold weather practices and technology
- current availability of drives, particularly turbines and diesel
- solid propellents and accumulators

Research in these three areas is presented in this chapter. Research in elastomerics and cold weather batteries was also performed, but these two areas were not needed until the final evaluation, and in addition, represented the two areas where future development is of extreme importance. For these reasons, most of the research and state-of-the-art for batteries and elastomerics are presented in Chapter 6.

A complete listing of information sources for this study is presented in Appendix 2. One of the principal early research activities was an ADL field trip which included visits to: The U.S. Army Cold Regions Test Center, Fort Greeley, Alaska; the 222nd U.S. Army Aviation Battalion, Fort Wainwright, Alaska; the U.S. Army Combat Developments Activity, Alaska, and the 173rd Infantry Brigade both at Fort Richardson, Alaska; the U.S. (Navy) Support Forces Antarctica and Naval Civil Engineering Laboratories both at Port Hueneme, California; and the home office of the Antarctic Support Division of Holmes & Narver, Inc., Orange, California, the operating contractor for the various bases of the National Science Foundation in the Antarctic. Also included in this trip were visits to and conversations with several bulk petroleum and commercial

fuel dispensing equipment suppliers, contractors, and Alaskan Airlines in Alaska. Much information was obtained regarding current cold weather practices and technology.

Extensive information was gained from MERADCOM and equipment manufacturers on the availability of gas turbine engines and diesel engines which would be suitable for arctic fuel dispensing pump drive units. Arthur D. Little also received in some detail information regarding solid propellents as an energy source for use in an innovative pump drive concept alternative. Information from all of these areas is presented in this chapter.

#### 4.2 CURRENT COLD WEATHER PRACTICES AND TECHNOLOGY

The U.S. Army cannot operate effectively in remote areas of the arctic where tactical helicopter operations are required and where there are no roads or airfields within satisfactory range for effective helicopter operations. The principal reason is that the current FARE and FSSP systems cannot operate at temperatures below  $-25^{\circ}\text{F}$ . Some details of a number of cold-induced problems are described in later paragraphs of this section, but the major problems immediately follow: All the elastomeric components cause trouble, especially, collapsible discharge hoses and the collapsible drums (bags) and tanks which become brittle and crack at temperatures below  $-25^{\circ}\text{F}$  (with the exception of 10,000 gallon tanks to some extent.) Additionally, the unvented 500 gallon collapsible drums will only partially collapse at  $-60^{\circ}\text{F}$ . Current Army practice is to set up 5-point or 10-point refueling stations for arctic tactical helicopter operations using the FSSP 350 GPM components and 4 inch suction (reinforced) hoses and 5,000 gallon fuel tanker trucks as the bulk storage containers. These refueling stations must, therefore, be accessible by road. A feasible alternative also in use employs temporary airfields, either makeshift as on frozen lakes, or at existing and abandoned air strips, to set up the 10-point refueling system using the current 350 GPM components and the 10,000 gallon collapsible tanks for supply point fuel storage. These tanks must be spread out, emplaced, and filled warm (above  $-20^{\circ}\text{F}$ ). Once in use, they will operate satisfactorily down to  $-60^{\circ}\text{F}$ . Bulk refueling of these stations is accomplished by using C-130 aircraft bladder birds.

- Fuels

The various fuels used in the arctic evidence no increase in viscosities at temperatures down to  $-60^{\circ}\text{F}$ . These fuels include MOGAS, Diesel Fuel Arctic, JP-4, and JP-5. Fuel filtering is still required, however, regular diesel fuel will experience coagulation of parafins at low temperatures which will precipitate out and clog fuel filter/separators.

- Pumps

Centrifugal pumps are considered the most satisfactory type for extreme cold weather use. They are rugged and provide the steady higher pressure required. Rotary vane pumps experience breakdown

at very cold temperatures due to brittle fracture of the vane blades. Reciprocating pumps are heavy and expensive. Other special pumps such as peristaltic and scroll pumps would not perform satisfactorily at very cold temperatures. Pumps of 200 and 600 GPM capacity appear feasible for AFARE's and AFSSP's respectively

- Pump Drive Equipment

Gasoline engine pump drives are reputed generally to be unsatisfactory at  $-60^{\circ}\text{F}$ . They are very difficult to start and once started, experience continuous shut down problems when running in the open at temperatures down to  $-60^{\circ}\text{F}$ .

Diesel engine drive units are difficult to start from a cold soak condition, but once started, they operate well. They are heavier than other drive units but are rugged and have proven reliability. Further discussion on diesel engines is presented later in this chapter.

Gas turbine engine units appear to have many advantages. They require either battery ignition of air motor starting mechanisms. They are lighter than most other drive units and are highly desirable for AFARE subsystems in that they burn multiple fuels. They can therefore use the same fuel for burning as is being dispensed by the system. These type units are used in helicopter auxiliary power units (APU's) and work satisfactorily in the arctic. Applications for the fuel dispensing systems, however, have not been developed and therefore have not been tested in the arctic. Further discussion on gas turbine engines is presented later in this chapter.

Electric motor use at  $-60^{\circ}\text{F}$  is reported to be somewhat undesirable due apparently to moisture freezing in the mechanism on the next start up. These motors need an electrical power source.

- Fuel Filter/Separator Units

U.S. Army personnel in Alaska stated that they experienced no operational problems with the 350 GPM fuel filter/separator (F/S) units at temperatures of  $-60^{\circ}\text{F}$ . Those operators, however, had not tested the fuel quality before and after passing it through the units and the fuel presumably has been quite clean. The operators stated, however, that the F/S equipment must be carefully maintained, that they prefer field maintainable filter elements over throw away elements, and that the larger F/S units should be wheel-mounted for ease in positioning in the field when full. References listed in Item No. 7, Appendix 2 regarding arctic testing in 1967 of the 350 GPM F/S down to  $-56^{\circ}\text{F}$  and the 50 GPM F/S down to  $-50^{\circ}\text{F}$  stated that the units were considered

suitable for U.S. Army use in an arctic winter environment provided a heated area was made available to periodically thaw accumulated ice. These units passed only fuel meeting the requirement of MIL - F - 8901A at the above low temperatures. MERADCOM after years of research with F/S units, however, states emphatically that the current F/S equipment in the arctic is not designed to operate at temperatures of  $-60^{\circ}\text{F}$  and that this equipment at those low temperatures in fact does not effectively filter unclean fuels. MERADCOM states that satisfactory F/S units must be developed for arctic fuel dispensing equipment systems.

- Hoses

Current collapsible discharge hoses are unsatisfactory at  $-60^{\circ}\text{F}$  in that they become brittle and crack. The short suction hose lengths (these have reinforced construction) are satisfactory.

There are current off-the-shelf arctic hoses (e.g., Goodyear Flexwing) that according to the manufacturers remain flexible at  $-60^{\circ}\text{F}$  and can be rolled up on a reel. They will not collapse, however. These non-collapsible hoses are produced in diameter up to four inches. Production of collapsible hoses up to four inches in diameter had been done at one time on a special order basis by Goodyear for the Alaska pipeline project, according to one equipment supplier in Fairbanks, Alaska. In any case, minimum lengths (at least) of flexible hoses of appropriate material must be available in the portion of the fuel discharge hosing or piping close to the nozzles to enable fueling nozzles to be raised to the refueling ports on the vehicles at  $-60^{\circ}\text{F}$ .

- Seals and Gaskets

The standard Army seals and gaskets are unsatisfactory at  $-60^{\circ}\text{F}$ . They take on a permanent set when the systems are assembled at those temperatures and the slightest component movement often causes leakage. There are some commercial seals available under the commercial names Viton, Teflon, and Buna-N which reportedly are satisfactory in extremely cold temperatures. Phosphonitrilic fluoroelastomer, a semi-inorganic rubber (by Firestone), also appears well suited for these uses.

- Connections

The Army uses cam-lock quick disconnect connections which are very satisfactory, particularly for use by personnel wearing heavy arctic clothing and mittens.

- Metering Systems

Information is lacking on the availability of meters in the Army inventory which will work adequately and accurately in the fuel dispensing systems at -60°F temperatures. A commercial fuel oil distributor in Delta Junction, Alaska, however, states that the Brodie flow meters (measuring 65-200 GPM) in his system exposed to temperatures below -60°F have worked without problems for years. He used fuel oil level indicators with mechanical linkages to measure stored quantities in his fixed tanks. It appears reasonable to assume that satisfactory flow metering can be accomplished with current equipment if metering in new systems is desired.

- Pipeline Fittings and Accessories

There are no problems with gate valves in current systems nor with other fittings and connectors. The number of connections, and therefore potential leakage points, must be kept to a minimum.

- Nozzles

Problems with leakage in nozzles at -60°F is fairly extensive. Operators keep spares warm and trade-off with those in use. Closed circuit nozzles are best but are not generally in use for the light helicopters. Arctic seals and diaphragms in nozzles are not available yet, however, OPW supplies nozzles with teflon seals for the swivel connections of those nozzles, and this alleviates some of the problems.

- Collapsible Fuel Storage Containers

Rugged terrain, large trees, and poor pilot visibility from ice fog and from whirling snow caused by helicopter downwash on landing approaches make it desirable for the 500 gallon fuel drums being airlifted forward to resupply the AFARE's to be flexible to avoid rupture on fairly hard touchdown. However, current 500 gallon collapsible drums are unsatisfactory at -60°F, for they crack at -40°F to -50°F. They are not vented and will not collapse fully at -60°F. The 10,000 gallon collapsible tanks, if in place and operational at -60°F, will operate satisfactorily. At -60°F, the Army cannot, however, take folded up 10,000 gallon collapsible tanks to a site, unfold them for use, and refold and move them to new sites when the tank material has not been warmed up. Without warming the tanks, they become too brittle and crack.

- Working with Helicopters

Helicopters generate a great deal of static electricity from the whirling blades when landing in extreme dry cold. Additionally, the blade downwash raises the wind chill factor greatly for per-

sonnel underneath. Hence, all helicopters are shutdown before refueling for safety considerations in the extreme cold. With the engines shutdown, exhaust heat cannot be obtained from helicopters for start-up energy sources as would be possible for wheeled vehicles. Helicopters also do not have mechanical power take-off capability as do some of the tactical wheeled vehicles.

With regard to customizing vehicles for refueling, attack helicopters and utility helicopters are heavily loaded with extra survival gear for the crew in extremely cold temperatures. Therefore, to attach components of fuel dispensing systems to helicopters as installed accessories would require redesign of the helicopters, resulting in large added development costs.

- Personnel Issues

It is axiomatic that the first priority the Army establishes in operations in extreme cold is for troops to establish warm shelters immediately in any location where they are not moving while performing their operations. Five-man or ten-man arctic tents and Yukon stoves are standard equipment for arctic shelters. Accordingly, should Army doctrine require that all AFARE's and AFSSP's deployed for operations be manned at all times, warm personnel shelters will be available for protecting batteries and other components which would become ineffective when not in active use. This could be an alternative consideration to providing batteries and other components which will remain fully effective at temperatures down to  $-60^{\circ}\text{F}$ .

With regard to working in the extreme cold, operators and maintenance personnel take three to four times longer to perform operations at  $-60^{\circ}\text{F}$  than at normal temperatures. Furthermore, petroleum arctic mittens are not currently available for  $-60^{\circ}\text{F}$  temperatures, and they are vitally needed.

- Transportability Issues

Inasmuch as military operations may be in areas without roads and in deep snow, operations may have to be conducted by personnel using snow shoes, skis, and helicopters. AFARE equipment and fuel resupply drums must be transportable by helicopters.

In addition, due to limited roads in the arctic, AFSSP's must be air transportable to required locations and must be capable of receiving bulk resupply by air (as well as from other means at other locations having road and rail networks).

- Tactical Vulnerability Issues

Tactical security for the current Army fuel dispensing systems is obtained principally by passive measures. These include dispersion and camouflage of the operating supply points whenever possible. In the arctic, some of the components are painted in the standard alternating white and olive drab irregular patterns. Camouflage nets are also used. Dispersion and camouflage of AFSSP locations should be somewhat easier inasmuch as direct helicopter refueling operations would be minimized and these points would probably be more fixed than AFARE's. Such passive protective measures would be somewhat ineffective for AFARE's since their general locations would be disclosed by continuous helicopter refueling operations during heightened military activity. It would appear that AFARE's would have to be relocated frequently in forward areas for security from enemy countermeasures.

There appears to be no protection for these fuel dispensing systems from detection by infrared (IR) radiation equipment or by the noise that the pump drive equipment generates in operation. Security from direct enemy attack and from pilferage or sabotage would have to be performed by local security forces. There is no protection for the systems from enemy exploding munitions other than from dispersion and physical barriers found in the local terrain features. Burial or digging in the components is extremely difficult in the frozen conditions at low arctic temperatures.

- Other Operational Considerations Using Current Technology

An additional cold weather problem is nozzle blowback. Excessive fuel line pressures in the dispensing systems must be avoided to prevent nozzle blowback in the operators hands when refueling helicopters. Blowback may cause operators to spray fuel up at the helicopter hot exhaust parts and result in fire and explosion. Cold stiffened flexible fuel lines leading to the nozzles compound this problem.

As for heating possibilities, much use is made of Herman-Nelson portable heaters to warm equipment for start-up. Swingfire portable heaters are new items which have been tested in the arctic, are satisfactory, and highly regarded. Such equipment is very slow to start-up from cold soak conditions.

With regards for alternative approaches, designs using compressed air and exhaust energy sources must consider severe freeze up problems from water vapor.

A final problem is the static electric problem alluded to in the discussion of helicopters. Fuel dispensing systems and vehicles being refueled must be grounded, and this is difficult in the winter extremes.

One can draw several conclusions given the present practices in the arctic. The current proposed AFARE concept is difficult to implement for remote operation. Furthermore, elastomerics pose a severe problem. On the other hand, gas-turbine pump drives offer a great deal of promise, and 200 and 600 GPM pumps appear feasible for AFARE and AFSSP respectively.

#### 4.3 GAS TURBINE ENGINES FOR PUMP DRIVES

In view of the promise of gas turbine engines, Arthur D. Little, Inc. conducted a research of the availability and performance of suitable gas turbine engines (GTE) to serve as prime movers for the arctic fuel dispensing systems. GTE's made by Solar Turbines International and by The Garrett Corporation were investigated and descriptions and specifications are attached as Appendix 3.

Applicable units investigated were:

AFSSP (600 GPM pump) - Solar Titan T-32, 150 HP  
Garrett GTP 36-51, 75 HP

AFARE (200 GPM pump) - Solar Gemini, 27 HP  
Garrett GTP 30-67, 32 HP

Additionally there appears to be a 47 HP version of the Solar Gemini and a 42 HP version of the Garrett GTP 30-67. The major conclusions follow:

Except for the Garrett GTP 36-51, which has been integrated for a prototype with a pump, these units are all used currently with a generator or an alternator as portable electric power plants. The Garrett GTP 36-51 has optional gearboxes which can supply a variety of output shaft speeds for integration with a pump. The Garrett GTP 30-67 has an optional gearbox for a 3600 RPM output which might be suitable. The Solar Gemini drives a 3600 RPM generator in one version, and therefore, a gearbox is available at that speed. The Solar Titan output speed, however, is evidently 6,000 RPM, which may be high for convenient integration with suitable pumps.

Small quantity prices are estimated to be:

Solar Gemini with 3600 RPM generator	- \$60,000 - \$70,000
Solar Titan without generator or gearbox	- \$20,000 - \$25,000
Garrett GTP 36-51, turbine and gearbox	- \$25,000
Garrett GTP 30-67, turbine alone	- \$23,000 - \$24,000

The sizes of the units are shown on the specification sheets in Appendix 3. Weights range from 89 lbs. to 900 lbs., the upper end including considerable generating hardware. For the single case where the turbine and gearbox alone are shown, i.e., the Garrett GTP 36-51, this combination has a weight of 370 lbs.

All of these units have an electric starter which operates from a 24 VDC battery supply (e.g., two 45 amp-hour batteries in series). The GTE's have all been tested and/or qualified for starting at temperatures between  $-65^{\circ}\text{F}$  and  $+130^{\circ}\text{F}$ . The Solar units cite a 30-second start throughout this temperature range. For operations at  $-60^{\circ}\text{F}$ , the batteries should be the type that will be fully functional at those low temperatures. (Batteries for cold weather operations are discussed in Chapter 6. An alternate starting system using pressurized dry nitrogen and an air starting motor for the GTE's is also discussed in Chapter 6.)

All of the above gas turbine engines can operate on all four of the fuels of interest in arctic operations, however, leaded gasoline should not be used if possible or used only in case of emergency due to its corrosive effect on the turbines.

Air-cooled diesel engines of the sizes required for these applications are also readily available and these, as well as others, were evaluated. A comparison of the various engines are presented in the first phase evaluation, Chapter 5.

#### 4.4 SOLID PROPELLENTS AND ACCUMULATORS

One of the alternative arctic fuel dispensing system configurations developed during this study was the replacement of the conventional pump and pump drive units with a system involving the generation of a compressed gas by ignition of a solid propellant. This compressed gas would pump fuel by means of a set of accumulators. A sketch of such a system is shown on Figure 4-1. There would be several fuel accumulators so that the empty ones would be recharged with fuel from the storage tanks as fuel was being pumped out of others during dispensing operations. Some initial research was conducted for this type of alternative to assess its feasibility. Investigation of solid propellents to generate compressed gas for this dispensing scenario revealed that such propellents are available for producing non-toxic gases. Atlantic Research Corporation (ARC), Gainesville, Virginia, is one manufacturer. These propellents have been produced for use in passive restraint devices for the automobile industry. Principal gases produced by one type of propellant are water, carbon dioxide, and oxygen (another type not made by ARC is available which does not generate water). The major solid component of the type propellant investigated is potassium chloride and all chemicals used in making the propellents are readily available.

As a rough example of materials and equipment required for this compressed gas/accumulator system, we will use a requirement to dispense 100 gallons of fuel at a pressure of 150 psig as our base. This will produce the required head of about 350 feet for AFARE. We are assuming that carbon dioxide and oxygen are available as working fluids since water will condense out at low arctic temperatures. This mixture would be 76% carbon dioxide and 24% oxygen.

Referring to the system shown in Figure 4-1 the gas generator cartridge would operate at about 2,000 psi and would pressurize a 2.5 cubic feet gas accumulator volume up to 200 psig. Gas would be bled from the gas accumulator and regulated to 150 psig to displace fuel from the fuel accumulator. About 18 lbs of gas are required to do this and this gas weight would be produced by a propellant mass of about 51 lbs. The propellant would be in the form of a solid cylinder about 5 inches in diameter and 47 inches long. It would be wrapped with an inhibitor so that it would burn on one end like a cigarette. At  $-60^{\circ}\text{F}$ , it would burn about 54 seconds. Thus, two such gas generators would have to operate at all times to produce an average flow of fuel of 200 GPM. Presumably, this could be achieved by four or more parallel gas accumulator/fuel accumulator systems arranged so that at least two were pumping at all times while the others were filling with fuel and being recharged with propellant cartridges. In sufficient quantities, the propellant cartridges are estimated to cost about \$150 and the percussion igniters about \$1. Since each cartridge pumps 100 gallons of fuel, the pumping cost per gallon is \$1.50. An advantage to this pumping system is that the energy source is independent of the fuel being dispensed by the system and solid propellents have been developed by industry.

Though the use of compressed gas generated by burning solid propellents to pump fuel from an AFARE or AFSSP system appears feasible, there appear to be severe penalties associated with the planned use of this system. First, the pumping costs are very high. Second, the development time and costs may be high in the areas of solid propellant ignition procedures for arctic field use, fuel transfer procedures from the storage tanks to the fuel accumulators, gas cooling procedures in the gas accumulator following initial generation, gas scrubbing procedures to remove combustion particles after ignition, and possibly compressed gas/liquid fuel separation procedures before the fuel enters vehicle fuel tanks. Third, the system may be virtually impossible to design for effective automatic, unattended operation. Fourth, component maintenance requirements may be excessive and costly, particularly for the gas scrubbing/gas accumulator equipment. Fifth, the large numbers of components may penalize the system in meeting system volume and weight criteria. Sixth, the system would require machinery to load the solid propellant cartridges at rates of two per minute or would require quick manual reaction by operating personnel, all of which lowers the system reliability. The evaluation of the system is presented in the next chapter.

FIGURE 4-1

SOLID PROPELLANT GAS PRESSURIZATION SYSTEM FOR FUEL DISPENSING

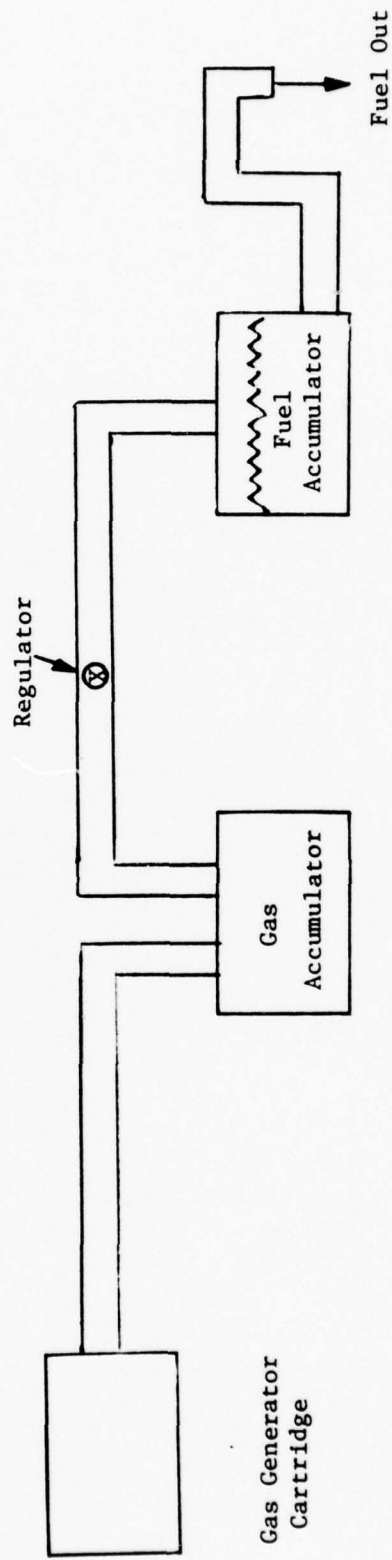

## CHAPTER 5 - FIRST PHASE EVALUATION

### 5.1 INTRODUCTION

This chapter presents the results of the first phase evaluation of the various alternatives tabulated in Chapter 3. The purposes of this preliminary evaluation were:

- to eliminate from further considerations those alternatives that fall far short of fulfilling the mission objectives;
- to reduce the number of candidate systems to a much smaller set on which a more detailed evaluation can be carried out;
- to discover the evaluation criteria with high discriminatory power and to eliminate criteria that do not effectively discriminate among alternatives;
- to find out where more research and analysis must be carried out to gather more information or to refine the comparison methodology so that the next evaluation phase can be carried out.

In the preliminary evaluation it was important to recognize concepts whose performance is high, even though their development risks, after an initial examination, appeared also to be high. An example of such a system was the baseline system proposed by MERADCOM (Alternative 1). Prior to a systematic evaluation of all the alternatives, we qualitatively rated the baseline system with respect to the initial set of attributes. The variant considered has a gas turbine drive and a centrifugal pump. The qualitative evaluation presented in Section 5.2 demonstrated several things. First, it demonstrated the importance of development risk; second, it demonstrated that the baseline system had excellent potential; and third, it emphasized the importance of a flexible and easy to use system.

After the preliminary evaluation of the baseline system, all of the initial candidate systems were systematically evaluated. When alternatives that fall far short of mission performance requirements were eliminated, the only alternatives left were variations of the baseline system. Various options included hosing, type of drive (gas turbine or diesel) existence of a shelter, and type of starting system.

The organization of the chapter is as follows: Section 5.2 presents the preliminary evaluation of the baseline system, Section 5.3 presents the steps in the evaluation, Section 5.4 presents the attribute refinement, Section 5.5 presents the decomposition of alternatives, and Section 5.6 presents the scoring methodology. In Section 5.7 the scoring results are presented along with the alternatives selected by the evaluation procedure.

## 5.2 PRELIMINARY EVALUATION OF STANDARD BASELINE SYSTEM

In this section we present a preliminary evaluation of the attributes of the baseline system. The subalternative considered is a centrifugal pump with a gas turbine drive. The other subsystems will result in similar evaluations for many of the attributes. The sample evaluation below is geared for the AFARE system. AFSSP evaluation will be similar.

A system concept diagram of the concept is depicted below:

FIGURE 5-1

DIAGRAM OF CONCEPT 1 FOR AFARE WITH CENTRIFUGAL PUMP AND GAS TURBINE ENGINE

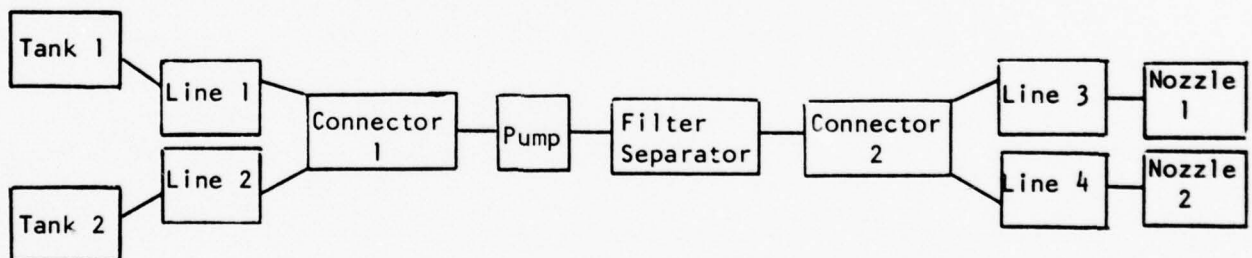

Each of the components of the system is depicted by a box with the name of the component within the box. Reliability or availability of the system can then be calculated in terms of the reliability and availability of each of the individual components.

The evaluation of each of the attributes is evaluated as follows:

1. Performance

- Capability of meeting requirements - high
- Filling rates - 200 (GPM)
- System turnaround speed for fuel off-loading - fast
- System turnaround speed for refueling - fast
- Fuel flexibility - high

2. Availability - Reliability

- Nozzles - Close to 1
- Hoses - availability of 0.9 - hoses are more vulnerable when the system is idle and the fuel is not flowing through it
- Filter - Moderate
- Pump - availability and reliability is moderate to high
- Tanks - availability and reliability is moderate to high

3. Development Risk

- Probability of implementation using current technologies within
  - 1982 - low
  - 1985 - moderate
  - 1988 - moderate to high
- Probability of developing components within time period:
  - a. Hoses - high
  - b. Filter - moderate
  - c. Pump and Drive - high
  - d. Seals - high
  - e. Drums - moderate
  - f. Nozzles - high
  - g. Clothing - low
- Probability of implementing integrated system assuming components can be developed - high
- Variability of development costs for
  - a. Hoses - low
  - b. Filter separators - moderate
  - c. Pump and Drive - low
  - d. Seals - low
  - e. Collapsible drums - low
- Dependence on undeveloped or high cost materials is high to very high

#### 4. Costs

- Annualized cost of capital by component - moderate for most components
- Development costs - high
- Development costs for integrated systems - low
- Operating costs
  - a. Fuel - low to moderate
  - b. Replacement parts - low
  - c. Inventory - low
  - d. Manpower to operate - low
  - e. Extra manpower for maintenance - not known at present time

#### 5. Flexibility and Ease of Use

- Size - small size, high score
- Weight - low weight, high score
- Ease of operation - low down to -40°F, moderate to difficult at temperatures below this
- Set-up time - short, high score
- Dismantling time - short, high score
- Terrain performance and on-site restrictions - high score for both rugged terrain and thick brush or timber
- Operational dependence on special tools, skills - low score because gas turbines require special tools and skills
- Transportability - high score

#### 6. Other Factors

- Safety - moderate
- Security - low
- Vulnerability for 9 situations listed in LOA - high vulnerability and low score for each
- Environmental compatibility - low
- Maintenance time for system as a function of the individual components - moderate, system could require substantial maintenance due to advanced components
- Maintenance frequency for system - moderate

The overall initial evaluation of the system was that it would be flexible, transportable, easy to use, and have good performance specifications. However, in the initial analysis, it appeared that the system would require substantial technological advancement and the results of this would pose reliability issues for operation in the temperature range desired by the Army. Consequently, it appeared that the system would have serious drawbacks in the areas of reliability and development costs. It was also clear, however, that the system would be evaluated in the second stage of scoring.

Having performed only a preliminary evaluation of the system, it was not clear whether the development risk issue would, in the final analysis, be a severe detriment to the rating of the system. Hence, research on fuel supply systems was directed at some of the development risk issues posed by this initial evaluation. In later stages of evaluation the development risk issue was not as serious as originally charged and additional research also showed that the reliability issue was also not a serious issue. However, the evaluation did show (1) which areas future research should be directed and (2) the potential of the baseline system.

### 5.3 STEPS IN EVALUATION PROCEDURE

The overall evaluation procedure evaluated the competing systems in each of the various attributes. The steps in the procedure were as follows:

- Consolidation of system attributes into categories that can be estimated in a first pass evaluation
- Decomposing the rating into several categories. For example, base systems were rated separately from pumps and hosing systems
- Evaluating each alternative and component choice for each attribute, with an absolute score that can be added to scores for other attributes
- Totalling scores for each scenario

Each of these principles is described in the following sections and the resulting analysis is presented in the final section.

### 5.4 CONSOLIDATION OF ATTRIBUTES

The list of attributes presented in Chapter 2 includes all possible system characteristics that we could conceive as relevant to MERADCOM. In the first phase of the evaluation, however, not all of these attributes were absolute requirements of the system and could be eliminated for the purposes of evaluation. In other words, if the system did not receive an adequate rating for the attributes, it could not possibly be considered for further evaluation. As a result, those attributes which were just minimum requirements were omitted from the analysis since each system by design would meet these requirements. Other attributes were judged to be superfluous. For example, transportability was omitted and was judged to be totally a function of size and weight. Other attributes were aggregated with others to simplify scoring.

Those attributes eliminated because they were either superfluous or minimum requirements for the system included:

- Capability of meeting system requirements
- Variability of development cost
- Transportability

In addition the following aggregations were performed to simplify scoring and to reflect the fact that only a certain level of detail could be obtained in the first phase evaluation.

- Probability of system being available and successfully functional (i.e., reliability) at various temperatures was simplified to reliability at -60°F and -20°F as the others were judged to be superfluous.
- Implementation probability using current technology was aggregated in a single rating for all phases
- Probability of developing components was aggregated into a single index.
- Development costs were aggregated for all the components and the integrated system.
- Operating costs for the replacement parts inventory and extra manpower for maintenance was aggregated into other operating costs.
- Operational and maintenance dependence on special tools and skills was aggregated into a single special tools and skills dependence factor.

Thus, the final list of attributes utilized in the *first phase evaluation* consisted of:

Off-loading speed  
Response capability  
-60°F Reliability  
-20°F Reliability  
Lifetime  
Implementation Probability Using Current Technology  
Fuel Flexibility  
Probability of Developing Components  
Probability of Integrating System  
Dependence on High Cost Material  
Capital Cost  
Development Cost  
Fuel Cost  
Manpower Costs  
Other Operating Costs  
Size  
Weight  
Ease of Operation  
Set-up and Dismantling Time  
Rough Terrain Performance  
Dependence on Special Tools and Skills  
Ability to Stand Alone  
Safety

Security  
Vulnerability  
Environmental Compatibility  
Maintenance Time  
Maintenance Frequency

## 5.5 DECOMPOSITION OF ALTERNATIVES

As noted in Chapter 3, there were several concepts proposed for both AFARE and AFSSP. In addition, there were several component variations of these. Starting from the original list of scenarios and considering variations where appropriate,<sup>2</sup> we noted the following range of scenarios:

- 16 Base Scenarios for AFARE
- 21 Base Scenarios for AFSSP
- 4 Pump Possibilities
- 5 Pump Drive Possibilities
- 6 Hosing Alternatives
- 2 Storage Tank Alternatives

The number of combinations of these choices was a very large number. For example, the number of AFSSP scenarios was  $21 \times 4 \times 5 \times 6 \times 2 = 5040$ . As it was infeasible to separately evaluate all of these alternatives, we decided to decompose the evaluation into base scenarios, pumps, pump drives, hosing alternatives and tank alternatives. That is, we rated each pump drive separately, each base scenario separately, and so forth.

This approach is the only feasible one under the circumstances; however, it should be noted that there were implicit assumptions in this approach. The key assumption was that the effects of each variation were additive and independent. That is, for example, it was assumed the effect of a diesel engine was the same for a system without an inflatable shelter as for a system with an inflatable shelter. Although effects are additive in most cases, it was not always the case. For the example cited, a shelter was much more useful for a diesel engine system than for a gas turbine system.

It was judged that the two phase scoring system would overcome this problem. For example, suppose the 21 base scenarios were reduced to 5, the number of pumps reduced to 1, number of pump drives to 2, the number of hosing alternatives to 2 and the number of storage tank alternatives to 2. This would leave a table of 40 complete scenarios (including all combinations). It would be feasible to rate each of these separately. As a result of the decomposition approach, the results in this chapter treat the base system and each of the components separately, where the base systems are assumed to be using (unless otherwise specified) a gas

---

<sup>2</sup> For example, we counted the separate variations of alternative two, but aggregated 2b and 2f. We also aggregated 3a and 3b.

turbine engine, centrifugal pump, and flexible hosing. We also considered variations on some of the original alternatives. For example, the inflatable shelter was posed as a separate alternative for each type of heater.

The candidate AFARE system include:

- Standard or baseline
- Continuous heater
- Portable heater
- Compressed Gas Magneto (gas start)
- Other energy storage
- Compressed air/gas accumulator
- Inflatable shelter with continuous heater
- Inflatable shelter with portable heater
- Rigid shelter with continuous heater
- Rigid shelter with portable heater
- Helicopter tanker
- Recirculate
- Components placed on vehicles
- Microwave energy drive
- Wind energy drive
- Solar (for shelter heat only) energy drive

The candidate AFSSP system include:

- Standard or baseline
- Continuous heater
- Portable heater
- Exhaust heater from vehicles being refueled
- Compressed gas magneto (gas start)
- Other energy storage
- Compressed air/gas accumulator
- Inflatable shelter with continuous heater
- Inflatable shelter with portable heater
- Inflatable shelter exhaust heater from vehicle being refueled
- Rigid shelter with continuous heater
- Rigid shelter with portable heater
- Rigid shelter exhaust heat from vehicles being refueled
- Truck tanker
- Recirculate
- Components placed on vehicles
- Microwave energy drive
- Atomic energy drive
- Wind energy drive
- Solar energy drive
- Take-off shaft from vehicles

Both the AFARE and AFSSP system reflect all possible variations from the first 9 alternatives listed in Chapter 3. (The 10th variation is treated as a storage tank alternative).

The pump alternatives include:

- Scroll
- Peristaltic
- Centrifugal
- Positive Displacement

The pump drive alternatives include:

- Gas Turbine Drive
- Gasoline
- Diesel
- Electrical Motor
- Double Gas Turbine

Note: The double gas turbine drive is an example of a redundant component which we discussed in Chapter 3.

The hosing alternatives include:

- Advanced
- Advanced Small Diameter
- Economic
- Economic Small Diameter
- Rigid
- Rigid Small Diameter

The storage tank alternatives include:

- Collapsible Tanks -60°F
- Rigid Collapsible Tanks

As noted in Chapters 3 and 4, there were some alternatives posed for collapsible tanks and hoses. With regard to collapsible tanks the collapsible feature was viewed as a characteristic that may not be feasible with moderate development and capital expenditures. For hoses, the state-of-the-art materials are also extremely expensive. The economic alternative was envisioned as a future flexible collapsible hosing at a substantially lower cost than the current state-of-the-art. This, as shown in the scoring section, was not rated extremely well. However, as born out by field data research (Chapter 4) and elastomeric research (Chapter 6) some state-of-the-art alternatives such as Goodyear Flexwing are more moderately priced. This type of hosing is not collapsible and was not considered directly in the first phase of scoring. When various state-of-the-art materials were considered in the final evaluation, specific alternatives such as Flexwing were considered.

## 5.6 SCORING METHODOLOGY

For each component alternative and each AFARE and AFSSP alternative, each attribute was rated on a scale of 0 to 5. The results of this scoring are presented in Table 5-1. Note that each score is only a relative score. A 5 on one alternative may have a different implication than a 5 on another alternative. In order to convert these relative scores into an actual comparative score, a transformation was then utilized.

For the relative scores, a 5 generally represented the best among alternatives and in particular consistent with Army goals. A 1 represented a relatively poor rating and a zero represented a serious deficiency. For certain attributes all ratings were fairly high, in which case there were only minor degradations in actual attribute performance. For example, all of the systems were reasonably good performers for manpower costs.

For various attributes the interpretation of the relative scores for the alternatives are as follows:

### Off Loading Speed:

- 4 - Rapid off-loading
- 5 - No set up

### Response Capability

- 1 - Moderate delay in response
- 5 - No delay

(Items that slow response down include working outside, carrying batteries, and heating up components.)

### Reliability at any given temperature

- 1 - 50% or less probability
- 5 - Almost surely works

### Lifetime

- 4 - Less than two years life
- 5 - Two years or more

### Implementation Probability

- 1 - Really not feasible with current technology
- 4 - Current technology acceptable except for tanks
- 5 - Current technology totally acceptable

### Fuel Flexibility

- 1 - One fuel only
- 5 - Flexible

TABLE 5-1  
SCORING FOR  
FSSP ALTERNATIVES

	Off-Loading Speed	Response Capability	-60°F Reliability	-20°F Reliability	Lifetime	Implementation Probability	Using Current Technology	Fuel Flexibility	Probability of Developing Components	Probability of Integrating System	Dependence on High Cost Material	Capital Costs	Development Costs	Fuel Costs	Manpower Costs	Other Operating Costs	Size	Weight	Ease of Operation	Set-up and Dismantling Time	Rough Terrain Performance	Dependence on Special Tools & Skills	Ability to Stand Alone	Safety	Security	Vulnerability	Environmental Compatibility	Maintenance Time	Maintenance Frequency	
1. Standard	4	1	2	5	5	4	4	5	5	5	4	5	4	5	5	5	5	5	5	4	5	5	5	5	5	2	3	5	5	
2. Continuous Heater	4	3	3	5	5	3	3	5	5	2	4	4.5	2.5	2.5	5	4	5	4.75	4	4	4	5	4	5	5	2	3	5	5	
3. Portable Heater	4	1	2	5	5	4	4	5	4	4	4	4.75	4	5	5	5	5	5	5	4	4	5	4	5	3	2	3	5	5	
4. Exhaust Heater	4	1.5	2.5	5	5	3	3	5	5	2	4	4.5	2.5	5	5	4.5	5	4.75	3	4	5	4	5	4.5	2	3	5	5	5	
5. Compressed Magneto	4	3	3	5	5	4	4	5	4	4	4	4.75	3	5	5	3.5	4.75	4.75	5	3.5	5	4.5	5	4.5	2	3	5	5	5	
6. Other Energy Storage	4	3	3	5	5	1	4	2	1	4	4	4	2	5	5	3	4	4.25	5	3.5	5	4.5	5	5	2	3	5	5	5	
7. Compressed Air/Gas Accumulator	4	3	3	4	4	1	4	2	1	2	2	4	2	4	5	3	4.75	4.5	3	3.5	5	3	5	2	2	3	5	5	5	
8. Shelter-Continuous	4	4	4	5	5	4	4	5	5	5	5	4.5	3.5	4	5	4	4.5	4.5	5	3.5	4	3.5	5	4.5	1	3	5	5	5	
9. Shelter-Portable	4	3	4	5	5	4	4	5	5	5	5	4.5	3.5	5	5	5	4.5	4.75	5	3.5	4	3.5	5	3	1	3	5	5	5	
10. Shelter-Exhaust	4	3	4	5	5	4	4	5	5	5	5	4.5	3.5	5	5	4.5	4.5	4.5	3	3.5	4	3.5	5	4.5	1	3	5	5	5	
11. Rigid-Continuous	4	4	4	5	5	4	4	5	5	5	5	4.5	3.5	4	5	4	3	4.0	5	3	4	3.5	5	4.5	1	3	5	5	5	
12. Rigid-Portable	4	3	4	5	5	4	4	5	5	5	5	4.5	3.5	5	5	5	3	4.25	5	3	4	3.5	5	3	1	3	5	5	5	
13. Rigid-Exhaust	4	3	4	5	5	4	4	5	5	5	5	4.5	3.5	5	5	4.5	3	4.0	3	3	4	3.5	5	4.5	1	3	5	5	5	
14. Tanker	5	5	5	5	5	5	5	5	5	5	5	4	5	2	4	2	3	1	5	5	3	5	5	1	No Difference	1	3	5	5	5
15. Recirculate	4	5	5	5	5	4	4	5	5	5	5	5	4	2	5	2	5	5	5	4	5	5	3	5	2	3	5	1	1	1
16. Place on Vehicles	5	5	5	5	5	4	4	5	5	5	5	2	3	5	5	4	5	5	5	4.5	5	5	5	5	3	3	5	5	5	5
17. Microwave	4	3	2	2	5	0	0	0	0	1	2	2	1	5	5	2	3	3.5	3	1	5	1	5	5	5	1	3	2	5	5
18. Atomic	4	3	5	5	5	4	4	3	4	4	4	1	3	5	3	2	2	0	3	0	3	1	1	1	1	1	2	1	5	5
19. Wind	4	3	4	5	5	3	3	3	4	4	4	4	2	5	5	3.5	3.5	3.5	5	1	3	3	5	5	1	3	3	5	5	5
20. Solar	4	3	1	5	5	3	3	2	3	2	3	3	2	5	5	4	3	3.5	5	1	3	3	5	5	1	3	3	5	5	5
21. Take-off Shaft	4	4	5	5	5	4	4	5	5	5	5	2	3.5	5	5	4.5	5	5	5	4	5	5	5	5	2	3	5	5	5	5

TABLE 5-1  
SCORING FOR  
FARE ALTERNATIVES

	Off-Loading Speed	Response Capability	-60°F Reliability	-20°F Reliability	Lifetime	Implementation Probability	Using Current Technology	Fuel Flexibility	Probability of Developing Components	Probability of Integrating System	Dependence on High Cost Material	Capital Costs	Development Costs	Fuel Costs	Manpower Costs	Other Operating Costs	Size	Weight	Ease of Operation	Set-up and Dismantling Time	Rough Terrain Performance	Dependence on Special Tools & Skills	Ability to Stand Alone	Safety	Security	Vulnerability	Environmental Compatibility	Maintenance Time	Maintenance Frequency
1. Standard	4	1	2	5	5	4	4		5	5	4	5	4	5	5	5	5	4	5	4	5	5	5	5	2	3	3	5	5
2. Continuous Heater	4	3	3	5	5	3	3		5	2	4	4.5	2.5	2.5	5	4	5	3.5	5	4	5	4	5	5	2	3	3	5	5
3. Portable Heater	4	1	2	5	5	4	4		5	4	4	4.75	4	5	5	5	5	4	5	4	5	4	5	3	2	3	3	5	5
4. Compressed Gas Magneto	4	3	3	5	5	4	4		5	4	4	4.75	3	5	5	3.5	4.5	3.5	5	3.5	5	4.5	5	4.5	2	3	3	5	5
5. Other Energy Storage	4	3	3	5	5	1	1		2	4	4	4	2	5	5	3	3	2.5	5	3.5	5	4.5	5	5	2	3	3	5	5
6. Compressed Air/Gas Accumulator	4	3	3	4	4	1	1		2	1	2	4	2	5	5	3	4.5	3	3	3.5	5	3	5	2	2	3	3	5	5
7. Shelter-Continuous	4	4	4	5	5	4	4	No Difference	5	5	5	4.5	3.5	4	5	4	4	3	5	3.5	4	3.5	5	4.5	1	3	3	5	5
8. Shelter-Portable	4	3	4	5	5	4	4		5	5	5	4.5	3.5	5	5	5	4	3.5	5	3.5	4	3.5	5	3	1	3	3	5	5
9. Rigid-Continuous	4	4	4	5	5	4	4		5	5	5	4.5	3.5	4	5	4	1	2	5	3	4	3.5	5	4.5	1	3	3	5	5
10. Rigid-Portable	4	3	4	5	5	4	4		5	5	5	4.5	3.5	5	5	5	1	2.5	5	3	4	3.5	5	3	1	3	3	5	5
11. Helicopter	5	5	5	5	5	5	5		5	5	5	1	5	1	3	1	5	5	3	5	3	1	1	1	1	1	3	1	2
12. Recirculate	4	5	5	5	5	4	4		5	5	5	5	4	2	5	2	5	4	5	4	5	5	3	5	1	3	3	5	1
13. Place on Vehicles	5	5	5	5	5	4	4		5	5	5	2	3	5	5	4	5	5	5	4.5	5	5	5	5	3	3	3	5	5
14. Microwave	4	3	2	2	5	0	0		0	0	1	2	1	5	5	2	1	1	3	1	5	1	5	5	1	1	3	2	5
15. Wind	4	3	4	5	5	3	3		5	3	5	4	2	5	5	3.5	2	1	5	1	3	3	5	5	1	1	3	3	5
16. Solar (For shelter heat only)	4	3	1	5	5	3	3		3	2	3	3	2	5	5	4	1	1	5	1	3	3	5	5	1	1	3	3	5

TABLE 5-1

SCORING FOR  
PUMP ALTERNATIVES

	Off-Loading Speed	Response Capability	-60°F Reliability	-20°F Reliability	Lifetime	Implementation Probability	Using Current Technology	Fuel Flexibility	Probability of Dev. Components	Probability of Integrating System	Dependence on High Cost Material	Capital Costs	Development Costs	Fuel Costs	Manpower Costs	Other Operating Costs	Size	Weight	Ease of Operation	Set-up and Dismantling Time	Rough Terrain Performance	Dependence on Special Tools and Skills	Ability to Stand Alone	Safety	Security	Vulnerability	Environmental Compatibility	Maintenance Time	Maintenance Frequency
1. Scroll Pumps	No Difference	3	5	5	5	2	No Difference	3	No Difference	No Difference	5	4	1	No Difference	No Difference	No Difference	1	3	No Difference	No Difference	No Difference	No Difference	No Difference	No Difference	No Difference	No Difference	No Difference	No Difference	4
2. Peristaltic Pumps	No Difference	1	1	1	3	1	No Difference	1	1	No Difference	5	4	1	No Difference	No Difference	No Difference	1	3	No Difference	No Difference	No Difference	No Difference	No Difference	No Difference	No Difference	No Difference	No Difference	No Difference	2
3. Centrifugal Pumps	No Difference	5	5	5	5	5	No Difference	5	5	No Difference	5	5	5	No Difference	No Difference	No Difference	5	5	No Difference	No Difference	No Difference	No Difference	No Difference	No Difference	No Difference	No Difference	No Difference	No Difference	5
4. Positive Displacement	No Difference	5	5	5	4.5	5	No Difference	5	5	No Difference	5	4	5	No Difference	No Difference	No Difference	4	4	No Difference	No Difference	No Difference	No Difference	No Difference	No Difference	No Difference	No Difference	No Difference	No Difference	4

TABLE 5-1

SCORING FOR  
PUMP DRIVE ALTERNATIVES

	Off-Loading Speed	Response Capability	-60°F Reliability	-20°F Reliability	Lifetime	Implementation Probability	Using Current Technology	Fuel Flexibility	Probability of Dev. Components	Probability of Integrating System	Dependence on High Cost Material	Capital Costs	Development Costs	Fuel Costs	Manpower Costs	Other Operating Costs	Size	Weight	Ease of Operation	Set-up and Dismantling Time	Rough Terrain Performance	Dependence on Special Tools and Skills	Ability to Stand Alone	Safety	Security	Vulnerability	Environmental Compatibility	Maintenance Time	Maintenance Frequency
1. Gas Turbine Drive	No Difference	5	5	5	4.5	5	5	5	5	No Difference	3	2	4	No Difference	No Difference	4	5	5	4	No Difference	No Difference	No Difference	No Difference	4	No Difference	No Difference	No Difference	3	5
2. Gasoline Drive	4	4	3	4	4	5	2	5	5	5	5	5	5	5	5	3	4	3	3	No Difference	No Difference	No Difference	4	5	No Difference	No Difference	4	4	4
3. Diesel Drive	3	3	4	4.5	5	5	2	5	5	No Difference	5	3	5	No Difference	No Difference	5	4	2	2	No Difference	No Difference	No Difference	5	5	No Difference	No Difference	4	5	5
4. Electric Motor Drive	3	3	3	4	4.5	5	3	5	5	5	5	3	5	No Difference	No Difference	3	3	3	4	No Difference	No Difference	No Difference	5	5	No Difference	No Difference	4	4	4
5. Double Gas Turbine Drive	5	5	5	5	4.5	5	5	5	5	No Difference	3	1	4	No Difference	No Difference	4	5	5	4	No Difference	No Difference	No Difference	4	5	No Difference	No Difference	3	5	5



TABLE 5-1

SCORING FOR  
TANK ALTERNATIVES

	1. Collapsible Tanks -60°F	2. Rigid Collapsible Tanks
Off-Loading Speed	5	5
Response Capability	No Difference	3
-60°F Reliability	No Difference	3
-20°F Reliability	No Difference	No Difference
Lifetime	4.5	5
Implementation Probability	2	5
Using Current Technology	No Difference	No Difference
Fuel Flexibility	3	5
Probability of Dev. Components	No Difference	No Difference
Probability of Integrating System	No Difference	No Difference
Dependence on High Cost Material	4	5
Capital Costs	5	4
Development Costs	2	5
Fuel Costs	No Difference	No Difference
Manpower Costs	No Difference	No Difference
Other Operating Costs	No Difference	No Difference
Size	5	2
Weight	4	4
Ease of Operation	No Difference	No Difference
Set-up and Dismantling Time	5	4
Rough Terrain Performance	5	4
Dependence on Special Tools and Skills	No Difference	No Difference
Ability to Stand Alone	No Difference	No Difference
Safety	No Difference	No Difference
Security	No Difference	No Difference
Vulnerability	No Difference	No Difference
Environmental Compatibility	No Difference	No Difference
Maintenance Time	No Difference	No Difference
Maintenance Frequency	No Difference	No Difference

Probability of Developing Components

- 0 - Extremely unlikely
- 2 - Not likely
- 5 - Very probable

Probability of integrating system

- 1 - Severe interface problems
- 5 - Integration no problem

Dependence on High Cost Materials

- 1 - Great dependence on exotic or high cost materials
- 4 - Hoses and collapsible tanks are only issues
- 5 - Very little dependence on high cost materials

Capital Costs (See Text)

- 1 - \$100,000,000 for AFARE or approximately two orders of magnitude larger than baseline for AFSSP.
- 5 - \$2,000,000 for AFARE, no more than baseline for AFSSP

Development Costs

- 1 - Significant Development
- 5 - None or little

Fuel Costs

- 2 - Three gallons per hour for AFARE, 9 for AFSSP
- 5 - Nothing in excess of the fuel being transferred

Manpower Costs

- 3 - Needs dedicated manpower
- 5 - Can be unattended

Other Operating Costs

- 1 - A high degree of operating cost
- 3 - Frequent inspection and moderate parts with 3 to 4 overhauls per year

Size

- 1 - Rigid with some size problems
- 5 - No bigger than standard baseline system

Weight

For AFARE

- 1 - 1,200 pounds or more
- 3 - Approximately 1,000 lbs.
- 4 - Standard, about 900 pounds
- 5 - Nothing

For AFSSP

- 1 - Significantly heavier than baseline
- 4 - Slightly heavier than baseline on a percentage basis
- 5 - About the same as the baseline, or well within guidelines

Ease of Operation

- 3 - Some difficulty
- 5 - Easy

Set-up and Dismantling Time

- 1 - Difficult
- 5 - None

Rough Terrain Performance

- 3 - Some difficulty
- 5 - No degradation

Dependence on Special Tools and Skills

- 1 - Specialized expertise required
- 5 - None required

Ability to Stand Alone

- 1 - Must be manned
- 3 - Attendance Preferred
- 5 - Can be left alone

Safety

- 1 - Some safety problems
- 5 - No unusual problems

Security, Vulnerability

- 1 - Very vulnerable
- 3 - System somewhat vulnerable

AD-A071 815

LITTLE (ARTHUR D) INC CAMBRIDGE MASS  
SYSTEMS ANALYSIS OF ARCTIC FUELS DISPENSING EQUIPMENT.(U)  
JUN 79 D B ROSENFELD, E A GILBERT

F/G 21/4

UNCLASSIFIED

ADL-80260-18

DAAK70-77-D-0024

NL

2 OF 2  
AD  
A071815

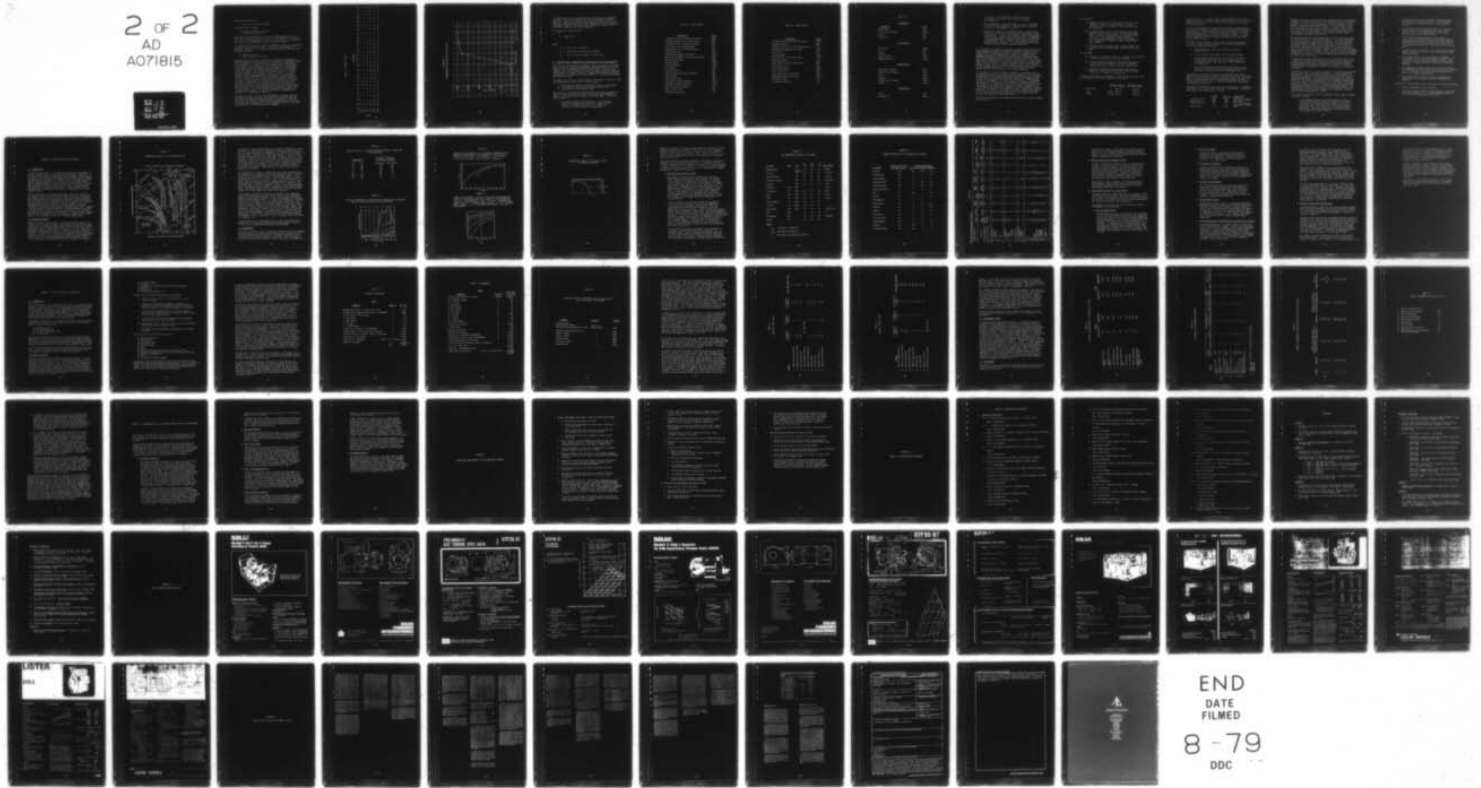

END  
DATE  
FILMED  
8-79  
DDC

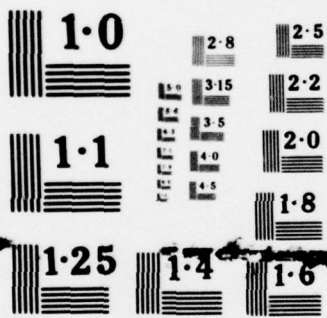

NATIONAL BUREAU OF STANDARDS  
MICROCOPY RESOLUTION TEST CHART

### Environmental Compatibility

- 3 - Can inflict environmental damage

### Maintenance Time, Frequency

- 1 - Frequent or lengthy maintenance
- 5 - No unusual requirements

Note that for some categories, the scales for AFARE and AFSSP are not the same. For example, weight is more critical for AFARE and is modified more significantly by component variations. Rating scales for components were rated on an analogous basis as the alternative systems.

The conversion of the relative scores into absolute scores was accomplished by means of a transformation table. The table of transformations is presented in Table 5-2. In developing the transformations there were two principles employed.

1. Non-linear utility
2. Unequal weights of attributes

The non-linearity of utility is necessary to differentiate between acceptable and unacceptable alternatives. For example, in developing capital costs for AFARE, a 1 represented a cost of about 100 million dollars, a 3 represented a cost of about 10 million dollars, and a 5 represented a cost of about 2 million dollars. This was based on a rough estimate of 100 AFARE systems and 5,000 vehicles being refueled. A helicopter system, for example, would require 100 helicopters at a cost of about a million dollars a piece which would result in score of 1. A more inexpensive system would represent a score of 3 to 5. A helicopter system is clearly unacceptable and we transformed a relative score of 1 to an absolute score of 0. On the other hand, we rated a score of 3 at 470, a score of 4 at 495, and a score of 5 at 500. With this type of scoring transformation, we reflected the fact that there is not a great deal of emphasis on capital cost within a specific range (for example, there is very little difference between a 3 and a 5) but there is a huge penalty for a large capital cost (1 results in a score of 0). The other sources in the scoring table reflected the non-linear transformation where necessary. A graph depicting the transformation of capital costs is presented in Figure 5-2.

The other principle in the scoring transformation was unequal weights. Attributes that were relatively important showed a spread of 100, attributes that were moderately important showed a spread of 50 to 80, and attributes that were not important showed a scoring spread of 25 or less. The scoring table indicates the relative importance of various attributes as ascertained in our conversations with MERADCOM.

TABLE 5-2 SCORING TABLE

ATTRIBUTE

	1	2	3	4	5	6	7	8	9	10	11	12	13	14	15	16	17	18	19	20	21	22	23	24	25	26	27	28	
0	0	0	0	0	0	0	0	0	0	0	0	0	0	0	0	0	0	0	0	0	0	0	0	0	0	0	0	0	0
1	0	0	0	0	0	0	0	10	10	0	0	0	0	0	0	0	0	0	0	0	0	0	0	0	0	0	0	0	0
2	0	40	0	0	0	5	10	20	20	5	10	440	10	15	15	20	0	10	5	3	3	5	20	0	5	0	10	20	
3	0	60	10	0	5	15	20	30	30	10	470	470	20	40	40	40	40	30	10	6	6	70	40	0	10	0	20	35	
4	10	60	50	80	10	40	30	40	40	20	490	480	30	60	60	60	80	50	20	9	9	90	55	0	15	0	30	50	
5	20	100	60	100	15	50	40	50	50	25	500	500	40	80	80	70	90	65	25	12	12	100	70	0	20	0	35	65	

SCORE

FIGURE 5-2  
TRANSFORMATION FUNCTION FOR CAPITAL COSTS

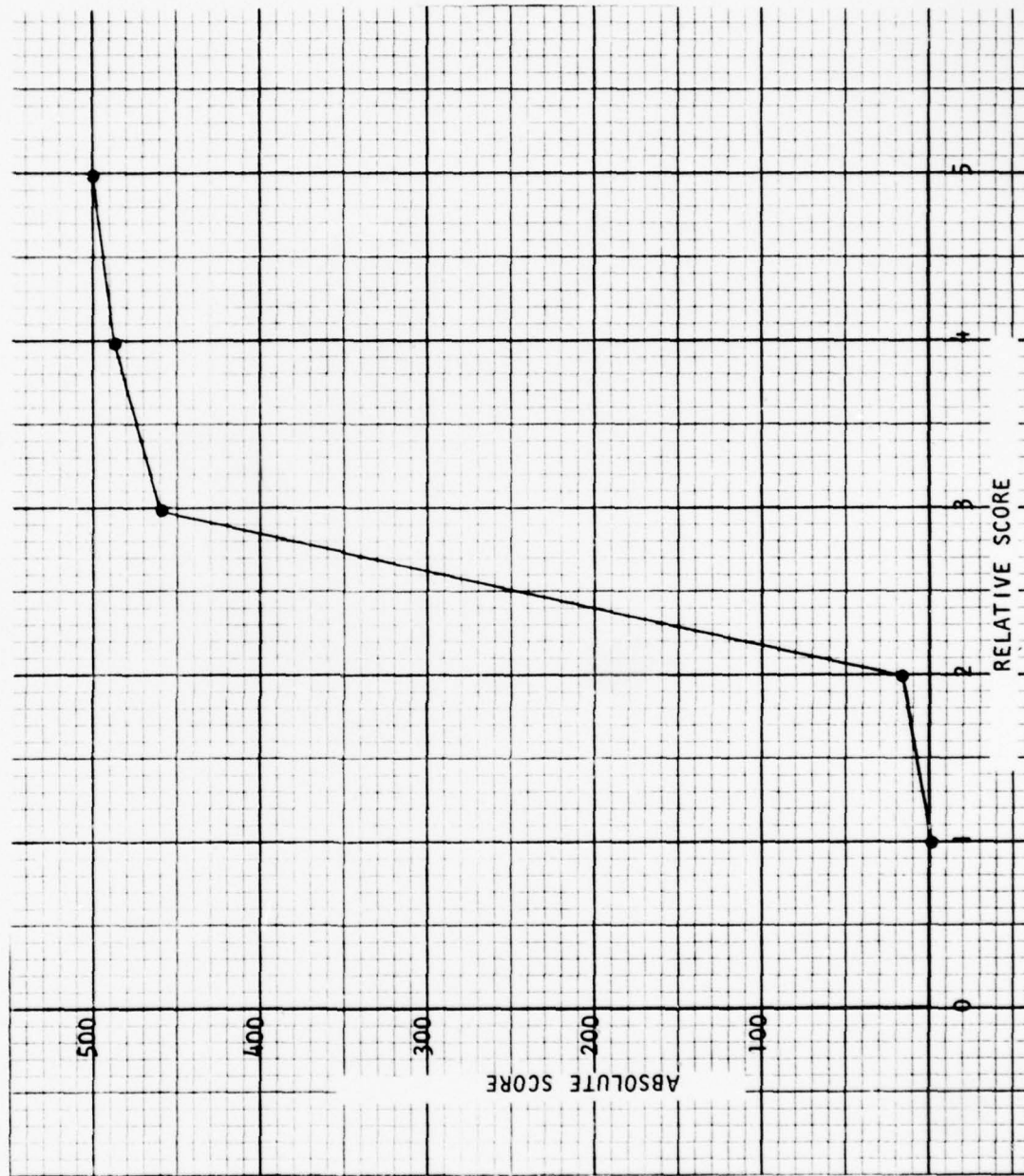

In establishing the transformation values, conversations with MERADCOM staff were initiated to establish the relative importance of certain qualities. Levels of an attribute were rated as either essential, very important, moderately important, of minor importance, or of no importance. For example, high -60°F reliability was rated as very important while high -40°F reliability was rated as essential.

The equation for total score was

$$S_j = \sum_i F_i(x_{ij})$$

where

$S_j$  = total score for concept j

$F_i$  = transformation function for attribute i

$x_{ij}$  = relative score of concept i for attribute j

#### 5.7 SCORING TOTALS, INTERPRETATION, AND CANDIDATES FOR FINAL EVALUATION

This final section presents the tabulated scores, analyzes and interprets these scores, and presents the candidates subsequently chosen for further analysis. The interpretation was not simply a matter of choosing the highest scores in each category, but also included an analysis of feasible combinations. For example, could the highest scoring hosing alternative be used with the highest scoring pump alternative? The analysis addressed this and other issues.

The total scores for each scoring category are presented in Table 5-3 - 5-5. The subsequent analysis was split into three steps:

1. Refinement and reevaluation using the initial scoring systems.
2. A more detailed analysis of the pump and hosing issue.
3. An appraisal of the evaluated scores.

The first step, refinement and reevaluation was performed to account for additional considerations that arose in discussions with MERADCOM personnel. The original scores are omitted from this report. The refinements included:

1. On comparing systems utilizing heaters it was noted that there would be some severe feasibility problems without shelters. We therefore adjusted scores relating to reliability of those systems utilizing heaters

TABLE 5-3 - AFSSP SCORING

<u>Alternative</u>	<u>Score</u>
Inflatable Shelter with Continuous Heater	2059
Inflatable Shelter with Portable Heater	2049
Inflatable Shelter with Exhaust Heater	2034
Rigid Shelter with Portable Heater	2024
Rigid Shelter with Continuous Heater	2014
Standard Baseline	2009
Compressed Gas Magneto (Gas Start)	2007.5
Rigid Shelter Exhaust from Vehicle Refueled	1999
Recirculating System	1984
Portable Heater	1963.5
Continuous Heater	1928.5
Truck Tanker	1893
Wind Energy Drive	1892
Exhaust Heater from Vehicle Refueled	1891
Other Storage	1855
Solar Energy Drive	1782
Compressed air/gas Accumulator	1735.5
Components Placed on Vehicles	1671.5
Take-off shaft from Vehicle	1629
Atomic Energy Drive	1061
Microwave Energy Drive	617

TABLE 5-4 - AFARE SCORING

<u>Alternative</u>	<u>Score</u>
Inflatable Shelter with Portable Heater	2026.5
Standard Baseline	1999
Inflatable Shelter with Continuous Heater	1999
Compressed gas/magneto (Gas Start)	1997.5
Recirculate	1969
Portable Heater	1938.5
Rigid Shelter with Portable Heater	1921.5
Continuous Heater	1916
Rigid Shelter with Continuous Heater	1894
Wind Energy Drive	1807
Other Energy Source	1802.5
Solar Energy Drive	1688
Compressed air/gas Accumulator	1682
Components Placed on Vehicles	1671.5
Helicopter Tanker	1251
Microwave Energy Drive	517

TABLE 5-5

Pump Scoring

<u>Alternative</u>	<u>Score</u>
Centrifugal	1625
Positive Displacement	1577.5
Scroll	875
Peristaltic	590

Drive Scoring

Gas Turbine	1782.5
Diesel	1635
Gasoline	1615
Electric Motor	1597.5
Double Gas Turbine	1312.5

Hosing Scoring

Rigid Small Diameter	1318
Advanced Small Diameter	1314.5
Rigid	1288
Advanced	1259.5
Economic Small Diameter	1194.5
Economic	1144.5

Tank Scoring

Rigid	1334
Collapsible	1224.5

As a result of this adjustment, systems with heaters and shelters score better than systems with heaters and no shelters.

2. Due to MERADCOM's concern with operating costs, we upgraded the scale of these categories. (This particular change did not result in any changes in ratings.)
3. Some of the highest scoring systems included systems placing components on vehicles or deriving power from take-off shafts on the vehicle. In the initial analysis, these systems scored extremely well. However, after some discussion with MERADCOM, it was concluded that the capital cost for such a system would be prohibitively high. In order to implement such a system every helicopter and vehicle in military inventory would need retrofitting, an extremely expensive proposition.

It is worthwhile to present some discussion concerning some systems that were outstanding performers but extremely expensive. These systems included tankers, dedicated helicopters, systems with components on the refueled vehicles, and systems deriving power from take-off shafts. MERADCOM has desired in the course of this study to recognize systems that were outstanding performers despite the level of the cost. All of these systems named would fall into this classification. If the capital costs were not considered in the scoring, these systems would have placed highest in total scores. There were, however, order of magnitude differences between the cost of these systems and systems that were variants of the standard baseline system. It is worth noting in the report, however, how well these systems scored in other categories.

In formulating the final candidates for analysis, a separate analysis was necessary to examine the issue of pumps and hosing. The first phase evaluation analyzed systems and components as separate scoring problems. In other words, it was assumed that the interaction of component based systems was independent. Since this was not the case, it was necessary to look at the combinations of the components and systems to determine the feasibility. To some extent this analysis could be performed in the final phase of the evaluation but some issues had to be resolved prior to the formulation of the final candidates. The most important of these issues was the compatibility of hoses and pumps. In particular, because hosing systems utilizing small diameters and high pressure scored very well, it was necessary to examine the issue of which combination pump and hosing type would be the most desirable.

The following observations were made concerning the use of smaller diameter pipes and hosing.

For the AFSSP:

- (a) A reduction in pipe size from 6" to 4" would raise the pressure from 100 psi to around 600 psi. Further reduction of pipe size except for small sections would be impractical.
- (b) The higher pressure of this range of power level would probably require a piston type or positive displacement pump. This would weigh somewhere in the range of 1500 lbs. or more. For comparison the centrifugal pump required to produce 600 GPM at 100 psi weighs about 230 lbs. A gear pump also capable of 100 psi would weigh about 800 lbs.
- (c) The cost of the centrifugal pump is \$1200 to \$1500. The comparative positive displacement pumps would cost much more.

For the AFARE:

- (a) A reduction in pipe size from 2" to 1" results in an increase in pressure from 150 psi to several thousand.
- (b) If such a change were feasible, the system would require a piston pump with a weight of 1150 lbs. for 200 GPM compared with the centrifugal pump which weighs 230 lbs.
- (c) A positive displacement pump would again be extremely expensive. For the envisioned system, therefore, hoses less than 2" in diameter are impractical.

If pipe and hosing were not decreased in size, and system pressure were not increased, the following comparisons would apply:

	<u>600 GPM @ 100 psi</u>	<u>200 GPM @ 150 psi</u>
Centrifugal	230 lbs.	230 lbs.
Gear	Approx. 800 lbs.	190 lbs.
Piston	Approx. 1500 lbs.	600 lbs.

Since the positive displacement pumps are more expensive, more subject to wear and failure, and larger, then, as borne out by the scoring, centrifugal pumps would be superior and would be the choice for all systems in the final evaluation.

In view of the limitations of small diameter hosing it became apparent that hosing would become an extremely critical issue in the final costing and evaluation. As noted previously, additional research into elastomers became necessary. In the final evaluation, of course, various types of advanced state-of-the-art hosing were considered. (It should also be noted that the design diameter for AFARE hosing, two inches, is not extremely large.)

The final step in the Phase I analysis was a subjective evaluation of the scores. These evaluations included the following observations, some of which have been noted above.

1. Aside from capital costs, gas turbines were clearly a superior drive.
2. Centrifugal pumps were judged to be the most desirable.
3. As noted above, high pressure hosing was ruled out because of the pump implications. This left various types of advanced hosing and rigid pipes with flexible connections as alternatives.
4. Both collapsible and non-collapsible tanks remain possible choices. Although collapsible tanks would be highly preferable, there is clearly an issue of development risk.

With regard to the fourth conclusion, the collapsible tanks remain another serious development problem for the baseline systems. Collapsible tanks may not be a feasible goal for the design systems. Together with hosing, the development issue for collapsible tank points out the remaining problems in elastomers. Additional research on this subject is presented in Chapter 6.

Because of the dominance of gas turbine over diesel engines, we examined cost issues prior to posing the final Phase II alternative. A cost and weight comparison was performed as follows:

	<u>Cost (\$)</u>	<u>Size, In<sup>3</sup></u>	<u>Weight (lbs.)</u>
20 HP Gas Turbine	24K	9K	89 (Without gearbox)
20 HP Diesel	2K-3K	18K	300 - 400
50 HP Gas Turbine	25K	20K	370 (With gearbox)
			200 (Without gearbox)
50 HP Diesel	5K	40K	1000

The engine issue was also affected by the independent issue from analyzing components and systems separately. Even though gas turbines were superior to diesels in several scoring categories, we had not answered in Phase I whether a diesel engine would be sufficient to meet the design criteria within the baseline systems posed in Phase I. In other words, we were not sure whether the gas turbine would be any superior to diesel within the systems posed as alternatives. Since the diesel engine was so much more economical, we were obligated to incorporate the diesel engine within some of the Phase II alternatives.

With regard to particular base alternatives, we simply chose the highest scoring alternatives for both AFARE and AFSSP. In restricting ourselves to one type of shelter, we noted that there was very little difference in scoring between inflatable and rigid shelters. Our conclusion was that the best shelter concept would be some type of shelter that could be readily dismantled and constructed, weigh very little, and occupy very little space when transported. However, we would consider a shelter large enough to house an individual, as this is in line with the inflatable shelter concept. We cut off heaters without shelters as they are dominated by heaters with shelters. As a result of these considerations we arrived at a final set of alternatives.

In examining the final alternatives the other outstanding research issue in addition to elastomerics was batteries. Several of the final alternatives would need some type of advanced battery and the availability of these batteries were extremely important in the Phase II analysis. The discussion of the research involved in this issue is also presented in Chapter 6.

As the Phase I analysis was being completed it was noted that the standard baseline system had a high degree of potential. It was flexible and transportable. The gas turbine engine was an excellent performer, and, aside from elastomerics, the only real issue was in starting. Use of either advanced battery or a compressed gas and magneto system would be sufficient. The overall design might not be as reliable as others such as the continuously recirculating system. For this reason, we posed an additional alternative which was the standard baseline system with both a compressed gas/magneto starting system and an advanced battery. The compressed gas would drive an air motor to start the gas turbine engine. The redundancy in starting might increase the reliability to a point where such a system dominated all others.

Thus, the final alternatives (for both AFARE and AFSSP) chosen for Phase II analysis included:

1. A system with some type of collapsible shelter utilizing a small portable heater whenever the system is to be placed in operation. The system utilizes a diesel drive and a centrifugal pump. (All alternatives would utilize a centrifugal pump.) The system would utilize an advanced battery and therefore there was no advantage to using a gas turbine engine rather than a diesel engine.

2. A system with some type of collapsible shelter and either an intermittent or continuous heater. This system would utilize a diesel engine and would not require advanced batteries.
3. A continuously recirculating system with a diesel engine. Because of the high fuel consumption by a gas turbine engine at idle, it was judged that this system would more appropriately use a diesel engine.
4. (This alternative was appropriate only for AFSSP.) A system with some type of collapsible shelter and a heating system based on the exhaust of the vehicles being refueled. This system would require an advanced battery and would thus be appropriate (as System 1 would be) only for a diesel engine.
5. A system similar to System No. 2 but utilizing a gas turbine engine. Because of the shelter, the system would not need advanced batteries.
6. The standard baseline system as suggested by MERADCOM. This system would require some type of advanced battery. The system would utilize a gas turbine engine. A diesel engine would not be appropriate because of cold weather starting problems.
7. The compressed gas/magneto system with a gas turbine engine. The compressed gas start would replace the batteries in System No. 6. An example of a suitable compressed gas would be bottled dry nitrogen compressed gas.
8. The standard baseline system with both a compressed gas/magneto system and an advanced battery for redundancy in starting.

In addition to the above base system, we posed the following variations:

1. Either collapsible or rigid tanks, and
2. Some type of state-of-the-art flexible hosing or rigid tubes with flexible connections. Very small diameters would be used only at the nozzle ends of the system.

## CHAPTER 6 - FINAL STATE-OF-THE-ART RESEARCH

### 6.1 INTRODUCTION

In evaluating the final list of technical alternatives, development risk plays an important role. In the first phase evaluation, some of the concepts requiring advanced development were eliminated. These included, for example, the accumulating compressor and the atomic and wind-powered advanced energy storage devices. However, many of the remaining systems require advanced development. As an example, the sheltered systems require some development on shelter design. Existing shelters included both inflatable shelters as well as rigid shelters. A second area is the development of compressed gas starters. The technology has been developed, but some additional development is required for arctic fuel resupply systems.

Of the various areas for possible development, there are two areas of particular interest. For both of these areas, the current state-of-the-art indicates that appropriate products can be developed for the AFARE and AFSSP systems but, in both cases the technology is new and expensive. The two areas are those of advanced batteries (our name given to recently developed batteries which essentially function normally at very low temperatures) capable of starting gas turbine engines at  $-60^{\circ}\text{F}$  and elastomerics for both flexible hosing and collapsible fuel tanks. Because of the importance of these technologies in the performance of the AFARE and AFSSP systems, sections on the state-of-the-art for the two areas are presented in the remainder of this chapter. These two areas, advanced batteries and elastomerics remain as the critical areas of future development in the procurement of the final AFARE and AFSSP systems.

### 6.2 ADVANCED BATTERIES

The most important characteristic of a battery for engine starting is a capability for high rate discharge. This capability for different types of batteries is conveniently demonstrated in the attached plot of specific power versus specific energy shown in Figure 6-1. For very high rate discharge, using a 0.1 hour rate as a guideline, only four systems qualify--lead-acid, nickel-cadmium, nickel-zinc, and lithium-inorganic (thionyl chloride). Of these the first three are rechargeable, the lithium battery is a primary system. Also the nickel-zinc system, though available for several years, is not an established technology and probably should not be considered in an application where high reliability is important.

FIGURE 6-1

PERFORMANCE CAPABILITIES OF VARIOUS BATTERIES

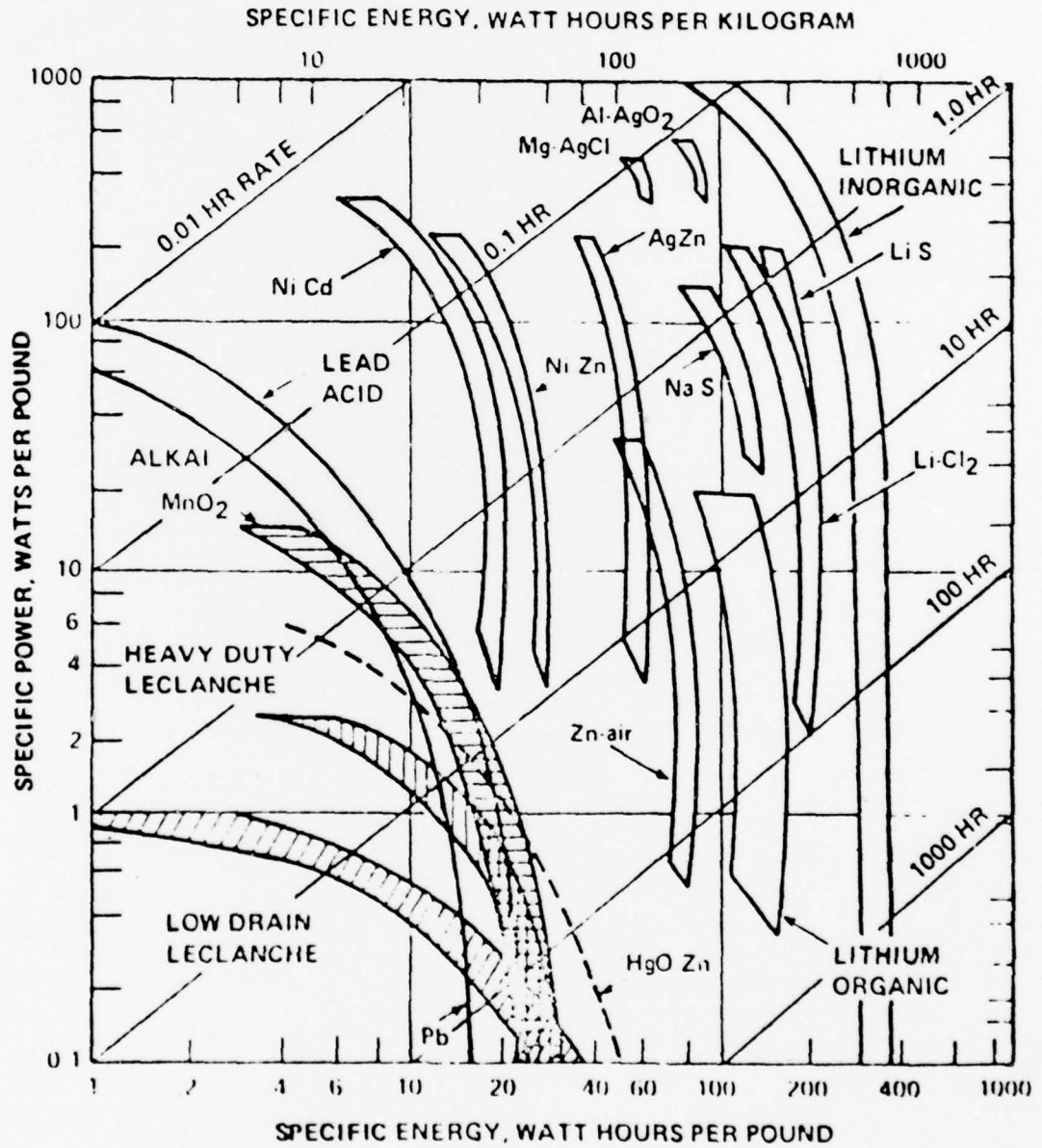

The behavior of lead-acid batteries as a function of temperature is given in Figure 6-2. More specific information on the power capabilities at very low temperatures would be dependent on cell design and configuration. One point that is apparent from Figure 6-2, however, is that the lead-acid battery would not meet the requirements of engine starting at  $-40^{\circ}\text{F}$  or below. The reason for this is the rapid increase in viscosity of the electrolyte, (See Figure 6-3) which impairs its circulation in the pore structure of the plates. This results in local freezing due to dilution of the electrolyte on discharge. On this basis a lead-acid battery is not suitable for this application unless some form of heating were incorporated in the design. (Note that there is capacity available at  $-60^{\circ}\text{F}$  at a low rate.)

The nickel-cadmium battery is recognized as one of the best systems for low temperature use, though very high rate operation at  $-60^{\circ}\text{F}$  is reaching to the limit of the capability of the system and does require a more concentrated electrolyte than normal. The available capacity at normal discharge and at the 0.1 hour rate are shown in Figures 6-4 and 6-5. At the 0.1 hour rate the power density is approximately  $20 \text{ m W/cm}^2$ . Some "bootstrapping" is possible in nickel-cadmium cells in which high rate discharge raises the internal temperature which in turn improves performance. The magnitude of this effect is dependent on cell design and duty cycle. The thermal conductivity and thermal mass of the cell are more favorable for nickel-cadmium than they are for lead-acid.

Lithium-thionyl chloride primary cells are chosen for low temperature duties mainly because they can deliver 40% of their normal temperature capacity at  $-60^{\circ}\text{F}$  (See Figure 6-6). Their peak power density, however, falls from  $250 \text{ m W/cm}^2$  at  $-60^{\circ}\text{F}$ . This means some  $20,000 \text{ cm}^2$  of electrode surface to deliver 100A which is not beyond current technology in fairly large cells. For example, Altus Corporation makes 500 Ahr cells that can be discharged at 100A, and if 100 Ahr capacity is required at  $-60^{\circ}\text{F}$  then cells as large as 500 Ahr nominal might be required. However, this performance is not really superior to that of the nickel-cadmium system which offers the advantages of a secondary battery. Costs for the two systems are also comparable. Batteries are constructed with inter-cell heating pads. Each is a custom design and their effectiveness depends on frequency of use of the battery, time for recharge, duty cycle, extent of insulation, etc.

From our examination it would appear that a custom designated nickel-cadmium battery would be the most appropriate power pack for operation at  $-60^{\circ}\text{F}$  and that appropriate batteries can be developed.

### 6.3 ELASTOMERICS

The results of Arthur D. Little's search for information on the low temperature properties of elastomers revealed that there is apparently little information available on the subject of elastomers and rubbers useful for fuel delivery systems under arctic conditions. What information is available points out that elastomers that will function at extremely low

FIGURE 6-2

RELATIVE CAPACITY OF LEAD-ACID STORAGE BATTERIES AT NORMAL AND LOW TEMPERATURES

Temperatures		Percentage of Capacity at 80°F, 20-Hr Rate	
°C	°F	20-Hr Rate	20-Min Rate
27	80	100	46
15	60	90	39
4	40	77	31
-7	20	63	24
-18	0	49	16
-29	-20	35	9
-40	-40	21	1
-51	-60	9	--

FIGURE 6-3

EFFECT OF TEMPERATURE ON THE VISCOSITY OF SULFURIC ACID SOLUTIONS, AND THE LIMITATIONS IMPOSED BY FREEZING POINTS

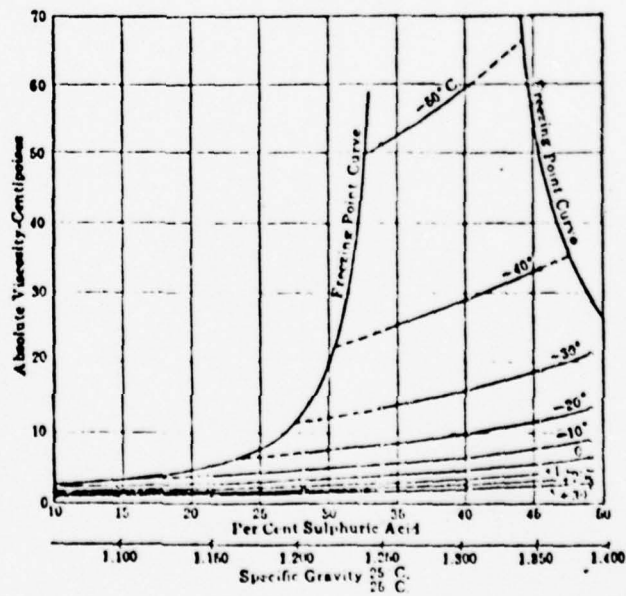

FIGURE 6-4

CAPACITY OF Ni-Cd POCKET CELLS AT DIFFERENT TEMPERATURES AND DENSITIES OF ELECTROLYTE. End VOLTAGES: AT -40 and -30°C. 0.90 V; at 20°C = 0.95. V; at 0 and +25°C. 1.00 V. Curve a. density = 1.30 g/ml; Curve b. density = 1.19 g/ml

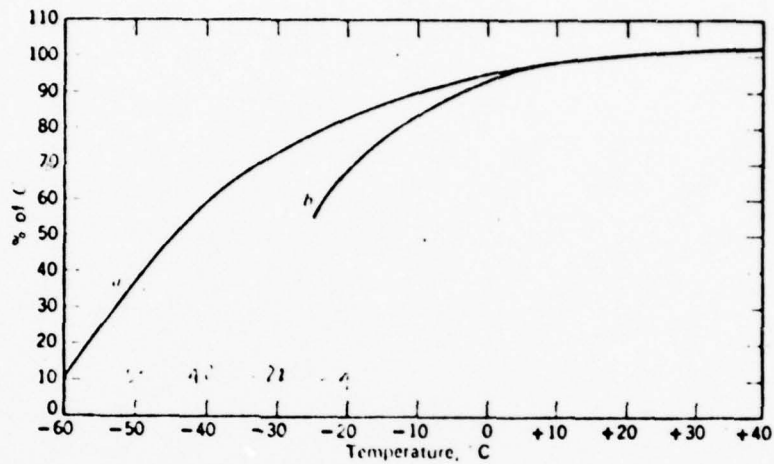

FIGURE 6-5

CAPACITY OF HIGH-RATE Ni-Cd CELLS AT DIFFERENT TEMPERATURES AND LOADS TO A FINAL VOLTAGE OF 0.80 V. DENSITY OF THE ELECTROLYTE 1.21 g/ml. DISCHARGE RATES. CURVE a. 0.1 x CA: DISCHARGE RATES. CURVE b. 0.25 CA: DISCHARGE RATES. CURVE c. 0.5 CA: DISCHARGE RATES. CURVE d. 1.0 x CA: DISCHARGE RATES CURVE e. 2.0 x CA. C = RATED CAPACITY

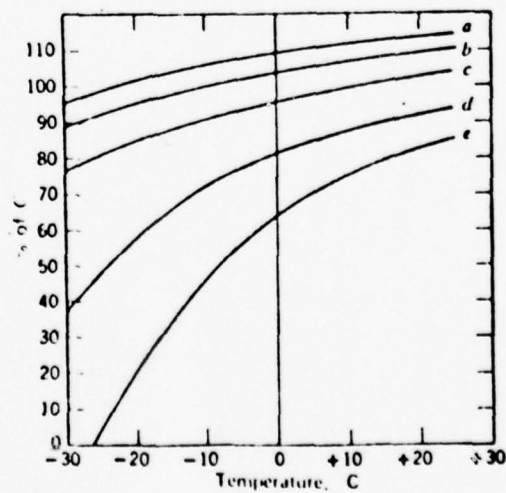
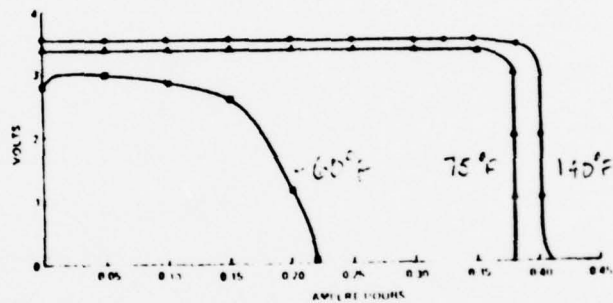

FIGURE 6-6

DISCHARGE OF Li/SOCL<sub>2</sub>:1.8 M LiAlCl<sub>4</sub>/C CELLS  
AT VARIOUS TEMPERATURES



temperatures either do not possess adequate physical strengths or do not possess adequate fuel resistance for long term use in the intended application. The results of Arthur D. Little's research and possible solutions for this application follow. Some products are available now (or may become available shortly) that may be appropriate for the purposes of this mission.

Information on the low temperature properties and chemical resistance of elastomeric materials have been summarized in Figures 6-7 and 6-8. A listing of other physical and mechanical properties of several elastomers is shown in Figure 6-9. The following is a discussion of some properties of elastomers to be considered and a listing of some potentially useful elastomers for materials in the arctic.

- Stiffness of Elastomers at -60°F

When rubbers are exposed to low temperatures, two major effects occur, crystallization and transition into a glassy state. Both effects lead to a large increase in stiffness and a decrease in the usefulness of the rubber at the temperature at which these effects occur. Crystallization is a slow process and is dependent on the polymer chain structure. The glass transition temperature ( $T_g$ ) is rate dependent. Under rapid cycling or cooling the  $T_g$  can be raised considerably. The  $T_g$  is also dependent on the polymer chain structure, compound composition and the incorporation of plasticizers. On prolonged storage at low temperatures above the  $T_g$  or upon slow cooling, certain rubbery materials stiffen due to crystallization.

A useful method for determining the useable low temperature limits of an elastomeric material is the low temperature stiffening point as measured by ASTM D 1053. This test method measures the stiffness of a rubber strip upon the application of an angular torque. In this manner the torsional modulus versus temperature is determined. For most elastomers, a point is reached where the modulus rises rapidly with decreases in temperature. A practical limit has been defined as the point where the modulus reaches about 70 kM/sq. m (10,000 psi) or the  $T_{70}$  value, or 100 kM/sq. m (14,500 psi) the  $T_{100}$  value (where kM = 100,000 kilograms). An alternative approach is to define the low temperature flexibility limit as the point where the torsional modulus reaches 100 times the room temperature value or  $T_R$  value.

These values for a number of elastomeric materials whose  $T_g$  is greater than about -40°F are shown in Figure 6-7 in descending order. From this data, the most useful elastomers in terms of low temperature stiffness at -60°F or lower are the first seven, with the best being the styrene, butadiene, block copolymer, thermoplastic, elastomers and the silicone and

FIGURE 6-7

LOW TEMPERATURE STIFFNESS OF ELASTOMERS

<u>Elastomer</u>	<u>-40°F</u>	<u>-76°F</u>	<u>T<sub>70</sub></u> <u>°F</u>	<u>T<sub>100</sub></u> <u>°F</u>	<u>T<sub>R</sub></u> <u>°F</u>	<u>Trade Names</u>
Thermoplastic	-	171 (-98°F)	-110	-112	-99	Kraton
Silicone	-	171	-81	-85	-81	Silastic
Fluorosilicone	-	711	-80	-81	-87	Silastic
Polyether Urethane	-	1280	-74	-78	-81	Adiprene
Butadiene	-	2133	-71	-74	-74	Diene
Polyester	1792	3001	-	-	-	Hytrel
Chlorobutyl	213	3840	-63	-67	-60	Butyl
Butyl	241	7965	-60	-62	-60	Butyl
EPDM	213	8676	-60	-62	-62	Nordel
Natural Rubber	171	8534	-62	-63	-69	-
Isoprene	270	12800	-60	-62	-65	-
Polysulfide	455	21334	-51	-53	-58	Thiokol LP
SBR	1422	-	-36	-38	-78	-
Chloroprene	2560	-	-35	-36	-80	Neoprene
Nitroso	1707	-	-36	-40	-35	-

Notes:

- T<sub>70</sub> - 70 kM/sq m (10,000 psi)
- T<sub>100</sub> - 100 kM/sq m (14,500 psi)
- T<sub>R</sub> - 100 times room temperature modulus

FIGURE 6-8

CHEMICAL RESISTANCE OF LOW TEMPERATURE ELASTOMER

<u>Elastomers</u>	<u>Minimum Continuous Use Temperature °F</u>	<u>Chemical Resistance</u>		
		<u>Aliphatics</u>	<u>Aromatics</u>	<u>Synlubes</u>
Silicone	-178	P-E	P-E	P-E
Polybutadiene	-150	P	P	P-F
Fluorosilicone	-90	E	E	E
Propylene Oxide	-80	F	P-F	F-G
Epichlorohydrin	-80	E	VG	F-G
Styrene Butadiene	-75	P	P	P
EPDM	-70	P-G	P	F-G
Natural	-70	F	P	P-F
Thermoplastic	-70	P	P	-
Polyurethane	-65	E	F-G	P-G
Isoprene	-60	P	P	P-F
Nitrile	-60	E	G	F-G
Chloroprene	-60	G	F	P
Chlorinated PE	-60	E	P	P
Polynorbonene	-60	P	P	G
Olefinic	-60	F-G	P	G
Copolyetherester	-60	G-E	E	E

FIGURE 6-9

Selection and service guide for rubbers

Common or trade name	Styrene		Polybutadiene		Fluoro-silicone		EPDM		Natural rubber		Epichlorohydrin		GFS or Ziegler-S		Urethane		Butyl		Neoprene		Thiokol	
	MQ, PMQ	VMO, PVMO	FC, FE, GE	BR	AA	FVMQ	FK	AA, BA, CA	NR	AA	CO, ECO	SEI	AU, BU	IR	AA, BA	CR	BC, BE	IR	CR	CR	CR	CR
Chemical type	Poly-siloxane		Equisilene		Fluoro vinyl methyl siloxane		Ethylene propylene diene monomer		Natural polyisoprene		Epichlorohydrin		Styrene-butadiene		Polyester or polyether urethane		Isobutene isoprene		Chloroprene		Polysulfide	
ASTM D 1419 Designation	11-16	25-60	45-80	094	45-80	1.4	40-80	0.86	30-100	0.93	1.06-1.27	0.64	1.05-1.30	0.52	1.24	0.52	1.34	1.24	40-95	0.52	1.24	1.34
ASTM D 2000 CAE J2000 type, class	D	A	B	C	D	A	B	C	A	C	A	C	B	A	B	A	B	A	B	A	B	D
<b>PHYSICAL</b>																						
Specific gravity (polymer)																						
Modulus range (Shore A)																						
Compatibility to Grease																						
Electrical resistivity																						
Color																						
Tensile																						
Neutralizing																						
Demulsibility																						
<b>Mechanical</b>																						
Tensile strength (max psi)																						
Adhesion resistance																						
Flex resistance																						
Tear resistance																						
Impact resistance																						
Compression capability																						
Compression retention																						
Resiliency																						
Creep, stress relaxation																						
<b>THERMAL</b>																						
Recommended max temp (°C)																						
Low-temp stiffening																						
Heat aging resistance																						
Flame resistance																						
<b>RESISTANCE TO</b>																						
Water																						
Oxygen																						
Ozone																						
Radiation																						
Water																						
Steam																						
Acid diluents																						
Acid diluents																						
Oil, gasoline, kerosene																						
Benzene, tetralin																						
Animal, vegetable oils																						
Oxygenated solvents																						
Hydrocarbon solvents																						
Alcohol																						
Synthetic lubes (diester)																						
Hydraulic fluids																						
Greases																						
Fluorocarbons																						

A = Excellent B = Good C = Fair D = Poor NR = Not Recommended

fluorosilicone rubbers. Other potentially useful materials (down to  $-60^{\circ}\text{F}$ ) include the urethane, butadiene, polyester, chloro butyl, butyl, EPDM, and natural and synthetic natural rubbers. The remaining materials will be considerably stiffer under low temperature use conditions.

- Chemical Resistance of Rubber Materials

A number of references were found that list the chemical resistance of various elastomers to aliphatic, aromatic and synthetic lubricant materials. No data was found for the chemical resistance of the elastomers to these materials at low temperatures but generally the reaction is the same, only at greatly reduced rates. Figure 6-8 presents the general chemical resistance characteristics of several of the useful low temperature elastomeric materials. Fuels are considered to be aliphatic in chemical nature.

On the basis of fuel resistance, the fluorosilicone and epichlorohydrin rubbers should receive prime consideration. Other possibly acceptable materials include the silicone polyurethane, EPDM and nitrile rubbers.

- Other Rubber Materials for Consideration

Some other more exotic rubber materials do not appear in either of Figures 6-7 and 6-8 above. This may be because they are not in general use (because of high cost) or were not available for testing at the time of publication of the reference material from which these tables were formulated.

Some comments about these materials and others of interest to MERADCOM are presented below.

- Epichlorohydrin Rubber

Epichlorohydrin elastomers are noted for their resistance to fuel, weathering, and heat, and their low temperature flexibility. There are two types of products produced by the two manufacturers. B.F. Goodrich produces Hydrin 100 and Hydrin 200, while Hercules produces Herchlor H and Herchlor C. In both cases the latter designation is the copolymer with ethylene oxide, which possess the better low temperature properties down to  $-40^{\circ}\text{F}$ . However, the homopolymer has the better oil and fuel resistance. The copolymers can be compounded to retain flexibility as low as  $-65^{\circ}\text{F}$ .

- Polysulfide Rubber

Polysulfide rubbers, developed by Thiokol Chemical Corporation, are generally considered excellent for solvent and fuel resistance. They can be formulated to give a  $T_g$  of  $-104^{\circ}\text{F}$ , but are normally found in the  $-11^{\circ}\text{F}$  to  $-45^{\circ}\text{F}$  range.

- Thermoplastic Elastomers

As noted in Figure 6-7 the thermoplastic elastomers produced by Shell Chemical and Phillips Petroleum under the trade name Kraton have the lowest stiffness temperature or torsional modulus of any of the elastomeric materials. However, their fuel resistance and physical strength properties are not very good in comparison to other materials noted in this report.

- Fluorosilicone Elastomers

The fluorosilicone elastomers provide the best oil and fuel resistance along with excellent low temperature flexibility. The only drawback with their use is poor physical strength properties. They might be useful as an inner fuel resistant liner combined with an outer casing of higher physical property attributes such as the urethane or butadiene rubber materials.

- Carboxy Nitroso Rubber

Carboxy Nitroso rubber (CNR) is a fluorocarbon elastomer developed by Thiokol Corporation for aerospace applications. Originally developed for resistance to strong oxidizing fuels and for flame resistance in pure oxygen, this material has excellent oil and fuel resistance and unusually good low temperature flexibility to  $-38^{\circ}\text{F}$  unplasticized and down to  $-54^{\circ}\text{F}$  with plasticizers. In thin coatings over fiberglass, CNR shows flexibility down to liquid Nitrogen temperature.

- Polyfluorophosphazine (Phosphonitrilic Fluoroelastomer) Rubber

Polyfluorophosphazine, an "inorganic rubber" is being developed by Firestone Rubber Company. Mixing alkoxy substituents into the material gives elastomers with low glass transition temperatures. Fluoro alkoxy substituents provide good resistance to petroleum fluids while offering  $T_g$ 's down to  $-90^{\circ}\text{F}$ . Polyfluoroalkoxyphosphazene (PFAP) can be compounded to be serviceable down to  $-70^{\circ}\text{F}$  with greater physical properties than the only other oil-resistant low temperature elastomer, fluorosilicone rubber.

One specific type of elastomer under the general class of polyfluorophosphazine rubbers of considerable promise is phosphonitrilic fluoroelastomer (PNF). PNF has been worked with to try to develop compounds which could be fabricated into collapsible hoses. Several formulations looked feasible, however, the good low temperature serviceability constraint severely limited the number of reinforced agents. Only relatively large particle size black such as FEF would provide good workability and low temperature flexibility.

Using an FEF black compound, it was demonstrated that large lengths of both collapsible and suction hoses could be manufactured. These hoses showed good flexibility at  $-70^{\circ}\text{F}$ . Furthermore, the hoses possessed very good dimensional stability and physical strength. Rather low tensile and tear strengths were the major deficiencies of these hoses. Low adhesion of tube and cover to inner plies were caused primarily by the low tear strength.

All trial hoses showed good fuel resistance. The final large lengths of hose showed adequate volume swells but high levels of residue from the existent gum test. It appeared that considerable amounts of fuel components were present in the residue along with some low molecular weight PNF. It can be concluded that modified PNF can be used for arctic fuel hose with utility at  $-70^{\circ}\text{F}$  and will therefore meet the temperature requirements of this study. Further studies are needed toward improving tensile and tear strengths and eliminating any low molecular weight material in the polymer.

- Summary of Elastomeric Considerations

The general physical, mechanical and chemical resistance properties of selected elastomeric materials are presented in Figures 6-9 in descending low temperature applicability. A brief description of the selected elastomeric classes in Figure 6-9 is provided in Appendix 4.

Inasmuch as some elastomers at low temperatures possess excellent strength but poor fuel resistance and others have the opposite qualities, it is conceivable that combinations of materials could provide the desired properties. The selection of highly fuel resistant elastomers as an inner liner backed up by stronger, flexible elastomers for the outer casing of fuel lines should work. We have been unable to discover any references combining materials in this manner. Further work with phosphonitrilic fluoroelastomers may produce a suitable material also.

With regard to current off-the-shelf products, Firestone anticipates marketing PNF. The anticipated cost is \$40 per pound. Goodyear's Flexwing (whose composition is not presently known to us)

is \$15 per foot for 2 inch diameter hose and is currently being used in the arctic. Both of these products can be used, but have certain drawbacks such as high cost and weight and in the case of Flexwing no collapsibility. It is anticipated that a suitable development program could improve upon these. Both of these are considered as examples in the final evaluation.

The other elastomeric issue is collapsible fuel tanks. Commercial research on suitable materials for fabrication of collapsible tanks and drums for fuel storage at  $-60^{\circ}\text{F}$  appears to be lacking. Current materials and products are unsuitable for arctic use as intended by the Army and further research is required. PNF may be a possibility though its tear strength (thus adherence to fabric qualities) needs improvement.

The problems of satisfactory materials for use in seals, gaskets, and diaphragms may be less severe. It appears that teflon and PNF may be good materials solutions for such application.

## CHAPTER 7 - FINAL EVALUATION OF ALTERNATIVES

### 7.1 INTRODUCTION

This chapter presents the final evaluation of arctic fuel resupply alternatives. The form of the chapter will emphasize the method of evaluation and reserve the presentation of the recommendations to the last section of this chapter. Actual policy followed by the Army in implementing arctic fuel resupply systems depends somewhat on a final interpretation of the results presented here. For example, the recommendations depend on the sensitivity of MERADCOM to cost. The method of evaluation is therefore presented before the final recommendation.

The method of evaluation is to collapse the numerical ratings on various attributes to a numerical summary vector consisting of four different values. These values comprise:

- Performance Index
- Size and Weight Index
- An Index of Development Risk
- Life Cycle Cost

Because each of these attributes are in themselves extremely important, and because it is difficult to perform a quantitative trade-off among these four attributes, we chose to qualitatively evaluate each system on the merit of the four values for the four attributes above. In this manner, the performance can be assessed without regard for other issues.

As for hosing we compared various state-of-the-art materials with rigid pipe. Certain assumptions were made on how development might improve such products as Goodyear Flexwing in areas such as weight.

### 7.2 STEPS IN ANALYSIS

The final evaluation was performed in three separate steps. In order to more intelligently make the final evaluation, we reduced the final attribute list from 28 to 11. Thus, the first step was a reduction of attribute values to the smaller list. This reduction was performed by combining attributes and eliminating attributes in the case where all the ratings were the same. The following attributes were eliminated as there were no significant differences with respect to the attributes between the competing systems (although there might have been differences when all systems were considered in Phase 1).

- Off-loading Speed
- Lifetime
- Implementation Probability Using Current Technology
- Security
- Vulnerability
- Environmental Compatibility

In addition, the following consolidations were formed:

- A. -60°F and -20°F reliability were combined to a single reliability index.
- B. Probability of developing components, probability of integrating system, and dependence on high cost materials were all combined into a single development risk attribute.
- C. Procurement cost, development cost, fuel cost, manpower cost, and other operating costs were combined into a single life cycle cost numerical value.
- D. Set-up and dismantling time and rough terrain performance were combined into a single attribute.
- E. Dependence of special tools and skills and ease of operation were combined into a single attribute.
- F. Maintenance time and frequency were combined into a single attribute.

Thus, the final list of attributes included

- Response capability
- Reliability
- Fuel Flexibility
- Development risks
- Life cycle cost
- Size
- Weight
- Terrain performance and set-up and dismantling time
- Dependence on special tools and skills and ease of operation
- Ability to stand alone
- Safety
- Maintenance time and frequency

In the second step of the analysis all of the revised attributes were evaluated and where possible actual values were used in lieu of a relative index. Those attributes evaluated by actual values included response capability (minutes), life cycle cost (thousands of dollars over a 10 year period), size (pounds), and weight (cubic feet).

In assigning qualitative ratings to the various performance attributes, it was noted that there were often only minor differences in the competing systems. The final evaluation was designed to identify all differences and hence, the rating scales for each attribute were often expanded to reflect this. An example of this expansion was for reliability. In the first phase of the analysis there was a wide range of reliability. All of the systems in the second phase of evaluation, however, were reliable with relatively small differences. The scale was therefore expanded to reflect these differences. Thus, a range of reliability ratings of 2-5 represents systems that are highly reliable.

In determining the life cycle cost the total capital costs was estimated for the system and added to an estimated operating cost based on a 10 year lifetime and peace time scenario. Under the peace time scenario it was assumed that these systems would be used for training two months out of each year. Thus, for the recirculating system it is assumed that the system will be running 16.7% of the 10 year period. For the other systems it was assumed that for each training month the system would be running 16 hours per day over 2 three day periods. Thus, the systems would be running 96 hours per training month or 192 hours per year and hence about 2.2% of the 10 year period.

In performing this analysis the recirculating system had significantly higher operating costs than the other systems, and this tended to work against the capital cost advantage of this system. The major part of operating costs were fuel consumption. For the recirculating system with a diesel engine using 3 gallons per hour approximately \$5,000 would be expended per year for fuel for the AFARE (based on a fuel cost of one dollar per gallon). Using 9 gallons per hour for FSSP about \$15,000 per year would be spent. It was also estimated that the recirculating AFARE system would incur an additional \$5,000 annually in other operating expenses while the recirculating AFSSP system would incur an additional \$20,000 annually in other operating expenses. (These would be mostly labor). Thus, for the recirculating system, the total annual operating costs were estimated to be \$10,000 for AFARE and \$35,000 for AFSSP. For other systems, the annual operating costs were estimated to be \$3,000 for AFARE and \$12,000 for AFSSP.

The major part of the life cycle costs, of course, is the capital procurement costs. Table 7-1 shows cost estimates for the standard baseline systems with a gas turbine engine. For systems utilizing diesel engines, the data from Chapter 5 were utilized.

For other systems and components, differences from the baseline were costed. As an example, alternative 7 requires a magneto (which is comparable to a generator) and compressed dry nitrogen gas and air motor starting for 1 to 2 minutes to conservatively allow for the 30 second GTE start-up time. The required magneto, air motor and compressed gas accessory equipment cost about \$3,000 to \$5,000 and weigh about 100 lbs. The various costs of components for systems other than baseline are presented in Table 7-2.

TABLE 7-1

## BASELINE SYSTEM COSTS

AFARE

<u>Component</u>	<u>Quantity</u>	<u>Cost (\$)</u>
200 GPM Pump (Carter in quantities of 10)	1	4,000
200 GPM Filter/Separator (Estimate from MERADCOM)	1	3,000
4" Gate Valves (iron) (Quote)	2	410
4" ELS (quote)	2	23
4" TEES (quote)	2	52
4" Y (quote)	1	215
4 x 2 COUP (quote)	3	39
Closed Circuit Nozzles (from MERADCOM)	2	1,200
Miscellaneous, Fitting & Hardware (Estimate)		1,000
20 HP Gas Turbine w/o Battery (Mfg's Information)	1	24,000
Assembly, etc. (Estimate)		6,000
Hoses (Mfg's Information)	360 ft. @ 4" diameter	12,900
Batteries (Estimate)	1	<u>5,000</u>
	Total	57,800

TABLE 7-1 (CONTINUED)

<u>Component</u>	<u>AFSSP</u>	<u>Quantity</u>	<u>Approximate Cost (\$)</u>
Aluminum Pipe (12.50 ft.) (quote)		1596 ft	20,000
Disp. Nozzles (quote)		6	300
4" T (quote)		2	104
2" CAP (quote)		2	10
6" CAP (quote)		14	182
3" CAP (quote)		6	33
6" T (quote)		27	1,350
3" T (quote)		6	120
6" Y (quote)		2	600
6 x 4 RED (quote)		3	72
6" Gate Valve (quote)		30	10,000
4" Gate Valve		3	600
Manifold (Estimate)		1	1,000
600 GPM Pump (Carter)		2	8,000
600 GPM Filter/Separator (MERADCOM)		2	12,000
10,000 Gallon Tanks (Fluorosil) (MERADCOM)		12	84,000
Miscellaneous Hardware (Estimate)			5,000
50 HP Gas Turbine w/o Battery (Mfg's Information)		2	50,000
Assy. etc. (Estimate)			15,000
Batteries (Advanced) (Estimate)		2	10,000
Hoses (Mfg's Information)	740 ft. at various sizes		<u>15,000</u>
			233,000

TABLE 7-2

APPROXIMATE COSTS OF COMPONENTS (NOT INCLUDING DRIVES)  
FOR SYSTEMS OTHER THAN BASELINE

<u>Component</u>	<u>Quantity</u>	<u>Cost (\$)</u>
Minimum Weight Rigid Pipe for AFARE (Extruded Aluminum Seamless Tubing)	360 Ft. or about 500 lbs.	1000
Compressed Gas Starting System	1	4000
Shelter (AFARE)	1	2000
Shelter (AFSSP)	1	6000
Portable Heater	1	5000
Continuous Heater	1	5000
Exhaust Heater	1	4000

Some discussion is worthwhile on the treatment of hosing in the cost and attribute calculation. 360 feet of flexible hosing are required for AFARE and 740 feet are required for AFSSP. The Goodyear Flexwing product weights 1.36 lbs. per foot is rated at 200 psi and costs \$15 per foot for two inch hose. Firestone anticipates that phosphonitrilic fluoroelastomer (PNF) material will cost \$40 per pound. Two-inch discharge PNF hose should weigh about 1.0 pounds per foot and two-inch PNF suction hose should weigh 2.0 pounds per foot. Given present alternatives the Flexwing is considerably cheaper and was used as a basis for AFSSP. For AFARE, weight was a crucial issue, however, and the use of Flexwing could violate weight as well as collapsibility requirements. Reasonable weight can be obtained using PNF as discharge hose and Flexwing as suction hose, as this was used as the basis of cost and weight. It is anticipated, however, that products can be developed in the future that may be even lighter. In this sense, our cost and weight numbers may be conservative, but we cannot predict exactly how much weight can be reduced from hosing.

In addition to life cycle cost and capital cost, we also considered the total development costs on a per system basis. It should be noted that a procurement of 25 to 50 AFSSP systems are envisioned and 50 to 100 AFARE systems are envisioned. Even with a million dollar development, this would result in only an extra 10,000 dollars approximately per system. Hence, development cost will not be a substantial part of total life cycle costs. To account for possible differences, however, we added 5,000 dollars per system for those with relatively low development risk and \$10,000 per system for those with relatively high development risk. The overall life cycle cost was the sum of the capital costs, estimated operating costs, and share of development cost. Total life cycle costs are presented in Tables 7-3 and 7-4.

In the next step of the evaluation the numerous performance attributes were combined into a single performance index. These attributes included response time, reliability, fuel flexibility, set-up and dismantling time and terrain performance, special skills and ease of operation, stand-alone ability, safety, and maintenance time and frequency. The consolidation method is discussed in the next section.

The other consolidation computed in determining the four value vector evaluation of each of the systems was the aggregation weight and size into a single numerical size and weight index. For the AFARE system, the recommended size and weight is a limiting constraint. All of the systems were estimated to be slightly larger and heavier than the design goals. For AFARE the size and weight index was computed to be equal to 10 times the ratio of desired weight (900 pounds) to the actual weight times the ratio of the desired volume (65 cu. ft.) to the actual volume. Thus, a score of 10 represented a system that would meet the size and volume goals. If a system, for example, was 50% in excess of both size and weight goal, the size and weight index would be equal to 10 divided by  $1.5^2 = 4.4$ . For the AFSSP all of the systems were within the weight and volume guidelines (even using current weights for arctic

TABLE 7-3

TRADE-OFF TABLE (FARE)

<u>System</u>	<u>Performance Index</u>	<u>Development Risk</u>	<u>Size &amp; Weight Index</u>	<u>Life Cycle Cost (K\$)</u>
1. Shelter-Portable-Diesel	1	2	4.5	58
2. Shelter-Continuous-Diesel	4.5	4	4.5	49
3. Recirculate-Diesel	6.5	5	6.2	49
4. Shelter-Exhaust-Diesel		Not Applicable		
5. Shelter-Continuous-GTE	5	3	5.9	69
6. Baseline-GTE	9	2	8.0	71
7. Gas Start-GTE	9	2	8.0	70
8. Battery & Gas-GTE	10	1	6.9	75
9. Baseline-Rigid Pipeline	5.5	3.5	8.2	59

TABLE 7-4  
TRADE-OFF TABLE (FSSP)

<u>System</u>	<u>Performance Index</u>	<u>Development Risk</u>	<u>Size &amp; Weight Index</u>	<u>Life Cycle Cost (K\$)</u>
1. Shelter-Portable-Diesel	1	2	10	231
2. Shelter-Continuous-Diesel	4.5	4	10	218
3. Recirculate-Diesel	6.5	5	11	225
4. Shelter-Exhaust-Diesel	2	4	10	224
5. Shelter-Continuous-GTE	5	3	11	258
6. Baseline-GTE	9	2	12	255
7. Gas Start-GTE	9	2	12	253
8. Battery & Gas-GTE	10	1	12	263
9. Baseline-Rigid Pipeline	Not Applicable			

hosing). In this case, this score was set equal to 10 plus an extra point (or two) if either the weight or volume (or both) were somewhat less than competing systems. All the weight and volume indices for AFSSP were 10 or above and were judged to be acceptable. The estimated weights and volumes for the eight systems are presented in Table 7-5.

With regards to hosing, the only practical alternative is the substitution of rigid pipe with flexible connections for AFARE. This would reduce cost by almost \$12,000 (as well as development cost and risk) and the extruded aluminum pipe might save a small amount of weight. However, the rough terrain performance and set-up and dismantling time would be a great deal poorer and reliability might suffer due to the increased number of connections. To formally assess the utility of rigid pipe, we evaluated a ninth system consisting of the baseline system with rigid pipe. It is noted that the advantages of cost and risk are small compared to the performance disadvantage. Thus, the flexible hosing appears to be the logical development choice.

The final step of the analysis was a qualitative evaluation of the remaining four consolidated attribute values. This is discussed in the conclusions.

### 7.3 PERFORMANCE RATING

The score sheet for performance attributes is presented in Table 7-6. In Table 7-7 various methods for weighting these relative scores are presented. The addition was a simple addition of the relative scores. We also considered addition plus an addition to the total score of extra attribute values corresponding to the attributes that were considered especially important. These included response capability and ability to stand alone and, in another related scheme, reliability. (Reliability is certainly an extremely important attribute; however, in one of our schemes we did not add an extra value of that score because all the reliabilities for the system are extremely good and the relative scores show only small degradations in quality.) In another scheme, we utilized the weighting scale developed in Phase I. Finally, in a point reduction scheme we gave each system a score of 100 and took off single points for each minor deficiency and up to 5 points for each major deficiency. Major deficiencies included poor response time. Minor deficiencies included degradations in all other areas except safety. (The range of scores for the recirculating system was obtained by considering the degradation in ability to stand alone as anything from an extra minor deficiency to a major deficiency). The overall performance rating, which consisted of a qualitative assessment of the various weighting schemes, is presented in Table 7-8.

### 7.4 CONCLUSIONS

The values for the 4 attributes for the AFARE and AFSSP systems are presented in Tables 7-3 and 7-4. Our conclusions concerning the various systems are as follows:

TABLE 7-5  
ESTIMATED SIZE AND WEIGHT OF ALTERNATIVE SYSTEMS

	AFARE		AFSSP	
	<u>Size(Cu.Ft.)</u>	<u>Weight(Lbs)</u>	<u>Size(Cu.Ft.)</u>	<u>Weight(Lbs)</u>
1. Shelter-Portable-Diesel	103	1,220	1076	23,200
2. Shelter-Continuous-Diesel	103	1,220	1076	23,200
3. Recirculate-Diesel	80	1,180	1000	23,100
4. Shelter-Exhaust-Diesel	-	-	1076	23,200
5. Shelter-Continuous-GTE	98	1,010	1053	21,900
6. Baseline-GTE	75	970	978	21,800
7. Air Start-GTE	75	970	978	21,800
8. Battery and Air-GTE	79	1,070	986	22,000
9. Baseline with Rigid Piping replacing hosing	75	950	-	-

TABLE 7-6  
SCORESHEET FOR PERFORMANCE ATTRIBUTES

System	Response Time*	Reliability		Fuel Flexibility	Set & Dismantling Time and Terrain Performance		Special Skills & Ease of Operation	Stand Alone Ability	Safety	Maintenance Time and Frequency
		Reliability	Flexibility		Time	Performance				
1. Shelter-Portable-Diesel	30(0)	2	1	1	3	3	3	5	3	5
2. Shelter-Continuous-Diesel	1(5)	2	1	1	3	3	5	4	4	3
3. Recirculate-Diesel	0(5)	5	1	1	5	5	5	3	5	3
4. Shelter-Exhaust-Diesel**	30(0)	3	1	1	3	3	5	5	4	3
5. Shelter-Continuous-GTE	1(5)	2	5	5	3	3	5	4	4	3
6. Baseline	5(4)	3	5	5	5	5	5	5	5	5
7. Gas Start-GTE	1(5)	3	5	5	5	5	5	5	5	5
8. Battery & Gas-GTE	1(5)	4	5	5	5	5	5	5	5	5
9. Baseline with hose changed to rigid pipe †(5)		2	5	5	2	2	5	5	5	4

\* Actual time in minutes, relative score in parenthesis

\*\* AFSSP only

† AFARE only

TABLE 7-7  
 COMBINED PERFORMANCE RATINGS USING VARIOUS WEIGHTING SCHEMES

System	Addition	Additon, but Doubling of Response Capability, Reliability & Ability to Stand Alone	Old Scale	Addition, but Doubling of Response Capability & Ability to Stand Alone	Point Reduction Scheme
1	22	29	382	27	89
2	27	38	467	36	93
3	32	45	572	40	93 - 96
4	24	32	419	29	91
5	31	42	499	40	94
6	37	49	600	46	97
7	38	51	620	48	98
8	39	53	652	49	99
9	33	45	546	43	95

TABLE 7-8  
OVERALL PERFORMANCE RATING (Out of 10)

1. Shelter-Portable-Diesel	1
2. Shelter-Continuous-Diesel	4.5
3. Recirculate-Diesel	6.5
4. Shelter-Exhaust-Diesel	2
5. Shelter-Continuous-GTE	5
6. Baseline-GTE	9
7. Air Start-GTE	9
8. Battery and Air Start-GTE	10
9. Baseline-GTE with hose replaced by rigid Connections	5.5

1. For AFARE, the systems that perform very well and come closest to meeting the size and weight restrictions are the baseline systems utilizing a gas turbine engine. One alternative uses advanced batteries, a second uses a gas start and magneto. These systems are more expensive and require more development than many others, but are really the only ones that approach the size and weight restrictions. The recirculating system using a diesel engine costs less and performs reasonably well, but it is heavier and larger.
2. For the AFSSP, the highest performing systems are the same as for the AFARE system. However, again these systems are more expensive and involve more development risk than some others. Unlike the AFARE, however, the competing diesel systems are within the size and weight restrictions. In particular, the shelter with continuous heating and a diesel engine is substantially less expensive than the GTE systems and performs reasonably well. Although the performance index is only 4.5 compared to 9 the performance did not suffer significantly in any category. Consequently, this sheltered diesel system is a reasonable alternative and is less expensive. (The recirculating systems turn out to be nearly as expensive as a GTE system because of the high operating costs.)
3. Reliability and performance on all of the competing systems (with the possible exceptions of the shelter with a portable or exhaust heating) are good performers and are highly reliable. The best performing system, of course, is a baseline system with both advanced battery and a redundant gas start. If the Army wishes to maximize performance this system should be chosen for AFSSP. For AFARE this system also maximizes performance but raises costs and adds additional size and weight where size and weight are constraining limitations.

In evaluating the numbers in Tables 7-3 and 7-4, the decision-maker can treat the multi-attribute evaluation in several ways. He can attach weights to reflect his utility for each attribute. He can evaluate performance and size and weight index without a great deal of regard for cost and development risk. Finally, he can subjectively evaluate the numbers. We cannot determine precisely the utility that MERADCOM places on the four sets of numbers and we hesitate to formulate weighting functions. Performance and size and weight indices, however, appear to be more important than cost. On this basis we would recommend the baseline systems with either a gas start or advanced batteries or both, and we would rank order the alternatives according to the performance index. As far as size and weight restrictions for AFARE are concerned, MERADCOM must make a utility judgement with respect to size and weight index and consider the options cited in comment under two above.

## CHAPTER 8 - RECOMMENDATIONS OF FUTURE DEVELOPMENT AND TESTING REQUIREMENTS

This study has affirmed that the current FSSP and FARE systems in the Army inventory will not work satisfactorily at temperatures below  $-25^{\circ}\text{F}$  and the need exists for arctic refueling systems at temperatures down to  $-60^{\circ}\text{F}$ .

As the previous chapters of this study discuss, there are several components of arctic fuel dispensing equipment systems needing further development and testing to enable the most desirable system alternatives to be effective. These include elastomerics, advanced batteries, adaptation of gas turbine engines as pump drives and fuel filter/separators in the systems. Each shall be discussed in turn. The questions of tactical vulnerability and survival should be resolved also.

- Elastomeric Materials

Elastomeric components are needed for flexible hose requirements, for collapsible tanks and drums and for seals and gaskets throughout the systems. To meet volume and weight limitations for these systems, further elastomeric development and testing is required to provide collapsible discharge hosing which will remain flexible at  $-60^{\circ}\text{F}$ . It is vital that the hose material that is finally developed meet tensile and tear strength criteria and that it neither contaminate the fuel nor be contaminated by the fuel. The two inch collapsible hosing should weigh less than 1 lb. per foot if possible. Suction hosing made of the same material with additional reinforcement should weigh only slightly more. This would minimize hose weight, an item critical particularly for the AFARE. Current work in phosphonitrilic fluoroelastomer compounds is encouraging for this application.

Research is vitally needed to develop and test elastomeric material which would lend itself to fabrication of collapsible fuel storage tanks and drums that would remain flexible at  $-60^{\circ}\text{F}$ . These collapsible fuel containers must be capable of discharging 95 percent of their fuel contents and being folded up, transported to another location, unfolded, installed and filled with fuel, all at  $-60^{\circ}\text{F}$ . The tensile and tear strength of this material must meet criteria and the material must resist contaminating the fuel contents or being contaminated by the fuel. Little

research activity on elastomeric materials for this application appears to be in progress.

It appears that seals, gaskets, and diaphragms can be fabricated of teflon, PNF and certain other materials currently available which will remain flexible and will function satisfactorily at  $-60^{\circ}\text{F}$ . These items should be finally developed and tested for use in the fuel dispensing systems.

- Advanced Batteries

Nickel-cadmium advanced batteries appear to be the most practical type of battery to employ for arctic fuel dispensing systems. A battery cell heating arrangement should be included in these battery systems to provide a more reliable, longer lasting battery component.

- Pump Drive Systems

The most practical pump drive equipment for use in the arctic fuel dispensing system appears to be the gas turbine engine. Such equipment in varying sizes has been developed and it is a matter of manufacturing these engines in the required sizes with the appropriate power train for applying power from the engines to the pumps. These engines can be started either by advanced batteries discussed above or by air starter motors driven by compressed dry nitrogen gas. Such air motor starting equipment may be designed using current commercial technology for this role. The gas turbine engines are light, require little weather protection, and burn multiple fuels.

- Fuel Filter/Separator Units

The Army should proceed with the research and development required to provide F/S units for these systems which will filter unclean fuel products to the required military specifications at  $-60^{\circ}\text{F}$ . This includes removal of ice particles without interference to the other filtering and separating action. Considerations should be given to simplicity requirements for cleaning and maintaining these units by operating personnel at remote locations in the field. These units should be wheel-mounted for ease of positioning in the field, particularly when loaded with fuel being dispensed.

- Tactical Security Measures

Both the AFSSP and the AFARE systems are vulnerable to detection by IR detector equipment and by the equipment noise generated while operating. The locations of these fuel supply points can also be exposed by the traffic patterns of vehicles being refueled, particularly AFARE exposure during heavy helicopter

operations. Both equipment and operators are vulnerable to enemy explosive munitions.

Though vulnerability to enemy action is a common problem in wartime, the fuel dispensing systems may be important enough to warrant the Army's further study and development of procedures, material and equipment designs which would significantly lessen detection from IR equipment, engine noise, and visual sightings and lessen damage or loss from enemy munitions or personnel. Protective coatings, camouflage netting, equipment noise dampening devices, and armour protective coverings would be investigated. Added system weight, however, must be continually watched in such development.

Physical security from direct enemy attack, sabotage, or pilferage is a problem similar to that faced by other military facilities having control over such highly attractive targets. Protective security forces must be figured into military operations involving these systems as well as deceptive maneuvers, continuous supply point relocations, and refueling and deployment schemes.

- Testing Requirements

We realize that the U.S. Army has prescribed standard specification and testing requirements for new materials, equipment and operating systems. Therefore, this study will not make detailed recommendations in those areas. References in this chapter to testing simply mean that testing of newly developed components and systems should be done in accordance with standard military procedures and would include, of course, cold weather field testing of both new components and complete arctic fuel dispensing systems at temperatures down to -60°F.

APPENDIX 1

OPERATIONAL REQUIREMENTS FOR ACCEPTABLE AFDE SYSTEMS

1. GENERAL REQUIREMENTS APPLICABLE TO BOTH AFSSP AND AFARE SYSTEMS:

A. Air and Ground Transportable as follows:

1. AFSSP systems deployable by either ground transportation or C-130 aircraft.
2. AFARE systems deployable by either of those means and also deployable by Army utility helicopters.
3. Systems need to be light, packaged in a small volume and rugged.

B. Able to operate at  $-60^{\circ}\text{F}$  temperature and under other severe arctic weather conditions. Able to be stored at those temperature extremes with no detriment to immediate use.

C. Simple to operate in extreme cold and designed to accommodate equipment operators wearing arctic mittens.

D. Protected against static electricity and containing adequate features to provide maximum safety to operating and maintenance personnel.

E. Capable of storing/issuing all types of military hydrocarbon fuels (i.e., arctic and regular grades, alternate fuels presently available and anticipated fuels).

F. Can be operated tactically under both daylight and night conditions.

G. Equipped with storage tanks which will allow a minimum of 95% evacuation of fuels and which will not fail in the extreme cold.

H. Employing piping which is: light, easily packaged for transportation with a minimum volume; easily assembled (connected) and disassembled under tactical conditions; satisfactory when stored, transported or used at  $-60^{\circ}\text{F}$ ; easily repaired or replaced; non-corrosive or contaminating to fuel; and adaptable to rugged, variable terrain. If hoses are used, they can be coiled and remain flexible for immediate use when uncoiled at temperatures of  $-60^{\circ}\text{F}$ .

I. Pumps which can be placed into immediate operation and having pump drive equipment which is reliable and can be started easily. Noise reduction should be considered.

- J. Gaskets, seals, and O-rings which do not deform, deteriorate, or fail under repeated use in extreme cold and which seal properly in use.
- K. Connections which are simple and quick to operate for pipe jointing and joining pipe fittings and accessories (i.e., adaptors, valves, couplings, reducers, connectors).
- L. Nozzles which are simple to operate and whose seals, gaskets, and components will not leak, deteriorate, or fail in the extreme cold.
- M. Filter/separators which will operate efficiently without clogging or freezing in the cold.
- N. Features providing maximum protection from fragmenting munitions.
- O. Equipped with dual inlet/outlet ports, manifolding, and metering devices.
- P. Systems and components selected which:
  - 1. Have a high reliability
  - 2. Require an absolute minimum of special tools, equipment, spare parts, or lubricants.
  - 3. Are easily repaired and maintained.
  - 4. Are cost effective.
  - 5. Are reasonably resistant to seismic activity or shock impact from battlefield explosions.
  - 6. Are reasonably quiet in operation for military security.
  - 7. Are reasonably secure from pilferage.
  - 8. Can be stored, transported, assembled, disassembled, operated, and maintained using minimum manpower.

2. ATTRIBUTES AND REQUIREMENTS APPLICABLE TO AFSSP

- A. Can be set up in one to two hours.
- B. Must provide 60,000 to 120,000 gallons storage preferably using collapsible tanks/drums.
- C. Should weigh approximately 27,000 pounds and occupy a cube of about 1,700 cubic feet.

- D. Have capability to simultaneously load and unload four bulk fuel transporters including 5,000 gallon tankers, railcars, bladder birds, GOER's and tank and pump units; can dispense fuel to 600-gallon pods, 500-gallon nonvented collapsible drums, 55-gallon drums, and 5-gallon cans; and can issue directly to mobile fuel consuming equipment. Employs a 600 GPM pump at 225 feet head.
- E. Can be divided into a complete two product storage and dispensing facility.

3. ATTRIBUTES AND REQUIREMENTS APPLICABLE TO AFARE

- A. Can be set up by two to three men in 30 minutes to an hour.
- B. Preferably utilize 500-gallon collapsible tanks capable of being sling-lifted by helicopters to forward emplacement areas.
- C. Can be deployed primarily by utility helicopters.
- D. System should weigh approximately 900 pounds (excluding collapsible tanks) and occupy a cube of about 65 cubic feet.
- E. System capable of being filled from an AFSSP, any type of bulk fuel tanker, and a bladder bird.
- F. System must be capable of refueling two medium helicopters simultaneously at a rate of 50 GPM to 300 GPM with closed circuit and/or open port refueling (for other equipment in addition to aircraft as required). Current thinking, however, involves employing 200 GPM pumps at 325 to 375 foot head.

APPENDIX 2

SOURCES OF INFORMATION AND REFERENCES

## SOURCES OF INFORMATION AND REFERENCES

### I. Sources of Information

- A. U. S. Army Cold Regions Test Center, Ft. Greeley, Alaska.  
(Tele. 907-872-4201)
- B. U. S. Support Force Antarctica, Port Hueneme, California.  
(Tele. 805-982-3198)
- C. Holmes & Narver, Inc., Antarctic Support Division, Orange, California.  
(Tele. 714-973-1100)
- D. 222<sup>d</sup> U. S. Army Aviation Battalion, Ft. Wainwright, Alaska.  
(Tele. 907-353-6270)
- E. U. S. Army Combat Developments Activity, Alaska, Ft. Richardson,  
Alaska.  
(Tele. 907-863-1201)
- F. Gilbertson Chevron Bulk Oil Dealer, Delta Junction, Alaska.
- G. Jackovich Tractor & Equipment Company, Fairbanks, Alaska.  
(Tele. 907-456-4414)
- H. Director of Installations Office (Mr. Hebert, Chief POL Section),  
Ft. Greeley, Alaska.
- I. Director of Installations Office (Lt. Hitz/SFC Crawford, Petroleum  
Division), Ft. Richardson, Alaska.  
(Tele. 907-863-3217)
- J. Nabors Alaska Drilling, Inc., Anchorage, Alaska.  
(Tele. 907-278-2511)
- K. C.M.G. Equipment Company, Anchorage, Alaska.  
(Tele. 907-344-0592)
- L. Alaska Airlines, Anchorage, Alaska.  
(Tele. 907-243-3300)

- M. Naval Civil Engineering Laboratories, Advanced Marine Fueling,  
(Mr. Clark Hoffman), Port Hueneme, California.  
(Tele. 805-982-3308)
- N. HQ U. S. Army Aviation Research and Development Command, Directorate  
for Development and Engineering (Mr. Herb Jones), St. Louis,  
Missouri.  
(Tele. 314-268-5828)
- O. Parker Seals Company, Lexington, Kentucky.  
(Tele. 606-269-2351)
- P. Goodyear Tire & Rubber Company, Sales Office, Kent, Washington.  
(Tele. 206-854-3380)
- Q. Gates Rubber Company, Denver, Colorado.  
(Tele. 303-744-1911)
- R. Goodyear Tire & Rubber Company, Akron, Ohio.  
(Tele. 216-794-2121)
- S. Firestone Rubber Company, Central Research Laboratories, Akron, Ohio,  
(Dr. David Tate)  
(Tele. 216-379-6445)
- T. U. S. Army Cold Regions Research and Engineering Laboratory, Hanover,  
New Hampshire.  
(Tele. 603-643-3200)
- U. Uniroyal, Inc., Mishawaka, Indiana, (Mr. C. Kennedy)  
(Tele. 219-255-2181)
- V. L.T.S. Sales, Ltd., (W. Jones), Mississauga, Ontario, Canada.  
(Tele. 416-678-2131)
- W. U. S. Army Natick Laboratories, (H. Madrick), Natick, Massachusetts.  
(Tele. 617-653-1000, Ext. 2546)

- X. U. S. Army Human Engineering Laboratories, Aberdeen, Maryland,  
(Ms. M. Glumm).  
(Tele. 301-278-5201)
- Y. SAFT Corporation, Industrial Battery Division, (E. Beck), Boonton,  
New Jersey.  
(Tele. 201-334-0700)
- Z. U. S. Air Force Electronic Systems Division, Hanscom AFB,  
Massachusetts.  
(Tele. 617-861-2815)
- AA. U. S. Air Force Dewline Office, (W. Evans), Colorado Springs,  
Colorado.  
(Tele. 303-591-4929)
- BB. Felec Services, Inc. (FSI), (G. Dunnells), Colorado Springs,  
Colorado.  
(Tele. 303-574-5850) (Dewline Operations Contractor)
- CC. American Biltrite, Inc., Boston Industrial Products Division,  
(R. Lord), Cambridge, Massachusetts.  
(Tele. 617-876-6000)
- DD. Reynolds Aluminum Company, Wellesley Hills, Massachusetts, (F. Cerny).  
(Tele. 617-237-5143)
- EE. U. S. Army Mobility Equipment Research and Development Command,  
Fort Belvoir, Virginia.  
(Tele. 703-664-(EXT))
- T. Jefferson--Ext. 5382
- C. Browne--Ext. 5781
- P. Touchet--Ext. 5488
- L. Medler--Ext. 4458
- W. McGovern Ext. 5459
- FF. Atlantic Research Corporation, Gainesville, Virginia (G. Hamm)  
Telephone 703-754-4111

## REFERENCES

### CHAPTER 1

1. MERADCOM, Statement of Work, Contract DAAK-70-77-D-0024, December 27, 1978.
2. Department of the Army, letter ATCD-S-L, "Letter of Agreement for Arctic Fuel Dispensing Equipment" (AFDE) System, USATRADOC ACN 22857, July 27, 1978.

### CHAPTER 2

1. Decisions with Multiple Objectives, R.L. Keeney and H. Raiffa, J. Wiley, 1976

### CHAPTER 3

1. Department of the Army TM 10-1101, "Petroleum Handling Equipment and Operation," May 1972.
2. Department of the Army publications titled "Bulk Petroleum Facilities and Systems (BPFS) -- 1970 - 1985," November 1969 (5 parts):
  1. Phase 1: 1970-1985, Main Report
  2. Phase 1: 1970-1975, Annex A, Historical and Doctrinal Review
  3. Phase 1: 1970-1975, Annex B, Part 1: Military Equipment Survey
  4. Phase 1: 1970-1975, Annex B, Part 2: Industry Equipment Survey
  5. Phase 2: 1975-1985
3. Department of the Army TM 55-2330-203-25P, "Transporter, Liquid, Rolling Wheel Type," 1000 Gallon, M6, January 1963.

### CHAPTER 4

1. Department of the Army, FM 9-207, "Operation and Maintenance of Ordnance Material in Cold Weather (0° to -65°F)," January 1978.
2. US Army Cold Regions Test Center Booklet, "Man and Material in the Cold Regions," (Part 1), received February 1979.
3. Department of the Army FM 31-70, "Basic Cold Weather Manual," dated April 1968.

REFERENCES (CONTINUED)

4. U.S. Air Force Aero Propulsion Laboratory AFAPL-TR-78-89, "Factors Affecting Electrostatic Hazards," December 1978.
5. MIL-STD-1472B, "Human Engineering Design Criteria for Military Systems, Equipment and Facilities," December 31, 1974.
6. MIL-HDBK-759, "Human Factors Engineering Design for Army Material," March 12, 1975.
7. US Army Cold Regions Test Center - Test Reports
  - a. ADB010-459L Feasibility Test of Anti-Contact Insulation Kit for Gravity Nozzle, April 1976.
  - b. AD833-458L Service Test of Tank Collapsible 1250 Barrel, April 1968.
  - c. AD821-538L Service Test of Filter/Separator 350 GPM, April 1967.
  - d. AD815-630L Service Test of Filter/Separator 50 GPM, March 1967.
  - e. AD835-548L Confirmatory Test of M-6 Rolling Liquid Transporter, June 1968.
  - f. AD471-782L Service Test of Container, Fuel, Military Bulk - 340 Gallon Capacity
  - g. AD414-413L Service Test of Truck, Tank, Fuel - 5,000 gallons 4x4 XM438E2, August 1963.
  - h. AD402-949L Service Test of Aircraft Auxiliary Fuel System XII, April 1963.
  - i. "Special Study of Low Temperature Fuel Hose," April 1978.

CHAPTER 5

1. Decisions with Multiple Objectives, R.L. Keeney and H. Raiffa, J. Wiley, 1976.

CHAPTER 6

1. N-78 18432 "Phosphonitrilic Fluoroelastomer Fuel Hose Utilization of Extruded Tubes," Firestone Central Research Laboratories, October 1977, AD AD47960, Report No. 1432-2.
2. N-77 28306 "Fabrication of a Low Temperature Fuel Hose from Phosphonitrilic Fluoroelastomer," Firestone Central Research Laboratories, November 1976, ADA036903, Report No. 1432-1.

#### REFERENCES (CONTINUED)

3. Rubber Chemistry and Technology, Vol. 49, No. 2, May - June 1976, "Phosphazene Elastomers for Fuel Service Under Arctic Conditions," USA MERADCOM, Fort Belvoir, Virginia.
4. Rubber Chemistry and Technology, Vol. 47, No. 1, March 1974, "Phosphonitrilic Fluoroelastomers - A New Class of Solvent Resistant Polymers with Exceptional Flexibility at Low Temperature," Firestone Central Research Laboratories, Akron, Ohio.
5. At Low Temperatures: Which Rubbers are Flexible? Materials Engineering, December 1972.
6. Rubber and Elastomers, Materials Engineering, December 1978.
7. Selection and Service Guide for Rubbers, Machine Design, March 1979.
8. Hygiene for Precision Equipment: Boots and Way Covers, Machine Design, February 1979.
9. Relative Performance of Rubbers and Elastomers, Materials Engineering, July 1974.
10. Elastomers: More Versatile than Ever, Plastics World, December 1976.
11. Epichlorohydrin Elastomers Resist Environmental Extremes, Materials Engineering, July 1975.
12. B.F. Goodrich Data Sheets: Hydrin Epichlorohydrin Elastomers, Sections 1 - 9.
13. Hercules Technical Data: Herchlor Rubbers
14. Polyphosphazene Elastomers, Firestone Central Research Laboratories, J. Polymer Sci., Symposium No. 48, 1974.
15. Chemistry and Technology of Elastomeric Polysulfide Polymers, Thiokol Chemical Corp., Rubber Chemistry and Technology, Vol. 41, No. 1, February 1968.
16. Carboxy Nitroso Rubbers, Thiokol Chemical Corp., Rubber Age, May 1969.
17. Elastomers and Rubbers, Machine Design, March 1979.

#### CHAPTER 7

1. Decisions with Multiple Objectives, R.L. Keeney and H. Raiffa, J. Wiley, 1976.

APPENDIX 3  
BACK UP MATERIAL FOR PUMP DRIVES

# SOLAR

## Model T-62T-32-1 Titan Auxiliary Power Unit

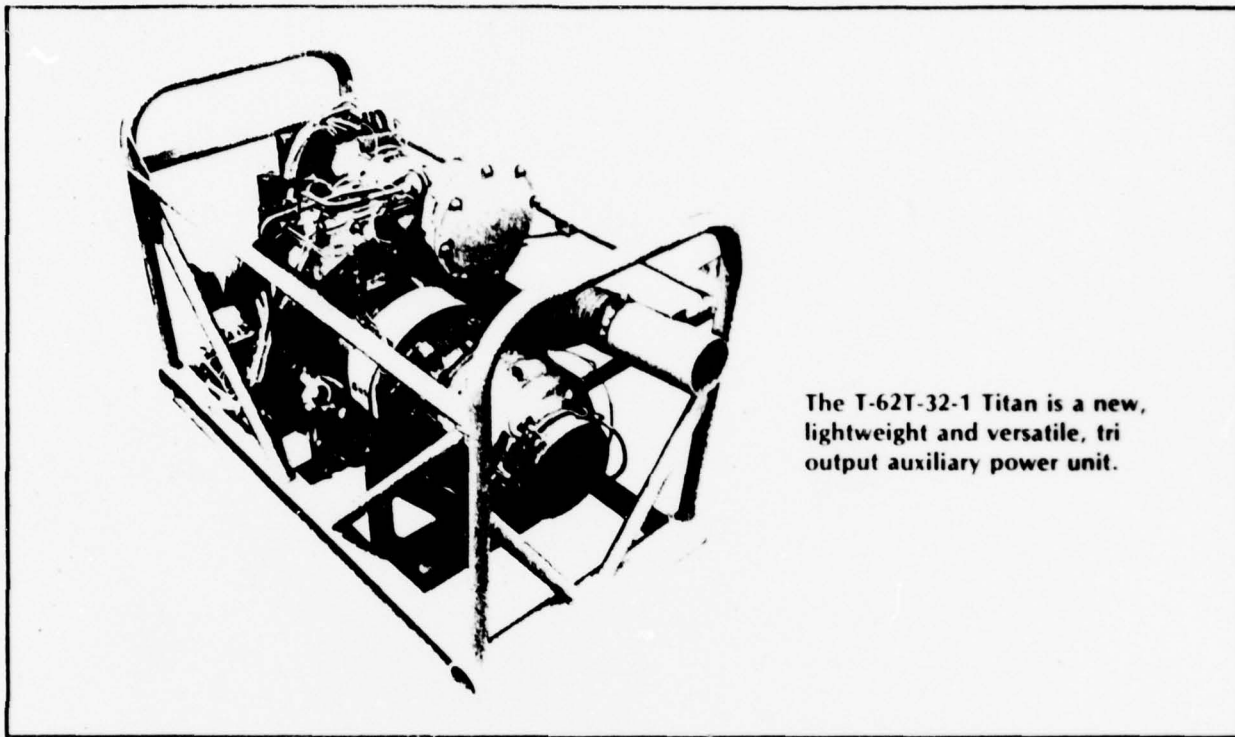

The T-62T-32-1 Titan is a new, lightweight and versatile, tri output auxiliary power unit.

### Performance Data

#### Rating at 59°F, Sea Level [14.7 psia]\*

- Primary power pad - 60 kW, 3 $\phi$  400 Hz, 120/208 vac
- Starter/generator pad - 9 kva, 30 vdc, 300 amps
- Power take-off pad - 30 shp with 9 kva load on starter/generator or 43 shp with no load on starter/generator

\*ISO rating with ac generator and dc starter/generator installed

#### Multi-Fuel Capability

CIE-MIL-F-45121  
MIL-F-16884 VV-F-800, Diesel  
MIL-G-3056, Motor Gasoline  
MIL-G-5572, AVGAS  
MIL-J-5624, JP-4 and JP-5  
VV-K-211, Kerosene

#### Oils

MIL-L-2104, MIL-L-7808,  
MIL-L-10295, MIL-L-23699

#### Output Pads

- 6000 rpm, primary ac power, AND-20006 Type XVI-B

- 6000 rpm, combination starter and dc generator, AND-10262
- 3250 rpm, power take-off, suitable for hydraulic pump, AS469B

#### Engine Rotor Speed

61,091 rpm

#### Maximum Continuous Temperature [Full Load]

Up to 1180°F EGT

#### Weight

440 lb includes engine and gearbox, starter and generator, and tubular frame. Other mounting frames may be substituted for this tubular frame.

#### Maximum Fuel Consumption [60 kW]

105 pph

#### Generator

- Frequency regulation - 0 to 3% adjustable  $\pm$  Hz
- AC voltage regulation - 0.5% at constant load
- DC voltage regulation - 0.75% at constant load
- Frequency adjust range - 388 to 412 Hz
- AC voltage adjust range - 95 to 110% of rated load
- DC voltage adjust range - 25 to 31 volts

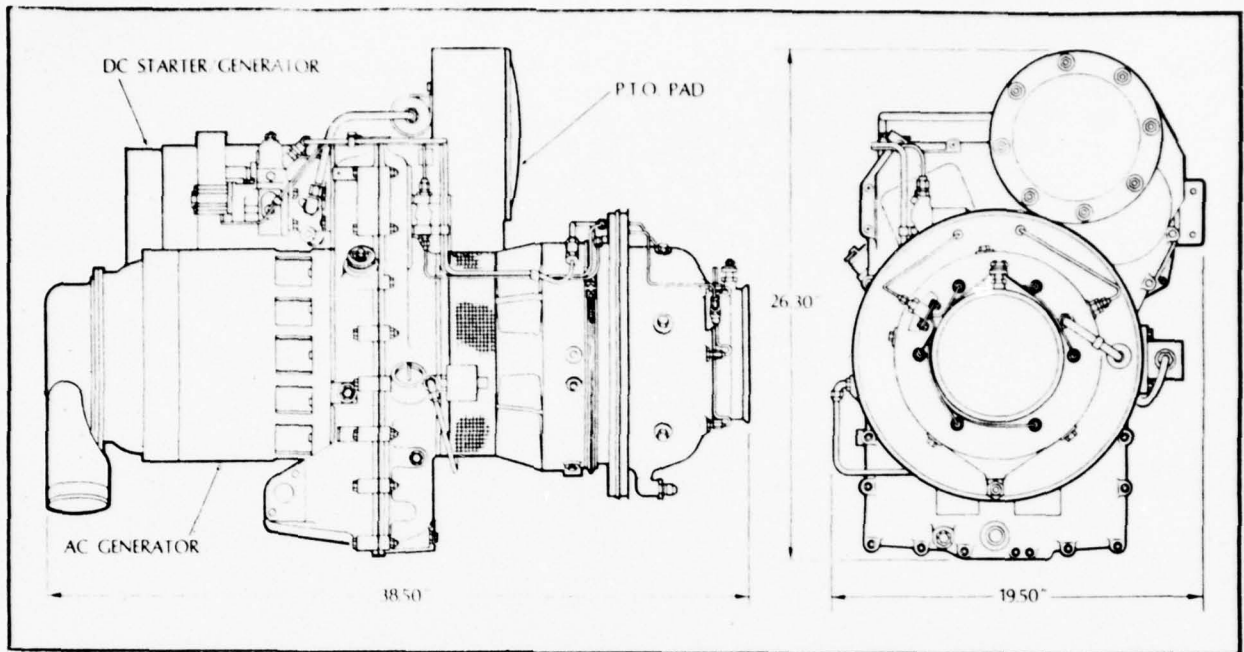

## Standard Features

- Annular Combustor
- Automatic Acceleration Control
- Automatic Start, Solid State Speed Sequencing
- Cold-End Drive
- Fully Automatic Control System
- Integral Oil System
- Low Oil Pressure Protection
- Overspeed Protection
- Overtemperature Protection
- Paralleling Capability between Two Sets
- Single-Stage Radial Compressor
- Single-Stage Radial-Inflow Turbine
- Starts within 30 Seconds from -65 to 130°F

## Standard Accessories

- EGT Thermocouple
- Electric Starter
- Fuel Control
- Fuel Filter
- Ignition System
- Isochronous or Droop Control
- Local and Remote Panels
- Magnetic Speed Pickup
- Oil Filter
- Oil Pressure Regulator
- Oil Pressure Switch
- Overspeed Switch
- Overtemperature Switch
- Reverse Current Protection, AC and DC
- Solid State Speed Sequencing and Temperature Control Unit
- Underfrequency
- Undervoltage



For more information, write:  
Solar Turbines International  
Department 790  
Radial Engine Division

# SOLAR TURBINES INTERNATIONAL

An Operating Group of International Harvester  
2200 Pacific Highway P.O. Box 80966 San Diego, California 92138

The words *Solar* and *Titan* appearing herein are trademarks registered by International Harvester Company in the U.S. Patent Office  
T21S-32/1178

# PRELIMINARY GAS TURBINE SPEC DATA

MODEL

# GTP36-51

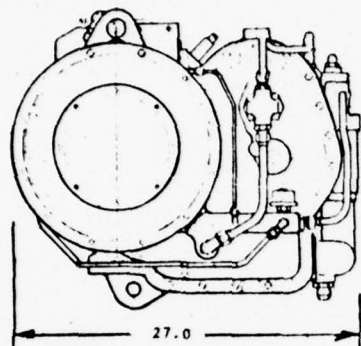

ENVELOPE DATA

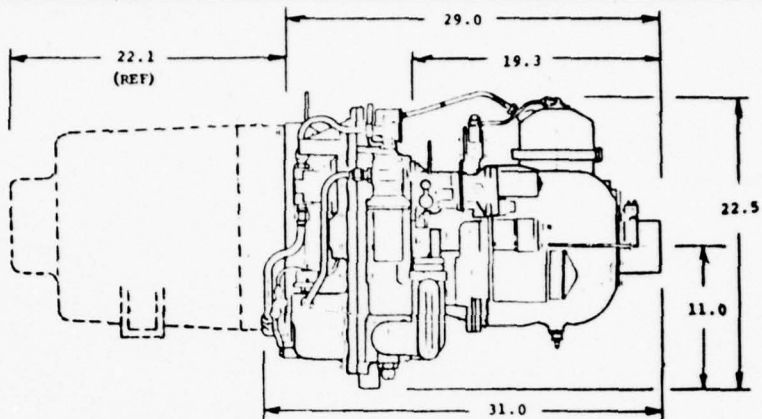

NOTE: DIMENSIONS ARE APPROXIMATE

WEIGHT: (W/GEARBOX & ACCESSORIES) 370 LB. (DRY)

INLET AREA: 50.0 SQ. IN.

EXHAUST AREA: 12.5 SQ. IN. (4 IN. DIA.)

## PERFORMANCE DATA AND LEADING PARTICULARS:

FUELS: KEROSENE (JET FUELS) AND DIESEL FUELS. UNLEADED GASOLINE, LEADED GASOLINE (EMERGENCY)

OILS: NUMEROUS MINERAL AND SYNTHETIC OILS ARE APPROVED

DIRECTION OF ROTATION: CCW (FACING OUTPUT PAD)

SHAFT HP: (SEA LEVEL, 60°F DAY)  
 \*○ CONTINUOUS DUTY: 75 HP  
 \*\*○ STANDBY DUTY: 82 HP

SPEED: 80,000 RPM

\*CONTINUOUS DUTY. THE RATING FOR LONG-LIFE ECONOMICAL PERFORMANCE WITH CONTINUOUS HEAVY DUTY LOADS.

\*\*STANDBY DUTY. THE MAXIMUM HORSE-POWER OBTAINED WITH REDUCED LIFE, WITHOUT SIGNIFICANTLY DEGRADING ENGINE RELIABILITY.

## STANDARD FEATURES:

- FULL CONTAINMENT-COMPRESSOR AND TURBINE
- SINGLE CAN - FIELD REPLACEABLE COMBUSTOR
- IGNITION SYSTEM - LOW ENERGY
- LUBE SYSTEM - EXCEPT HEAT EXCHANGER
- FUEL SYSTEM - LOW PRESSURE
- OVERSPEED AND OVERTEMP PROTECTIVE SENSORS (MONOPOLE AND THERMOCOUPLE)
- ELECTRICAL STARTER - 24 VDC
- OUTPUT PAD - SAE J617a-4
- OUTPUT PAD SPEED - 3600/3000 RPM, BUILT-IN GEAR CHANGE
- 3 $\frac{1}{2}$  SPEED ADJUSTMENT
- OIL LEVEL DIPSTICK
- CAST PARTS - TURBINE AND COMPRESSOR  
 - TURBINE HOUSING  
 - COMPRESSOR INLET AND SCROLL  
 - GEARBOX

## OPTIONAL FEATURES:

- ELECTRONIC LOGIC PACKAGE (MATED TO ACCEPT STANDARD MALFUNCTION INDICATOR AND START/OPERATION/SPEED CONTROL FUNCTIONS)
- GRAVITY FEED FUEL TANK
- 50/60 HZ, 30 KW GENERATOR WITH REGULATOR AND BATTERY CHARGER
- OUTPUT SPEEDS: 1500, 1800, 6000, 8000, 12,000 RPM
- OUTPUT PAD - AND 20006-10 OR AND 20002-5
- OUTPUT SHAFT



INDUSTRIAL ENGINES AND PRODUCTS, THE GARRETT CORP.  
 402 SOUTH 36TH ST., PHOENIX, ARIZONA 85010

# GTP36-51

## PRELIMINARY PERFORMANCE:

- PERFORMANCE SHOWN IS FOR SEA LEVEL OPERATION WITH NO INSTALLATION LOSSES
- ALTITUDE PERFORMANCE MAY BE ESTIMATED BY REDUCING HORSEPOWER SHOWN ON CURVE BY 3% FOR EVERY 1000 FT. GAIN IN ALTITUDE TO 10,000 FT.

### NOTES:

1. FUEL LOWER HEATING VALUE EQUALS 18,400 BTU/LB
2. ENGINE INLET TOTAL PRESSURE EQUALS STATIC PRESSURE AT ENGINE EXHAUST EQUALS AMBIENT PRESSURE
3. OUTPUT SHAFT SPEED EQUALS 3600 RPM
4. DELTA EQUALS ENGINE INLET TOTAL PRESSURE, IN. HG ABS, DIVIDED BY 29.92

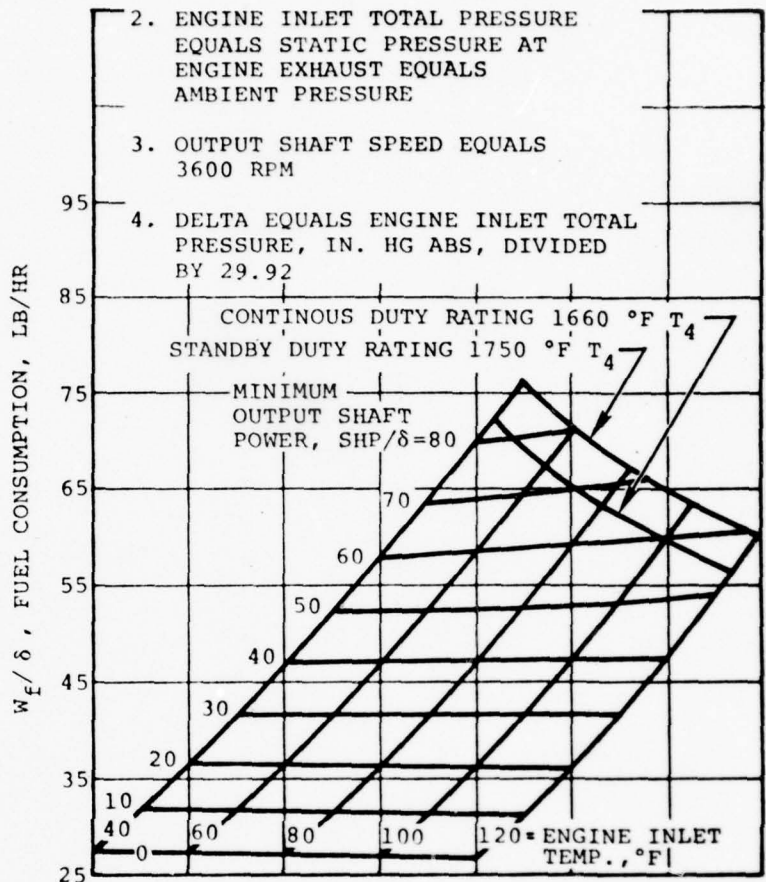

## CUSTOMER INSTALLATION CONSIDERATIONS

### FUEL REQUIREMENTS:

SUPPLY PRESSURE - LIQUID -  
TEMPERATURE -

GRAVITY TO 20 PSIG  
-65° TO +140°F

### ELECTRICAL REQUIREMENTS:

STARTING -

24 V CONSISTING OF 2 SERIES 2 HN BATTERIES  
OR EQUIVALENT - 45 AMP-HR SUPPLY

OPERATION -

18-30V D.C.

### OPERATING ENVIRONMENTS:

TEMPERATURE - ENGINE INLET AIR -  
ALTITUDE -

-65°F TO +120°F  
SEA LEVEL TO 10,000 FT (30 TO 20 IN HG)

### NOMINAL EXHAUST - GAS CHARACTERISTICS:

FLOW -  
TEMPERATURE -

0.92 LB/SEC (721 CFM)  
1200°F

### LUBRICATION REQUIREMENTS:

CAPACITY -

5 QUARTS, HEAT EXCHANGER SIZED FOR 120 BTU/MIN @ 2.5 GPM

# SOLAR

## Model T-20G-1 Gemini 10 kW Auxiliary Power Unit (APU)

### Performance Data

#### Fuels

MIL-J-5624, JP-4 and -5

MIL-F-16884 VV-F-800

MIL-G-3056, AVGAS

#### Oil

MIL-L-2104, MIL-L-7808

MIL-L-10295, MIL-L-23699

#### Output Pads

One 12,000 rpm

#### Rotor Speed

93,500 rpm

#### Rating at 59°F Sea Level [14.7 psia]

Zero Bleed 28 hp

Zero shp 20 lb/min bleed, 3.2:1 pressure ratio

#### Maximum Continuous Temperature

1300°F EGT

#### Weight

68.6 lb APU includes generator and starter

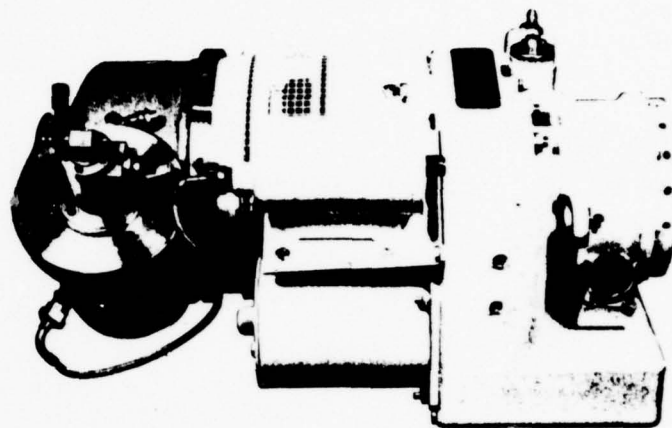

#### Maximum Fuel Consumption [Full Load, Continuous Duty]

27.5 (pph)

#### TBO

2000 hrs

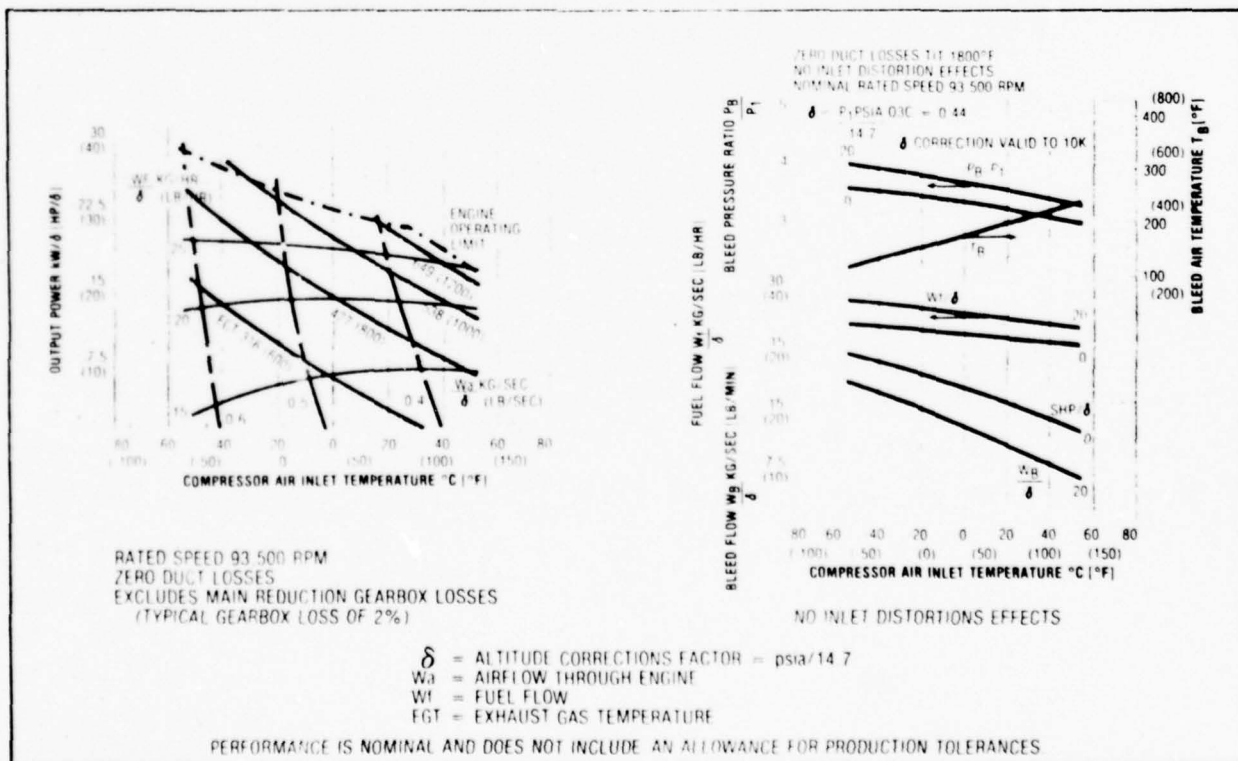

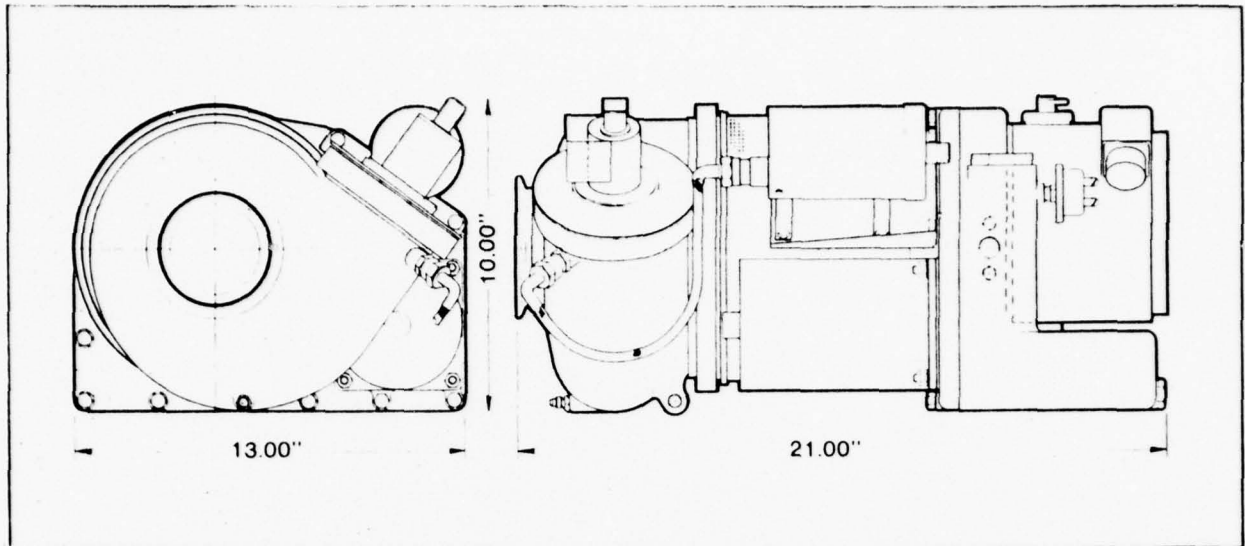

## Standard Features

- Integral Oil System
- Acceleration Control
- Automatic Start - Solid State Speed Sequencing
- Fully Automatic Control System
- Single-Stage Radial Compressor
- Single-Stage Radial-Inflow Turbine
- Cold End Drive
- Can Combustor with Motor Cup Atomizer
- Starts within 30 Seconds from -65°F to 130°F
- Operating Attitude: ( $\pm 30^\circ$  Pitch,  $\pm 30^\circ$  Roll)
- Overspeed Protection
- Overtemperature Protection
- Low Oil Pressure Protection

## Standard Accessories

- Oil Pump
- Oil Filter
- Fuel Filter
- Ignition System
- Fuel Control
- Oil Pressure Regulator
- EGT Thermocouple
- Overspeed Switch
- Oil Pressure Switch
- Overtemperature Switch
- Magnetic Speed Pickup
- Solid State Speed Sequencing and Temperature Control Unit
- Electric Starter

For more information, write:  
Solar Turbines International,  
Department 790, Radial  
Engine Division

T20G-1/1178

# SOLAR TURBINES INTERNATIONAL

An Operating Group of International Harvester  
2200 Pacific Highway, P.O. Box 80966, San Diego, California 92138

The words *Solar* and *Gemini* appearing herein are trademarks registered by International Harvester Company in the U.S. Patent Office

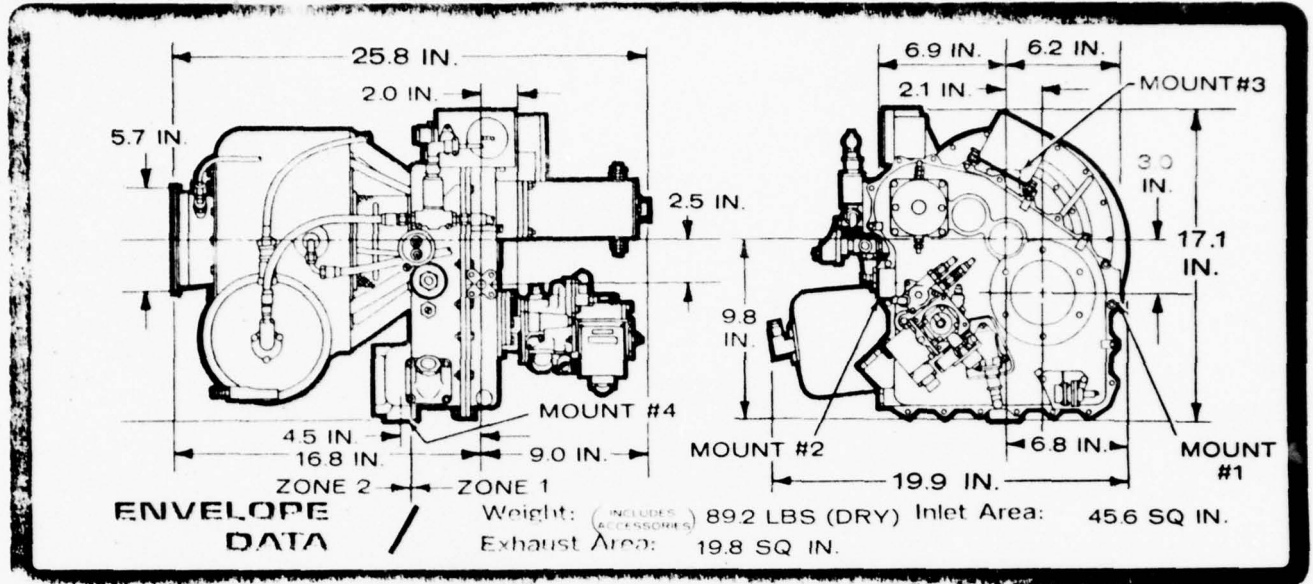

### PERFORMANCE DATA AND LEADING PARTICULARS:

**FUELS:** MIL-G-3056 (TYPE I), MIL-G-5572, MIL-J-5624 (JP-4&JP-5), VV-K-211, AND VV-F-800 (DF-A, DF-1, & DF-2)  
**OILS:** MIL-L-7808D

**OUTPUT PAD(S):** AND20002, TYPE XII-A  
**DIRECTION OF ROTATION:** 8,000 RPM CW (FACING PAD)  
**RATED EGT:** 1300 F  
**ROTOR SPEED:** 52,870 RPM  
**RATING:** (FOR INDICATED APPLICATION)  
**AMBIENT COND:** 59 F SEA LEVEL  
**BLD. AIR FLOW:** NONE  
**TEMP:** N/A **PRESS.:** N/A  
**PRESS. RATIO:** N/A **SHAFT HP:** 32.3  
**COMBINATION LOAD:** NONE

**SPECIFICATION DATA:**  
 INSTALLATION DRWG: 380452-1  
 MODEL SPEC.: SC-5665  
 BASIC SPEC: MIL-P-8686 & MIL-G-38259  
 APPLICATION: EMU12/E GENERATOR SET

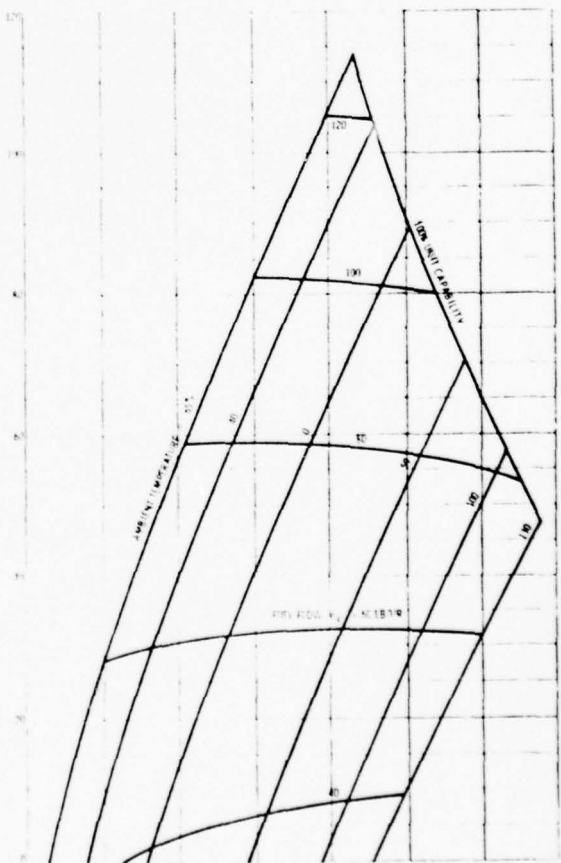

AIRESEARCH MANUFACTURING COMPANY OF ARIZONA, 402 SOUTH 36TH ST., PHOENIX, ARIZONA

MS 1401 2



# SOLAR

## MEP-412A Turbine Generator Set

Solar Turbines International is developing the new general purpose 10 KW 60 Hz turbine generator set for the United States Army Mobility Equipment Research and Development Center, Fort Belvoir, Virginia.

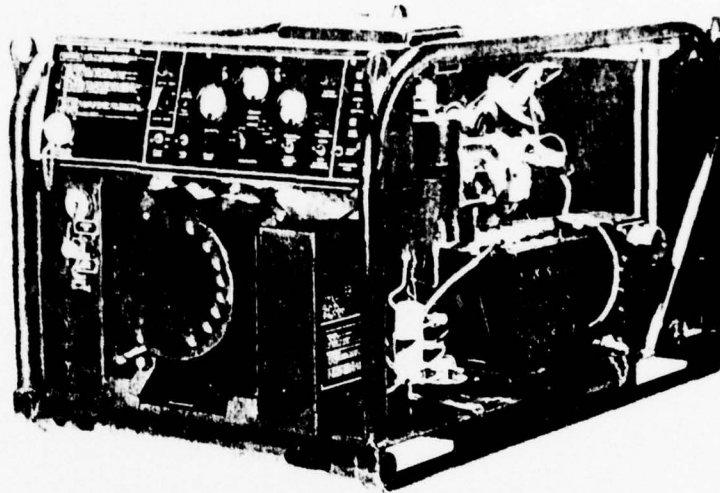

### General Characteristics

#### Model

MEP-412A

#### Classification

Tactical Utility

#### Electrical Output Rating

10 KW 60 Hz Sea Level 125°F  
10 KW 60 Hz 5000 Feet 107°F  
10 KW 60 Hz 8000 Feet 95°F

#### Output Connection

120 208 volts, three phase, four wire  
120 240 volts, single phase, three wire  
120 volts, single phase, two wire

#### Operating Speed

93,500 RPM (3600 RPM Generator Speed)

#### Weight

460 pounds

#### Size

45 inches long, 29 inches wide, 26 inches high

#### Fuel Consumption

3.0 gallons/hour

#### Fuel Types

JP-4, JP-5, Marine Diesel, Diesel DF-1, DF-2,  
Gasoline

#### Control Panel

Voltmeter, Percent Load Meter,  
Frequency Meter, Battery Charging  
Indicator, Hourmeter, Fault Indicator  
Lights, Voltage-Frequency Adjust,  
Output Breaker Switch, Start-Stop Switch

**This model is equipped for all-weather operation.**

*For more information write Solar Division of International Harvester, Dept. 605, San Diego, CA 92138, U.S.A.*



**SOLAR TURBINES INTERNATIONAL**  
An Operating Group of International Harvester

T25D/1077

# SOLAR TURBINES INTERNATIONAL

An International Development Group, 2000 Peachtree Highway, P.O. Box 80966, Atlanta, Georgia 30366

## 10 KW 60 HZ GAS TURBINE GENERATOR SET

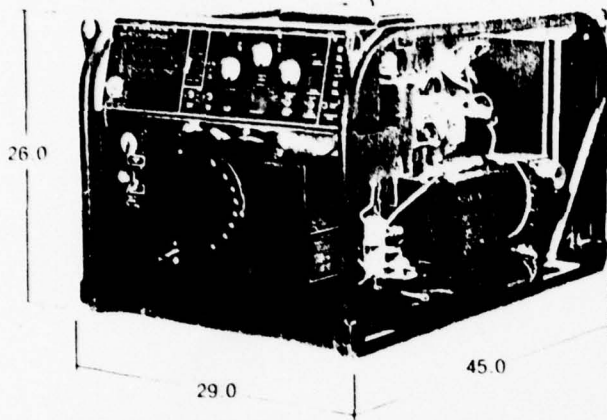

### CONTROL PANEL

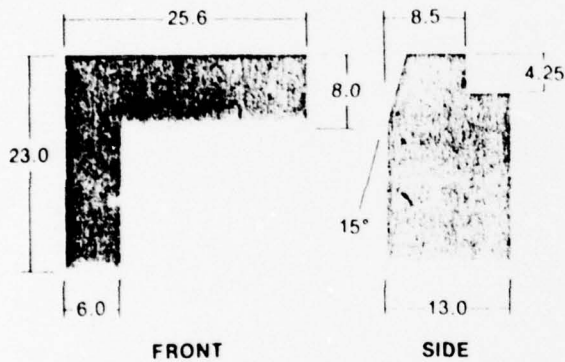

### ENGINE GENERATOR

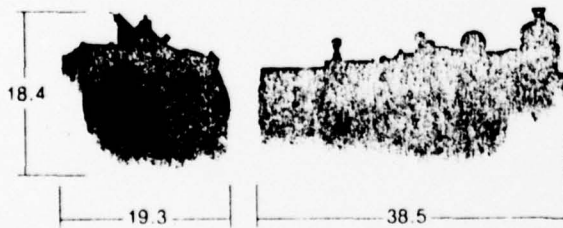

	WEIGHTS
• ENGINE GEARBOX GENERATOR .....	289.5
• CONTROL/DIST ASSY .....	38.5
• FRAME/BATTERY ACCESS ASSY .....	142.0
<b>TOTAL</b>	<b>450.0</b>

## 10 KW 400 HZ OR 28V D.C. TURBINE-ALTERNATOR SET

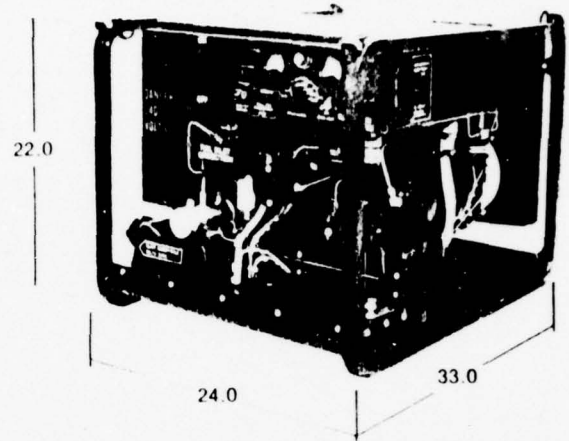

### POWER CONDITIONING UNIT

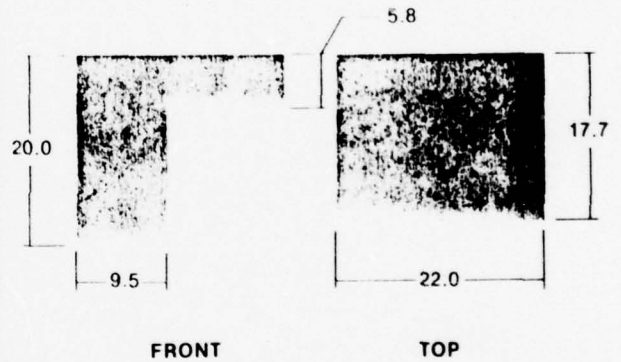

### ENGINE GENERATOR

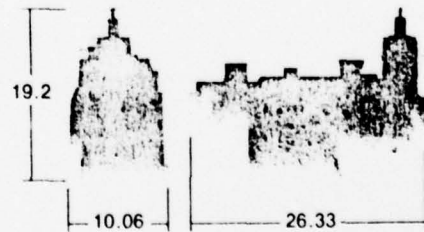

	WEIGHTS
• ENGINE GENERATOR .....	125.0
• POWER CONDITIONING UNIT .....	125.0
• FRAME .....	85.0
<b>TOTAL</b>	<b>335.0</b>

# LISTER

## ST2

### Air Cooled Diesel 9.4—23.4 bhp

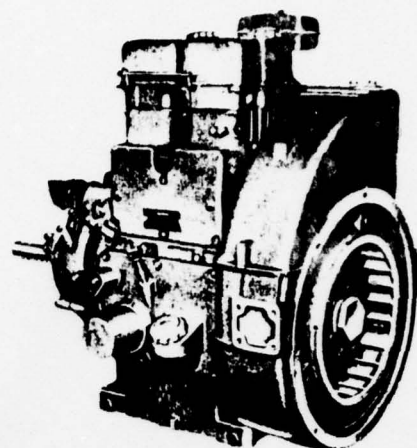

#### Specification

##### Cooling

By flywheel mounted fan.

##### Lubrication

A plunger pump supplies oil under pressure through a full flow filter.

##### Governing

To BS 649:1958

Class A2 for constant speed engines at 1500 and 1800 rev/min only.

Class B for variable speed engines.

##### Starting

By hand from the camshaft is standard.

Engines may be started at the flywheel end using increasing gear. Electric starting also available.

##### Power take-off

Full power at the flywheel end (crankshaft speed) and from the camshaft extension (half crankshaft speed)

##### Rotation

Either rotation available.

##### Standard Equipment

Fuel Filter Lubricating oil filter  
Lifting Eye Air Cleaner Starting handle Operators handbook and Parts List.

For detailed information about Standard 'Build' configurations see latest price list.

Please consult R. A. Lister for advice on applications for speeds above 2600 rev/min. Special consideration must be given to the effects of increased noise and vibration at these higher speeds.

#### Performance

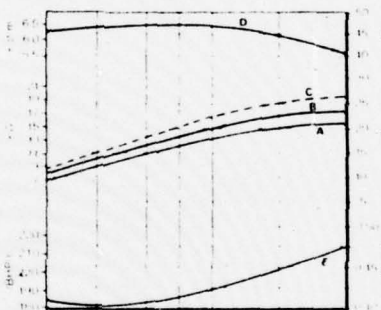

A — Continuous b.h.p. & DIN 6270 'A'

B — Intermittent b.h.p. & DIN 6270 'B'

C — Maximum gross b.h.p.

D — Torque at intermittent rating and DIN 6270 'B'

E — Fuel consumption at full load—these figures apply to fully run in, non derated, bare engines without power absorbing optional accessories, transmissions, gearboxes etc.

Derating for temperatures above 30 C (85 F) and altitudes above 150m (500 ft.) and humidity in accordance with BS 649/1958.

##### Rating BS 649/1958 (and Din 6270)

This is the bhp which the engine is capable of delivering continuously at a stated crankshaft speed in accordance with the conditions specified in BS 649/1958 (Din 'A'). The engine shall be capable of satisfactorily providing an output 10% in excess of the BS continuous rating at the same speed for one hour in any period of twelve hours consecutive running (Din 'B') unless driving centrifugal water pumps, fans and other similar equipment when overload is not permitted.

Note that 10% overload and Din 'B' ratings apply only to a fully run in engine. This is normally attained after a period of approximately 50 hours running, but if specially negotiated, engines can be supplied delivering these outputs ex works.

#### Technical Data

Rev/min	BS649 continuous b.h.p.	Rating kW
3000	21.0	15.7
2600	20.0	14.9
2000	16.2	12.1
1800	14.6	10.9
1500	12.0	8.9
1200	9.4	7.0

Rev/min	Din 6270 B Rating CV/PS	Rating kW
3000	23.4	17.2
2600	22.3	16.4
2000	18.1	13.3
1800	16.3	12.0
1500	13.4	10.8
1200	10.5	7.7

  

Torque at 10% overload at 1800 rev/min	lb ft	Rating kW
	46.85	6.48
	kgf m	6.48

Number of cylinders	2
Bore x Stroke	in 3.75 x 3.5 mm 92.25 x 88.9
Swept volume	in <sup>3</sup> 77.3 litre 1.27
bmpc at 1800 rev/min	lb/in <sup>2</sup> 83.1 bar 5.73
Cyclic irregularity with standard flywheel	1800 rev/min 1/76 1500 rev/min 1/53
Weight of bare engine	lb 375* kg 170*

\*Add 55 lb (25 kg) for cast iron fan shroud.

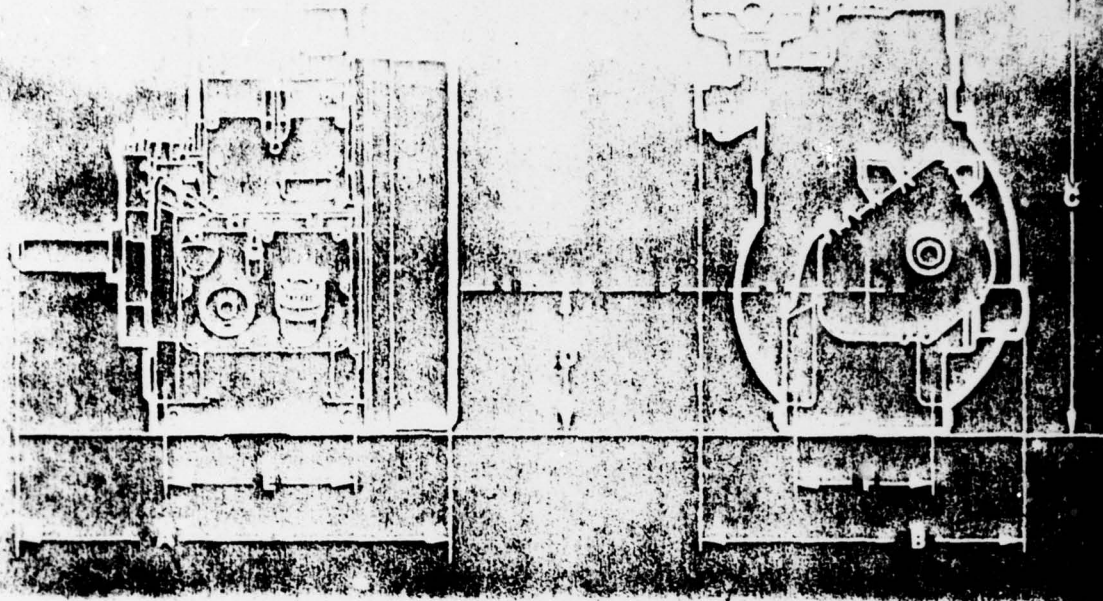

### Principal Dimensions

A 27.2" (690mm)	D 8.5" (216mm)
B 20.7" (525mm)	E 12.0" (305mm)
C 28.3" (720mm)	F 9.0" (228mm)

### OPTIONAL ACCESSORIES

- CODE A Air Cleaners**  
Heavy duty dry type  
Medium duty dry type
- CODE B Flywheel End Drives**  
Shaft extensions  
Half couplings  
Pulleys  
Clutch  
Adaptor for automotive clutch
- CODE C Close Coupling Adaptors**  
SAE 4, 5 & 6
- CODE D Air Duct Adaptor**
- CODE E Starting Equipment**  
Geared hand start  
12v. electric start with loose panel  
Battery
- CODE F Fuel Supply Equipment**  
Engine mounted tank  
Wall mounting tanks  
Fuel lift pump  
Fuel pipes
- CODE G Guards** (see note \* below)

### CODE H Hydraulic Pump Adaptors

Flywheel end  
Gear end

### CODE J Protection Devices and Solenoids

Air temperature and oil pressure switches  
Solenoids for fuel control and decompressors

### CODE K Controls

Variable speed lever and cable or rod  
2 speed control  
Remote or extended stop control

### CODE L Lubrication Equipment

Remote Filter adaptor  
Long running equipment (dry sump)

### CODE N Exhaust Equipment

Lister silencer  
Heavy duty silencer  
Flexible exhaust pipe  
Spark arrester

### CODE P Gauges

Ammeter  
Lub. oil pressure gauge  
Lub. oil pressure gauge combined with air temperature gauge  
Hour meter (vibratory type)

### CODE Q Mountings

Holding down bolts

### CODE R Recommended Spares

2500, 5000, 7500 and 12500 hour kits

### CODE S Sundries

Primer or Lister green paint finish  
Operators handbooks and Parts Lists  
Instruction plate loose  
Tool kit

For full details of our wide range of accessories please refer to latest price list.

### SHIPPING SPECIFICATIONS

(approximate)

Basic nett weight*	375lb	170kg
Basic gross weight*	470lb	210kg
Volume	16.2ft <sup>3</sup>	0.47m <sup>3</sup>

The information given in this catalogue is intended for the assistance of users and is based upon results obtained from tests carried out at the place of manufacture. The Company does not guarantee that the same results will be obtained elsewhere under different conditions. Prices and specifications are subject to amendment without notice and all information given is given subject to the Company's current Conditions of Tender and Sale.



HAWKER SIDDELEY

**LISTER DIESELS**

A-21

R A LISTER & CO LTD DURSLEY GLOUCESTERSHIRE GL11 4HS  
TEL DURSLEY 0453 4141 TELEX 43261 CABLES MACHINERY DURSLEY

# LISTER

## HR3



### Specification

#### Cooling

By flywheel mounted fan.

#### Lubrication

A rotary pump, below oil level supplies oil under pressure through a full flow filter.

#### Governing

To BS 649:1958

Class A for constant speed engines  
Class B for variable speed engines.

#### Starting

Starting by hand is standard, at either end of engine. Electric, hydraulic or air starting available.

#### Power take-off

At either end of the crankshaft—full power only from the flywheel end for belt drives.

Power may be taken from the gear end for approved applications.

#### Rotation

Anti-clockwise looking at the flywheel. Clockwise rotation available.

#### Standard Equipment

Exhaust silencer Fuel filter  
Full flow lubricating oil filter  
Lifting eye Oil bath air cleaner  
Starting handle  
Instruction books and parts list  
Tool kit.

#### Noise

Where quiet installations are required, contact our Applications Department for advice.

### Performance

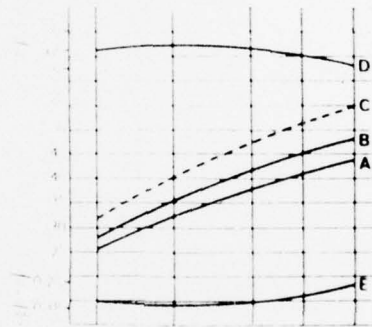

A — Continuous b.h.p.  
B — Intermittent b.h.p. & DIN 6270 'B'  
C — Maximum gross b.h.p.  
D — Torque 1 hr. rating & DIN 6270 'B' rating  
E — Fuel consumption at full load—these figures apply to fully run in, non derated, bare engines without power absorbing optional accessories, transmissions, gearboxes, etc.

Derating for temperatures above 30°C (85°F) and altitudes above 150 m (500 ft) in accordance with BS 649:1958

#### RATING

##### B.S. 649 : 1958 (and Din 6270)

This is the b.h.p. which the engine is capable of delivering continuously at a stated crankshaft speed in accordance with the conditions specified in B.S. 649:1958 (Din 'A'). The engine shall be capable of satisfactorily providing an output 10% in excess of the B.S. continuous rating at the same speed for one hour in any period of twelve hours consecutive running (Din 'B') unless driving centrifugal water pumps, fans and other similar equipment when overload is not permitted.

Note that 10% overload and Din 'B' ratings apply only to fully run-in engine. This is normally attained after a period of approximately 50 hours running, but if specially negotiated, engines can be supplied delivering these outputs ex works.

### Technical Data

BS 649:1958 rev/min rating	bhp
2200	44.25
2000	41.25
1800	37.5
1500	32.25
1200	25.5

Din 'B' rating rev/min	PS
2200	49.3
2000	46.0
1800	41.8

Max gross bhp at 2200 rev/min 55.0

Torque at 10% overload, at 1500 rev/min.	lb/ft	kg/m
	124.2	17.2

Number of cylinders 3

Bore x stroke	in	mm
	4.25 x 4.5	107.95 x 114.3

Swept volume	in <sup>3</sup>	cm <sup>3</sup>
	191.5	31.35

bmp at 1500 rev/min	lb/in <sup>2</sup>	bar
	88.9	6.12

Cyclic irregularity with standard flywheel at

rev/min	1/299	1/201
1800 rev/min		
1500 rev/min		

Weight of bare engine	lb	kg
	820*	372*

\*Add 80lb (36kg) for cast iron fan shroud

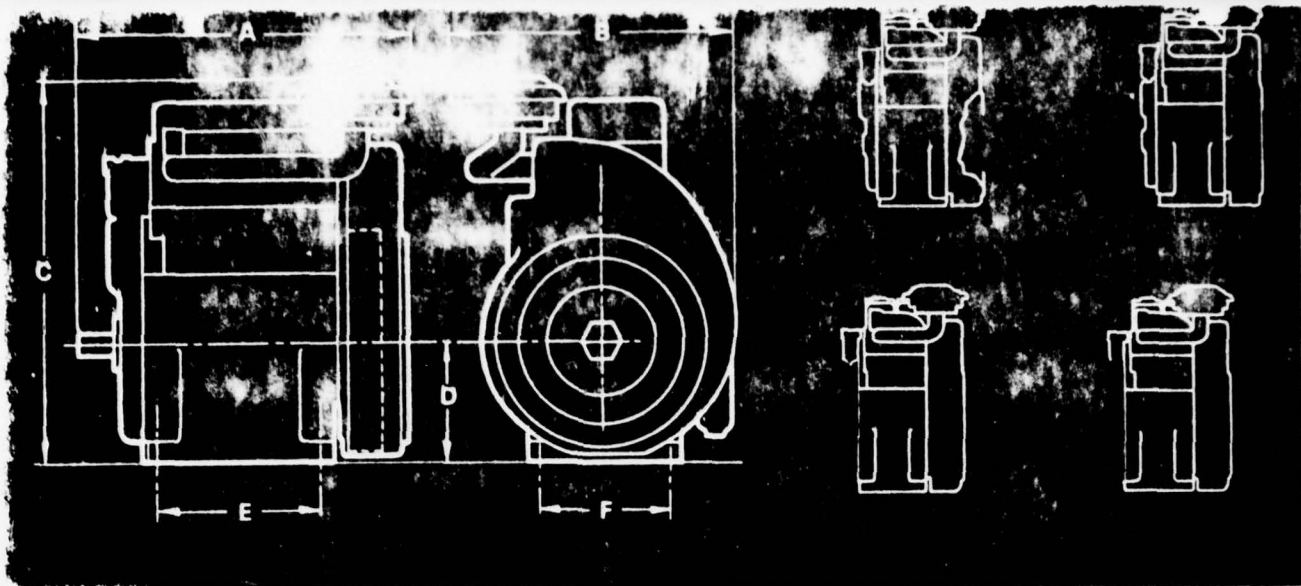

### Principal Dimensions

A	30" (762mm)	C	35.8" (909mm)	E	15.75 (400mm)
B	26" (660mm)	D	11" (279mm)	F	11.625" (295mm)

### Optional Extras

- Adaptor for
  - a. Flywheel housing SAE 1,2,3,4,5
  - b. Cooling air outlet duct for confined space installations.
- Air cleaner (a) dry type medium duty (b) dry type heavy duty (c) 3 stage oil bath medium duty
- Air temperature gauge.
- Battery—dry charged.
- Clutch
- Couplings—flexible half, or flexible whole.
- Decompressor, coupled.
- Exhaust silencer, extra duty types.
- Exhaust pipe, flexible.
- Flywheels, various, to suit application.
- Flywheel housing, cast iron, for close coupling SAE1.
- Fuel lift pump.
- Fuel tank—Wall mounting, 7 gal (32 litre).  
Engine mounted—4.5 gal (20 litre) or 9 gal (40 litre).
- Gears—2:1 Reduction.
- Guards—
  - a. Rotating fan screen for use in dusty conditions.
  - b. Starting shaft (gear case end).
  - c. Flywheel.
- Hydraulic pump adaptors—suitable for most manufacturers pumps and for pumps to SAE standards.

- Lubricating oil cooler (tropical conditions).
- Lubricating oil pressure gauge.
- Lubricating oil dipstick various positions.
- Protection devices—
  - a. High air temperature switch.
  - b. Low oil pressure switch.
  - c. Overspeed switch.
  - d. 12/24v Fuel control solenoid.
  - e. Mechanical protection for high air temperature and low oil pressure.
- Pulleys.
- Running hour recorder—mechanical or electrical.
- Shaft extension, flywheel end—
  - a. 2" dia. for power take-off.
  - b. 1.5" dia. for starting handle.
- Shaft extension, gear case end—
  - a. For full power direct coupling or very light belt or chain drives up to 20 hp at 2000 rev/min.
  - b. With extra bearing, for all heavy duty drives.
- NOTE: the use of either of these extensions necessitates fitting of 1.5" dia. extension (b) above to the flywheel to take starting handle.
- Speed control—variable, for rod or cable operation.

### Starting —

- a. 12v electric, with d.c. generator, less battery, (instruments supplied loose).
- b. 24v electric, with alternator, less battery, (instruments supplied loose).
- c. Type A with dynamo at gearcase end.
- d. Type B with dynamo at flywheel end.
- e. Cubicle for electric starting equipment (supplied loose).
- f. American starter and alternator fittings, including gear ring, alternator brackets and belt.

Tachometer and running hour recorder.

### Shipping Specification (approximate)

Basic nett weights*	820lb	372kg*
Basic gross weight*	1170lb	526kg
Volume	37ft <sup>3</sup>	1.05m <sup>3</sup>

\*Add 80lb (36kg) when cast iron fan shroud is fitted.

The information given in this catalogue is intended for the assistance of users and is based upon results obtained from tests carried out at the place of manufacture. The Company does not guarantee that the same results will be obtained elsewhere under different conditions. Prices and specifications are subject to amendment without notice and all information given is given subject to the Company's current Conditions of Tender and Sale.

 HAWKER SIDDELEY

Printed in England © 1976 Publication HR3 10M 3/76

# LISTER DIESELS

A-23

LISTER & CO. LTD. DURSLEY, GLOUCESTERSHIRE GLETT. DORS. TEL. DURSLEY 3141 TELEX: 43261. CARLES MACHINERY, DURSLEY.

APPENDIX 4  
DESCRIPTION OF SELECTED ELASTOMERIC CLASSES

**Silicone (MQ, PMQ, VMQ, PVMQ, FC, FE, GE)** Silicone rubber comprises a versatile family of semi-organic synthetics that look and feel like organic rubber, yet have a completely different type of structure from other rubbers. The backbone of the rubber is not a chain of carbon atoms but an arrangement of silicone and oxygen atoms. This structure gives a very flexible chain with weak interchain forces, which provides a remarkably small change in dynamic characteristics over a wide range of temperature. Silicone rubbers have no molecular orientation or crystallization on stretching and must be strengthened by reinforcing materials.

*Silicone rubbers are at the high end of the cost range for rubbers, but they can be made to withstand temperatures as high as 600° F without deterioration. At the other end of the scale, silicones retain useful flexibility at -150° F. No plasticizers are needed that might cause some sacrifice in properties.*

While the strength of silicone rubbers is lower than that of other rubbers, they have outstanding fatigue and flex resistance. They do not require high tensile and tear strength to be suitable for dynamic applications. Fall-off in tensile properties with extended exposure to high temperatures is less than for other rubbers. Resistance to chemical deterioration, oils, oxygen, and ozone is also retained under these conditions. Chemical inertness makes these materials of special interest for surgical and food-processing equipment.

**Polybutadiene (BR, AA)** This general-purpose, crude-oil-based rubber is even more resilient than natural rubber. It was the material that made the solid golf ball possible. It is also superior to natural rubber in low-temperature flexibility and exhibits less dynamic heat buildup. It does, however, lack the toughness, durability, and cut-growth resistance of NR. It can be blended with natural rubber or SBR to improve their low-temperature flexibility. Silicones have superior low-temperature flexibility, but this is achieved at a much higher price and at a sacrifice in other properties such as tensile strength, tear resistance, and general durability.

Large-volume polybutadiene use is in blends with other polymers to enhance their resilience and reduce heat buildup. It is also used in products requiring high resiliency over a broad temperature range such as industrial tires and vibration mounts.

**Fluorosilicone (FVMQ, FK)** This type of silicone provides most of the useful qualities of the regular silicones plus improved resistance to many fluids. Exceptions are ketones and phosphate esters; however, FVMQ rubbers can be blended with conventional dimethyl silicones which have good resistance to these fluids at temperatures to 300° F. The FVMQ rubbers are most useful where the best in low-temperature flexibility is required in addition to fluid resistance, although resistance to fluids (especially those containing aromatics) is poorer than that of the FKM-type fluorocarbon rubbers. Although improvements have been made in the general strength of the fluorosilicone rubbers, more durability under both static and dynamic stress would greatly improve their application potential.

Fluorosilicone rubbers have good dielectric properties, low compression set, and excellent resistance to ozone and weathering. They are expensive and definitely special purpose. Typical applications include seals, tank linings, diaphragms, O-rings, and protective boots in electrical equipment.

**Ethylene propylene (EPR, EPDM; AA, BA, CA):** Like the butyls, the EP rubbers are of two types. One is a fully saturated (chemically inert) copolymer of ethylene and propylene (EPR); the other (EPDM) is the same as this plus a third polymer building block (diene monomer) attached to the side of the chain. EPDM is chemically reactive and is capable of sulfur vulcanization. The copolymer must be cured with peroxide.

These materials were originally touted as being the economic ultimate in rubber materials—one that would put natural rubber out of business. This economic superiority was never achieved, however, because of the increasing yield per acre from natural-rubber plantations.

Physical properties of EPR and EPDM are not as good as those obtainable with NR. However, property-retention is better than NR on exposure to heat, oxidation, or ozone. Bonding is somewhat more difficult, especially with EPR.

Typical applications are automotive hose, body mounts and pads, O-rings, conveyor belting, wire and cable cover, window channeling, and other products requiring excellent weathering resistance.

**Natural rubber (D 1419; NR; D 2000; AA):** The commercial base for natural rubber is latex, a milk-like serum, generated by the tropical tree, *Hevea Brasiliensis*. The latex is collected in much the same fashion as maple sap. However, latex should not be confused with the sap of the tree. Latex is secreted in the inner bark of the tree, and a tree can be severely harmed if a tapping cut is deep enough to draw sap as well as latex. Naturally occurring latex is a dispersion of rubber in an aqueous serum containing various inorganic and organic substances. The rubber precipitated out of this solution can be characterized as a coherent elastic solid.

It is against natural rubber that all other rubbers should be measured. For centuries it was the only rubber available, and it was used extensively even before the discovery of vulcanization in 1839.

Synthetic rubbers have been developed either by accident or as the result of pressures of political upheaval and consequent unavailability of the natural product. However, no synthetic material has yet equalled the overall engineering characteristics and consequent wide latitude of application available with NR.

As with other rubbers, many grades and types of NR are available; these are produced by varying impurity levels, collection methods, and processing techniques. Natural rubber is generally considered to be the best of the general-purpose rubbers—those that embody properties and characteristics suitable for broad engineering applications. Superior compounds can be evolved over a wider stiffness range with natural rubber than with any other material and at a competitive price which will, in all probability, become even more significant as the energy situation worsens.

Natural rubber is likely the best choice for most applications except those where an extreme performance or exposure requirement dictates the use of a special-purpose rubber, often at some sacrifice of other, less critical characteristics.

Natural rubber has a large deformability capacity. This, coupled with its ability to strain crystallize, gives it added strength

while deformed. Its high inherent resilience, which is responsible for a very low heat buildup in flexing, makes NR a prime candidate for shock and severe dynamic loads. Properties negatively affected by heat such as flex, abrasion resistance, cut resistance, and endurance generally can thus be much improved. NR has low compression set and stress relaxation; these characteristics favor its application in sealing devices where maintenance of sealing forces and the surface conformability of high-quality soft stocks are important. Further advantages are excellent green (uncured) strength, building tack, and general processing characteristics.

Natural rubber does have some shortcomings, as do the other general-purpose rubbers. There are rubbers, for example, that maintain initial properties at greater extremes of temperatures. The useful service temperature of natural rubber is generally considered to range from -65 to (in special cases) +250°F, which covers most applications. Other drawbacks of NR such as poor oil, oxidation, and ozone resistance can be minimized or virtually eliminated, either by proper design attention and/or by compounding. These degradative forces are essentially surface effects which can be tolerated by using thicker cross sections, shielding, or antioxidants and antiozonants.

Natural rubber often can be the first choice for many high-performance applications if it can be made to live in the service environment. It remains the best choice for tires, shock mounts and other energy absorbers, seals, isolators, couplings, bearings and other motion-accommodation devices, springs, and other dynamic applications.

**Epichlorohydrin (CO, ECO, CH)**  
Epichlorohydrin rubber is available as a homopolymer (CO) and a copolymer (ECO) of epichlorohydrin. Reinforced these rubbers have moderate tensile strength and elongation properties, plus an unusual combination of other characteristics. One of these is low heat buildup which makes them suitable for applications involving cyclic shock or vibration.

The homopolymer has outstanding resistance to ozone, good resistance to swelling by oils, intermediate heat resistance, extremely low permeability to gases, and excellent weathering properties. This rubber also has low resilience characteristics and low-temperature flexibility only to 5° F—characteristics that may not be desirable for some applications.

The copolymer is more resilient and has low-temperature flexibility to -40° F but it has poorer permeability characteristics. Oil resistance of both compounds is about the same.

Typical applications for these rubbers include bladders, diaphragms, vibration-control equipment, mounts, vibration dampers, seals, gaskets, fuel hose, rollers, and belting.

**Styrene butadiene (SBR AA, BA)**: This material emerged as a high-volume substitute for NR during World War II because of its suitability for use in tires. Despite the fact that the basic feedstock for SBR is crude oil, it has remained quite competitive in cost because of the extensive production capacity for SBR in the U. S.

SBR continues to be used in many of the applications where it earlier replaced NR, even though it does not have the overall versatility of natural rubber and the other general-purpose materials. For most applications, SBR must be reinforced (heavy stocks are stiffer) in order to have acceptable tensile strength, tear resistance, and general durability. SBR is significantly less resilient than NR, so it has higher heat buildup on flexing. Further, it does not have the processing and fabricating qualities of NR, lacking both green strength and building tack.

An important reason for the continued high volume use of SBR is that it did a creditable job in passenger car tires, having good abrasion resistance and general durability. Recently that picture has changed, however, because of the greater need for the green strength and building tack of natural rubber in radial tires and for the better low-temperature flexibility of natural rubber for snow tires (with studs being on the way out). High-performance tires, such as for trucks and aircraft, have always been made from natural rubber if it was available.

Specific product use of SBR rubbers is somewhat the same as for natural rubber except for products needing high-quality soft stocks, and for other applications that are more demanding.

**Urethane (AU, EU, BU)**: These rubbers, combinations of polyesters or polyethers and diisocyanates, are unusual in that physical properties do not depend on compounding materials. Urethanes crosslink and undergo chain extension to produce a wide variety of compounds. They are available as castable or liquid materials and as solids or malleable gums.

Urethane polymers have excellent tensile strength, load-bearing capacity, and elongation potential, accompanied by high hardness and outstanding abrasion resistance. Other properties include high tear strength, either high or low coefficient of friction, and good elasticity and resilience, even in very hard stocks.

Typical applications include seals, bumpers, metal-forming dies, valve seats, liners, coupling elements, rollers, wheels, and conveyor belts, especially where abrasive conditions are present.

**Butyl (IIR, CIIR, AA, BA):** The two types of rubber in this category are both based on crude oil. The first is polyisobutylene with an occasional isoprene unit inserted in the polymer chain to enhance vulcanization characteristics. The second is the same, except that chlorine is added (approximately 1.2% by weight) resulting in greater vulcanization flexibility and enhanced cure compatibility with general-purpose rubbers.

Butyl rubbers have outstanding impermeability to gases and excellent oxidation and ozone resistance. The chemical inertness is further retorted in lack of molecular-weight breakdown during processing, thus permitting the use of hot-mixing techniques for better polymer/filler interaction.

Flex, tear, and abrasion resistance approach those of natural rubber, and moderate-strength (2,000 psi) unreinforced compounds can be made at a competitive cost. They do lack the toughness and durability of some of the general-purpose rubber, however.

The attribute responsible for the high-volume use of butyl rubber in automotive inner tubes and tubeless tire innerliners is its excellent impermeability to air. Here, they occupy a dominant position. The butyls are also used in belting, steam hose, curing bladders, O-rings, shock and vibration products, structural caulks and sealants, water-barrier applications, roof coatings, and gas-metering diaphragms.

**Neoprene (CR, BC, BE):** Except for polybutadiene and polyisoprene, neoprene is perhaps the most rubberlike of all, particularly with regard to dynamic response. Neoprenes are a large family of rubbers that have a property profile approaching that of natural rubber, and with better resistance to oils, ozone, oxidation, and flame. They age better and do not soften on heat exposure, although high-temperature tensile strength may be lower than that of NR. These materials, like NR, can be used to make soft, high-strength compounds. A significant difference is that, in addition to neoprene being more costly than NR by the pound, the density of neoprene is about 25% higher than that of natural rubber. Neoprenes do not have the low-temperature flexibility of natural rubber, which detracts from their use in shock or impact applications.

General purpose neoprenes are used in hose, belting, wire and cable, footwear, coated fabrics, tires, mountings, bearing pads, and pump impellers.

**Polysulfide (PTR, AK, BK):** These polymers have outstanding resistance to oils, greases, and solvents, but they have an unpleasant odor, resilience is poor, and heat resistance is only fair. Abrasion resistance is about half that of natural rubber, and tensile strength ranges from 1,200 to 1,400 psi. However, these values are retained after extended immersion in oil.

Basic properties of polysulfide polymers are determined by the type of chain structure and the number of sulfur atoms in the polysulfide groups. Increased sulfur concentration improves solvent and oil resistance, and also reduces the permeability to gases. These materials are used in gasoline hose, printing rolls, and newspaper blankets. Other uses include caulking materials, adhesives, and binders.

### Typical properties of thermoplastic elastomers

ASTM test	Property	Copolyester	SB copolymer
PHYSICAL			
D792	Specific gravity	1.17-1.25	0.93-1.10
—	Specific volume (in <sup>3</sup> /lb)	—	37.4-27.5
D570	Water absorption, 24 hr. (% in thick.)	0.3	0.19-0.39
MECHANICAL			
D638	Tensile strength (psi)	5,900-6,400	600-2,300
D638	Elongation (%)	390-500	500-1,350
D638	Tensile modulus (10 <sup>3</sup> psi)	—	0.8-5.0
D785	Hardness, Shore	90A-7. D	40-95A
D790	Flexural strength (psi)	—	—
D790	Flexural modulus (10 <sup>3</sup> psi)	7-75	4-150
D256	Impact strength, Izod (ft-lb/in. of notch)	No break	No break

### Copolyesters

Copolyester thermoplastic elastomers are generally tougher over a broader temperature range than the urethanes. They are produced by DuPont (Hytrel) in four hardnesses ranging from 90 Shore A to 72 Shore D. These materials are suitable for injection molding, extrusion, rotational molding, and thermofforming. Powders are available for fluidized-bed coatings.

These elastoplastics, which are in the same price range as the urethanes, have a high modulus, good elongation and tear strength, and good resistance to flex fatigue at both low and high temperature. Brittle temperature is below -90° F. and stiffness increases only moderately at -40° F.

Resistance of the copolyesters to nonoxidizing acids, some aliphatic hydrocarbons, aromatic fuels, sour gases, alkaline solutions, hydraulic fluids, and oil is good to excellent. However, strong mineral acids and bases, chlorinated solvents, phenols, and cresols soften or swell these materials. Weathering resistance is low unless antioxidants or carbon blacks are compounded with the resin.

Applications of Hytrel elastomers include hydraulic hose, power-transmission belts and couplings, tracks for snow-mobiles, low-pressure tires, rolls, and wire and cable jacketing.

### Styrene copolymers

The styrenics are the lowest priced thermoplastic elastomers. They are block-copolymers, produced with hard polystyrene segments in a matrix of either polybutadiene or polyisoprene.

These block-copolymer elastomers are resilient materials available in several molding and extrusion grades ranging in hardness from 40 to 95 Shore A. Styrene copolymers are produced by Shell Chemical Co. (Kraton) and Phillips Petroleum Co. (Solprene).

Tensile strength of these materials is lower and elongation is higher than SBR or natural rubber, and weather resistance is about the same. Other resistance characteristics can be improved by the addition of resins such as polypropylene or ethylene-vinyl acetate. The styrenic elastoplastics resist water, alcohols, and dilute alkalies and acids. They are soluble in, or are swelled by, strong acids, chlorinated solvents, esters, and ketones. One type has a service temperature limit of 150° F.; another grade can be used to 300° F. Both have excellent low-temperature flexibility to -120° F.

Applications for the styrene-butadiene block copolymers include disposable medical products, food packaging, tubing, sheet, belting, mallet heads, and shoe soles. These materials are also used in sealants and pressure-sensitive adhesives.

REPORT DOCUMENTATION PAGE		READ INSTRUCTIONS BEFORE COMPLETING FORM
1. REPORT NUMBER DAAK-70-77-D-0024	2. GOVT ACCESSION NO.	3. RECIPIENT'S CATALOG NUMBER
4. TITLE (and Subtitle) SYSTEMS ANALYSIS OF ARCTIC FUEL DISPENSING EQUIPMENT		5. TYPE OF REPORT & PERIOD COVERED Final Report January 1, 1979 to June 30
		6. PERFORMING ORG. REPORT NUMBER 80260-18 ✓
AUTHOR(s) Donald B. Rosenfield, Edgar A. Gilbert III, John S. Howland		8. CONTRACT OR GRANT NUMBER(s) DAAK-70-77-D-0024
PERFORMING ORGANIZATION NAME AND ADDRESS Arthur D. Little, Inc. 20 Acorn Park Cambridge, Mass. 02140		10. PROGRAM ELEMENT, PROJECT, TASK AREA & WORK UNIT NUMBERS
11. CONTROLLING OFFICE NAME AND ADDRESS U.S. Army Mobility Equipment Research and Development Command, Procurement and Production Directorate, Fort Belvoir, Virginia		12. REPORT DATE June 30, 1979
14. MONITORING AGENCY NAME & ADDRESS (if different from Controlling Office) Same #11		13. NUMBER OF PAGES 129
		15. SECURITY CLASS. (of this report) Unclassified
		15a. DECLASSIFICATION/DOWNGRADING SCHEDULE N/A
16. DISTRIBUTION STATEMENT (of this Report) Distribution of this document is unlimited		
17. DISTRIBUTION STATEMENT (of the abstract entered in Block 20, if different from Report)		
18. SUPPLEMENTARY NOTES		
19. KEY WORDS (Continue on reverse side if necessary and identify by block number) Systems Analysis Cost-Benefit Arctic Elastomerics Fuel Supply <i>deg</i>		
20. ABSTRACT (Continue on reverse side if necessary and identify by block number) A systems analysis was performed to evaluate military fuel dispensing systems for arctic applications. The present systems, the Forward Area Refueling equipment (FARE) and Fuels System Supply Point (FSSP) encounter problems in the areas because engines fail to start and elastomerics become brittle at temperatures of -60°F. The systems analysis consisted of two phases of evaluating and scoring system attributes for numerous combinations of systems concepts and components. The systems with the highest evaluations were the		

SECURITY CLASSIFICATION OF THIS PAGE(When Data Entered)

basic designs with gas turbine drives, state-of-the-art elastomerics, and either state-of-the-art batteries or a compressed gas start. It was also concluded that additional development should be undertaken in the area of cold weather elastomerics.

SECURITY CLASSIFICATION OF THIS PAGE(When Data Entered)



Arthur D Little, Inc

CAMBRIDGE,  
MASSACHUSETTS

SAN FRANCISCO  
WASHINGTON

ATHENS

BRUSSELS

LONDON

MADRID

PARIS

RIO DE JANEIRO

SÃO PAULO

TOKYO

TORONTO

WIESBADEN