

AD-A072 029

MAN-ACOUSTICS AND NOISE INC SEATTLE WASH  
COMMERCIAL AIRCRAFT FLIGHT DECK NOISE CRITERIA.(U)  
JAN 79 J E MABRY, B M SULLIVAN, R A SHIELDS

F/G 20/1

DOT-FA77WAI-723

UNCLASSIFIED

MAN-1037

FAA/RD-79-66

NL

1 OF 1  
AD  
A072029

END  
DATE  
FILMED  
9-79  
DDC

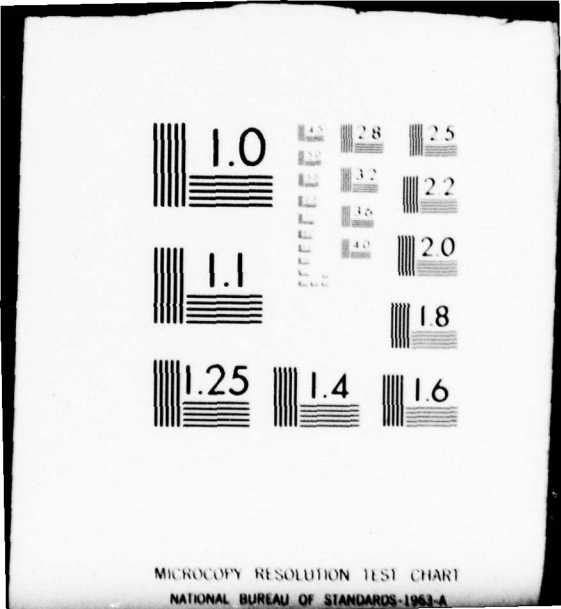

MICROCOPY RESOLUTION TEST CHART  
NATIONAL BUREAU OF STANDARDS-1963-A

812

AD A 072029

# COMMERCIAL AIRCRAFT FLIGHT DECK NOISE CRITERIA

# LEVEL <sup>II</sup>

J.E. Mabry  
B.M. Sullivan  
R.A. Shields



FINAL REPORT  
JANUARY 1979

DDC  
RECEIVED  
JUL 31 1979  
A

Document is available to the U.S. public through  
the National Technical Information Service,  
Springfield, Virginia 22161.

DDC FILE COPY

Prepared for

**U.S. DEPARTMENT OF TRANSPORTATION**  
**FEDERAL AVIATION ADMINISTRATION**  
**Systems Research & Development Service**  
**Washington, D.C. 20590**

79 07 30 103

**NOTICE**

**This document is disseminated under the sponsorship of the Department of Transportation in the interest of information exchange. The United States Government assumes no liability for its contents or use thereof.**

|   |  |   |  |
|---|--|---|--|
| 1. Report No.<br><b>18</b> <u>19</u><br>FAA-RD-79-66  | 2. Government Accession No.                          | 3. Recipient's Catalog No.<br><b>11</b>   |  |
| 4. Title and Subtitle<br><b>6</b> <u>COMMERCIAL AIRCRAFT FLIGHT DECK NOISE CRITERIA</u>   |  | 5. Report Date<br>January 1979  | 6. Performing Organization Code                                |
| 7. Author(s)<br><b>10</b> J. E. Mabry, B. M. Sullivan, and R. A. Shields  |  | 8. Performing Organization Report No.<br><b>14</b> MAN-1037   | 10. Work Unit No. (TRAIS)                                      |
| 9. Performing Organization Name and Address<br>MAN-Acoustics and Noise, Inc.<br>2105 North 45th Street<br>Seattle, WA 98103   |  | 11. Contract or Grant No.<br><b>15</b> DOT-FA77WAI-723  | 13. Type of Report and Period Covered<br><b>9</b> Final Report |
| 12. Sponsoring Agency Name and Address<br>Department of Transportation<br>Federal Aviation Administration<br>Systems Research & Development Service<br>Washington, D.C. 20590   |  | 14. Sponsoring Agency Code<br>ARD-550   |  |
| 15. Supplementary Notes   |  |   |  |
| <p>16. Abstract</p> <p>As a method for obtaining results that could contribute to the establishment of commercial jet aircraft flight deck noise criteria, fifty persons were exposed to simulations of various flight deck noise exposure conditions. Exposure levels investigated were 75, 80 and 85 dBA for periods of 1, 2, and 4 hours. Noise spectra representing both older narrow-body and newer technology wide-body jet aircraft were utilized. Response measures emphasized were temporary threshold shift (TTS) and speech intelligibility, but annoyance ratings to the exposure conditions were also obtained. Some of the results were:</p> <ul style="list-style-type: none"> <li>- No appreciable TTS was measured at 500, 1000, 2000, or 4000 Hz for any exposure period at 75 and 80 dBA levels.</li> <li>- Some TTS was measured at 85 dBA for a 4-hour exposure period but the extent of TTS was not serious or extensive.</li> <li>- Speech intelligibility performance was not degraded by exposure.</li> <li>- There was evidence that noise adaptation does occur over relatively short periods of exposure time.</li> <li>- The flight deck noise spectrum representing the newer technology wide-body aircraft is more desirable than that representing the older narrow-body aircraft.</li> <li>- Commonly used engineering calculation procedures such as dBA, PNdB and PSIL did not adequately reflect the human response differences.</li> </ul> |  |   |  |
| 17. Key Words<br>Flight deck noise criteria<br>Temporary threshold shift<br>Speech intelligibility<br>Adaptation to noise<br>Noise calculation procedures   |  | 18. Distribution Statement<br>Document is available to the public through the National Technical Information Service, Springfield, VA |  |
| 19. Security Classif. (of this report)<br>Unclassified  | 20. Security Classif. (of this page)<br>Unclassified | 21. No. of Pages<br>70  | 22. Price  |

408 220

JCB

# METRIC CONVERSION FACTORS

| Approximate Conversions to Metric Measures |                        | Approximate Conversions from Metric Measures |                        |
|--|------------------------|--|------------------------|
| Symbol                                     | When You Know          | Multiply by                                  | To Find                |
| <b>LENGTH</b>                              |                        |  |                        |
| in   | inches                 | 2.5  | centimeters            |
| ft   | feet                   | 30   | centimeters            |
| yd   | yards                  | 0.9  | meters                 |
| mi   | miles                  | 1.6  | kilometers             |
| <b>AREA</b>                                |                        |  |                        |
| sq in                                      | square inches          | 6.5  | square centimeters     |
| sq ft                                      | square feet            | 0.09   | square meters          |
| sq yd                                      | square yards           | 0.8  | square meters          |
| sq mi                                      | square miles           | 2.5  | square kilometers      |
| ac   | acres                  | 0.4  | hectares               |
| <b>MASS (weight)</b>                       |                        |  |                        |
| oz   | ounces                 | 28   | grams                  |
| lb   | pounds                 | 0.45   | kilograms              |
|  | short tons (2000 lb)   | 0.9  | tonnes                 |
| <b>VOLUME</b>                              |                        |  |                        |
| cup  | teaspoons              | 5  | milliliters            |
| fl oz                                      | tablespoons            | 15   | milliliters            |
| c  | fluid ounces           | 30   | milliliters            |
| pt   | cups                   | 0.24   | liters                 |
| qt   | pints                  | 0.47   | liters                 |
| gal  | quarts                 | 0.96   | liters                 |
| cu ft                                      | gallons                | 3.8  | liters                 |
| cu yd                                      | cubic feet             | 0.03   | cubic meters           |
|  | cubic yards            | 0.76   | cubic meters           |
| <b>TEMPERATURE (exact)</b>                 |                        |  |                        |
| °F   | Fahrenheit temperature | 5/9 (after subtracting 32)                   | Celsius temperature    |
| °C   | Celsius temperature    | 9/5 (then add 32)                            | Fahrenheit temperature |

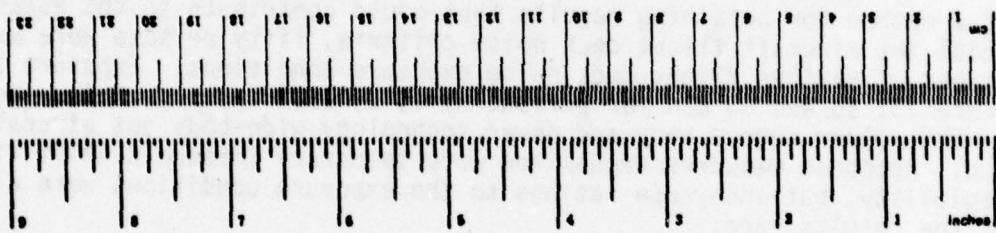

\* 1 in = 2.54 exactly. For other exact conversions and more data tables, see NBS Misc. Publ. 286, Units of Weight and Measure, Price \$2.25, SO Catalog No. C13.10/286.

### ACKNOWLEDGEMENTS

The measurement of noise levels on the flight decks of various commercial jet aircraft was made possible by Captains J. T. Fredrickson and R. L. Scott of Northwest Orient Airlines. During these measurement flights, a large pool of air-to-tower communications were also recorded and the realistic speech intelligibility test was derived from these communications. We want to thank Captains Fredrickson and Scott very much for their valued assistance. Man-Acoustics and Noise personnel who contributed significantly to this program were John Ott and Chris Mitchell.

We want to especially thank Thomas H. Higgins, Program Manager of the Federal Aviation Administration, Systems Research and Development Service for his technical leadership and many contributions to this study. His continued interest and assistance were of significant value in initiating, conducting, and completing the program successfully.

|                    |                                     |
|--------------------|-------------------------------------|
| Accession For      |                                     |
| NTIS Grant         | <input checked="" type="checkbox"/> |
| DOD TAB            | <input type="checkbox"/>            |
| Unannounced        | <input type="checkbox"/>            |
| Justification      |                                     |
| By _____           |                                     |
| Distribution/      |                                     |
| Availability Codes |                                     |
| Dist.              | Avail and/or special                |
| A                  |                                     |

## TABLE OF CONTENTS

|   |            |
|---|------------|
| LIST OF TABLES . . . . .  | v          |
| LIST OF FIGURES. . . . .  | vi         |
| <b>1.0 <u>INTRODUCTION.</u></b> . . . . .                                   | <b>1-1</b> |
| <b>2.0 <u>EXPERIMENT DESCRIPTION.</u></b> . . . . .                         | <b>2-1</b> |
| 2.1 Participants . . . . .  | 2-1        |
| 2.2 Noise Conditions . . . . .  | 2-8        |
| 2.3 Test Environment and Equipments. . . . .                                | 2-13       |
| 2.4 Response Measures. . . . .  | 2-20       |
| <b>3.0 <u>RESULTS</u></b> . . . . .   | <b>3-1</b> |
| 3.1 Intelligibility. . . . .  | 3-1        |
| 3.2 Temporary Threshold Shift (TTS). . . . .                                | 3-8        |
| 3.3 Noise Annoyance. . . . .  | 3-11       |
| 3.4 Magnitude Estimation . . . . .  | 3-15       |
| 3.5 Variability of Hearing Threshold Determinations. . . . .                | 3-17       |
| and Manifest Anxiety  |            |
| 3.6 Engineering Calculation Procedure Considerations . . . . .              | 3-20       |
| <b>4.0 <u>DISCUSSION AND CONCLUSIONS.</u></b> . . . . .                     | <b>4-1</b> |
| <b><u>REFERENCES</u></b> . . . . .  | <b>R-1</b> |
| <b>APPENDIX A - Instructions for Use of Earplugs.</b> . . . . .             | <b>A-1</b> |
| <b>APPENDIX B - General Experiment Session Instructions</b> . . . . .       | <b>B-1</b> |
| <b>APPENDIX C - Tower-to-Pilot Verbal Communication Materials</b> . . . . . | <b>C-1</b> |

## LIST OF TABLES

- 2-I. Means and ranges for age and education in years . . . . . 2-1  
of 50 participants.
- 2-II. Means and standard deviations (S.D.) for fifty . . . . . 2-3  
participants' baseline audiometric determinations (dB).
- 2-III. Levels in dBA at various locations in commercial. . . . . 2-9  
jet aircraft cockpits.
- 2-IV. Duration and levels for noise conditions (spectrums . . . . . 2-12  
1 and 2 for each condition for a total of 20).
- 2-V. Engineering calculation procedure results for 5 . . . . . 2-18  
exposure positions (narrow-body jets, spectrum 1).
- 2-VI. Engineering calculation procedure results for 5 . . . . . 2-18  
exposure conditions (DC-10-40 aircraft, spectrum 2).
- 3-VII. Post-experimental less Pre-experimental, and . . . . . 3-9  
Post-experimental less Baseline threshold differences  
(TTS) at 500, 1000, 2000, and 4000 Hz (average for  
both ears).
- 3-VIII. Product-moment coefficients of correlation for. . . . . 3-18  
baseline audiometric ranges and manifest anxiety  
test scores (50 pairs at each Hz).
- 3-IX. Correlations between TTS and manifest anxiety . . . . . 3-19  
scores that could be significantly different  
from zero.

LIST OF FIGURES

- 1a. Mean and range of baseline audiograms for participant . . . . . 2-4  
with lowest right ear mean threshold at 1000 Hz  
(right ear).
- 1b. Mean and range of baseline audiograms for participant . . . . . 2-4  
with lowest right ear mean threshold at 1000 Hz  
(Left ear).
- 2a. Mean and range of baseline audiograms for participant . . . . . 2-5  
with highest right ear mean threshold at 1000 Hz  
(right ear).
- 2b. Mean and range of baseline audiograms for participant . . . . . 2-6  
with highest right ear mean threshold at 1000 Hz  
(left ear).
- 3a. Mean and range of baseline audiograms for participant . . . . . 2-7  
with lowest right ear mean threshold at 6000 Hz  
(right ear).
- 3b. Mean and range of baseline audiograms for participant . . . . . 2-7  
with lowest right ear mean threshold at 6000 Hz  
(left ear).
- 4. Composite spectrum for narrow-body commercial jet . . . . . 2-10  
aircraft (spectrum 1).
- 5. Spectrum derived from DC-10-40 measurement program. . . . . 2-11  
(spectrum 2).
- 6. Floor plan of exposure area (not to scale). . . . . 2-14
- 7. Mean and range of octave-band levels at five exposure . . . . . 2-16  
positions for narrow-body commercial jet aircraft  
(spectrum 1).
- 8. Mean and range of octave-band levels at five exposure . . . . . 2-17  
positions for DC-10-40 jet aircraft (spectrum 2).
- 9. Block diagram of systems used to provide simulated. . . . . 2-19  
cockpit noise exposure and speech intelligibility tests.
- 10. Comparison of actual controller's speech spectra and. . . . . 2-24  
that simulated for the presentation of intelligibility tests.
- 11. Percent correct for 70-item word test as a function of. . . . . 3-2  
twenty noise conditions.

LIST OF FIGURES (continued)

12. Average percent correct on 70-item word test for three . . . . 3-5 exposure periods (spectrums 1 and 2).
13. Average percent correct on 70-item word test for three . . . . 3-5 levels (spectrums 1 and 2).
14. Average percent correct for 57-item pre-experiment . . . . . 3-6 word test.
15. Average dB difference between experimental speech levels . . . 3-7 and levels adjusted for comfort (experiment less adjusted level).
16. Average dB difference between experimental speech levels . . . 3-7 and levels adjusted for comfort (experiment less adjusted level).
17. Mean category scaling of "how annoying" for total session. . . 3-13
18. Category scaling of "how annoying" for total session . . . . . 3-14 with mean results based on spectrum, duration (hours) and level.
19. Magnitude estimation ratings as a function of exposure . . . . 3-16 level.
20. Engineering calculation procedure differences between. . . . . 3-21 the two spectra (spectrum 1 less spectrum 2).

## COMMERCIAL AIRCRAFT FLIGHT DECK NOISE CRITERIA

### 1.0 INTRODUCTION

There is considerable interest in establishing noise level limits that will protect persons who work in high level noise environments from noise-induced permanent threshold shifts (NIPTS). Flight deck environments of some commercial airplanes may provide high enough noise levels that questions concerning noise-induced permanent threshold shifts would be in order. Along with the NIPTS problem there is the additional consideration that communication among flight personnel and with controllers is essential, and that flight deck noise levels should not mask communications. These two problems, the possibility of noise-induced permanent threshold shift and the requirement for adequate communications, are emphasized in this study program. Thus, the two main measures employed are:

- 1) Measures of noise-induced hearing threshold shifts as a function of realistic simulations of commercial aircraft flight deck noise environments.
- 2) The effect on communication performance of realistic simulations of commercial aircraft flight deck noise environments.

## 2.0 EXPERIMENT DESCRIPTION

So that results could be obtained concerning the possibility of noise-induced permanent threshold shift and communications interference, fifty persons were employed and exposed to various commercial jet aircraft cockpit noise environments. The various aspects of the program are:

- Selection and training of participants.
- Noise conditions, which includes selection of spectra, level and duration.
- Test environment and equipments.
- Response measures, which emphasized a realistic communications task and temporary threshold shift (TTS) determinations but also included magnitude estimation and category ratings for the various conditions.

## 2.1 Participants

Subjects were recruited from the University of Washington and selected on the basis of an audiometric screening test with the requirement that one ear pure tone thresholds at 0.5, 1, 2, and 4 kHz were not greater than 10 dB from audiometric zero using ANSI 1969 standards. The 50 persons selected were equally divided as to gender. Age and educational information is provided in Table 2-I.

Table 2-I. Means and ranges for age and education in years of 50 participants.

|       | AGE     | EDUCATION |
|-------|---------|-----------|
| Mean  | 23.1    | 15.5      |
| Range | 18 - 39 | 12 - 23   |

During the screening interview a brief history of occupational and recreational activities was obtained with the aim of obtaining some indication of possible excessive noise exposure. In addition, each participant responded to a ten-item noise sensitivity test (Ref. 1) and to a 50-item test aimed at measuring manifest anxiety (Ref. 2). The interest in the latter test involves the possibility that high anxious persons may have greater difficulty in determining their auditory thresholds. Thus, it would be expected that there would be a positive relationship between scores on a manifest anxiety test and range of threshold for repeated audiometric determinations. So as to obtain a more stable baseline for the auditory thresholds of interest and also to train participants in tower-to-pilot communication skills, each participant completed five 45-minute training sessions (Monday through Friday) prior to taking part in the experiment. Each 45-minute training session included the following:

- Manual pure tone audiometry at 250, 500, 1000, 2000, 4000, 6000, and 8000 Hz.
- Training with tower-to-pilot words and phrases so that any degradation of response due to noise exposure could not be attributed to unfamiliarity.
- Exposure to USASI noise at 80 dBA for two minutes which was to be utilized as a standard to which the experimental sessions would be compared.

During these five pre-experiment sessions, headphones were refitted and the audiometric test was repeated for most of the subjects. Thus, short-term and headphone-fit effects would be included in the baseline variability and also subjects' baseline thresholds would be based on ten threshold determinations. Means and standard deviations (S.D.) of thresholds for the 50 participants using all baseline threshold measurements

are given in Table 2-II.

Table 2-II. Means and standard deviations (S.D.) for fifty participants' baseline audiometric determinations (dB).

|              |      | Hz  |     |      |      |      |      |      |
|--------------|------|-----|-----|------|------|------|------|------|
|              |      | 250 | 500 | 1000 | 2000 | 4000 | 6000 | 8000 |
| RIGHT<br>EAR | Mean | 1.4 | 2.1 | 1.7  | -1.0 | 1.4  | 12.0 | 6.2  |
|              | S.D. | 4.4 | 5.2 | 5.2  | 4.3  | 7.5  | 8.9  | 8.6  |
| LEFT<br>EAR  | Mean | 2.8 | 1.9 | 1.7  | 1.4  | 2.4  | 14.8 | 8.6  |
|              | S.D. | 4.9 | 4.5 | 4.9  | 5.2  | 6.2  | 9.3  | 8.4  |

Since the results of Table 2-II are based on means or averages for some 500 baseline audiometric examinations (50 persons examined on 10 occasions), for illustrative purposes, results for three individual participants are provided in Figures 1a. through 3b. Figures 1a. and 1b. provide plots for the person with the right ear lowest threshold at 1000 Hz. Of all 50 participants, only this one subject detected all presentations of the 1000 Hz tone at -10 dB from audiometric zero. Hearing in the left ear was almost as acute at 1000 Hz with the mean of the threshold determinations at -8 dB from audiometric zero. The general shape of the audiograms is similar for both ears. Hearing is most acute between 250 to 2000 Hz with mean drops at 6000 Hz to +20 dB from audiometric zero for both ears. The audiograms of Figures 2a. and 2b. are based on threshold determinations by the participant with the highest right ear mean threshold at 1000 Hz with a mean baseline level of +13 dB from audiometric zero. As for the subject with the "best" hearing at 1000 Hz in the right ear (Figures 1a. and 1b.), hearing acuity decreases or dips at 6000 Hz, reaching a mean level of +30 dB from audiometric zero for the left ear. Since the two

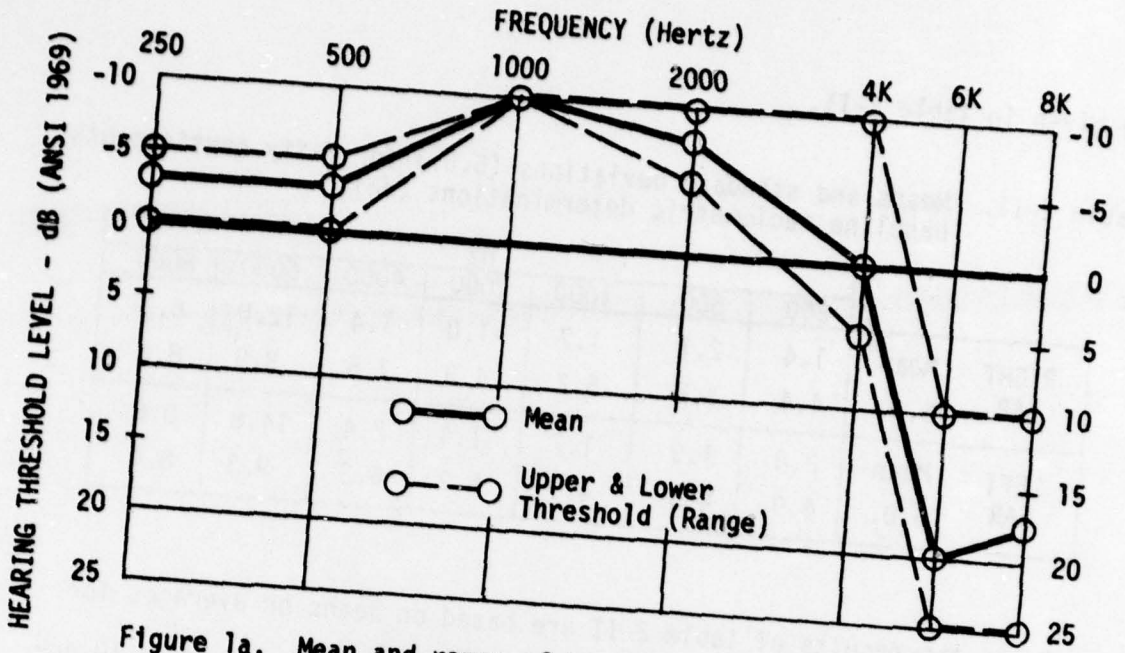

Figure 1a. Mean and range of baseline audiograms (RIGHT EAR) for participant with lowest right ear mean threshold at 1000 Hz.

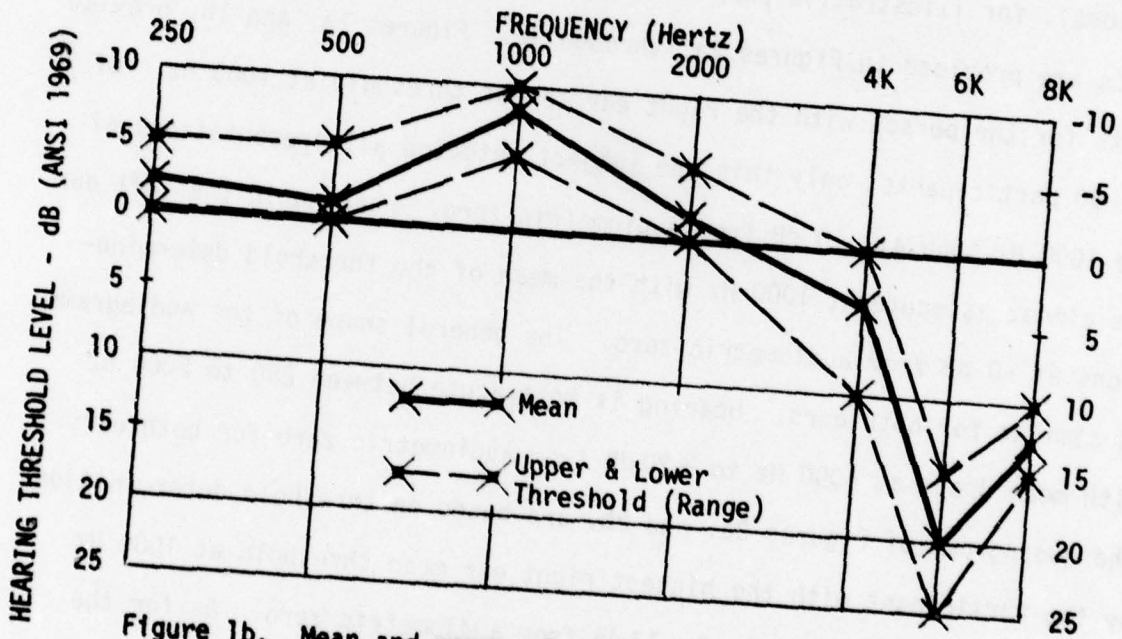

Figure 1b. Mean and range of baseline audiograms (LEFT EAR) for participant with lowest right ear mean threshold at 1000 Hz.

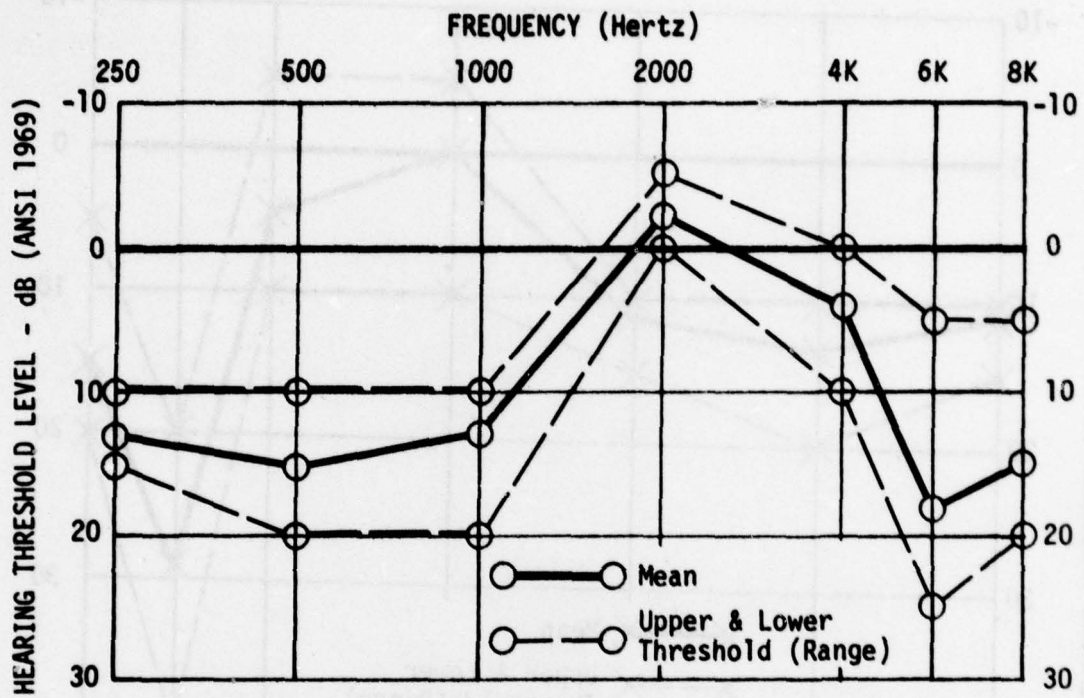

Figure 2a. Mean and range of baseline audiograms (RIGHT EAR) for participant with highest right ear mean threshold at 1000 Hz.

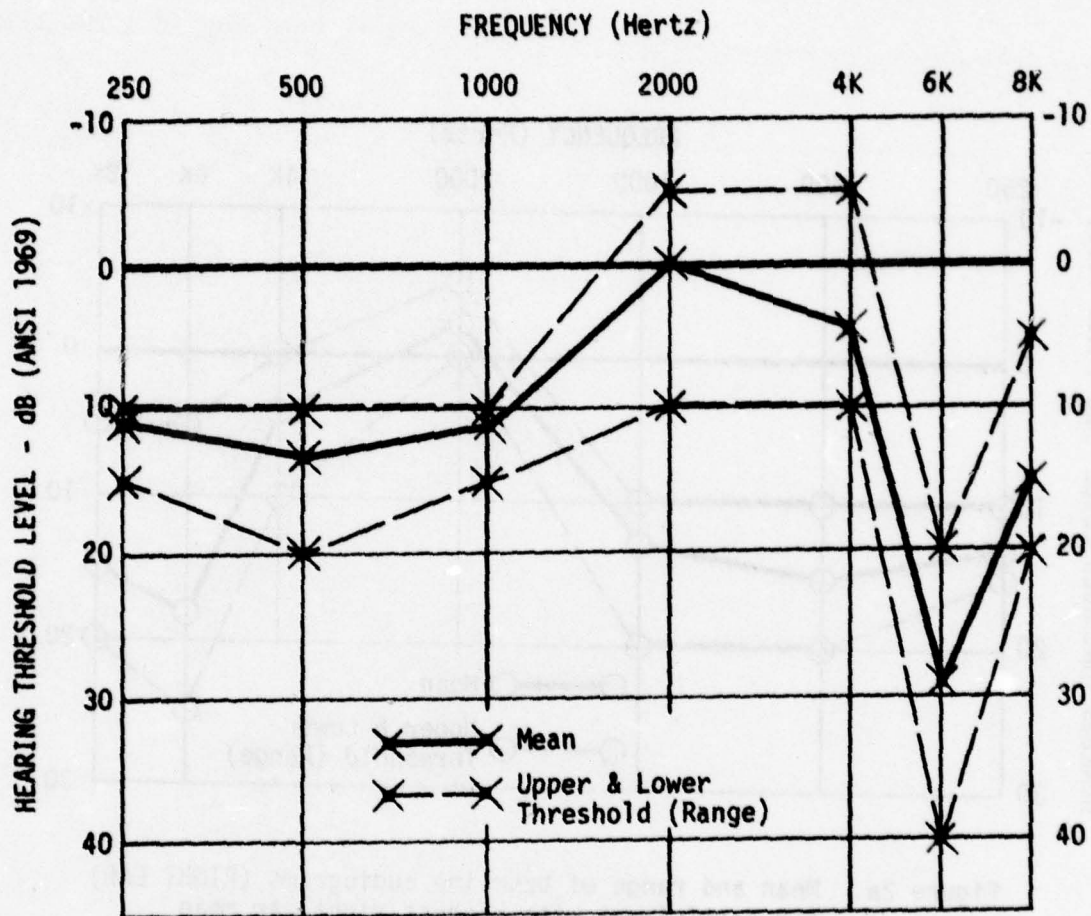

Figure 2b. Mean and range of baseline audiograms (LEFT EAR) for participant with highest right ear mean threshold at 1000 Hz.

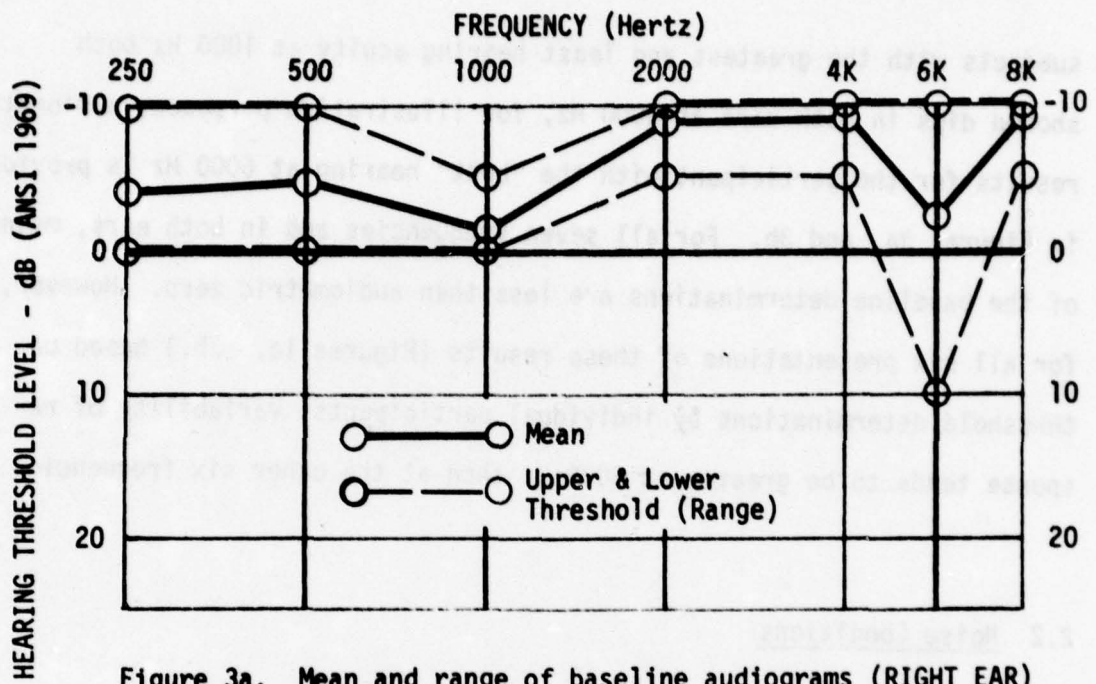

Figure 3a. Mean and range of baseline audiograms (RIGHT EAR) for participant with lowest right ear mean threshold at 6000 Hz.

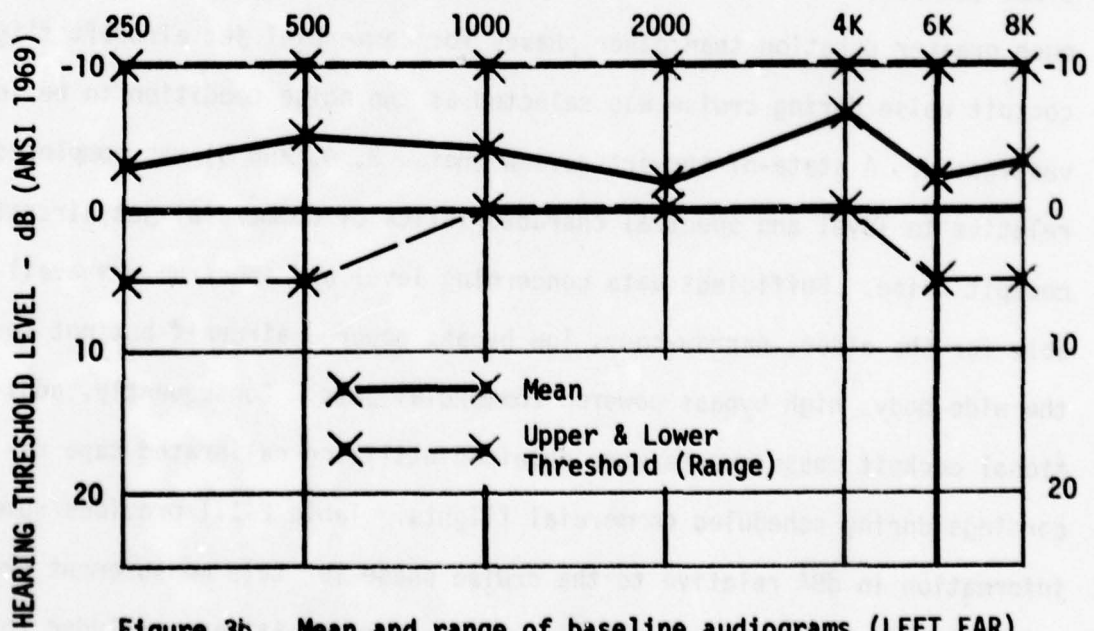

Figure 3b. Mean and range of baseline audiograms (LEFT EAR) for participant with lowest right ear mean threshold at 6000 Hz.

subjects with the greatest and least hearing acuity at 1000 Hz both showed dips in both ears at 6000 Hz, for illustrative purposes, audiometric results for the participant with the "best" hearing at 6000 Hz is provided in Figures 3a. and 3b. For all seven frequencies and in both ears, means of the baseline determinations are less than audiometric zero. However, for all six presentations of these results (Figures 1a. - 3b.) based on threshold determinations by individual participants, variability of response tends to be greater at 6000 Hz than at the other six frequencies.

## 2.2 Noise Conditions

Both level and spectral characteristics change as a function of operations (takeoff, cruise, descent). However, since the cruise phase is of much greater duration than other phases for commercial jet aircraft flights, cockpit noise during cruise was selected as the noise condition to be investigated. A state-of-the-art review (Refs. 3, 4, and 5) was completed relative to level and spectral characteristics of commercial jet aircraft cockpit noise. Sufficient data concerning level and spectrum was available for the older, narrow-body, low bypass powered aircraft but not for the wide-body, high bypass powered commercial jets. Consequently, additional cockpit measurements were obtained utilizing calibrated tape recordings during scheduled commercial flights. Table 2-III provides summary information in dBA relative to the cruise phase for this measurement program. Based on the review and measurement program, it was concluded that cockpit noise levels at cruise in commercial jet aircraft ranges from approximately 72 to 86 dBA, depending on the measurement location and opera-

Table 2-III. Levels in dBA at various locations in commercial jet aircraft cockpits.

| AIRCRAFT | ALTITUDE | INDICATED AIR SPEED | MEASUREMENT LOCATION |      |      |
|----------|----------|---------------------|----------------------|------|------|
|          |          |                     | *A                   | B    | C    |
| DC-10-10 | 39 K ft. | 260 Knots           | 71.6                 | 73.6 | 70.0 |
| 747      | 37 " "   | 270 "               | 77.0                 | 80.2 | 79.1 |
| 747      | 41 " "   | 250 "               | 75.9                 | 79.0 | 76.5 |
| 727-200  | 35 " "   | 280 "               | 79.1                 | 81.6 | 78.4 |
| 727-200  | 22 " "   | 335 "               | 81.4                 | 85.3 | 80.9 |

\* "A" Measured between pilot and copilot at ear level.

"B" Measured between captain's left ear and window.

"C" Three to six inches from 2nd officer's (Flight Engineer) left ear.

tional characteristics. Two cruise spectra were selected. The first (spectrum 1) is based on measurements in the cockpits of a number of conventional narrow-body jet aircraft (DC-9, 707, 720, 727) which were combined to produce a composite spectrum as shown in Figure 4 (Ref. 3). This composite spectrum representing narrow-body jets is relatively flat across the frequency range and peaks around 1000 Hz. The second spectrum (spectrum 2) was obtained from cruise measurements in the cockpit of the DC-10-40 and has a pronounced drop from the low to high frequencies as shown in Figure 5. Figures 4 and 5 present the two spectra at 80 dBA.

The original spectra on which spectrum 1 is based provided dBA levels between 80 and 86 and the actual levels for spectrum 2 were in the 71 to 75 dBA range. So that results might have general application to commercial jet aircraft noise effects problems, subjects were exposed to three levels of each spectrum ranging from 75 to 85 dBA in 5 dBA increments. In respect to duration of exposure, there was interest in spanning the

ADD 4.9 DB TO OBTAIN OCTAVE BAND LEVEL

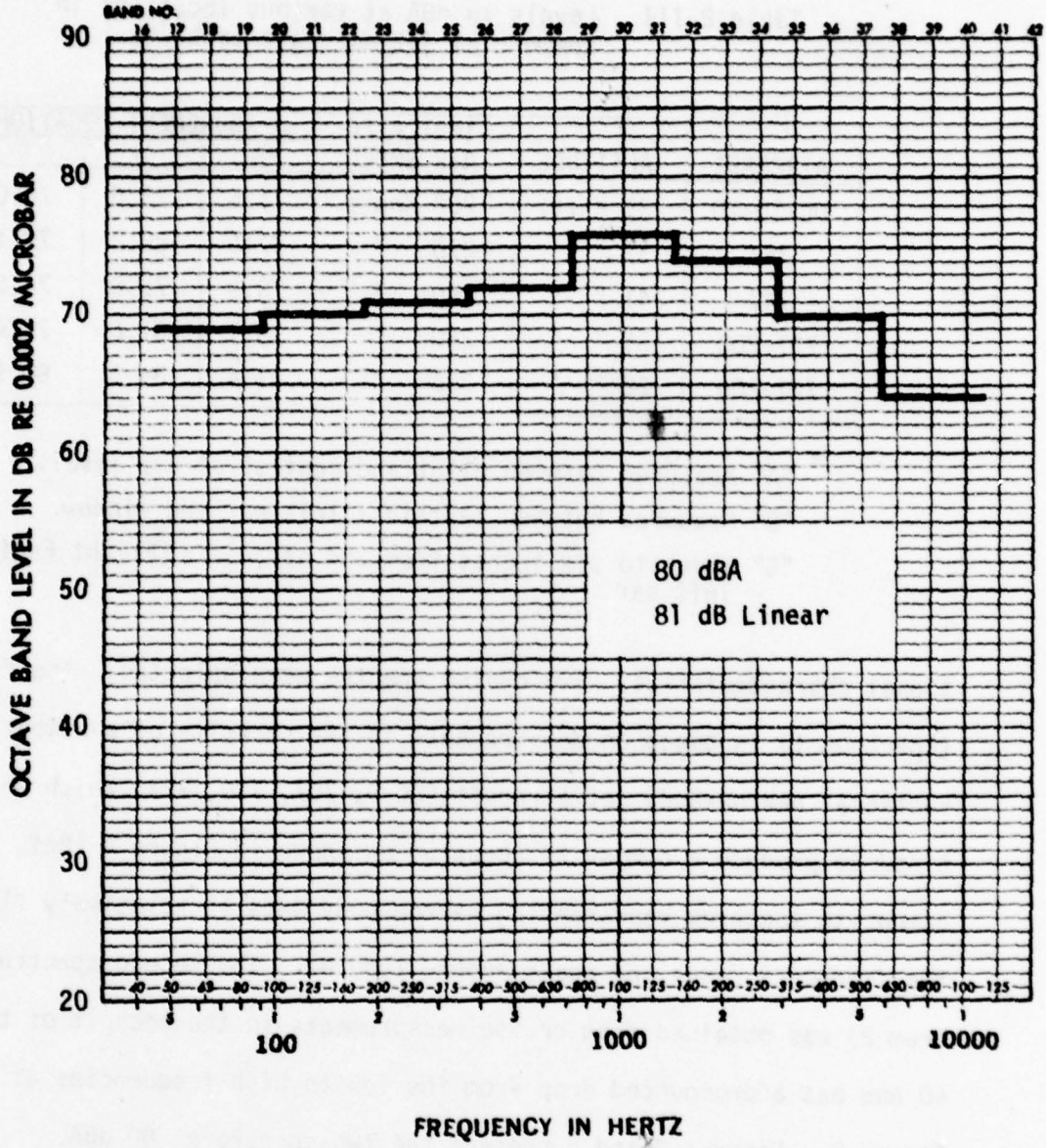

Figure 4. Composite spectrum for narrow-body commercial jet aircraft. (SPECTRUM 1)

ADD 49 DB TO OBTAIN OCTAVE BAND LEVEL

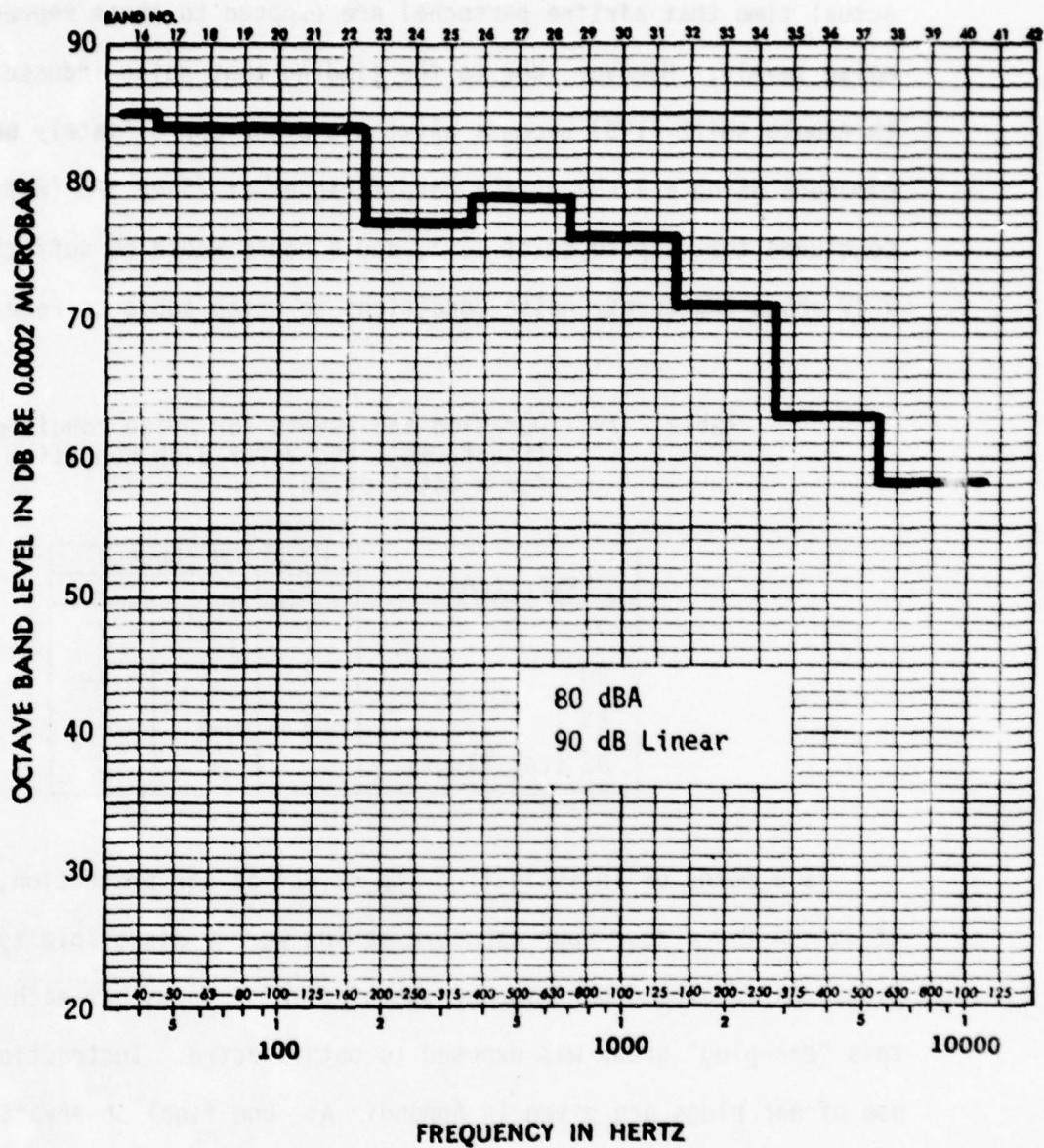

Figure 5. Spectrum derived from DC-10-40 measurement program.  
(SPECTRUM 2)

actual time that airline personnel are exposed to these representative noise levels. However, due to the finding that noise-induced temporary threshold shift (TTS) becomes asymptotic after approximately one hour of exposure using a 4 kHz octave band fatiguer at 75 dB SPL (Ref. 6), it was concluded that exposures of 1, 2, and 4 hours would be sufficient. Table 2-IV shows the twenty noise conditions to which subjects were exposed.

Table 2-IV. Duration and levels for noise conditions (Spectrums 1 and 2 for each condition for a total of 20).

| LEVEL (dBA)    | DURATION (hours) |   |   |
|----------------|------------------|---|---|
|                | 1                | 2 | 4 |
| 75             | X                | X | X |
| 80             | X                | X | X |
| 85             | X                | X | X |
| 85 (Ear Plugs) |                  |   | X |

As a means of investigating the effect of ear protection, one group at 85 dBA for a four-hour exposure period wore a disposable type of ear plug. As for the other nine groups of five subjects per each condition, this "ear-plug" group was exposed to both spectra. Instructions concerning use of ear plugs are given in Appendix A. One final observation concerning the two noise spectra investigated involves the large difference of their overall sound pressure levels if matched using the dBA weighting network. For example, at 80 dBA (Figures 4 & 5), dB linear for spectrum 1 is 81 and for spectrum 2 it is 90.

### 2.3 Test Environment and Equipments

The experiment was conducted in a comfortably furnished room containing a couch, easy chairs, coffee table and carpet; the layout of the room is shown in Figure 6. Unless utilizing the adjacent kitchen area or rest rooms, subjects were required to sit in one of the five numbered exposure positions. Coffee and soft drinks were available and persons taking part in the experiment were permitted to use the time at their own discretion. Some read or studied while others would occasionally sleep.

Eight Speakerlab-2 3-way sealed-box system loudspeakers were distributed so as to produce a uniform sound field throughout the room. They were powered in pairs (Loudspeaker columns in Figure 6) in series by two two-channel amplifiers (MacIntosh 2100 and 250). The two cockpit noise spectra were produced by passing pink noise from a GenRad 1382 noise generator through a Dynaco SE-10 two-channel equalizer, one channel of which was set up to produce spectrum 1 (narrow-body cockpit noise) and the other to provide spectrum 2 (wide-body cockpit noise). The output of the equalizer was split between the two amplifiers and a subsidiary system which provided cockpit noise to the kitchen area and restrooms. As shown in Figure 6, five exposure positions were used so that five persons could be exposed simultaneously to any one of the twenty noise conditions. The two test spectra were adjusted to give 80 dBA at exposure position #4 which was used for all intelligibility testing. Level and spectra were then measured at all five positions, using a GenRad 1962-9601 1/2" electret microphone and 1560-P42 preamplifier connected to a GenRad 1921 real-time analyzer which was controlled by a PDP-11 computer. The results of this

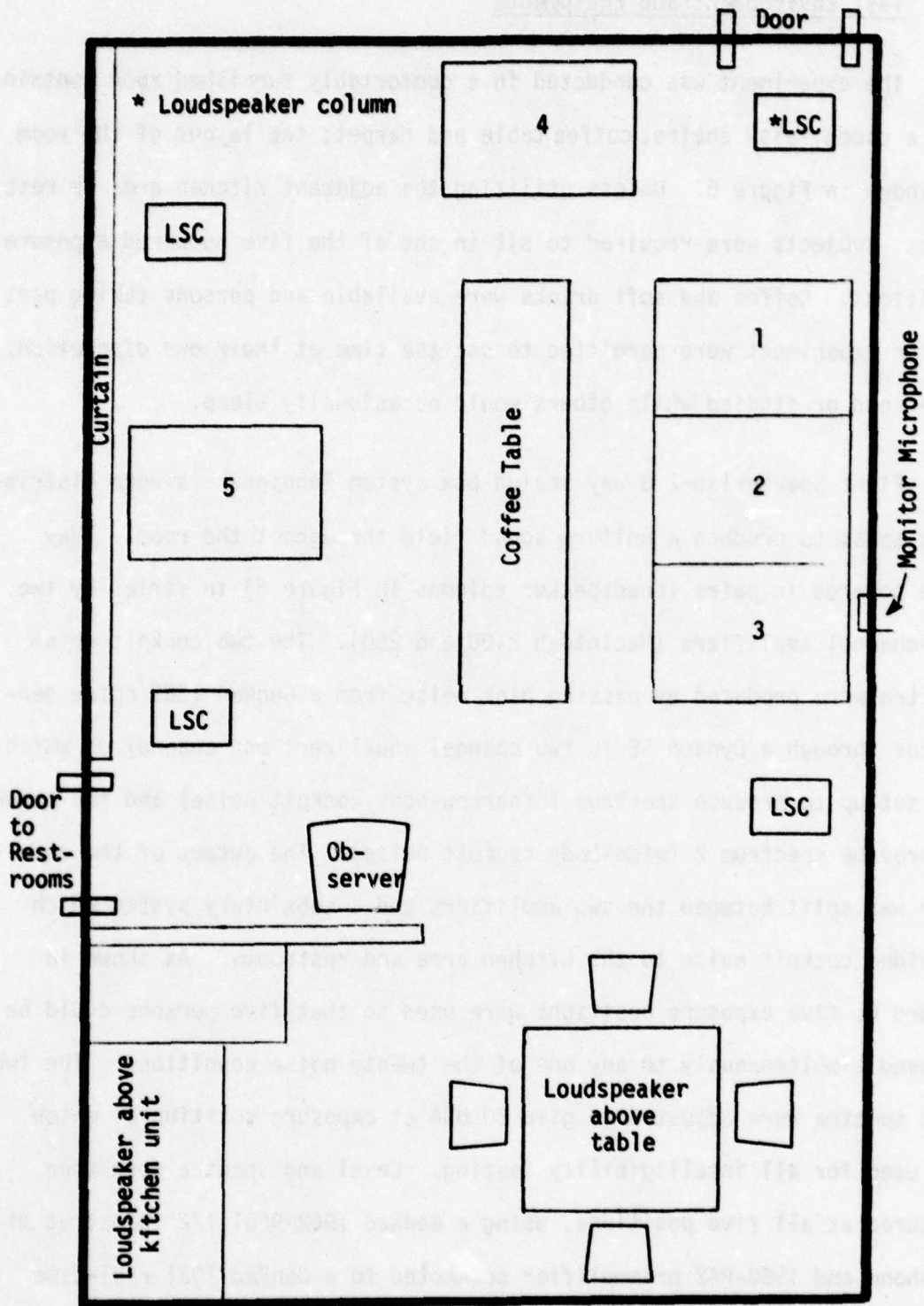

Figure 6. Floor plan of exposure area (not to scale).

measurement program are given in Figures 7 and 8 which provide the mean level based on all five exposure positions and maximum and minimum levels (range) for the five positions over eight octave bands. Correspondence between the exposure position spectra and derived spectra (Figure 7 vs. Figure 4 and Figure 8 vs. Figure 5) is considered quite satisfactory. For noise from 500 to 8K Hz, the range of octave-band levels across exposure positions averages 1.2 dB for spectrum 1 noise, and 1.5 dB for spectrum 2 noise. Tables 2-V and 2-VI provide engineering calculation procedure results for the five exposure positions. The levels in the kitchen and restroom areas were set to give the same dBA levels as experienced at the five exposure positions but there was no attempt to replicate the two spectra as for the five exposure positions. During presentation of any one of the twenty experimental conditions, levels in the room were monitored during the experiment via a Bruel and Kjaer 4117 1" microphone and 2205 sound level meter connected to a B&K 2307 level recorder.

The intelligibility test was presented via a Planatronics MS-50 headset which utilizes a fitted ear insert. The test was recorded on a TEAC 3300 tape recorder and presented via an attenuator system through an SAE Mark 30 preamplifier to the headset. The system consisted of two attenuators in parallel, the signal being routed through one attenuator by a switch under the control of the experimenter. The attenuator under control of the experimenter was kept fixed so as to control the level of the intelligibility test while the second, a single-knob rotary attenuator graduated in 1.5 dB steps, was used by the subject to adjust the speech to a level that he considered comfortable. Subjects adjusted the speech level at the termination of the intelligibility test as a means of determining

ADD 4.9 DB TO OBTAIN OCTAVE BAND LEVEL

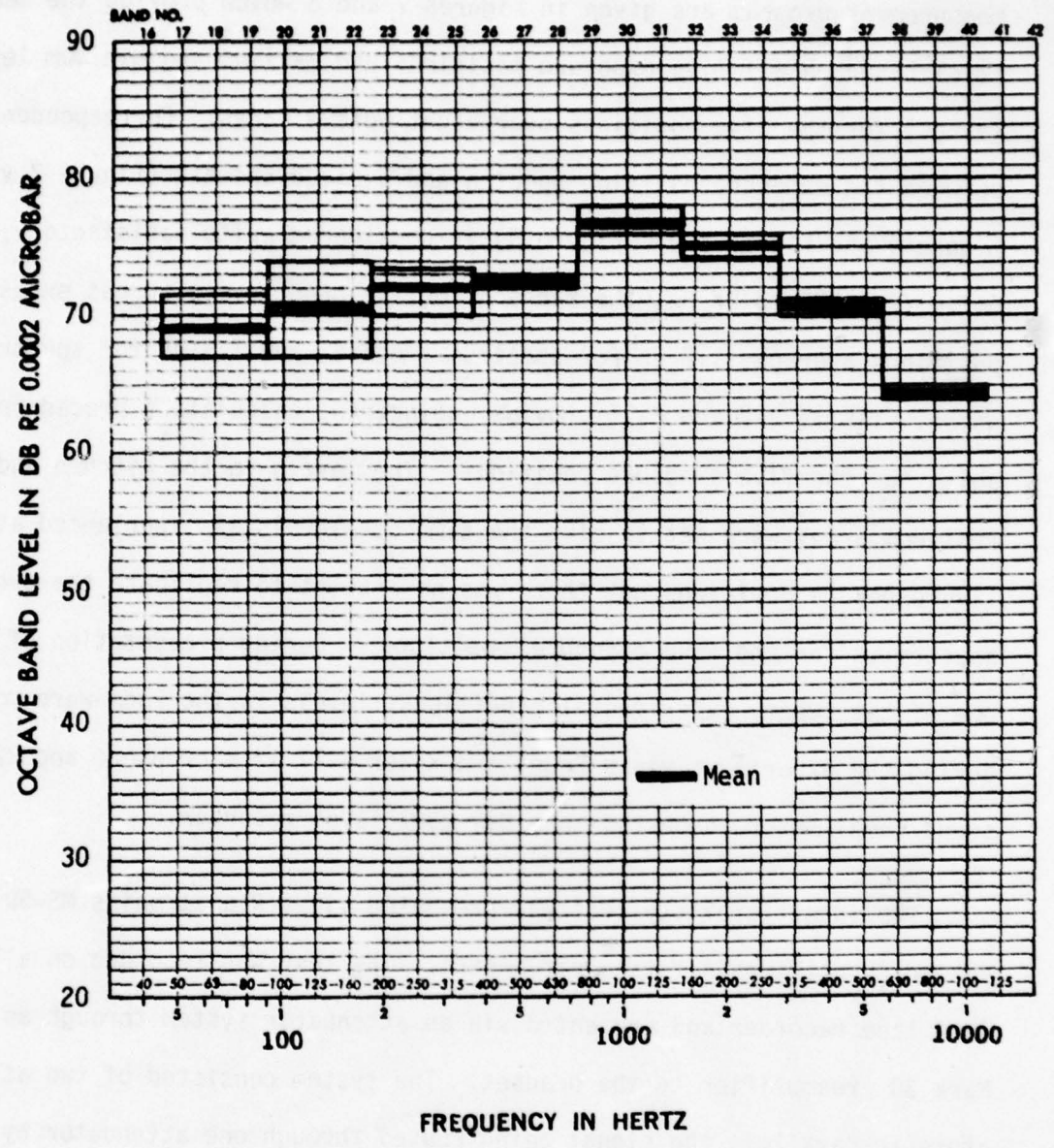

Figure 7. Mean and range of octave-band levels at five exposure positions for narrow-body commercial jet aircraft. (SPECTRUM #1)

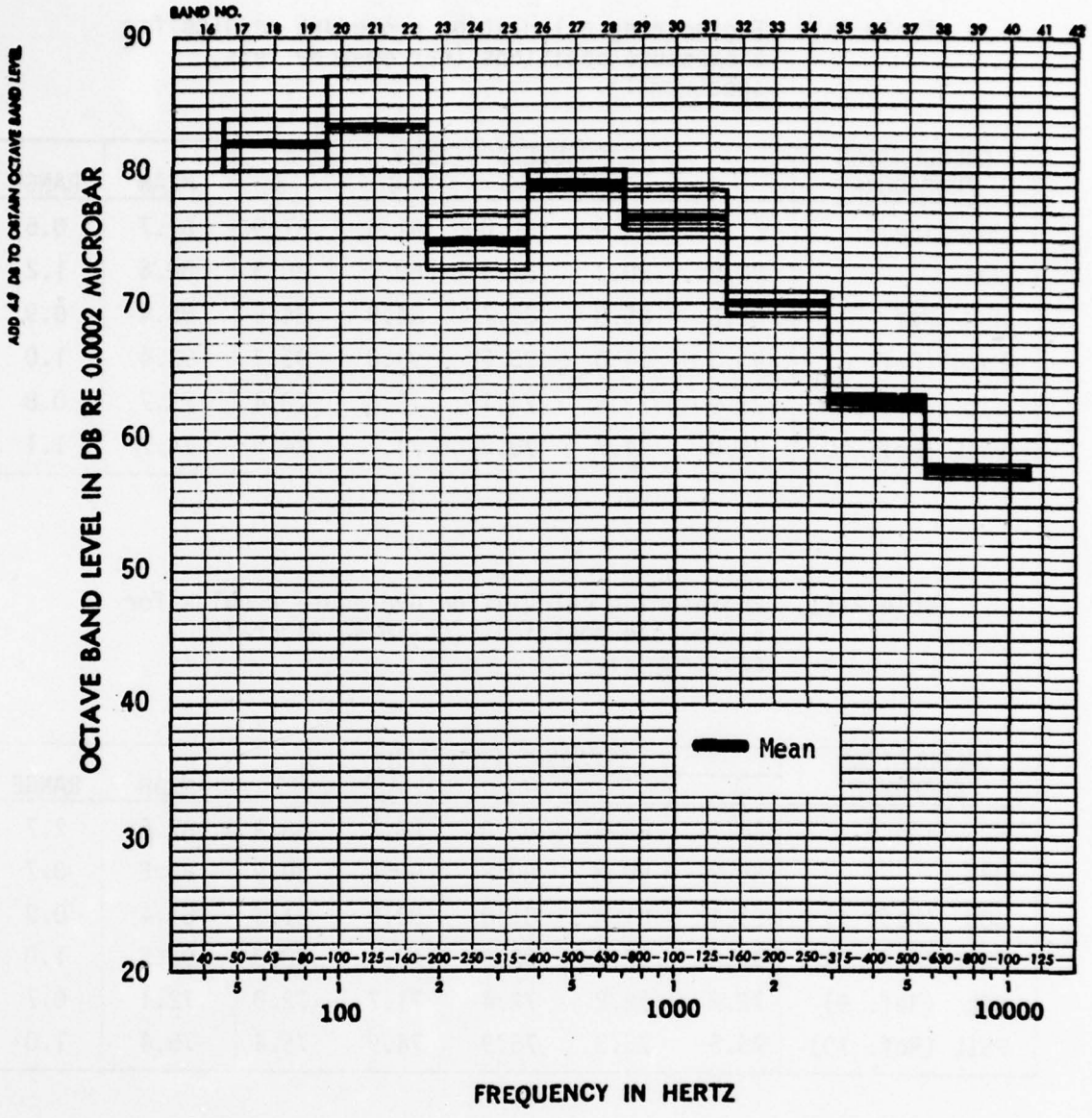

Figure 8. Mean and range of octave-band levels at five exposure positions for DC-10-40 jet aircraft. (SPECTRUM #2)

Table 2-V. Engineering calculation procedure results for 5 exposure positions (narrow-body jets, spectrum 1).

| CALCULATION PROCEDURE | EXPOSURE POSITION |      |      |      |      | MEAN | RANGE |
|-----------------------|-------------------|------|------|------|------|------|-------|
|                       | 1                 | 2    | 3    | 4    | 5    |      |       |
| dB - linear           | 81.4              | 81.9 | 82.0 | 81.5 | 81.9 | 81.7 | 0.6   |
| dBA                   | 80.8              | 80.7 | 81.3 | 80.1 | 80.3 | 80.6 | 1.2   |
| dBH (Ref. 7)          | 85.6              | 85.8 | 85.7 | 84.9 | 84.9 | 85.4 | 0.9   |
| PNdB (Ref. 8)         | 93.3              | 94.0 | 93.5 | 93.0 | 93.3 | 93.4 | 1.0   |
| SIL (Ref. 9)          | 73.9              | 73.8 | 74.1 | 73.3 | 73.4 | 73.7 | 0.8   |
| PSIL (Ref. 10)        | 75.0              | 74.7 | 75.2 | 74.1 | 74.5 | 74.7 | 1.1   |

Table 2-VI. Engineering calculation procedure results for 5 exposure positions (DC-10-40 aircraft, spectrum 2).

| CALCULATION PROCEDURE | EXPOSURE POSITION |      |      |      |      | MEAN | RANGE |
|-----------------------|-------------------|------|------|------|------|------|-------|
|                       | 1                 | 2    | 3    | 4    | 5    |      |       |
| dB - linear           | 86.2              | 87.9 | 87.0 | 88.1 | 88.9 | 87.6 | 2.7   |
| dBA                   | 80.2              | 80.3 | 80.8 | 80.2 | 80.9 | 80.5 | 0.7   |
| dBH (Ref. 7)          | 81.4              | 81.4 | 81.8 | 80.9 | 81.3 | 81.4 | 0.9   |
| PNdB (Ref. 8)         | 92.0              | 92.7 | 92.3 | 92.4 | 93.0 | 92.5 | 1.0   |
| SIL (Ref. 9)          | 72.2              | 72.2 | 72.4 | 71.7 | 72.0 | 72.1 | 0.7   |
| PSIL (Ref. 10)        | 75.5              | 75.3 | 75.9 | 74.9 | 75.4 | 75.4 | 1.0   |

agreement between that used in the experiment and speech level rated as "comfortable" by the subjects. The level of the signal going to the headset was monitored on a B&K 2307 level recorder. A block diagram of the equipments is shown in Figure 9.

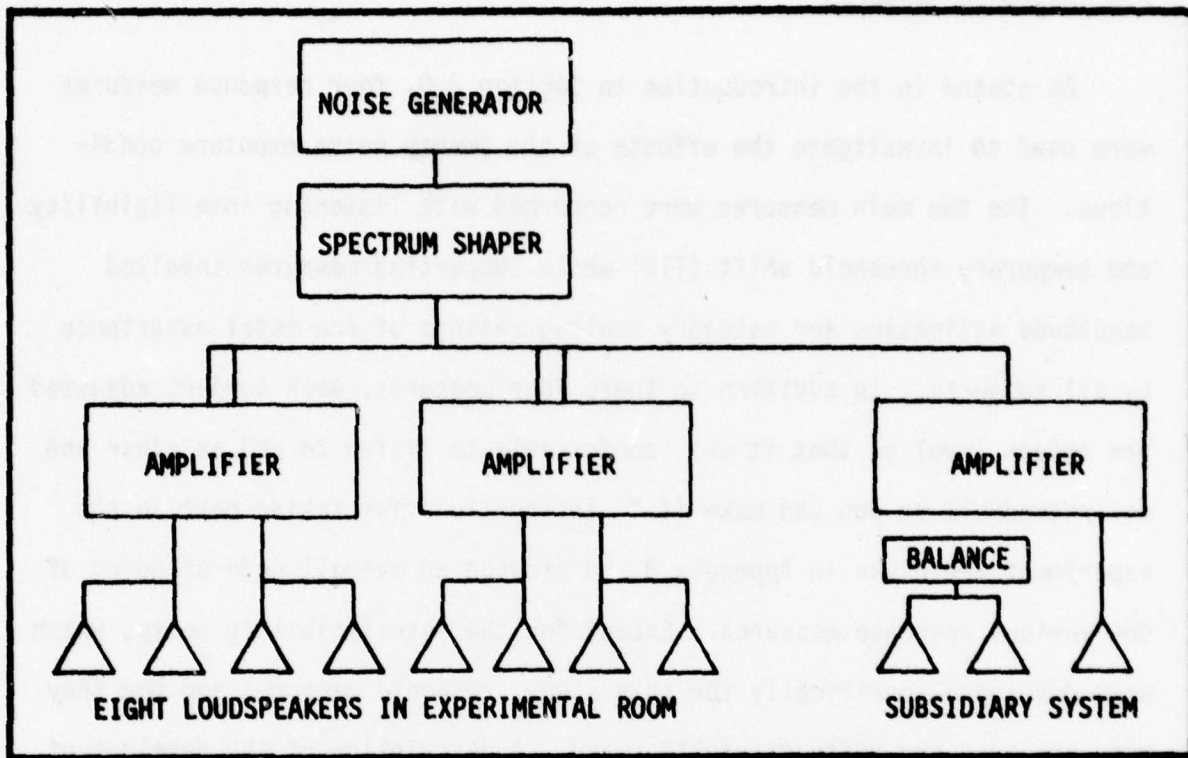

Cockpit Noise Presentation System

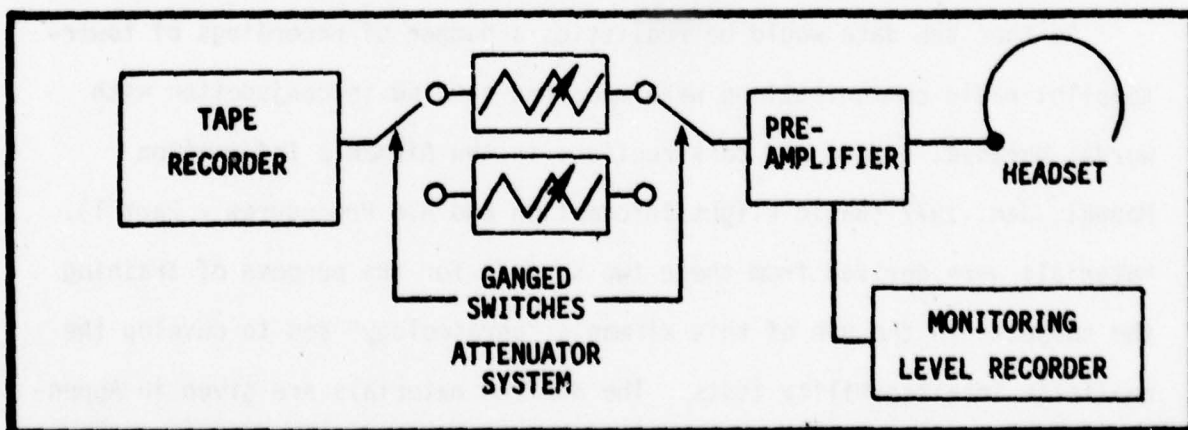

System for Presenting Noise Intelligibility Tests

Figure 9. Block diagram of systems used to provide simulated cockpit noise exposure and speech intelligibility tests.

## 2.4 Response Measures

As stated in the introduction to Section 2.0, four response measures were used to investigate the effects of the twenty noise exposure conditions. The two main measures were concerned with listening intelligibility and temporary threshold shift (TTS) while supporting measures involved magnitude estimation and category scaling ratings of the total experience by all subjects. In addition to these four measures, each subject adjusted the speech level so that it was "comfortable to listen to and as clear and understandable as you can make it." Instructions for taking part in the experiment are given in Appendix B and provide an overall understanding of the various response measures. Except for the intelligibility tests, which were developed specifically for this study, response measures and how they were employed are quite straightforward. A description of the development and use of the intelligibility tests follows.

So that the data would be realistic, a number of recordings of tower-to-pilot radio communications were made and studied in conjunction with words, phrases, usages and constructions in the Airman's Information Manual, Jan. 1977 (Basic Flight Information and ATC Procedures - Part 1). Materials were derived from these two sources for the purpose of training the subjects in the use of this airman's "phraseology" and to develop the realistic intelligibility tests. The derived materials are given in Appendix C and include a list of "Special words", "Typical Phraseology", and a "Glossary". All of these Appendix C materials were provided to all 50 subjects and also used in their five 45-minute training sessions prior to taking part in the experiment. During the first four training sessions,

they listened to a recording of various tower-to-pilot phrases replayed through a headset. For these practice sessions, they were provided with a typewritten copy of the phrases so that they could clearly understand the material. For the fifth training sessions, they listened to the 14 phrases selected as the "training intelligibility test" and wrote the phrases on an answer sheet. These 14 phrases are:

#### TRAINING INTELLIGIBILITY TEST

- |                          |                               |
|--------------------------|-------------------------------|
| 1. Climb to 14,000.      | 8. Turn on your transponder.  |
| 2. Taxi to runway 35.    | 9. Traffic at 10 o'clock.     |
| 3. Maintain 1500.        | 10. Hold short 07.            |
| 4. Turn left 10 degrees. | 11. Wind 326 at 8.            |
| 5. Squawk 9683.          | 12. Resume normal navigation. |
| 6. Ceiling 25,000.       | 13. Well below glidepath.     |
| 7. ILS runway 25 right.  | 14. Visibility 2.             |

Scores on this end-of-training test provided a measure of their training and would also serve as a comparison or baseline test relative to performance on the experiment intelligibility test. Following are the 14 phrases used in the "experiment intelligibility test":

#### EXPERIMENT INTELLIGIBILITY TEST

1. Clear to land zero four left.
2. Squawk four one six three.
3. Contact departure seven four zero three.
4. Traffic at two o'clock.
5. Tower will be three five one nine.
6. Reduce your speed by fifty knots.
7. Intercept the localizer.

EXPERIMENT INTELLIGIBILITY TEST (cont'd)

8. Slightly above glidepath.
9. Altimeter two eight nine seven.
10. Descend to fourteen hundred.
11. Turn left heading one nine eight.
12. Reduce your speed to fifty knots.
13. Turn right heading zero seven six.
14. Caution wake turbulence.

These fourteen phrases were used for all four experimental intelligibility testings (pre and post spectrum 1 conditions, pre and post spectrum 2 conditions), but were presented in four different orders so that any tendency to memorize phrases would be decreased.

A final consideration concerning the intelligibility testing involves mode of presenting the tests, spectral characteristics and level. As indicated previously, a Planatronics MS-50 monaural headset was used to present the intelligibility tests. The choice was among a cockpit loudspeaker, headphones, and the monaural headset with a size range (off-the-shelf) of insert eartips. The cockpit loudspeaker approach was rejected as it was necessary for the test to be inaudible to subjects other than the one being tested. Also, an informal survey of airline pilots showed a preference for the lighter, monaural headset. Consequently, the monaural headset was selected with the additional consideration that it would provide less attenuation than a pair of headphones and thus would be representative of a "worst case" situation. So that the speech spectrum for the experiment would be representative for commercial aircraft communications, a number of quality tape recordings were made from the output jacks of receivers in

747 and DC-10 airliners. Communications from a variety of controllers and over a range of distances were obtained. The recordings were analyzed into 1/3-octave bands and the results averaged to produce a "standard" controller's spectrum. The experiment speech signals were picked up by a crystal microphone and passed through a GenRad 1925 1/3-octave band spectrum shaper which was set to simulate the "standard" controller's spectrum. Spectra from the simulation and the average of the actual spectra are shown in Figure 10. The shapes of the two spectra are similar but the simulation is some 8 dB too high at 315 Hz and some 9 dB too low at 3150 Hz. Both of these frequencies do not significantly contribute to the speech frequency range so these differences are not considered as being critical. The intelligibility tests were recorded by a male, trained in communications who imitated a "typical" controller's speech patterns. The signals were presented at the same dBA level (RMS values) as the noise exposure levels. For example, if a subject were exposed and tested at 75 dBA, the intelligibility tests were presented at 75 dBA. Depending on the attenuation of the earpiece, which is very much a function of the fit, signal-to-noise ratio of speech signals to exposure noise was from 5 to 10 dBA.

ADD 4.9 DB TO OBTAIN OCTAVE BAND LEVEL

THIRD-OCTAVE BAND LEVEL IN DB RE 0.0002 MICROBAR

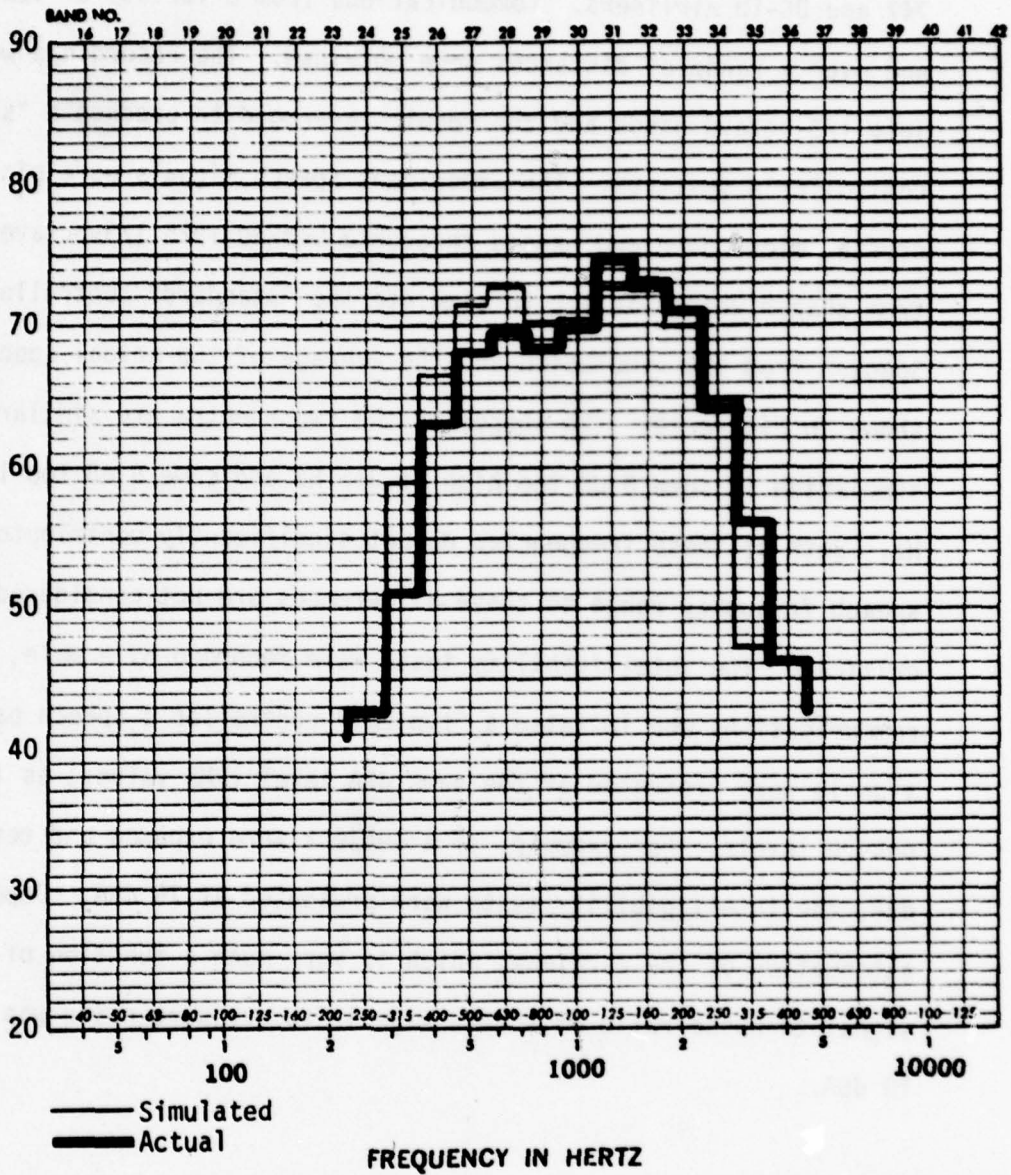

Figure 10. Comparison of actual controller's speech spectra and that simulated for the presentation of intelligibility tests.

### 3.0 RESULTS

#### 3.1 Intelligibility

The premise relative to speech intelligibility testing (controller to pilot) was that exposure over various time periods to a particular noise environment could degrade speech intelligibility. Thus, participants were tested in a particular noise environment, exposed to that same noise environment for one, two, or four hours, and then retested. All aspects of both "before" and "after" testing were the same including the level at which the speech materials were presented. The results for this part of the study are given in Figure 11. Comparing percent correct on the 70-item word test for "before" and "after" exposure shows no specific pattern of speech intelligibility degradation. For the twenty comparisons of Figure 11, fourteen show an increase in intelligibility test scores after exposure to noise, four comparisons show no change, while but two of the comparisons suggest a slight degradation of speech intelligibility. Differences which are appreciable are in the direction of improvement in intelligibility as a function of noise exposure. These differences which show appreciable improvement are:

- Spectrum #2, 1-hour exposure group at 85 dBA. Shows an average score of 82% correct for "before" testing and 91% correct for "after" testing. Improvement is 9 percentage points.
- Spectrum #1, 4-hour exposure group at 85 dBA. Shows an average score of 79% correct for "before" testing and 95% correct for "after" testing. Improvement is 16 percentage points.
- Spectrum #1, 4-hour exposure group at 85 dBA, wearing ear protection (EP). Shows an average score of 83%

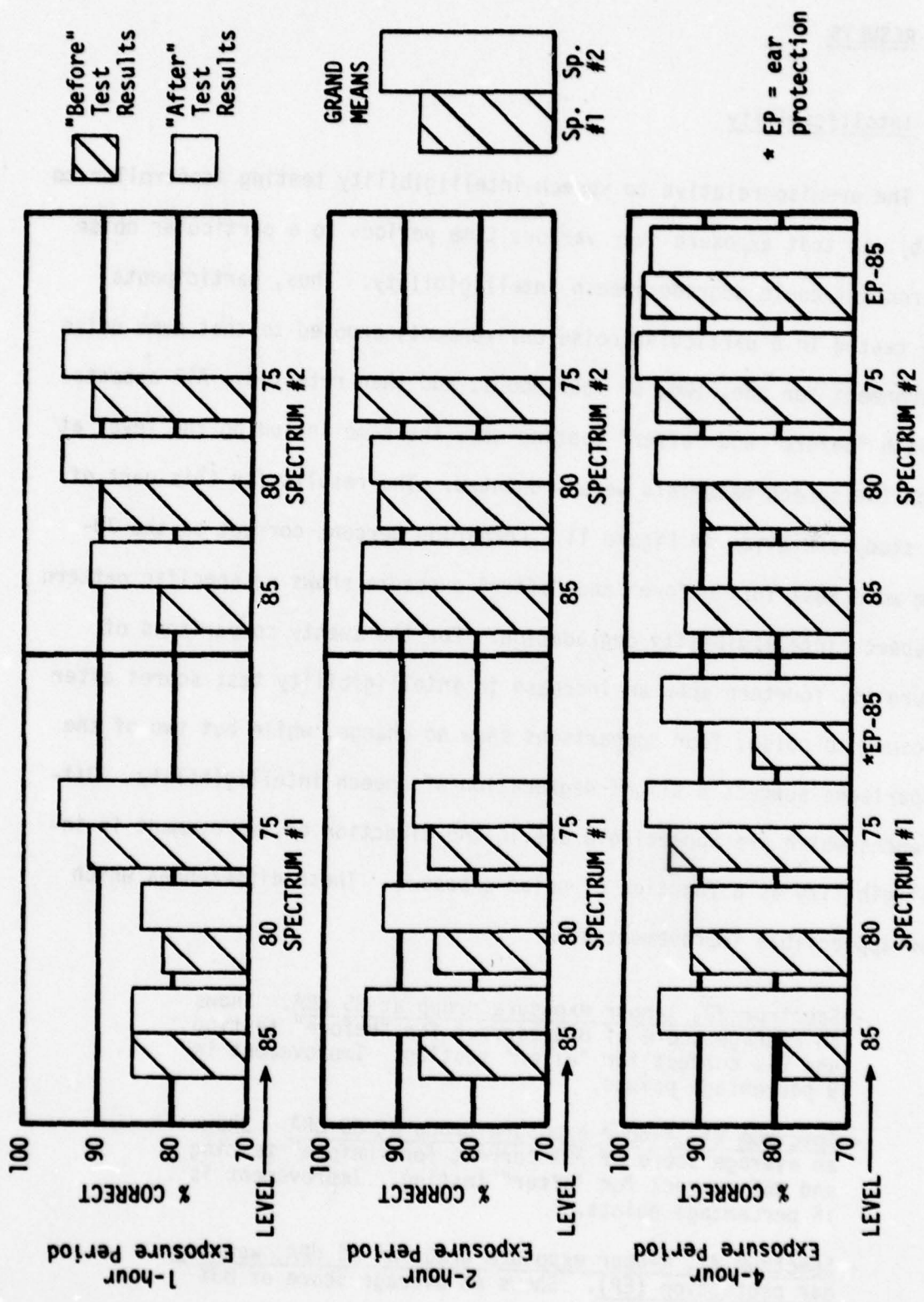

Figure 11. Percent correct for 70-item word test as a function of twenty noise conditions.

correct for "before" testing and 95% correct for "after" testing. Improvement is 13 percentage points.

That noise exposure does not result in degradation of intelligibility test performance but tends to be associated with improvement is also supported by the average difference across all groups between "before" and "after" test results. Average percent correct for "before" testing was 89% while it was 93% for "after" testing. The important conclusion from these results is that noise exposure at the levels investigated does not lead to degradation of speech intelligibility performance. In respect to the finding that some improvement did occur, it appears that there is some adaptation to the noise environments which results in this slight improvement. If adaptation is, in part, the explanation for this improvement, persons exposed for longer time periods should test at somewhat higher levels. Average percent correct on the 70-item test for spectrums 1 and 2 are plotted in Figure 12 as a function of exposure time. For spectrum 1, scores increase as exposure time to noise increases. For spectrum 2, percent correct is greater for the 2-hour and 4-hour exposure periods than for the 1-hour exposure period but there is a slight decrease in intelligibility scores for the 4-hour exposure period over the 2-hour period. In general, there is improvement with increased exposure durations, suggesting that adaptation to noise environments could lead to improved performance.

An additional consideration involves the expectation that higher noise levels could result in a decrease in speech intelligibility even though signal-to-noise ratios (5 to 10 dB depending on fit of earpiece) were similar at all levels. The average percent correct on the 70-item word test

for both spectra 1 and 2 as a function of the three exposure levels are given in Figure 13. For spectrum 2, speech intelligibility clearly decreases as noise level increases. For spectrum 1, there is a decrease in speech intelligibility as noise level is increased from 75 dBA to 80 or 85 dBA with intelligibility for 80 and 85 dBA exposure levels being almost identical. Higher noise exposure levels do result in decreased speech intelligibility but with identical signal-to-noise ratios for speech during all three exposure conditions.

Another comparison involves differences in results for the 57-item pre-experiment word test which was administered in a relatively quiet noise environment versus those obtained for the various noise exposure experimental conditions. Average percent correct for the 57-item pre-experiment word test and for each of the 10 experiment groups are given in Figure 14. A comparison of Figure 14 results with those of Figure 11 (results based on noise exposure conditions) shows that speech intelligibility in a relatively quiet noise environment is as good or better than speech intelligibility in a noisier environment. For the 57-item pre-experiment word test, average percent correct was 96.5 while it was 91.1% based on all experiment conditions.

A final consideration is concerned with the signal-to-noise ratio (speech level vs. environmental noise level) that was used. The speech level for all experiment conditions was the same as the exposure level under investigation. For example, if exposure level were 80 dBA, the speech level used was 80 dBA with signal-to-noise ratio being a function of the attenuation of the earpiece (5 to 10 dB depending on fit). After

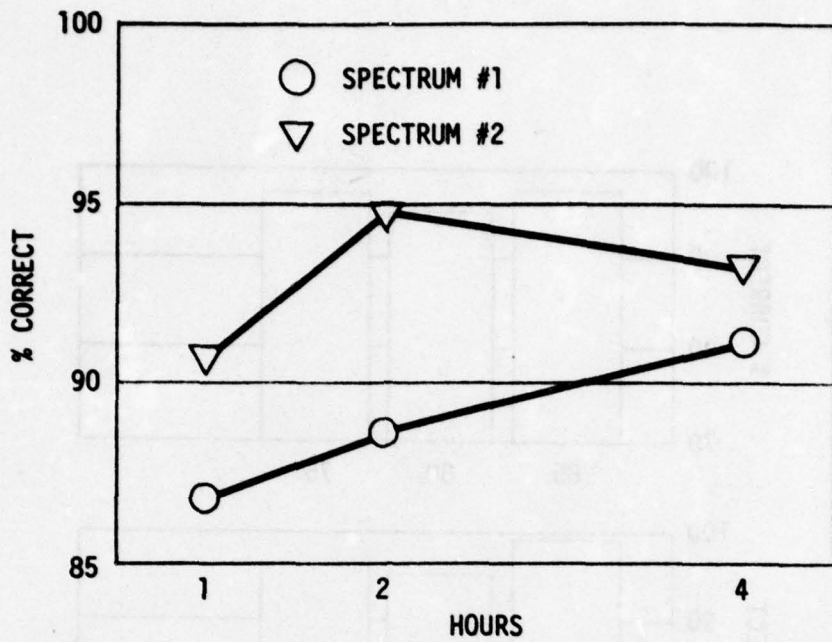

Figure 12. Average percent correct on 70-item word test for three exposure periods (Spectrums 1 & 2).

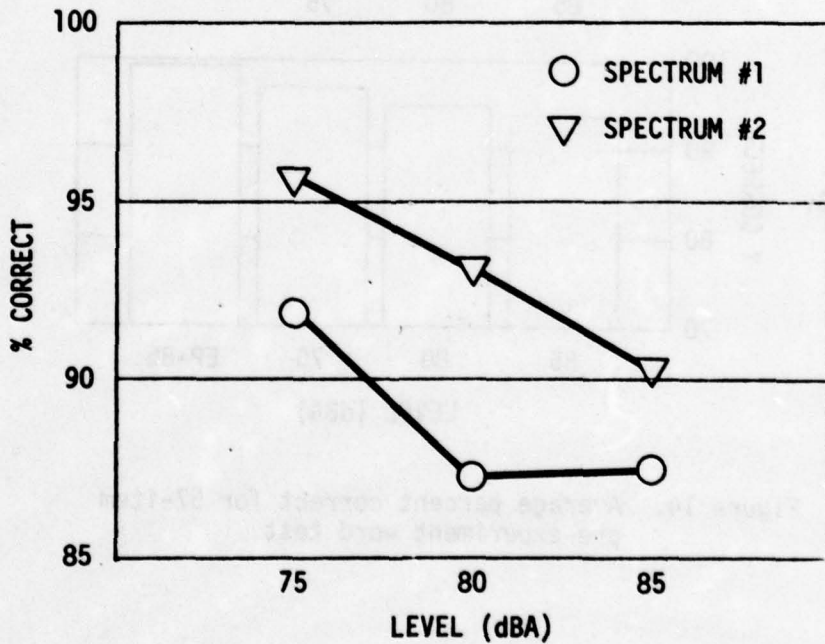

Figure 13. Average percent correct on 70-item word test for three levels (Spectrums 1 & 2).

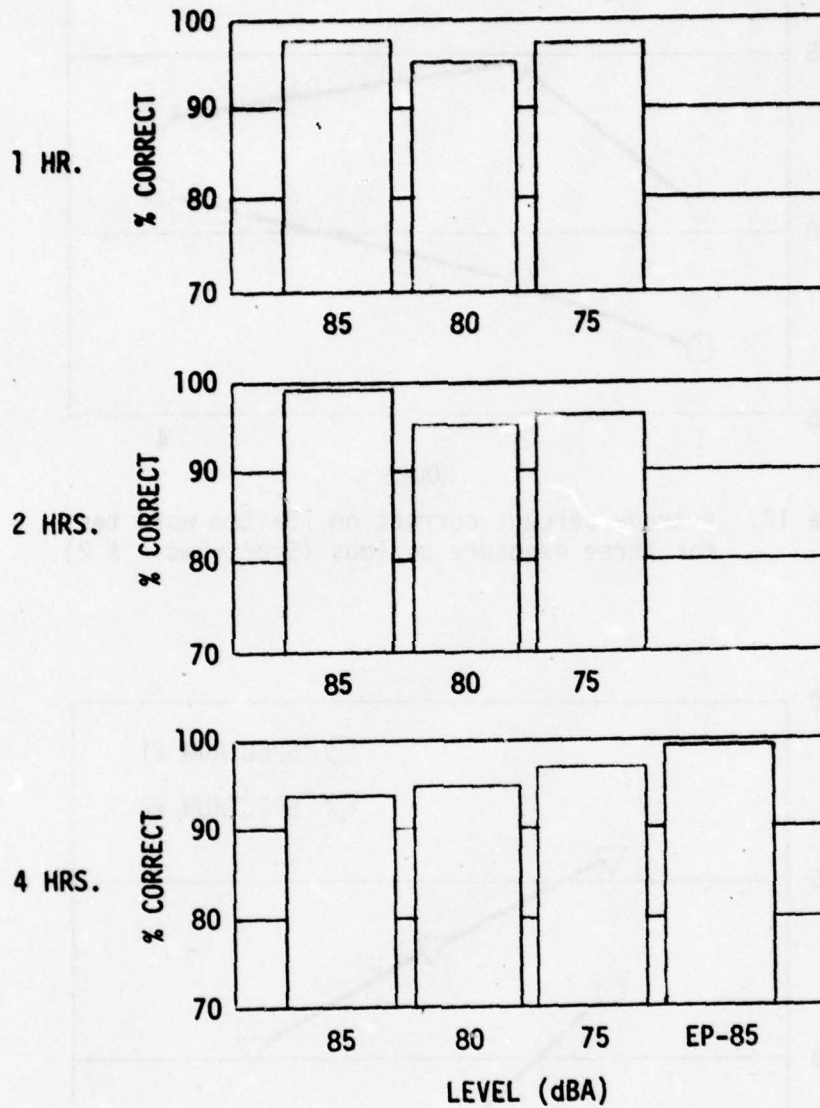

Figure 14. Average percent correct for 57-item pre-experiment word test.

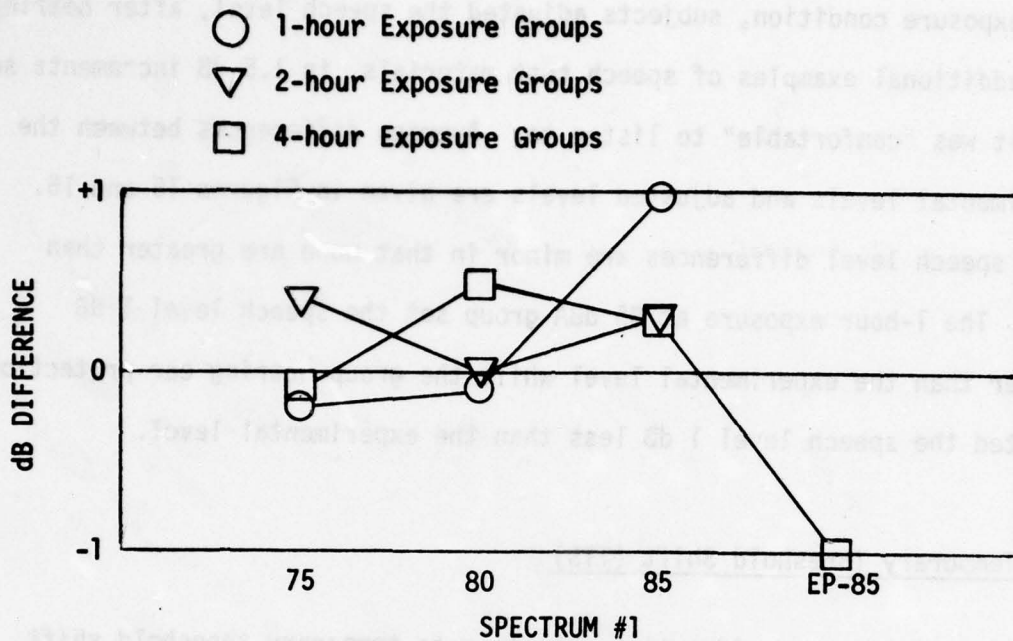

Figure 15. Average dB difference between experimental speech levels and levels adjusted for comfort (experiment less adjusted level).

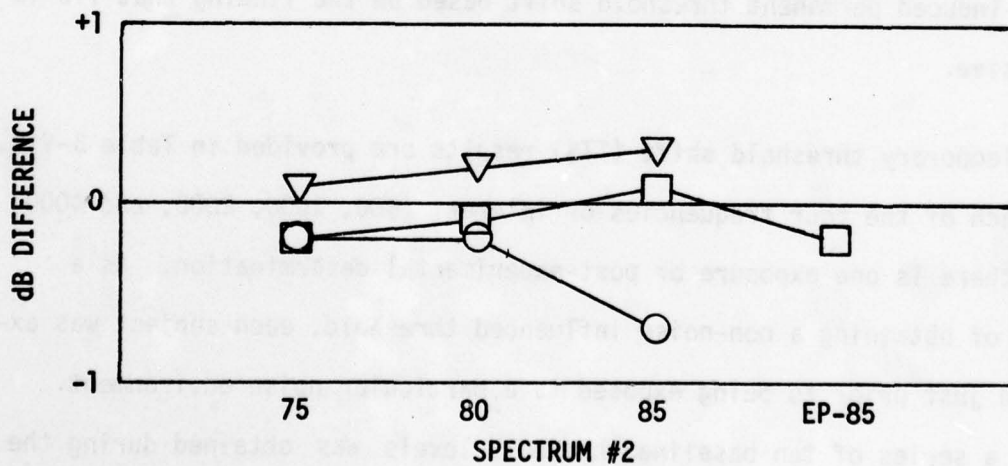

Figure 16. Average dB difference between experimental speech levels and levels adjusted for comfort (experimental less adjusted level).

each exposure condition, subjects adjusted the speech level, after hearing some additional examples of speech test materials, in 1.5 dB increments so that it was "comfortable" to listen to. Average differences between the experimental levels and adjusted levels are given in Figures 15 and 16. These speech level differences are minor in that none are greater than 1 dB. The 1-hour exposure at 85 dBA group set the speech level 1 dB greater than the experimental level while the group wearing ear protection adjusted the speech level 1 dB less than the experimental level.

### 3.2 Temporary Threshold Shift (TTS)

There are two considerations relative to temporary threshold shift (TTS) results. The first involves the expectation that increasing hearing thresholds in the speech frequency range could degrade speech intelligibility performance, while the second consideration involves prediction of noise-induced permanent threshold shift based on the finding that TTS is extensive.

Temporary threshold shift (TTS) results are provided in Table 3-VII. For each of the four frequencies of interest (500, 1000, 2000, and 4000 Hz), there is one exposure or post-experimental determination. As a means of obtaining a non-noise influenced threshold, each subject was examined just prior to being exposed to a particular noise environment. Also, a series of ten baseline threshold levels was obtained during the week just prior to the week of the exposure period. Thus, there are two threshold measurement sets to which noise-induced thresholds can be compared. Thresholds obtained just before a noise exposure period are called

Table 3-VII. Post-experimental less Pre-experimental, and Post-experimental less Baseline threshold differences (TTS) at 500, 1000, 2000, and 4000 Hz (average for both ears).

|                          | EXP. DUR.<br>(Hours) | SPECTRUM #1 |      |      |      | SPECTRUM #2 |      |      |      |
|--------------------------|----------------------|-------------|------|------|------|-------------|------|------|------|
|                          |                      | 500         | 1000 | 2000 | 4000 | 500         | 1000 | 2000 | 4000 |
| 75 dBA<br>Exposure Level | 1                    | *2.2        | 1.5  | 1.0  | 0.2  | 2.0         | -0.8 | 0.5  | 1.0  |
|                          |                      | 4.4         | 3.5  | 3.1  | 1.2  | 3.8         | 4.6  | 3.8  | 4.2  |
|                          | 2                    | 2.0         | 1.0  | 1.5  | 2.5  | 2.0         | -1.0 | 2.8  | 1.5  |
|                          |                      | 1.6         | 0.6  | 1.8  | 1.2  | 1.2         | -1.0 | 2.3  | -0.8 |
|                          | 4                    | 1.2         | 3.0  | 3.5  | 5.2  | 2.2         | 1.5  | 0.5  | -0.2 |
|                          |                      | 0.8         | 2.9  | 2.9  | 4.1  | 4.4         | 2.4  | 2.4  | 1.6  |
| 80 dBA<br>Exposure Level | 1                    | 2.8         | 0.0  | 2.2  | 0.2  | 0.8         | 1.2  | 2.8  | 0.5  |
|                          |                      | 1.2         | 2.1  | 4.2  | 2.1  | 2.6         | 4.4  | 5.7  | 3.0  |
|                          | 2                    | 1.8         | 4.8  | 0.2  | 2.2  | 2.2         | 3.8  | 1.8  | 0.8  |
|                          |                      | 2.0         | 3.2  | 0.0  | 0.8  | 1.0         | -2.4 | 0.0  | -2.2 |
|                          | 4                    | -0.8        | 1.0  | 2.5  | 1.8  | 2.0         | 3.0  | 1.5  | 0.8  |
|                          |                      | 0.4         | 0.8  | 2.4  | 1.3  | 2.0         | 2.4  | 1.4  | 0.3  |
| 85 dBA<br>Exposure Level | 1                    | 1.0         | 0.2  | 2.2  | 2.0  | 3.0         | 2.5  | 1.8  | 1.0  |
|                          |                      | -0.2        | -0.1 | 0.4  | -0.6 | 4.2         | 4.4  | 4.8  | 2.4  |
|                          | 2                    | 2.0         | 3.8  | 6.8  | 6.8  | 0.5         | 5.2  | 4.5  | 2.5  |
|                          |                      | 2.0         | 2.4  | 6.3  | 6.2  | 2.0         | 4.4  | 4.3  | 1.7  |
|                          | 4                    | 0.0         | 1.5  | 3.0  | 8.8  | 3.0         | 5.5  | 2.2  | 1.8  |
|                          |                      | -2.0        | 0.2  | 1.9  | 6.8  | 3.0         | 7.2  | 3.4  | 3.8  |
| +4 - EP                  | 0.5                  | 2.0         | 1.5  | -1.0 | -0.5 | 1.5         | 2.0  | -0.5 |      |
|                          | -0.9                 | -0.6        | 1.8  | -0.4 | -1.9 | 0.4         | 0.8  | 0.0  |      |

\* Upper value in cell is Post-experimental less pre-experimental.  
Lower value " " " Post-experimental " baseline.

+ Wore ear protection during 4-hour exposure period.

pre-experimental while the average threshold based on the ten threshold determinations prior to the experiment are referred to as baseline thresholds. The upper number in each cell of Table 3-VII is the post-experimental threshold less the pre-experimental threshold while the lower number in each cell is the same post-experimental threshold less the baseline threshold. Examination of Table 3-VII shows that few of the

noise exposure conditions resulted in appreciable TTS but that the results are relatively consistent with the various conditions of the experiment. Due to the fact that the range of repeated threshold measurements under presumed identical conditions is large (a range of 10 dB is not unusual, see Figures 3a & 3b), and that a TTS of 5 dB can be considered as a minimal threshold shift, only TTS's which are greater than 5 dB using both pre-experimental and baseline threshold determinations (both numbers in a cell must be greater than 5 dB) will be considered as having application significance.

Examination of Table 3-VII 75 dBA Exposure Level Results (Rows 1, 2, and 3 of Table 3-VII) shows that there is no appreciable TTS at any of the frequencies tested. The post-experimental less pre-experimental TTS at 4000 Hz based on 4 hours of exposure to spectrum #1 does show a TTS of 5.2 dB but this result is not supported by results based on the more stable series of baseline threshold measurements. At most, it can be concluded that there is a tendency to TTS at 4000 Hz but that it is of minor import.

Results for the 80 dBA Exposure Level are similar to those for the 75 dBA Exposure Level groups. There is no appreciable TTS at any of the frequencies tested. The group exposed for one hour to spectrum #2 noise did show a TTS of 5.7 dB at 2000 Hz based on the baseline threshold determinations but it was not confirmed by the pre-experimental threshold determinations or by any TTS determinations resulting from the 2- and 4-hour exposure periods.

Using the guideline that for TTS to be considered appreciable, it is to be greater than 5 dB utilizing both methods to determine TTS, four sets

of TTS determinations meet this guideline at the 85 dBA Exposure Level. For the 1-hour exposure period, no TTS determinations are at 5 dB or greater (row 7 of Table 3-VII). However, for two hours of exposure to the spectrum 1 noise, TTS is greater than 5 dB at both 2000 and 4000 Hz (row 8 of Table 3-VII). For four hours of exposure at 85 dBA, spectrum 1 noise also provides appreciable TTS at 4000 Hz. For spectrum 2, only exposure at 85 dBA for four hours results in appreciable TTS at 1000 Hz (row 9 of Table 3-VII). Thus it can be concluded that at 2 to 4 hours of exposure at 85 dBA, spectrum 1 exposure can result in appreciable TTS in the 2000 to 4000 Hz range, and that for four hours of exposure at 85 dBA, spectrum 2 exposure can also result in appreciable TTS at 1000 Hz. That spectrum 1 results in TTS in the 2000 - 4000 Hz range and spectrum 2 at 1000 Hz is consistent with the respective energy distributions for the two spectra (see Figures 4 and 5). As the results for the group wearing ear protection show (row 10 of Table 3-VII), any tendency towards temporary threshold shift (TTS) as a result of four hours of noise exposure at 85 dBA was completely eliminated by ear protection.

### 3.3. Noise Annoyance

At the termination of the session, each subject rated the whole noise session using the following five-point category scale (see Appendix B - INSTRUCTIONS):

- (1) Not at all annoying
- (2) A little annoying
- (3) Moderately annoying
- (4) Very much annoying
- (5) Almost intolerable

The five categories are assigned numerical values ranging from 1 to 5 with "1" representing "Not at all annoying" and "5" assigned to "Almost intolerable". The means of these category ratings for each of the ten groups are given in Figure 17. Mean results for the two spectra are presented individually and grand means (averaged over level and duration) are provided based on the two different spectra. Results based on the twenty individual group means (two spectra) do not disclose any particularly meaningful pattern. With the exception of the 4-hour exposure group who experienced spectrum "1" noise at 85 dBA, mean annoyance response ranged from "A Little annoying" to "Moderately annoying". The group who experienced spectrum 1 at 85 dBA for 4 hours did rate that experience as being somewhat greater than "Moderately annoying". Also, on the average, those experiencing noise exposure for but 1 hour tended to rate the experience more annoying than persons exposed to 2 or 4 hours. The grand means for spectrum 1 vs. spectrum 2 show that the wide-body aircraft interior noise (spectrum 2) is rated less annoying than the noise for older narrow-body jets with both noise environments being at identical dBA levels.

In Figure 18, results are combined so that various comparisons are available based on spectrum, duration of exposure, and noise level. Mean comparisons for the spectrum factor with each isolated by duration of exposure show that regardless of exposure duration, spectrum 1 exposure is rated more annoying than spectrum 2 exposure (Figure 18, a.). Grand mean results for exposure duration (Figure 18, b.) show that on the average exposure of 1 hour is rated as being more annoying than exposure of either 2 or 4 hours while there is little difference between annoyance ratings for the 2-hour vs. 4-hour sessions. If mean results are arranged by the

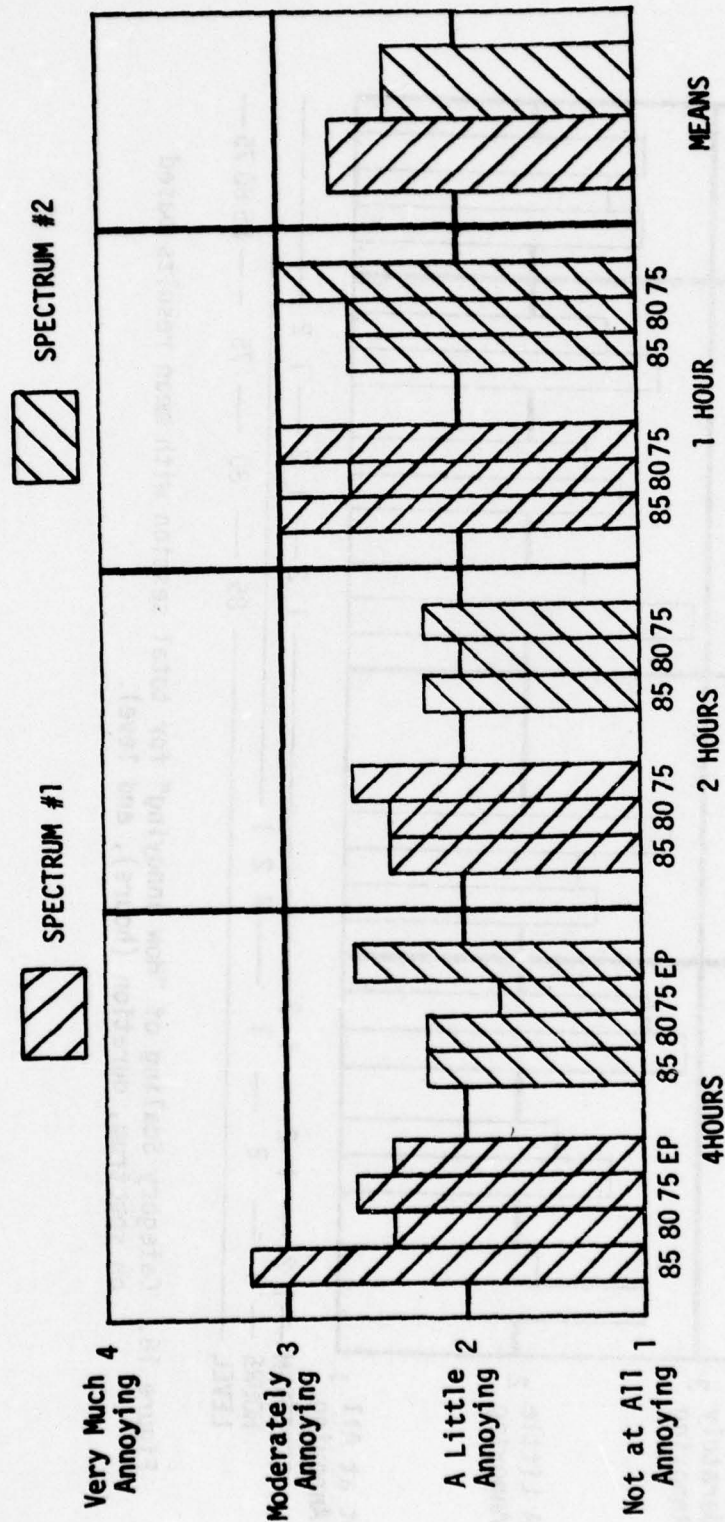

Figure 17. Mean Category Scaling of "How annoying" for total session.

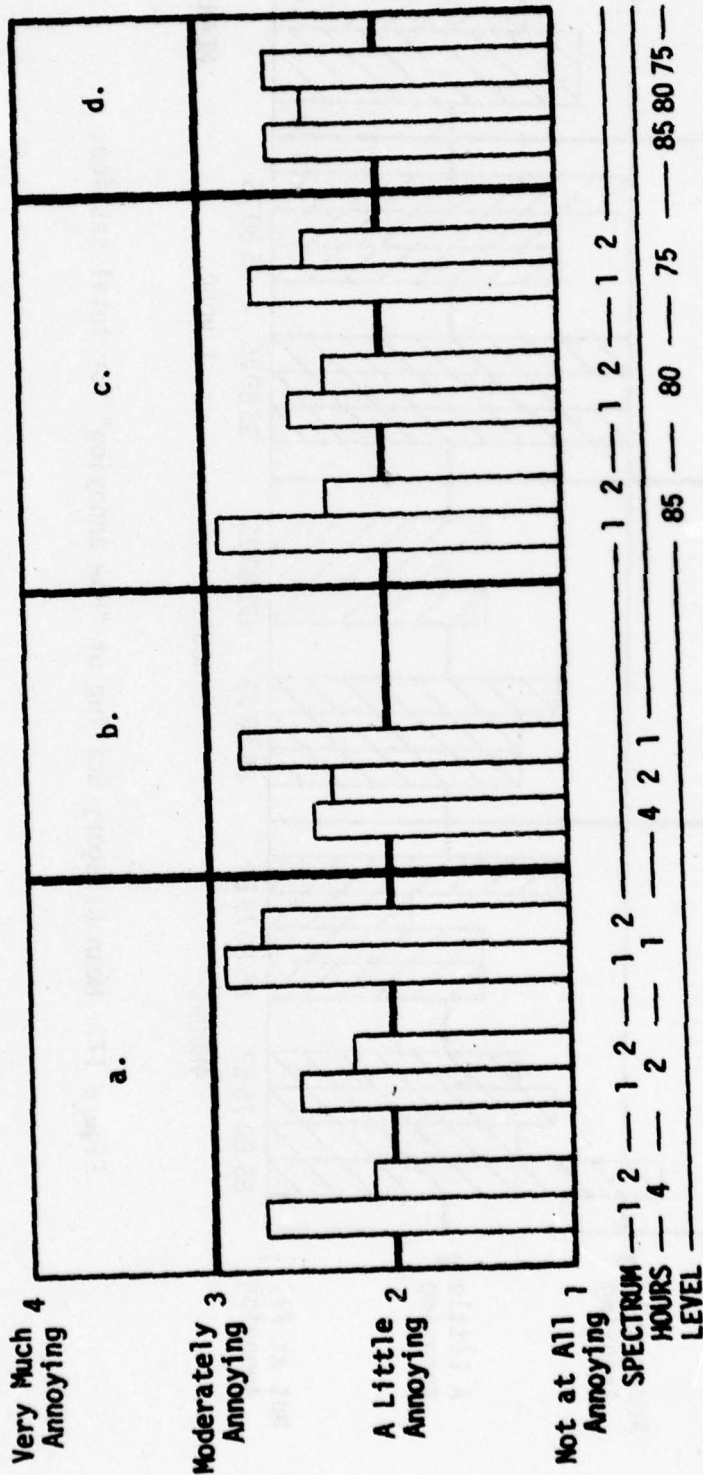

Figure 18. Category Scaling of "How annoying" for total session with mean results based on spectrum, duration (hours), and level.

spectrum and level factors (Figure 18,c.), regardless of level, spectrum 1 is rated more annoying than spectrum 2. Finally, grand means are provided based only on level (Figure 18,d.). The results show that there is no consistent relationship between the annoyance ratings and level. This is an anomaly in that it is expected that annoyance would increase with level and can possibly be explained by the fact that the three groups are composed of different persons; it may be that some personality or test response set variable is obscuring the expected relationship between annoyance response and noise level.

Results using this category scaling approach support two main conclusions which are:

- At identical dBA levels of exposure, noise for the narrow-body aircraft (spectrum 1) are rated as more annoying than noise exposure for the wide-body jet aircraft (spectrum 2).
- Since 1 hour of exposure is rated more annoying than either 2 or 4 hours of exposure, there is some evidence that adaptation to noise exposure conditions decreases annoyance response.

### 3.4 Magnitude Estimation

During each of the five training sessions, subjects were exposed to two minutes of broad band noise at 80 dBA which they were to use as a standard for magnitude estimation of the experimental sessions (see Appendix B - INSTRUCTIONS). Results for the two spectra as a function of exposure level are given in Figure 19. Using magnitude estimation ratings averaged over the three exposure durations for spectrum 1, shows that annoyance response does increase with level. However, rate of change for

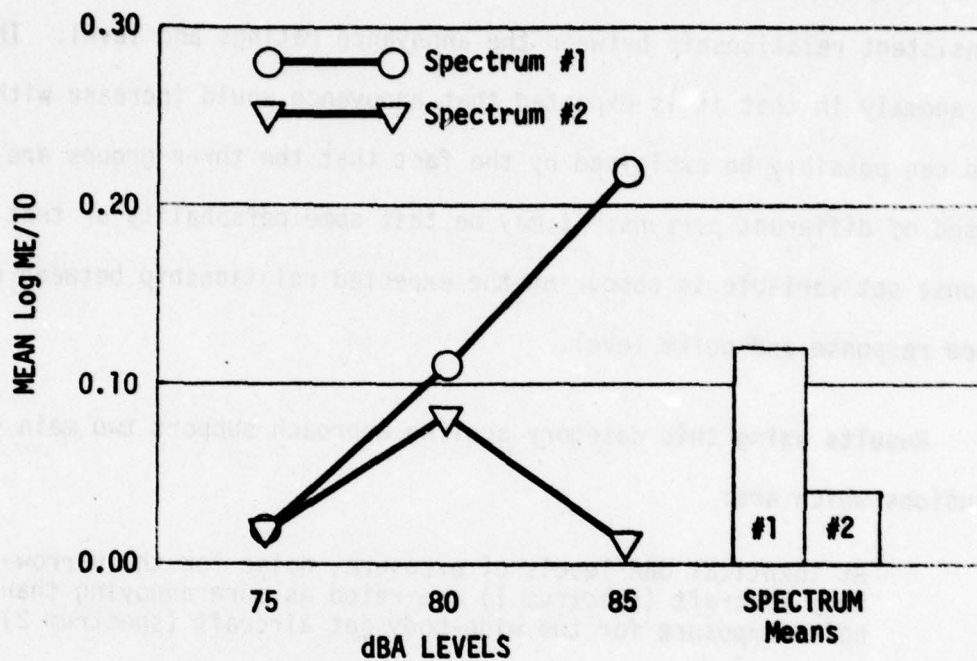

Figure 19. Magnitude estimation ratings as a function of exposure level.

doubling of noise annoyance is 15 dBA instead of 10 dBA which is often found for ratings of individual noise events. Ratings to spectrum 2 noise exposure are not as expected in that there is no consistent relationship between noise exposure level and the annoyance ratings. As for the category scaling ratings, these inconsistent results may be due to the fact that different groups of subjects are rating the three exposure levels. However, this does not explain why the different groups rated somewhat as expected to spectrum 1 noise exposure conditions and not to spectrum 2 (all 50 subjects were exposed to both spectrum 1 and 2 noise conditions). As for the category scaling results of the previous section, it is again clear that, on the average, the narrow-body aircraft noise (spectrum 1) is rated as more annoying than the wide-body noise if presented at identical dBA levels. A large proportion of average greater annoyance to spectrum 1 exposure is, however, contributed at 85 dBA.

### 3.5 Variability of Hearing Threshold Determinations and Manifest Anxiety

As shown by the results of Table 2-II and Figures 1 through 3, variability between and within persons when measuring hearing thresholds is relatively high. For example, range of measurements, depending on frequency, varied as much as 35 dB between persons with "normal" hearing (Table 2-II). For repeated measurements based on an individual subject's response, ranges of 10 to 15 dB for the ten baseline hearing threshold measurements were not unusual, particularly at the higher frequencies (Figures 1 through 3). It was hypothesized that a partial explanation of this variability in determining hearing thresholds is an indecisiveness or

uncertainty characteristic in individual respondents. As a method for testing this hypothesis, ranges of threshold determinations were correlated with scores on a test of Manifest Anxiety (Ref. 11). The rationale is that the Manifest Anxiety scores reflect a general personality characteristic of uncertainty and indecisiveness. Product-moment coefficients of correlation between ranges for the ten threshold determinations and Manifest Anxiety scores are given in Table 3-VIII. Of the fourteen coefficients of correlation, eight are significantly different from zero at the 5% level of confidence, while on a chance basis, not more than one would be significantly greater than zero. The results support the hypothesis that a kind of uncertainty or indecisiveness trait can partially explain repeated measurement differences when determining hearing thresholds.

Table 3-VIII. Product-moment coefficients of correlation for baseline audiometric ranges and manifest anxiety test scores (50 pairs at each Hz.).

| EAR   | HERTZ         |             |             |             |       |             |             |
|-------|---------------|-------------|-------------|-------------|-------|-------------|-------------|
|       | 250           | 500         | 1000        | 2000        | 4000  | 6000        | 8000        |
| Left  | <u>0.35</u>   | <u>0.26</u> | <u>0.33</u> | <u>0.40</u> | -0.01 | <u>0.30</u> | <u>0.24</u> |
| Right | * <u>0.25</u> | 0.04        | 0.22        | <u>0.29</u> | -0.11 | 0.12        | -0.09       |

\*— means that coefficient of correlation is not zero at the 5% level of confidence.

Another possibility is that there is a relationship between temporary threshold shift (TTS) and Manifest Anxiety test scores. This possibility was examined by correlating TTS results based on both post-experimental less pre-experimental TTS and post-experimental less baseline TTS for both spectra and both ears vs. Manifest Anxiety scores. This resulted in 32 correlation coefficients, each based on 45 pairs (persons wearing ear

protection were not included). Based on the results of Table 3-VII which shows some TTS at 2000 and 4000 Hz for spectrum 1 and at 1000 Hz for spectrum 2, it is expected that not more than twelve of the thirty-two coefficients would indicate actual positive relationships (there cannot be a significant correlation with no TTS). Table 3-IX gives the twelve correlations that could be significant based on the results of Table 3-VII.

Table 3-IX. Correlations between TTS and Manifest Anxiety scores that could be significantly different from zero.

| EAR   |                |         | HERTZ |       |       |       |
|-------|----------------|---------|-------|-------|-------|-------|
|       |                |         | 500   | 1000  | 2000  | 4000  |
| LEFT  | Post less Pre  | Spec. 1 | ----  | ----  | -0.17 | 0.23  |
|       |                | Spec. 2 | ----  | -0.14 | ----  | ----  |
|       | Post less Base | Spec. 1 | ----  | ----  | -0.08 | *0.25 |
|       |                | Spec. 2 | ----  | -0.27 | ----  | ----  |
| RIGHT | Post less Pre  | Spec. 1 | ----  | ----  | *0.31 | -0.04 |
|       |                | Spec. 2 | ----  | 0.06  | ----  | ----  |
|       | Post less Base | Spec. 1 | ----  | ----  | 0.23  | 0.09  |
|       |                | Spec. 2 | ----  | -0.07 | ----  | ----  |

\* Significant at 5% level of confidence.

None of the twenty correlations were significantly different from zero where no positive significant correlations were expected. As Table 3-IX shows, two of the twelve remaining coefficients are positive and significantly different from zero at a 5% level of confidence. Only results based on spectrum 1 exposure are involved. There is very slight evidence that TTS and Manifest Anxiety scores are related. However, the evidence is not at all firm and the positive relationship between these two measures is considered as being speculative at this juncture.

### 3.6 Engineering Calculation Procedure Considerations

The basic aim of an engineering calculation procedure which is designed to measure response to noise exposure situations, is to accurately or validly reflect person response. Do engineering calculation procedure measurements correspond with the various human response results? All response measures show that, at the same dBA level, spectrum 2 (wide-body) is preferred over spectrum 1 (narrow-body). For example, the grand mean intelligibility test results were 93% correct for spectrum 2 exposures and 89% correct for spectrum 1 exposures (see Figure 11). Subjects, on the average, rate spectrum 2 exposures less annoying than spectrum 1 exposures using both category scaling and magnitude estimation rating methods. Even the temporary threshold shift (TTS) measures showed less TTS (not as many frequencies involved) for spectrum 2 over spectrum 1. To accurately reflect these response results, a valid engineering calculation procedure must calculate spectrum 1 exposures at a higher level than spectrum 2 exposures. As shown in Tables 2-V and 2-VI, six engineering calculation procedures were applied to the two spectra. Differences between spectrum 1 less spectrum 2 calculations are given in Figure 20. For a calculation procedure to accurately reflect the human response results, the differences in Figure 20 should be positive and greater than 2 dB (see Ref. 12, pp. 61-65). Of the six calculation procedures evaluated, only the dBH difference (85.4 less 81.4 equals 4.0 dB) is positive and greater than 2 dB. Both dB(Flat) and preferred speech interference level (PSIL of Ref. 10) differences are negative or in a reverse direction with dB(Flat) in the wrong direction by over 5 dB. Both PNdB and SIL (Ref. 9) are in the correct direction but not to an extent that they

clearly measure differences between the two spectra.

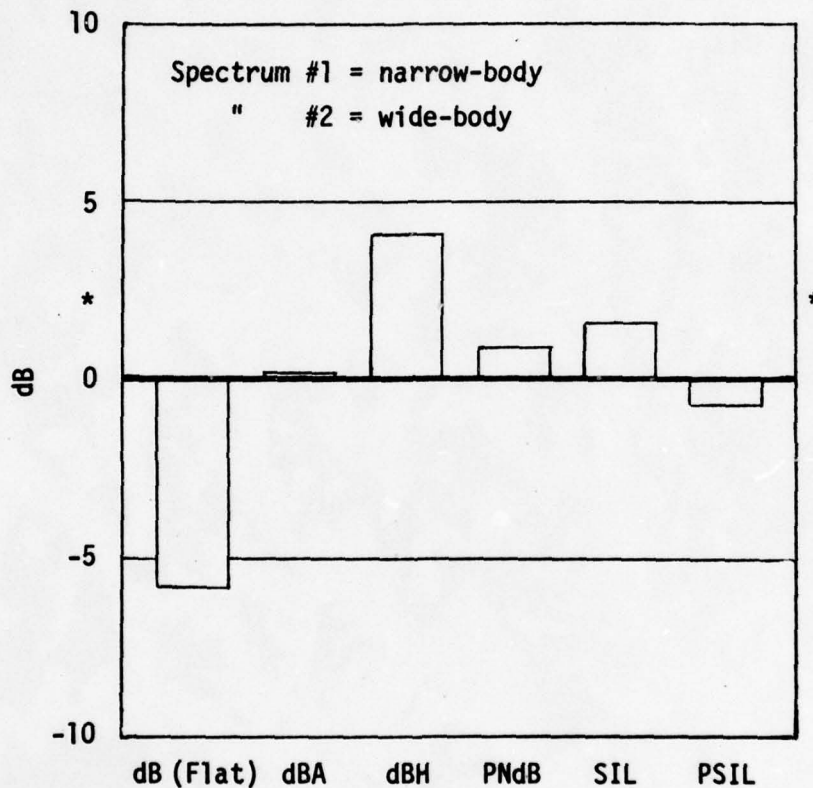

Figure 20. Engineering calculation procedure differences between the two spectra (Spectrum 1 less Spectrum 2).

\*For a calculation procedure to accurately reflect the human response results, the differences in Figure 20 should be positive and greater than 2 dB (see Ref. 12, pp. 61-65). Of the six calculation procedures evaluated, only the dBH difference (85.4 less 81.4 equals 4.0 dB) is positive and greater than 2 dB.

#### 4.0 DISCUSSION AND CONCLUSIONS

There is considerable controversy concerning noise exposure levels necessary to protect industrial populations from noise-induced permanent threshold shift (NIPTS). In dBA, limits proposed have ranged from 55 dB to protect 90% of the population from exceeding a 16 dB hearing threshold level fence averaged over 500, 1000, and 2000 Hz (Ref. 13), through 73 dB to protect 100% of the population from exceeding a 5 dB NIPTS at 4000 Hz (Ref. 14), to 80 dB to protect the median worker from incurring any NIPTS (Ref. 15). Flight deck crews not only require protection from NIPTS, but there is the additional consideration that these crews must perform critical tasks which are dependent on various communication modes (tower to pilot, engineer to pilot, etc.). Thus, workplace noise limits that may be appropriate for industrial workers in general may not be applicable to flight deck crews. These two interrelated requirements prompted the investigation of both temporary threshold shift (TTS) used as a predictor of NIPTS (Ref. 14), and speech intelligibility as a function of commercial jet aircraft flight deck noise exposure conditions. Conclusions for these two main requirements are:

- 1) It is concluded that a limit of 80 dBA is sufficient to protect flight deck crews from NIPTS.

This is based on the finding that no appreciable TTS was measured at 500, 1000, 2000, or 4000 Hz for exposure periods at 75 and 80 dBA. Depending on noise spectral characteristics, some TTS was measured at 85 dBA for a 4-hour exposure period but the magnitude of the average TTS measurements is not considered serious.

Temporary threshold shift (TTS) is completely eliminated at 85 dBA by a requirement to wear earplug protection.

- 2) Speech intelligibility performance is not degraded as a function of being exposed to noise environments comparable to flight deck noise conditions in commercial aircraft.

This conclusion is based on the finding that "after" exposure scores did not decrease when compared to speech intelligibility scores obtained "before" exposure but in the presence of the simulated flight deck noise environments. However, relatively higher noise levels with identical signal-to-noise ratios do result in some decrease in speech intelligibility. As level is increased (signal-to-noise ratios are constant), speech intelligibility tends to decrease. Also, with adequate signal-to-noise ratios for both situations, speech intelligibility is slightly superior in a relatively quiet noise environment when compared to results obtained in "noisy" (75 to 85 dBA) environments.

Thus, a third conclusion is derived which is:

- 3) It is concluded that it is advisable that flight deck noise levels in commercial jet aircraft be as low as is technically and economically possible.

Some additional conclusions are:

- a) Adaptation to noise levels does occur over relatively short periods of exposure time.

This conclusion is based on the findings that speech intelligibility scores tends to improve as exposure time is increased and that annoyance ratings are decreased as exposure time is increased.

- b) The flight deck noise spectrum representing the newer technology aircraft (high-bypass wide-body) is more desirable than that representing the older, narrow-body aircraft.

This conclusion is based on results which show that speech intelligibility is greater for the wide-body spectrum over the narrow-body spectrum and that at the same dBA level, the wide-body jet aircraft noise was found to be less annoying than the narrow-body jet aircraft noise.

- c) It is concluded that an uncertainty or indecisiveness personality trait partially explains repeated measurement differences when determining hearing thresholds.

The evidence for this conclusion comes from statistically significant positive correlations between range for repeated hearing threshold determinations vs. a measure of indecisiveness (Taylor's manifest anxiety scale, Ref. 11). The evidence is not strong since none of the significant product-moment coefficients of correlation account for more than 16% of the common variance.

- d) The traditional or institutionalized engineering calculation procedures such as dBA, PNdB, and PSIL do not adequately reflect the human response differences on the various dependent measures.

Of the six calculation procedures investigated, [dB(flat), dBA, dBH (Ref. 7), PNdB, SIL, and PSIL], only dBH adequately reflected the human response results (see Figure 20). Two calculation procedures which are often used to provide specifications for flight deck noise limits were the least effective. Both dB(flat) and

**PSIL measured the two spectra under investigation in the exact opposite direction from that of the subjects' response results.**

## REFERENCES

1. Browsher, J. M.; Johnson, D. R.; and Robinson, D. W.: "A further experiment on judging the noisiness of aircraft in flight." Acustica, Vol. 17, No. 5, 1966.
2. Taylor, J. A.: "The relationship of anxiety to the conditioned eyelid response." J. Exp. Psychology, 1951, 41, 81-92.
3. Stone, R. B.: "Cockpit noise environment of airline aircraft." Aerospace Medicine, Sept. 1969, 989-893.
4. Howlett, J. T.; Williams, L. H.; and Catherines, J. J.: "Measurement, analysis, and prediction of aircraft interior noise." AIAA Paper No. 76-551, Presented at 3rd AIAA Aero-Acoustics Conference, Palo Alto, CA, July 20-23, 1976.
5. Pickersgill, J. A., Aviation and Preventive Medicine Associates, Denver, CO, personal communication.
6. Ward, W. D.: "Studies of asymptotic TTS." AGARD Conference Proceedings No. 171 on Effects of Long Duration Noise Exposure on Hearing and Health, C4-1 to 5. Advisory Group for Aerospace Research & Development, 7 Rue Ancelle 92200, Neuilly sur Seine, France.
7. Higgins, T. H.: "Human response to sound: the calculation of perceived level, PLdB (noisiness or loudness) directly from physical measures." Report No. FAA-RD-76-1, November 1976.
8. Anon, FAR Part-36 Noise Standards: Aircraft Type Certification, Federal Aviation Administration.
9. Anon, ANSI S3.14, 1977 (average of 0.5, 1, 2, and 4 kHz).
10. Webster, J. C.: "SIL - Past, present, and future." Sound and Vibration, August 1969, p. 23.
11. Taylor, J. A.: "A personality scale of manifest anxiety." J. Abn. Soc. Psychol., 1953, 48, 285-90.
12. Mabry, J. E.; and Sullivan, B. M.: "Response to actual and simulated recordings of conventional takeoff and landing jet aircraft." NASA Contractor Report 145318, January 1978.
13. Kryter, K. D.: "Impairment to hearing from exposure to noise." J. Acoust. Soc. Am., 53, 1211-1234, 1973.
14. Anon, "Information on levels of environmental noise requisite to

**REFERENCES (cont'd)**

protect public health and welfare with an adequate margin of safety."  
U. S. EPA, No. 550/9-74-004, 1974.

15. Ward, W. D.: "Acoustic trauma and noise-induced hearing loss."  
The Nervous System, Vol. 3, Human Communication and Its Disorders,  
D. B. Tower, Ed., Raven, New York, NY, 1975.

APPENDIX A - Instructions for Use of Earplugs

USE OF EARPLUGS

You will be required to wear earplugs during your experimental sessions. After completing your pre-session audiogram, please put one plug in your left ear.

Then you will be asked to enter the test room where, as explained on the Instruction Sheet, you will be asked to put on the headset and complete a communications task.

When you have finished, please remove the headset and insert the other earplug. Continue wearing the plugs throughout the experimental session.

About 10 minutes before the end of the session, as explained on the Instruction Sheet, you will be asked to complete another communications task. For this, remove the plug in your right ear and put on the headset again.

When the experimenter takes you from the test room, please remove the plug from your left ear before doing the final audiogram.

## APPENDIX B - General Instructions

When you first enter the test room, please put on the headset and the experimenter will check its fit. When you are ready, switch the switch on the control box to light the bulb. When the bulb goes out, the communications task will begin. Write down what you hear of the phrases and mark how confident you are that you heard correctly.

After 14 phrases, there will be a longer section of speech. During this, please adjust the volume control until the speech is at a level comfortable to listen to and as clear and understandable as you can make it. When you are satisfied, switch the control box switch again to light the bulb and note down your setting of the volume control. Then reset the control to 15.

Please remove the headset and take your seat. About 10 minutes before the end of your session, the control box light will light and the experimenter will ask you to put on the headset again. When you are ready, please switch the switch again.

Another communications task will begin; again write down what you hear and your confidence rating. After the 14 phrases, again adjust the volume control to a comfortable level. When you are satisfied, note the level, return the control setting to 15, and switch the light on.

### Magnitude Estimation

Next we would like you to rate the complete noise session you have just experienced. Rate it in relation to the standard sound you heard in the training sessions. Remember that the standard sound has a rating of 10. For example, if the session seems twice as annoying as the standard, you will write "20" in the space provided on the answer sheet. If it seems only one-half as annoying, write "5". If one-quarter as annoying, write "2-1/2"; if three times as annoying, write "30"; if

slightly more than twice as annoying, you may choose to write "21", "22", or "23", whatever is appropriate. If slightly less annoying, use the number that best expresses the difference, such as "7" or "8" and so on. Your own impression of the annoyance of the noise is what we want.

### Category Scaling

Finally, we would like you to rate the whole noise session using the following scale:

- (1) Not at all annoying
- (2) A little annoying
- (3) Moderately annoying
- (4) Very much annoying
- (5) Almost intolerable

Please write your ratings in the space provided on your answer sheet.

APPENDIX C - Tower-to-pilot Verbal Communication Materials

Special words used in Control-to-Pilot Communications:

|                |              |
|----------------|--------------|
| Airspeed       | Marker       |
| Altimeter      | N.D.B.       |
| Altitude       | Radar        |
| Approach       | Radial       |
| Back Course    | Runway       |
| Bearing        | Sidestep     |
| Ceiling        | Spacing      |
| Clear          | Speed        |
| Climb          | Squawk       |
| Departure      | TACAN        |
| Descend        | Taxiway      |
| Discretion     | T.C.A.       |
| D.M.E.         | Touch-down   |
| Flight Level   | Touch-and-go |
| Frequency      | Tower        |
| Front Course   | Traffic      |
| Glide Path     | Transponder  |
| Ground Control | Turbulence   |
| Heading        | U.H.F.       |
| Heavy          | Vector       |
| Hold           | Visibility   |
| Ident          | Visual       |
| I.L.S.         | V.F.R.       |
| Intercept      | V.H.F.       |
| Knots          | V.O.R        |
| Landing        | VORTAC       |
| Localizer      | Wake         |
| Maintain       |              |

## Typical Phraseology

### Weather Reports.

- "Visibility one five."
- "Altimeter three zero four zero."
- "Wind one four six at twelve."
- "Estimated ceiling three thousand broken, one zero thousand overcast." (altitudes in feet of two cloud layers)
- "Wind check one niner zero at eight."

### On the Ground.

- "Call the tower to cross." (permission to cross a runway)
- "Cross three four left and hold." (34L is a runway name)
- "Cross on the high speed." (taxiway names)
- "Cross on A seven." " " "
- "Taxi to the ramp, hold short. Traffic departing three four right, heavy jet."
- "Taxi to runway three four left; hold short of three four right."

### Take-off.

- "Climb and maintain one seven thousand." (climb to an altitude of 17,000 ft. and remain there.)
- "Contact departure." (contact departure control; may be followed by the radio frequency, eg. 178.9 MHz..."one seven eight point niner.")
- "Seattle departure control radar contact." (Seattle departure control has contact with the plane's transponder.)
- "Expect an altitude below T.C.A." (stand by for an order to fly at an altitude below the T.C.A.)
- "Radar service is terminated."
- "Radar contact lost."
- "Expect reidentification in fifteen miles."
- "Cleared for take-off one six left." (you have permission to take-off on runway 16L.)
- "Cleared, direct Sigma flight plan route to J.F.K." (you have been cleared to follow route Sigma direct to J.F.K. airport in New York.)

### Approach and Landing.

- "Descend to eight thousand."
- "Descend and maintain five thousand."
- "Descend and maintain flight level three niner zero."
- "Descend and maintain flight level above one eight zero."
- "Descend Victor one five seven." (V157 is a standard route.)
- "Maintain flight level one niner zero."
- "Maintain fifteen hundred feet to cross at Renton."
- "Maintain two thousand two hundred until you establish the localizer." (keep at an altitude of 2,200 ft. until you make contact with the localizer transmission.)

### Approach and Landing.

"Maintain fourteen hundred feet until the V.O.R."  
"Intercept the localizer."  
"Reduce your speed by thirty knots."  
"Reduce your speed to one eight zero."  
"Reduce your speed to one hundred and eighty knots."  
"Slightly below glidepath."  
"Well above glidepath."  
"Radar contact five southwest of Seattle." (the radar has made contact with you five miles S.W. of Seattle.)  
"Approach radar one three two point four." (the frequency of the approach radar is 132.4.)  
"Turn right ahead." (expect an order to turn right.)  
"Turn right heading one zero one."  
"Turn left heading zero one zero twelve miles from Redondo." (where Redondo is a geographical location.)  
"New York Ident."  
"I.L.S. one six right approach."  
"Clear to land two niner left."  
"Cleared for touch-and-go runway zero eight right."  
"Landing runway three four." (used to inform the pilot of the direction and runway in use for landing, eg. 340°, nearly northwards, rather than the opposite direction, 160°.)  
"How will you terminate your approach?" (using a visual or instrument landing?)  
"Use visual bay approach." (visual approach procedure over Elliot Bay.)  
"Expect a vector across the final approach course." (expect a heading order across the final course, instead of flying straight in...used in Seattle for noise abatement purposes.)  
"Fly a heading of zero niner zero to intercept vector two."  
"You'll be following that heavy jet at twelve o'clock and five miles below you."  
"I'm not getting your transponder."  
"Squawk code three alpha, two one zero five."  
"Join Ballard twotwentyone, radial inbound." (get onto the direction defined by bearing 221° from the location Ballard inbound to the airport.)  
"Cleared to V.O.R., one two left approach." (pilot has permission to land using a standard method, designated V.O.R. 12L.)

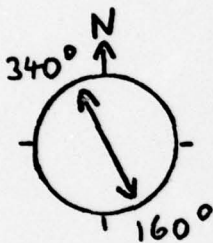

### Various times.

"Contact Seattle Center." (or "Kennedy Center", "tower", "ground-control," "departure," etc.) "one twenty one point seven" (change your present radio frequency to 121.7, and contact that control for the next part of your flight.)  
"Departure" ("Seattle Center," etc.) "will be one twenty-one point seven."  
"Call the tower"

Various times.

- "Turn right heading one three zero."
- "Traffic at twelve o'clock three miles northbound reading nineteen hundred unconfirmed." (there is another plane dead ahead of you at a distance of 3 miles and an estimated altitude of 1,900 ft., going northwards.)
- "Turn left fifteen degrees; the vector's around traffic."
- "Level at three thousand." (remain at your present altitude of 3,000 ft.)
- "Caution wake turbulence. Heavy DC-10 just departed three zero left."
- "Resume normal navigation." (giving navigational responsibility back to the pilot.)
- "Cross Cleveland at or above four thousand." (where Cleveland is the location of a navigation beacon.)
- "Your discretion two four zero." (the pilot can descend (or climb) to 24,000 ft. if he so wishes.)

## GLOSSARY

Affirmative - yes (used for emphasis)

Altitude - measured with an altimeter. For altitudes below 18,000 ft, given in thousands and hundreds ( or hundreds) of feet. E.g., "one thousand five hundred" means 1,500 ft, sometimes expressed as "fifteen hundred". "One three thousand" or "thirteen thousand" is 13,000 ft. For altitudes at or above 18,000 ft, "flight level" is used. This represents a barometric altimeter indication; for instance, "flight level two five zero" represents an indication of 25,000 ft. Three digits are always used, to represent hundreds of feet.

Approach - e.g., "initial a.", "final a." - components of a standard flight pattern used on approaching an airport. "Approach" does not include the final "touch-down" or "landing".

Back course - see localizer.

Bearing - (the horizontal direction to or from any point) magnetic compass direction. Given as three digits, e.g., "three six zero" (360° - north), "zero zero five" (5° - 5 degrees east of north). The same phrasing is used to describe headings and wind directions.

Caution wake turbulence - warning to beware of turbulence set up in the wake of another aircraft, usually a heavy jet.

Ceiling - a cloud base; level given in hundreds or thousands of feet, e.g., "eight thousand" (8000 ft), "one one thousand" (11000 ft), "two zero thousand" (20000 ft).

Climb - "ascend" is not used, to prevent confusion with "descend".

Discretion - the pilot is given the option to undertake a maneuver.

D.M.E. - distance measuring equipment.

Flight level - see altitude.

Frequency - radio frequencies are given as four or five digits, e.g., 127.8, 130.95. Usually spoken as "one two seven point eight", sometimes "one twenty seven eight" or "one two seven eight".

Front course - see localizer.

Glide path - part of the standard approach/landing flight path. Defined by radar in an I.L.S. A plane's position is described by "slightly" or "well" above (or below) the glidepath where necessary.

Heading - magnetic compass direction of flight. Used when instructing a pilot to change his flight direction horizontally. See bearing for spoken phrasing.

Heavy - a category of jet capable of large take-off weight, eg. Boeing 747's, DC-10's and some DC-8's.

Hold - do not proceed; used by ground control for planes on the airport. E.g. "position and hold" - get into position (for take-off) but wait until given clearance before proceeding; "cross 16 left and hold short of 16R" - you are cleared to cross the runway designated 16 left, but stop before crossing runway 16 right.

Ident - engage the Ident feature of the transponder.

I.L.S. - instrument landing system. Uses radar beacons to guide the plane in (as opposed to V.F.R.)

Intercept - meet, eg. "fly heading zero niner zero to intercept the glidepath" - fly on heading 090 until you meet the glidepath. "Intercept" on its own (as in "fly 180 at intercept") means "at the interception of the present flight direction with the localizer transmission."

Knots - nautical miles per hour.

Localizer - a transmitter, part of the I.L.S. which provides the pilot with course guidance to the runway centerline. The "front course" describes the area in front of the localizer, the "back course" that behind it. "Landing on the back course" requires a special procedure.

Marker - eg. "inner m.", "middle m.", "outer m." Beacons in the I.L.S. giving range information. E.g. the outer marker normally indicates the position where an aircraft on the I.L.S. glidepath will intercept the localizer course.

Negative - no (used for emphasis)

N.D.B. - non-directional beacon. Often used in conjunction with I.L.S.

Radial - a magnetic bearing extending from a V.O.R. (etc.) navigation facility.

Runway - magnetic compass heading of a runway is given with two digits, representing tens of degrees; eg. "three six" would be 360°, north. Where there are two parallel runways, they are separated by left (L) or right (R)...36L, 36R. Where there are three, by left (L), center (C), right (R)...36L, 36C, and 36R.

Sidestep - a visual maneuver. The I.L.S. is usually for one runway. If the plane is required to land on a parallel one, it approaches initially on the I.L.S. path and then must move over or "sidestep" to the parallel runway when close enough for visual control.

Spacing - techniques for controlling the separation of planes, eg. when approaching a busy airport.

Speed - given in knots, usually in three digits, eg. "two eight niner" is 289 knots.

Squawk - eg. "squawk" (or "squawk code") "two two one five" "low." Tells the pilot to activate the specific code (2215) on the aircraft transponder. "Low" indicates he should set for low, rather than normal, sensitivity.

TACAN - U.H.F. navigational facility giving omni-directional course and distance information.

T.C.A. - terminal control area; airspace within which all aircraft are subject to control.

Touch-and-go - a touch-down followed by an immediate take-off.

Taxiway - path used by planes on the ground (not used for take-off or landing).

Traffic - aircraft. E.g. "traffic at 1 o'clock 1 mile eastbound" warns a pilot that there is another plane in front of him and slightly to the right, at a distance of one mile and moving to the east.

Transponder - the airborne radar beacon receiver/transmitter, which automatically receives radio signals from the ground and replies with a pulse (that identifies the plane) to those signals received on the mode/frequency to which it is set. (See Squawk)

Turbulence - see Caution wake turbulence.

U.H.F. - ultra high frequency

Vector - a heading issued to an aircraft to provide navigational guidance.

Visibility - in weather reports, given in nautical miles, eg. "visibility one five" (15 n. miles).

Visual - see V.F.R.

V.F.R. - visual flight rules; to be used by planes not using I.L.S.

V.H.F. - very high frequency.

V.O.R. - V.H.F. omni-directional radio range. A ground-based electronic navigation aid.

VORTAC - combined V.O.R. and TACAN system

Wind - direction given as for bearing; speed given in knots. E.g. "wind one six zero at niner" means a nine-knot wind from a direction of 160°