

AD-A072 030

ECLECTECH ASSOCIATES INC NORTH STONINGTON CONN  
TRAINING ASSISTANCE TECHNOLOGY INVESTIGATION.(U)  
MAY 79 T J HAMMELL, H T MANNING, F M EWALT

F/G 5/9

N61339-77-C-0107

UNCLASSIFIED

NAVTRAEQUIPC-77-C-0107-1

NL

1 of 2

AD  
A072030



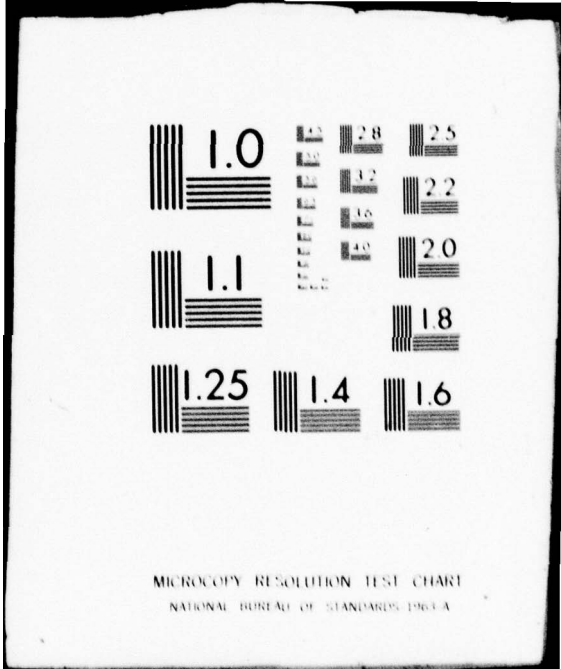

MICROCOPY RESOLUTION TEST CHART  
NATIONAL BUREAU OF STANDARDS-1963-A

**GOVERNMENT RIGHTS IN DATA STATE**

Reproduction of this publication  
whole or in part is permitted for  
purpose of the United States G

UNCLASSIFIED

SECURITY CLASSIFICATION OF THIS PAGE (When Data Entered)

REPORT DOCUMENTATION PAGE		READ INSTRUCTIONS BEFORE COMPLETING FORM
1. REPORT NUMBER NAVTRAEQUIPCEN 77-C-0107-1	2. GOVT ACCESSION NO.	3. RECIPIENT'S CATALOG NUMBER
4. TITLE (and Subtitle) Training Assistance Technology Investigation	9	5. TYPE OF REPORT & PERIOD COVERED Final Report, For period Jul 77 - Dec 78
7. AUTHOR(s) Thomas J. Hammell, Henry T. Manning Fred M. Ewalt	10	6. CONTRACT OR GRANT NUMBER(s) N61339-77-C-0107
9. PERFORMING ORGANIZATION NAME AND ADDRESS Eclectech Associates, Inc. P.O. Box 178 North Stonington, Connecticut		10. PROGRAM ELEMENT, PROJECT, TASK AREA & WORK UNIT NUMBERS Task 3751
11. CONTROLLING OFFICE NAME AND ADDRESS Naval Training Equipment Center Orlando, Florida	12	12. REPORT DATE 11 May 1979
14. MONITORING AGENCY NAME & ADDRESS (if different from Controlling Office) Defense Contract Administration Services Management Area, Hartford 96 Murphy Road Hartford, Connecticut 06114	176p.	13. NUMBER OF PAGES 181
16. DISTRIBUTION STATEMENT (of this Report) Approved for public release, distribution unlimited		15. SECURITY CLASS. (of this report) UNCLASSIFIED
	18	15a. DECLASSIFICATION/DOWNGRADING SCHEDULE
	17. DISTRIBUTION STATEMENT (of the abstract entered in Block 20, if different from Report) 19 77-C-0107-1	
18. SUPPLEMENTARY NOTES		
19. KEY WORDS (Continue on reverse side if necessary and identify by block number) Training Submarine Training Performance Measurement Submarine Tactics Training Technology Training Device		
20. ABSTRACT (Continue on reverse side if necessary and identify by block number) Advanced Training Assistance Technology (TAT) concepts have been developed to enhance simulator-base submarine tactics training. Many of these concepts have been implemented on a simulation of the MK 81 Weapon Control Console (WCC) to demonstrate their use during the training process. An empirical evaluation of the TAT capabilities in the operational submarine training context was deemed necessary to assess their effectiveness. This report addresses the initial phase of a multiphase effort to install TAT capabilities on a submarine combat systems trainer (SCST).		

DD FORM 1473 1 JAN 73

EDITION OF 1 NOV 65 IS OBSOLETE  
S/N 0102-014-6601

UNCLASSIFIED

SECURITY CLASSIFICATION OF THIS PAGE (When Data Entered)

390 940

down  
JOB

UNCLASSIFIED

SECURITY CLASSIFICATION OF THIS PAGE(When Data Entered)

and evaluate their effectiveness during a formal training source. This phase addressed the (1) selection of the trainer and course with which to conduct the evaluation; (2) formulation of the TAT training process segment; (3) development of training exercises; (4) development of performance measures; (5) identification of TAT model and display characteristics; (6) recommendation of the TAT/SCST interface methodology; and (7) development of a long-term research and development plan. An experimental evaluation of several TAT capabilities, using active submarine officers as subjects, was also conducted. This was accomplished in the laboratory using the MK 81 WCC simulation.

←

Accession For		<input checked="" type="checkbox"/>
NTIS GRA&I		<input type="checkbox"/>
DDC TAB		<input type="checkbox"/>
Unannounced		<input type="checkbox"/>
Justification		<input type="checkbox"/>
By _____		
Distribution/		
Availability Codes		
Dist	Avail and/or special	
<input checked="" type="checkbox"/>	<input type="checkbox"/>	

UNCLASSIFIED

SECURITY CLASSIFICATION OF THIS PAGE(When Data Entered)

PREFACE

The authors wish to acknowledge the assistance of several individuals who, together with their respective staffs, were instrumental in the conduct of this project. Their inputs spanned the project, including information collection, decisions, and the experimental evaluation of training assistance technology.

The Naval Submarine Training Center Pacific provided assistance regarding the Pacific force training and Submarine Combat System Trainers 21A38 and 21A40, in particular, regarding the interfacing of Training Assistance Technology. The authors would like to recognize the assistance of Captain John J. Hummer, USN, Commanding Officer, Naval Submarine Training Center Pacific (NAVSUBTRACENPAC), and his staff:

CDR Robert Harris, USN, Executive Officer, Pearl Harbor  
CDR Allen C. Johannesen, USN, Officer in Charge, San Diego Detachment

Continuous liaison, throughout the project, was established with the U. S. Naval Submarine School and Commander Submarine Group Two Staff. The submarine school staff worked closely with the authors, assisting in the investigation of the 21A37 Combat System Trainer, the 21B63 Generalized Individual Fire Control Trainer, and the various courses providing a variety of inputs. They, furthermore, acted as a review board for project outputs. Special thanks is extended to:

CDR Robert N. Charles, USN, Code 10, Director Advanced Tactics  
CDR James Carey, USN, Code 20, PCO/PXO Instructor  
LCDR Anthony A. Franzitta, USN, Code 24, Tactics Instructor  
LCDR Dennis Dykeman, USN, Code 24, Tactics Instructor

Submarine Group Two staff was the initial point of contact and greatly assisted in the formulation of the project. Additionally, they provided guidance regarding the relevant operational/training aspects of the problem, including suggestions that were translated into training feedback displays. Many of the experimental subjects were individuals from this group who graciously donated their free time. Special thanks is extended to Captain John D. Apple, USN, Assistant Chief of Staff, and additional Commander of Submarine Group-Two (COMSUBGROUP) staff members:

CDR Frank J. Cima, USN, Readiness and Training Officer  
CDR James M. Drustrup, USN, Commanding Officer, MK 48 TCP

Acknowledgement is also due Mr. Eric Maiser, Training Device Engineer, Naval Education and Training Systems, New London (NLON), Atlantic Area Representative. He assisted in the investigation of the 21A37 and 21B63 training devices.

TABLE OF CONTENTS

<u>Section</u>	<u>Page</u>
I INTRODUCTION .....	7
Background.....	7
Project Objectives .....	10
Empirical Investigation of TAT.....	10
Interaction with SMARTTS .....	10
II APPROACH .....	13
Training Process Formulation .....	13
Empirical Evaluation of TAT .....	17
III TRAINING PROCESS FORMULATION .....	19
Training Device and Course Selection .....	19
Training Process .....	25
Research and Development Plan .....	43
Modifications to the Training Model .....	45
IV EMPIRICAL INVESTIGATION OF TRAINING ASSISTANCE TECHNOLOGY .....	49
Introduction .....	49
Approach .....	50
Results .....	55
Discussion .....	60
Conclusions and Recommendations .....	65
V CONCLUSIONS AND RECOMMENDATIONS .....	67
REFERENCES .....	71
APPENDIX A (Description of Submarine Tactics Training Courses)....	73
APPENDIX B (Training Device Characteristics).....	77
APPENDIX C (Interface Discussion).....	79
APPENDIX D (Summary of Model Training Contents).....	101
APPENDIX E (Training Strategy Summary) .....	105
APPENDIX F (Training Exercises/Scenarios) .....	113
APPENDIX G (Training Displays) .....	153
APPENDIX H (Experimental Group Exercise Guide) .....	161
APPENDIX I (Control Group Exercise Guide).....	169
APPENDIX J (TAT Experimental Evaluation Scenarios).....	173
APPENDIX K (Trainee Input Characteristics).....	177
GLOSSARY.....	179

LIST OF ILLUSTRATIONS

<u>Figure</u>		<u>Page</u>
1	Recommended Training Assistance Technology Capabilities .....	9
2	Initial and Succeeding Course and Device Selections .....	14
3	SUBLANT/SUBSCOL Courses and Training Duties .....	21
4	Structure of the TAT Evaluation Segment .....	29
5	Performance Measure: Closing Rate.....	35
6	Performance Measure: Time to Station .....	36
7	Performance Measure: Solution Accuracy .....	38
8	Performance Measure: Probability of Counterdetection .....	39
9	Performance Measure: Quality of Approach .....	40
10	Flow Diagram of Investigative Structure .....	44
11	Schedule for the Establishment of Investigative Programs.....	47
12	Tactics Mode Display .....	51
13	Experimental Design Configuration Listing the IP Performance Scores for Subject and Exercise.....	58
14	Experimental and Control Groups Graphs .....	59
15	Mean IP Performance for TAT and Traditional Groups .....	61
16	Overall Mean Performance .....	62
C-1	Simplified Computer System Breakdown .....	80
C-2	PDP-11/35 System .....	82
C-3	AN/UYK-7 System .....	83
C-4	Executive Controls Execution of all Applications Modules .....	86
C-5	An AN/UYK-7 Core Load Map for 21A37/4 .....	87
C-6	Autonetics Interface .....	90
C-7	21A40 Performance Monitor .....	93
C-8	Second Approach System .....	95
C-9	Third Approach System .....	99
F-1	Typical Exercise Flow .....	114
G-1	Tactics Mode Display .....	154
G-2	TAT Alternatives Feedback Display .....	156
G-3	Multiple X,Y Graph Display.....	158
G-4	xDMh <sub>t</sub> Matching Display .....	159

NAVTRAEQUIPCEN 77-C-0107-1

LIST OF TABLES

<u>Table</u>		<u>Page</u>
1	Projected MK 81 Operational Installations .....	22
2	Secondary Performance Measures.....	41
3	Primary Performance Measures Used During Each Module .....	42
4	Research and Development Areas, Listed in the Order of Priority .....	46
5	Experimental Procedure .....	54
C-1	AN/UYK-7 Channel Assignments .....	84
C-2	Required Data Symbols, Locations, Type.....	97
K-1	Demographic Information (12 Subjects) .....	178

SECTION I  
INTRODUCTION

## BACKGROUND

Submarine tactics have continually evolved, undergoing unusually major changes in recent years. The almost procedural target motion analysis (TMA) techniques of the past (e.g., matching spots) have evolved into an extremely complex information processing problem, drawing raw data and processed information from a variety of sources. A variety of sophisticated TMA techniques are currently available (e.g., Kalman automatic sequential tracking (KAST)); each of these has a variety of associated processing capabilities (e.g., bearing editing). The sonar and fire control parties are becoming more closely integrated as a result of the importance of this coordination and the increasing degree of sonar information processing. Many of the recent substantial changes in tactics, and their underlying operations, can be traced to the deployment of new sonar, fire control, and weapon systems (e.g., AN/BQQ-5 sonar system, MK 113 MOD 10 fire control system, MK 48 torpedo). These more sophisticated hardware/software systems, introduced in the late 1960s, have paved the way for rapid evolutionary changes in tactical capabilities and operations.

The recently developed tactical system capabilities have placed new burdens on submarine personnel. The available data processing capabilities and complexity often require a higher level of individual and team skill to achieve the system's maximum tactical effectiveness than was required in the older systems. The operator's role is not reduced in the new systems. Rather, system potential has increased as a result of increases in hardware/software capabilities and operator capabilities. Greater skill is required at all levels, from the console operator (e.g., editing bearings on the MK 81 Weapon Control Console (WCC)), to the fire control coordinator (e.g., editing vast quantities of incoming historical data), to the approach officer (e.g., selecting MK 48 torpedo weapon setting parameters). The level of skill required is such that each position in the fire control and sonar parties should be manned only by a subject-matter expert.

The roles of training and training effectiveness have become increasingly important factors. The greater level of operator skill demands effective training as well as severe constraints on money and time to achieve those objectives. At a time when operational system developments point to the need for increased training time, submarine manning considerations have allowed less training time. For example, the 6-week Submarine Officer's Basic Course (SOBC) replaced the more comprehensive 6-month Submarine Officer's Indoctrination Course (SOIC) for those officers reporting to nuclear submarines. This change, which occurred in the late 1960s, has resulted in substantially less basic training, with greater emphasis on experience gained at sea. Conversely, the trend has been to use submarines less for at-sea exercises due to increased demands for their operational deployment. Hence, on-the-job (OJT) training has received greater emphasis. These factors point to the need for closely coordinated onboard and shore-based training. Furthermore, they necessitate a high yield in training effectiveness.

The existing submarine combat system trainers (SCSTs) lack fundamental technology that has the potential to greatly enhance the tactics training process (i.e.,

Hammell, Sroka, and Allen, 1971; Hammell, Gasteyer, and Pesch, 1973). The SCST has two general functions of equal importance. The first function is to simulate the tactical situation, including the own ship systems (e.g., MK 81 WCC displays reflecting own ship maneuvers), the environment, and the target. All of the simulators perform this function with a relatively high degree of sophistication. The second function of the training device is to provide assistance to the instructor and/or trainee and may consist of a variety of capabilities essential to training (e.g., generation and presentation of feedback information). Both functions, and their close integration, are crucial to an effective training process. Existing SCSTs have only minimal training assistance capabilities. They lack, for example, automated performance measures and detailed feedback display information which could greatly enhance the training process. Several of the more recent training device modifications (e.g., the 21A37 Device updating) have included additional training assistance capabilities. Nevertheless, substantial improvements in tactics training effectiveness may result from the addition of state-of-the-art training assistance technology.

Training assistance technology (TAT) capabilities have been recommended specifically for submarine tactics training (Hammell et al, 1971; Hammell et al, 1973) including: (1) diagnostic information display, (2) performance measures and standards, (3) analysis capabilities, (4) a knowledgeable opponent, and (5) alternative tactics investigation capabilities (see Figure 1). These capabilities, which are generally not operating on existing SCSTs, are fundamental to develop and conduct the training process.

Several investigations have demonstrated the feasibility of the TAT capabilities. A series of studies were initiated by the Naval Training Equipment Center (NAVTRAEQUIPCEN) to develop a prototype trainer with TAT capabilities and demonstrate their use (Pesch, Hammell, and Ewalt, 1974; Hammell, Pesch, Ewalt, and Rabe, 1976). The prototype trainer was configured around the MK 81 tactics mode display. A software model was developed to simulate submarine interactions on the MK 81 tactics mode display, with the supporting TAT capabilities. A variety of naval personnel have witnessed the operation of the prototype, both at NAVTRAEQUIPCEN and at Eclectech Associates' (EA) facilities, with favorable comments. Commander Submarine Training Center Pacific (SUBTRACENPAC) issued a letter to Chief of Naval Operations (OPNAV) OP-29 requesting the installation of TAT capabilities on the 21A40 Training Device in San Diego. This prompted an independent, limited investigation of TAT by the Naval Personnel Research and Development Center (NAVPERSRANDCEN) (Callan, Kelley, and Nicotra, 1978). They found strong support for TAT by the submarine crews undergoing training on the 21A40 Device, and measured an increase in training effectiveness as a result of TAT.

These investigations, although strongly supporting the TAT concepts, did not definitively demonstrate the effectiveness of TAT capabilities in submarine tactics training. TAT capabilities must be objectively evaluated to demonstrate their training effectiveness, and to provide the necessary impetus for their installation in the existing and future SCSTs. The cost of adding TAT capabilities should be relatively low to result in substantially improved training cost effectiveness. If TAT is accepted as a cost effective means of enhancing tactics training, the relative effectiveness of alternative TAT configurations needs to be determined. The TAT represents a variety of general capabilities, each of which may be used in different configurations. Characteristics of the information feedback display, for example, would depend on the specific training

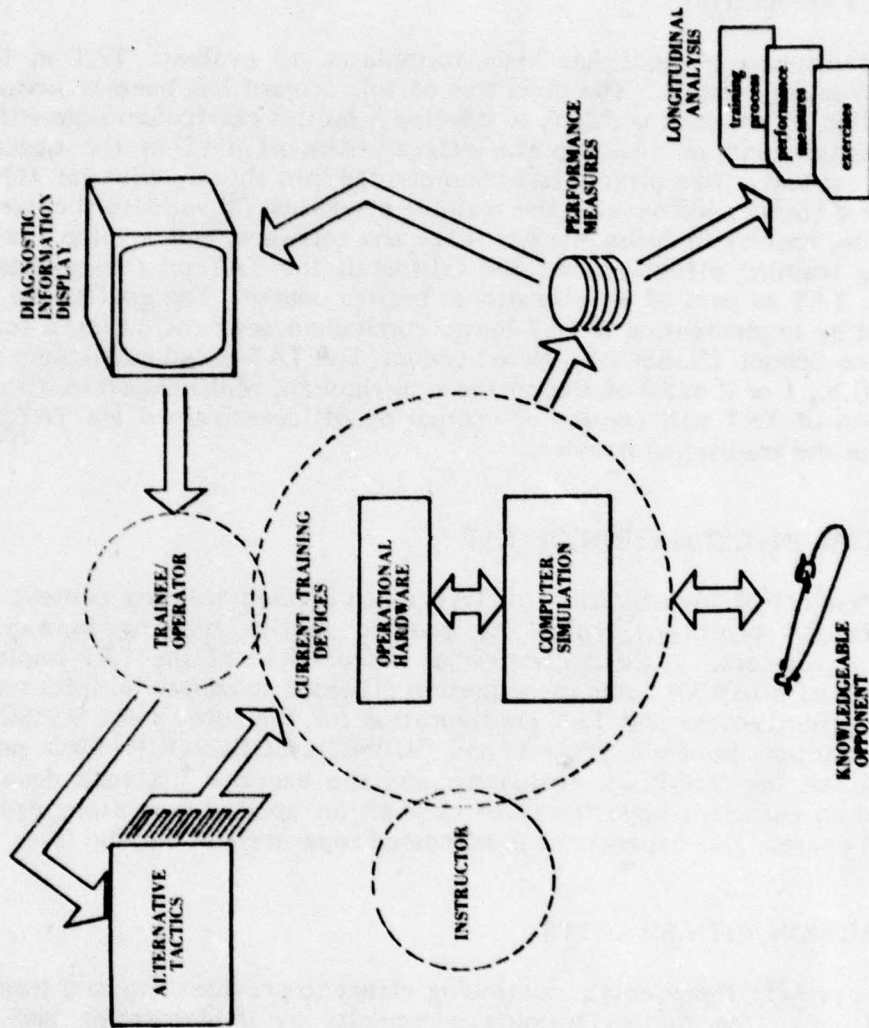

Figure 1. Recommended Training Assistance Technology Capabilities

## NAVTRAEQUIPCEN 77-C-0107-1

objectives, scenario contexts, performance measures, training strategy, and human perceptual characteristics. The TAT concepts have been developed and demonstrated in a limited context; they require further evaluation and development to achieve an effective configuration.

### PROJECT OBJECTIVES

A multiphase project has been formulated to evaluate TAT in the operational tactics training context. The objective of this project has been to install several TAT capabilities on an existing SCST, to develop a tactics curriculum segment using the TAT configuration, and to evaluate the effectiveness of TAT in the operational tactics training context. This project has been divided into three phases to: (1) select training device and course, and develop the training exercises; (2) validate the exercises via pilot evaluation, specify in detail the hardware and software, and develop a criterion test for assessing training effectiveness; and (3) install the TAT on the selected trainer, and evaluate TAT as part of an operational tactics course. The goal of the project will be achieved by implementing a TAT-based curriculum segment during a formal course at Submarine School (SUBSCOL), New London. The TAT-based curriculum will comprise a portion (i.e., 1 or 2 days) of the course's curriculum, replacing an existing portion. The evaluation of TAT will consist of comparing officers trained via TAT versus officers trained in the traditional manner.

### EMPIRICAL INVESTIGATION OF TAT

An empirical investigation of TAT in an applied training context was conducted using the EA prototype trainer to provide tactics training to experienced naval submarine officers. Although somewhat independent of the TAT implementation and evaluation of SUBSCOL, this investigation provided fundamental information pertaining to TAT effectiveness and TAT configuration for the subsequent SUBSCOL evaluation. The interaction between project and SUBSCOL/SUBGROUP TWO personnel during planning for the SUBSCOL evaluation and the exercise material development effort provided an excellent opportunity to conduct an applied laboratory experiment during the first phase. This experiment is addressed separately in Section IV.

### INTERACTION WITH SMARTTS

This project represents a continuing effort to provide advanced training technology capabilities to the tactics training community by implementing and evaluating the effectiveness of TAT in the operational submarine training context. The growth of the project stems from earlier requirements studies (e.g. Hammell et al, 1971; Hammell et al, 1973) and developmental efforts (e.g., Pesch et al, 1974; Hammell et al, 1976). It furthermore draws upon a variety of research and development efforts relevant to submarine tactics training (e.g., Sidorsky and Simoneau, 1970). Many of the TAT concepts formulated during the series of developmental efforts have resulted in the Submarine Advanced Reactive Tactical Training System (SMARTTS) program. By incorporating TAT capabilities, this program will upgrade existing SCSTs (e.g., 21A40). Considerable research and development is necessary to effectively use TAT; furthermore, the TAT capabilities should continuously evolve to increase the effectiveness of

tactics training. Results from the SUBSCOL implementation and evaluation should provide valuable information for the SMARTTS development.

The remainder of this report addresses the work accomplished during the first phase. This includes the developmental efforts for the experimental evaluation at SUBSCOL, and the applied experimental investigation of TAT in the EA laboratory.

SECTION II

APPROACH

The approach taken during this phase consisted of two distinct parts. Part A, training process formulation, dealt with (1) initial selection, installation, and evaluation of a tactics training device, and a course within which the TAT capabilities would be evaluated; (2) development and observation of the TAT training process, exercises, and their instructional approaches at SUBSCOL; (3) improvement of the training model to meet training objectives; (4) functional design of the TAT supporting hardware, software, and simulator interface to the 21A37 Device; and (5) formulation of a long-term research and development plan to support the further TAT development for tactics training. Part B consisted of an empirical evaluation of TAT in an applied submarine tactical training context, using submarine officers and a laboratory prototype simulator. Each part is addressed separately here and in subsequent sections of this report.

TRAINING PROCESS FORMULATION

The training process formulation was conducted by investigating current submarine tactics training, its needs, and the hardware/software characteristics of the training devices. This substantial information base helped to formulate the training exercises, interface design, and the long-term research and development plan.

**TRAINING DEVICE AND COURSE SELECTION.** An information base was developed pertaining to the various tactics training devices, training courses using those devices, and officer trainees. Particular attention was given to three devices for possible evaluation of TAT: (1) Device 21A37 SCST, New London; (2) Device 21A40 SCST, San Diego; and (3) Device 21B63 generalized individual fire control trainer, New London. Each of these was investigated with regard to the feasibility of implementing and evaluating a TAT-assisted training process in comparison with a traditional training process. The initial and succeeding selections, both course and device, are shown in Figure 2.

Collected information regarding a variety of aspects pertaining to the implementation and evaluation of TAT include:

- Training device characteristics, both hardware and software
- Training approaches used
- Training device use
- Training courses, their objectives and content
- Training device interfaces, their characteristics and cost
- Availability of tactical and related information to support TAT
- Officer trainee characteristics
- Potential effectiveness of TAT in the course

	INITIAL CONSIDERATION	FIRST ANALYSIS	FINAL ANALYSIS
COURSES	SOBC SOAC PCO PXO MK 113 Mod 10 Familiarization REFTRA PREDEPLOYMENT	SOAC or PXO or MK 113 Mod 10 Familiarization	SOAC  PXO
DEVICES	21A37 21B63 (21A40)	21B63	21A37

Figure 2. Initial and Succeeding Course and Device Selections

Training needs at each device

Information feedback, its content and use

Training support material, including training guides, training objectives, performance measures, and exercises

Projection of training device use

Course scheduling

The information base was assembled from (1) discussions with submarine operational and training personnel, (2) review of tactics training, instructional material, operational tactical doctrine, and training device literature, and (3) observation of training sessions on the tactics trainers.

Liaison was established with several submarine training and operational groups for information collection and review of developed materials. Extensive discussions with officers and enlisted personnel at SUBSCOL, and at SUBGROUP Two, New London covered all aspects of the problem, including observation of training sessions during several different courses using Device 21A37 and Device 21B63. Discussions were also held with tactics training personnel and training sessions were observed at the Submarine Training Center Pacific, at both the Pearl Harbor and San Diego detachments (representing Devices 21A38 and 21A40 respectively).

The information collected formed the basis for the selection of a tactics training device, tactics course, and a specific course segment, which in turn will form the context within which TAT will be evaluated. A set of tactical issues identified as potential high effectiveness areas were used to guide the selection of the TAT course and course segment. The TAT curriculum will be substituted for a specific segment within a current submarine officer training program; and will be evaluated by comparison with the traditional curriculum. The information generated from interfacing with the submarine community was instrumental in reaching these decisions. The collected information was also used in the development of the tactical training exercises, the evaluation and recommendation of TAT interface characteristics, and the development of the long-term research and development plan.

**TRAINING PROCESS AND EXERCISE DEVELOPMENT.** Specific tactics training objectives were developed for the TAT evaluation course segment. The training process strategy was developed to meet these objectives, using TAT capabilities. Tactics training exercises, including performance measures and information displays, were developed in accordance with the training process strategy. These elements formulated the training program for the evaluation of TAT.

The training process strategy formed the framework for the development of the training program elements (e.g., exercises). The strategy was formulated with regard to (1) applied considerations regarding the specific area of submarine tactics training, (2) tactics training objectives, (3) officer trainee characteristics, (4) capabilities and limitations of available TAT configurations, (5) availability of performance measurement algorithms, (6) acceptable training practices, and (7) device characteristics. Consideration for many of these factors also impacted the device and course selection,

as well as exercise development. The training process strategy is present in the guidelines developed for each exercise.

Several performance measures were developed for the tactics training objectives. These were individually developed with regard to specific tactical goals. Tactical operations often necessitate tradeoffs between conflicting goals; hence, a composite measure was also developed reflecting the overall tactical goal and responsive to tradeoffs in tactical actions. Algorithms for the performance measures were developed from current tactical doctrine and practices.

Information display formats represent important parts of the TAT configuration. The formats were developed for demonstration and feedback in accordance with the other training process elements as well as the presentation of the necessary information to the officer trainee with regard to training, modeling, and tactical considerations. The submarine tactical operations model was modified to generate the information necessary to support the displays.

A set of tactics training exercises structured in accordance with the training process strategy was developed to control the training program. These exercises address the objectives of the training program and contain the detailed information necessary to conduct it. Several scenarios were included in each exercise, along with instructor and trainee function information. The exercises were developed with regard to current tactical doctrine, using TAT capabilities to enhance the training process.

**TRAINING MODEL MODIFICATIONS.** The submarine tactical operations model was modified as necessary to support the training exercises. The modifications consisted of (1) implementation of performance measurement algorithms, (2) improvements of the MK 81 tactics mode display simulation, (3) development of additional TAT feedback displays, and (4) improvement of the functioning of current TAT capabilities. These developments resulted in a training process framework supported by a set of tactics training exercises. Performance measures, scenarios, and information displays were developed as part of the exercises.

**TAT INTERFACE.** The 21A37 and 21B63 Devices were investigated to determine the alternative methods of interfacing TAT capabilities. This effort was instrumental to the device selection process, generating information regarding the cost and feasibility of the various interface alternatives.

Several steps were involved in design and evaluation of interface alternatives. First, the characteristics of the 21A37 and 21B63 Devices were investigated to ascertain possible interface alternatives. This investigation yielded several alternative methods of generating the necessary TAT capabilities and interfacing to the training devices. It further yielded order of magnitude cost and difficulty estimates for TAT generation and interfacing, as well as other feasibility considerations. This information was generated from discussions with resident training device technicians and hardware and software documentation. The device selection for TAT evaluation was made on the basis of this information and other factors.

A more in-depth investigation of the hardware and software requirements was performed for interfacing TAT with the 21A37 Device. This included:

- a. Development of hardware and software functional system diagrams
- b. Development of a matrix detailing the characteristics and location within the system of parameters needed by TAT
- c. Identification of capabilities and limitations of relevant system components pertaining to TAT
- d. Identification of interface alternatives
- e. Development of a recommended functional interface design

This investigation was conducted by reviewing 21A37 Device documentation, discussions with training device technicians, and review of interfaces currently linking AN/UYK-7 and general purpose computers. In particular, the 21A37/PDP11/35 interface and the 21A40/TEKTRONICS 4051 interface were investigated and are fully discussed in Appendix C.

**LONG-TERM RESEARCH AND DEVELOPMENT PLAN.** A long-term plan was developed to identify pertinent research and to direct the development of training assistance technology. The research issues identified were based on the current gaps in knowledge pertaining to the implementation of TAT. A priority ranking of the areas and a recommended time schedule were assembled for the initiation of research into each area. A detailed investigative plan was developed for the highest priority area.

The plan was developed from:

- a. A search of the training technology literature
- b. Discussions with SUBSCOL and SUBGROUP TWO personnel
- c. Submarine tactics training observations
- d. Earlier studies in decision-making and tactics training, and
- e. Experience with TAT and submarine training needs

These sources provided the information from which the priority research areas were determined, based on (1) cost to investigate, (2) potential impact on training effectiveness, and (3) feasibility of conducting the research. The plan was intended to provide a guide from which investigation decisions could be made.

#### EMPIRICAL EVALUATION OF TAT

The training assistance technology as applied to submarine training was conducted and evaluated in a laboratory setting. This evaluation compared the effectiveness of a TAT training process with that of a traditional training process. A brief training

NAVTRAEQUIPCEN 77-C-0107-1

program was developed addressing a particular aspect of submarine tactical operations using qualified submarine officers as trainees in a TAT group and in a traditional group. The specific details of the approach and results are presented in Section IV.

The findings reported in the following two sections pertain to the efforts conducted during Phase I, Part A of the TAT implementation and evaluation plan. They consist of two distinct efforts: (1) the training process formulation for TAT evaluation in the SUBSCOL training context (Section III, Training Process Formulation), and (2) the empirical evaluation of TAT in the applied laboratory training context (Section IV, Empirical Evaluation of TAT).

SECTION III  
TRAINING PROCESS FORMULATION

The findings reported herein are developmental. They summarize the considerations, information collected, rationale, and the decisions made regarding how to implement TAT at SUBSCOL for an experimental evaluation. They further describe the developed TAT training process and exercises. In the selection of the training device, course, and course segment, the integration of the exercises, performance measures, and other TAT characteristics were considered to ensure a feasible and cost effective implementation of TAT. Hence, the efforts reported below overlap considerably.

TRAINING COURSE AND DEVICE SELECTION

The objective of TAT implementation in an ongoing submarine tactics training program is to evaluate the effectiveness of TAT compared with that of the traditional training approach under operational submarine tactics training conditions. Due to the lack of empirical information regarding the effectiveness of alternative TAT configurations (e.g., display design), it was imperative to select a training context for this initial implementation that had a high potential for enhancement via TAT. This important selection criterion impacted all aspects of the design of the TAT configuration as well as the conduct of the training itself. The second major criterion was the feasibility of implementing an investigatory program using an operational tactics training device and officer trainees. The alternatives for course and device selection, as well as interface design, were evaluated with regard to their impact, if any, on the ongoing tactics training program.

These two major criteria, combined with other criteria, yielded a set of considerations that were investigated pertaining to each course and device alternative. These were:

- Training need
- Training device exposure
- Training courses
- Potential impact of TAT on training and operational effectiveness
- Installation impact on the operational training schedule
- Installation cost
- Training methodology
- Evaluation control

The course and device selection were initially narrowed to those at the New London Submarine Base, because of the flexibility permitted by the variety of courses and devices, the availability of appropriate officer trainees, and logistic considerations. The submarine tactics training devices at other locations were also considered, particularly Device 21A40. However, the information compiled during the investigation reinforced the earlier decision to use either the 21A37 or 21B63 Devices. This decision was based on both the above-mentioned factors and others discussed later.

**COURSE SELECTION.** The New London Submarine Base is unique with regard to submarine officer training in that it has a formal submarine school as well as refresher courses and other training duties under SUBLANT (see Figure 3). This structure results in a large number of officer trainees at all levels of tactical expertise, and a high rate of device utilization. Two fundamental types of training are offered at New London, formal courses and refresher/predeployment training. The formal courses provide a standard curriculum for achieving specific training objectives. These include the general courses broadly spanning submarine operations (i.e., SOBC, SOAC, PXO, PCO), as well as specific courses addressing a narrow area of operations (e.g., MK 113 Mod 10 Familiarization Course). The refresher/predeployment courses may be standardized or unstandardized, depending on the needs of the particular group being trained. Five courses, selected on the basis of their potential for enhancement via TAT, were closely investigated: (1) Submarine Officers Advanced Course (SOAC), (2) Prospective Executive Officer's Course (PXO), (3) Prospective Commanding Officer's Course (PCO), (4) MK 113 Mod 10 Familiarization Course (FAM), and (5) REFTRA/Predeployment. Each of these courses deals with tactics training and may involve MK 81 WCC operation. The Submarine Officer's Basic Course (SOBC) was not considered because of its brevity in the tactics area. Furthermore, the operational context for TAT evaluation had been determined as comprising operation of the MK 81, which is not addressed during SOBC. Each of the selected courses is described in Appendix A.

Three of the five courses were selected for TAT implementation — SOAC, PXO, and MK 113 Mod 10 FAM based on similarities in areas and levels of tactics addressed and on the degree of flexibility possible for conducting experiments with the officer trainee population. None of the courses investigated currently address an intermediate level of tactics training regarding employment of the MK 81 WCC. This lack is primarily due to the current scarcity of operational MK 81 WCCs in the fleet and the resultant lack of demand for such training. Projected MK 81 WCC deployment on the East Coast, (Table 1) indicates a rapidly increasing demand for such training over the next 1 to 2 years. It is likely that each of these courses will similarly address MK 81 WCC use at an intermediate level within that period. An area of tactics training these courses are expected to address is that of TMA quality and approaching the target to a position of tactical advantage. These two issues were selected to represent the goals of the TAT training segment within each of the three courses. The training objectives developed with regard to these issues are addressed in greater detail later.

The selection of these courses has several advantages. The single training process developed to achieve the tactical goals should be applicable within each of the three courses. The TAT curriculum will partially fulfill a developing tactics training need, that of an intermediate/advanced level of instruction regarding MK 81 employment. Finally, a high degree of flexibility will be allowed in the final selection of officer trainees for the experiment. This selection can be responsive to training demand, scheduling, and the needs of SUBSCOL at the time of the empirical investigation.

Implicit in the above recommendation is the use of an intermediate level officer trainee. The basic level trainee is mostly concerned with rudimentary concepts. Although this level of training may benefit from TAT, it is less involved with applied tactical operations. Furthermore, basic tactics training today is generally accomplished in on-the-job training at sea. The SOBC course does not provide sufficient time for in-



TABLE I. PROJECTED MK 81 OPERATIONAL INSTALLATIONS

NLON AREA BOATS (ONLY)

1977

<u>FCS</u>	<u>NO. OF OPERATIONAL UNITS</u>
MK113/10	2 (8 to 12 T/Es per boat)
MK117	0
MPS	0

1978

<u>FCS</u>	<u>NO. OF OPERATIONAL UNITS</u>
MK113/10	3
MK117	1
MPS	4

1979

<u>FCS</u>	<u>NO. OF OPERATIONAL UNITS</u>
MK113/10	5
MK117	2
MPS	4

NORVA BOATS

1977

2 additional SSNs

1978

6 additional SSNs

1979

8 additional SSNs

depth tactics training. The intermediate level of tactics training will achieve the purpose of the experiment, and should best fit the design and implementation considerations.

The final course selection was further narrowed to the SOAC and PXO courses; the MK 113 Mod 10 FAM course was dismissed from consideration. This was the result of the device selection process, which is discussed below.

**DEVICE SELECTION.** The device selection process for the TAT evaluation, as noted earlier, focused on two tactics training devices at New London — the 21B63 and the 21A37. These devices differ substantially, although they both provide training in the MK 81 WCC context. The 21B63 provides individualized training centered about the MK 81 WCC. Its present configuration includes two MK 81 WCCs. The 21A37 provides team oriented training to the fire control party, consisting of 10 to 15 different positions. This device is configured for four independent attack centers, one of which simulates the MK 113 Mod 10 fire control system configuration.

These two devices fulfill different training needs in the selected courses. Fundamental MK 81 WCC tactical operations would be addressed using the 21B63 during each of the three courses. MK 81 WCC training is optionally given in the SOAC and PXO courses to those officer trainees that are assigned to a submarine having a MK 113 Mod 10 or MK 117 fire control system. Training on the 21A37/AC4 during the SOAC and PXO courses focuses on the broad issues of team tactical performance, during which some emphasis may be placed on fundamental operation of the MK 81 WCC and use of its generated information. The 21A37 would typically not be used during the MK 113 Mod 10 Familiarization Course. As noted above, the increase in MK 113 Mod 10 and MK 117 fire control systems is expected to cause both an increase in the demand for current training in the MK 81 WCC context, and for more advanced training in that context. Use of the 21B63 and 21A37 is expected to change in response to these evolving training needs. A more complete summary of these tactics training devices is contained in Appendix B.

Several important factors differ with regard to use of the 21A37 and 21B63. These are summarized below:

- The recent TAT developmental efforts have focused on individual training. The 21B63 provides individual training; the 21A37 provides team oriented training.
- The TAT evaluation experiment would be considerably more expensive and difficult to develop and conduct in a team context, as opposed to an individual context. The team context in comparison with the individual context would result in much less experimental control; require training exercises to address the team interaction as well as different individual positions; increase the difficulty of monitoring performance, providing feedback, and evaluating performance; and result in less powerful analyses.
- The potential effectiveness of TAT does not appear to differ between its use on the 21A37 and the 21B63.

NAVTRAEQUIPCEN 77-C-0107-1

- The 21A37/AC4 is extensively utilized. It is in demand during most tactics oriented courses. The 21B63 is not being used to its maximum potential. A review of records has indicated this device was used about 20 percent of its available time, based on a 40-hour week. The TAT hardware and software installation and the conduct of the TAT evaluation would have a greater adverse impact on the training programs using the 21A37. (The projected MK 81 WCC training demand (see Table 1), however, may alter this potential difference.)
- The current maximal benefits from the use of TAT are likely to occur in the 21A37 training context. This context has a greater need for the TAT capabilities due to the large number of simultaneously trained officers, and would provide the greatest exposure to TAT-based training. The projected increase in the number of student hours on the 21B63 over the next 2 years, although large, would be less than those on the 21A37/AC4 (i.e., including all courses and use).
- An intermediate to advanced level tactics curriculum is not available on the 21B63; it is available in the form of SOAC and PXO courses on the 21A37. The SOAC and PXO use of the 21B63 is very basic, generally limited to computer-assisted training (CAT). The TAT segment could be readily integrated into the existing SOAC and PXO curriculums using the 21A37; curricula addressing other areas of MK 81 WCC tactical operations would be necessary for the 21B63.
- Cost does not appear to be a primary factor in the selection of the 21A37 or the 21B63. An additional minicomputer display system would be the most feasible approach with the 21B63, requiring minimal software modification. Utilization of an existing minicomputer on the 21A37 is the recommended approach for interfacing TAT to that device (see Appendix C), necessitating somewhat more software modification than necessary for the 21B63. Hence, the expected respective hardware and software cost differences between the devices would be approximately equal.
- Intermediate to advanced tactics training has traditionally been centered around the FCC/AO/AO supervising the fire control party. Training at this level centered on a MK 81 WCC in an individual context (i.e., 21B63) may result in a low degree of officer trainee acceptance during the TAT evaluation.
- The SUBSCOL personnel that were involved in the project appear to prefer that the TAT evaluation be conducted on the 21A37. This is due to the currently greater need for TAT capabilities on that device (i.e., larger load on the instructor), and the greater use of that device to provide tactics training.
- Each of the three selected courses may use the 21B63. The MK 113 Mod 10 Familiarization Course does not use the 21A37.

As is evident from the above factors, a clear alternative is not available. Relative advantages and disadvantages are associated with each device. Furthermore, either device would be acceptable for the TAT evaluation, although each would require a different evaluative approach. Consideration of these factors by EA and

NAVTRAEQUIPCEN led to the decision to conduct the TAT evaluation on the 21A37. The small differences between many of the factors and the greater potential benefits to accrue from the TAT installation on the 21A37 weighed heavily in this decision.

The course and device selection process, therefore, recommended:

- a. The TAT tactics training segment should be developed for the SOAC and PXO courses. The curriculum segment should be selected such that one set of exercises could be used in either course.
- b. The TAT evaluation should be conducted on Device 21A37.

### TRAINING PROCESS

The TAT training process was developed in conjunction with the course/device selection process, and is tailored to the 21A37 Device. The developed training process consists of six elements: (1) the TAT evaluation approach, (2) tactical training objectives, (3) training course segment structure, (4) the TAT training exercises, (5) performance measures, and (6) TAT displays. An additional element, the traditional training exercises, may have to be developed to achieve the tactical training objectives. A tactics training curriculum based on the MK 81 WCC does not currently exist at the intermediate to advanced level. Training on this device, to date, has been primarily procedural. A curriculum which utilizes the MK 81's potential to provide information to aid the approach officer AO/FCC in the tactical decisions/recommendations (e.g., *geoplot maneuvering*) is not currently available as SUBSCOL training. If SUBSCOL has not developed this curriculum in sufficient time for the TAT evaluation, project personnel can develop it shortly prior to the evaluation period.

A discussion pertaining to development of each of the six elements follows.

**TAT EVALUATION APPROACH.** The TAT effectiveness evaluation approach will be based on a flexible structure within which TAT and traditional training processes can occur, rather than in a highly controlled experiment. Experimental conditions will generally consist of TAT and traditional training processes, with some variation allowed within each. A training segment has been selected for which exercises have been developed to support TAT-based training. The use of these exercises, however, will be left to the instructor's judgment, as will the use of the traditional training process. The characteristics of the officer trainee samples will likewise be free flowing. Data will be collected regarding the performance of all trainees and their use of the TAT capabilities. Biographical information will be collected from all trainees to permit a later breakdown of subject groupings. Finally, instructor and subject opinions will be collected regarding the TAT capabilities and their use. The intent is to conduct an open-ended experiment with minimal control, and to base the evaluation on observed use of TAT and performance.

The open-ended approach is necessitated by the nature of training provided on the 21A37 training device. The training is accomplished in a team context (i.e., the fire control party), often with emphasis on individual skills. A complex TAT configuration would be required to adequately address all of the fire control party positions within the

team context; this is beyond the scope of the TAT evaluation effort. Hence, a less structured experimental approach was selected.

This approach will provide additional benefits. First, the use of TAT will not be strictly constrained by the developed exercises; rather, it will be permitted to change during the evaluation period in correspondence with the perceived needs. These changes may occur regarding any elements of the training program (e.g., performance measures, scenarios, feedback displays). The changes should result in a more effective TAT training process. Secondly, the use, and hence evaluation of TAT will not be limited to the selected training course segment. Although this segment and its exercises are expected to comprise the predominant source of TAT evaluation information, information will be collected from other training course segments using TAT. It should be noted that the TAT capabilities installed on the 21A37 for the evaluation experiment will be made available during all training exercises on that device, to be used as desired by the instructors. Hence, considerable additional data may be available. Finally, a secondary purpose of this TAT evaluation experiment will be to compile developmental information regarding the design and use of particular TAT capabilities. The use of the alternative tactics capabilities, for example, will be monitored to determine the type and amount of use of particular characteristics, and their use relative to other capabilities. These benefits will directly assist the operational implementation of TAT, if proven effective.

A variety of data will be collected during the TAT evaluation period, primarily through automatic monitoring by the TAT subsystem. This information will include:

- a. Scenario setup and time-line data
- b. Trainee and instructor input/output during training
- c. Automated performance measures and other tactically relevant parameters
- d. Time frequency and type (e.g., commands and their sequence) of use for each TAT capability

Additional observation information will be collected from the instructor and trainees during and following each exercise. Finally, biographical information will be compiled from each trainee. These data will serve as the basis for TAT evaluations.

The evaluation approach will provide TAT developmental information in addition to a relative comparison with the traditional training process approach. The specific approach/experimental design will be developed in the next phase of this investigation.

**TACTICAL TRAINING OBJECTIVES.** Many tactical issues were investigated for use as training objectives. The bases of selection were:

- a. Commonality between SOAC and PXO courses
- b. Applicability of MK 81 WCC capabilities in assisting tactical performance
- c. Importance of, and current training need associated with, the tactical issues, yielding training need
- d. Absence of clear-cut tactical decision guidelines stemming from opposing tactical considerations, yielding training potential

- e. Availability of performance measures and operating guidelines
- f. The potential for training process enhancement as a result of TAT
- g. The training structure and process
- h. Officer trainee characteristics
- i. The potential for achieving the training objectives in a 1- to 2-day training segment

These considerations are responsive to the applied tactics training needs as well as the fundamental aspects of training and experimentation.

The predominant theme of the tactics portions of the SOAC and PXO courses is the tactical deployment/maneuvering of own ship in response to the tactical goals of the mission and particular situational factors (e.g., target(s) type and actions, environment, own ship configuration, and capabilities). This area of tactics (i.e., own ship deployment/maneuvering) is fundamental, representing a continuously evolving operational area, and hence an area of training need; is performed primarily by the approach officer with occasional assistance from the fire control coordinator and others; can effectively benefit from information derived via the MK 81 WCC (tactics mode display) and appears particularly amenable to the TAT information and capabilities developed on the experimental training simulation. Development of the tactical training objectives therefore focused on tactical deployment/maneuvering of own ship.

Deployment/maneuvering of own ship with regard to target motion analysis and closing the target to a position of tactical advantage were selected as the tactical issues to be addressed by the TAT training course segment. Of the many tactical issues pertaining to the deployment/maneuvering of own ship, these two appeared to best fit the considerations listed above. These two issues are fundamental to virtually all tactics training programs from basic to advanced levels. They are often present as simultaneous goals, calling for conflicting own ship maneuvers, and hence necessitating tradeoffs to achieve a near-optimum set of own ship maneuvers. Although procedures for specific situations are nonexistent due to the inherent complexity, guidance information does exist in the tactical doctrine. Furthermore, tactical parameters are available for information feedback and the development of performance measures.

A subset of these tactical issues was translated into the tactical training objectives:

- a. Recognize the effects of the mission objectives in constraining the values of closing rate, solution accuracy, and probability of counterdetection
- b. Recognize the impact potential own ship maneuvers have on probability of counterdetection (PCD), target bearing error (SNR), and bearing localization accuracy
- c. Understand the "optimum geometry" concept (optimum maneuver recommendations relative to solution accuracy, closing rate, and PCD tradeoffs)

These training objectives represent specific aspects of the two tactical issues. They pertain to the integration of different and often opposing own ship tactical functions to achieve a cohesive set of effective own ship maneuvers, thus optimally

attaining the tactical goals. They are currently addressed in the SOAC and PXO courses, although not in the context of the MK 81 WCC. They take into account the likely input characteristics of the officer trainees, the level of training, and the time limitations available for this particular segment of the training program. The officer trainees are assumed to possess an acceptable level of skill and knowledge regarding target motion analysis techniques and other tactical functions. The remaining elements of the training were developed with regard to achieving the training objectives.

**TRAINING COURSE SEGMENT STRUCTURE.** The TAT training course segment will comprise a part of the existing SOAC and PXO curriculum. It was developed to smoothly follow the preceding curriculum, and to serve as a transition to the succeeding parts. The training segment was thus developed as an independent unit to replace existing units.

The TAT training course segment, representing tactical training objectives, was selected from an investigation of SOAC and PXO training programs. The investigation progression and the relationship of the TAT segment within the SOAC/PXO structure is illustrated in Figure 4. The selection process is discussed below. It should be noted that the TAT-based training segment discussed below pertains only to the experimental group in the planned experiment. The control group will receive traditional training.

The SOAC training program on weapons employment tactics covers a wide range of tactical issues within four sections: (1) Basic Tactics Training, (2) Advanced Tactics Training, (3) Approach and Attack Training, and (4) Special Tactical Problems. The PXO training course has a similar structure for the weapon employment tactics portions, referencing the SOAC training materials. Furthermore, both SOAC and PXO courses use the same trainee evaluation guide during parts of their respective tactics training courses. The areas of commonality between SOAC and PXO, representing sections II through IV, were investigated closely with regard to the TAT evaluation.

The Approach and Attack Training section was selected for the TAT evaluation. This section, which is common to SOAC and PXO, covers three areas: (1) Anti-Surface Ship Approach, (2) Anti-Submarine Approach, and (3) Multiple Targets/Group Approach (basic, intermediate, and advanced). The training program addressing these areas includes both classroom and simulator training. The second area, Anti-Submarine Approach, was selected for the TAT evaluation. This area, which represents a 16-hour training course segment, addresses the anti-submarine approach and attack problem regarding MK 37 and MK 48 torpedo employment. The relevant tactical issues in this course segment have been the focus of past TAT developmental efforts, and are therefore appropriate for the TAT evaluation. The training in this segment is conducted predominantly in the attack center simulator, during exercises of varying length. It should be noted that the tactical concepts covered have been addressed during preceding classroom instruction sessions, in the basic and advanced tactics training sections. This segment represents the integrated simulator-based training portion illustrating and coordinating the tactical concepts.

A variety of tactical issues are addressed during the 16-hour training segment. These include: (1) management of the fire control party, (2) sensor utilization, (3) communication and coordination, (4) weapon launch procedures, (5) maneuvers for TMA

SOAC/PXO TRAINING COURSES

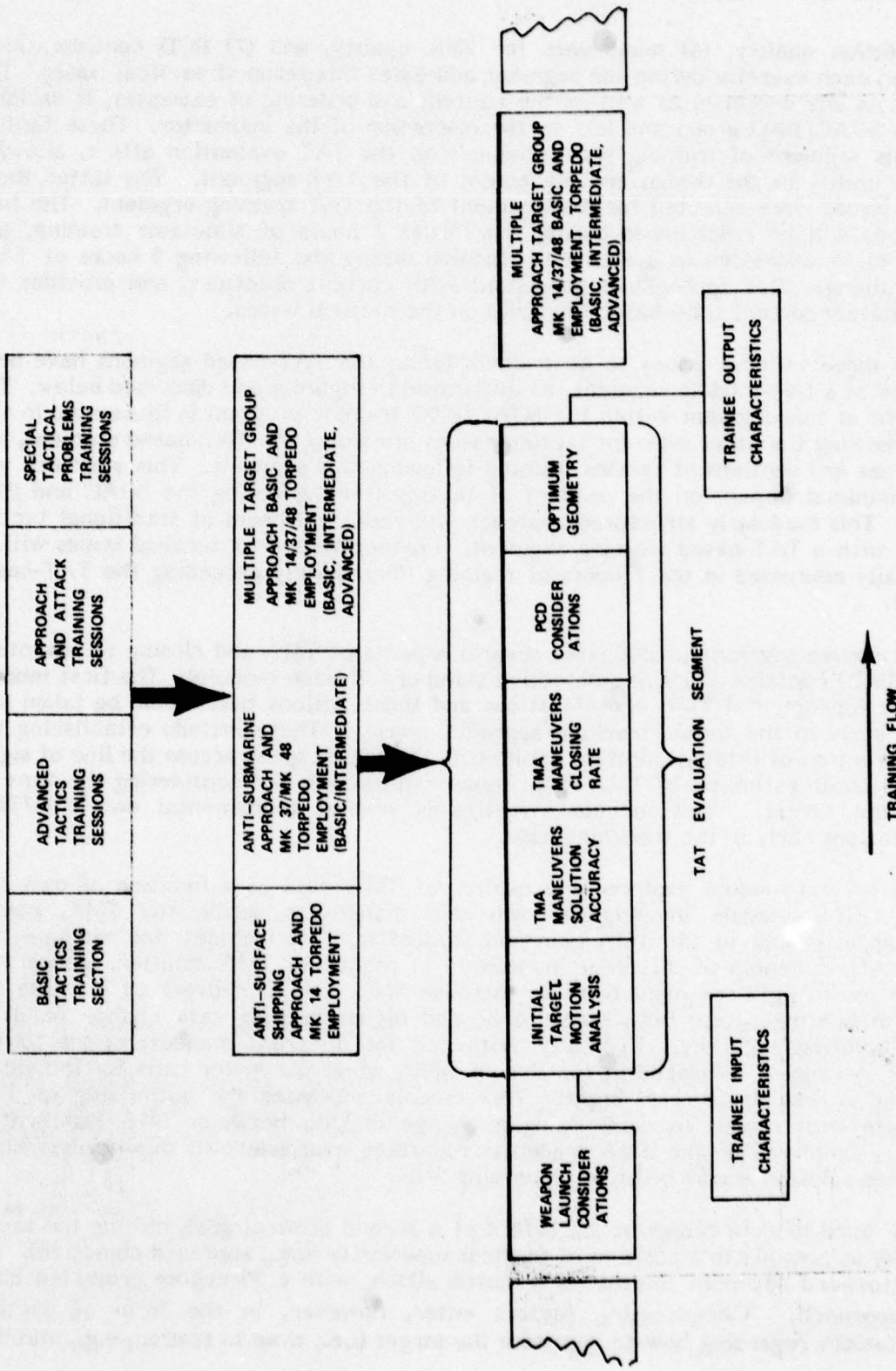

Figure 4. Structure of the TAT Evaluation Segment

TMA solution quality, (6) maneuvers for SNR quality, and (7) PCD considerations. Typically, each exercise during the segment addresses this group of tactical issues. The emphasis in any exercise, as well as the content and ordering of exercises, is variable for each SOAC/PXO group and left to the discretion of the instructor. These factors make this segment of training very amenable to the TAT evaluation effort, allowing some flexibility in the design and placement of the TAT segment. The latter three tactical issues were selected for development of the TAT training segment. The first four issues will be emphasized during the initial 7 hours of simulator training, and allowed to be addressed in a secondary fashion during the following 9 hours of TAT-based training. This approach is consistent with current practices, and provides the approximately correct time-based emphasis on the tactical issues.

The three tactical issues to be trained during the TAT-based segment have been addressed in a five-module segment, as illustrated in Figure 4 and discussed below. The placement of this segment within the SOAC/PXO training program is illustrated in this figure, showing the other relevant tactical issues preceding the TAT-based segment, and other areas and sections of tactics training following this segment. This approach will have a minimal impact on the conduct of tactics training during the SOAC and PXO courses. This modularly structured approach will replace 9 hours of traditional tactics training with a TAT-based training segment. Furthermore, four tactical issues will be specifically addressed in the 7 hours of training immediately preceding the TAT-based segment.

The course segment investigates several aspects of TMA and closing to advantage (Appendix D) contains a training objective summary of each module). The first module addresses fundamental TMA considerations and those actions that should be taken into account early in the target tracking/approach phases. These include establishing the target direction of relative motion, estimating the target speed across the line of sight, obtaining rough estimates of TMA (e.g., range estimation), and considering the time on leg of the target. This module investigates several fundamental own ship/TMA considerations early in the tracking phase.

The second module explores the quality of TMA data as a function of own ship actions. This module investigates own ship maneuvers during the TMA, paying particular attention to the TMA gain and tradeoffs. This includes, for example, the relative effectiveness of different maneuvers in regard to TMA solution accuracy; a tradeoff exists between maneuvers to increase SNR, and maneuvers to increase the change in bearing rate. Both higher SNR and higher bearing rate change result in greater solution accuracy. Typically, both call for different maneuvers; the former calls for increasing the speed in the line of sight, while the latter calls for increasing the speed across the line of sight. This module addresses the optimizing of TMA maneuvers with regard to maximizing a change in DBy between TMA legs with a secondary emphasis on the TMA tradeoffs regarding available own ship actions which maximizes solution accuracy while preserving SNR.

The third module brings in the effect of a second tactical goal, closing the target as rapidly as possible to a position of tactical superiority (e.g., approach objective). The straightforward optimum solution is a match xDMh<sub>t</sub> with a 90-degree projected track angle approach. Complicating factors enter, however, in the form of tactical considerations regarding how to approach the target (i.e., time to station, e.g., matched

xDMh, with projected track angles of less than 90 degrees). These factors are addressed.

The fourth module addresses the probability of counterdetection, one of several complicating factors that can affect the achievement of tactical goals. This factor may differentially affect the TMA and closing issues, depending on characteristics of the situation and specific tactical goals. This module investigates the contribution of PCD considerations in the selection of own ship maneuvers.

The fifth module addresses the major aspect of the problem, the integration of TMA and target approach considerations. Three tactical goals exist in this problem: to obtain the highest quality TMA solution as rapidly as possible; to maneuver to a position of tactical superiority as rapidly as possible; and to maintain probability of counterdetection at a low level. These goals were usually in conflict since the best TMA maneuvers (i.e., maximum changes in bearing rate) seldom result in the fastest closing rate (i.e., zero bearing rate). Faster closing rates may result in higher values of counterdetection. Hence, own ship maneuvers need to be chosen to achieve the best combination of these goals. This module addresses these tradeoffs in terms of the TMA gain associated with the available maneuvers (e.g., change in bearing rate, time on leg, the resultant closing rate, and the resultant PCD). An attempt is made to determine where the TMA gain begins to diminish (i.e., in terms of maneuver magnitude and time on leg), and where the average closing rate can be maintained relatively high.

These five modules form the structure of the tactics training course segment. Additional information regarding each is presented below in regard to the training exercises and performance measures.

**TRAINING EXERCISES.** The training process was designed to achieve the tactics training objectives as the result of a 9-hour training segment comprising five modules. Each module contains one or more training exercises, yielding a total of six exercises to encompass the segment. The exercises are directed toward the FCC/AO level, although they will be used in the team training context. The emphasis during the SOAC/PXO courses is typically placed on the FCC/AO positions, with the officer trainees rotating through those positions on successive scenarios. Hence, the exercises will be relevant to all the officer trainees during each scenario, even though they may be manning a variety of positions during any particular scenario.

The training course segment was developed to be completely conducted on the 21A37 Device. Lecture material was held to a minimum. This strategy is appropriate for the intermediate to advanced officer trainee level, since these personnel should already possess fundamental knowledge and skills and require only the integration of different facets of the problem. This integration is appropriately achieved in the context of the applied operational problem.

Other elements of the TAT training process include:

- a. Immediate and delayed feedback
- b. The use of a general purpose graphing display and a special purpose line-of-sight display to provide feedback and investigate the problem

## NAVTRAEQUIPCEN 77-C-0107-1

- c. The use of an alternative tactics capability to explore and contrast tactical actions
- d. Demonstration of relationships and tactical considerations using the operational and information feedback displays
- e. The use of several performance measures

The performance measures and feedback display capabilities are discussed in detail later. The training strategy is summarized in depth in Appendix E.

The training exercise guidelines were developed in accordance with the training strategy. They summarize each exercise in detail, including the scenarios, instructor, and trainee functions. The exercises were developed around four training techniques — positive guidance, immediate feedback (knowledge of results), delayed feedback (knowledge of results), and alternative tactics (knowledge of alternatives). Several exercises have been evaluated in the traditional training context at SUBSCOL. The investigations centered on the fidelity, difficulty, and appropriateness of the scenarios; and the adequacy and acceptability of the performance measures. The exercises and performance measures were modified slightly as a result of the evaluation. The detailed exercises are contained in Appendix F.

**PERFORMANCE MEASURES.** Several performance measures have been developed for the TAT training process. These include part-task measures directed toward specific aspects of performance, and a whole-task summary measure representing the integrated performance. The part-task measures will be used primarily for instruction in the form of investigatory feedback and analysis. The summary measure is necessary for evaluation of overall performance. Each of the measures represents a translation of tactical doctrine and practices into an algorithm. Furthermore, a variety of secondary performance measures have been identified. These are existing part-task measures that pertain to the relevant aspects of the tactical problem and/or an individual's function. They are addressed separately below. Two additional performance measures, information quality (I) and a summary measure (IP) representing performance on I and PCD (discussed below) were developed for use in the experimental evaluation. These measures (I, IP, and PCD) were developed expressly for use in the tactically less complex tradeoffs represented by the TCR experimental evaluation.

Five primary performance measures have been developed for the TAT training segment. They are:

- a. Closing rate (CR)
- b. Time to station (TS)
- c. Solution accuracy (SA)
- d. Probability of counterdetection (PCD)
- e. Quality of approach (QA)

Prior to discussion of each performance measure, several observations should be made relative to their development. These pertain to considerations of their use and further development.

The generation of a performance measure must be referenced to a particular situation, either actual or perceived. The submarine commanding officer does not know the actual situation at sea, only the situation perceived by the information available to him and his interpretation of it. Both the actual and perceived situations may be ascertained by the instructor during training, since he can monitor both sides of the problem. The question is, therefore, should the performance measures be based on the actual situation (e.g., the actual target actions) or the situation perceived by the officer trainee (e.g., based on the KAST solution information). The actual situation was selected as the basis, since it represents the more meaningful goal of the tactical encounter. Each of the performance measures was therefore based on the actual target geometry. Furthermore, a good KAST solution would be a natural consequence of the approach officer's efforts, if he performs well. It must be assumed that with a highly sophisticated device such as the MK 81 and KAST TMA procedures, a good KAST solution will develop if the AO performs the required ship control functions optimally. Additional performance-related information will be available during the exercises to enable the instructor to address the aspects of performance relative to the perceived situation, if he so desires. Additional factors, such as the rate at which KAST approaches an accurate solution could be factored in, if found necessary.

The complexity of tactical scenarios, often resulting in unpredictable own ship actions, precludes the use of rigid exercises. Rather, the exercises must provide a general framework around which the training process functions. A crucial aspect of this framework is the use of performance measures and other tactical information. A rigid structure guiding their use was rejected in favor of two capabilities:

- a. Random call-up of information by the instructor at any time in the training process
- b. Preplanned call-up at specified points during the exercise

These capabilities necessitate continuous calculation of most performance-related information.

The scaling of the performance measures was arbitrarily assigned as 0 to 100. This scaling may be modified later as the result of validation efforts.

Much of the sonar/TMA information generated during target approach is in a time-series format, with the value of information collected and the solution accuracy changing over time (e.g., KAST solution versus time on leg). It was necessary to use a reference time period as the basis for computing several of the quantities. This period was selected as 6 minutes. Further developments of these performance measures should include variations in the time period as a function of tactical and TMA (e.g., DBY and SNR) considerations.

The approach position is a term used to define the desired final geometric position of own ship. It represents a desired position of own ship relative to the target. The desired weapon firing point, as denoted by an ideal range and bearing to the target and angle on the bow, would represent the approach position. The approach officer may periodically steer for "zero" bearing rates, attempt to reduce loss of true bearing, and match speed across the line of sight, etc, but in conjunction with the process to solve TMA, he will be maneuvering his vessel to reach some position of advantage in the

## NAVTRAEQUIPCEN 77-C-0107-1

interaction. The approach position concept was developed to provide basic criteria against which to measure performance in reaching this position of advantage. To use this measure for TAT evaluation, an input is required in advance of a scenario for:

- a. TA — track angle; target angle on the bow when in the desired approach position; only the angle (in degrees) is specified, not the orientation (port or starboard)
- b. Rht — Range of the target in yards when in the desired approach position
- c. Own ship aspect

The individual primary performance measures are discussed below, followed by a discussion of the secondary performance measures.

Closing Rate (CR). This measure is developed to express the degree of effectiveness in closing the approach position for the actual value of own speed ( $DMh_o$ ) employed. (See Figure 5.) It will measure the percent of match between target approach position's speed across the line of sight, and own ship's speed across the line of sight, but only when the approach position is actually being closed with a positive value of speed in the line of sight. It is proposed that the instant value of CR as well as the mean value be available. During the time on a TMA leg that the AO wants to evaluate the target's angle on the bow, the CR instant value should be as near to 100 percent as own ship speed constraints permit. On bearing rate TMA lead/lag legs, CR mean value should be used to indicate that true bearing loss is being adequately controlled. That is, this measure would evaluate the smallest increase in  $xDMh_r$  obtainable, consistent with developing a bearing rate to evaluate TMA and still continue to close with some value of  $yDMh_r$ . The present algorithms developed for CR will provide this data; however, scale factors will have to be adjusted to determine the optimum overall CR mean value for selected scenarios.

Time to Station. This is actually a set of complex measures (see Figure 6). Initially, and for each update/calculation step, the measure will state the time, in minutes ( $TS_{(M)}$ ), that it would take to reach the intended approach position (AP), if own ship proceeded at maximum speed to directly intercept the AP. It will also measure the time, in minutes ( $TS_{(N)}$ ), it would take to reach the intended AP at the present value of own ship's speed, if own ship proceeded directly to the AP. A "mean" measure of effectiveness of current own speed, against maximum own speed ( $T_{eff}$ ) is calculated indicating a measure of the ability of the AO to employ ship capabilities in the problem. A fourth value (ICP) is used to measure the effectiveness, as a percentage from 0 to 100, that AO is employing for current own speed, to optimize speed in the line of sight ( $yDMh_r$ ) in order to close the target as soon as possible. (CR, on the other hand, is based on speed across the line of sight ( $xDMh_r$ )). For example, if the AO observes  $TS_{(N)}$  to be 20 minutes to the AP at current own speed, and  $yDMh_r$  will achieve this, ICP will be 100 percent. If  $yDMh_r$  will not achieve this, ICP will indicate, as a percentage, the amount of deviation from reaching an optimum station. A fifth value is calculated at FINEX, which will state as a percentage, the length of time actually required to reach the AP in the scenario from the initial value of  $TS_{(M)}$  at COMEX.

NAVTRAEQUIPCEN 77-C-0107-1

<b>OWNSHIP</b>			<b>CLOSEST POINT OF APPROACH</b>			<b>MOST RECENT FIDU</b>		
CO	355	DEG	BEARING	350	DEG	BY	028	DEG
DMHO	8.0	KTS	RANGE	4500	YDS	SNR	+0.2	DB
HVO	350	FT	TIME	1955		RH		YDS
TIME	1915		<b>APPROACH OBJECTIVE</b>			EUA	+0.5	DEG
<b>PERFORMANCE EVALUATION</b>			TRACK ANGLE (TA) 150 DEG P/S			TIME	1915	
			RANGE OFFSET 8000 YDS			SOURCE SONAR		
CLOSING RATE (CR)			CURSOR RANGE 12000 YDS			<b>SYSTEM SOLUTION</b>		
ACROSS LINE OF SIGHT						BY - DBY	027	L 1.8
NOW	55%	AVG	35%				RH	14500
						CT - DMHT	255	15.0
						SOURCE	SONAR	

$$CR = \left( \frac{So}{\left( \frac{xDMhr+1}{So \times 10^{-2}} \right)} \right) \times SF \times f (+yDMhr)$$

SF = Scale Factor

HVT (EST) 200 FT

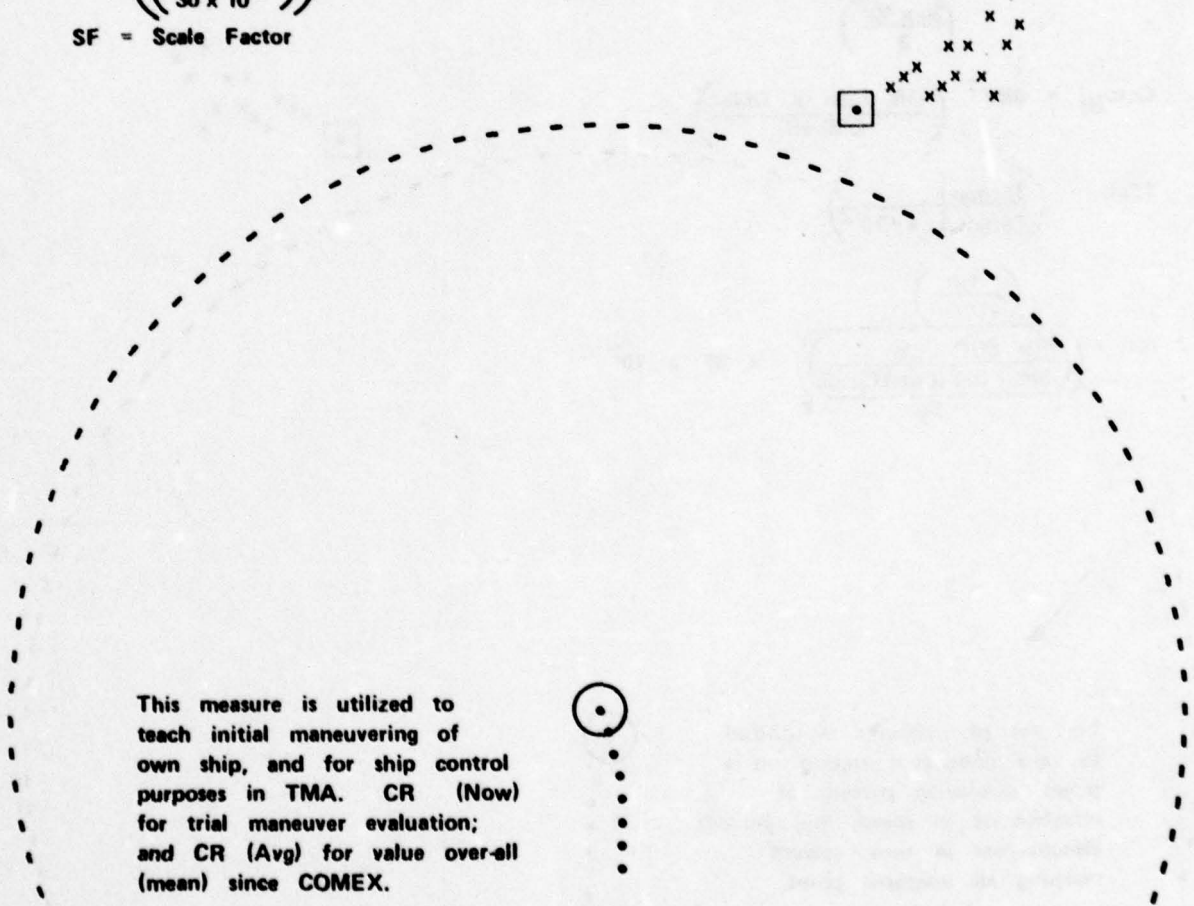

Figure 5. Performance Measure: Closing Rate

NAVTRAEQUIPCEN 77-C-0107-1

<b>OWNSHIP</b>			<b>CLOSEST POINT OF APPROACH</b>			<b>MOST RECENT FIDU</b>		
CO	355	DEG	BEARING	350	DEG	BY	028	DEG
DMHO	8.0	KTS	RANGE	4500	YDS	SNR	+0.2	DB
HVO	350	FT	TIME	1955		RH		YDS
TIME	1915		<b>APPROACH OBJECTIVE</b>			EUA	+0.5	DEG
<b>PERFORMANCE EVALUATION</b>			TRACK ANGLE (TA)	150	DEG P/S	TIME	1915	
			RANGE OFFSET	8000	YDS	<b>SOURCE SONAR</b>		
<b>TIME TO STATION (TS)</b>			CURSOR RANGE	12000	YDS	<b>SYSTEM SOLUTION</b>		
NOW	78%	AVG	85%				BY - DBY	027 L 1.8
						RH	14500	
						CT - DMHT	255	15.0
						SOURCE	SONAR	

$$TS_{(f)} = \frac{Rh \sin Cqts}{\sin 180 - (Cqto_{(f)} + Cqts)} \left( \frac{So \times 10^2}{3} \right)$$

HVT (EST) 200 FT

$$Cqto_{(f)} = \sin^{-1} \left( \frac{\sin Cqts \times DMht}{DMho(f)} \right)$$

$$TS_{eff} = \left( \frac{TS(max)}{TS(now)} \times 10^{-2} \right)$$

$$ICP = \left( \frac{Rh \sin Cqts}{\sin 180 - (Cqts + Cqto)} \right) \times SF \times 10^2$$

This set of measures is utilized to take designated station on a target, displaying percent of effectiveness in speed, and percent effectiveness in time, toward reaching an intercept point.

Figure 6. Performance Measure: Time to Station

Solution Accuracy (SA). This measure evaluates the AO's ability to develop a maximum change in DBy between TMA legs as compared with the actual change observed. (See Figure 7.) This measure is calculated for the actual value of own speed employed. Specifically, as now developed in the algorithm, if own speed equals  $x$ , and own ship observed a DBy of  $R-1$  on the present TMA leg, and the maximum bearing rate that could be obtained with own speed equal to  $x$  is  $L-6$ , then a change in DBy of  $7/M$  would provide a 100-percent contribution to solution accuracy. Maneuvers resulting in smaller changes result in smaller values of SA. In the example, if on the second leg DBy were at  $L-6/M$ , the AO would have to maneuver to achieve at least a "zero" bearing rate on the new leg to keep change in DBy maximum for every maneuver. The value of SA can be affected by SNR, in order to require more than two legs to achieve a higher value of SA.

Probability of Counterdetection (PCD). Values of PCD are displayed with average as well as instant values to appraise the total effect of PCD in the approach (Figure 8).

Quality of Approach (QA). This is a complex measure which is considered to be most meaningful if computed at the FINEX of a scenario (see Figure 9). Interim time periods could also be sampled for an idea of QA, particularly to see whether performance degrades with time. However, many values might conceivably start high and degrade as a normal function of the various tradeoffs in any tactical situation. The present development in the QA algorithm is as an average of all the mean values of  $CR$ ,  $TS_{EF(M)}$ ,  $ICP_{EF(M)}$ , and  $SA_{(M)}$ . Solution accuracy is weighted to recognize its priority over the other quantities in the approach. PCD is heavily weighted to recognize its tactical implications.

Secondary Performance Measures. A variety of tactically relevant parameters are readily available from the scenario encounter, and pertinent to performance and training. These generally pertain to specific aspects of an individual's performance occasionally representing tactical goals. The primary measures discussed above pertain to the FCC/AO level, which represent the main thrust of the TAT training segment. The secondary performance measures pertain to the FCC/AO, MK 81 analyzer operator and aspects of team performance (see Table 2). These should also be addressed during the TAT training.

The performance measures were developed as tools to be used during training, as part of TAT. They are used differentially during each module (see Table 3). Their primary purpose is to provide objective performance information to enhance the training process (e.g., quantitatively indicate the relationships between different tactical actions). The algorithms, with the exception of PCD, were developed for the TAT segment. They have not been used in submarine tactical operations, developmental efforts, or training programs. Nevertheless, they should be acceptable to the officer trainees, since they were developed to reflect operational doctrine and practice. Furthermore, they were reviewed by SUBSCOL and SUBGROUP TWO personnel, and generally found to be acceptable for the TAT evaluation purpose. This method of development ensures them an adequate degree of face validity. The measures should be refined and validated through application prior to their use in the TAT evaluation or in operational tactics training.

NAVTRAEQUIPCEN 77-C-0107-1

<b>OWNSHIP</b>			<b>CLOSEST POINT OF APPROACH</b>			<b>MOST RECENT FIDU</b>		
CO	355	DEG	BEARING	350	DEG	BY	028	DEG
DMHO	8.0	KTS	RANGE	4500	YDS	SNR	+0.2	DB
HVO	350	FT	TIME	1955		RH		YDS
TIME	1915		<b>APPROACH OBJECTIVE</b>			EUA	+0.5	DEG
<b>PERFORMANCE EVALUATION</b>			TRACK ANGLE (TA) 150 DEG P/S			TIME	1915	
			RANGE OFFSET 8000 YDS			<b>SOURCE SONAR</b>		
<b>SOLUTION ACCURACY (SA)</b>			CURSOR RANGE 12000 YDS			<b>SYSTEM SOLUTION</b>		
NOW	78%	AVG 55%				BY - DBY	027	L 1.8
						RH	14500	
						CT - DMHT	255	15.0
						SOURCE	SONAR	

$$SA = \left( \frac{[DBy_1 - DBy_2] + .1}{DBy_{max} \times 10^{-2}} \right) \cdot f(SNR) \times SF$$

HVT (EST) 200 FT

SF = Scale Factor

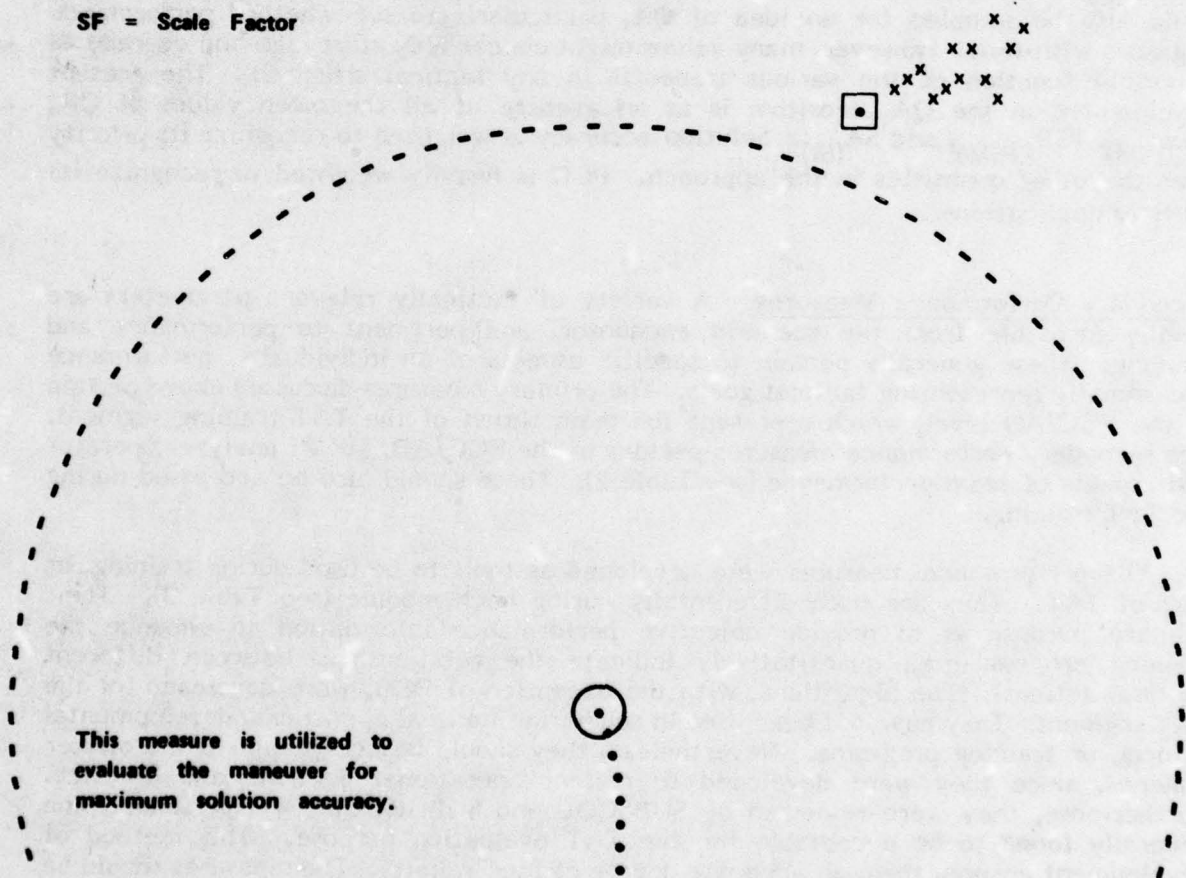

This measure is utilized to evaluate the maneuver for maximum solution accuracy.

Figure 7. Performance Measure: Solution Accuracy

NAVTRAEQUIPCEN 77-C-0107-1

<b>OWNSHIP</b>			<b>CLOSEST POINT OF APPROACH</b>			<b>MOST RECENT FIDU</b>		
CO	355	DEG	BEARING	350	DEG	BY	028	DEG
DMHO	8.0	KTS	RANGE	4500	YDS	SNR	+0.2	DB
HVO	350	FT	TIME	1955		RH		YDS
TIME	1915		<b>APPROACH OBJECTIVE</b>			EUA	+0.5	DEG
<b>PERFORMANCE EVALUATION</b>			TRACK ANGLE (TA) 150 DEG P/S			TIME	1915	
			RANGE OFFSET 8000 YDS			SOURCE SONAR		
			CURSOR RANGE 12000 YDS			<b>SYSTEM SOLUTION</b>		
<b>PROBABILITY OF COUNTERDETECTION (PCD)</b>						BY - DBY	027	L 1.8
NOW 48% AVG 32%						RH	14500	
						CT - DMHT	255	15.0
						SOURCE	SONAR	

HVT (EST) 200 FT

$$Pcd = f(NFM_t) \times NSE_o \times SF$$

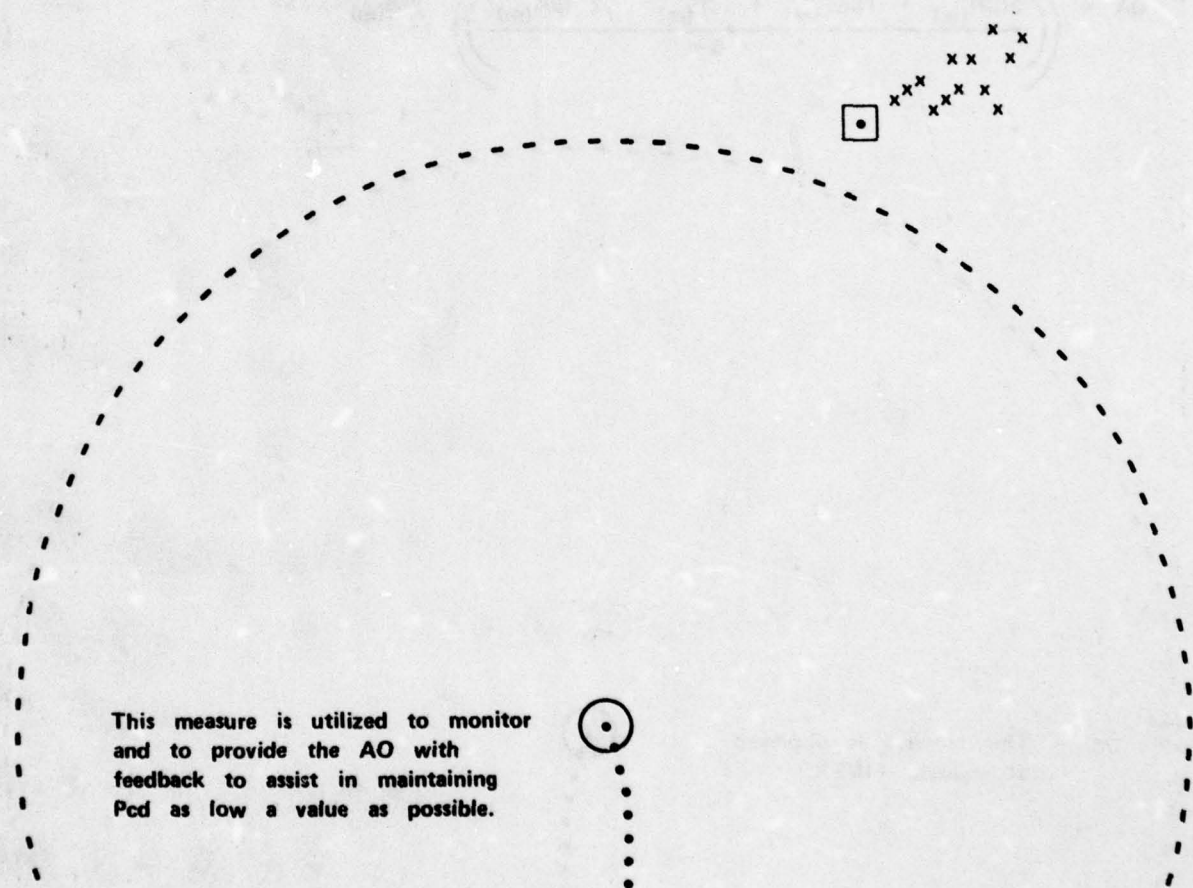

This measure is utilized to monitor and to provide the AO with feedback to assist in maintaining Pcd as low a value as possible.

Figure 8. Performance Measure: Probability of Counterdetection

NAVTRAEQUIPCEN 77-C-0107-1

<b>OWNSHIP</b>			<b>CLOSEST POINT OF APPROACH</b>			<b>MOST RECENT FIDU</b>					
CO	355	DEG	BEARING	350	DEG	BY	028	DEG			
DMHO	8.0	KTS	RANGE	4500	YDS	SNR	+0.2	DB			
HVO	350	FT	TIME	1955		RH		YDS			
TIME	1915		<b>APPROACH OBJECTIVE</b>			EUA	+0.5	DEG			
<b>PERFORMANCE EVALUATION</b>			TRACK ANGLE (TA)	150	DEG P/S	TIME	1915				
			RANGE OFFSET	8000	YDS	<b>SOURCE SONAR</b>					
<b>QUALITY OF APPROACH (QA)</b>			CURSOR RANGE	12000	YDS	<b>SYSTEM SOLUTION</b>					
			NOW 55% AVG 35%						BY - DBY	027	L 1.8
									RH	14500	
									CT - DMHT	255	15.0
									SOURCE	SONAR	

HVT (EST) 200 FT

$$QA = \left( \left( \frac{2(CR_{(m)} + TSEF_{(m)} + ICP_{(m)} + 2(SA_{(m)}))}{5} \right) \cdot Pcd_{(m)} \times SF \right)$$

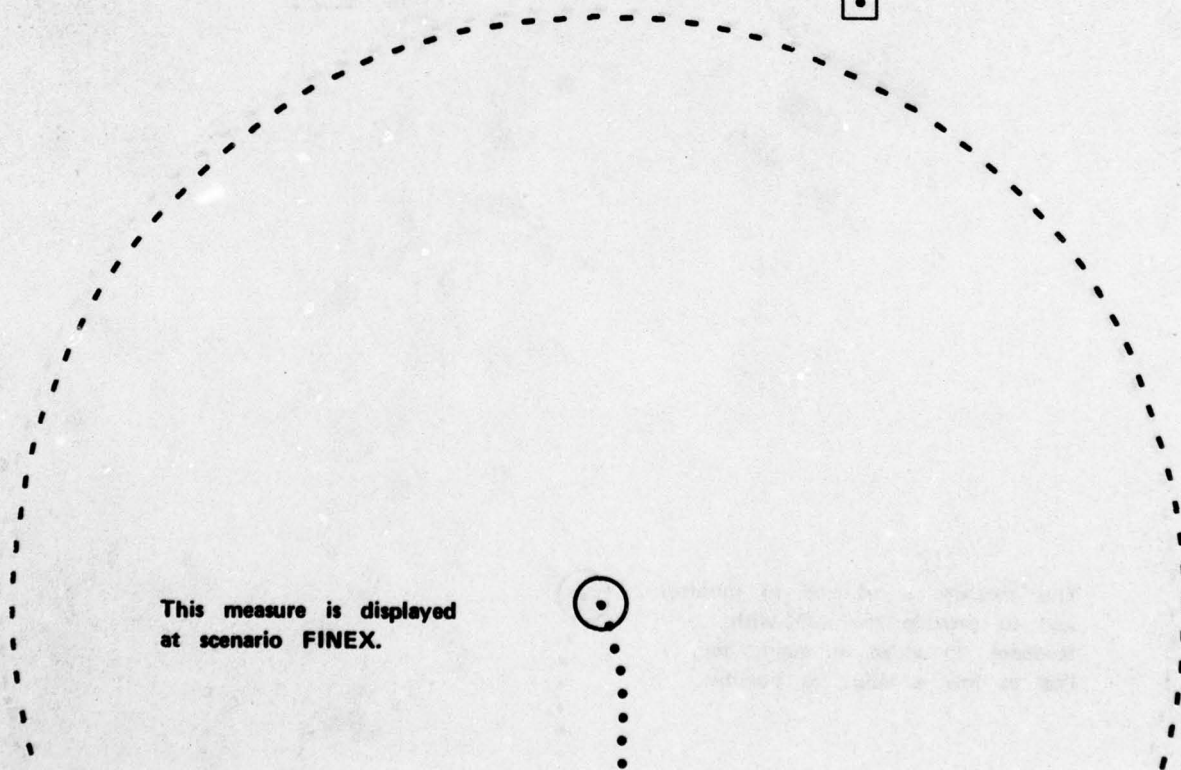

Figure 9. Performance Measure: Quality of Approach

TABLE 2. SECONDARY PERFORMANCE MEASURES

Individual Performance Measures

- a. 21A37 — AC4 Tactics at FCC Level:
  - (1) Time to recognize target maneuvers
  - (2) Accuracy of target data analysis
  - (3) Number of procedural errors in a given scenario
  - (4) Number/direction/magnitude of own ship maneuvers recommended for TMA versus established criteria for specific situation
  - (5) Quality of overall approach; i.e.,:
    - (a) Time to maximize SNR
    - (b) Total average  $xDMh_o$ ,  $yDMh_o$
- b. 21B63 MK 81 Analyzer Operator:
  - (1) Number of bearings edited versus total number of noisy or questionable bearings
  - (2) Time to recognize target maneuver
  - (3) Time to edit KAST
  - (4) Time to re-evaluate/get MATE solution
  - (5) Accuracy of MATE solution
  - (6) Use of KAST data to evaluate MATE
  - (7) Use of environmental data entry (EDE) data
  - (8) Quality of recommendations for own ship TMA maneuvers; i.e., point, lead, lag, magnitude, and timing
  - (9) Recognition of SNR versus bearing quality
  - (10) Procedural errors

Team Performance Measures

Performance measures for grouping team performance should reflect the team's ability to communicate tactical information and coordinate tactical operations. Measures of team performance may be:

- a. The rate at which the plot coordinator receives TMA data slips and rate at which he provides data to plots
- b. Rate of solution convergence as a function of data updates
- c. Time from target maneuver recognition by first member of FC party to FCC (or AO) pronouncement of definite target maneuver
- d. Time to accomplish tactical objective
- e. Time to complete training objective

TABLE 3. PRIMARY PERFORMANCE MEASURES USED DURING EACH MODULE

PERFORMANCE MEASURE	MODULES				
	INITIAL TARGET MOTION ANALYSIS	TMA MANEUVERS SOLUTION ACCURACY	TMA MANEUVERS CLOSING RATE	PCD CONSIDERATIONS	OPTIMUM GEOMETRY
CLOSING RATE (CR)			X	X	X
TIME TO STATION (TS)	X		X		
SOLUTION ACCURACY (SA)	X	X			X
PROBABILITY OF COUNTERDETECTION (PCD)				X	X
QUALITY OF APPROACH (QA)					X

TAT DISPLAYS. Display requirements were developed to support the specific training needs of the TAT segment. Three different formats resulted for use in diagnostic information feedback and demonstration applications. The MK 81 WCC tactics mode display format was selected to provide overall situation information, including alternative target tracks. This display will be used for those aspects of training when addressing the problem as a whole (e.g., recounting own ship and target actions).

The general purpose graphing display (see Hammell, Gasteyer, and Pesch, 1973; Hammell, Pesch, Ewalt, and Rabe, 1976), consisting of three graphs, will be used for illustrating the relationships between variables. This display has been developed and used with the laboratory experimental training simulation TAT system. It consists of three graphs each capable of displaying any recorded parameter versus any other; typically, it is used for graphing parameters versus time. Tactical variable relationships can be illustrated by comparing the variables across two or three graphs. The basic three-graph display has been modified to include multiple traces on each graph; this permits direct comparison of alternative tactics effects. Other modifications include digital X,Y readouts at the point where an adjustable vertical cursor cuts each graph trace. This display is extremely flexible due to its general purpose format and very adaptable to the investigation of a wide variety of issues.

The third display is of a special purpose format, designed specifically to investigate the effects of own ship maneuvers. Its format was designed similarly to the familiar line-of-sight diagram, with additional graphical and alphanumeric information representing various alternative maneuvers. This display generates comparative information on relevant tactical parameters for up to nine alternative maneuvers. The display is used for demonstration, explanation, and feedback. Some degree of flexibility is available in format of information displayed, since little data is available in the research literature to guide the design of an alphanumeric/graphic display. This display represents one of many possible special purpose displays that can directly address tactical training issues.

Each display format is explained in greater detail in Appendix G.

## RESEARCH AND DEVELOPMENT PLAN

The research and development plan identifies areas of needed tactics training research, establishes research priorities, recommends research structure and scheduling, and presents a detailed plan for initial investigations. This plan pragmatically represents the current training research needs of the submarine training community from the design, implementation, and evaluation standpoints.

The plan recommended three levels of research under which twelve areas should be investigated. The three levels (see Figure 10) are:

- a. Level I. Fundamental investigations in a highly controlled laboratory environment. This level should investigate a wide variety of issues, narrowing the field to those that have potential for application in submarine tactics training.

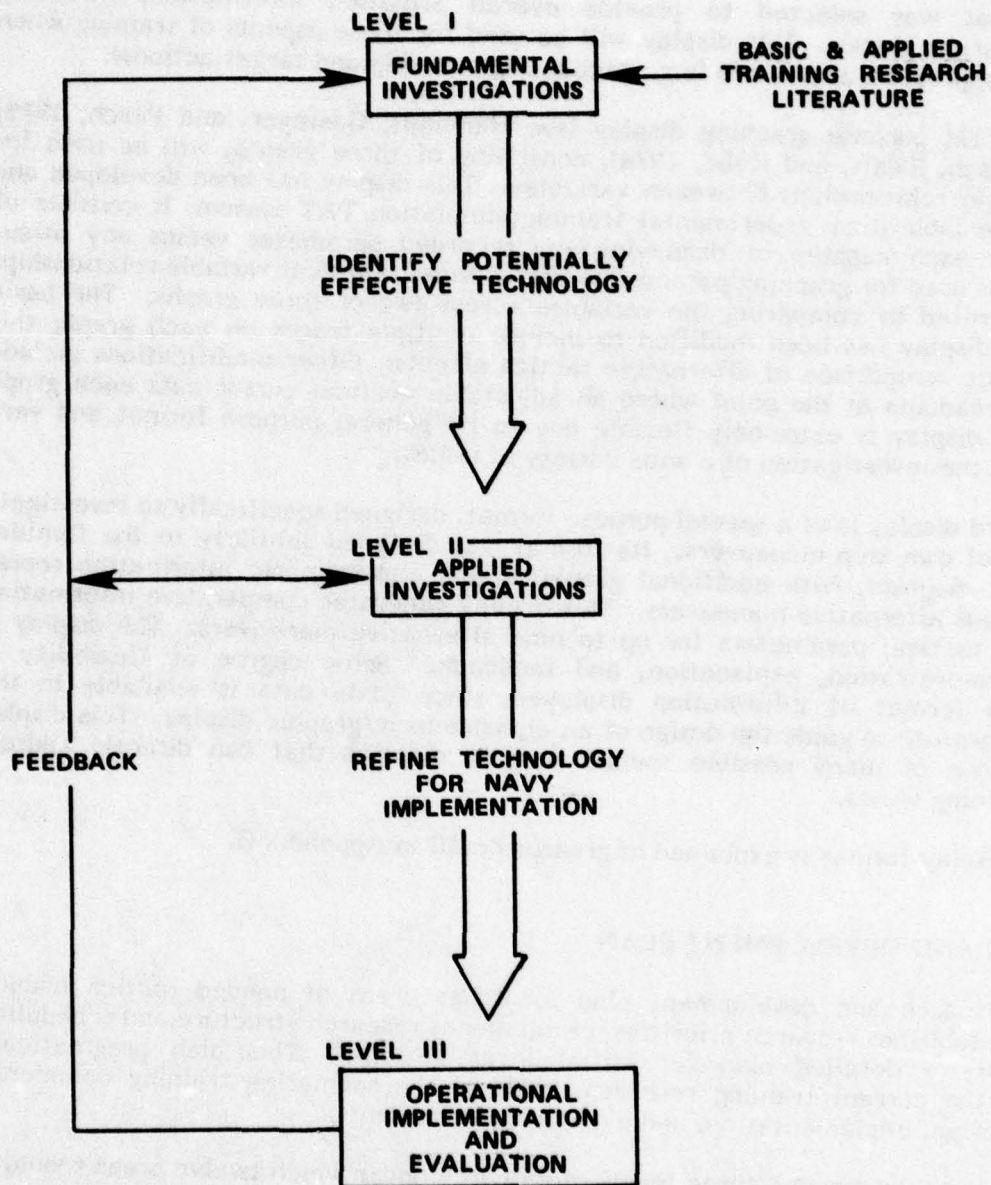

Figure 10. Flow Diagram of Investigation Structure

- b. Level II. Applied investigations bridging the gap between the laboratory and the operational implementation. These efforts should ascertain the effectiveness of the issues recommended by the laboratory research, identifying those that should be implemented and developing them for implementation.
- c. Level III. Implementation, evaluation, and refinement of the training system capabilities in the operating training setting. These efforts should update and improve the operational capabilities, providing feedback concerning results and needs to the preceding levels.

These levels of research should be conducted in a closely integrated reciprocating fashion. Although research issues can originate at any level, they should generally originate at the first level and proceed through the structure. An information flow and analysis system was also proposed for directing research within the structure and dissemination of information.

The twelve areas of recommended research cover a wide variety of relevant issues (see Table 4). Many additional areas exist. These twelve areas, however, were deemed as the most important. The areas were identified from the research literature and investigation of submarine tactics training needs. It should be noted that they represent research needs, and do not necessarily represent operational training needs. The order of listing in Table 4 represents the recommended order of priority. Recommendations for the scheduling of eight of the research areas are presented in Figure 11. Each of these areas is discussed in detail in the research and development plan, along with the other aspects of the plan. This plan has been submitted under separate cover to NAVTRAEQUIPCEN.

#### MODIFICATIONS TO THE TRAINING MODEL

The training model, Submarine Tactical Operations Model (SUBTOM), was developed for the experimental training simulation trainer (see Pesch et al, 1974; Hammel et al, 1976) to demonstrate TAT capabilities. It was modified during this project for the purposes of (1) evaluating the exercises developed for the SUBSCOL/TAT evaluation, and (2) providing the training context during the applied TAT evaluation in the EA laboratory. These modifications were accomplished separately for each purpose; they are discussed together, however, since they represent the capabilities of the training model.

Several types of model modifications were made: (1) modification of the model's structure to enable additional capabilities within the limitations of the hardware/software configuration, (2) modification and addition of capabilities to support the developed TAT training process, and (3) addition or modification of capabilities to facilitate the instructor trainee/device interaction. A summary of the modifications is presented below.

The SUBTOM program structure was modified to enable the use of an alternative tactics capability. This required the generation of multiple data files, and accessibility of the TAT operational display as well as the other feedback displays. The major change was the modification of the scenario initialization sequence to permit multiple data files and to control their access. This capability permits the restarting of a

TABLE 4. RESEARCH AND DEVELOPMENT AREAS LISTED IN ORDER OF PRIORITY

<u>Research and Development</u>	Investigation Structure Level		
	<u>I</u>	<u>II</u>	<u>III</u>
1. Feedback Displays	X	X	X
2. Trainee/Instructor/Device Interaction	X	X	X
3. Interactive Adaptive Target	X	X	X
4. Training Techniques	X	X	
5. Transfer of Training			X
6. Performance Measures and Standards		X	X
7. Application of TAT to Other Trainers		X	
8. Training Environment	X	X	
9. Trainee Condition	X		
10. Fidelity		X	
11. Performance Library		X	
12. Data Collection Techniques		X	

... of the ... and ... the ... of the ...

... the ... of the ...

... the ... of the ...

... the ... of the ...

... the ... of the ...

... the ... of the ...

... the ... of the ...

... the ... of the ...

... the ... of the ...

... the ... of the ...

... the ... of the ...

... the ... of the ...

... the ... of the ...

... the ... of the ...

... the ... of the ...

... the ... of the ...

... the ... of the ...

... the ... of the ...

... the ... of the ...

AREAS  
 9  
 10  
 11  
 12

■ - LEVEL I  
 ● - LEVEL II  
 ▲ - LEVEL III

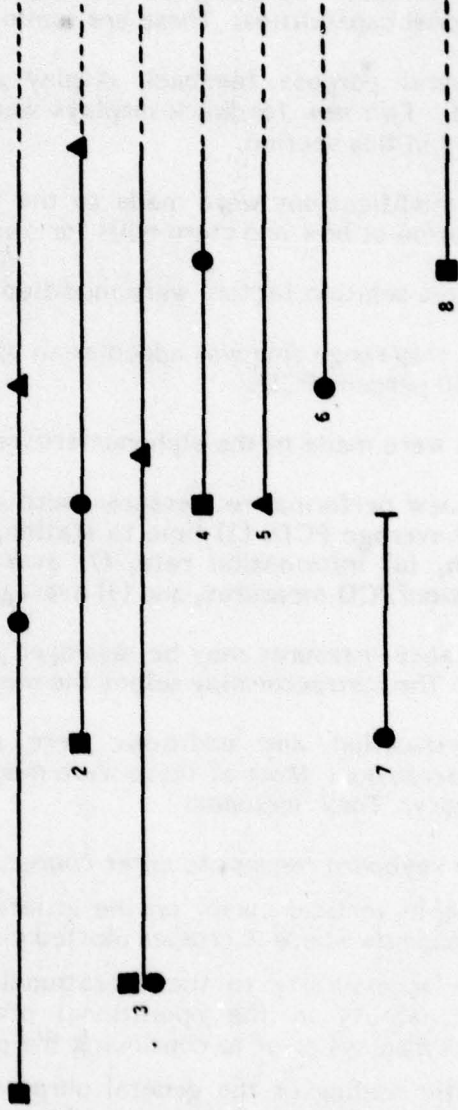

78 . . . . . 79 . . . . . 80 . . . . . 81 . . . . . 82

Figure 11. Schedule for the Establishment of Investigative Programs

## NAVTRAEQUIPCEN 77-C-0107-1

problem at any point in time, and generates independent own-ship track (i.e., up to nine independent tracks). It further enables the simultaneous comparison of recorded tactical and performance parameters on the feedback displays for each of the alternatives.

The majority of effort updating the model was concentrated on the modification and addition of model capabilities. These are summarized below:

- The general purpose feedback display and TAT operational display were modified. Two new feedback displays were developed. These are previously addressed in this section.
- Several modifications were made to the tactical models, including modification/addition of bow and stern nulls for own ship and target
- The system solution factors were modified to speed up convergence
- The own ship range ring was added as an option in place of the automatic range ring at 50 percent PCD.
- Changes were made to the alphanumeric readouts.
- Several new performance measures were added, including: (1) average closing rate, (2) average PCD, (3) time to station, (4) solution accuracy, (5) quality of approach, (6) information rate, (7) average information rate, (8) combined information/PCD measures, and (9) average combined information/PCD.
- Performance measures may be displayed in real time on the TAT operational display. The instructor may select the measure for display.

Several modification and additions were made to facilitate the instructor trainee/device interaction. Most of these were made with regard to the TAT evaluation in the EA laboratory. They included:

- A single keyboard request to enter course and speed commands
- A moveable vertical cursor on the general purpose graphing display, giving X and Y readouts where it crosses plotted curves
- Flexible accessibility to the operational and feedback displays, including a pause capability in the operational problem that allows investigation of feedback displays prior to continuing the problem
- Automatic scaling of the general purpose graphs in correspondence with the set of alternatives displayed on each graph. These capabilities, although not affecting the TAT function, assist in the use of TAT

The modifications were correlated to the specific training processes developed. They presuppose a particular TAT configuration. The TAT and model capabilities should be designed with regard to their specific use in every training situation. This is particularly true regarding feedback information, such as that which the special purpose feedback displays provide.

## SECTION IV

## EMPIRICAL INVESTIGATION OF TRAINING ASSISTANCE TECHNOLOGY

## INTRODUCTION

Training assistance technology (TAT) capabilities are conspicuously absent from many training systems, both commercial and military, including those in the submarine training area. Although TAT concepts may appear intuitive to training experts, they have not been fully understood or requested by the simulator designer and user. The necessity exists, therefore, to demonstrate the relative effectiveness of a training process embodying TAT capabilities. This investigation evaluated TAT capabilities in comparison with the traditional training process.

The laboratory investigation of TAT was undertaken for the purpose of evaluating the effectiveness of these capabilities for applied submarine tactics training. The necessity for empirical data regarding TAT's effectiveness was apparent. An opportunity developed for a brief laboratory experiment prior to the operational training investigation. This experiment, in addition to providing objective information regarding TAT's effectiveness, would provide useful information regarding the specific design and implementation of TAT capabilities. TAT represents a set of general capabilities that are part of a training system. Their specific design and use configuration depends on the particular training situation.

The TAT capabilities have been demonstrated for several submarine tactics training situations in the laboratory setting (Hammell, Pesch, Ewalt and Rabe, 1976). Many alternative approaches exist for the configuration and use of TAT in particular training situations, each of which is likely to differ in regard to its relative effectiveness. For example, the amount and format of information on a feedback display may greatly affect the rate of learning. Little is known about the effectiveness of TAT, much less about the effectiveness of the multitude of possible TAT configurations. This area of research is in its infancy, at least with regard to submarine tactics training. The initial investigations of TAT, therefore, may inadvertently be based on suboptimal configurations. This was considered to be a major problem faced during the laboratory investigation, as well as the operational training investigation.

Variables considered for investigation included the level of trainee input characteristics (e.g., officer rank, prior training, and experience) and degree of familiarity with CRT-type consoles. A simple experimental design was decided upon due to the possible wide variation in subjects, variables, and their interaction with a TAT configuration. Resource considerations further strengthened this decision. A relatively simple laboratory experiment was designed to compare the effectiveness of a simulator-based training process with and without TAT capabilities. This experiment was conducted in an applied submarine tactical training context, using experienced submarine personnel as subjects.

## APPROACH

The approach followed in the design of the experiment was to achieve contrasting traditional and TAT training processes. The traditional training process followed the current tactics training approach, while the TAT training process was configured with regard to the TAT capabilities. This design approach, however, was limited by the absence of information to guide the design of a TAT configuration. In other words, the design represents a judgment as to the use of TAT. Resource considerations further constrained the design. A total of 48 hours was allocated to trainee interaction, which included pre- and posttraining briefings, as well as the training period itself. This constraint had a direct impact on the number of trainees used as well as the amount of training time per individual. A relatively short training program (i.e., approximately 3 hours) was necessitated.

The short training program was developed to achieve a specific tactical objective in target approach tactics. The tactical objective was:

The commanding officer will be capable of selecting an own ship maneuver (i.e., course and speed) to optimally position own ship in relation to the target, and thus achieve an optimum balance between two independent, and sometimes conflicting, tactical parameters (i.e., probability of counterdetection and information quality).

This situation is operationally real, although all of the specific characteristics of the tactical objective are not currently used. The tactical objective represented an extension of current operational doctrine, in an attempt to ensure some degree of training potential for all trainees.

The trainee acted as the commanding officer of own ship, interacting with a simulated MK 81 tactics mode display. In particular, he interacted with the Geosit submode of the tactics mode display (see Figure 12), selecting own ship course and speed to attain the desired tactical position in relation to the target. (An explanation of the tactics mode display is contained in Appendix G). The trainee's performance was evaluated on the basis of a summary performance measure that reflected the tactical training objective. Details of the experiment are presented below.

**EXPERIMENTAL DESIGN.** The experimental design consisted of two groups, each of which received individualized training: (1) the TAT-trained experimental group, and (2) a traditionally trained tactics group. Each group participated in a series of 10 training exercises using the simulator. Each exercise included a tactical scenario in which the trainee performed, yielding a summary performance datum for each trainee in each exercise.

Five distinct scenarios were developed presenting different tactical problems to the trainee, requiring unique tradeoffs in achieving an optimum own ship maneuver. The tactical parameters (e.g., OS and target speed, angle on bow (AOB), aspect, and range) were randomly varied within the design of the first five scenarios. Their mirror-image scenarios were then randomly distributed among the second five exercises. Each trainee received the same sequential order of the 10 different tactical scenarios, representing five fundamentally different situations. This design enabled the investigation of several aspects of the learning curves.

OWNSHIP	CLOSEST POINT OF APPROACH	MOST RECENT FIDU
CO DMHO HVO TIME	BEARING RANGE TIME	BY SNR RH EUA TIME SOURCE
PERFORMANCE EVALUATION	APPROACH OBJECTIVE	SYSTEM SOLUTION BY - DBY RH CT - DMHT SOURCE
	CURSOR RANGE	

HVT (EST)



Figure 12. Tactics Mode Display

Several analyses were planned to investigate the two predominant aspects of the learning curve: (1) the relative level of final achievement, and (2) the rate of learning. The level of achievement was evaluated by comparing the performance on the first and last scenarios, with the training gain represented by the difference. Furthermore, absolute achievement differences between the TAT and traditional training processes were compared on the basis of the final exercise/scenario.

Differences in the rate of learning were evaluated by comparing performance on the first scenario with performance during the middle group (i.e., 5, 6, 7) and final group (i.e., 8, 9, 10) of scenarios. Several analytical techniques were appropriately used. These included:

- a. A comparison of the overall group variances using the Hartley F-test for homogeneity of variance (Winer, 1971, pages 206-207).
- b. A comparison of the overall group means using the nonparametric Mann-Whitney test statistic (Siegel, 1956, pages 116-126).
- c. A comparison of the groups means for specific segments of the training process, i.e., an analysis of the TAT group's mean performance relative to a confidence interval probability predicted from the control group's mean performance on the same training segment (Downie and Starry, pages 109-111).

**TRAINING PROGRAM.** The training program design was developed with the experimental design and selection of the tactical training objectives. This was necessary due to the available time for trainee interaction (i.e., 48 hours). It was also necessary to closely integrate each of these elements to achieve a potentially effective training experiment. Hence, these elements were developed around a 3-hour training program (i.e., 48 total hours divided by two groups of six subjects each, allowing time for training system description, training exercise overview, and pre- and posttest administration. Furthermore, the approach taken was to provide a vast amount of training, thus allowing maximum exposure to TAT for the experimental group.

The training program was designed for an intermediate level of tactical expertise, approximately equivalent to that of the Submarine Officers Advanced Course. The program addressed a small segment of the broad submarine tactics area, relying on the trainee's considerable tactical expertise for those aspects not addressed. The training program could thus be thought of as part-task, addressing a narrow subset of tactical skills.

The training program was designed around 10 brief exercises, preceded by a short presentation. The presentation identified the tactical objective and performance considerations, and explained the functioning of relevant tactical parameters. The series of 10 exercises was conducted with the trainee sitting in front of the MK 81 simulator. Each exercise consisted of (1) a short tactical scenario during which the trainee maneuvered own ship to achieve the tactical objective, (2) delayed feedback regarding his performance, and (3) instructional information pertaining to the makeup and tradeoff considerations of the relevant tactical variables. Practice, evaluation, and instruction were involved in each exercise. An outline of the experimental (TAT) and control (traditional) group exercises is contained in Appendices H and I, respectively.

The tactical scenarios represented different geometrical situations, each of which required different tradeoffs to be made in achieving the relatively optimum own ship maneuver. The tactics mode display of the MK 81 provided information with which the trainee could assess the situation and then select the maneuver. The simulator was run in fast time (i.e., about 10 times actual time), shortening the scenario time considerably. Each of the scenarios was reviewed by SUBSCOL personnel and appropriate modifications were made. The major criticism centered on the fast-time procedure, and the allowance of only a single own ship maneuver. Often, in at-sea situations, a series of maneuvers would be made rather than a single average maneuver. This deficiency, although relevant, was considered necessary to enable a sufficient number of exercises to be conducted (i.e., regarding training and the number of data points). Details of the scenarios are contained in Appendix J.

The exercises were similar for both groups, but the training methodologies differed in regard to feedback and instructional information, as well as in their means of presentation. A traditional tactics training process was used for the control group. This process was based on the information and displays normally available for tactics training, which are generally limited to operational displays and track plots. Performance measures and diagnostic feedback displays are not currently available on submarine tactics trainers. Acceptable validity of the traditional training process was ensured by developing it with the advice of SUBSCOL instructors.

The training process for the experimental group was designed to utilize several TAT capabilities. Tactical performance parameters, such as the probability of counterdetection, were generated and made available in several forms for feedback. Two diagnostic feedback display formats were used to aid in directing the trainee's performance and to illustrate relationships between tactical parameters. These were (1) a line-of-sight format displaying projected geometrical relationships and tactical parameters (e.g., signal-to-noise ratio) for several alternative and actual own ship maneuvers; and (2) a general purpose graphic display allowing for the plotting of any tactical situation and performance parameters. The graphic display allows these relationships and the effects of alternative actions to be investigated. (Additional details of these displays are contained in Appendix G.) Finally, the capability was available to investigate and compare the effects of alternative own ship maneuvers with the actual maneuver on the basis of the variety of tactical parameters available for display. A combination of these TAT capabilities was used during each exercise. They provided information feedback regarding the specific results of own ship actions. They enabled detailed investigation of the tradeoffs with alternative actions. They assisted in the instruction regarding the characteristics of particular tactical parameters and their interactions.

A major consideration in the design of the exercises, as well as selection of the tactical training objective, was the availability of an objective summary measure of performance. A variety of tactical parameters were used to provide feedback during training. These included, for example, the signal-to-noise ratio over time and target angle on the bow. A summary measure, representing the tactical objective, was necessary, however, to assess the differences between traditional and TAT training processes. A composite measure was developed based on two independent tactical parameters, each of which was weighted equally. These were (1) the probability of counterdetection (PCD), and (2) the quality of sensor information (I). Algorithms were

developed for each, based on several other relevant tactical parameters (e.g., signal-to-noise ratio). The trainee's tactical performance was represented by a composite of these two parameters (IP) based on their average value during the 10-minute period following the own ship maneuver. The optimum tactical solution was the highest possible combined value for the particular situation. The performance measure was designed to be tactically relevant and sensitive to differences in own ship deployment. The tactical problem was enhanced by the often opposite actions called for by each of the two tactical parameters. Some tradeoffs were necessary to achieve satisfactory solutions. Furthermore, the values of the respective parameters were not presented by the tactics mode display, and thus required estimation based on available tactical information. These factors contributed to the training potential of the tactical situation.

**TRAINEES.** Twelve submarine officers considered to be at an average intermediate level of tactical expertise were selected as the trainees. Individual expertise and background varied substantially, as indicated by completed biographical sketches. The trainees were paired on the basis of background factors and randomly assigned to the experimental and control groups. It should be noted that many of the trainees had some experience with CRT type operational displays, either MK 81 tactics mode display or MK 78 Analyzer. Background details of the officer trainees are summarized in Appendix K.

**APPARATUS.** The training program was conducted using a simulation of the Geosit submode display of the MK 81 tactics mode display. This display presents sonar and target motion analysis information for the target, as well as own ship motion information and geographical/situation plots of own ship and target tracks. It is used operationally for evaluation of the situation and planning of own ship actions. The simulation is based on an extensive two-submarine interaction model developed specifically for this laboratory experimental training simulation (see Hammell, Ewalt, and Rabe, 1976). The simulation model is currently operating at Eclectech Associates' facility and the NAVTRAEQUIPCEN Human Factors Laboratory. The prototype/model also includes a variety of TAT capabilities. Several modifications were made to the submarine tactical operations model (SUBTOM) to:

- a. Update the Geosit submode display
- b. Generate specific diagnostic feedback display characteristics necessary for this training program
- c. Provide for specific instructor/simulator interface requirements necessary to conduct the training
- d. Generate specific performance measurement algorithms for use during training
- e. Develop other general model capabilities

The TAT capabilities were specifically configured for this experiment as a result of these modifications.

The simulation was based on a modified Digital Equipment Corporation GT-44 system, primarily consisting of a PDP 11/40 computer, 17-inch CRT, and general purpose keyboard. All visual information was presented on the single CRT display. The information used for feedback and instruction was generated by the model during the scenario and stored on a disk for later retrieval, or was generated later in real-time by the model upon request by the instructor. Hard copy summaries of all relevant parameters were made following each scenario, enabling later reconstruction.

**PROCEDURE.** The experimental procedure was the same for the experimental and control groups, with the exception that the former group had use of the TAT capabilities during training. Before and after the training session all trainees completed a written test assessing their level of tactical knowledge in the general subject area. Completion of the pretest was followed by a brief familiarization period during which the tactics mode display was explained. The information feedback and instruction formats were then explained; the experimental group was shown the TAT capabilities at this time. The series of 10 exercises, comprising the training program, were then administered consecutively. Each exercise consisted of, in order:

- a. The scenario, requiring the trainee to maneuver own ship
- b. Feedback exploring the trainee's actions during the preceding scenario
- c. Instructions explaining the relevant tactical variables and their interactions

The first scenario was considered as the operational pretest; the last scenario was considered as the operational posttest. The written posttest was administered following completion of the final exercise, thus completing the experimental session. Each trainee in both groups participated in this procedure individually. A detailed chronology of this procedure is presented in Table 5.

## RESULTS

The data were analyzed to evaluate the relative effectiveness of the training with TAT capabilities in comparison with a traditional submarine tactics training process. Specifically, the data were evaluated to investigate (1) training gain differences on the basis of pre- and posttraining performance, and (2) rate of training gain differences on the basis of performance during the training program. The summary performance measure (IP) was the basis for the analyses. The data collected from each subject's IP performance for each of the ten scenario trials are shown in Figure 13.

A homogeneity of variance test was performed on the data prior to the analysis for experimental effects. The variance of the TAT group was found to be significantly less than that of the traditional group ( $F=2.28$ ;  $d_f=2,59$ ;  $p<0.01$ ). The individual scenario variances for the two groups are plotted in Figure 14. This figure shows that both groups had identical levels of variance on the operational pretest (the first scenario). The variance of the TAT group decreased with the subsequent scenarios and remained consistently low for the duration of the experiment, with the exception of scenario 9. The variance of the traditional group, in contrast, changed widely and was inconsistent across the series of scenarios. Furthermore, inspection of Figure 13 shows an

TABLE 5. EXPERIMENTAL PROCEDURE

Time *	Experimental Activity
5	A. Introduction and biographical sketch
10-15	B. Written pretest
5	C. Demonstrate Operational Display — Both control and treatment demonstration on functional equivalent of MK 81; explain data blocks, north up display, O/S maneuver limitations, etc.
10	D. Demonstration feedback display
	1. Control feedback
	a. PCD exceeds or does not exceed 50% levels of range of day predictions.
	b. I is achieved or not achieved.
	c. Qualitative IP information; equally weighted feedback summary of PCD and I performance feedback referenced to frozen operational display.
15	2. Treatment feedback
	a. LOS display (alternatives)
	Interrelate
	(1) AOB (Projected) and PCD
	(2) S <sub>o</sub> and PCD
	(3) C <sub>o</sub> and PCD
	(4) I and PCD
	(5) I and R
	(6) R and C <sub>o</sub>
	b. Graph display
	(1) Show PCD, I, and IQ
	(2) Show PCD as a function of: Proj. AOB, DMH <sub>o</sub> , C <sub>o</sub> , aspect
	(3) Show I as a function of SNR
	(4) Show PCD, I, and IQ
	E. Training Exercise (R OPER 2)
	Exercise #1
	Scenario (Pretest) 6 min/scenario
	Feedback
	Instruction
	Exercise #2
	Scenario
	Feedback
	Instruction
	.
	.
	.
	Exercise #10
	Scenario (Posttest)
	Feedback
	Instruction
	Treatment Feedback (each scenario)
	LOS (Diagnostic) - 3 min/scenario

\* Time estimate in minutes

TABLE 5. EXPERIMENTAL PROCEDURE (CON'T)

Time*	Experimental Activity
	3 graph (Analytic) - 7 min/scenario Hardcopy - 5 min/scenario Total Exercise Time/Treatment Subject = 3 hrs, 30 min Control Feedback (each scenario) Operational Display (Frozen) - 5 min/scenario Hardcopy - 5 min/scenario Total exercise time/control subject = 2 hrs, 40 minutes

F. Written posttest

\*Time estimate in minutes

		EXERCISES									
		1	2	3	4	5	6	7	8	9	10
TAT (EXPERIMENTAL)	S1	0.86	0.99	0.80	0.50	0.85	0.85	1.00	0.77	0.84	0.91
	S2	0.87	0.98	0.70	0.71	0.85	0.81	1.00	0.79	0.81	0.87
	S3	0.90	0.98	0.75	0.61	0.82	0.72	1.00	0.69	0.72	0.84
	S4	0.28	0.91	0.75	0.50	0.88	0.74	0.83	0.80	0.50	0.83
	S5	0.52	0.45	0.58	0.50	0.80	0.78	0.82	0.75	0.49	0.91
	S6	0.90	0.85	0.73	0.50	0.83	0.75	1.00	0.80	0.85	0.89
TRADITIONAL (CONTROL)	S7	0.86	0.12	0.60	0.50	0.79	0.67	0.95	0.77	0.50	0.65
	S8	0.42	0.50	0.56	0.50	0.65	0.40	0.85	0.66	0.50	0.85
	S9	0.94	0.97	0.88	0.61	0.95	0.87	0.99	0.90	0.94	0.94
	S10	0.37	0.50	0.63	0.50	0.09	0.67	0.88	0.14	0.50	0.80
	S11	0.43	0.94	0.73	0.50	0.78	0.69	0.93	0.83	0.50	0.91
	S12	0.41	0.12	0.15	0.49	0.58	0.59	0.85	0.65	0.50	0.86

Figure 13. Experimental Design Configuration, Listing the IP Performance Scores by Subject and Exercise

PERFORMANCE  
MEASURE  
(IP)  
VARIANCES

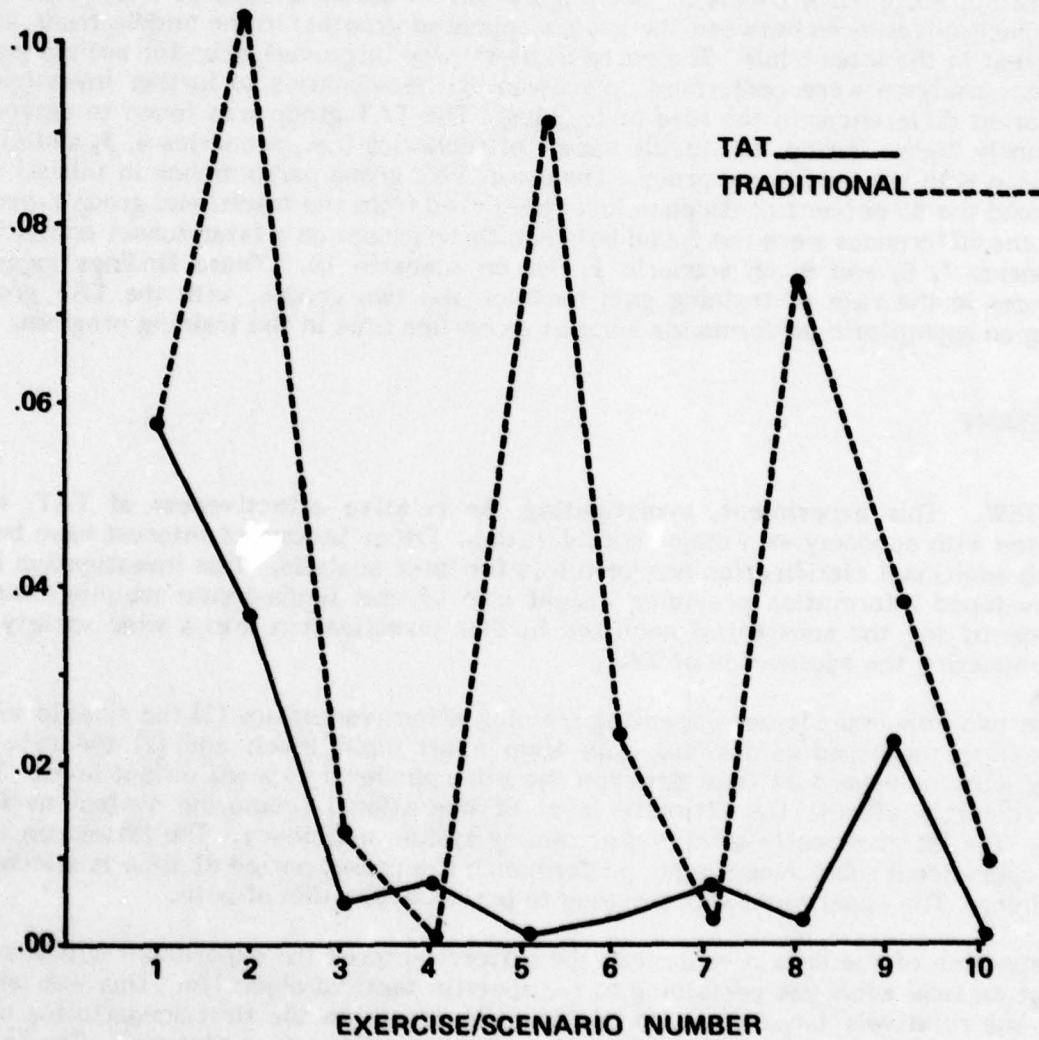

Figure 14. Experimental and Control Groups Graphs

apparently wide difference in the variances of the TAT and traditional groups in several of the scenarios, with the variance of the TAT group often lower.

The investigation of training gain was conducted by comparing the magnitude of the IP change from the operational pretest (scenario 1) to the operational posttest (scenario 10) for both groups. No significant difference was found in the overall training gain between TAT and traditional groups.

Several analyses were conducted to investigate differences in the rate of training gain. The mean IP performance on each scenario is plotted separately in Figure 15 for each group. This figure shows that the TAT group performed at a higher level on all of the scenarios. This observation was confirmed by the finding of a statistically significant difference in the overall mean IP performance between the groups' test results ( $Z:60, 60; = 2.73; p < .01$ ). See Figure 16. Figures 14 and 15 show that the performance differences between the groups appeared greatest in the middle trials, and not as great in the later trials. The early trials showed large variances for both groups. Statistical analyses were performed on subsets of the scenarios to further investigate the apparent differences in the rate of training. The TAT group was found to perform significantly higher during the middle subset of scenarios (i.e., scenarios 4, 5, and 6) in comparison with the traditional group. The mean TAT group performance in this subset was beyond the 95 percent confidence level predicted from the traditional group's mean. Significant differences were not found between these groups on a later subset consisting of scenarios 7, 8, and 9, on scenario 1, nor on scenario 10. These findings suggest differences in the rate of training gain between the two groups, with the TAT group reaching an asymptotic performance level at an earlier time in the training program.

## DISCUSSION

**OVERVIEW.** This experiment, investigating the relative effectiveness of TAT, was performed with economy as a major consideration. Other factors of interest have been omitted; additional clarification has been left for later analysis. This investigation has thus developed information providing insight into several fundamental training issues, while identifying the substantial need for further investigation into a wide variety of issues impacting the application of TAT.

The two important issues impacting training effectiveness are (1) the final level of performance, measured as training gain from a set input level; and (2) the rate of training gain, measured as time between the set input level to a set output level. The former directly affects the ultimate level of operational submarine system performance. The latter directly affects the training system efficiency. The latter can also affect operational submarine system performance if a preset period of time is allocated for training. The experiment was designed to permit evaluation of both.

Inspection of the data reveals that the officers entered the experiment with a wide range of tactical expertise pertaining to the specific tactical objective. This was borne out by the relatively large standard deviation in scores on the first scenario for both groups ( $S = 0.25$ ). This represents 50 percent of the possible range of scores. The range of scores actually obtained on the first scenario was between 0.28 and 0.94. Officers entering at the lower to middle range of scores could potentially receive substantial

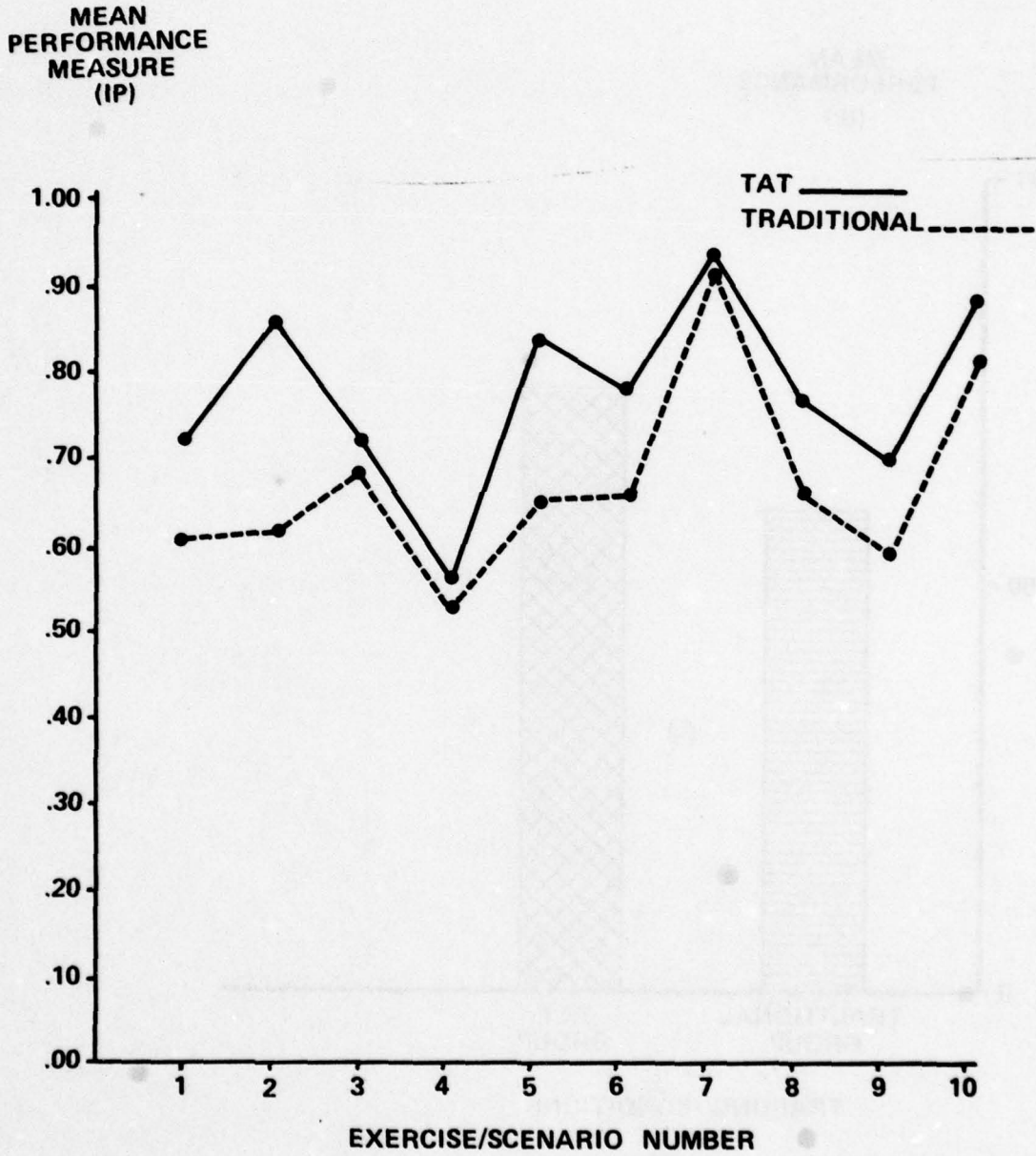

Figure 15. Mean IP Performance for TAT and Traditional Groups

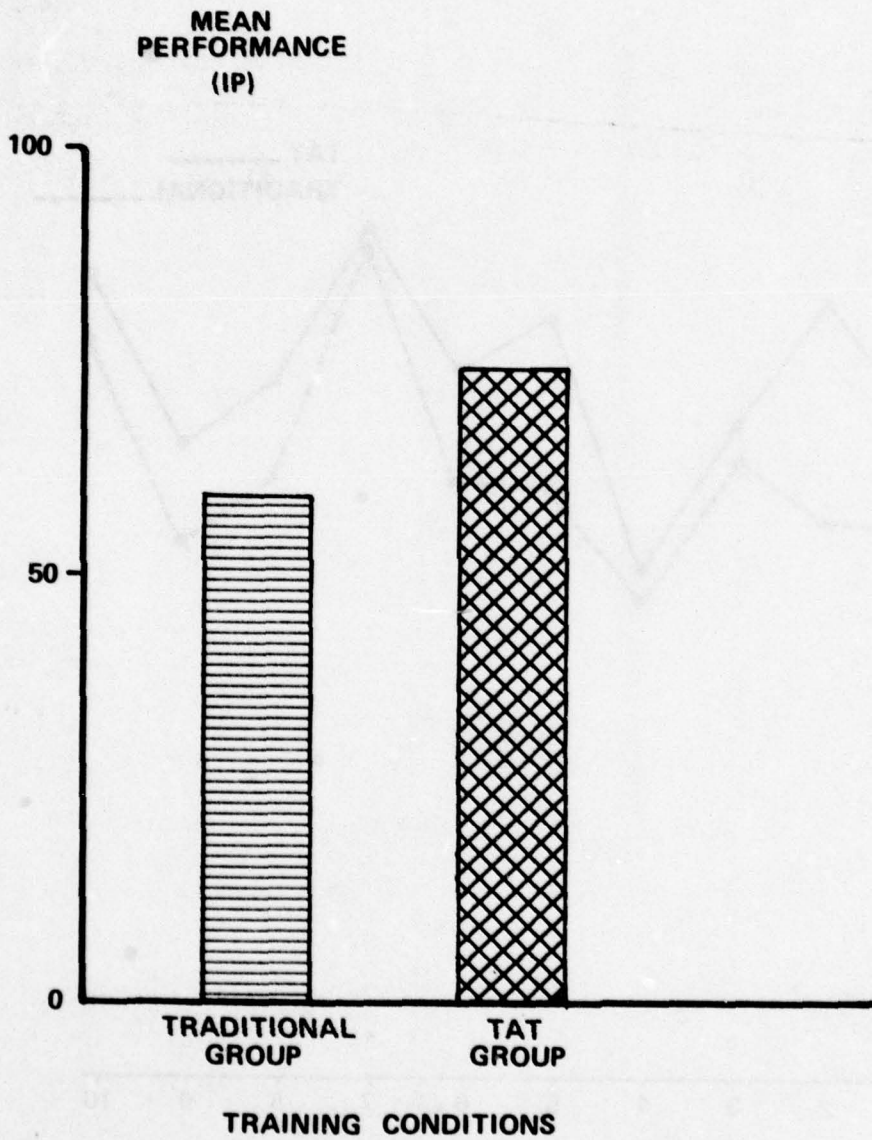

Figure 16. Overall Mean Performance

training benefit. Those officers entering at the upper range of scores precluded potential training gain. A more powerful, but less economical, approach would be to select trainees on the basis of their pretest score, thus eliminating those with high entering scores. This procedure would greatly reduce the trainee variance. Constraints during the experiment, however, necessitated the inclusion of all officers.

The geometrical scenario situation, as was expected, appeared to have an effect on performance, also contributing to the variance in the data. The scenario effects were not statistically analyzed, since their designs were not categorized, but can be observed from Figures 14 and 15. For example, the highest and lowest scores for both groups occurred in scenarios 4 and 7 respectively. Not only were the respective performance scores very close for both groups, but their variances were also small. Review of the scenarios confirmed the substantial effect of the respective similar tactical situation geometries. Scenarios 3 and 10 showed similar effects. The trend of scores across the training program (Figure 15) is strikingly similar for both groups, further substantiating the effect of the scenario situation. These observations point to the considerable operating constraints imposed by the tactical scenarios.

The TAT group was found to perform much more consistently than the traditional group, as evidenced by the Hartley homogeneity of variance test. This finding was unexpected. Its cause was not precisely determined. The most parsimonious explanation is based on the large entering performance variance between the officers in both groups. It is based on the fact that officers entering at a low proficiency level have a lot to gain, while those entering at a high level have little to gain from the training; and that the TAT process was apparently more effective than the traditional process in training those officers at the lower entering levels. Those officers at the lower range of input levels in the TAT group appear to have consistently improved during the first several exercises, rapidly reaching a level of performance equivalent to that of the officers at the high range of input levels, hence reducing the variance.

The TAT capabilities, therefore, appear to have provided the greater benefit to those individuals that had the greater need and potential. Those traditional group officers at the lower range of input level performance did not appear to benefit as rapidly or as consistently from the training. Perhaps they were unable to assimilate the various aspects of the tactical objective early in the program, requiring a piecemeal approach over a longer period of the training program. This explanation suggests that the TAT group performed more consistently as a result of rapidly elevating the performance of the subgroup entering at the lower proficiency levels. The rate of training gain is discussed in more detail below.

**TRAINING GAIN.** Both the TAT and traditional groups appear to have gained in tactical proficiency, as evidenced by the performance differences in the pre- and post-operational tests. Although the TAT group reached a higher level of average performance they did not show a training gain greater than that of the traditional group. This may be due to several factors. The most plausible explanation is that both groups reached a high level of tactical performance at or before the tenth scenario; and the traditional training approach was sufficient to achieve the maximum level of tactical proficiency in this task within the time allotted. Support for this explanation derives from the high input levels of proficiency exhibited by a large proportion of officers of both groups. The tactical objective selected was realistic to the point that

many officers were able to perform at a high level on the basis of the brief lecture preceding the first scenario. This explanation is consistent with the training program development approach, providing more than enough training rather than an insufficient amount.

Other factors are likely to also have affected the results. A factor causing some variance was the scenario situation, as noted earlier. A valid test of TAT training gain should be conducted under conditions which preclude the traditional group from performing at a high level. Only in this manner would the relative TAT/traditional differences in training gain be apparent.

**RATE OF TRAINING GAIN.** The training gain is often a misleading statistic since most training methodologies can achieve acceptable levels of training gain if given a sufficient amount of training time. Rather, the rate of training gain is the more important factor since it is based on the amount of gain over time. Both the TAT and traditional groups achieved a similarly high level of performance by the tenth trial. Both groups entered training at approximately the same level of performance. The TAT group, however, achieved significantly higher performance in the middle group of scenarios. The TAT group, therefore, exhibited a rate of training gain significantly higher than that of the traditional group. This finding is further supported by an apparently substantial reduction in TAT group performance variance by the third scenario. These results suggest that the TAT capabilities yielded a substantial training gain during the early exercises, resulting in the TAT group achieving their maximum performance level near the middle of the training program. The traditional group responded to the training at a slower rate, achieving their maximum performance near the end of the training program.

These findings demonstrate in a limited context that the TAT capabilities can enhance the effectiveness of the submarine tactics training process. An evaluation of the various training system characteristics, and their design regarding the TAT configuration, would likely result in greater training process enhancement. Characteristics requiring further investigation include:

- a. Display design with regard to fundamental man-display interaction and tactical training applications
- b. Training technologies used for the applied training of submarine officers
- c. Performance measures
- d. Mix of classroom and simulator time
- e. The training strategy (e.g., timing and use of displays and length of the training program)

These and other characteristics should be investigated with regard to the effective application of TAT capabilities in various training areas.

CONCLUSIONS AND RECOMMENDATIONS

The applied simulator-based training process is enhanced by the use of TAT capabilities. This conclusion is particularly warranted in the context of submarine officer tactics training. The TAT capabilities enhance the training process by reducing the amount of training time, thus increasing the number of officers who can be trained. Alternatively, TAT capabilities will allow additional training objectives to be achieved during the given training time. In either case, the addition of TAT capabilities will improve the efficiency of the training system.

It is recommended that the general TAT capabilities should be added to the existing tactics training simulators for both individual and team training. The general capabilities should be installed to enable the flexible design and modification of the TAT configuration. Furthermore, it is recommended that research be conducted to delineate the relative effectiveness of various TAT characteristics and configurations. This research should be designed to yield effective TAT configuration designs for application in submarine officer tactics training and other areas of training. The results of this research could be a major source of information for the specific implementation of the Submarine Advanced Reactive Tactical Training System (SMARTTS) program characteristics.

SECTION V  
CONCLUSIONS AND RECOMMENDATIONS

The conclusions and recommendations developed during Phase I pertain to the selection of the device and course for TAT experimental implementation, development of the training process, training model updates, TAT/21A37 interface, long-term research and development needs, and the applied laboratory investigation of TAT. Each of these areas is addressed below.

The selection of a device and course within which to implement and evaluate TAT at SUBSCOL was affected by several important considerations. These included the potential effectiveness of TAT, the installation and operational feasibility, and installation cost. The two primary training devices under consideration (i.e., 21A37 and 21B63) often differed widely on these characteristics, in such a way that there was no clear-cut choice. Either device would be acceptable and feasible for TAT evaluation. The 21A37, however, was recommended for the evaluation on the basis of its potentially greater benefits to tactics training; it is currently utilized notably more than the 21B63, and should be used extensively in the foreseeable future.

Several formal courses were found to be appropriate for the TAT evaluation. These are: (1) the Submarine Officers Advanced Course (SOAC), (2) the Prospective Executive Officers Course (PXO), and (3) the MK 113 Mod 10 Familiarization Course (FAM). Each of these courses addresses a variety of tactical issues at the intermediate to advanced level, and may employ the MK 81 tactics mode display. These courses will provide an appropriate context for TAT evaluation.

It is recommended that the TAT evaluation curriculum develop a common segment for SOAC and PXO courses. The MK 113 Mod 10 FAM course is not recommended, since it is taught only on the 21B63 Device, and does not use the 21A37 Device. However, since the development of the two courses is based on the similarity in the tactics portions of the curricula, a high degree of flexibility enables either course to be presented with minimal adjustments. This developmental approach has been followed.

The SOAC and PXO courses have similar training objectives and course material for those parts addressing tactics. The approach to training in each course is also similar, with greater emphasis on the FCC position in the former and on the AO position in the latter. Considerable overlap, however, does exist since both positions receive some training in each course. The TAT course segment was developed to be integrated with either course, addressing tactical issues directly pertinent to both the FCC and AO.

A variety of tactical issues were investigated with the selection based on the (1) potential effectiveness of TAT; (2) achievement of issues within the available time frame and MK 81 WCC training context; and (3) availability of training material. The issues selected pertain to (1) the deployment/maneuvering of own ship with regard to TMA, and (2) closing the target to a position of tactical advantage. These issues may present a difficult tactical decision-making problem to the approach officer, assistant

approach officer, and fire control coordinator. Three training objectives were developed from these issues:

- a. Recognize the effects of the mission objectives in constraining the values of closing rate, solution accuracy, and probability of counterdetection
- b. Understand the "optimum geometry" concept (optimum maneuver recommendations relative to solution accuracy, closing rate, and PCD tradeoffs)
- c. Recognize the potential impact own ship maneuvers have on probability of counterdetection, target bearing error, signal-to-noise ratio, and bearing localization accuracy

These training objectives are the basis for which the curriculum segment was developed.

The TAT evaluation at SUBSCOL will be accomplished by monitoring TAT capabilities during training. This open-ended approach will evaluate available data, and allow a high degree of flexibility during training. The constraints of a rigorous experiment will not be imposed. This approach is most amenable to training on the 21A37 Device in a team context. The training emphasis during the TAT-based segment will be on the AO, AAO, and FCC positions, consistent with present SOAC and PXO practices. All trainees rotate through all the positions receiving relevant feedback regarding the position they may be occupying at the time.

A modular training course segment is recommended, consisting of five modules to achieve the training objectives: (1) initial TMA, (2) TMA maneuvers, (3) closing rate, (4) optimum geometry, and (5) probability of counterdetection. Each module addresses distinct aspects of the TMA/closing problem, addressing tradeoffs between TMA and closing. A complicating factor, in the form of probability of counterdetection, affecting both TMA and closing tactics, is also addressed. Seven exercises were developed comprising the five modules. The exercises were developed to use the TAT capabilities, including diagnostic feedback displays, alternative tactics generation, and performance measures. The exercises/modules will comprise 8 to 10 hours of tactics training.

Several performance measures, both primary and secondary, were deemed necessary to support the training process. The primary measures were developed specifically for the TAT course segment and directly pertain to the objectives of the training process. They include part-task and summary measures. The part-task measures will be used to evaluate aspects of performance during the training process including: (1) closing rate, (2) time to station, (3) solution accuracy, and (4) probability of counterdetection. The summary measure will be used to evaluate overall performance; appropriately, it is the quality of approach. Detailed algorithms have been developed and recommended for each primary measure. The secondary measures include available tactical parameters, such as signal-to-noise ratio, that are relevant to aspects of performance and are used to investigate performance.

The training exercises focus on own ship actions and the system TMA solution. The operational MK 81 WCC displays and other fire control system hardware/software are sufficient to support these requirements. Two diagnostic feedback displays have been

NAVTRAEQUIPCEN 77-C-0107-1

recommended to provide assistance. These are the general purpose graphing display and the line-of-sight display. A modified version of the previously designed general purpose graphing display is recommended. The line-of-sight display was specifically developed for these exercises. One version of this display is recommended for investigating alternative own ship actions. The other version is recommended for investigation of speed-across-the-line-of-sight matching. These displays are differentially recommended for use during the exercises.

A research and development plan was developed recommending three levels of investigation: fundamental, applied, and operational implementation. Investigations should proceed from the fundamental to the operational implementation. Twelve specific areas were identified as most important, encompassing a wide variety of current tactics training research and development needs. Each of these areas was assigned to one or more of the levels. The priority of research needs was established via ranking of the twelve areas. Investigation of feedback display characteristics was recommended as the primary area for investigation; a detailed experiment was designed to investigate several relevant issues. Finally, a schedule was developed recommending the time frame for initiation and conduct of research.

The applied laboratory investigation of TAT was conducted successfully with experienced naval submarine officers. The TAT-assisted training process was superior to the traditional training process. The training time to reach the criterion level of performance was less for the TAT group. It is recommended that TAT capabilities be added to the existing tactics trainers, and be included in all future devices. It is furthermore recommended that research be conducted to delineate the effectiveness of various TAT characteristics and configurations, pertaining to submarine tactics training and areas of training in general.

REFERENCES

Callan, J.R., Kelly, R.T., and Nicotra, A., Measuring Submarine Approach Officer Performance on the 21A40 Trainer: Instrumentation and Preliminary Results, Navy Personnel Research and Development Center, NPRDC TR 78-9, 1978.

Downie, N.M., and Starry, A.R., Descriptive and Inferential Statistics, New York, Harper and Row, Publishers, 1977.

Hammell, T.J. Gasteyer, G.E., and Pesch, A.J., Advanced Officer Tactics Training Device Needs and Performance Measurement Technique, Technical Report NAVTRADEVCEEN 72-C-0053-1, General Dynamics, Electric Boat Division, Groton, Connecticut, Volume I, 1973.

Hammell, T.J., Pesch, A.J., Ewalt, F.M., and Rabe, P.L., Prototype Tactical Decision-Making System - Device Summary, Technical Report NAVTRAEQUIPCEN 75-C-0078-01, Naval Training Equipment Center, Orlando, Florida, February 1976.

Hammell, T.J., Sroka, F.P., and Allen, F.L., A Study of Training Device Needs for Meeting Basic Officer Tactics Training Requirements, NAVTRAEQUIPCEN 69-C-01401, Naval Training Equipment Center, Orlando, Florida, March 1971.

Pesch, A.J., Hammell, T.J., and Ewalt, F.M., Tactical Decision-Making Training System Design, Technical Report NAVTRAEQUIPCEN 73-C-0158-1, Naval Training Equipment Center, Orlando, Florida, November 1974.

Record/Playback System Report TS-02 for Submarine Combat System Training Device 21A37/4, Report 8355-202, Singer-Link Division, May 1978.

Sidorsky, R.C., and Simoneau, G., Decision Making Study Final Report I. An Experimental Evaluation of TACTRAIN: An Approach to Computer Aided Tactical Decision Making Training, NAVTRADEVCEEN Rpt 1329-4, Naval Training Device Center, Orlando, Florida, March 1970.

Siegel, S., Nonparametric Statistics for the Behavioral Sciences, New York, Mc-Graw-Hill Book Company, 1956.

Winer, B.J. Statistical Principles in Experimental Design, New York, McGraw-Hill Book Company, 1971.

APPENDIX A

DESCRIPTION OF SUBMARINE TACTICS TRAINING COURSES

1. Submarine Officer's Advanced Course (SOAC)
  - a. Trainees — Individual submarine officers from different ships, OOD trained, qualified, and generally at the lieutenant level (occasionally LCDR). They are trained tactically in a team context to the Fire Control Coordinator (FCC) level. This is the training goal for the weapons/tactics portion of the SOAC course. Many officers are able to perform at the AAO/FCC level on course completion. Officers may come from SS, SSN, or SSBNs and be assigned to such on completion.
  - b. Curriculum
    - (1) 21A37 — Attack center training is directed toward group instruction of individuals in submarine tactics using passive sonar information. Attack center scenarios are normally one-on-one interactions to develop FCC skills and knowledges. AC 4 is employed for about one-third of the total course time with the 21A37, the remaining time using AC 2 and AC 3. AC 4 provides the officer with learning experiences in the integration of tactical information from the MK 81 analyzer within the submarine interaction. The other 21A37 attack centers provide training experience for SOAC trainees on the MK 113 FCS, Mods 8 (AC 3), 9 (AC 2), and 10 (AC 4). Officers with through orders to a MK 113/10 SSN can get limited extra instruction regarding the MK 81 WCC on an individual basis in AC 4 or the 21B63.
    - (2) 21B63 — Lab training time is provided to familiarize trainees with the basic (knobs and dials) operation of the MK 81 Weapon Control Console. About one-third of the total 21B63 average of about 20 hours per SOAC course is spent in the computer-assisted training (CAT) exercise training mode. The remainder is used for basic TMA (i.e., KAST, Bearing Edit, and MATE) use of the MK 81 with dynamic exercise (DE) mode. Trainees typically use the prestored DE exercises and do not normally CONN own ship in a free play or advanced tactics operations situation. The training is usually limited to one or two DE exercises to familiarize the trainee with the MK 81 WCC's purpose in a MK 113/10 or MK 117 FCS.
2. Prospective Executive Officer Course (PXO)
  - a. Trainees — Trainees for this course are individual LCDRs, submarine qualified. They are provided tactics training to the level of AO (encompassing FCC training). Training is geared toward fire control systems to which these trainees are likely to be assigned. Training is also provided based on the trainees' requests (e.g., a trainee whose future assignment is to a MK 113/10 FCS may request additional training time on the 21B63).

## NAVTRAEQUIPCEN 77-C-0107-1

- b. Curriculum — Curriculum is oriented toward advanced tactics training. Weapon employment, KILO tactics, special operations (e.g., TUBA), etc, are covered. This course utilizes the same training devices as the SOAC curriculum (described in the previous SOAC course description). The curriculum is an advanced version of the tactics covered in SOAC. The primary SOAC/PXO course differences are those of instructional emphasis (e.g., both courses use the same trainee guides). Also in comparison with SOAC, PXO has a greater degree of flexibility in the areas of concentration based on tactics training using dynamic exercises provided in the device instructor's manual (with instructor contrived variations).
3. Prospective Commanding Officer Course (PCO)
    - a. Trainees — Individual, qualified submarine officers, at the CDR level. Occasionally, a PCO trainee may be a senior LCDR. (Furthermore, each officer has been designated for command of a submarine. They are trained in tactics for the Approach Officer level. Training includes classroom, 21A37 Device time, and actual underwater experience on selected SSNs (as available). PCOs receive some tailored training directed toward the type of fire control system most likely on the SS, SSN, or SSBN of which they will take command.
    - b. Curriculum
      - (1) 21A37 SCST time is evenly distributed across all the current MK 113 attack centers. The emphasis in the attack centers is on developing Approach Officer skills, rather than the introduction into special capabilities of individual fire control hardware. That type of tactical information is given in classroom lectures and lab walk-throughs. All the current attack center sessions now scheduled for PCOs at SUBSCOL are oriented toward objectives in advanced tactics (e.g., weapons firing, KILO runs, TUBA). This training is group instruction of individuals.
      - (2) 21B63 — No PCO curriculum exists for use of this device. PCOs who are scheduled to go aboard MK 113/10 or MK 117 submarines occasionally go to the 21B63 Device for basic indoctrination on the MK 81 WCC. Records show that several PCOs have used this lab for an average of 2 hours each. All training indicated in the records was of the familiarization type with CAT and DE exercises to demonstrate the MK 81 capabilities. This may be classified as knobs and dials plus basic tactics TMA. Insufficient time is provided to give the trainees an in-depth appreciation of the MK 81 WCC capabilities in command/control problem solving.
4. MK 113/10 Familiarization
    - a. Trainees — Individuals, submarine junior officers, both submarine qualified and unqualified, and senior enlisted (FTG1 and FTGC primarily). The officers are at the LT/LTJG level. All trainees can be expected to come from SSNs with MK 113/10 or MK 117 FCS.

**b. Curriculum**

- (1) **Basic MK 81 Analyzer Operator** — The objective of the course is to train individuals in the shipboard tasks of the MK 81 operator. This includes TMA functions, KAST, KAST EDIT, MATE, Bearing Edit, etc. Basic tactics are covered in operation of EDE displays and Geosit displays. The course use of the 21B63 is approximately as follows:
  - (a) 60 percent procedural training (knobs and dials) — Functional equipment operation using the CAT and DE functions of the 21B63 training program. Objectives of training are in manipulation of encoders, keyboards, etc.
  - (b) 40 percent basic tactics — Tactical MK 81 employment. Training employs DE function of 21B63 training program, and training mode of MK 113/10 SSN688 operational program. Training is mostly concentrated in the area of TMA, with KAST, Background KAST, KAST Editing, MATE and Bearing Editing exercises provided. A small percentage of device time (less than 10 percent) will cover tactics at the sonar approach level using the MK 81 geosit displays.

**5. REFTRA/PREDEPLOYMENT**

- a. **Trainees** — The purpose of the refresher/predeployment training is to improve individual and team performance as a result of training in the team context. The trainee population is the fire control party from a specific submarine. The trainee positions in the team are fixed throughout the tactical problems presented in the attack center session. The FCC, for example, will be the same individual throughout the session. This can be contrasted with SOAC training, where trainees rotate through the various operator positions of FCC, plot coordinator, MK 81 operator, etc, from one problem to another. These refresher and predeployment training courses are for SSN crews.
- b. **Curriculum** — The curriculum for these courses varies based on both training emphasis requests from the trainee command and on intelligence information concerning potential tactical encounters for a given operational area. Trainee commands can select the training emphasis from a list of topic objectives supplied by SUBSCOL. Typically, trainees received between 20 and 30 hours of team tactics training. This training will use AC 4 (MK 113/10 UFCS, MK 81) as more submarines are equipped with the FCS. Team training is now conducted primarily in AC 3 (MK 113/8 UFCS). The tactical hardware in this attack center is representative of the SSN637 class submarine fire control system. If a submarine crew employs a MK 113/10 or MK 117 UFCS, they would receive team training in AC 4 or individualized operator training on the 21B63 Trainer. Individual training (up to 15 hours), which would be conducted on the 21B63 Device, is provided to trainees who require procedural training prior to MK 81 operation in the team setting.

APPENDIX B  
TRAINING DEVICE CHARACTERISTICS

This appendix contains a description of the two training devices, 21A37 and 21B63 (MK 113/10 UFCS), which were candidates for TAT implementation. The 21A37 Device has a number of variations representing different UFCS Mods. A functional description of the devices follows.

21A37. The 21A37 Submarine Combat Systems Trainer is configured for four attack centers (ACs), three of which are currently operating. AC 2 simulates the MK 113/9, AC 3 the MK 113/8 and AC 4 and MK 113/10. AC 1 is a future installation planned for the MK 117 FCS. All ACs may be independently operated, with targets and own ship controlled in course, speed, and depth. Each AC represents an individual own ship, provided with bearing information simulating passive sonar contact on from one to six targets. Bearing and tracking data are simulated on the basis of an ocean model and target SNR. AC 3 is also equipped with a single periscope, providing the capability for one to six visual targets based on the target tactical parameters (i.e., course, speed, and depth). The 21A37 will support a wide variety of tactical operations. Between the various ACs, the trainees can receive training experience from simulated weapon firings for all current submarine tactical weapons, against all current threats. In addition, special mission exercises such as TUBA/KILO can also be simulated. The 21A37 does not provide automated spontaneous target reactions (i.e., knowledgeable opponent capabilities). Counterdetection, counteractions, and counterattacks by the target must be simulated by the off-stage controller. The 21A37 does have the capability for scenario control in an AC versus AC mode, using any two of the three software-linked ACs against each other. The 21A37 has a FREEZE capability to halt any problem for appropriate discussion. There is also a replay capability but this cannot be used to pick up and pursue alternate outcomes or tactics. These require new scenarios. (Note: AC 4 has only one MK 81 Analyzer Console.)

21B63. The 21B63 Generalized Individual Fire Control Operator Trainer Device has three MK 81 weapons control consoles. One console is designated the master COTD. This console serves as the instructor console, the remaining two consoles are available for training (primarily TMA, i.e., MATE/KAST and EDE).

Two modes of training are supportable with the 21B63 training software simulation program (to be distinguished from the MK 113/10 operational training program, to be discussed later). The first mode, the computer-assisted training mode (CAT), provides a preprogrammed frame-by-frame training scenario (distinct from a continuous tactical scenario) with an accompanying audio narrative describing the displayed frames. The narrative is presented to the trainee through a headset. The CAT exercise is essentially a tutorial mode.

The CAT exercises are stored frames generated from the second mode of 21B63 operation, the dynamic exercise (DE) mode. The DE mode uses a simulation program based on the MK 113/10 fire control program. The DE provides a tactical scenario with own ship and target parameters under instructor real-time control from the designated

NAVTRAEQUIPCEN 77-C-0107-1

MK 81 instructor console. This mode has both freeze (for immediate feedback) and replay capabilities (for delayed feedback, i.e., postproblem critique). DE automatic replay is frame by frame either real-time, twice real time, or very fast time. A manual DE replay is available which permits a frame-by-frame critique advancing under the instructor's control. The DE permits discussion of alternatives (e.g., own ship maneuvers) during a problem freeze, but this mode does not support the generation of alternative maneuvers during the scenario run or replay conditions. The DE mode only supports a once-through scenario run and replay. A zero problem capability permits a problem restart to initial parameters only.

The main use of DE is for TMA training (i.e., MATE, KAST, and Bearing Edit). This includes KAST editing, background KAST and KAST restarts.

Both the CAT and DE modes supported by the 21B63 training simulation program have a single maneuverable own ship and from one to eight maneuverable targets.  $L_s$  is also under instructor control as it contributes to solution quality versus TMA analysis time. Maneuvers, both target and own ship, can be prestored and can be modified in real time (problem run).

The MK 81 (MK 113/10 FCS) regular at-sea operational program, as used on SSN686/687, can also support 21B63 training in that program's training mode. In the operational program mode, no target inputs, or own ship control are available. In the operational program training mode, own ship and targets are controlled as in the 21B63 training program, but there are no prestored maneuvers. No replay, no Weapons Attack Evaluation (WATE), and no pseudo torpedoes are available. Only a TARGET HALT and problem restart at the halt point are available.

Gross measures of trainee performance are available in terms of computed accuracies of the system solution and results of weapon firings.

The 21B63 is not interfaced with the 21A37 computer complex. The 21B63 is a generalized stand-alone MK 81 COTD trainer.

APPENDIX C  
INTERFACE DISCUSSION

21A37 HARDWARE OVERVIEW

The information regarding the 21A37 SCST was obtained from (1) discussions with naval personnel, (2) discussions with 21A37 SCST contractor support personnel, and (3) the record playback system report. The computer system used in the 21A37 Training System at the Naval Submarine School, Groton, is shown in Figure C-1. It consists of two UNIVAC AN/UYK-7 central processors and a Digital Equipment Corporation PDP-11/35 processor. The two AN/UYK-7 processors share a memory bank, with each processor providing simulation for two attack centers. The PDP-11/35 serves as an input/output processor for the AN/UYK-7s, controlling information to/from disk storage mediums and other peripheral devices.

PDP-11/35 SYSTEM. The PDP-11/35 system:

- a. Supplies attack center display formats (instructor's consoles, etc)
- b. Generates initial setup acoustic data and signature noise and reverberation for the simulations
- c. Provides sound velocity profile data and updates the information from its ocean data base
- d. Provides methods to generate new ocean data bases
- e. Sets up all the initialization parameters for each attack center problem
- f. Manages problem resets from each attack center as well as overall system resets
- g. Records data from each attack center pertaining to own ship, target, TMA, and other situational factors
- h. Provides the playback mode so that each attack center's training exercise can be analyzed after the fact
- i. Stores the core image AN/UYK-7 programs and footstraps these machines via the Naval Tactical Data System (NTDS) channel

AN/UYK-7 SYSTEM. The AN/UYK-7 system:

- a. Performs all the own ship, target, weapons, and fire control calculations
- b. Regulates all the display controls and indicators in each attack center, including the instructor console
- c. Provides the information to the PDP-11 for recording the training exercise
- d. Receives playback information from the PDP-11 system and drive all displays and indicators for after-the-fact analysis of training exercises via the instructors console
- e. Compiles and assembles its own programs utilizing the PDP-11/35 system as the mass storage device

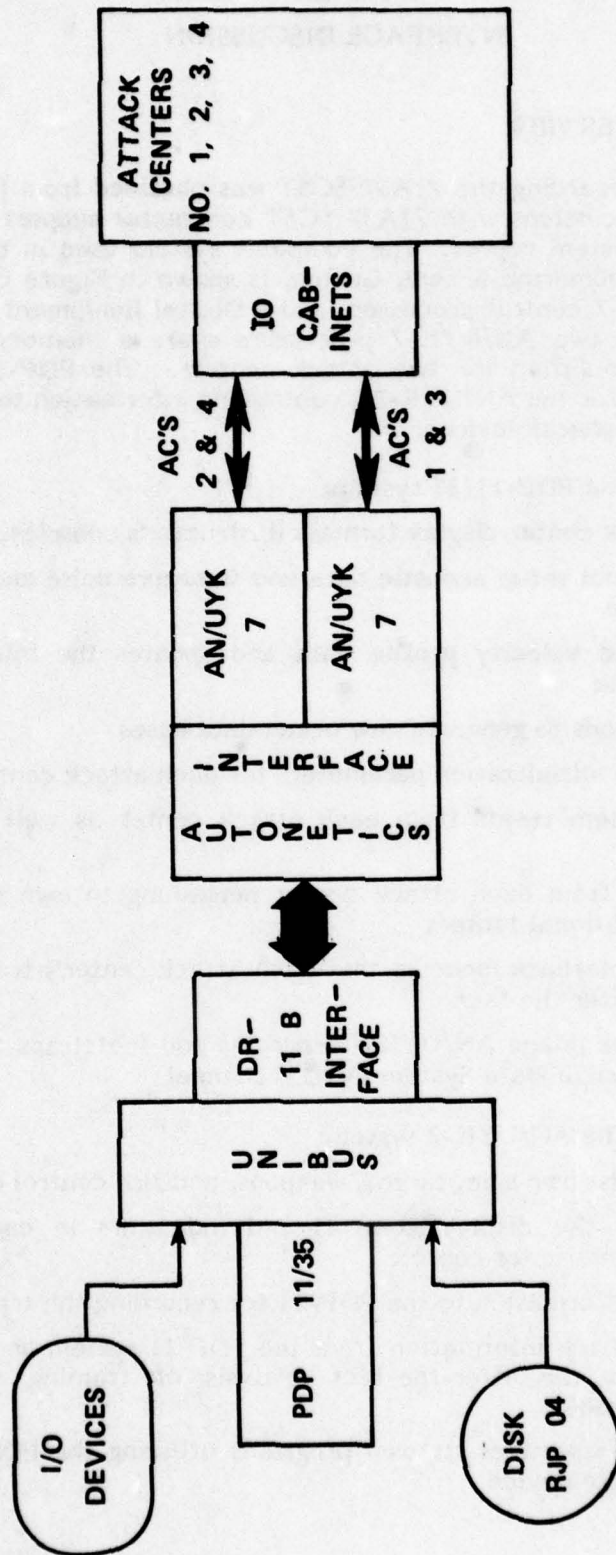

Figure C-1. Simplified Computer System Breakdown

## NAVTRAEQUIPCEN 77-C-0107-1

Detailed block diagrams for each of the computer systems are shown in Figures C-2 and C-3. Figure C-2 illustrates the PDP-11/35 system which functions primarily as an input/output controller (IOC). The Autonetics interface between the DEC DR 11B interface and the AN/UYK-7 is also shown. Figure C-3 illustrates the AN/UYK-7 system configuration. It has a 160K word memory bank shared by both AN/UYK-7 processors. Each processor has an IOC containing 16 channels. The channel assignments for each IOC are listed in Table C-1. Ten of the 32 input/output (I/O) channels are currently neither used, nor have a planned use. The I/O channels operate in the NTDS FAST configuration (logic levels of 0 VDC to -15 VDC).

### 21A37 SOFTWARE OVERVIEW

AN/UYK-7. The AN/UYK-7s run core-resident trainer applications code is under control of a core-resident multitasking execute program. The multitasking execute program was specifically written by Singer-Link for the 21A37/4 SCST. The majority of the execute code is written in MACRO assembler. The core-resident training applications code consists of (1) program modules which apply to the different equipments located in each attack center (e.g., MK 81 WCC), and (2) simulation modules needed to create data which are not available on a shore-based facility (e.g., target noise level). These application modules consist of:

- a. Timing module — provides clock
- b. Sonar and acoustics models module — provides target signature and level information
- c. Own and target ship motion module — moves the ships around according to prescribed tactics
- d. MK 81 display generator and monitor module — controls the MK 81 WCC displays, responds to display changes, and updates information or display
- e. Weapons simulator and monitor module — keeps track of firings and moves weapons around
- f. Periscope monitor module — keeps track of periscope data and events
- g. Fire control models module — generates TMA data for own ship fire control system
- h. Position keeper monitor module
- i. Central Processing Unit (CPU) "B" intercommunications module
- j. PDP-11/35 data transfer module
- k. 1532 console TTY module
- l. Instructors console displays updates module
- m. Interrupt and events module

A large portion of this code is written in MACRO assembler with some of it written in CMS-2.

NAVTRAEQUIPCEN 77-C-0107-1

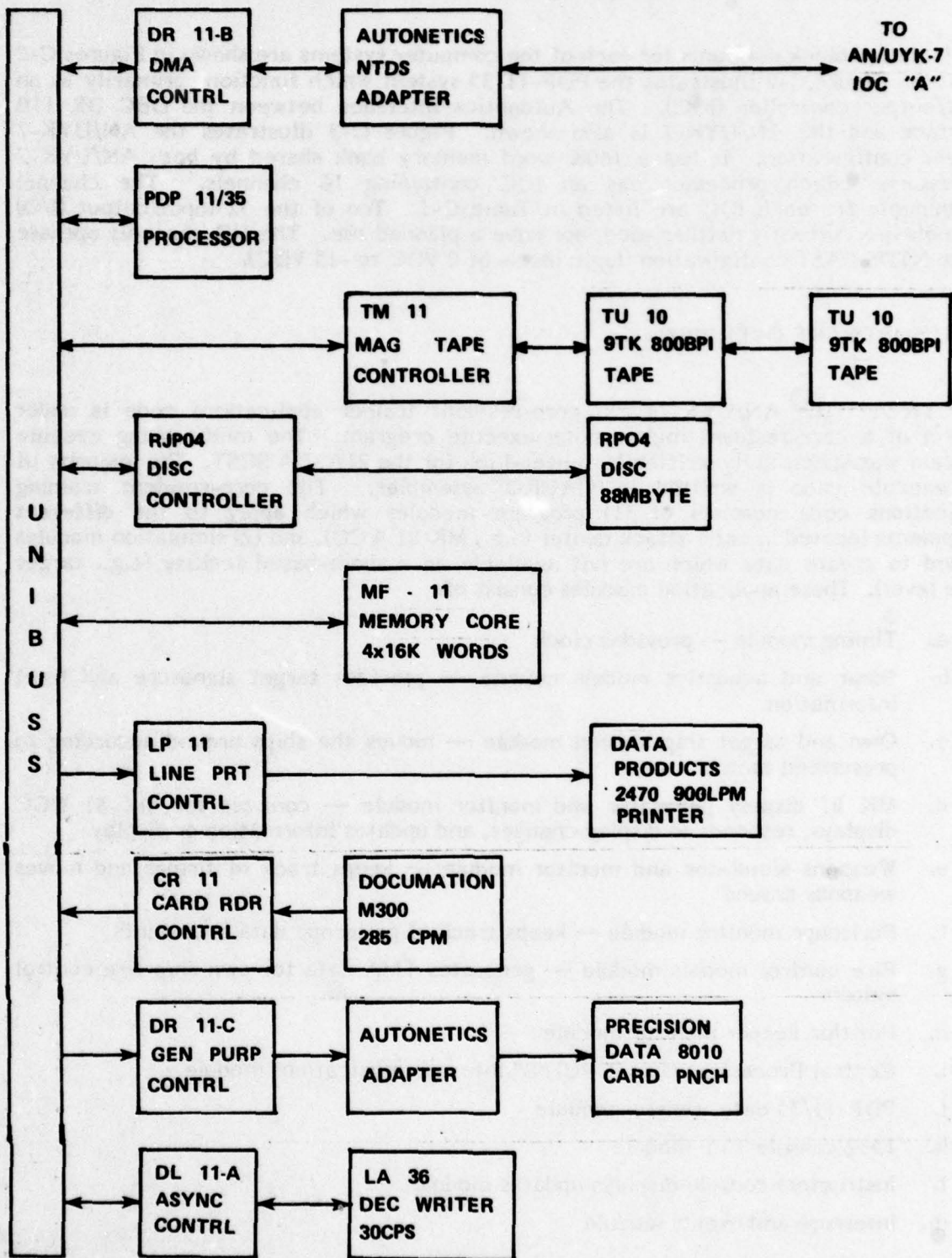
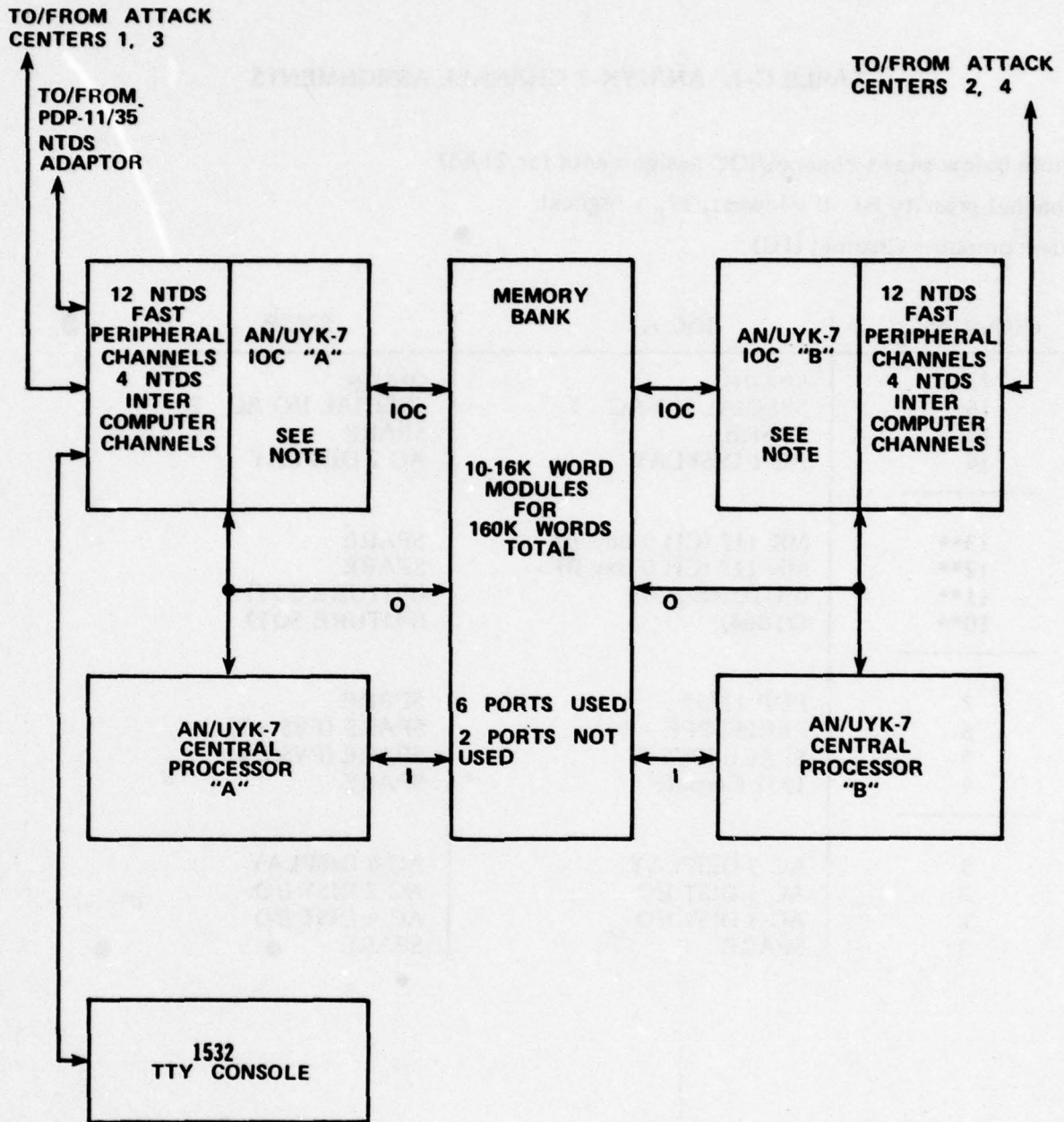

Figure C-2. PDP-11/35 System



NOTE: See TABLE 5 for IOC A and B channel assignments

Figure C-3. AN/UYK-7 System

NAVTRAEQUIPCEN 77-C-0107-1

TABLE C-1. AN/UYK-7 CHANNEL ASSIGNMENTS

Table below shows channel/IOC assignments for 21A37

Channel priority is: 0 = lowest, 17<sub>g</sub> = highest

Intercomputer Channel (IC)

CHAN. No. <sub>g</sub>	IOC A	IOC B
17	SPARE	SPARE
16	SPECIAL I/O AC 3	SPECIAL I/O AC 2
15	SPARE	SPARE
14	AC 1 DISPLAY	AC 2 DISPLAY
-----		
13**	MK 117 (CH 0 Bay A)	SPARE
12**	MK 117 (CH 0 Bay B)	SPARE
11**	(FUTURE SOT)	(FUTURE SOT)
10**	(21B64)	(FUTURE SOT)
-----		
7	PDP 11/35	SPARE
6	PERISCOPE - 3	SPARE (PVS = 2)
5	SPARE (PVS 1)	SPARE (PVS = 4)
4	1532 Console	SPARE
-----		
3	AC 3 DISPLAY	AC 4 DISPLAY
2	AC 1 DIST I/O	AC 2 DIST I/O
1	AC 3 DIST I/O	AC 4 DIST I/O
0	SPARE	SPARE

## NAVTRAEQUIPCEN 77-C-0107-1

The execution of each of these modules is under control of the multitasking executive. The executive is in turn driven by (1) attack center events (i.e., button is pushed, weapon fired), (2) simulation results (i.e., target detected, target hit), (3) CPU "B" wants CPU "A" to do something for it (transfer data block to/from PDP-11, etc), (4) PDP-11 wants CPU "A"s attention and (5) the time. These modules are shown in Figure C-4. These task items appear as flags in the executive's task queue, and also as hardware interrupts to CPU "A".

The order in which CPU "A" operates (i.e., task priority) is determined at the time the system software and hardware is put together. Software tasks that handle rapidly changing data and/or control and/or have time constraints, are assigned higher priority than a task which handles slowly varying data and/or does not occur very often and/or has no time constraints. For instance, the sonar/acoustics module has a higher priority than the periscope module. It should be noted that task priority is not absolute but is determined by the events happening at a particular time. Tasks may be "bumped" up or down in priority depending on the running configuration. Hardware priority is established in a similar manner with high data rate devices and/or devices with real time constraints having higher priority than slower devices and/or little real time constraints. Hardware priority, once set, can only be changed by physically moving wires or changing switches; it is not dynamic.

Data movement between the different applications modules is accomplished by setting up data buffer areas in core which do not move and can be referenced and/or changed by each of the applications modules as required. This means that any module has access to any or all of the data used by all other modules. Since the CPU "A" handles two attack centers (1 and 3), the data buffers required for each attack center are located in different areas of core. A task "crunching" on data for attack center 1 can only reference the attack center 1 data buffers. This is true for attack center 3.

CPU "B" uses the same core memory bank that CPU "A" has access to; CPU "A" and CPU "B" share the use of main core memory. CPU "D" is also under control of the multitasking executive in the same manner as CPU "A", and has the same tasks to accomplish. The only differences are that CPU "B" does not handle the PDP-11 data transfer module or the 1532 console TTY module, and the intercommunications module is now for CPU "A". The other functions discussed for CPU "A" also apply to CPU "B" with the exception that CPU "B" runs attack centers 2 and 4. Since each CPU requires the same applications modules they can be the same in core module with the data buffers for each CPU and each attack center located in different places in core. An actual core load map is shown in Figure C-5.

Since each attack center is configured differently, the application modules are written to apply to all attack centers in general. Input parameters that are transferred from each attack center's data buffer to the applications module specify the appropriate parameter for the module to accomplish attack center x's calculations. The same is true for most of the multitasking executive required by both CPUs. They execute the same in core code with separate CPU "A" and "B" data areas.

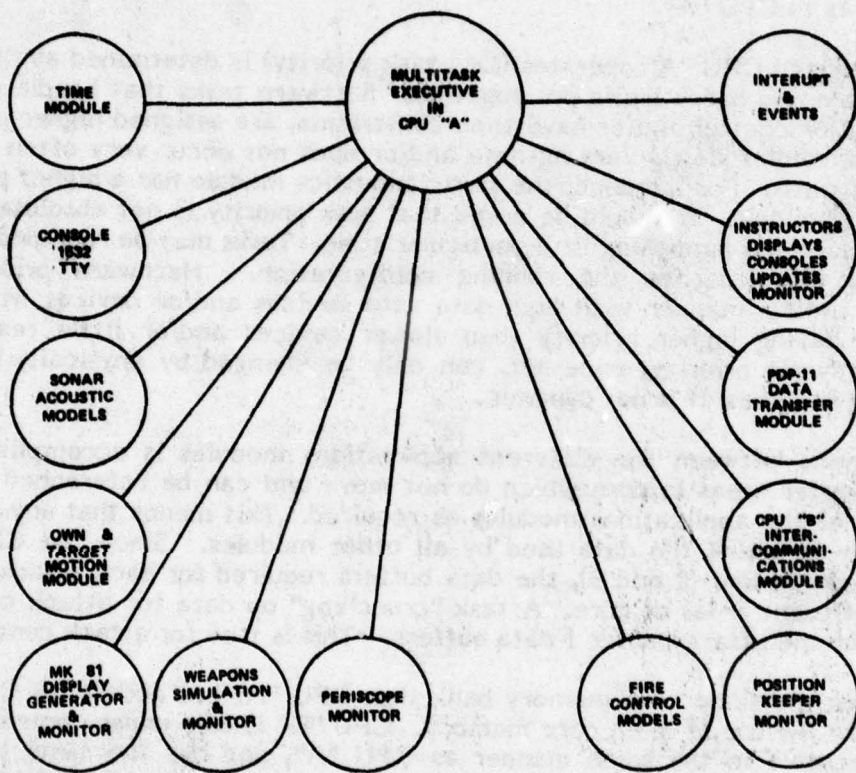

Figure C-4. Executive Control Execution of all Applications Models

NAVTRAEQUIPCEN 77-C-0107-1

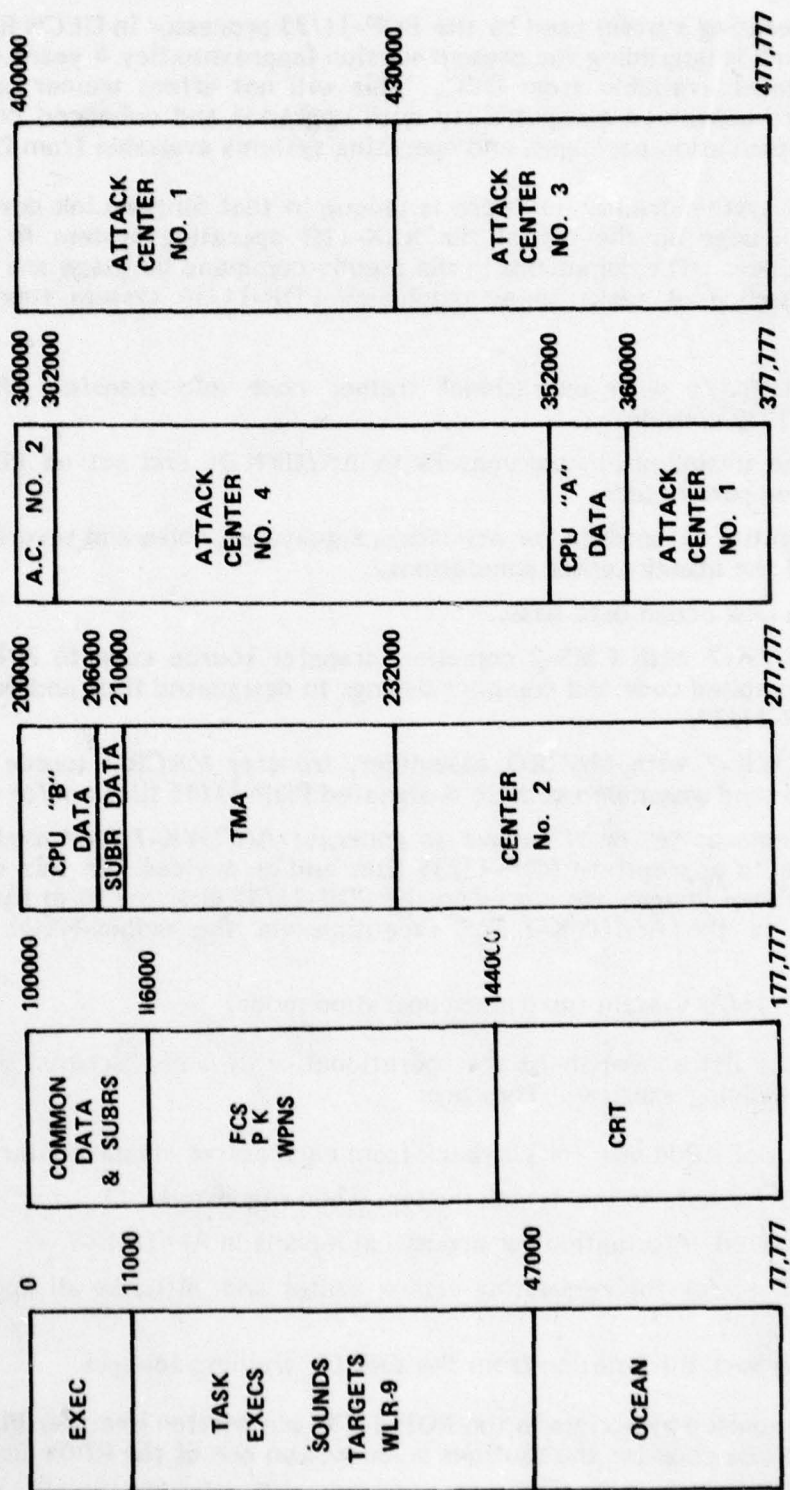

Figure C-5. An AN/JYK-7 Core Load Map for 21A37/4

## NAVTRAEQUIPCEN 77-C-0107-1

PDP-11/35. The operating system used by the PDP-11/35 processor in DEC's RSX-11D. At present Singer-Link is upgrading the present version (approximately 4 years old) with the latest release level available from DEC. This will not affect trainer operation. Rather it will ensure continued compatibility with upgraded and enhanced compilers, utilities, libraries, application packages, and operating systems available from DEC.

The PDP-11/35 system trainer software is unique in that Singer-Link developed a pseudo-command language on the top of the RSX-11D operating system to simplify operation of the trainer. The commands in the pseudo-command language are "scripts" which invoke a sequence of tasks to accomplish PDP-11/35 system functions as described below:

- a. Load AN/UYK-7s with operational trainer code and transfer AN/UYK-7 control to 1532 console.
- b. Pass all the initialization parameters to AN/UYK-7s and set up PDP-11/35 initialization parameters.
- c. Generate initial setup data for acoustics, signatures, noise and reverberations for each of the attack center simulations.
- d. Generate a new ocean data base.
- e. Load AN/UYK-7 with CMS-2 compiler, transfer source code to AN/UYK-7, and send compiled code and compiler listings to designated files and/or devices on the PDP-11/35.
- f. Load AN/UYK-7 with MACRO assembler, transfer MACRO source code to UYK-7 and send assembled code to designated PDP-11/35 files and/or devices.
- g. Function same as "e" or "f" above to generate AN/UYK-7 load modules and send output to appropriate PDP-11/35 files and/or devices. In this case, the executable load images are stored on the PDP-11/35 disk in a form that can be sent back to the AN/UYK-7 for execution via the unibus-NTDS channel interface.
- h. Set up PDP-11/35 system for trainer operation mode.

In addition to the list above, there are operational or dynamic "scripts" which are involved during the training exercise. They are:

- a. Record data of RP04 disk for playback from each active attack center
- b. Supply CRT formats to the attack centers when requested
- c. Provide updated information for acoustical models in AN/UYK-7
- d. Reset problem for the requesting attack center and initialize all appropriate parameters
- e. Provide playback information from the task for training analysis

All the routes required by scripts in the PDP-11/35 are written in either FORTRAN or MACRO. The source code for the routines is located on one of the RP04 disk packs.

TAT/21A37 INTERFACE APPROACH

**AUTONETICS INTERFACE.** The Autonetics interface between the AN/UYK-7s and the PDP-11/35 translates AN/UYK-7 NTDS channels signals into PDP-11/35 unibus signals. A block diagram of this interface is shown in Figure C-6.

This interface will block transfer data to the full NTDS FAST channel rate of 167K words (32-bits) per second. Since the PDP-11/35 is a 16-bit computer, two PDP-11/35 cycles are needed for each AN/UYK-7 cycle to transfer a 32-bit word to or from the PDP-11/35. Thus, the PDP-11/35 must be able to run at 334K words (16-bits) per second, with is no problem, since the unibus can transfer data up to 1.1M words (16-bits) per second.

The Digital Equipment Corporation DR-11B is the standard DEC general purpose direct memory access (DMA) parallel data controller. Its specifications are given in the DEC PDP-11/35 Peripherals Handbook.

The section of the interface built by Autonetics:

- a. Translates the NTDS FAST OVDC to -3 VDC logic levels to  $T^2$  levels or vice versa
- b. Multiplexes the AN/UYK-7's 32 data lines into 16 data lines for the PDP-11/35
- c. Demultiplexes the PDP-11/35's 16 data lines into 32 data lines for the AN/UYK-7
- d. Provides appropriate timing and control for the NTDS control lines and DR-11B control lines so that data blocks, interrupts, and status words can be transferred in either direction

The PDP-11 controls the state of the Autonetics interface. This includes:

- a. DMA out from PDP-11/35
- b. DMA into PDP-11/35
- c. Waiting for interrupt from AN/UYK-7
- d. Sending interrupt to AN/UYK-7
- e. Receiving function (status) word from AN/UYK-7
- f. Sending interrupt (status) word to AN/UYK-7

The AN/UYK-7 acts like an intelligent slave on this channel, being only allowed to function in the mode the PDP-11/35 has set on the interface.

A sample scenario would be:

- a. PDP-11/35 sets interface to allow AN/UYK-7 to interrupt it
- b. AN/UYK-7 wants to send a 4K word data block
- c. AN/UYK-7 must send interrupt to PDP-11/35

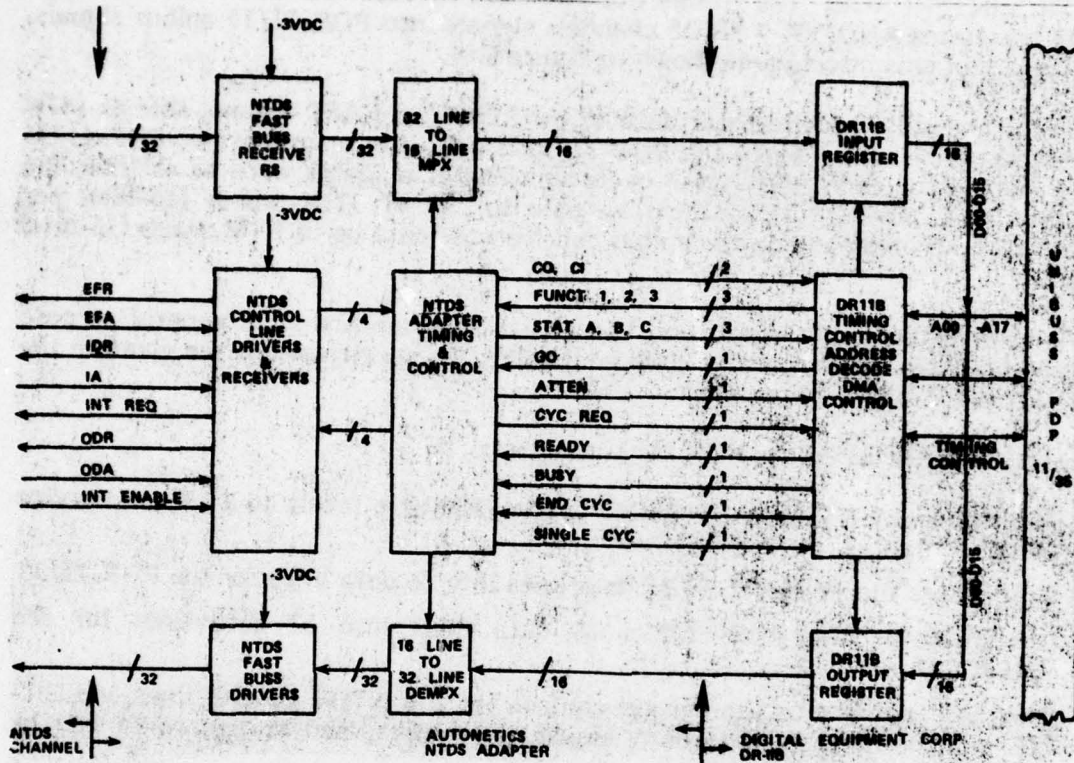

Figure C-6. Autonetics Interface

## NAVTRAEQUIPCEN 77-C-0107-1

- d. PDP-11/35 receives interrupt and allows AN/UYK-7 to send function words by raising external function request (EFR)
- e. AN/UYK-7 sends function words indicating block size, transfer direction, and data type
- f. PDP-11/35 receives function words, sets up interface for DMA into PDP-11/35 into a particular buffer, and signals AN/UYK-7 to send data by raising and lowering output data request (ODR) for each word
- g. When word count register in DR-11B goes to zero, PDP-11/35 completes data transfer, send interrupt and interrupt status word to AN/UYK-7 stating transfer complete, and waits for acknowledgement
- h. AN/UYK-7 acknowledges interrupt
- i. PDP-11/35 receives acknowledgement and sets interface in waiting for AN/UYK-7 interrupt mode
- j. AN/UYK-7 checks if the transfer on its side is completed properly. If it did not complete transfer properly, it sends interrupt to PDP-11/35
- k. If PDP-11/35 receives interrupt, the interface is set to receive external function words from AN/UYK-7
- l. AN/UYK-7 sends external function words indicating band transfer
- m. PDP-11/35 receives external function words and takes whatever action is required by the program (retransmission, abort, etc)

Data transfer requires relative standardized procedures to ensure proper conveyance of data. If errors occur, standardized recovery procedures are automatically initiated.

**NUSC INTERFACE.** Within the last year, the Naval Underwater Systems Center (NUSC), New London Laboratory, has designed and constructed an interface similar to the Autonetics interface. The NUSC interface allows computer with NTDS FAST channels to communicate with PDP-11/35s. Discussion with laboratory personnel indicate that the NUSC interface operates similarly to the Autonetics interface except that the NUSC interface was designated to operate with AN/UYK-20 computers and associated peripherals. This results in differences regarding the meaning of the DR-11B function codes and status bits. As indicated, the NUSC interface uses a DEC DR-11B on the PDP-11/35 side and specially designed logic on the NTDS side.

This interface was presently designed only transfers 16-bit words on the NTDS side, since it was designed for AN/UYK-20 (16-bit) equipments. NUSC personnel stated that to use it with AN/UYK-7 equipments (32-bit) either the interface would need minor design modifications or the data in the AN/UYK-7 would have to be formatted into or out of 16-bit upper-half word or lower-half word format. The design modifications required would consist of:

- a. Additional NTDS drivers and receivers
- b. A 16-to-32 bit demultiplexer

NAVTRAEQUIPCEN 77-C-0107-1

- c. A 32-to-16 bit multiplexer
- d. Changes in the control logic requesting two PDP-11/35 I/O cycles for every AN/UYK-7 cycle

The NUSC interface, as well as the Autonetics interface, can operate with the NTDS SLOW channel (logic levels of OVDC and -15 VDC). This type of operation would require, in addition to the normally used NTDS FAST channel, (1) appropriate supply voltage changes on the NTDS drivers and receivers, (2) several pulse width changes, and (3) the ANEW channel with appropriate changes in the line drivers and receivers. It should be noted that both interfaces have software drivers that have been fully integrated into DEC's RSX-11 operating system.

Furthermore, both interfaces provide the user with a means of transferring data between the popular DEC PDP-11/35 series of computers and military computer hardware (UYK-7, UYK-20, etc) utilizing NTDS FAST, NTDS SLOW, and ANEW channels. The interfaces are designed to permit the user to define transfer protocol, data block sizes, data types, and status word definitions for the particular application at hand.

**CANDIDATE APPROACHES.** A number of different approaches were evaluated to accomplish the TAT/simulator interface. In each case the major consideration is the amount of software to be modified and to be originally written. Discussions with NUSC, SUBSCOL and Singer-Link personnel indicate that generation and modification of software for AN/UYK-7s is more time consuming and difficult than for a commercial computer such as PDP-11s and NOVA3s. Thus the approaches considered either do not require any AN/UYK-7 changes or just require minor modifications. The major amount of software will be done in a PDP-11 computer. The different approaches are evaluated below:

First Approach -- 21A40/Tektronics 4051 Interface. This method was developed and used by Submarine School personnel at San Diego on the 21A40 Trainer located there. Figure C-7 is a detailed block diagram of their technique. The data required (fire control range, fire control course, true range, true course, and signal to noise) for this particular performance evaluation method is picked off by specially designed and modified hardware in the acoustic data processor, Unit 9, of the 21A40 Trainer. The data is then sent serially to a Tektronix 4051 Desk Top Calculator for analysis during run-time. There are two basic reasons why this technique will not work for the proposed performance evaluation on the 21A37/4 Trainer.

First, the 21A37 and 21A40 Trainers are distinctly different systems sharing no common hardware designs. Thus, the hardware approach used on the 21A40 cannot be used on the 21A37. Secondly, the performance evaluation system proposed for the 21A37 is more comprehensive than that done on the 21A40 Trainer. The proposed system requires not only the knowledge of the five parameters used on the 21A40 performance system, but also an additional 25 to 30 parameters to comprehensively monitor the performance on the training system.

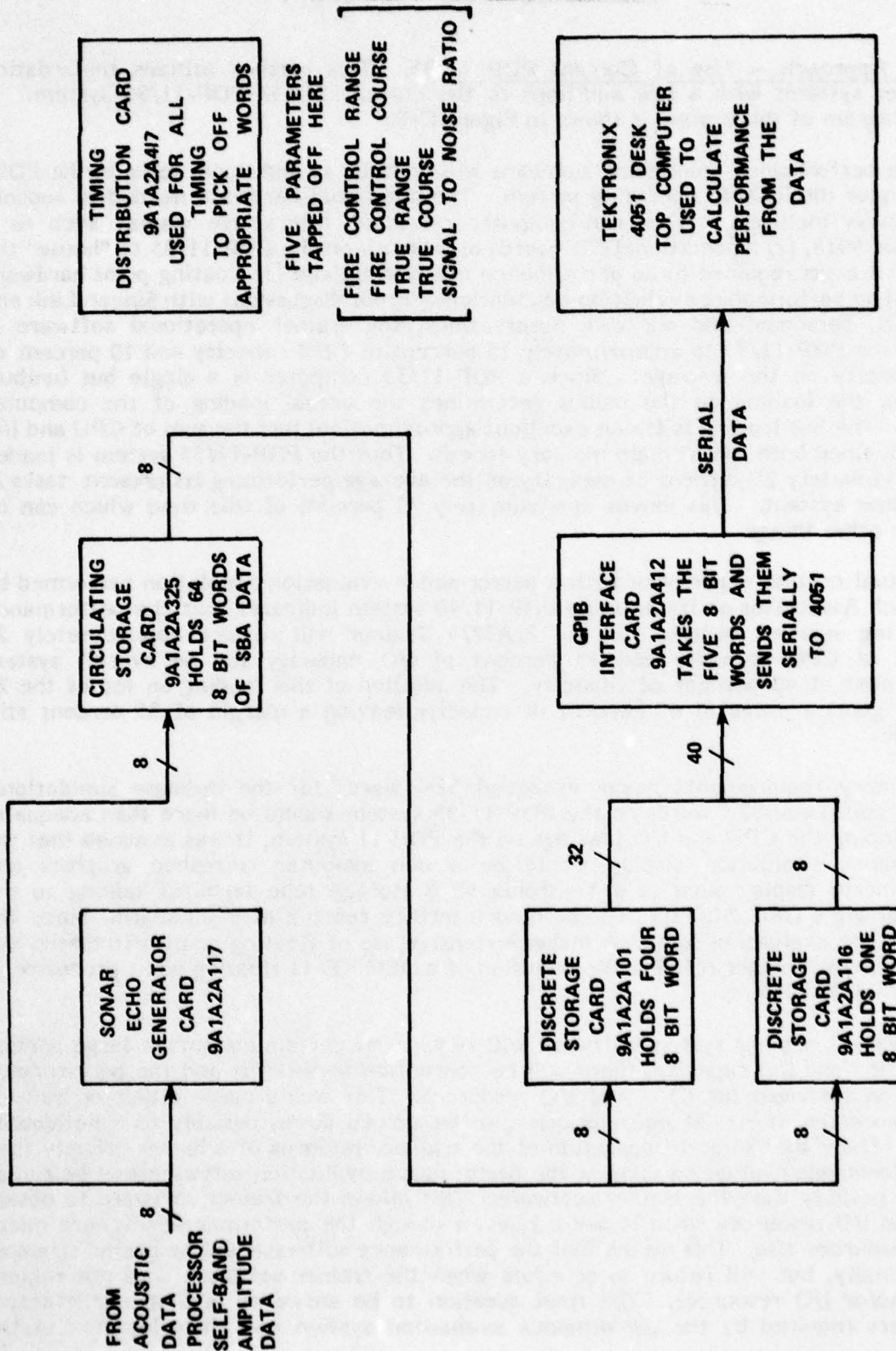

Figure C-7. 21A40 Performance Monitor

## NAVTRAEQUIPCEN 77-C-0107-1

Second Approach -- Use of Current PDP 11/35. This method utilizes the existing computer systems with a few additions to the current 21A37 PDP-11/35 system. A block diagram of this system is shown in Figure C-8.

The performance monitoring software will be built as additional tasks in the PDP-11/35 under the RSX-11 operating system. The additional hardware needed to support these tasks includes: (1) a non-computer refreshed interactive display such as a Tektronix 4014, (2) an additional 32K words of memory on the PDP-11/35 to "house" the additional tasks required to do performance monitoring, and (3) floating point hardware to speed up performance evaluation calculations. From discussions with Singer-Link and SUBSCOL personnel and our own observations, the trainer operational software is loading the PDP-11/35 to approximately 15 percent of CPU capacity and 10 percent of I/O capacity on the average. Since a PDP-11/35 computer is a single bus (unibus) machine, the loading on the unibus determines the actual loading of the computer system. The bus loading is (to an excellent approximation) just the sum of CPU and I/O loadings, since both run at main memory speeds. Thus the PDP-11/35 system is loaded to approximately 25 percent of capacity on the average performing its present tasks in the trainer system. This leaves approximately 75 percent of idle time which can be used for other things.

Actual routine experience with a performance evaluation simulation performed by Eclectech Associates on its in-house PDP-11/40 system indicates that the performance monitoring system required for the 21A37/4 Trainer will require approximately 25 percent of CPU capacity and 15 percent of I/O capacity for an overall system requirement of 40 percent of capacity. The addition of this loading on top of the 25 percent gives a usage of 65 percent of capacity leaving a margin of 35 percent still available.

Memory requirements never exceeded 32K words for the in-house simulations. Thus an additional 32K words on the PDP 11/35 system should be more than adequate. In developing the CPU and I/O loadings on the PDP-11 system, it was assumed that the performance evaluation display would be a non-computer refreshed graphics and alphanumeric display such as a Tektronix 4014 storage tube terminal talking to the computer via a DEC DL-11D asynchronous interface running at 9600 baud. Since the performance evaluation software makes extensive use of floating point arithmetic, the system loading number reflects the inclusion of a DEC KE-11 floating point processor in the PDP-11/35 system.

Since the trainer system software will require, at certain instants, a large portion of the CPU and I/O capacity, there will be contention between it and the performance evaluation software for CPU and I/O resources. This would cause either or both of these processes, if run at equal priority, to be slowed down, possibly to a noticeable extent. Since the "smooth" operation of the trainer system is of a higher priority than the performance evaluation system, the performance evaluation software will be run at a lower priority than the trainer software. This allows the trainer software to obtain CPU and I/O resources when it needs it even though the performance software needs those resources also. This means that the performance software will be behind schedule occasionally, but will return to schedule when the trainer software does not require CPU and/or I/O resources. The final question to be answered is that of the actual parameters required by the performance evaluation system and their location in the

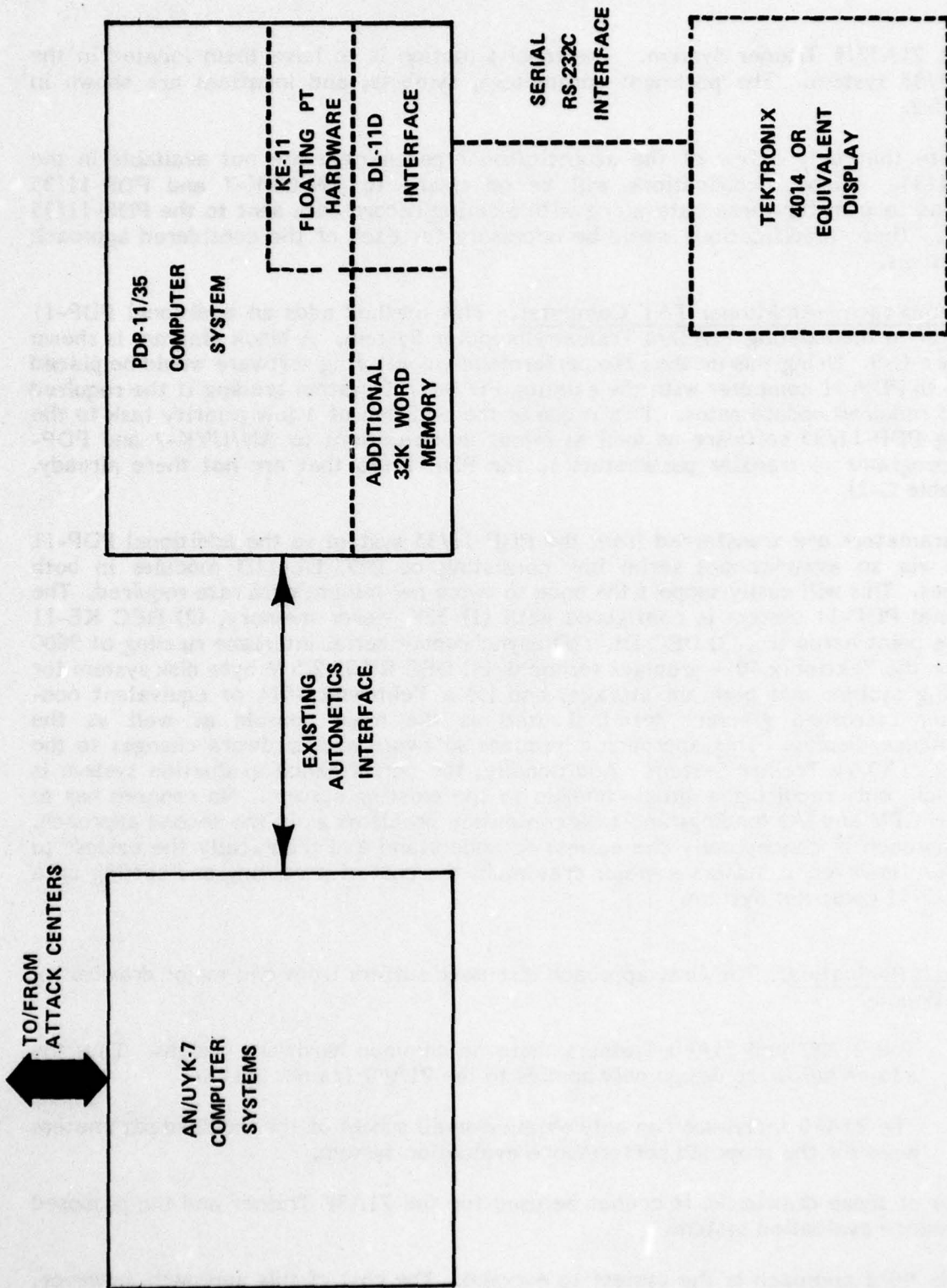

Figure C-8. Second Approach System

## NAVTRAEQUIPCEN 77-C-0107-1

present 21A37/4 Trainer System. The ideal situation is to have them located in the PDP-11/35 system. The pertinent parameters, symbols, and locations are shown in Table C-2.

Note that only a few of the acoustic/sonar parameters are not available in the PDP-11/35. Minor modifications will be necessary to AN/UYK-7 and PDP-11/35 programs to transfer these data along with existing record data sent to the PDP-11/35 system. These modifications would be necessary for each of the considered approach alternatives.

Third Approach -- Additional TAT Computer. This method adds an additional PDP-11 computer to the existing 21A37/4 Trainer Computer System. A block diagram is shown in Figure C-9. Using this method the performance monitoring software would be placed in its own PDP-11 computer with the existing PDP-11/35 system sending it the required data at required update rates. This requires the addition of a low priority task to the existing PDP-11/35 software as well as minor modifications to AN/UYK-7 and PDP-11/35 programs to transfer parameters to the PDP-11/35 that are not there already. (See Table C-2).

Parameters are transferred from the PDP-11/35 system to the additional PDP-11 system via an asynchronous serial link consisting of DEC-DL-11D modules in both machines. This will easily support the once to twice per minute data rate required. The additional PDP-11 system is configured with (1) 32K words memory, (2) DEC KE-11 floating point hardware, (3) DEC DL-11D asynchronous serial interface running at 9600 baud for the Tektronix 4014 graphics terminal, (4) DEC RK05 2.5 M byte disk system for operating system and program storage, and (5) a Tektronix 4014 or equivalent non-computer refreshed graphics terminal used as the main console as well as the performance display. This approach minimizes software and hardware changes to the existing 21A37/4 Trainer System. Additionally, the performance evaluation system is an add-on, only requiring a simple hookup to the existing system. No concern has to be given to CPU and I/O loadings and task contention problems as in the second approach. This approach is conceptually the easiest to understand and technically the easiest to execute. However, it suffers a major drawback, the cost of procuring and setting up a new PDP-11 computer system.

Approach Evaluation. The first approach discussed suffers from two major drawbacks, as mentioned:

- a. The 21A37 and 21A40 Trainers share no common hardware designs. Thus the add-on hardware design only applies to the 21A40 Trainer System.
- b. The 21A40 technique can only obtain a small subset of the required parameters need for the proposed performance evaluation system.

Because of these drawbacks it cannot be used for the 21A37 Trainer and the proposed performance evaluation system.

The third approach is the easiest to execute. The cost of this approach, however, would be somewhat higher than the second approach. The second approach is therefore

TABLE C-2. REQUIRED DATA SYMBOLS, LOCATIONS, TYPE

<u>Name</u>	<u>Standard Symbol</u>	<u>Singer-Link Symbol</u>	<u>Location</u> PDP-11 UYK-7	<u># Of Variables</u>	<u>Type</u>
Time	t	EXTIME	X	1	32 Bit Signed Integer
Own Ship X Posit	Xo	PS090SX	X	1	32 Bit Signed Integer
Own Ship Y Posit	yo	PS090SY	X	1	32 Bit Signed Integer
Own Ship Course	Co	PS06HDG	X	1	32 Bit Signed Integer
Own Ship Speed	DMHo	PS05SPED	X	1	32 Bit Signed Integer
Own Ship Depth	Hvo	PS07DPTH	X	1	32 Bit Signed Integer
Target X Posit	xt	PT09TPX	X	7	32 Bit Signed Integer
Target Y Posit	yt	PT09TPY	X	7	32 Bit Signed Integer
Target Course	Ct	PT06HDG	X	7	32 Bit Signed Integer
Target Speed	DMHt	PT05SPED	X	7	32 Bit Signed Integer
Target Depth	Hvt	PT07DPTH	X	7	32 Bit Signed Integer
Target True Bearing	By				
Target Range	Rh				
Target D/E Angle	Eua				
Propagation Loss	Nw				
Sonar Sig Path	Dir, Bot, Etc				
Target Rad Noise	Lst				
Own Ship Rad Noise	Lso				
Sig Excess at Own Ship	Let				
Sig Excess at Target	LEo				
Own Ship Baffle Effects	DB Loss				
Sonar Track In ATF	Yes/No				
Target Baffle Effects	DB Loss				
FCS Tracking Sonar	Yes/No				
Target Detected	Yes/No				
Signal to Noise Ratio	SNR	ISUSSNR	X	7	16 Bit Integer Unsigned
FCS TMA Designator Sol/n	Mate/KA				
TMA Bearing	TMA BY	TDAPBEAR	X	7	32 Bit Signed Real
TMA Course	TMA Ct				
TMA Speed	TMA St				
TMA Range	TMA Rh	TDAPRANG	X	4	32 Bit Signed Real
TMA Depth	TMA Hut				

TABLE C-2. REQUIRED DATA SYMBOLS, LOCATIONS, TYPE (CON'T)

<u>Name</u>	<u>Standard Symbol</u>	<u>Singer-Link Symbol</u>	<u>Location</u> <u>PDP-11</u> <u>UYK-7</u>	<u># Of Variables</u>	<u>Type</u>	
Own Ship Weapon Launch	Yes & Time	VENT, RPTIMWRK	X	X	4	
Own Ship Weapon Type	Type #					
Own Ship Weapon Acquire	Yes & Time	PRFRANGE	X	X	7	32 Bit Signed Real
Position Keeping Flat Range		PRSRANGE	X	X	7	32 Bit Signed Real
Position Keeping Slant Range		PRTBEAR	X	X	7	32 Bit Signed Real
Position Keeping True Bearing						

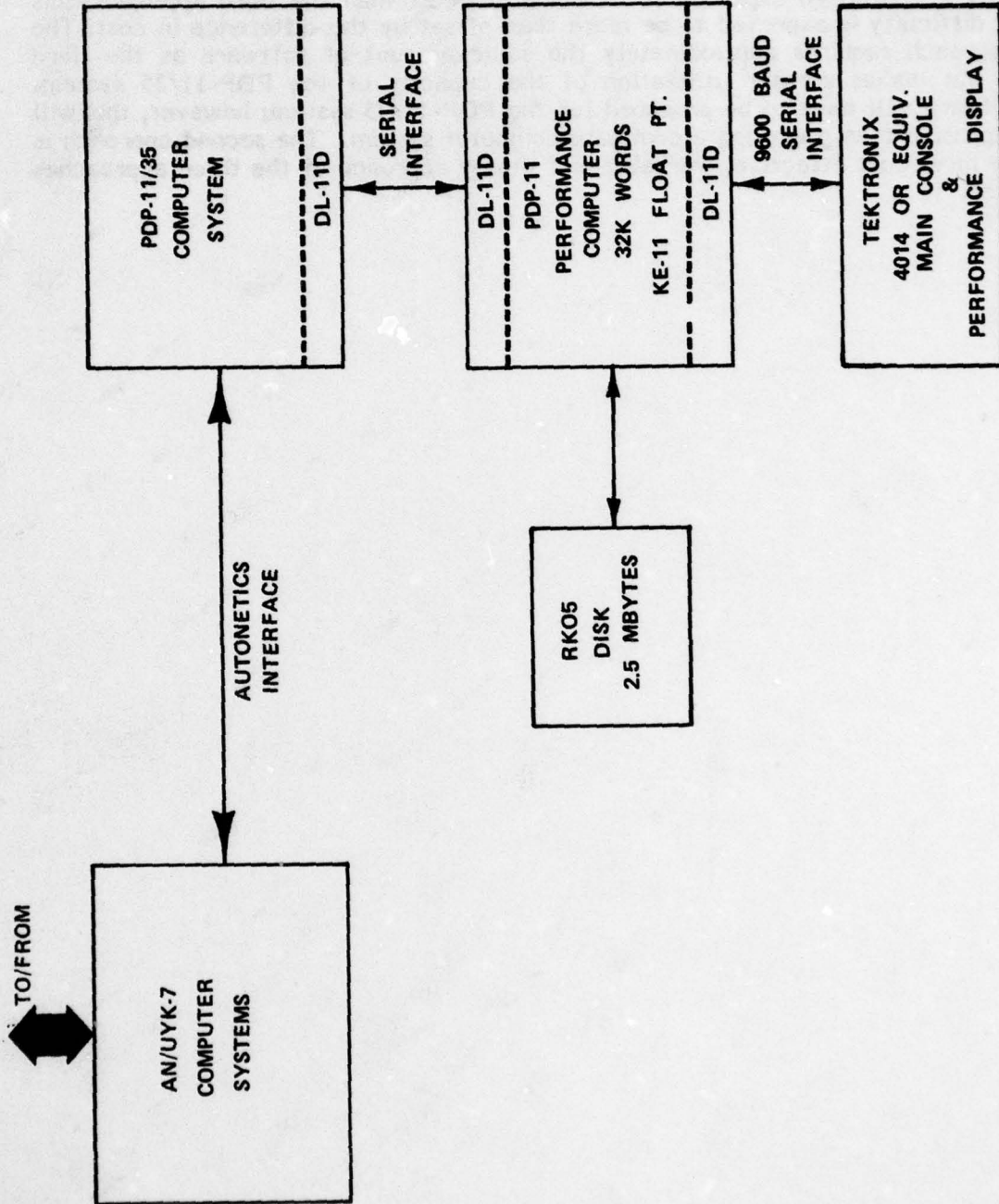

Figure C-9. Third Approach System (Additional Hardware Shown by Dotted Lines)

AD-A072 030

ECLECTECH ASSOCIATES INC NORTH STONINGTON CONN  
TRAINING ASSISTANCE TECHNOLOGY INVESTIGATION.(U)  
MAY 79 T J HAMMELL, H T MANNING, F M EWALT

F/6 5/9

N61339-77-C-0107

UNCLASSIFIED

NAVTRAEQUIPC-77-C-0107-1

NL

2 OF 2  
AD  
A072030



END  
DATE  
FILMED  
9-79  
DDC

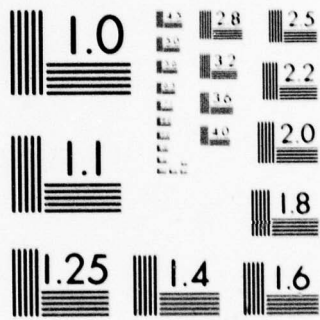

MICROCOPY RESOLUTION TEST CHART  
NATIONAL BUREAU OF STANDARDS-1963-A

recommended. Although expected to be more difficult than the third approach, this additional difficulty is expected to be more than offset by the difference in cost. The second approach requires approximately the same amount of software as the third approach, but makes greater utilization of the capacity of the PDP-11/35 system. Extra hardware will have to be procured for the PDP-11/35 system; however, this will be less expensive than procuring a complete computer system. The second approach is by far the most cost effective, workable and timely approach of the three approaches investigated.

APPENDIX D  
SUMMARY OF MODULE TRAINING CONTENTS

INITIAL TMA — MODULE 1

**TIME ON LEG CONSIDERATIONS EXERCISE.** Understand the effect that delta bias and time on leg have on probable bearing accuracy/DBy error. Performance to be 100 percent correct in definition of direction and relative order of magnitude of the anticipated effect.

Demonstrate an understanding of the effects of SNR, for a given 0.1 probable DBy error, on the minimum time required steadiied on a maneuver leg. Demonstrate this knowledge by maneuvering when the minimum number of display data units have gathered (equates to a specific elapsed problem time). Maneuver recommendation must be no less than optimum time on leg and no greater than 5 minutes on any maneuver leg.

Demonstrate an understanding of the effect that time on leg has on time to approach position station by verbalizing the effect that a longer than required time on leg (for 0.1 probable DBy error) will have on time to approach position station. Answers will be 100 percent correct in direction and relative order of magnitude of effect. Answers shall include the effects of excessive time on leg on average values of  $xDMh_o$ ,  $yDMh_o$ .

**$xDMh_t$  MATCHING EXERCISE.** State the tactical variables that can be identified based on detection leg tactical data. Include in explanation:

- a. Role of SNR and DBy in estimating bearing accuracy and range accuracy. 100 percent accuracy for situation representing combinations of LOW/HIGH (2 /min) DBy, and LOW/HIGH (0 dB) SNR.
- b. Meaning of bearing drift for a known  $xDMh_o$ , LOS, and estimated target speed. 100 percent accuracy for situation representing meeting, crossing, and overtaking encounter geometries.

Demonstrate an understanding of the available SNR and DRM information by recommending a maneuver which will match  $xDMh_t$ . Accuracy within  $\pm 0.25$  DBy minimum.

**RANGE UNCERTAINTY EXERCISE.** Demonstrate an understanding of the tactical implications of range uncertainty by:

- a. Initially maneuvering to avoid collision (away from the target attack) for a high DBy, high SNR contact.
- b. Initially maneuvering to avoid counterdetection ( $DMh_o$ /aspect changes) for a low SNR, high DBy contact.

- c. Initially maneuvering to avoid too great a loss in target true bearing for a high DBy, low SNR contact (minimize  $xDMh_o$  on opposite side of LOS).

Maneuvers will be 100 percent correct in direction and magnitude for the specific maneuver objective.

#### TMA MANEUVERS (SOLUTION ACCURACY) — MODULE 2

**SOLUTION ACCURACY EXERCISE.** Demonstrate an understanding of the relationship between  $|DBy_n - DBy_{n+1}|$  and solution accuracy by recommending a maneuver which will maximize solution accuracy for:

- a. Lead history leg (no speed constraints)
- b. Lag history leg
  1. Speed constrained (no overlead possible)
  2. No speed constraints

The maneuver recommendation must be accurate within  $\pm 5 C_o$  of the geometric vector alternative which produces the highest end point value of SA.

#### TMA MANEUVERS (CLOSING RATE) — MODULE 3

**CLOSING RATE EXERCISE.** Demonstrate an understanding of the concepts of approach offset and closing rate by recommending a maneuver which maximizes closing rate to the approach offset for underlead and lag encounter geometries. Maneuver recommendation must be within  $\pm 5$  degrees of the highest value CR alternative geometry.

Demonstrate an understanding of the effectiveness of own ship in utilizing  $yDMh_o$  to shorten time to station while maximizing CR to the approach offset. The trainee must use 100 percent of available own ship speed and must match  $xDMh_t$  within  $\pm 0.25$  degrees DBy right or left.

#### PROBABILITY OF COUNTERDETECTION — MODULE 4

**PROBABILITY OF COUNTERDETECTION EXERCISES.** Demonstrate an understanding of the tactical variables which determine the value of probability of counterdetection by recommending maneuvers which meet and approach objective while producing minimum maneuver leg end point PCD for own ship speed constrained to 4 knots. Verbalize the maneuver recommendations which would produce high values of PCD for a projected maneuver leg. Maneuver recommendations must be within  $\pm 10$  degrees of the PCD minimum maneuver.

OPTIMUM GEOMETRY — MODULE 5

OPTIMUM GEOMETRY EXERCISE. Demonstrate an understanding of the CR, SA, PCD approach tactical tradeoff by recommending maneuvers which account for all three tactical considerations. Be able to verbalize that maneuver rationale.

APPENDIX E  
TRAINING STRATEGY SUMMARY

A. Initial TMA - Module One

1. Training Technique (Methodology)

- a. Positive guidance (demonstration displays)
- b. Immediate feedback
  - Knowledge of results
  - Knowledge of alternatives

2. Displays

- a. Operational - geoplot (track history)
- b. Demonstration
  - TAT geoplot
  - TAT feedback displays
- c. Feedback
  - Alternative LOS
  - xDMh<sub>t</sub> matching
  - Three graph

3. Instructor Function/Performance Measures

The instructor provides the trainee/team with a demonstration scenario prior to beginning the training exercise scenarios. The demonstration scenario will provide information concerning CRT display information, exercise objectives, and performance measures prior to the actual tactics training presentation.

The tactics training presentation will use the same geoplot operational display, and TAT feedback displays as used in the demonstration scenario.

The instructor will identify the trainee's performance and provide feedback to the trainee/team relative to the following performance measures:

Exercise One - Time on Leg Considerations

- a. Time on leg
- b. Signal-to-noise ratio
- c. Own ship listening aspect

## NAVTRAEQUIPCEN 77-C-0107-1

- d. Bearing rate error probability
- e. Time to station (TS performance measure)

### Exercise Two - $xDMh_t$ Matching

- a. Time to constrain tactical variables, e.g., establish DRM, estimate  $xDMh_t$  based on bearing rate, range (SNR), and  $xDMh_o$  information
- b. Accuracy of  $xDMh_t$  matching trainee maneuver recommendation ( $C_o$ ,  $DMh_o$ , DBy)

### Exercise Three - Range Uncertainty

- a. Appropriateness in direction and magnitude of own ship course (speed ( $DMh_o$ ) is held constant) maneuver recommendation
- b. Appropriateness of maneuver with respect to deriving a minimum or a maximum range bracket for target
- c. SNR
- d. DBy
- e.  $|DBy_n - DBy_{n+1}|$
- f. Solution accuracy (SA performance measure)
- g. Range

#### 4. Trainee Input Characteristics

Training is provided at the FCC/AO level. This initial TMA training module provides a refresher of basic TMA knowledge and skills. Trainees in a SOAC or PXO curriculum may find little challenge in the training material. The intent is to provide an accurate knowledge base from which to proceed to the next training module, where those knowledge and skills will be applied.

#### B. TMA Maneuvers: Solution Accuracy - Module Two

##### 1. Training Technique (Methodology)

- a. Positive guidance (demonstration displays)
- b. Immediate feedback
  - Knowledge of results
  - Knowledge of alternatives

2. Displays

- a. Operational - geoplot (track history)
- b. Demonstration
  - TAT geoplot
  - TAT feedback
- c. Feedback
  - Alternative LOS
  - Three graph

3. Instructor Functions/Performance Measures

The instructor provides the trainee/team with a demonstration scenario prior to beginning the training exercise scenarios. The demonstration scenario will provide information concerning CRT display information, exercise objectives, and performance measures prior to the actual tactics training presentation.

The tactics training presentation will use the same geoplot operational display and TAT displays as used in the demonstration scenario.

The instructor will identify the trainee's performance and provides feedback to the trainee/team relative to the following performance measures:

Exercise Four - TMA Maneuvers, Solution Accuracy

- a. Solution accuracy
- b.  $\left| \text{DBy}_n - \text{DBy}_{n+1} \right|$
- c. Previous history leg DBy (end point)
- d. Projected DBy (end point)
- e. SNR
- f. AOB
- g.  $\text{DMh}_p$
- h.  $C_o$

4. Trainee Input Characteristics

Training is provided at the FCC/AO level. This initial TMA maneuver module provides an information base for making maneuvering decisions with respect to the value of those maneuvers to improve the accuracy of the TMA solution. Trainees in a SOAC or PXO curriculum will find this module more stimulating

than the first in that it provides a conceptual framework for some very applied problems; i.e., how much  $DMh_0$  is required for a high degree of solution accuracy.

C. TMA Maneuvers: Closing Rate - Module Three

1. Training Technique (Methodology)

- a. Positive guidance (demonstration displays)
- b. Immediate feedback
  - Knowledge of results
  - Knowledge of alternatives

2. Displays

- a. Operational - geoplot (track history)
- b. Demonstration
  - TAT geoplot
  - TAT feedback
- c. Feedback
  - Alternative LOS
  - Three graph

3. Instructor Functions/Performance Measures

The instructor provides the trainee team with a demonstration scenario prior to *beginning the training exercise scenarios*. The demonstration scenario will provide information concerning CRT display information, exercise objectives, and performance measures prior to the actual tactics training presentation.

The tactics training presentation will use the same geoplot operational display and TAT displays as used in the demonstration scenario.

The instructor will identify the trainee's performance and provide feedback to the trainee/team relative to the following performance measures:

Exercise Five - TMA Maneuvers, Closing Rate

- a. Closing rate (CR performance measure)
- b.  $xDMh_0$
- c.  $yDMh_0$
- d. Range (SNR)

- e. Track angle
- f. Own ship aspect

4. Trainee Input Characteristics

Training is provided at the FCC/AO level. This TMA maneuvers module provides an understanding of the concepts of the approach offset and provides the trainee with the knowledge of the most efficient approach when only considering the fastest possible approach to target. This knowledge is appended to the information provided in the previous module.

D. Probability of Counterdetection (PCD) - Module Four

1. Training Technique (Methodology)

- a. Positive guidance (demonstration displays)
- b. Immediate feedback
  - Knowledge of results
  - Knowledge of alternatives
- c. Delayed feedback

2. Displays

- a. Operational - geoplot (track history)
- b. Demonstration
  - TAT geoplot
  - TAT feedback
- c. Feedback
  - TAT geoplot (performance evaluation block)
  - Alternative LOS
  - Three graph

3. Instructor Functions/Performance Measures

The instructor provides the trainee team with a demonstration scenario prior to beginning the training exercise scenarios. The demonstration scenario will provide information concerning CRT display information, exercise objectives, and performance measures prior to the actual tactics training presentation.

The tactics training presentation will use the same geoplot operational display, and TAT feedback displays as used in the demonstration scenario.

## NAVTRAEQUIPCEN 77-C-0107-1

The instructor will identify the trainee's performance and provide feedback to the trainee/team relative to the following performance measures:

### Exercise Six - Probability of Counterdetection

- a. PCD
  - b. AOB
  - c. Range
  - d. Own ship aspect
  - e. Target baffle area
  - f. SNR
  - g.  $DMh_t$
  - h.  $DMh_p$
  - i. CR
4. Trainee Input Characteristics

Training is provided at the FCC/AO level. This exercise provides the trainee/team with an understanding of the impact of course and speed recommendation on PCD. An appreciation for the listening patterns of both own ship and target is stressed as is the relative effects of own ship and target  $DMh_o$  changes.

### E. Optimum Geometry - Module Five

1. Training Technique (Methodology)
  - a. Immediate feedback
    - Knowledge of results
    - Knowledge of alternatives
  - b. Delayed feedback
2. Displays
  - a. Operational - geoplot (track history)
  - b. Demonstration
    - TAT geoplot

NAVTRAEQUIPCEN 77-C-0107-1

- Feedback

c. Feedback

- TAT geoplot (performance evaluation block)
- Alternative LOS
- Three graph

3. Instructor Functions/Performance Measures

The tactics training presentation uses the same geoplot operational display and TAT displays used in the previous modules. This module integrates the various decision-making considerations trained in the earlier modules. This module is representative of the real world tactical decision-making tradeoffs.

The instructor will identify the trainee's performance and provide feedback to the trainee relative to the following performance measures:

Exercise Seven - Optimum Geometry

- PCD and the appropriate related tactical/performance measures, e.g., AOB, own ship aspect,  $DMh_o$ ,  $DMh_t$ , etc
- SA and the appropriate relative tactical/performance measures, e.g.,  $DBy_n - DBy_{n+1}$ ,  $xDMh_o$ ,  $xDMh_t$ , etc
- CR and the appropriate related tactical/performance measures, e.g., range, track angle, own ship aspect, etc.
- Quality of Approach (QA) as it summarizes SA, CR, and PCD

4. Trainee Input Characteristics

Training is provided at the FCC/AO level. This module integrates the maneuvering considerations of SA, CR, PCD, and QA. The trainee is assumed to have a knowledge of these measures prior to receiving the training in this module.

APPENDIX F  
TRAINING EXERCISES/SCENARIOS

The exercises in this appendix are aimed at replacing a segment of the existing SOAC/PXO training curriculum offered at SUBSCOL, New London. They are designed for use with the 21A37 (MK 113/10) Submarine Combat System Trainer. The scenarios which are included with the exercises provide a minimum number of initial problem parameters. These parameters address the fundamental tactical encounter variables, e.g., range, SNR,  $C_o$ ,  $DMh_o$ ,  $C_t$ ,  $DMh_t$ , etc. It is understood that the 21A37 simulation model is capable of defining many other initial parameters which enhance the realism of the simulation, e.g., sea state, layer depth, etc. Those parameters exceed the simulation requirements for training the selected approach phase objectives addressed in these modules. It is recommended that the problem controller/instructor assign those additional parameters in support of the initial parameters defined herein, e.g., sea state supportive of SNR, layer depth supportive of own ship and target operations depths, e.g., layer of no consequence.

The 20 training scenarios are also included in this appendix. Scenarios in the earlier TMA modules are mini-scenarios. That is, the scenario is only as long as required for the trainee to meet the training objective. The design consideration here was providing the maximum number of training exposures for a fixed training time. In this way the trainee (1) is provided operational target and own ship history information on which to base a maneuver, (2) decides on a maneuver, (3) observes the projected effect of that maneuver, (4) is provided feedback on performance measures specific to the exercise/training objectives, and (5) is provided instruction in attaining the objectives in upcoming/continuing scenarios. This is the entire training exercise process. The flow is depicted graphically in Figure F-1.

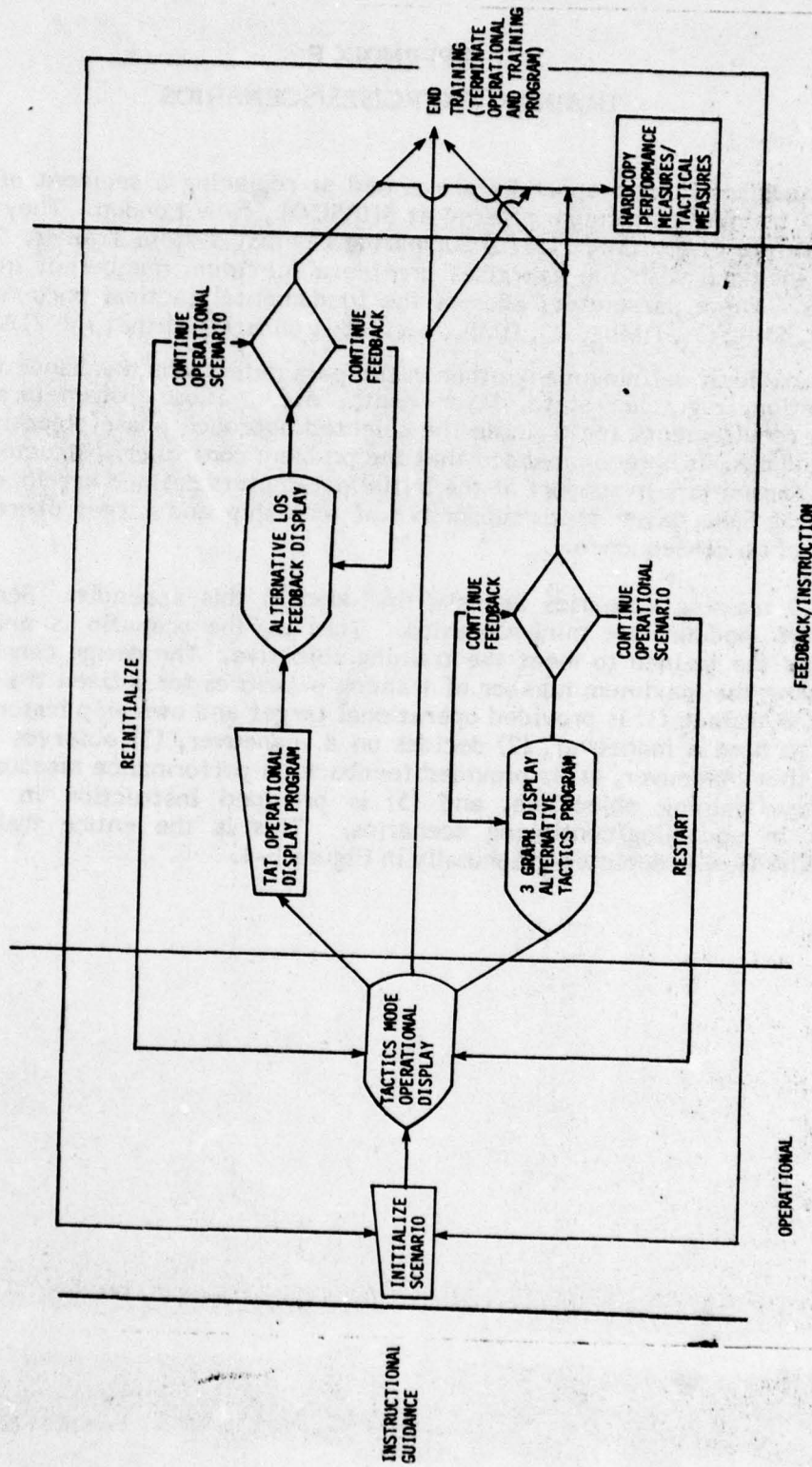

Figure F-1. Typical Exercise Flow

INITIAL TMA - EXERCISE #1 TIME ON LEG CONSIDERATIONS

NAVTRAEQUIPCEN 77-C-0107-1

TIME	EVENT	INSTRUCTOR FUNCTION	TRAINEE FUNCTION	DISPLAY
T-15	Prior to commencing demonstration scenario (explanation of variables influencing time on leg decision).	<ol style="list-style-type: none"> <li>Provide positive guidance to the trainee regarding the range of "acceptance times on leg" (min/max number FIDUs) for a specific probable error DBY and SNR. Provide appropriate graphic handouts illustrating same.</li> <li>Demonstrate/explain the effect delta bias has on accuracy of solution and O/S aspect with respect to target's relative bearing.</li> <li>Administer oral quiz of understanding of effects of delta bias and time on leg on solution accuracy. Provide feedback.</li> <li>Indicate to the trainee the behavior that will be required of him on the operational display. (i.e., Recommend a maneuver when he feels he has enough reliable data.)</li> <li>Specifying demonstration scenario number 1, problem time scale 1, etc.</li> <li>Review the variables determining time on leg. Indicate the location (on the operational display) of those variables (e.g., DBY, SNR, By and Problem time).</li> </ol>	<ol style="list-style-type: none"> <li>Understand the interactions of the variables that determine "acceptable times on leg". SNR DBY Error Probabilities</li> <li>Identify the effects delta bias and time on leg have on accuracy of solution.</li> <li>Understand his role in the scenario.</li> </ol>	<p>No display reference NWP 71-1 figure 5-8</p> <p>No display reference NWP 71-1 figure 5-2</p> <p>Tactics mode operational display</p>
T-10	Initialize demonstration scenario			

INITIAL TMA - EXERCISE #1 TIME ON LEG CONSIDERATIONS

TIME	EVENT	INSTRUCTOR FUNCTION	TRAINEE FUNCTION	DISPLAY
T+0	<p>Terminate demonstration scenario</p> <p>Initialize scenario</p>	<p>7. Indicate update rate of FIDU block display data (4 updates/min), O/S track display (1 update/min), and system solution display and target track (1 update/2 min).</p> <p>8. Keyboard terminate.</p> <p>9. Initialize scenario #2. Call up scenario via keyboard command specific to scenario file number (2) and scenario time (1x). Scenario only need be as long as time required for maximum number of FIDUs (for a .1 probable DBY error, with a 0 db SNR). Range of times steadied on leg (3 min - 5 min).</p>	<p>4. Understands location of information required for tactics decision, i.e., DBY, SNR, etc. Understands display update rates.</p> <p>5. Recommend a maneuver based on his perception of required FIDU minimum.</p>	<p>Operational display</p>
T+6	<p>Scenario finish diagnostic feedback</p>	<p>10. Pause operational display. Point out the frozen values of SNR, problem time and DBY with which probable error is associated.</p> <p>11. Indicate to trainee the range of acceptable performance for an SNR and its associated error probability. Indicate trainee performance relative to acceptable range. Indicate variables influencing the time on leg decision by referencing the handout graphics (NWP-71 table). Reemphasize objective of maneuvering when trainee has enough data.</p>	<p>6. Understand influencing variables behind time on leg decisions, i.e., DBY and SNR.</p>	<p>Frozen TAF operational display</p>

INITIAL TMA - EXERCISE #1 TIME ON LEG CONSIDERATIONS

NAVTRAEQUIPCEN 77-C-0107-1

TIME	EVENT	INSTRUCTOR FUNCTION	TRAINEE FUNCTION	DISPLAY
T+11	Initialize #3 scenario	12. Repeat above procedure. Keyboard initialize scenario number 3. Maneuver for .1 probable DBY error, with -7db SNR (5 minutes minimum).	7. Trainee recommends a maneuver.	Operational display
T+18	Scenario finish diagnostic feedback	13. Provide diagnostic feedback relative to trainee maneuver time versus minimum maneuver time. Terminate scenario.	8. Understand controlling variables.	Frozen TAT operational display
T+23	Prior to initializing scenario	14. Provide explanation of the effect of time on leg on time to station. Provide handouts graphically illustrating the effect that greater than optimum times on lag contribute to larger values of XDMH (average), which lengthens time to approach position station.	9. Understand the value of minimizing FIDUs (consistent with bearing accuracy) relative to time to station.	
T+30	Initialize scenario	15. Initialize scenario number 4. Initially, target -5 db SNR; .1 probable DBY error (3 minute minimum time on leg).	10. Trainee maneuvers to minimize time to station based on DBY and SNR.	Operational display
	Finish scenario	16. Record problem time at time of maneuver and present trainee's TS(N) performance on the frozen TAT operational display. Then pause problem.	11. Understand the effect his maneuver had on performance measure.	Frozen TAT operational display

INITIAL TMA - EXERCISE #1 TIME ON LEG CONSIDERATIONS

TIME	EVENT	INSTRUCTOR FUNCTION	TRAINEE FUNCTION	DISPLAY
T+35	Pause scenario	<p>17. Provide relationship between trainee time to maneuver and minimum maneuver time (for the maneuver-specific SNR.) Indicated impact on trainee value of TS(N).</p> <p>18. Indicate to trainee the objective is still to minimize time on leg and time to station values and that these upcoming maneuver recommendations are in the context of a continuous single scenario.</p>		
T+40	Reinitialize scenario	19. Exit pause routine. Restart operational display.		Operational display
T+45	Pause scenario	20. Repeat 13 and 14 providing diagnostic feedback including maneuver effect on time to approach position station.		Frozen TAT operational display
T+50	Terminate scenario	21. Terminate scenario. Conclude Exercise #1.		No display

EXERCISE #2 INITIAL TMA -  $xDMh_t$  MATCHING

TIME	EVENT	INSTRUCTOR FUNCTION	TRAINEE FUNCTION	DISPLAY
T-15	Prior to commencing demonstration/explanation	<ol style="list-style-type: none"> <li>Provide positive guidance to the trainee regarding DRM de-termination. Include:                             <ol style="list-style-type: none"> <li>Discussion of the parameters which are tactically most important.</li> <li>The location of those parameters on the operational display.</li> <li>SNR and DBY roles in range estimation and bearing accuracy.</li> <li>Interpretation of bearing drift/rate relative to LOS, for known <math>xDMh_o</math>, and target speed estimate.</li> <li><math>xDMh_t</math> matching procedures.</li> </ol> </li> <li>Generate 6 minute segment of scenario #5 to illustrate above points.</li> <li>Recommend a maneuver which matches <math>xDMh_t</math>. Enter maneuver. Bring up <math>xDMh_t</math> matching display. Indicate values of <math>xDMh_o</math>, <math>xDMh_t</math>, and DBY resulting from maneuver recommendation. Exit feedback display.</li> <li>Terminate scenario.</li> </ol>	<ol style="list-style-type: none"> <li>Understand what information can be gathered on first maneuver leg.</li> </ol>	<p>Tactics mode display</p> <p><math>xDMh_t</math> matching display</p>
	Initialize scenario			
	Scenario pause			
	Terminate scenario			

EXERCISE #2 INITIAL TMA -  $xDMh_t$  MATCHING

TIME	EVENT	INSTRUCTOR FUNCTION!	TRAINEE FUNCTION	DISPLAY
T+0	Initialize operational display	5. Initialize scenario. Specify scenario file #6. Generate 6 minutes of track history. Note trainee maneuver recommendation.	2. Observe operational display. Define, verbally, DRM values (i.e., By, DBY, and drift). Recommend a course and speed to match his estimation of $xDMh_t$ .	Operational display
T+6	Scenario pause (provide feedback)	6. Pause problem. Operational display frozen. Comment on frozen tactical parameters O/S, FIDU and System Solution Blocks. Select $xDMh_t$ matching display. Enter trainee course, speed recommendation.		$xDMh_t$ matching display
T+15	Terminate Scenario	7. Explain the projected values of $xDMh_t$ , $xDMh_t$ , and DBY relative to LOS. Discuss rationale for maneuver with trainee. Indicate direction and magnitude of required matching maneuver modification. 8. Terminate feedback display. 9. Indicates upcoming operational display is not a continuation of just shown scenario.	3. Understand what maneuver would match $xDMh_t$ , producing zero DBY. Trainee verbally states what effect overleading or underleading have on DBY for the specific encounter geometry.	No display

EXERCISE #2 INITIAL TMA - xDmht MATCHING

TIME	EVENT	INSTRUCTOR FUNCTION	TRAINEE FUNCTION	DISPLAY
T + 15	Initialize scenario	10. Initialize scenario #7 for a different encounter geometry. 11. Note trainee recommendation.	(i.e., representing LOS categories of meeting, crossing, and overtaking.) 4. Repeat #2	Operational display
	Scenario pause	12. Repeat #3 through #6 providing feedback for, Scenario #7.	5. Repeat #3	xDmht matching display
T + 30	Terminate scenario	13. Terminate scenario. Conclude exercise #2.		

EXERCISE #3 INITIAL TMA - RANGE UNCERTAINTY

TIME	EVENT	INSTRUCTOR FUNCTION	TRAINEE FUNCTION	DISPLAY
	Prior to commencing exercise #3 demonstration/explanation	1. Provide positive guidance to the trainee concerning range uncertainty concept. Indicate the tactical implications of range uncertainty (i.e., collision by overleading a close target (high SNR, high DBY)); counterdetection (low SNR, high DBY); or risking too great a loss in true bearing (target escape) by lagging a high DBY target to develop DBY.	1. Understands the maneuver option available to bracket target range. Understands the tactical parameters influencing ranging maneuvers, with respect to information about collision, target escape, and counterdetection. Understands the measures of his performance and the behavior modifications required to improve his performance.	
T-15	Initialize demonstration scenario	2. Initialize scenario file #8. Let the scenario generate for 6 minutes (for example), and pause the scenario.		Tactics mode operational display
		3. Describe maneuvers, referencing the frozen operational display LOS, illustrating potential collision and range bracketing maneuvers (based on SNR, DBY situations described in instructor function #1 above), e.g., maneuvering across the targets bow for a high SNR, high DBY target may result in collision.		Frozen operational display
		4. Indicate the information that is available on the operational display to aid to range determination (i.e., SNR, DBY, By, problem time system solution range).		

EXERCISE #3 INITIAL TMA - RANGE UNCERTAINTY

TIME	EVENT	INSTRUCTOR FUNCTION	TRAINEE FUNCTION	DISPLAY
T-10	Diagnostic Feedback	<p>5. Review the maneuvers that will provide crossed bearings for minimum or maximum range (lag or overlead) determination. Indicate that the accuracy of range bracketing is related to how much speed O/S puts across the LOS.</p> <p>6. Enter maneuver, in course (speed held constant) which bracket range while recognizing range uncertainty tactical considerations (e.g., collision, escape) Relate these maneuvers to column values of solution accuracy (range localization accuracy is a subset), <math>DBY_n - DBY_n + 1</math>, etc. Rows 1, 2, 3, 4, and 8 to be displayed (representing projected end point values of S.A. <math>\Delta DBY</math>; <math>DBY</math>, SNR, Range).</p>	<p>7. Indicate the role range uncertainty plays in determining lag and overlead maneuvers (SNR &amp; <math>DBY</math> cues for close aboard, counterdetection, and loss of true bearing situations reviewed). Indicate to the trainee that he is to recommend the optimum initial maneuver based on available information (SNR, <math>DBY</math> and tactical implications).</p>	Alternative LOS display

EXERCISE #3 INITIAL TMA - RANGE UNCERTAINTY

TIME	EVENT	INSTRUCTOR FUNCTION	TRAINEE FUNCTION	DISPLAY
T-0	<p>Terminate scenario</p> <p>Initialize scenario</p>	<p>8. Terminate feedback display. Terminate operational display.</p> <p>9. Initialize scenario #9. Let scenario generate from 6-10 minutes of track history. Indicate to the trainee he is to maneuver to resolve range uncertainty either minimum or maximum (specific to a scenario) while minimizing risk of collision or escape. (Higher xDMT provides greater solution accuracy but greater loss in true bearing from a lag maneuver.</p>	<p>1. By recommending a course and maintaining speed (initial maneuver), the Trainee will:</p> <p>Demonstrate an understanding of the tactical implications of range uncertainty.</p> <p>Demonstrate an understanding of the role of SNR and DBY in range bracketing. Understand the role of crossed bearings in range bracketing.</p>	<p>No display</p> <p>Operational display</p>
T + 6-10	Scenario pause	<p>10. Notes trainee maneuver recommended.</p> <p>11. Repeat instructor functions #4 and #5 entering trainee maneuver and alternative maneuvers (up to total maneuvers).</p>	<p>Trainee understands what initial maneuvers are required to meet objectives and what direction and magnitude of behavior modification is required.</p>	<p>Alt LOS geometry display</p> <p>Operational display</p>
T+15	<p>Diagnostic Feedback</p> <p>Terminate scenario</p> <p>Hard copy</p>	<p>12. Repeat instructor functions #6 and 7 providing performance feedback relative to maneuver recommendation.</p> <p>13. Initiate data save (as appropriate - TAT tactical and performance measures.</p> <p>14. Initialize scenario #10. Let track history generate. Record trainees maneuver recommendation.</p>	<p>3. Repeat #1</p>	
T+17	Initialize scenario			

EXERCISE #3 INITIAL TMA - RANGE UNCERTAINTY

TIME	EVENT	INSTRUCTOR FUNCTION	TRAINEE FUNCTION	DISPLAY
T + 23 to T + 27	Scenario Pause	15. Repeat instructor functions #4 through 7 entering Trainee maneuver and alternative maneuvers. Provide performance feedback.	4. Repeat #2	Alt. LOS geometry display
T+32	Hard copy	16. Initiate data save (as appropriate) - TAT tactical and performance measures.		No display
T+32	Terminate scenario	17. Terminate scenario #10. Conclude exercise #3.		

EXERCISE #4 TMA MANEUVERS - SOLUTION ACCURACY

TIME	EVENT	INSTRUCTOR FUNCTION	TRAINEE FUNCTION	DISPLAY
T-15	Prior to initializing scenario exercise #4	<ol style="list-style-type: none"> <li>Specify scenario #11 and time scale. After allowing a minimum number (approximately 6 minutes) of FIDUs to collect on the history leg pause the scenario and indicate to the Trainee the latest displayed values for System Sol., O/S, and most recent FIDU data. Indicate a maneuvering recommendation will be required after each history leg presentation in the upcoming training scenarios.</li> <li>Select alternative LOS feedback display.</li> <li>Enter the Trainee's maneuver recommendation (to be displayed as a flashing, higher intensity vector). Select the rows of data to be displayed (deleted) on the alternatives display (rows 1, 2, and 3 to be displayed).</li> <li>Select and insert the geometric alternatives of interest (maneuver alternatives representing a preferred maneuver and two alternatives (A&amp;B)) and explain the values of solution accuracy relative to</li> </ol>	<ol style="list-style-type: none"> <li>Understand scenario and exercise objectives. Understand display operations and information.</li> </ol>	<p>Tactics mode operational display</p> <p>Alt. LOS display</p>

EXERCISE #4 TMA MANEUVERS - SOLUTION ACCURACY

TIME	EVENT	INSTRUCTOR FUNCTION	TRAINEE FUNCTION	DISPLAY
		<p>most recent history leg DBY, and projected maneuver vector end point DBY.</p> <p>5. Select up to 4 alternative columns. Columns selected should represent, as a minimum:</p> <ul style="list-style-type: none"> <li>a. Trainee's maneuver recommendation</li> <li>b. Highest S.A. alternative. High xDMh opposite side of previous maneuver leg LOS. O/S aspect slightly less than (in degrees) target AOB up to 90° O/S aspect.</li> <li>c. Lowest S.A. alternative. Continue on same course and speed as previous maneuver leg. (Worst case is a continuing zero bearing rate course.)</li> </ul> <p>6. Explain the relationship between <math> DBY_n - DBY_{n+1} </math> and solution accuracy, generally. The larger the observation triangle base, the greater the solution accuracy. Indicate range accuracy (range uncertainty) is a subset of solution accuracy.</p>		

EXERCISE #4 TMA MANEUVERS - SOLUTION ACCURACY

TIME	EVENT	INSTRUCTOR FUNCTION	TRAINEE FUNCTION	DISPLAY
		<p>7. Indicate to the Trainee, the maneuvering objective for the upcoming scenario, i.e., maximize <math> DBY_0 - DBY_{n+1} </math> for the following scenario categories:</p> <ol style="list-style-type: none"> <li>a. lead history leg</li> <li>b. lag history leg                             <ol style="list-style-type: none"> <li>1. speed constrained (no overlead possible)</li> <li>2. no speed constraints</li> </ol> </li> </ol> <p>8. Explain that the maneuvering objective is not "real world" in that the conflicting tactical considerations of closing rate, probability of counter-detection, etc., are not addressed in these training scenarios. However, they will be included in approach objectives in exercises more advanced in this training program.</p> <p>9. Terminate demonstration operational/feedback displays.</p>		<p>No display</p>
T + 0	Initialize Scenario		<p>2. Trainee recommends a maneuver.</p>	Operational display

EXERCISE #4 TMA MANEUVERS - SOLUTION ACCURACY

TIME	EVENT	INSTRUCTOR FUNCTION	TRAINEE FUNCTION	DISPLAY
Approximately T+6 to T + 10	Scenario Pause	<p>11. Record Trainee maneuver recommendation.</p> <p>12. Terminate the operational display. Select the alternative LOS display (projection time for alternatives is 10 minutes.).</p> <p>13. Enter Trainee maneuver. Select rows (1, 2, 3) and columns to be displayed. Alternative selections (columns) should represent maximum and minimum S.A. and Trainee maneuver vectors. Additionally, vectors (if not one of the above) from each side of the line of sight should be included.</p> <p>14. Request the 3-graph feedback display. Indicate relationship between maneuvers (and associated tactical parameters) and solution accuracy. For example, the following interrelationships may be explored (as they contribute to solution accuracy) and can be displayed graphically).</p>	<p>3. Trainee understands what maneuvers will produce maximum solution accuracy. Understands end point future leg DBY (and associated LOS) and its influence on solution accuracy.</p>	<p>Alt. LOS display</p> <p>3-graph display</p>

T 15

EXERCISE #4 TMA MANEUVERS - SOLUTION ACCURACY

TIME	EVENT	INSTRUCTOR FUNCTION	TRAINEE FUNCTION	DISPLAY
		<p>Parameter                      a. xDMh O                      b. O/S aspect                      c. target course-Ct                      d. system solution target course-Ctk                      (The latter two ID's should be superimposed on the same graph).                      e. target range - Rh                      f. system solution target range - Rhk                      Parameters e and f are also to be superimposed on the same graph. NOTE: Generally, the parameter will be the y-axis and problem time will be the x-axis.</p>		
T + 20	Reinitialize	15. End feedback display and re-initialize operational display. Allow operational display to generate to next Trainee maneuver recommendation point. Record maneuver recommendation.	4. Trainee recommends a maneuver.	Operational display
Approximately T + 30	Scenario pause	16. Repeat #12, 13 & 14 for this scenario maneuver leg.	5. Repeat #3.	Alt. LOS display graphing display
T + 40	Reinitialize	17. Repeat #15.	6. Repeat #4.	Operational display

EXERCISE #4 TMA MANEUVERS - SOLUTION ACCURACY

TIME	EVENT	INSTRUCTOR FUNCTION	TRAINEE FUNCTION	DISPLAY
Approximately T + 50	Scenario pause	18. Repeat #12, 13 & 14.	7. Repeat #3.	Alt. LOS display
T + 60	Reinitialize scenario	19. Repeat #15.	8. Repeat #4.	Graphing display
T + 65	Terminate scenario	20. Repeat #12, 13 & 14 when trainee states he has accomplished the scenario objective or when objective is no longer obtainable.		Operational display
		21. Request hard copy of trainee performance measures if desired.		Alt. LOS display
T + 70		22. Conclude exercise.		

EXERCISE #5 TMA MANEUVERS - CLOSING RATE

TIME	EVENT	INSTRUCTOR FUNCTION	TRAINEE FUNCTION	DISPLAY
T - 20	Prior to initializing scenario	<ol style="list-style-type: none"> <li>1. Provide positive guidance to the trainee regarding operation of the closing rate performance measure. Indicate the tactical and performance measures of importance. Specify scenario #13 and time scale. Allow a minimum number of FIDUs to collect.</li> <li>2. Pause the scenario. Select the alternative LOS feedback display.</li> <li>3. Recommend a maneuver which most closely matches <math>xDMH_t</math>. The value for closing rate in the alternative column will indicate approximately 100% for any matched <math>xDMH_t</math> course less than or equals to a DRed <math>90^\circ</math> track angle relative to the approach objective point, (i.e., greater than <math>90^\circ</math> is no longer closing).</li> <li>4. Indicate it is unrealistic to DR for a collision. Indicate that track angles of less than <math>90^\circ</math> (<math>xDMH_t</math> matched) require higher O/S speeds and result in higher speeds in the line of sight. (Also, higher closing rate in LOS and less time to station) but will produce no</li> </ol>	<ol style="list-style-type: none"> <li>1. Understands the concepts of operational Approach Offset, Closing Rate (CR) (<math>xDMH_t</math>), and Closing Rate (CR) (<math>yDMH_t</math>). Trainee understands he is to recommend a maximum Closing Rate maneuver when he has enough data points.</li> </ol>	<p>Tactics mode operational display</p> <p>Alternative LOS display</p>

EXERCISE #5 TMA MANEUVERS - CLOSING RATE

TIME	EVENT	INSTRUCTOR FUNCTION	TRAINEE FUNCTION	DISPLAY
		<p>higher value of closing rate (CR) (as defined above) than any other matched <math>xDMh_t</math> course.</p> <p>5. Demonstrate the reduction in the value of closing rate for the same course as the previous <math>xDMh_t</math> matching recommendation.</p> <p>Key in new selections representing:</p> <ul style="list-style-type: none"> <li>a. Less speed than original recommendation (undershoot)</li> <li>b. More speed than original (overshoot)</li> </ul> <p>Indicate the values of closing rate associated with each selection and explain why they are less than optimum.</p> <p>6. Indicate the objective in the upcoming scenario is to maximize closing rate without changing O/S speed.</p> <p>7. Initialize scenario. Specify scenario file #14 and time scale. Allow problem to generate until trainee recommends a maneuver. Record trainee maneuver. Initial leg is underlead geometry.</p>	<p>2. Trainee recommends a maneuver and provides verbal rationale for maneuver, referencing anticipated closing rate for his maneuver recommendation and anticipated <math>yDMh_o</math> for that maneuver.</p>	<p>Operational display</p>
T - 15	Initialize scenario			

EXERCISE #5 TMA MANEUVERS - CLOSING RATE

TIME	EVENT	INSTRUCTOR FUNCTION	TRAINEE FUNCTION	DISPLAY
T - 10	Scenario pause	<p>8. Pause the operational display. Select the alternative LOS feedback display.</p> <p>9. Enter the trainee's maneuver recommendation. The trainee recommendation is displayed as a flashing vector. Specify rows to be deleted (only CR and <math>YDMh_0</math> to be shown).</p> <p>10. Indicate the value of closing rate and the value of <math>YDMh_0</math> for the trainee's maneuver and for a preferred and up to two other alternative maneuvers. One of the maneuvers should be either overshoot or undershoot, the direction of error opposite to the trainee's error direction.</p> <p>11. Request 3-graph display. Demonstrate trigonometric relationship between tactical parameters of O/S aspect, <math>DMh_0</math> and C.R. for the preferred maneuver the trainee's and two alternative maneuvers.</p> <p>12. Terminate scenario. Conclude demonstration scenario.</p>		<p>Alternative LOS display</p> <p>3-graph display</p> <p>No display</p>
T - 2	Terminate scenario			No display

EXERCISE #5 TMA MANEUVERS - CLOSING RATE

TIME	EVENT	INSTRUCTOR FUNCTION	TRAINEE FUNCTION	DISPLAY
T - 1	Prior to initializing	14. Explain that the exercise objective is to recommend a maneuver to minimize time to station (TSM, i.e., max. closing rate in the line of sight xDMh, matched, ICP). Maximum available O/S speed is 24 knots.		Operational display
T + 0	Initialize scenario	15. Repeat #7 for initial LOS lag geometry. Scenario file #15.		Alternative LOS display
T + 10	Scenario pause	16. Repeat #8, 9, 10 and 11, providing the appropriate feedback.		Graphing display
T + 20	Terminate scenario	17. Record (hard copy) tactical and performance data.		Operational display
T + 20	Initialize scenario	18. Repeat #7 for initial LOS lag geometry. (opposite of lag geometry, step #15). Scenario file #16.		Alternative LOS display
T + 30	Scenario pause	19. Repeat #8, 9, 10 and 11, providing appropriate feedback.		Graphing display
T + 40	Terminate	20. Repeat #12. Hard copy data to be saved for trainee/team/course history file.		No display

EXERCISE #6 PROBABILITY OF COUNTERDETECTION

TIME	EVENT	INSTRUCTOR FUNCTION:	TRAINEE FUNCTION	DISPLAY
T-20	Prior to initializing scenario	<p>1. Indicate to the trainee that he will be required to make more than one maneuver in the upcoming scenarios in order to meet the exercise objective of closing the target with a minimum of PCD. Initially, at each maneuver point that the trainee recommends the trainee will be provided feedback relative to the PCD value of that maneuver, i.e., did the maneuver increase or decrease PCD. Maneuvering for better TMA may be considered by the trainee in these maneuver recommendations, but this consideration is secondary to the primary objective of maneuvering to minimize PCD while closing the target to a specified approach objective point. Indicate to the trainee that after a "few" maneuvers (the exact number defined by observation of trainee maneuver recommendations which decrease PCD) the trainee will be appraised of his performance only when he has obtained the approach objective, i.e., delayed feedback.</p> <p>2. Specify scenario #17 and time scale. After allowing a minimum number of FIDUs to collect,</p>	<p>1. Trainee understands scenario and exercise objectives. Understands display operations and information. Understands that a maneuvering recommendation is required.</p>	Tactics mode operational display

EXERCISE #6 PROBABILITY OF COUNTERDETECTION

TIME	EVENT	INSTRUCTOR FUNCTION:	TRAINEE FUNCTION	DISPLAY
T - .10	Scenario pause	<p>pause the scenario and indicate to the trainee the latest displayed values for System Sol., O/S, and most recent FIDU data.</p> <p>3. Select alternative LOS display (10 minute projection).</p> <p>4. Enter the trainee's maneuver recommendation (to be displayed as a flashing, higher intensity vector). Select the rows of data to be displayed (deleted) on the alternatives display (rows representing projected end-point values for SNR, range, PCD, AOB, C R and YDMh<sub>o</sub>).</p> <p>5. Select the geometric alternatives of interest and explain the values of PCD relative to projected maneuver vector end-point.</p> <p>6. Select 4 alternative columns. Columns selected should represent, as a minimum:</p> <ul style="list-style-type: none"> <li>a. trainee's maneuver recommendation</li> <li>b. preferred PCD alternative</li> <li>c. two additional PCD alternatives</li> </ul>	<p>2. Understands the behavior modification that is required to improve his performance.</p>	Alternative LOS display

EXERCISE #6 PROBABILITY OF COUNTERDETECTION

TIME	EVENT	INSTRUCTOR FUNCTION	TRAINEE FUNCTION	DISPLAY
T - 1	Terminate scenario	<p>7. Explain the relationship between alternative column projected values of PCD, SNR, AOB, range, O/S Aspect, DMh, and DMh<sub>0</sub> (assuming no scenario target speed change).</p> <p>8. Indicate target baffle area and O/S radiated noise pattern as it predicts counterdetection.</p> <p>9. Enter a low PCD maneuver informing the trainee of the maneuver and its low PCD quality. Allow scenario to generate for 5 minutes. Indicate in the performance evaluation block on the tactics mode operational display the instantaneous and average PCD values. Terminate scenario. Conclude demonstration.</p>		No display
T - 0	Initialize scenario	<p>10. Indicate to the trainee the maneuvering objective for the upcoming scenario, (i.e., recommend maneuvers that close the target with minimum maneuver leg end-point PCD. (additionally, the trainee should be able to verbalize maneuvers which would maximize the value of PCD e.g., low DMh, excessive DMh, broad aspect, close range, etc.).</p>		

EXERCISE #6 PROBABILITY OF COUNTERDETECTION

TIME	EVENT	INSTRUCTOR FUNCTION:	TRAINEE FUNCTION	DISPLAY
T + 10	Scenario pause	<p>11. Specify scenario #18. Indicate the PCD maneuvering objective to the trainee, i.e., minimum PCD. Indicate potential maneuvering target.</p> <p>12. Pause scenario. Repeat steps 3 through 7. Provide performance feedback and outline tactical interactions.</p>		Operational display
T + 20	Continue scenario	<p>13. Allow a minimum number of FIDU to collect on this maneuver leg. Record trainee's maneuver.</p>	<p>3. Understand the effect this maneuver and other alternative maneuvers have on PCD.</p>	Alternative LOS display
T + 30	Scenario pause	<p>14. Repeat steps 3 through 7.</p>	<p>4. Understand the immediate effect of his maneuver on PCD.</p>	Operational display
T + 40	Continue scenario	<p>15. Repeat step 13 for this maneuver leg. Prior to entering the trainee's maneuver recommendation, display the instantaneous and average PCD values in the performance evaluation block (available upon request). Indicate those values to the trainee/team. Enter the trainee's maneuver. Indicate to the trainee/team the instantaneous value of PCD for the new course and speed. Indicate whether the maneuver</p>		TAT Operational display

EXERCISE #6 PROBABILITY OF COUNTERDETECTION

NAVTRAEQUIPCEN-77-C-0107-1

TIME	EVENT	INSTRUCTOR FUNCTION:	TRAINEE FUNCTION	DISPLAY
T + 75	Scenario pause	<p>resulted in an increase or a decrease in PCD. Delete the performance block information.</p> <p>16. Repeat step 15 for each maneuver leg as required until the approach objective is met.</p> <p>17. Reference the frozen operational display geoplot. Display these performance measures/tactical parameters on the 3-graph display:</p> <ul style="list-style-type: none"> <li>a. C<sub>o</sub></li> <li>b. DMh<sub>o</sub></li> <li>c. AOB</li> <li>d. O/S aspect</li> <li>e. PCD</li> </ul> <p>Indicate the effect of O/S and target (if any) maneuvers on PCD over the time length of the scenario. Particularly important is the change in PCD as the result of a tactical parameter change, e.g., O/S aspect, just after a maneuver recommendation.</p>	<p>5. Understand the interactive effects the tactical parameters have on PCD over problem time, e.g., the effects of tactical dynamics such as AOB, O/S aspect, etc. have on PCD over the entire problem time.</p>	<p>Operational display</p> <p>TAT operational display</p> <p>Operational display</p> <p>Graphing display</p>
T + 90	Terminate scenario	<p>18. Terminate scenario hard copy performance tactical data as required. Conclude exercise.</p>		No display

EXERCISE #7 OPTIMUM GEOMETRY

TIME	EVENT	INSTRUCTOR FUNCTION	TRAINEE FUNCTION	DISPLAY
T - 5	Prior to initializing scenario	<p>1. Indicate the upcoming scenario will reflect the tactically real tradeoffs of closing rate versus probability of counter-detection versus solution accuracy.</p> <p>2. Brief trainees on scenario approach objective. Specify track angle, range, PCD, objectives quantitatively. Require a maneuver with <math>DBY_n</math> to produce enough <math>DBY_{n+1}</math> to provide "good" solution accuracy (relatively high S.A.) while closing the target as "quickly" as possible relating high CR) and maintaining a minimum value of PCD. Indicate the availability of the quality of approach (QA) measure which summarizes the SA, CR, and PCD effectiveness.</p>	<p>1. Understand exercise objective, performance measures, and information available.</p>	<p>TAT operational display</p>
T - 0	Initialize scenario	<p>3. Specify scenario #19 and time scale. Indicate initial values displayed in Sys. Sol., O/S, and most recent FIDU blocks. As a minimum review, the following data is available on the TAT operational display:</p> <ul style="list-style-type: none"> <li>a. <math>DMh_0</math></li> <li>b. <math>C_0</math></li> <li>c. <math>HV_0</math></li> </ul>		

EXERCISE #7 OPTIMUM GEOMETRY

TIME	EVENT	INSTRUCTOR FUNCTION	TRAINEE FUNCTION	DISPLAY
		<p>d. DMh<sub>t</sub>                      e. target classification                      f. initial PCD                      g. approach objective information</p> <p>4. Indicate to trainee he is to stop the problem when feels he has accomplished the approach objective.</p> <p>5. During the scenario after a trainee has recommended a maneuver but before O/S has maneuvered the S.A., C.R., Q.A. and PCD measure values should be shown in the performance evaluation data block on the TAT operational display. This information should be on the display face just prior to the maneuver for each of the maneuvers individually during the maneuver (maneuver to be entered here) the PCD value should remain displayed until O/S has steadied on the new leg. Once O/S has steadied the new values of S.A., C.R. and Q.A. should be individually displayed in the performance evaluation data block. Feedback should be provided to the trainee regarding the appropriateness of his maneuver recommendation with re-</p>	<p>2. Understand the value of his maneuver recommendation with respect to the S.A., C.R. and PCD measures.</p>	<p>Operational display TAT operational display</p>

EXERCISE #7 OPTIMUM GEOMETRY

TIME	EVENT	INSTRUCTOR FUNCTION	TRAINEE FUNCTION	DISPLAY
T + 60	Scenario pause	<p>spect to the performance measure values. The trainee should be encouraged to provide the rationale for the recommendation. (This procedure may be carried out at the instructors discretion after any maneuver based on his observations of the ongoing training, i.e., providing feedback where it is required.)</p> <p>6. When the trainee states that the approach objective has been met (terminate) freeze the operational display and review the tactical parameters/performance measures available on the TAT operational display face. As a minimum include:</p> <ul style="list-style-type: none"> <li>a. final performance evaluation block values of PCD, SA, CR and QA.</li> <li>b. system solution data block e.g., <math>C_t</math>, DMh, range, etc.</li> <li>c. sensor data block.</li> <li>d. O/S data block.</li> <li>e. approach objective block.</li> </ul>		TAT operational display
T + 65		<p>7. Request the 3-graph display. Indicate the interactions between parameters. As a minimum:</p> <ul style="list-style-type: none"> <li>a. PCD and range</li> <li>b. PCD and AOB (baffle area, etc.)</li> <li>c. PCD and O/S aspect (NDI, etc)</li> </ul>	<p>3. Understand the parameter interaction over problem time.</p>	Graphing display

EXERCISE #7 OPTIMUM GEOMETRY

TIME	EVENT	INSTRUCTOR FUNCTION	TRAINEE FUNCTION	DISPLAY
T + 75	Terminate scenario	<p>d. PCD and DMh<sup>o</sup>                      e. PCD and DMh<sub>t</sub><sup>o</sup>                      f. SA and O/S aspect                      g. SA and DMh<sup>o</sup>                      h. SA and SNR<sup>o</sup>                      i. CR and yDMh<sup>o</sup>                      j. CR, SA and QA</p> <p>8. Terminate scenario. Hard copy tactical and performance data as appropriate. Conclude scenario.</p>		No display
T + 80	Initialize scenario	<p>9. Repeat steps 1 through 5 for scenario #20. (Scenario #20 is a close range, high SNR, maneuvering target and represents a more difficult tactical encounter. Additionally, counterdetection occurs at approximately T + 12 (scenario time). After T + 12, target maneuvers in response to O/S.</p>	<p>4. Repeat steps 1 and 2.</p>	Operational display TAT operational display
T + 110	Scenario pause	<p>10. Provide delayed performance feedback.</p>	<p>5. Repeat step 3.</p>	Graphing display
T + 120	Terminate scenario	<p>11. Terminate scenario. Hard copy tactical/performance data as required. Conclude exercise.</p>		No display

NAVTRAEQUIPCEN 77-C-0107-1

TRAINING SCENARIOS 1 THROUGH 4

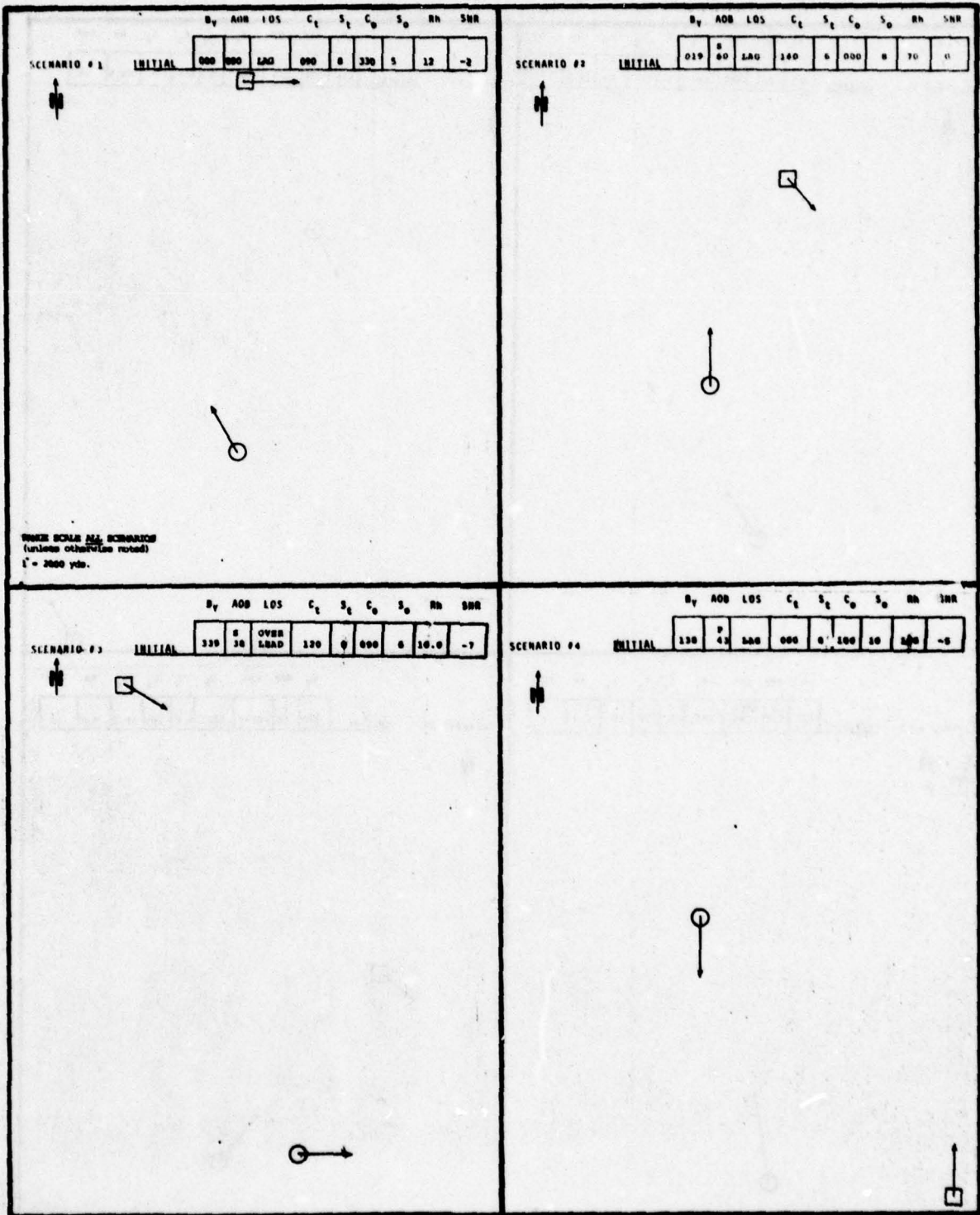

# NAVTRAEQUIPCEN 77-C-0107-1

## TRAINING SCENARIOS 5 THROUGH 8

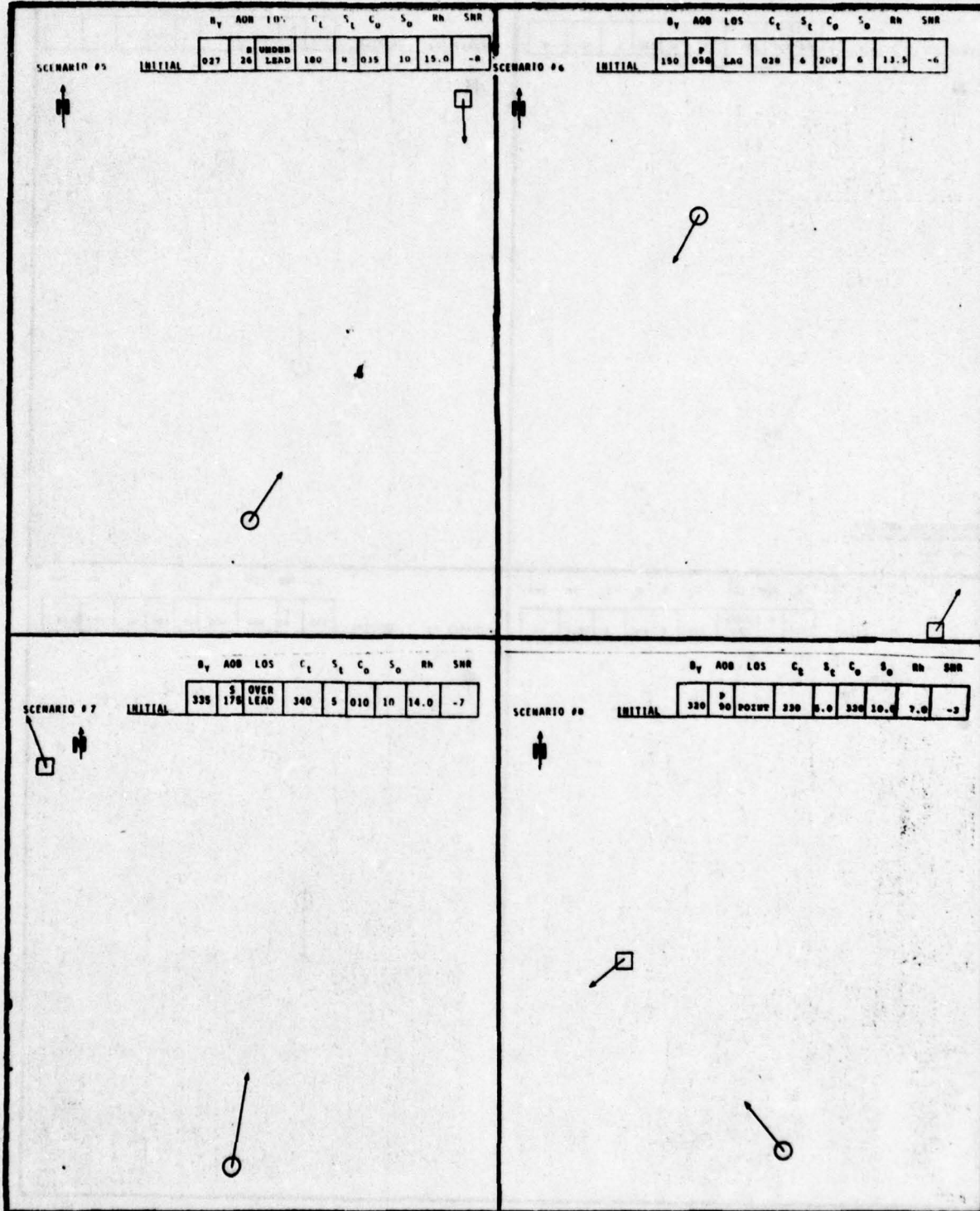

# NAVTRAEQUIPCEN 77-C-0107-1 TRAINING SCENARIOS 9 THROUGH 12

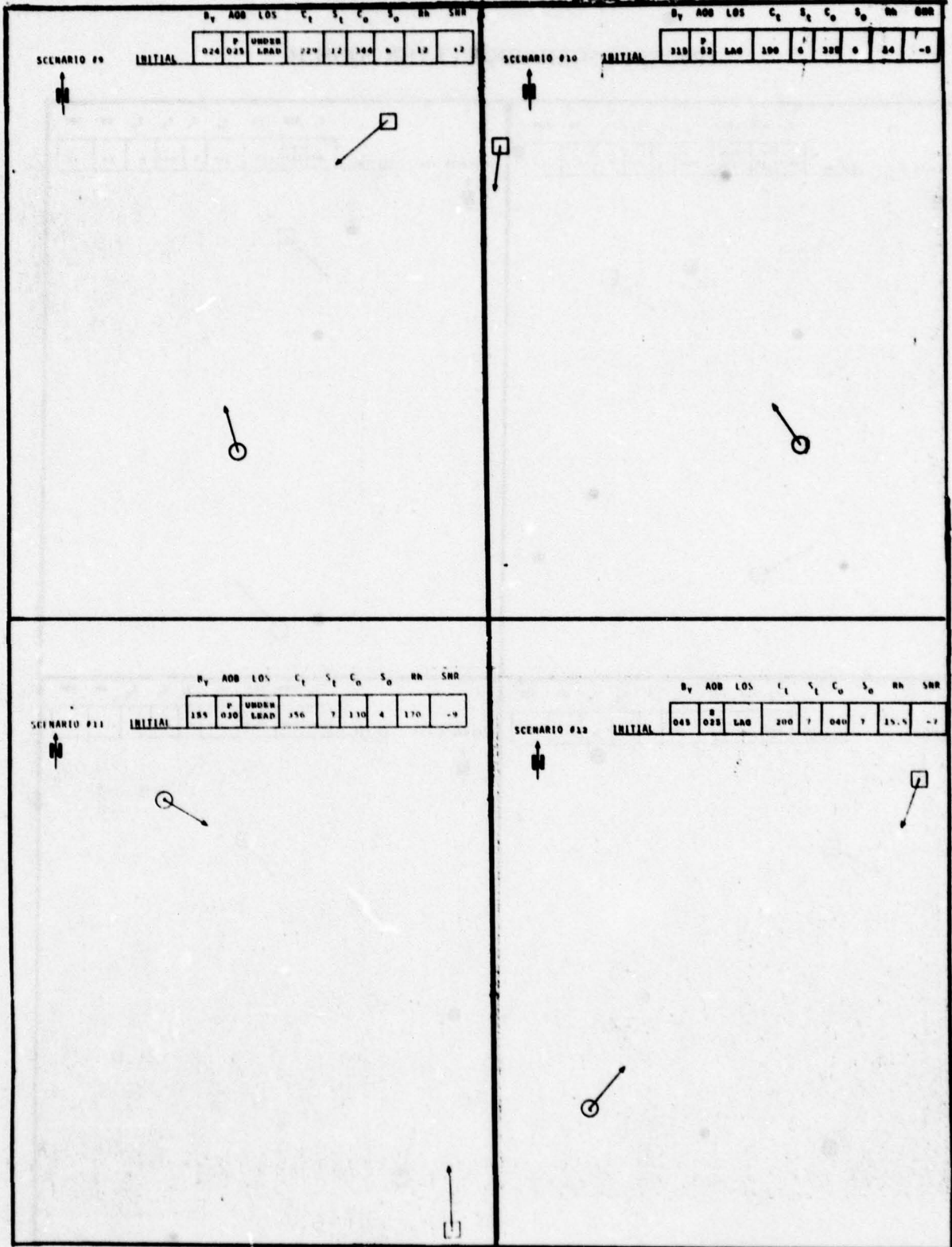

NAVTRAEQUIPCEN 77-C-0107-1

TRAINING SCENARIOS 13 THROUGH 16





NAVTRAEQUIPCEN 77-C-0107-1  
 TRAINING SCENARIO 18

B<sub>y</sub> AOB LOS C<sub>t</sub> S<sub>t</sub> C<sub>0</sub> S<sub>0</sub> Rh SNR

	B <sub>y</sub>	AOB	LOS	C <sub>t</sub>	S <sub>t</sub>	C <sub>0</sub>	S <sub>0</sub>	Rh	SNR
INITIAL(t-0)	008	S 025	POINT	155	15	160	5	48.0	----
MAN <sub>1</sub> (t-4)	001	S 024	LAG	155	15	000	5	46.0	-10
MAN <sub>2</sub> (t-36)	---	---	---	335	5	---	-	---	---
MAN <sub>3</sub> (t-48)	---	---	---	205	5	---	-	---	---
MAN <sub>4</sub> (t-54)	---	---	---	205	15	---	-	---	---

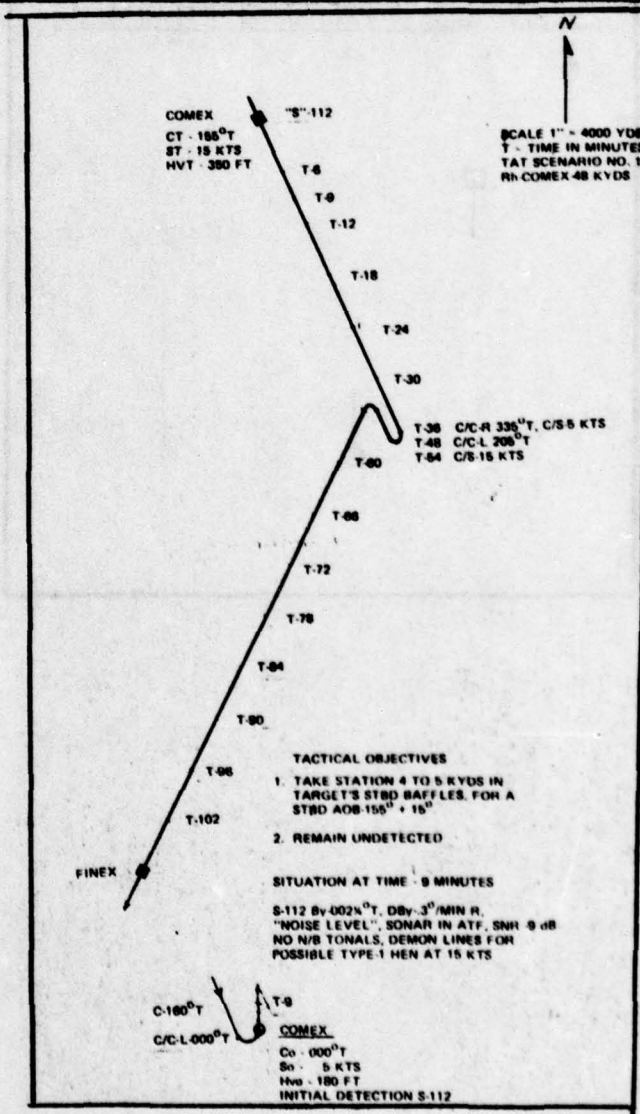

NAVTRAEQUIPCEN 77-C-0107-1  
 TRAINING SCENARIO 19

	$B_y$	AOB	LOS	$C_t$	$S_t$	$C_o$	$S_o$	Rh	SNR
INITIAL( $t_0$ )	355	P30	OVER LEAD	205	15	305	10	23.0	-8
MAN <sub>1</sub> ( $t_{30}$ )	---	---	---	025	7.5	---	--	---	--

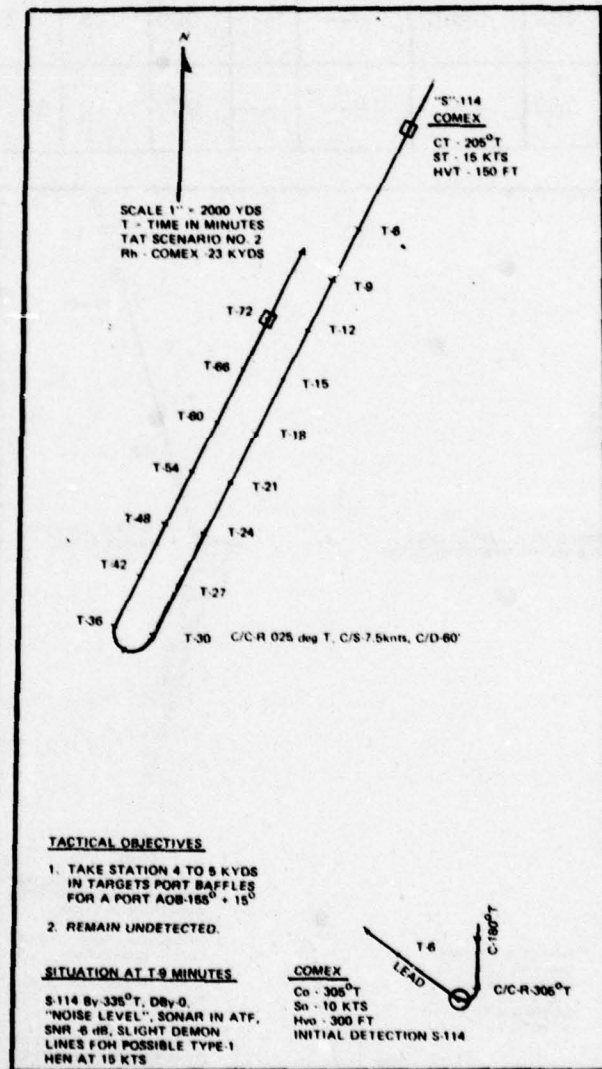

NAVTRAEQUIPCEN 77-C-0107-1

TRAINING SCENARIO 20

	B <sub>y</sub>	AOB	LOS	C <sub>t</sub>	S <sub>t</sub>	C <sub>0</sub>	S <sub>0</sub>	Rh	SNR
INITIAL (t-0)	014	000	OVER TAKING	195	20	190	5	20	-8
MAN <sub>1</sub> (t+9)	013	000	-----	255	4	---	---	17.5	-10
MAN <sub>2</sub> (t+11)	013	P 002	UNDER LEAD	---	---	000	5	17	-2.5
MAN <sub>3</sub> (t+13)	013	P 060	---	---	---	000	10	14.5	-4

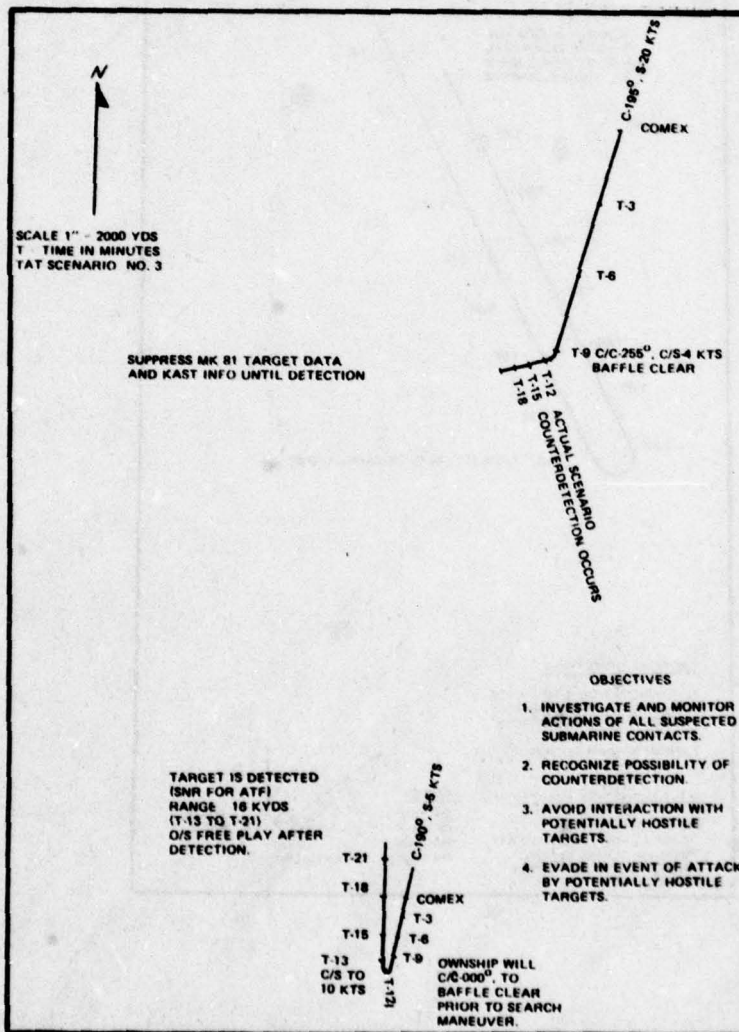

## APPENDIX G

## TRAINING DISPLAYS

TAT Operational Display

The MK 81 Weapon Control Console has a general purpose display and keyboard, capable of presenting a variety of information displays for both operations and maintenance. The tactics mode display, in the geosit submode configuration, had been selected as the context for developing the experimental training simulation and evaluating training assistance technology (see Pesch, Hammell, and Ewalt, 1974). This mode/submode presents a north-up geographical/situation plot of own ship and target tracks, along with relevant alphanumeric information pertaining to own ship actions and the target motion analysis. Figure G-1 presents the TAT operational display, which is an adaptation of the MK 81 WCC tactics mode display. The information presented on the TAT operational display, and its differences with the MK 81 WCC tactics mode display are explained below.

The north-up geographical/situation plot shows own ship's present position as a fixed point (⊙) in the display. Own ship's history track (i.e., own ship's previous positions in time relative to its present position) is shown by a dotted trail (. . .) coming from own ship's present position. The current best estimate of the target's position, relative to own ship's position, is shown by the symbol [x]. This best estimate is based on the designated system solution of TMA, such as the KAST technique. The target's history track, similar to that of own ship, is shown by the trail of Xs emanating from the current target position. Each X represents a sequential update of target position, occurring at selected time intervals (e.g., every three minutes). The target's history track will seldom be as uniform as own ship's, since the quality of the TMA solution continual changes and affects the estimated target position. Often, the target positions early in the TMA will exhibit considerable dispersion, evolving to a uniform track over time as the solution improves.

The own ship and target motion on the display is a combination of true and relative motion. The present own ship's position is fixed north-up with all other points moving in relative motion to this position. This history tracks for own ship and target, however, present a true motion view. All of the target's previous positions (i.e., the current position and the history track) move relative to own ship's present position, resulting in the true motion presentation.

Several capabilities are available on the geographical/situation plot to aid in tactical decision making: (1) range ring can be placed around the present own ship position and set at any desired range, (2) own ship and target actions can be dead reckoned into the future resulting in vectors on the plot to indicated projected positions, and (3) a closest point of approach (CPA) solution can be calculated based on the current own ship and target actions, resulting in vectors emanating from the present own ship and target positions to their respective CPA positions. These capabilities result in corresponding information in the alphanumeric sections of the display.

NAVTRAEQUIPCEN 77-C-0107-1

OWNSHIP CO DMHO HVO TIME	CLOSEST POINT OF APPROACH	MOST RECENT FIDU BY SNR RH EUA TIME SOURCE
	BEARING RANGE TIME	
PERFORMANCE EVALUATION	APPROACH OBJECTIVE	SYSTEM SOLUTION BY - DBY RH CT - DMHT SOURCE
	CURSOR RANGE	

HVT (EST)



Figure G-1. Tactics Mode Display

The alphanumeric information is presented on the upper third of the display. The upper leftmost block presents the present own ship status information: (1) course ( $C_o$ ), (2) speed ( $DMh_o$ ), (3) depth ( $HV_o$ ), and (4) present time. The alphanumeric display area below this block is left blank on the MK 81 WCC tactics mode display. The instructor can insert performance evaluation information in this block on the TAT operation display (e.g., probability of counterdetection). This information would be used to provide feedback and/or cues to the officer trainees.

The upper middle block of information in the TAT operational display presents CPA information corresponding to the geographical situation plot, when the CPA projection is requested. The MK 81 WCC tactics mode display presents the same information, but in the next lower block's position. This display presents sensor status information in the upper middle block (i.e., designated multiple target identification numbers, active versus passive sonar, automatic target following versus manual target tracking). This information is unnecessary for the TAT training exercises. It was replaced with approach objective information which specifies in detail the goals of the exercise. The lower block, cursor range, indicates the selected range value of the variable range ring around own ship.

The two rightmost blocks pertain to the target information being analyzed. The upper rightmost block provides information pertaining to the most recent filtered input data unit (FIDU), the current sonar information. This consists of (1) target bearing ( $By$ ), (2) signal to noise ratio (SNR), (3) target range ( $Rh$ ) in active sonar mode only, (4) depression/elevation angle (EUA), (5) current time, and (6) the information source (e.g., AN/BQS-13 sonar). The lower rightmost block presents the TMA system solution, representing the best estimate of the current target position and actions. It consists of (1) target bearing ( $By$ ), (2) target bearing rate ( $DBy$ ), (3) target range ( $Rh$ ), (4) target course ( $C_t$ ), (5) target speed ( $DMh_t$ ), and (6) information source (e.g., AN/BQS-13 sonar). The estimate target depth ( $HV_t$ ) is presented below these blocks. The target position and actions on the geographical/situation plot correspond to this TMA information.

The TAT operational display, as explained above, is functionally analogous to the MK 81 WCC tactics mode, geographic/situation submode display. Their differences exist in (1) the performance evaluation and approach objective information presented on the TAT operational display, and (2) the sensor status information on the MK 81 WCC tactics mode display.

#### TAT Feedback Displays

Three types of TAT displays provide feedback to the experimental group trainees. The first display provides a knowledge of alternatives to the trainee. The value of the trainee's projected maneuver recommendation is contrasted with the value of a number of alternatives chosen for their training value prior to the training presentation.

The display face is shown in Figure G-2. The topmost data area contains own ship and target tactical information including shared data resulting from the dynamic tactical interaction.

NAVTRAEQUIPCEN 77-C-0107-1

O/S DATA			SHARED DATA			TARGET DATA		
ASPECT	XXX <sup>o</sup>	LD/LG	PCD	XX%		AOB	XXX <sup>o</sup>	LD/LG
Co	XXX <sup>o</sup>		RH	X.X	Kyd	Ct	XXX <sup>o</sup>	
DMHo	XX.X	Kts	By	XXX <sup>o</sup>		DMHt	X.X	Kts
TIME	XXX	Min	DBy	X.XX <sup>o</sup>				
			SNR	XX	db			

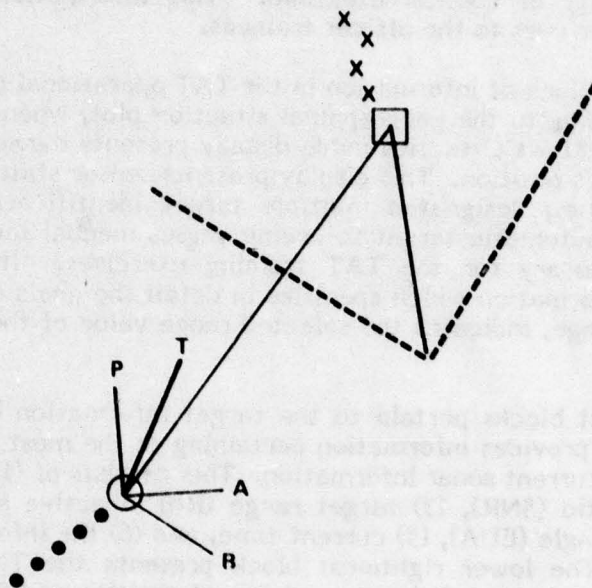

PROJECTION TIME 10.0

ALTERNATIVE	T		P		A		B		
SOL. ACCURACY %	XX		XX		XX		XX		
DBY <sub>n</sub> - DBY <sub>n+1</sub>	X.X		X.X		X.X		X.X		
DBy DEG	X.X		X.X		X.X		X.X		
SNR db	XX		XX		XX		XX		
CQts DEG	XXX		XXX		XXX		XXX		
CLOSING RATE %	XX		XX		XX		XX		
yDMHo Kts	XX.X		XX.X		XX.X		XX.X		
RANGE Kyds	XX.X		XX.X		XX.X		XX.X		
PCD %	XX		XX		XX		XX		

Figure G-2. TAT Alternatives Feedback Display

The center area of the display face shows an own ship track history and target system solution history up to the time of the tactical display freeze which occurs so that the trainee may observe the display and recommend a maneuver. This alternative tactics display provides feedback relative to that maneuvering point by providing a knowledge of the end point values of tactical performance measures. This knowledge is provided for the trainee's projected (10 minute) maneuver vector, a recommended projected maneuver vector, two additional alternative projected vectors and the target's actual projected track vector. These vectors are displayed and visually coded (intensity and labeling; as well as a flashing trainee's vector). The trainee is also provided with not only the quantitative feedback merits of his maneuver relative to specific alternatives but also is provided with qualitative feedback relative to his ability to attain the target end point baffle area (when that is attainable). This is accomplished by dashed line inserts to indicate the target's baffle edges (port and starboard). Additional feedback is provided concerning the merits of the projected maneuver based on the LOS-related information available to the trainee at the maneuver point. This information is provided by a line insert on the display between own ship and target representing the maneuver point line-of-sight. The projection time (which is instructor specified) appears at the bottom right of this display area.

The bottom area of the display face provides end point performance and tactical measure quantitative data (for the performance measure rows) for each of the alternative maneuver columns.

A second TAT feedback display is the multiple X,Y graph display. This more general-purpose display can graph any of the performance or tactical measures over any designated X variable (most generally over time). This enables the trainee to observe the selected measures over the problem run time. In this way the trainee realizes the consequences of his maneuver and its value relative to graphically superimposed values of that performance measure for alternatives maneuvers (the same maneuvers as those displayed on the alternatives display with the same intensity codes described earlier).

The effect of the primary trainee manipulators; i.e., own ship course and speed recommendations can be seen on secondary tactical measures/performance measures; e.g., range, SNR, AOB, PCD, SA, etc, by displaying those performance measures for all alternatives over the same axis problem times. The instructor may discuss the interactions of those variables over time. This is facilitated by the instructor's use of the cursor and the numeric X,Y values displayed to the right of each of the three simultaneously displayed graphs. This display is shown in Figure G-3.

A third display type is the special purpose  $xDMh_t$ -matching display. This display is a variation of the alternative LOS display. The  $xDMh_t$  matching display format is shown in Figure G-4. The own ship, target, and shared data blocks at the top of the display contain the same information found in the alternative LOS display. Additionally, the matching display provides projected (P) information concerning tactical parameters of interest to the  $xDMh_t$ -matching task. These projected (end point) parameter values are indicated directly beneath the data blocks to which they belong, e.g., projected own ship speed across the LOS ( $xDMh_0$ ) is indicated directly beneath the own ship data block.

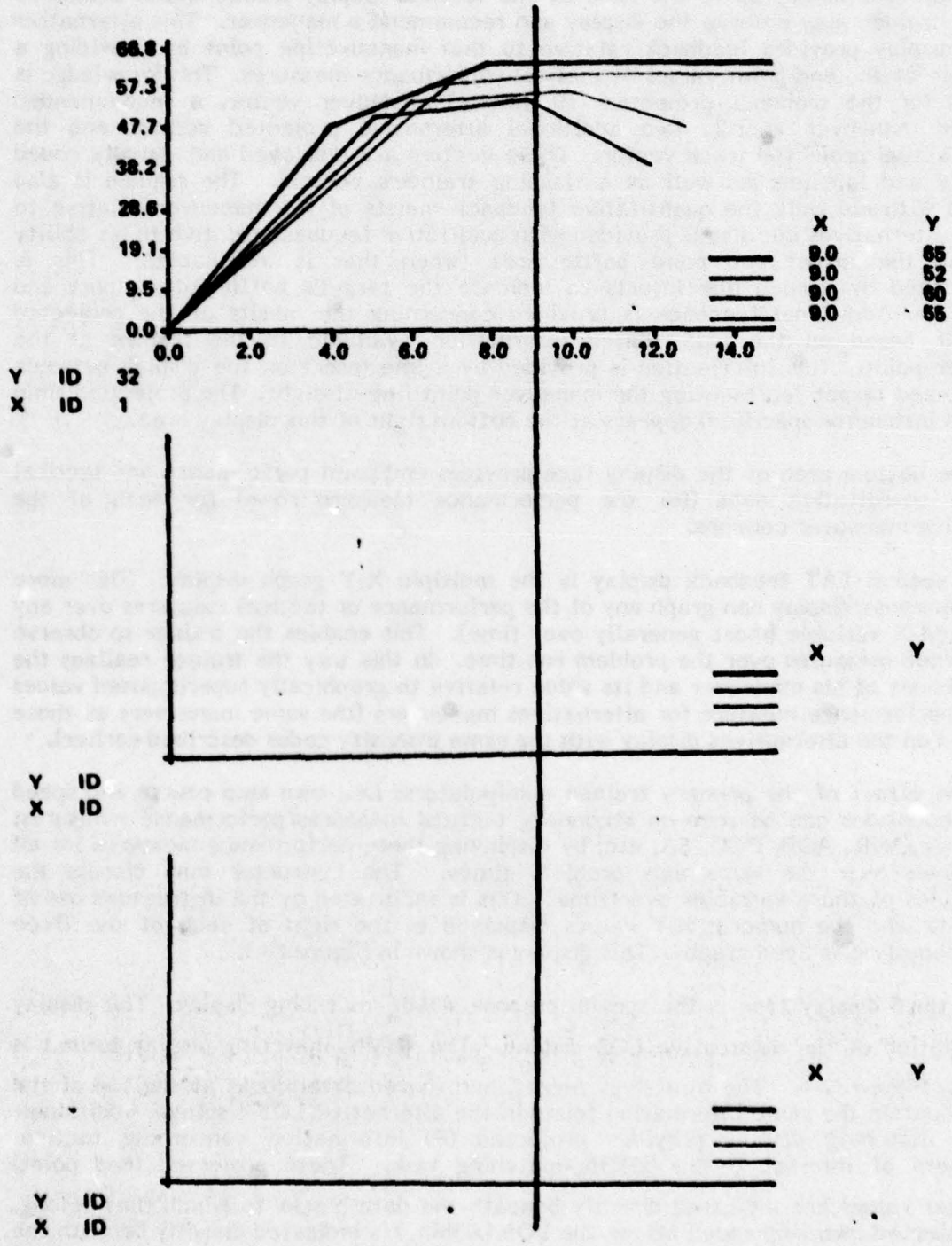

Figure G-3. Multiple X,Y Graph Display

<u>O/S DATA</u>			<u>SHARED DATA</u>			<u>TARGET DATA</u>		
ASPECT	XXX	Deg	PCD	XX	%	AOB	XXX	Deg
Co	XXX	Deg	RANGE	X.X	Kyd	Ct	XXX	Deg
DMHo	XX.X	Kts	By	XXX	Deg	DMHt	X.X	Kts
TIME	XXX	Min	DBy	X.XX	Deg			
			SNR	XX	db			

(P) xDMHo    XX.X  
 (P) Co        XXX.X  
 (P) DMHo    XX.X

(P) DBy      X.X

(P) xDMHt    XX.X

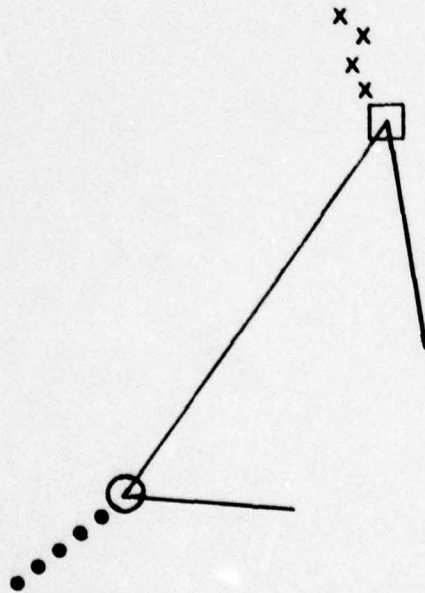

PROJECTION TIME 10.0

Figure G-4. xDMH<sub>t</sub> Matching Display

NAVTRAEQUIPCEN 77-C-0107-1

The tactical display (center display area) indicates target and own ship history tracks (system solution and actual, respectively) and also indicates the LOS between the maneuvering point positions of target and own ship. Since the  $xDMh_t$  matching task requires only a single trainee maneuver and is not trained by providing alternative information, the projected vector displayed are only those for target (assumed nonmaneuvering) and own ship  $xDMh_t$  matching maneuvering recommendation. The maneuver projection time is indicated in the lower left of the display. No alternative column information is provided (as in the alternative LOS display) because the projected (P) tactical values required by the trainee (e.g.,  $DBy$ ,  $xDMh_t$ ,  $xDMh_o$ , etc) are displayed directly beneath the data blocks at the top of the display face.

**APPENDIX H**  
**EXPERIMENTAL GROUP EXERCISE GUIDE**

This appendix contains the instructor's guide used to present the training exercises to the experimental group. The guide details the training process for the demonstration, training scenario presentation, performance feedback, and instruction phases of the exercises. All 10 exercises are presented in the same manner.

EXPERIMENTAL GROUP EXERCISE GUIDE

TIME	EVENT	INSTRUCTOR FUNCTION	TRAINEE FUNCTION	DISPLAY
T-0	Operational display, explanation, demonstration scenario	<p>1. Request operational display (scenario 11). Explain information contained in tactical data blocks of operational display. Include location of:</p> <ul style="list-style-type: none"> <li>a. SNR information</li> <li>b. Range and expected range accuracy</li> <li>c. <math>C_t</math> and <math>C_o</math> information</li> <li>d. <math>DMH_t</math> and <math>DMH_o</math> information</li> <li>e. Sensor type (BQR-7 broadband)</li> <li>f. TMA non-issue</li> </ul> <p>2. Explain training objective in terms of required maneuvering (projection) and performance measures (TMA non-issue). Explain loss of shiphandling at <math>DMH_o</math> 4 knots</p> <ul style="list-style-type: none"> <li>a. State expected trainee performance anticipated tradeoffs of PCD and I.</li> <li>b. Define PCD and I verbally. Indicate effects of primary trainee manipulators; i.e., <math>DMH_o</math> and <math>C_o</math>, on PCD and I.</li> </ul> <p>3. O/S at time 10 maneuver to course <math>190^\circ</math> to the right; speed 7.5 knots.</p> <ul style="list-style-type: none"> <li>a. Explain the value (or lack thereof) of drawing into the target's baffle area.</li> </ul>	<p>1. Understand location of operational display of tactical parameters required for decision-making</p> <p>2. Understand performance required.</p>	Operational



EXPERIMENTAL GROUP EXERCISE GUIDE (CONTINUED)

TIME	EVENT	INSTRUCTOR FUNCTION	TRAINEE FUNCTION	DISPLAY
		<p>6. a. Present and explain the LOS display. Indicate alternatives coding. Identify values as being end point, not time history information.</p> <p>b. Baffle areas defined. <math>120^{\circ}</math> to <math>240^{\circ}</math> relative to target. O/S stern and bow nulls defined as they contribute to PCD and target stern and bow nulls defined as they contribute to PCD and I.</p> <p>c. Projection time defined (10 minutes).</p> <p>7. Specify row performance measures. Specify alternative columns. Interrelate PM, i.e., AOB proj &amp; PCD; DMH &amp; PCD; C<sub>0</sub> &amp; PCD; I &amp; PCD; I &amp; Rh; Rh &amp; C<sub>0</sub>.</p> <p>a. Specify trainee alternative column (T). Review associated performance measures. Indicate end point values only.</p> <p>b. Specify acceptable (P) alternative column. Contrast PM values with trainee alternative values.</p> <p>c. Specify two additional potential maneuvers (A and B). Compare PM values with recommended maneuver values.</p> <p>8. Exit operational program. Request DE-LAY 2 program (3 graph display).</p>	<p>7. Understand time history information as defines "goodness" of various alternatives.</p> <p>8. Understand the tactical variable interactions which drive the performance measures.</p>	

EXPERIMENTAL GROUP EXERCISE GUIDE (CONTINUED)

TIME	EVENT	INSTRUCTOR FUNCTION	TRAINEE FUNCTION	DISPLAY
	(Identify baffle de-crement graphics)	<p>9. Present 3 graph display and explain performance measure diagnostic feedback. Specify keyboard alternatives command. Keyboard request for display of alternative maneuver files. Enter all alternatives for a PM simultaneously.</p> <p>Graph <u>PM</u> ID <u>32</u>            1 <u>PCD<sub>inst.</sub></u>            2 Proj AOB 53            3 DMH<sub>o</sub> 3</p>		
T-0	Begin Scenario 1	<p>10. a. Clear graph 2 and enter, display, and explain the following analytic feedback with respect to its influence on PCD (graph 2):</p> <p>Graph <u>Tact Var</u> ID <u>51</u>            2 <u>Aspect</u></p> <p>b. Clear graph 1 and enter display, and explain the following analytic feedback:</p> <p>Graph <u>PM</u> ID <u>50</u>            1 I</p> <p>c. Clear graph 2 and enter, display, and explain the following diagnostic feedback:</p> <p>Graph <u>PM</u> ID <u>3</u>            2a DMH<sub>o</sub>            2b IP 52</p>	Recommend course and/or speed maneuver.	Operational displays

EXPERIMENTAL GROUP EXERCISE GUIDE (CONTINUED)

TIME	EVENT	INSTRUCTOR FUNCTION	TRAINEE FUNCTION	DISPLAY
T+2		<p>12. Record (paper and pencil) trainee maneuver in course and speed.</p> <p>13. Display LOS feedback via keyboard routine; inserting trainee maneuvering decision when requested. Specify a performance measure rows with deletions. Specify alternative columns.</p> <p>a. Specify trainee alternative column (T). Review associated performance measures. Indicate end point values only.</p> <p>b. Specify recommended alternative column. Contrast PM values with trainee alternative values.</p> <p>c. Specify two additional potential maneuvers. Compare PM values with recommended maneuver values.</p> <p>14. Exit operational program</p> <p>15. Request DELAY 2 program.</p> <p>16. Repeat step 9 (diagnostics feedback).</p> <p>17. Repeat step 10. As required by trainee based on his performance and questions he may have related to his performance.</p>	<p>Understand "goodness" of various alternative relative to own recommendation.</p> <p>Repeat #7</p> <p>Repeat #8</p>	<p>LOS display</p> <p>3 graph display</p>

EXPERIMENTAL GROUP EXERCISE GUIDE (CONTINUED)

TIME	EVENT	INSTRUCTOR FUNCTION	TRAINEE FUNCTION	DISPLAY
T+15		18. Exit DELAY 2 program. 19. Request hardcopy program P DOPER. Record scenario PMs.		
T+18		20. Terminate exercise. 21. Request scenario 2 via keyboard routine. 22. Repeat steps 11 through 19 for scenario 2. 23. Repeat 20 to 21 for scenarios 3 through 10.		

APPENDIX I  
CONTROL GROUP EXERCISE GUIDE

This appendix contains the instructor's guide used to present training exercises to the control group. In general, the guide parallels the functions found in Appendix H. The major differences are: (1) the nature of the performance measure feedback (i.e., quantitative for the experimental and qualitative for the control group); and (2) the method of feedback presentation (i.e., use of specially developed feedback displays for the experimental versus reference to the operational display for the control group).

CONTROL GROUP EXERCISE GUIDE

TIME	EVENT	INSTRUCTOR FUNCTION	TRAINEE FUNCTION	DISPLAY
T-0	Operational display, explanation, demonstration scenario	<p>1. Request operational display. Explain information contained in tactical data blocks of operational display. Include location of:</p> <ul style="list-style-type: none"> <li>a. SNR information</li> <li>b. Range and expected range accuracy</li> <li>c. <math>C_t</math> and <math>C_o</math> information (system solution reliability)</li> <li>d. <math>DMH_t</math> and <math>DMH_o</math> information</li> <li>e. Sensor type (BQR-7 broadband)</li> <li>f. TMA non-issue</li> </ul> <p>2. Explain training objective in terms of required maneuver (projection) and performance measures (TMA non-issue); i.e., data gathering; need a signal which will support information gathering requirements. Explain loss of shiphandling at <math>DMH_o &lt; 4</math> kn.</p> <ul style="list-style-type: none"> <li>a. State expected trainee performance; anticipated tradeoffs of PCD and I.</li> <li>b. Define PCD and I verbally. Indicate effects of primary trainee manipulators; i.e., <math>DMH_o</math> and C , on PCD and I.</li> </ul> <p>3. O/s at time 10 maneuver to course <math>190^\circ</math> to the right; speed 7.5 knots.</p> <ul style="list-style-type: none"> <li>a. Explain the value (or lack thereof) or drawing into the target's baffle area.</li> </ul>	<p>1. Understand location on operational display of tactical parameters required for decision-making.</p> <p>2. Understand performance required.</p>	Operational display

## CONTROL GROUP EXERCISE GUIDE (CONTINUED)

TIME	EVENT	INSTRUCTOR FUNCTION	TRAINEE FUNCTION	DISPLAY
T-0	Feedback description	<p>4. Describe acceptable performance trade-offs. Include verbal description of:</p> <ul style="list-style-type: none"> <li>a. Acceptable requires small speed increase to enter baffles. Med. range; crossing.</li> <li>b. Acceptable does not include baffle entry. Required own ship speed too high. Meeting geometry, 90 AOB.</li> <li>c. Acceptable requires reduction in o/s speed. Maneuver point is in target baffles PCD is already near min.</li> <li>d. Acceptable requires DMH unchanged, with the C maneuver Variable. Overtaking geometry.</li> </ul> <p>5. Indicate to the subject that he will be told after each maneuver recommendation whether his value for counterdetection exceeded or not the 50% probability of counterdetection value predicted by the range-of-the-day.</p> <p>6. Additionally, the subject must be informed when I is achieved. I should be referenced to end point SNR. IP should be discussed as an equally weighted summary measure.</p>	4. Understands location of target baffles.	

CONTROL GROUP EXERCISE GUIDE (CONTINUED)

TIME	EVENT	INSTRUCTOR FUNCTION	TRAINEE FUNCTION	DISPLAY
T-0	Initialize Scenario	7. Indicate to the trainee that he will be allowed to ask questions concerning the performance measures, subject's behavior relative to those performance measures, clarification of tactical information already displayed, etc. (The absolute feedback period is 10 minutes; however, a trainee has the option of terminating the feedback session and proceeding to the next training scenario.)		
T+2	Terminate Scenario	8. Request scenario 1 via keyboard routine. 9. Record (paper and pencil) trainee maneuver recommendation.		
T+10	Feedback	10. Provide feedback as outlined in the pre-scenario feedback demonstration. Terminate feedback session after 10 minutes. 11. Request hardcopy program P DOPER. Record scenario PMs.		
T+12	Initialize Scenario	12. Repeat above for scenarios 2 through 10.		

APPENDIX J

TAT EXPERIMENTAL EVALUATION SCENARIOS

I. SCENARIO DESIGN VARIABLES

(Randomized with regard to inclusion in training scenario order of presentation)

- a. Maneuvering point range to target
- b. Maneuvering point AOB
- c. Initial bearing to target
- d. Initial o/s aspect e.g., underlead, overlead, or lag geometry. Random selection of o/s courses w/i those closing quadrants

II. DECISION CATEGORIES FOR SCENARIO TACTICAL SOLUTION

- a. In target baffles at maneuvering point; baffles =  $120^{\circ}$  -  $240^{\circ}$  (relative to target)
  - 1) PCD is near minimum at maneuver.
  - 2) I is always increased by an increase in SNR, i.e., for a non-maneuvering target a decrease in o/s speed.
  - 3) Target receives least signal from o/s when presented with o/s bow or stern nulls (See PCD mod. algorithm). Highest signal on beam.
  - 4) O/s receives least signal from target bow or stern nulls (See SNR mod. algorithm). Highest signal on beam).
- b. On edge of target baffles at maneuvering point
  - 1) Target baffle entry ( $120^{\circ}$  -  $240^{\circ}$ ) reduces PCD most significantly.
  - 2) An increase in o/s speed to enter baffles will increase PCD initially (until baffle entry) and will always decrease I (inversely proportional).
  - 3) An early baffle entry may warrant an initial increase or continuation of o/s maneuvering point speed.
  - 4) Aspect and AOB listening considerations in force.
- c. Out of target baffles; baffles unattainable
  - 1) Maneuver for low PCD
    - a) Decrease speed if range is relatively short (this causes an increase in I, also).
    - b) A speed increase will provide much too high PCD due to range to baffles.
    - c) Maneuver o/s to take advantage of o/s & target bow and stern nulls.

# NAVTRAEQUIPCEN 77-C-0107-1

## SCENARIOS 1 THROUGH 4

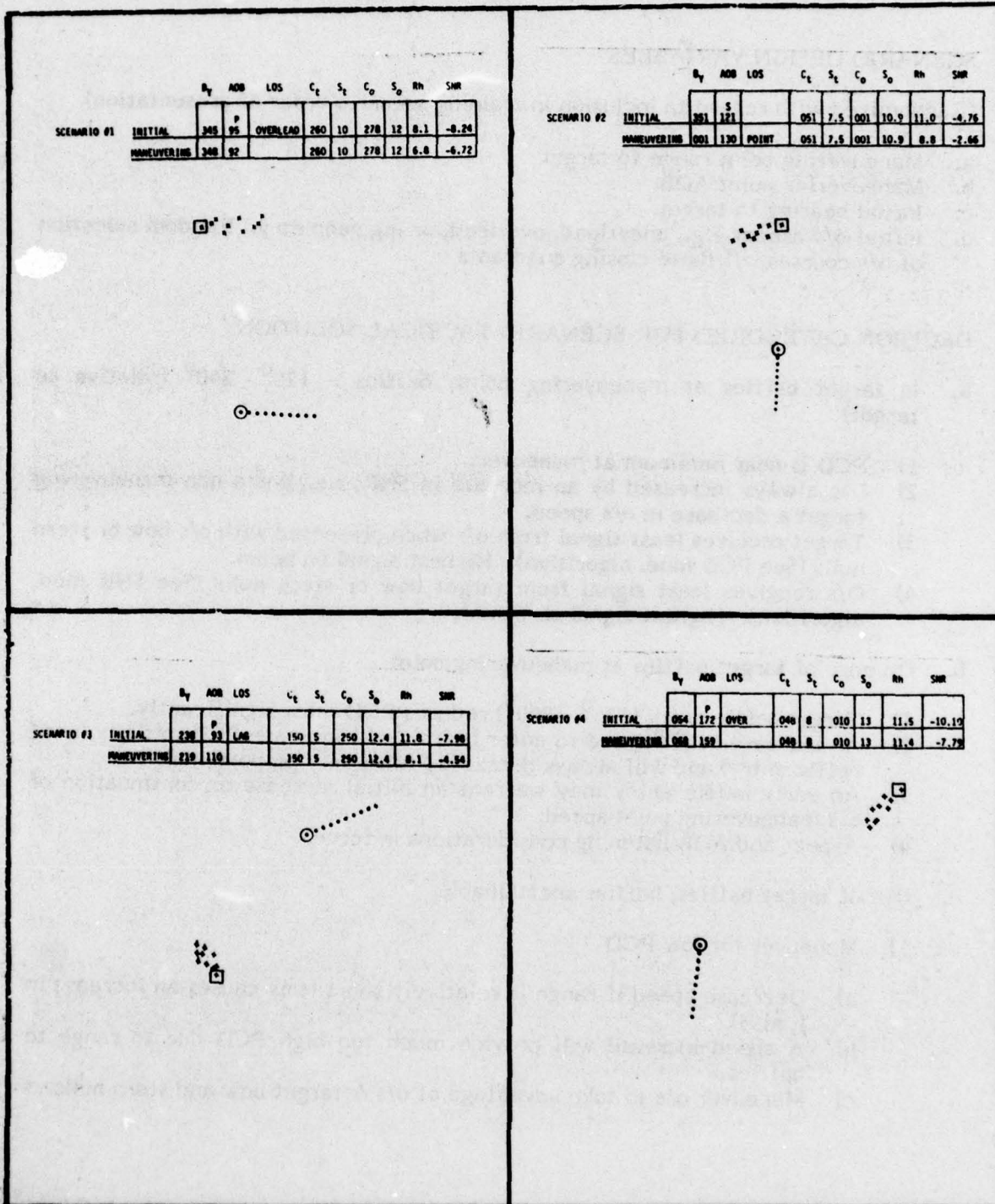

NAVTRAEQUIPCEN 77-C-0107-1

SCENARIOS 5 THROUGH 8

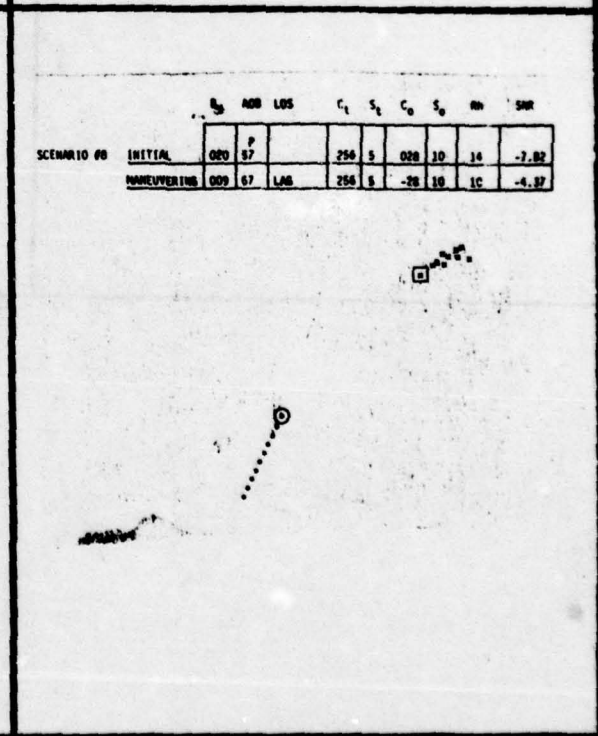
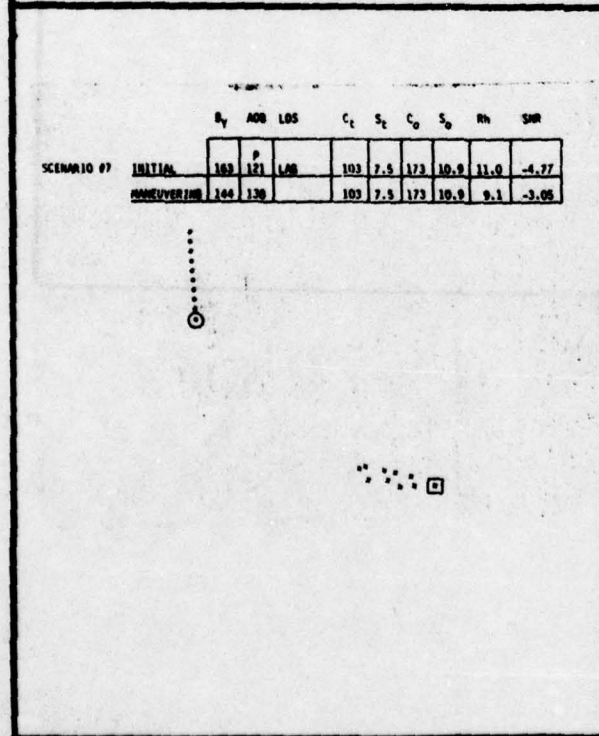
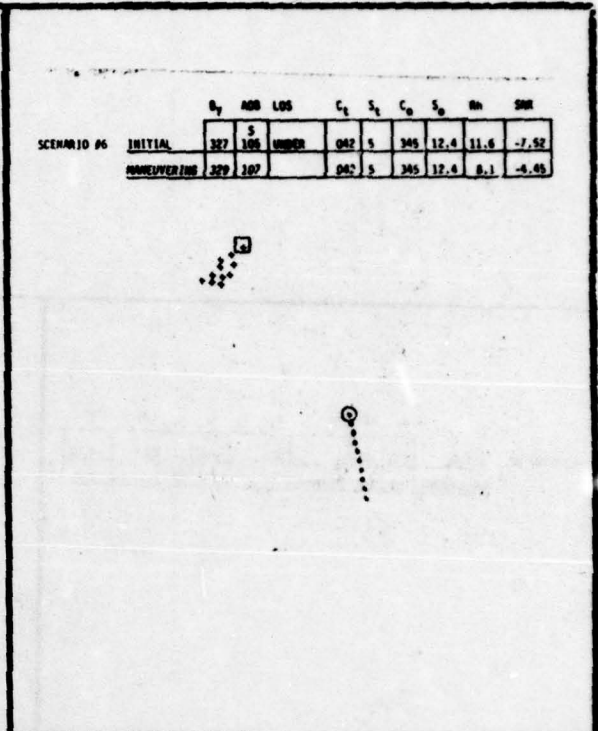
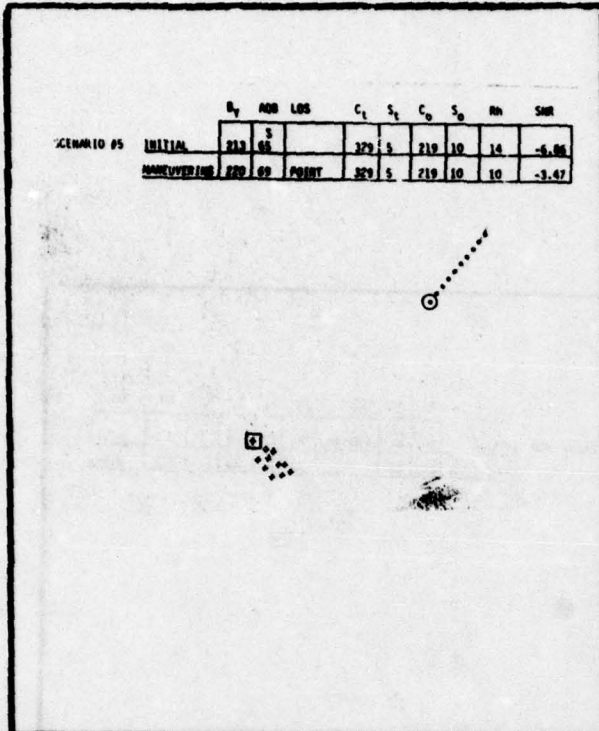

NAVTRAEQUIPCEN 77-C-0107-1  
 SCENARIOS 9 THROUGH 10

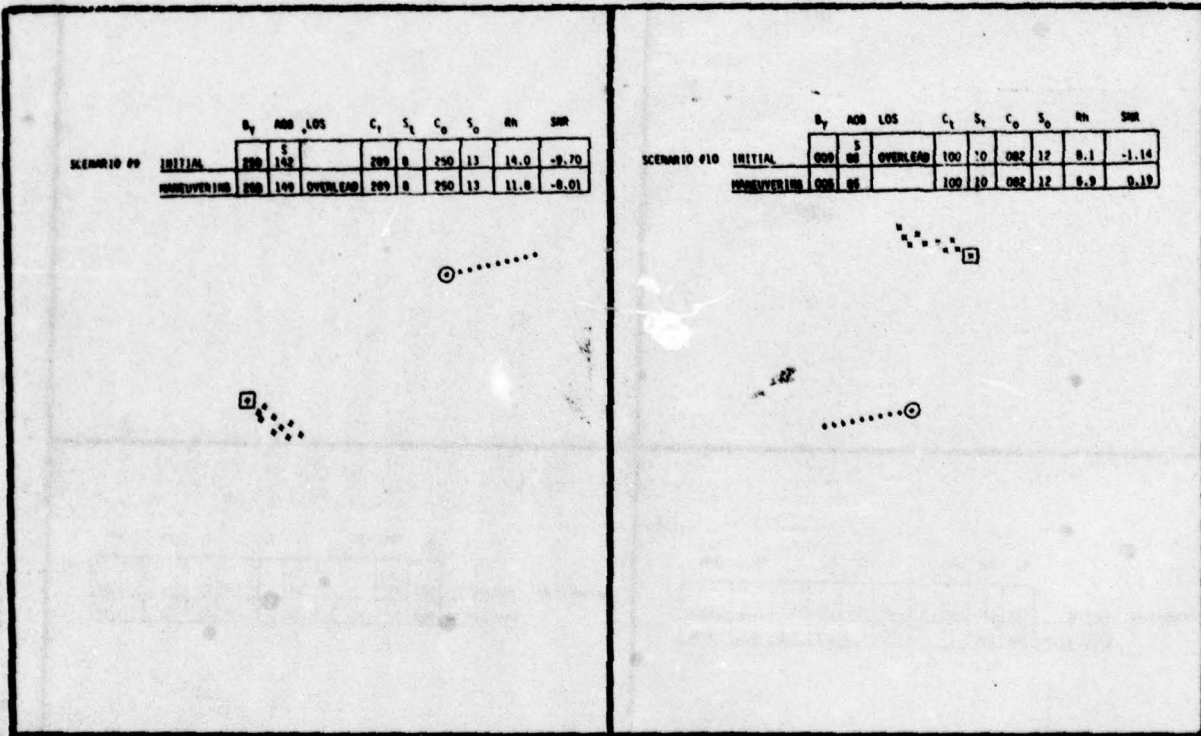

APPENDIX K

TRAINEE INPUT CHARACTERISTICS (TCR)

Trainees generally were operating at either a basic or intermediate level of tactical expertise. Greater than 80 percent of the trainees were ranked LT or below, however, the mode was LCDR (5).

Formal tactical training most often meant completing only the Submarine Officers Basic Course (prerequisite for sea duty). This formal training was generally followed by an SSBN assignment where the trainees gained operational experience on the MK 113/9 FCS with the MK 78 CRT tactical display. Some trainees (5) were experienced/acquainted with the MK 113/10 or MK 117 (the MK 81 CRT display subsystem). A TCR experimental observation was that, regardless of their familiarity and the detailed explanations provided, all subjects required a minimum of at least one scenario to understand how to use the display information. Observations in the SOAC curriculum prior to conducting the experiment indicated that the curriculum emphasized objectives that required a knowledge of the MATE display mode with little reference to the usefulness of the MK 81 GEOSIT submode as an approach tool (nonavailable software support was the major factor here).

Sea duty varied greatly. While all subjects had spent some time at sea, in a few cases that time was less than 6 months. The largest average sea duty was aboard SSBNs. Two of the subjects were tactics training course instructors (SOAC and PXO, PCO) and two other subjects are presently assigned to submarine support activities (training and certification programs) not forces afloat. Seven of the remaining eight subjects were attached to forces afloat. The final subject was a retired submarine officer currently engaged by EA. This subject, not assigned to tactics development or tactics training development, was naive of the TAT objectives and brought no advantage due to his employment by EA to the experimental evaluation. He furthermore served as control group subject.

This biographical information is summarized in Table K-1.

TABLE K-1. DEMOGRAPHIC INFORMATION (12 SUBJECTS)

1.	<u>Rank</u>	<u>ENS</u>	<u>LTJG</u>	<u>LT</u>	<u>LCDR</u>
		2	2	3	5

50 percent LT or below

2. Formal Tactical Training

MK 113/10 FAM	1	PXO	3*
SOBC	9	PCO	3
SOAC	4*	NONE	1

\*Two of the subjects were instructors. 1 for SOAC and 1 for PXO, PCO trainees

3. FCS Operational Experience

MK 113/6	2	MK 113/9	9
MK 113/7	1	MK 113/10	4
MK 113/8	3	MK 117	1

Additionally a few (3) subjects had experience on earlier FCS; e.g., MK 106

4. CRT Tactical Display Experience

MK 78	9	MK 81	5
-------	---	-------	---

5. Sea Duty

<u>SSBN</u>		<u>SSN</u>		<u>SS</u>	
Range	Mean	Range	Mean	Range	Mean
0-105	32	0-40	8	0-108	18

## GLOSSARY

AAO	Assistant approach officer
AO	Approach officer
AOB	Angle on the bow
By	Bearing
CAT	Computer assisted training
$C_o$	Own ship course
COMEX	Commence exercise
COTD	Commanding Officers Tactical Display
CPA	Closed point of approach
$Cqt_o$	Own ship aspect
$Cqt_s$	Target angle on the bow
CR	Closing rate performance measure
$C_t$	Target course
DBy	Bearing rate
$ DBy_n - DBY_{n+1} $	Absolute change in bearing rate over two maneuver legs
DE	Dynamic exercises
EUA	Apparent Depression Angle
FAM	Familiarization (MK 113/10) course
FCC	Fire control coordinator
FIDU	Filtered input data unit
FINEX	Finish exercise
FTG	Fire control technician specialty rating
I	Information quality performance measure
ICP	Closing rate in the line of sight
IP	Information UI & PCD, a summary performance measure
KAST	Kalman automatic sequential TMA
KICO	Classified tactical operations
LOS	Line of sight
MATE	Manual adaptive TMA evaluator
MPS	Multi-purpose sonar system
NAVOP	Staff of Chief of Naval Operations

NAVTRAEQUIPCEN 77-C-0107-1

NAVTRAEQUIPCEN	Naval Training Equipment Center
NFM <sub>t</sub>	Figure of merit, target
NLON	New London, CT
NORVA	Norfolk, VA
NPRDC	Naval Personnel Research and Development Center
NSE <sub>o</sub>	Signal excess, own ship
O/S	Own ship
PCD	Probability of counterdetection performance measure
PCO	Prospective Commanding Officer training course
PREDEP	SSN mission predeployment training
PXO	Prospective Executive Officer training course
REFTRA	SSN crew refresher training
QA	Quality of approach performance measure
Rh	Range
SA	Solution Accuracy Performance Measure
SCST	Submarine Combat Systems Trainer
SF	Scale factor
SNR	Signal-to-noise ratio
S <sub>o</sub>	Own ship speed
SOAC	Submarine Officer Advanced Course
SOBC	Submarine Officer Basic Course
SSBN	Nuclear Ballistic Missile Submarine
SSN	Nuclear Attack Submarine
S <sub>t</sub>	Target speed
SUBTOM	Submarine Tactical Operations Model
TA	Track angle
TAT	Training assistance technology
TMA	Target motion analysis
TS	Time to station performance measure
TUBA	Data gathering sonar system
UFCS	Underwater fire control system
WATE	Weapons attack evaluation mode (MK 81)
WCC	Weapons control console
xDMh <sub>o</sub>	Own ship speed across the LOS

NAVTRAEQUIPCEN 77-C-0107-1

$xDMh_r$   
 $xDMh_t$   
 $yDMh_o$   
 $yDMh_r$   
 $yDMh_t$

Relative speed across the LOS  
Target speed across the LOS  
Own ship speed in the LOS  
Relative speed in the LOS  
Target speed in the LOS

NAVTRAEQUIPCEN 77-C-0107-1

Defense Documentation Center  
Cameron Station  
Alexandria, VA 22314

Commanding Officer  
Naval Training Equipment Center  
Orlando, FL

Eclectech Associates, Inc.  
P. O. Box 178  
North Stonington, CT 06359

All other addressees receive one copy

Chief of Naval Operations  
OP-987H  
Attn: Dr. R. G. Smith  
Washington, DC 20350

Chief of Naval Research  
Code 458  
Arlington, VA 22217

Commanding Officer  
Fleet Combat Training Center Pacific  
Code 09A  
San Diego, CA 92147

Chief of Naval Education and Training  
Code N-2  
Attn: CAPT Bauchspies  
NAS  
Pensacola, FL 32508

Director Educational Development  
Academic Computing Center  
U. S. Naval Academy  
Annapolis, MD 71402

US Air Force Human Resources Lab  
DOJZ  
Brooks AFB, TX 78235

US Air Force Human Resources Lab  
AFHRL-TT (Dr. Rockway)  
Technical Training Division  
Lowry AFB, CO 80230

Chief of Naval Operations  
OP-102X  
Washington, DC 20350

Headquarters  
Air Training Command, XPTI  
12 Attn: Mr. Goldman  
Randolph AFB, TX 78148

ASD SD24E  
30 Attn: Mr. Harold Kottmann  
Wright Patterson AFB, OH 45433

USAHEL/USAAVNC  
10 Attn: DRXHE-FR (Dr. Hoffmann)  
P. O. Box 476  
Ft. Rucker, AL 36362

Dr. Jesse Orlansky  
Institute for Defense Analyses  
Science and Technology Division  
400 Army-Navy Drive  
Arlington, VA 22202

Director  
Human Resources Research Organization  
300 N. Washington Street  
Alexandria, VA 22314

Grumman Aerospace Corp.  
Plant 36  
Attn: Mr. Sam Campbell  
Bethpage, LI, NY 11714

Dr. E. Cohen  
Link Division  
The Singer Co.  
Binghamton, NY 13902

Dr. Edward A. Stark  
Link Division  
The Singer Co.  
Binghamton, NY 13902

ERIC/IR  
Syracuse University  
School of Education  
Syracuse, NY 13210

Scientific Technical Information Office  
NASA  
Code NST-44  
Washington, DC 20546

Seville Research Corp.  
Suite 400, Plaza Building  
Pace Boulevard at Fairfield  
Pensacola, FL 32505

NAVTRAEQUIPCEN 77-C-0107-1

Commandant  
USA Field Artillery School  
Target Acquisition Dept.  
Attn: Eugene C. Rogers  
Ft. Sill, OK 73503

Commanding Officer  
Fleet Anti-Submarine Warfare Training  
Center, Pacific  
Attn: Code 001  
San Diego, CA 92147

Chief of Naval Education and Training  
Liaison Office  
Human Resources Laboratory  
Flying Training Div. (Attn: CAPT W. C. Mercer)  
Williams AFB, AZ 85224

US Air Force Human Resources Lab  
AFHRL-AS  
Advance Systems Division  
Wright-Patterson AFB, OH 45433