

AD-A072 062

HONEYWELL INC MINNEAPOLIS MN SYSTEMS AND RESEARCH CENTER F/G 6/17
VISOR FABRICATION PROCESS STUDY.(U)

JUL 79 J PRICE

F33615-72-C-0420

UNCLASSIFIED

2079-SR2

AMRL-TR-79-63

NL

| OF |

AD
A072062



END
DATE
FILMED
9-79

DOC

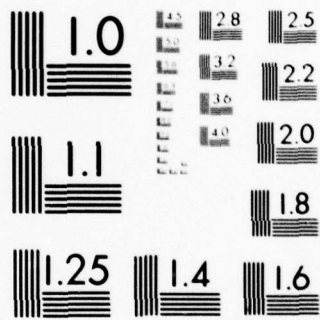

MICROCOPY RESOLUTION TEST CHART
NATIONAL BUREAU OF STANDARDS-1963-A

AD A 072062

AMRL-TR-79-63



VISOR FABRICATION PROCESS STUDY

J. PRICE

Honeywell Systems and Research Center
2700 Ridgway Parkway
Minneapolis, Minnesota 55413

JULY 1979

Approved for public release; distribution unlimited

AEROSPACE MEDICAL RESEARCH LABORATORY
AEROSPACE MEDICAL DIVISION
AIR FORCE SYSTEMS COMMAND
WRIGHT-PATTERSON AIR FORCE BASE, OHIO 45433

79 07 31 047

DDC ACCESSION NUMBER



LEVEL

DATA SHEET

PHOTOGRAPH

THIS SHEET

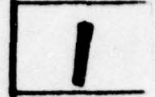

INVENTOR

AMRL-TR-79-63

DOCUMENT IDENTIFICATION

DISTRIBUTION STATEMENT A

Approved for public release;
Distribution Unlimited

DISTRIBUTION STATEMENT

Accession For	
NTIS GRA&I	<input checked="" type="checkbox"/>
DDC TAB	<input type="checkbox"/>
Unannounced	<input type="checkbox"/>
Justification	<input type="checkbox"/>
By _____	
Distribution/ _____	
Availability Codes	
Dist	Avail and/or special
A	

DISTRIBUTION STAMP

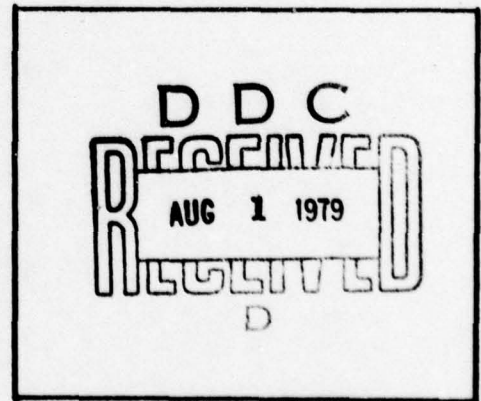

DATE ACCESSIONED

79 07 31 047

DATE RECEIVED IN DDC

PHOTOGRAPH THIS COPY

NOTICES

When US Government drawings, specifications, or other data are used for any purpose other than a definitely related Government procurement operation, the Government thereby incurs no responsibility nor any obligation whatsoever, and the fact that the Government may have formulated, furnished, or in any way supplied the said drawings, specifications, or other data, is not to be regarded by implication or otherwise, as in any manner licensing the holder or any other person or corporation, or conveying any rights or permission to manufacture, use, or sell any patented invention that may in any way be related thereto.

Please do not request copies of this report from Aerospace Medical Research Laboratory. Additional copies may be purchased from:

National Technical Information Service
5285 Port Royal Road
Springfield, Virginia 22161

Federal Government agencies and their contractors registered with Defense Documentation Center should direct requests for copies of this report to:

Defense Documentation Center
Cameron Station
Alexandria, Virginia 22314

TECHNICAL REVIEW AND APPROVAL

AMRL-TR-79-63

This report has been reviewed by the Information Office (OI) and is releasable to the National Technical Information Service (NTIS). At NTIS, it will be available to the general public, including foreign nations.

This technical report has been reviewed and is approved for publication.

FOR THE COMMANDER

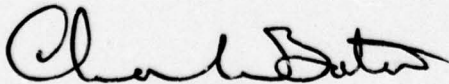

CHARLES BATES, JR.
Chief
Human Engineering Division
Aerospace Medical Research Laboratory

79 07 31 047

UNCLASSIFIED

SECURITY CLASSIFICATION OF THIS PAGE (When Data Entered)

REPORT DOCUMENTATION PAGE		READ INSTRUCTIONS BEFORE COMPLETING FORM
1. REPORT NUMBER AMRL-TR-79-63	2. GOVT ACCESSION NO.	3. RECIPIENT'S CATALOG NUMBER
4. TITLE (and Subtitle) VISOR FABRICATION PROCESS STUDY	5. TYPE OF REPORT & PERIOD COVERED Technical Report	
	6. PERFORMING ORG. REPORT NUMBER 2079-SR2	
7. AUTHOR(s) J. Price	8. CONTRACT OR GRANT NUMBER(s) F33615-72-C-0420/PZ0002	
9. PERFORMING ORGANIZATION NAME AND ADDRESS Honeywell Systems and Research Center 2700 Ridgway Parkway Minneapolis, Minnesota 55413	10. PROGRAM ELEMENT, PROJECT, TASK AREA & WORK UNIT NUMBERS 5973	
11. CONTROLLING OFFICE NAME AND ADDRESS Aerospace Medical Research Laboratory, Aerospace Medical Division, Air Force Systems Command, Wright-Patterson Air Force Base, Ohio 45433	12. REPORT DATE 11 July 1979	
	13. NUMBER OF PAGES 65	
14. MONITORING AGENCY NAME & ADDRESS (if different from Controlling Office)	15. SECURITY CLASS. (of this report) UNCLASSIFIED	
	15a. DECLASSIFICATION/DOWNGRADING SCHEDULE	
16. DISTRIBUTION STATEMENT (of this Report) Approved for public release; distribution unlimited		
17. DISTRIBUTION STATEMENT (of the abstract entered in Block 20, if different from Report)		
18. SUPPLEMENTARY NOTES		
19. KEY WORDS (Continue on reverse side if necessary and identify by block number)		
20. ABSTRACT (Continue on reverse side if necessary and identify by block number)		

UNCLASSIFIED

CONTENTS

		Page
SECTION I	INTRODUCTION	1-1
SECTION II	SUMMARY	2-1
SECTION III	TECHNICAL DISCUSSION	3-1
	Fabrication Process Study	3-1
	Visor Testing	3-6
	Mold Development	3-13
	Process Development	3-21
	Vacuum Forming: 1-1/2-inch Mold	3-23
	Compression Molding: 1-1/2-inch Mold	3-24
	Improved Vacuum Forming	3-25
	Development with 2-inch Mold	3-35
	Shaping the Visor	3-42
APPENDIX A	DETAILED OPERATING PROCEDURE FOR VISOR BLANK FORMING	

ILLUSTRATIONS

Figure		Page
1-1	Mod 7A Visor - Sk58932-1	1-3
1-2	Mod 7A Visor Blank - Sk58932-2	1-4
1-3	Visor Notes - SK58932-3	1-5
3-1	Ray Trace - Mod 7A Visor	3-7
3-2	Visor Evaluation Fixture	3-8
3-3	Resolving Power Test Target	3-9
3-4	Baseline Image	3-10
3-5	Image from Mod 6 Visor	3-11
3-6	Image from Visor Blank Molded on Rough Mold	3-12
3-7	Image from Visor Blank Molded on Polished Mold	3-14
3-8	Image from Best Visor Blank Molded on Polished Mold	3-15
3-9	Indiron Data - 1-1/2-inch Mold	3-16
3-10	Mold - 2-inch Parabolic Mold	3-18
3-11	Two-inch Mold Showing Indiron Test Data Points	3-19
3-12	Indiron Data - Two-inch Mold	3-20
3-13	Image from Two-inch Mold	3-22
3-14	Double-Vacuum Fabrication System	3-27
3-15	Double-Vacuum System in Space Chamber	3-28
3-16	Closed Vacuum Forming System	3-30
3-17	Vacuum Forming Fixture Base with Mold	3-31
3-18	Inverted Mold Configuration	3-33

3-19	Visor Forming Cycle (1-1/2 Parabola)	3-34
3-20	Comparison of Mold Shapes	3-35
3-21	Change in Plastic Sheet During Forming	3-37
3-22	Cross-Sectional Area Considerations	3-39
3-23	Plastic Sheet - Machining for 7A Visor Fab	3-40
3-24	Sheet Thinning Comparison	3-41
3-25	Visor Cut-out/Drill Fixture	3-43

TABLES

Table		Page
3-I	Candidate Visor Material	3-2
3-II	Material Selection Matrix	3-3
3-III	Process Selection Matrix	3-5
3-IV	Summary of Visor Thinning Data	3-36

SECTION I INTRODUCTION

The advent of the IHMS/D program introduced the problem of providing a suitable visor. Honeywell had previously fabricated visors for optical display systems such as the single-bounce, reticle projection system. Honeywell also designed and fabricated a prototype double-bounce display system (Model 6).

The one critical area, common to both reticle and video display visor projection techniques, was the development of a plastic parabolic visor. Seventeen different approaches for fabricating plastic paraboloids were considered over a period of a year and a half.

The first step of the parabolic fabrication procedure selected for the Model 6 visor was to generate a true parabolic cam for the inside of the parabolic visor. This cam was then used to cut an aluminum male mold for vacuum-forming acrylic blanks. These blanks were then annealed and potted into female molds which were also machined from the original cam. The potted parabolic section was then rough-machined to the approximate parabolic shape and delivered to Hoeger Optical Company of Chicago for final cutting and polishing to a parabolic shape. After polishing, the blank was removed from the mold and cut to shape.

Sides were then cemented to the visor to facilitate mounting to a helmet. However, the paraboloids were not perfect and the image quality was poor because of see-through distortion, prismatic deviation, and boresight instability. Since each visor was individually machined, quality varied considerably from one unit to the next. Since only one or two visors were required for Model 6, the machining technique was marginally satisfactory.

For the IHMS/D program, the problem was different. First of all, many more visors were required of a high, uniform quality. Further, a smoothly contoured, one piece unit was required. The visor configuration established for the LG1083AA01* Integrated Helmet Mounted Sight/Display (Model 7A) is illustrated by Figure 1-1 (SK58932 Sheet 1). The blank from which the visor is cut is shown as Figure 1-2 (SK58932 Sheet 2). Sheet 3 of the drawing (Figure 1-3) covers the appropriate notes. These requirements necessitated a new technique for fabricating the visor. Consequently, the effort described in this report was initiated.

*The LG1083AA01 IHMS/D unit has been designated Mark I, Mod I by the United States Air Force, and will be so designated throughout the remainder of this report.

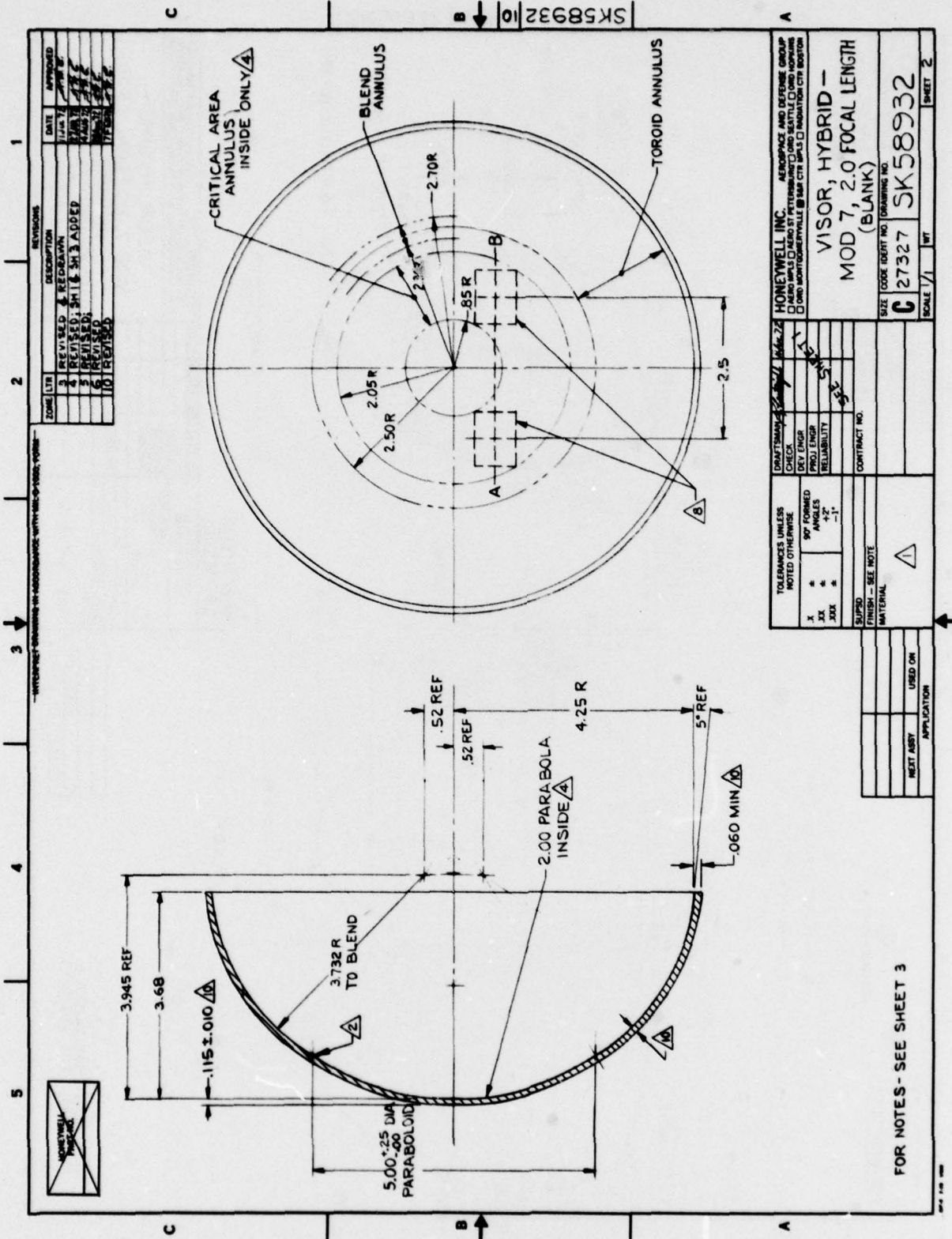

ZONE	DATE	DESCRIPTION	APPROVED
1	1/16/71	REVISED & REDRAWN	J.P.F.
2	1/16/71	REVISED, WHITE SHADDED	J.P.F.
3	1/16/71	REVISED	J.P.F.
4	1/16/71	REVISED	J.P.F.
5	1/16/71	REVISED	J.P.F.
6	1/16/71	REVISED	J.P.F.
7	1/16/71	REVISED	J.P.F.
8	1/16/71	REVISED	J.P.F.
9	1/16/71	REVISED	J.P.F.
10	1/16/71	REVISED	J.P.F.

HONEYWELL INC. AEROSPACE AND DEFENSE GROUP 1400 MASS BLVD. ST. PETERSBURG, FLORIDA 33701 <input type="checkbox"/> 4800 MONTGOMERY AVENUE, BIRMINGHAM, ALABAMA 35215 <input type="checkbox"/> 600 MONTELEONE AVENUE, HOUSTON, TEXAS 77001 <input type="checkbox"/> 1000 WASHINGTON AVENUE, NEW YORK, NEW YORK 10036	
VISOR, HYBRID - MOD 7, 2.0 FOCAL LENGTH (BLANK)	
SIZE CODE IDENT NO. DRAWING NO. C 27327 SK58932	SCALE 1/1 WT SHEET 2
DRAFTSMAN: J.P.F. CHECK: J.P.F. PROJ. ENGR: J.P.F. RELIABILITY: J.P.F. CONTRACT NO.:	TOLERANCES UNLESS NOTED OTHERWISE: X .0005 XX .0010 XXX .0015 90° FORMED ANGLES ±.2° FINISH - SEE NOTE MATERIAL:
SUPPLY: _____ FINISH: _____ MATERIAL: _____	NEXT ASST: _____ USED ON: _____ APPLICATION: _____

FOR NOTES - SEE SHEET 3

Figure 1-2. Mod 7A Visor Blank - Sk58932-2

SECTION II
SUMMARY

This program was to provide a parabolic visor suitable for the Mark I, Model I IHMS/D System. To accomplish this, Honeywell had to select an appropriate material, develop a process, and evaluate the optical quality of the resulting product. The best material was acrylic sheet, specifically Rohm & Haas Co's Plexiglas, Type G, neutral gray, #2074.

Compression-molding and vacuum-forming processes produce satisfactory visors. Both systems require a very carefully fabricated male mold, but the compression system also requires a companion mold, thus requiring higher costs and a longer lead time. Another drawback was that cleanliness would be very difficult to handle properly in the compression molding environment. Thus, the compression molding process was abandoned in favor of the vacuum-forming method of fabrication.

The visors produced during the program varied in quality as the development progressed. Those fabricated near the end of the program for the Mark I, Mod I (Model 7A) IHMS/D systems met the bulk of the characteristics defined on the visor drawings (Figures 1-1, 1-2, 1-3).

The development showed that satisfactory visors could be fabricated by vacuum-forming techniques, when all of the below criteria are satisfied:

- Molds fabricated to the proper shape with a surface regularity of 1/2 wave or better in the critical area
- Cleanliness scrupulously maintained during all phases of assembly, forming and annealing

- Material properly dried under vacuum just before forming
- Plastic sheet pre-machined to the appropriate configuration to maintain the desired wall thickness of the finished unit
- Forming accomplished carefully and only after the mold and sheet have stabilized at the forming temperature of $325 \pm 5^{\circ}\text{F}$
- Visor blank annealed slowly to relieve stresses while still on the mold
- Visor blank removed from the mold so as not to damage the critical surfaces of the visor or the mold

The visor-forming process (see Appendix A) developed during this program satisfies these criteria.

A special test fixture was developed to evaluate the visor's optical quality. This fixture tested the visor in the same double bounce mode to be encountered in the helmet application. A photograph is taken of a resolving power test target which has passed through the optical system. The resolution capability of the visor is determined by comparing the photo to a standard. The visors produced for deliverable 7A helmets were capable of resolving 17 seconds of arc, which is considered satisfactory for the 7A systems.

SECTION III TECHNICAL DISCUSSION

Successful fabrication of this visor may be broken down into five areas of development:

- Fabrication process study
- Visor evaluation
- Mold
- Material and process
- Visor shaping

FABRICATION PROCESS STUDY

From the very first, it was apparent that fabricating this new visor by individually machining each part was not practical. Thus, a study was initiated to evaluate the various processes, and materials capable of producing a visor with the desired characteristics.

The first undertaking was to select the best material(s). Since the primary requirement was ability to "see through" the visor, only high-transmittance materials were considered. The primary candidates and their associated properties are listed in Table 3-I.

Evaluating the materials entailed judging them on the following characteristics:

- Optical characteristics
- Strength (flexural & impact)

Table 3-1. Candidate Visor Material

Property	Material						
	Acrylic	Styrene	Styrene-Nitrile (san)	Acrylic-Styrene	Poly-Carbonate	Polymethyl Pentane (TPX)	Allyl Diglycol Carbonate (CR39)
Transmittance (%)	92	88-92	80-88	90-92	80-90	>90	90-92
Index of Refraction (N _D)	1.49	1.59	1.57	1.53	1.586	1.465	1.450
Haze (%)	<2	3	<4	<3	<3	<5	
Effect of Sunlight	N. 1	Yellows Slightly	Yellows Slightly	Yellows Slightly	Discolors Slightly	Crazes Rapidly	Yellows very Slightly
IZOD Impact Strength (ft.-lb/in.)	0.3-0.5	0.35	0.35-0.5	0.3-0.5	12-17	0.8	0.2-0.4
Hardness, Rockwell	M97	M90	M80-90	M90-97	M-70	M67-74	M95-100
Heat Deflection Temp. (°F)	210	210	220	210	285		140-190
Fabricating Ease	Good	Excellent	Excellent	Excellent	Fair	Poor	Fair
Fabrication Method	Cast Molded	Molded	Molded	Molded	Molded	Molded	Cast
Flexural - Yield (1,000 psi) - Ultimate	15	10	14.2	12-13	13.5	- -	10

- Thermal stability
- Solvent resistance
- Abrasion resistance
- Fabrication compatibility

Evaluations, based on 10 for fully acceptable and 0 for totally unacceptable, produced an overall material comparison. In the case of solvent and abrasion resistance, none of the candidates was rated as fully acceptable. This comparison is shown in Table 3-II.

Table 3-II. Material Selection Matrix

	Acrylic	Styrene	Styrene-Acrylo-Nitrile	Acrylic Styrene	Poly-Carbonate	Allyl-Diglycol Carbonate
Optical Characteristics	10	10	10	10	10	10
Strength	5	3	5	4	10	5
Thermal Stability	7	7	8	7	10	4
Solvent Resistance	5	3	3	3	1	5
Abrasion Resistance	5	4	4	4	2	6
Fabrication Compatibility	10	7	7	7	7	3
Total	42	34	37	35	39	33

Note that the acrylics have the highest rating followed by the poly-carbonates. With additional development and upgrading of solvent and abrasion resistance, the poly-carbonate could rate higher than the acrylic for a visor material. However, at the present, the acrylics are definitely the best materials and were thus selected as the prime candidate for the visor.

The second part of the study was to select the fabrication process. The basic processes considered were:

- Injection molding
- Compression molding
- Vacuum forming
- Casting

In a manner similar to that used to evaluate material, the characteristics desired in fabricating the visor were selected:

- Good dimensional control
- Low part cost
- Low tooling cost
- Short lead time
- Absence of strain in finished part
- Tooling versatility - (able to handle various materials)

Evaluating these processes on a scale of 0 to 10 (where 10 was the desired level of performance) resulted in Table 3-III. Based upon this evaluation, the most desirable processes appeared to be compression molding and vacuum forming, with the part annealed after forming. However, casting and simple vacuum forming parts also appeared worth further consideration. Therefore,

Table 3-III. Process Selection Matrix

	Injection Molding	Compression Molding	Vacuum Forming		Casting
			As Formed	Annealed	
Dimensional Control	6	10	3	3	8
Part Cost	10	4	3	3	6
Tooling Cost	2	6	10	10	8
Lead Time	2	6	10	10	6
Absence of Strain	2	10	4	10	9
Mold Versatility	10	10	10	10	4
Total	32	46	40	46	41

Scale: 10 = optimum

1 = lowest performance

an individual process was not conclusively selected for Model 7A visor development. The only process discarded at this time was injection molding because the largest optical component successfully injection-molded to date was 4 inches in diameter, and the visor blank is 8-1/2 inches in diameter.

On the basis of this study, it appeared that acrylics provide the most desirable material, with compression molding and vacuum-forming sharing the role as the most promising process for developing the Model 7A visor.

VISOR TESTING

To properly evaluate the visors produced during this program, a new method of testing was developed. A double-bounce technique which reproduced the optical system of the IHMS/D unit was introduced. Figure 3-1 shows how the visor is used in the system.

With the double-bounce test system, a collimated image is projected upon the visor (as in the real system). This image then bounces from the visor to a central mirror and back to the visor again where it is reflected back toward a camera. The system, with a visor blank in place, is shown in Figure 3-2. For test purposes, the image projected was a standard resolving power test target (Figure 3-3). A baseline (or standard) condition was obtained when the visor was replaced with two pentagonal prisms, thus producing the best image transfer possible. A photo of this baseline image is shown in Figure 3-4.

This system was first used to compare the quality of visors produced by various fabrication techniques. A visor fabricated for Model 6 by machining and polishing was tested. The image seen from this visor (Figure 3-5) indicated a nonparabolic surface (at least in one axis). A visor vacuum-formed over a mold suitable for a single-bounce application was tested. The image produced in double bounce is shown in Figure 3-6.

3-7

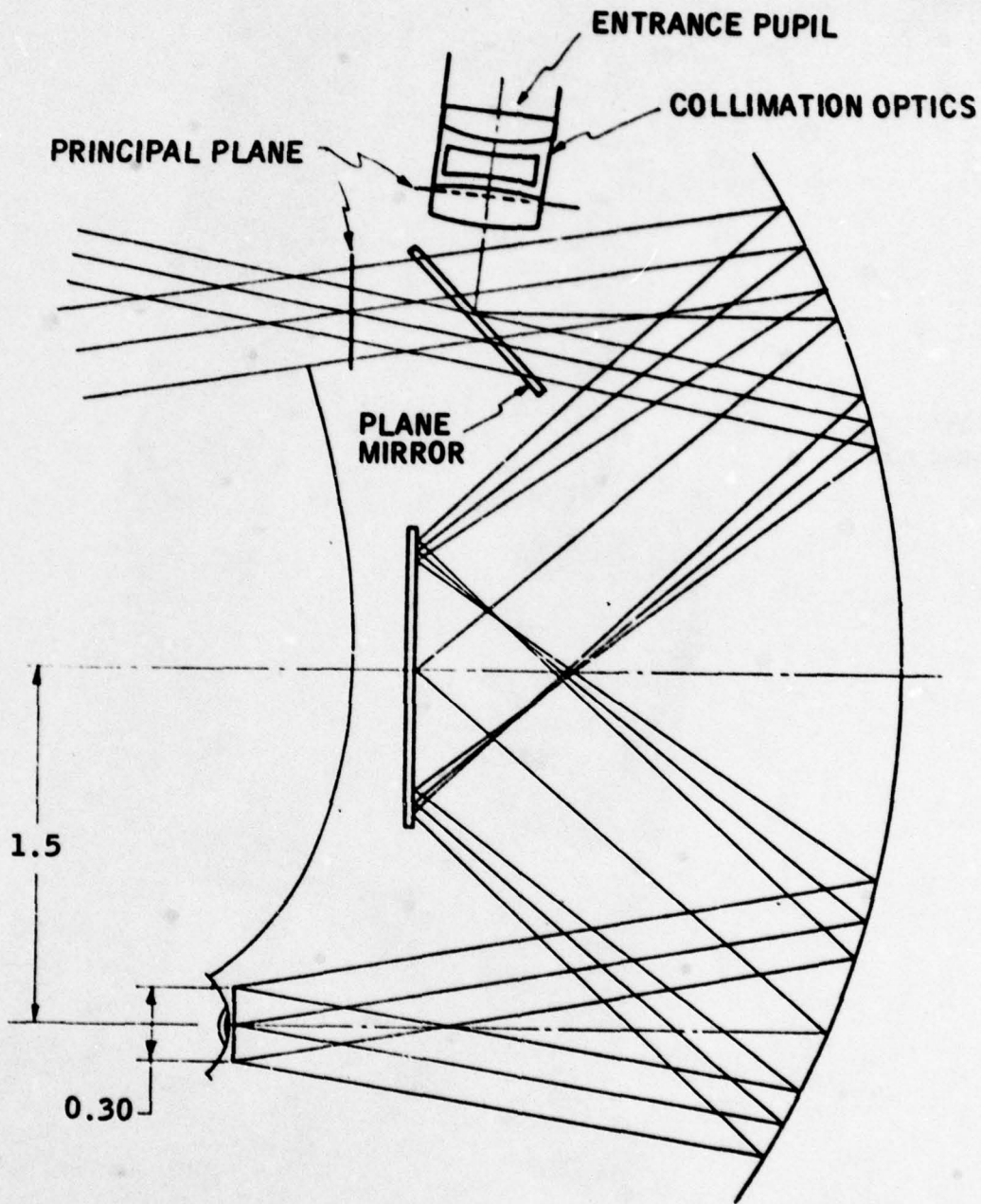

Figure 3-1. Ray Trace - Mod 7A Visor

2820-3026

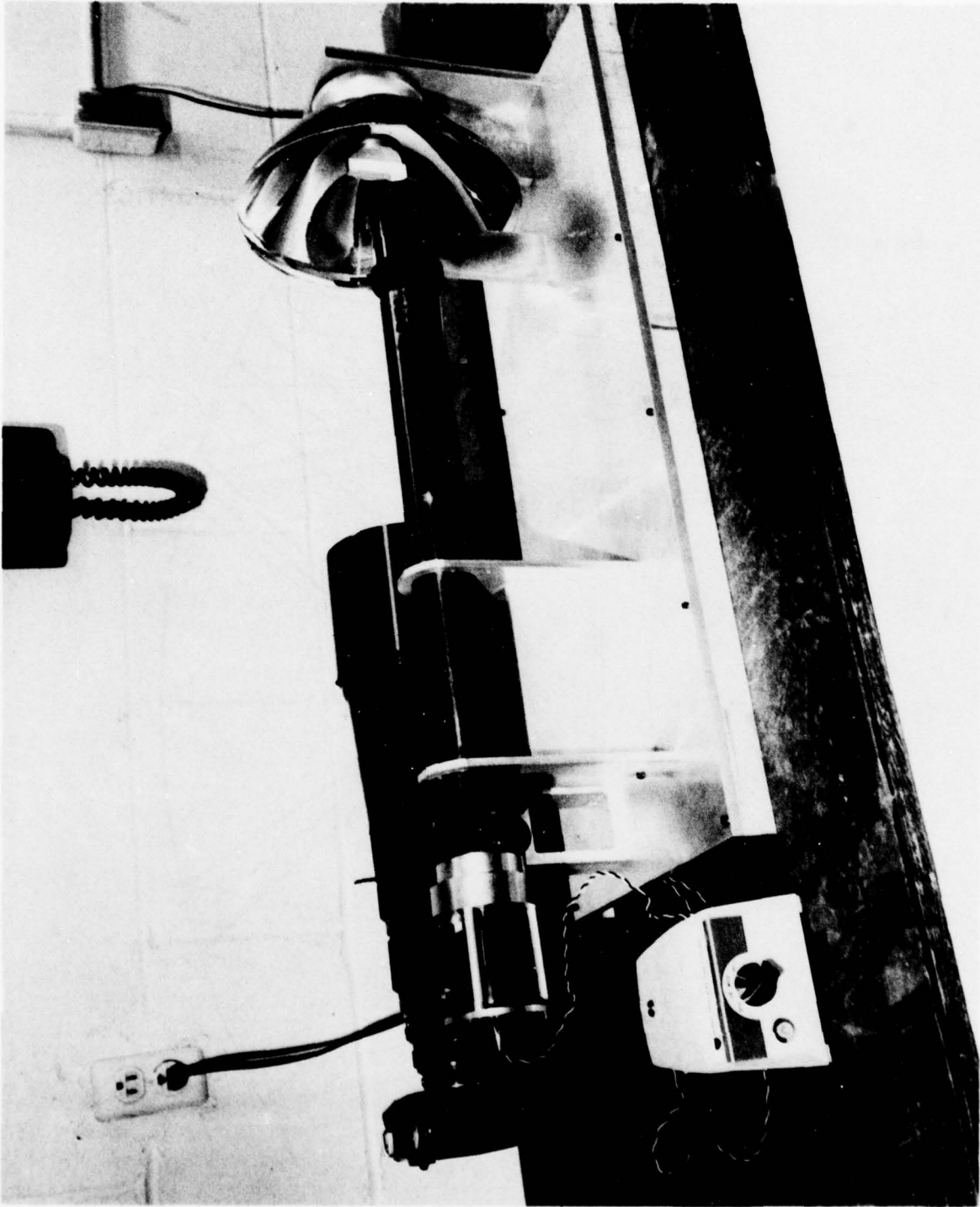

Figure 3-2. Visor Evaluation Fixture

RESOLVING POWER TEST TARGET

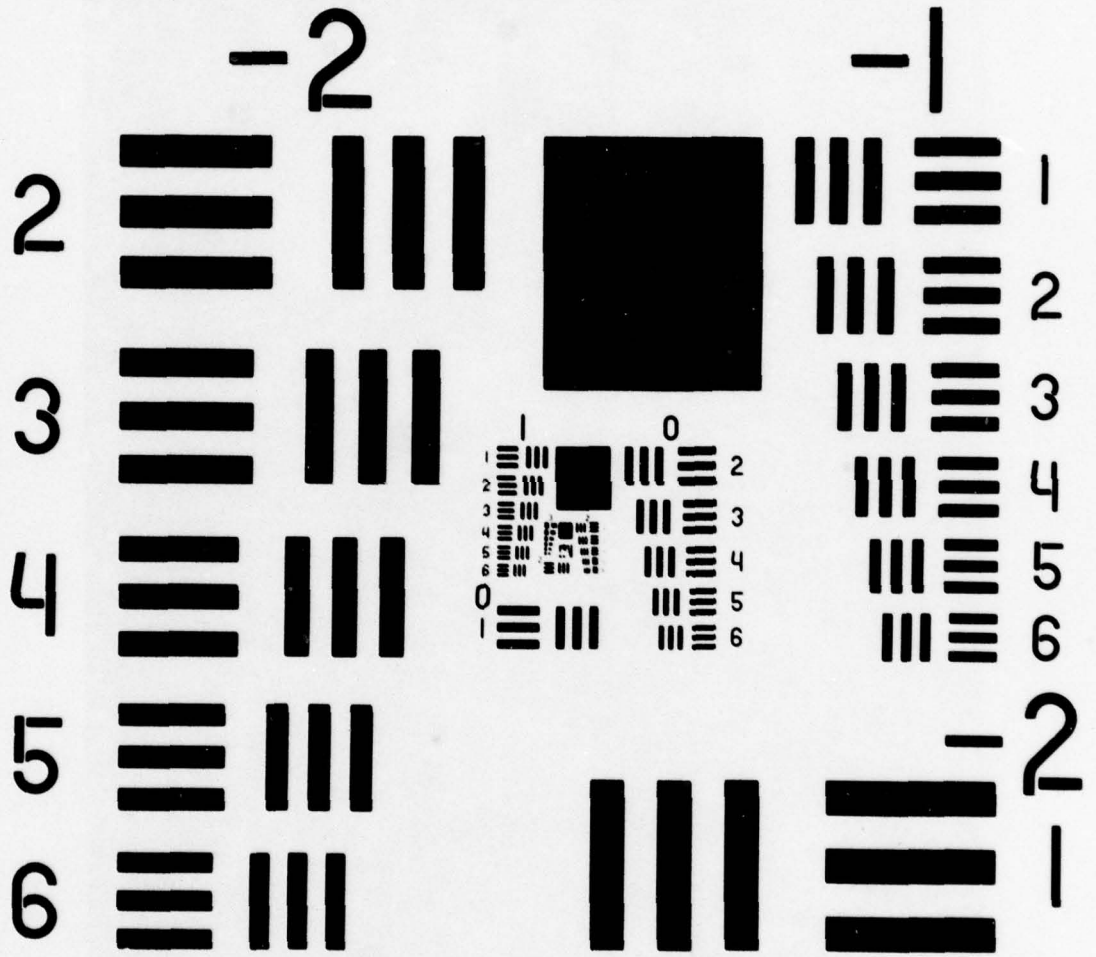

Figure 3-3. Resolving Power Test Target

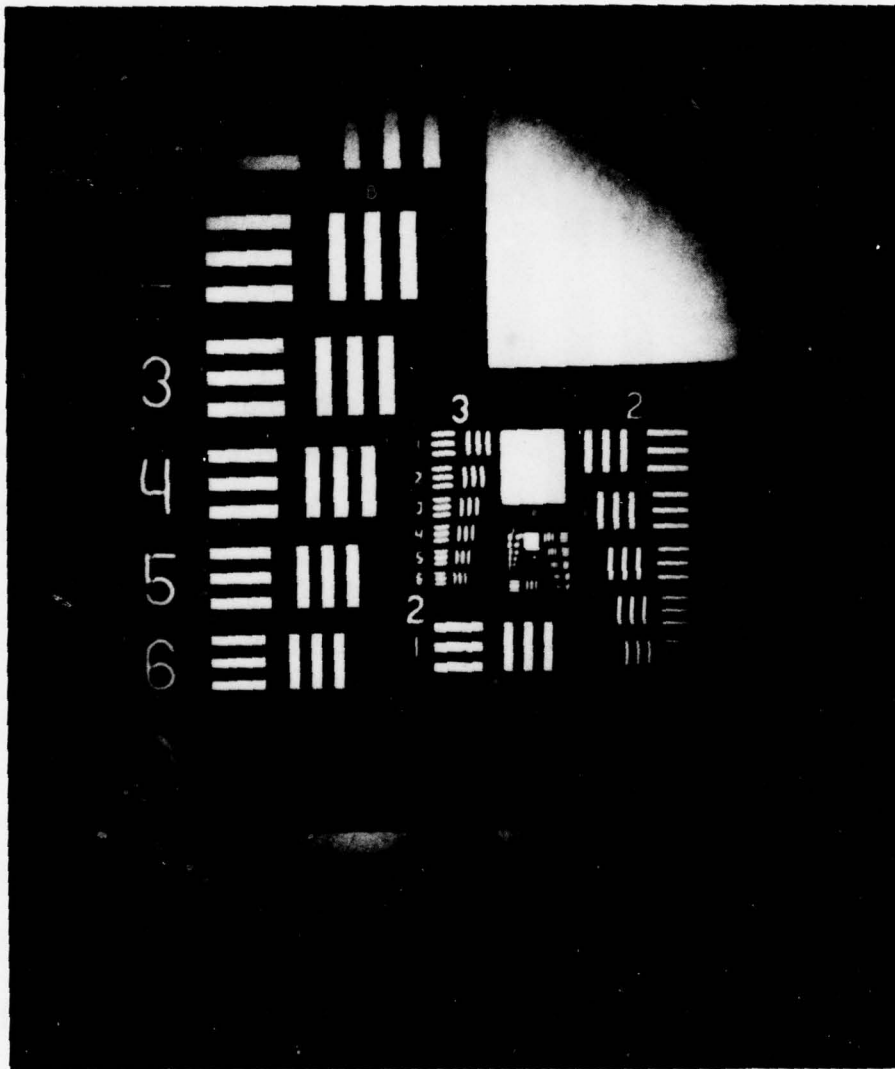

Figure 3-4. Baseline Image

3-11

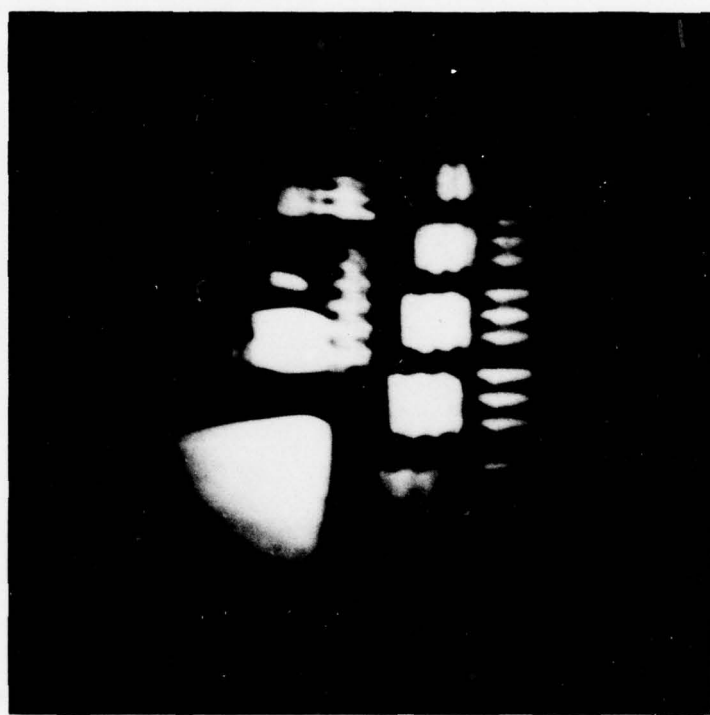

Figure 3-5. Image from Mod 6 Visor

2820-3026

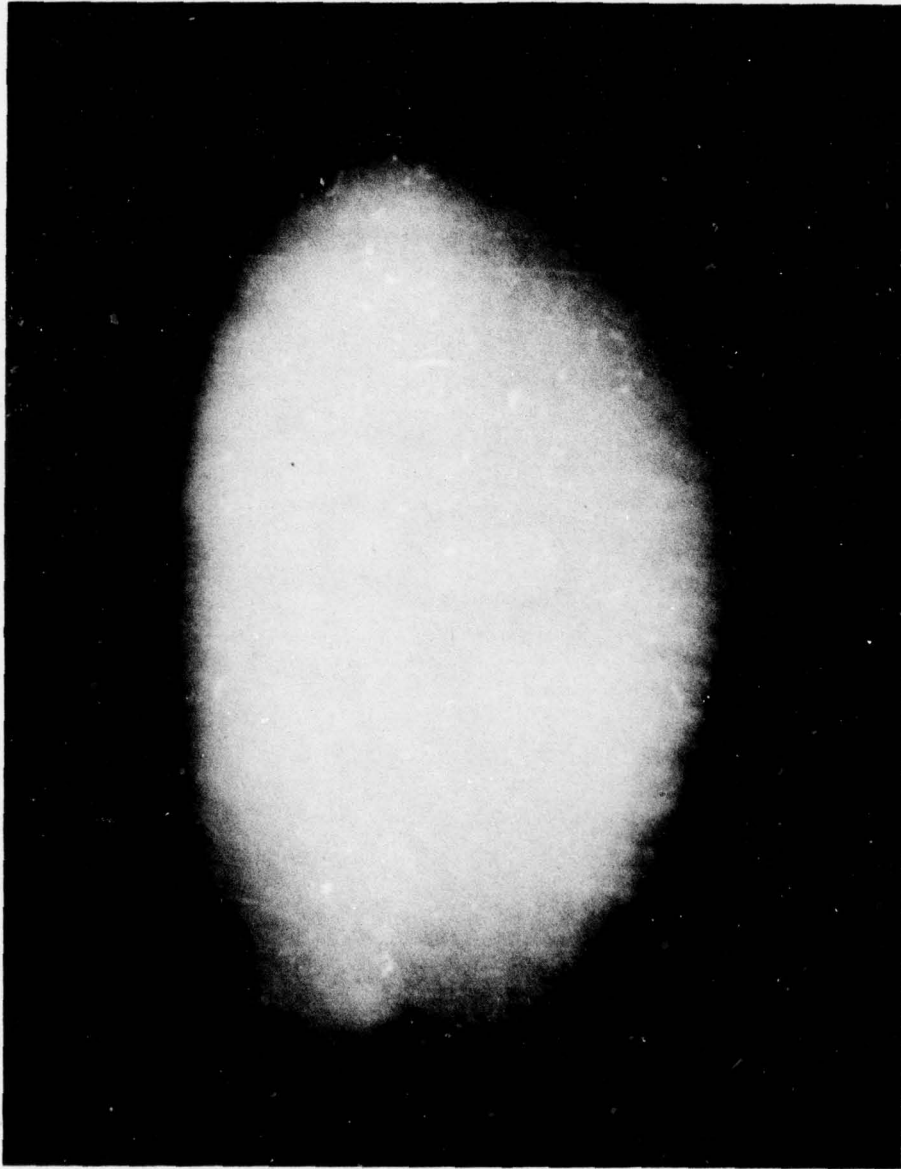

Figure 3-6. Image from Visor Blank Molded on Rough Mold

Other visor tests made during the development produced images similar to those shown in Figures 3-7 and 3-8. These figures represent visors fabricated by vacuum-forming over improved molds. The image in Figure 3-8 corresponds to a system resolution of approximately 25 lines/mm or 17 sec of arc, and is considered to be satisfactory for the IHMS/D.

MOLD DEVELOPMENT

Mold development was initiated with the 1-1/2" parabolic molds previously used to make visors for a single-bounce system. The first visors were formed on an unpolished aluminum mold. Visors formed from this mold were totally unacceptable, as indicated by the image shown in Figure 3-6. This image not only reflected the poor surface quality of the mold, but also indicated that the resulting visor was not parabolic in shape.

This mold was reworked by the Hoeger Optical Company of Chicago to produce the desired parabolic surface. Since the aluminum would not produce the desired surface finish and hardness, the mold was nickel plated before final polishing. This improved the mold greatly. The mold was now a 1-1/2" parabolic surface to within 0.0001 inch, with a surface regularity of about 0.000010 to 0.000020 of an inch (1/2 to 1 wavelength) over a 1 square inch surface. This unit was capable of producing good visor blanks. The double bounce image from one of these blanks is illustrated in Figure 3-8.

During the development effort, some problems were encountered with the aluminum mold, the major problem being a noticeable deterioration of the parabolic surface due to high temperature cycling. Measurements were taken on this mold midway through the development, which indicated a significant shift in the mold contour. Apparently, the material had not been properly heat treated and, thus, was shifting during the high temperature cycling necessary to form a visor. The contour curves (shown in Figure 3-9) do not

3-14

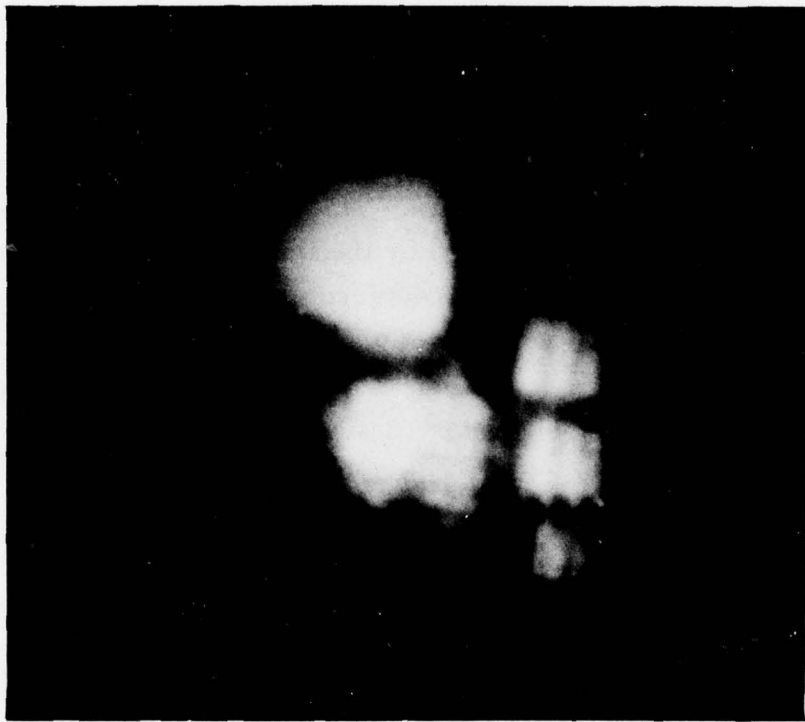

Figure 3-7. Image from Visor Blank Molded on Polished Mold

2820-3026

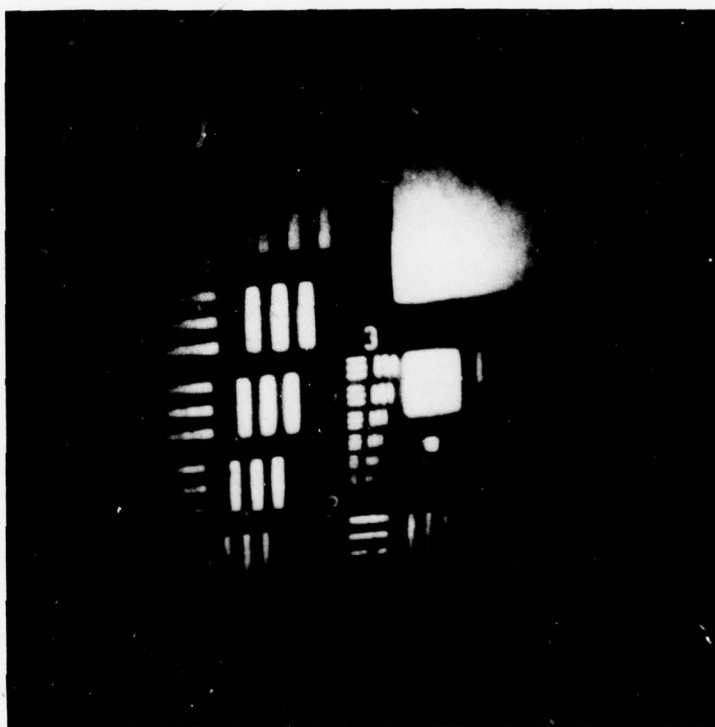

Figure 3-8. Image from Best Visor Blank Molded on Polished Mold

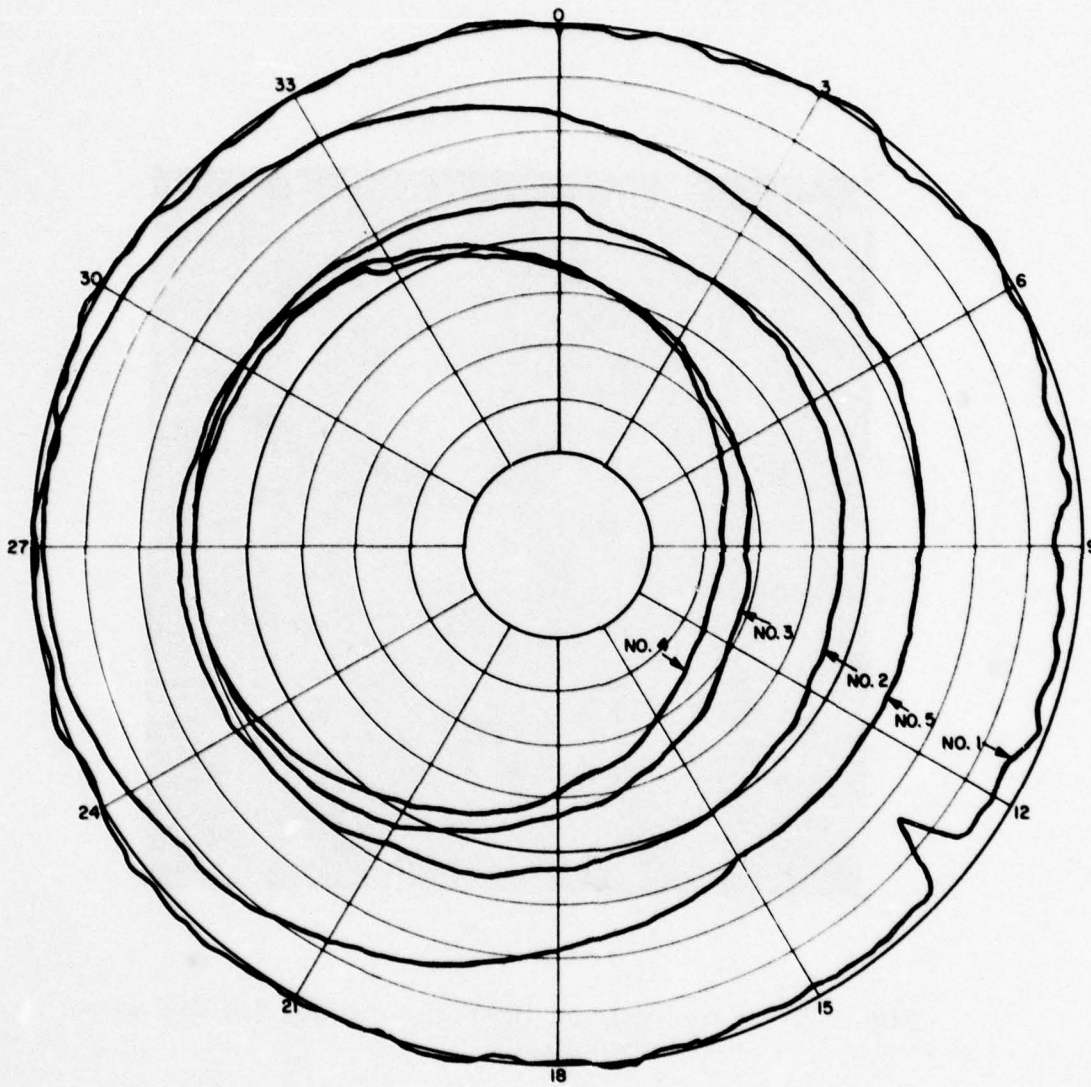
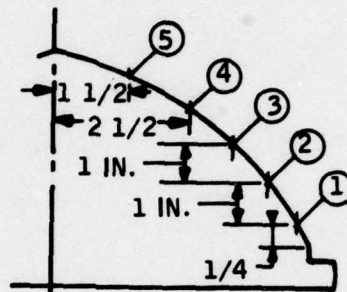

Figure 3-9. Indiron Data - 1-1/2-inch Mold

reflect a significant change in surface regularity, but do show a shift in concentricity at various levels on the mold. The five rings shown below represent data taken at five levels of the mold.



The scale for curve #1 is 0.0001 inch/division, while the others used a 0.0002 inch/division scale.

Once the desired visor configuration for Model 7A was established, the mold was ready to be fabricated. Because of the problems encountered with the aluminum mold, it was agreed that the new mold should be made of steel. Also, since the vacuum-forming process had produced good visors during the developmental work, it was decided to fabricate a single male mold. On the basis of dimensional stability, cost, and availability, an air-hardenable tool-steel was selected for the mold. The desired surface quality and corrosion resistance were obtained by applying an electroless nickel plating over the critical surface. This mold is shown in Figure 3-10.

The mold was rough-cut and shipped for finishing to KMS Technology Center, Aspheric Optics Systems, Irvine, California. The mold was of approximately 0.002 undersize, and returned to Honeywell for nickel plating.

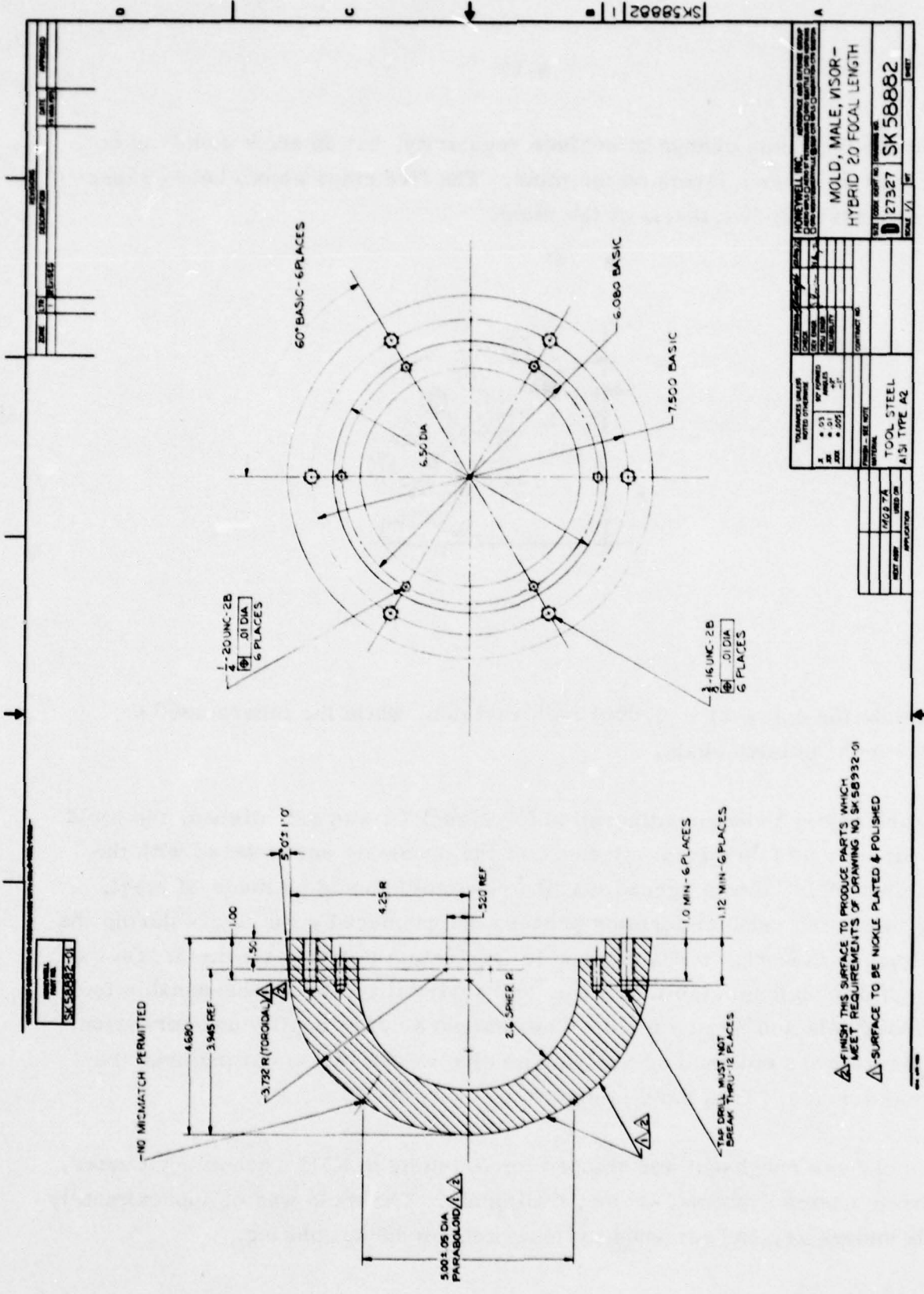

2820-3026

Figure 3-10. Mold - 2-inch Parabolic Mold

Following plating of the mold, it was returned to KMS where the final machining and polishing was completed. The mold was measured and found to be within 0.000040 inch of the desired shape over the parabolic surface, and had better than 1/2 wave (0.000010 inch) regularity over small areas of approximately 1 square inch.

When the finished mold returned to Honeywell, it was installed on a base plate which provided a flat surface perpendicular to the parabolic axis. The mold and plate assembly were then checked for roundness and axis perpendicularity. Contour curves were taken approximately at the points shown in Figure 3-11. The curves (Figure 3-12) showed the axis to be perpendicular to within 0.005 inch, and the roundness of the mold in the critical parabolic area to be within 0.0002 inch TIR.

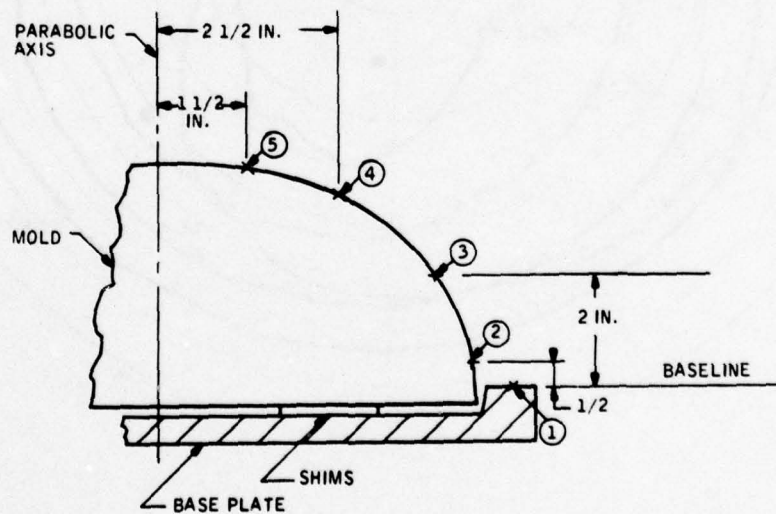

Figure 3-11. Two-inch Mold Showing Indiron Test Data Points

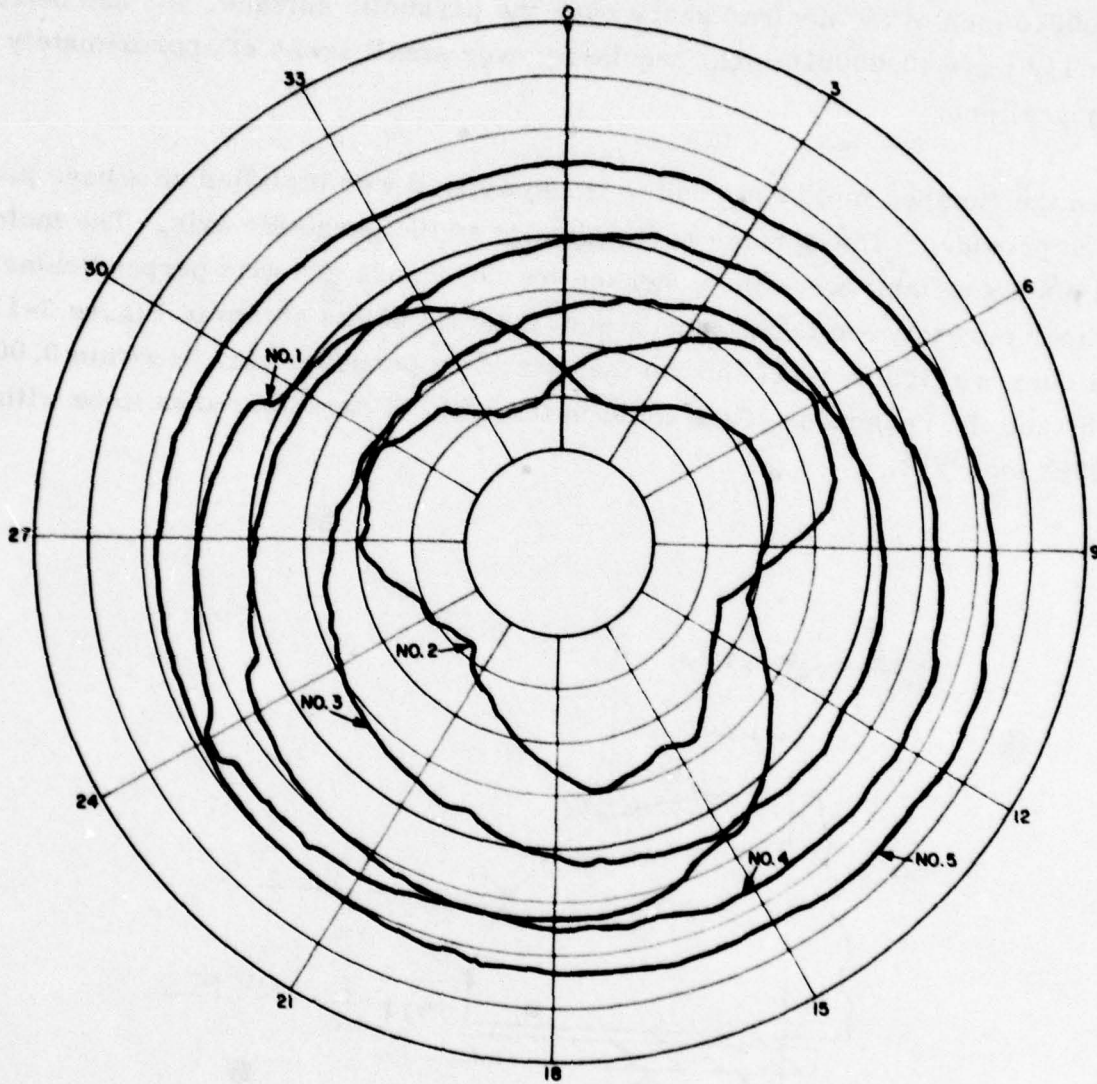

Figure 3-12. Indiron Data - Two-inch Mold

The contours taken in the critical annulus area (circles #4 and 5) generally showed surface regularity over small areas ($\approx 1''$ long) as being 0.0001 TIR or better. This means that over a length of one inch, the surface did not vary from a true circle by more than 0.0001 inch. These data generally indicated that the mold was satisfactory and that visor fabrication could begin for Model 7A. Figure 3-13 shows the image quality typically seen in the double-bounce test with these visors.

PROCESS DEVELOPMENT

During the literature search for the process study, some preliminary laboratory work was conducted to aid in selecting a process. Several 1-1/2-inch focal length parabolic molds from previous visor programs were used. Two methods of fabrication, casting and vacuum forming, were tried with these molds during the first stage of development.

Several visor blanks were made by a vacuum process called "drape" forming. Acrylic sheets were heated and formed over an aluminum male mold on a standard vacuum forming machine where the mold was moved into the plastic sheet and final forming of plastic was completed with vacuum. These units were found to be unsatisfactory as the reflective surface contained concentric waves.

Next, a male and female set of molds were used to cast several visor blanks. Both molds were aluminum and had been machined to a basic 1-1/2-inch parabola. Samples were cast using 1) CR-39 polymer; 2) Hysol-TC9-6175; and 3) Marglas. In each case, the cast surface replicated that of the mold. The surface appeared to be frosted, producing the mat finish of the molds. Furthermore, removing the blank from the mold was a problem. Mold-release agents helped, but tended to impregnate the plastic material during the curing cycle.

3-22

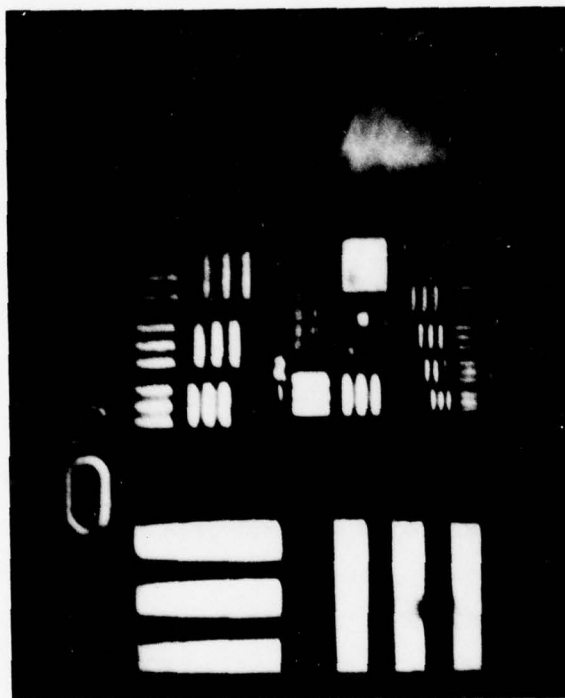

Figure 3-13. Image from Two-inch Mold

2820-3026

When the visors, both cast and drape-formed, were aluminized and tested for reflection characteristics, the cast visors would not reflect an image at all. The vacuum (drape)-formed units were smooth and did reflect, but the image quality was poor, probably because of a poor parabolic surface. To improve the parabolic shape, the mold was nickel plated and sent out for regrinding.

The Fabrication Process Study discussed later was completed about the same time the reworked mold was returned. Both the study and the results of previous casting trials argued for discontinuing casting to prevent mold damage. Therefore, when the mold arrived back at Honeywell, it had already been decided that compression molding and vacuum forming were to be the prime candidates for further study.

Vacuum Forming: 1-1/2-inch Mold

The reworked mold was found to have an excellent surface finish (very highly polished) and appeared to be a good parabola. While tooling was being designed and fabricated for compression molding, the mold was used to continue evaluation of the vacuum forming process. Several visor blanks were fabricated at our plastic laboratory by vacuum forming (drape forming method). The best unit obtained during this stage of the program was formed, cooled and removed from the mold in the shortest possible time (approximately 10 minutes). The double-bounce image from this visor is shown in Figure 3-8. Unfortunately, the image quality shown was not uniformly distributed over the complete visor. The photo represents the best area and, thus, further demonstrates that the mold is indeed a good parabola. While the drape-formed visors had small areas better than anything previously made, they were unsatisfactory overall. The inner surfaces of the visors were marred by three significant defects:

- Dirt
- "Orange peel"
- Irregularities due to trapped air bubbles

Two paths were selected which could improve the situation. The first was compression molding of the vacuum-formed blank in order to eliminate the orange peel and surface irregularities. The second approach was to switch to an improved vacuum/thermal forming technique, which would eliminate the unwanted dirt and air.

Compression Molding: 1-1/2-inch Mold

The polished male (1-1/2-inch parabolic) mold was installed in a compression molding press with an unpolished female mold. To evaluate the fabrication process, only the inner (or concave) surface was required to produce optical quality as we were interested primarily in the visor's double-bounce characteristics.

Four visor blanks were successfully fabricated by the compression molding process. These were made with acrylic preforms which had been vacuum formed and then cut to the proper size. The preforms were placed in the mold which had been preheated to approximately 350°F. The molds were brought together with a force exerting 600 psi pressure on the plastic preform. The temperature and pressure were maintained for 30 minutes. The unit was then slowly cooled to 150°F while the pressure was maintained. This process produced an acceptable unit. Optically tested in the double-bounce system, the visor tested out as well as the best vacuum formed unit (see image illustrated by Figure 3-8). The visor produced this way was also determined to be free of thermal stresses.

Although the inner surface was basically good, matching that of the mold, the outer surface reproduced the mat surface quality of the female mold and thus prevented see-through testing. The inner surface still showed evidence of surface flaws and imperfections (primarily from dirt), which reaffirmed the need for a clean process. Compression molding produced the same visor optical quality as vacuum forming. Since two molds are required versus one for vacuum forming, compression molding was considered to be too complex and costly, and the decision was made to concentrate on vacuum-forming investigations.

Improved Vacuum Forming

As mentioned above, the first vacuum-formed visors were rejected because of dirt, gas (air) pockets and "orange peel." A system analysis determined the causes of each of these problems.

Dirt particles in the visors resulted from the vacuum forms being located in an open shop area. The plastic produced a strong static electrical attraction for the dust of dirt particles in the air. Thus, it was apparent that a very clean environment was required. A completely closed chamber capable of supporting a vacuum was selected as a potentially clean environment. The vacuum chamber would also reduce or eliminate the problem of gas bubbles in the visor.

The "orange peel" distortion of the visor surface was traced to interaction between the hot plastic sheet and the cold metal mold. It was eliminated by simply having the mold and plastic sheet at the same temperature during forming.

Experimental forming in a clean, high-vacuum environment was carried out in a large space chamber. The mold and plastic sheet were held by a fixture

which allowed them to be heated to the same temperature. Both sides of the plastic sheet were in the vacuum environment throughout the process of drying, heating, and forming. The actual forming process was carried out by increasing the pressure on the outside of the visor rather than by drawing a higher vacuum on the inside.

This double-vacuum system (Figure 3-14) was set up and samples made for evaluation. A sheet of plastic (acrylic) was blow-molded into the preformed hemisphere, which cleared the mold as shown. (Note that the vacuum between the plastic sheet and the mold can be controlled by a valve such that this volume can be interconnected to the oven chamber or isolated and evacuated separately.) During the drying and heating cycles, the two volumes are interconnected (valve open) to the main vacuum pumps, thus maintaining a uniform vacuum on both sides of the plastic sheet. When the desired temperature is attained for the forming operation, the valve is closed and a vacuum is maintained between the plastic and the mold while the chamber pressure is increased slowly to standard atmospheric pressure. The differential pressure across the preform forms the plastic to the mold. Figure 3-15 shows the system installed in a space chamber. The shield has been dropped to reveal the molded visor blank still on the mold.

The first visor blank was formed at a temperature of $+270^{\circ}\text{F}$, which was the capacity of the heaters. This unit was unsatisfactory as it contained areas of severe distortion. Larger heaters were obtained and a second unit formed at a plastic temperature of 330°F . The distortion was eliminated; however, this visor had a number of spots on the critical surface which were thought to be caused by oil from the vacuum pumps.

Cold traps were installed in the vacuum line, but still the spots remained. Closer monitoring of the process revealed that at 250°F the preformed bubble began to relax into its original flat form. As the material sagged, it touched the mold prematurely. At 250°F , the material had not softened sufficiently

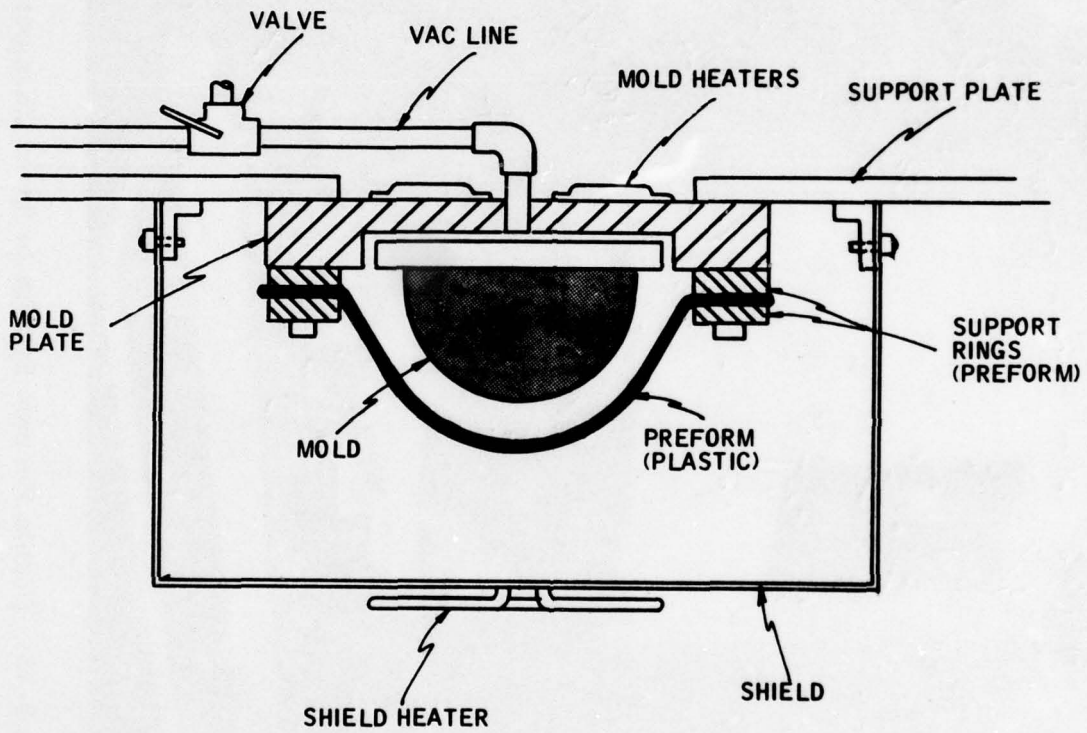

Figure 3-14. Double-Vacuum Fabrication System

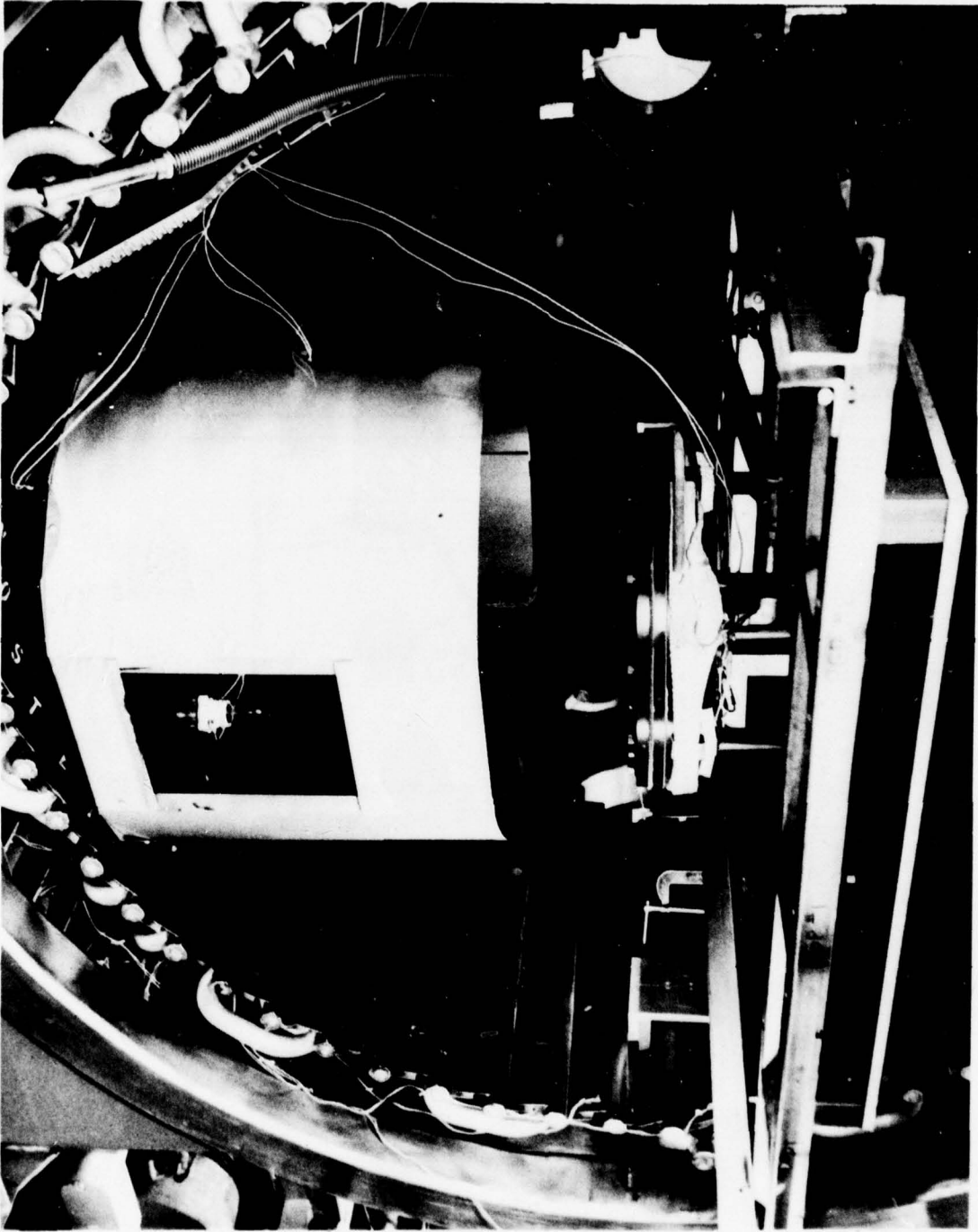

Figure 3-15. Double Vacuum System in Space Chamber

for proper forming, and the surface quality was destroyed. Minimum material temperature for forming appeared to be 290°F.

As a result of these tests, it was determined for the best results, we would have to work with a flat sheet of material. This necessitated another tooling redesign. Keeping in mind the problems previously encountered, we fabricated the closed system shown in Figure 3-16. Since this fixture was a sealed unit which could support the desired vacuum levels, an ordinary oven could be used in place of the bulky space chamber. This figure shows the system as assembled with the flat sheet and as formed with the sheet drawn down over the fixture body and mold. Figure 3-17 is a photograph of a fixture without plastic sheet and cover.

The process as first attempted was as follows:

- 1) Fixture and plastic sheet assembled in clean room
- 2) Fixture installed in large oven
- 3) Vacuum applied to both sides of plastic and oven set at 200°F over night
- 4) Oven turned up to 350°F for three hours
- 5) Plastic sheet formed when temperature of plastic sheet reads 330 to 335°F
- 6) Fixture cooled and part removed

The first visor so fabricated looked good: no evidence of trapped air bubbles and an excellent surface finish. The double bounce test revealed a good image (≈ 25 lines/mm) in small areas. However, there was a ring of distortion noticeable in see-through evaluation. It was determined that this ring was caused by the plastic sagging and touching the mold during the heating cycle. During forming, the remaining material is pulled over the mold, causing a

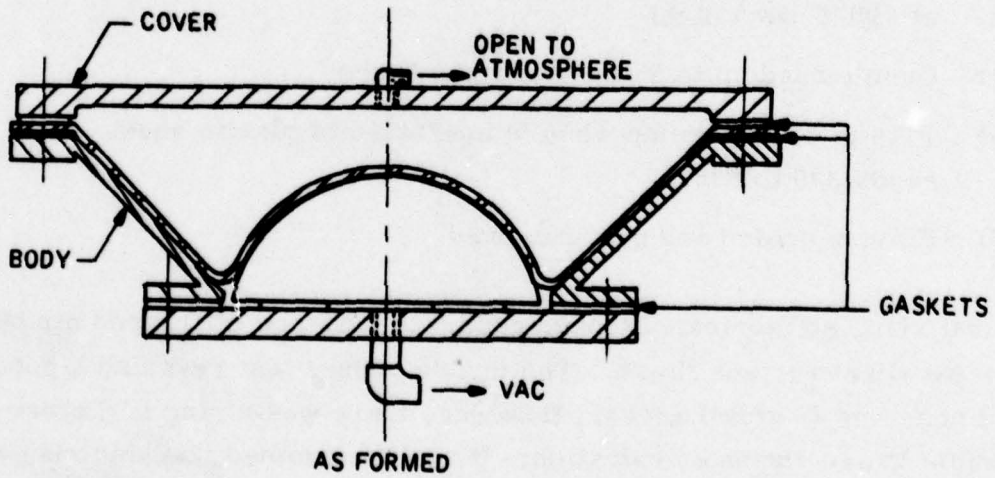
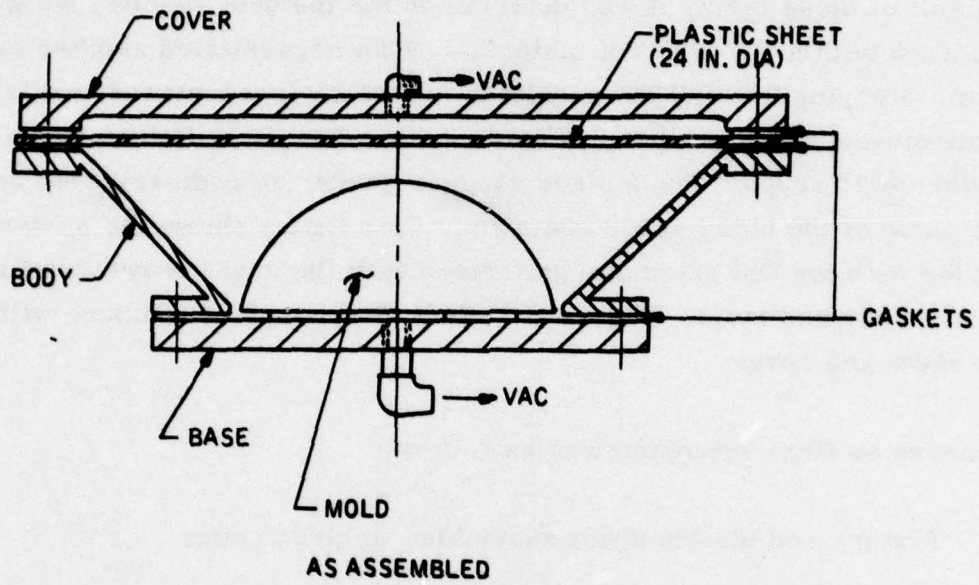

Figure 3-16 Closed Vacuum Forming System

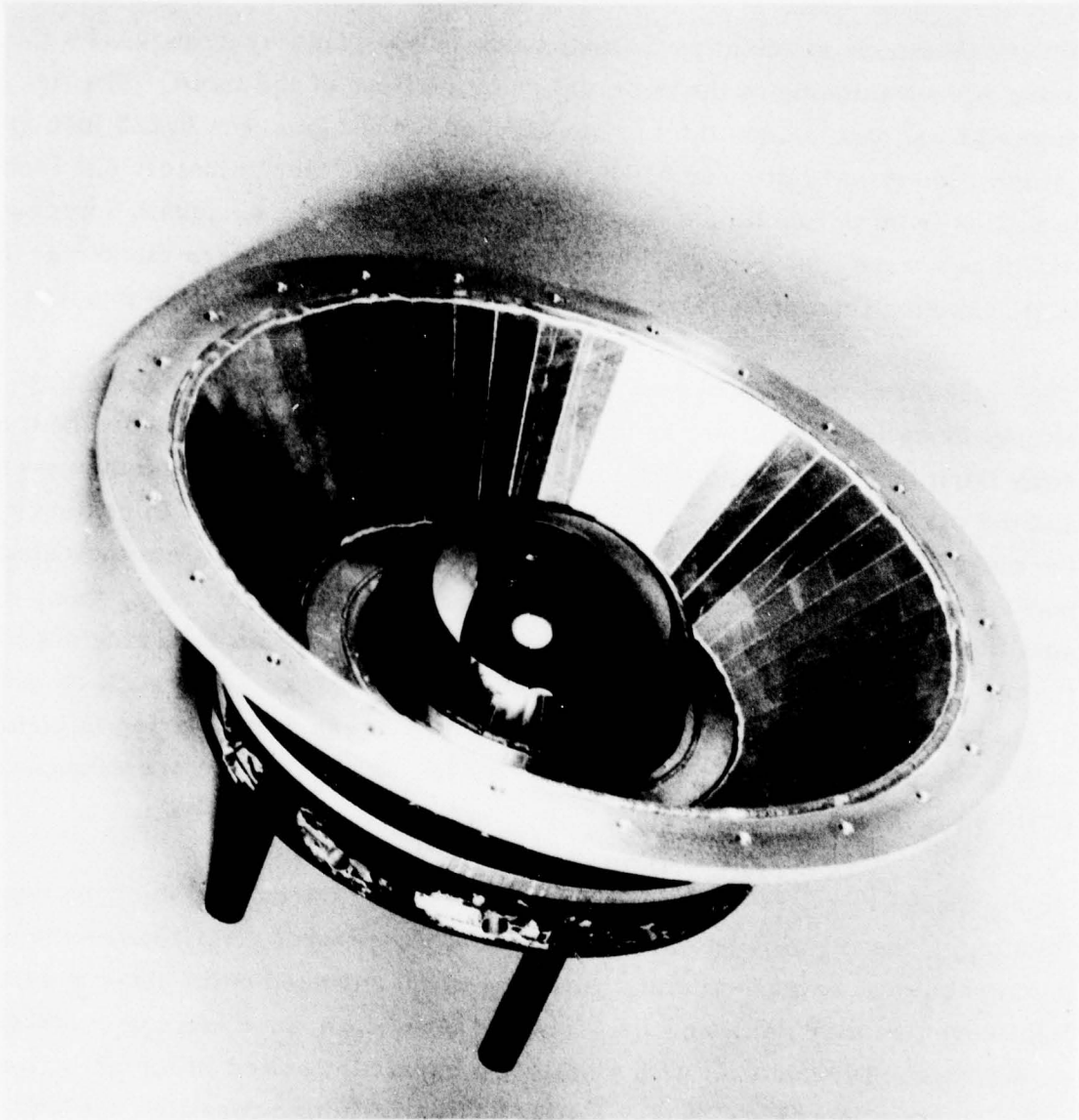

Figure 3-17. Vacuum Forming Fixture Base with Mold

severe thickness gradient at the transition point. This system results in a more severe thinning of the material near the base of the mold. The flat sheet material was 0.125-inch thick. The formed visor blank was 0.123 inch at the center, and thinned down to 0.055 inch at the edge (approximately 4.5 inches in radius from parabolic axis). Visors made by previous vacuum-forming techniques were also generally 0.123 inch at center, but were thicker at the edge, ranging from 0.085 inch to 0.120 inch, depending upon the process.

The problem of the ring of see-through distortion was easily resolved by simply inverting the fixture in the oven so that, during heating, the sheet sags away from the mold. Additional clearance was provided between the cover and the plastic sheet to assure that the plastic would not come in contact with the cover. The first attempt at forming a visor with this system indicated that the sag was too much to be accommodated with a spacer ring, thus, a smaller stop ring was installed as part of the cover. This stop ring supported the plastic sheet during heating, and contacted the plastic on a surface outside of the usable area, thus preventing the critical areas from coming in contact with other portions of the cover during the heating cycle. This configuration is illustrated in Figure 3-18.

This process resulted in good quality visors, with the exception of the edge thinning. The thinning became a problem when several visor blanks cracked during removal from the mold. Analysis of the cracked units under polarized light revealed thermal stresses. Thus, the need for an annealing cycle was established. Discussions with plastic lab experts resulted in the selection of an eight-hour anneal at 220°F. Following the forming operation, the unit was maintained in the oven at 220°F for the full eight-hour period with the vacuum retained on the mold side of the sheet. Following this anneal, the normal cooling cycle was completed and the visor blank removed from the mold without incident. Polarized light tests now revealed a unit free of stress lines. The process for forming a good visor blank using the 1-1/2-inch parabolic mold is summarized in the forming cycle defined in Figure 3-19.

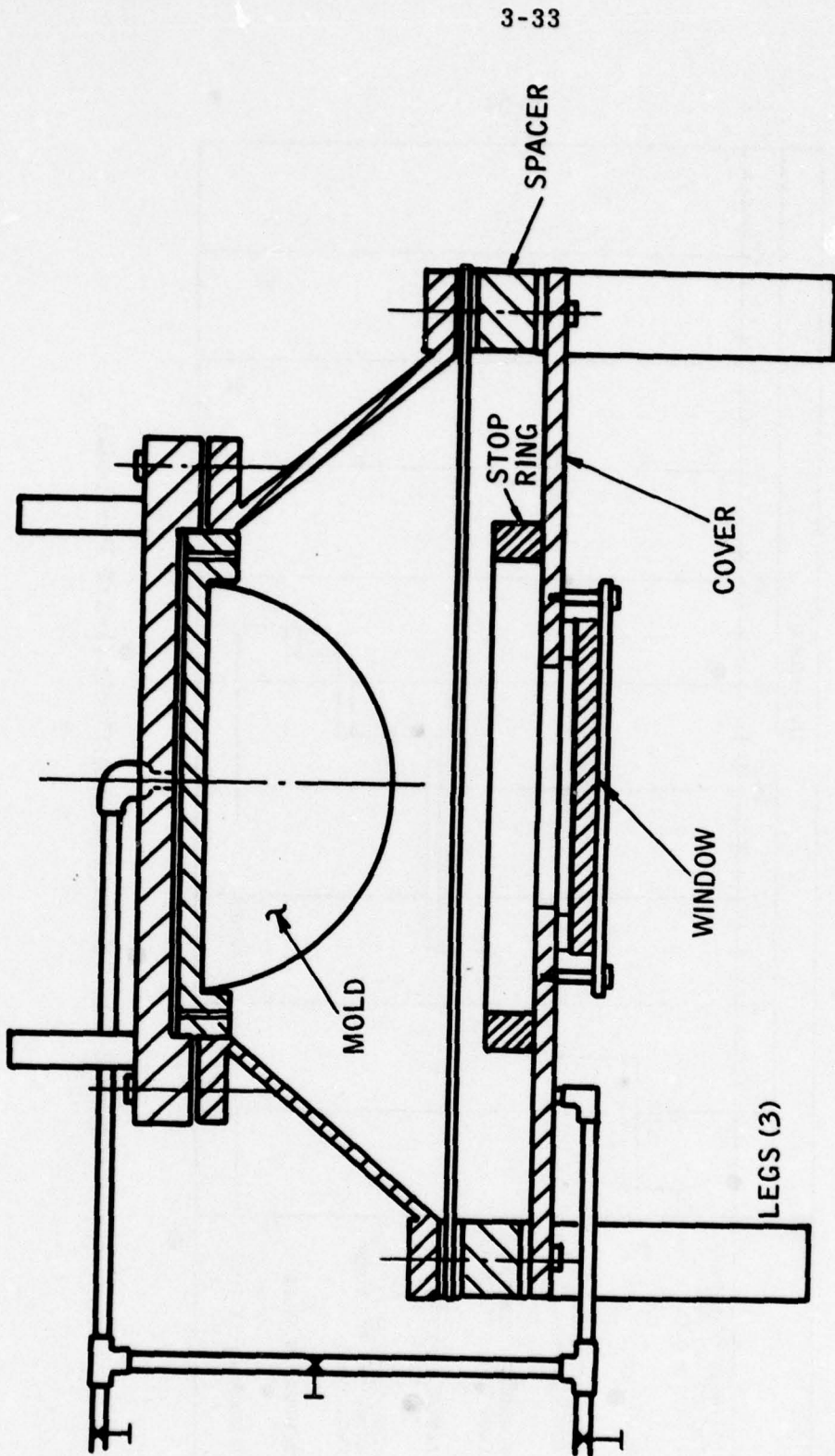

Figure 3-18. Inverted Mold Configuration

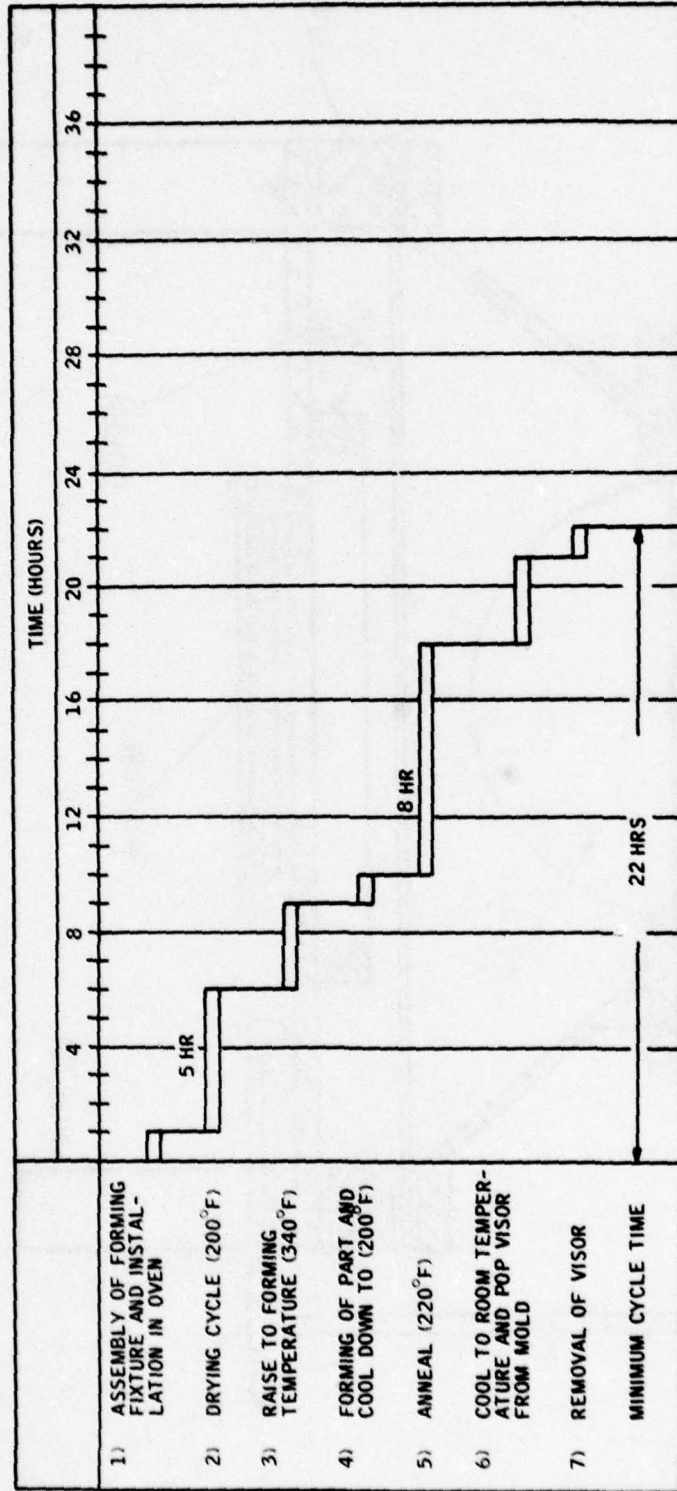

Figure 3-19. Visor Forming Cycle (1-1/2 Parabola)

Development with 2-inch Mold

The new 2-inch mold was mounted in the fabrication fixture and a visor blank formed. The resulting visor formed nicely, but difficulty was encountered in removing the visor blank from the mold. The blank cracked in the process, and thus was not usable for optical testing. A check of the blank revealed the material had thinned from 0.125 at the parabolic axis to 0.042 at the edge of the mold. This thinning out had been noticed earlier during the molding with the 1-1/2-inch mold.

A comparison of these two molds (1-1/2-inch to 2-inch, Figure 3-20) revealed the reason for both the increased thinning of the material and the difficulty in removing the blank from the mold. The 2-inch mold (hybrid) had a much steeper draft over the lower portion of the mold. A comparison of visors

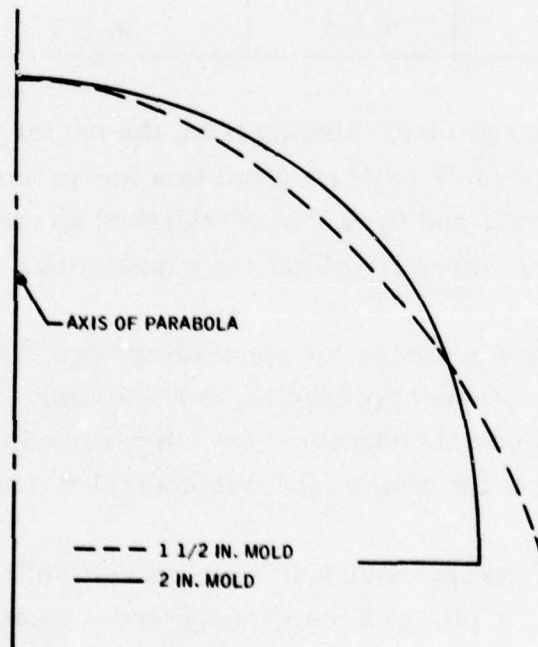

Figure 3-20 Comparison of Mold Shapes

molded by different techniques shows a variation in thickness. The original "drape"-forming technique produced the most uniform wall thickness, ranging from 0.125 inch at apex to 0.081 inch at the edge near the base of the mold. The closed (most recently developed) system produced a similar thickness at the center, but reduced the edge thickness significantly, as shown in Table 3-IV.

Table 3-IV. Summary of Visor Thinning Data

Process	Mold	Flat Sheet Thickness	Material Thickness	
			at center of blank	at edge of blank
Drape forming (open system)	1-1/2"	0.125	0.125	0.081
Closed system	1-1/2"	0.125	0.123	0.060
Closed system	2"	0.125	0.123	0.042

Analysis indicated that gradual thinning from the center to the edge of the visor surface was desirable as it resulted in a low prismatic deviation. However, there was a limit, and 0.60 was established as the minimum thickness required for structural integrity of the visor mounting.

A number of alternative methods for controlling edge thinning was studied. The most promising options appeared to be 1) building a new fixture which would move the mold into the plastic sheet, thus reducing the depth of the draw, and 2) modifying the plastic sheet to control thinning.

The plastic modification approach was considered first because it could be quickly investigated. A plot was made of the cross-sectional area of a visor blank (Figure 3-21). This plot showed the effect of the deep draw upon material thickness. (Note that the thinning is not uniform: the plastic over the mold thins out more than the plastic over the conical frame. The reason for this can readily be seen when one looks at the cross-sectional area of concentric cylinders moving from the mold axis outward to the edge of the mold.)

3-37

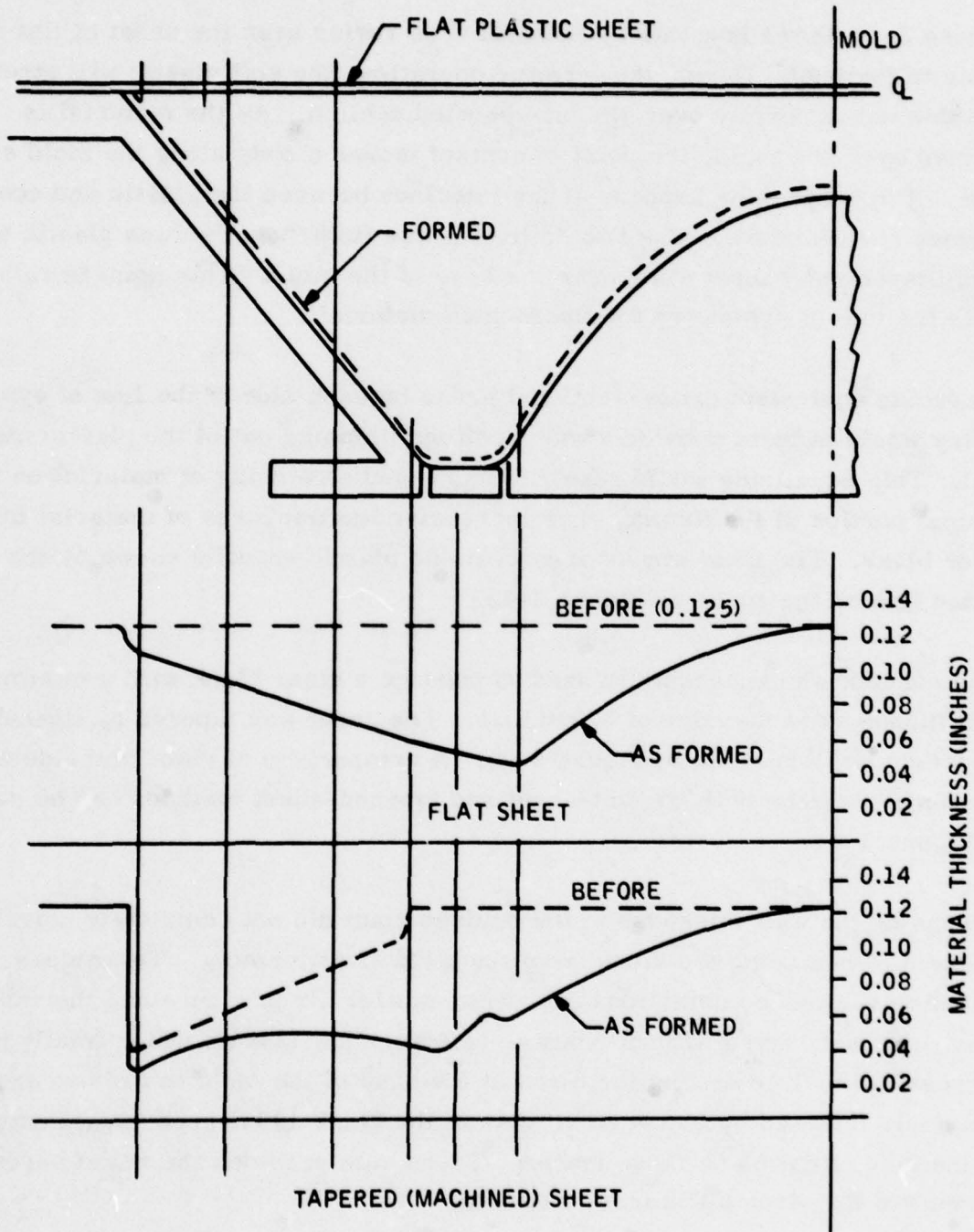

Figure 3-21. Change in Plastic Sheet During Forming

2820-3026

Figure 3-22 shows how this cylindrical area varies over the sheet of flat plastic prior to forming. During the forming operation, the soft plastic will stretch and thin out uniformly over the unsupported section. As the material is formed over the mold, the point of contact moves slowly along the mold surface. The same thing happens at the interface between the plastic and conical surface of the fixture. The two critical areas (interface between plastic and metal) eventually meet at or near the base of the mold. This point is referred to as the line of symmetry for the formed material.

Producing equivalent cross-sectional areas on each side of the line of symmetry would at least provide a more uniform thinning out of the plastic material. This equalizing would result in increased stretching of material on the conical portion of the fixture, thus increasing the thickness of material in the visor blank. The ideal stress area over the plastic sheet is shown by the dotted line on the curve of Figure 3-22.

This concept was successfully used to produce a visor blank with a minimum wall thickness at the edge of 0.060 inch. The sheet was tapered by fly-cutting a surface as illustrated in Figure 3-23. A comparison of visor and side wall thickness made by both the flat-sheet and tapered-sheet methods can be seen in Figure 3-24.

Increasing the wall thickness to the desired point did not completely solve the problem of removing the blank from the mold after forming. Techniques including various combinations of vacuum and/or air pressure and thermal conditions were tried without positive results. The system which finally proved successful involved cutting the blank at the base of the mold to remove excess material, followed by two vertical cuts in the blank 180 degrees apart extending up the side of the blank three inches. These cuts provided the relief necessary to remove the visor blank from the mold.

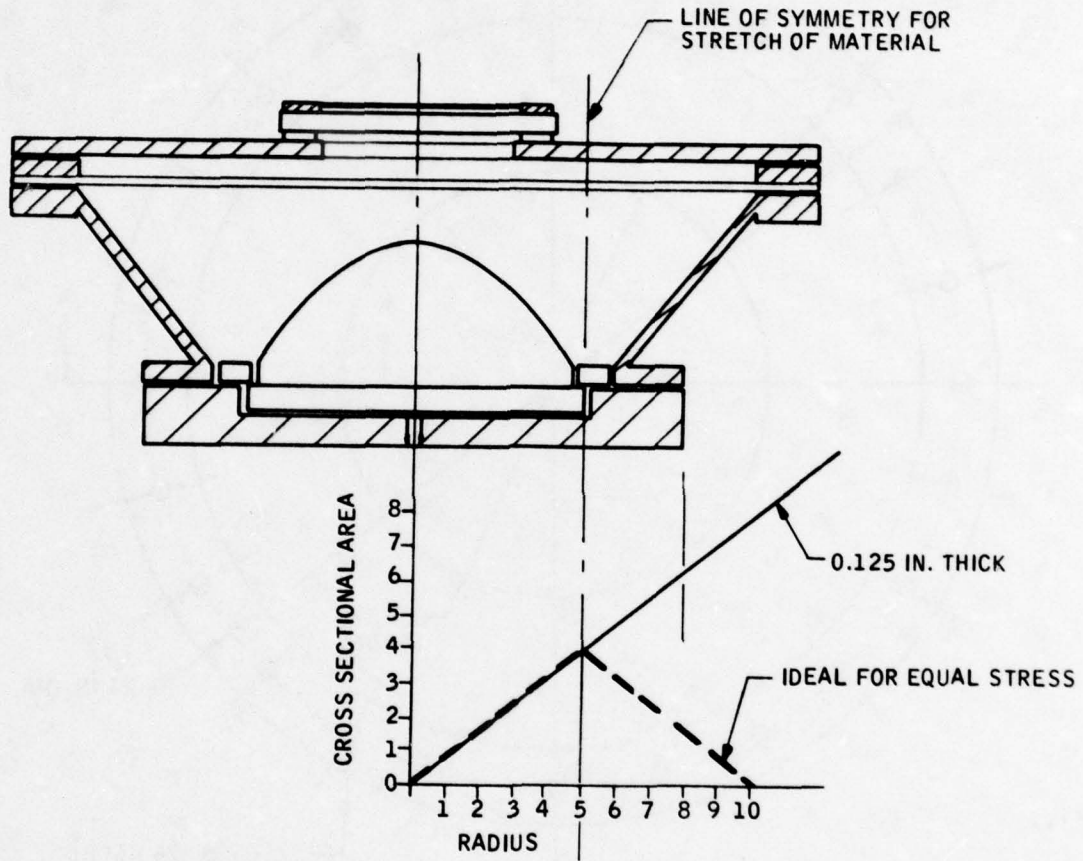

Figure 3-22. Cross-Sectional Area Considerations

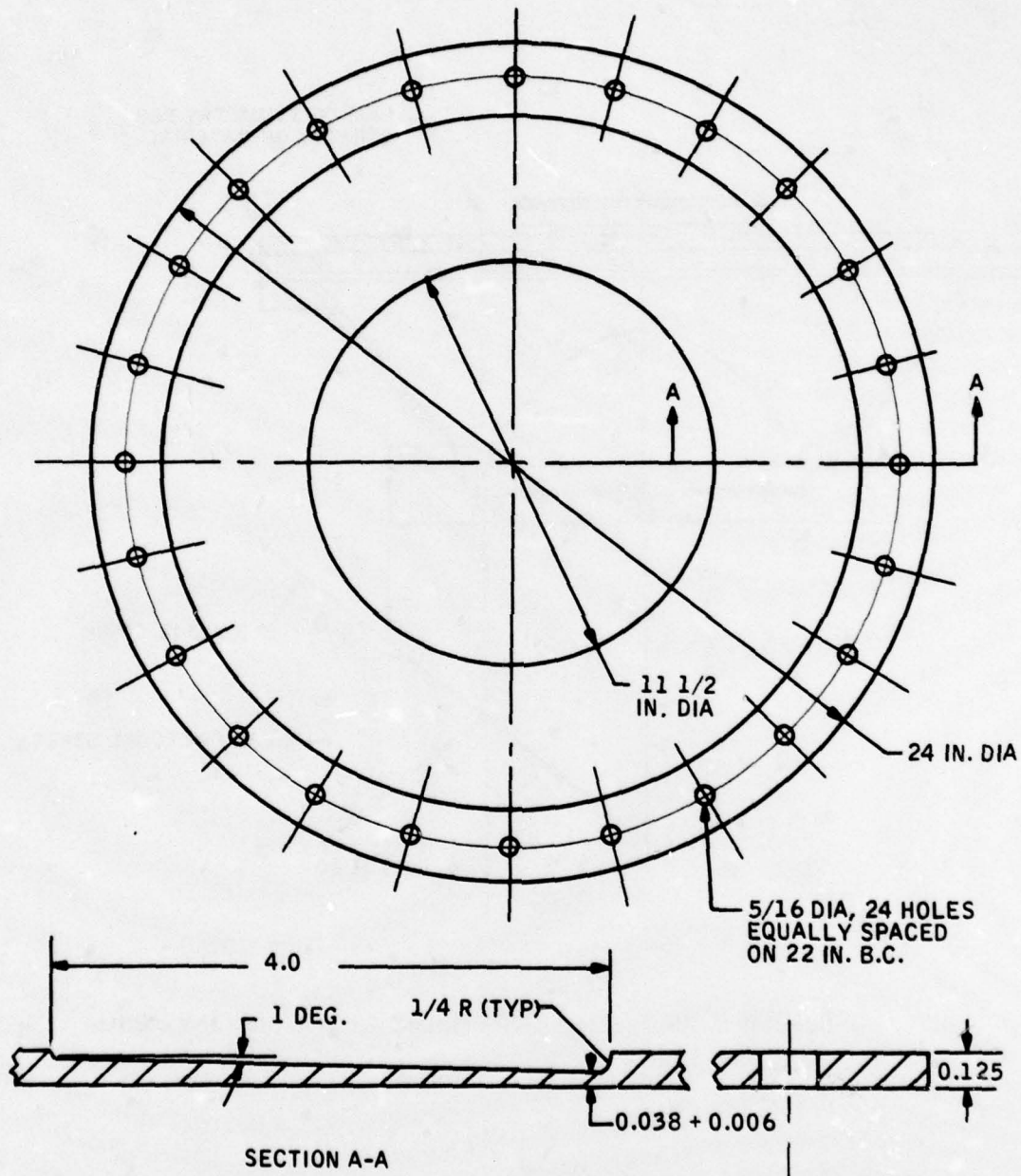

Figure 3-23. Plastic Sheet - Machining for 7A Visor Fab

3-41

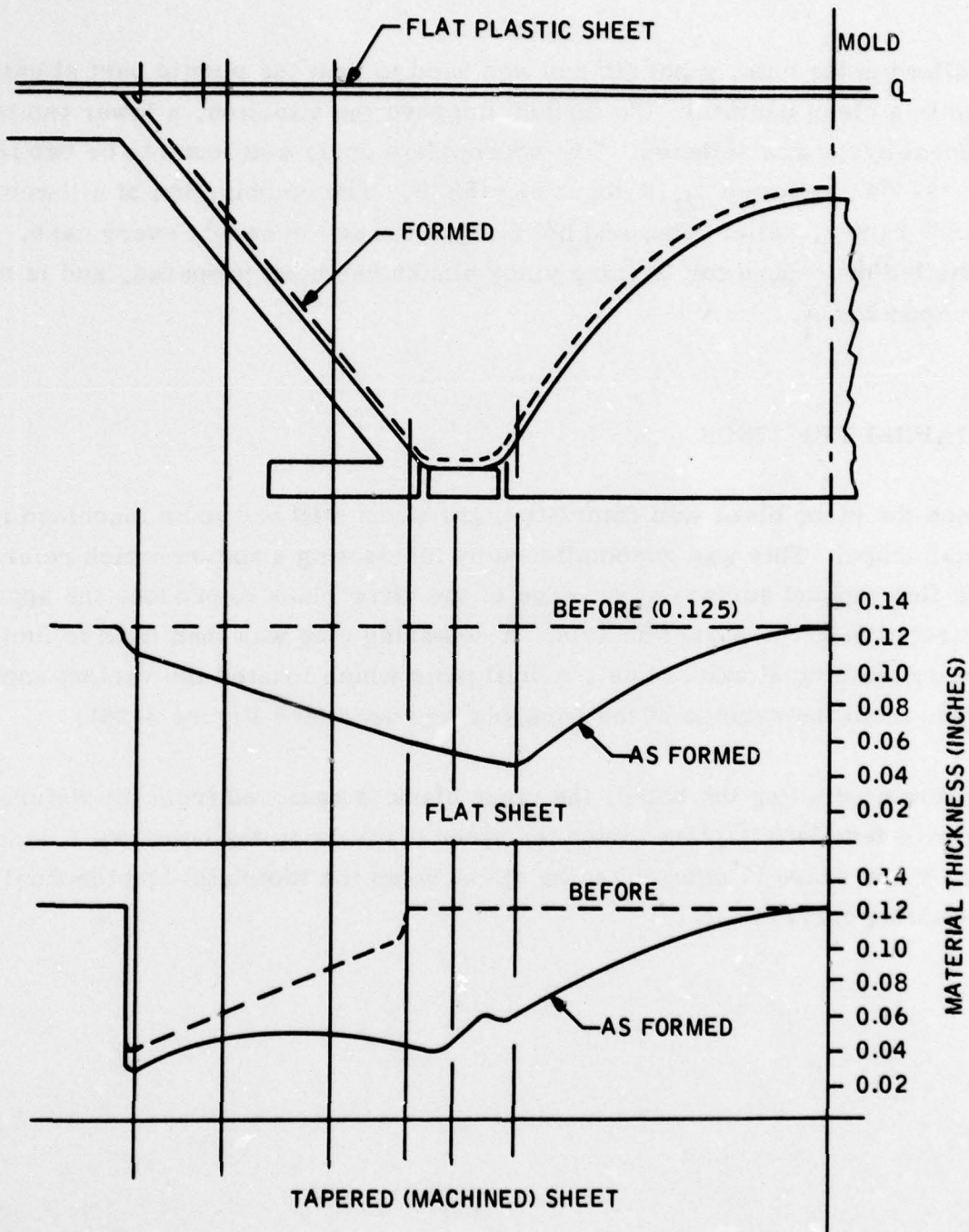

Figure 3-24. Sheet Thinning Comparison

Following the cuts, a hot air gun was used to heat the plastic part slightly to aid in a clean removal. To further improve the situation, a lower temperature anneal cycle was selected. The appropriate cycle was found to be two hours at +220°F, followed by 16 hours at +165°F. The combination of a lower anneal temperature, relief cuts, and hot air gun worked in nearly every case. A detailed procedure for forming visor blanks has been prepared, and is included in Appendix A.

SHAPING THE VISOR

Once the visor blank was completed, the visor still had to be machined into final shape. This was accomplished by fabricating a fixture which referenced the flat-molded surface at the edge of the visor blank to produce the appropriate orientation of the parabolic axis. A centering ring was then used to further locate the optical axis. Last, a drill plate which located the various mounting holes from the surface of the parabola was used (see Figure 3-25).

Following drilling the holes, the visor blank is removed from the fixture. Now, a template is placed over the visor blank using the holes for orientation. The visor shape is marked on the visor (from the template) and the final trimming carried out.

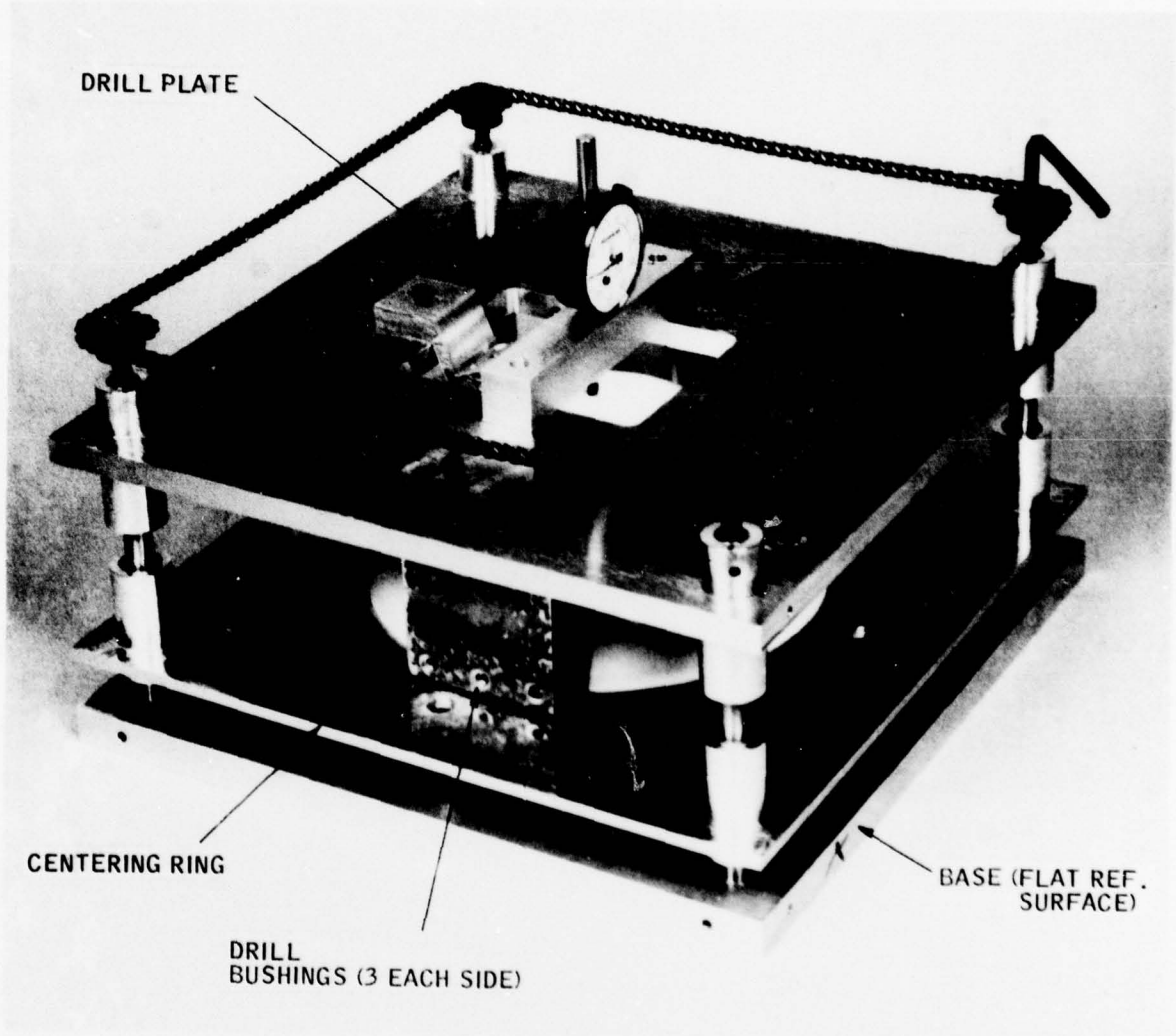

Figure 3-25. Visor Cut-out/Drill Fixture



APPENDIX A
DETAILED OPERATING PROCEDURE FOR
VISOR BLANK FORMING

This appendix describes the technique developed by Honeywell for fabricating SK58932 parabolic visors for the LG1083AA01 IHMS/D. This device has also been designated as the Mark I, Model I (Model 7A) IHMS/D by the U.S. Air Force.

The method used is to vacuum form a sheet of acrylic plastic, 0.125-inch thick, neutral gray (12 to 15 percent transmission) over a nickel-plated steel mold. The mold is defined by drawing SK58882. The technique employs a closed vacuum system, which provides the control necessary for producing the optical quality surfaces of the visor. Visor blank fabrication consists of three distinct phases: 1) assembly of the forming fixture; 2) the forming cycle; and 3) removal of the formed blank from the mold. Trimming of the blank into a visor is not included as part of this procedure.

ASSEMBLY OF VISOR FORMING FIXTURE

Assembly of the components into the forming fixture (Figure A1) is very important. The parts, plastic sheet, mold and fixture parts must be carefully cleaned to be free of dust and dirt. To assure maximum surface quality of the finished visor, all cleaning and assembly must be done in a clean room environment.

Before assembly starts, the plastic sheet should be machined to the configuration shown in Figure A2. When installed in the fixture, the sheet is to be oriented with the machined surface away from the mold. The fixture, including vacuum lines and valves, shall be completely assembled as shown

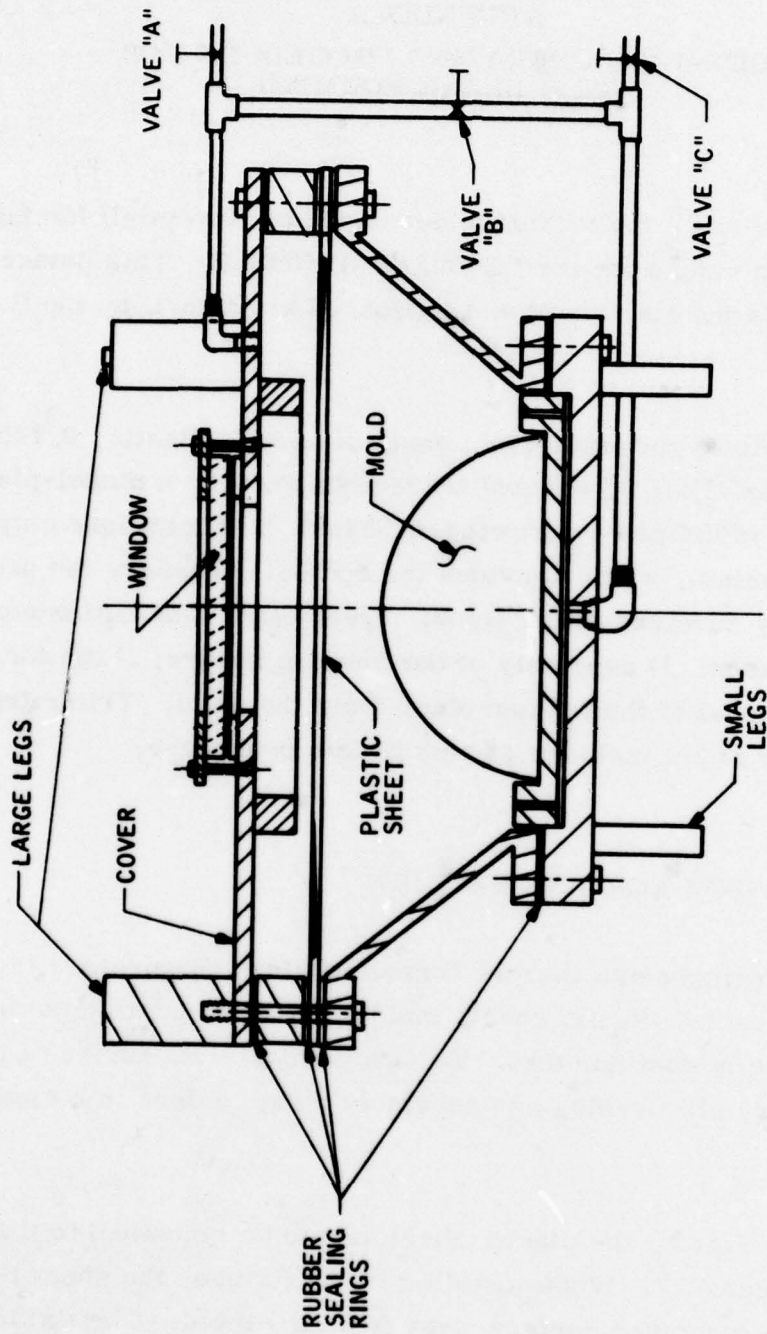

Figure A1. Visor-Forming Structure

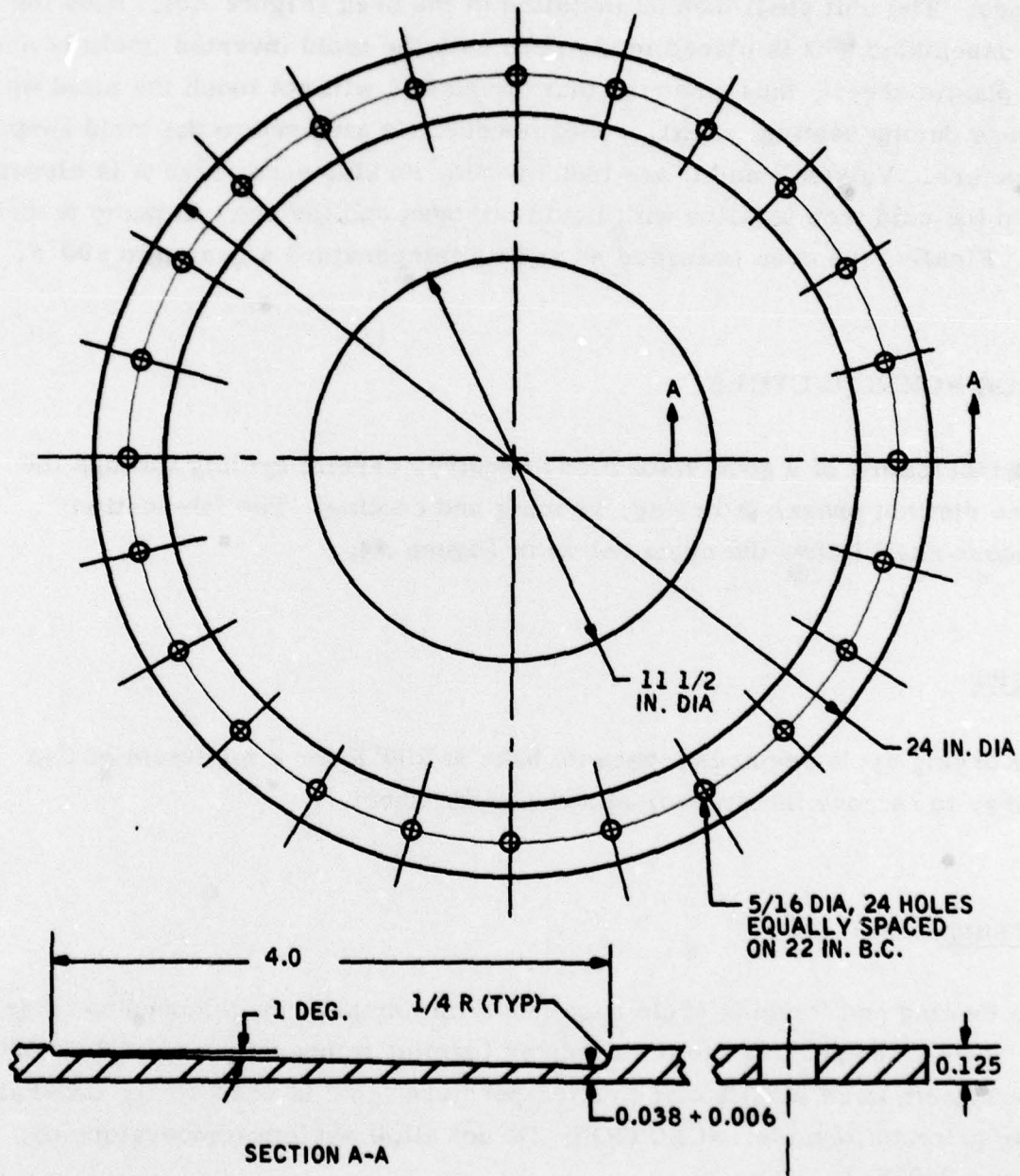

Figure A2. Plastic Sheet-Machining for 7A Visor Lab

in Figure A1 before removal from the clean room area. Valves shall be closed. The unit shall then be installed in the oven (Figure A3). Note that the assembled unit is placed in the oven with the mold inverted (mold is above the plastic sheet), thus ensuring that the plastic will not touch the mold when it sags during heating. Next, a thermocouple is attached to the mold support structure. Valves B and C are then opened, making sure valve A is closed. Then the cold trap is filled with liquid nitrogen and the vacuum pump turned on. Finally, the oven is turned on and its temperature adjusted to 200°F.

VISOR FORMING CYCLE

The fabrication of a good visor blank requires careful cycling through the three distinct phases of drying, forming and cooling. The fabrication process shall follow the cycle shown in Figure A4.

Drying

The drying cycle requires a vacuum bake at 200°F for a minimum of five hours, to remove moisture from the acrylic sheet.

Forming

The heating and forming cycle requires a minimum of three hours to raise the system temperature to the required forming temperature of +320 to 330°F. The system must stabilize at this temperature (goal is +325°F) for one-half hour prior to forming. (CAUTION: Do not allow system temperature to exceed 330°F.)

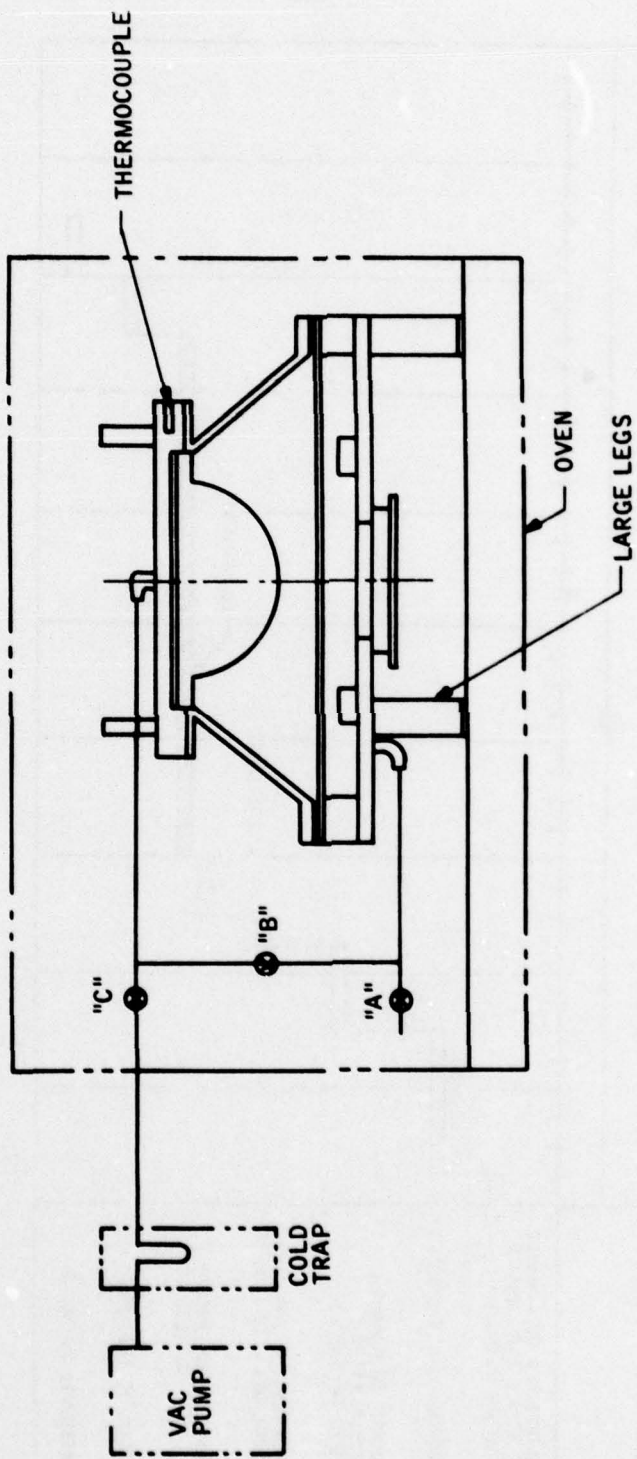
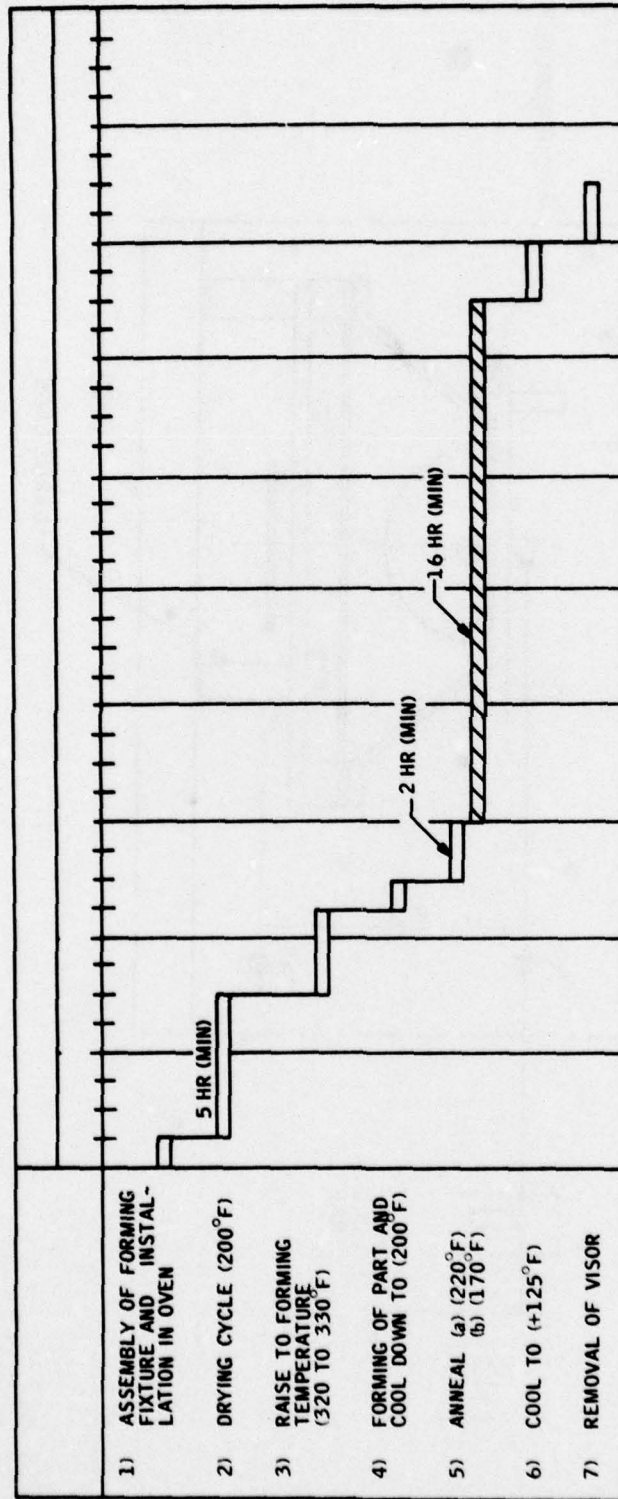

Figure A3. Visor-Forming System



2820-3026

Figure A4. Visor-Forming Cycle (2-in. Mold)

Forming is accomplished by closing valve "B" and slowly opening valve "A" (see Figure A3). This operation maintains the vacuum between the mold and the sheet while allowing the pressure on the opposite side of the sheet to increase. The differential pressure causes the sheet to pull up against the mold, forming the visor blank. The oven heaters shall be turned off during forming.

The following visual observations shall be made:

- (a) Prior to starting the forming, the plastic sheet shall be sagged to the point where it is clearly visible through the window.
- (b) As valve "A" is opened (the pressure increases), the plastic sheet shall pull away from the window and be pressed against the mold.
- (c) The material shall remain against the mold after forming. [Any evidence of the sheet dropping back indicates a loss of vacuum on the mold side. Observation of this condition shall be continued through the first anneal cycle (2 hr at 220°F).]

Cooling

Immediately after forming, the cooling and annealing cycles should be initiated. The oven temperature shall be set at 220°F. This first stage of the annealing cycle shall be maintained for a minimum of two hours. The second stage of the annealing cycle shall follow immediately and requires a minimum of 16 hours at a temperature of +170°F. The vacuum shall be maintained during the full anneal cycle.

Following annealing, the system shall be cooled slowly to room temperature to remove the visor blank. The temperature shall be below 125°F prior to attempting to remove the visor.

VISOR BLANK REMOVAL

The steep side angle of visor SK58932 makes blank removal difficult. The normal method using a vacuum to pull the visor blank from the mold does not work in this case. To remove the visor blank from the mold, proceed as follows:

- (a) Allow the mold to cool to room temperature.
- (b) Remove the fixture cover and spacing ring.
- (c) Using a large (400-watt) soldering iron, make a first cut in the plastic, as shown in Figure A5. [This cut shall be made approximately in the center of the flat base portion so that a small flat ring (2-1/4 inches wide) remains on the blank.]
- (d) Remove excess material from the outer (cone-shaped) portion of the fixture.
- (e) Make two vertical cuts with the soldering iron (180 deg apart) extending from the base of the blank up 2-1/2 inches to 3 inches toward the crown. (DO NOT scratch the mold with the iron.)
- (f) Using a hot air gun, heat the blank until it "pops" free of mold. (CAUTION: Do not rotate the blank while it is in contact with the mold.)
- (g) Remove the blank by lifting it straight up and away from the mold.

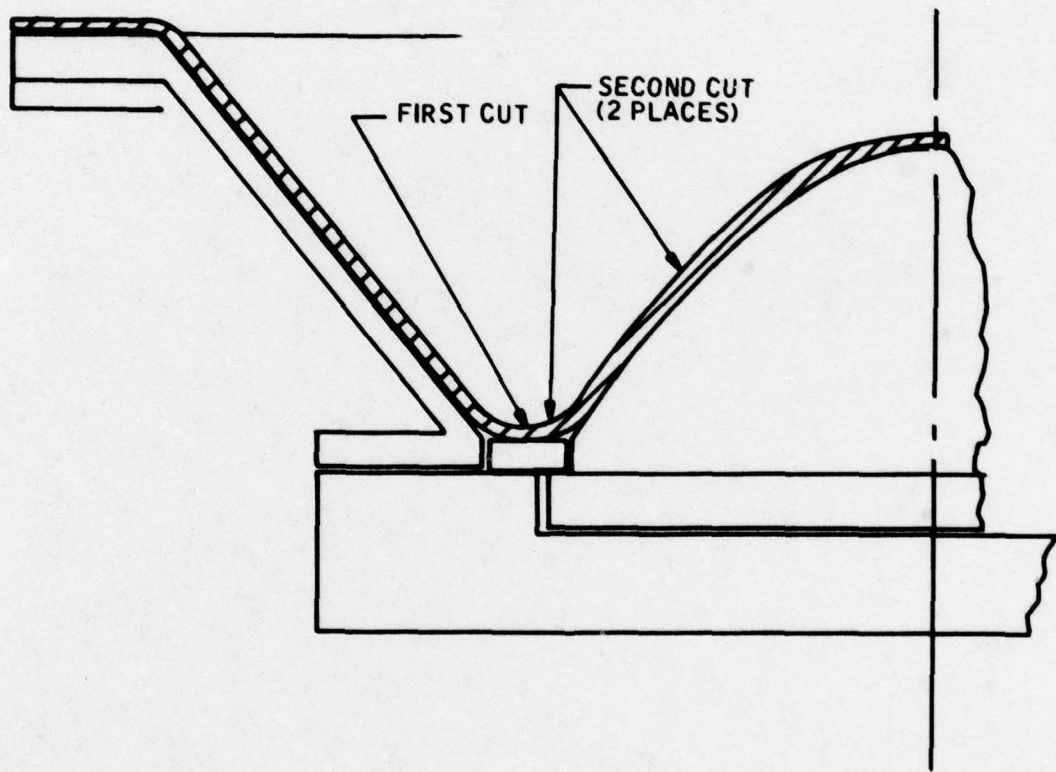

Figure A5. Visor Blank Removal from Mold