

AD-A072178

AD

TECHNICAL REPORT ARLCB-TR-79007

TECHNICAL
LIBRARY

COOPERATIVE PLANE STRAIN FRACTURE TOUGHNESS
TESTS WITH C-SHAPED SPECIMENS

J. H. Underwood
D. P. Kendall

May 1979



US ARMY ARMAMENT RESEARCH AND DEVELOPMENT COMMAND
LARGE CALIBER WEAPON SYSTEMS LABORATORY
BENÉT WEAPONS LABORATORY
WATERVLIET, N. Y. 12189

AMCMS No. 5397.OM.6350

PRON No. A1-8-P5276-AW-1A

APPROVED FOR PUBLIC RELEASE; DISTRIBUTION UNLIMITED

DISCLAIMER

The findings in this report are not to be construed as an official Department of the Army position unless so designated by other authorized documents.

The use of trade name(s) and/or manufacturer(s) does not constitute an official indorsement or approval.

DISPOSITION

Destroy this report when it is no longer needed. Do not return it to the originator.

Continued from Block 20

K_{IC} values obtained with standard compact specimens. Results show that both versions of the C-shaped specimen yield accurate values of measured K_{IC} . Normal geometric variations, as would be expected from machining of the specimen from an existing hollow cylinder, have no significant effect on the measured K_{IC} .

J. H. Underwood¹ and D. P. Kendall¹

Cooperative Plane Strain Fracture Toughness Tests with C-Shaped Specimens

REFERENCE: Underwood, J. H. and Kendall, D. P., "Cooperative Plane Strain Fracture Toughness Tests with C-Shaped Specimens," *Journal of Testing and Evaluation*, JTEVA, Vol. 6, No. 5, Sept. 1978, pp. 296-300.

ABSTRACT: The results of a cooperative test program on plane strain fracture toughness (K_{Ic}) testing with C-shaped specimens are reported and discussed. Results of 48 tests by eight laboratories using specimens with two different loading hole locations are included. The effects of specimen geometric variables, such as eccentricity of the inner and outer surfaces and nonperpendicularity of these surfaces with the specimen faces, on the measured and calculated K_{Ic} are discussed. The C-shaped specimen results are compared with measured K_{Ic} values obtained with standard compact specimens. Results show that both versions of the C-shaped specimen yield accurate values of measured K_{Ic} . Normal geometric variations, as would be expected from machining of the specimen from an existing hollow cylinder, have no significant effect on the measured K_{Ic} .

KEY WORDS: fractures (materials), strains, toughness, cooperative tests, test method, hollow cylinder

There is considerable use of high strength alloys in hollow cylinder geometries for the containment of fluids under pressure. Because of interest in this area our laboratory has proposed the use of the C-shaped specimen [1-3] for measurement of plane strain fracture toughness (K_{Ic}) in materials with cylindrical geometries. By using a portion of a ring cut from a cylinder as a K_{Ic} specimen, the fabrication of fracture toughness specimens is simplified. This can be appreciated on viewing Fig. 1, which shows the geometry of a C-shaped specimen with the outline of the maximum size compact specimen obtainable. In addition to facilitating specimen fabrication, the C-shaped specimen also permits the use of an effective specimen size about one third larger than that of a compact specimen. This can be seen by comparing W and W' in Fig. 1. An obvious disadvantage with the C-shaped specimen is that two or three compact specimens can be made from the material required for one C-shaped specimen.

Because of the interest expressed at meetings of ASTM Committee E-24 on Fracture Testing regarding K_{Ic} tests of material from cylinders, Task Group E24.01.12 on the C-Shaped Specimen for K_{Ic} Tests was established in October 1974. A cooperative test program was initiated in which the U.S. Army Benet Weapons Lab provided the test material and coordinated the testing. Concurrently, recommended modifications for inclusion of the C-

shaped specimen in the ASTM Test Method for Plane-Strain Fracture Toughness of Metallic Materials (E 399-74) were prepared by Task Group E24.01.12 and Task Group E24.01.01 on Plane Strain Fracture Toughness Testing. These recommendations were sent by ballot to E-24 members and to ASTM members at large during 1977, and the C-shaped specimen has been approved for inclusion in the 1978 revision of ASTM Method E 399-74.

The objective of this report is to describe the C-shaped specimen test program, the results, and the information obtained from the results that has been incorporated into the modification to ASTM Method E 399-74.

Test Outline

The test program was similar to but more limited in extent than that reported by McCabe [4] for the compact specimen. All

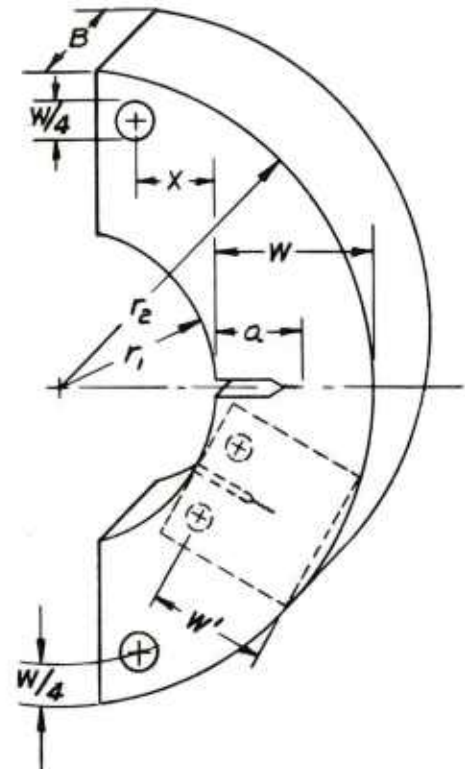

FIG. 1—C-shaped geometry and symbols.

¹Research engineers, U.S. Army Benet Weapons Lab, ARRADCOM, Watervliet, N.Y. 12189. Members of ASTM.

tests were from a single forged cylinder of a nickel-chromium-molybdenum, vacuum-degassed steel, similar to 4335 but with vanadium added. A piece of the forging with 104-mm inside diameter, 230-mm outside diameter, and 1200-mm length was heat treated with a tempering temperature of 425°C. The composition and mechanical properties of the test material are listed in Table 1. The material used here had somewhat lower strength and higher toughness than the 4340-425°C temper material used in the earlier compact K_{Ic} tests [4] because a lower carbon content and a higher nickel content decreased the strength level for a given tempering temperature. The K_{Ic} data in Table 1 were determined from specimens at both ends of the test cylinder, as shown in Fig. 2, with 23.0-mm thick compact specimens of standard geometry. The end-to-end variation in K_{Ic} is considered to be insignificant.

The test cylinder was machined to 206 mm outside diameter and rough-cut into 27 rings, as shown in Fig. 2. The rings were ground to 25.4 ± 0.1 mm thickness, rough-cut in half, and marked 1-1, 1-2, 2-1, 2-2, 3-1, and so forth. Five or ten specimen blanks, as shown in Fig. 3, were selected at random and sent to the following laboratories:

- Lab 1 U.S. Naval Surface Weapons Center, Dahlgren, Va.
- Lab 2 Babcock & Wilcox R&D Division, Alliance, Ohio
- Lab 3 Ontario Hydro Research Division, Toronto, Ontario
- Lab 4 Defense Research Establishment Valcartier, Courcellette, Quebec
- Lab 5 U.S. Army Benet Weapons Lab, Watervliet, N.Y.
- Lab 6 National Aeronautics and Space Administration (NASA) Lewis Research Center, Cleveland, Ohio
- Lab 7 U.S. Army Frankford Arsenal, Philadelphia, Pa.
- Lab 8 Lawrence Livermore Lab, Livermore, Calif.

Instructions supplied with the specimen blanks specified that the general procedure of ASTM Method E 399-74 be used where possible. Most of the test method for the compact specimen could be applied directly or with only slight modification to the C-shaped specimens because the specimens are quite similar in basic

geometry. The K_{Ic} equation specified for the C-shaped specimen is the following, based on boundary value collocation results [3]:

$$K_{Ic} B(W)^{1/2} / P = [f(a/W) (1 + 1.54 X/W + 0.50 a/W) \{1 + 0.22[1 - (a/W)^{1/2}] [1 - (r_1/r_2)]\}] \quad (1)$$

where

$$f(a/W) = 18.23(a/W)^{1/2} - 106.2(a/W)^{3/2} + 379.7(a/W)^{5/2} - 582.0(a/W)^{7/2} + 369.1(a/W)^{9/2} \quad (2)$$

and

- B = specimen thickness,
- W = width (depth),
- P = load,
- a = crack length,
- X = offset of the loading holes,
- r_1 = inner radius, and
- r_2 = outer radius.

Values for $f(a/W)$ are given in Table 2.

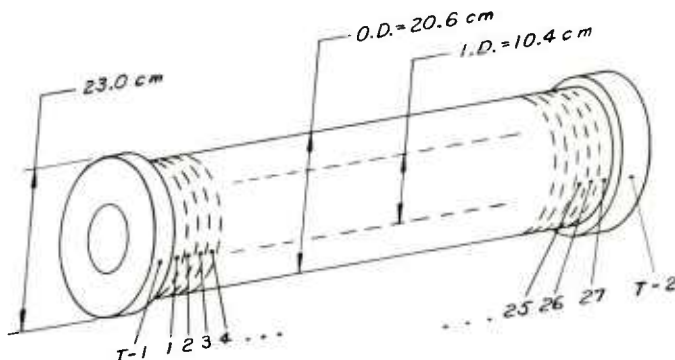
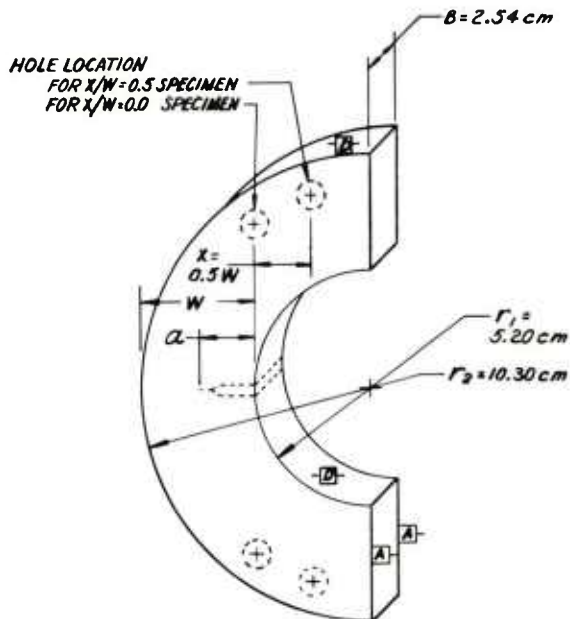

FIG. 2—Test cylinder and specimen location.

TABLE 1—Material properties.

Composition, % by weight	
Nickel	2.12
Chromium	0.99
Molybdenum	0.46
Manganese	0.58
Carbon	0.32
Vanadium	0.11
K_{Ic} , MN/m ^{3/2}	
T-1	104.4
T-1	101.4
T-1	105.7
T-2	104.0
T-2	103.7
T-2	105.1
Mean	104.0
Standard deviation	1.49
0.1% yield stress, MPa	1290
0.2% yield stress, MPa	1320
Tensile stress, MPa	1460
Elongation, %	9
Reduction in area, %	32
Hardness, HRC	43



1. \square SURFACES \parallel WITHIN $0.1 W$ T.I.R.
2. \square \perp \square WITHIN $0.02 W$ T.I.R.

FIG. 3—C-shaped specimen blanks.

TABLE 2—Values for $f(a/W)$.

a/W	$f(a/W)$	a/W	$f(a/W)$
0.450	6.32	0.505	7.45
0.455	6.42	0.510	7.57
0.460	6.51	0.515	7.69
0.465	6.60	0.520	7.81
0.470	6.70	0.525	7.94
0.475	6.80	0.530	8.07
0.480	6.90	0.535	8.20
0.485	7.01	0.540	8.34
0.490	7.11	0.545	8.48
0.495	7.22	0.550	8.62
0.500	7.33		

It was left to the laboratories to choose one of the two loading hole locations, that is, $X/W = 0.5$ or 0.0 . Roughly equal numbers of each type were tested.

Two important concerns regarding the specimen dimensions came to light during the test program. They relate to the accuracy of fabrication of the parent cylinder and the specimen blanks from the cylinder, both of which can have a direct effect on the test results. The first concern is the degree of concentricity of inside to outside diameters of the parent cylinder. The test cylinder used here had up to 1.6 mm eccentricity between the centers of the inner and outer radii. This eccentricity is greater than our normal machining practice, but in an attempt to simulate normal testing practice in this program we made no attempt to control closely the fabrication of the test pieces. As one example, the inside diameter of the test cylinder was left in the as-heat-treated condition throughout the test program. The 1.6-mm eccentricity, in the worst case, would result in a total variation of 3.2 mm in the wall thickness of a given C-shaped specimen. A finite element analysis [5] described in the next section shows the effect of wall thickness variation on K_{Ic} for a C-shaped specimen. The dimensional requirement for inside diameter relative to outside diameter shown in Note 1 of Fig. 3 will be discussed in relation to the results from the finite element analysis.

The second concern is the perpendicularity of the inside and outside diameters of the specimen to the specimen faces, that is, Surfaces D relative to A in Fig. 3. The rings were cut from the

test cylinder with a power hacksaw in a manner that produced only a rough perpendicularity of Surfaces D relative to A. This procedure is likely to be common in the fabrication of C-shaped specimens. The perpendicularity of the test specimens and the requirement in Note 2 of Fig. 3 will be discussed in relation to the test results in the next section.

Discussion of Results

A total of 48 K_{Ic} tests were performed by eight labs. Figure 4 shows all of the test data as a frequency distribution. The data appear to differ somewhat from a normal distribution, which would be the distribution expected in a large sample containing only random errors. Values of K_{Ic} below the mean appear to be more likely than values above the mean. This skewed distribution apparently had no large effect on the variation of the data about the mean, as indicated by the standard deviation values listed in Table 3. The largest standard deviation noted was $5.20 \text{ MN/m}^{3/2}$ about a mean of $101.0 \text{ MN/m}^{3/2}$ for all specimens with $X/W = 0$.

Deviations in the test method used by the laboratories from that of ASTM Method E 399-74 were noted for seven tests; they are indicated by letter code. The most prevalent deviation was an a/W value greater than 0.55. Six specimens had a/W values between 0.55 and 0.58; one specimen had an a/W of 0.60. The more significant results from the test data as outlined in Table 3 are (1) the agreement within 0.4% of the mean K_{Ic} from $X/W = 0.0$ specimens with the mean K_{Ic} from $X/W = 0.5$ specimens, (2) the agreement within 2.6% of the mean K_{Ic} from all C-shaped specimens with the mean K_{Ic} from the compact specimens, and (3) the agreement within 7% of all the individual lab means with the mean K_{Ic} from all C-shaped specimens.

The effect on measured K_{Ic} of two test variables is illustrated in Fig. 5. The position of a given specimen in the original test cylinder could have an effect on K_{Ic} , primarily because of the position of the test cylinder during heat treatment. The "Specimen 1" end of the test cylinder was furthest into the furnace and was quenched first, so it could have had higher toughness. The plot of K_{Ic} versus position in Fig. 5 shows an apparent trend toward higher K_{Ic} at the Specimen 1 end, and this is supported by the linear regression line shown, but it should be noted that the regression line varies from the mean K_{Ic} by a maximum of $\pm 2\%$

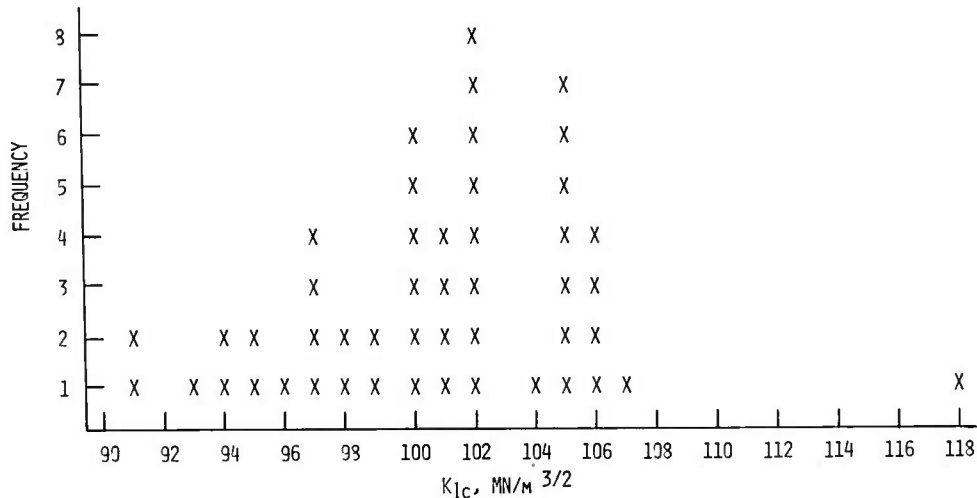

FIG. 4—Frequency distribution of K_{Ic} .

TABLE 3—The K_{Ic} results from C-shaped specimens, $MN/m^{3/2}$.

Lab Data	$X/W = 0$ Specimens					$X/W = 0.5$ Specimens					
	Lab 1	Lab 2	Lab 3	Lab 6	Lab 8	Lab 3	Lab 4	Lab 5	Lab 6	Lab 7	Lab 8
Test 1	100.1	100.0	100.3	101.7 ^{a,b}	105.8 ^a	91.6	106.4	102.4	102.2	102.5	105.7 ^a
Test 2	93.7	101.3 ^c	96.0	105.2	118.5	95.9	107.2	94.6	99.1	102.8	106.7
Test 3	95.3 ^a	98.8	100.5	97.4	...	94.6	105.4	102.8	101.1	105.8	102.2 ^a
Test 4	100.3	101.8	102.2	106.4	...	98.6	104.6	99.5	100.1	105.3	...
Test 5	97.2	...	97.1	102.0 ^{a,b}	...	91.7	105.2	97.6	...	106.9	...
Lab mean	97.3	100.5	99.2	102.5	...	94.5	105.8	99.4	100.6	104.7	104.9
Standard deviation	2.90	1.35	2.58	3.51	...	2.96	1.03	3.42	1.33	1.93	2.36
Grand mean	101.2										
All specimens											
Mean	101.0					101.4					
Standard deviation	5.20					4.66					
Valid specimens											
Mean	99.8					101.2					
Standard deviation	3.34					4.76					

^a $a/W > 0.55$.

^b a at surface < 0.9 of average a .

^cSlope of P -deflection curve < 0.7 .

and that the correlation coefficient of the line is only -0.28 . So even if the variation of K_{Ic} with position is significant, the variation is quite small.

The effect on K_{Ic} of nonperpendicularity between the inside and outside diameter surfaces and the specimen faces, discussed

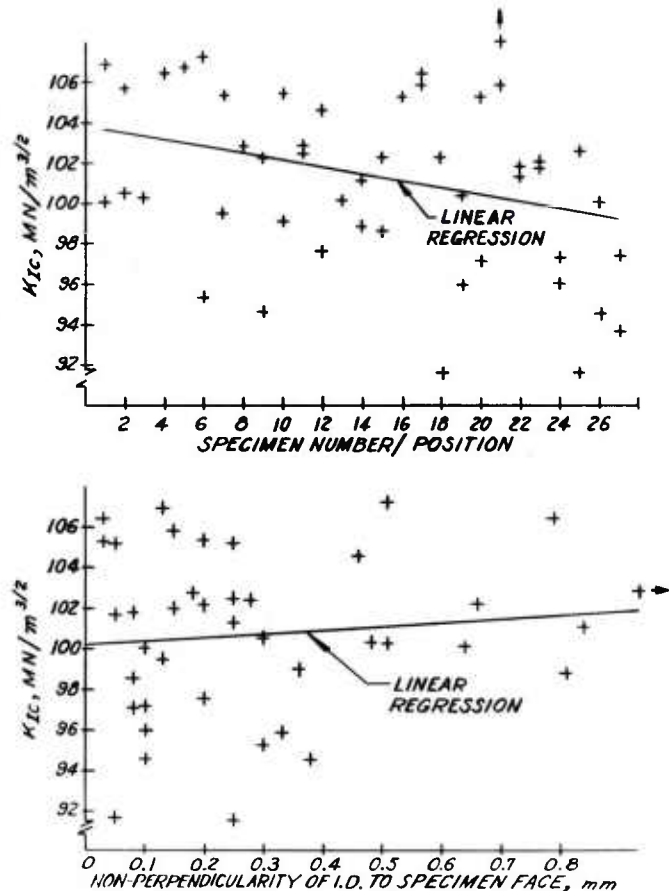

FIG. 5—Distribution of K_{Ic} with position and specimen surface perpendicularity.

in the previous section, can be observed in the lower plot of Fig. 5. Shown for each specimen are dial indicator measurements that give the total variation from perpendicularity of the inner radius relative to the specimen face, that is, Surface D relative to A in Fig. 3. The linear regression line shows a slight trend toward higher K_{Ic} with increasing nonperpendicularity. However, considering that the regression line varies only $\pm 1\%$ from the mean K_{Ic} and that the correlation coefficient of the line is $+0.12$, there appears to be no significant variation of K_{Ic} with nonperpendicularity in these tests.

The second concern discussed in the foregoing section is that of eccentricity between inside and outside diameters. In general the test results showed no significant effect of eccentricity. To verify this general impression finite element determinations of K_I were obtained for C-shaped geometries that included various degrees of eccentricity [5]. The starting geometry was a concentric cylinder with an outside to inside diameter ratio of 2.0 and an X/W of 0.5. Eccentricity was introduced so that the wall thickness at the loading hole locations varied by ± 5 and $\pm 10\%$ from that at the notch location. A summary of the results from Ref 5 for $a/W = 0.5$ is shown in Table 4. The K_I from the finite element model with no wall thickness variation is within 1% of the K_I from collocation. Furthermore and more to the point, a 10% variation in wall thickness had no significant effect on K_I . Although a K_{II} of 4% of K_I was predicted by the finite element model for the case of 10% variation in wall thickness, there was no associated change in K_I .

One of the laboratories, NASA Lewis Research Center, performed a particularly thorough series of measurements and

TABLE 4—Effect of wall thickness variation on K_I .

Wall Thickness Variation at Loading Holes, %	$K_I B(W)^{1/2} P$	
	Collocation, Eq 1	Finite Element, Ref 5
0	15.29	15.14
± 5	...	15.16
± 10	...	15.14

analyses [6] as part of its contribution to the cooperative test program and obtained results pertinent to the two specimen geometric variables just discussed, that is, nonperpendicularity and eccentricity of the specimen surfaces. Careful measurements of specimen displacement were made during the K_{Ic} tests and were compared with displacements determined from a collocation analysis. For the specimens tested, which had wall thickness variations of up to 2.5 mm and nonperpendicularity of curved to flat surfaces of up to 2.1 deg (or 0.9 mm in the terms of Fig. 5), there was good agreement between experiment and analysis, and there was no apparent effect of these variations in geometry.

Conclusions

Based on the analysis of the test results the C-shaped specimen appears to provide a good measure of K_{Ic} , and the specimen can be recommended for addition to ASTM Method E 399-74. No significant differences from the mean value were noted in the K_{Ic} measurements, which involved C-shaped specimens with two loading hole locations and a range of a/W values. The mean value of K_{Ic} from the C-shaped specimens was in good agreement with that from compact specimens of the same material.

Because the C-shaped specimen is intended primarily for fabrication from existing cylinders with no additional machining of inside and outside diameter surfaces, the dimensional accuracy of the specimen is more difficult to control than otherwise would be the case. The dimensional requirements indicated by the notes in Fig. 3 involve likely sources of error in K_{Ic} tests. The results from the tests and analyses described here show that, if these requirements are met, no significant error in K_{Ic} from these sources will occur. These eccentricity and perpendicularity requirements have been included in the modification to ASTM Method E 399-74.

Finally, some procedures in K_{Ic} testing with C-shaped specimens were improved as the result of the cooperative tests, and the improved procedures were included in the modification to ASTM

Method E 399-74. The procedures for measuring W and X require that the measurements be the average of readings on both sides of the specimen and, in the case of W , immediately adjacent to the notch. By using these procedures values of X and W with the required accuracy for K_{Ic} determination can be obtained, while at the same time specimens can be fabricated from existing cylinders without the need for high-precision machining. This is possible, in the case of the dimension W for instance, because the average value of W at the notch location is the value that affects K_{Ic} , whereas the W dimension away from the notch has surprisingly little effect on K_{Ic} .

Acknowledgments

The authors are pleased to acknowledge the help of Mr. John Zalinka of Benet Labs in coordinating the test program, Mr. Richard Farrara of Benet Labs in providing and preparing the test material, and of course the participating labs for their proficient and timely testing work.

References

- [1] Kendall, D. P. and Hussain, M. A., *Experimental Mechanics*, Vol. 12, April 1972, pp. 184-189.
- [2] Underwood, J. H., Scanlon, R. D., and Kendall, D. P., in *Fracture Analysis, STP 560*, American Society for Testing and Materials, Philadelphia, 1974, pp. 81-91.
- [3] Underwood, J. H. and Kendall, D. P., in *Developments in Fracture Mechanics Test Methods Standardization, STP 632*, W. F. Brown, Jr. and J. G. Kaufman, Eds., American Society for Testing and Materials, Philadelphia, 1977, pp. 25-38.
- [4] McCabe, D. E., *Journal of Materials*, Vol. 7, No. 4, Dec. 1972, pp. 449-454.
- [5] Kapp, J. A., Pflagl, G. A., and Underwood, J. H., *International Journal of Fracture*, Vol. 13, No. 5, Oct. 1977, pp. 721-724.
- [6] Buzzard, R. J. and Fisher, D. M., "C-Shaped Specimen Plane Strain Fracture Toughness Tests," NASA TM 73731, National Aeronautics and Space Administration Lewis Research Center, Cleveland, Ohio, July 1977.

WATERVLIET ARSENAL INTERNAL DISTRIBUTION LIST

	<u>NO. OF COPIES</u>
COMMANDER	1
DIRECTOR, BENET WEAPONS LABORATORY	1
CHIEF, DEVELOPMENT ENGINEERING BRANCH	1
ATTN: DRDAR-LCB-DA	1
-DM	1
--DP	1
-DR	1
-DS	1
-DC	1
CHIEF, ENGINEERING SUPPORT BRANCH	1
CHIEF, RESEARCH BRANCH	2
ATTN: DRDAR-LCB-RA	1
-RC	1
-RM	1
-RP	1
TECHNICAL LIBRARY	5
TECHNICAL PUBLICATIONS & EDITING UNIT	2
DIRECTOR, OPERATIONS DIRECTORATE	1
DIRECTOR, PROCUREMENT DIRECTORATE	1
DIRECTOR, PRODUCT ASSURANCE DIRECTORATE	1

NOTE: PLEASE NOTIFY DIRECTOR, BENET WEAPONS LABORATORY, ATTN:
DRDAR-LCB-TL, OF ANY REQUIRED CHANGES.

EXTERNAL DISTRIBUTION LIST (CONT)

	<u>NO. OF COPIES</u>		<u>NO. OF COPIES</u>
COMMANDER US ARMY RESEARCH OFFICE P.O. BOX 12211 RESEARCH TRIANGLE PARK, NC 27709	1	COMMANDER DEFENSE DOCU CEN ATTN: DDC-TCA CAMERON STATION ALEXANDRIA, VA 22314	12
COMMANDER US ARMY HARRY DIAMOND LAB ATTN: TECH LIB 2800 POWDER MILL ROAD ADELPHIA, MD 20783	1	METALS & CERAMICS INFO CEN BATTELLE COLUMBUS LAB 505 KING AVE COLUMBUS, OHIO 43201	1
DIRECTOR US ARMY INDUSTRIAL BASE ENG ACT ATTN: DRXPE-MT ROCK ISLAND, IL 61201	1	MPDC 13919 W. BAY SHORE DR. TRAVERSE CITY, MI 49684	1
CHIEF, MATERIALS BRANCH US ARMY R&S GROUP, EUR BOX 65, FPO N.Y. 09510	1	MATERIEL SYSTEMS ANALYSIS ACTV ATTN: DRXSY-MP ABERDEEN PROVING GROUND MARYLAND 21005	1
COMMANDER NAVAL SURFACE WEAPONS CEN ATTN: CHIEF, MAT SCIENCE DIV DAHLGREN, VA 22448	1		
DIRECTOR US NAVAL RESEARCH LAB ATTN: DIR, MECH DIV CODE 26-27 (DOC LIB) WASHINGTON, D.C. 20375	1 1		
NASA SCIENTIFIC & TECH INFO FAC P.O. BOX 8757, ATTN: ACQ BR BALTIMORE/WASHINGTON INTL AIRPORT MARYLAND 21240	1		

NOTE: PLEASE NOTIFY COMMANDER, ARRADCOM, ATTN: BENET WEAPONS LABORATORY, DRDAR-LCB-TL; WATERVLIET ARSENAL, WATERVLIET, N.Y. 12189, OF ANY REQUIRED CHANGES.

EXTERNAL DISTRIBUTION LIST

	<u>NO. OF COPIES</u>		<u>NO. OF COPIES</u>
ASST SEC OF THE ARMY RESEARCH & DEVELOPMENT ATTN: DEP FOR SCI & TECH THE PENTAGON WASHINGTON, D.C. 20315	1	COMMANDER US ARMY TANK-AUTMV R&D COMD ATTN: TECH LIB - DRDTA-UL MAT LAB - DRDTA-RK WARREN, MICHIGAN 48090	1 1
COMMANDER US ARMY MAT DEV & READ. COMD ATTN: DRCD 5001 EISENHOWER AVE ALEXANDRIA, VA 22333	1	COMMANDER US MILITARY ACADEMY ATTN: CHMN, MECH ENGR DEPT WEST POINT, NY 10996	1
COMMANDER US ARMY ARRADCOM ATTN: DRDAR-TSS DRDAR-LCA (PLASTICS TECH EVAL CEN) DOVER, NJ 07801	2 1	COMMANDER REDSTONE ARSENAL ATTN: DRSMI-RB DRSMI-RRS DRSMI-RSM ALABAMA 35809	2 1 1
COMMANDER US ARMY ARRCOM ATTN: DRSAR-LEP-L ROCK ISLAND ARSENAL ROCK ISLAND, IL 61299	1	COMMANDER ROCK ISLAND ARSENAL ATTN: SARRI-ENM (MAT SCI DIV) ROCK ISLAND, IL 61202	1
DIRECTOR US Army Ballistic Research Laboratory ATTN: DRDAR-TSB-S (STINFO) ABERDEEN PROVING GROUND, MD 21005	1	COMMANDER HQ, US ARMY AVN SCH ATTN: OFC OF THE LIBRARIAN FT RUCKER, ALABAMA 36362	1
COMMANDER US ARMY ELECTRONICS COMD ATTN: TECH LIB FT MONMOUTH, NJ 07703	1	COMMANDER US ARMY FGN SCIENCE & TECH CEN ATTN: DRXST-SD 220 7TH STREET, N.E. CHARLOTTESVILLE, VA 22901	1
COMMANDER US ARMY MOBILITY EQUIP R&D COMD ATTN: TECH LIB FT BELVOIR, VA 22060	1	COMMANDER US ARMY MATERIALS & MECHANICS RESEARCH CENTER ATTN: TECH LIB - DRXMR-PL WATERTOWN, MASS 02172	2

NOTE: PLEASE NOTIFY COMMANDER, ARRADCOM, ATTN: BENET WEAPONS LABORATORY, DRDAR-LCB-TL, WATERVLIET ARSENAL, WATERVLIET, N.Y. 12189, OF ANY REQUIRED CHANGES.