

AD-A072 422

STATE UNIV OF NEW YORK AT BUFFALO
AN EXPERIMENTAL INVESTIGATION OF THE REDUCTION OF NONLINEAR EFF--ETC(U)
JUN 79 C A PALUDI, J J WHALEN

F/G 20/14

F30602-75-C-0122

UNCLASSIFIED

RADC-TR-79-148

NL

1 OF 1
AD
A072422



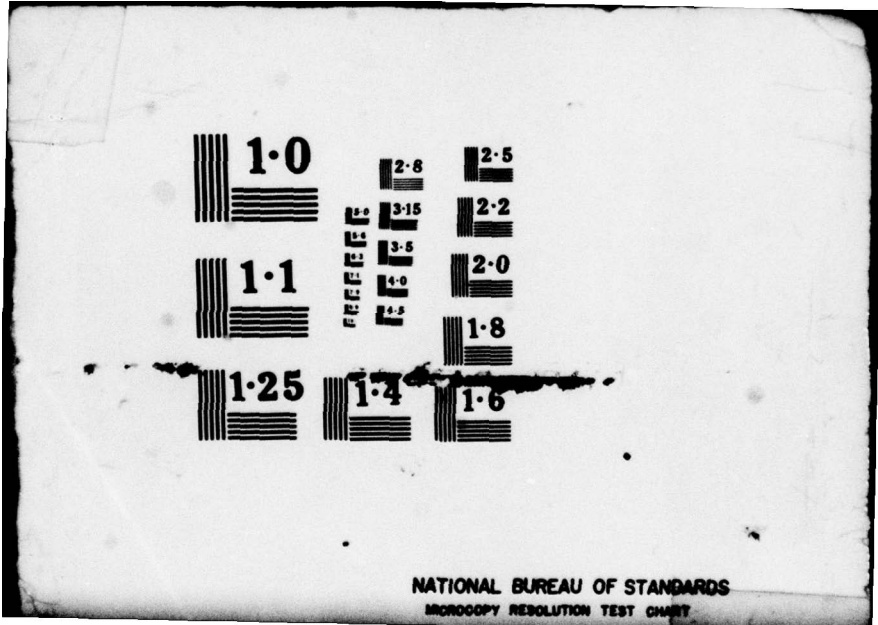

NATIONAL BUREAU OF STANDARDS
MICROCOPY RESOLUTION TEST CHART

RADC-TR-79-148
In-House Report
June 1979

EP
LEVEL II



A072422

AN EXPERIMENTAL INVESTIGATION OF THE REDUCTION OF NONLINEAR EFFECTS USING PASSIVE COMPENSATING NETWORKS

Carmen A. Paludi, Jr. (RADC/RBCT)
James J. Whalen (SUNY at Buffalo)

DDC
RECEIVED
AUG 8 1979
C

APPROVED FOR PUBLIC RELEASE; DISTRIBUTION UNLIMITED

DDC FILE COPY

ROME AIR DEVELOPMENT CENTER
Air Force Systems Command
Griffiss Air Force Base, New York 13441

79 08 06 018

RADC-TR-79-148 has been reviewed and is approved for publication.

APPROVED: *Samuel D. Zaccari*

SAMUEL D. ZACCARI
Chief, Compatibility Branch
Reliability & Compatibility Division

APPROVED: *David C. Luke*

DAVID C. LUKE, Lt Colonel, USAF
Assistant Chief
Reliability & Compatibility Division

FOR THE COMMANDER:

John P. Buss

JOHN P. BUSS
Acting Chief, Plans Office

your address has changed or if you wish to be removed from the RADC
filing list, or if the addressee is no longer employed by your organization,
please notify RADC (RADC) Griffin HSB HT 13441. This will assist us in

UNCLASSIFIED

9 Rept. for Oct 77 - Sep 78,

SECURITY CLASSIFICATION OF THIS PAGE (When Data Entered)

19 REPORT DOCUMENTATION PAGE		READ INSTRUCTIONS BEFORE COMPLETING FORM
1. REPORT NUMBER 18 RADC-TR-79-148	2. GOVT ACCESSION NO.	3. RECIPIENT'S CATALOG NUMBER
4. TITLE (and Subtitle) 6 AN EXPERIMENTAL INVESTIGATION OF THE REDUCTION OF NONLINEAR EFFECTS USING PASSIVE COMPENSATING NETWORKS	5. TYPE OF REPORT & PERIOD COVERED In-House Report Oct 77 - Sep 78	
7. AUTHOR(s) 10 Carmen A. Paludi, Jr. (RADC/RBCT) James J. Whalen (SUNY at Buffalo)	8. CONTRACT OR GRANT NUMBER(s) 15 F30602-75-C-0122	6. PERFORMING ORG. REPORT NUMBER N/A
9. PERFORMING ORGANIZATION NAME AND ADDRESS Rome Air Development Center (RBCT) Griffiss AFB NY 13441	10. PROGRAM ELEMENT, PROJECT, TASK AREA & WORK UNIT NUMBERS J.O. 233803PO 12 62 p.	
11. CONTROLLING OFFICE NAME AND ADDRESS Rome Air Development Center (RBCT) Griffiss AFB NY 13441	12. REPORT DATE 11 June 1979	
14. MONITORING AGENCY NAME & ADDRESS (if different from Controlling Office) Same 16 2338	13. NUMBER OF PAGES 50	15. SECURITY CLASS. (of this report) UNCLASSIFIED
16. DISTRIBUTION STATEMENT (of this Report) Approved for public release; distribution unlimited. 62702 F	15a. DECLASSIFICATION/DOWNGRADING SCHEDULE N/A	
17. DISTRIBUTION STATEMENT (of the abstract entered in Block 20, if different from Report) Same		
18. SUPPLEMENTARY NOTES 256 940 This effort was conducted jointly by the Rome Air Development Center and the State University of New York at Buffalo under the sponsorship of the Rome Air Development Center Post-Doctoral Program for Rome Air Development Center.		
19. KEY WORDS (Continue on reverse side if necessary and identify by block number) RFI radio frequency interference EMI electromagnetic interference EMC electromagnetic compatibility NCAP Intermodulation Products	Nonlinear Effects Nonlinear Circuit Analysis Nonlinear Modeling Nonlinear Measurements	
20. ABSTRACT (Continue on reverse side if necessary and identify by block number) This report describes an experimental investigation to determine if a procedure reported upon for reducing third order Intermodulation Products (IMP's) in an RF amplifier stage could be implemented in the laboratory. The third order IMP reduction procedure is based upon altering the RF amplifier linear out-of-band response by adding passive compensating networks. For this experiment, an RF amplifier tuned at 10 MHz was selected. The RF amplifier was excited by two CW signals at frequencies $f_1 = 9.0$ MHz and $f_2 = 9.5$ MHz in order		

DD FORM 1 JAN 73 1473

UNCLASSIFIED
SECURITY CLASSIFICATION OF THIS PAGE (When Data Entered)

256 940

JOB

UNCLASSIFIED

SECURITY CLASSIFICATION OF THIS PAGE(When Data Entered)

to obtain a third order IMP at the frequency $2f_2 - f_1 = 10$ MHz. The objective of the experiment was to determine if a significant reduction in this third order IMP could be obtained by connecting properly designed compensating networks to the basic RF amplifier stage.

A linear model for the basic RF amplifier stage was developed. This model yielded calculated results that were in relatively good agreement with measured results for the magnitude and phase of the linear transfer function V_{OUT}/V_{IN} .

Using the linear model for the basic amplifier stage, compensating networks were synthesized. The computer program NCAP and the synthesis procedure predicted that a 20 dB reduction would be obtained in the value for the third order IMP at $2f_2 - f_1 = 10$ MHz. When the compensating networks were connected to the basic RF amplifier, no significant reduction in the third order IMP at $2f_2 - f_1 = 10$ MHz was observed experimentally. A complete discussion of the results are presented.

Accession For	
NTIS GRA&I	<input checked="" type="checkbox"/>
DOC TAB	<input type="checkbox"/>
Unclassified	<input type="checkbox"/>
Justification	
By	
Distribution/	
Availability Codes	
Dist.	Avail and/or special

UNCLASSIFIED

SECURITY CLASSIFICATION OF THIS PAGE(When Data Entered)

PREFACE

This effort was conducted jointly by the Rome Air Development Center and the State University of New York at Buffalo under the sponsorship of the Rome Air Development Center Post-Doctoral Program for Rome Air Development Center.

The RADC Post-Doctoral Program is a cooperative venture between RADC and some sixty-five universities eligible to participate in the program. Syracuse University (Department of Electrical Engineering), Purdue University (School of Electrical Engineering), Georgia Institute of Technology (School of Electrical Engineering), and State University of New York at Buffalo (Department of Electrical Engineering) act as prime contractor schools with other schools participating via sub-contracts with the prime schools. The U.S. Air Force Academy (Department of Electrical Engineering), Air Force Institute of Technology (Department of Electrical Engineering), and the Naval Post Graduate School (Department of Electrical Engineering) also participate in the program.

The Post-Doctoral Program provides an opportunity for faculty at participating universities to spend up to one year full time on exploratory development and problem-solving efforts with the post-doctorals splitting their time between the customer location and their educational institutions. The program is totally customer-funded with current projects being undertaken for Rome Air Development Center (RADC), Space and Missile Systems Organization (SAMSO), Aeronautical System Division (ASD), Electronics Systems Division (ESD), Air Force Avionics Laboratory (AFAL), Foreign Technology Division (FTD), Air Force Weapons Laboratory (AFWL), Armament Development and Test Center (ADTC), Air Force Communications Service (AFCS), Aerospace Defense

Command (ADTC), HQ USAF, Defense Communications Agency (DCA), Navy, Army, Aerospace Medical Division (AMD), and Federal Aviation Administration (FAA).

Further information about the RADC Post-Doctoral Program can be obtained from Mr. Jacob Scherer, RADC/RBC, Griffiss AFB, NY, 13441, telephone Autovon 587-2543, Commercial (315) 330-2543.

This work was performed as part of a larger effort aimed at reducing electromagnetic interference (EMI) effects, i.e. reducing nonlinear effects in-band by modifying the linear out-of-band response. The responsible person at SUNY at Buffalo was Dr. James J. Whalen. Mr. Carmen A. Paludi, Jr. was the project engineer at RADC.

Dr. Whalen received the B.E.E. degree from Cornell University, Ithaca, New York, and the M.S.E. and Ph.D. degrees in Electrical Engineering from the Johns Hopkins University, Baltimore, Maryland in 1962 and 1969 respectively. After completion of his undergraduate work, he served as an officer for three years in the U.S. Navy. In 1961 he joined the staff of Carlyle Barton Laboratory, The Johns Hopkins University where he was an Associate Research Scientist. He carried out solid state research projects at microwave and millimeter wave frequencies in the areas of low temperature spectroscopy, masers, and semiconductor devices. In 1970 he joined the Department of Electrical Engineering, State University of New York at Buffalo where he is presently an Associate Professor of Electrical Engineering. At SUNY at Buffalo he teaches courses on semiconductor physics and electronic fabrication of special purpose transistors and the electromagnetic vulnerability properties of UHF/microwave transistors.

He is a member of the Institute of Electrical and Electronics Engineers, the American Physical Society, Eta Kappa Nu, Tau Beta Pi, and Sigma Xi.

Mr. Paludi is an Electronic Engineer for the Reliability and Compatibility Division of the Rome Air Development Center. He received his B.S.E.E. from Clarkson College of Technology, Potsdam, New York in 1975, and is currently pursuing a M.S.E.E. degree from Syracuse University, Syracuse, New York.

Areas of work include analysis and modeling of electromagnetic interference (EMI) effects at the subsystem level and applications of the Nonlinear Circuit Analysis Program (NCAP). He is a member of the Institute of Electrical and Electronics Engineers.

ABSTRACT

An experimental investigation was undertaken to determine if a procedure previously reported upon for reducing third order Intermodulation Products (IMP's) in an RF amplifier stage could be implemented in the laboratory. The third order IMP reduction procedure is based upon altering the RF amplifier linear out-of-band response by adding passive compensating networks. For the experiment, a RF amplifier tuned at 10 MHz was selected. The RF amplifier was excited by two CW signals at frequencies $f_1 = 9.0$ MHz and $f_2 = 9.5$ MHz in order to obtain a third order IMP at the frequency $2f_2 - f_1 = 10$ MHz. The objective of the experiment was to determine if a significant reduction in this third order IMP could be obtained by connecting properly designed compensating networks to the basic RF amplifier stage.

A linear model for the basic RF amplifier stage was developed for the frequency range $f_2 - f_1$ to $2f_2$. By including parasitic effects associated with passive components and modifying the transistor parameter values, the model for the RF amplifier yielded calculated results that agreed with experimental results within 4 dB or less in magnitude and 40° or less in phase for the linear transfer function V_{OUT}/V_{IN} .

Using the linear model developed for the basic RF amplifier stage, compensating networks were synthesized. The computer program NCAP predicted that a 20 dB reduction would be obtained in the value for the third order IMP at $2f_2 - f_1 = 10$ MHz. When the compensating networks were connected to the basic RF amplifier stage in the laboratory, little (if any) reduction in the third order IMP at $2f_2 - f_1 = 10$ MHz was observed experimentally. The important compensating element values were varied up to $\pm 25\%$ about the

nominal design value. Again no significant reduction in the third order IMP at $2f_2 - f_1 = 10$ MHz was observed experimentally.

The main reason why the third order IMP reduction scheme investigated did not yield the 20 dB reduction predicted by NCAP appears to be that the synthesis procedure used to determine compensating network component values depends critically upon the accuracy of the linear model developed for the basic RF amplifier stage. A rudimentary analysis suggests that a linear model for the basic RF amplifier stage may have to be developed that can predict magnitude response within ± 0.3 dB and phase response within $\pm 2^\circ$ over the frequency range $f_2 - f_1$ to $2f_2$. Thus a significant improvement in modeling capability appears necessary. In particular, a significant improvement in models for the passive components such as resistors, capacitors, and inductors used in the basic RF amplifier stage must be achieved. Parasitic elements such as lead inductance, fringing capacitance, and series and/or shunt resistances must be modeled carefully and accurately over the frequency range $f_2 - f_1$ to $2f_2$ (which will typically be many octaves). In addition, it also may be necessary to model Printed Circuit Board (PCB) wiring effects such as the distributed capacitances and inductances in two wire systems and the mutual capacitances and inductances in multi-wire systems. Efforts to develop improved models in these two areas are recommended. When improved modeling techniques have been developed that accurately account for parasitic effects in passive components over the frequency range 1 to 1000 MHz and for distributed effects associated with multi-conductor PCB wiring, it would be appropriate to synthesize new passive compensating networks to reduce the third order IMP in the RF amplifier stage and to make another attempt to determine how well the new networks perform experimentally.

ACKNOWLEDGEMENTS

The authors are indebted to Dr. Kendall L. Su of Georgia Institute of Technology for his invaluable contributions throughout the duration of this experimental investigation. His technical consultation provided insight into several problems encountered and, most important, provided us with the compensating networks and element values.

We also wish to acknowledge Dr. Donald Weiner of Syracuse University and Messrs. John Spina and Daniel Warren of RADC/RBCT for providing the technical direction for this experiment, their encouragement and support, and their comments on this report.

The authors of this report thank Messrs. Ta Fang Fang and Andrew Chu of SUNY at Buffalo, and Mr. Jon Valente of RADC/RBCT for their supporting effort in computer programming; Mr. Andrew Drozd for his drafting support, Ms. Carol Frank for typing this report.

TABLE OF CONTENTS

		<u>PAGE</u>
SECTION 1	Introduction	1
SECTION 2	Modeling of RF Amplifier and Compensating Networks	8
SECTION 3	Experimental System and Procedures	28
SECTION 4	Experimental and Calculated Values for the RF Amplifier Nonlinear Transfer Functions	35
SECTION 5	Conclusions	40
APPENDIX A1	Determining Experimental Values for the RF Amplifier Nonlinear Transfer Functions	45
REFERENCES		49

ILLUSTRATIONS

Figure	Page
1. Block diagram of system	2
2. Resulting spectrum at the output of the RF amplifier	3
3. Block diagram of basic reduction idea	5
4. Circuit schematic for BJT RF amplifier	10
5. Incremental nonlinear T-model for BJT used in NCAP	11
6. Experimental system for measuring amplifier linear transfer function V_{TEST}/V_{REF} in the HF/VHF frequency region	13
7. Linear transfer function V_{TEST}/V_{REF} (magnitude)	14
8. Linear transfer function V_{TEST}/V_{REF} (phase)	15
9. HF/VHF equivalent circuit for the 2N5109-2 BJT RF amplifier used to calculate the linear transfer function V_{TEST}/V_{REF}	20
10. Schematic of compensating network Y3	21
11. Model of compensating network Y3	22
12. Schematic of compensating network Y1	23
13. Model of compensating network Y1	23
14. Schematic and model of series L-C tuned for minimum impedance at 0.5 MHz	24
15. Schematic and model of series L-C tuned for minimum impedance at 19 MHz	25
16. Composite model for RF amplifier and compensating networks	26
17. Experimental system for measuring $H_3(-f_1, f_2, f_2)$	30
18. Line drawing of photograph from spectrum analyser display of RF amplifier power density spectrum	31
A1. Basic circuit configuration analysed by the computer program NCAP. The frequency $f = rf_1 + sf_2$ where r and s take on integer values 0,1,2,3,...	46

TABLES

Table	Page
I. NCAP input parameters for 2N5109 bipolar junction transistor	12
II. NCAP calculated nonlinear transfer functions	27
III. Equations relating experimental RF amplifier input and output voltages to the nonlinear transfer functions for the two tone case	32
IV. Experimental and Calculated Values for the RF amplifier nonlinear transfer functions (without emitter bypass networks)	36
V. Experimental and Calculated Values for the RF amplifier nonlinear transfer functions (with emitter bypass networks)	39

SECTION 1

Introduction

An important interference problem in communications receivers is the one caused by third order intermodulation product (IMP) effects. One way in which 3rd order IMP's may cause interference in a receiver is illustrated in Fig. 1. The receiver shown in Fig. 1 consists of an RF stage tuned at 10 MHz with an RF passband of ± 1 MHz followed by a mixer stage driven by a local oscillator (LO) stage. The LO signal frequency is 10 MHz plus the IF frequency. A typical IF frequency might be 1% of the frequency to which the RF stage is tuned. (For the receiver shown in Fig. 1, the IF frequency might be 0.1 MHz.) The output of the mixer stage is the input to the tuned IF amplifier. The mixer output signals with frequency components within the IF passband will be amplified by the IF amplifier and subsequently demodulated by the 2nd detector stage. For the receiver shown in Fig. 1, only the mixer output signals with frequency components at the 0.1 MHz IF frequency would be so processed by the IF amplifier and 2nd detector to produce an output response. Clearly the receiver is structured to accept a desired input signal with an RF frequency at 10 MHz and to produce a desired response at the 2nd detector output.

Unfortunately an undesired response at the 2nd detector output can also be produced by two undesired signals which are coupled into the RF stage as shown in Fig. 1. If two receiver input signals have frequencies f_1 and f_2 and satisfy the condition $2f_2 - f_1 = 10$ MHz (or the condition $2f_1 - f_2 = 10$ MHz), then the output of the RF stage will have the frequency spectrum illustrated in Fig. 2. For the case illustrated in Fig. 1, the input signal frequencies are $f_1 = 9.0$ MHz and $f_2 = 9.5$ MHz. The signal with frequency

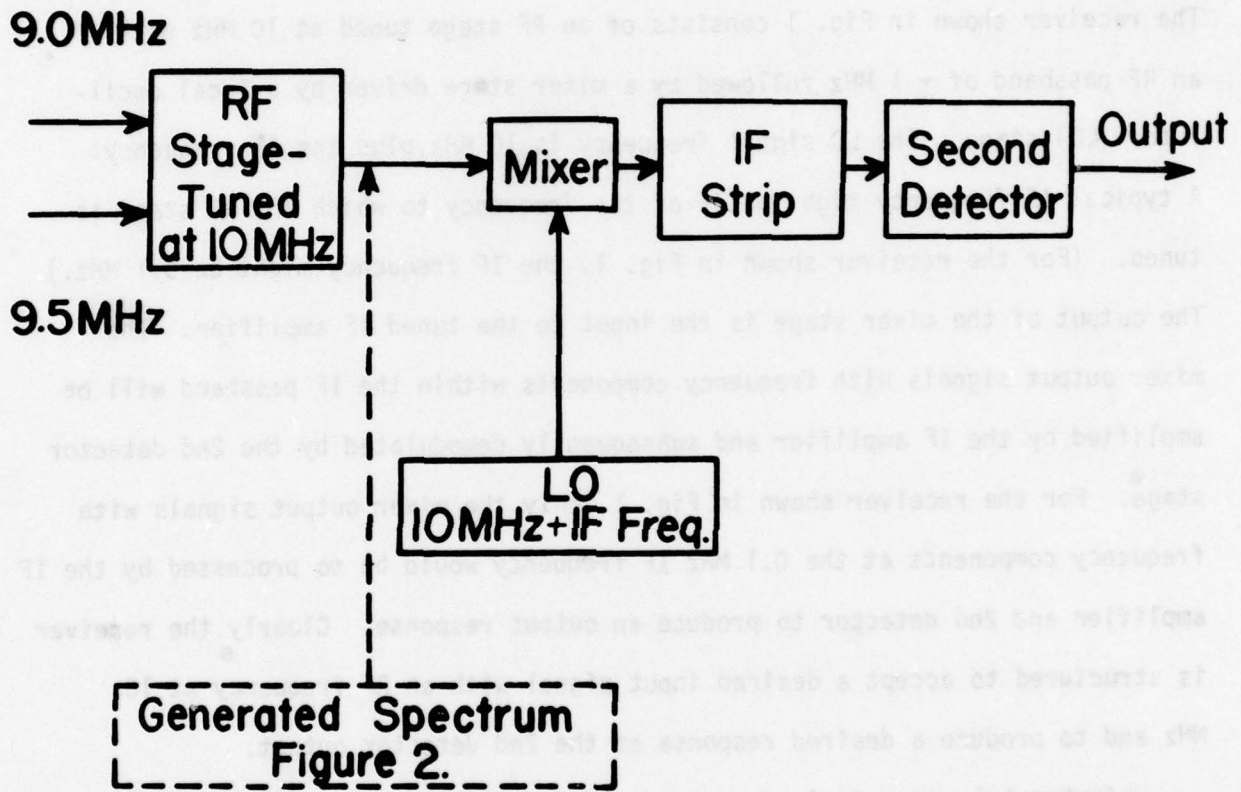

Fig. 1. Block Diagram of System

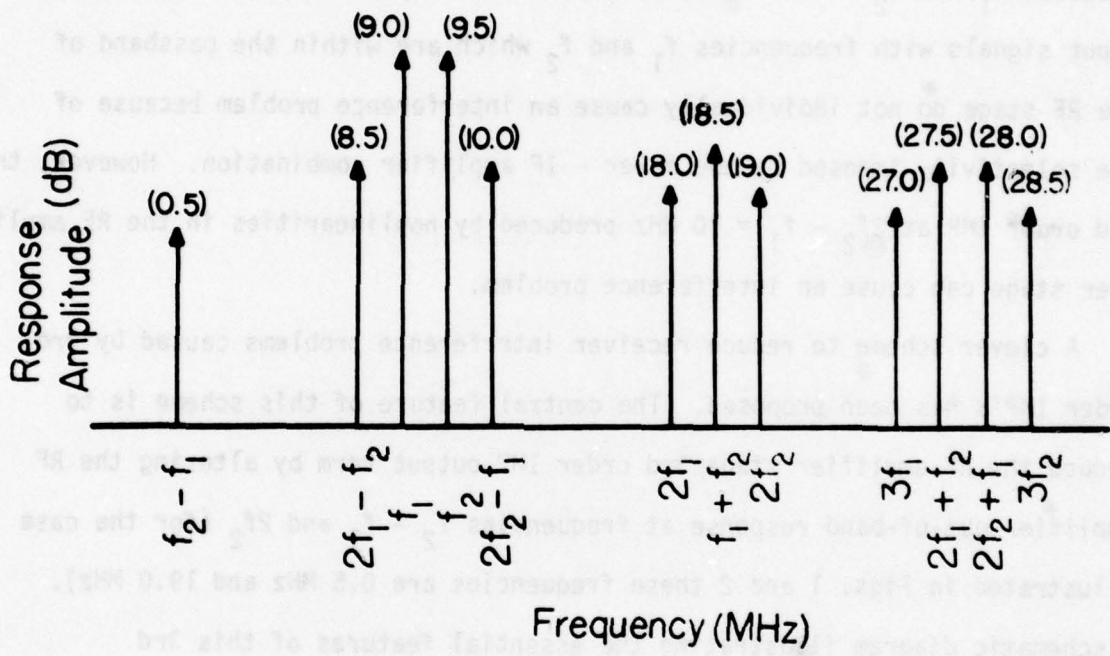

Fig. 2. Resulting Spectrum at the Output of the RF Amplifier

$2f_2 - f_1 = 10$ MHz at the RF amplifier stage output is a 3rd order IMP generated by nonlinearities in the RF stage. This interference signal will be processed by the mixer stage, IF amplifier, and 2nd detector in exactly the same manner as a desired signal at 10 MHz. The result will be an undesired 2nd detector output caused by the two interfering signals at frequencies f_1 and f_2 at the receiver input. The important point is that two input signals with frequencies f_1 and f_2 which are within the passband of the RF stage do not individually cause an interference problem because of the selectivity imposed by the mixer - IF amplifier combination. However, the 3rd order IMP at $2f_2 - f_1 = 10$ MHz produced by nonlinearities in the RF amplifier stage can cause an interference problem.

A clever scheme to reduce receiver interference problems caused by 3rd order IMP's has been proposed. The central feature of this scheme is to reduce the RF amplifier stage 3rd order IMP output term by altering the RF amplifier out-of-band response at frequencies $f_2 - f_1$ and $2f_2$ (for the case illustrated in Figs. 1 and 2 these frequencies are 0.5 MHz and 19.0 MHz). A schematic diagram illustrating the essential features of this 3rd order IMP reduction scheme is given in Fig. 3. The original RF amplifier stage is modified by adding two compensating networks designated as Y1 and Y3. The compensating network Y1 is connected directly across the input terminals of the RF amplifier stage. The compensating network Y3 is connected between the RF stage output terminal and input terminal. Both compensating networks consist entirely of passive components. Procedures for synthesizing the compensating networks Y1 and Y3 have been developed by K. L. Su and have been reported upon previously.^{3,4}

Both theoretical and analytical results indicate that a substantial reduction in the 3rd order IMP term at the RF amplifier output can be obtained by

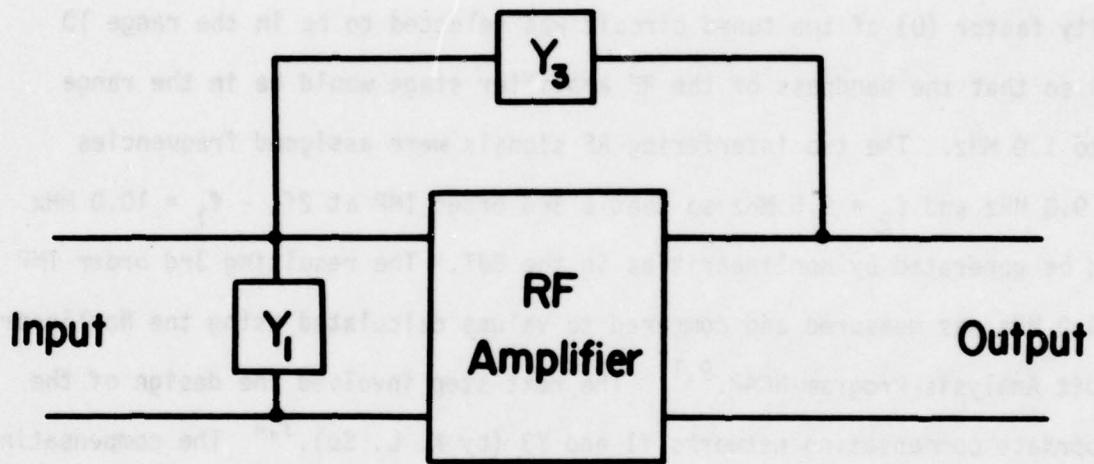

Fig. 3. Block Diagram of Basic Reduction Scheme

connecting the appropriate compensating networks Y1 and Y3. Thus an experimental investigation to determine what reduction in 3rd order IMP could actually be obtained in the laboratory was undertaken. A basic tuned RF amplifier stage was selected for the investigation. The stage consisted of a single discrete bipolar junction transistor (BJT) followed by a single parallel L-C filter tuned at 10.0 MHz connected to a 50^{Ω} load resistor. The quality factor (Q) of the tuned circuit was selected to be in the range 10 to 20 so that the bandpass of the RF amplifier stage would be in the range 0.5 to 1.0 MHz. The two interfering RF signals were assigned frequencies $f_1 = 9.0$ MHz and $f_2 = 9.5$ MHz so that a 3rd order IMP at $2f_2 - f_1 = 10.0$ MHz would be generated by nonlinearities in the BJT. The resulting 3rd order IMP at 10.0 MHz was measured and compared to values calculated using the Nonlinear Circuit Analysis Program NCAP.^{9,11} The next step involved the design of the appropriate compensating networks Y1 and Y3 (by K. L. Su).^{3,4} The compensating networks were connected as shown in Fig. 3. New values for the 3rd order IMP term at 10.0 MHz were measured and compared to values calculated by the computer program NCAP. The experimental and calculated values for the 3rd order IMP term at 10.0 MHz without and with the compensating networks Y1 and Y3 will be presented and discussed. It is appropriate at this point to comment that little reduction in the 3rd order IMP at 10.0 MHz was obtained experimentally. The main reasons why this experimental result was obtained will be discussed.

This report is organized in the following manner. In Section 2 circuit models for the RF amplifier stage and the compensating networks Y1 and Y3 will be described in detail for two reasons. One reason is that the computer program NCAP requires a detailed circuit model in order to calculate nonlinear

terms such as 3rd order IMP's. Values for the transistor parameters in the NCAP model for a BJT are required. Also needed is an accurate linear model for the passive part of the RF amplifier network (which includes the compensating networks). The accuracy of the nonlinear terms calculated by the computer program NCAP depends more critically upon the accuracy of the linear network model than upon any other factor. The second reason for describing in Section 2 the circuit models in detail is that the procedure for synthesizing the values of the components in the compensating networks also depends critically upon the accuracy of the linear circuit model. In Section 3, the experimental system and procedures used to measure 3rd order IMP's will be described. A comparison of experimental and theoretical results for the 3rd order IMP's with and without the compensating networks will be given in Section 4. A discussion and summary of results is given in the last section.

SECTION 2

Modeling of RF Amplifier and Compensating Networks

A technique for reducing nonlinear effects in-band, by modifying the linear out-of-band response has been developed by Su, Weiner and Spina.^{1,2,3,4} To determine the correlation between the experimental results and the simulation results, a circuit model must be developed. This model will be used by the Nonlinear Circuit Analysis Program (NCAP)⁹ to calculate how much reduction in nonlinear effects can be attained.

The first step was designing and constructing the RF amplifier. An RCA 2N5109 RF transistor was selected. The amplifier is a single stage with a tuned output at 10 MHz. Conventional RF design criteria were followed in constructing the amplifier. Once construction was completed the modeling phase was initiated. Figure 4 shows the circuit to be modeled.

NCAP requires a detailed linear circuit model for the RF amplifier and compensating networks. Since the transistor is a nonlinear device, an accurate model for it is required by NCAP. The computer program NCAP has such a model for the bipolar junction transistor (BJT) built into its code. This model is known as the "nonlinear T" model and is shown in Fig. 5. To use this model, sixteen parameters are required as input data. Values for these parameters were determined using techniques previously reported upon.^{5,6,8,10} These parameters, their descriptions and values are listed in Table I.

NCAP also requires a detailed model for the passive linear circuit. Such a model can be developed by comparing experimental and calculated results for the RF amplifier linear transfer functions. The experimental system illustrated in Figure 6 was assembled to measure the linear transfer function V_{TEST}/V_{REF} .

Experimental results for the magnitude and phase of V_{TEST}/V_{REF} are shown in Figures 7 and 8. Also shown in these figures are the calculated results for V_{TEST}/V_{REF} obtained using the detailed circuit model shown in Figure 9. The detailed circuit model includes many parasitic elements. Why these elements must be included will now be discussed.

Values for V_{TEST}/V_{REF} were calculated initially using a circuit model simpler than that shown in Figure 9. The passive linear components were modeled initially as they appear in the circuit schematic shown in Figure 4. With the circuit data taken from Figure 4 and the transistor parameters taken from Table I, the computer program NCAP was used to compute the linear transfer function V_{TEST}/V_{REF} . The comparison between the initial calculated values (which are not shown) and the experimental values for the magnitude of V_{TEST}/V_{REF} indicated significant deviations, i.e. on the order of 10 dB. Deviations this large are unacceptable because it is extremely important to have the data for the linear (first order) transfer function predicted by NCAP agree with the measured data.

The reason for this is that higher order transfer functions calculated by NCAP depend on the values calculated for all lower order transfer functions. If the linear model is not accurate, significant errors will accrue in higher order calculations.

Since the measurement system was calibrated, it accounted for no more than 2% of the deviation. Thus the main source of the observed deviations was from the component models and the device parameter values.

Re-evaluation of the transistor parameters indicates several deficiencies in our initial modeling. First consider the transistor operating temperature. Although the power dissipation (250 mW) at a bias point of $I_E = 50$ mA and

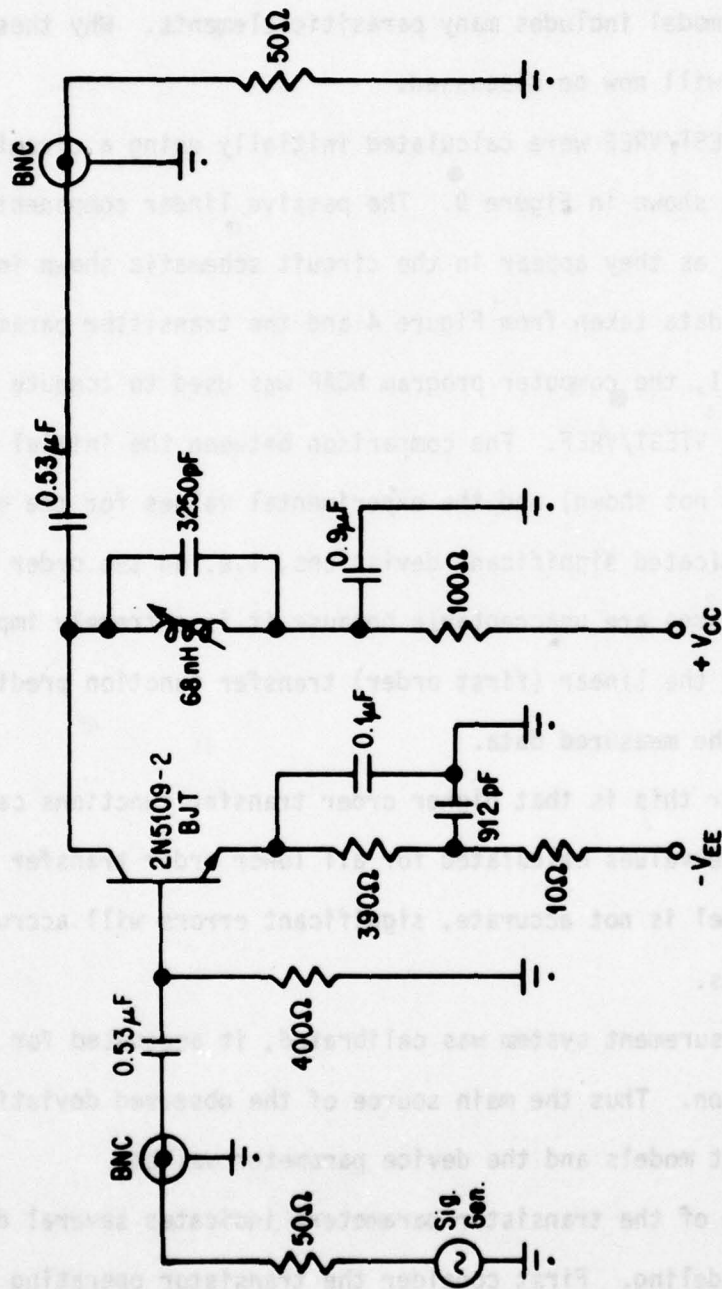

Fig. 4. Circuit Schematic for BJT RF Amplifier.

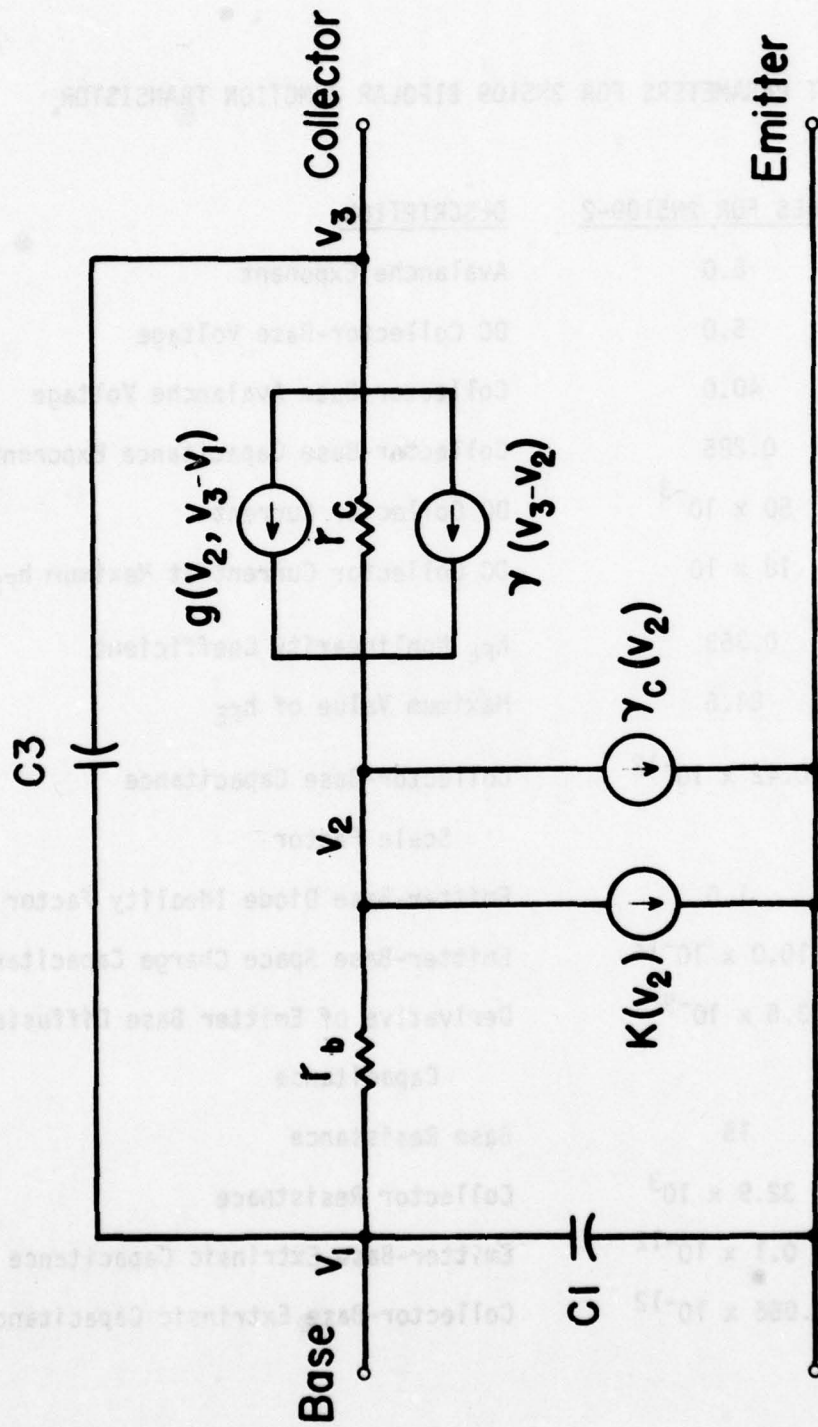

Fig. 5. Incremental Non-linear T-Model for BJT Used in NCAP

TABLE I

NCAP INPUT PARAMETERS FOR 2N5109 BIPOLAR JUNCTION TRANSISTOR

<u>PARAMETER</u>	<u>VALUES FOR 2N5109-2</u>	<u>DESCRIPTION</u>
n	6.0	Avalanche Exponent
$V_{CB}(V)$	5.0	DC Collector-Base Voltage
$V_{CBO}(V)$	40.0	Collector-Base Avalanche Voltage
μ	0.285	Collector-Base Capacitance Exponent
$I_C(A)$	50×10^{-3}	DC Collector Current
$I_{C_{MAX}}(A)$	18×10	DC Collector Current at Maximum h_{FE}
a	0.363	h_{FE} Nonlinearity Coefficient
$h_{FE_{MAX}}$	84.6	Maximum Value of h_{FE}
$K(F \cdot V^{-5})$	0.42×10^{-12}	Collector-Base Capacitance Scale Factor
n	1.0	Emitter-Base Diode Ideality Factor
$C_{je}(F)$	10.0×10^{-12}	Emitter-Base Space Charge Capacitance
$C'd(F/A)$	3.6×10^{-9}	Derivative of Emitter Base Diffusion Capacitance
$r_b(\Omega)$	15	Base Resistance
$r_c(\Omega)$	32.9×10^3	Collector Resistance
$C_1(F)$	0.1×10^{-12}	Emitter-Base Extrinsic Capacitance
$C_3(F)$	0.056×10^{-12}	Collector-Base Extrinsic Capacitance

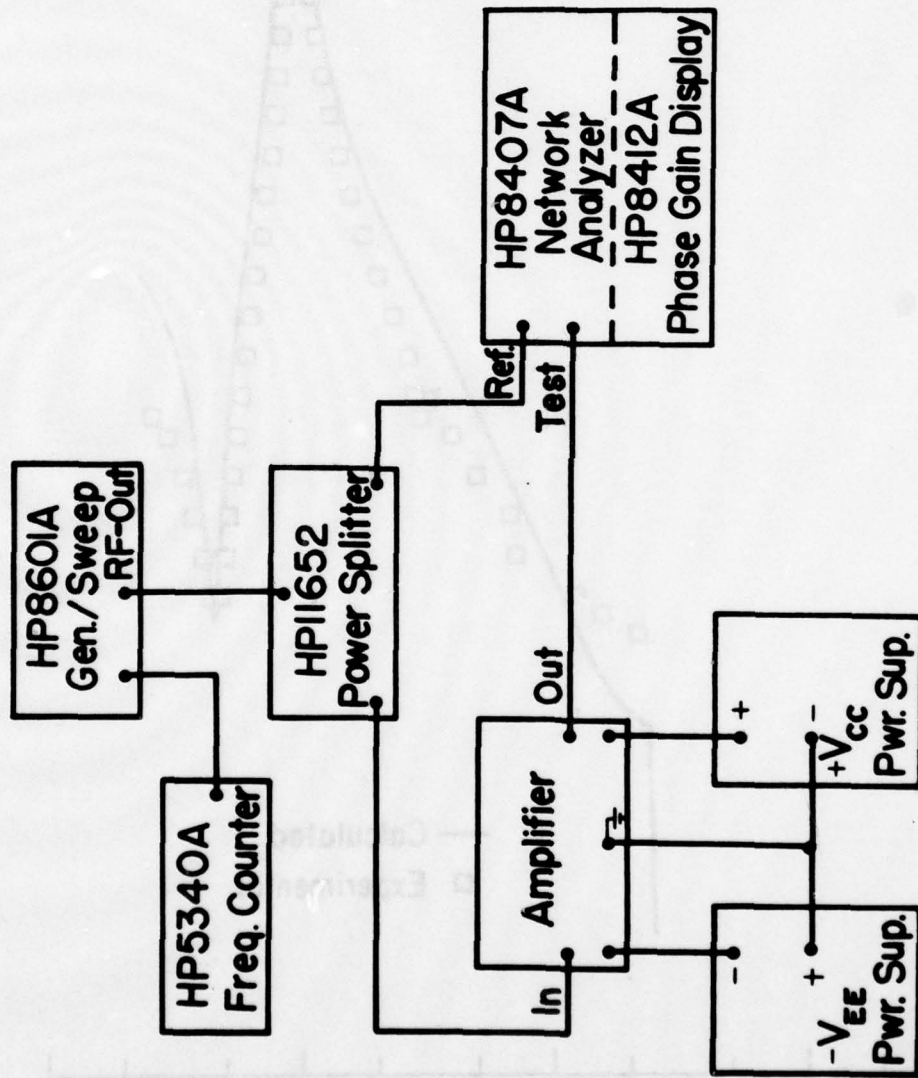

Fig. 6. Experimental System for Measuring Amplifier Linear Transfer Function V_{Test} / V_{Ref} in the HF/VHF Frequency Region

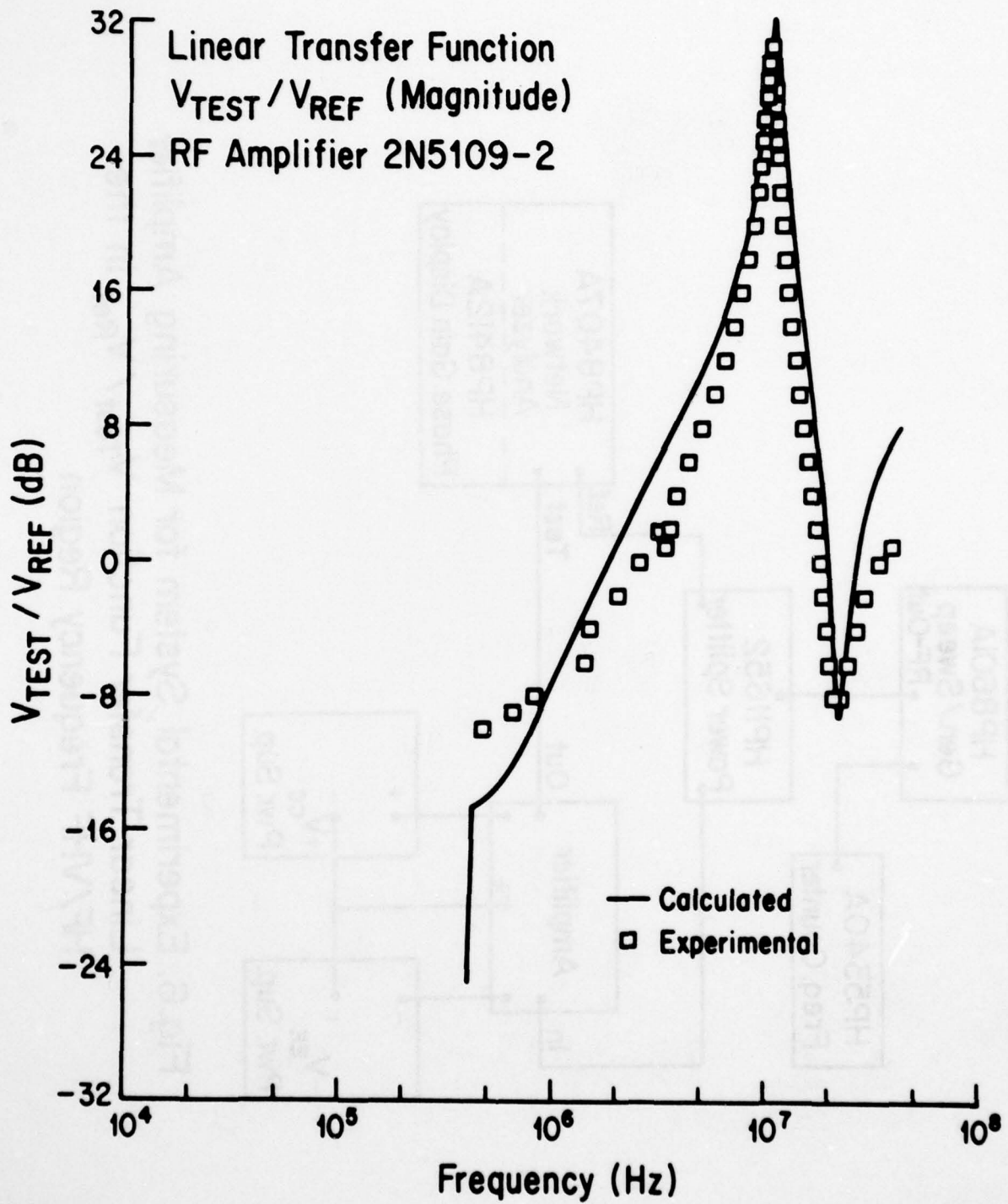

Fig. 7. Linear Transfer Function V_{TEST} / V_{REF} (Mag.)

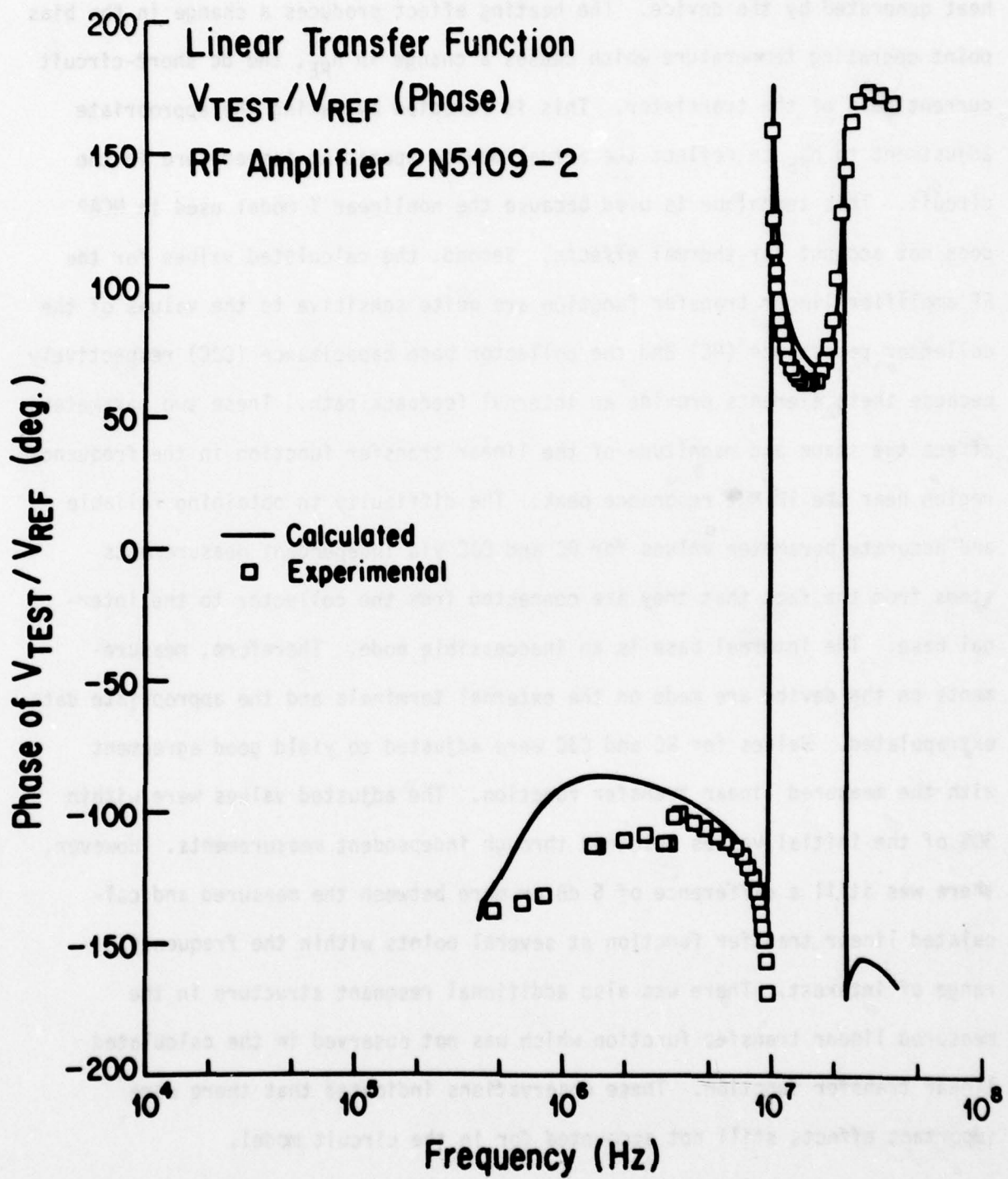

Fig. 8. Linear Transfer Function V_{TEST}/V_{REF} (Phase)

$V_C = 5 \text{ V}$ is not excessive for this device, there is a significant amount of heat generated by the device. The heating effect produces a change in the bias point operating temperature which causes a change in h_{FE} , the dc short-circuit current gain of the transistor. This is remedied by making the appropriate adjustment to h_{FE} to reflect the actual device operating temperature in the circuit. This technique is used because the nonlinear T model used in NCAP does not account for thermal effects. Second, the calculated values for the RF amplifier linear transfer function are quite sensitive to the values of the collector resistance (RC) and the collector base capacitance (CJC) respectively because these elements provide an internal feedback path. These two parameters affect the shape and magnitude of the linear transfer function in the frequency region near the 10 MHz resonance peak. The difficulty in obtaining reliable and accurate parameter values for RC and CJC via independent measurements stems from the fact that they are connected from the collector to the internal base. The internal base is an inaccessible node. Therefore, measurements on the device are made on the external terminals and the appropriate data extrapolated. Values for RC and CJC were adjusted to yield good agreement with the measured linear transfer function. The adjusted values were within 30% of the initial values obtained through independent measurements. However, there was still a difference of 5 dB or more between the measured and calculated linear transfer function at several points within the frequency range of interest. There was also additional resonant structure in the measured linear transfer function which was not observed in the calculated linear transfer function. These observations indicated that there were important effects still not accounted for in the circuit model.

Surprisingly, parasitic effects in discrete passive components are important factors in this frequency range (.1 to 20 MHz). A previous paper by Whalen and Paludi⁷ indicates which parasitic effects are important and how to obtain model parameter values. These techniques were implemented in this effort.

The improved linear model for the RF amplifier is illustrated in Fig. 9. The linear transfer function calculated by NCAP is plotted in Figs. 7 and 8. Relatively good agreement between the NCAP simulation and the measurement is obtained in the region of 10 MHz. A 2 dB to 4 dB difference in magnitude and a 5° to 40° difference in phase is observed at the lower and higher frequencies. The parasitic elements in the emitter path to ground, in addition to CJC and RC in the transistor model, affect significantly the magnitude of the gain in the 10 MHz region. The depth and width of the null at 20 MHz is controlled by the parasitic elements in the collector path to ground. Again, parameter values for the parasitic elements were adjusted to obtain relatively good agreement between NCAP calculations and measured data for the linear transfer function V_{TEST}/V_{REF} .

The results from this part of the investigation are used as input data in Su's computational techniques previously reported upon. Specifically, the procedure used to synthesize the compensating networks that reduce the RF amplifier third order IMP is based upon the model for the RF amplifier shown in Fig. 9. The compensating networks Y_1 and Y_3 shown schematically in Figs. 12 and 10 respectively were synthesized by K.L. Su.

Compensating network Y_3 is the primary network. It must provide two functions: (1) isolation so that the in-band response at 10 MHz is unaffected; (2) compensation so that the out-of-band responses at $f_2 - f_1 = 0.5$ MHz and

$2f_2 = 19.0$ MHz are modified properly.

Referring to Fig. 10, the parallel combination of L11 and C11 is tuned at 10 MHz to provide the isolation required at 10 MHz. An inductor L21 is added and adjusted for so that the series - parallel combination of L21 with L11 and C11 has a minimum impedance at 19 MHz. This is necessary so that the compensating network impedance at 19 MHz is not determined by the 10 MHz trap impedance but by the parallel combination of L3H and R3H. The parallel combination of L31 and C31 is tuned at 19 MHz. This trap blocks the 19 MHz signal and allows the compensating element R3L to act only upon the low frequency signal at 0.5 MHz. Conversely, the parallel combination of L41 and C41, tuned at 0.5 MHz, blocks the 0.5 MHz signal and allows the compensating elements L3H and R3H to act only upon the high frequency signal at 19 MHz. As in the case of the RF amplifier, a detailed linear model is required by NCAP. Using techniques developed by Whalen and Paludi⁷, a model for the compensating network Y_3 was developed. It is illustrated in Fig. 11. Similarly, the compensating network Y_1 was developed and modeled. The results are illustrated in Figs. 12 and 13. Briefly the compensating network Y_1 provides a low impedance at $2f_2 = 19$ MHz and a high impedance path at $f_2 - f_1 = 0.5$ MHz and $2f_2 - f_1 = 10$ MHz as well. Also added to the basic amplifier were emitter bypass networks tuned to provide low impedance paths at the frequencies $f_2 - f_1 = 0.5$ MHz and $2f_2 = 19$ MHz to reduce the effective impedance from emitter to ground. These are illustrated in Figs. 14 and 15. Without the emitter bypass networks the impedance Y_1 , because of parasitic effects, was thought to be too large at 0.5 and 19.0 MHz.

At this point, the linear modeling phase is complete. NCAP can use these data to compute higher order (particularly 2nd and 3rd) nonlinear

transfer functions. Figure 16 shows the composite model used for this analysis. Table II contains the results of such calculations. Note that NCAP predicts a 20 dB reduction in the third order IMP at $2f_2 - f_1 = 10$ MHz when the compensating networks are connected. No additional reduction was obtained by using the emitter bypass networks. Next the transfer functions will be measured and compared with those calculated by NCAP.

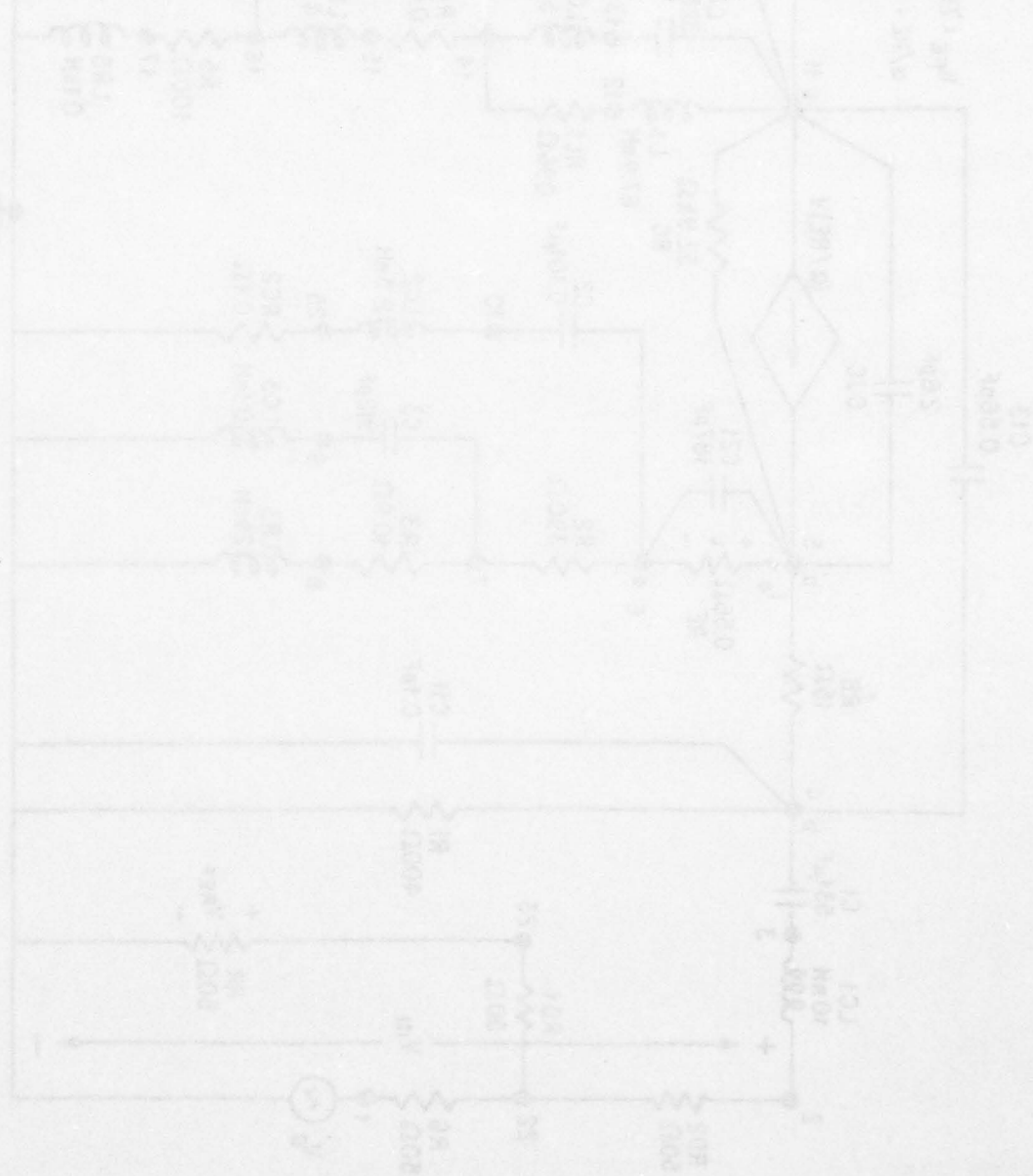

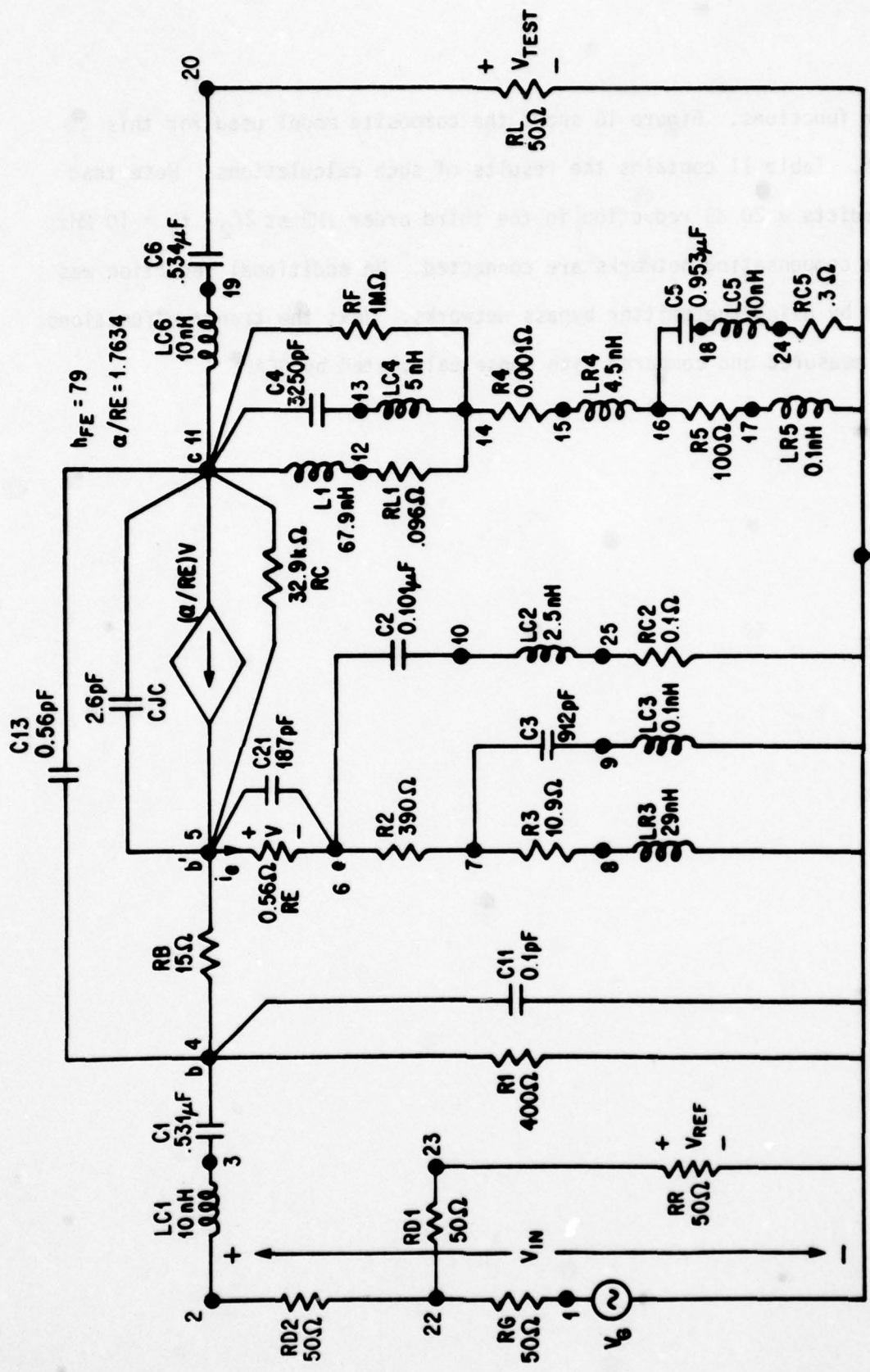

Fig. 9. HF/VHF Equivalent Circuit for the 2N5109-2 BJT RF Amplifier Used to Calculate the Linear Transfer Function V_{TEST}/V_{REF} .

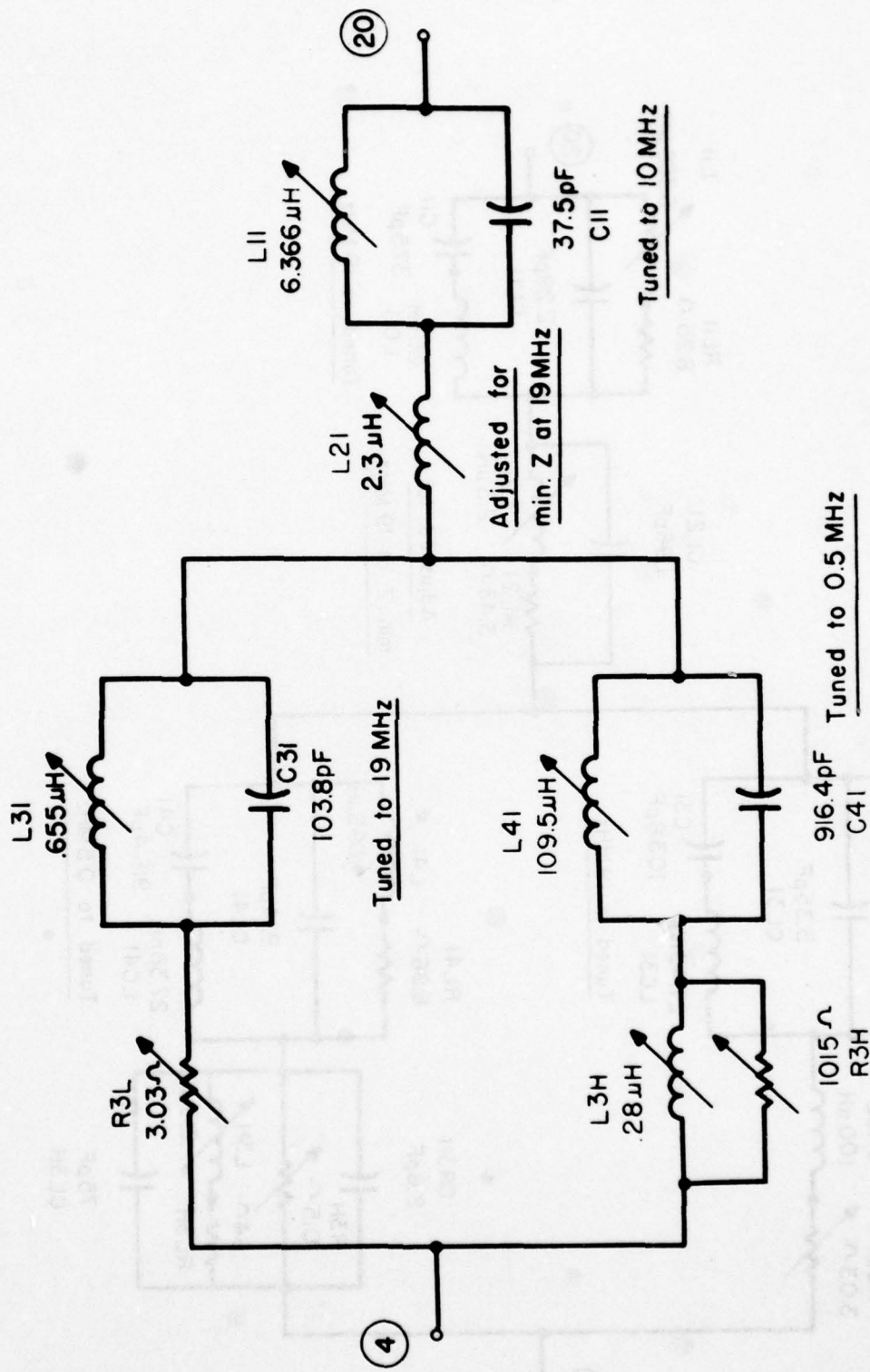

Figure 10. Schematic of Compensating Network Y_3

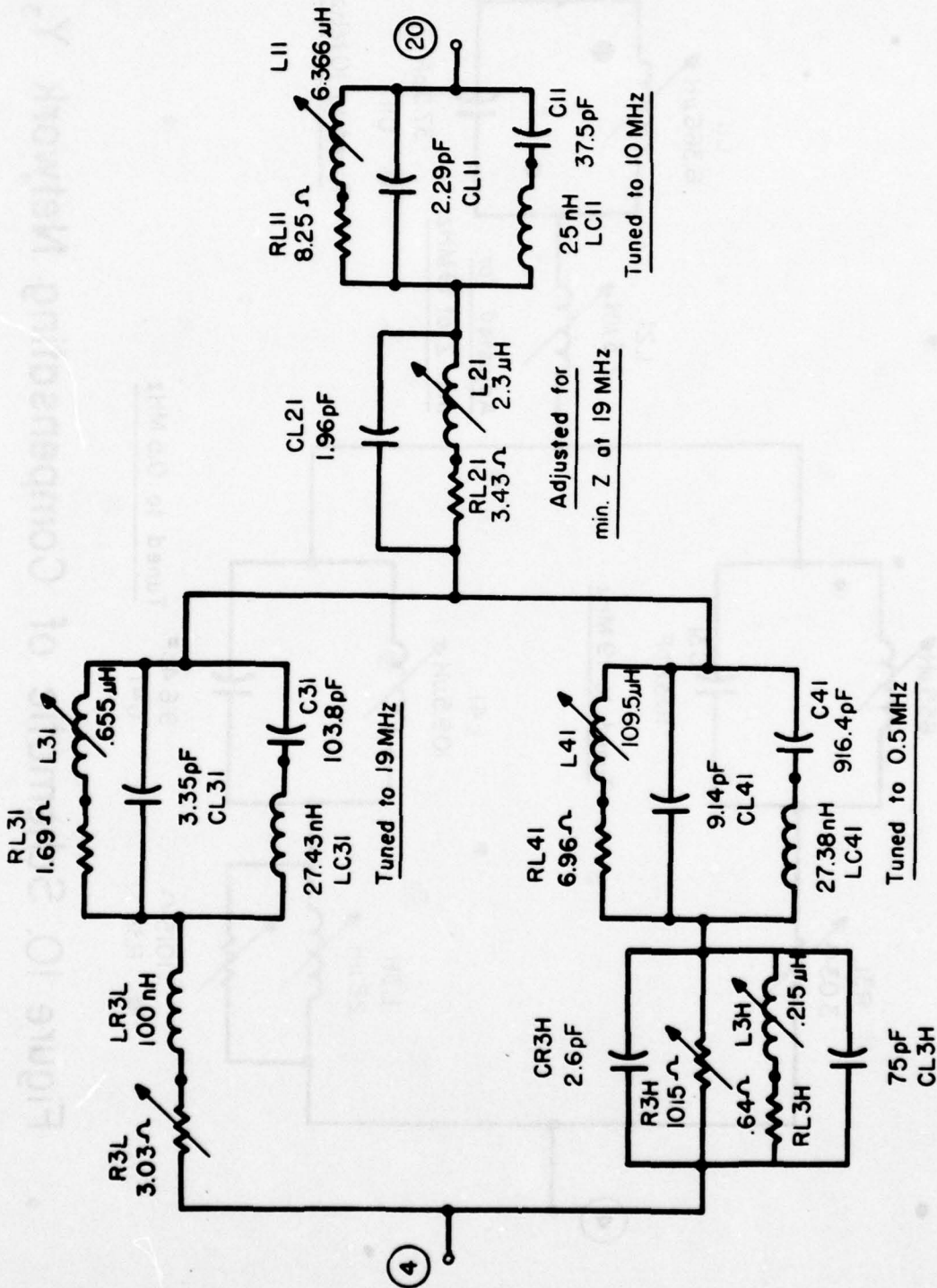

Figure 11. Model of Compensating Network Y_3

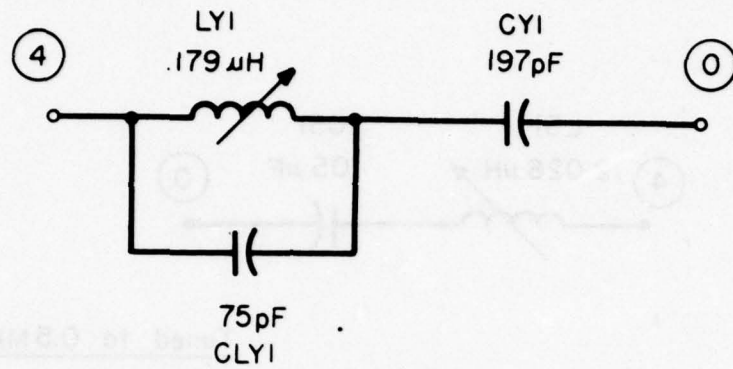

Figure 12. Schematic of Compensating Network Y_1

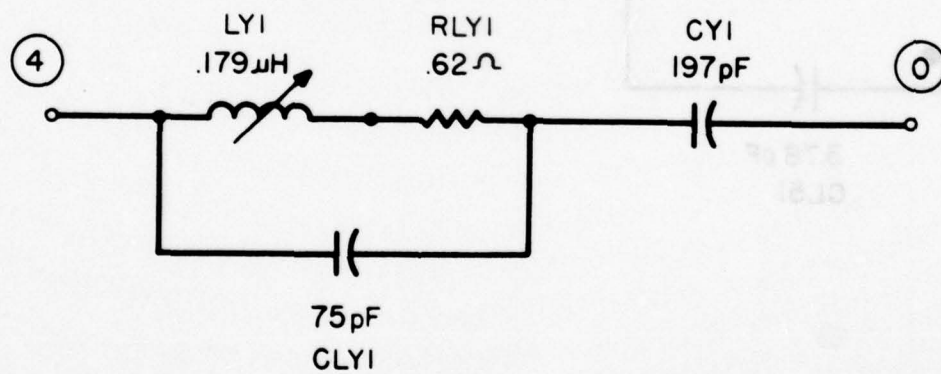

Figure 13. Model of Compensating Network Y_1

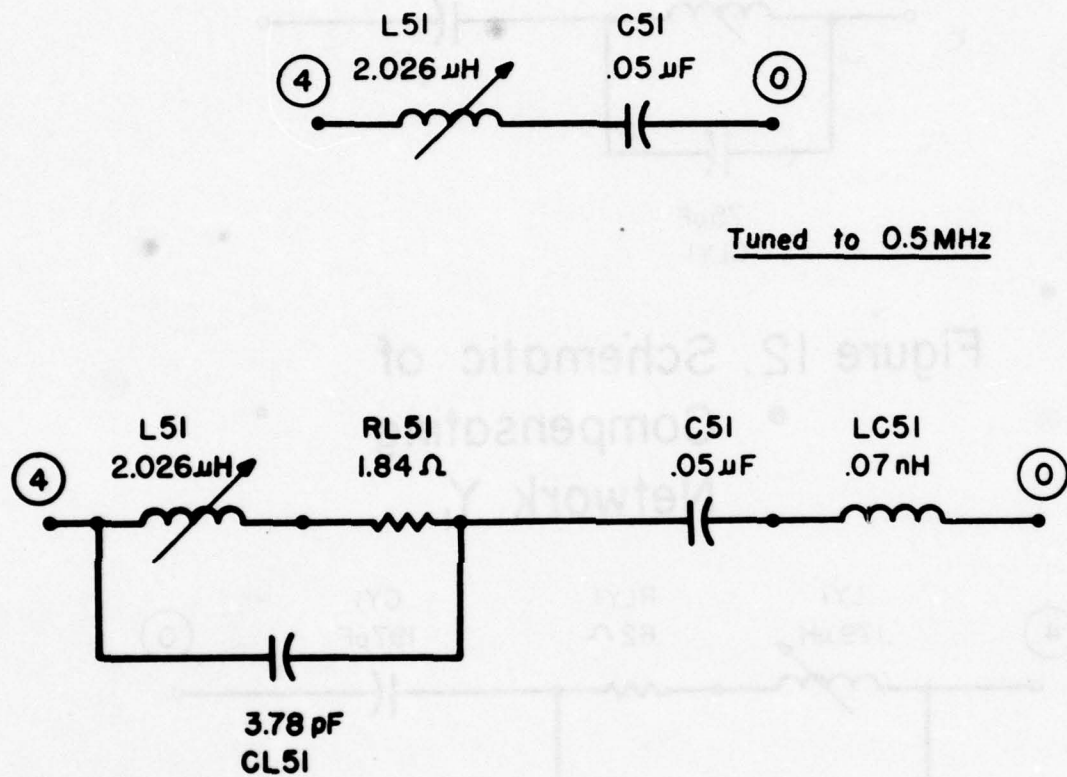

Fig. 14. Schematic and Model of Series L-C Tuned for Minimum Impedance at 0.5 MHz

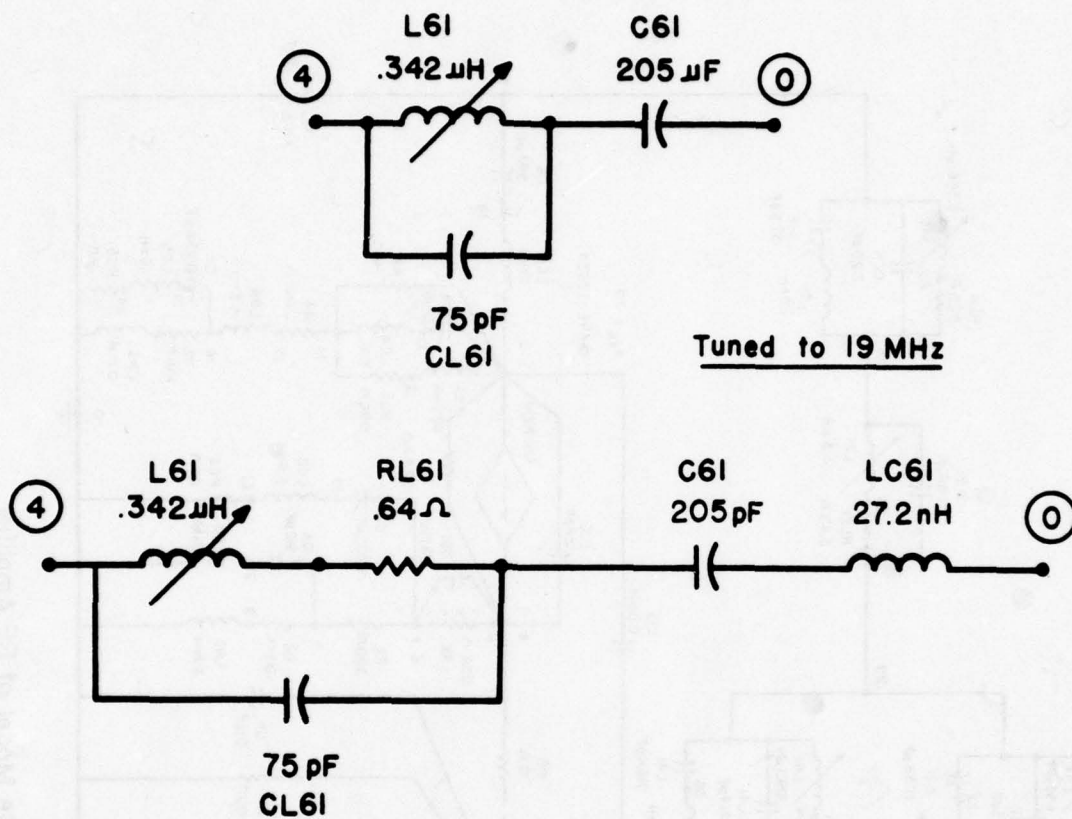

Fig. 15. Schematic and Model of Series LC Tuned for Minimum Impedance at 19 MHz

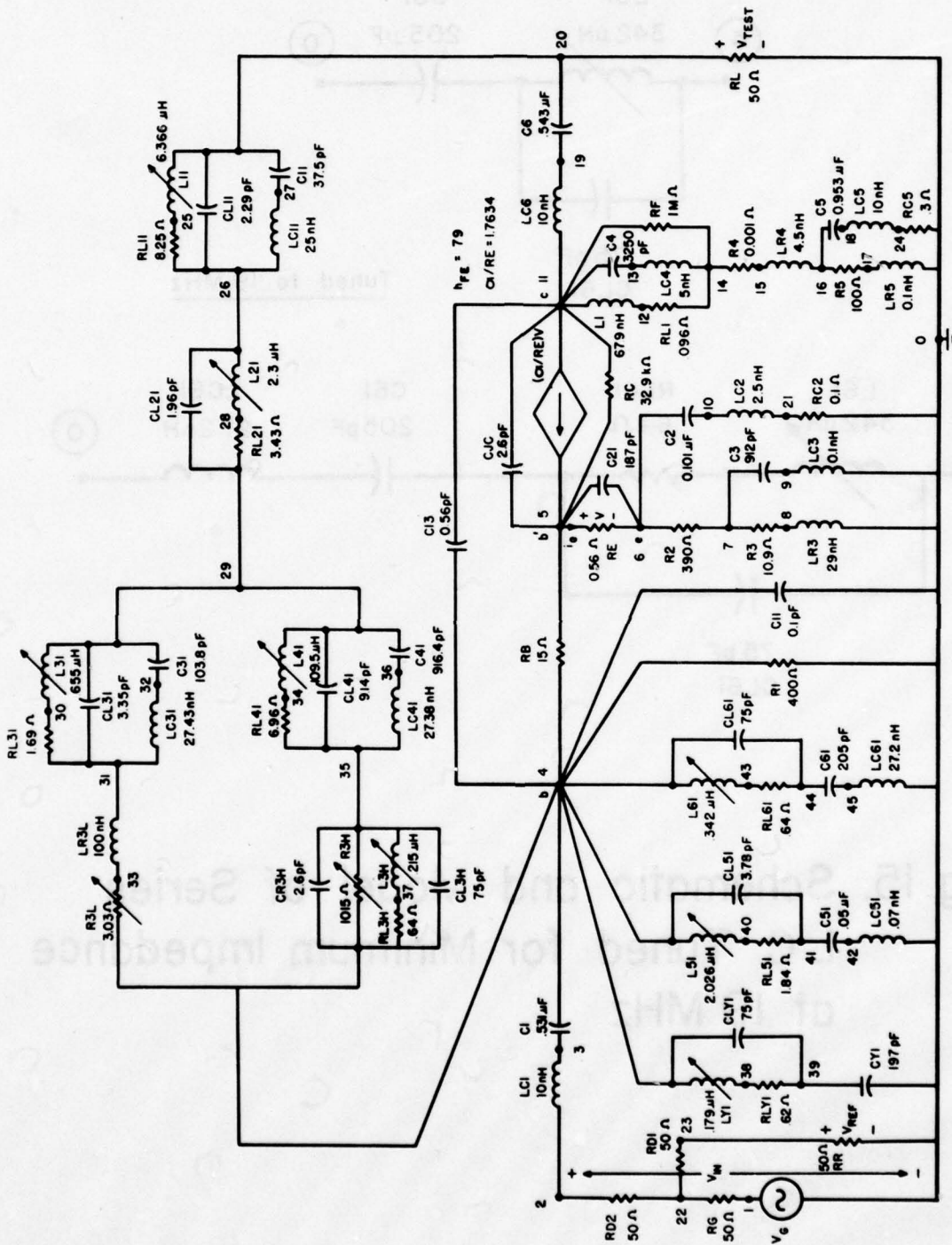

Fig. 16. Composite Model of RF Amplifier

TABLE II

NCAP CALCULATED NONLINEAR TRANSFER FUNCTIONS			
ORDER	COMBINATION	FREQ. MHz	TRANSFER FUNCTION
1	f_1	9.0	$H_1(f_1)$
1	f_2	9.5	$H_1(f_2)$
2	$f_2 - f_1$	0.5	$H_2(-f_1, f_2)$
2	$2f_1$	18.0	$H_2(f_1, f_1)$
2	$f_1 + f_2$	18.5	$H_2(f_1, f_2)$
2	$2f_2$	19.0	$H_2(f_2, f_2)$
3	$2f_1 - f_2$	8.5	$H_3(f_1, f_1, -f_2)$
3	$2f_2 - f_1$	10.0	$H_3(-f_1, f_2, f_2)$

NCAP CALCULATED TRANSFER FUNCTION VALUES WITH EMITTER BYPASS			
	BASIC AMPLIFIER ^a (dB)	WITH Y_1 & Y_3 (dB)	WITH EMITTER BYPASS ^c (dB)
	+19	+17	+17
	+22	+19	+19
	-18	-25	-23
	-01	-01	-01
	-02	-05	-05
	-04	+04	+04
	+39	+25	+24
	+48	+29	+28

- a The basic amplifier without compensating networks Y_1 and Y_3 and without emitter bypass networks.
- b The basic amplifier with compensating networks Y_1 and Y_3 but without the emitter bypass networks.
- c The basic amplifier with compensating networks Y_1 and Y_3 and with the emitter bypass networks (Figure 15).

SECTION 3

Experimental System and Procedures

In this section the experimental system and procedures used to measure the nonlinear transfer functions of the RF amplifier stage discussed in Section 2 will be described. Typical data will be shown. The essential equations which relate the output signals to the input signals via the nonlinear transfer functions will also be given.

To measure the RF amplifier nonlinear transfer functions a two tone measurement scheme was used⁵. As shown schematically in Fig. 17, CW sinusoidal signals at frequencies $f_1 = 9.0$ MHz and $f_2 = 9.5$ MHz were applied to the RF amplifier input. These two frequencies were selected to obtain a strong third order IMP at the frequency $2f_2 - f_1 = 10$ MHz. The resulting RF amplifier power spectrum was observed on a spectrum analyzer. A line drawing from a photograph of a typical spectrum analyzer display is shown in Fig. 18. The basic experimental system is quite simple. However, it is necessary to take several precautions in order to ensure that the higher order ($n = 2$ and $n = 3$) frequency terms observed on the spectrum analyzer display were a result of the RF amplifier nonlinearities and not a result of other nonlinearities. The precautions taken will be described briefly.

The RF signal generators used to produce the input signals with frequencies $f_1 = 9.0$ MHz and $f_2 = 9.5$ MHz also produce input signals at the harmonic frequencies $2f_1$, $2f_2$, $3f_1$, $3f_2$, etc. Rejection filters tuned to the frequencies $2f_1$, $2f_2$, $3f_1$ and $3f_2$ were inserted between the signal generators and the RF amplifier input in order to reduce these unwanted harmonics to a level 80 dB down from the level of the fundamental signals at frequencies

f_1 and f_2 . Effects related to the signal generator harmonics at $2f_1$, $2f_2$, $3f_1$ and $3f_2$ were made negligible by using these rejection filters.

Nonlinear responses can also be produced in the spectrum analyzer itself if any of the input signals to the spectrum analyzer exceed -40 dBm (the spectrum analyzer nonlinear responses are less than -110 dBm if the rms input signal is less than -40 dBm). The RF amplifier outputs at $f_1 = 9.0$ MHz and $f_2 = 9.5$ MHz did exceed -40 dBm. By inserting a rejection filter tuned to reject signals at the frequencies f_1 and f_2 between the RF amplifier output and the spectrum analyzer input, the level of all signals at the spectrum analyzer input can be kept below -40 dBm. The use of the rejection filter shown in Fig. 17 was necessary to make the spectrum analyzer behave as a linear receiver. It was verified that the spectrum analyzer behaved as a linear receiver by observing that a 10 dB change in the spectrum analyzer RF attenuator caused a 10 dB change in all signals displayed on the spectrum analyzer.

Additional checks were performed to verify that the measurement system was performing properly. The RF signal generator attenuators were changed by 5 dB and the resulting change in the signal levels displayed on the spectrum analyzer was observed. The expected relationships between the signal levels displayed on the spectrum analyzer and the input signal levels are given in Table III. Upon examining Table III it is observed that a RF amplifier output voltage amplitude at a frequency $rf_1 + sf_2$ is proportional to the product $(A_1^r) \cdot (A_2^s)$ where A_1 and A_2 are the RF Thevenin equivalent voltage amplitudes at the RF amplifier input.

A 5 dB change in the f_1 signal generator attenuator produces a 5 dB change in A_1 , a 10 dB change in A_1^2 , a 15 dB change in A_1^3 , etc. Thus the

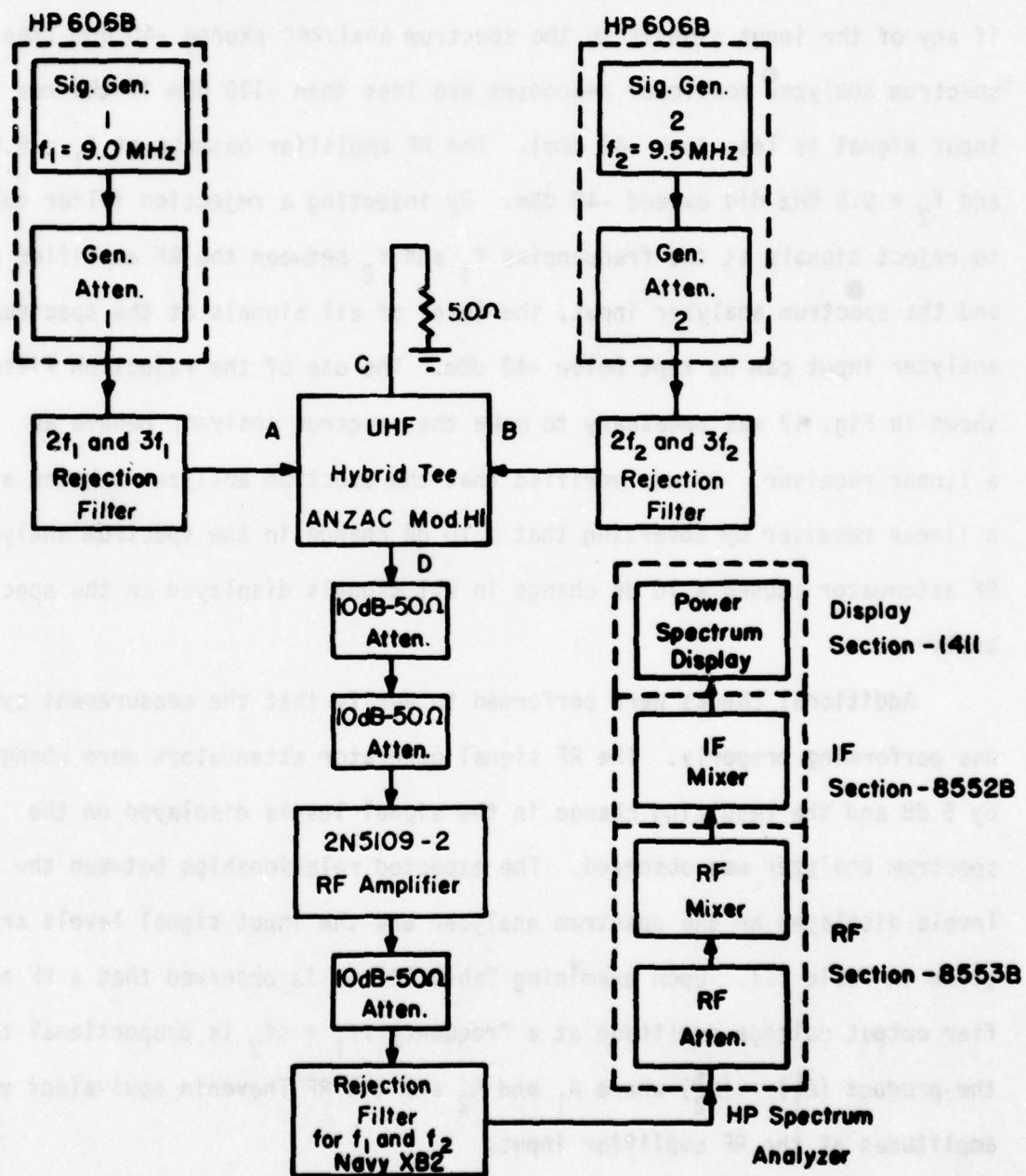

Fig. 17. Experimental System for Measuring $H_3(f_2, f_2, -f_1)$

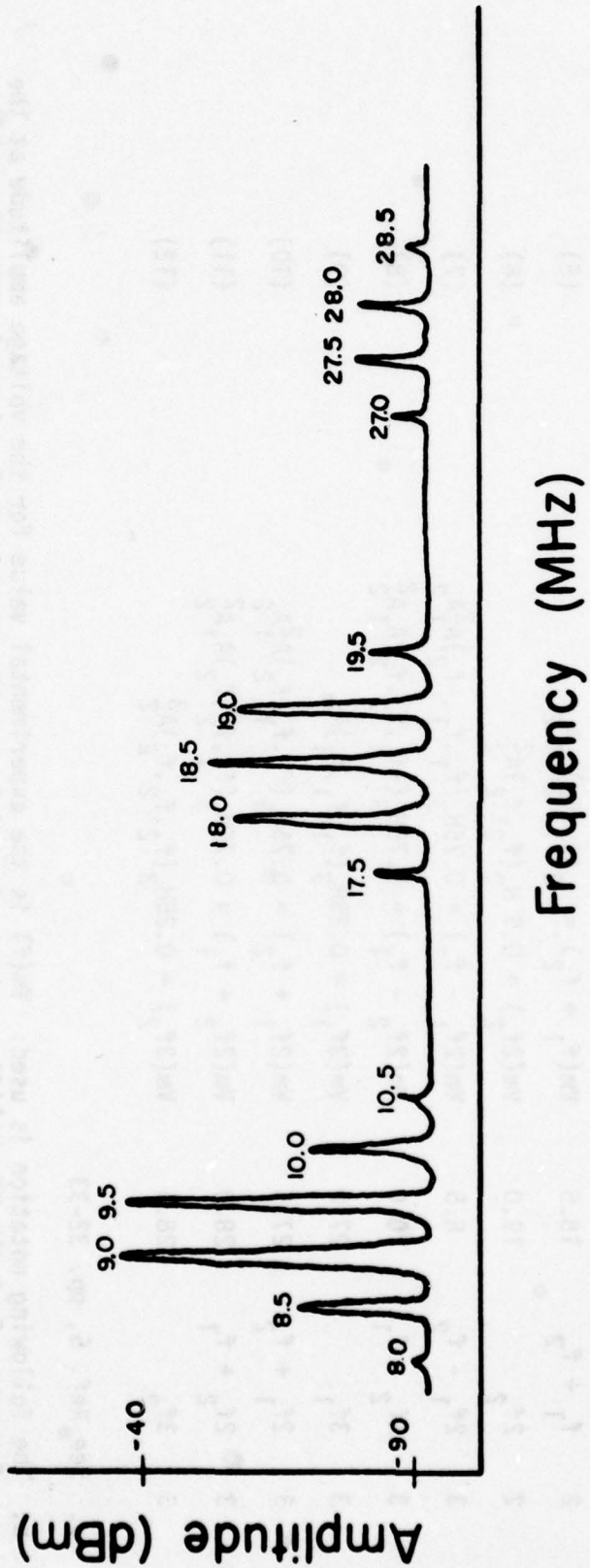

Fig. 18. Line Drawing of Photograph from Spectrum
Analyser Display of RF Amplifier Power
Density Spectrum

TABLE III

EQUATIONS RELATING EXPERIMENTAL RF AMPLIFIER INPUT AND OUTPUT VOLTAGES TO THE NONLINEAR TRANSFER FUNCTIONS FOR THE TWO TONE CASE^a

ORDER	FREQUENCY COMBINATION	FREQ. (MHZ)	EQUATION ^b	EQ. NO.
1	f_1	9.0	$V_m(f_1) = H_1(f_1)A_1$	(1)
1	f_2	9.5	$V_m(f_2) = H_1(f_2)A_2$	(2)
2	$f_2 - f_1$	0.5	$V_m(f_2 - f_1) = H_2(-f_1, f_2)A_1A_2$	(3)
2	$2f_1$	18.0	$V_m(2f_1) = 0.5H_2(f_1, f_1)A_1^2$	(4)
2	$f_1 + f_2$	18.5	$V_m(f_1 + f_2) = H_2(f_1, f_2)A_1A_2$	(5)
2	$2f_2$	19.0	$V_m(2f_2) = 0.5 H_2(f_2, f_2)A_2^2$	(6)
3	$2f_1 - f_2$	8.5	$V_m(2f_1 - f_2) = 0.75H_3(f_1, f_1, -f_2)A_1^2A_2$	(7)
3	$2f_2 - f_1$	10.0	$V_m(2f_2 - f_1) = 0.75H_3(-f_1, f_2, f_2)A_1A_2^2$	(8)
3	$3f_1$	27.0	$V_m(3f_1) = 0.25H_3(f_1, f_1, f_1)A_1^3$	(9)
3	$2f_1 + f_2$	27.5	$V_m(2f_1 + f_2) = 0.75H_3(f_1, f_1, f_2)A_1^2A_2$	(10)
3	$2f_2 + f_1$	28.0	$V_m(2f_2 + f_1) = 0.75H_3(f_1, f_2, f_2)A_1A_2^2$	(11)
3	$3f_2$	28.5	$V_m(3f_2) = 0.25H_3(f_2, f_2, f_2)A_2^3$	(12)

a. See Ref. 5, pp. 32-33

b. The following notation is used: $V_m(f)$ is the experimental value for the voltage amplitude at the frequency f at the RF amplifier output; A_1 and A_2 are the experimental values for the Thevenin equivalent voltage source amplitudes at the RF amplifier input

output voltages which depend upon A_1^2 (such as output signals at frequencies, $2f_1 - f_2$, $2f_1$, $2f_1 + f_2$) should change by 10 dB. The output voltages which depend upon A_1^3 (such as the output signal at the frequency $3f_1$) should change by 15 dB. Similar results should be obtained when the f_2 signal generator attenuator is changed by 5 dB. The output voltage levels which depend upon A_2 , A_2^2 , and A_2^3 should change by 5, 10, and 15 dB respectively. When the f_1 and f_2 signal generator attenuators were changed by ± 5 dB, the corresponding changes in the RF amplifier output as displayed on the spectrum analyzer were as expected within ± 1 dB. These checks established that the dominant nonlinearities were in the RF amplifier stage.

As discussed previously in Section I the main objective of this experimental investigation was to determine if the compensating networks Y1 and Y3 would cause a reduction in the 3rd order IMP at $2f_2 - f_1 = 10$ MHz. The compensating networks Y1 and Y3 were connected as shown in Fig. 3. The compensating networks contained several adjustable resistors and inductors. The values of the adjustable components were varied $\pm 25\%$ about the nominal (original) design value. No significant change in RF amplifier output voltage component at $2f_2 - f_1 = 10$ MHz was observed on the spectrum analyzer. Additional emitter bypass networks which were series resonant circuits tuned at $f_2 - f_1 = 0.5$ MHz and $2f_2 = 19$ MHz were connected from the emitter of the 2N5109 BJT to ground in order to improve the RF ground connection to the emitter at these frequencies. The combination of the emitter bypass networks and compensating networks did not produce a significant change in the 3rd order IMP at $2f_2 - f_1 = 10$ MHz. A discussion of the results observed will be given in Section V.

Using the equations given in Table III and the data contained in a spectrum analyzer display such as that shown in Fig. 18, the RF amplifier nonlinear transfer functions were determined. In Appendix A1, an example is presented to illustrate how values for the nonlinear transfer functions are determined so that the experimental values can be compared directly to values calculated using the computer program NCAP. In the next section a summary of experimental values and NCAP values for many of the RF amplifier nonlinear transfer functions will be given.

SECTION 4

Experimental and Calculated Values for the RF Amplifier Nonlinear Transfer Functions

In this section a comparison will be made between values for the RF amplifier nonlinear transfer functions measured in the laboratory and those calculated using the computer program NCAP. The experimental results were obtained using the procedures described in Section 3. The calculated results were obtained using the procedures described in Section 2. Results for four cases will be presented. The first two cases are the RF amplifier without the emitter bypass networks with and without the compensating networks. (As discussed in Section 2 the purpose of the emitter bypass networks is to provide a better RF ground connection at the frequencies $f_2 - f_1$ and $2f_2$ to the emitter terminal of the BJT in the RF amplifier.) The remaining two cases are the RF amplifier with the emitter bypass networks, with and without the compensating networks.

Given in Table IV are the experimental and calculated values for the RF amplifier nonlinear transfer functions when the emitter bypass networks are omitted. Results are presented for the basic amplifier without the compensating networks connected and with the compensating networks connected. Of particular interest to us are the experimental and calculated values for the 3rd order transfer function $H_3(-f_1, f_2, f_2)$ where $2f_2 - f_1 = 10$ MHz. These results are given by the bottom row of Table IV. First we note that the NCAP results for $H_3(-f_1, f_2, f_2)$ are +48 dB without the compensating networks and +29 dB with the compensating networks. Thus NCAP predicts a very significant 19 dB reduction in this 3rd order IMP when the compensating networks are connected. Next we note that the experimental results for $H_3(-f_1, f_2, f_2)$ are +39 dB without the compensating networks and +32 dB

TABLE IV

Experimental and Calculated Values for the RF Amplifier
Nonlinear Transfer Functions (Without Emitter Bypass Networks)

Order	Comb.	Freq. MHz	Transfer Function	Without Comp. Net. Exp. (dB)	With Comp. Net. Exp. (dB)	Without Comp. Net. NCAP (dB)	With Comp. Net. NCAP (dB)
1	f_1	9.0	$H_1(f_1)$	+18	+15	+19	+17
1	f_2	9.5	$H_1(f_2)$	+22	+18	+22	+19
2	$f_2 - f_1$	0.5	$H_2(-f_1, f_2)$	-10	-15	-18	-25
2	$2f_1$	18.0	$H_2(f_1, f_1)$	-02	-08	-01	-01
2	$f_1 + f_2$	18.5	$H_2(f_1, f_2)$	-04	-09	-02	-05
2	$2f_2$	19.0	$H_2(f_2, f_2)$	-04	-10	-04	+04
3	$2f_1 - f_2$	8.5	$H_3(f_1, f_1, -f_2)$	+29	+17	+39	+25
3	$2f_2 - f_1$	10.0	$H_3(-f_1, f_2, f_2)$	+39	+32	+48	+29

with the compensating networks. Thus the experiment yielded only a 7 dB reduction in this 3rd order IMP. Furthermore, as stated in Section 3, when the compensating network component values were varied (approximately $\pm 25\%$ about the original design values), no variation in the 3rd order IMP at $2f_2 - f_1 = 10$ MHz was observed. Therefore, the 7 dB reduction in 3rd order IMP observed experimentally is not claimed as evidence that the compensating networks performed as expected.

Upon examining Table IV an 8 to 10 dB discrepancy is seen to exist between the calculated and experimental values for the 2nd order transfer function $H_2(-f_1, f_2)$ at $f_2 - f_1 = 0.5$ MHz without (and with) the compensating networks. This discrepancy is believed to be significant because 2nd order transfer functions are important terms in a theoretical expression for one of the third order current generators, $I_{e3}(-f_1, f_2, f_2)$, which determines the output nonlinear transfer function $H_3(-f_1, f_2, f_2)$. Rewriting Eq. (3.11) from Su's report, the third order current generator $I_{e3}(-f_1, f_2, f_2)$ is given by

$$\begin{aligned}
 I_{e3}(-f_1, f_2, f_2) = & -2g_2/3 [V_{b1}(-f_1)V_{b2}(f_2, f_2) \\
 & + 2V_{b1}(f_2)V_{b2}(-f_1, f_2)] \\
 & - g_3V_{b1}(-f_1)V_{b1}^2(f_2)
 \end{aligned} \tag{4.1}$$

where g_2 and g_3 are coefficients related to the base-emitter nonlinearity, $V_{b1}(f_1)$ is the first order (linear) internal base node transfer function evaluated at the frequency f_1 , and $V_{b2}(f_1, f_j)$ the second order (nonlinear) internal base node transfer function evaluated at the frequency $f_1 + f_j$. The purpose of the compensating networks is to make the current generator $I_{e3}(-f_1, f_2, f_2)$ as small as possible by modifying the second order transfer functions $V_{b2}(f_2, f_2)$ and $V_{b2}(-f_1, f_2)$. The design of the compensating networks is based upon calculated

values for first order and second order transfer functions. The 8 to 10 dB discrepancy between experimental and calculated values for the output second order transfer function $H_2(-f_1, f_2)$ (without the compensating networks) indicates that the calculated value for the internal node second order transfer function $V_{b2}(-f_1, f_2)$ is in error also. The accuracy of the calculated values for $H_2(-f_1, f_2)$ and $H_2(f_2, f_2)$ depend upon several factors. This subject will be discussed in the next chapter.

Shown in Table V are the experimental and calculated results for the RF amplifier nonlinear transfer functions when the emitter bypass networks are included. Results are presented for the basic amplifier without the compensating networks connected and with the compensating networks connected.

One effect of the emitter bypass networks was to improve the agreement between the calculated value (-16 dB) and the experimental value (-13 dB) for $H_2(-f_1, f_2)$ for the RF amplifier without the compensating networks connected. As a result, the calculated values for the four transfer functions $H_1(f_1)$, $H_1(f_2)$, $H_2(-f_1, f_2)$ and $H_2(f_2, f_2)$ agree within 3 to 4 dB with the experimental values for the RF amplifier without the compensating networks connected.

Again NCAP predicts a 20 dB improvement in the 3rd order transfer function $H_3(-f_1, f_2, f_2)$ when the compensating networks are connected. However, the experiment yielded no significant change in this 3rd order IMP.

In the next section some probable causes for the observed experimental results will be given.

TABLE V

Experimental and Calculated Values for the RF Amplifier
Nonlinear Transfer Functions (With Emitter Bypass Networks)

Order	Comb.	Freq. MHz	Transfer Function	Without Comp. Net. Exp. (dB)	Without Comp. Net. NCAP (dB)	With Comp. Net. Exp. (dB)	With Comp. Net. NCAP (dB)
1	f_1	9.0	$H_1(f_1)$	+16	+19	+14	+17
1	f_2	9.5	$H_1(f_2)$	+19	+22	+19	+19
2	$f_2 - f_1$	0.5	$H_2(-f_1, f_2)$	-13	-16	-13	-23
2	$2f_1$	18.0	$H_2(f_1, f_2)$	-04	-00	-07	-01
2	$f_1 + f_2$	18.5	$H_2(f_1, f_2)$	-06	-02	-08	-05
2	$2f_2$	19.0	$H_2(f_2, f_2)$	-08	-04	-08	+04
3	$2f_1 - f_2$	8.5	$H_3(f_1, f_1, -f_2)$	+23	+38	+17	+24
3	$2f_2 - f_1$	10.0	$H_3(-f_1, f_2, f_2)$	+32	+48	+34	+28

SECTION 5
CONCLUSIONS

In this report we describe an experimental investigation to determine if a procedure previously reported upon for reducing third order IMP's in RF amplifier stages could be implemented in the laboratory.¹⁻⁴ The third-order IMP reduction procedure is based upon altering the RF amplifier linear out-of-band response by adding passive compensating networks. A RF amplifier stage tuned at 10 MHz was selected for the experiment. The RF amplifier was excited by two CW signals at frequencies $f_1 = 9.0$ MHz and $f_2 = 9.5$ MHz in order to obtain a third order IMP at the frequency $2f_2 - f_1 = 10$ MHz. The objective of the experiment was to determine if a significant reduction (more than 20 dB) in this third order IMP could be obtained by connecting properly designed compensating networks to the basic RF amplifier stage.

The most important step in the investigation and the one which required the most effort was to develop an accurate linear model for the basic RF amplifier stage over a frequency range $f_2 - f_1$ (0.5 MHz) to $2f_2$ (19 MHz). The linear model was developed by comparing measured and calculated values for the magnitude and phase of the basic RF amplifier linear (first order) transfer function V_{TEST}/V_{REF} . By accounting for some of the parasitic effects associated with the passive components (resistors, inductors, and capacitors), it was possible to develop a linear model for the basic RF amplifier that yielded calculated values for V_{TEST}/V_{REF} in fair agreement with the measured values. Over the frequency range $f_2 - f_1$ to $2f_2$ the largest deviation between calculated and measured values was 4 dB for the magnitude of V_{TEST}/V_{REF} and 40° for the phase of V_{TEST}/V_{REF} . It is interesting to note that the largest deviations between calculated and measured values for the magnitude

and phase of V_{TEST}/V_{REF} occurred near the frequency $f_2 - f_1 = 0.5$ MHz. An accurate linear model for the basic RF amplifier stage is needed for two reasons. One reason is that the Nonlinear Circuit Analysis Program NCAP used to calculate the RF amplifier third order IMP requires an accurate linear model in order to obtain accurate numerical results for the third order IMP. The second reason is that the synthesis procedure used to calculate values for the components used in the compensating networks depends critically upon the accuracy of the linear model developed for the basic RF amplifier stage.

Using the linear model for the basic RF amplifier described in Section 2, compensating networks were synthesized. When the compensating networks were connected to the basic RF amplifier stage the computer program NCAP predicted that a 20 dB reduction would result in the value for the third order IMP at $2f_2 - f_1 = 10$ MHz. When the compensating networks were connected to the basic RF amplifier stage in the laboratory, little (if any) reduction in the third order IMP at $2f_2 - f_1 = 10$ MHz was observed experimentally. The important compensating network component values were varied approximately $\pm 25\%$ about the nominal design values. Again no significant reduction in the third order IMP at $2f_2 - f_1 = 10$ MHz was observed experimentally.

The main reason why the third order IMP reduction scheme investigated did not yield the 20 dB reduction predicted by NCAP appears to be that the synthesis procedure used to determine the compensating network component values depends critically upon the accuracy of the linear model developed for the basic RF amplifier stage. Although the linear model developed is sufficiently accurate to determine linear (first order) and nonlinear (second, third, and higher order) transfer functions of the RF amplifier for most purposes, it is not accurate enough to be a basis for synthesizing compen-

sating network component values. An estimate of the accuracy required can be obtained by viewing the third order IMP reduction scheme as a cancellation scheme in which the compensating networks produce a signal V_{CN} at the third order frequency $2f_2 - f_1$ which cancels a basic amplifier signal V_{BA} at that frequency. To obtain a 20 dB reduction, the difference $V_{BA} - V_{CN}$ must be $0.1 \times V_{BA}$. Thus the signal V_{CN} must match the signal V_{BA} in amplitude with $\pm 10\%$ (0.9 dB) and in phase $\pm 6^\circ$. The requirements on the accuracy required for the first order (linear) transfer function appear to be three times as stringent as that required for the third order signals V_{BA} and V_{CN} . This suggests that a linear model for the basic amplifier stage must be developed that predicts the basic amplifier magnitude response within ± 0.3 dB and phase response within $\pm 2^\circ$ over the frequency range $f_2 - f_1$ to $2f_2$. If these estimates on the accuracy requirements for the linear model are correct, then either our modeling capability must be improved significantly or an alternate procedure for synthesizing the component values in the compensating network must be devised.

A procedure for synthesizing the compensating network component values which was based directly upon experimental values for the basic amplifier transfer functions would be very useful. The need to develop an accurate linear model for the basic amplifier stage would be eliminated. This alternate approach is suggested by a procedure used to predict the stability of feedback amplifiers. The measured amplitude and phase responses of the basic amplifier and the feedback network can be used to predict the stability of the amplifier and feedback network combination. Although it is not obvious how a compensating network synthesis procedure based upon measured transfer functions could actually be developed, if such a procedure could be developed

it would appear to be useful not only for single-stage RF amplifiers but also for multi-stage RF amplifiers.

If the design of the compensating networks must be based upon a linear model for the basic RF amplifier, then a significant increase in model accuracy appears required. In particular a significant improvement in models for the passive components such as resistors, capacitors, and inductors in the basic RF amplifier stage must be achieved.⁷ The parasitic elements such as lead inductance, fringing capacitance, and series and/or shunt resistance must be modeled carefully and accurately over the broad frequency range $f_2 - f_1$ to $2f_2$. (This frequency range will typically be five or more octaves.) An effort to develop models for passive components that accurately account for parasitic effects in the range 1 MHz to 1 GHz is planned. In addition it may also be necessary to model Printed Circuit Board (PCB) wiring effects such as distributed capacitance and inductance in a two wire system and mutual capacitances and inductances in a multi-wire system. For example, in a two-wire system the delay between signal output and input is approximately .05 nsec/cm which causes a phase lag of $0.018^\circ/\text{cm}/\text{MHz}$. The phase delay in a PCB path 30 cm long (which corresponds to the path length of the compensating network) at 20 MHz would be 10.8° which appears to be significant. Extensive studies on the mutual capacitances and inductances of multi-conductor systems have been carried out and reported upon by Paul.¹² These results should be put into a form suitable for use with the Nonlinear Circuit Analysis Program NCAP. Both lumped circuit models and transmission line models are needed. An effort to develop such models is planned. When improved modeling techniques have been developed that account accurately for parasitic effects in passive components over the frequency range 1 to 1000 MHz and for the distributed effects associated with multi-conductor PCB

wiring, it would be appropriate to synthesize new passive compensating networks that reduce third order IMP's in the RF amplifier stage and to make another attempt to determine how well the new networks perform experimentally.

APPENDIX A1

Determining Experimental Values for the RF Amplifier Nonlinear Transfer Functions

In this appendix an example will be presented to demonstrate how experimental values for the RF amplifier nonlinear transfer functions are determined so that the experimental values can be compared directly to the values calculated by the computer program NCAP. As an example, the experimental value for $H_3(-f_1, f_2, f_2)$ will be calculated. The computer program NCAP calculates nonlinear transfer function values for the simplified circuit shown in Fig. A1.

Upon comparing Fig. A1 to the schematic of the experimental system shown in Fig. 17, it is observed that the attenuators and rejection filters between the RF amplifier output and the spectrum analyzer output are omitted in the NCAP analysis. The insertion loss $L_0(f)$ of the attenuators and rejection filter between RF amplifier output and spectrum analyzer input was measured at each frequency f of interest. For example, at the 3rd order IMP frequency $2f_2 - f_1 = 10$ MHz, the L_0 value was 35 dB. The L_0 value is added to the spectrum analyzer power reading (-71 dBm at 10 MHz) to obtain the RF power P_0 (-36 dBm at 10 MHz) that would be delivered to a 50 ohm load resistor at the RF amplifier output. Using the expression $P_0 = V_m^2/2R_L$, a value for the RF amplifier output voltage V_m (-46 dBV at 10 MHz) was determined. Next, values for the RF amplifier Thevenin equivalent source amplitudes A_1 and A_2 were determined by connecting the RF amplifier input signal cable directly to the spectrum analyzer which had a 50 ohm input impedance. The input power $P_1(f_1)$ and $P_1(f_2)$ were measured. The input voltage amplitudes A_1 and A_2 were calculated using the expressions $P_1(f_1) = A_1^2/8R_s$ and $P_1(f_2) = A_2^2/8R_s$ where $R_s = 50$ ohms. The values measured were $P_1 = -22$ dBm at $f_1 = 9.0$ MHz and $f_2 = 9.5$ MHz. The

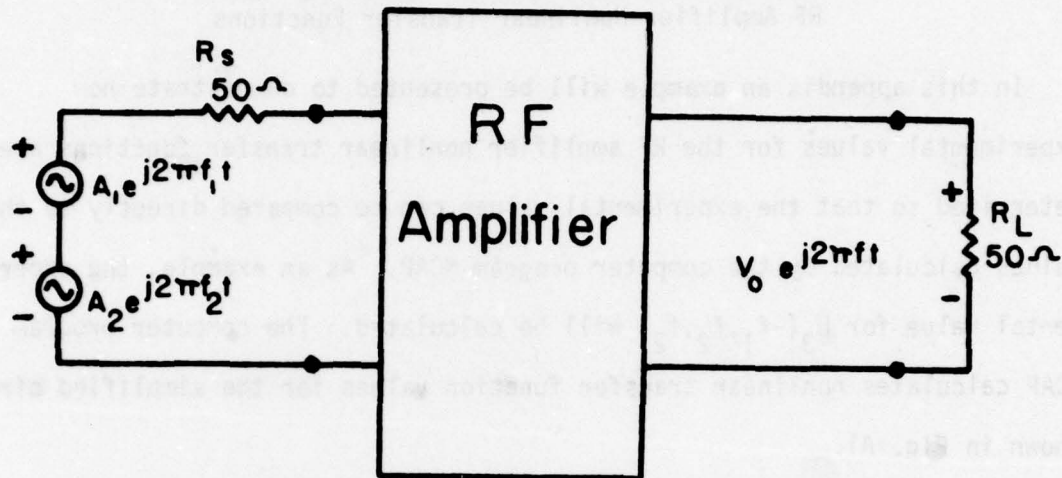

Fig. A1. Basic Circuit Configuration
 Analyzed by the Computer Program
 NCAP. The Frequency $f = rf_1 + sf_2$ where
 r and s take on integer values $0, 1, 2, 3, \dots$

values calculated for A_1 and A_2 were -26 dBV.

Next the nonlinear transfer function of interest is calculated using the appropriate equation from Table III in Section 3. Since in this example the nonlinear transfer function $H_3(-f_1, f_2, f_2)$ is being calculated, Equation (8) of Table III is re-written as

$$20 \log_{10} H_3 (-f_1, f_2, f_2) = 20 \log_{10} V_m (2f_2 - f_1) - 20 \log_{10} (3/4) - 20 \log_{10} A_1 - 40 \log_{10} A_2 \quad (\text{A.1})$$

Using $V_m (2f_2 - f_1) = -46$ dBV and $A_1 (f_1) = A_2 (f_2) = -26$ dBV, a value $H_3 (-f_1, f_2, f_2) = +34.5$ dB was obtained. Values for the other nonlinear transfer functions were calculated in a similar manner.

REFERENCES

1. K. L. Su, D. D. Weiner, and J. F. Spina, "Reduction of in-band nonlinear effects in electronic systems through the design of out-of-band linear response," Proceedings 1975 IEEE International Symposium on Circuits and Systems, pp. 293-296, Boston, Massachusetts, April 1975.
2. J. F. Spina, K. L. Su, and D. D. Weiner, "Reduction of circuit intermodulation distortion via the design of linear out-of-band behavior," 1975 IEEE Electromagnetic Compatibility Symposium Record, pp. 6B1g 1-4, San Antonio, Texas, October 1975.
3. K. L. Su, "Reduction of in-band nonlinear effects in electronic systems through the design of out-of-band linear response" Technical Report RADC-TR-75-30, Rome Air Development Center, Griffiss Air Force Base, New York, February 1975. (AD A007777).
4. K. L. Su, "Computational techniques for the reduction of nonlinear effects using passive compensating networks," Technical Report RADC-TR-76-369, Rome Air Development Center, Griffiss Air Force Base, New York, December 1976. (AD A035 855).
5. J. W. Graham and L. Ehrman, "Nonlinear system modeling and analysis with application to communications receivers," Technical Report RADC-TR-73-178, Rome Air Development Center, Griffiss Air Force Base, New York, June 1973. (AD 766 278)
6. J. J. Whalen, C. A. Paludi, Jr., and T. F. Fang, "Applications of the Nonlinear Circuit Analysis Program NCAP," 1977 IEEE International Electromagnetic Compatibility Symposium Record, pp. 467-474, Seattle, Washington, August 1977. (IEEE Pub. No. 77OH 1231-0 EMC)
7. J. J. Whalen and C. A. Paludi, Jr., "Computer-aided analysis of electronic circuits - the need to include parasitic elements," International Journal of Electronics, Vol. 43, pp. 501 - 511, Nov. 1977.
8. J. F. Spina, J. Lexa, and D. D. Weiner, "Computer modeling of a solid state VHF tuner using the nonlinear transfer function approach," Technical Memorandum, Rome Air Development Center, Griffiss Air Force Base, New York, 1974.
9. J. B. Valente, "The Nonlinear Circuit Analysis Program NCAP," 1977 IEEE International Electromagnetic Compatibility Symposium Record, pp. 461-466, Seattle, Washington, August 1977. (IEEE Pub. No. 77OH 1231-0 EMC)
10. J. C. Bowers and S. R. Sedore, "SCEPTRE: A Computer Program for Circuit and System Analysis," pp. 111 - 153. New Jersey: Prentice Hall, 1971.

11. J. Valente et al., "NCAP User's Manual" Rome Air Development Center, Griffiss Air Force Base, New York. (in preparation)

12. C. R. Paul, "Applications of multiconductor transmission line theory to the prediction of cable coupling," Volumes 1,2,3, and 7, Technical Report RADC-TR-76-101, Rome Air Development Center, Griffiss Air Force Base, New York, April 1976 (Vols. 1 and 2), February 1977 (Vol. 3), and July 1977 (Vol. 7). (Vol I - A025028) (Vol II - A025029) (Vol III - A038316)

Setting responses are considered. ...
for $\frac{1}{2}(\frac{1}{2}, \frac{1}{2}, \frac{1}{2})$ are 420 on without the comparison objects and 415 on

