

AD-A072 482

NAVAL AIR DEVELOPMENT CENTER WARMINSTER PA AIRCRAFT --ETC F/G 5/9  
APPLICATION AND EVALUATION OF FULLY PROCEDURALIZED JOB PERFORMA--ETC(U)  
DEC 78 C J THEISEN, T J ELLIOTT

UNCLASSIFIED

NADC-78286-60

NL

1 OF 2  
ADA  
072482



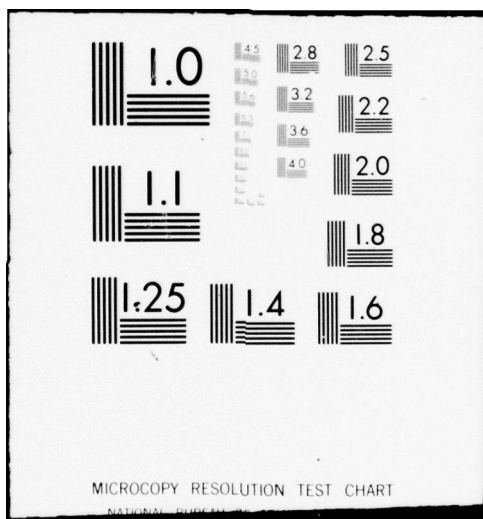

MICROCOPY RESOLUTION TEST CHART

NATIONAL BUREAU OF STANDARDS-1963-A

**LEVEL**

REPORT NO. NADC-78286-60

12



DDC  
RECEIVED  
AUG 7 1979  
C

AD A 072482

APPLICATION AND EVALUATION  
OF  
FULLY PROCEDURALIZED JOB PERFORMANCE AIDS  
AND  
TASK ORIENTED TRAINING TECHNOLOGIES

Charles J. Theisen, CDR, USN  
NAVAL AIR DEVELOPMENT CENTER  
Warminster, Pennsylvania 18974

(Commanding Officer, Naval Hospital Corps School, Great Lakes, Illinois)

Thomas K. Elliott  
APPLIED SCIENCE ASSOCIATES  
Valencia, Pennsylvania 16059

Robert P. Fishburne, Jr., LT, MSC, USNR  
NAVAL TECHNICAL TRAINING COMMAND  
Naval Air Station Memphis (75)  
Millington, Tennessee 38054

1 DECEMBER 1978

FINAL REPORT  
AIRTASK NO. A4134133/300/1413500001

APPROVED FOR PUBLIC RELEASE; DISTRIBUTION UNLIMITED.

Prepared for  
NAVAL AIR SYSTEMS COMMAND  
Department of the Navy  
Washington, D.C. 20361

DDC FILE COPY

79 08 06 037

## NOTICES

**REPORT NUMBERING SYSTEM** - The numbering of technical project reports issued by the Naval Air Development Center is arranged for specific identification purposes. Each number consists of the Center acronym, the calendar year in which the number was assigned, the sequence number of the report within the specific calendar year, and the official 2-digit correspondence code of the Command Office or the Functional Directorate responsible for the report. For example: Report No. NADC-78015-20 indicates the fifteenth Center report for the year 1978, and prepared by the Systems Directorate. The numerical codes are as follows:

CODE	OFFICE OR DIRECTORATE
00	Commander, Naval Air Development Center
01	Technical Director, Naval Air Development Center
02	Comptroller
10	Directorate Command Projects
20	Systems Directorate
30	Sensors & Avionics Technology Directorate
40	Communication & Navigation Technology Directorate
50	Software Computer Directorate
60	Aircraft & Crew Systems Technology Directorate
70	Planning Assessment Resources
80	Engineering Support Group

**PRODUCT ENDORSEMENT** - The discussion or instructions concerning commercial products herein do not constitute an endorsement by the Government nor do they convey or imply the license or right to use such products.

APPROVED BY:

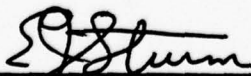

E. J. STURM  
CDR USN

DATE:

6/26/79

UNCLASSIFIED

SECURITY CLASSIFICATION OF THIS PAGE (When Data Entered)

REPORT DOCUMENTATION PAGE		READ INSTRUCTIONS BEFORE COMPLETING FORM
1. REPORT NUMBER NADC-78286-60	2. GOVT ACCESSION NO.	3. RECIPIENT'S CATALOG NUMBER
4. TITLE (and Subtitle) APPLICATION AND EVALUATION OF FULLY PROCEDURAL- IZED JOB PERFORMANCE AIDS AND TASK ORIENTED TRAINING TECHNOLOGIES		5. TYPE OF REPORT & PERIOD COVERED Final Report
7. AUTHOR(s) Charles J. Theisen, Thomas J. Elliott Robert P. Fishburne, Jr.		6. PERFORMING ORG. REPORT NUMBER
9. PERFORMING ORGANIZATION NAME AND ADDRESS Naval Air Development Center Warminster, PA 18974 ATTN: CODE 602		8. CONTRACT OR GRANT NUMBER(s)
11. CONTROLLING OFFICE NAME AND ADDRESS Naval Air Systems Command Department of the Navy Washington, DC 20361		10. PROGRAM ELEMENT, PROJECT, TASK AREA & WORK UNIT NUMBERS AIRTASK NO. A4134133/300/ 14125000001
14. MONITORING AGENCY NAME & ADDRESS (if different from Controlling Office) 120 124 p.		12. REPORT DATE 1 December 1978
		13. NUMBER OF PAGES 120
		15. SECURITY CLASS. (of this report) UNCLASSIFIED
		15a. DECLASSIFICATION/DOWNGRADING SCHEDULE
16. DISTRIBUTION STATEMENT (of this Report)  APPROVED FOR PUBLIC RELEASE; DISTRIBUTION UNLIMITED.		
17. DISTRIBUTION STATEMENT (of the abstract entered in Block 20, if different from Report)		
18. SUPPLEMENTARY NOTES		
19. KEY WORDS (Continue on reverse side if necessary and identify by block number) Life Cycle Costs      Head/Book Trade Off      Technical Data Presentation Job and Task Analyses      Aptitude Tests      Maintenance Effectiveness Technical Training      Personnel Selection      Costs of Ownership of Hardware Maintenance Training      Human Subsystems      Technical Training Directives Job Oriented Training      Job Performance Aids      Vocational Education Objectives		
20. ABSTRACT (Continue on reverse side if necessary and identify by block number) This report concerns the effectiveness of a combined application of the Fully Proceduralized Job Performance Aid (FPJPA) and Job Oriented Training (JOT) technologies for Navy maintenance personnel with medium electronic aptitudes. FPJPAs were developed for the AN/AQA 7 Sonar Signal Processing System, a system installed in the S2G and P-3 series aircraft. These FPJPAs were developed in keeping with the draft specification and guidance documents of AFHRI-TR-71-53 (I, II, III, AD-740 903, AD-744 044 and AD-744 817) for		

DD FORM 1 JAN 73 1473

EDITION OF 1 NOV 68 IS OBSOLETE  
S/N 0102-LF-014-6601

393 532  
SECURITY CLASSIFICATION OF THIS PAGE (When Data Entered)  
79 08 06 038

19. Task Oriented Training
  - Human Factors in Life Cycle Costs
  - Fully Proceduralized Maintenance Technical Data
  - Fully Proceduralized Performance Aids (FPJPA)
  - Training/Job Performance Aid Trade-Off
  - Job Guide Manuals (JGM)
  - Job Performance Manuals (JPM)
  - Fully Proceduralized Troubleshooting Aids (FPTA)
  - Improved Maintenance Guidance Information (IMG&I)

20. Both non-troubleshooting (non-TS) and troubleshooting (TS) tasks, for both organizational (O) and intermediate (I) levels of maintenance. Two Job Oriented Training (JOT) programmed packages were also developed to support these FPJPAs - a 13-week program for "O" level subjects and a 16-week program for "I" level subjects. These JOT programs were substantially shorter than entry training with for "O" level maintenance was 24 weeks and for "I" level maintenance 36 weeks. These traditional electronic maintenance programs are successfully completed only by personnel of very high aptitude. The "O" level JOT program was administered to one group of 15 medium aptitude subjects and the "I" level program to two groups of 13 medium aptitude subjects. These were less than ideal administrations due to late delivery of JOT materials and to too few instructors and equipments. Following these training programs, these subjects were required to perform representative maintenance tasks using FPJPAs. These medium aptitude "O" level subjects solved 86.6 percent of their TS problems and the "I" level subjects solved 89.1 percent of their TS problems. Although Navy control data were not obtained for this evaluative tryout, the performance of these medium aptitude inexperienced Navy subjects using FPJPAs compared favorably with the performance of high aptitude inexperienced Air Force subjects also using FPJPAs of a similar Air Force study. These medium aptitude Navy subjects using FPJPAs performed TS substantially better than did high aptitude experienced Air Force technicians using traditional maintenance manuals (TMM). These high aptitude Air Force experienced technicians had received 36 weeks of formal theory based training and required several months of on-the-job training to become job proficient. This evaluative tryout demonstrated the feasibility of combining the FPJPA and JOT technologies and indicated that such a combination would greatly reduce the initial training time for first term maintenance personnel. The combined implementation of these technologies would result in two additional major benefits to the Navy. It would permit the training of medium aptitude personnel, in addition to the currently utilized, high aptitude personnel now required for the long traditional theory based training. And while providing these impressive personnel benefits, it would increase the efficiency of the performance of maintenance including a substantial reduction in spare parts usage. The realization of these benefits, however, requires the quality implementation of these technologies under the direction of personnel with successful experience in their applications. To do otherwise will invite "watered down" implementations followed by "watered down" if not disastrous, field results.

TABLE OF CONTENTS

	Page
I. Introduction . . . . .	1
II. The Project Plan . . . . .	5
The Electronic System Selected . . . . .	4
Presentation and Approval of the Plan . . . . .	4
III. Development of FPJPA/JOT . . . . .	5
IV. Conduct and Evaluation of the Training Programs . . . . .	6
Instructors . . . . .	6
Subjects . . . . .	6
Equipment Availability . . . . .	6
JOT Materials . . . . .	6
Modified Plan of Instruction . . . . .	6
Evaluative Statement Concerning Training . . . . .	7
V. Evaluative Tryout of FPJPAs . . . . .	7
Problem Selection . . . . .	7
Criteria for Successful Task Performance . . . . .	7
Data Collection . . . . .	8
Results . . . . .	8
VI. Comparison of Results with Other FPJPA Studies . . . . .	10
Training Equivalence . . . . .	10
Comparison of TS Task Complexity . . . . .	10
Equivalence of FPJPAs . . . . .	11
A Word Concerning the AFHRL Twelve Hour Study . . . . .	11
Presentation and Scope of Comparative Data . . . . .	11
Intermediate (I) Level Results . . . . .	12
Organizational (O) Level Results . . . . .	13
VII. Evaluative Statement Concerning the AN/AQA-7 FPJPAs . . . . .	14
VIII. Summary and Conclusions . . . . .	15
Lessons Learned . . . . .	17
Suggestions . . . . .	18
Acknowledgements . . . . .	19
References . . . . .	20
Reference Notes . . . . .	21

Accession For	
NTIS GNR&I	<input checked="" type="checkbox"/>
DDC TAB	<input type="checkbox"/>
Unannounced	<input type="checkbox"/>
Justification	
By _____	
Distribution/	
Availability Codes	
Dist	Avail and/or special
A	

Table of Contents (Continued)

	Page
Appendix A. Description of the Developmental Process for AN/AQA-7 Fully Proceduralized Job Performance Aids . . . . .	A1
Appendix B. Assessment of a Job Oriented Training Program in Support of Fully Proceduralized Job Performance Aids . . . . .	B1

LIST OF ILLUSTRATIONS

Figure		Page
1	Characteristics and content of the Fully Proceduralized Job Performance Aids (FPJPA) technology . . . . .	3
A-1	The Development of JPA and Training Materials . . . . .	A2
A-2	AQA-7 Data Coverage Plan . . . . .	A4
A-3	Example Page from TIM . . . . .	A6
A-4	Task-Step Data Details (TSDD) . . . . .	A8
A-5	Page from Generic Noun List . . . . .	A12
A-6	Example Test Equipment and Tool Use Form (TETUF) . . . . .	A13
A-7	Page from Task Inventory . . . . .	A14
A-8	Page from Style Guide . . . . .	A15
A-9	A Sample JPA Text Page . . . . .	A19
A-10	Standard Statements for the Sample JPA Text Page . . . . .	A21
A-11	Sample Action Tree Diagram for the Sample JPA Text Page . . . . .	A22
A-12	Example Failure Modes . . . . .	A25
A-13	Training Development Process . . . . .	A43
A-14	Sample Lesson Specification . . . . .	A48
A-15	Example Instructor Lesson Plan . . . . .	A55

LIST OF TABLES

Table		Page
1	Task Success of 12 Medium Aptitude Navy Subjects (40-50 Percentile) Using FPJPA for Organizational (O) Level Troubleshooting Tasks . . . . .	8
2	Task Success of 23 Medium Aptitude Subjects (40-50 Percentile) Using FPJPA for Intermediate (I) Level Tasks . . . . .	9
3	Comparison of the TS Performance in Percent of "O" Level Faults Isolated by Medium Aptitude Inexperienced Navy Subjects with the Performance of Control and Experimental Subjects in a Comparable Air Force Advanced Development Study . . . . .	11
4	Comparison of the TS Performance in Percent of "I" Level Faults Isolated by Medium Aptitude Inexperienced Navy Subjects with Performance of Control and Experimental Subjects in Air Force Studies . . . . .	12

List of Tables (Continued)

Table		Page
A-1	Lesson Titles . . . . .	A45
B-1	Mean Basic Test Battery Scores and California Reading Test Scores for "O" and "I" Level Classes . . . . .	B4
B-2	Readability of FPJPA Training Materials . . . . .	B5
B-3	Readability of FPJPA Maintenance Materials . . . . .	B5
B-4	Mean "O" Level Performance Scores on JPA Unit Tests . . . . .	B7
B-5	Mean "I" Level (A) Performance Scores on JPA Unit Tests . . . . .	B8
B-6	Mean "I" Level (B) Performance Scores on JPA Unit Tests . . . . .	B9
B-7	Critical Error Analysis for All "O" Level Ss . . . . .	B11
B-8	Critical Error Analysis for All "I" Level Ss . . . . .	B13
B-9	"O" Level Students' Rating of Training Course Units . . . . .	B17
B-10	"I" Level Students' Rating of Training Course Units . . . . .	B18
B-11	"O" Level Instructor's Rating of Training Course Units . . . . .	B19
B-12	"I" Level Instructor (A)'s Rating of Training Course Units . . . . .	B20
B-13	"I" Level Instructor (B)'s Rating of Training Course Units . . . . .	B21

## I. INTRODUCTION

Fleet feedback on systems developed at the Naval Air Development Center (NAVAIRDEVCCEN) has generated an increased awareness of training and technical maintenance documentation as critical factors in system design. While pursuing goals of increased system performance, it is recognized that any actual performance gains must be filtered through the maintenance capability of the average fleet technician. Chief of Naval Education and Training (CNET) has suggested that training costs can be cut by making training more job oriented and less broad and theoretical, especially for first term technicians. Chief of Naval Personnel (CHNAVPERS) through the Personnel Qualification Standards (PQS) Program has been supporting job specific On-The-Job Training (OJT). The PQS will specify what skills are required for a billet. Naval Air Systems Command (NAVAIR) (AIR-04A4) has been sponsoring research for improving the effectiveness of technical documentation to support the technician on the job. The Maintenance Information Automated Retrieval System (MIARS), the Technical Review and Update of Manuals and Publications (TRUMP), and the Work Package (WP) concept are three AIR-04A4 programs aimed at improvement of technical documentation.

These programs have become more critical with the advent of the All-Volunteer Force (AVF). The Navy Enlisted Occupational Classification System (NEOCS) study predicted a general reduction in reading level and other selection test scores of the AVF. And more recent projections indicate that due to the decrease in the number of people in the 19 to 20 age group in the next decade, the number of available high aptitude people will decrease. In addition, weapon systems have become more complex and as a result, traditional maintenance training programs, which have always required high aptitude students, have become longer and more costly. In spite of such expensive training, there is substantial evidence which indicates that much maintenance, although performed effectively, is not performed efficiently (Foley, 1975). So ways should be found to improve the quality of maintenance but with maintenance being performed by personnel of somewhat lower aptitude and with shorter initial training. NAVAIR is charged with providing the most cost effective training support and technical documentation for systems and, therefore, must adopt and/or develop approaches to cope with these changing Navy needs and must insure that these approaches are applied to systems under development and procurement.

Fortunately, the Research and Development (R&D) establishments of all the military services have developed and demonstrated the potential effectiveness of a number of relevant training models and improved maintenance guidance models, as well as combinations. The most effective improved maintenance guidance materials have reflected important aspects of the Fully Proceduralized Job Performance Aid (FPJPA) technology. (Step-by-step maintenance instructions in standard language, supported by pictorial locators, are essential but not sufficient identifying elements of this technology). Six previous FPJPA projects seemed to be especially applicable to a solution of many Navy maintenance problems.

*Three* of the six FPJPA projects applied to non-troubleshooting (non-TS) tasks (such as checkout, align, adjust, calibrate, and remove and replace) but *not* to troubleshooting (TS) tasks. These included the Air Force project, Presentation of Information for Maintenance and Operation (PIMO) (Serendipity, 1969), and two Navy projects, Advanced Manpower Concepts for Sea-based Aviation Systems (AMSAS) (Post & Brooks, Note 1) and Job Performance Aids Test (Horn, Note 2). These projects demonstrated conclusively that inexperienced technicians performing with Job Guides of the FPJPA variety could perform as well as or better than experienced personnel performing with or without Job Guides. And experienced personnel made fewer maintenance errors when performing with Job Guides than when performing in their traditional manner.

A *fourth* project, a controlled study (sometimes called the Twelve Hour Study) of the Air Force Human Resources Laboratory (AFHRL) (Elliott, 1967; Elliott & Joyce, 1968) concerned FPJPAs for TS. This was the first study which combined the FPJPA and job (task) oriented training (JOT) technologies. Both high and medium aptitude high school students received 12 hours of specific "hands on" training on

the use of test equipment and hand tools. These subjects performed TS tasks as well as did the experienced, high aptitude personnel with many months of training. These high school subjects used FPJPAs and the experienced technicians used traditional maintenance manual (TMM) materials. Although the experiment in this study was controlled, FPJPAs were not developed for an entire system. In addition, the FPJPAs used were rather primitive by current standards.

The *fifth* project was part of the Vietnamization program and concerned the development of FPJPAs for both non-TS and TS tasks for ten major systems or subsystems. (For a summary of this effort, see Foley, 1978a.) This project was based on both the PIMO and the AFHRL efforts. During this project, a great deal was learned concerning the development of FPJPAs by contractors not familiar with the concept. The most important long-range outcome of this project was the development of an adequate specification (Mil-J-83302) and guidance handbooks (Applied Science Associates, 1971a & 1971b). With the development of these documents, the FPJPA concept emerged as a true technology. These documents were later Americanized and published as a three-volume technical report, AFHRL-TR-71-53 (Folley et al., 1971a, 1971b; Joyce et al., 1971). These Americanized documents have since been updated and published by AFHRL as another three-volume technical report, AFHRL-TR-73-43 (Joyce et al., 1973a, 1973b, 1973c). The characteristics and requirements of FPJPA technology are summarized in Figure 1.

The *sixth* project was a 1972 AFHRL demonstration of the potential effectiveness of combining FPJPAs for TS tasks and JOT at Altus Air Force Base (Mullen & Joyce, 1974). The FPJPAs used for this demonstration concerned organizational (O) and intermediate (I) level maintenance of the Doppler navigation radar, AN/APN-147, and its computer, AN/ASN-35. These FPJPAs were developed prior to the development of the specification and guidance handbooks. A 4-week JOT program concerning non-TS tasks, such as remove and replace and use of test equipment, hand tools, and FPJPAs, was developed for this demonstration. Eight high electronic aptitude subjects and eight medium aptitude subjects were assigned, immediately after completing basic training, to a job oriented 4-week course. At the request of NAVAIR, the author observed a segment of the Altus demonstration. The subjects were able to perform most of the typical "O" and "I" level tasks given them. Even though the subjects performed reasonably well, the project manager indicated that he believed the effectiveness of both the FPJPAs and the JOT could be improved by the development of FPJPAs in keeping with the previously mentioned specification and guidance of AFHRL-TR-71-53 (Folley et al., 1971a, 1971b; Joyce et al., 1971) and by adding more task practice to the JOT. But despite these limitations of the Altus demonstration, it was evident to the author that the FPJPA technology represented a coordinated, as well as a feasible, approach to technical documentation. In addition, this demonstration supported the hypothesis that a coordinated FPJPA/JOT program could significantly reduce training costs while improving electronic system maintenance, including TS.

This hypothesis was further supported by an independent investigation sponsored by the Department of Defense (DoD) (Rowan, 1973). In this investigation, Rowan concluded that non-TS FPJPAs or job guides coupled with JOT have received sufficient study and validation to support their adoption by DoD for "O" level maintenance. He estimates a saving of 1.25 billion dollars annually from this recommendation. He further recommended continued testing, citing the present study, to determine whether the FPJPA techniques can be applied to "O" level TS and all "I" level maintenance tasks. Based on the hypothesis that the FPJPA/JOT combination had great potential, a demonstration/evaluation was proposed by the NAVAIRDEVEN to ascertain the effectiveness of this combination for both TS and non-TS tasks at both the "O" and the "I" levels of maintenance. The proposal was made to the Chief of Naval Operations (CNO) (OP-59) and to NAVAIR (AIR-413, AIR-04A4).

FPJPA is the generic name of a technology which can be used in the development of step-by-step directions for both non-troubleshooting (non-TS) and troubleshooting (TS) tasks. The current technology contains aspects obtained from several sources, including the AFHRL exploratory development efforts, the first AFHRL advanced development effort (1967-72), the Presentation of Information for Maintenance and Operation (PIMO) project, and JPA projects for Vietnamization. (The 12-hour study was one of the AFHRL exploratory efforts and the Altus demonstration was part of the first AFHRL advanced development effort.) Currently, AFHRL-TR-73-43, a three-volume technical report, provides the best description and directions concerning the FPJPA technology for both non-TS and TS tasks (See Joyce et al., 1973a, b, and c). The most important addition to this report is found in AFHRL-TR-75-38 (Shriver, 1975) concerning improved cues for step-by-step directions. This figure is a summary of a description of the FPJPA technology by Foley (1978a). The technology has the following characteristics and content.

**Task Identification and Analyses (TI&A) of Identified Tasks** - A unique characteristic of this technology is the formal requirement for the development and use of TI&A. To ensure the effective job support for non-TS by FPJPA, an aid must be considered for every task of a hardware to be maintained. This requires the development and use of a task identification matrix (TIM). Each FPJPA must contain accurate and complete step-by-step instructions, keyed to pictorial locators for its task. And each FPJPA must contain all of the cues necessary for individuals of the target populations to perform the task. FPJPA for TS tasks must be built around a logic or troubleshooting tree that identifies all the troubleshooting signatures. There must be a signature for each replaceable component assigned to the level of maintenance for which the TS aids are being developed. For each decision point in the TS tree, accurate step-by-step instructions, with the necessary cues, must be developed. These characteristics are insured by the development and application of a number of task analysis products which are required by the AFHRL-TR-73-43 specification. To ensure the completeness and adequacy of these required products of formal TI&A, there must be timely periodic in-process reviews and official acceptances of these products by knowledgeable DoD representatives. These products then become criteria for the structure and completeness of the FPJPA to be used during their development.

**Standard Language and Keyed Pictorials for Maintenance Instructions** - Another unique characteristic of FPJPA, which came from the PIMO project, is a standard language. Each maintenance direction is limited to a total of three sentences and a total 25 words. Each of these sentences is limited to 10 words. The first word of each sentence is an action verb in the second person taken from a standard verb list. In addition to standard verbs, all nouns are cross-referenced (keyed) to a locator pictorial which indicates to the user the appearance of the item and its location in the hardware. This standard language provision coupled with the pictorial locators reduce the reading requirements of the user to a minimum.

**Format** - Using TI&A, standard language, and keyed pictorial locators for content determination and considering the job environment in which the identified tasks were to be accomplished, several appropriate formats have been developed to date. But it is important to remember that the necessary content of the aids is far more important than the format. A format similar to that developed for the PIMO project has usually been used for non-TS tasks at the "O" level of maintenance. Instructions have been formatted in a rather small booklet with instructions on the left-hand page and the locator pictorials on the right hand. Some applications have provided pictorial foldouts, each of which is applied to more than one page of instructions. There have been two formats used for FPJPA for TS tasks: one in which the instructions have been placed in blocks and the blocks connected by flow lines to indicate branching, similar to Logic Tree Troubleshooting Aids (LTTA) and the other in which the instructions have been placed in a scrambled book. The scrambled book format produces a document that looks very similar to FPJPA for non-TS tasks. The branching in the scrambled book is provided by directions to go to the page on which the instructions are given. Future applications of the FPJPA technology may result in other formats which will better meet the needs of some users. The point is that the FPJPA technology is not limited by format nor is it truly represented by format. It is possible to apply any of the formats mentioned here, without the content control of the TI&A, but such applications cannot legitimately be considered true implementations of the FPJPA technology.

**Validation and Verification** - Validation of maintenance manuals by the contractor, followed by verification by the appropriate DoD agency, has long been part of maintenance policy. In some cases these requirements involve only table top inspections of the final products. However, in the past, with the exception of corrections for obvious errors in directions and format, little could be accomplished by these processes to insure the job effectiveness of maintenance manuals. Several applications of the FPJPA technology have indicated that no matter how carefully the TI&A was accomplished and monitored and no matter how carefully the resulting criteria were applied, a very careful "hands on" validation and verification of the results are required. For maximum effectiveness, one of these efforts should include "hands on" equipment tryout of directions by members of the target populations for which the directions have been developed. Another safeguard which was applied in developing aids for the C-141 aircraft was a three-year warranty by the contractor of his product. To insure maximum effectiveness of the FPJPA technology, such warranties should be obtained for all future applications.

Figure 1. Characteristics and content of the Fully Proceduralized Job Performance Aids (FPJPA) technology. (This figure was prepared by Dr. John P. Foley of the Advanced Systems Division, of the Air Force Human Resources Laboratory.)

## II. THE PROJECT PLAN

This effort was planned in 1972 as a full scale controlled study to determine the relative effectiveness of the combined FPJPA and TOT technologies with respect to traditional theory based training and TMM. (Unfortunately, as will be discussed later, the controlled comparative aspects of this plan were never completed.)

The formal objective of the project was to test whether a 12-week job oriented course, when combined with FPJPAs, could prepare recruit training graduates with 45-52 scores on the General Classification Test (GCT) to maintain a typical Navy aircraft electronic subsystem at the "O" and "I" levels. The project would differ from the AFHRL Altus project in two important respects. The FPJPAs would be developed in keeping with the latest version of the specification and guidance documents (AFHRL-TR-71-53, Folley et al., 1971a, 1971b; Joyce et al., 1971). The JOT developed for this effort would be longer than the Altus JOT and would thus provide more job task practice. Like the Altus program, it would minimize the amount of traditional theory. During the planning of this research and development (R&D), close coordination, guidance, and support was provided by Dr. John P. Foley, who was at that time directing the FPJPA R&D program of the AFHRL, Advanced Systems Division at Wright-Patterson Air Force Base. The Altus effort was part of this AFHRL FPJPA program.

### The Electronic System Selected

The AN/AQA-7 Sonar Signal Processing System was selected as the system to be maintained for this project. This sonar is installed in the S2G and P-3 series aircraft. It was selected because it was representative of a state-of-the-art, extremely complex electronics system containing mostly solid state micro-electronics components, as well as some discrete and tube components. The maintenance concept for the "O" level consisted primarily in TS to a "black box" level or large card. (TS was supported by a relatively effective Built-in Test Equipment (BITE).)

Although it changed later, at the time of its selection the maintenance concept for the "I" level of maintenance required technicians to TS only to the card level or to a discrete component. If a card, identified as defective, contained a defective integrated circuit or chip, the card was sent to the depot level for repair. If the card contained only discrete components, TS continued to the defective component which was replaced. The "I" level technician was required to use the following test equipment: Digital Voltmeter, Oscilloscope, Differential Voltmeter, North Atlantic Phase Meter, and Multimeter. The test equipment was incorporated in the AWM-18, AQM-20 test bench.

### Presentation and Approval of the Plan

This project plan was presented to the Chief of Naval Education and Training (CNET), the Chief of Navy Technical Training (CNTECHTRA) and the Naval Aviation Maintenance Training Group (NAMTRAGRU). With their concurrence in the desirability of a test of the project goals, CNO (OP-59) issued a message directing support for the project. CHNAVPERS arranged for the selection of 40 volunteer recruits to participate in the experimental tryout. CNTECHTRA offered his assistance in evaluating the JOT. NAMTRAGRU provided one instructor and the facilities of the Naval Air Maintenance Training Detachment (NAMTRADET), Cecil Field, Florida. NAMTRADET rescheduled their courses with the cooperation of Air Anti-Submarine Wing (COMAIRASWING) ONE, Cecil Field, to make classroom spaces and equipment available for the development of the FPJPAs and for use in the training course. The Commander, Patrol Squadron 49 (PATRON FOUR NINE) provided two additional instructors for use in the administration of the training.

The coordination of these many commands was facilitated by their enthusiastic attitude toward innovation and their awareness of the problems faced in the AVF. It was recognized that the results of the present study, if successful, would suggest the elimination of broad theoretical training being given at "A" school and modification of the JOT presently given at NAMTRADETS. Trainees, lacking the broad

theoretical training, would be at a great disadvantage in competing in the present Navy advancement examinations. Therefore, the introduction of FPJPA/JOT would require coordinated changes in these examinations. However, in briefings on this project provided to the NEOCS director, it was noted that NEOCS planned changes which will allow the Navy advancement system to accommodate first enlistment sailors who had received JOT rather than the traditional theory based training.

### III. DEVELOPMENT OF FPJPA/JOT

The FPJPAs for the AN/AQA-7 were developed in accordance with the then latest version of the FPJPA specification and guidance documents presented in the three volume AFHRL-TR-71-53 (Folley et al., 1971a, 1971b; Joyce et al., 1971) mentioned previously. These aids were developed in two contractual steps at the suggestion of Dr. Foley of AFHRL. The first step was the development of a task identification matrix (TIM) for the AN/AQA-7 and a sample FPJPA. The TIM ascertained the number and type of tasks for which FPJPAs should be prepared and thus described the scope and magnitude of the FPJPA production effort. This work was accomplished by a \$69,000 sole source contract with Applied Science Associates, Inc. (ASA) of Valencia, Pennsylvania, the contractor who had developed AFHRL-TR-71-53, specification and guidance documents (Folley et al., 1971a, 1971b; Joyce et al., 1971). This TIM and sample FPJPA formed the bases for a request for bid (RFB) for the second contractual step, a multi-source procurement for the production of the FPJPA. Two contractors submitted proposals which were rated by representatives of NAVAIR (AIR-413 and AIR-04A4). On the basis of these ratings followed up by on-site discussions with management personnel, ASA was awarded the \$292,000 production contract.

The services of a technical representative of the manufacturer of the AN/AQA-7 (Magnavox) were obtained to provide for quality assurance on maintenance procedures. All drafts of TS and non-TS procedures were reviewed for effectiveness and signed by this Magnavox representative. This service cost \$25,000.

Based on another multi-source procurement, a \$112,000 contract for the development of the JOT materials was awarded to ASA. Key personnel of this organization had extensive R&D experience in both FPJPA and JOT technologies; this firm had conducted all of the AFHRL contract exploratory development concerning FPJPAs, had developed the FPJPA specification Mil-J-83302 and its two guidance documents (Applied Science Associates, 1971a, 1971b), and had conducted an extensive AFHRL JOT program called Learner-Centered Instruction (LCI) (Pieper, Swezey, & Valverde, 1970). In addition, ASA had developed both the FPJPAs and matching JOT for the Altus AFB demonstration and had conducted that demonstration (Mullen & Joyce, 1974). Such extensive experience had uniquely qualified this contractor to integrate the JOT with the FPJPAs. As a result, a good match between the FPJPAs and the JOT was achieved. (However, as will be discussed later, problems were encountered concerning timely delivery.)

The goals of the training program were to reduce the theoretical content to an absolute minimum, to use programmed instruction as much as possible, and to introduce the subject to the use of FPJPA-like materials as early as possible. Since one of the major problems cited by the researchers at Altus AFB was insufficient task practice - the training was to provide as much practice as possible within a 12-week course. The JOT packages ultimately developed, based on the TIM, were somewhat longer. The package for the "O" level program required 13 weeks; for the "I" level, 16 weeks. Appendix A authored by Thomas K. Elliott of ASA provides a detailed discussion of the procedures used to develop both the FPJPAs and the relevant JOT. This material should be "must" reading for anyone planning for or developing JOT and/or FPJPA efforts.

The standard pipeline for maintenance of the AN/AQA-7 required approximately 22 weeks of training for qualification in the AX rating, followed by 2 weeks of "O" level and 14 weeks of "I" level training in the NAMTRADET, for a total of 24 weeks for "O" level and 36 weeks for "I" level. When compared to the standard 24 week "O" level program, the 13 week "O" level JOT represents a 45.8 percent reduction in training time. When compared to the standard 36 week "I" level program, the 16 week "I"

level JOT represents a 55.5 percent reduction in training time. Thus, the FPJPA JOT program time and costs are significantly lower than that of the "A" and "C" school graduate who normally performs the same functions.

#### IV. CONDUCT AND EVALUATION OF THE TRAINING PROGRAMS

The original plan for the conduct of training was based on the following assumptions:

1. There would be four instructors: two to teach "I" level maintenance and two to teach "O" level maintenance.
2. The subjects would arrive in four groups of 10 each approximately 1 to 2 weeks apart.
3. Two AN/AQA-7 systems and two AQM-18 test benches could be made available for the exclusive use of the project.
4. Access to S2G aircraft (with operating AQA-7s) could be obtained.

Unfortunately, none of these conditions were met.

##### Instructors

Three instead of four instructors were obtained. Those obtained, however, were senior Navy enlisted technicians. The Officer-in-Charge of the Naval Air Maintenance Training Detachment (NAMTDET) at Cecil Field provided AWC Robert Henry. He had previously instructed "A" school graduates in the repair of the AN/AQA-7 and was a graduate of Navy instructor school. PATRON FOUR NINE provided two additional experienced AN/AQA-7 operators, both with experience in the operation and maintenance of the AN/AQA-7: AWC Tom Pope and AWI James Moore.

##### Subjects

Although the desired number of subjects, 41, with the proper aptitudes, were assigned to the project by CHNAVPERs, they arrived early and all in one group instead of four. These were volunteers whose selection test scores were below the cutoff for eligibility to "A" school (GCT + ARI + MECH = 170). The following test scores were stipulated: GCT 45-52, ARI 45-52, MECH 45-52 with GCT + ARI + MECH = 140 to 150. This composite placed the subjects' aptitudes for electronics training in approximately the 40 to 50 percentile range.

##### Equipment Availability

Instead of the planned two AN/AQA-7 systems and two AN/AQM-18 test benches, only one of each was obtained. And due to the heavy flight commitments of COMAIRASWING ONE, access to S2G aircraft was limited.

##### JOT Materials

As mentioned previously, the JOT materials were delivered approximately 1 month late and not properly collated. This late delivery was not anticipated in sufficient time to delay the arrival of the subjects. In addition, the departure of the subjects could not be delayed.

##### Modified Plan of Instruction

While the subjects were waiting for the JOT materials to be delivered, they were given general background courses on Naval aviation and the 3-M maintenance system. It was also decided to use the standard 2-week miniature component repair course to teach soldering. This decision was taken with the understanding that the trainees lacked familiarity with the normal prerequisites for the miniature component repair course. However, if they successfully completed this course, they could later attend the

micro-miniature repair course and obtain certification as micro-miniature repairmen. These improvisations provided the time needed to deliver the JOT packages.

After delivery and assembly of the training materials, the 41 trainees were divided into three sections. two sections of 13 trainees each were assigned to "I" level training and one section of 15 trainees was assigned to "O" level training. (Of those, three "O" level and three "I" level subjects were dismissed from the project for non-academic reasons. As a result, 12 "O" level and 23 "I" level subjects completed training and were utilized in the experimental tryout of the FPJPAs.) Since only one AN/AQA-7 and AN/AQM-18 test bench could be made available for instruction, it was decided to establish a 24-hour teaching day consisting of three 8-hour sessions. Sessions were scheduled Monday through Thursday to conform with the normal NAS Cecil Field work week. Arrangements were made with the Aviation Intermediate Maintenance Department of NAS Cecil Field to obtain priority repairs to the AN/AQA-7 components used in training. Despite this excellent support, however, many training hours were irretrievably lost due to equipment being inoperative for maintenance.

#### **Evaluative Statement Concerning Training**

Under these circumstances, the full potential of the JOT could not be realized. The reduced number of instructors and the larger than planned class sizes reduced the amount of individual attention each subject could receive. The time allowed for the JOT program was shorter than planned, which reduced the opportunities for subjects to receive the planned amount of "hands on" task practice. These opportunities were further reduced by insufficient availability of equipment. Even with all these violations of the training ground rules, the JOT program was reasonably effective. The omission of training on the dual beam feature of the oscilloscope was its only major deficiency. More detailed information concerning the quality of the training materials, the conduct of the training and the students' attitudes toward the training are presented in Appendix B. This appendix was prepared by Lt Robert P. Fishburne, who was assigned to this project by RADM Albert M. Sackett, Chief of Naval Technical Training, CNTT.

### **V. EVALUATIVE TRYOUT OF FPJPAs**

#### **Problem Selection**

The evaluation of the subjects' ability to perform job tasks using FPJPAs sought to provide as realistic as practicable a work setting with representative maintenance problems. However, in order to gather adequate samples of data, problems were selected which could be solved in approximately 50 minutes using the FPJPAs. Discussion were held with the N.A.S. Cecil Field Intermediate Maintenance Activity, the Magnavox representative, and the NWESA field engineers. Problems were selected which had high frequency of occurrence as reported on 3M data. Each problem was then "solved" using the FPJA procedures. In four cases the problems took longer than 50 minutes. In these cases the problem was shortened by starting the evaluation with "set up" and checkout steps already completed. The steps eliminated were usually just equipment warm-up tests or switch setting steps, and in no case did these eliminations result in a simplifying of the problem for the subject. The data collection had to be accomplished in 4 weeks because the equipment and subjects had to be released at that time. It was only possible to administer five problems to each of the 12 "O" level subjects and four problems to each of the 23 "I" level subjects. It would have been desirable to obtain data for a larger number of problems; however, the problems selected are considered representative.

#### **Criteria for Successful Task Performance**

The basic measure of human performance used in this evaluative tryout was in terms of acceptable products. Each desired product was the successful completion of a maintenance task without assistance. This was a go, no-go criterion. The resulting product data are presented in terms of percentage of such tasks completed. In the real world of maintenance, correct performance of maintenance tasks is not always obtained on the first attempt, but efficiency demands such performance as a goal.

Time data were also obtained for each task and are presented in terms of mean time for tasks successfully completed. The time required to perform a maintenance task correctly is seldom critical at the "I" level of maintenance provided it is performed in a reasonable time. But under some circumstances, time available for accomplishing such correct performance is limited and/or critical. The circumstances, where speed of performance becomes critical, are usually found at the "O" level of maintenance. Examples include; (a) the requirement for correction of system malfunctions discovered during preflight checkouts, (b) situations where turnaround time of aircraft is critical, and (c) power plant failures which cause electrical outages. Normally when speed is a critical aspect of task performance, it should be made part of the go, no-go criterion, i.e., the subject should be able to perform the task successfully within the critical time limit. However, for evaluative tryouts such as this one, time factors have not been included in the go, no-go criteria for successful completion of tasks.

Since the success of performance is always a prime requirement, task success data were the primary criteria for this evaluative tryout and are presented first in the presentation and discussion of results. (As was discussed previously, the time to perform a task using FPJPA was an important consideration in selection of tasks for this evaluation due to scheduling factors.)

#### Data Collection

The data were collected over a 4-week period. Each day consisted of 8 to 11, 50-minute sessions and each subject was tested at the rate of one session per day for 5 ("O" level) or 4 ("I" level) consecutive days. Prior to the beginning of each day's sessions, the system was checked by the Magnavox representative, and the problem selected for that day was inserted in the system. The same problem was used for all sessions during any 1 day.

NWESA field engineers had been assigned the task of data collection for two reasons: (a) they had previous experience with JPA evaluations and (b) they could serve as objective, unbiased observers since they had not been involved in the earlier portions of the evaluation.

Each subject was instructed, at the beginning of a session, as to his entry step for the problem. If this step was not step 1 in his book, it was explained that all previous steps had been completed and that the system was checked to the entry step that he was given. Initial planning called for no help to be provided to the subjects: data collectors merely recorded the steps taken by the trainee. This rule was slightly modified so that if the subject went off on a completely erroneous tangent, he would be stopped, told to leave the room, and be brought back in a few minutes to try the problem one more time.

#### Results

Table 1 presents the data concerning the successful completion of "O" level TS problems selected for the evaluative tryout.

*Table 1. Task Success of 12 Medium Aptitude Navy Subjects (40-50 Percentile) Using FPJPA for Organizational (O) Level Troubleshooting Tasks*

Problem Identification	Percent of Problems Successfully Completed	Mean Time Required in Minutes	
		$\bar{x}$	SD
19A2	90.5	35.8	12.0
20A-1	91.1	17.6	5.6
1A1	97.1	47.0	2.8
4A2	57.5 <sup>a</sup>	21.8	6.6
FMS#2	97.0	51.0	21.2
Composite of "O" Level:	86.6		

<sup>a</sup>Problem required each subject to use the dual beam feature of the oscilloscope. Subjects had received no training concerning this feature of the scope.

It should be noted that the five "O" level problems were all TS problems. With the exception of the 4A2 problem, all of the percentages were over 90 percent. As indicated in Table 1, the primary cause of the 57.5 percent results for problem 4A2 must be attributed to a training weakness. The subjects had received no training on the use of the dual beam feature of the oscilloscope. The composite figure for "O" level TS performance including the 4A2 problem was 86.6 percent; excluding the 4A2 problem, 93.9 percent. Time data concerning these "O" level problems are indicated in the third and fourth columns of Table 1.

Table 2 presents the data concerning the successful completion of "I" level problems by 23 subjects.

Table 2. Task Success of 23 Medium Aptitude Subjects (40-50 Percentile) Using FPJPA for Intermediate (I) Level Tasks

Problem Identification	Non-TS	TS	Percent of Problems Successfully Completed	Mean Time Required in Minutes	
				X	SD
6A4	X	X	84.4	50.2	11.6
PP6306		X	93.7	37.8	11.3
4A2	X (Align)		68.2 <sup>a</sup>	49.1	21.3
11A3	X (Align)		82.5	51.6	13.0
Composite TS Problems			89.1		-
Composite Non-TS Problems			75.4		
Composite "I" Level			84.1		

<sup>a</sup>Problem required each subject to use the dual beam feature of the oscilloscope. Subjects had received no training concerning this feature of the scope.

As to the two TS problems, the 6A4 problem was more complex than the PP6302 problem. The 6A4 TS task added the clutter of the non-TS elements of adjustment and of the use of the oscilloscope. This complexity was reflected in the results: 84.4 percent success for the 6A4 task compared to 93.7 success for the PP6306 task. In the writer's opinion, the 6A4 task was more representative of "I" level TS tasks, generally, than the simpler PP6306 task. The composite for the two TS tasks was 89.1 percent.

As to the non-TS alignment tasks 4A2 and 11A3, the 82.5 percent success rate for the 11A3 alignment task was higher than the rate for 4A2 alignment task but lower than any of the "O" or "I" level TS tasks except the 4A2 "O" level TS task. The low 4A2 alignment performance (68.2 percent) reflected the same training omission of the dual beam feature of the oscilloscope as did the 4A2 "O" level TS performance. Time data for these "I" level problems are indicated in the fifth and sixth columns of Table 2.

A number of key questions should be answered concerning the relative effectiveness of the task performance of these medium aptitude Navy subjects using FPJPA who received only 13 or 16 weeks of JOT, such as how do the results for these medium aptitude subjects compare with:

1. The performance of current experienced Navy personnel *using TMM* who now maintain the AN/AQA-7? (These are high aptitude personnel who have received much longer training - 24 weeks for "O" level and 36 weeks for "I" level.)
2. The performance of such experienced Navy technicians *using FPJPAs*?
3. The performance of inexperienced, high aptitude Navy personnel *using FPJPAs* who have completed the current long training?
4. The performance of both experienced and inexperienced high aptitude personnel *using FPJPAs* who have completed the shorter JOT programs instead of the longer current training?

Answers to such pertinent questions would have been provided by the data from the originally planned full scale controlled study. Due to funding problems, such data were never collected. However, in the absence of these more desirable data, answers to some of these questions can be obtained by substituting applicable control and experimental data from an AFHRL study (Potter & Thomas, 1976). In addition some relevant data are available from a less extensive Air Force study (Elliott, 1967; Elliott & Joyce, 1968), sometimes called the "Twelve Hour Study." The scope of these AFHRL studies was limited to the effectiveness of the FPJPA technology for supporting the performance of *TS tasks*. They did not study the effects of FPJPAs on non-TS tasks per se.

#### VI. COMPARISON OF RESULTS WITH OTHER FPJPA STUDIES

The appropriateness for comparing the data from this NADC evaluative tryout with control and experimental data from the AFHRL Advanced Development Study (Potter & Thomas, 1976) is based on four assumptions:

1. The training received by the experienced high aptitude Navy AN/AQA-7 system technicians and the Air Force AN/APN-147-AN/ASN-35 system technicians were reasonably equivalent.
2. The TS tasks demanded by the AN/AQA-7 system and the AN/APN-147-AN/ASN-35 system were of equivalent complexity.
3. As a result of assumptions 1 and 2, the TS capabilities of the Navy and Air Force technician to perform TS were also reasonably equivalent.
4. The FPJPAs for TS for the AN/AQA-7 system and the AN/APN-147-AN/ASN-35 system are of equivalent effectiveness.

#### Training Equivalence

As indicated previously, the standard formal training for Navy AN/AQA-7 technician requires approximately 22 weeks of basic electronic fundamentals training for qualification in the AX rating followed by 2 weeks of AN/AQA-7 task specific training for the "O" level of maintenance and by 14 weeks of AN/AQA-7 task specific training for the "I" level. These times make a total of 24 weeks for the "O" level and 36 weeks for the "I" level. The standard formal training required for both "O" and "I" Air Force technicians maintaining the AN/APN-147-AN/ASN-35 system was 36 weeks. This included 18 weeks of basic electronic fundamentals and 18 weeks of theory oriented training on four representative electronic systems, one of which was the AN/APN-147-AN/ASN-35 system. The AN/APN-147-AN/ASN-35 technicians received their task specific "O" and/or "I" level training by OJT after job assignment. So it is a reasonable assumption that after 6 months experience on the job the TS performance capabilities using TMM for such Air Force and Navy technicians would be comparable.

#### Comparison of TS Task Complexity

From the stand point of electronic complexity, the Navy AN/AQA-7 Sonar used in this NADC study is more complex than the Air Force AN/APN-147 and its computer, the AN/ASN-35. Since "O" level maintenance was only concerned with Line Replaceable Units (LRUs), this difference in electronic complexity would have had little or no effect on the TS tasks at the "O" level. The maintenance concept and complexity of TS tasks when performed with TMMs at the "O" level are considered to be comparable.

As to the "I" level of maintenance, the differences in difficulty of solving TS problems *with TMMs* between the AN/APN-147-AN/ASN-35 system (used in the AFHRL Advanced Development Study) and the Navy AN/AQA-7 is not too great. Even though the electronic complexity of the AN/AQA-7 was greater than that of the AN/APN-147-AN/ASN-35, their "I" level maintenance concepts were different. Since the Shop Replaceable Units (SRUs) for the AP/APN-147-AN/ASN-35 system included the smallest piece parts,

the complexity of TS with TMMs at the "I" reflected the full complexity of the hardware. Whereas, the complexity of TS with TMMs for the AN/AQA-7 did not reflect its full electronic complexity since most of the SRUs for this system were circuit boards, at the time this NADC evaluative tryout was approved. (This "I" level maintenance concept for the AN/AQA-7 was later expanded. At least some circuit board components were designated as SRUs. But these changes were not reflected in this evaluative tryout.)

**Equivalence of FPJPAs**

Since the FPJPAs used for solving TS problems in the NADC effort and for the AFHRL Advanced Development Study were both developed in keeping with the FPJPA technology described in Figure 1, these FPJPA are considered to be equally good representatives of the technology and of comparable quality. (The degree to which the AN/AQA-7 FPJPAs reflect the FPJPA technology is discussed in the next section of this report.) As a result, the FPJPAs used in the two efforts are considered to be of equivalent effectiveness.

**A Word Concerning the AFHRL Twelve Hour Study**

Although data from the AFHRL Twelve Hour Study (Elliott, 1967; Elliott & Joyce, 1968) are also included in the comparative analyses that follow, the equivalency between this AFHRL study and the NADC evaluative tryout is not as great as the equivalency between AFHRL Advanced Development Study and the NADC evaluative tryout. The FPJPAs used were the first such aids developed for TS and were rather primitive examples of the FPJPA technology. The experimental subjects were both medium and high aptitude, high school students who had received only 12 hours of JOT instead of 13 or 16 weeks as in the NADC evaluative tryout. However, the control subjects who performed TS with TMMs were highly trained and experienced Air Force technicians who were probably equivalent in TS capability to the control subjects of the Advanced Development Study or to experienced Navy AN/AQA-7 technicians.

**Presentation and Scope of Comparative Data**

Tables 3 and 4 present composite TS data in terms of percent of faults isolated for "O" and "I" level maintenance, respectively.

*Table 3. Comparison of the TS Performance in Percent of "O" Level Faults Isolated by Medium Aptitude Inexperienced Navy Subjects with the Performance of Control and Experimental Subjects in a Comparable Air Force Advanced Development Study*

TMM Control Group AFHRL Adv Dev Study	Type of Subjects	FPJPA Experimental Groups	
		AFHRL Adv Dev Study	Navy NADC Tryout
	<b>High Aptitude</b>		
100 <sup>a</sup>	More than 6 mo experience	95.8	—
100 <sup>a</sup>	6 mo or less experience	100	—
—	Inexperienced	88.9	—
	<b>Medium Aptitude</b>		
—	Inexperienced	—	93.9 (86.6) <sup>b</sup>

<sup>a</sup>Subject permitted to remove and replace Line Replaceable Units (LRU) until faults were isolated.

<sup>b</sup>The 86.6 percent figure is the composite figure from Table 1. The 93.9 figure excludes problem 4A2 which required the use of the dual beam feature of the oscilloscope. Subjects had received no training on this feature.

Table 4. Comparison of the TS Performance in Percent of "I" Level Faults Isolated by Medium Aptitude Inexperienced Navy Subjects with Performance of Control and Experimental Subjects in Air Force Studies

TMM Control Groups		Type of Subjects	FPJPA Experimental Groups		
AFHRL 12 Hour Study	AFHRL Adv Dev Study		AFHRL 12 Hour Study	AFHRL Adv Dev Study	Navy NADC Tryout
<b>High Aptitude</b>					
84.2	78.8 <sup>a</sup>	More than 6 mo experience	—	95.4	—
—	60.6 <sup>a</sup>	6 mo or less experience	—	95.4	—
—	—	Inexperienced	93.0	88.8	—
<b>Medium Aptitude</b>					
—	—	Inexperienced	82.0	—	89.1

<sup>a</sup>Subjects permitted to remove and replace Shop Replaceable Units (SRU) until faults were isolated.

Performance success data for non-TS tasks are not included since all of the tasks utilized in the AFHRL Advanced Development Study and in the Twelve Hour Study were TS tasks and the NADC evaluative tryout used only two non-TS tasks at the "I" level and no non-TS tasks at the "O" level. TS data for both control and experimental groups from these studies are included. These tables include only experimental group data for this Navy evaluative tryout.

#### Intermediate (I) Level Results

An examination of Tables 3 and 4 indicates that the most impressive improvement in TS success from use of FPJPAs are obtained at the "I" level of maintenance. Table 4 indicates that the medium aptitude (40 to 50 percentile) Navy subjects with 16 weeks of less than ideal JOT obtained a success rate of 89.1 percent on "I" level TS problems using FPJPAs. This success rate is most impressive when compared to Air Force control subject data.

1. This 89.1 percent success rate was 10.3 percent higher than the 78.2 percent success rate obtained by TMM control subjects of AFHRL Advanced Development Study with more than 6 months experience.
2. It was 28.5 percent higher than the 60.6 percent success rate obtained by TMM control subjects of the same AFHRL study with 6 months or less experience.
3. It was 4.9 percent higher than the 84.2 percent success rate obtained by TMM control subject of the earlier AFHRL Twelve Hour Study.

When comparing either the Air Force or Navy success rates for inexperienced or experienced subjects using FPJPAs with those rates obtained by experienced subjects using TMMs, it should be emphasized that these experienced control subjects used TMMs to remove and replace components until the fault was corrected. When using FPJPAs, subjects were not permitted to use this "shot gun" method of fault isolation. This current practice of replacing components until faults are corrected, results in high spare parts usage at the "I" level of maintenance and excess LRUs handling and paper work at the "O" level. This practice, also, results in a large amount of secondary damage to hardware which must be corrected later.

In addition, this 89.1 percent success rate on "I" level TS problem obtained by the medium aptitude Navy subjects using FPJPAs compares favorably with the success rates obtained by the experimental subjects of the AFHRL studies.

1. It was slightly higher than 88.8 percent TS success rate obtained by conventionally trained, high aptitude inexperienced subjects using FPJPAs in the AFHRL Advanced Development Study.

2. It was only 6.3 percent lower than the 95.4 percent TS success rate obtained by both categories of high aptitude experienced subjects using FPJPAs in the same AFHRL study - those with more than 6 months experience and those with 6 months or less experience.

3. It was 7.1 percent higher than the 82.0 percent TS success rate obtained by the *medium* aptitude, inexperienced high school subjects using FPJPAs in the same Twelve Hour Study.

4. It was only 3.9 percent lower than the 93.0 percent TS success rate obtained by the high aptitude, inexperienced high school subjects using FPJPAs in the AFHRL Twelve Hour Study.

It can be concluded that the Navy medium aptitude "I" level subjects with only 16 weeks of JOT performed TS tasks exceedingly well with FPJPAs when compared to Air Force high aptitude control subjects with more than 6 months experience who used TMMs. These Air Force control subjects had received 36 weeks of formal theory based training prior to job assignment. It can be assumed that those Navy medium aptitude "I" level subjects would have shown a similar degree of superiority if compared to experienced Navy AN/AQA-7 "I" level technicians.

It can also be assumed that these Navy medium aptitude "I" level subjects performed as well with FPJPAs as did the Air Force high aptitude *inexperienced* subjects using FPJPAs. These Air Force subjects had received 36 weeks of formal theory based training.

#### Organizational (O) Level Results

Table 3 indicates that the medium aptitude (40 to 50 percentile) Navy subjects with 13 weeks of less than ideal JOT obtained a success rate of 86.6 percent on "O" level TS problems using FPJPAs. If problem 4A2 which required the use of the dual beam feature of the oscilloscope is excluded, this success rate increases to 93.9 percent. This 93.9 percent figure is probably more representative concerning the power of FPJPAs since this oscilloscope training deficiency could be easily corrected. When compared to *control* subject data, these success rates were somewhat lower.

1. The 86.6 percent success rate was 13.4 percent less than the 100 percent success rate obtained by both the TMM control groups of the AFHRL Advanced Development Study, i.e., those control subjects with more than 6 months experience and those with 6 months or less experience. (These control subjects were permitted to remove and replace LRUs until a fault was isolated.)

2. The more representative 93.9 percent success rate was only 6.1 percent less than the 100 percent success rate obtained by both experienced control groups. It is a reasonable assumption that the 93.9 percent success rate would improve with experience.

These success rates of the NADC experimental subjects (using FPJPAs) compare favorably with the success rates obtained by the experimental subjects of the AFHRL Advanced Developmental Study (using FPJPAs).

1. The 86.6 percent success rate was only 2.3 percent below the 88.9 percent success rate achieved by the high aptitude inexperienced experimental subjects of the AFHRL study: The 93.9 percent success rate was 5.0 percent above the success rate of the AFHRL inexperienced subjects.

2. Although the 86.6 percent success rate was 13.4 percent below the 100 percent success rate of the high aptitude AFHRL experimental subjects with 6 months or less experience, the 93.9 percent rate is only 6.1 percent less than the 100 percent rate.

3. The 86.6 percent success rate was 9.2 percent below the 95.8 percent success rate of the high aptitude AFHRL experimental subjects with more than 6 months experience, but the 93.9 percent rate was only 1.9 percent below these highly experienced AFHRL subjects.

It can be concluded that the Navy medium aptitude "O" level subjects with only 13 weeks of JOT performed TS tasks reasonably well *with FPJPAs* when compared to Air Force high aptitude control subjects with more than 6 months experience who used TMMs and were permitted to remove and replace LRUs until a fault was corrected. These Air Force control subjects had received 36 weeks of formal theory based training prior to job assignment and are considered to be representative of experienced Navy AN/AQA-7, "O" level technicians.

So from these comparisons, it can be assumed that Navy answers to the TS aspects of the first three of the four key questions posed near the end of the preceding section would be comparable to the Air Force answers. As to question (4) however, no studies have been conducted which have produced hard data concerning the TS success with FPJPAs of either experienced or inexperienced high aptitude personnel who had received, in lieu of current conventional long theory based training, JOT similar to that used in this evaluative tryout.

#### VII. EVALUATIVE STATEMENT CONCERNING THE AN/AQA-7 FPJPAs

The results of this evaluative tryout together with the comparisons with results of other applicable studies have indicated that the FPJPAs used for this tryout were reasonably effective with medium aptitude subjects for "O" level TS problems and very effective for "I" level TS problems. Also, the fact that they worked so well in spite of the "watered down" implementations of the accompanying JOT programs speaks well for their effectiveness. But their effectiveness would have been even greater if all aspects of the FPJPA technology, as outlined in Figure 1, had been included in their development.

The technology as well as the specification and guidance found in AFHRL-TR-71-53 (Folley et al., 1971a, 1971b; Joyce et al., 1971) require that all the formal products of TI&A be reviewed and accepted by the procuring agency, in this case NADC. They, also, require that the procuring agency ensure that these products are utilized as content criteria during the development of the actual FPJPAs. Since it was the prime output for the first contract the task identification document, the TIM, received a very thorough evaluation and official acceptance. With the exception of the TIM and TS action trees, none of the other task identification and analyses (TI&A) products were subjected to these evaluation and acceptance requirements. The NADC had no inhouse capability for accomplishing these requirements or for ensuring that these TI&A products were applied as content criteria during the actual FPJPA development.

As a result of experience gained in this project it can be asserted that these assessment activities are necessary for quality FPJPAs even if the contractor has highly experienced personnel in FPJPA development. The FPJPAs would probably have been improved by such assessment activities even in this case where the contractor developing the aids had previously developed the AFHRL-TR-71-53 specification and guidance documents. Such assessment activities would, also, have given NADC advanced warning of any slippage in delivery schedules. These assessment activities during development become absolute requirements where the contractor has had no previous experience with the technology.

As stated in Figure 1, "hands on" validation and verification of the final FPJPAs are also necessary aspects of the FPJPA technology and are required for ensuring the production of quality FPJPAs. Although the Magnavox representatives were required to attest to the technical accuracy of each FPJPA, in-depth "hands on" verification procedures were applied only to the FPJPAs for those tasks used in the evaluative tryout. A number of weaknesses of omission and commission were identified. This limited verification reiterated the requirement for the review and acceptance of all products of TI&A (not just the TIM and TS trees) by the procuring agency. If these AN/AQA-7 FPJPA were to be given full scale field implementation, each aid would require a complete "hands on" verification.

As indicated in Figure 1, effective FPJPAs must reflect the maintenance concept for the level of maintenance for which they are developed. This tryout emphasized the importance of maintenance concept stability. During the development of the FPJPAs for the AN/AQA-7 systems, its "I" level maintenance concept changed. Originally "I" level maintenance was responsible for only identifying faulty integrated circuit cards, all within card repair being assigned to depot maintenance. Part of this within card responsibility was transferred to the "I" level, approximately tripling the number of "I" level trouble signatures for FPJPA, TS coverage. Because of time and R&D funding limitations, FPJPAs for these additional signatures were not developed for this project.

This is an example of the domino effect on maintenance guidance and/or training which can be produced by a change in the maintenance concept of a system. When FPJPAs and JOT are involved, the

results are immediately apparent, because of the stringent content controls required for these technologies. The effects of such drastic changes are not always immediately apparent with traditional theory based training and TMMs but the results are sometimes hidden in increased destruction of parts and secondary damage to hardware. In this case, however, added training and Navy inhouse repair facilities were required including expensive semi-automatic card test equipment. Drastic changes in maintenance concepts have such serious consequences, that any person or agency proposing such changes should be required to justify funding of the additional training and maintenance directions required to implement the changes. In the case of AN/AQA-7 FPJPAs, the necessary modification of the "I" level FPJPAs for actual field use would have required a substantial additional expenditure of funds.

#### VIII. SUMMARY AND CONCLUSIONS

1. Starting in 1972, the Human Engineering Division of the Naval Air Development Center (NADC), Warminster, Pennsylvania, supported a FPJPA/TOT tradeoff effort. Historically, this effort had its genesis in the AFHRL FPJPA/TOT tradeoff demonstration which was conducted at Altus AFB in early 1972 (see Mullien & Joyce, 1974). Whereas the Altus effort was only a demonstration, this effort was planned as a full scale controlled study to determine the relative effectiveness of the combined FPJPA and TOT technologies with respect to traditional theory based training and TMMs. Unfortunately, the controlled comparative aspects of this plan were never completed. Nevertheless, FPJPA for "O" and "I" level maintenance of the AN/AQA-7 Sonar as well as matching JOT packages (one for "O" level technicians and one for "I" level technicians) were developed and hard data as to their effectiveness were obtained.

2. The job aids for the AN/AQA-7 Sonar Recorder Group developed for this effort reflected the vintage of FPJPA technology found in the three volume technical report, AFHRL-TR-71-53 (Folley et al., 1971a, 1971b; Joyce et al., 1971). This was a substantially more advanced vintage of developmental technology than that reflected by the FPJPAs used in the Altus AFB demonstration, which were developed without the benefit of such structured guidance. The aids used at Altus AFB were limited to TS, whereas the aids developed for this effort covered non-TS tasks as well.

3. Although the results of this tryout indicated that the AN/AQA-7 aids were effective and of adequate quality, their development effort omitted some very important aspects of the specification and guidance found in AFHRL-TR-71-53. These documents require that all the formal products of the TI&A of identified tasks be reviewed and accepted by the procuring agency, in this case NADC. They, also, require that the procuring agency ensure that these products are utilized as content criteria during the development of the actual FPJPAs. The only TI&A products which received such treatment were the troubleshooting action trees. (For this specific procurement, these development omissions did not result in unsatisfactory aids. The contractor developing the aids had, also, developed the AFHRL-TR-71-53 specification and guidance documents.) In addition, due to funding and scheduling problems, all FPJPAs did not receive the required contractor validation and the government verification. Only those FPJPAs used for the experimental tryout problems received such treatment.

4. As to the JOT packages, they were substantially more complete than those developed for the Altus demonstration. For those subjects assigned to "O" level maintenance a 13-week JOT package was developed to prepare medium aptitude personnel (approximately 40 to 50 percentile) to perform "O" level maintenance on the AN/AQA-7 Sonar Recorder Group of the S2-G aircraft using FPJPAs. A 16-week JOT package was developed to prepare the same range of medium aptitude personnel to perform "I" level maintenance tasks on the same equipment using FPJPAs. These JOT packages were of good quality. However, since these packages arrived 4 weeks after training started, the subjects did not obtain the full advantage of their potential.

5. Traditionally, the AN/AQA-7 System has been maintained by "A" school graduates using TMMs. The entry aptitude for "A" school is 84 percentile and above. The appropriate "A" school program was 22 weeks in length and was theory based. Students selected for "O" level maintenance received two additional

weeks of AN/AQA-7 specific training, making the conventional training a total of 24 weeks. Students selected for "I" level maintenance received 14 additional weeks of system specific training, making the conventional training a total of 36 weeks. So the JOT package for "O" level training was 11 weeks shorter than conventional training (a 46 percent savings in training time) and the "I" level package was 20 weeks shorter than conventional training (a 56 percent savings in training time).

6. The original plan for the conduct of JOT included the following assumptions: (a) students would arrive in four groups of 10 each approximately 1 to 2 weeks apart, (b) there would be four instructors, two to teach the "I" level maintenance program and two to teach the "O" level maintenance program, (c) two AN/AQA-7 systems and two AN/AQM-18 test benches could be made available for the exclusive use of the project, and (d) access to S2G aircraft (with operating AQA-7s) could be obtained. Unfortunately, none of these conditions were met, the students arrived early and all within a single 10-day period, only three instructors could be recruited, only one AN/AQA-7 and AN/AQM-18 could be provided, and access to S2G aircraft was limited due to heavy flight commitments of the operational forces. Finally, as mentioned previously, the JOT training materials were delivered approximately one month late and not properly collated. After delivery and assembly of the training materials, the 41 trainees were divided into three sections: two sections of 13 trainees each were assigned to "I" level training and one section of 15 trainees was assigned to "O" level training. Three "O" level and three "I" level subjects were dismissed from the program for non-academic reasons.

7. For this evaluative tryout, a concerted effort was made to provide a realistic and practicable work setting with representative maintenance problems. Since the data collection had to be accomplished in 4 weeks, only five problems could be scheduled for each "O" level subject and only four for each "I" level subject. However, the problems selected are considered representative. The results of performance of subjects concerning the "O" and "I" level maintenance problems are displayed in Tables 1 and 2, respectively. Their composite success on "O" level problems was 86.6 percent and on "I" level problems was 82.5. All the "O" level problems concerned TS. On their two TS problems, the "I" level subjects obtained an 89.1 percent rate.

8. These results reinforce the results of other DoD Job Performance Aid R&D. They also provide important additional data. The results are comparable to and complement those reported for the AFHRL Advanced Development Study (Potter & Thomas, 1976). In this AFHRL study, which considered only TS problems, the inexperienced subjects isolated approximately 89 percent of both "O" and "I" level troubles (see Tables 3 and 4). It should be noted that this AFHRL study utilized high aptitude subjects (80 percentile and above), who had completed 36 weeks of conventional theory based training, *whereas* this evaluative tryout utilized only medium aptitude subjects (40 to 50 percentile) who had completed either 13 or 16 weeks of JOT.

9. The "I" level TS success rate of approximately 89 percent obtained both by these *inexperienced*, medium aptitude, Navy subjects and by the *inexperienced*, high aptitude Air Force subjects is very impressive when compared to available control data. The control subjects with *more than 6 months experience* of the AFHRL Advanced Development solved 78.8 percent of their "I" level TS problems when using TMMs and the control subjects with *6 months or less experience* solved only 60.6 percent. These AFHRL control subjects were high aptitude subjects who had received at least 36 weeks of conventional theory based training.

10. Although less dramatic, the "O" level TS results obtained by these inexperienced Navy and Air Force subjects are quite good when compared to the available control data. These Navy medium aptitude subjects using FPJPA, obtained a composite success rate of 86.6 percent (see Table 3). If the problem requiring the use of the dual beam feature of the oscilloscope is excluded, this rate is 93.9 percent. The Air Force *inexperienced subjects* using FPJPAs obtained a composite rate of 88.9 percent. Although the experienced Air Force control subjects obtained 100 percent success rates when using TMMs, they were permitted to remove and replace components until the troubles were found, whereas inexperienced experimental subjects using FPJPAs were not.

11. The subjects of this Navy study as well as those in the AFHRL Advanced Development Study (Potter & Thomas, 1976) and the Altus AFB demonstration (Mullen & Joyce, 1974) displayed weaknesses in their ability to use key test equipments, especially the oscilloscope. The percentages of troubles successfully found, although impressive, would no doubt have been higher if subjects had possessed high proficiency in the use of their test equipment. (There is also substantial evidence that the inability to adequately use oscilloscopes is a common weakness of many DoD experienced maintenance technicians (Foley, 1975).)

12. This project demonstrated the feasibility of combining the FPJPA and JOT technologies and that such a combination would reduce initial training time for first term maintenance personnel. In spite of all the difficulties previously mentioned, the performance of the medium aptitude subjects of this Navy evaluative tryout was impressive when compared to available control data. Their performances using FPJPAs were as good or better than the performances of high aptitude, conventionally trained subjects using TMMs in other studies. All of the mentioned difficulties are correctable and their correction would result in still higher levels of performance.

13. So, the combined implementation of the FPJPA and JOT technologies would result in three major benefits to the Navy. It would greatly reduce the training time required for first enlistment maintenance personnel; thus, increasing their on-the-job time. It would, also, permit the training of medium aptitude personnel, in addition, to the currently utilized, high aptitude personnel now required for the long traditional theory based training. *And* while providing these impressive personnel benefits, it would increase the efficiency of the performance of maintenance including a substantial reduction in spare parts usage. The realization of these benefits however requires the quality implementation of these technologies under the direction of personnel with successful experience in their applications. To do otherwise, will invite "watered down" implementation followed by "watered down," if not disastrous, field results.

#### Lessons Learned

1. This evaluative tryout reiterates findings of other FPJPA studies that the effectiveness of quality FPJPAs can be substantially degraded by users' inability to use their test equipments proficiently. In all future applications of FPJPAs, appropriate actions must be taken to assure that FPJPA users can employ their test equipment accurately.

2. Although in-depth "hands on" verification procedures were only applied to FPJPAs for those tasks used in the evaluation, a number of weaknesses of omission and commission were identified. This partial verification reiterated the requirement for the review and acceptance of all products of TI&A (not just TS trees) by the procuring agency. The procuring agency must also ensure that the appropriate TI&A products are used as criteria for content control during FPJPA development. And these assessment activities are necessary for quality FPJPAs even if the contractor has highly experienced personnel in FPJPA development. (These necessary activities require that the procuring activity have personnel with the necessary skills.) As stated in Figure 1, these activities, together with validation and verification of the final FPJPAs, are all part of the FPJPA technology and are necessary activities for ensuring the production of quality FPJPAs.

3. During the development of the FPJPAs for the AN/AQA-7 systems, its "I" level maintenance concept changed. Originally "I" level maintenance was responsible for only identifying faulty integrated circuit cards, all within-card repair being assigned to depot maintenance. Part of this within-card repair responsibility was transferred to the "I" level, approximately tripling the number of "I" level trouble signatures for FPJPA, TS coverage. Because of time and R&D funding limitations, FPJPAs for these additional signatures were not developed for this project. This is an example of the domino effect on maintenance guidance and/or training which can be produced by a change in the maintenance concept of a system. When FPJPAs and JOT are involved, the results are immediately apparent, because of the stringent content controls required for these technologies. Although the effects of such a drastic change in maintenance concept are not as immediately apparent with traditional theory based training and TMMs, the results no doubt are hidden in increased destruction of parts and costly secondary damage to hardware—in this case, to expensive integrated circuit cards.

**Suggestions for Future Applications**

Program managers and system acquisition personnel charged with procurement of technical manuals and training systems can no longer ignore the enormous benefits possible through the application of the JPA/JOT technologies. Even experienced, traditionally trained personnel are more content and effective with clearly and simply written maintenance instructions.

In order to gain maximum benefit from the JPA/JOT technology, a large portion of maintenance instructions must be developed using JPA technology. When a sufficient body of technical data for a specific weapon system or a selected rate (job code) has been developed it will be possible to start changing over from long, theory-oriented basic schools such as the Navy "A" schools to direct inputs to job-oriented training such as now exist at Navy readiness squadrons under the Fleet Readiness Aviation Maintenance Program (FRAMP) and to a certain extent at the Naval Aviation Maintenance Training Detachments (NAMTRADETS). These training elements now provide weapon system specific training which however assumes a theoretical base established at the Navy "A" schools.

Therefore, it is recommended that the JPA/JOT technology be applied to all training and technical data bought to support new acquisitions, or major modification to existing equipment. The JOT can be incorporated into the NAMTRADET and FRAMP curricula and when a sufficient body of technical data has been transformed into JPA format maintainees can be ordered directly from recruit training to weapon system specific JOT.

### ACKNOWLEDGEMENTS

While the senior author must bear fully the responsibility for any weaknesses or errors which this work may contain, the credit for any success which may have been attained must be shared with the many persons who directly or indirectly contributed to its success.

The trust and support of the Commander Naval Air Development Center—Captain H. McCauley—was the beginning step without which the study could not have been initiated. Without the sustaining advice, support, and encouragement of the Weapons Training Division—especially Mr. Irwin May, Mr. Barry Holt, and Mr. Dean Jones—the project could never have been initiated or completed.

VADM Cagle, Chief of Navy Education and Training, endorsed the program as one possible way to reduce soaring training costs, while RADM Sackett, Chief of Navy Technical Training, enthusiastically challenged the research team to find a way to reduce the need for "A" schools.

The project found its most ardent support at the Bureau of Naval Personnel where VADM G. E. Kinnear II helped in the assignment of the forty-one experimental trainees and linked the study to the Navy Enlisted Occupation Program Director, RADM R. G. Freeman, to conduct a comprehensive look at the Navy Enlisted Personnel System.

The report mentions the generous support received from the operational units without whose daily working support the study could not have been accomplished. However, I must add Ms. Joann Wright and Ms. Jane Campbell, project team members, whose unstinting efforts at data collection and myriad other tasks carried the project in its 24 hour a day schedule.

Finally, I must mention the all pervasive influence of Dr. John Foley of the Advanced Systems Division, Air Force Human Resources Laboratory and Dr. Jack Folley of Applied Science Associates, Inc., probably the most influential men in my encounter with JPA/JOT and who both provided frequent counsel in the conduct of the study.

## REFERENCES

- Applied Science Associates, Inc. *Handbook for development of advanced job performance aids (JPA) in accordance with MIL-J-83302*. AD-716 820. Wright-Patterson AFB, OH: Aeronautical Systems Division, Air Force Systems Command, January 1971. (a)
- Applied Science Associates, Inc. *Handbook for JPA managers on review and assessment of advanced-type job performance aids prepared to MIL-J-83302*. Wright-Patterson AFB, OH: Aeronautical Systems Division, Air Force Systems Command, August 1971. (b)
- Elliott, T.K. *The effect of electronic aptitude on performance of proceduralized troubleshooting tasks*. AMRL-TR-67-154, AD-664 889. Wright-Patterson AFB, OH: Aerospace Medical Research Laboratory, November 1967.
- Elliott, T.K., & Joyce, R.P. *An experimental comparison of procedural and conventional electronic troubleshooting*. AFHRL-TR-68-1, AD-681 510. Wright-Patterson AFB, OH: Training Research Division, Air Force Human Resources Laboratory, November 1968.
- Foley, J.P., Jr. *Criterion referenced measures of technical proficiency in maintenance activities*. AFHRL-TR-75-61, AD-A016 420. Wright-Patterson AFB, OH: Advanced Systems Division, Air Force Human Resources Laboratory, October 1975.
- Foley, J.P., Jr. *Executive summary concerning the impact of advanced maintenance data and task oriented training technologies on maintenance, personnel, and training systems*. AFHRL-TR-78-24, AD-A053 682. Wright-Patterson AFB, OH: Advanced Systems Division, Air Force Human Resources Laboratory, March 1978. (a)
- Foley, J.P., Jr. *Impact of advanced maintenance data and task oriented training technologies on maintenance, personnel and training systems*. AFHRL-TR-78-25. Wright-Patterson AFB, OH: Advanced Systems Division, Air Force Human Resources Laboratory, September 1978. (b)
- Folley, J.D., Jr., Joyce, R.P., Mallory, W.J., & Thomas, D.L. *Fully proceduralized job performance aids: Volume I - Draft specification for organizational maintenance*. AFHRL-TR-71-53(I), AD-740 903. Wright-Patterson AFB, OH: Advanced Systems Division, Air Force Human Resources Laboratory, December 1971. (a)
- Folley, J.D., Jr., Joyce, R.P., Mallory, W.J., & Thomas, D.L. *Fully proceduralized job performance aids: Volume II - Developer's handbook*. AFHRL-TR-71-53(II), AD-744 004. Wright-Patterson AFB, OH: Advanced Systems Division, Air Force Human Resources Laboratory, December 1971. (b)
- Joyce, R.P., Chenzoff, A.P., Mulligan, J.R., & Mallory, W.J. *Fully proceduralized job performance aids: Volume I - Draft military specification for organizational and intermediate maintenance*. AFHRL-TR-73-43(I), AD-775 702. Wright-Patterson AFB, OH: Advanced Systems Division, Air Force Human Resources Laboratory, December 1973. (a)
- Joyce, R.P., Chenzoff, A.P., Mulligan, J.F., & Mallory, W.J. *Fully proceduralized job performance aids: Volume II - Handbook for JPA developers*. AFHRL-TR-73-43(II), AD-775 705. Wright-Patterson AFB, OH: Advanced Systems Division, Air Force Human Resources Laboratory, December 1973. (b)
- Joyce, R.P., Chenzoff, A.P., Mulligan, J.F., & Mallory, W.J. *Fully proceduralized job performance aids: Volume III - Handbook for JPA managers and training specialists*. AFHRL-TR-73-43(III), AD-775 706. Wright-Patterson AFB, OH: Advanced Systems Division, Air Force Human Resources Laboratory, December 1973. (c)
- Joyce, R.P., Folley, J.D., Jr., & Elliott, T.K. *Fully proceduralized job performance aids: Volume III - JPA manager's handbook*. AFHRL-TR-71-53(III), AD-744 817. Wright-Patterson AFB, OH: Advanced Systems Division, Air Force Human Resources Laboratory, December 1971.

- Mil-J-83302 (USAF). *Military specifications, job performance aids, advanced type, for VNAF organizational maintenance*. January 1971.
- Mullen, P.A., & Joyce, R.P. *Demonstration of fully proceduralized job performance aids and matching training*. AFHRL-TR-74-69, AD-A002 147. Wright-Patterson AFB, OH: Advanced Systems Division, Air Force Human Resources Laboratory, August 1974.
- Pieper, W.J., Swezey, R.W., & Valverde, H.H. *Learner-centered instruction (LCI), Volume VII. Evaluation of the LCI approach*. AFHRL-TR-70-1(VII), AD-713 111. Wright-Patterson AFB, OH: Training Research Division, Air Force Human Resources Laboratory, February 1970.
- Potter, N.R., & Thomas, D.L. *Evaluation of three types of technical data for troubleshooting: Results and project summary*. AFHRL-TR-76-74(I), AD-A035 303. Wright-Patterson AFB, OH: Advanced Systems Division, Air Force Human Resources Laboratory, September 1976.
- Rowan, T.C. *Improving DoD maintenance through better performance aids*. ARPA Order Number 2244. Washington, DC: Advanced Research Project Agency, March 1973.
- Serendipity, Inc. *Project PIMO final report*. TR-69-155, Volume I, AD-852 101. Norton AFB, CA: Space and Missile Systems Organization, Air Force Systems Command, May 1969.
- Shriver, E.L. *Fully proceduralized job performance aids: Guidance for performing behavioral analyses of tasks*. AFHRL-TR-75-38, AD-A015 059. Wright-Patterson AFB, OH: Advanced Systems Division, Air Force Human Resources Laboratory, June 1975.

REFERENCE NOTES

- 1 Post, T.S., & Brooks, F.A. *Advanced manpower concepts for sea-based aviation systems (AMSAS)*. Washington, DC: Advanced Systems Concept Division, Research and Technology Group, Naval Air Systems Command. Unpublished manuscript, 1970. (Available from T.J. Post, Biotechnology, Inc., 3027 Rosemary Lane, Falls Church, VA 22042, telephone (703) 573-3700).
- 2 Horn, L. *Job performance aids test*. Washington, DC: Naval Weapons Engineering Support Activity, Washington Navy Yard. Unpublished manuscript, 1972. (Available from Leon Horn, Washington Navy Yard, Washington, DC 20390, telephone (202) 433-2789).

NADC-78286-60

*APPENDIX A.* DESCRIPTION OF THE DEVELOPMENTAL PROCESS FOR AN/AQA-7  
FULLY PROCEDURALIZED JOB PERFORMANCE AIDS

By

Thomas K. Elliott  
Applied Science Associates, Inc.  
Valencia, Pennsylvania

Introduction

This appendix describes the process by which the integrated development of JPA\* and training was accomplished. The process description is heavily supported with examples of actual experimental materials from the AN-AQA-7 JPA and Course, and with intermediate products used in their development. Complete files of intermediate and final products reside at the office of CDR Charles J. Theisen, Jr.,<sup>1</sup>Head, Training Branch (4024), Naval Air Development Center, Warminster, Pennsylvania 18974. Because the process of JPA development is controlled by specification and has been described in great detail elsewhere, the focus of this appendix is on process features employed for the first time here, and on unique aspects of this effort. In general, the process followed is outlined in detail in AFHRL-TR-71-53 (Folley et al, 1971a; 1971b; & Joyce et al, 1971).

Figure A-1 schematizes the relations among major development efforts.

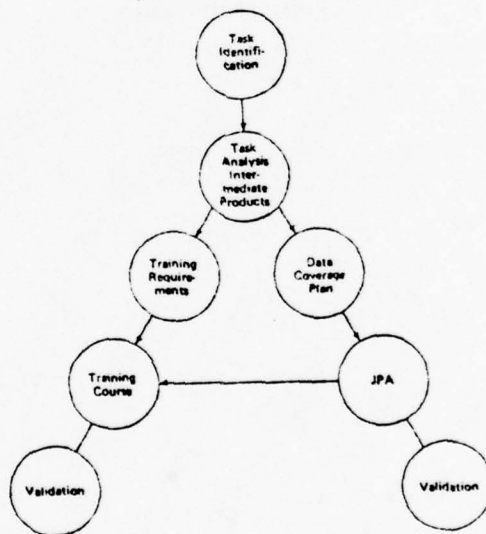

Figure A-1. The Development of JPA and Training Materials

\*Job Performance Aids.

<sup>1</sup>Now Commanding Officer, Naval Hospital Corps School, Great Lakes, IL.

First, maintenance tasks to be performed were identified and analyzed. This analysis resulted in task analysis intermediate products, documents descriptive of the audience, his tasks, tools, equipment, etc., and in lists of nouns and verbs to be used in the program, and a writing style guide. Behavioral Scientists decided which tasks were best covered in training and which by the JPA. This analysis resulted in a data coverage plan and a set of training requirements. Finally, the training and JPA were prepared and validated.

Task Identification Matrix

The Task Identification Matrix (TIM) is as described in AFHRL-TR-71-53 except that the maintenance function codes have been modified as follows:

X codes indicate maintenance-significant components.

A hardware item with an X code must be considered a maintenance-significant part of the next superordinate T entry in the same column. In the case of a troubleshooting T, each subordinate X must be found by the troubleshooting as a cause of malfunction. Each subordinate, X-coded, piece-part shall be considered a "Component" in the List of Components (AFHRL-TR-71-53, para 3.4.5a). All subordinate X-coded components join to form a definitive list of the end items associated with a particular troubleshoot task.

Subscript codes indicate level of maintenance or maintenance activity.

0 = Organizational Maintenance

I = First level Intermediate maintenance; refer to Figure A-2 (AQA-7 Data Coverage Plan). All checkout and troubleshoot tasks directly subordinate to Organizational maintenance are coded with the subscript I; thus, their subordinate components are coded  $X_I$ .

$I_1$  = Second level Intermediate maintenance procedures to which the user would be referred from the first level procedures.

QA-7 DATA COVERAGE PLAN

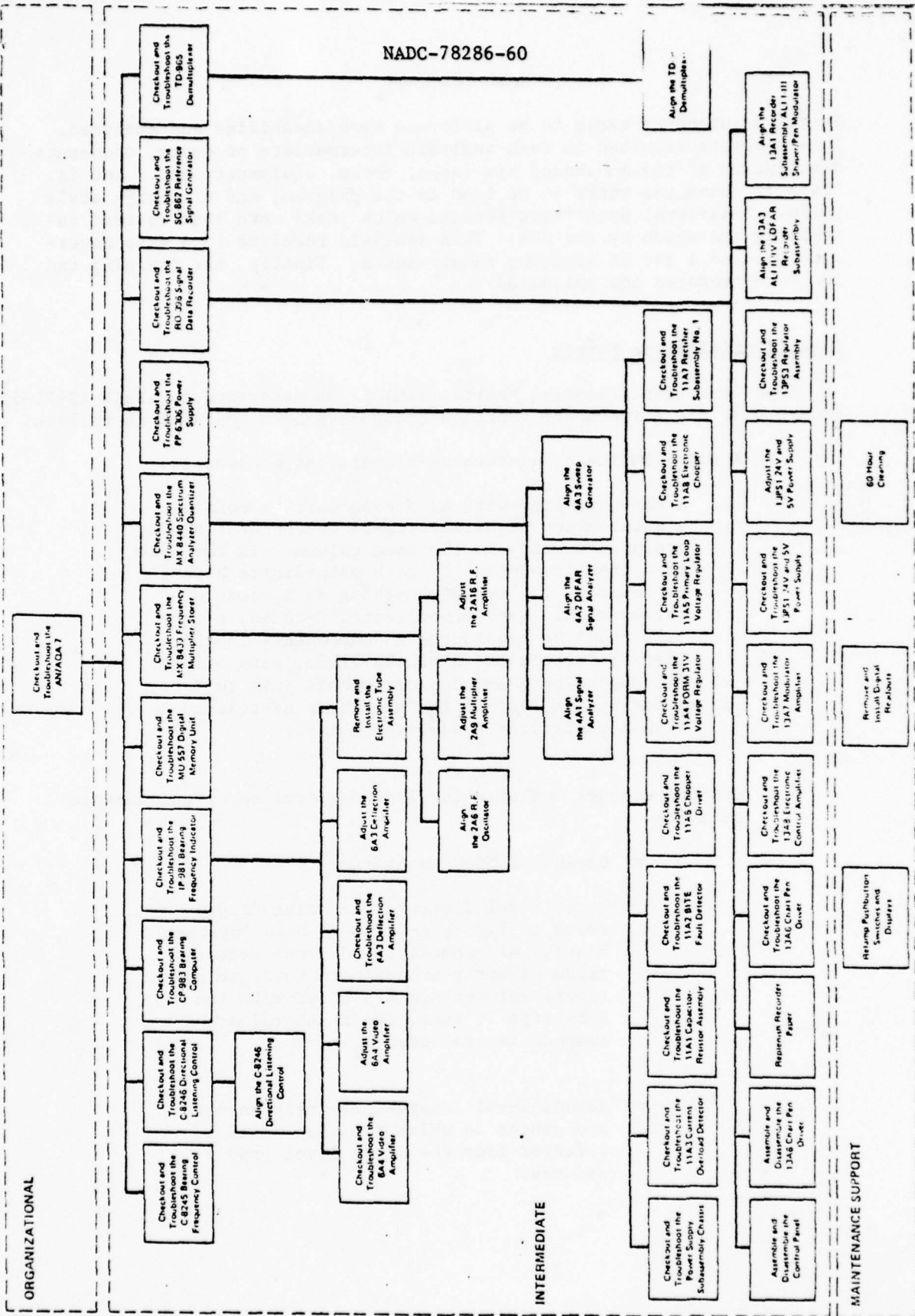

Rev 17 Aug 1973

Figure A-2. QA-7 Data Coverage Plan

Special Notes:

1. A section in the Maintenance Support Information Manual (MSIM) will be included to cover relamping all of the back-lighted pushbutton switches and similarly styled indicators. The components of these assemblies are indicated in the TIM by the symbol ①. Although there are many of these assemblies referenced, they are so similar that one MSIM section will cover all of them.
2. A section will also be included in the MSIM to cover removal and replacement of all digital readouts. These components are indicated by the symbol ② in the TIM.
3. A section will also be included in the MSIM to cover all 60-hour cleaning tasks.
4. Components in italics are included to preserve generation breakdown.

Two example TIM pages follow (Figure A-3).

Task Analysis Intermediate  
Products

Task analysis intermediate products include the Task-Step Data Details (TSDD), the Generic Noun List, the Test Equipment and Tool Use Forms (TETUF), the Task Inventory, and a Style Guide. These documents provide additional clarification, guidance, and control for task analysis considerations and JPA writing. Examples of these documents follow (Figures A-4 through A-8).

System Hardware Levels		Maintenance Functions	Reference Designator	Notes	Adjust	Align	Calibrate	Checkout	Handle	Inspect	Install	Operate	Remove	Repair	Service	Troubleshoot
1		AN/AQA-7(V) Type III Sonar Computer-Recorder Group			0	0	0	T <sub>0</sub>	0	0	0	0	0	0	0	T <sub>0</sub>
1	1	Bearing Frequency Control C-8245	7	709575-801	0	0	0	T <sub>I</sub>	0	0	0	0	0	0	0	X <sub>0</sub> T <sub>I</sub>
1	1	Bearing Frequency Control Subassembly	7A11	718508-801	0	0	0	0	0	0	0	0	0	0	0	X <sub>I</sub>
1	1	Bearing Frequency Control Subassembly	7A10	718430-801	0	0	0	0	0	0	0	0	0	0	0	X <sub>I</sub>
1	1	Bearing Frequency Control Subassembly	7A9	718430-801	0	0	0	0	0	0	0	0	0	0	0	X <sub>I</sub>
1	1	Bearing Frequency Control Subassembly	7A8	718430-801	0	0	0	0	0	0	0	0	0	0	0	X <sub>I</sub>
1	1	Bearing Frequency Control Subassembly	7A7	718430-801	0	0	0	0	0	0	0	0	0	0	0	X <sub>I</sub>
1	1	Screw		D7500-6A3	0	0	0	0	0	0	0	0	0	0	0	0
1	1	Bearing Frequency Control Subassembly Chassis		718431-801	0	0	0	0	0	0	0	0	0	0	0	0
1	1	Lens, Switch, Push		680923E4-1	0	0	0	0	0	0	0	0	0	0	0	0
1	1	Lens, Switch, Push		680923E4-1	0	0	0	0	0	0	0	0	0	0	0	0
1	1	Switch, PB	7DS1	680923E12-2	0	0	0	0	0	0	1	0	1	0	0	X <sub>I</sub>

System Hardware Levels				Maintenance Functions				Reference Designator	Notes	Adjust	Align	Calibrate	Checkout	Handle	Inspect	Install	Operate	Remove	Repair	Service	Troubleshoot
1174				Switch, PB	7DS2	680923E12-2		0	0	0	0	0	0	0	0	0	0	0	0	0	X <sub>I</sub>
1175				Readout, Digital	7DS4	1000		0	0	0	0	0	0	0	0	0	0	0	0	0	X <sub>I</sub>
1176				Readout, Digital	7DS5	1000		0	0	0	0	0	0	0	0	0	0	0	0	0	X <sub>I</sub>
1177				Readout, Digital	7DS6	1000		0	0	0	0	0	0	0	0	0	0	0	0	0	X <sub>I</sub>
1178				Readout, Digital	7DS7	1000		0	0	0	0	0	0	0	0	0	0	0	0	0	X <sub>I</sub>
1179				Switch, Push	7A6	680923E12-4		0	0	0	0	0	0	0	0	0	0	0	0	0	0
11791				Lens, Push, Switch		680923E4-46		0	0	0	0	0	0	0	0	0	0	0	0	0	0
11792				Switch, Push	7A6S2	680923E6		0	0	0	0	0	0	0	0	0	0	0	0	0	X <sub>I</sub>
11793				Lens, Push, Switch		680923E4-45		0	0	0	0	0	0	0	0	0	0	0	0	0	0
11794				Switch, Push	7A6S1	680923E5		0	0	0	0	0	0	0	0	0	0	0	0	0	X <sub>I</sub>
1170				Switch, Push	7A5	680923E12-4		0	0	0	0	0	0	0	0	0	0	0	0	0	0
11701				Lens, Push, Switch		680923E4-46		0	0	0	0	0	0	0	0	0	0	0	0	0	0

AN/AQA-7 FPJPA TASK-STEP DATA DETAILS (TSDD)

1. DISCRIMINATIONS AND PERCEPTIONS CRITICAL TO SUCCESSFUL TASK PERFORMANCE

a. Observing Gross Indications. The task step should name the indicator and will state the condition to be observed (for example, a light on or off; a motor running or not running). The illustration will depict the indicator's location; wherever practical and necessary to communicate an instruction, the illustration will also show the state of the indicator.

Training will provide knowledge of the physical context of indicators.

b. Reading Quantitative Values. The task step will state a range of acceptable values by naming the inclusive limits of the range. The location of the indicator (scale, counter) will be illustrated (with the exception of some common pieces of test equipment--see the Test Equipment and Tool Use Form). Counter readings will not be illustrated. Necessary scale reading and interpolation skills are assumed to be present in the user. These skills will be developed in a specific segment of the training program.

c. Noting Relative Motion. When relative motion is an important cue, the task step will describe the relevant dimensions of motion (direction and/or rate) of objects with respect to one another, and will include a statement of the observer's position relative to the objects whenever his position is necessary for correct interpretation of the text (e.g., a fan rotating clockwise when viewed from the front). Illustration of the moving components will indicate the direction of motion with the use of an arrow pointing from each object along its path of motion.

Training will provide practice using task steps utilizing motion symbology.

d. Reading or Interpreting Oscilloscope Patterns or Waveforms. The task step text will require the technician to compare his display with a standard provided in the illustration. The illustration will be a white-on-black rendering of the nominal expected display, with the frequency, amplitude, and/or shape tolerance range indicated with dimension lines, and a statement of the tolerance (e.g., "greater than 10 divisions").

Training will provide exposure to typical waveform and tolerance displays. Practice sessions using the oscilloscope will also utilize FPJPA waveform presentation techniques to provide practice reading and interpreting waveforms.

Figure A-4. Task-Step Data  
Details (TSDD)

e. Noting Visually Detectable Physical Defects. The task step will instruct the technician to visually inspect an object and will name specific defects to look for (e.g., scored cylinder walls, deteriorated "O" ring, charred insulation, or change in color of an object).

Training will provide exposure to samples of hardware containing defects of the type requiring detection by the manuals. Trainees must demonstrate the ability to describe and detect all visually detectable malfunctions mentioned in the FPJPAs.

f. Presence or Absence of Sounds and Vibrations. Sounds and vibrations will be used only as gross indicators. The task step will ask only that the technician note presence or absence of a sound or vibration and will tell him where to direct his attention. No discriminations of loudness of sound or of amplitude of vibration will be required. The illustration will depict the location of the source of the sound or vibration.

Training will provide exposure to normal operation sounds.

g. Discrimination of Pitch or Other Characteristics of a Sound. Absolute pitch judgments will not be required; but if a tone can sweep through a range of frequencies, the technician may be required to observe whether the pitch increases or decreases. The technician will be required to discriminate only presence or absence of other sound characteristics.

h. Discrimination of Odors. No olfactory discriminations will be required of the FPJPA user.

## 2. PROBLEM-SOLVING AND DECISION-MAKING CRITICAL TO SUCCESSFUL TASK PERFORMANCE

a. Selection of Appropriate Next Step or Task. The task steps will always follow each other in numerical order. References to other steps or tasks will provide sufficient information to proceed directly to the referenced material, in accordance with para. 3.3.7.3 of AFHRL-TR-71-53, Vol. I.

b. Performing Calculations. Any problems requiring mathematical sophistication beyond simple addition and subtraction will be reduced to these simple operations, or will be aided by a nomogram or tabular presentation of data.

Training will provide practice in performing simple calculations and using nomograms or tables specifically used in the FPJPAs.

c. Exercising Judgment. FPJPA users will be required to exercise judgment to recognize a visually detectable malfunction, including those introduced by the technician during repairs.

Figure A-4. Task-Step Data Details (TSDD)  
(cont.)

d. Translating or Converting Data Forms. When conversions from one data form to another are required (e.g., Fahrenheit to Centigrade, octal to decimal, degrees to radians), tabular or graphic conversion aids will be provided in the MSIM. When such tabular or graphic conversion aids are provided, they will be accompanied by detailed instructions for their use, including examples if necessary.

### 3. MOTOR ACTIONS CRITICAL TO TASK PERFORMANCE

a. Activating Binary Switches. The task step will name the control and the position to which it is to be set. The illustration will depict the location of the switch, but the user must depend upon the text for position (setting) information.

The training program will provide practice experiences for locating and operating all system front panel controls.

b. Adjusting Continuous Controls to Specified Setting. The task step will name the control and specify the direction of operation (e.g., clockwise, to the left). The step will also name the value to be set and the indicator upon which the value is to be read (e.g., turn IF GAIN control clockwise until M01 reads 0.5 volts). Whenever a peak or null indication is expected, that condition will be so stated, with the assumption that the user knows how to recognize it (e.g., adjust TUNE control until null is observed on M01). The illustration will depict the locations of controls and displays.

c. Setting a Multiposition Control to a Specified Setting. The task step will name the control and the position to which it must be set. The illustration will depict the location of the control, but the user must depend on the text for the setting information.

d. Performing Coordinated Gross Body Movements. The task steps will describe movements and body positions necessary to move or position hardware items. Appropriate Human Engineering guides will be consulted to assure that all required moving, lifting, and reading operations are within the user's capabilities.

### 4. READING LEVEL AND READING COMPREHENSION CRITICAL TO TASK PERFORMANCE

a. Sentence Length. Task statements will contain no more than three sentences. Each sentence will contain 10 words or less (refer to AFHRL-TR-71-53, para 3.3.7.3.L).

b. Word Length. Language of the task statements (other than hardware-specific nomenclature and placarded information) will be as simple as possible. Syllable counts will be performed on random page samples excluding hardware-specific and placarded terms; 150 syllables/one-hundred words will be the goal.

Figure A-4. Task-Step Data Details (TSDD)  
(cont.)

c. Vocabulary. The vocabulary used in the FPJPAs will come from lists of standard verbs, common (generic) nouns, and hardware-specific nouns.

Since reading level is a function of vocabulary difficulty, the standard lists will be combined to form either a Maintenance Support Information Manual section (glossary) or a training handout. In either case, training shall be expected to devote some time directly to hardware-specific terminology in addition to placarded terms, and properly use the verbs and generic nouns as a matter of course during training and in training materials. Training will provide familiarity with terminology in context, task step presentation format, and symbology utilized.

- 1) Verb List. The verb list in AFHRL-TR-71-53, para 6-2, shall be considered the official source of verbs (331 verbs). This list may be modified to include new verbs as a clear and definite need arises. (Six verbs were added for the AN-AQA-7 FPJPAs.)
- 2) Generic Nouns. The generic noun list shall be considered the official source and is modifiable as in 1) above. (The list for the AN-AQA-7 FPJPAs included 82 nouns.)
3. Hardware System-Specific Nouns. The approved Task Identification Matrix (TIM) shall serve as the official source of hardware-specific nouns.
4. Placarded Information. When control panel placarding groups controls functionally as well as uniquely identifying each control, the general level placarding shall be omitted.
5. Standard Statements. Standard forms will be used where the individual task steps are very similar (e.g., each use of a particular piece of test equipment is the same except for expected reading, point of test, and reference if test is failed). Each occurrence of a similar event will be written the same except for the unique variable information.

Figure A-4. Task-Step Data Details (TSDD)  
(cont.)

SYNONYMS BY ORDER  
OF PREFERENCE

EXAMPLE

DEFINITION

NOUN

Focus	The sharp, clear definition of the electron beam in television or radar receivers.	Adjust the focus control.	
Frame	Major structural component of an electronic assembly.	Connect ground wire to equipment frame.	2. Chassis 3. Drawer 4. Drawer assembly
Fuse	A protective device that breaks a circuit when the current exceeds a preset value.	Replace fuse F1 with a new one.	
Fuseholder	An insulated base or capsule on which fuses are mounted.	Ref.	2. Fuse block
Generator	A device that converts mechanical energy into electrical energy.	Connect the cable to the SKW generator.	
Ground	Electrical neutral, usually connected to equipment frames to prevent shock hazards.	Connect the common test lead to ground.	2. Common 3. Chassis ground
Hunting	An undesirable oscillation of an automatic control system where the controlled variable swings on both side of the predetermined reference.	Ref.	
Idler Pulley	A pulley used for tightening a belt or for changing its direction.	Ref.	
Insulation	A nonconducting material that prevents accidental contact between unrelated conductors.	Ref.	
Interlock	A switch used as a personnel protective device, to de-energize a unit when it is opened.	Manually activate the interlock.	

NADC-78286-60

## TEST EQUIPMENT AND TOOL USE FORM

Name and Number of Item	Functions	Information to be Included in JPA	Information to be Given in Training
Digital Frequency Synthesizer, Model 3100A	Generates and/or sweeps frequencies from 0.01 Hz to 1.3 MHz.	<p>1. The user will be told where to connect the output and which output is to be used; e.g., connect -20dbm 50 <math>\Omega</math> output to _____ ( ). The input location will be illustrated.</p> <p>2. Switch setting information will be supplied for the MODE switch; e.g., set MODE switch ( ) to _____.</p> <p>3. When VARIABLE 50 <math>\Omega</math> output is used, switch setting information will be supplied for the DC OFFSET, VERNIER, and dbm; e.g., a) Set DC OFFSET to _____. b) Set VERNIER to _____. c) Set dbm to _____.</p> <p>4. When variable DECADE is used, setting information will be supplied for the DECADE SELECT, DRIVE SELECT, and ATTENUATOR: e.g., a) Set DECADE SELECT to _____. b) Set DRIVE SELECT to _____. c) Rotate ATTENUATOR control counterclockwise until _____.</p>	<p>1. Recognition of equipment by sight when specified by name.</p> <p>2. How to set up equipment ready for tests.</p> <p>3. Practice making tests using the equipment:</p> <p>finding and setting switches</p> <p>locating and making connections</p>

Figure A-6. Example Test Equipment and Tool Use Form (TETUF)

AN/AQA-7 TASK INVENTORY

1. Checkout and Troubleshoot the AN/AQA-7
  - A. Checkout and Troubleshoot the Bearing Frequency Control, C-8245
  - B. Checkout and Troubleshoot the Directional Listening Control, C-8246
    1. Align the Directional Listening Control, C-8246
  - C. Checkout and Troubleshoot the Bearing Computer, CP-983
  - D. Checkout and Troubleshoot the Bearing Frequency Indicator, IP-981
    1. Checkout and Troubleshoot the Video Amplifier
    2. Adjust the Video Amplifier
    3. Checkout and Troubleshoot the Deflection Amplifier
    4. Adjust the Deflection Amplifier
  - E. Checkout and Troubleshoot the Digital Memory Unit
  - F. Checkout and Troubleshoot the Frequency Multiplier-Storer
    1. Align the R.F. Oscillator
    2. Adjust the Multiplier Amplifier
    3. Adjust the R.F. Amplifier
  - G. Checkout and Troubleshoot the Spectrum Analyzer-Quantizer
    1. Align the Signal Analyzer
    2. Align the Signal Analyzer-DIFAR
    3. Align the Sweep Generator

Figure A-7. Page from Task Inventory

## AN/AQA-7 FPJPA STYLE GUIDE

1. Be consistent with the level of accuracy: The case is 2.75 inches by 6.50 inches by 10.54 inches.
2. Always precede the decimal point with a zero in expressions less than unity: 0.056 volt ac.
3. Panel-mounted tip jacks shall be designated as test jacks; multipin jacks and plugs shall be designated as either jacks or plugs.
4. When referring to a pin on a multipin connector, separate the connector number from the pin designation by a hyphen (J5-F, J6-4, PS-F, P6-4).
5. Access doors and panels are opened or closed.
6. Covers are removed or reinstalled.
7. Drawers are opened or closed.
8. Fasteners and latches are secured or released.
9. Nuts and bolts are tightened; when required, they are tightened to a specific torque. (Tighten nut to 500 pound-inches torque.)
10. Screws are installed or removed.
11. Components are removed or installed; replace a component or part if a new or repaired one is to be installed.
12. Brakes are set or released.
13. Auxiliary equipment is connected to test jacks, filler valves, etc.
14. Pressure is applied to ports, valves, cylinders, etc.
15. Output or input is applied or measured between test jacks, test points, etc.
16. Meters and dials indicate. (They do not read.)
17. Circuit breakers are opened and closed, and set or reset.
18. Rotary and toggle switches are set to a position. (Set power switch to ON.)
19. Pushbutton switches are depressed and released. Momentarily depress self-test switch. Depress and hold self-test switch. Release self-test switch.)

Figure A-8. Page from Style Guide

JPA Development

Introduction

One unique feature of development in the AQA-7 JPA effort was computerization of substantial parts of the work. This was done for reasons outlined below.

The traditional JPA development/production process is long and intricate, and every activity along the way is performed by humans. Some activities call for tedious cross-checking and comparison, and making sure the right numbers are entered in the right places. The process takes a lot of time, and has many opportunities for errors and oversights. It requires tremendous coordination of human activities. After carefully studying JPA processes and problems, computer experts decided that four steps in the process were particularly amenable to computer assistance:

1. Development of Action Trees. This is a slow, difficult job, complicated by a great deal of repetitive writing and referencing. Performed simultaneously by several analyst/writers, this effort is in constant jeopardy of inconsistency and error.
2. Editorial Review of Action Trees. This is an extremely time-consuming job. Since the checking is done by different people, a certain number of wrong references, inconsistencies, improper punctuation, poor grammar, etc. inevitably slip by.
3. Review Action Trees for Completeness. This requires considerable time, and involves hand-tallies and voluminous cross-checking between intermediate products and the Action Trees. A 100-percent complete review performed by humans is extremely difficult, and affords numerous opportunities for error.
4. Typing and Proofreading. This requires a great deal of clerical time, and is another good opportunity for errors to occur.

The Computer-Assisted Performance Aid Development and Production (CAPADAP) system combines all four of these functions (and a few others) into a single, comprehensive set of computer programs. The following two sections provide (1) a short discussion of traditional JPA development and production, and (2) a synopsis of how the CAPADAP system streamlines and vastly tightens quality control over the process. (Note: Although this material discusses only the Fully Proceduralized Troubleshooting Aid JPAs, the same CAPADAP techniques apply to Job Guide Manuals.)

The Traditional JPA Development/Production  
Process and Some Problems

Writing and Editing. Traditional JPA development begins with a detailed task analysis and proceeds through several steps to the development of Action Tree diagrams. Action Tree diagrams depict the sequence of steps to take in finding a malfunctioning part. The analyst/writer must determine what tests (voltage, resistance, etc.) the technician needs to make, and then write a clear instruction for the technician.

The outcome of every test either tells the technician to replace a part, or to go on to another numbered step. The other numbered step may be many pages away. The JPA analyst/writer must leave a blank space for the step number, and when all steps are eventually assigned numbers (days or weeks later), the analyst/writer must return and fill in the number. And, if a step number is changed somewhere in the middle of the step sequence, each subsequent step in the sequence must have its number changed too. The analyst/writer must catch every step whose number changes or the procedure will fail when tried.

Once the Action Tree diagrams are completed, they must be reviewed for editorial integrity. All statements must be very clear, simple, and unambiguous. All figure references and cross-referencing must be accurate. For large JPAs, this is an awesome task, all done by hand.

Clearly, the analyst/writer has many things that he must remember to do, including keeping the wording of his statements consistent and all his words spelled right. And, if it happens that JPA development is concurrent with hardware development, the analyst/writer must contend with interminable design alterations.

So, in developing Action Tree diagrams, the analyst/writer could make good use of a file of "standard statements" that would keep his wording, spelling, and punctuation consistent. If each "standard statement" had a reference number, he could use the number instead of having to write the same statement over and over. The analyst/writer could also use a system that would automatically number his troubleshooting steps, and renumber them each time a change occurred. The CAPADAP system does exactly these things.

Illustrations. Often, the same illustration can be used in several frames. This is quite cost-effective. But, if a change is made to an illustration that appears in 14 different places, the analyst/writer must dig through all of his material to locate every place the illustration is used. There is a reasonable probability that he might overlook a place. The analyst/writer could certainly use a system that would instantly tell him all the places where the illustration appears. This is one of the computer routines in CAPADAP.

Review for Completeness. Next, the analyst/writer must conduct a Review for Completeness. To do this, he prepares a list of all maintenance-significant components, and notes the number of failure modes (e.g., shorted, open, changed value) for each. Then he checks this list of

component-failure modes against his Action Tree diagrams to make sure the Action Trees include all the possible failure modes. This process runs into man-weeks even if only a few hundred frames must be reviewed. It must be done very painstakingly, because the validity of the JPAs depends on complete coverage.

The Review for Completeness is a massive undertaking, involving hundreds of loose papers (the draft action trees and intermediate products), and material literally "sitting around in boxes." Security is tenuous, and documents are subjected to all manner of minor environmental hazards. Misplacement of material is possible. The reviewers have to read various individual's handwritings, some less legible than others. And, the reviewers must often work from photocopies which occasionally obscure crucial letters and numbers.

It is excruciatingly difficult to conduct a perfect Review for Completeness, using people. What is needed is a system that automatically conducts a perfect review and catches all omissions, does so without reviewing reams of documents, and achieves this quickly. And that is what CAPADAP does.

Typing the Draft. Once the Review for Completeness is done, the Action Tree diagrams are revised as needed. Then, a draft is typed from the Action Tree diagrams. The draft must be proofread. The typing and proofreading take much time and present a fine opportunity for errors to invade the text. The draft must be photocopied so everyone concerned has a copy to work with. This takes more time. CAPADAP can type error-free, already-proofed multiple copies of a 1000-step draft in 10 minutes.

Typing the Draft Again. The next step is validation, during which time 100 percent of the Action Tree diagrams are tried out on actual gear, to make sure they work. Values (voltages, resistances, etc.) are also inserted at this time. The validated draft must be typed and proofread again, with the same problems as in the first typing. CAPADAP is needed again.

#### Understanding the CAPADAP System

The easiest way to understand CAPADAP System operation is to take an actual JPA text page and observe its step-by-step development. The sample text page we will use is shown in Figure A-9.

Standard Statements (SS). Examine Figure A-9 and you will notice that the same basic statements seem to recur. For example, Steps 922 and 923 read:

Using Simpson 260, connect + test lead to Q8 (10).  
Connect COMMON test lead to ground.  
Check that multimeter indicates between -14.8 and -15.2  
VDC. If not, go to Step 950.

JPA-PRELIMINARY-1

TROUBLESHOOT THE DEFLECTION  
AMPLIFIER

922. Using Simpson 260, connect + test lead to Q8 (10). Connect COMMON test lead to ground.
923. Check that multimeter indicates between -14.8 and -15.2 VDC. If not, go to step 950.
924. Using Simpson 260, connect + test lead to Q8 (9). Connect COMMON test lead to ground.
925. Check that multimeter indicates between -6.8 and -7.2 VDC. If not, go to step 958.
926. Set POWER switch (3) to OFF.
927. Set 28 VDC breaker (1) and 115 VAC 400 Hz breaker (2) to OFF.
928. Using Simpson 260, connect + test lead to Q8 (6). Connect COMMON test lead to ground.
929. Check that multimeter indicates 1890 ohms or more. If not, replace P.C. board 6A3A1 (5); go to step 1.
930. Replace 6A3A1Q8 (4), go to step 1.
931. Using Simpson 260, connect + test lead to Q7 (8). Connect COMMON test lead to ground.
932. Check that multimeter indicates between 14.8 and 15.2 VDC. If not, go to step 968.
933. Using Simpson 260, connect + test lead to Q7 (7). Connect COMMON test lead to ground.
934. Check that multimeter indicates between 6.8 and 7.2 VDC. If not, go to step 976.
935. Set POWER switch (3) to OFF.
936. Set 28 VDC breaker (1) and 115 VAC 400 Hz breaker (2) to OFF.

1-218

Figure A-9. A Sample JPA Text Page

Steps 924 and 925 use the same basic statement:

Using Simpson 260, connect + test lead to Q8 (9).  
 Connect COMMON test lead to ground.  
 Check that multimeter indicates between -6.8 and -7.2  
 VDC. If not, go to Step 958.

The only differences between the two statements are the "connect + test lead to" point and callout, the voltages, and the next step to go to.

If blanks are substituted for these elements, we have:

Using Simpson 260, connect + test lead to \_\_\_\_\_ ( ).  
 Connect COMMON test lead to ground.  
 Check that multimeter indicates between \_\_\_\_\_ and  
 \_\_\_\_\_. If not, go to \_\_\_\_\_.

This is a statement which can be used many times in many places, by simply inserting the four missing elements. It is called a "standard statement."

In JPA writing, many such "standard statements" are used. In fact, the majority of statements used in JPAs (more than 80 percent in some-books) are repetitive "standard statements." A close study of Figure A-9 reveals that only four standard statements are required for the entire page. These four standard statements are shown in Figure A-10.

When CAPADAP is to be used in a JPA production project, the first step is to prepare a list of appropriate Standard Statements (SS). Each SS is assigned a Code Number for reference.

The computer now has in storage a file of letter-perfect SS that will be used time and again throughout the JPAs. These SS require no further attention. A large portion of the JPA editing is now complete.

Now the JPA analyst/writers can begin preparing the Action Tree diagrams. A sample is shown in Figure A-11. The analyst/writer analyzes the circuit, and sees that the technician's first step must be to measure the VDC between Q8 and the ground, using the Simpson 260 multimeter. The analyst/writer flips through his printout of the computer's SS File, and finds what he needs: SS #9 (see Figure A-10). Instead of having to write out the full statement, he simply writes "SS #9" on the Action Tree diagram. Then, he notes the data needed to fill in the blanks of SS #9: Q8 (what the + test lead connects to), and AT12-6 (the next point in Action Tree #12 to which the technician must proceed). Note: The callout number in parentheses is added during formatting; the VDC values are added during validation.

The analyst/writer then moves to the next check the technician must make, looks up the appropriate SS, notes the SS# in the next block of the Action Tree diagram, and records the data needed to fill the blanks in this SS.

<u>CODE NO.</u>	<u>STANDARD STATEMENT</u>
9.	Using Simpson 260, connect + test lead to ____ ( ). Connect COMMON test lead to ground.  Check that multimeter indicates between _____ and _____. If not, go to _____.
11.	Using Simpson 260, connect + test lead to ____ ( ). Connect COMMON test lead to ground.  Check that multimeter indicates _____ or more. If not, replace _____ ( ); go to _____.
43.	Replace _____ ( ). Go to _____.
54.	Set POWER switch ( ) to OFF.  Set 28 VDC breaker ( ) and 115 VAC 400 Hz breaker ( ) to OFF.

Figure A-10. Standard Statements for the  
Sample JPA Text Page

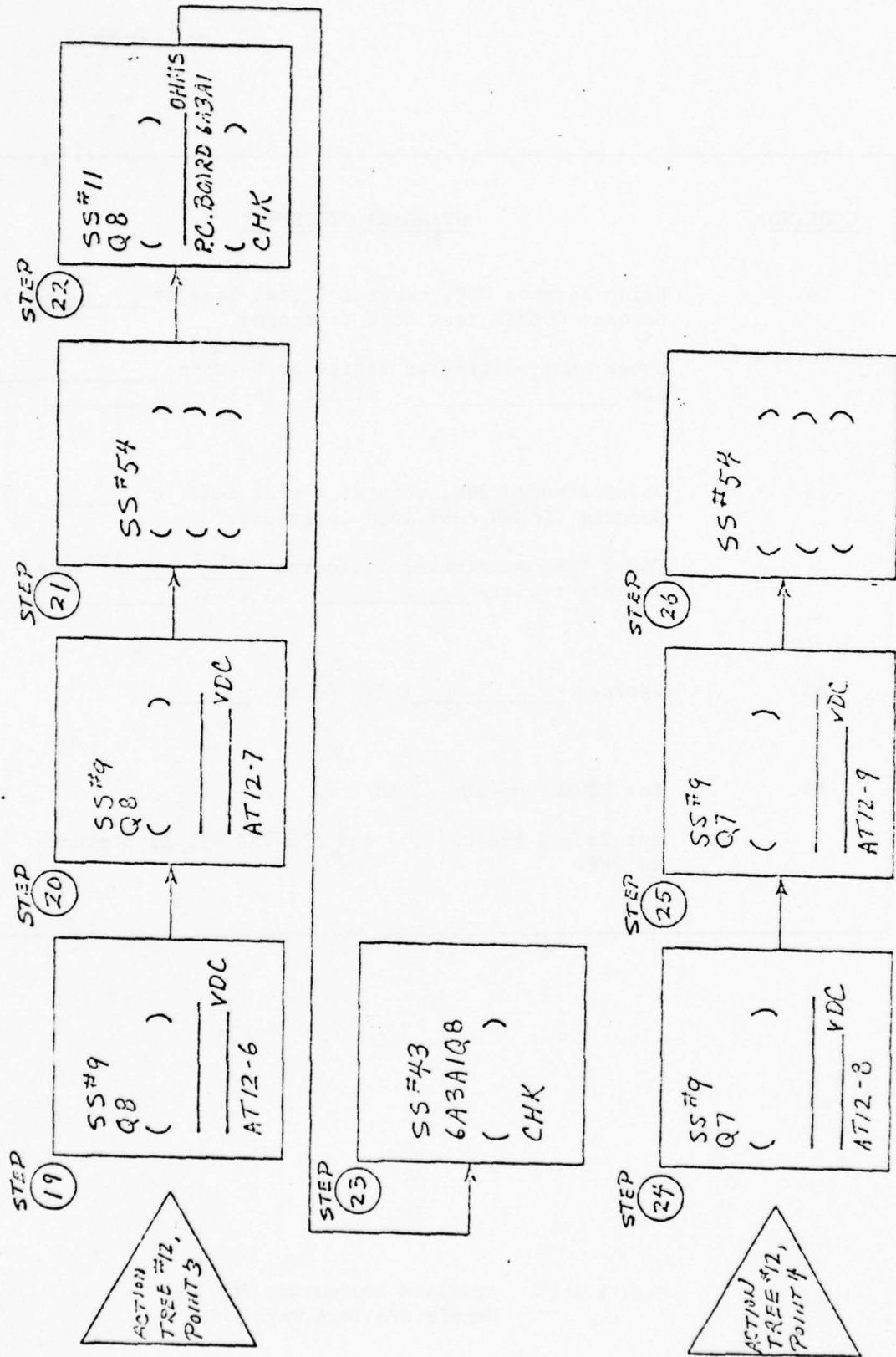

Figure A-11. Sample Action Tree Diagram for the Sample JPA Text Page

"Writing" the Action Tree diagrams in this way is simple. Advantages:

1. It is fast (SS numbers are written instead of whole sentences).
2. It makes changes of SS easy (only the SS number is corrected, instead of erasing and rewriting whole sentences).
3. It prevents inconsistent versions of steps from different analyst/writers (no matter which writer prepares an Action Tree diagram, the SS will always be identical).
4. A much higher percentage of the analyst/writer's time is spent on technical matters, while lowering the total "technical writing" time per frame.

The analyst/writer's Action Tree diagrams now go to the Computer Terminal Operator (CTO). The CTO prepares a computer file that contains all the values needed to fill in all the blanks in all the SS. This file is the "Logic/Value File."

Non-Standard Statements (NS). What happens if the JPA analyst/writer scans his list for an appropriate SS and can't find one? This occurs occasionally because a particular test may be made only once in the entire system. In this case, the analyst/writer must generate a unique "Non-Standard Statement" (NS).

The analyst/writer composes the statement and writes it beneath the block on the Action Tree diagram. He assigns a NS Code Number to it (24 in this case). In the block, he notes the same type of data that he normally writes in SS blocks. When this Action Tree diagram reaches the CTO, the CTO will see the Non-standard Statement. The CTO then generates another computer file, the "NS File." The NS and its Code Number are typed into the computer and the data required to fill the blanks in the NS are entered into the computer's Logic/Value File. Once all Non-standard Statements for the whole system are in the NS File, a printout of the file is run, edited, and corrections are typed into the computer. Now all NS used in the JPAs are letter-perfect and need not be reviewed again.

CAPADAP's Instant Quality Checks. At this point, the entire JPA "draft" is complete (except for values and callouts), edited, and stored in three files in the computer (the SS File, NS File, and Logic/Value File). Before a printout of the draft is run, however, two internal computer reviews are run:

1. Logic/Value File Review
2. Review for Completeness.

These reviews are outstanding features of CAPADAP and are the functions that so dramatically enhance development/production quality control. The following paragraphs explain what the reviews achieve.

Logic/Value File Review. This review checks the Logic/Value File to see if its contents makes sense. The computer searches through the Logic/Value File, and checks for a variety of errors. The Review examines 24 different dimensions, the most essential of which are:

1. "Go to \_\_\_\_\_" instructions. Does the Logic/Value File contain a "go to" point for all of these instructions? Were any left blank? Do all the "go to" points in the file actually exist? Has the writer inadvertently assigned the same designation to two different "go to" points?
2. The Action Tree diagram blocks. Are any of the steps within an Action Tree diagram out of sequence?
3. In each Logic/Value File entry, an SS or NS is referenced. Are the referenced statements actually in the SS and NS Files?
4. If an SS has, say, three blanks, are there three data items in the Logic/Value File for those blanks? Were any omitted, or are there too many? (All SS and NS are checked.)
5. Are the values in the Logic/Value File the right type for their assigned blanks in each SS and NS?

If the Logic/Value File Review discovers any discrepancies, the computer prints out a list of them, stating what's wrong and exactly where. It is a simple matter to take this discrepancy list, run down the problems with the analyst/writer or CTO, and type corrections into the computer. Once this is done, the Logic/Value File has no "holes."

Review for Completeness. The Logic/Value File Review established that there are no discrepancies among the computer contents. But are we sure that everything is in the computer that should be? The Review for Completeness is the second "instant quality check." It makes sure all components have the right number of statements for the number of ways the component can fail. See Figure A-12, Example Failure Modes.

To perform this review, a list of function failures is prepared and entered into the computer. The computer scans its Logic/Value File, looking only at steps where components are replaced. It tallies the number of times each component is replaced. It also notes any components it finds being replaced that aren't in the function failure list. The computer then prints out another discrepancy list which itemizes all discrepancies and states where they occur. The analyst/writer takes the list, runs down the problems, and has corrections typed into the computer.

Like the Logic/Value File Review, this Review for Completeness has accomplished in minutes what used to take weeks. But most importantly,

Possible Failure Modes for Typical Electronic Equipment

Component Type	Number of Modes	Type of Failure Modes
Capacitor	2 or 3	Open, short, value change when critical
Crystal Filter	2	Improper operation and insulation breakdown
Crystals, Oscillating	2	Improper operation and insulation breakdown
Diode	2	Open (high forward resistance), shorted (low reverse resistance)
Fuse	1	Open
Inductor	2	Insulation breakdown, value change
Lamp	Equal to the number of filaments	Filaments open
Meter	3	Out of calibration, mechanical sticking, insulation breakdown
Motor	Three times the number of separate windings plus 2	Each winding could: open, short or contain an insulation breakdown. Plus each motor may have internal or external mechanical load problems.
Plug or Jack	Equal to twice the number of active connections	Open or insulation breakdown

Figure A-12. Example Failure Modes

the Review for Completeness has caught every discrepancy and established the final quality of the JPAs.

Illustration Review. Another important check is also made: the Illustration Usage Analysis. The computer is commanded to print out a list of all illustrations used in the JPAs, indicating how many times each is used, and where it is referenced in the text. This information will be used where validation indicates that an illustration should be changed, to assure that all occurrences of the illustration are changed. Also, this list gives the JPA production manager a precise tally of how many times each illustration is required. The computer also detects illustrations that are never used, and flags these.

Validation. The JPA steps are now tried out on actual equipment. There will be inevitable changes, adding and deleting steps and series of steps. Deleted steps are simply erased from the SS, NS, and Logic/Value Files. Added steps are handled like the original Action Tree diagrams: find the applicable SS in the list (or create an NS, if needed), record the statement's Code Number and the values for its blanks, and have the CTO type it into the computer. If alterations disturb the draft step-number sequence, the computer will automatically renumber the steps.

Also during validation, the missing values (voltage, resistances, etc.) and associated tolerances are determined and plugged into the draft. The CTO types these values into the computer, which adds them to its Logic/Value File.

One of the major values of the computer system is that validation is entered with a draft more nearly complete and correct than has been possible heretofore. This results in a dramatic reduction in interruptions to make corrections, and thus in much more efficient use of equipment access time. And, there is a concomitant reduction in the calendar time which would otherwise be required for validation.

Formatting. If the first draft has not been seriously altered by validation, it can be used for formatting. If it has been extensively changed, a fresh draft incorporating the validation changes can be obtained as quickly as the initial draft.

Analyst/writers now go over the draft, coordinating the illustrations with appropriate JPA steps. They mark the draft to indicate page breaks, and insert callout numbers in the text parentheses. The CTO types the page breaks and callout numbers into the computer Logic/Value File. This completes the contents of this file.

Verification and the Final Copy. The JPA draft can now be verified with a user tryout. Corrections, if any, are made in the same way as those resulting from validation. Finally, when everyone is satisfied with the JPA draft, the computer is given a command to print out camera-ready final copy over a low-speed, high quality printer located in ASA's Computer Terminal Room. If any transmission difficulties occur, the printer has error-detectors which alert the CTO to the problem.



probabilities that the malfunctioning LRI lies on one side or the other of the check. This strategy defines the half-split technique of troubleshooting. The half-split technique should be modified by introducing the following considerations:

Accessibility - Checks that are easy to make should be made early in the tree. Checks that involve extensive or difficult disassembly should be written toward the end of the tree. The accessibility consideration adds a practical dimension to half-splitting, since time required to perform the check is also a measure of action tree efficiency.

Accidental Malfunction Introduction - Those checks which have a high probability of introducing accidental equipment damage should be sacrificed for less efficient checks whenever possible. If there are no other equivalent checks, a damage-likely check should be deferred toward the end of the tree.

Refer to the Test Equipment and Tool Use Form each time a procedural step calls for the use of a special tool or piece of test equipment. Be certain that the procedural steps contain all control settings or other operating instructions required by the form each time a special tool or piece of test equipment is used.

3. When developing strategies for within-stage troubleshooting of solid state devices or other direct coupled stages, the following considerations apply:
  - a. Using half-split technique, check output of all suspect stages. Bad stages are denoted by a good indication immediately followed by a bad indication.
  - b. When a stage is suspect, isolate it by disconnecting the load. Recheck the previously bad indication. If indication is now good, begin troubleshooting the following stage. If indication is still bad, troubleshoot the suspected stage.
  - c. When we find that after isolating a suspect stage from its load, it is the load (following circuit, input) that is defective, we should use the following strategy: First, test the input terminals of the defective stage's active component. If input tests are bad, remove active device and check input circuit passive components. If a passive component as well as the active one has failed, replace them both and direct the user to repeat the previous stage output test. If the output test is now passed, the user should be directed to return to the checkout and proceed. However, if the stage output test is failed a second time after the repair should have been effected, the user should be directed to obtain assistance.

This approach is somewhat different than ones used in the past and the emphasis is on shortening maintenance technician feedback time in difficult repair situations. Rather than being sent from the repair directly back to the check to start over, the change has the technician repeat the previously failed (stage specific) check. If this check is now satisfactory, the technician is permitted to return to the checkout and proceed. If not, either the technician committed a procedural error or he further damaged the equipment while effecting the repair. In either case, it's a matter for his supervisor to decide.

The same final sequence (beginning with repeat the stage output test) should be performed if only a passive component has failed, or if only an active component has failed.

- d. The final sequence just described for troubleshooting is appropriate for any direct-coupled circuit. The previous case only considered the input circuit, since it was loading the output of the preceding stage. When the defect is located within the stage that originally appeared defective, it is first necessary to, in circuit, check the junctions of the active component. For a transistor, this means five checks: base to emitter, forward and reverse; base to collector, forward and reverse; collector to emitter, reverse. In each of the junction checks, if a fault is found, the associated external (passive) circuit must also be checked. The possibilities in this case include a passive component as well as the active one.

If the active circuit checks out properly, the peripheral passive components will remain suspect and must be checked out conventionally.

Two procedures taken from the JPA manuals used in the AQA-7 program follow:

Checkout and Troubleshoot of a Voltage Regulator Assembly.

Replacement of a CRT Assembly.

## SECTION IV

13PS3 REGULATOR ASSEMBLY VOLTAGE FORM 35V, FORM 15V, -10V, CHECKOUT AND TROUBLESHOOT4-1. PRELIMINARY CONDITIONS.

4-2. This procedure covers the Check-out and Troubleshooting of the 13PS3 Regulator Assembly Voltage FORM 35V, FORM 15V, and -10V.

4-3. APPLICABLE PART AND SERIAL NUMBERS.

4-4. This procedure is effective for Part No. 535105-801.

4-5. SPECIAL TOOLS AND TEST EQUIPMENT.

4-6. The special tools and test equipment required for performance of this procedure are:

- Simpson 260 Multimeter
- Tektronix 454 Oscilloscope
- Fluke 8300A Digital Voltmeter
- AN/AQM-20

4-7. SUPPLIES.

4-8. The materials required for performance of this procedure are Maintenance Action OPNAV Forms 4790/40 and 4790/41.

4-9. PERSONNEL REQUIREMENTS.

4-10. One AQA-7 Job-Oriented Training Graduate is required to perform this task.

4-11. EQUIPMENT CONDITIONS.

4-12. Prerequisite to the performance of this procedure are the following equipment conditions:

- The 60 Hz and 400 Hz circuit breakers located on the CONSOLE POWER PANEL are set to ON.

-The 60 Hz and 400 Hz switches located on the CONSOLE POWER PANEL are set to ON.

-The 60 Hz and 400 Hz POWER switches located on the SIGNAL PANEL are set to OFF.

-The DC and 400 Hz POWER switches located on the TEST POWER CONTROL are set to OFF.

-The U/OV VOLTAGE TEST switch is set to 1.

-The 1A7PS1, 1A7PS2, 1A8PS1, and 1A8PS2 circuit breakers are set to ON.

-I Limit on 1A7PS1, 1A8PS1, and 1A8PS2 has been rotated to clockwise extreme.

-All rotary switches on the load control drawer have been set in extreme counterclockwise position.

-The 400 Hz POWER switch located on the TEST POWER CONTROL is set to ON.

-The 3 phase AC ADJUST located on TEST POWER CONTROL has been adjusted for 115 VAC.

-The 400 Hz POWER switch located on TEST POWER CONTROL is set to OFF.

-The DVM SELECT switch is set to OFF.

4-13. NOTES, CAUTIONS, AND WARNINGS.

4-14. No general NOTE, CAUTION, or WARNING applies to this procedure.

4-15. ACTIVITY INDEX.

4-16. Activities covered in this manual are listed in the AN/AQA-7 Manual Index which appears at the beginning of this manual.

13PS3 REGULATOR ASSEMBLY VOLTAGE FORM -35V, PORM 15V, -10V,  
CHECKOUT AND TROUBLESHOOT

57. Check that displayed waveform is similar to (1). If not, replace 13PS3C3 (3); go to step 1.

58. Set PWR SUPPLY LOAD switch (5) to 1.

59. Set and hold LOAD switch (4) to LOW.

60. Check that DVM indicates between -8.7 and -9.7 VDC. If not, go to step 251.

61. Set and hold LOAD switch (4) to HIGH.

62. Check that DVM indicates between -8.7 and -9.7 VDC. If not, go to step 251.

63. Release LOAD switch.

64. Set PWR SUPPLY LOAD switch (5) to 2.

65. Set and hold LOAD switch (4) to LOW.

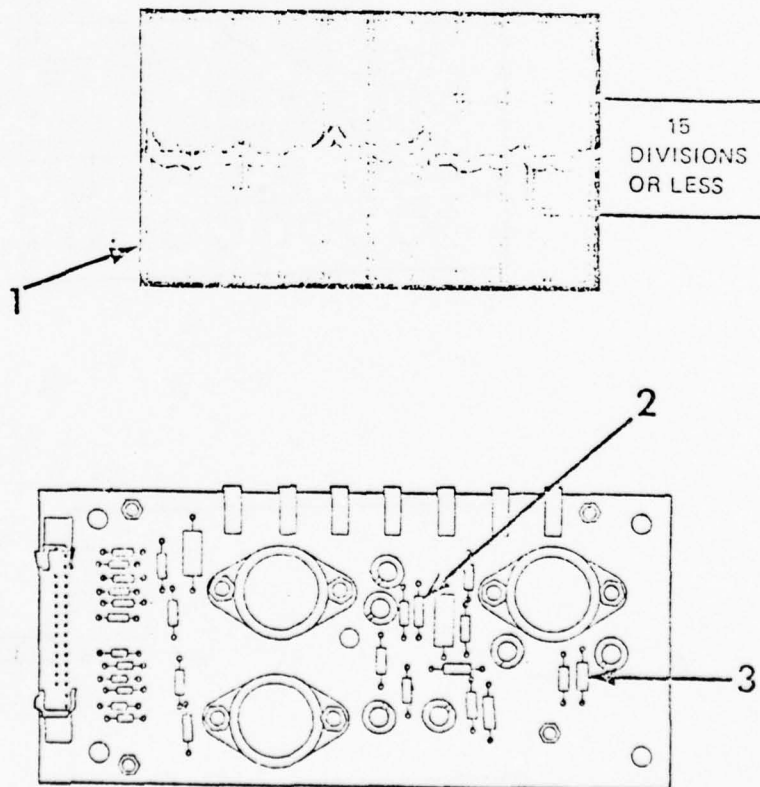

13PS3 REGULATOR ASSEMBLY VOLTAGE FORM -35V, PORM 15V, -10V,  
CHECKOUT AND TROUBLESHOOT

66. Check that DVM indicates between +14.3 and +15.7 VDC. If not, go to step 318.

67. Set and hold LOAD switch (4) to HIGH.

68. Check that DVM indicates between +14 and +16 VDC. If not, go to step 318.

69. Release LOAD switch.

70. Set VOLT/DIV switch to 20 mV.

Set TIME/DIV switch to 2 ms.  
Set TRIGGERING SOURCE to INT.  
Set COUPLING switch to AC.

71. Check that displayed waveform is similar to (6). If not, replace 13PS3C4 (2); go to step 1.

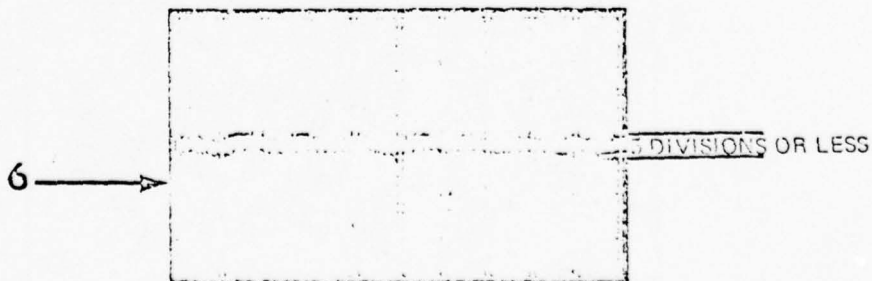
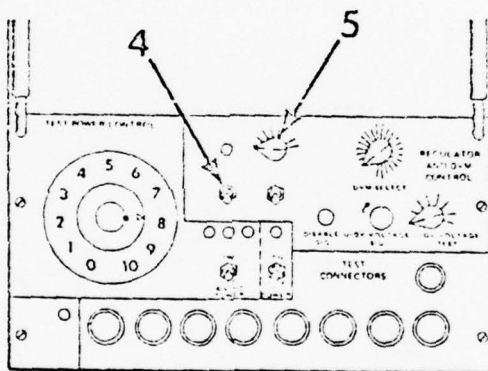

## SECTION VI

6A2 ELECTRON TUBE ASSEMBLY, REPLACE6-1. PRELIMINARY CONDITIONS.

6-2. This procedure covers the replacement of the 6A2 Electron Tube Assembly.

6-3. APPLICABLE PART AND SERIAL NUMBERS.

6-4. This procedure is effective for IP981, PN 709570-801.

6-5. SPECIAL TOOLS AND TEST EQUIPMENT.

6-6. The special tools and test equipment required for performance of this procedure are:

- Pin Extractor Tool TS-39025
- Pin Insertion Tool TS-38025
- 10" No. 2 Phillips Screw Driver

6-7. SUPPLIES.

6-8. The materials required for performance of this procedure are Maintenance Action OPNAV Forms 4790/40 and 4790/41, wire marking tags, and a storage container for used CRT.

6-9. PERSONNEL REQUIREMENTS.

6-10. One AQA-7 Job-Oriented Training Graduate is required to perform this task.

6-11. EQUIPMENT CONDITIONS.

6-12. Prerequisite to the performance of this procedure are the following equipment conditions:

- The AN/AQM-18 28 VDC and 115 VAC switches are set to OFF.
- The BFI to be serviced is disconnected from the TBH and placed on a convenient work surface.

6-13. NOTES, CAUTIONS, AND WARNINGS.

6-14. The following NOTE and WARNING apply to this procedure:

NOTE

When finished replacing CRT, check with your supervisor about proper handling and disposal of the used CRT.

WARNING

To prevent possible serious injury, avoid striking or damaging exposed glass portions of CRT during removal and installation.

6-15. ACTIVITY INDEX.

6-16. Activities covered in this manual are listed in the AN/AQA-7 Manual Index which appears at the beginning of this manual.

## 6A2 ELECTRON TUBE ASSEMBLY, REPLACE

## Remove the Electronic Tube Assembly

1. Loosen four thumbscrews (2).
2. Remove 6A3 (1).
3. Loosen four screws (4).
4. Remove 6A4 (5) and 6A5 (3).
5. Remove twelve screws (12).
6. Remove bezel (13).
7. Rotate TRACE A THRESHOLD control (10) fully counterclockwise.
8. Loosen two setscrews (14) on TRACE A THRESHOLD knob (10). Remove knob (10).
9. Rotate TRACE C THRESHOLD control (9) fully counterclockwise.

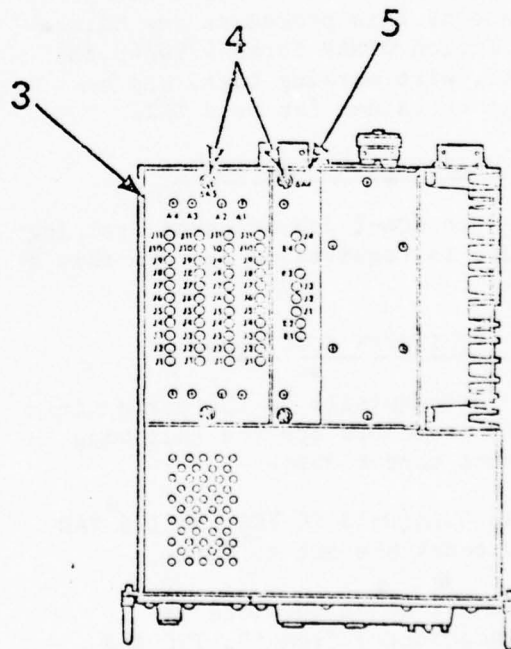
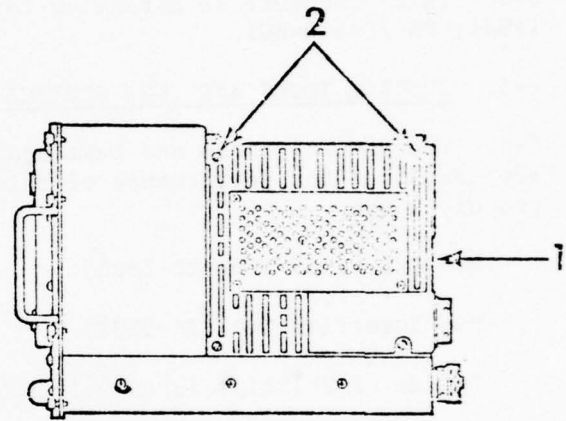
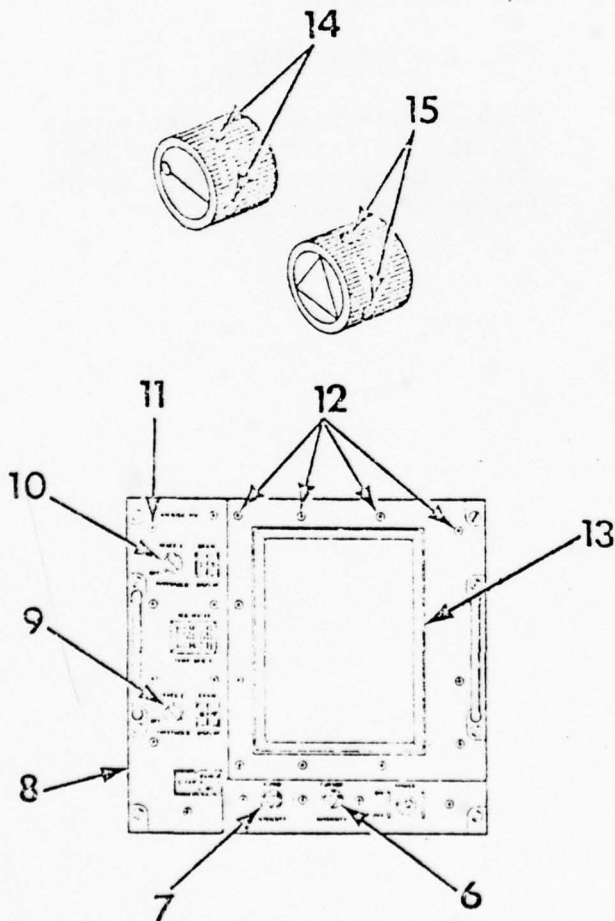

## 6A2 ELECTRON TUBE ASSEMBLY, REPLACE

Remove the Electronic Tube Assembly

10. Loosen two setscrews (14) on TRACE C THRESHOLD knob (9). Remove knob (9).

11. Rotate VIDEO INTENSITY control (7) fully counterclockwise.

12. Loosen two setscrews (15) on VIDEO INTENSITY knob (7). Remove knob (7).

13. Rotate CURSOR INTENSITY control (6) fully counterclockwise.

14. Loosen two setscrews (15) on CURSOR INTENSITY knob (6). Remove knob (6).

15. Remove twelve screws (11).

**CAUTION**

When removing edge panel, carefully pry panel forward to prevent damage to panel and hidden power plug.

16. Remove panel (8).

17. Remove fifteen screws (16).

**CAUTION**

When removing panel, pull panel straight out approximately four inches to prevent damaging switch terminals on rear of panel.

18. Remove panel (17).

**CAUTION**

Use caution when moving chassis to prevent damage to panel wiring and switch terminals.

19. Remove eight screws (19).

20. Remove cover (18).

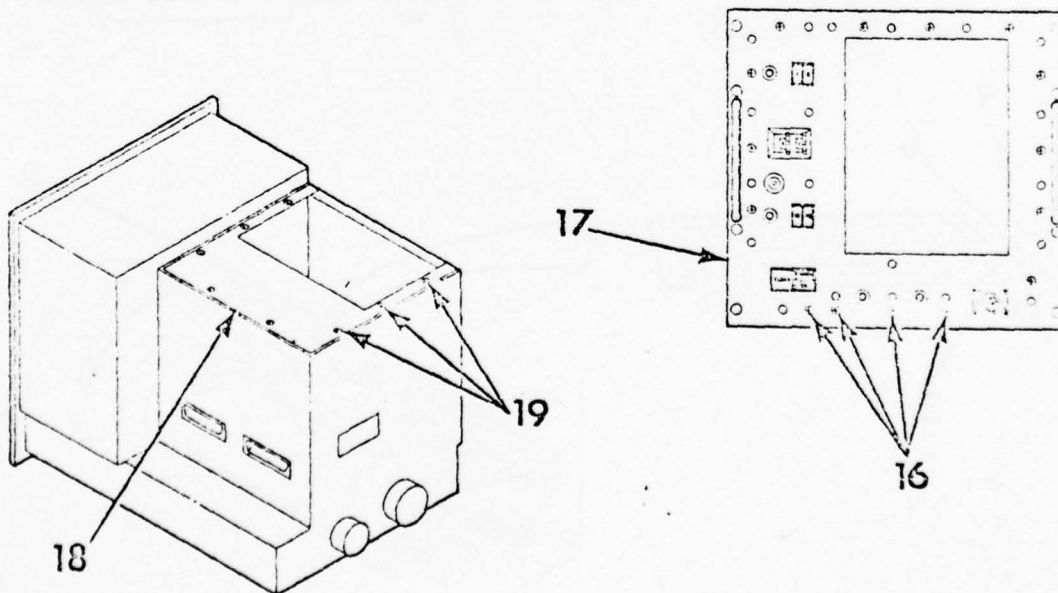

6A2 ELECTRON TUBE ASSEMBLY, REPLACE  
Remove the Electronic Tube Assembly

21. Disconnect 6A2P6 (1) from 6J5.

22. Using pin extractor tool TS39025, remove and tag lead (3) from XA3P1 (2).

23. Using pin extractor tool TS39025, remove and tag lead (6) from XA3P1 (2).

24. Using pin extractor tool TS39025, remove and tag lead (5) from XA3P1 (2).

25. Using pin extractor tool TS39025, remove and tag lead (4) from XA3P1 (2).

26. Remove screw (8).

27. Remove ten screws (9).

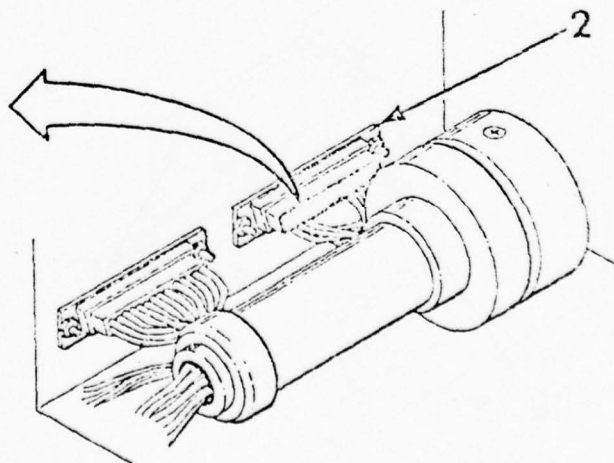
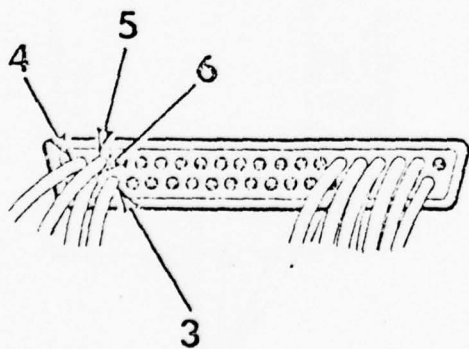
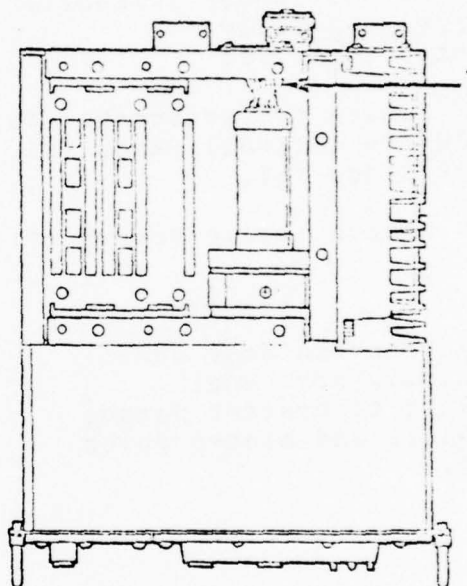
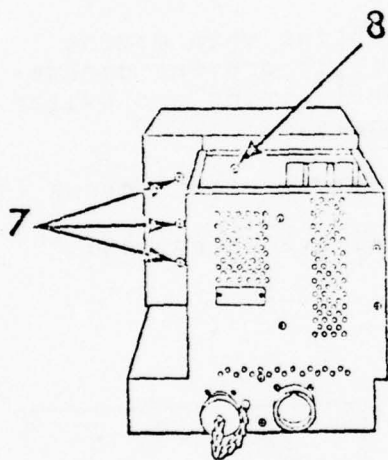

## 6A2 ELECTRON TUBE ASSEMBLY, REPLACE

Remove the Electronic Tube Assembly

28. Remove cover (10).

29. Disconnect 6A2P1 (11) from 6A6J1.

30. Remove screw (12).

31. Remove three screws (7).

32. Remove CRT assembly (13) through front of chassis.

33. Place CRT assembly in padded container to prevent damage.

34. REMOVE ENDS HERE

WARNING

To prevent possible serious injury, avoid striking or damaging exposed glass portions of CRT during removal and installation.

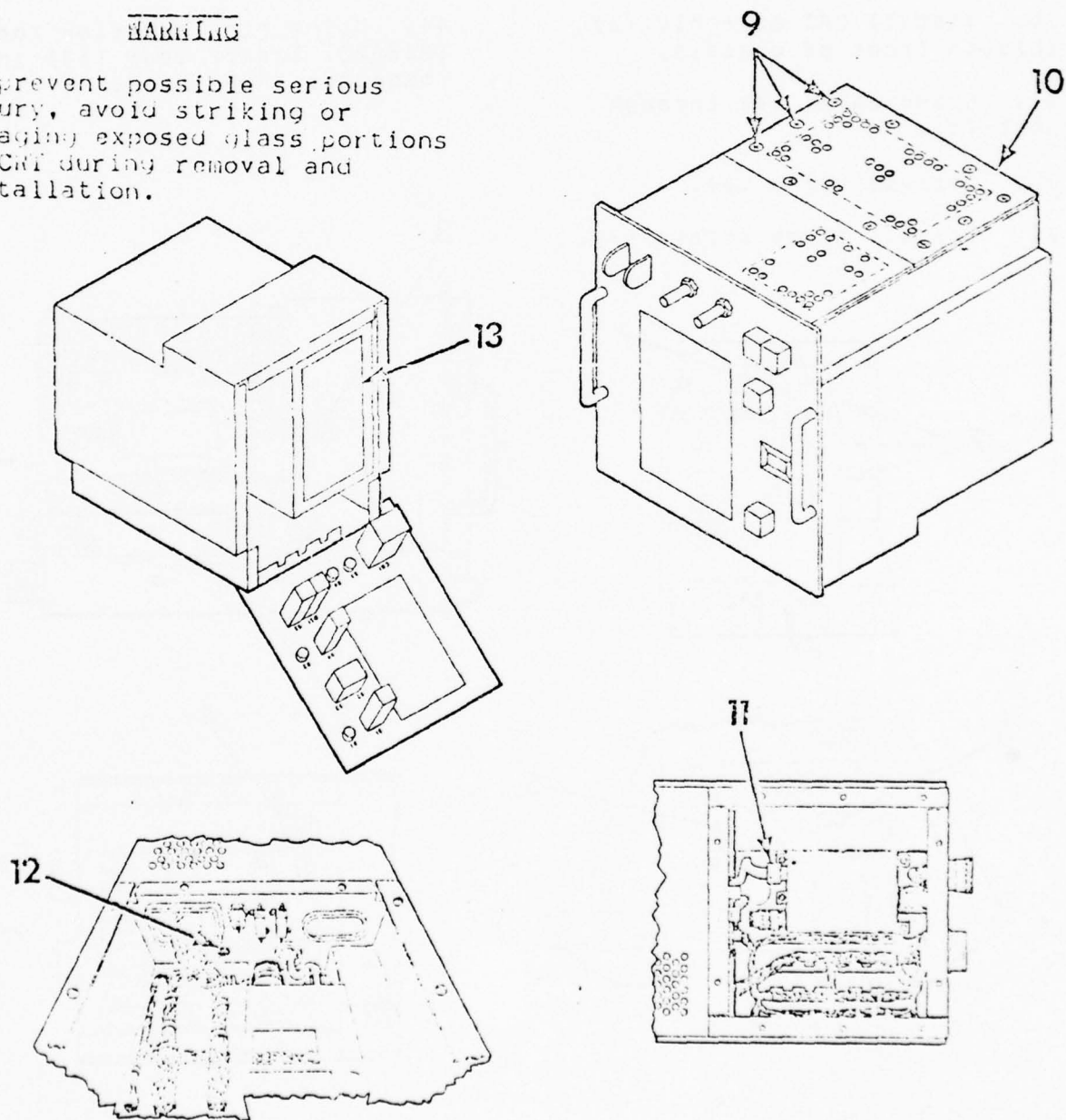

## 6A2 ELECTRON TUBE ASSEMBLY, REPLACE

## Install the Electronic Tube Assembly

WARNING

To prevent possible serious injury, avoid striking or damaging exposed glass portions of CRT during removal and installation.

35. Position CRT assembly (3) with 6A2P1 (2) facing down.
36. Install CRT assembly (3) through front of chassis.
37. Guide 6A2P1 (4) through port (5).
38. Install screw (6).
39. Install three screws (7).
40. Install screw (8).
41. Reconnect 6A2P1 (4) to 6A6J1.
42. Install cover (10) and secure with ten screws (9).
43. Reconnect 6A2P6 (1) to 6J5.
44. Using pin insertion tool TS38025, insert lead (13) into connector XA3P1 (11).

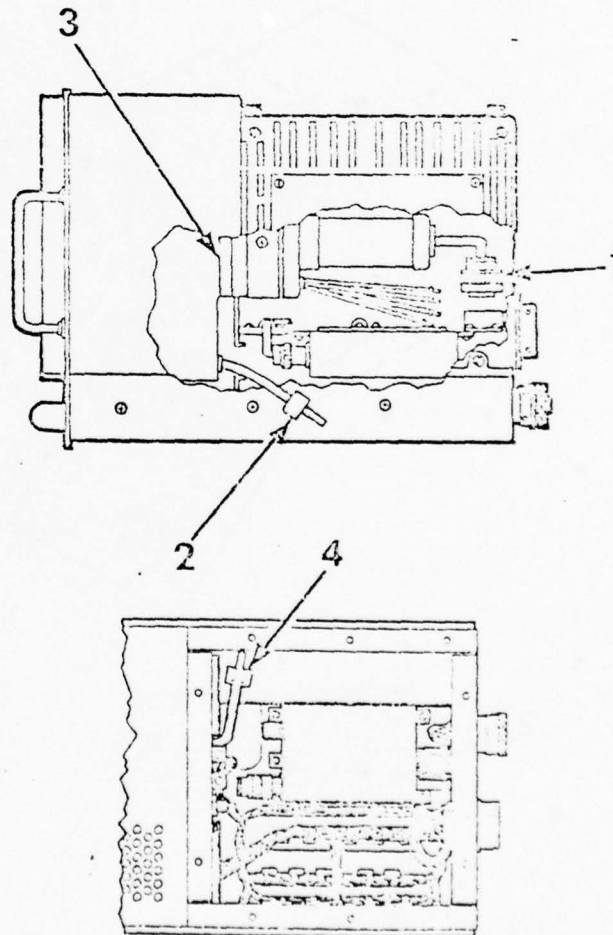
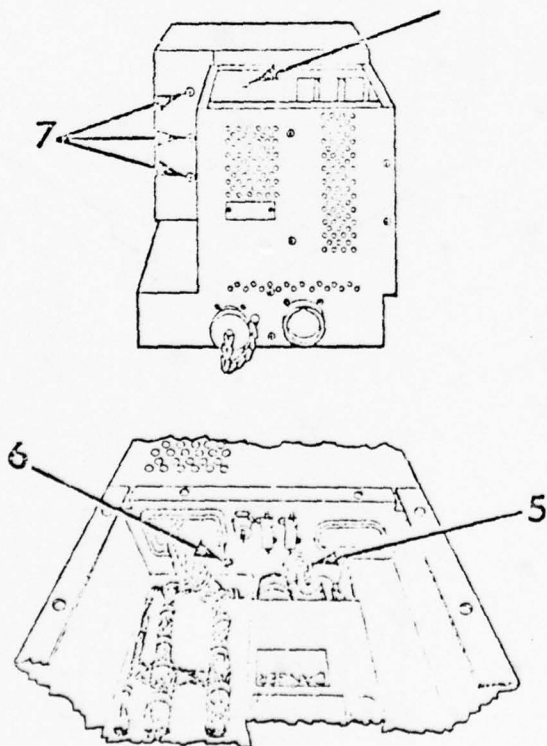

6A2 ELECTRON TUBE ASSEMBLY, REPLACE  
Install the Electronic Tube Assembly

45. Using pin insertion tool TS38025, insert lead (14) into connector XA3P1 (11).

46. Using pin insertion tool TS38025, insert lead (15) into connector XA3P1 (11).

47. Using pin insertion tool TS38025, insert lead (12) into connector XA3P1 (11).

48. Install cover (16) and secure with eight screws (17).

49. Check that panel wiring and connectors are not damaged. If damaged, repair or replace wiring and connectors as necessary.

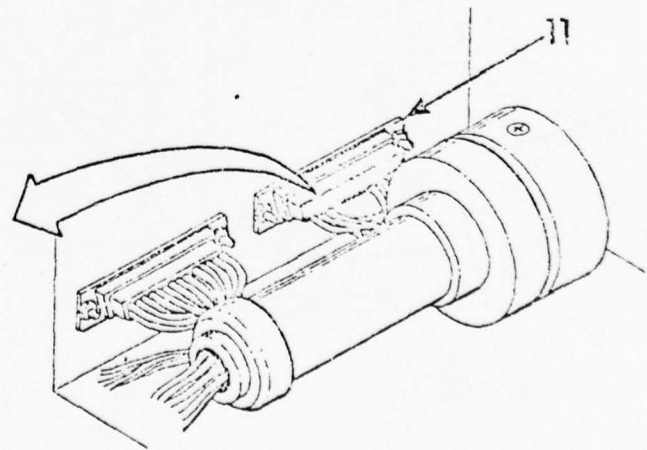
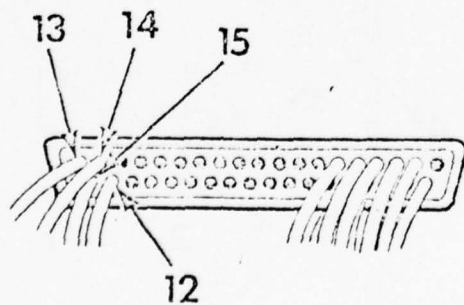
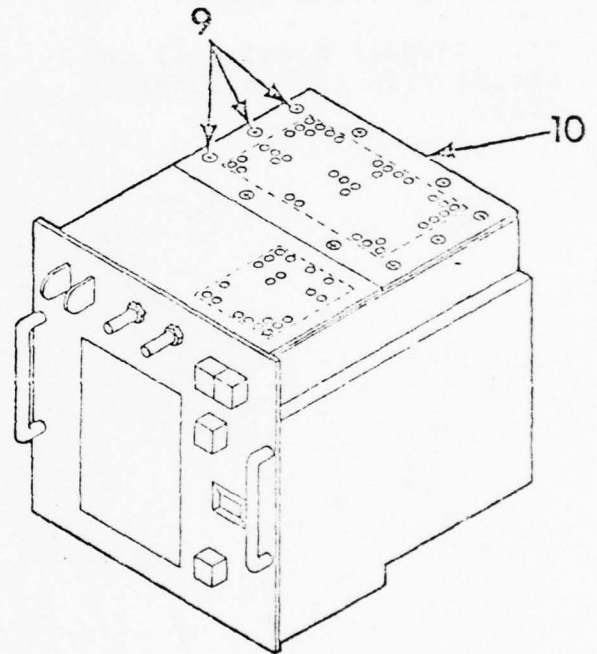
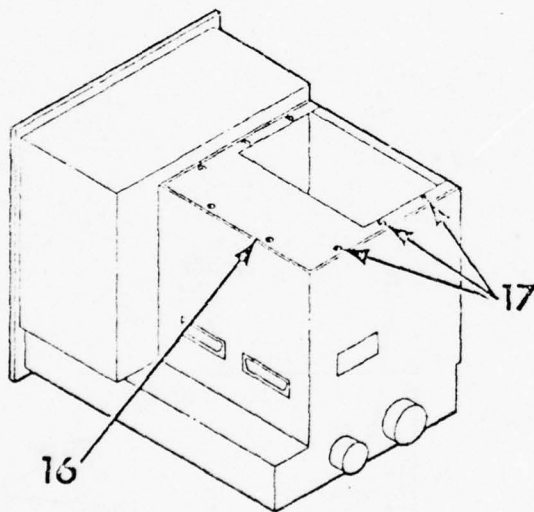

## 6A2 ELECTRON TUBE ASSEMBLY, REPLACE

## Install the Electronic Tube Assembly

50. Install panel (6) and secure with fifteen screws (1).

**CAUTION**

When installing edge panel, check that power plug is properly aligned before securing panel.

51. Install panel (11) and secure with twelve screws (12).

52. Install bezel (14) and secure with twelve screws (7).

53. Rotate TRACE A THRESHOLD control (5) fully counterclockwise.

54. Install TRACE A THRESHOLD knob (13) with position dot set to OFF. Secure with setscrews (15).

55. Rotate TRACE C THRESHOLD control (4) fully counterclockwise.

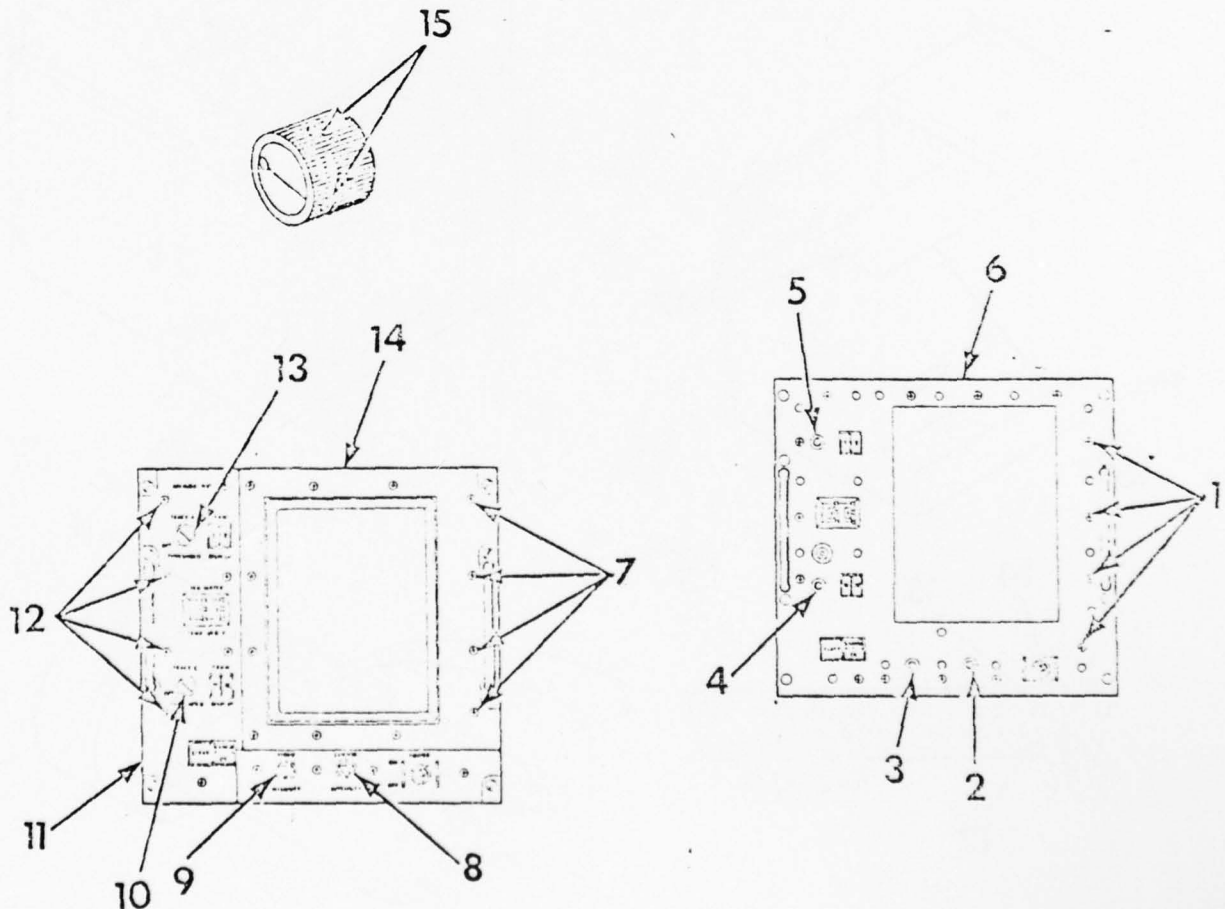

6A2 ELECTRON TUBE ASSEMBLY, REPLACE  
Install the Electronic Tube Assembly

56. Install TRACE C THRESHOLD knob (10) with position dot set to OFF. Secure with setscrews (15).

57. Rotate VIDEO INTENSITY control (3) fully counterclockwise.

58. Install VIDEO INTENSITY knob and secure with setscrews (9).

59. Rotate CURSOR INTENSITY control (2) fully counterclockwise.

60. Install CURSOR INTENSITY knob and secure with setscrews (8).

61. Install 6A3 (16) and secure with four screws (17).

62. Install 6A4 (20) and secure with screws (18).

63. Install 6A5 (19) and secure with screws (18).

64. END OF ACTIVITY

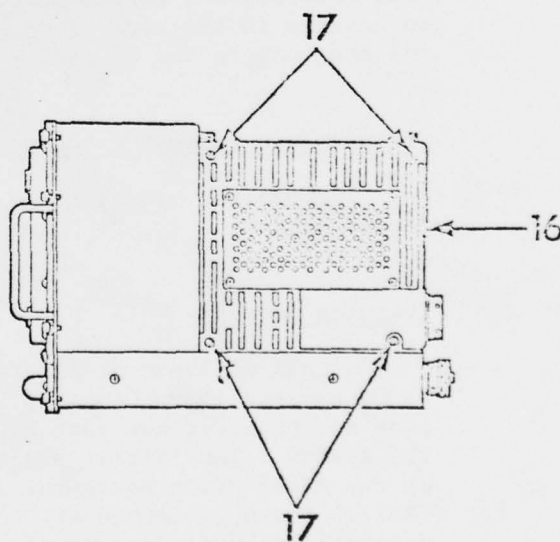
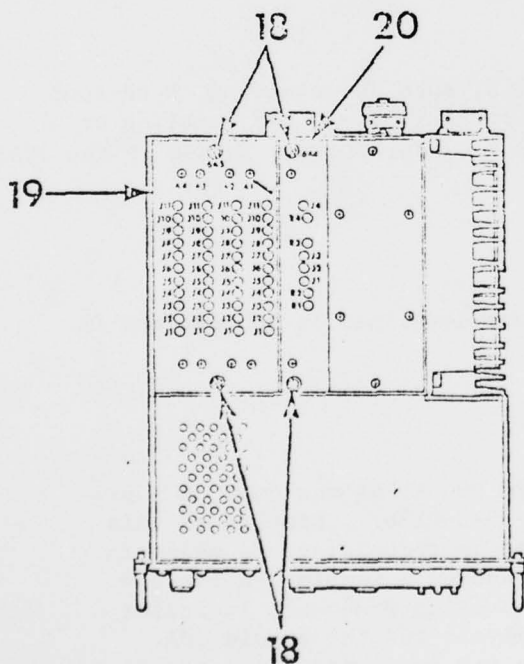

Training DevelopmentIntroduction

The training development effort had several objectives, some of which were unique to this program. The audience was to be Navy recruit training graduates with no prior training or experience in electronics. The intelligence and aptitudes of this audience were average. As such, they would not have been eligible for electronics training in the Navy except for this program. The objective was to teach only those skills and knowledges required to permit them to perform their tasks using specialized technical data--the JPA. Since that data obviated the need for them to perform some of the tasks which conventional technicians are sometimes called upon to perform, the training did not need to, and did not, treat a variety of subject matter areas frequently found in more conventional electronic training materials. Some examples are:

- . Atomic theory
- . Electronics math
- . Data flow analysis
- . Electron flow tracing
- . Signal parameter estimating
- . Unnecessary vocabulary

The training focused on manual skills, such as soldering, hand-tool use, assembly and disassembly; system geography, i.e., the location of components in the aircraft and on the test bench; fluency in use of the JPA; and accuracy in use of test equipment.

Training Development Process

The process by which the training was developed is schematized in Figure A-13.

Training Content

A task analysis of AQA-7 maintenance functions was done on a previous project (Navy Contract No. N62269-73-C-0176). Results of this task analysis defined what had to be done by technicians to maintain the system. The initial project also produced a sample JPA for one of the AQA-7 prime equipment units, the Bearing Frequency Indicator (BFI). These two products, the task analysis and the sample JPA, provided one major source of information for decisions about training program content. A review of the two documents quickly revealed, for example, that in order to use the JPA for maintaining the system, technicians would have to know how to use certain test equipment and hand tools. Thus, a decision was made to include a section in the

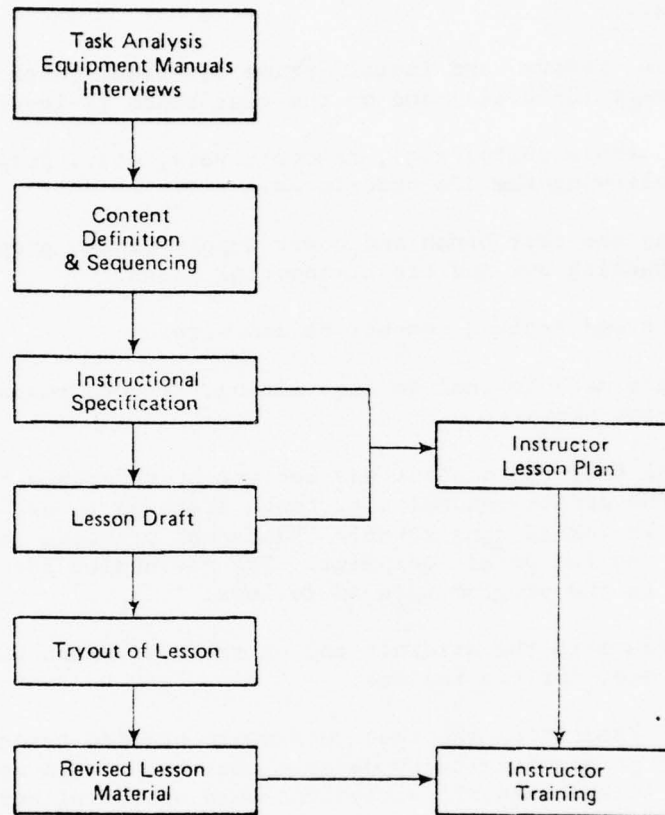

Figure A-13. Training Development Process

training program on Test Equipment and Tools. Similarly, inspection of the task analysis and the sample JPA indicated that, in order to follow the procedures to be included in the JPA, trainees would have to be able to:

1. Solder.
2. Locate, remove, and install prime equipment units in the aircraft (O-level); and on the test bench (I-level).
3. Disassemble units; e.g., remove covers, etc., preparatory to following the JPA procedures.
4. Set up the test bench and power supply bench, preparatory to checking out and troubleshooting units.
5. Repair and replace connectors and wire.

Thus, plans were made to include in training, lessons responsive to the five items listed above.

Additional training content was derived by reference to the overall objective of the program--namely, to teach trainees to use JPA. Plans were made for including considerable "hands-on" practice in the program, using the JPA and the prime equipment. The rationales for selecting JPA for inclusion in the program were as follows:

1. Checkouts in the aircraft and on the test bench were included, for two reasons:
  - a. Practicing the checkouts would provide trainees with an opportunity to observe what the system would "look like" when all subsystems were operating normally.
  - b. Without proficiency in performing the checkouts, it would be unlikely that trainees would become proficient in performing the JPA troubleshooting procedures.
2. Replacing digital readouts, switch and connector assemblies, and the CRT assembly, as well as certain routine "housekeeping" tasks would be included, because the procedures were short and easily followed by a novice. The intent here was to provide trainees with some quick and easy success in using JPA, and thus to (hopefully) build self-confidence in the trainees, as well as confidence in the JPA.
3. Troubleshooting practice with bugged equipment would be used because, in the final analysis, this was what the technicians' jobs were about. Two kinds of practices would be used--part-problem practices for "getting their feet wet," and whole-problem practices, which would be identical in all essentials to troubleshooting as it would be performed on the job.

4. Alignments and adjustments were to be included because of their extreme difficulty. Experience on earlier JPA projects, and the experience of our own technicians in aligning and adjusting the AQA-7 system led us to believe that if trainees could be taught to perform the alignments and adjustments, they would be just as proficient as most, and more proficient than many, of the technicians who were currently maintaining the system.

Additional training requirements were derived on the basis of examining the context in which the maintenance was to be performed--namely, the Navy. All trainees would eventually be required to do routine paper work as part of their jobs, and to know how to acquire parts, route equipment through the shop, etc. A decision was therefore made to include instruction in Navy Maintenance Procedures in the program.

Finally, a lesson was to be included entitled, "Introduction to Training and JPA." While this was to be primarily an orientation lesson, it would also include instruction on how to access and use information contained in the JPA.

#### Lesson Specifications

After general training requirements were derived as described above, a preliminary list of lesson titles was prepared. The list that evolved from the preliminary one is shown in Table A-1 below.

Table A-1

#### LESSON TITLES

##### INTRODUCTION TO TRAINING AND JPA

##### PRIME EQUIPMENT

- Locate Units in Aircraft
- Reference Designations
- Remove and Install Units
- Unit Disassembly (O-Level)
- Unit Disassembly (I-Level), including "Special Replacements"
- Navy Maintenance Procedures (O-Level)
- Navy Maintenance Procedures (I-Level)
- Test Bench
- Power Supply Bench
- Checkout in Aircraft
- Checkouts on Test Bench
- Part-Problem Practices (O-Level)
- Part-Problem Practices (I-Level)
- Whole-Problem Practices (O-Level)
- Whole-Problem Practices (I-Level)

Table A-1  
(cont)

TEST EQUIPMENT AND TOOLS

Multimeter (Simpson 260)  
Digital Voltmeter (Fluke 8300A)  
Differential Voltmeter (Fluke 931B)  
Scope (Tektronix 454)  
Hand Tools

SOLDERING

REPAIRS AND REPLACEMENTS

Connectors and Wire  
Digital Readouts  
Switch and Connector Assemblies  
CRT Assembly

ALIGNMENTS AND ADJUSTMENTS

FMS 10Hz Oscillator (FMS Coil)  
Spectrum Analyzer-Quantizer Subassemblies  
Demultiplexer  
DLC Resolver  
FMS Amplifier-Multiplier  
20 MHz Amplifiers  
SDR Power Supplies  
BFI Modules

HOUSEKEEPING

Air Filters  
CRT and Heat Sink  
SDR Subassemblies

Lesson specifications were developed for each of the lessons shown in Table 1. Each lesson specification contained sections on:

1. Overall Goals
2. Task Description References
3. Performance Outcomes
4. Performance Assessment
5. Training and Testing Materials
6. Minimal Practice Requirements
7. Instructional Procedure

Overall Goals. This section of each lesson specification contained a global statement of the behavior that the lesson is designed to elicit. It was a summary of entries in the action and output columns of the Task/Activity Descriptions.

Task/Activity Description References. This section was a list of the task and activity codes (from the Task/Activity Descriptions). The purpose of the section was to show which job-tasks and activities each lesson specification applies to.

Performance Outcomes. Entries in the "Performance Outcomes" sections of the lesson specifications were brief statements of the kinds of behavior that trainees will be capable of demonstrating at the end of the lesson. Essentially, these entries were objectives without: (a) statements of the conditions under which the behavior is to be demonstrated, and (b) criteria for acceptable performance. An example of a performance outcome for the Simpson 260 is, "Connect test leads to meter."

Performance Assessment. Whereas that "Performance Outcomes" sections of the lesson specifications were to indicate the kinds of behavior that trainees will demonstrate on completion of the lesson, the "Performance Assessment" sections specified the conditions under which the behavior is expected to occur, and criteria for acceptable performance. The general form of the entries in the "Performance Assessment" sections were, "Given ...(training and testing materials), trainees will...(statement of desired behavior), to...(criterion of mastery)." In essence, the "Performance Assessment" sections addressed the issue of how one might reliably discriminate between trainees who had, and trainees who had not, mastered the content of the lesson.

Together, the "Performance Assessment" and "Performance Outcomes" sections comprised what are usually called "behavioral objectives." The reason for separating the outcomes (behavior) from the conditions and criteria is to eliminate the step of "translating" objectives into test items: ultimately, we should be able to state objectives in terms of test items.

Training and Testing Materials. Most of the entries in this section of the specifications were derivable from the "input" and "action" columns of the Task/Activity Descriptions. These entries were supplemented with specifications for materials that would be needed for training and testing, but not necessarily for on-the-job performance; a VOM trainer, for example, or wall charts or slides.

Minimal Practice Requirements. This section summarized the kinds of practice required to promote efficient learning of the behavior of interest. Obviously, one cannot specify before tryout the optimal mix of practice that will ensure learning. Rather, the intent was to specify the kinds of practice without which learning the desired behavior would seem unlikely. Examples of the kinds of practice referred to here appear in a sample lesson specification attached (Figure A-14).

AQA-7 LESSON SPECIFICATION

LESSON TITLE: Tektronix 454 Oscilloscope

I x 0

PART 2 of 4: Procedures

OVERALL GOALS:

1. According to a prescribed sequence of operations:
  - a. Warm up the scope.
  - b. Get a trace on channel 1.
  - c. Center and focus the trace.
  - d. Get square waves.
  - e. Tune the probe.

PERFORMANCE OUTCOMES:

1. Using job aids (3" x 5" cards, listing control settings), perform procedures for doing items 1.a. through 1.e., above.  
(See attachment for procedures.)

PERFORMANCE ASSESSMENT:

1. Conditions: cover on scope, scope unplugged, controls "scrambled." Using the job aids, trainees set up the scope and perform the five procedures. Instructor uses checklist to rate the following as satisfactory or unsatisfactory.
  - a. Adherence to pre-plug in procedure.
  - b. Whether or not trainee gets linear trace.
  - c. Quality of centering and focusing.
  - d. Whether or not trainee gets square waves.
  - e. Flatness of square waves after trainee tunes probe..

Repeat procedure with remedial instruction to 100 percent mastery with probe tuned in less than three minutes.

Figure A-14. Sample Lesson Specification

TRAINING AND TESTING MATERIALS:

1. One, preferably two, scopes per four trainees.
2. Wall chart of scope front panel.
3. Instructional booklets (one per trainee).
4. Job aids, similar to attached, but plastic coated.

SUPPORT REQUIREMENTS:

1. Artwork for wall charts and instructional booklets.
2. Instructor to check responses and monitor testing.

INSTRUCTIONAL PROCEDURE: (See attached chart)

PREREQUISITES:

1. Lessons on:
  - a. System Introduction.
  - b. JPA Orientation.
  - c. Oscilloscope: Setup and Orientation.
2. This lesson is a prerequisite for:
  - a. Scope, Parts 3 & 4 JPA Standard Statements.
  - b. System Checkout (I-level).
  - c. Troubleshoot Units.
  - d. Adjustments.

MISCELLANEOUS NOTES:

1. Include "incidental" instruction on use of trace finder in this lesson.
2. Does this scope have an ASTIG adjustment? If so, include ASTIG adjustment if focus does not give focused display over entire trace length.

Figure A-14. Sample Lesson Specification  
(continued)

INSTRUCTOR LESSON PLAN

Lesson Title Scope - Part 2  
 Procedures \_\_\_\_\_  
 No. \_\_\_\_\_

		SUPPORT MATERIALS AND GUIDANCE	
	INSTRUCTIONAL PROCEDURE: Situation in which instruction will occur; student's actions, expected effect on student.	Method: Lecture/demonstration self-study Equipment: Scopes, with 10x probes	Instructional Guidance: After demonstration, minimal Media: Instruction book
EARLY STAGE	Instructor demonstration of procedures. Instruction booklet containing step-by-step procedures.	Method: Equipment:	Instructional Guidance: Media:
INTERMEDIATE		Method: Equipment:	Instructional Guidance: Media:
FINAL STAGE	Practice and testing: using job aids only (no books or pictures). Trainees set up scope and do the five procedures.	Method: Self-study Equipment: Scopes with probes	Instructional Guidance: Check responses, confirm or correct Media: Job aids

Figure A-14. Sample Lesson Specification (continued)

TEKTRONIX 454 OSCILLOSCOPE

Five Foolproof Procedures  
Guaranteed to:

1. Warmitup
2. Get a Trace on Channel 1
3. Center and Focus the Trace
4. Get Square Waves
5. Tune Your Probe

WARMITUP

(Procedure No. 1)

BEFORE PLUGGING IN

1. LVS set to match line voltage.
2. POWER to OFF.
3. INTENSITY to full counter-clockwise.

ACHTUNG! INTENSITY set past midrange may cause damage to scope!

4. PLUG IN (DO NOT turn on).  
---- then ----
5. INTENSITY to midrange
6. FOCUS to midrange
7. SCALE ILLUM to midrange
8.  $\uparrow$  POSITION (CH 1) to midrange
9.  $\leftarrow$  POSITION to midrange  
---- then ----
10. POWER to ON.

TRACE ON CHANNEL 1

(Procedure No. 2)

1. Warmitup, per Procedure No. 1  
---- then ----
2. MODE to CH 1
3. TRIGGER to NORM
4. A SWEEP MODE to AUTO TRIG
5. A AND B TIME/DIV to 0.5 us
6. A SWEEP LENGTH to FULL
7. HORIZ DISPLAY to A
8. MAG to OFF
9. A TRIGGERING SOURCE to INT

If no trace, increase INTENSITY  
ever so

G R A D U A L L Y

NADC-78286-60

Figure A-14. Sample Lesson Specification  
(continued)

SQUARE WAVES

TUNE YOUR PROBE  
(Procedure No. 5)

(Procedure No. 4)

1. Warmitup.
2. Get a trace on Channel 1.
3. Center and focus the trace (Procedure No. 3).

Tektronix 454 Scope

1. Warmitup.
2. Get a Trace on Channel 1.
3. Center and Focus the Trace.
4. Get some Square Waves (Procedure No. 4).

NADC-78286-60

---- then ----

5. Connect the BNC end of a 10x probe to INPUT CH 1.
6. Stick the probe tip in the hole of 1V CAL 1k Hz.
7. VOLTS/DIV CH 1 to 50 mv.
8. Tune the probe.

SQUARE WAVES

TUNE YOUR PROBE  
(Procedure No. 5)

(Procedure No. 4)

1. Warmitup.
2. Get a trace on Channel 1.
3. Center and focus the trace (Procedure No. 3).

Tektronix 454 Scope

1. Warmitup.
2. Get a Trace on Channel 1.
3. Center and Focus the Trace.
4. Get some Square Waves (Procedure No. 4).

NADC-78286-60

---- then ----

5. Connect the BNC end of a 10x probe to INPUT CH 1.
6. Stick the probe tip in the hole of 1V CAL 1k Hz.
7. VOLTS/DIV CH 1 to 50 mv.
8. Tune the probe.

CENTER AND FOCUS  
THE TRACE

(Procedure No. 3)

1. Warmitup.
2. Get a Trace on Ch 1 (Procedure No. 2).
3. Increase SCALE ILLUM until you can see the graticules.
4. Adjust  $\updownarrow$  POSITION (Ch 1) until the trace is centered on the middle horizontal line.
5. Adjust  $\leftrightarrow$  POSITION so that left end of trace just touches the left vertical graticule.
6. Adjust FOCUS for sharpest line.

---- then ----

4. Connect one end of a BNC-to-BNC jumper to 1V CAL 1k Hz.
5. Connect the other end of the jumper to INPUT CH 1.
6. VOLTS/DIV (CH 1) to 0.5.
7. INPUT CH 1 to AC.
8. A AND B TIME/DIV to 0.2 ms.

---- then ----

9. Adjust A TRIGGERING LEVEL until you've got square waves.
10. Center the trace vertically.
11. Center the trace horizontally.
12. Focus.
13. Check again and make sure the dashes are centered and focused.

Figure A-14. Sample Lesson Specification  
(continued)

Instructional Procedure. This section of each lesson specification described (generally at first and more specifically later) what the trainees and instructor(s) would be expected to do during each lesson, and served as a starting point for designing instructional materials and procedures. The "Instructional Procedures" sections of the lesson specifications should reflect adherence to principles of instructional technology--self-pacing, the use of job aids, instruction at the "point of need," etc.

As the project progressed, the specification contents were modified as follows:

1. Task/Activity Description References were deleted. These references were originally included to make sure that all lessons would have referents in the Task Analysis (Task/Activity Description). Early in the project it became obvious that this was indeed the case; that is, all of the Lesson Specifications did have referents in the Task Analysis. Once this was established, there was no need for formally identifying the task-analysis source for the Lesson Specifications.
2. The Minimal Practice Requirements sections were deleted, as information contained therein was redundant with information in the Instructional Procedure section.
3. A Support Requirements section was added, for making note of special materiel and personnel required for administering the lesson.
4. A standard form was used for summarizing the instructional procedure.

#### Lessons

Lessons were prepared for each of the titles shown in Table 1. The main information sources used in developing the lessons were the Lesson Specifications, the Task Analysis, and the JPA; and, for the test equipment lessons, users' manuals. In cases where these sources proved inadequate, technical assistance was obtained from the prime equipment manufacturer's representative and from electronics technicians involved in developing the JPA.

#### Tryouts

All lessons were reviewed, tried out, and revised on the basis of the tryout results. Reviewers and tryout subjects included secretaries, Navy recruits, technicians and scientists, Navy instructors, and the prime equipment manufacturer's representative.

Instructor Lesson Plans

In addition to the Lesson Specifications and Lessons, an Instructor Lesson Plan was prepared for each lesson shown in Table 1.

Each Lesson Plan contains sections entitled:

1. Overall Goals: a global statement of the lesson's objectives.
2. Brief: summary descriptions of trainee activities during the lesson.
3. Instructor Activity: descriptions of the instructors' roles in administering each lesson.
4. Performance Assessment: instructions for assessing trainees' mastery of lesson contents, and for providing any necessary remedial instruction.

The Instructor Lesson Plans were bound in a loose-leaf book which also contained:

1. A section entitled "Note to the Instructors." This section included:
  - a. A statement of the purpose of the training program.
  - b. Time estimates for administering each lesson.
  - c. Sequencing diagrams for the lessons, accompanied by explanatory text.
  - d. A section entitled "Using the Lesson Plans," which emphasizes that instructors should read the Lesson Plans and take each lesson, including the practice exercises and tests, before administering the program.
2. Performance tests, instructions for assessing performance for each lesson, or both.
3. Printed scripts of lessons that were prepared in audiotape form.

An example Instructor Lesson Plan follows (Figure A-15).

SCOPE (TEKTRONIX 454)

PART 1

Set Up and Orientation

OVERALL GOALS:

1. Set up the scope prior to warm up.
2. Identify major sections of scope.
3. State correspondence between knob and label colors.
4. According to a prescribed sequence of operations:
  - a. Warm up the scope.
  - b. Get a trace on Channel 1.
  - c. Center and focus the trace.
  - d. Get square waves.
  - e. Tune the probe.

BRIEF:

Trainee will read lesson guide and and perform the procedures, etc. given in the lesson. Trainee may seek instructor's aid at any time. Trainee will set up scope by: 1) removing the front cover and, 2) positioning the handle. Trainee will identify major sections of the scope by labeling on a diagram of the scope front panel the 5 major sections of the scope: Power, Calibration, Vertical Control, Horizontal Control, and Presentation. Trainee will demonstrate by filling in blanks in lesson guide that he knows that red labels correspond to red knobs, black labels to grey knobs. Trainee will use job aid "Procedure Cards" to perform the procedures for doing items 4a through 4e in the Goals listed above.

Figure A-15. Example Instructor Lesson Plan

INSTRUCTOR ACTIVITY:

Instructor may be asked:

1. To demonstrate how to remove cover and position handle at the beginning part of the lesson.
2. How to set LVS to match line voltage.
3. To check that trace gotten at end of Procedure 3 is satisfactory.
4. To help trainee get square waves, if trainee seeks instructor's aid.
5. To show trainee a 10 X probe and demonstrate how to connect it to Input Channel 1.
6. To demonstrate to trainees, the proper way to attach the probe tip to the jack labeled 1V Cal 1K Hz.
7. For help in getting square waves.
8. To demonstrate how to use the adjusting screw in the BNC end of the probe lead.

PERFORMANCE ASSESSMENT:

Testing will be done as part of performance assessment after completion of Part 2 exercises.

Conditions: cover on scope, scope unplugged, controls "scrambled." Using the job aids, trainees set up the scope and perform the five procedures.

Observe trainee for:

1. Adherence to pre-plug-in procedure.
2. Whether or not trainee gets linear trace.
3. Quality of centering and focusing.
4. Whether or not trainee gets square waves.
5. Flatness of square waves after trainee tunes probe.

Figure A-15. Example Instructor Lesson Plan  
(continued)

Repeat procedure with remedial instruction to 100 percent mastery with probe tuned in less than five minutes.

NOTE: In the course of preparing Job Performance Aids for the system checkout, we found that the efficiency of the checkout in the aircraft (O-Level) could be greatly increased by use of an Oscilloscope. Unfortunately, we discovered this too late to revise the lesson guides to show that O-Level, as well as I-Level, trainees should receive instruction in using the scope. Instructors should, therefore, adjust the training schedule to allow O-Level trainees to take the scope lesson. The lesson can be taken any time before the Multimeter, Locate Units in Aircraft, Navy Maintenance Procedures, Hand Tools, and Reference Designations Lessons.

Figure A-15. Example Instructor Lesson Plan  
(continued)

SCOPE (TEKTRONIX 454)

PART 2

Exercises in Learning to Make Perceptual Discriminations  
Between Scope Display and Exercise Pictures

OVERALL GOALS:

1. Interpret scope displays on the basis of practice exercises.  
Trainee learns to match the scope display to picture in exercise.

BRIEF:

Trainee will read lesson guide and perform the procedures given in the lesson. Trainee may seek instructor's aid at any time.

Trainee will be given the scope control settings, will connect test leads, make necessary adjustments, and match display to the one shown in the exercise.

INSTRUCTOR ACTIVITY:

Setups for Exercises

All three Scope Practice Sets must be hooked into the Eico wave generator for the exercises to work. It doesn't matter whether three trainees have a Practice Set in use or not.

Setting up the Practice Sets:

1. Connect the three grey wires to the red Sine terminal on the Eico.
2. Connect the three red wires to the red square terminal on the Eico.
3. Connect the three purple wires to the black terminal on the Eico.
4. Connect the other end of each grey wire to the white terminal on each Practice Set.

Figure A-15. Example Instructor Lesson Plan  
(continued)

5. Connect the other end of each red wire to the red terminal on each Practice Set.
6. Connect the other end of each purple wire to the black terminal on each Practice Set.
7. Space the Practice Sets as far apart as possible.

Eico Adjustments

Exercises 1-5: Once adjusted for Exercise No. 1, trainee can do the first exercises without further adjustments.

1. Set up a scope.
2. Turn power ON to Eico and warm up.
3. Set Eico Range on X10.
4. Set large round dial on Eico at about 10.
5. Connect scope Input (probe) to TP1 on the Practice Set.
6. Ground scope to GRND on Practice Set.
7. On the scope:
  - Set VOLTS/DIV Ch. 1 to .2
  - Set A and B TIME/DIV to 2ms
  - Set Input Ch. 1 to DC
  - Set A TRIGGERING SLOPE to +
8. Adjust the Output Level Square Waves dial on the Eico to get square waves that measure 15 divisions vertically.
9. Adjust the large round dial on the Eico until each square wave measures 25 divisions horizontally.
10. Remove probe and ground from Practice Set. Scramble scope settings.

Exercises 6-9: Trainees can do this group of exercises by changing the Eico range to X100. If there is a break between exercises, do the setup as above, then change Eico to range X100.

Exercises 10-15: Trainee can do this group of exercises by changing the Eico range to X1K. If there is a break between exercises, do the setup given above, then change the Eico range to X1K.

Figure A-15. Example Instructor Lesson Plan  
(continued)

Instructor may be asked for help at any time. Some possible helps:

1. Demonstrate how to connect scope ground to Practice Set ground.
2. Help in making position adjustments.
3. Questions concerning explanation of graticule and use of division marks.

Instructor will test trainee when trainee indicates he has completed Parts 1 and 2.

PERFORMANCE ASSESSMENT:

The test is in two parts, one for ability to use the procedure cards and set the scope up, and one for displaying waveforms and matching the display to the illustration.

Part 1 assessment: See conditions and description in Part 1 Lesson Plan.

Part 2 assessment: Set up Practice Sets and Eico as for the exercises (see Instructor Activity). Test requires trainee to display a waveform and match it to the illustration.

Any remedial instruction will consist of: 1) retaking the lesson or parts of it, or 2) instructor will tutor individual trainee concerning problem area.

Retraining and retesting will continue until the trainee can successfully pass the performance assessments.

NOTE: In the course of preparing Job Performance Aids for the system checkout, we found that the efficiency of the checkout in the aircraft (O-Level) could be greatly increased by use of an Oscilloscope. Unfortunately, we discovered this too late to revise the lesson guides to show that O-Level, as well as I-Level, trainees should receive instruction in using the scope. Instructors should, therefore, adjust the training schedule to allow O-Level trainees to take the scope lesson. The lesson can be taken any time before the Multimeter, Locate Units in Aircraft, Navy Maintenance Procedures, Hand Tools, and Reference Designations Lessons.

Figure A-15. Example Instructor Lesson Plan  
(continued)

## PERFORMANCE TEST

SCOPE (TEKTRONIX 454)

TRAINEE: \_\_\_\_\_

- Have Instructor set up EICO and Scope Practice Set for use.
- Set up scope--use Procedure Cards as needed.
- Make setup given for each of the 16 test setups.
- Find each displayed waveform and write the test setup number in the blank.

## PART 1

EICO RANGE should be set on X10. DO NOT CHANGE OTHER SETTINGS

<u>Test Setup No.</u>	<u>Test Setup No.</u>
1. TP5	4. TP6
VOLTS/DIV: .2	VOLTS/DIV: .2
TIME/DIV: 1 ms	TIME/DIV: 2 ms
2. TP2	5. TP3
VOLTS/DIV: .2	VOLTS/DIV: .2
TIME/DIV: 1 ms	TIME/DIV: 2 ms
3. TP4	6. TP1
VOLTS/DIV: .2	VOLTS/DIV: .2
TIME/DIV: 1 ms	TIME/DIV: 2 ms

Figure A-15. Example Instructor Lesson Plan  
(continued)

PART 1: WAVEFORMS

Find the waveform for the test setup.

Write the number of the test setup in the space.

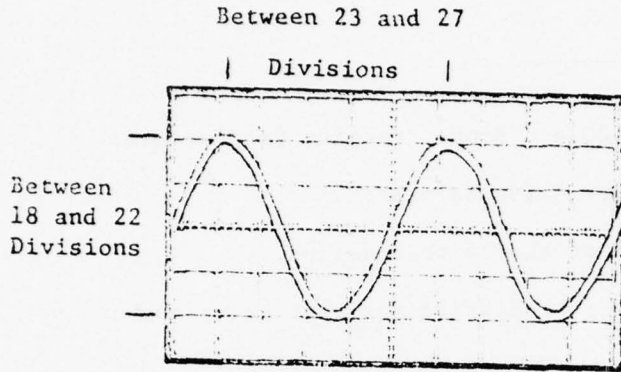

Test Setup No. \_\_\_\_\_

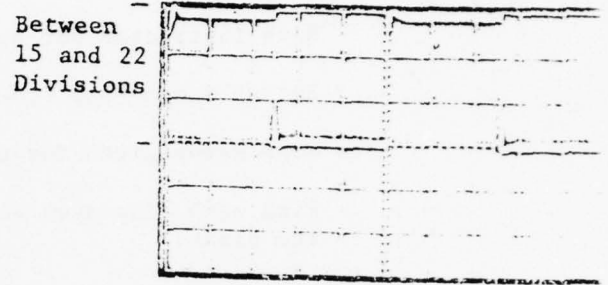

Test Setup No. \_\_\_\_\_

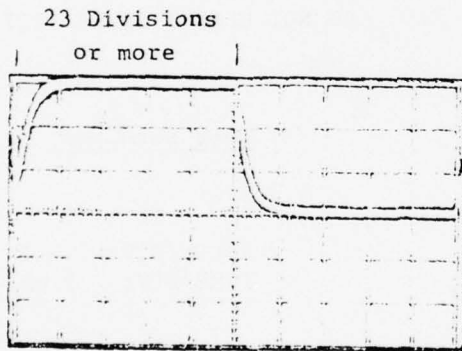

Test Setup No. \_\_\_\_\_

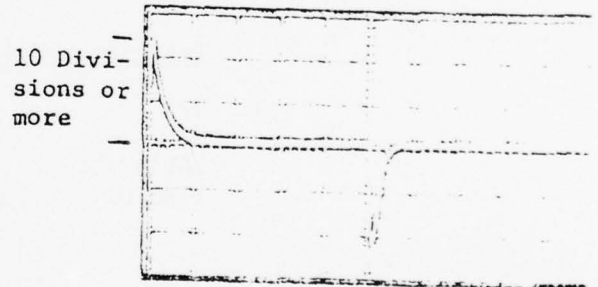

Test Setup No. \_\_\_\_\_

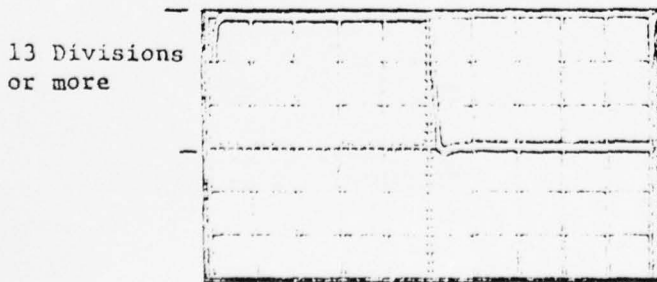

Test Setup No. \_\_\_\_\_

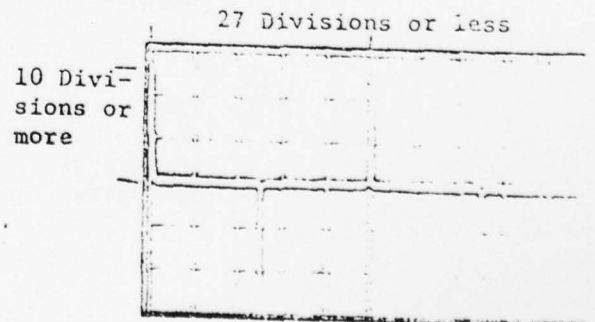

Test Setup No. \_\_\_\_\_

Figure A-15. Example Instructor Lesson Plan  
(continued)

PART 2: Change EICO RANGE to X100. DO NOT CHANGE OTHER SETTINGS.

<u>Test Setup No.</u>	<u>Test Setup No.</u>
7. TP4	10. TP3
VOLTS/DIV: .2	VOLTS/DIV: .2
TIME/DIV: .1 ms	TIME/DIV: .1 ms
8. TP2	11. TP5
VOLTS/DIV: .2	VOLTS/DIV: .2
TIME/DIV: .1 ms	TIME/DIV: .1 ms
9. TP1	
VOLTS/DIV: .2	
TIME/DIV: .2 ms	

Figure A-15. Example Instructor Lesson Plan  
(continued)

PART 2: WAVEFORMS

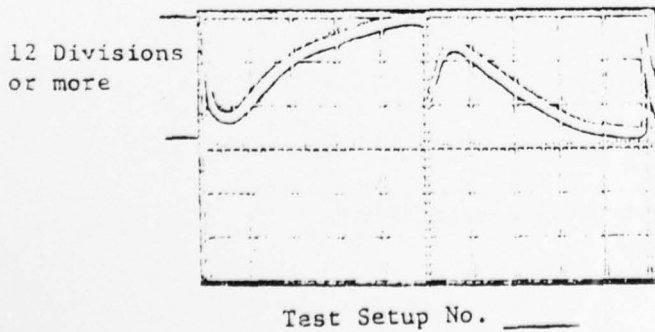
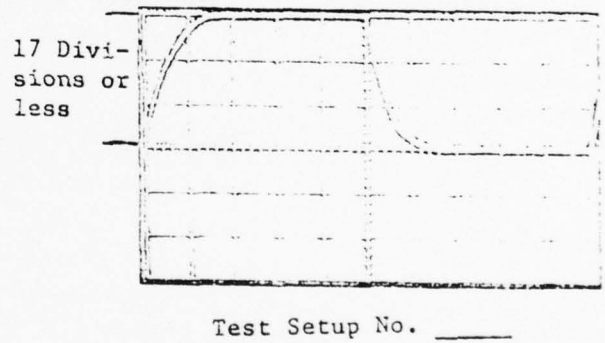
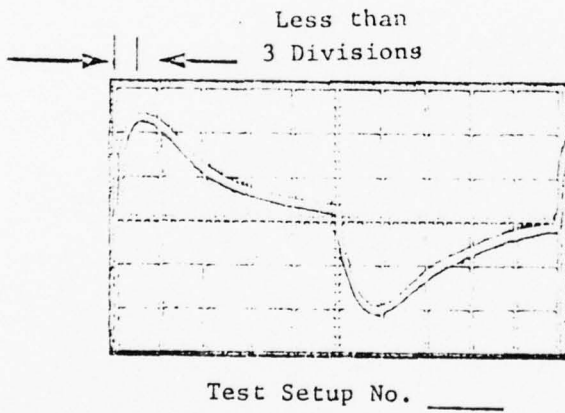
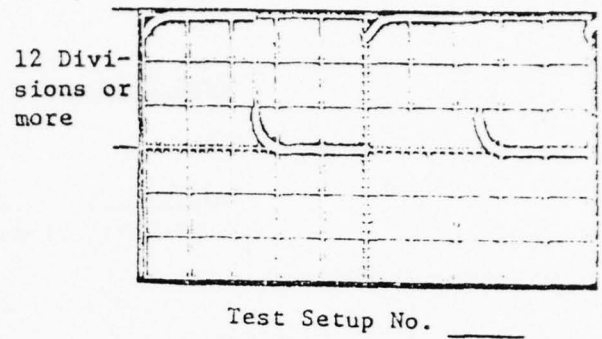
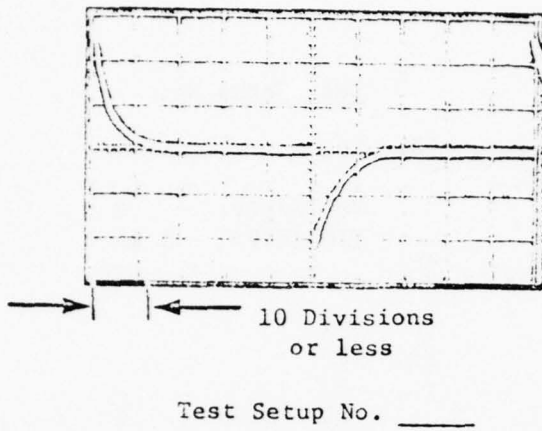

Figure A-15. Example Instructor Lesson Plan  
(continued)

PART 3: Change EICO RANGE to X1K. DO NOT CHANGE OTHER SETTINGS.

Test Setup No.

12. TP3  
VOLTS/DIV: .2  
TIME/DIV: 10  $\mu$ s

Test Setup No.

15. TP1  
VOLTS/DIV: .2  
TIME/DIV: 20  $\mu$ s

Test Setup No.

13. TP2  
VOLTS/DIV: .2  
TIME/DIV: 20  $\mu$ s

Test Setup No.

16. TP5  
VOLTS/DIV: .2  
TIME/DIV: 10  $\mu$ s

Test Setup No.

14. TP4  
VOLTS/DIV: .2  
TIME/DIV: 10  $\mu$ s

Figure A-15. Example Instructor Lesson Plan  
(continued)

PART 3: WAVEFORMS

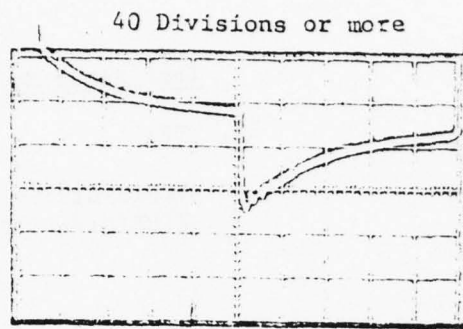

Test Setup No. \_\_\_\_\_

15 Divisions or less

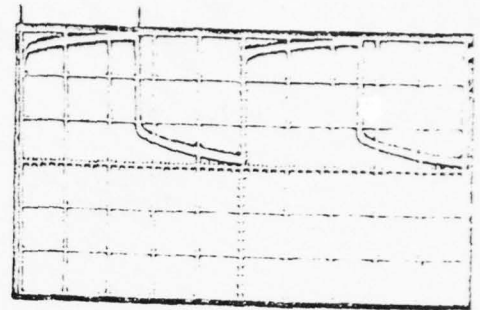

Test Setup No. \_\_\_\_\_

23 Divisions or more

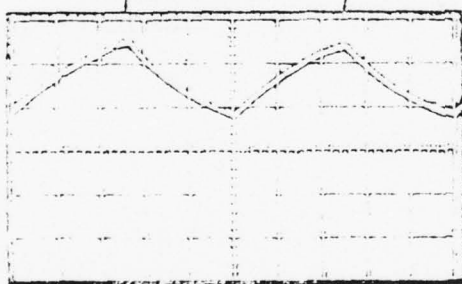

Test Setup No. \_\_\_\_\_

10 Divisions or more

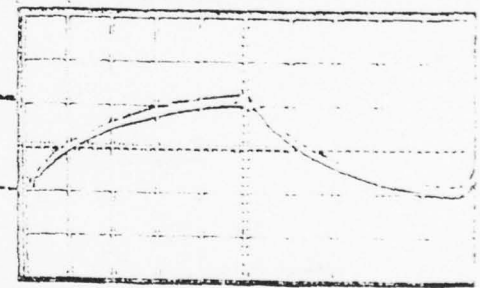

Test Setup No. \_\_\_\_\_

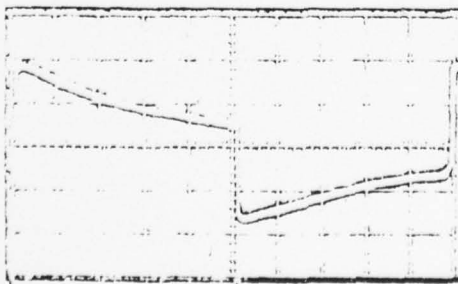

Between 23 and 27 Divisions

Test Setup No. \_\_\_\_\_

Figure A-15. Example Instructor Lesson Plan (continued)

NADC-78286-60

*APPENDIX B.* ASSESSMENT OF A JOB ORIENTED TRAINING PROGRAM IN SUPPORT  
OF FULLY PROCEDURALIZED JOB PERFORMANCE AIDS

By

Lieutenant Robert P. Fishburne, Jr., MSC, USNR

Formerly attached to  
Naval Technical Training Command  
Naval Air Station Memphis (75)  
Millington, Tennessee 38054

SUMMARY

Forty-one "A" school non-qualified recruit training graduates entered either Organizational ("O") or Intermediate ("I") level training for use of Fully Proceduralized Job Performance Aids (FPJPAs) in the maintenance of the AN/AQA-7 Sonar Recorder Group of the S2-G aircraft. The thirteen week "O" level and sixteen week "I" level training courses resulted in significant learning as measured by unit and comprehensive performance tests. Additionally, student responses to an attitudinal questionnaire were favorable for both groups. While these results appear to be positive, no definitive conclusions can be drawn until corresponding learning data is obtained from a control group under the traditional training pipeline for the AN/AQA-7 maintenance, and fleet performance data is obtained on both the experimental and control groups. Problems within the FPJPA training system, however, have been identified within the present study.

AD-A072 482

NAVAL AIR DEVELOPMENT CENTER WARMINSTER PA AIRCRAFT --ETC F/G 5/9  
APPLICATION AND EVALUATION OF FULLY PROCEDURALIZED JOB PERFORMA--ETC(U)  
DEC 78 C J THEISEN, T J ELLIOTT

UNCLASSIFIED

NADC-78286-60

NL

2 OF 2  
ADA  
072482



END  
DATE  
FILMED  
9-79  
DDC

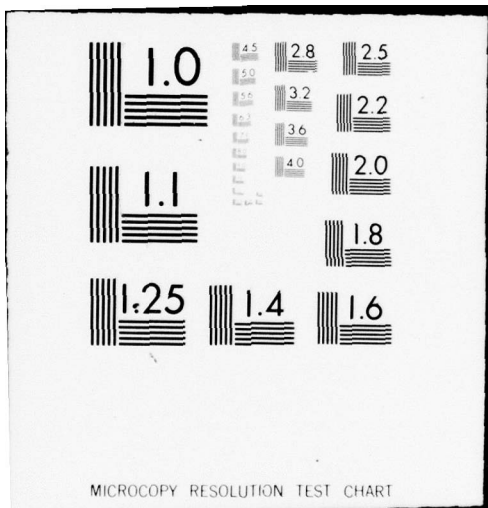

In January 1974, the Chief of Naval Technical Training undertook the task of evaluating the training portion of the NAVAIRDEVCECEN's integrated Job Performance Aids (FPJPAs). This evaluation involved the training of 15 graduates of recruit training who were destined to perform organizational maintenance ("O" level) of the AN/AQA-7 Sonar Recorder Group (installed in the S-2G aircraft), and 26 graduates of recruit training who would receive training to the intermediate level ("I" level) of maintenance of this same system. The "O" level training required approximately thirteen weeks, and the "I" level training required approximately sixteen weeks. Of the entry personnel, three "O" level and three "I" personnel were dismissed from the project for non-academic reasons.

As the subjects were selected for this experimental program on the basis of being non-qualified for the "A" schools (and therefore the further advanced training traditionally required for maintenance of the AN/AQA-7 system), the FPJPA training course and maintenance package were necessarily geared to this unskilled population.

The evaluation task was to provide technical monitoring of the training environment, appraisal of the training system and instructor training preparation, and an objective analysis of training effectiveness. To accomplish these objectives, a quantitative description of student entry behaviors was compiled as a starting point in developing a comprehensive appraisal of the training system. Table B-1 presents the mean Basic Test Battery scores and California Reading Test scores for both the "O" and "I" level subjects. Of particular interest are the "O" and "I" level GCT scores of 47.0 and 47.9 respectively. The California Reading Test scores ("O" level = 10.4, "I"

level = 9.9) are probably somewhat inflated due to that test's development and validation on the public school, rather than the Navy population. While the reading grade level of the individuals in the present study is certainly a critical factor in a system dependent upon precisely following directions in printed materials, its impact can only be assessed in relation to the readability of the FJPJAs. Tables B-2 and B-3 present the readability of the FPJPA training materials and maintenance manuals as determined by the Automated Readability Index (ARI) from a ten percent sample.

Table B-1

MEAN BASIC TEST BATTERY SCORES AND CALIFORNIA  
READING TEST SCORES FOR "O" AND "I" LEVEL CLASSES

BASIC TEST BATTERY								READING LEVEL
G	A	M	C	S	E	S	CA	
C	R	E	L	O	T	H		
T	I	C	E	N	S	O		
		H	R	A	T	P		
				R				
<b>"O" Level</b>								
$\bar{X}$	47.0	48.6	49.7	55.3	45.7	47.2	46.6	10.4
SD	3.0	3.5	4.1	8.5	16.6	5.5	4.7	1.5
<b>"I" Level</b>								
$\bar{X}$	47.9	46.7	47.9	53.1	54.6	49.1	48.9	9.9
SD	2.9	4.0	3.9	7.8	9.4	7.4	5.8	1.6

NADC-78286-60  
Table B-2

READABILITY OF FPJPA TRAINING MATERIALS

<u>COURSE UNIT</u>	<u>ARI GRADE LEVEL</u>
Multimeter	5.31
Differential Voltmeter	5.96
Digital Voltmeter	5.50
Scope	4.74
Unit Disassembly	6.06
Switch & Connector Assemblies	9.14
Digital Readouts	6.01
CRT Assemblies	7.67
Introduction to JPAs	9.45

Table B-3

READABILITY OF FPJPA MAINTENANCE MATERIALS

<u>ASA FILE NO.</u>	<u>ARI GRADE LEVEL</u>	<u>ASA FILE NO.</u>	<u>ARI GRADE LEVEL</u>
33	6.237	46	5.442
51	7.529	47	9.592
38	7.323	48	9.067
55	4.029	29	5.141
14	7.943	21	4.972
18	5.199	20	4.261
40B	5.870	24	4.125
41A	8.493	54	9.323
41B	7.190	22	3.908
41C	8.493	17	4.044
41D	8.493	28	5.776
41E	8.493	43A	8.342
41F	8.493	43B	8.914
41G	8.493	13	5.013
41H	8.317	39A	9.820
44	8.817	39B	11.654
45	4.516		

The ARI grade levels of the training course units appear to be well below the California Reading Test grade levels of both the "0" and "I" level students. Likewise, this is true in all but one sample of the FPJPA maintenance materials.

The measurement and evaluation of training course effectiveness resulting from the present study has been designed around the recording of individual performance scores on each JPA unit test within the course of study and on the final comprehensive JPA performance test. The final comprehensive test is further analyzed in terms of time to complete each problem and a breakdown of critical errors within these problems. Finally, this data is augmented by a questionnaire in the semantic differential format which was designed to elicit the opinions, attitudes, and experiences of both the instructors and students of the "0" and "I" level JPA classes. Additionally, this questionnaire incorporates a rating scheme concerning the perceived level of difficulty of each training course unit.

Table B-4 presents the mean "0" level performance scores on those JPA unit tests in which percentage grading was compatible. These training course units are as follows: Reference Designations, Unit Disassembly, Multimeter Progress, Multimeter Performance, and Scope. The lowest mean score (77.21) in this series appears in the Multimeter Performance Unit.

Table B-4

MEAN "O" LEVEL PERFORMANCE SCORES ON JPA UNIT TESTS  
(Percent Correct)

Reference Designations		Unit Disassembly	Multimeter Progress			Multimeter Performance	Scope
Part A	Part B		Part A	Part B	Part C		
97.55	100.00	100.00	87.33	84.67	89.33	77.21	96.83
4.87	--	--	22.82	23.26	11.00	10.66	6.97

Tables B-5 and B-6 present the mean "I" level Class A and Class B performance scores on the following unit tests: Reference Designations, Unit Disassembly, Multimeter Performance, Differential Voltmeter, Digital Voltmeter, Test Bench, and Scope. Low mean scores appear only on Part A of the Test Bench unit test in Class A (78.00) and on Part A of the Multimeter Progress test in Class B (70.00).

Table B-5

MEAN "I" LEVEL (A) PERFORMANCE SCORES ON JPA UNIT TESTS  
(Percent Correct)

Reference Designations		Unit Disassembly	Multimeter Performance	Differential Voltmeter
Part A	Part B			
98.14	100.00	100.00	88.16	91.21
2.34	--	--	8.29	17.78

Digital Voltmeter	Test Bench				Scope
	Part A	Part B	Part C	Part D	
93.85	78.00	98.18	100.00	93.18	96.12
7.68	14.76	6.03	--	11.63	10.82

Table B-6

MEAN "I" LEVEL (B) PERFORMANCE SCORES ON JPA UNIT TESTS  
(Percent Correct)

Designations		Unit Disassembly	Multimeter Progress			Multimeter Performance
Part A	Part B		Part A	Part B	Part C	
90.38	100.00	100.00	70.00	88.33	90.00	79.13
24.62	--	--	6.32	11.69	10.95	11.48

Differential Voltmeter	Part A	Test Bench			Scope
		Part B	Part C	Part D	
100.00	100.00	97.50	100.00	100.00	94.23
--	--	7.70	--	--	10.96

The formal evaluative tryout concerning the FPJPAs was started after these JOT programs were completed. A description and performance data regarding this tryout are found in the body of this report. In addition to the task success and time data found in Tables 1 and 2 of the body of the report, the following "Critical Error Diagnoses" were made to identify possible training and FPJPA deficiencies. A "critical error" as defined here is an incorrect response or deviation from the correct FPJPA maintenance path causing failure of a problem trial by two or more subjects. Tables B-7 and B-8 present the critical error analysis for the "O" and "I" levels respectively. Within the "O" level problems, the most frequent critical errors occurred in steps 498 - 499 (tasks = set switch, check waveform) and 257 - 258 (task = check indications) of problem 1A1, step 278 and 5845 (tasks = depress tile and discriminate, check traces) of problem 4A2, and step 278 (task = depress tile and discriminate) of problem FMS#2. For the "I" level, the most frequent critical errors occurred in steps 7 and 39 (tasks = check indication (DVM), check waveform) of problem 6A4, steps 16-20 (tasks = set switch, adjust (delaytime multiplier), adjust (R9) of problem 4A2, and steps 23-26 (tasks = set switch, adjust (OVV SIG)) of problem 11A3.

## CRITICAL ERROR ANALYSIS FOR ALL "O" LEVEL Ss

<u>Problem</u>	<u>Step Number</u>	<u>Task</u>	<u>JPA Passage</u>	<u>% Ss Making Critical Error</u>
1A1	248	Check printouts (SDR)	Check that SDR printouts are similar to (10). If not, go to step 3102.	18.2
	498	Set switch	Set VOLTS/DIV switch to .5. Set TIME/DIV switch to .1 ms. Set TRIGGERING SOURCE to INT.	45.5
	499	Check waveform	Check that displayed waveform is similar to (10). If not, go to step 508.	
	257	Check indications	200 seconds between 257 and 261 degrees. 300 seconds between 259 and 260 degrees.	45.5
	258	Check indications	Check that recorded indications and listed indications of step 255 through step 257 agree. If not, repeat step 253 through 257 once. If indications do not agree the second time, go to step 3141.	
	259	Check printouts (SDR)	Check that SDR printouts are similar to (14). If not, go to step 3203.	
4A2	258	Check indications	Check that recorded indications and listed indications of step 255 through step 257 agree. If not, repeat step 253 through 257 once. If indications do not agree the second time, go to step 3141.	16.7
	259	Check printouts (SDR)	Check that SDR printouts are similar to (14). If not, go to step 3203.	
	278	Depress tile and discriminate	Alternately depress MOVE RIGHT tile (17) and MOVE LEFT tile (18) until BFI display is similar to (33). If unable to obtain display, go to step 5845.	83.3

## NADC-78286-60

<u>Problem</u>	<u>Step Number</u>	<u>Task</u>	<u>JPA Passage</u>	<u>% Ss Making Critical Error</u>
4A2	5845	Check Traces	Check that Traces A, B, C, and D are not similar to (1). If any are similar, go to step 5845.	
19A2	234	Check display (BFI)	Check that BFI display is similar to (5). If not, go to step 5023.	33.3
	5025	Check waveform	Check that displayed waveform is the same as (1). If not, replace SIGNAL DATA RECORDER RO-396 (10); go to step 1.	25.0
	5028	Check display	Check that BFI display is similar to (9). If not, go to step 5037.	16.7
	5035	Check display (BFI)	Check that BFI display is similar to (9). If not, go to step 5045.	25.0
FMS#2	278	Depress tile and discriminate	Alternately depress MOVE RIGHT tile (17) and MOVE LEFT tile (18) until BFI display is similar to (33). If unable to obtain display, go to step 5845.	90.0
	5845	Check Traces	Check that Traces A, B, C, and D are not similar to (1). If any are similar, go to step 5845.	
	5895	Check Trace	Check that Trace C is similar to (8). If not, go to step 5908.	20.0
20A1	1021	Check indication (multimeter)	Check that multimeter indicates between 110 VAC and 120 VAC. If not, go to step 1229.	16.7

\* Critical Error = Significant error or deviation from correct JPA maintenance path causing failure of a problem trial by two or more Ss.

NADC-78286-60

Table B-8

CRITICAL ERROR ANALYSIS FOR ALL "I" LEVEL Ss

<u>Problem</u>	<u>Step Number</u>	<u>Task</u>	<u>JPA Passage</u>	<u>% Ss Making Critical Error</u>
PP6306	22	Check indicator (115 VAC)	Check that 115 VAC indicator (3) is not lit. If lit, go to step 730.	9.0
	733	Check indicator (115 VAC)	Check that 115 VAC indicator (3) is not lit. If lit, go to step 735.	13.6
6A4	7	Check indication (DVM)	Check that DVM indicates between 7.9M and 8.1M ohms. If not, go to step 72.	21.7
	9	Check indication (DVM)	Check that DVM indicates 50 K ohms or more. If not, replace 6A4A1C22 (22); go to step 1.	8.7
	39	Check waveform	Check that displayed waveform is similar to (8). If not, go to step 139.	21.7
	139	Adjust (6A4 Video Amplifier)	Perform 6A4 Video Amplifier; adjust (Vol. NADC-CSM-74010, p. 5-1).	
	140	Check adjustment	Check that adjustment was successful. If not, go to step 142.	
4A2	9	Adjust (R4)	Adjust R4 (11) until displayed waveform is similar to (10).	13.0
	16	Connect (scope)	Using Tektronix 454, connect input to A2J11 (3). Connect probe ground to A2J1 (4). Connect EXT TRIG INPUT to A1J11 (5).	56.5
	17	Set switch	Set VOLTS/DIV switch to .2. Set TIME/DIV switch to 20 mS. Set TRIGGERING SOURCE to EXT.	

\* Critical Error = Significant error or deviation from correct JPA maintenance path causing failure of a problem trial by two or more Ss.

<u>Problem</u>	<u>Step Number</u>	<u>Task</u>	<u>JPA Passage</u>	<u>% Ss Making Critical Error</u>
4A2	18	Set switch	Set HORIZ DISPLAY switch to A INTEN DURING B. Set DELAYED SWEEP control to 2 mS. Set B SWEEP MODE switch to B - STARTS AFTER DELAYTIME. Set A SWEEP MODE switch to NORM TRIG.	
	19	Adjust (Delaytime multiplier)	Adjust DELAYTIME MULTIPLIER control until brightened portion of sweep is centered over pulse (6).	
	20	Set switch	Set HORIZ DISPLAY switch to B (DELAYED/SWEEP).	
	22	Adjust (R9)	Adjust R9 (9) until pulse (14) reaches maximum negative peak.	8.7
11A3	23	Set switch	Set DVM SELECT switch (15) to 11A3 SIG.	23.8
	24	Set switch	Set 11A3 TEST switch (1) to 31V.	
	25	Adjust (OVV SIG)	Adjust OVV SIG ADJUST 11A3 (2) until DVM indicates 0 VDC.	
	26	Set switch (DVM Select)	Set DVM SELECT switch (3) to 11A3 OV CUR.	

\* Critical Error = Significant error or deviation from correct JPA maintenance path causing failure of a problem trial by two or more Ss.

Student responses to the JPA Training Course Questionnaire are presented in Appendices B-A and B-B. "O" and "I" level responses in general indicated the following:

- Student like the overall JPA Training Course a lot
- Students felt they learned a lot from the JPA Training Course
- Students found the written materials easy to understand
- Students found the JPA pictures to be relatively easy to follow
- Students needed the instructor to explain the written instructions a few times
- Students found that some of the training material was wrong more than a few times for the "O" level and often for the "I" level
- Students neither liked nor disliked not getting any theory in the course
- Students like a lot the idea of using JPA books for all maintenance task work
- Students felt that the right amount of time was spent on each part of the course
- Students think this course will help them advance in rate but many are unsure, especially in the "I" level
- Students like a lot the following of JPA directions instead of making maintenance decisions at the "O" level and a little at the "I" level
- Students indicated that this JPA Training Course helped a lot in learning to follow JPA direction
- Students indicated that the JPA training materials did not seem to get harder toward the end of the course
- Students indicated that equipment problems kept them from working a little of the time
- Students indicated that the organization of the JPA training course was O.K.
- Students indicated that their instructor was very helpful in the "O" level and more than helpful at the "I" level

NADC-78286-60

- Students felt that the right amount of time was spent on working with the actual equipment rather than studying books
- Students would recommend JPA training for all basic electronics maintenance courses
- Students are not sure whether they plan to make a career in the Navy
- Students feel that this JPA Training Course will help them to be a useful part of the Navy maintenance team

NADC-78286-60

Tables B-9 and B-10 present the "O" and "I" level student's rating of the difficulty of the JPA Training Course Units. At the "O" level, only one course unit, "Multimeter," was rated as being hard by more than ten percent of the respondents. At the "I" level, however, eleven course units were rated as being hard by more than ten percent of the respondents. They are as follows: "Miniature Repair," "Multimeter," "Differential Voltmeter," "Navy Maintenance Procedures," "SDR Sub-assemblies," "CRT and Heat Sink," "Connectors and Wires," "Part-Problem Practices," "Alignments and Adjustments," "Digital Readouts," and "CRT Assembly."

Table B-9

"O" LEVEL STUDENTS' RATING OF TRAINING COURSE UNITS

(Mean Percentage Per Category)

<u>Course Unit</u>	<u>Very Easy</u>	<u>Easy</u>	<u>Hard</u>	<u>Very Hard</u>
Introduction to Training and JPA	55	36	9	0
Multimeter	9	64	27	0
Locate Units in Aircraft	73	27	0	0
Navy Maintenance Procedures	18	82	0	0
Hand Tools	27	73	0	0
Reference Designations	45	45	9	0
Remove and Install Units				
Air Filters	91	9	0	0
Unit Disassembly	55	45	0	0
Connectors and Wires	18	73	9	0
Checkout in Aircraft	36	64	0	0
Switch and Connector Assemblies	55	45	0	0
Digital Readouts	45	45	9	0
Part - Problem Practices	27	64	9	0
Whole Problem Practices	27	64	9	0

Table B-10

## "I" LEVEL STUDENTS' RATING OF TRAINING COURSE UNITS

(Mean Percentage Per Category)

<u>Course Unit</u>	<u>Very Easy</u>	<u>Easy</u>	<u>Hard</u>	<u>Very Hard</u>
Introduction to Training and JPA	48	52	0	0
Miniature Repair (Soldering)	17	9	52	22
Multimeter	13	74	13	0
Differential Voltmeter	13	65	22	0
Digital Voltmeter	48	43	9	0
Scope	13	78	9	0
Hand Tools	64	32	4	0
Reference Designations	26	61	9	4
Navy Maintenance Procedures	9	64	27	0
Unit Disassembly	45	50	5	0
Test Bench	26	65	9	0
Air Filters	86	14	0	0
SDR Sub-assemblies	13	70	17	0
CRT and Heat Sink	24	52	24	0
Connectors and Wires	26	57	17	0
Checkouts on Test Bench	19	75	6	0
Power Supply Bench	9	82	9	0
Part - Problem Practices	10	75	15	0
Alignments and Adjustments	22	65	13	0
Digital Readouts	31	52	13	4
Switch and Connector Assemblies	27	68	5	0
CRT Assembly	9	68	23	0
Whole Problem Practices	19	76	5	0

NADC-78286-60

Individual responses of each instructor to the JPA Training Course Questionnaire are provided for comparative purposes in Tables B-11, B-12 and B-13. The "O" level instructor rated "Whole Problem Practices," only as being hard. "I" level instructor (A) rated "Multimeter," "Scope," "Checkouts on Test Bench," "Power Supply Bench," and "Alignments and Adjustments" as being hard, while "I" level instructor (B) only rated "Whole Problem Practices" as hard.

Table B-11

"O" LEVEL INSTRUCTOR'S RATING OF TRAINING COURSE UNITS

<u>Very Easy</u>	<u>Easy</u>	<u>Hard</u>	<u>Very Hard</u>
Multimeter	Locate Units in Aircraft	Whole Problem Practices	
Hand Tools	Checkout in Aircraft		
Reference Designations			
Remove and Install Units			
Air Filters			
Unit Disassembly			
Digital Readouts			
<u>Not Available</u>	Introduction to Training and JPA, Navy Maintenance Procedures, Connectors and Wire, Switch and Connector Assemblies, and Part - Problem Practices		

Table B-12

"I" LEVEL INSTRUCTOR (A)'s RATING OF TRAINING COURSE UNITS

<u>Very Easy</u>	<u>Easy</u>	<u>Hard</u>	<u>Very Hard</u>
Introduction to Training and JPA	Differential Voltmeter	Multimeter	Miniature Repa
Digital Voltmeter	SDR Sub-assemblies	Scope	Navy Maintenance Procedures
Hand Tools			
Reference Designations	CRT and Heat Sink	Checkouts on Test Bench	
Unit Disassembly			
Test Bench	Connectors and Wires	Power Supply Bench	
Air Filters		Alignments and Adjustments	
Digital Readouts			
Switch and Connector Assemblies			
CRT Assembly			
<u>Not Available</u>	Part-Problem Practices	Whole Problem Practices	

Table B-13

"I" LEVEL INSTRUCTOR (B)'s RATING OF TRAINING COURSE UNITS

<u>Very Easy</u>	<u>Easy</u>	<u>Hard</u>	<u>Very Hard</u>
Introduction to Training and JPA	Multimeter	Whole Problem Practices	Miniature Repair
Digital Voltmeter	Differential Voltmeter		Navy Maintenance Procedures
Hand Tools	Scope		
Reference Designations	Unit Disassembly		
Air Filters	Test Bench		
Digital Readouts	SDR Sub-assemblies		
Switch and Connector Assemblies	CRT and Heat Sink		
	Checkouts on Test Bench		
	Alignments and Adjustments		
	CRT Assembly		
<u>Not Available</u>	Part-Problem Practices	Connectors and Wire	

## OBSERVATIONS AND CONCLUSIONS

The present evaluation has necessarily centered upon a quantitative description of the "O" and "I" level JPA training course performances and attitudes of a sample of medium mental group, "A" school non-qualified personnel. While the resulting data is of value in terms of criterion performance assessment and within-course problem identification, the absence of a control group prevents a further comparative analysis at this time. Accordingly, the following observations have emerged:

- (1) The mean GCT + ARI + MECH Basic Test Battery Combination for the "O" and "I" level sample places these individuals in the Mental Group IIIB category.
- (2) The readability of the JPA training materials and maintenance manuals appears to be well below that which is required for the present sample.
- (3) JPA Unit Test means (percentage correct) indicate satisfactory learning (85 percent and above) for all "O" level units except the Multimeter Performance Unit (77.21 percent) and all "I" level units except the Test Bench Unit (78.00 percent on Part A), the Multimeter Performance Unit (79.13 percent), and the Multimeter Progress Unit (70.00 percent on Part A).
- (4) JPA Comprehensive Test means (percentage completed) indicate significant learning (90 percent and above) for all "O" level problems except the 4A1 (57.5 percent). "I" level performance means are significantly lower with three problems scoring below 90 percent (6A4 = 88.4%, 4A2 = 68.2%, 11A3 = 79.6%).

NOTE: (While significant learning has been demonstrated within the "O" level problem solving and to a lesser extent within the "I" level

problem solving, it must be recognized that the value of this learning can only be in reference to the criterion which may be as high as 100 percent in an actual maintenance situation.)

(5) The mean amount of time required for satisfactory completion of the "0" level problems was approximately one-half the sixty minutes that were permitted, while the "I" level problems required approximately 80 percent of this time.

(6) The "Critical Error Diagnoses" and a review of observer comments suggest that the training problem areas primarily involve the following of directions, the use of the scope, and signal discriminations.

(7) The weaknesses in following directions could have possibly been due to inadequate cues in the directions for the target population and/or to an inadequate understanding by members of this population of some of the action verbs used in the directions. A complete "hands on" verification of the FPJPAs using subjects from the target population would identify most cueing weaknesses. A training package concerning the meaning of action verbs together with a test on their meaning would ensure adequate understanding of FPJPA standard verbs.

(8) Under current JOT/FPJPA tradeoff rules both use of the oscilloscope and signal discriminations are usually assigned to JOT. However an improvement in signal discrimination could possibly be obtained by more effective cues in the FPJPA. Perhaps directions for some seldom used and difficult functions of the oscilloscope should be included in FPJPA.

(9) Student attitudinal responses for the "0" and "I" level groups are generally favorable and not significantly different.

(10) "O" level students and their instructor rated only one course unit as being hard, while a number of "I" level students identified nearly half of their course units as such. "I" level instructors, however, rated only from one to four course units as hard.

(11) The JPA Training Course effectiveness and efficiency may have been significantly reduced due to delays in curriculum delivery, errors in curriculum materials, inadequate testing instruments, lack of instructor training on JPA technology and a shortage of test equipment.

(12) The JPA training course required 13 weeks for the "O" level and 16 weeks for the "I" level. The standard pipeline for maintenance of the AN-AQA-7 requires approximately 22 weeks of training for qualification in the AX rating, followed by two weeks of "O" level and 14 weeks of "I" level training in the NAMTRADET. Thus, the JPA Training Course time and costs are significantly lower than that of the "A" and "C" school graduate who normally performs the same functions.

(13) A more comprehensive evaluation of the JPA training technology as employed in the present study will require performance test data from a control group of students graduating from the traditional training pipeline and an analysis of job performance feedback.

## Appendix B-A

## "O" LEVEL STUDENT RESPONSES TO JPA TRAINING COURSE QUESTIONNAIRE

Questionnaire Item	Response Alternatives	# of Respondents Per Category	% of Respondent Per Category
1. How do you feel about the overall JPA Training Course?	A. Liked a lot	8	73
	B. Liked a little	3	27
	C. Neither liked nor disliked	0	0
	D. Disliked a lot	0	0
2. How much do feel you learned from the JPA Training Course?	A. A lot	10	91
	B. A little	1	9
	C. Hardly anything	0	0
	D. Nothing at all	0	0
3. How difficult were the written materials for you to understand?	A. Very easy	2	18
	B. Easy	7	64
	C. Neither easy nor hard	1	9
	D. A little hard	1	9
	E. Very hard	0	0
4. How difficult to follow were the JPA pictures?	A. Very easy	3	27
	B. Easy	4	37
	C. Neither easy nor hard	3	27
	D. A little hard	1	9
	E. Very hard	0	0
5. How often did you need the instructor to explain the written instructions?	A. Very often	0	0
	B. Often	1	9
	C. A few times	10	91
	D. Never	0	0
6. How often did you find that some of your training material was wrong?	A. Very often	0	0
	B. Often	4	37
	C. A few times	7	63
	D. Never	0	0
7. How did you feel about not getting any theory in this course?	A. Like a lot	1	9
	B. Like a little	1	9
	C. Neither like nor dislike	8	73
	D. Dislike a little	1	9
	E. Dislike a lot	0	0
8. How do you feel about using JPA books for all your maintenance task work?	A. Like a lot	9	82
	B. Like a little	1	9
	C. Neither like nor dislike	1	9
	D. Dislike a little	0	0
	E. Dislike a lot	0	0

Questionnaire Item	Response Alternatives	# of Respondents Per Category	% of Respondent Per Category
9. How did you feel about the time spent on each part of the course?	A. Too much time	1	9
	B. Right amount of time	9	82
	C. Not enough time	1	9
10. Do you think this course will help you to advance in rate?	A. Yes	6	55
	B. Not sure	4	36
	C. No	1	9
11. How do you feel about following JPA directions instead of making your own maintenance decisions?	A. Like a lot	8	73
	B. Like a little	1	9
	C. Neither like nor dislike	2	18
	D. Dislike a little	0	0
	E. Dislike a lot	0	0
12. How much did this JPA Training Course help you to learn to follow JPA directions?	A. A lot	10	91
	B. A little	1	9
	C. Hardly any	0	0
	D. Not at all	0	0
13. Did the JPA training materials seem to get harder toward the end of the course?	A. Yes	2	18
	B. No	9	82
14. How often did equipment problems keep you from working?	A. A lot	1	9
	B. A little	7	64
	C. Hardly ever	3	27
	D. Never	0	0
15. How well did the JPA Training Course seem to be organized?	A. Very well	2	18
	B. O.K.	7	64
	C. Poorly	2	18
16. How helpful was your instructor to you?	A. Very helpful	11	100
	B. Helpful	0	0
	C. Not helpful	0	0
17. How do you feel about the amount of time spent on working with the actual equipment rather than studying books?	A. Too much time	1	9
	B. Right amount of time	10	91
	C. Not enough time	0	0
18. Would you recommend JPA training for all basic electronics maintenance courses?	A. Yes	8	73
	B. Not sure	3	27
	C. No	0	0

<u>Questionnaire Item</u>	<u>Response Alternatives</u>	<u># of Respondents Per Category</u>	<u>% of Respondents Per Category</u>
19. Do you plan to make a career of the Navy?	A. Yes	0	0
	B. Not sure	8	73
	C. No	3	27
20. Do you feel that this JPA Training Course will help you be a useful part of the Navy maintenance team?	A. Yes	10	91
	B. Not sure	1	9
	C. No	0	0

## "I" LEVEL STUDENT RESPONSES TO JPA TRAINING COURSE QUESTIONNAIRE

Questionnaire Item	Response Alternatives	# of Respondents Per Category	% of Respondents Per Category
1. How do you feel about the overall JPA Training Course?	A. Liked a lot	16	70
	B. Liked a little	3	13
	C. Neither liked nor disliked	2	9
	D. Disliked a little	1	4
	E. Disliked a lot	1	4
2. How much do you feel you learned from the JPA Training Course?	A. A lot	18	78
	B. A little	4	18
	C. Hardly anything	1	4
	D. Nothing at all	0	0
3. How difficult were the written materials for you to understand?	A. Very easy	4	17
	B. Easy	10	44
	C. Neither easy nor hard	6	26
	D. A little hard	3	13
	E. Very hard	0	0
4. How difficult to follow were the JPA pictures?	A. Very easy	5	22
	B. Easy	15	65
	C. Neither easy nor hard	2	9
	D. A little hard	1	4
	E. Very hard	0	0
5. How often did you need the instructor to explain the written instructions?	A. Very often	1	4
	B. Often	4	18
	C. A few times	18	78
	D. Never	0	0
6. How often did you find that some of your training material was wrong?	A. Very often	7	32
	B. Often	11	50
	C. A few times	4	18
	D. Never	0	0
7. How did you feel about not getting any theory in this course?	A. Like a lot	3	13
	B. Like a little	2	9
	C. Neither like nor dislike	5	22
	D. Dislike a little	7	30
	E. Dislike a lot	6	26
8. How do you feel about using JPA books for all your maintenance task work?	A. Like a lot	11	47
	B. Like a little	5	22
	C. Neither like nor dislike	2	9
	D. Dislike a little	5	22
	E. Dislike a lot	0	0

NADC-78286-60

Questionnaire Item	Response Alternatives	# of Respondents Per Category	% of Respondents Per Category
9. How did you feel about the time spent on each part of the course?	A. Too much time	1	4
	B. Right amount of time	17	74
	C. Not enough time	5	22
10. Do you think this course will help you to advance in rate?	A. Yes	8	35
	B. Not sure	13	57
	C. No	2	8
11. How do you feel about following JPA directions instead of making your own maintenance decisions?	A. Like a lot	8	35
	B. Like a little	7	30
	C. Neither like nor dislike	5	22
	D. Dislike a little	1	4
	E. Dislike a lot	2	9
12. How much did this JPA Training Course help you learn to follow JPA directions?	A. A lot	17	74
	B. A little	5	22
	C. Hardly any	0	0
	D. Not at all	1	4
13. Did the JPA training materials seem to get harder toward the end of the course?	A. Yes	1	4
	B. No	22	96
14. How often did equipment problems keep you from working?	A. A lot	8	35
	B. A little	11	48
	C. Hardly ever	4	17
	D. Never	0	0
15. How well did the JPA Training Course seem to be organized?	A. Very well	2	9
	B. O.K.	17	77
	C. Poorly	3	14
16. How helpful was your instructor to you?	A. Very helpful	10	45
	B. Helpful	10	45
	C. Not helpful	2	10
17. How do you feel about the amount of time spent on working with the actual equipment rather than studying books?	A. Too much time	0	0
	B. Right amount of time	16	70
	C. Not enough time	7	30
18. Would you recommend JPA training for all basic electronics maintenance courses?	A. Yes	16	70
	B. Not sure	5	22
	C. No	2	8

<u>Questionnaire Item</u>	<u>Response Alternative</u>	<u># of Respondents Per Category</u>	<u>% of Respondent Per Categor</u>
19. Do you plan to make a career of the Navy?	A. Yes	4	17
	B. Not sure	11	48
	C. No	8	35
20. Do you feel that this JPA Training Course will help you be a useful part of the Navy maintenance team?	A. Yes	19	83
	B. Not sure	3	13
	C. No	1	4

D I S T R I B U T I O N   L I S T

REPORT NO. NADC-78286-60

AIRTASK NO. A4134133/300/1413500001

	<u>No. of Copies</u>
NAVAIRSYSCOM, AIR-950D . . . . .	12
(2 for retention)	
(10 for AIR-413)	
DDC . . . . .	12

