

LEVEL <sup>H</sup>

DA072490



NORFOLK NAVAL SHIPYARD  
PORTSMOUTH, VIRGINIA  
DESIGN DIVISION

DDC  
RECEIVED  
AUG 9 1979  
RESOLVED  
A

DDC FILE COPY

JUL 13 1979  
Naval Sea Systems Command  
Affairs-00D2  
Approved for public release.  
Distribution Statement A  
*AC Barrett* # 79-642 *[Signature]*

DISTRIBUTION STATEMENT  
Approved for public release  
Distribution Unlimited

## **DISCLAIMER NOTICE**

**THIS DOCUMENT IS BEST QUALITY  
PRACTICABLE. THE COPY FURNISHED  
TO DDC CONTAINED A SIGNIFICANT  
NUMBER OF PAGES WHICH DO NOT  
REPRODUCE LEGIBLY.**

JUL 13 1979

Naval Sea Systems Command  
Public Affairs-00D2  
Approved for public release.  
Distribution Statement A

5248

*R.C. Bassett* # 49-642

⑥

WILDCAT HANDBOOK

BY

⑩

BERNHARDT KURT / STEWING  
\*  
EMANUEL JOSEPH / CLEMENTE

⑪

⑫

48 p.

DISTRIBUTION STATEMENT A  
Approved for public release;  
Distribution Unlimited

258650

79 08 - 09 038

*B*

ABSTRACT

### PREFACE

|                      |             |
|----------------------|-------------|
| ACQUISITION          | ↓           |
| NITS                 | GA. AI      |
| DPC TAB              | Unannounced |
| Justification        |             |
| By                   |             |
| Distribution         |             |
| Availability Codes   |             |
| Avail and/or special | 23P         |
| Dist                 | A           |

It seems that the Norfolk Navy Yard has earned for itself a reputation for building Wildcats. Much of the credit for this reputation is due the Pattern Shop; for until the present STANDARD PLAN DIMENSIONS FOR WILDCATS, (C & R No. 242718) was developed in 1936 by Mr. W. S. Dawley, the actual shape and dimensions of the whelps were left to the discretion of the Pattern Maker.

In developing the present standard plan, Mr. Dawley has devised a graphic method of analyzing the chain motion as the links enter and leave the pocket. He has established various contact planes passing through the link and the whelp and by describing the traces of a point on the link as it passes along these planes, he has been able to definitely establish the shapes of the pocket and whelp and to furnish the Pattern Maker with accurate dimensions for making the Pattern.

This plan, C & R No. 242718, contains a table of dimensions for use by the Pattern Maker in making a pattern of a Wildcat for various sizes of Navy Standard Cast Steel and Die-Lock Stud Link Cable.

The method for developing the pocket and whelps as set forth on this drawing, may be used to develop the pocket and whelps for other sizes of chain. However; it would be difficult for any one to trace the various steps involved in the layout from this drawing unless he were familiar with the method used in making the layout.

This handbook has been prepared primarily as a guide to understanding the standard plan, but it is possible to make the complete layout from the information contained in this book without referring to the standard plan.

An attempt has been made to separate and analyze the various steps as they occur in the layout, and to include simplified illustrations and to formulate a few rules to aid one in the making of a similar layout.

ABSTRACT

\* 1947 NO. CHANGED TO BU. NO 52601-860304 '0"

ABSTRACT  
↓

The Wildcat as we know it today, has been developing from the early years of the nineteenth century, when with the increased size of vessels it became necessary to use heavier anchors, and chain began to replace rope hawsers.

At first, the chain was hauled in by rope messengers and then attempts were made to haul in the chain by wrapping it around the capstain in the same manner as rope. This led to the design of capstains with grips to accommodate chain links.

The early attempts to construct chain capstains were so unreliable and unsafe that they began to be called "Wildcats".

The designers of these early Wildcats were faced with the baffling problem of irregularities of chain link sizes and it was not until chain manufacturers were able to produce chains to accurate dimensions and having links of uniform lengths that a scientific approach could be made to the design of Wildcats.

Some of the early Wildcats resembled a wheel having a scalloped perimeter. The scallops were concave and provided a hollow pocket to engage the links. A fairlead was located on either side of the Wildcat and slightly aft of it. The chain was led around the aft sides of the fairleads and thus held taut against the forward face of the Wildcat.

Other early designs consisted of drums with spikes that engaged alternate links.

The present American type of Wildcat seems to have been developed from an early American patent. This Wildcat had pointed whelps that engaged the flat links and had a hollow space for the vertical links.

## TYPES OF WILDCATS

There are three types of Wildcats in general use, and they may be distinguished by the names; AMERICAN, ENGLISH and EUROPEAN. There seems to be much confusion as to the application of these names to any specific type of Wildcat and they are used more or less vaguely. However; these names will serve as well as any for the purpose of distinguishing among the three general types.

1. AMERICAN TYPE (see page 5)

The American type of wildcat may be distinguished by its pointed arch type of whelp and its flat pocket bottoms.

The Wildcat described in this book is of this type.

2. ENGLISH TYPE (see page 6)

The English type of Wildcat may be distinguished by its pointed whelps with straight sides and the pocket bottoms are curved outward along a radius about the center of the Wildcat.

3. EUROPEAN TYPE (see page 7)

The European type of Wildcat is distinguished by its concave pockets which are formed by an approximate radius from a point outside the Wildcat. The whelps are formed by the intersections of the five arcs describing the pockets.

Although specific Wildcats of the "English" and "European" types have been reported by the ships to have given satisfactory service, so many Wildcats of these types have been complete failures as to lead the authors to the conclusion that they are of a faulty basic design.

The "European" type may have evolved from the chain wheel, and there is a similarity in the shapes of their link pockets. However; the chain wheel is designed for close link chain in which the links are much shorter and it contains a greater number of pockets which decreases the angle which the links assume as they enter or leave the pockets.

Unless the flat links are provided with a flat surface on which to lie, there is no positive way of determining the position they will assume in the pockets and so, although it might be possible to develop a Wildcat to the correct pitch, there can be no assurance that the chain will operate along this pitch.

The pointed arch type of whelp permits a progressive clearance between the face of the whelp and contact point on the link. It is not possible to obtain a progressive clearance between the link and whelp face in either the English or European type of Wildcat, and so, frequently the links strike the tips of the whelps.

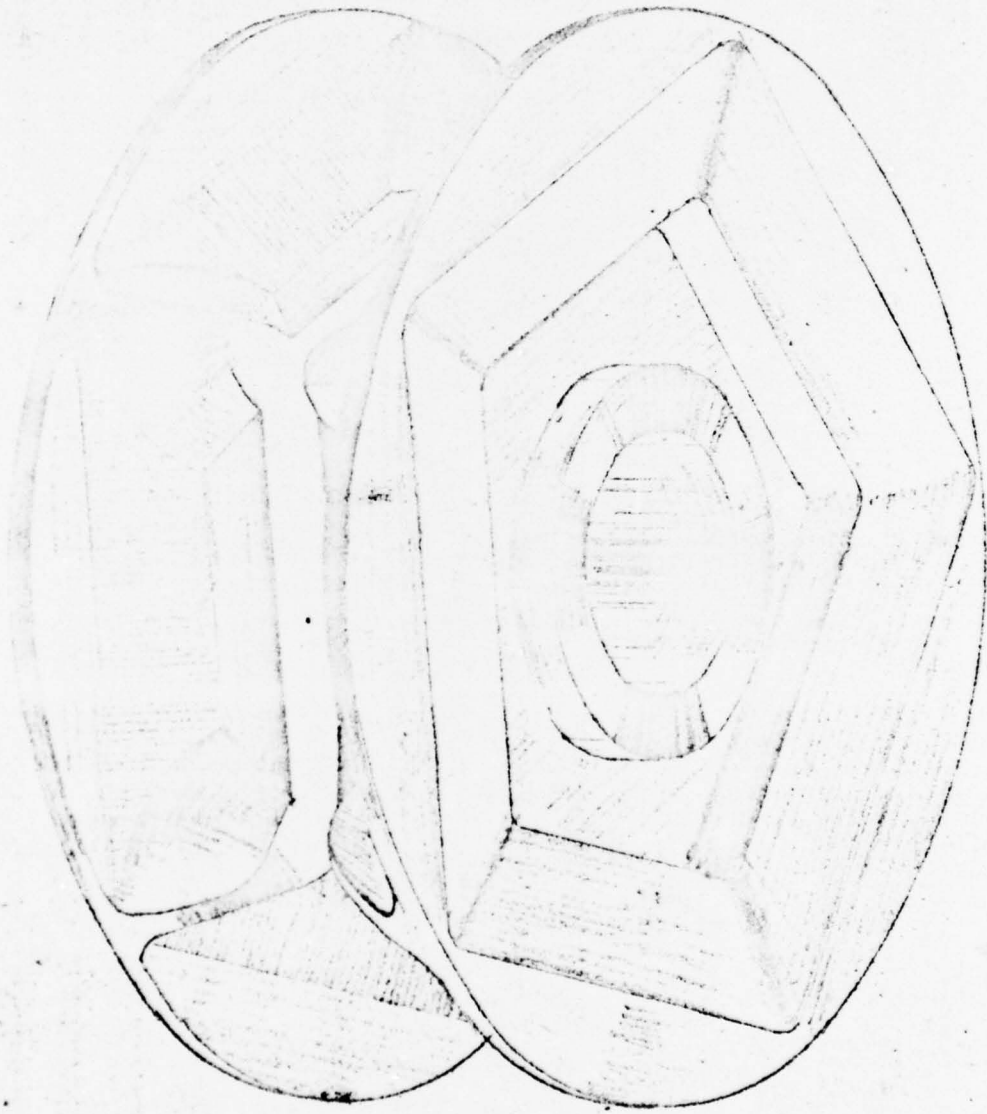

AMERICAN TYPE WILDCAT

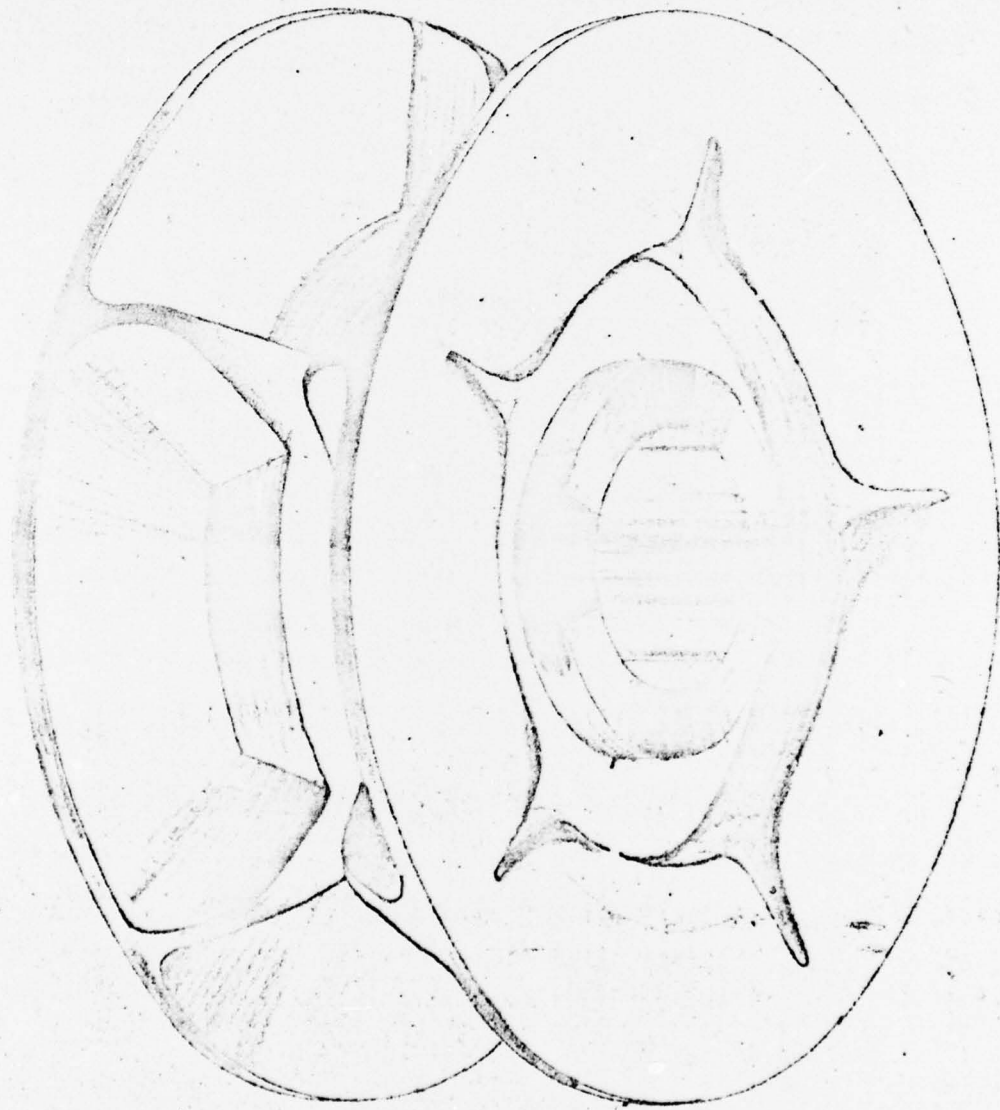

ENGLISH TYPE WILDCAT

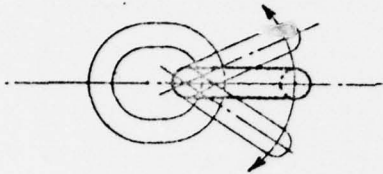

FIGURE 1

A FLAT LINK MOVES ABOUT THE CENTER OF ITS OWN END SECTION.

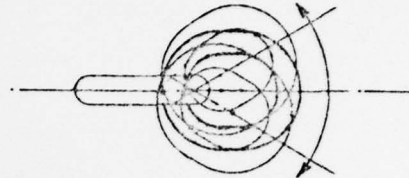

FIGURE 2

A VERTICAL LINK MOVES ABOUT THE CENTER OF THE END SECTION OF THE FLAT LINK PASSING THRU IT.

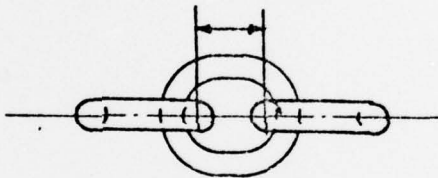

FIGURE 3

A VERTICAL LINK MAY BE CONSIDERED AS CONNECTING THE TWO FLAT LINKS THAT PASS THRU IT, AND THEREBY ESTABLISHING THE DISTANCE BETWEEN THE RESPECTIVE END SECTIONS OF THE FLAT LINKS.

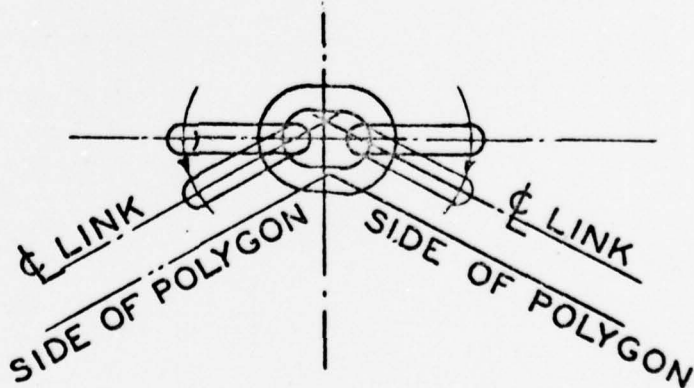

FIGURE 4

## CHAIN MOTION

Before attempting to lay out the Wildcat, it is necessary to consider the chain and chain motion upon which the design of the Wildcat is based.

Although the consecutive links in a chain are identical, it will be necessary to designate between links that are to lie flat in the chain pocket and the links that connect the flat links. As the connecting links are assumed to be in a vertical plane on the layout, they may be designated by the term "Vertical".

Thus the terms "Vertical Link" and "Flat Link" will be used throughout the explanation of the layout.

These terms are applied in the same relation even though the shaft of the Wildcat may be vertical, in which case the "Vertical Links" would actually be operating in a horizontal position.

The chain is always considered to be under tension and each link equal in length to any other link.

Each link may be considered as movable about the end section of the flat links and in a vertical plane passing through the longitudinal axis of the vertical links, see figures 1, 2 and 3.

## CHAIN WRAPPED AROUND A REGULAR POLYGON

The next step is to consider the chain wrapped around some object of uniform shape, such as a regular polygon or a circle.

Establish a vertical centerline and locate a vertical link on it. (Fig. 4)

Consider this link to be located at the apex of any regular polygon.

Lay in the adjacent flat links and then rotate them until they are parallel with the upper two sides of the polygon.

Extend the centerlines of the end sections of the flat links. They will intersect on the vertical centerline of the polygon.

The longitudinal centers of the flat links will occur on the centers of the sides of the polygon, and therefore determine the length of the sides of the polygon about which the chain can be wrapped. (See Fig. 5)

If the flat links were to be made to lie on the sides of a polygon such as described above, some provision would have to be made to permit the vertical links to drop below the sides. So a circular groove is provided for this purpose.

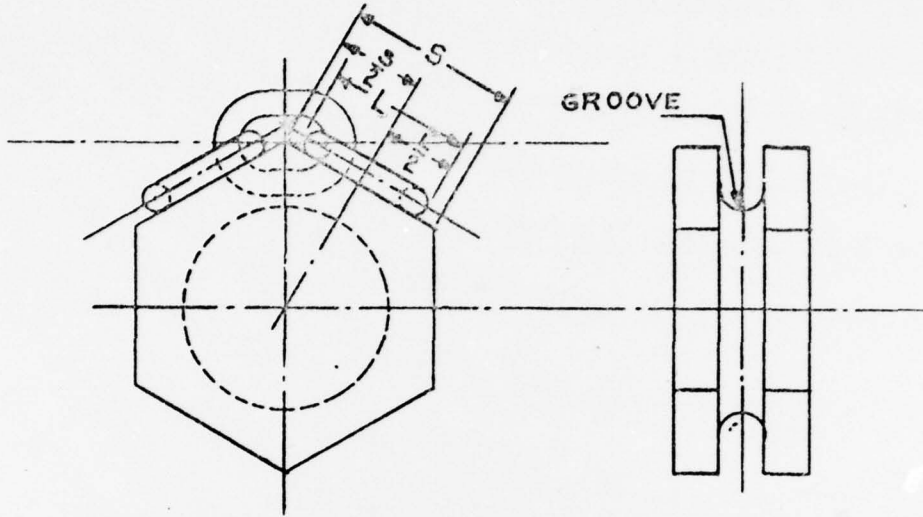

FIGURE 5

THE LENGTH OF THE LINK DETERMINES THE LENGTH OF THE POLYGON SIDE.

SEE PAGE 9

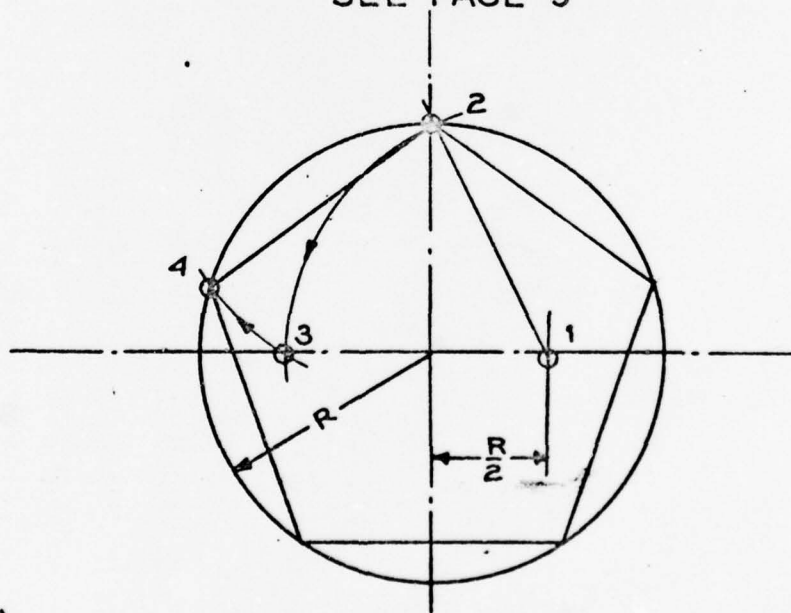

FIGURE 6

A PENTAGON INSCRIBED IN A CIRCLE  
SEE PAGE 11

### WHY THE PENTAGON

Wildcats could be developed about virtually any regular polygon, but the greater the number of sides, the larger the Wildcat would have to be. A large Wildcat would not only require more material, but the effective turning radius would be great and would require more effort from the turning machinery.

The pentagon provides the smallest practical shape about which the chain can be wrapped and unwrapped under tension.

### LAYING OUT THE WILDCAT

In the actual layout and development of the Wildcat there are various allowances and corrections that must be included, but they are not presented in the first few explanatory steps. They will be presented as they occur and affect the layout.

### THE PENTAGON

The first step is to lay off a pentagon.

The size of this pentagon will have no direct bearing on the remainder of the layout, and is used only to establish the shape. This pentagon should be fairly large and its actual size is a matter of judgement. If the pentagon is to be inscribed in a circle, a radius equal to the length of the link plus one diameter may be used.

(See Fig. 6)

Draw a circle and construct the vertical and horizontal centerlines. To the right of the vertical centerline locate point No. 1, ( $\frac{1}{2}$  radius from vertical centerline). With point No. 1 as a center, describe an arc having a radius equal to the distance from point No. 1 to point No. 2 (intersection of vertical centerline and circumference) and intersecting the horizontal centerline at point No. 3.

The distance from point No. 2 to point No. 3 will be equal to the length of one side of the pentagon and can be marked off on the circumference at point No. 4.

The other four sides may then be marked off on the circumference and any inaccuracy may be corrected.

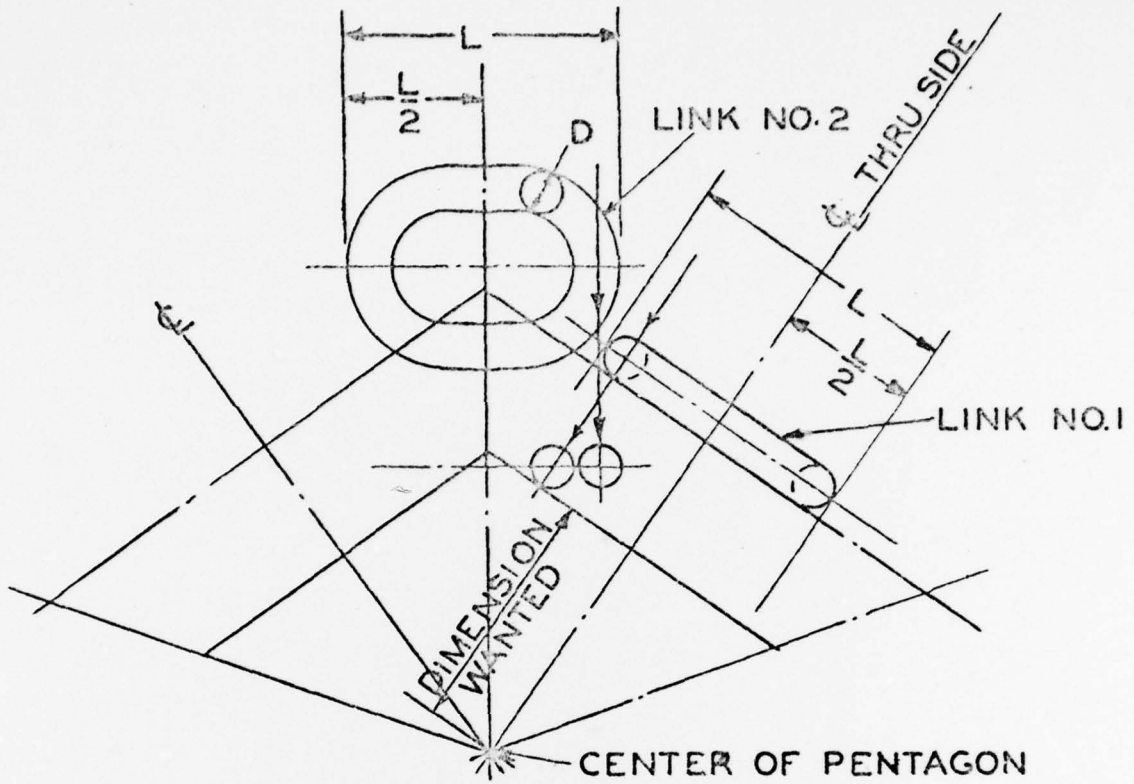

FIGURE 7

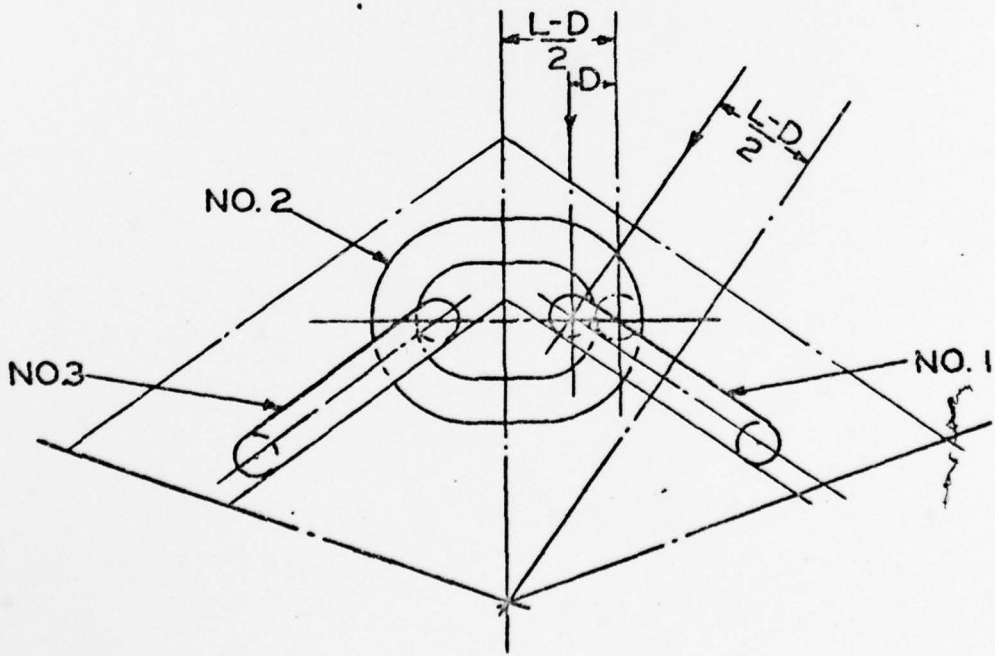

FIGURE 8

Establish the centerlines through the sides of the pentagon and passing through the center of the pentagon. (See Fig. 7)

The exact pentagon about which a certain size chain will wrap must be established.

To do this, two links must be projected together along their respective vertical centerlines.

Refer to Figures 7 & 8

A. - Consider the centerline through the side of the pentagon as also being the centerline of the flat link to the right of the apex. This link will be considered as link No. 1 throughout the explanation of the layout.

B. - Consider the vertical centerline of the pentagon as also being the vertical centerline of the vertical link. This link will be considered as link No. 2 throughout the explanation of the layout.

The link to the left of the apex will be considered as link No. 3.

The overall length of the link will be indicated as "L".

The wire diameter will be indicated as "D".

C. - Locate a point to the right of the vertical centerline by a distance equal to  $(\frac{1}{2} L - 1 \frac{1}{2} D)$ , Fig. 8.

Project a vertical line through this point.

The centerline through the upper right hand side of the pentagon has been established. Locate a point to the left of the centerline by a distance equal to  $\frac{L - D}{2}$ .

Project a line through this point parallel to the centerline of the pentagon side.

These two lines will intersect at a point which locates the center of the left hand end section of link No. 1.

This establishes the pentagon about which the chain would wrap if there were no clearance or tolerances to be allowed.

14

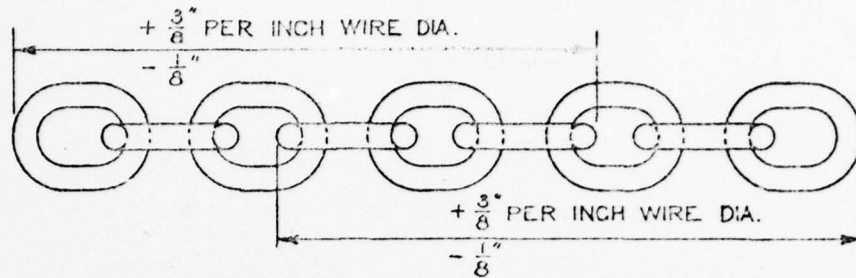

FIG. 9

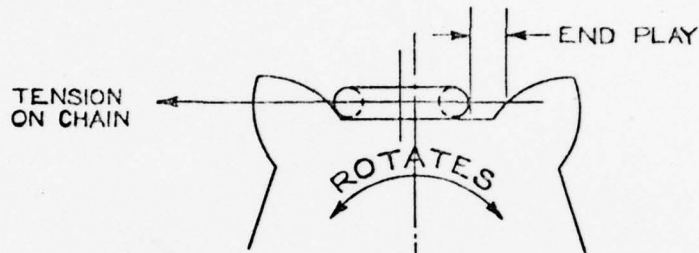
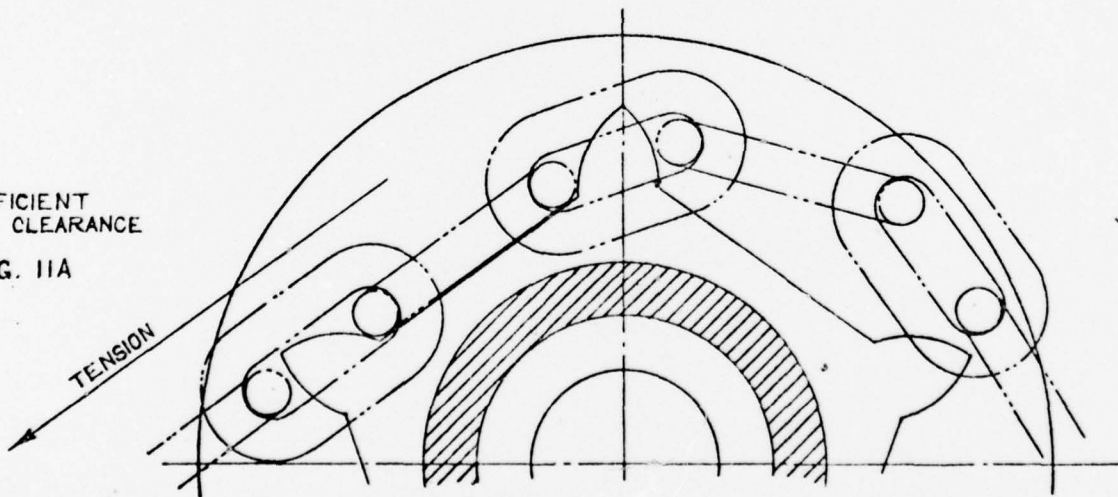

FIG. 10

THE WEIGHT OF THE ANCHOR CREATES A TENSION ON THE CHAIN WHICH CAUSES THE LINKS TO BEAR ON THE AFT FACE OF THE WHELPS REGARDLESS OF THE DIRECTION OF ROTATION OF THE WILDCAT.

INSUFFICIENT  
MINUS CLEARANCE

FIG. 11A



INSUFFICIENT  
END PLAY

FIG. 11B

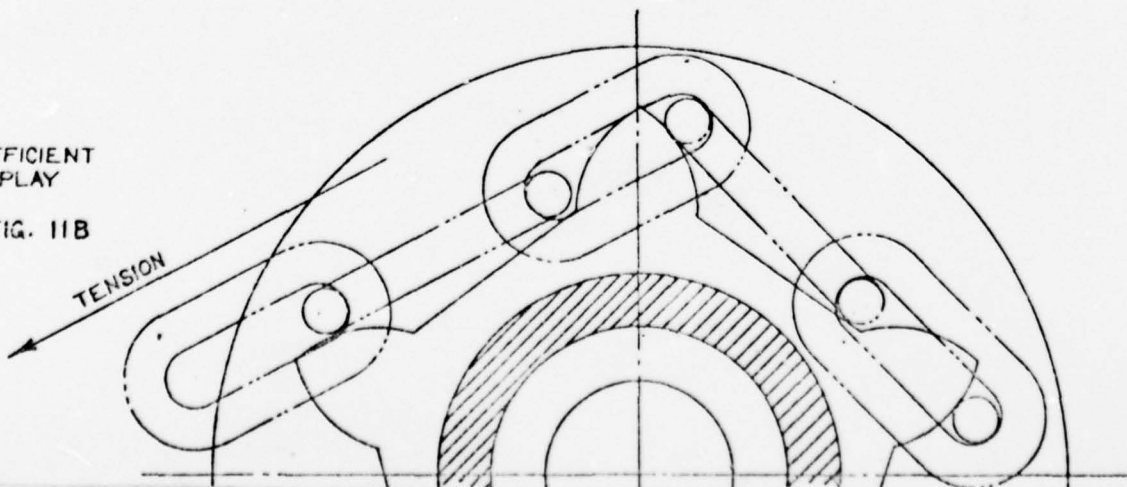

### CHAIN TOLERANCES

The actual chain varies in length of sections due to small variations in the lengths of the links.

The permissible tolerances for die-lock stud link chain is as follows: (See Standard Plan for Stud Link Chain Cable - Die Lock type - Bu. No. 205393).

A minus tolerance of  $1/8"$  or a plus tolerance of  $3/8"$ , per inch of wire diameter in the length of six links. This tolerance to be checked every third link. (See Fig. 9).

Thus the total tolerance, either plus or minus, may occur within the range of three links. For example, it would be possible to measure the overall length of a piece of chain having six links, and find its length to be within the specified tolerance either plus or minus. But an accurate check of the dimensions of each link might disclose that the first three links were short by the total minus tolerance permissible for six links and the remaining three links might be long by the total plus tolerance for six links.

For plus tolerance, an end clearance must be provided to permit free exit of the chain from the pocket. This clearance is called "END PLAY" and it is the distance between the non-bearing end of the link and the nonbearing face of the whelp when the other end of the link is bearing on the face of the whelp at the other end of the pocket. (See Fig. 10.)

For minus tolerance, the distance between consecutive bearing faces of the whelps must be shortened.

Fig. 11-A illustrates a Wildcat having insufficient minus tolerance. Consider a link bearing on the face of a whelp at A. As the Wildcat rotates, the next flat link must seat itself at B, the contact point on the consecutive whelp. If the distance between the faces of the whelps is too great, the link will be forced to contact the face of its whelp too high. The following flat link will be forced to take a still higher point on its whelp, and so each consecutive link would be forced to contact its whelp at a higher point until one of the links slipped over the tip of a whelp.

The chain always bears on the aft side of the whelp, both when being hauled in and when being walked out. This fact is very evident on an old Wildcat where the worn face of the whelp is easily compared with the unused face. This is, of course, due to the weight of the anchor creating a tension on the chain and when the anchor is being walked out, the Wildcat acts as a brake. Thus, unless the anchor gear is rigged so that the load creates a tension on the chain in the opposite direction, only one face of the whelp will wear and frequently it is possible to exchange the starboard and port Wildcats when the whelps are badly worn on only one face.

### NIBUS TOLERANCE

Probably the most important factor in the design of a satisfactory Wildcat is the attention given to the NIBUS TOLERANCE IN THE PITCH OF THE WHELPS. The pitch must be established to provide ample clearance for the "short" links, for when the distance between the contact points on consecutive whelps is too great to permit the shortest links to move freely along the face of the whelp, the links will "ride high" and eventually slip.

In the operation of a Wildcat, a tight chain becomes more apparent when the chain is being "walked" out. Frequently, this item is overlooked and the chain must be permitted to "run" out and thus chance the possibility of the anchor striking the lower portion of the ship's hull.

When the chain is permitted to "run" out, the Wildcat exerts little restraining force on the links and so they are able to seat themselves in the chain pockets between the whelps. However; in some cases the chain has been known to rise up out of the pockets when being "run" out over a Wildcat of extremely large pitch for that particular chain.

The hauling in operation seldom gives trouble due to the tremendous load on the chain tending to force the links into the pocket, however, if the pitch of the whelps is too great for the chain, the links will have a tendency to stick in the pockets and it becomes necessary to use a chain stripper to free them.

When the pitch of the Wildcat is too small for the chain, or the end-play is insufficient to permit the links to lie flat in the pocket, the chain has a tendency to slip on the hauling in operation.

In this case, the links tend to "ride" too high on the whelps due to the whelps being too close together. See Fig. 11b, Page 14.

### WHELPS

The illustrations so far, have indicated the chain as being cut along its vertical centerline. But it would be impossible to make a contact on the flat links along this plane as the vertical links occupy the space at the end of the flat links. Therefore; in order to establish a bearing on the flat links, lugs or whelps projecting from the sides of the chain pockets must be used. These whelps are similar to the teeth on a gear or sprocket.

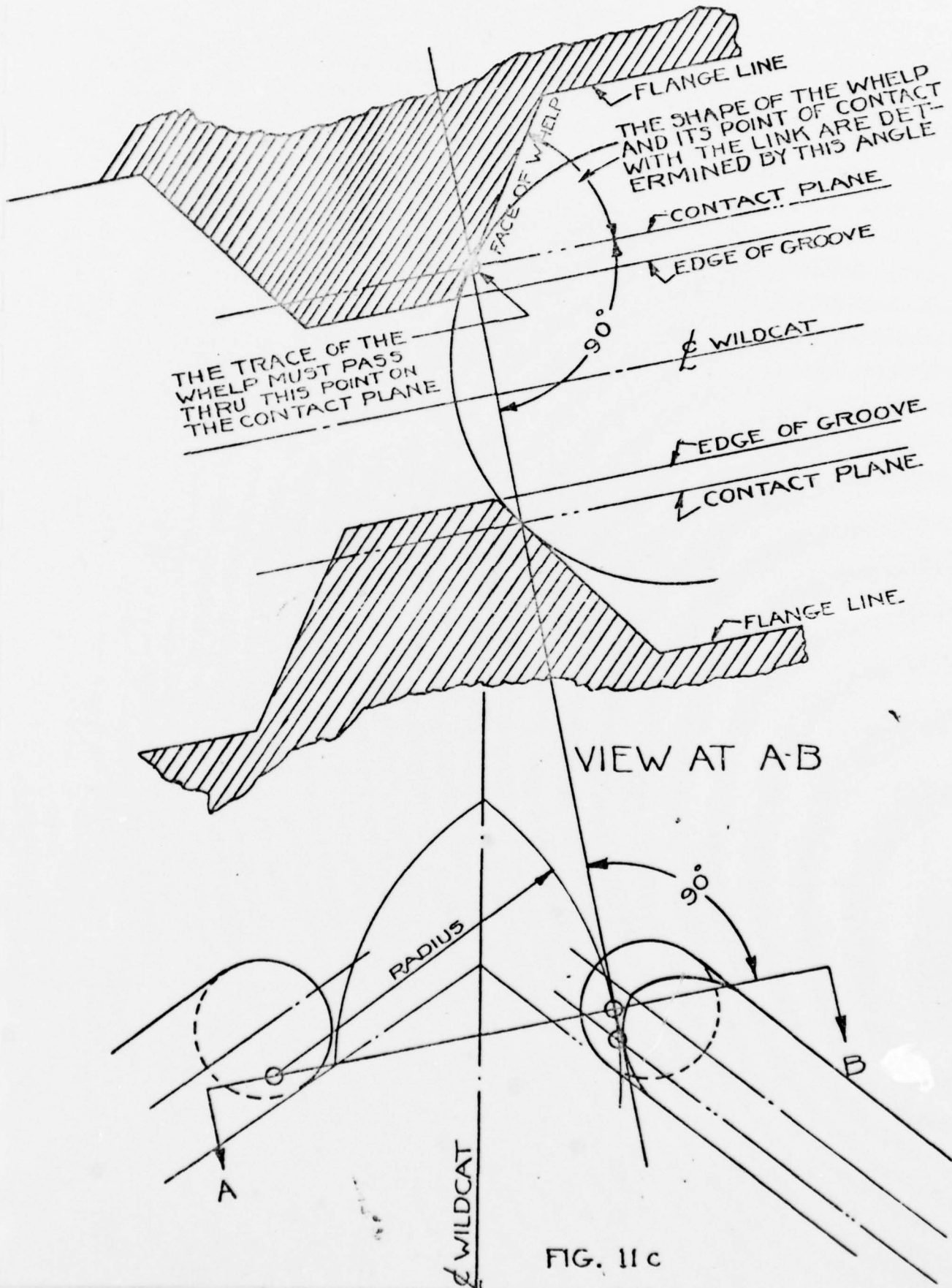

FIG. II c

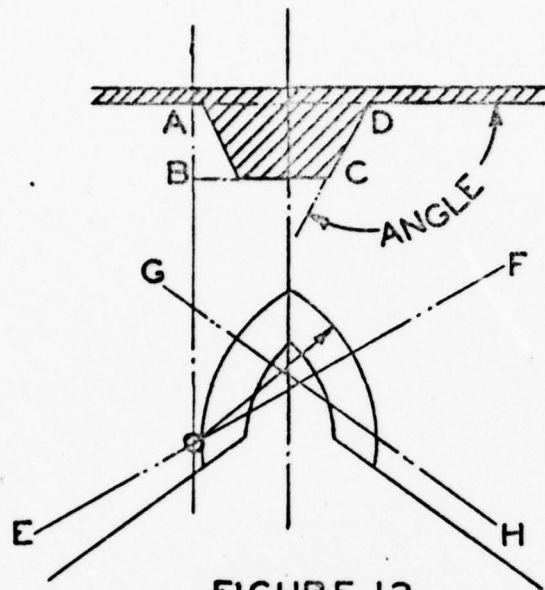

FIGURE 12  
 PLANE A-B-C-D IS REVOLVED  
 ABOUT CENTERLINE A-B  
 E-F, SEE FIGURE 13-A  
 G-H, SEE FIGURE 13-B

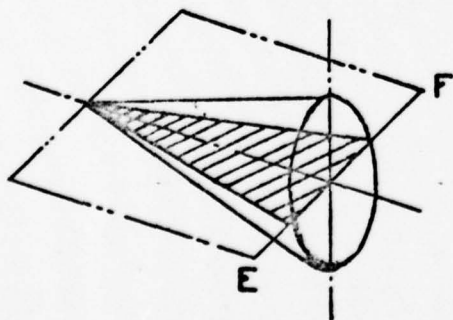

FIGURE 13-A

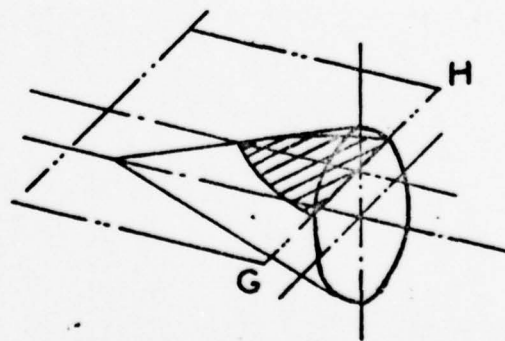

FIGURE 13-B

REFER TO FIG. 12 LINE E-F  
 PLANE PASSING THRU THE  
 CENTERLINE OF A CONE  
 INTERSECTS THE FACE OF THE  
 CONE ALONG STRAIGHT LINES.

REFER TO FIG. 12 LINE G-H  
 A PLANE PASSING THRU A  
 CONE WITHOUT PASSING THRU  
 THE CENTERLINE OF THE CONE  
 INTERSECTS ITS FACE ALONG  
 CURVED LINES.

It must be remembered that only the flat links bear on the whelps, the vertical links serve only to connect the flat links, and pass between the whelps. Theoretically, the vertical links never touch the Wildcat; they pass between the whelps and there is a groove provided at the bottom of the pocket with ample clearance to prevent the vertical links from striking the Wildcat.

The shape of the whelp is determined by the angle of its face and a radius establishing the trace of a plane known as the contact plane. The face of the whelp is actually a portion of a cone and a plane passing through the radius point and the face of the whelp, cuts the face along a straight line. (Fig. 13-A). But if this plane did not pass through the radius point, it would intersect the face of the whelp along a curved line, (Fig. 13-B).

The flat link that bears against the whelp is not parallel to a plane passing through the radius point of the whelp when the link is in the chain pocket. And so it must contact the whelp at a point along a curved line. Thus the point of contact between the link and the whelp is the point of tangency of the curved trace along the face of the whelp and the trace of the same plane passed through the link. (Fig. 21, Page 33)

The point of tangency can be assumed on the link and the angle of the whelp face made so as to contact the link at this point.

If the point of tangency on the link occurs too far from the end of the link, the link will have a tendency to wedge itself between the whelps, and if the point occurs too near the end of the link, the link will bear on the edge of the whelp. The point of tangency should occur on the link at about 41 degrees from the end.

Since the link is to contact the whelp along a curved line, the angle of the whelp face will not be the exact complement of the angle of the point of contact on the link. The curve tends to move the point of contact on the link farther from the end.

Thus, if the face of the whelp is at an angle of  $54 \frac{1}{2}$  degrees, the point of contact on the link will not occur at exactly  $35 \frac{1}{2}$  degrees from the end, but will be more nearly at 41 degrees.

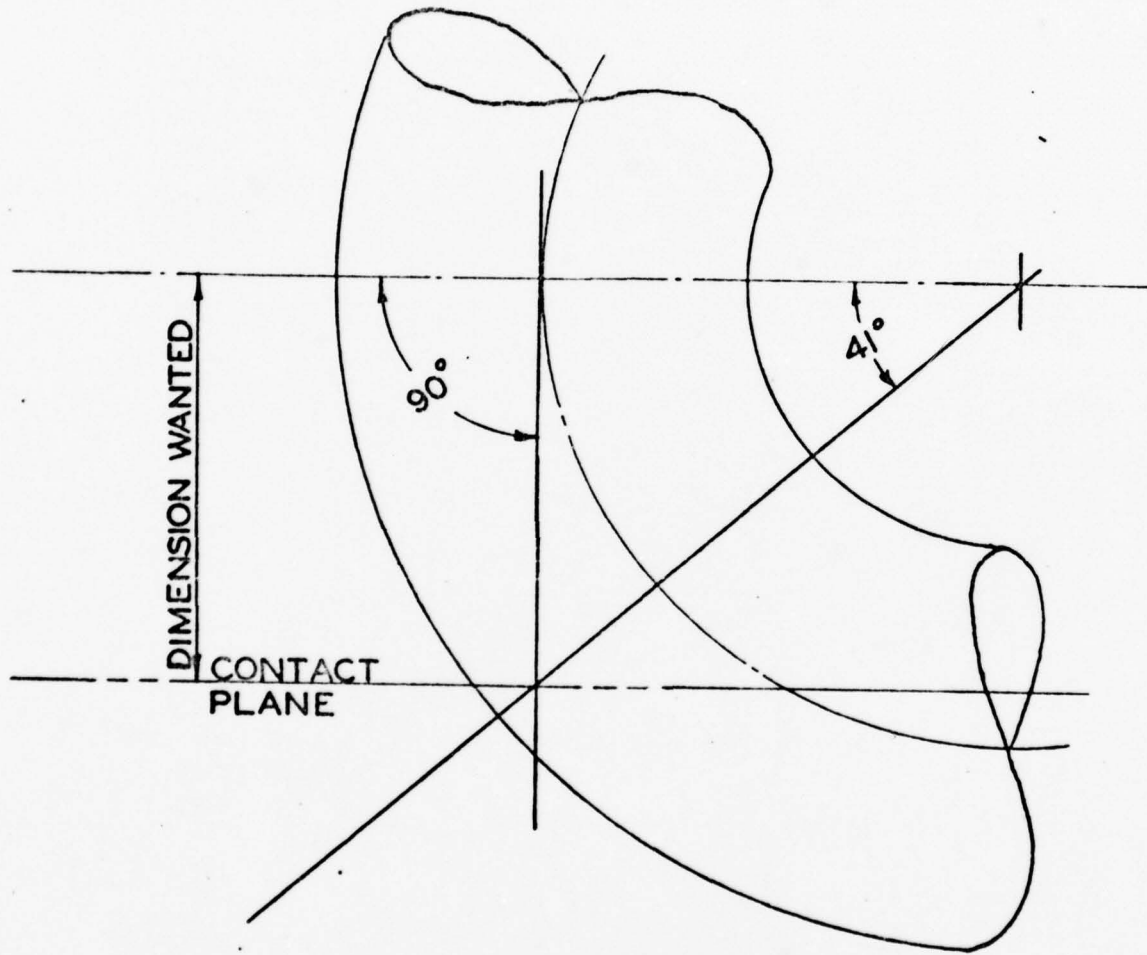

FIGURE 14

The radius governing the shape of the whelp is determined by the length of the links and approximates the path of a point on one link as it enters or leaves the chain pocket.

The layout is begun with one flat link bearing against the right hand face of the whelp at the apex of the pentagon, and the pitch of the Wildcat is made such that the next flat link will also bear on its whelp.

Since the amount of end-play allowed determines the location of the link when it bears against the whelp, it is an important item in determining the pitch of the whelps.

Thus, the pitch of the whelps is governed by two factors; the length of the links and the amount of end-play.

**LOCATING THE CONTACT PLANE**

The contact plane is a plane passed through the point of contact of the link and the whelp. There are two such planes, one being a vertical plane and the other being a horizontal plane parallel to the longitudinal centerline of the flat link. (See Fig. 17, Page 27.).

Unless specifically designated otherwise, the term "CONTACT PLANE" refers to the vertical contact plane.

A true contact plane may be located by the method shown in Fig. 14, Page 20.

Draw in the top view of the flat link. Draw a line through the radius center at the end of the link at an angle of 41 degrees to the end of the link. Locate the wire center at the end of the link. Draw a line at 90 degrees to the longitudinal centerline of the link through this point and let it intersect the 41 degree line.

This establishes the contact point and the contact plane passes through this point.

In order to have sufficient bearing strength on the whelp, the distance between the center of the groove and the contact plane may have to be arbitrarily increased.

The distance from the center of the groove to the contact plane is usually one wire diameter except for small wire dias. where it becomes necessary to increase the distance in order to have sufficient bearing material between the contact plane and the edge of the groove.

**WIDTH OF THE GROOVE AND THE FLANGE**

The width of the groove is determined by the thickness of the detachable links and kenter shackles and their widths determine the width of the flange at the bottom of the pocket.

## CORRECTING LINK FOR MINUS TOLERANCE

For the actual development of the Wildcat, a link that has been corrected for minus tolerance is used. The reason for this is, as previously explained, that the distance between consecutive whelps must be shortened to provide proper seating of the link against the whelp and prevent the link from "riding" up on the point of the whelp.

The length of the link to be used will be equal to the nominal length minus one third of the total minus tolerance permitted for six links.

NOMINAL LENGTH OF THE LINK -  $\frac{\text{TOTAL MINUS TOLERANCE}}{3}$  = L (used)

## END PLAY

The end play to be allowed is a matter of judgement and may be assumed to be twice the total plus tolerance for six links, or may be taken from Standard Plan (C & R No. 242718).

In small chain, the end play is usually equal to the wire diameter and it is usually somewhat smaller in proportion as the wire diameter increases.

In any case, it must exceed the total plus tolerance for six links since this total may occur within three consecutive links.

## CORRECTING THE SIDES OF THE PENTAGON (Fig. 15 and 16)

The sides of the pentagon must be corrected for the minus tolerance and so the corrected link is used in the layout. The layout is actually started with this corrected link, but to prevent confusion and for the purpose of simplicity of explaining the various steps, a link of nominal length was used in presenting the previous steps of the layout.

Link No. 1 must be advanced toward the apex of the pentagon by one half of the end play. It may be drawn in on the previously indicated centerline parallel to the side of the pentagon.

The next flat link, No. 3, will occur to the left of the apex. Its centerline must be parallel to the side of the pentagon, and the same distance from the center of the pentagon as the centerline of link No. 1.

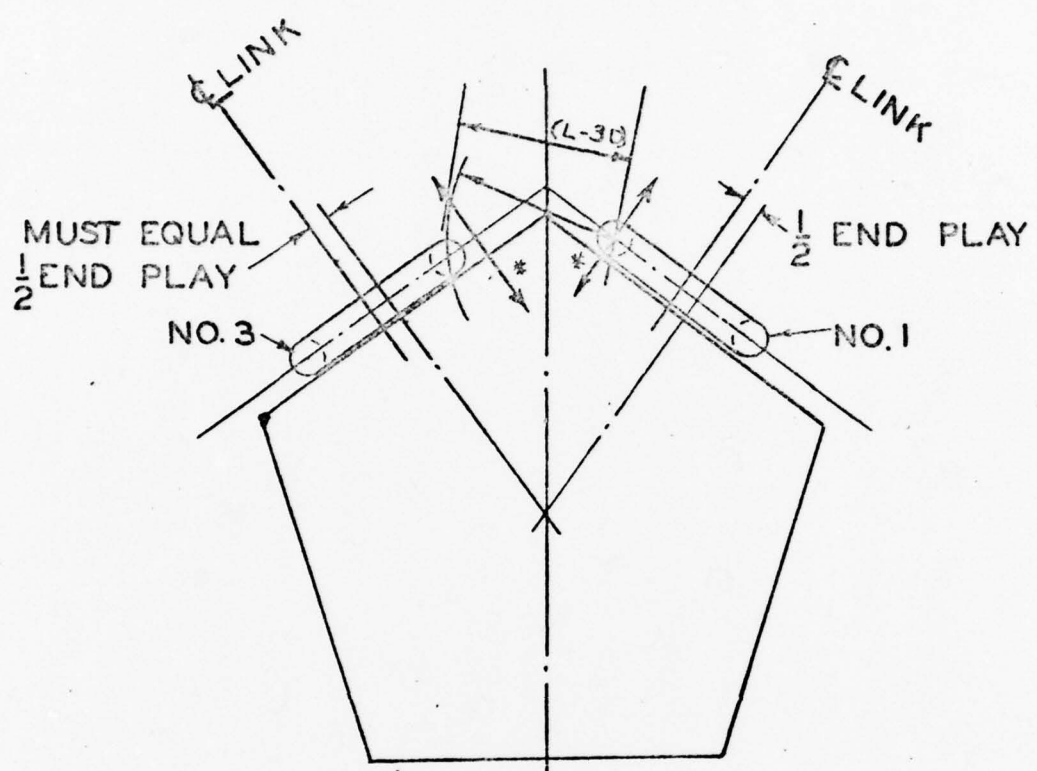

\* WHEN LINK NO.1 IS MOVED EITHER IN TOWARD THE CENTER OR OUTWARD, THE LONGITUDINAL CENTERLINE OF LINK NO.3 MUST BE MOVED INWARD OR OUTWARD BY THE SAME AMOUNT.

FIGURE 15

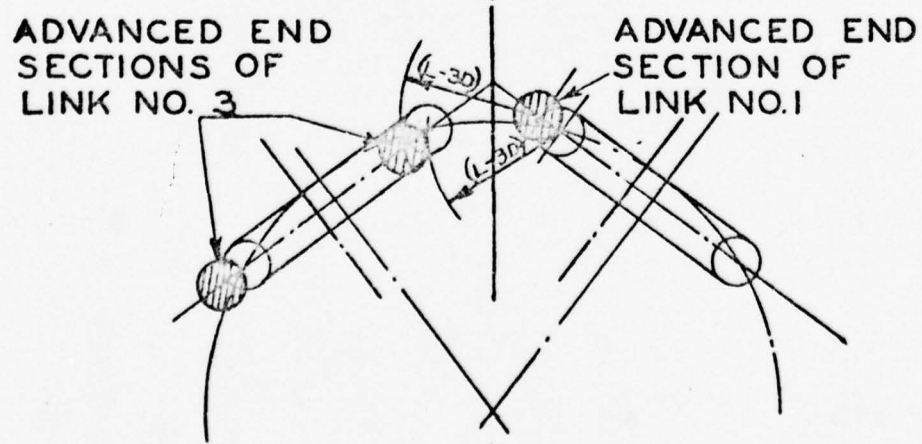

FIGURE 16

The vertical link, No. 2, between these two flat links governs their distance apart and so the centers of their end sections will be apart by a distance equal to the overall length of a link minus three diameters.

It will be seen that when link No. 1 is advanced by 1/2 the end-play, link No. 3 is not necessarily advanced by the same amount. This is due to the centerline passed through their end sections not remaining on a horizontal line.

They can be made to advance the same amount by increasing or decreasing the size of the pentagon to suit.

If link No. 3 falls short, the sides of the pentagon must be moved in toward the center. Correspondingly, if link No. 3 advances too far, the sides of the pentagon must be moved outward.

This may be done by trial and error as shown in Fig. 15, but the following formula derived by Mr. James Mahadeen may be used to obtain the exact dimensions of the pentagon corrected for end-play.

#### FORMULA FOR PENTAGON CORRECTED FOR END-PLAY

(See Fig. 16-A)

- S- Pitch of pentagon corrected for end-play
- L- Length of link corrected for minus tolerance
- D- Diameter of chain wire
- P- End-play

$$S = (L-D) + \sqrt{1.5278 (L-3D)^2 - .5278 P^2}$$

#### CHECKING THE LAYOUT FOR PLUS TOLERANCE

After establishing the pentagon corrected for minus tolerance, a check must be made to determine the end clearance in the event of "long" links occurring together.

Assume the left hand end of link No. 3 as being fixed.

Determine the plus tolerance per link and, working to the right, lay out three "long" links. The right hand end of "long" link No. 1 should not extend beyond the right hand of "short" link No. 1 by more than the total end-play.

If the actual measurements of the chain indicate a possibility of the chain being long, the end-play should be increased. However; if the chain measurements indicate that the chain is nearly to nominal length, the occurrence of occasional long links will not greatly affect the operation of the Wildcat.

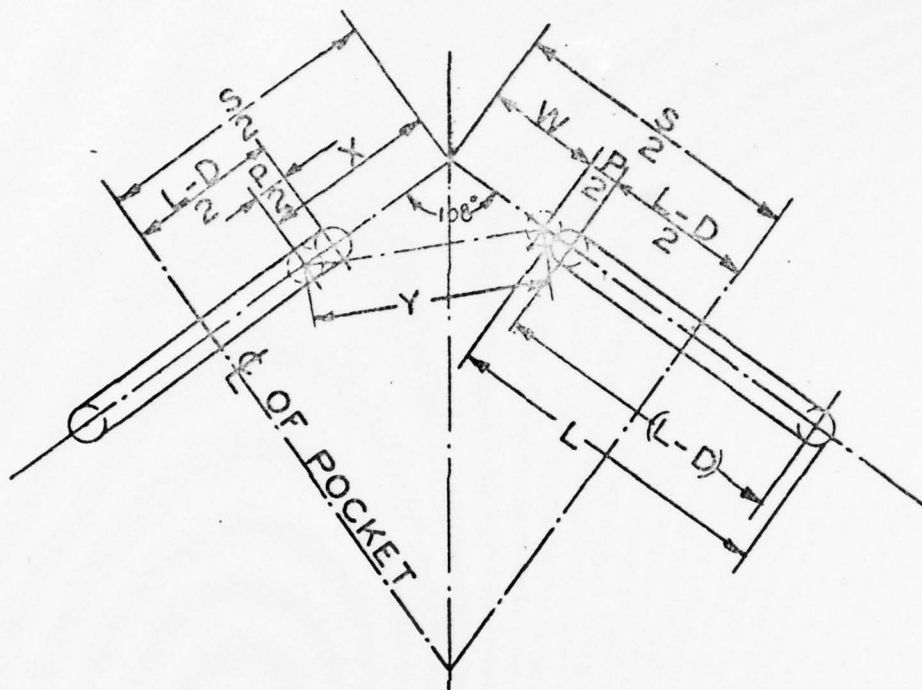

FIGURE 16A

$$S = (L - D) + \sqrt{1.5278 (L - 3D)^2 - 0.5278 P^2}$$

### CONTACT PLANE

A vertical plane may be passed through the point of contact of the link and the whelp and on this plane, the shape of the whelp may be developed.

The location of this plane must be assumed primarily by judgement. The two principal factors to be considered are:

1. The whelp must contact the link along its end section. This point of contact must occur at an angle of less than 45 degrees from the end of the link. (See page 21, Locating the Contact Plane)

2. The contact plane on the whelp must be far enough from the edge of the groove to permit ample bearing strength on the whelp.

The face of the whelp is a conical section and therefore its generating plane passes through and revolves about a center-line (See Fig. 12). A plane passing through the flat link parallel to its edge intersects the face of the whelp, but does not pass through the generating center of the whelp (See Figs. 12, 13-A & 13-B). The intersection of this plane and the face of the whelp forms a curved line. This will be seen in the layout.

If this plane passed through the link also passes through the contact point of the link and the whelp, the curve on the face of the whelp and the contact curve on the link may be developed.

These two curves must touch at the point where the contact plane intersects them.

Draw in a top view of link No. 1 projected from the link advanced by one half the end-play. (Fig. 18)

Lay in the edge of the groove, the contact plane, and the flange line.

These dimensions can be taken from the Standard Plan.

The contact plane is a vertical plane passing through the assumed point of contact of the whelp and the link.

The trace of this plane on the link must first be established and then, the trace on the whelp can be established as a curved line or segment of a circle tangent to the trace on the link.

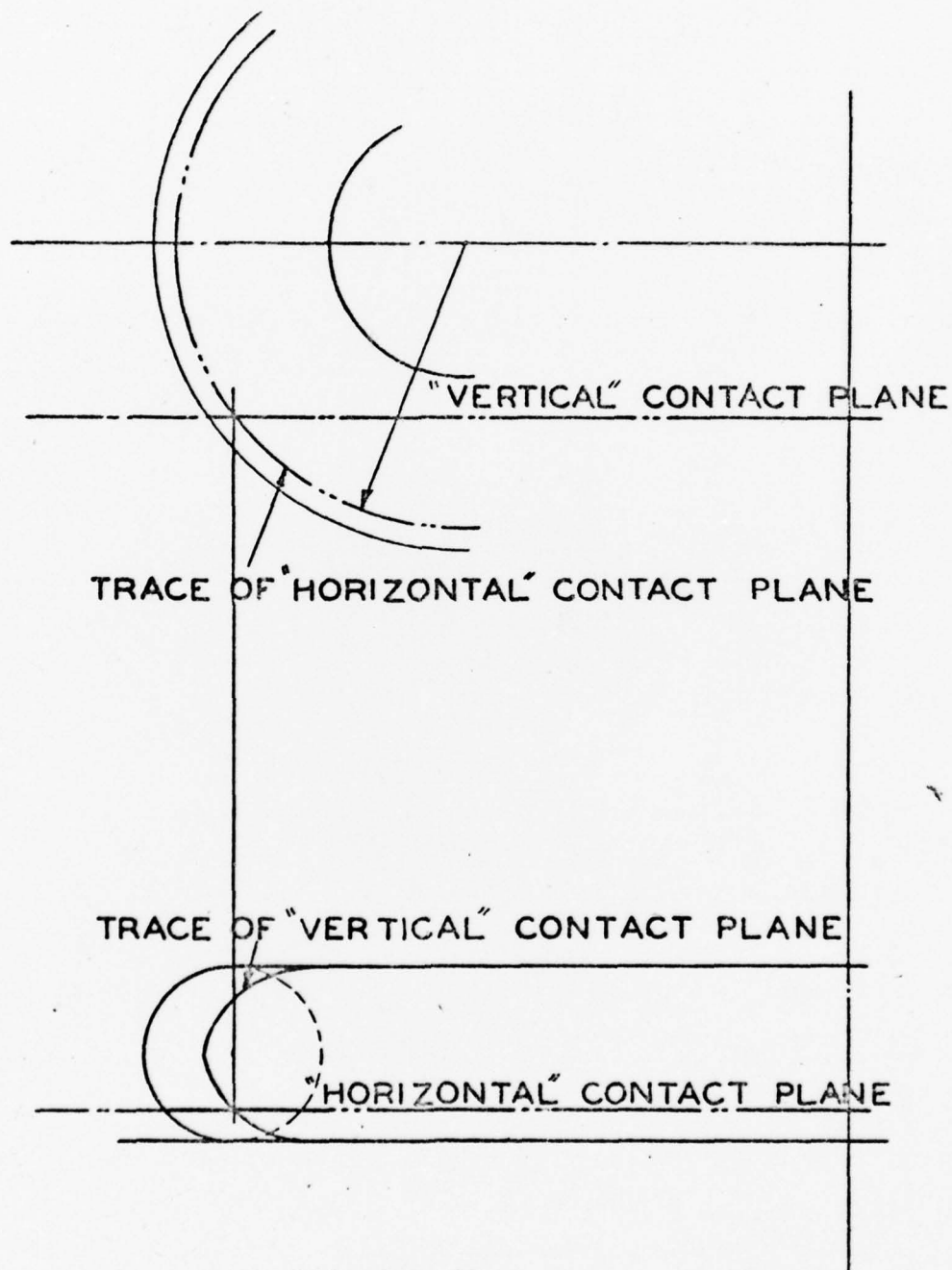

FIGURE 17

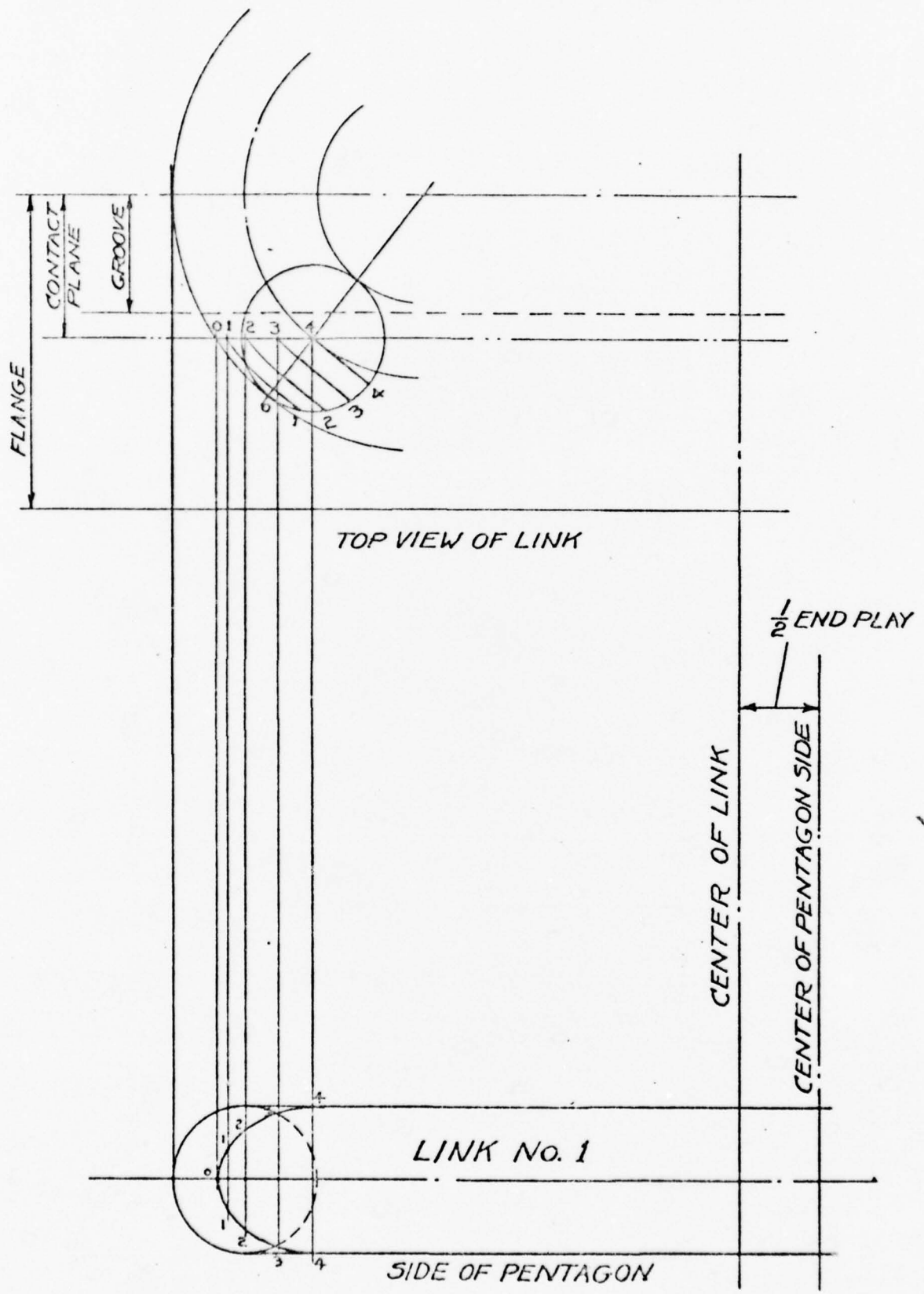

FIG. 18

In the projected view of link No. 1, draw an arc through the end of the link using the radius point of the link as a center, and describing the centerline of the wire.

This arc will intersect the contact plane.

Draw a line through this point and the center of the arc, and erect its perpendicular through this point. Draw a circle representing the cross section of the wire about this point. In the lower left hand quadrant, mark off four equal points on the circumference. Project these points parallel to the perpendicular onto the centerline of the wire section. Rotate these points about the center of the radius of the link, and establish their intersection points with the contact plane.

Project these points from the contact plane to the side view of the link. From the cross section view of the wire, the perpendicular distances of the four points can be marked off on the projected lines and the trace of the contact plane on the link developed with a french curve.

Using the right hand end section of link No. 3 as a center, describe an arc tangent to the trace of the contact plane on link No. 1. This arc describes the path of a point on the link revolving along the contact plane. This is the actual path of the link and the whelp must be made smaller to provide clearance and assure free entrance of the link into the pocket.

Using the center of the end section of link No. 1 as a point, describe an arc through the center of the end section of link No. 3. Establish a point where this arc intersects a line  $1/4$  of the wire diameter below the centerline of link No. 3. Using this point as a center, describe an arc tangent to the trace of the contact plane on the link No. 1. This arc will be the actual trace of the contact plane on the whelp.

To develop the traces of the edge of the groove and the flange line on the whelp, a projection is made along a line normal to any line passing through the center of the arc describing the contact plane on the whelp and intersecting this arc.

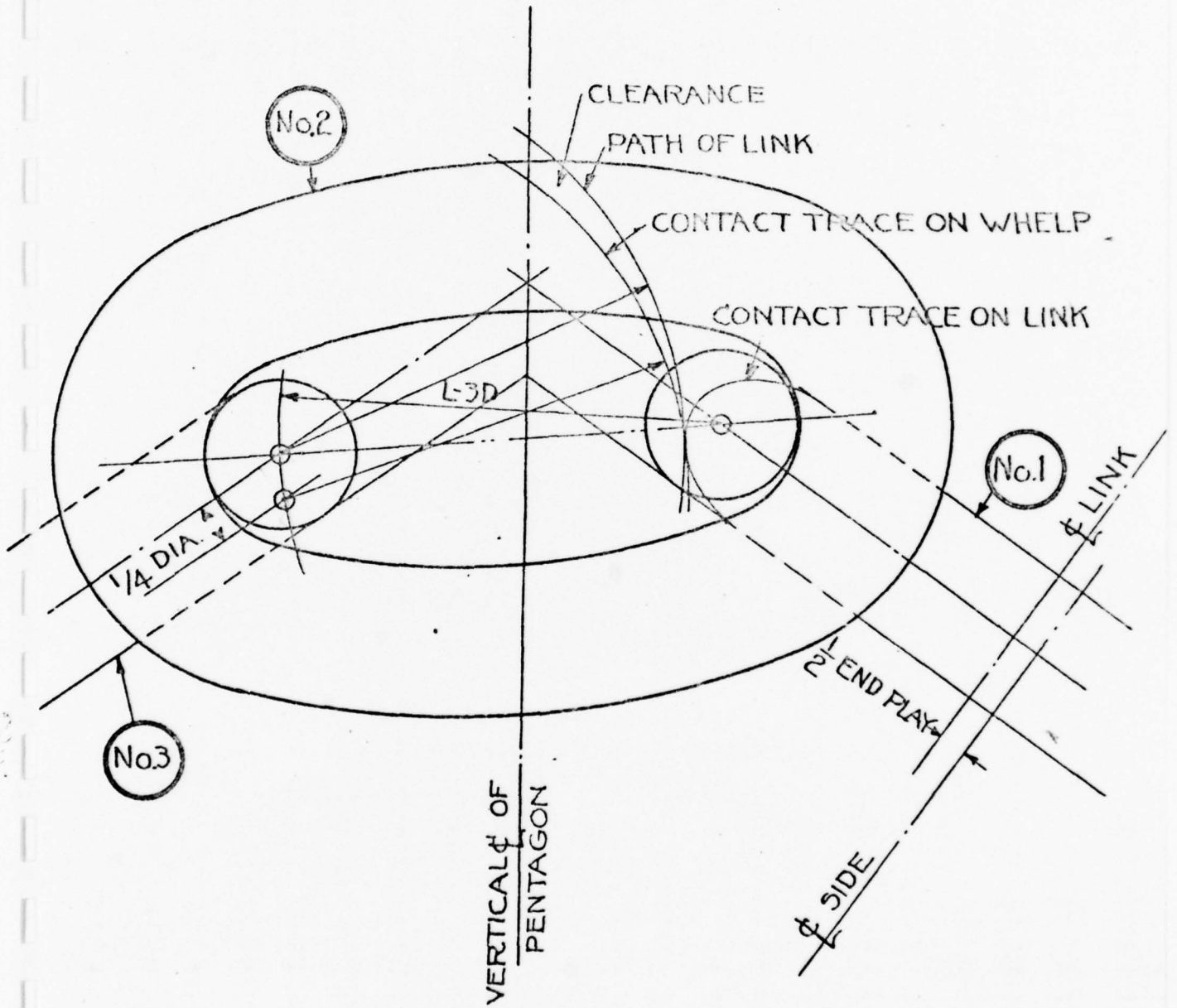

FIGURE 19

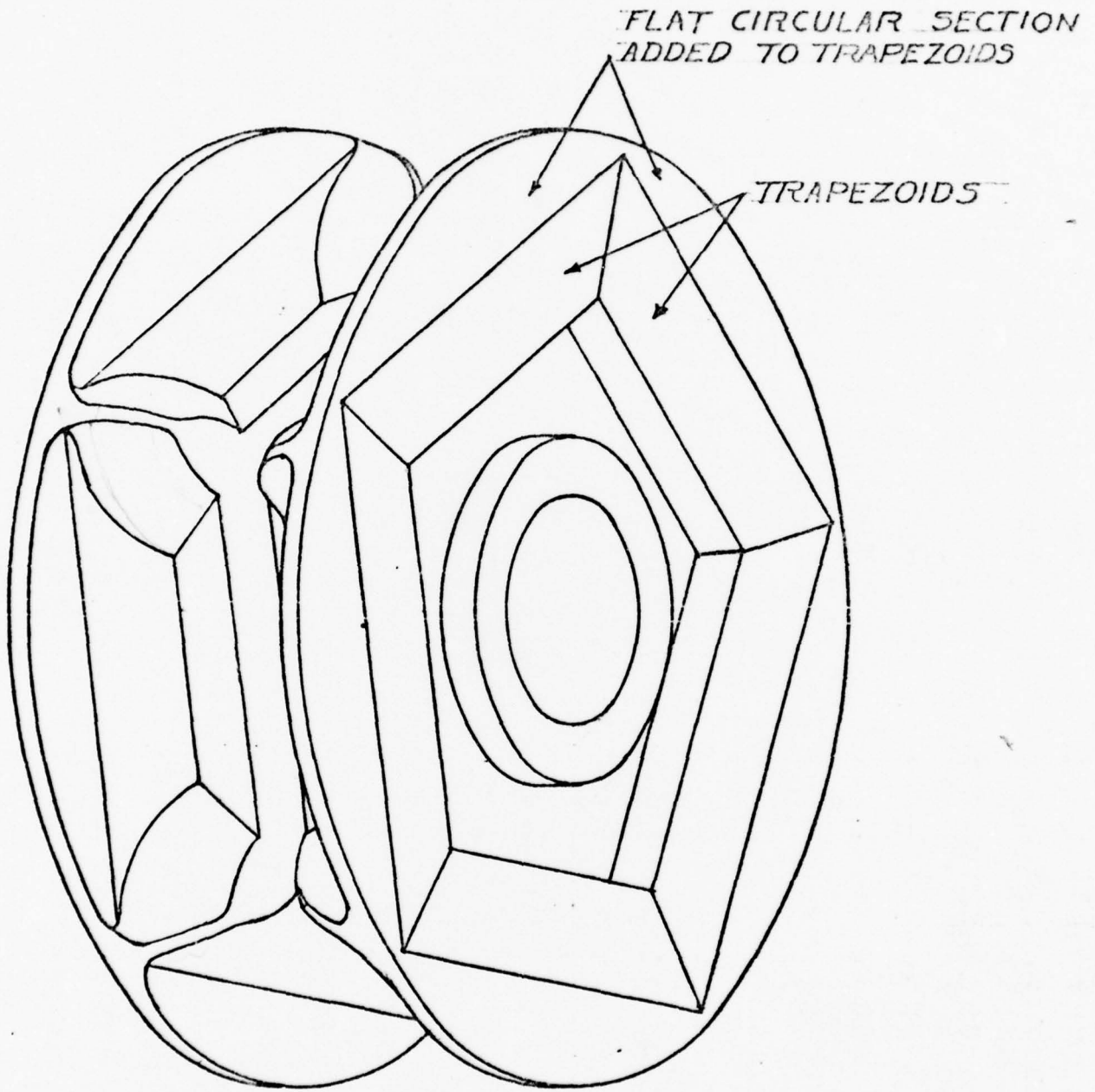

FIG. 20.

3

Draw a line through the center of the arc describing the contact plane on the whelp and intersecting the arc. Erect a perpendicular to this line at the point of intersection. Establish a normal to this perpendicular and let it represent the contact plane in this view. Through this point of intersection, draw a line at an angle of  $35\frac{1}{2}$  degrees to the perpendicular in the upper right hand quadrant. Locate the flange line above the contact plane and the edge of the groove below the contact plane. The  $35\frac{1}{2}$  degree line will intersect the flange line and edge of the groove, and a line between these two points establishes the face of the whelp. Project these points back to the line through the center of the arc describing the contact plane on the whelp. Rotate these points about the center of the arc to establish their traces on the whelp.

Draw a line parallel to the centerline of link No. 1 and passing through its point of contact with the whelp.

The arcs describing the traces of the flange, the contact plane and the groove respectively, will intersect this line. (Figure 21).

Project their points normal to this line to their intersection with their respective traces in the top view of link No. 1. A line connecting these three points should be a curve and should be tangent to an arc about the center of the end radius of the link and passing through the intersection of the contact plane and the projection of the contact trace on the whelp.

If this curve is not tangent at the proper point, it will be necessary to establish a suitable curve and project its points of intersection back in reverse order and establish the corrected traces of the flange and edge of the groove. The contact trace will remain the same, but the angle previously established as  $35\frac{1}{2}$  degrees, will vary. This will, of course, change the trace of the groove and the trace of the flange on the whelp, and so they will have to be corrected to suit.

So far the layout has been limited to the development of a sectional view of the Wildcat taken on a plane passing through the center of the groove and parallel to the sides.

Another view must be developed, and it will be taken at the centerline of the first view and looking to the right.

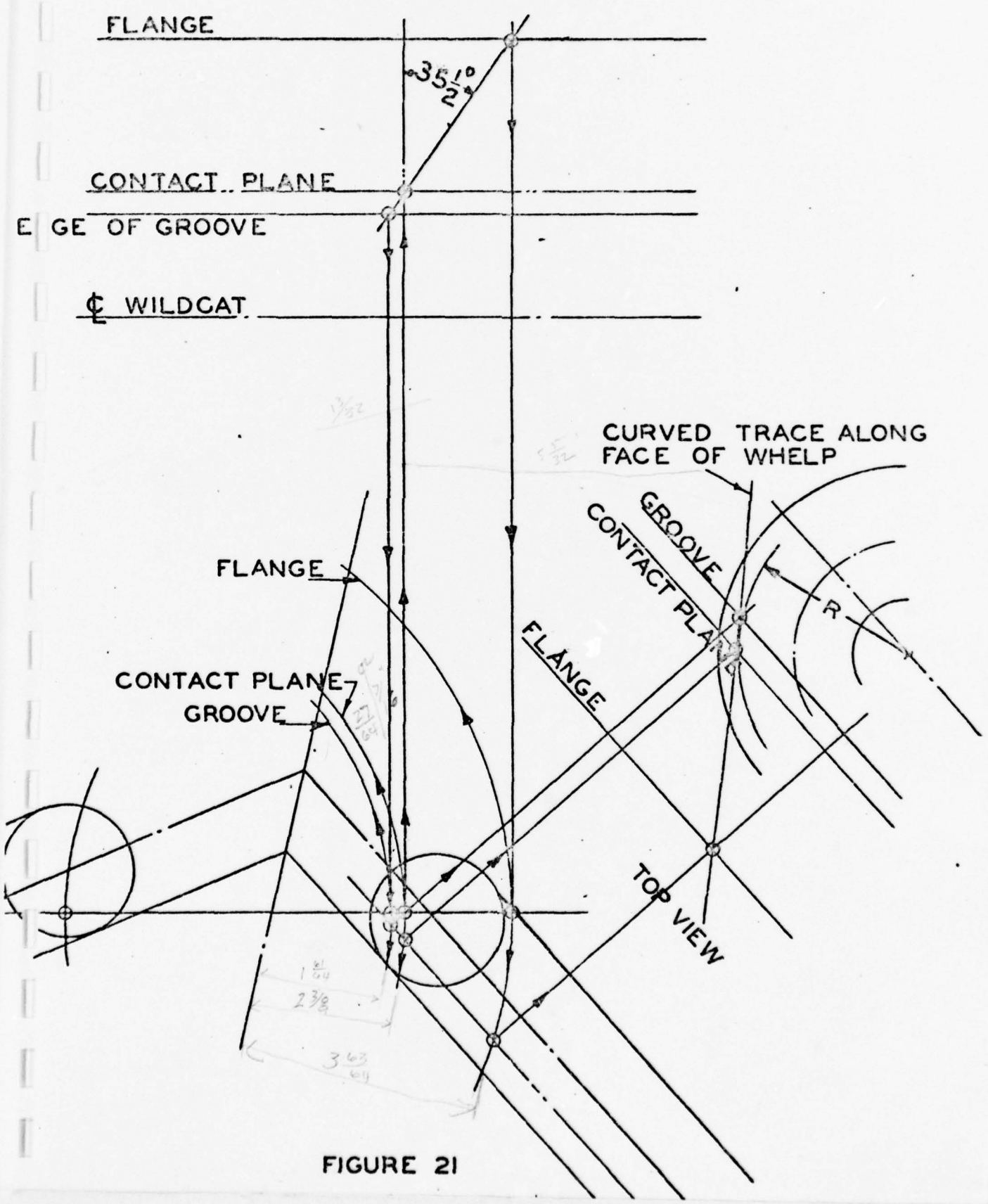

FIGURE 21

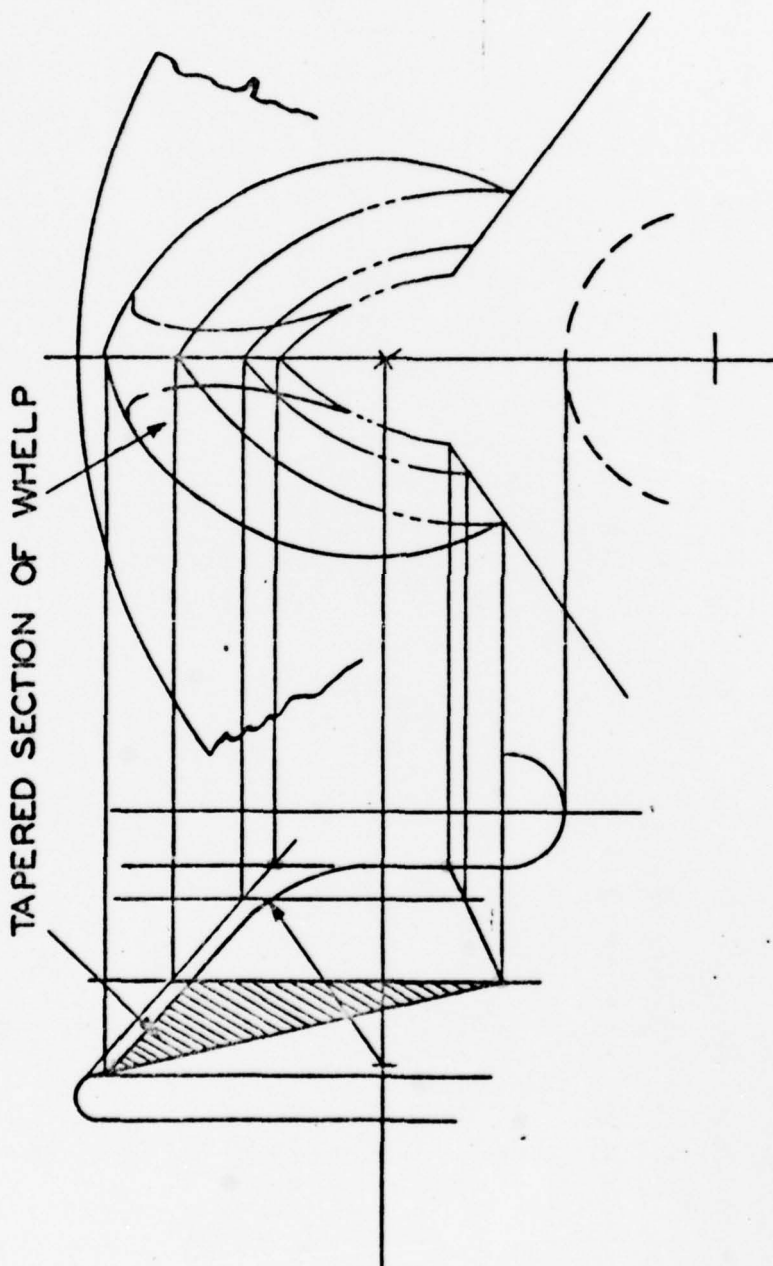

FIGURE 22

The intersection of the whelp traces must be projected to this view and they will establish the peak of the whelp. \* This peak line will be a straight line.

To remove the sharp corners, a radius is introduced into the whelp in this view. This changes the shape of the whelp beyond its point of contact with the link, and when the radius has been established the first view will have to be corrected to agree.

The flange walls of the pocket taper from the bottom of the pocket outward at an angle of 9 degrees, 23 minutes. This is an arbitrary dimension and may be varied to suit conditions.

This slope adds a tapered section to the whelp. The top edge of the whelp is made parallel to the developed peak, but due to the radius introduced, will be lower than the developed peak. The point where the top edge of the whelp intersects the walls, determines the approximate outside diameter of the Wildcat.

The flange walls are made up of five trapezoids that intersect at the apex of the pentagon and along the centerlines of the whelps.

A flat section of a circle must be added to the outer edges of the trapezoids to provide a circular periphery to the Wildcat. The fairing in of these surfaces and the outer tip of the whelp determines the diameter of the Wildcat. (See page 31).

The inner edge of the trapezoids must be faired into the hub of the Wildcat.

The remainder of the layout is standard development of the views desired.

In some cases the flange walls of the Wildcat are made conical. This changes the shape of the whelps and pockets slightly at their lines of intersection with the walls. But the sectional view becomes much more simple to lay out and some Pattern Makers find it easier to make the conical section than to develop the five trapezoids.

The conical walls have no effect on the operation of the Wildcat.

\*A straight line connecting the two points formed by the edge of the groove trace and flange line trace. This line will be a curve if it also passes through the contact plane trace.

Due to the wear of the dies, the links are inclined to be thicker at their centers than the nominal dimensions indicate. Therefore, to provide for links being thicker due to wear of the dies, the bottom of the pocket is made slightly lower in the center. The actual pocket is dropped below the developed bottom of the pocket. On the layout this line is usually shown about  $1/16$ " lower than the developed line and it parallels the developed line for a short distance, (one diameter plus  $1/2$  the end-play on each side of the pocket centerline), in either direction and then angles up to the root of the whelp at the edge of the groove.

The actual shape that the whelp assumes beyond its area of contact with the link is not always shown on the layout and is frequently left to the discretion of the Pattern Maker who faires it into the sides of the pocket and provides the necessary fillets, etc. However it is very important that the fillet at the root of the whelp be considerably less than one quarter of the chain diameter or it may cause the chain to bear high along the face of the whelp.

The Pattern Maker should make a model chain of 5 or 6 links for testing the Wildcat pattern. These links should conform to the dimensions of the "corrected" link used in the layout, and should be made to the same shrinkage scale as the Wildcat pattern.

The two halves of the Wildcat pattern should be joined together and be mounted on a horizontal shaft in such a manner as to permit the pattern to be rotated.

The model chain should then be placed in the Wildcat pattern and a check made to determine the relation between the length of the links and the pitch of the whelps. The links should make proper contact with two whelps when the model chain is in tension. Care must be taken to insure the proper seating of the flat links against the whelps.

Frequently it is possible to wrap the chain about the whelps and have three links contact three whelps simultaneously.

This condition would rarely occur in the actual operation of the Wildcat, but it is good proof of the accuracy of the design and pattern.

During the above test, it is important that the chain be under sufficient tension to maintain the correct distance between consecutive ends of the flat links, for if the chain is not kept taut, the vertical links will tend to drop and cause the distance between the consecutive end sections of the flat links to become shortened.



The pocket should be checked for end-play and clearance of the link between the flange walls, and the sides and bottom of the groove.

It is interesting to note the motion of the flat link as it enters the pocket. It first moves along a radius about the aft end section of the preceding flat link, but begins to knuckle about its own end section as it reaches the bottom of the pocket and finally is seen to lock itself against the contact point on the whelp.

In the event the Wildcat pattern is not satisfactory, it is possible to make corrections. The bottoms of the pockets may be either built up or shaved off, and it is possible to remove the whelps and correct them or replace them. However, there are several important points to be considered in the correcting of the Wildcat pattern.

1. Shaving off the faces of the whelps near the point of contact without making certain other alterations, does little or no good, as this merely moves the consecutive contact points to a new position and the distance between these points remains virtually the same. The end-play, however, would be increased.
2. The pitch of the whelps may be increased slightly by placing liners in the bottom of the pockets. This will cause the links to contact the whelps at a higher point and so the liners must be relatively thin for the whelps may lose their "holding capacity" nearer their tips. By lining the pockets, the end-play is slightly increased.
3. The pitch may be reduced slightly by shaving off the flats at the bottom of the pockets. This will, of course, reduce the end-play unless the whelps are shaved off at the same time.

Theoretically, the actual Wildcat might be corrected by following the same steps used for correcting the pattern, but the "doctoring" of a Wildcat is seldom successful although it is occasionally attempted.

The irregularity of the shapes involved eliminates the practicability of using templates. This makes it impossible to keep the alterations to all whelps and pockets identical, and the only guide to the operations is to continually check the whelps and pockets with the actual chain to be used.

Thus, the attempts to "doctor" a Wildcat are seldom successful enough to warrant the expenditure of the time and materials required.

It is therefore extremely important that accurate dimensions be obtained of the chain to be used, and great care must be exercised in both the layout and the construction of the pattern.

### CHAIN PITCH

The importance of chain pitch is frequently overlooked. Just as two spur gears must be of like pitch to mesh properly, the pitch of the chain must be the same as the pitch of the wildcat on which it is to operate.

Wildcats and chain are relatively large and clumsy and require relatively large tolerances, but these tolerances must be used with discrimination if satisfactory operation is to be obtained.

Since chain is commonly designated by the wire diameter, it should be noted that some commercial chains have wire dia. that vary from nominal dimensions by plus or minus  $1/16"$ . Thus it is important that link lengths be compared with the wire dia. in order to properly classify the chain as to size.

A chain having links  $2-1/8"$  dia. by  $12-5/16"$  long could not properly be considered a nominal  $2-1/8"$  chain since the overall length of the links would be  $7/16"$  short of the nominal length, ( $12-3/4"$ ). The pitch length of this chain is  $1/16"$  longer than the pitch length of  $2"$  dia. chain ( $12"-2 \times 2" = 8"$ ), and the overall length is shorter than  $2-1/16"$  chain ( $6 \times 2-1/16" = 12-3/8"$ ).

A wildcat designed to operate with this  $2-1/8"$  by  $12-5/16"$  chain should operate satisfactorily with  $2-1/16"$  chain;  $2"$  chain would be too tight and would tend to ride up on the whelps during walking out and would stick in the pockets during the hauling in. A nominal  $2-1/8"$  chain would be too long and have excessive play, causing rapid wear of both chain and wildcat.

Some manufacturers make chain having two types of links alternated (cast steel links connected by forged links, etc.). Frequently there is a variation between the pitch length of the two types of links.

In designing a wildcat for this type of chain, the layout can be made assuming all links to be of equal pitch, but must be checked by drawing in both combinations of links (cast steel link connecting two forged links and then a forged link connecting two cast steel links) to determine the actual fit of the chain on the wildcat.

ANCHOR CHAIN TYPES  
 $A=6D$   $P=4D$   $OA$  FOR 6 LINKS =  $26D$   
 (NOMINAL SIZES)

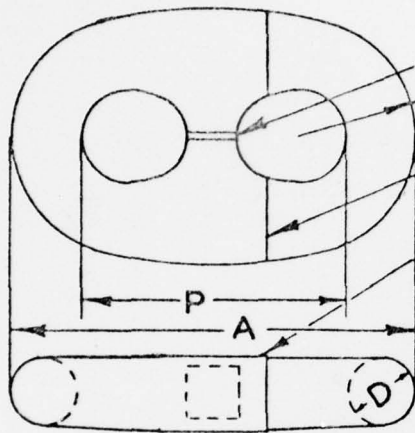

OPENING IN STUD  
 END RADIUS UNIFORM  
 LAP EDGE JOINT  
 THICKER AT CENTER

PITCH LENGTHS OF LINKS  
 VERY UNIFORM.  
 NAVY D.L. TO NOMINAL SIZE  
 BALDT D.L. SLIGHTLY SHORT

DIE-LOCK

STUD CAST AS INTEGRAL  
 PART OF LINK.

END RADIUS UNIFORM

CAST STEEL CHAIN IS  
 UNIFORM IN PITCH LENGTH  
 AND USUALLY SLIGHTLY  
 LONGER THAN NOMINAL  
 LENGTH.

CAST STEEL

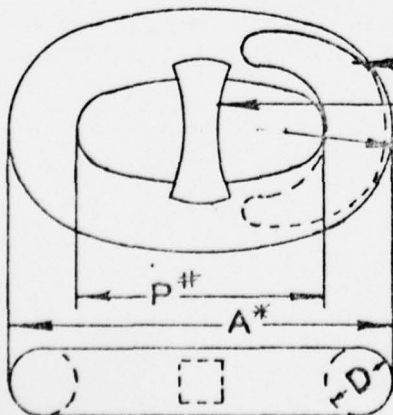
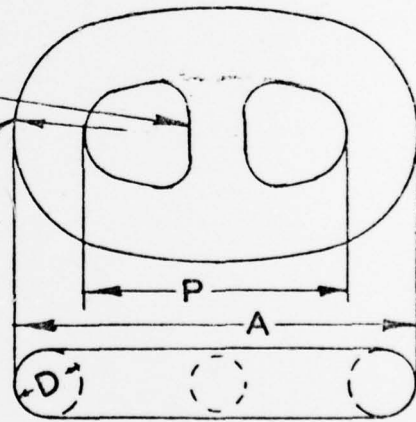

FORGE WELD  
 STUD INSERTED  
 END RADIUS NOT UNIFORM

\*  $A = 5.75$  (ABT)

#  $P = A - 2D$

OLD LOOSE STUD

COMMERCIAL LOOSE STUD

A = 6D (NOMINAL LENGTH)      P = 4D (NOMINAL PITCH)  
 OA 6 LINKS = 26D (NOMINAL)

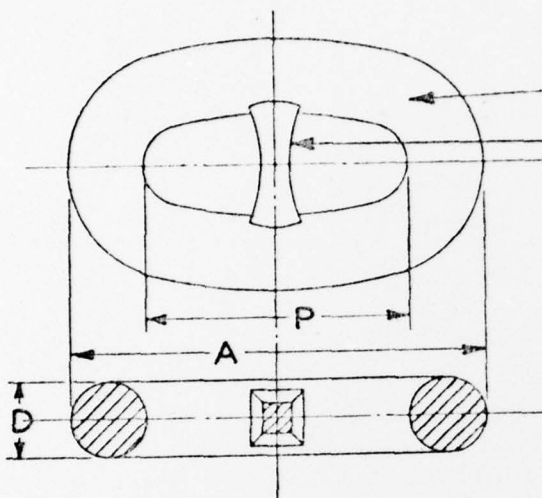

FORMED WIRE  
 INSERTED STUD

NOMINAL DIMENSIONS  
 (LENGTH) SAME AS NAVY  
 DIE-LOCK.

TOLERANCES ARE AM. BUSHIP  
 AND FREQUENTLY EXCEED  
 NAVY ALLOWABLE + & -  
 TOLERANCES.

BODY OF LINK IS OF  
 FORMED WIRE.

COMMON TYPES

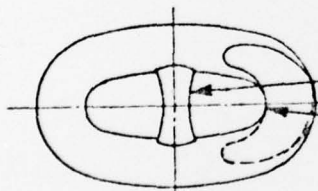

STUD INSERTED (LOOSE OR WELDED)  
 LAP WELD

1. FORGED STEEL - JOINT LAP WELDED AT END

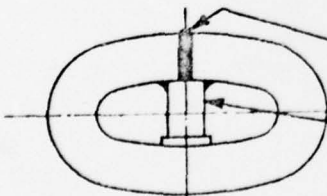

BUTT WELDED  
 STUD INSERTED & WELDED

2. ELECTRIC WELD - ONE JOINT BUTT WELDED

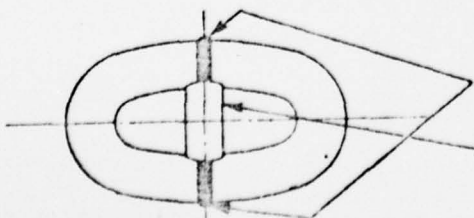

CONTACT WELDS  
 STUD INSERTED & WELDED

3. FLASH WELD - TWO "U" SHAPED WIRES CONTACT OR  
 FLASH WELDED

## LOCATION OF CHAIN PIPE

Recent investigation of unsatisfactory operation of anchor windlass has directed attention to the importance of the relative location of the chain pipes in regards to the wildcats.

Some windlass manufacturers locate the chain pipes so that the chain falls in a plumb line from the after side of the wildcat. This is apparently done to permit the chain to enter or leave the chain locker freely.

An important factor effecting the operation of wildcats is the balance of forces acting on the chain. The pull exerted by the outboard portion of chain tends continually to cause the bearing link to slip over the whelp, while the inboard portion of chain continually exerts a pull tending to prevent the bearing link from slipping.

A diagram showing the various forces acting on the bearing link indicates that a very small force exerted by the inboard chain will over balance a relatively large force exerted by the outboard chain. This is, of course, largely due to the friction between the whelp and the bearing link.

In the American type wildcat, the shape of the whelp is such that it would be nearly impossible for the bearing link to be pulled over the whelp supporting the load exerted by the outboard chain. The link could only be made to slip over the whelp when the lines of force acting on the link caused it to tilt and then roll up on the face of the whelp. The force tending to tilt the link acts thru the wire center at the forward end of the link and since the link must roll on the face of the whelp, the length of the lever tending to tilt the link is the normal distance from the line of force to the contact point on the link.

As the link tilts, this distance continually decreases, and eventually becomes zero when the longitudinal axis of the link lies in the same plane as the line of force. Of course, as the link rolls up on the face of the whelp, the angle of contact reduces and less effort is required to overcome the friction tending to prevent the link from sliding over the tip of the whelp. But as the force increases, the friction between the whelp and link also increases. For this reason it is nearly impossible to force chain to slip over an American type wildcat while it is not in motion.

While the chain is being walked out, the bearing link continually tends to tilt and in doing so, pulls the following flat link into a position which prevents it from entering its chain pocket freely.

This link rides high on the face of the whelp and thus prevents the next flat link from entering its chain pocket. This flat link finally comes to a bearing position but is lying on top of the whelps rather than behind them and the pull of the chain causes this link to slide over the whelps.

A relatively small increase in the pull exerted by the inboard portion of the chain will prevent the bearing link from tilting.

By locating the chain pipes below the centerline of the wildcat shaft, a slight drag on the chain is created and which is usually sufficient to overcome the tilting action of the bearing links and this prevents slippage of the chain, thru the wildcats. The over hanging weight of the inboard chain is also an important factor and in some cases the balance between the inboard and outboard chain pull has been so nearly equal in effect, that the chain only slipped when the chain was piled up high in the locker and reduced the amount of overhanging chain.

Studies made of the European type wildcat indicate that a similar condition exists. However, the angle of inclination at the point of contact between the bearing link and whelp is not nearly so great as in the American type and the chain can be made to slide along the face of the whelp with a relatively small force exerted by the outboard chain.

Once the bearing link begins to slide, it has lost its holding power and the following flat link must begin to support the load. The line of force acting thru the forward end of this link tends to tilt the link, causing it to roll along the face of the whelp. When the force exerted by the outboard portion of the chain is very great, there is a possibility of this link rolling over the tips of the whelps and permitting the chain to slip thru the wildcat.

This condition would exist in the European type wildcat, both while stationary and while rotating so as to walk the chain out.

POINT OF CONTACT LIES BELOW LINE OF FORCE AND LINK TENDS TO TILT.

LINE OF FORCE

OTBD.  
PULL

POINT OF CONTACT

DOTTED LINES SHOW HOW TILTING LINK CAUSES FOLLOWING FLAT LINK TO LIE ON WHELP RATHER THAN SEAT IN CHAIN POCKET AS THE CHAIN IS BEING WALKED OUT.

WITH CHAIN PIPE LOCATED BELOW  $\phi$  OF WILDCAT, CHAIN LEAD TENDS TO PREVENT TILTING OF LINK AND INCREASES DRAG ON CHAIN AS IT LEAVES THE CHAIN LOCKER.

EUROPEAN TYPE WILDCAT SHOWN

TO CHAIN PIPE LOCATED AFT. OF WILDCAT

TO CHAIN PIPE LOCATED ON  $\phi$  OF WILDCAT

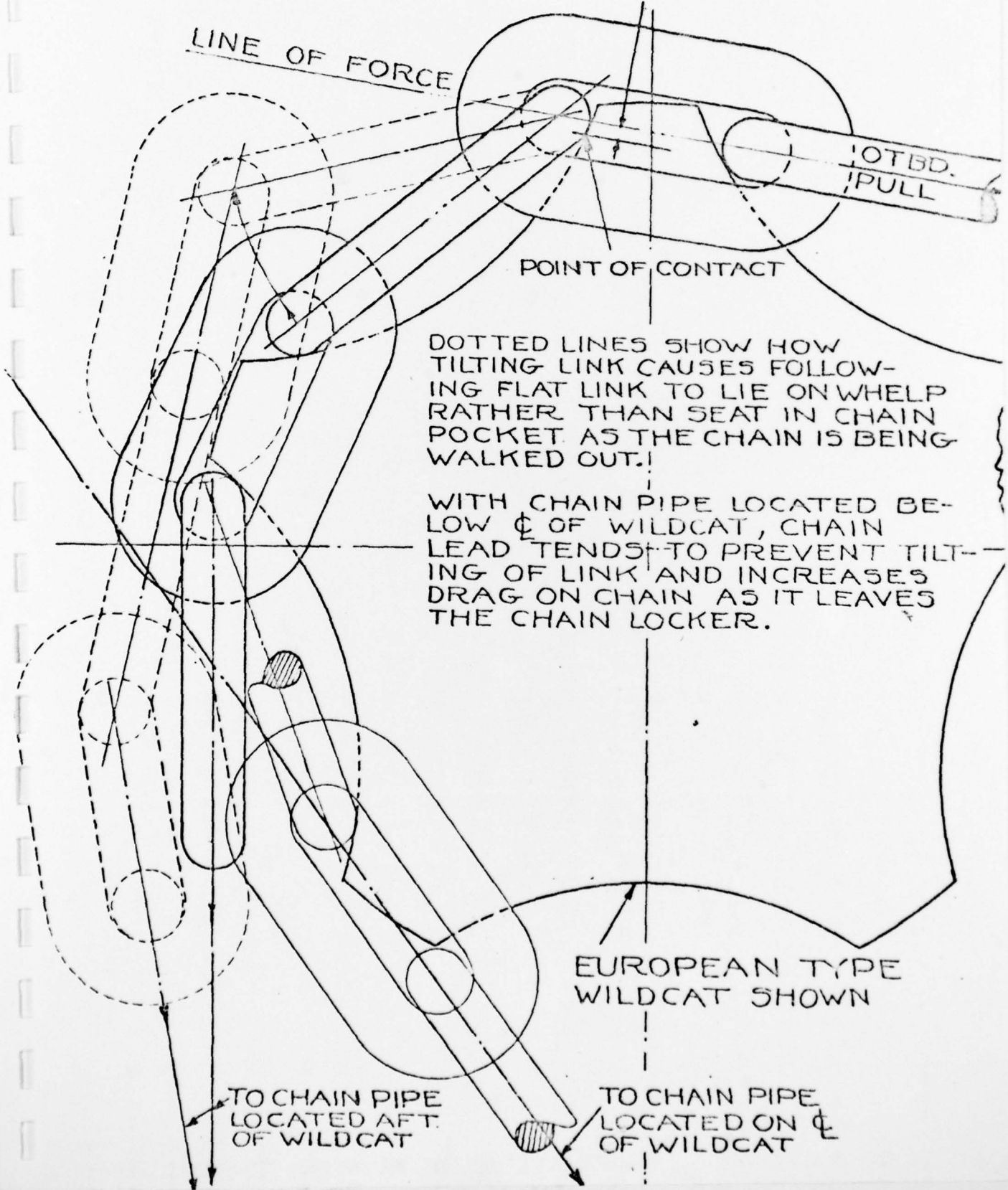

## INDEX

| Figures   | Page |
|---|------|
| 1 Chain Motion  | 8    |
| 2 Chain Motion  | 8    |
| 3 Chain Motion  | 8    |
| 4 Chain Motion  | 8    |
| 5 Length of link determines length of side                  | 10   |
| 6 Pentagon inscribed in a circle                            | 10   |
| 7 Length of link determines size of pentagon                | 12   |
| 8 Length of link determines size of pentagon                | 12   |
| 9 Chain Tolerances  | 14   |
| 10 Illustrating End Play                                    | 14   |
| 11a Illustrating insufficient minus clearance               | 14   |
| 11b Illustrating insufficient end-play                      | 14   |
| 11c Section through whelp                                   | 17   |
| 12 Face angle of whelp                                      | 18   |
| 13a Plane intersecting whelp                                | 18   |
| 13b Plane intersecting whelp                                | 18   |
| 14 Locating contact plane                                   | 20   |
| 15 Correcting pentagon for minus tolerances                 | 23   |
| 16 Correcting pentagon for minus tolerances                 | 23   |
| 17 Traces of horizontal and vertical contact planes on link | 27   |
| 18 Top view of link   | 28   |
| 19 Contact trace of whelp                                   | 30   |
| 20 Illustrating trapezoid sides of Wildcat                  | 31   |
| 21 Establishing face angle of whelp                         | 33   |
| 22 Illustrating tapered section of whelp                    | 34   |
| 23 Typical Wildcat layout                                   | 37   |

| INDEX   | Page       |
|---|------------|
| Chain Motion . . . . .                              | 8, 9       |
| Chain Pipes - Location of . . . . .                 | 42         |
| Chain Pitch . . . . .                               | 39         |
| Chain Tables . . . . .                              | 48         |
| Chain Tolerances . . . . .                          | 14, 15     |
| Chain Types . . . . .                               | 40, 41     |
| Chain Wrapped Around a Regular Polygon . . . . .    | 9          |
| Clearance at Pocket Bottom . . . . .                | 36         |
| Clearance - Insufficient, Plus and Minus . . . . .  | 14         |
| Contact Curve . . . . .                             | 26, 33     |
| Contact Plane - Location of . . . . .               | 20, 21, 26 |
| Contact Plane - Trace on Links . . . . .            | 27, 28     |
| Contact Planes - Trace on Whelps . . . . .          | 30         |
| End-Play . . . . .                                  | 14, 22     |
| Flange - Traces of . . . . .                        | 29, 32, 35 |
| Flange Walls - Circular Section Added . . . . .     | 31, 35     |
| Flange - Width of . . . . .                         | 21         |
| Groove - Illustration . . . . .                     | 10         |
| Groove - Traces of . . . . .                        | 29, 32     |
| Groove - Width of . . . . .                         | 29, 21     |
| Historical Notes . . . . .                          | 3          |
| Link - Clearance at Whelp . . . . .                 | 30         |
| Link - Correcting for Minus Tolerance . . . . .     | 22         |
| Link - Traces of Contact Plane . . . . .            | 27         |
| Links - Tilting of . . . . .                        | 44         |
| Mahadeen Formula - Correcting Pentagon . . . . .    | 24, 25     |
| Pentagon - Correcting for Minus Tolerance . . . . . | 22, 24     |
| Pentagon Inscribed in a Circle . . . . .            | 10, 11     |

| INDEX  | Page         |
|--|--------------|
| Pentagon - Length of Link Determines Size . . . . .      | 12, 13       |
| Pentagon - Reason for . . . . .                          | 11           |
| Pocket Bottom - Clearance at . . . . .                   | .36          |
| Polygon - Length of Link Determines Length of Side . . . | .10          |
| Tolerance - Plus and Minus . . . . .                     | .16, 24      |
| Whelps - Bearing Face . . . . .                          | 14 (Fig. 10) |
| Whelps - Face Angle . . . . .                            | 18, 33       |
| Whelps - Link Clearance . . . . .                        | 30           |
| Whelps - Pitch of and Minus Tolerance . . . . .          | 16, 21       |
| Whelps - Plane Intersecting . . . . .                    | 18           |
| Whelps - Point of Tangency . . . . .                     | .19          |
| Whelps - Radius to Remove Sharp Corners . . . . .        | 34, 35       |
| Whelps - Section Thru . . . . .                          | 17           |
| Whelps - Shape of . . . . .                              | 19           |
| Whelps - Tapered Section of . . . . .                    | 34, 35       |
| Whelps - Trace of Contact Plane . . . . .                | 30, 32       |
| Wildcat - American Type . . . . .                        | 4, 5         |
| Wildcat - Conical and Trapezoid Sides . . . . .          | 31, 35       |
| Wildcat - "Doctoring" . . . . .                          | 38           |
| Wildcat - English Type . . . . .                         | 4, 6         |
| Wildcat - European Type . . . . .                        | 4, 7         |
| Wildcat - Laying Out . . . . .                           | .11          |
| Wildcat - Layout - Checking for Plus Tolerance . . . . . | .24          |
| Wildcat Pattern - Checking . . . . .                     | .36          |
| Wildcat Pattern - Correcting . . . . .                   | .38          |
| Wildcat - Pitch of . . . . .                             | 21           |
| Wildcat - Types of . . . . .                             | 4            |
| Wildcat - Typical Layout . . . . .                       | .37          |

DIE-LOCK

CAST STEEL

LOCCE STUD

| SIZE  | PROOF STRESS | BREAK STRESS | PROOF STRESS | BREAK STRESS | PROOF STRESS | BREAK STRESS |
|-------|--------------|--------------|--------------|--------------|--------------|--------------|
| 3/4   | 21,000       | 35,000       | 32,500       | 47,500       | 48,000       | 75,000       |
| 7/8   | 29,000       | 48,500       | 46,120       | 64,570       | 64,000       | 98,000       |
| 1     | 38,800       | 64,600       | 60,000       | 84,000       | 84,000       | 129,000      |
| 1-1/8 | 48,500       | 80,900       | 75,540       | 105,760      | 106,000      | 161,000      |
| 1-1/4 | 59,300       | 98,900       | 92,770       | 129,880      | 130,000      | 198,000      |
| 1-3/8 | 71,200       | 116,600      | 111,660      | 156,330      | 157,000      | 235,000      |
| 1-1/2 | 84,000       | 140,000      | 132,190      | 185,060      | 185,000      | 280,000      |
| 1-5/8 | 97,800       | 163,000      | 154,310      | 216,030      | 216,000      | 325,000      |
| 1-3/4 | 112,700      | 187,800      | 178,000      | 249,210      | 249,000      | 379,000      |
| 1-7/8 | 128,500      | 214,200      | 203,250      | 284,540      | 285,000      | 432,000      |
| 2     | 145,400      | 242,300      | 230,000      | 322,000      | 322,000      | 488,000      |
| 2-1/8 | 163,200      | 272,000      | 258,240      | 361,530      | 362,000      | 548,000      |
| 2-1/4 | 182,000      | 303,300      | 287,930      | 403,100      | 403,000      | 610,000      |
| 2-3/8 | 210,700      | 336,200      | 319,050      | 446,660      | 447,000      | 675,000      |
| 2-1/2 | 222,500      | 370,800      | 351,560      | 492,190      | 492,000      | 744,000      |
| 2-5/8 | 244,200      | 407,000      | 385,440      | 539,620      | 540,000      | 813,000      |
| 2-3/4 | 266,800      | 444,700      | 420,660      | 588,930      | 589,000      | 888,000      |
| 2-7/8 | 290,500      | 484,100      | 457,190      | 640,070      | 640,000      | 964,000      |
| 3     | 315,000      | 525,000      | 495,000      | 693,000      | 693,000      | 1,045,000    |
| 3-1/8 | 340,500      | 567,500      | 534,060      | 747,680      | 747,000      |              |
| 3-1/4 | 367,000      | 612,000      | 574,340      | 804,070      | 804,000      |              |
| 3-3/8 | 394,000      | 657,000      | 615,800      | 862,130      | 862,000      |              |
| 3-1/2 | 422,000      | 704,000      | 658,440      | 921,810      | 921,000      |              |