

AD-A072 504

LASER DIODE LABS INC METUCHEN N J  
INJECTION LASER DIODES FOR FIBER OPTIC COMMUNICATIONS.(U)  
JUN 78 R ADAIR

F/G 9/1

DAAB07-76-C-0040

UNCLASSIFIED

NL

/OF |

AD  
A072504



END

DATE

FILMED

9-79

DDC

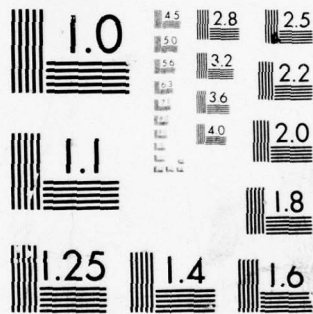

MICROCOPY RESOLUTION TEST CHART  
NATIONAL BUREAU OF STANDARDS-1963-A

AD-A038 678

# LEVEL <sup>III</sup>

②

MANUFACTURING METHODS AND TECHNOLOGY ENGINEERING  
PROGRAM QUARTERLY TECHNICAL REPORT

A072504

Contract Number DAAB07-76-C-0040

INJECTION LASER DIODES FOR FIBER OPTIC COMMUNICATIONS

Prepared By:

LASER DIODE LABORATORIES, INC.  
205 Forrest Street  
Metuchen, New Jersey 08840

DDC  
R  
AUG 9 1979  
C

DDC FILE COPY

Fifth Quarterly Report  
for the Period 1 July 1977 to 30 September 1977

Approved for public release; distribution unlimited.

Placed by:

U. S. Army Electronics Research and Development Command  
Fort Monmouth, N. J. 07703

79 08 06 114

MANUFACTURING METHODS AND TECHNOLOGY ENGINEERING  
PROGRAM QUARTERLY TECHNICAL REPORT

Contract Number DAAB07-76-C-0040

INJECTION LASER DIODES FOR FIBER OPTIC COMMUNICATIONS

Prepared by:

Rob Adair  
Applications Engineer

LASER DIODE LABORATORIES, INC.  
205 Forrest Street  
Metuchen, New Jersey 08840

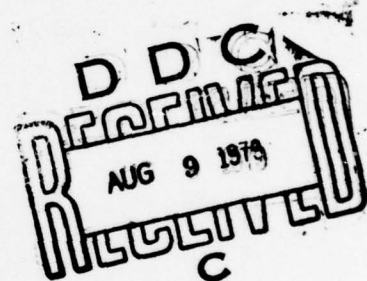

Fifth Quarterly Report  
for the Period 1 July 1977 to 30 September 1977

This project has been accomplished as part of the US Army Manufacturing and Technology Program, which has as its objective the timely establishment of manufacturing processes techniques or equipment to insure the efficient production of current or future programs.

The findings in this report are not to be construed as an official Department of the Army position unless so designated by other authorized documents.

Destroy this report when it is no longer needed. Do not return it to the originator.

UNCLASSIFIED

SECURITY CLASSIFICATION OF THIS PAGE (When Data Entered)

REPORT DOCUMENTATION PAGE		READ INSTRUCTIONS BEFORE COMPLETING FORM
1. REPORT NUMBER	2. GOVT ACCESSION NO.	3. RECIPIENT'S CATALOG NUMBER
4. TITLE (and Subtitle) INJECTION LASER DIODES FOR FIBER OPTIC COMMUNICATIONS		5. TYPE OF REPORT & PERIOD COVERED Quarterly Report 7/1/77 to 9/30/77
7. AUTHOR(s) Rob/Adair		6. PERFORMING ORG. REPORT NUMBER
9. PERFORMING ORGANIZATION NAME AND ADDRESS Laser Diode Laboratories, Inc. 205 Forrest Street Metuchen, New Jersey 08840		8. CONTRACT OR GRANT NUMBER(s) DAAB07-76-C-0040
11. CONTROLLING OFFICE NAME AND ADDRESS US Army Elec. Res. & Dev. Command Fort Monmouth, New Jersey 07703 ATTN: DELSD-D-PC		10. PROGRAM ELEMENT, PROJECT, TASK AREA & WORK UNIT NUMBERS 2769778
14. MONITORING AGENCY NAME & ADDRESS (if different from Controlling Office) 11 15 Jun 78		12. REPORT DATE 6/15/78
		13. NUMBER OF PAGES 39
		15. SECURITY CLASS. (of this report) Unclassified
		15a. DECLASSIFICATION/DOWNGRADING SCHEDULE
16. DISTRIBUTION STATEMENT (of this Report) Approved for public release; distribution unlimited. 12 42 p		
17. DISTRIBUTION STATEMENT (of the abstract entered in Block 20, if different from Report) 9 Quarterly rept. no. 5, 1 Jul-30 Sep 77,		
18. SUPPLEMENTARY NOTES		
19. KEY WORDS (Continue on reverse side if necessary and identify by block number) Injection Laser Diodes Fiber Optic Communications Gallium Aluminum Arsenide Double Heterojunction Laser Diode		
20. ABSTRACT (Continue on reverse side if necessary and identify by block number) The design and fabrication of injection laser diodes for use in fiber optic communications is discussed with regard to material synthesis, chip configuration, and device assembly in manufacturing environment. The opto-electronic source is based on the GaAs-GaAlAs double heterojunction structure and consists of a parallel array of lasers formed by the application of triple stripe geometry to the surface of the epitaxial wafer. The		

UNCLASSIFIED

SECURITY CLASSIFICATION OF THIS PAGE (When Data Entered)

i 405 626

elt

UNCLASSIFIED

SECURITY CLASSIFICATION OF THIS PAGE(When Data Entered)

monolithic triad of discrete lasing elements is mounted in a high frequency package which incorporates a high quality optical window.

Accession For	
NTIS CRA&I	<input checked="" type="checkbox"/>
DDC TAB	<input type="checkbox"/>
Unannounced	<input type="checkbox"/>
Justification	
By _____	
Distribution/	
Availability Codes	
Dist	Avail and/or special
A	

UNCLASSIFIED

SECURITY CLASSIFICATION OF THIS PAGE(When Data Entered)

14. KEY WORDS	LINK A		LINK B		LINK C	
	ROLE	WT	ROLE	WT	ROLE	WT
Injection Laser Diodes Fiber Optic Communications Gallium Aluminum Arsenide Double Heterojunction Laser Diode						

UNCLASSIFIED

Security Classification

TABLE OF CONTENTS

<u>Section</u>		<u>Page</u>
I	Introduction . . . . .	1
II	Manufacturing Methods and Technology Engineering . . . . .	2-23
2.1	Materials . . . . .	2
2.2	Test Equipment . . . . .	2-19
2.3	Device Performance . . . . .	19-23
III	Summary . . . . .	24

LIST OF FIGURES

<u>Figure</u>		<u>Page</u>
1	Burn-In Position Board with Edge Connector Fingers . . . . .	3
2	Transistor 10 ns Pulser . . . . .	5
3	Transistor Test Pulser Assembly . . . . .	6
4	Double Exposure Illustrating Adjustment of Goniometer Pulser Through 90° . . . . .	7
5	Clock and Control Circuit for Transistor Pulser .	8
6	APD Power Detector System . . . . .	11
7	Avalanche Diode Regulator . . . . .	12
8	Internal Structure Power Detector Head . . . . .	13
9	HV Supply for Power Measuring System . . . . .	14
10	Measurement of Beam Width . . . . .	16
11	Photo of EG&G with Pulser on Goniometer on Rail .	17
12	Double Exposure Illustrating Goniometer Operation	18
13	Laser from Wafer DHA-134 far Field Plot . . . . .	22

LIST OF TABLES

<u>Table</u>		<u>Page</u>
1	Ft. Monmouth Laser Program - Burn-In 2nd Engineering Samples . . . . .	20
2	Typical Devices from Wafer DHA-134 . . . . .	21

APPENDICES

Page

A. Engineering Man-Hour Utilization for the  
Fifth Quarter of the Program . . . . . 25

B. Distribution List . . . . . 26-32

SECTION I  
INTRODUCTION

The primary objective of this Manufacturing Method and Technology Engineering Program is threefold. First, the Injection Laser Diode for use in Fiber Optic Communications as outlined in Specification SCS-516 must be transferred from a developmental device type to a volume manufactured commercial product without adversely affecting the performance characteristics of the device. Secondly, the manufacturing methods and techniques necessary for the volume production of the laser diode must be developed and implemented to insure the highest degree of device quality and reliability at a reasonable cost. Thirdly, verification of device performance and quality for injection lasers produced in a volume manufacturing environment must be carried out by means of rigorous testing and evaluation to demonstrate the technical adequacy of the manufacturing methods developed under this contract.

Major objectives for the fifth quarter of the program included the completion of pre burn-in testing of devices for the second engineering sample, burn-in of those devices, and initiation of the 2000 hour life test. Further work was done on all aspects of the test equipment, particularly in the construction of equipment for power, thermal impedance, and wavelength testing. Effort was also directed toward definition of specific test methods and procedures to be included in the test plan. While burn-in rack operation has continued without system failure, temporary air deflectors were found necessary to deal with excess heating of critical components.

## SECTION II

### MANUFACTURING METHODS AND TECHNOLOGY ENGINEERING

#### 2.1 MATERIALS

Wafer production continues at a rate necessary to fulfill the anticipated needs for confirmatory sample devices. Wafer DHA-134 was evaluated as satisfactory and test results are reported under Device Testing.

The e-gun was removed from the vacuum system and sent to the manufacturer for repair and calibration. Upon its return, tests performed to check its operation revealed that although some of the problems were cleared up, the system would not be capable of the required performance. Therefore, an e-gun from a different manufacturer has been ordered, to be delivered in November.

#### 2.2 TEST EQUIPMENT

The equipment for the program continues to see steady progress, minor setbacks notwithstanding. The burn-in rack has proven to be reliable, but excess heating of critical components has been observed. Temporary air deflectors have alleviated the problem somewhat, but further expansion (past 16 positions) must await a better solution to the problem. Although various methods of improved ventilation are under consideration, no further work is anticipated until completion of the 2000 hour life test which is currently in progress. The only other change made to the design of the burn-in rack during this quarter is the addition of card

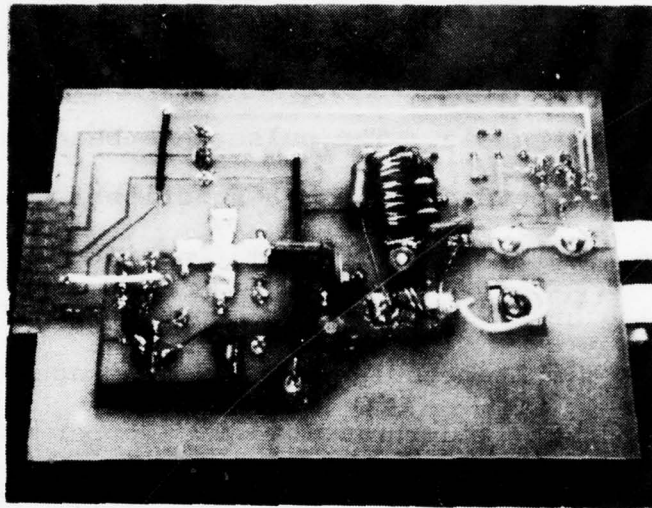
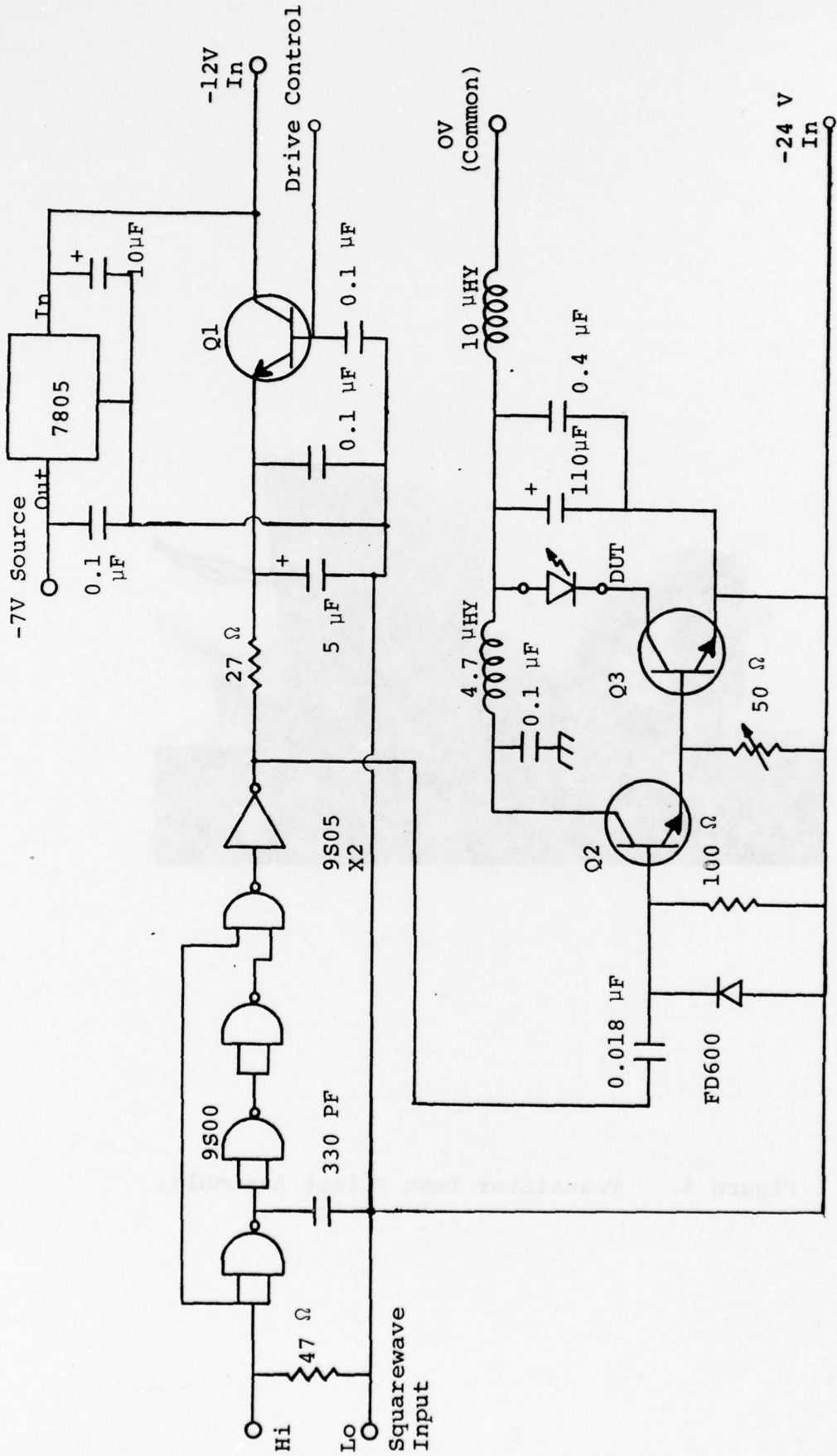

Figure 1. Burn-In Position Board with Edge Connector Fingers.

edge connectors. (See Figure 1) In addition to simplifying the wiring harness of each row of eight positions, card edge connectors reduce the problem of removal and exchange of individual positions from a major rewiring job to simply sliding the position boards in and out of their respective slots.

The transistor pulser design previously reported (Figure 2) has been tested extensively in use atop the goniometer (Figure 3) and its performance continues to be acceptable. The pulser has been integrated from its breadboard form into a functional housing incorporating heatsinking aluminum fins into the top of the housing and a large copper block at the front which serves simultaneously as a pill package holder, electrical contact, and thermal sink. Copper was chosen for its high thermal conductivity and high volume specific heat. The size of the block was chosen to allow no more than 1°C rise through a two minute test cycle. Its bottom section is radiused to permit 90 degree rotation thus allowing far field scans in any plane from perpendicular through parallel, as illustrated in Figure 4. A substantially identical pulser for use in the thermally controlled test fixture has, however, encountered some problems. Minor differences in physical layout and grounding appear to have major effects on the stability of the system such that the amplitude of the laser current pulse exhibits discontinuous jumps as the nominal drive level is increased.



- Notes:
1. N.B. Unconventional Supply Arrangements
  2. 9S05 Has All Gates in Parallel
  3. Q1 = TIP29C
  4. Q2 = CD1194
  5. Q3 = CD1197

Figure 2. Transistor 10 ns Pulser.

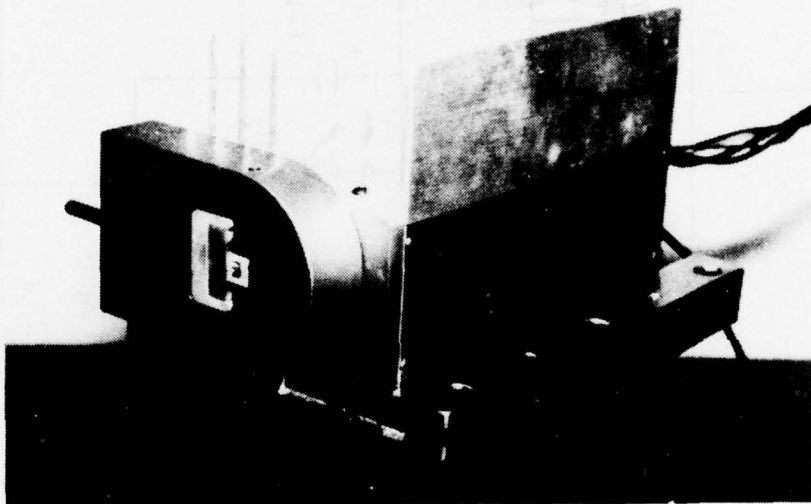

Figure 3. Transistor Test Pulser Assembly.

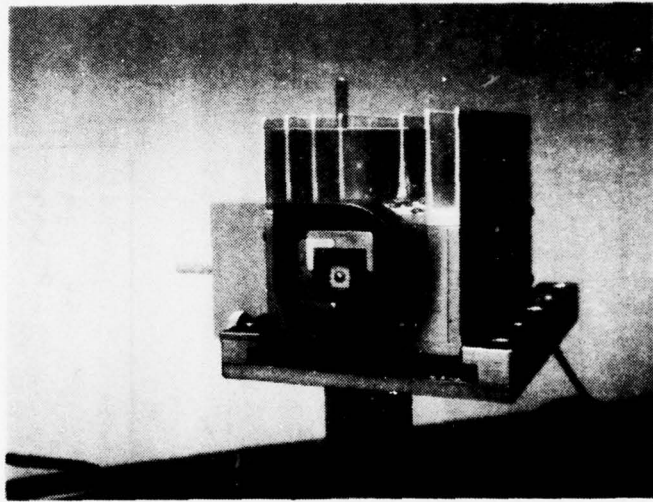
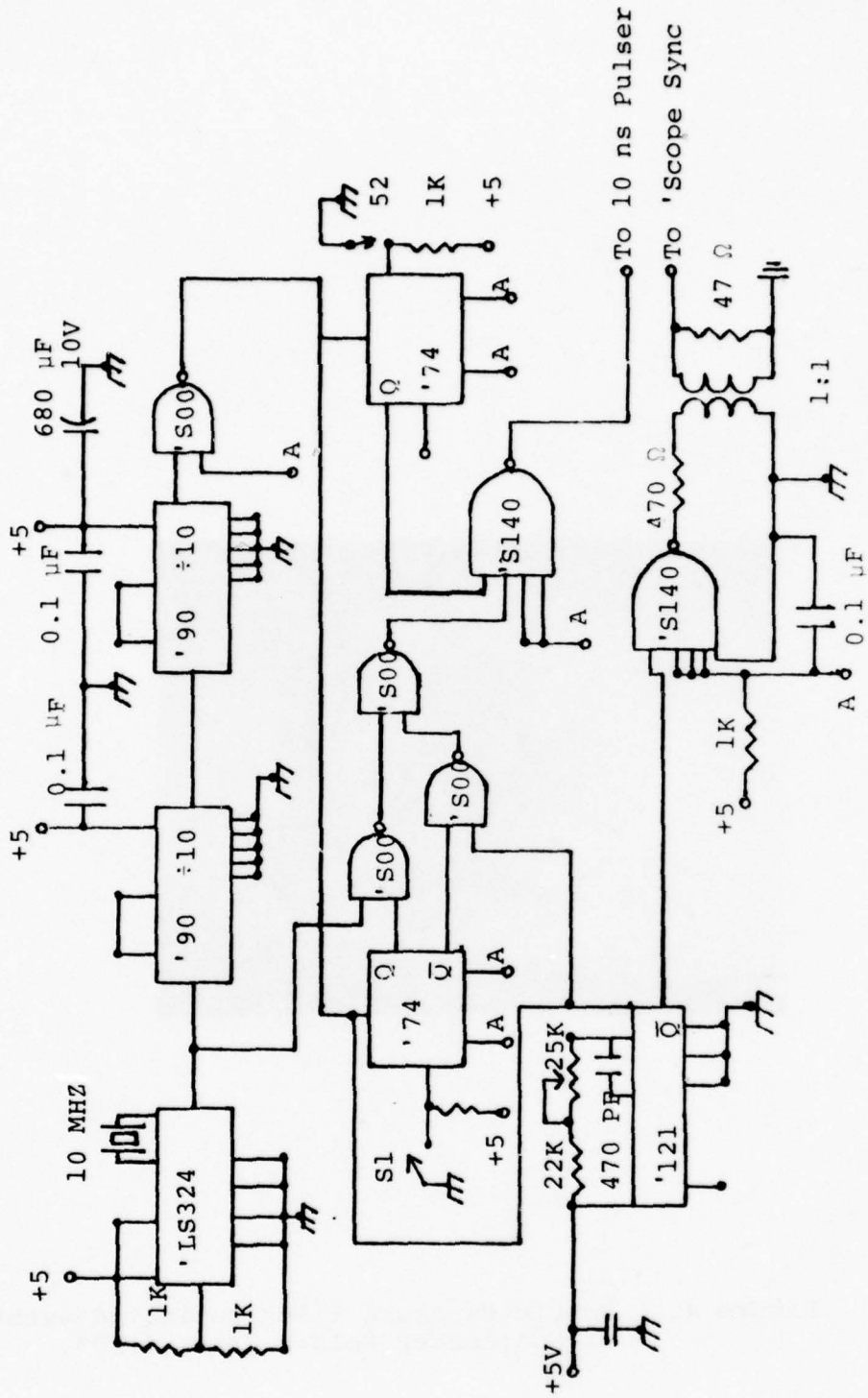

Figure 4. Double Exposure Illustrating Adjustment of Goniometer Pulser Through  $90^\circ$ .



Notes:

1. All Caps 0.1 F Unless Otherwise Noted.
2. All Logic 7400 Series TTL.

Figure 5. Clock and Control Circuit for Transistor Pulser.

Also, in one instance, outright oscillation has occurred. Empirical procedures in attempting to solve the problem have proven tedious and time consuming, with the frustration compounded by the good behavior of the first (substantially identical) pulser. Fortunately, the problems appear to have been solved, and construction was not substantially delayed in any event because other components in the system had not yet arrived. The clock/control circuit (Figure 5) for the transistor pulser is a TTL based design, capable of supplying 10 MHz for 10% duty factor operation, or 100 KHZ for 0.1% duty factor operation. The master oscillator operates at 10 MHz and is crystal controlled. Two decade down counters in succession divide the 10 MHz by 100 to obtain the 100 KHZ. The circuit is fully buffered and uses standard switch de-bouncing techniques. A time-delayed synchronizing signal is furnished via a monostable multivibrator so that the sampling oscilloscope may be properly triggered when using the system at 100 KHZ. The time delay is variable up to about 8  $\mu$ s and is necessary because the sampling oscilloscope can display only a narrow (0.1  $\mu$ s) window when set to 5 or 10 ns per division. The proportional controller, power supplies, and fixturing for the temperature controlled pill package pulse head are all on hand. The controller is an Oven Industries Model 4C2-15 which uses an Oven Industries TP20-6 thermistor to

sense the controlled temperature. This controller requires 4 DC supplies to operate, two five volt (standard power model SPS75-5) and two twelve volt (standard power model SPS30-12). The controller, its four supplies, a three position switch to permit selection of two pre-set temperatures or variable control, and a circuit to indicate when the temperature setpoint has been reached, are all to be installed together in a suitable cabinet whose internal layout is under design. The temperature control element is a thermoelectric module (Melcor Model CP2-31-10) driven by the controller in bipolar mode to provide either heating or cooling as required to achieve the desired test temperature. The temperature control system has been tested in breadboard and works satisfactorily throughout its operating range.

The power measuring apparatus previously reported (Figures 6 and 7 ) continues to work well. All of the necessary components for its operation have been assembled and it is complete. The apparatus is built in two parts. One of these is the detector box (Figure 8) and it houses the TIED 88 and APD as well as its compensating regulator. The other part houses the HV power supply (Figure 9). The detector box has a rectangular aperture 1.09 cm x 0.394 cm as specified in SCS-516. Mounted behind this aperture is a piece of diffusing film (3M LDF 3008N). The APD is mounted

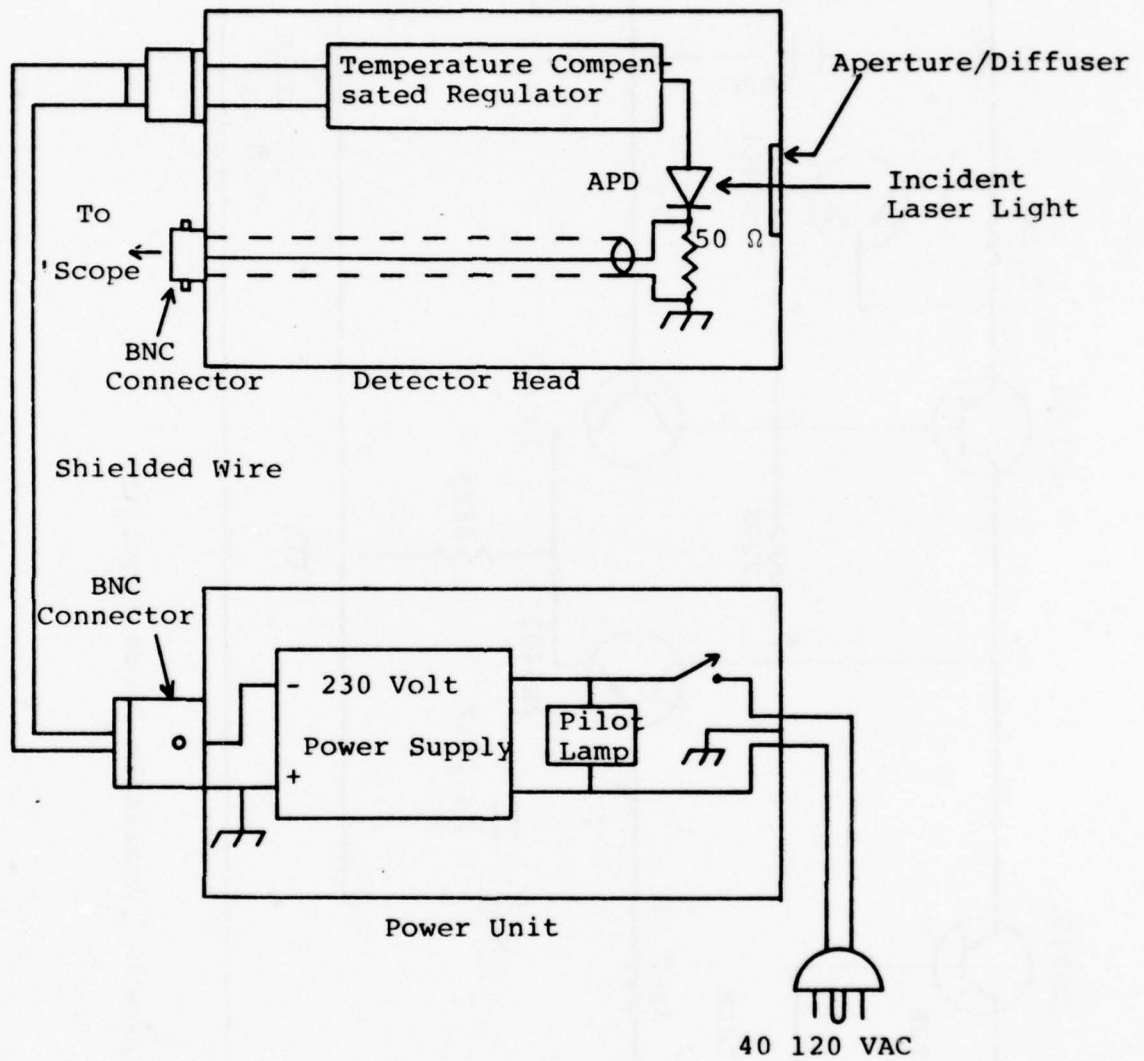

Figure 6. APD Power Detector System.

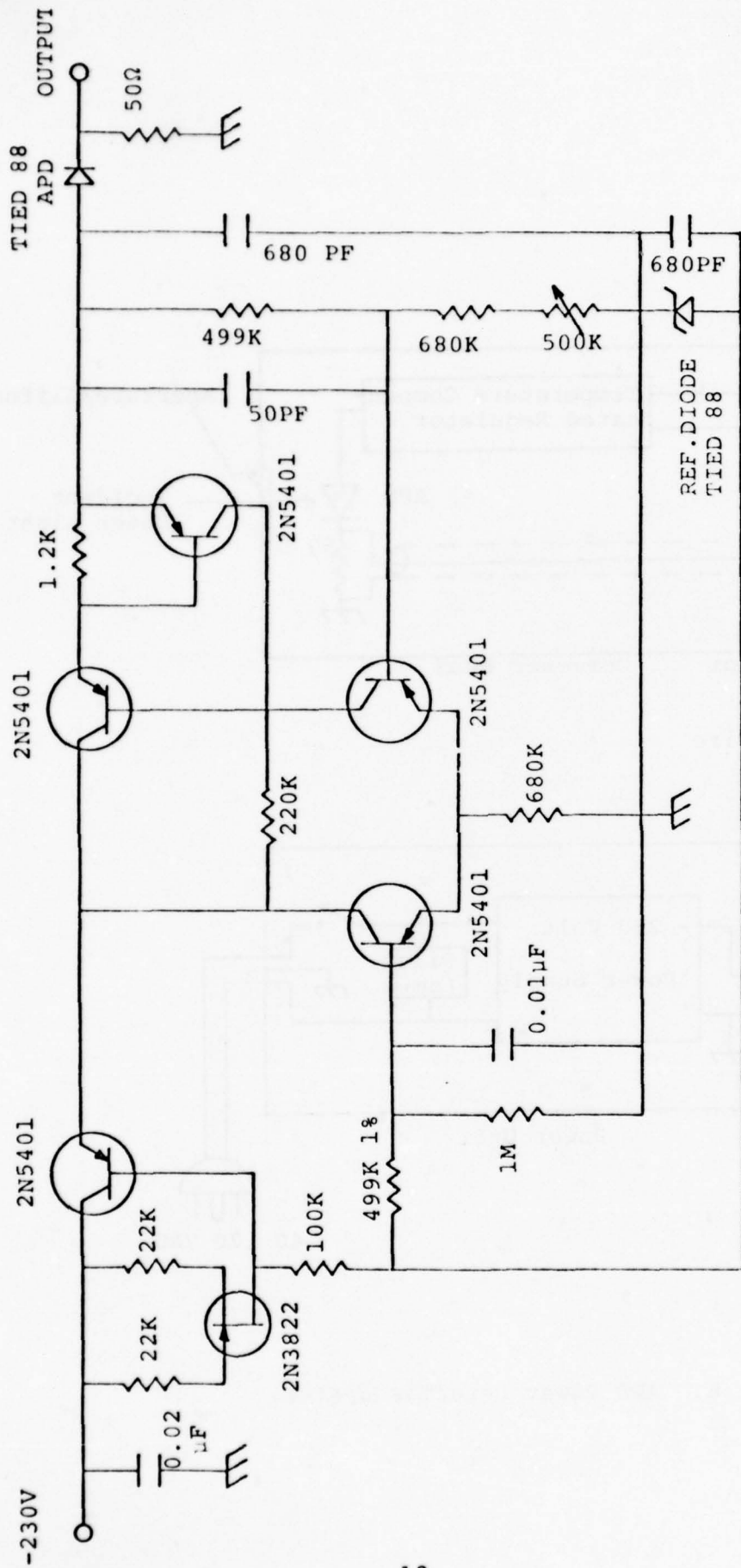

Figure 7. Avalanche Diode Regulator

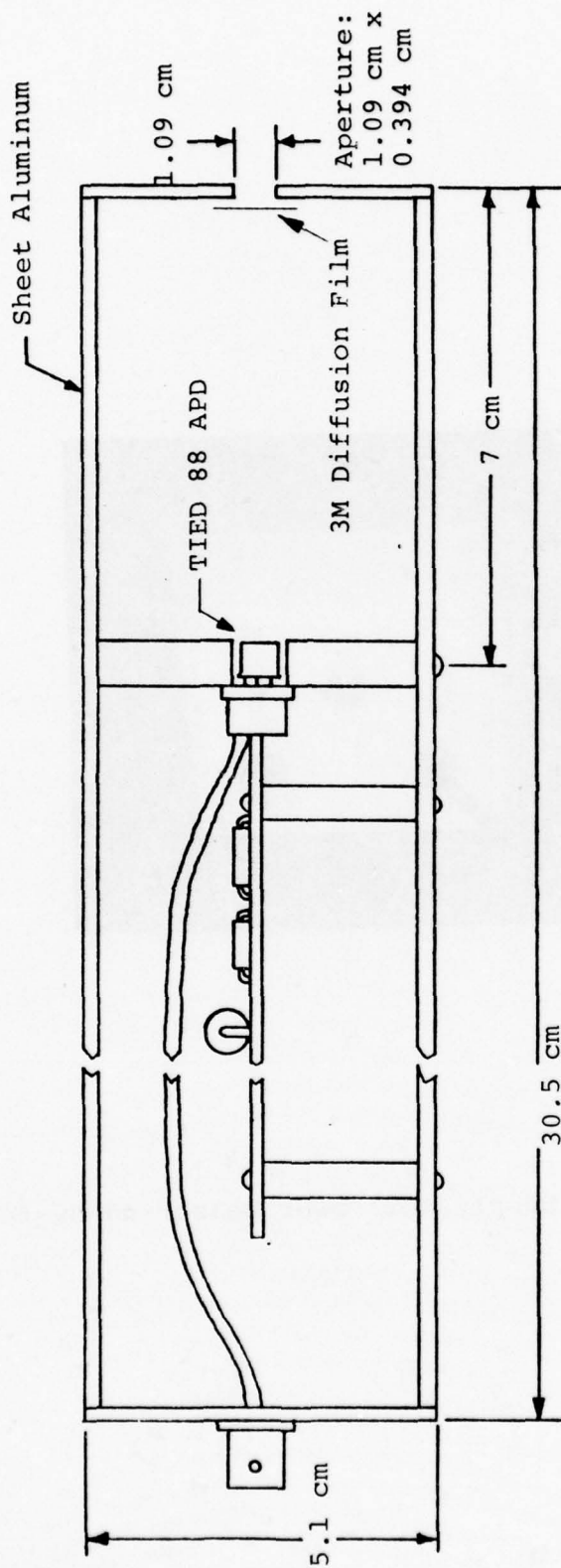

Figure 8. Internal Structure Power Detector Head.

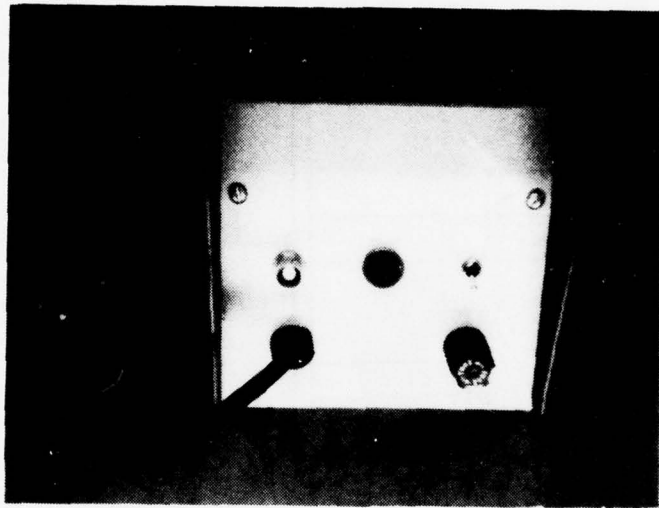

Figure 9. HV Supply for Power Measuring System.

an arbitrary distance from the diffuser. Laser light which is incident on the aperture becomes diffused into an approximately lambertian distribution such that the energy in a relatively small angle is proportional to that which is incident upon the aperture. Since the APD's active diameter is 0.762 mm and it is mounted 70 mm from the diffuser, the solid angle subtended is approximately 1.25 degrees and the approximation is much better than the overall precision of the system. The detector box is mounted to the optical rail using standard fixtures including a vertical vernier which permits accurate positioning of the detector. In use, the detector head aperture is placed 1.5 cm from the laser to be tested, the power supply is connected and turned on and the detector output is fed to one channel of the sampling oscilloscope. Since the other channel is connected to the current probe in the laser pulser and the 'scope is synchronized to the clock, the oscilloscope trace will, with appropriate calibration factors, read power output vs. drive current.

The far field ("beam pattern") apparatus (Figure 10) is also complete and ready to be used. With the 10 ns pulser (Figure 3 ) mounted atop the goniometer, taking care to locate the laser optical axis on the axis of rotation of the goniometer, the EG&G detector head is located between 65 cm and 75 cm away from the laser

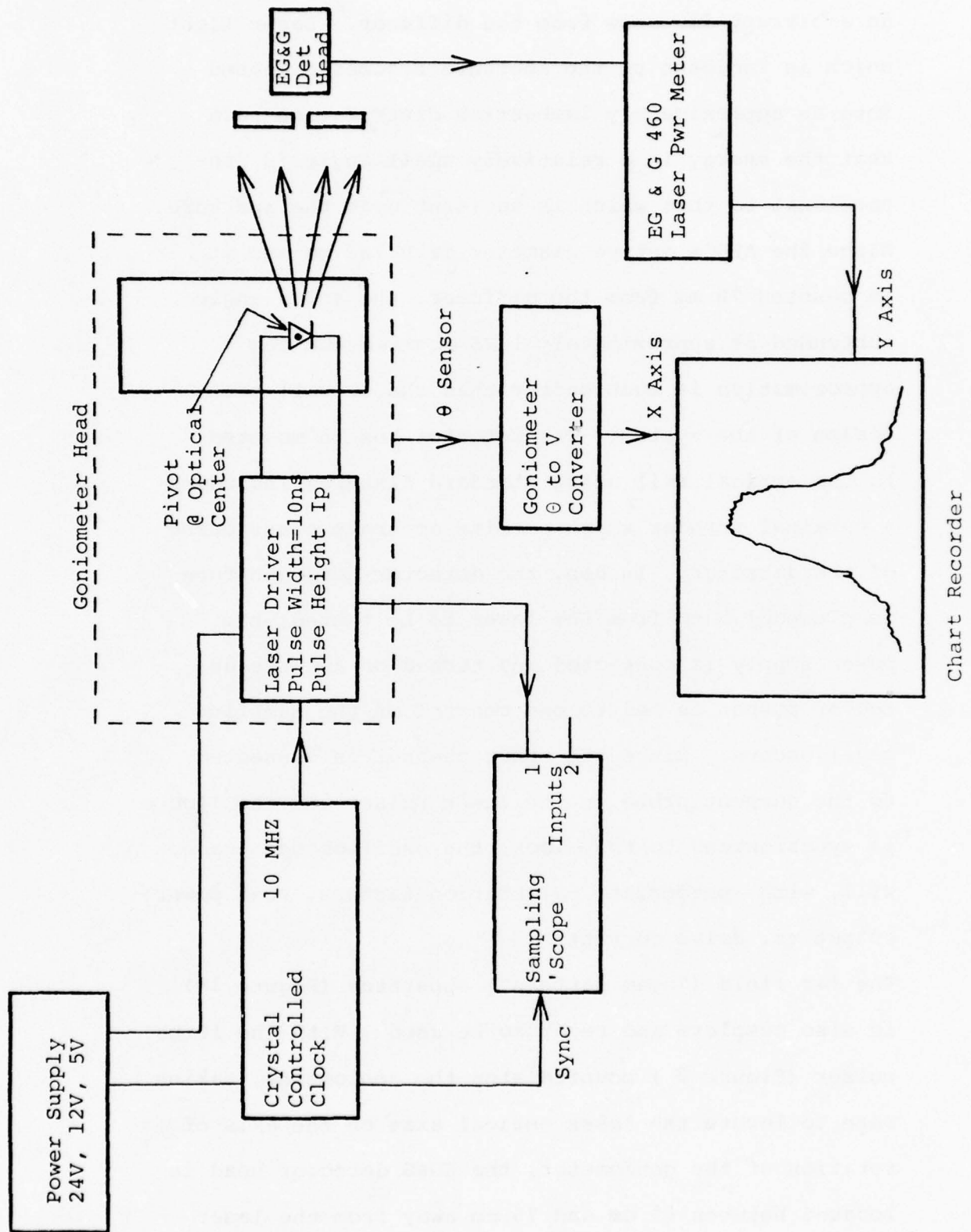

Figure 10. Measurement of Beam Width.

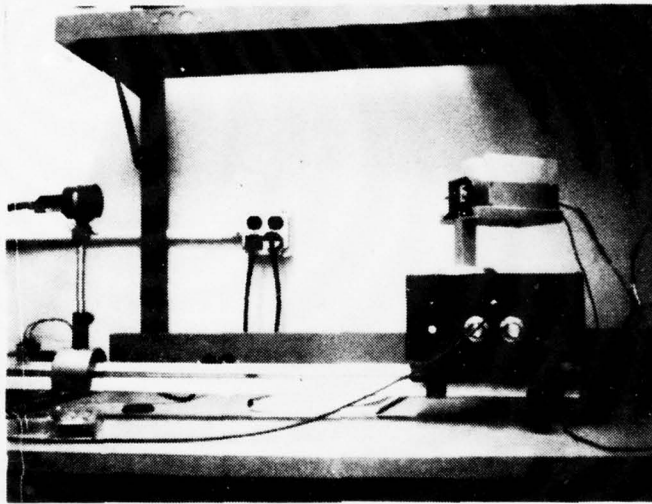

Figure 11. Photo of EG&G with Pulser on Goniometer on Rail.

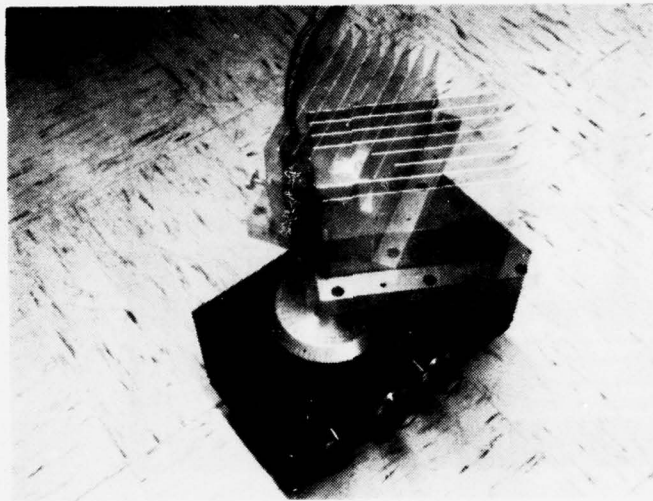

Figure 12. Double Exposure Illustrating Goniometer Operation.

(Figure 11) so that its active area subtends a solid angle of less than one degree. The output from the goniometer drives the XY recorder's X axis and the "chart recorder output" from the EG&G 460 drives the "Y" axis. Once the appropriate scale factors are set up, the head is simply rotated manually (Figure 12) to obtain the desired graph.

Preliminary investigation indicates that a CCTV approach can probably be used to measure both stripe width and uniformity. Both a video monitor and a waveform monitor would be employed to interpret the output of the CCTV camera. The laser near field image would be projected onto a screen with a metric grid. The oscilloscope would be used to insure that saturation is avoided and, via calibration with a known grey scale, permit direct stripe to stripe relative intensity measurement. The image on the video monitor can then be measured directly by comparing the image sizes of the three stripes with the grid, thereby eliminating any errors introduced by TV scan nonlinearity.

### 2.3

#### DEVICE PERFORMANCE

Thirteen lasers have entered the second half of the 2000 hour life test without incident. It is anticipated that the second engineering sample will include units from this lot.

Early in the quarter, a preliminary 168 hour burn-in



TABLE 2. TYPICAL DEVICES FROM WAFER DHA-134

<u>Unit #</u>	<u>I<sub>th</sub>, Amps</u>	<u>I<sub>max</sub>, Amps</u>	<u>λ, nm</u>
1	1.6	2.6	807
2	1.4	2.2	810
3	1.1	2.8	813
4	1.1	2.7	812
5	1.0	2.4	810
6	1.0	2.5	815
7	1.0	2.8	810
8	1.0	2.5	805
9	1.0	3.0	809
10	1.2	2.4	812
11	1.0	2.4	815

46 0700

REDFIELD ELECTRIC CO. 1000

LASER FROM WAFER  
DHA-134 @  $I_p = 2.5A$ ,  
 $P_0 = 200 \text{ mW}$

FAR FIELD PLOT  
PLANE PERPENDICULAR  
TO JUNCTION

20 DEGREES  
PER MAJOR  
DIVISION

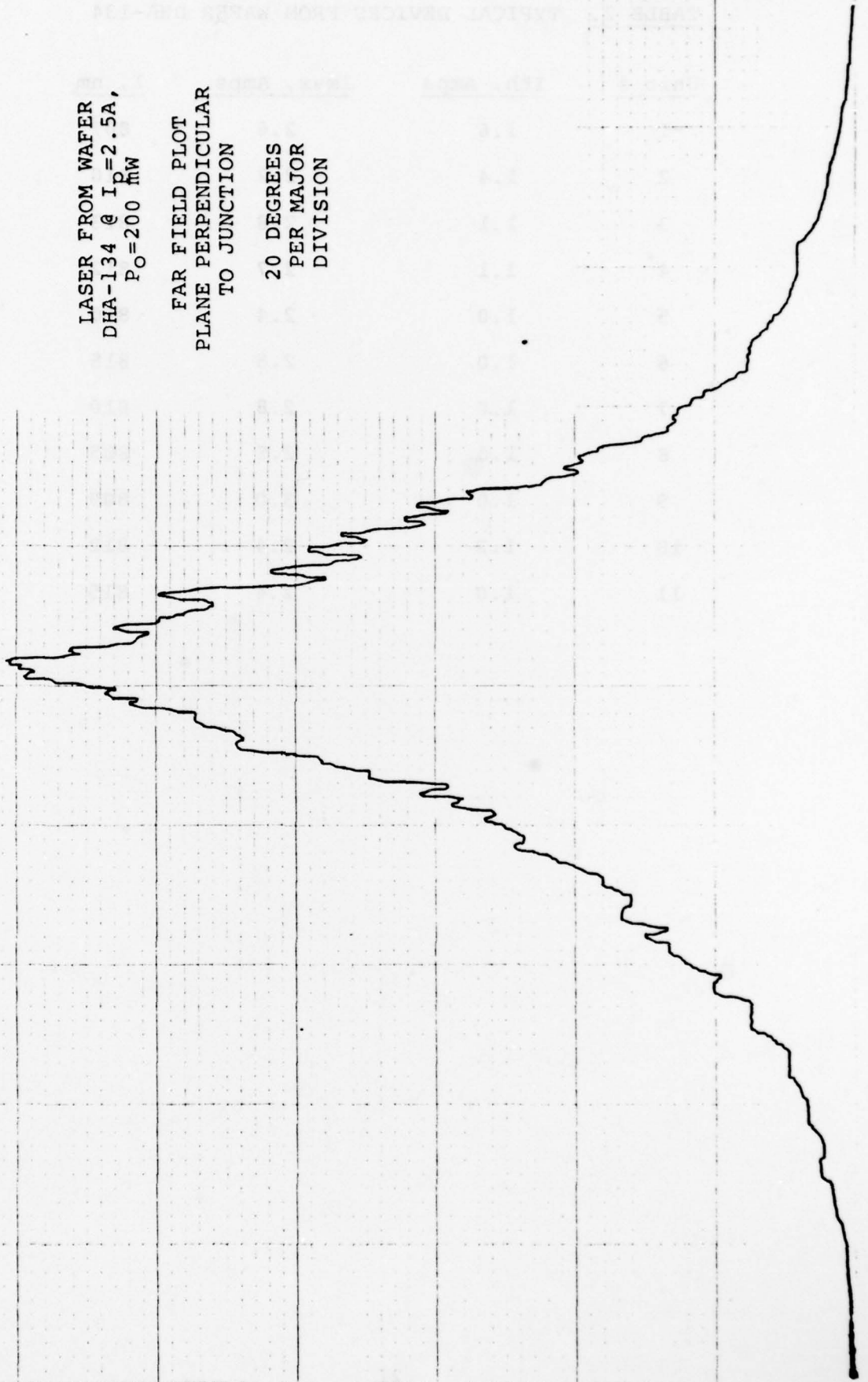

Figure 13. Laser from Wafer DHA-134.

of units was performed with emphasis directed toward selection of units for the 2000 hour life test. The 168 hour burn-in yield was about 55%, which compared favorably with the 50% yield commonly observed for other military and commercial injection laser products. From this group of devices, 16 stable lasers were selected and placed on life test to satisfy the requirements for the second engineering sample. Thirteen devices showed no significant change after 1000 hours of operation (Table 1) at 10 MHz with 10 ns pulses at  $I_p$ . Of the remaining three, two degraded below the acceptable operating range and the third was damaged by a screwdriver short to the power supply during rack adjustment.

Another wafer, DHA-134, was prepared during this period. Initial testing of devices fabricated from this wafer indicated satisfactory power output within the required drive current range. Further tests were therefore performed, with wavelength and far field test results within limits of SCS-516. These results are summarized in Table 2 and Figure 13. Many of the test setups and procedures for the test plan have been developed, while others are still in the design stages. The main work ahead principally deals with measurement of stripe width and uniformity in a manner consistent with both good accuracy and volume production.

### SECTION III

#### SUMMARY

At the close of the fifth quarter, the second engineering sample was into the second half of the 2000 hour life test, with all indications pointing to fully successful completion and delivery in the next quarter. Principal emphasis during the quarter was directed toward completion of test methods, plans, and equipment. Although much remains to be done, the areas in need of work are clear in most cases, and a steady progress toward the goals of the next quarter is expected. These goals include delivery of the 2nd engineering sample, solution of the heating problem within the burn-in rack, completion of the temperature controlled pulser for thermal impedance measurement, and further work on the test plan.

APPENDIX A

Engineering Man-Hour Utilization  
for the Fifth Quarter of the Program.

	<u>5th Qtr.</u>	<u>Cumulative</u>
T. E. Stockton	-	784 Hrs.
R. B. Gill	15 Hrs.	799 Hrs.
S. Klunk	86 Hrs.	472 Hrs.
M. Lai	178 Hrs.	178 Hrs.
F. Speer	212 Hrs.	212 Hrs.
A. Gennaro	-	371 Hrs.
A. Albano	-	590 Hrs.
Manufacturing Personnel	522 Hrs.	1650 Hrs.

APPENDIX B

DISTRIBUTION LIST

Contract DAAB07-76-C-0040

	<u>Copies</u>
Defense Documentation Center ATTN: DDC-TCA Cameron Station (Building 5) Alexandria, VA 22314	2
Director of Defense R & E ATTN: Technical Library Room 9E-1039, The Pentagon Washington, D.C. 20301	1
Defense Communications Agency ATTN: Code 340 Washington, D.C. 20305	1
Environmental Research Institute of Michigan ATTN: IRIA Library P.O. Box 8618 Ann Arbor, MI 48107	1
Director, Defense Atomic Support Agency ATTN: Technical Library Washington, D.C. 20305	1
Chief, of Naval Research ATTN: Code 427 Department of the Navy Washington, D.C. 20325	1
Naval Ships Systems Command ATTN: Code 20526 (Technical Library) Main Navy Building, Room 1528 Washington, D.C. 20360	1
Air Force Avionics Lab. ATTN: DHE (Mr. James Skalski) Wright-Patterson Air Force Base, OH 45433	1
Commander Naval Research Laboratories ATTN: Dr. A. Fenner Milton (Code 5504.2) Washington, D.C. 20375	1

DEISD-D-PC Distribution List	<u>Copies</u>
Commander Naval Electronic System Command ATTN: Mr. L. Sumney Washington, D.C. 20360	1
Commander Naval Electronics Laboratory Center ATTN: Dr. H. Wieder (Code 2600) 271 Catalina Boulevard San Diego, CA 92152	1
Commander Naval Electronics Laboratory Center ATTN: D. Williams (Code 2500) 271 Catalina Boulevard San Diego, CA 92152	1
Commander Naval Electronics Laboratory Center ATTN: D. J. Albares (Code 2600) 271 Catalina Boulevard San Diego, CA 92152	1
Commander Naval Electronics Laboratory Center ATTN: R. Leduska (Code 4400) 271 Catalina Boulevard San Diego, CA 92152	1
Commander Naval Electronics Laboratory Center ATTN: S. Miller (Code 2600) 271 Catalina Boulevard San Diego, CA 92152	1
Texas Instruments, Inc. ATTN: W. Shaunfield Box 5012 Dallas, TX 75222	1
Commander US Army Comm Res & Dev Command ATTN: DRDCO-COM-RM-1 (Dr. L. Dworkin) Fort Monmouth, NJ 07703	2
Commander US Army Comm Res & Dev Command ATTN: DRDCO-COM-ME (M. Pomerantz) Fort Monmouth, NJ 07703	1
Reliability Analysis Center RBRAC/I. L. Krulac Griffiss AFB, NY 13441	1

DELSD-D-PC

Distribution List

Copies

Air Force Armanent Lab AFATL/DLMI/Mr. Lynn Deibler Eglin AFB, FL 32542	1
US Naval Avionics Facility ATTN: Mr. Rod Katz (Code 813) 6000 E. 21st Street Indianapolis, IN 42618	1
Navy Air Systems Command ATTN: L. H. Conaway (Code 533D) Washington, D.C. 20361	1
Commander US Army Electronics Res & Dev Command ATTN: DELNV (R. Buser) Fort Monmouth, NJ 07703	1
Director Night Vision & Electro Optics Lab ATTN: DELNV-SD (Mr. S. Gibson) Fort Belvior, VA 22050	2
Division of Non-Ionizing Radiation Letterman Army Institute of Research Presidio of San Francisco San Francisco, CA 94129	1
Commander Harry Diamond Laboratory ATTN: AMSDC-RCB (Mr. R. G. Humphrey) Washington, D.C. 20438	1
Commander US Army Electronics Res & Dev Command ATTN: DELNV-L-D (V. Rosati) Fort Monmouth, NJ 07703	1
Commander US Army Materials Research Agency ATTN: AMDME-ED (Mr. Raymond L. Farrow) Watertown, MA 02172	1
Director US Army Production Equipment Agency ATTN: AMIPE-MT (Mr. C. E. McBurney) Rock Island Arsenal Rock Island, IL 61201	1

DELSD-D-PC  
Distribution List

	<u>Copies</u>
Air Force Avionics Laboratory ATTN: Mr. William Schoonover ATTN: AFAL (AVRO) Wright-Patterson Air Force Base, OH 45433	1
NASA Manned Spacecraft Center ATTN: TF4, Mr. Ray R. Glemence Houston, TX 77058	1
Naval Ships Engineer Center ATTN: Section 6171 Department of the Navy Washington, D.C. 20360	1
Dr. Fred W. Quelle Office of Naval Research 495 Summer Street Boston, Massachusetts 02210	1
Department of the Navy Naval Electronics Systems Command ATTN: Code 05143 (Mr. Carl A. Rigdon) Washington, D.C. 20360	1
Bell Telephone Laboratories, Inc. ATTN: Technical Reports Center WH2A-160 Whippany Road Whippany, N.J. 07981	1
Kenneth R. Hutchinson AFAL/DHO-2 Wright-Patterson Air Force Base, OH 45433	1
Commander AFML/LTE ATTN: Capt George Boyd Wright-Patterson Air Force Base, OH 45433	1
Commander Hq, AFSC/DLCAA ATTN: Major D. C. Luke Andrews Air Force Base Washington, D. C. 20331	1
Commander Air Force Weapons Lab (AFWL/ELP) ATTN: CPT. J. Tucker Kirtland Air Force Base, NM 87117	1

DELS-D-PC

Distribution List

Copies

Commander 1  
US Army Missile Command  
ATTN: AMSMI-ILS (Mr. W. Tharp)  
Building 4488  
Redstone Arsenal, AL 35809

Naval Weapons Center 1  
Code 3353  
ATTN: Mr. R. Swenson  
China Lake, CA 93555

Director 1  
National Security Agency  
ATTN: R-4, Mr. P. S. Szozepek  
Fort George G. Meade, MD 20755

Advisory Group on Electron Devices 1  
ATTN: Secretary, SPGR on Optical Masers  
201 Varick Street  
New York, NY 10014

Institute Defense Analysis 1  
ATTN: Mr. Lucien M. Biberman  
400 Army - Navy Drive  
Arlington, VA 22202

Commander 3  
US Army Electronics Res & Dev Command  
ATTN: DELSD-D-PC (Mr. J. Sanders)  
Fort Monmouth, NJ 07703

Harry Diamond Lab 1  
ATTN: J. Blackburn  
2800 Powder Mill Rd  
Adelphia, MD 20783

Commander, RADAC 1  
ATTN: EMEDA (Mr. M. Kesselman)  
Griffis Air Force Base, NY 13440

DELSD-D-PC  
Distribution List

	<u>Copies</u>
Air Force Materials Laboratory ATTN: AMSL (LTE) Mrs. Tarrants Wright-Patterson Air Force Base, Ohio 45433	1
Commander US Naval Ordnance Laboratory ATTN: Technical Library White Oak, Silver Spring, MD 20910	1
Rome Air Development Center (EMTLD) ATTN: Documents Library Ghiffiss Air Force Base, N.Y. 13440	1
Electronic Systems Division (ESTI) L. G. Hanscom Field Bedford, Massachusetts 01730	1
Air Force Weapons Laboratory ATTN: WLIL Kirtland Air Force Base, New Mexico 07117	1
OFC, Assistant Secretary of the Army (R&D) ATTN: Assistant for Research Room 3-E-379, The Pentagon Washington, D. C. 20310	1
Chief of Research and Development Department of the Army ATTN: Mr. R. B. Watson Army Research Office Washington, D. C. 20310	1
Commander US Army Materiel Development & Readiness Command ATTN: DRCMT 5001 Eisenhower Avenue Alexandria, VA 22333	1
RCA Electronic Components ATTN: Mr. N. R. Hangen New Holland Avenue Lancaster, PA 17604	1
ITT Electro-Optical Products Division Box 7065 Roanoke, VA 24019 ATTN: R. Williams	1
Spectronics Inc. 830 E. Arapalo Road Richardson, TX 78080 ATTN: W. Kolander	1

DELSO-D-PC  
Distribution List

	<u>Copies</u>
Bell Northern Research Ltd P. O. Box 3511 Station C Ottawa, Canada K1Y4H7 ATTN: B. C. Kirk	1
RCA Laboratories Princeton, N.J. 08540 ATTN: Henry Kressel	1
Hughes Aircraft Company ATTN: Company Technical Document Center 6/E110 Centinela at Teale Culver City, CA 90230	1
Hewlett Packard Laboratories 1501 Page Mill Road Palo Alto, CA 94304 ATTN: Mr. George Kaposhilih	1
Hughes Research Laboratories ATTN: M. Barnaski 3011 Malibu Canyon Road Malibu, CA 90265	1
Bell Telephone Laboratories ATTN: Dr. T. Winternitz Military Design Support Laboratory Whippany, N.J. 07981	1
Corning Glass Work ATTN: Dr. Roy Love Corning, N.Y. 14830	1
Harris Industries Electro-Optics Operation ATTN: John Williams, Sales Mgr P.O. Box 37, Melbourne, FL 32901	1
Varo Texas Division ATTN: R. Laughlin 2201 W. Walnut St. P.O. Box 401267 Garland, TX 75040	1
Commander US Army Communication & Electronics Material Readiness Command ATTN: DRSEL-LE-3C (Mr. J. Inserra) Fort Monmouth, NJ 07703	1

