

AD-A072 613

LEHIGH UNIV BETHLEHEM PA INST OF FRACTURE AND SOLID --ETC F/G 11/4
TRANSIENT HYDROTHERMAL STRESSES IN COMPOSITES: COUPLING OF MOIS--ETC(U)
MAR 79 G C SIH, M T SHIH

UNCLASSIFIED

AMMRC-TR-79-14

NL

| OF |
AD
A072613

11

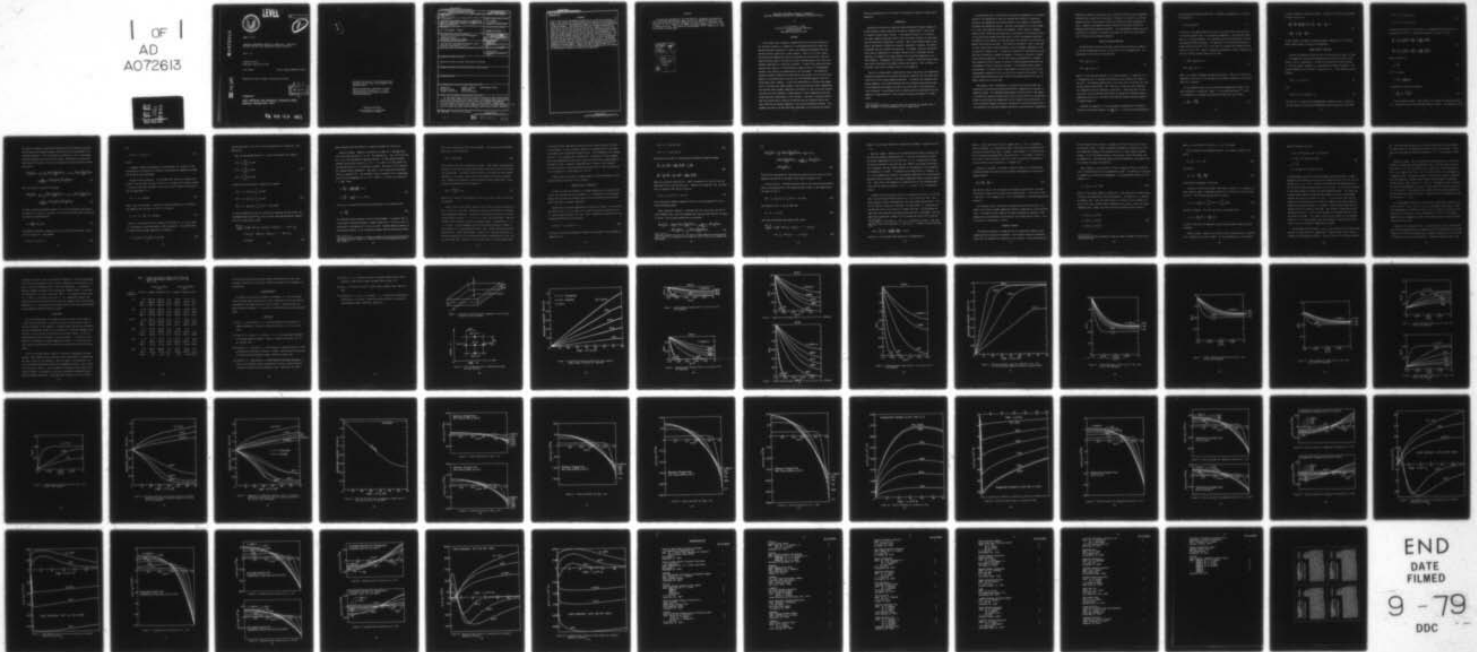

END
DATE
FILMED
9 - 79
DDC

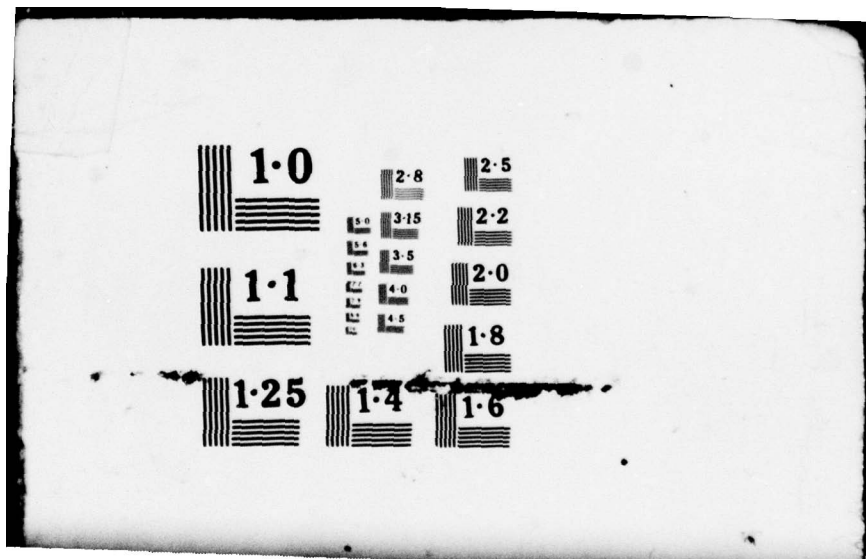

1.0

2.8

2.5

3.15

2.2

1.1

3.5

2.0

4.0

4.5

1.8

1.25

1.4

1.6

LEVEL II

AD



AD A 072613

AMMRC TR 79-14

TRANSIENT HYDROTHERMAL STRESSES IN COMPOSITES: COUPLING OF
MOISTURE AND HEAT WITH TEMPERATURE VARYING DIFFUSIVITY

March 1979

Lehigh University
Bethlehem, Pennsylvania 18015

Final Report

Contract Number DAAG46-78-C-0014

Approved for public release; distribution unlimited

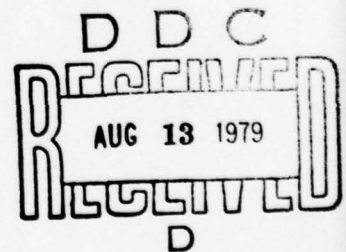

DDC FILE COPY

Prepared for

ARMY MATERIALS AND MECHANICS RESEARCH CENTER
Watertown, Massachusetts 02172

79 08 -09 061



LEVEL



VDV055013

The findings in this report are not to be construed as an official Department of the Army position, unless so designated by other authorized documents.

Mention of any trade names or manufacturers in this report shall not be construed as advertising nor as an official indorsement or approval of such products or companies by the United States Government.

DISPOSITION INSTRUCTIONS

Destroy this report when it is no longer needed.
Do not return it to the originator.

39 08 03 001

UNCLASSIFIED

SECURITY CLASSIFICATION OF THIS PAGE (When Data Entered)

REPORT DOCUMENTATION PAGE		READ INSTRUCTIONS BEFORE COMPLETING FORM
1. REPORT NUMBER 18 AMMRC/TR-79-14	2. GOVT ACCESSION NO.	3. RECIPIENT'S CATALOG NUMBER 9
4. TITLE (and Subtitle) 6 TRANSIENT HYDROTHERMAL STRESSES IN COMPOSITES: COUPLING OF MOISTURE AND HEAT WITH TEMPERATURE VARYING DIFFUSIVITY		5. TYPE OF REPORT & PERIOD COVERED Final Report
7. AUTHOR(s) 10 G. C./Sih and M. T./Shih		6. PERFORMING ORG. REPORT NUMBER
8. CONTRACT OR GRANT NUMBER(s) 15 DAAG46-78-C-0014		9. PERFORMING ORGANIZATION NAME AND ADDRESS Institute of Fracture and Solid Mechanics Lehigh University Bethlehem, Pennsylvania 18015
10. PROGRAM ELEMENT PROJECT, TASK AREA & WORK UNIT NUMBERS D/A Project 16 8X363304D215 AMCMS Code: 633304.21500.03 Agency Accession:		11. CONTROLLING OFFICE NAME AND ADDRESS Army Materials and Mechanics Research Center Watertown, Massachusetts 02172
12. REPORT DATE 19 March 1979		13. NUMBER OF PAGES 66 1267p
14. MONITORING AGENCY NAME & ADDRESS (if different from Controlling Office)		15. SECURITY CLASS. (of this report) Unclassified
15a. DECLASSIFICATION/DOWNGRADING SCHEDULE n/a		16. DISTRIBUTION STATEMENT (of this Report) Approved for public release; distribution unlimited.
17. DISTRIBUTION STATEMENT (of the abstract entered in Block 20, if different from Report)		
18. SUPPLEMENTARY NOTES		
19. KEY WORDS (Continue on reverse side if necessary and identify by block number) Composites Thermal stresses Hydrothermal effect Moisture content Temperature Thermal diffusivity Finite difference		
20. ABSTRACT (Continue on reverse side if necessary and identify by block number) In this paper, the influence of coupled diffusion of heat and moisture on the transient stresses in a composite is investigated analytically where the moisture diffusion coefficient is taken to be temperature dependent while the thermal diffusion coefficient is kept constant. There is no a priori reason why moisture and temperature should be uncoupled such that each will obey the simple diffusion theory, particularly without reference		

DD FORM 1 JAN 73 1473 EDITION OF 1 NOV 65 IS OBSOLETE

UNCLASSIFIED

SECURITY CLASSIFICATION OF THIS PAGE (When Data Entered)

407 099

39 08 09 061

UNCLASSIFIED

SECURITY CLASSIFICATION OF THIS PAGE(When Data Entered)

Block No. 20

ABSTRACT

made to the initial and boundary conditions of a particular situation. A study of the coupled diffusion equations were made by a finite-difference scheme allowing for time-dependent changes in the humidity and temperature of the environment. The appropriate transient boundary conditions are specified on the surfaces of an infinite plate. Numerical calculations were carried out for the T300/5208 graphite fiber-reinforced epoxy matrix composite in which the nonuniformity of moisture and temperature is evaluated for sudden changes in the surface moisture and/or temperature. The coupling effect between temperature and moisture is found to be most significant when the plate undergoes a sudden change in surface temperature while the surface moisture concentration is held constant. The present findings indicate that the stresses due to coupling can deviate from the uncoupled results anywhere from 20 to 80 percent depending on the surface temperature gradient. This suggests the need to perform additional experiments for evaluating the coupled diffusion phenomenon and its influence on the mechanical behavior of epoxy-resin-composites.

UNCLASSIFIED

SECURITY CLASSIFICATION OF THIS PAGE(When Data Entered)

Foreword

This work was performed for the Army Materials and Mechanics Research Center at Watertown, Massachusetts under Contract No. DAAG46-78-C-0014 with the Institute of Fracture and Solid Mechanics, Lehigh University, Bethlehem, Pennsylvania. Mr. J. F. Dignam of the AMMRC was project manager and Dr. S. C. Chou as technical monitor. The support and encouragement of Mr. Dignam and Dr. Chou are gratefully acknowledged.

Accession For	
NTIS GRA&I	<input checked="" type="checkbox"/>
DDC TAB	<input type="checkbox"/>
Unannounced	<input type="checkbox"/>
Justification	<input type="checkbox"/>
By _____	
Distribution/	
Availability Codes	
Dist.	Avail and/or special
A	

TRANSIENT HYDROTHERMAL STRESSES IN COMPOSITES:
COUPLING OF MOISTURE AND HEAT WITH TEMPERATURE VARYING DIFFUSIVITY

by

G. C. Sih and M. T. Shih
Institute of Fracture and Solid Mechanics
Lehigh University
Bethlehem, Pennsylvania 18015

ABSTRACT

In this paper, the influence of coupled diffusion of heat and moisture on the transient stresses in a composite is investigated analytically where the moisture diffusion coefficient is taken to be temperature dependent while the thermal diffusion coefficient is kept constant. There is no a priori reason why moisture and temperature should be uncoupled such that each will obey the simple diffusion theory, particularly without reference made to the initial and boundary conditions of a particular situation. A study of the coupled diffusion equations were made by a finite-difference scheme allowing for time-dependent changes in the humidity and temperature of the environment. The appropriate transient boundary conditions are specified on the surfaces of an infinite plate. Numerical calculations were carried out for the T300/5208 graphite fiber-reinforced epoxy matrix composite in which the nonuniformity of moisture and temperature is evaluated for sudden changes in the surface moisture and/or temperature. The coupling effect between temperature and moisture is found to be most significant when the plate undergoes a sudden change in surface temperature while the surface moisture concentration is held constant. The present findings indicate that the stresses due to coupling can deviate from the uncoupled results anywhere from 20 to 80 percent depending on the surface temperature gradient. This suggests the need to perform additional experiments for evaluating the coupled

diffusion phenomenon and its influence on the mechanical behavior of epoxy-resin-composites.

INTRODUCTION

Absorption of moisture by composites causes dimensional changes through non-uniform expansion and/or contraction of material elements which in turn leads to internal stresses and/or strains. If the physical process is of a more active type, caused by capillary flow of fluid into voids, stresses can occur even when the macroscopic deformation is uniform. These fluid-induced stresses could explain the lowered stiffness and strength of composites. Moreover, the thermal environment may also interact with moisture. For example, voids and microscopic cracks open as temperature is increased, and more fluid is absorbed into the openings; the trapped fluid causes growth of the flaws when temperature is reduced suddenly. Subsequently, the material is capable of absorbing more moisture more quickly than before the thermal gradient were applied. Such a process, if continued, could lead to eventual failure of the composite.

There is an urgent need to quantitatively assess the moisture and temperature interaction effects which can affect the physical properties [1] and stress characteristics [2,3] of epoxy-composite materials. At present, the composite technology community is very much concerned with this problem because more and more of the composites with epoxy-resin matrix are being used for constructing aircraft structures. No confidence level in design could be established unless the behavior of these materials in the presence of adverse environments* is understood.

*The influence of chemical reaction, which may also play an important role in many instances, will not be addressed in this communication.

As mentioned earlier, the diffusion of moisture and temperature is intimately related to the degradation of both the strength and stiffness of composites. Increasing the temperature and moisture content in the composite can generally accelerate the degradation process. Previous investigations [1,2] have assumed as a priori that these two effects are uncoupled. Such a decision, however, cannot be made intuitively but should rely on an analysis of the coupling theory for the particular problem involving specific initial and boundary conditions. Information on this subject is to say the least very lacking at this time and no general conclusion can be given. The significant variables in such a study must at least involve time, relative humidity of the environment, temperature, relevant physical constants, etc. The realistic prediction of the moisture and temperature distribution in composites depends, of course, on selecting the appropriate governing equations. To this end, various phenomenological arguments were presented in [4] to explore a variety of coupled equations describing the simultaneous diffusion of moisture and heat. Five different physical models were obtained. The coefficients in these models are associated with the basic thermodynamic properties of the solid and can be related to one another. This was made possible because the basic form of the coupled equations for the five models turned out to be the same.

The purpose of this investigation is to develop an analytical model and technique for calculating the nonuniform moisture, temperature and stresses in composite systems. The T300/5208 graphite/epoxy system was used in the numerical calculation, because diffusion data as well as the variation of the moisture diffusion coefficient with temperature for this material are available [5]. A finite difference computer program was developed for solving the coupled diffusion equations with transient boundary conditions on moisture and/or temperature.

Examples and numerical calculations are provided for moisture and/or temperature diffusing into a plate from its surfaces. The plate is initially at a uniform temperature with a given moisture content distributed uniformly throughout the plate. Suddenly, the temperature and/or moisture at the plate surfaces are changed and maintained constant thereafter. The corresponding stresses are also calculated as a function of time while the numerical results for other quantities of interest are displayed graphically.

COUPLED DIFFUSION EQUATIONS

The derivation of the basic equations coupling heat and moisture content in a solid has already been discussed in [4] and will not be repeated here. The second model in [4] refers to the equations

$$\begin{aligned} D\nabla^2 C - \frac{\partial}{\partial t} (C - \lambda T) &= 0 \\ D\nabla^2 T - \frac{\partial}{\partial t} (T - \nu C) &= 0 \end{aligned} \tag{1}$$

where ∇^2 is the Laplacian operator in the space variables. In equations (1), T is temperature and C is the mass of moisture per unit volume of void space in the solid. The diffusion coefficients D and D have units of area per unit time, and the coupling coefficients λ and ν have units of mass per unit volume per unit temperature and the reciprocal, respectively. These equations are relatively easy to solve when the coefficients are constant and boundary values of temperature and moisture content are held constant between occasional moments of sudden changes [3].

Solutions of equations (1) can be examined to determine the influence of coupling on the overall behavior of composites. It has been noted experimentally

that the moisture diffusion coefficient, D , depends on temperature by a relation of the form [6]

$$D = D_0 \exp(-E_0/RT) \quad (2)$$

in which E_0 is the energy required for one unit of mass to move into the solid, R is the gas constant, and T is the absolute temperature. The diffusion coefficient, D , is usually measured in an experiment such as that described in [1] for the uncoupled diffusion equation. The meaning of D is altered when coupling is present and the values of D in [1] can differ by an amount which depends on the values of D and λv [7]. When D is temperature dependent as shown in equation (2), then the following coupled theory must be used:

$$\nabla \cdot (D\nabla C) - \frac{\partial}{\partial t} (C - \lambda T) = 0 \quad (3)$$

$$D\nabla^2 T - \frac{\partial}{\partial t} (T - vC) = 0$$

where D is constant throughout the present discussion. When D is a function of temperature, equations (3) are nonlinear and a numerical scheme for solving equations (3) is required.

For the problem at hand, only the moisture and temperature changes in the plate thickness or z -direction, Figure 1, is considered and hence $\nabla^2 = \partial^2/\partial z^2$. It is expedient to introduce the dimensionless space and time variables

$$\xi = \frac{2z}{h}, \quad \theta = \frac{4D_0 t}{h^2} \quad (4)$$

in which h stands for the plate thickness. Equations (3) can thus be expressed in terms of ξ and θ as

$$\left[\frac{\partial^2 C}{\partial \xi^2} + \frac{E_0}{RT^2} \left(\frac{\partial C}{\partial \xi} \right) \left(\frac{\partial T}{\partial \xi} \right) \right] \exp\left(-\frac{E_0}{RT}\right) - \left(\frac{\partial C}{\partial \theta} - \lambda \frac{\partial T}{\partial \theta} \right) = 0 \quad (5)$$

$$D \frac{\partial^2 T}{\partial \xi^2} - D_0 \left(\frac{\partial T}{\partial \theta} - \nu \frac{\partial C}{\partial \theta} \right) = 0$$

In what follows, two types of transient boundary conditions will be treated, namely sudden change in moisture and temperature.

SUDDEN CHANGE IN MOISTURE

Consider the problem of diffusion into an infinite plate as shown in Figure 1. The temperature and moisture concentration are initially uniform at the values T_i and C_i , respectively. At time $t=0$, the moisture at both surfaces $z = \pm h/2$ are suddenly changed to C_f , and maintained constant thereafter. The surface temperature of the plate is always kept at T_i . These conditions may be stated as

$$T(z,0) = T_i, \quad C(z,0) = C_i \quad (6)$$

and

$$T(\pm h/2,t) = T_i, \quad C(\pm h/2,t) = C_f \quad (7)$$

for time $t>0$. In terms of the nondimensional variables ξ and θ in equations (4), the solution for moisture and temperature may be expressed in the forms

$$C(t) = C_i + (C_f - C_i) f(\xi, \theta) \quad (8)$$

$$T(t) = T_i + v(C_f - C_i) g(\xi, \theta)$$

in which $f(\xi, \theta)$ and $g(\xi, \theta)$ are functions to be determined from the conditions in equations (6) and (7). Substituting equations (8) into (5) yields

$$\frac{\partial f}{\partial \theta} = \frac{1}{1-\lambda v} \left\{ \frac{\lambda v}{u_0} \frac{\partial^2 g}{\partial \xi^2} + F \left[\frac{\partial^2 f}{\partial \xi^2} + \frac{AB}{(1+Bg)^2} \frac{\partial f}{\partial \xi} \frac{\partial g}{\partial \xi} \right] \right\} \quad (9)$$

$$\frac{\partial g}{\partial \theta} = \frac{1}{1-\lambda v} \left\{ \frac{1}{u_0} \frac{\partial^2 g}{\partial \xi^2} + F \left[\frac{\partial^2 f}{\partial \xi^2} + \frac{AB}{(1+Bg)^2} \frac{\partial f}{\partial \xi} \frac{\partial g}{\partial \xi} \right] \right\}$$

where u_0 stands for

$$u_0 = \frac{D_0}{D} \quad (10)$$

and F is given by

$$F = \exp \left[- \frac{A}{1+Bg(\xi, \theta)} \right] \quad (11)$$

The quantities A and B are defined as

$$A = \frac{E_0}{RT_i}, \quad B = \frac{v(C_f - C_i)}{T_i} \quad (12)$$

Finite difference method. Since equations (9) cannot be solved analytically, it is necessary to resort to approximate numerical methods. The method of finite

difference is adopted to replace the governing partial differential equations and the associated transient boundary conditions by the corresponding finite-difference equations. This then reduces the problem to a set of simultaneous algebraic equations which can be easily solved. Referring to the space and time interval in Figure 2, the first of equations (9) may be written in difference form as

$$\begin{aligned} \frac{f_{m,n+1} - f_{m,n}}{\Delta\theta} = & \frac{1}{1-\lambda\nu} \left\{ \frac{\lambda\nu}{u_0} \left(\frac{g_{m+1,n} - 2g_{m,n} + g_{m-1,n}}{(\Delta\xi)^2} \right) + F(m,n) \left[\frac{f_{m+1,n} - 2f_{m,n} + f_{m-1,n}}{(\Delta\xi)^2} \right] \right. \\ & \left. + \frac{AB}{(1+Bg_{m,n})^2} \left(\frac{f_{m+1,n} - f_{m,n}}{\Delta\xi} \right) \left(\frac{g_{m+1,n} - g_{m,n}}{\Delta\xi} \right) \right\} \end{aligned} \quad (13)$$

while the second of equations (9) becomes

$$\begin{aligned} \frac{g_{m,n+1} - g_{m,n}}{\Delta\theta} = & \frac{1}{1-\lambda\nu} \left\{ \frac{1}{u_0} \left(\frac{g_{m+1,n} - 2g_{m,n} + g_{m-1,n}}{(\Delta\xi)^2} \right) + F(m,n) \left[\frac{f_{m+1,n} - 2f_{m,n} + f_{m-1,n}}{(\Delta\xi)^2} \right] \right. \\ & \left. + \frac{AB}{(1+Bg_{m,n})^2} \left(\frac{f_{m+1,n} - f_{m,n}}{\Delta\xi} \right) \left(\frac{g_{m+1,n} - g_{m,n}}{\Delta\xi} \right) \right\} \end{aligned} \quad (14)$$

In order to achieve acceptable accuracy in the finite difference calculations, the grid size in space, Δz , and time, Δt , must be sufficiently small and satisfy the stability requirement that

$$\Delta t \leq \frac{(\Delta z)^2}{4D_0} \exp(E_0/RT) \quad (15)$$

The boundary conditions in equations (6) and (7) may then be written in terms of $f(\xi, \theta)$ and $g(\xi, \theta)$. They become

$$f(\xi, 0) = 0, \quad g(\xi, 0) = 0 \quad (16)$$

and

$$f(\pm 1, \theta) = 1, g(\pm 1, \theta) = 0 \quad (17)$$

for $\theta > 0$.

A computer program was developed to solve equations (13) through (17) for the functions $f(\xi, \theta)$ and $g(\xi, \theta)$ from which the moisture and temperature throughout the solid can be determined.

Average moisture quantities. In this model [4], the mass of moisture contained in the solid per unit mass of solid, M , is assumed to be linearly related to the mass of moisture contained in the voids per unit volume of void space, C , and the temperature, i.e.,

$$M = \sigma C - \omega T + \text{constant} \quad (18)$$

where σ and ω are constants. The mass of moisture contained in the volume of the composite per unit mass of solid, m , is given by

$$m = \frac{v}{\rho} C + M = \omega \left[\frac{C}{\lambda} - T \right] + \text{constant} \quad (19)$$

in which v is the fraction of unit volume of the voids and ρ is $(1-v)\rho_s$ where ρ_s is the density of the solid when no voids are present. The average values of these moisture content quantities are defined as

$$\bar{C} = \frac{1}{V} \int_V C dV, \bar{M} = \frac{1}{V} \int_V M dV, \bar{m} = \frac{1}{V} \int_V m dV \quad (20)$$

The total moisture in the voids, solid and composite are, respectively, $v\bar{C}$, $\rho V\bar{M}$ and $\rho V\bar{m}$.

Now, let the average values of T , C and m be defined by the integrals

$$\begin{aligned}\bar{T}(t) &= \frac{1}{h} \int_{-h/2}^{h/2} T(z,t) dz \\ \bar{C}(t) &= \frac{1}{h} \int_{-h/2}^{h/2} C(z,t) dz \\ \bar{m}(t) &= \frac{1}{h} \int_{-h/2}^{h/2} m(z,t) dz\end{aligned}\tag{21}$$

In terms of $f(\xi, \theta)$ and $g(\xi, \theta)$, equations (21) become

$$\begin{aligned}\bar{T}(t) - T_i &= \frac{\nu}{2} (C_f - C_i) \int_{-1}^1 g(\xi, \theta) d\xi \\ \bar{C}(t) - C_i &= \frac{1}{2} (C_f - C_i) \int_{-1}^1 f(\xi, \theta) d\xi \\ \bar{m}(t) - m_i &= \frac{\omega}{2\lambda} (C_f - C_i) \int_{-1}^1 [f(\xi, \theta) - \lambda \nu g(\xi, \theta)] d\xi\end{aligned}\tag{22}$$

In view of equations (6) and (7), the third of equations (22) may be put into the dimensionless form $(\bar{m}(t) - m_i) / (m_f - m_i)$ which, when approximated by Simpson's rule for a fixed time θ_0 , gives

$$\begin{aligned}\frac{\bar{m}(t) - m_i}{m_f - m_i} &= \frac{1}{2} \left(\frac{\Delta\xi}{3}\right) \{ [f(1, \theta_0) + 4f(2, \theta_0) + 2f(3, \theta_0) + \dots + 4f(n-1, \theta_0) \\ &\quad + f(n, \theta_0)] - \lambda \nu [g(1, \theta_0) + 4g(2, \theta_0) + \dots + 4g(n-1, \theta_0) \\ &\quad + g(n, \theta_0)] \}\end{aligned}\tag{23}$$

Having completed the preliminaries, a numerical example will now follow.

Numerical example. Numerical calculations are made for a T300/5208 epoxy resin plate with thickness $h = 0.2$ cm. The constants $D_0 = 1.53 \times 10^3$ cm²/hr and $E_0 = 1.25 \times 10^4$ cal/g·mole are obtained from [5]. For the coupled diffusion problem, the particular values of $u = 0.1$, $\lambda = 0.5$ and $\nu = 0.5$ are chosen* for the calculation while ω is an arbitrary constant. The choice of this selection will become evident subsequently. Note that $u = D/\mathcal{D}$, should be distinguished from u_0 in equation (10). The constants A and B in equation (12) is determined from an initial temperature of $T_i = 21^\circ\text{C} = 294^\circ\text{K}$, $C_i = 0$ and a gas constant of $R = 1.986$. Hence

$$A = \frac{E_0}{RT_i} = \frac{1.25 \times 10^4}{1.986 (294)} = 21.4 \quad (24)$$

$$B = \frac{\nu C_f}{T_i} = \frac{C_f}{294} = 1.7 \times 10^{-3} C_f$$

in which C_f , the equilibrium moisture concentration, can be obtained from

$$C_f = \frac{\rho \gamma_s}{1 + \gamma_s} \quad (25)$$

for different relative humidity or RH of the environment. In equation (25), γ_s is the specific humidity measured in grams of water per lb of dry air and ρ is the density of the ambient air in units of g/cm³. Another important quantity in the diffusion analysis is the relationship between equilibrium moisture content

*The choice of this selection is based on comparing the analytical prediction of the percent moisture content as a function of \sqrt{t} with the experimental data in [5], Figure 3.

$\bar{m}(\infty)$ of the composite and RH of the environment. For the post-cured T300/5208 epoxy resin, the relation [5]

$$\bar{m}(\infty) = 0.0155 \text{ (RH)} \quad (26)$$

may be used in which RH is expressed in percent. There remains the appropriate selection of the time and space interval before carrying out the finite difference calculations. The plate in the z-direction is divided into seven segments and hence $\Delta z = h/7$ while Δt must satisfy the stability condition in equation (15). Results are expressed in terms of percent moisture content $\bar{m}(t)$ as manifested by the weight gain of the composite:

$$\bar{m}(t) = \frac{w(t) - w_i}{w_i} \times 100 \quad (27)$$

where $w(t)$ is weight of the specimen at time t and w_i the initial dry weight of the specimen.

Figure 3 gives a plot of $\bar{m}(t)$ versus \sqrt{t} for different relative humidities of RH = 13, 33, 52, 75 and 100%. The moisture diffusion coefficient D is assumed to be temperature dependent. The dotted curves represent solutions for the uncoupled theory in which $\lambda = \omega = \beta = 0$, $\lambda\nu = 0$ and u can be arbitrary. They differ very little from the curves for the coupled theory. The values of $u = 0.1$, $\lambda = 0.5$ and $\nu = 0.5$ are selected such that the coupled solutions in Figure 3 give the best fit to the experimental data in [5]. Similar results can also be obtained for $T_i = 43^\circ\text{C}$, 63°C and 82°C . Figures 4 to 8 show the variations of moisture content $\bar{m}(t)$ with the normalized thickness coordinate $2z/h$ for RH = 13, 33, 52, 75 and 100%. Initially, i.e., for small time t , only the region close

to the plate surface experiences moisture while the center region of the plate is not affected. As time increases, moisture is penetrated into all the material elements with the minimum influence at $z=0$. The difference of $\bar{m}(t)$ between $z=0$ and $z = \pm h/2$ increases with increasing RH. The effect of initial temperature on the penetration of moisture is shown in Figure 9 for a sudden change of RH from 0% to 100%. Coupling is neglected and D is taken to be a constant. The time at which the plate reaches moisture equilibrium is seen to decrease as T_i is increased for a fixed value of $h = 0.2$ cm.

In what follows, the effect of sudden change of surface temperature on the moisture uptake in the plate will be studied.

SUDDEN CHANGE IN TEMPERATURE

In order to study the influence of a sudden temperature on a composite that is kept in a constant moisture environment, it is necessary to use the coupled theory since the moisture diffusion equation for the uncoupled theory applies only to the case of constant temperature.

Suppose that the surface temperature on the plate in Figure 1 is raised from an initial value of T_i to a final value T_f and the moisture concentrations at $z = \pm h/2$ are kept constant at all time. Then, in addition to equations (6), the following conditions must also prevail:

$$T(\pm h/2, t) = T_f, C(\pm h/2, t) = C_i \quad (28)$$

The form of the solution expressed in terms of the variables ξ and θ defined in equations (4) is

$$C(t) = C_i + \lambda(T_f - T_i) f(\xi, \theta) \quad (29)$$

$$T(t) = T_i + (T_f - T_i) g(\xi, \theta)$$

Without going into details, the governing differential equations become

$$\frac{\partial f}{\partial \theta} = \frac{F}{1-\lambda\nu} \left[\frac{\partial^2 f}{\partial \xi^2} + \frac{AB}{(1+g)^2} \frac{\partial f}{\partial \xi} \frac{\partial g}{\partial \xi} \right] + \frac{1}{u_0} \frac{\partial^2 g}{\partial \xi^2} \quad (30)$$

$$\frac{\partial g}{\partial \theta} = \frac{1+\lambda\nu}{u_0} \frac{\partial^2 g}{\partial \xi^2} + \frac{\lambda\nu}{1-\lambda\nu} F \left[\frac{\partial^2 f}{\partial \xi^2} + \frac{AB}{(1+Bg)^2} \frac{\partial f}{\partial \xi} \frac{\partial g}{\partial \xi} \right]$$

where u_0 is given by equation (10). Refer to equations (11) and (12) for the definition* of A, B and the function F. Making use of equations (29), the conditions in equations (28) may be written as

$$f(\pm 1, \theta) = 0, \quad g(\pm 1, \theta) = 1 \quad \text{for } \theta \geq 0 \quad (31)$$

As in the previous example, equations (30) will be solved numerically by the finite difference method.

Finite difference equations. Equations (30) will now be cast into the finite difference form. With the nondimensional time and space interval as chosen in Figure 2, the following expressions are obtained:

$$\begin{aligned} \frac{f_{m,n+1} - f_{m,n}}{\Delta \theta} = & \frac{F(m,n)}{1-\lambda\nu} \left[\frac{f_{m+1,n} - 2f_{m,n} + f_{m-1,n}}{(\Delta \xi)^2} + \frac{AB}{(1+Bg_{m,n})^2} \left(\frac{f_{m+1,n} - f_{m,n}}{\Delta \xi} \right) \times \right. \\ & \left. \times \left(\frac{g_{m+1,n} - g_{m,n}}{\Delta \xi} \right) \right] + \frac{1}{u_0} \left[\frac{g_{m+1,n} - 2g_{m,n} + g_{m-1,n}}{(\Delta \xi)^2} \right] \quad (32) \end{aligned}$$

* With the exception of B which in the case of sudden temperature change should read as $(T_f - T_i)/T_i$ instead of that in equation (12) for the case of sudden moisture change.

and

$$\begin{aligned}
 \frac{g_{m,n+1} - g_{m,n}}{\Delta\theta} &= \frac{1+\lambda\nu}{u_0} \left[\frac{g_{m+1,n} - 2g_{m,n} + g_{m-1,n}}{(\Delta\xi)^2} \right] + \frac{\lambda\nu}{1-\lambda\nu} F(m,n) \times \\
 &\times \left[\frac{f_{m+1,n} - 2f_{m,n} + f_{m-1,n}}{(\Delta\xi)^2} + \frac{AB}{(1+Bg_{m,n})^2} \left(\frac{f_{m+1,n} - f_{m,n}}{\Delta\xi} \right) \times \right. \\
 &\times \left. \left(\frac{g_{m+1,n} - g_{m,n}}{\Delta\xi} \right) \right] \quad (33)
 \end{aligned}$$

The stability requirement for selecting the relative size of Δt and Δz in the numerical calculation is the same as that stated in equation (15).

Moisture content. Following the definitions of the various moisture parameters as discussed earlier, the average moisture content in the composite per unit mass of solid is

$$\bar{m}(t) - m_i = \frac{\omega}{2\lambda} (T_f - T_i) \int_{-1}^1 [f(\xi, \theta) - g(\xi, \theta)] d\xi \quad (34)$$

From equation (19), it can be shown that

$$m_f - m_i = -\omega(T_f - T_i) \quad (35)$$

which when substituted into equation (34) yields

$$\begin{aligned}
 \frac{\bar{m}(t) - m_i}{m_f - m_i} &= \frac{1}{2} \left(\frac{\Delta\xi}{3} \right) \{ [g(1, \theta_0) + 4g(2, \theta_0) + \dots + g(n, \theta_0)] \\
 &- [f(1, \theta_0) + 4f(2, \theta_0) + \dots + f(n, \theta_0)] \} \quad (36)
 \end{aligned}$$

Simpson's rule has been applied for evaluating the integral in equation (34) at $\theta = \theta_0$.

Numerical example. Referring to the conditions prescribed by equations (6) and (28), the moisture concentrations at $z = \pm h/2$ are to be kept at C_i while the surface temperature will be raised from T_i to T_f . Assuming that the mass of moisture contained in the voids per unit volume of void space on the boundary is constant, then the relative humidity of the ambient air will decrease as the temperature is raised*. The opposite occurs when the RH is increased. As it is to be expected, an increase in the ambient temperature will cause moisture desorption while a decrease in the ambient temperature leads to moisture absorption. These results are summarized in graphical form for the T300/5208 epoxy resin with the coupling constants $u = 0.1$, $\lambda = 0.5$ and $\nu = 0.5$ as determined earlier.

Figures 10 to 12 give plots of $\bar{m}(t)$ as a function of $2z/h$ for $T_i = 21^\circ\text{C}$ and $(\text{RH})_i = 52\%$ and three different values of $T_f = 0^\circ\text{C}$, 10°C and 12.78°C . Each graph contains 6 curves corresponding to the time elapsed starting from $t = 11.7$ hrs to 1,961 hrs inclusive as indicated. For these cases, ΔT is negative and the moisture level in the plate will increase with time. The differences between the curves diminish as the equilibrium condition is approached. With the same initial conditions, Figures 13 to 15 display the results for ΔT positive

*As an example, if initially $T_i = 21^\circ\text{C}$, $P_i = 0.18125$ psi and $(\text{RH})_i = 52\%$, then the $(\text{RH})_f$ of the final state for $T_f = 43^\circ\text{C}$ and $P_f = 1.2748$ psi can be calculated from

$$(\text{RH})_f = \frac{P_i}{P_f} \left(\frac{T_f}{T_i} \right) = \frac{0.18125}{1.2748} \left(\frac{316}{294} \right) = 15.28\%$$

where P_f is the saturated vapor pressure at the temperature T_f .

where $T_f = 43^\circ\text{C}$, 63°C and 83°C are all greater than $T_i = 21^\circ\text{C}$. The opposite trend is observed, i.e., the moisture level in the plate will now decrease with time until an equilibrium state is reached. The influence of ΔT on $\bar{m}(t)$ can be best illustrated by plotting $\bar{m}(t)$ versus \sqrt{t} at $2z/h = 0.5$ as shown in Figure 16. The curves for the 6 different values of T_f offer a quantitative assessment of moisture absorption and desorption as ΔT changes sign.

Influence of coupling. An attempt is made in Figure 17 to illustrate the difference between the coupled solution obtained from equations (3) and the uncoupled equation

$$\frac{\partial}{\partial z} \left(D \frac{\partial C}{\partial z} \right) - \frac{\partial C}{\partial t} = 0 \quad (37)$$

Note that for $(RH)_i = 52\%$, the dotted curves based on equation (37) can differ significantly from the solid curves of the coupled theory. In the case of $(RH)_i = 100\%$ and $T_i = 21^\circ\text{C}$ changes to $T_f = 43^\circ\text{C}$, the difference is even more appreciable, Figure 18.

The foregoing results reveal that the coupling of moisture and heat is inherent in the study of sudden temperature change in composites at a given moisture level. The extent to which coupling influences the mechanical behavior of the composite can be evaluated by calculating for the stresses and/or strains. This will be done in the section to follow.

TRANSIENT STRESSES

The mechanical behavior of composites may be altered when exposed to high temperature and/or moisture environments. Their behavior should be understood before the full potential of composites can be realized. For the resin-base com-

posite treated earlier, moisture is assumed to diffuse into the solid in much the same way as heat. It tends to degrade the mechanical properties and introduce dimensional changes of the composite similar to those caused by thermal changes. In this preliminary analysis, the coupling of these two effects will be assumed only in the diffusion process while the hydroelastic and thermal elastic stresses are taken to be additive.

Basic equations. Let the plate in Figure 1 extend to infinity in both the x and y directions and be free from mechanical loads*. The material of the plate is assumed to be isotropic and homogeneous. Only hydrothermal stresses will be treated, i.e.,

$$\sigma_{ij} = E(\epsilon_{ij} - \alpha\Delta T - \beta\Delta m) \quad (38)$$

where E is the Young's modulus of elasticity, α the coefficient of thermal expansion and β the coefficient of moisture expansion. The quantity, m, is defined by equation (19). Since the stress state is a function of the thickness variable z only, shear stresses vanish everywhere and σ_{ij} and ϵ_{ij} consist of normal components only. Hence, the strain and stress relations may be written as

$$\begin{aligned} \epsilon_x &= \frac{1}{E} [\sigma_x - \nu_p (\sigma_y + \sigma_z)] \\ \epsilon_y &= \frac{1}{E} [\sigma_y - \nu_p (\sigma_x + \sigma_z)] \\ \epsilon_z &= \frac{1}{E} [\sigma_z - \nu_p (\sigma_x + \sigma_y)] \end{aligned} \quad (39)$$

*The stresses induced by mechanical loads can simply be added into those due to moisture and heat.

where ν_p is the Poisson's ratio and $\sigma_z = 0$ will be assumed.

For the isotropic and homogeneous material, the stresses induced by the strains

$$\epsilon_x^0 = \epsilon_y^0 = -\alpha\Delta T - \beta\Delta m \quad (40)$$

are given by

$$\sigma_x^0 = \sigma_y^0 = -\frac{\alpha E \Delta T}{1-\nu_p} - \frac{\beta E \Delta m}{1-\nu_p} \quad (41)$$

which prevails everywhere in the plate.

In order to free the plate edges from external stresses, it is necessary to apply stresses, equal in magnitude and opposite in direction, to those of equation (41). The following average tensile stresses

$$\bar{\sigma}_x = \bar{\sigma}_y = \frac{1}{(1-\nu_p)h} \left[\alpha E \int_{-h/2}^{h/2} \Delta T dz + \beta E \int_{-h/2}^{h/2} \Delta m dz \right] \quad (42)$$

are thus introduced. The final result for a free edge plate is

$$\sigma_x = \sigma_y = \frac{\alpha E}{1-\nu_p} (\bar{T}-T) + \frac{\beta E}{1-\nu_p} (\bar{m}-m) \quad (43)$$

in which \bar{T} and \bar{m} are the temperature and moisture averaged through the plate thickness.

Moisture change. Based on the diffusion results obtained earlier, equation (43) is applied to find the stresses. For the T300/5208 resin, the following

material properties are used:

$$\alpha = 45 \times 10^{-6} \text{ cm/cm/}^\circ\text{C} \quad (25 \times 10^{-6} \text{ cm/cm/}^\circ\text{F})$$

$$\beta = 2.68 \times 10^{-3} \text{ cm/cm/\% m(t) H}_2\text{O}$$

(44)

$$\nu_p = 0.34$$

$$E = 3.45 \text{ Gpa} \quad (0.5 \times 10^6 \text{ psi}) \text{ at } 21^\circ\text{C}$$

The hydrothermal stress distribution throughout the plate thickness is shown graphically from Figures 19 to 23 as RH is changed from 0% to 13%, 33%, 52%, 75% and 98% with $T_i = T_f = 21^\circ\text{C}$. Initially, both moisture and temperature are at the equilibrium state and hence give rise to no stress. As the relative humidity on the plate surfaces is altered, moisture absorption begins. This causes contraction and/or expansion of the material elements and leads to hydrothermal stresses that vary as a function of z and t . It can be easily seen from the graphs that the stresses near the surface are compressive and their magnitude decrease as the plate thickness is increased. These stresses become tensile in regions close to the center of the plate. They increase in magnitude reaching the maximum value at $t \approx 1,571$ hr and then begins to decrease settling at the zero equilibrium state. This trend is similar to the results of the uncoupled theory [2] and is to be expected since the influence of coupling due to diffusion was weak for the case of sudden moisture change.

The variations of the stresses σ_x (or σ_y) for $z=0$ and $\pm h/2$ with time are summarized in Figures 24 and 25, respectively. Figure 24 shows clearly that the stresses at the midplane are tensile. They rise quickly to a peak and then de-

cay. Their amplitude increases with the relative humidity of the environment. The time variation of the compressive stresses at the plate surfaces is similar except that the peaks are much more pronounced. This is illustrated in Figure 25.

Temperature change. Now, let the moisture concentration on the plate be a constant and change the surface temperature which is initially kept at the ambient condition $T_i = 21^\circ\text{C}$ and $(\text{RH})_i = 52\%$. Figures 26 to 28 show the results of σ_x (or σ_y) against $2z/h$ for $T_f = 0^\circ\text{C}$, 10°C and 12.78°C . This corresponds to a temperature drop. The tensile stresses in the interior increase in magnitude while the compressive stresses near the plate surface decrease in magnitude. The peak tensile stress occurs at $t \approx 1,961$ hr. The opposite trend is observed when the surface temperature is raised. Figures 29 and 30 give the results for $T_f = 43^\circ\text{C}$ and 63°C . The stresses at the center region now becomes compressive and those near the surface are tensile. Maximum value of the compressive stress at $z=0$ occurs at $t \approx 791$ hr.

The time-dependent character of the stresses is exhibited in Figures 31 and 32 for $z=0$ and $z = \pm h/2$. For $z=0$, σ_x (or σ_y) increases in amplitude to a peak and then decreases for negative ΔT while σ_x (or σ_y) attains an oscillatory character when ΔT is positive. On the surface where $z = \pm h/2$, all the stresses, whether tensile or compressive, reach a peak and then reduce to the equilibrium condition of zero stress.

Comparison with uncoupled theory. The stress results for the uncoupled theory are also observed such that a comparison with the coupled theory can be made. Figures 33 to 39 for the uncoupled case correspond, respectively, to the results in Figures 26 to 32 for the coupled case. Although the general trend of the

curves may be similar, there are noticeable differences in the stress amplitudes. In order to be more specific, Table 1 gives a comparison of the stresses at $z=0$ and $z = \pm h/2$ for 6 different values of the final temperature. The percent of deviation between the results of the coupled and uncoupled theory is calculated for elapsed time $t = 11.7$ hr, 402 hr and 1,961 hr. The largest deviation occurs at $t = 1,961$ hr. Note that for positive ΔT , i.e., temperature increase, the coupling of moisture and heat can alter the stress anywhere from 40 to 80 percent depending on ΔT . In such cases, the stresses predicted from the uncoupled theory may not adequately model the physical problem.

CONCLUSIONS

For the T300/5208 epoxy resin composite material treated in this study, it is seen that the interaction of moisture and heat can significantly alter the stress distribution in the composite. Although thermal and moisture diffusion do not peak simultaneously because of the wide margin of difference between the coefficients α and β , the way in which moisture and heat interact in a solid is complicated and cannot be disposed on intuitive grounds. In particular, when a composite is subjected to a sudden temperature change on its surface the transient stresses predicted from the coupled and uncoupled theory can differ appreciably.

In this preliminary analysis, material isotropy and homogeneity have been assumed. These simplifications should be further investigated by incorporating the real structure of the composite. What lies ahead is the formulation of a finite difference method that treats three independent variables: two in space (x,y) and one in time (t). This will permit an evaluation on the effect of material anisotropy, the presence of cavities and nonuniform temperature and/or moisture boundary conditions. These additional influences will also interact

TABLE 1 - PERCENT DEVIATION OF STRESSES IN T300/5208 FOR
 COUPLED AND UNCOUPLED THEORY WITH $T_i = 21^\circ\text{C}$ AND
 $(RH)_i = 52\%$

Final Temperature	Time (hr)	Stress at Surface (psi)			Stress at Midplane (psi)		
		Coupled	Uncoupled	Dev. %	Coupled	Uncoupled	Dev. %
0°C	11.70	-1622.82	-1637.52	0.91	85.46	70.75	17.2
	401.5	-1685.47	-1931.90	14.63	196.41	137.76	29.9
	1961.0	-1566.77	-1966.08	25.49	436.03	536.38	23.0
10°C	11.70	-1015.07	-1024.26	0.91	56.13	46.94	16.37
	401.5	- 989.52	-1134.84	14.69	166.18	139.11	16.29
	1961.0	- 837.88	-1060.13	26.53	345.44	427.36	23.71
12.78°C	11.70	- 608.12	- 613.64	0.91	31.77	26.25	17.37
	401.5	- 607.79	- 696.35	14.57	107.10	89.68	16.26
	1961.0	- 509.24	- 646.47	26.95	229.71	285.67	24.36
43°C	11.70	402.05	405.88	0.95	- 0.96	2.87	
	401.5	513.22	586.51	14.28	-203.48	-192.23	5.53
	1961.0	226.98	317.31	39.8	-133.22	-184.71	38.65
63°C	11.70	51.81	52.78	1.87	46.97	47.94	2.06
	401.5	358.10	420.71	17.48	-238.39	-252.01	5.71
	1961.0	47.35	67.25	42.03	- 28.15	- 39.39	39.92
83°C	11.70	-465.37	-468.67	0.71	106.22	102.92	3.11
	401.5	64.35	113.84	76.9	-138.60	-190.21	37.24
	1961.0	- 5.28	- 0.84	84.1	2.82	0.299	89.40

with moisture and heat and should be assessed quantitatively such that their individual contribution on the overall mechanical behavior of the composite can be understood.

ACKNOWLEDGEMENTS

The authors are particularly grateful to Professor S. I. Tsai of National Taiwan University who carried out the initial formulation of the finite difference method in this paper during his visit at Lehigh. The many helpful suggestions made by Professor R. J. Hartranft of Lehigh University are also acknowledged.

REFERENCES

- [1] Shen, C. H. and Springer, G. S., "Moisture Absorption and Desorption of Composite Materials", Journal of Composite Materials, Vol. 10, pp. 2-20, 1976.
- [2] Pipes, R. B., Vinson, J. R. and Chou, T. W., "On the Hygrothermal Response of Laminated Composite Systems", Journal of Composite Materials, Vol. 10, pp. 129-148, 1976.
- [3] Hartranft, R. J. and Sih, G. C., "The Influence of Coupled Diffusion of Heat and Moisture on the State of Stress in a Plate", Lehigh University Institute of Fracture and Solid Mechanics Report IFSM-78-93, August 1978.
- [4] Hartranft, R. J. and Sih, G. C., "The Influence of the Soret and Dufour Effects on the Diffusion of Heat and Moisture in Solids", Lehigh University Institute of Fracture and Solid Mechanics Report IFSM-78-92, June 1978.

- [5] Shirrell, C. D., "Moisture Diffusion in Advanced Composite Resin Matrix Laminates", AFML Progress Report, Bergamo Center, October 1977.
- [6] Jost, W., Diffusion in Solids, Liquids, Gases, Academic Press, New York, 1952.
- [7] Hartranft, R. J., Sih, G. C. and Chen, T. S., "Interaction of Temperature and Moisture in Diffusion", Lehigh University Institute of Fracture and Solid Mechanics Report IFSM-77-82, August 1977.

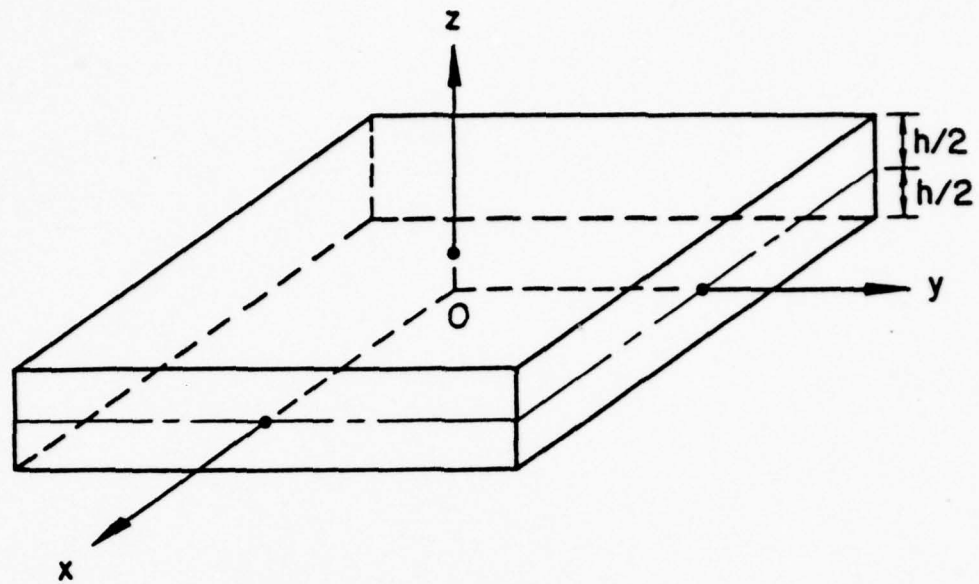

Figure 1 - Diffusion of moisture and/or temperature in an infinite plate with finite thickness

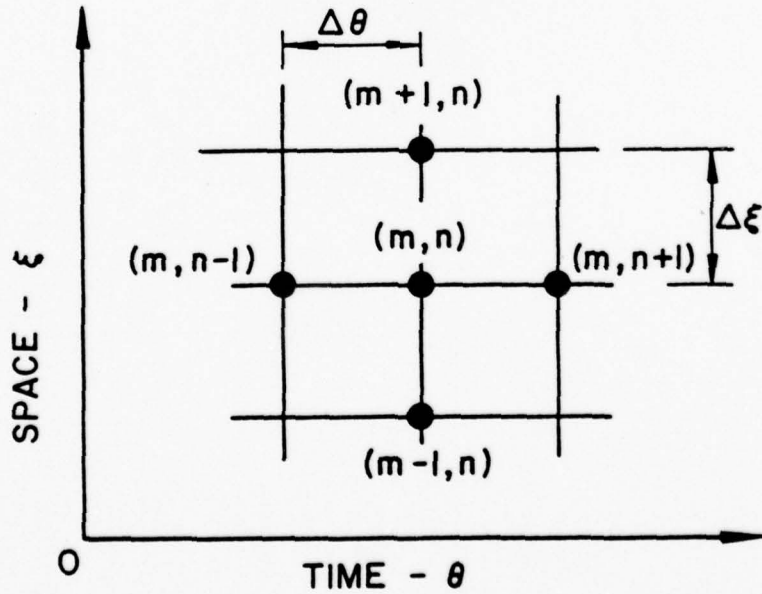

Figure 2 - Finite difference mesh in dimensionless space and time variables

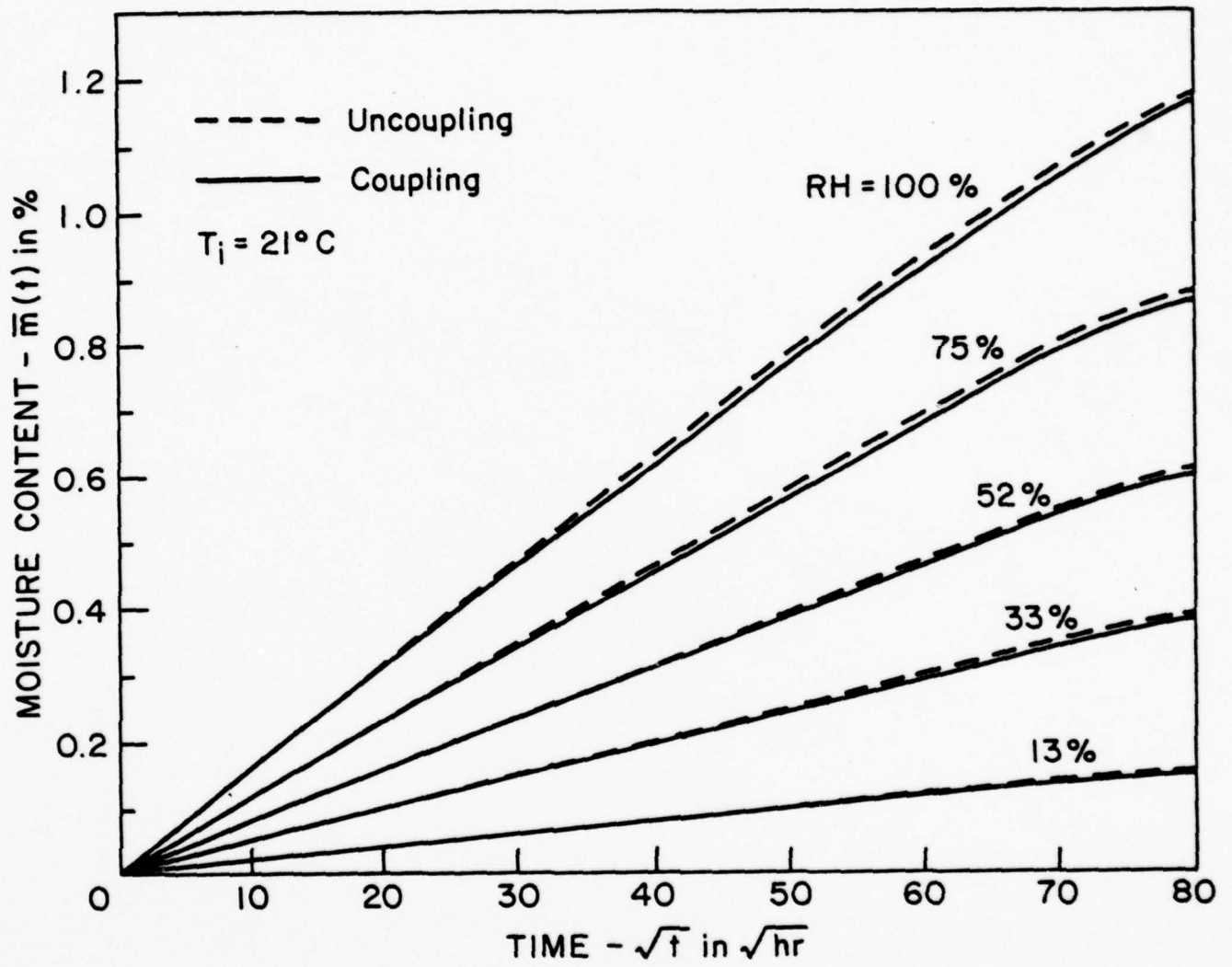

Figure 3 - Variations of moisture content with time caused by sudden change in moisture for T300/5208

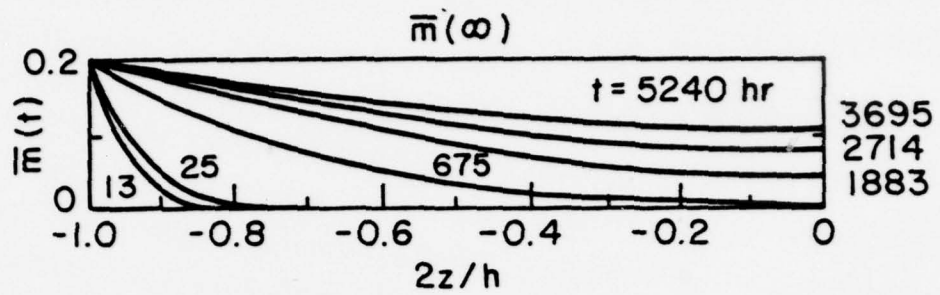

Figure 4 - Sudden moisture change from RH = 0% to 13% at 21°C for T300/5208

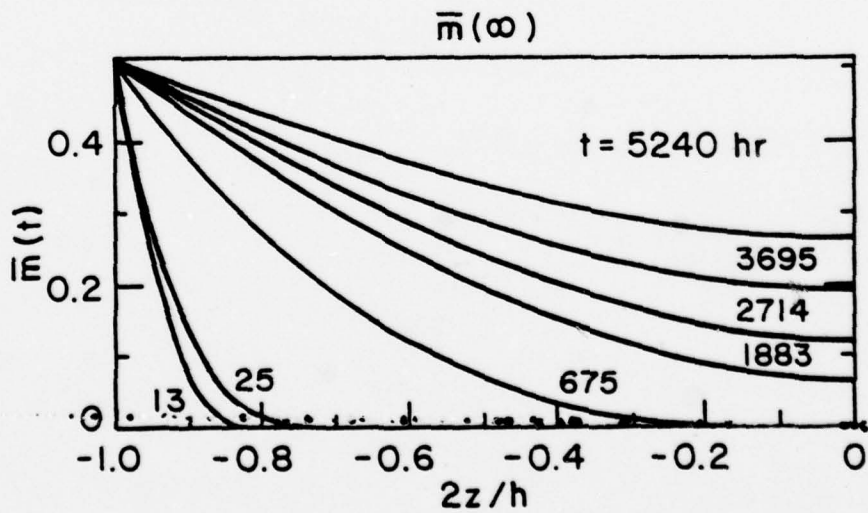

Figure 5 - Sudden moisture change from RH = 0% to 33% at 21°C for T300/5208

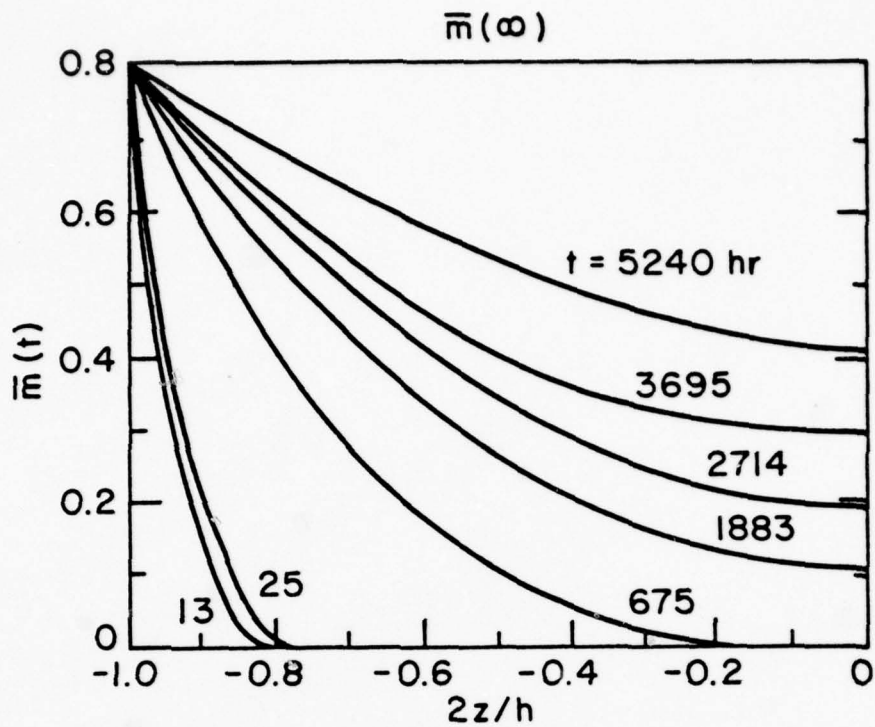

Figure 6 - Sudden moisture change from RH = 0% to 52% at 21°C for T300/5208

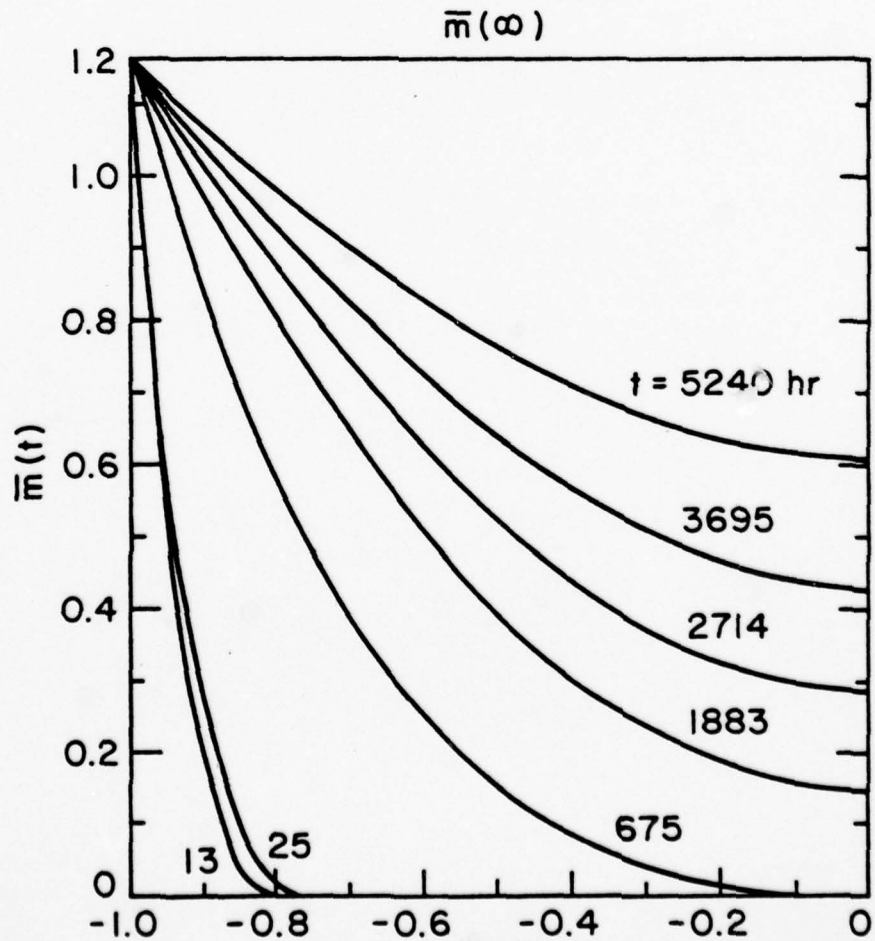

Figure 7 - Sudden moisture change from RH = 0% to 75% at 21°C for T300/5208

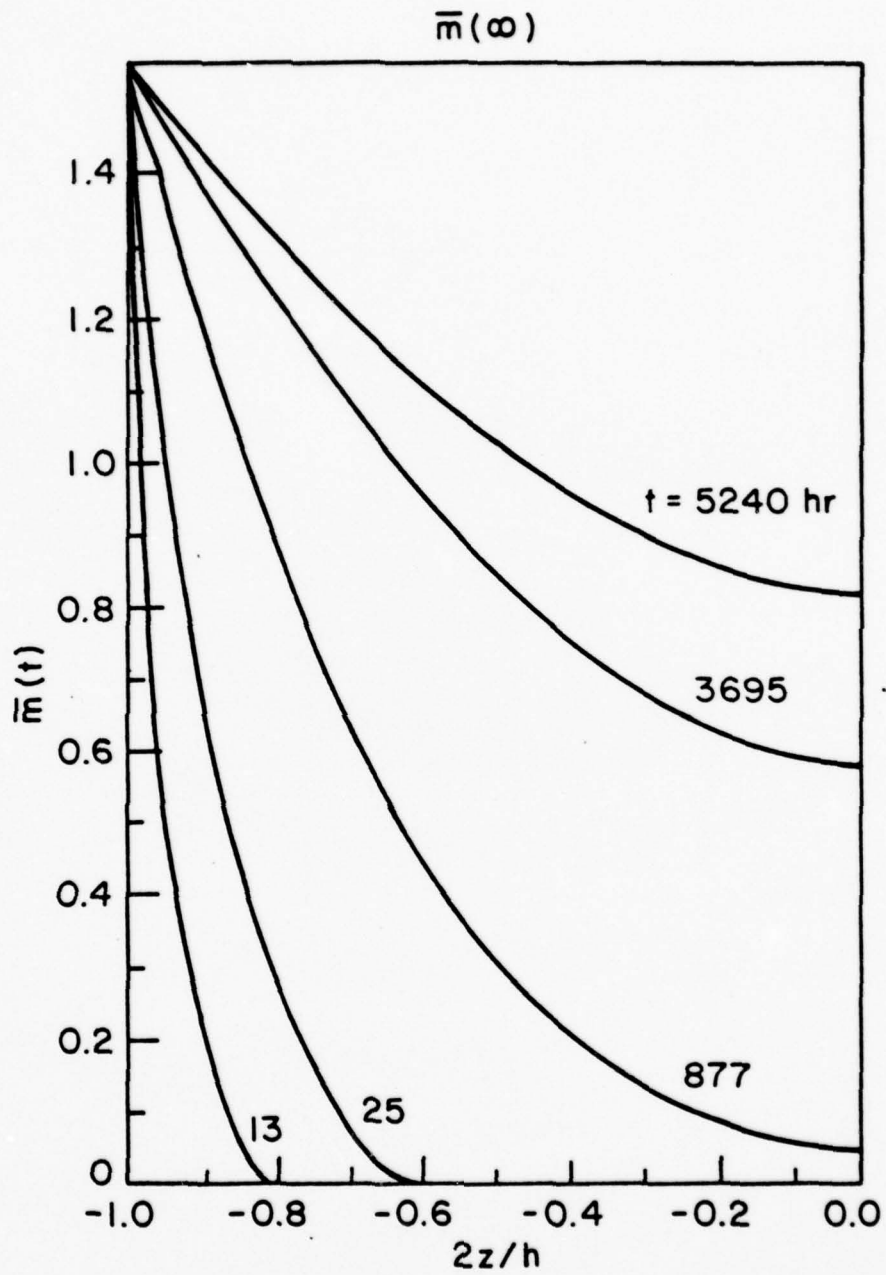

Figure 8 - Sudden moisture change from RH = 0% to 100% at 21°C for T300/5208

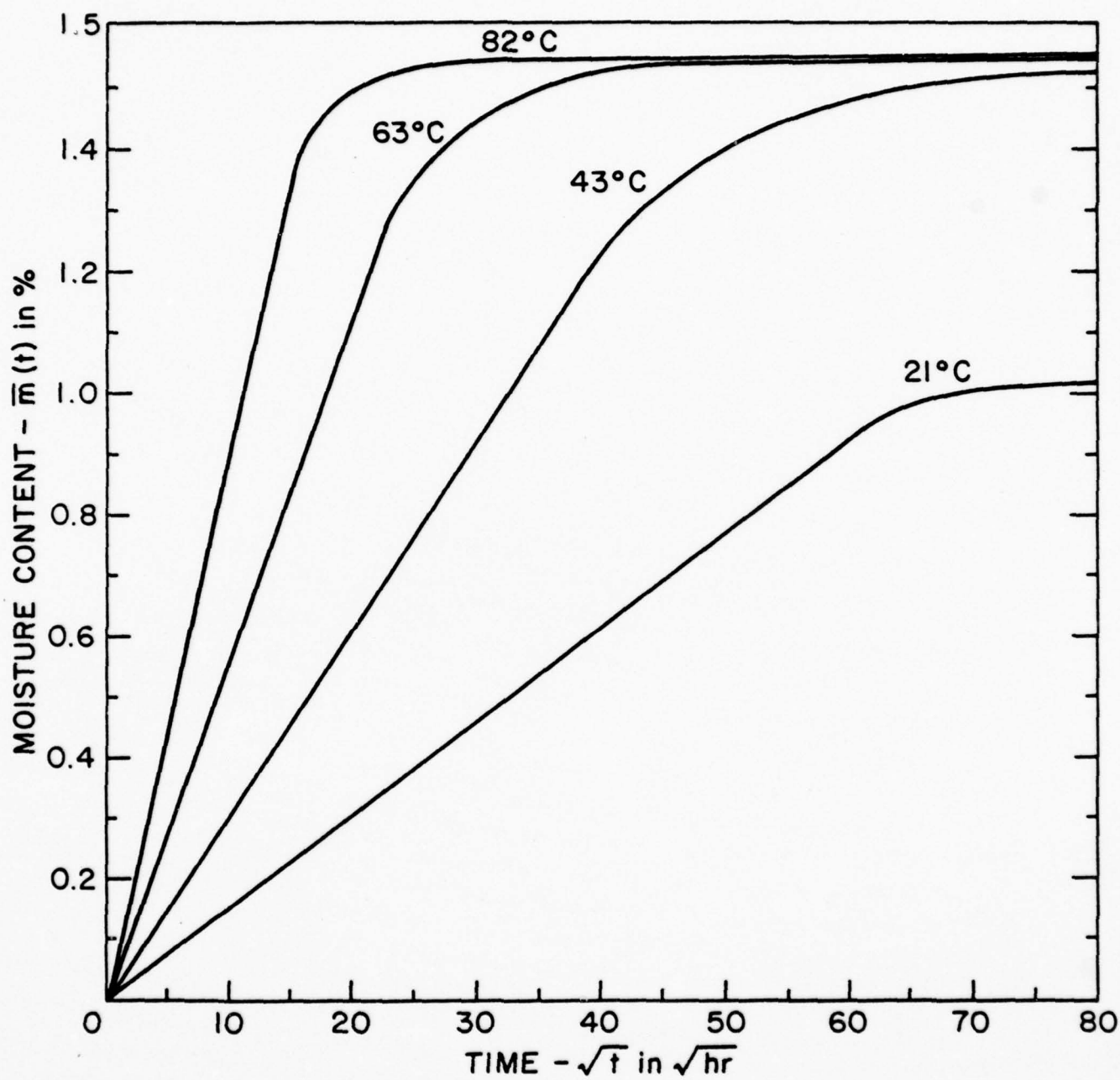

Figure 9 - Moisture absorption speed for T300/5208 in RH = 100% air with different temperature based on uncoupled theory

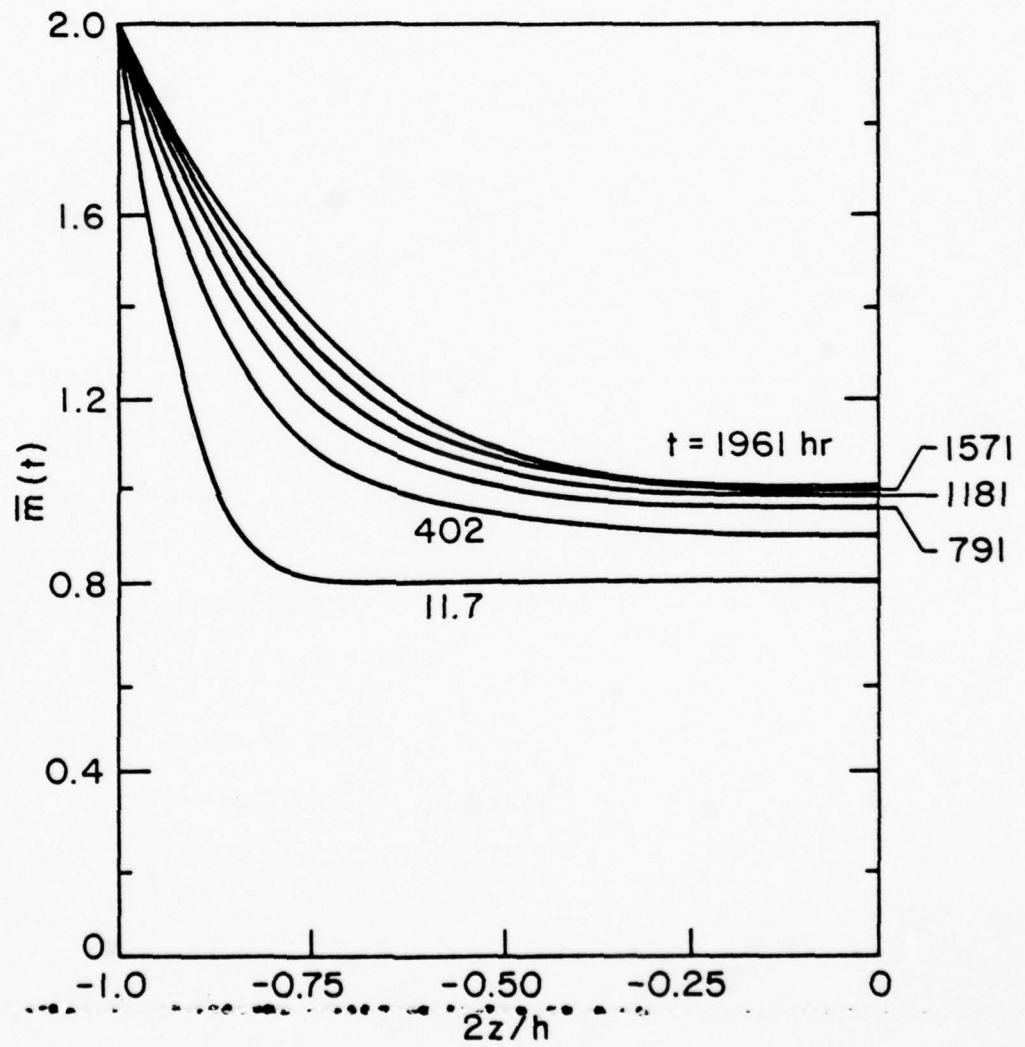

Figure 10 - Sudden temperature change from 21°C (RH = 52%) to 10°C for T300/5208

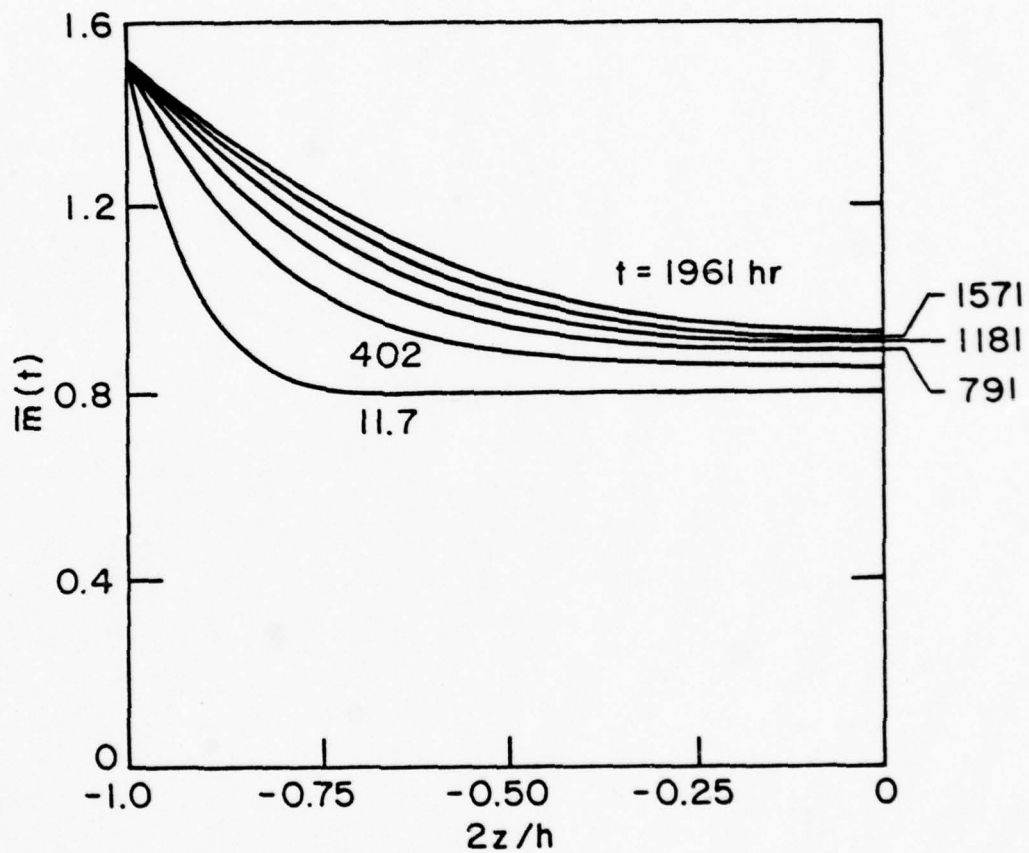

Figure 11 - Sudden temperature change from 21°C (RH = 52%) to 10°C for T300/5208

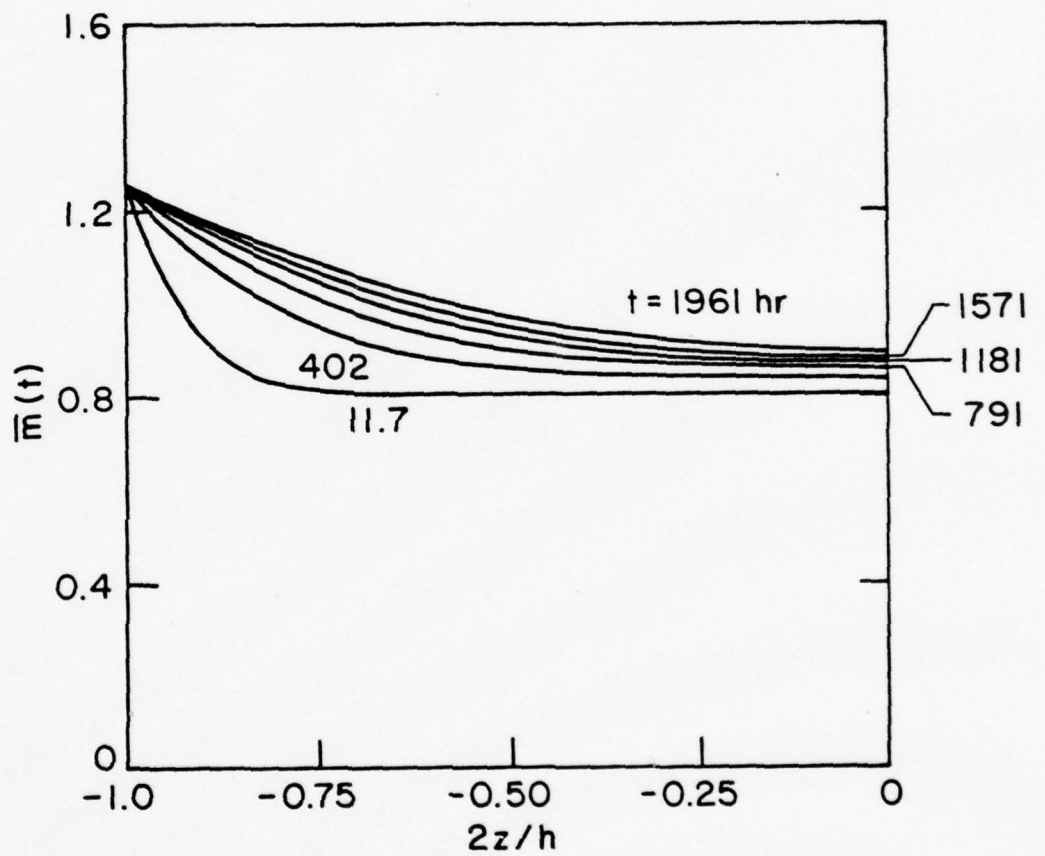

Figure 12 - Sudden temperature change from 21°C (RH = 52%) to 12.78°C for T300/5208

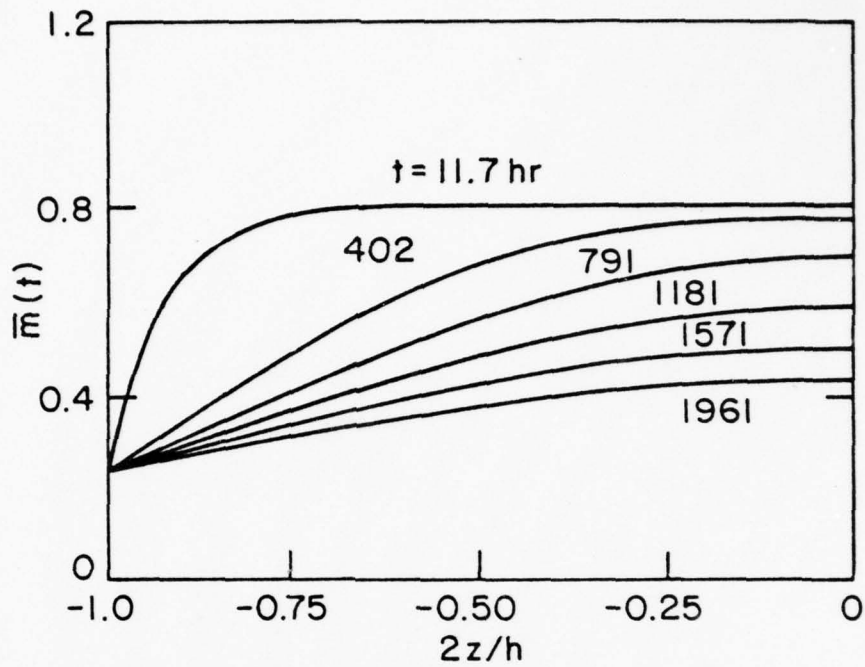

Figure 13 - Sudden temperature change from 21°C (RH = 52%) to 43°C for T300/5208

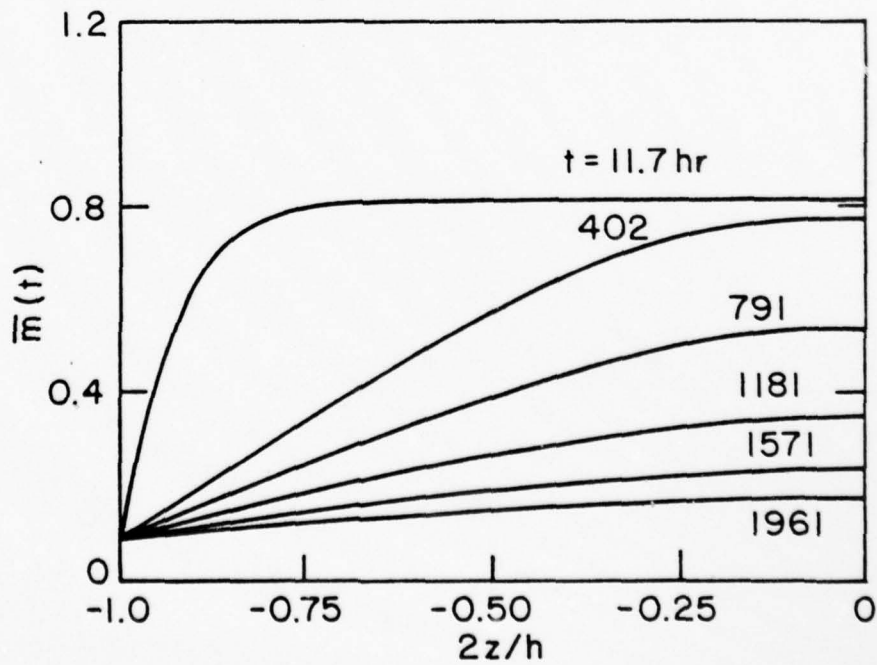

Figure 14 - Sudden temperature change from 21°C (RH = 52%) to 63°C for T300/5208

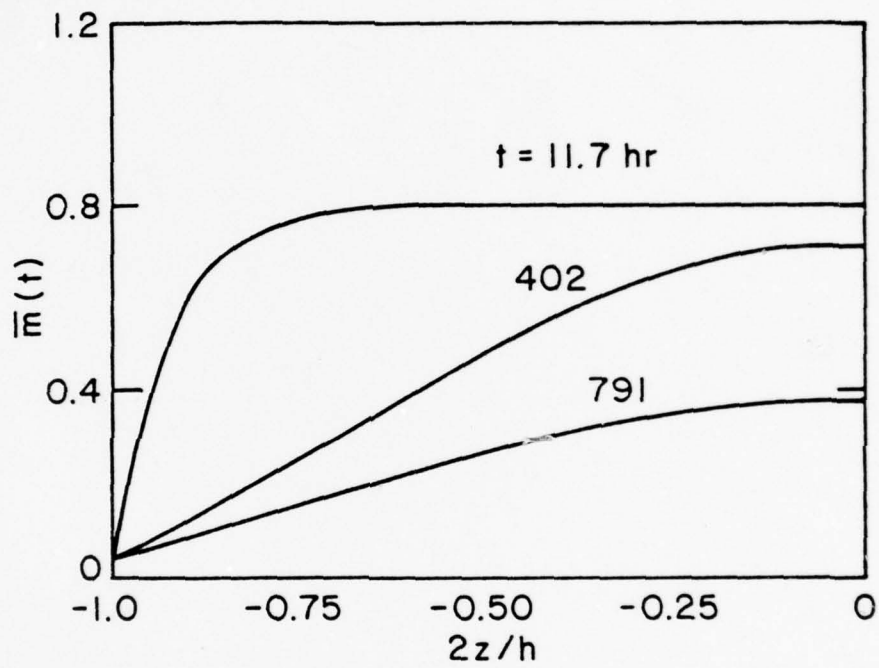

Figure 15 - Sudden temperature change from 21°C (RH = 52%) to 83°C for T300/5208

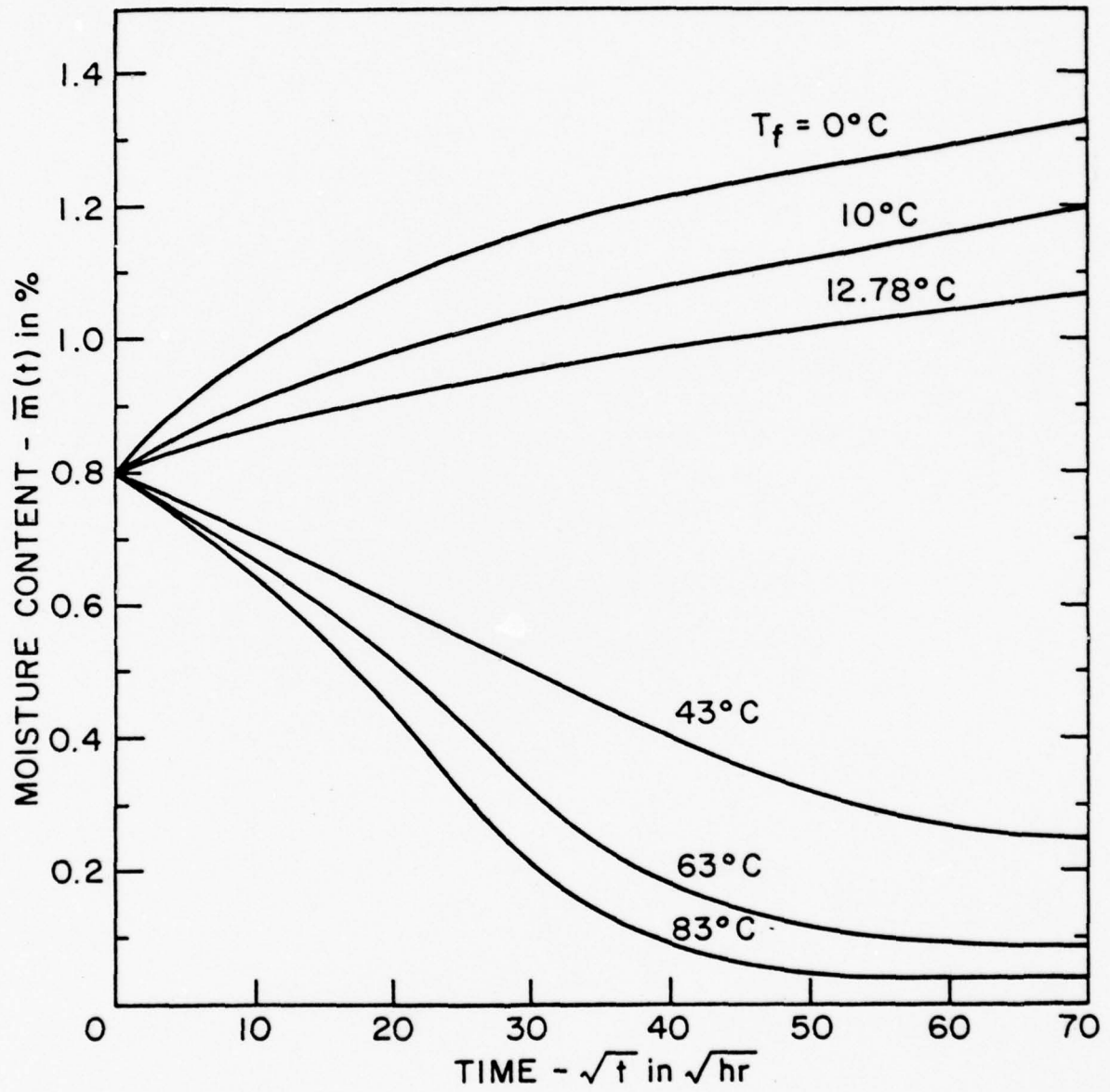

Figure 16 - Moisture absorption and desorption speed for different temperature gradients at ambient condition of 21°C and RH = 52% (T300/5208)

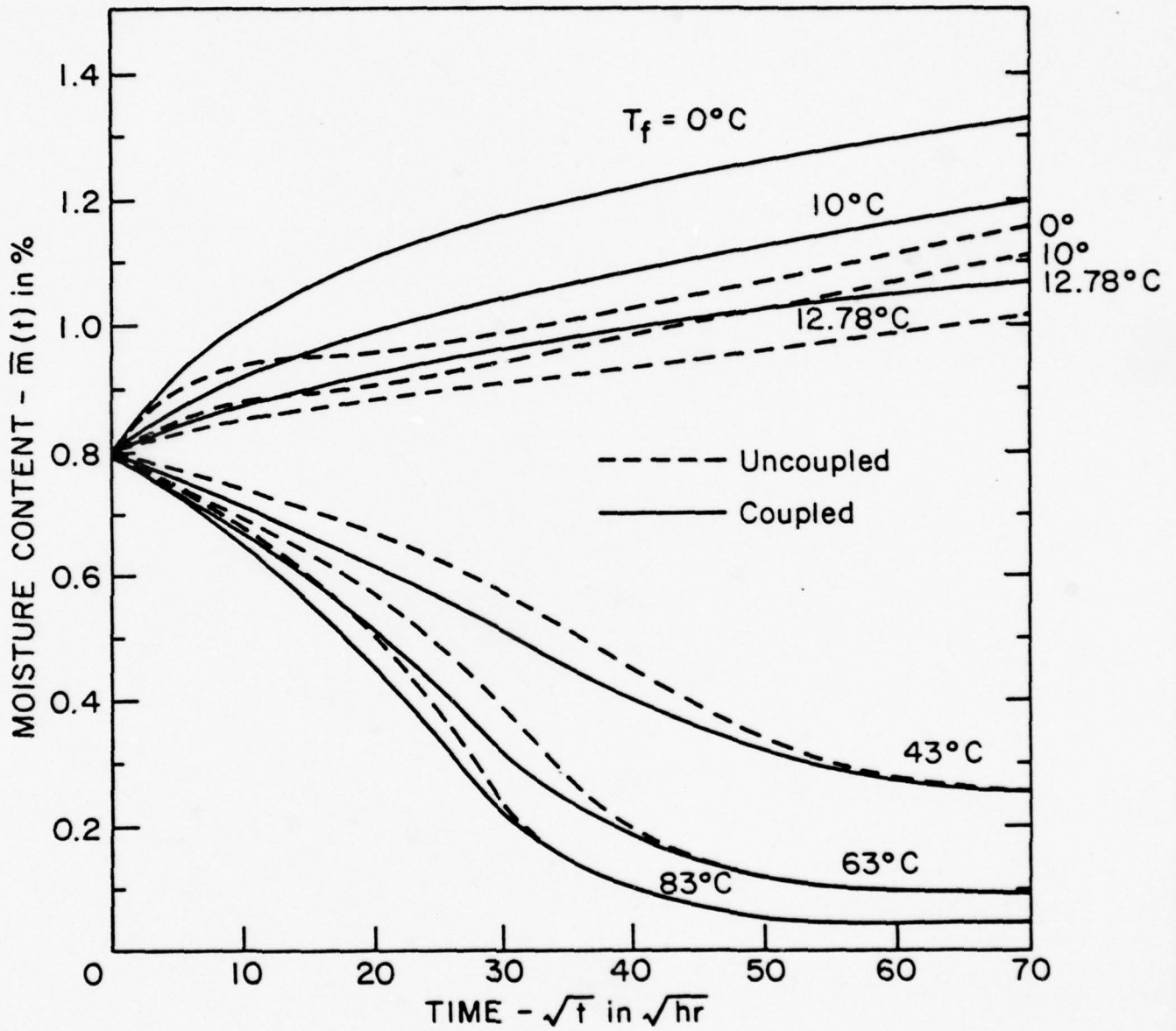

Figure 17 - Comparison of coupled and uncoupled results for moisture absorption and desorption speed with ambient condition of 21°C and RH = 52% (T300/5208)

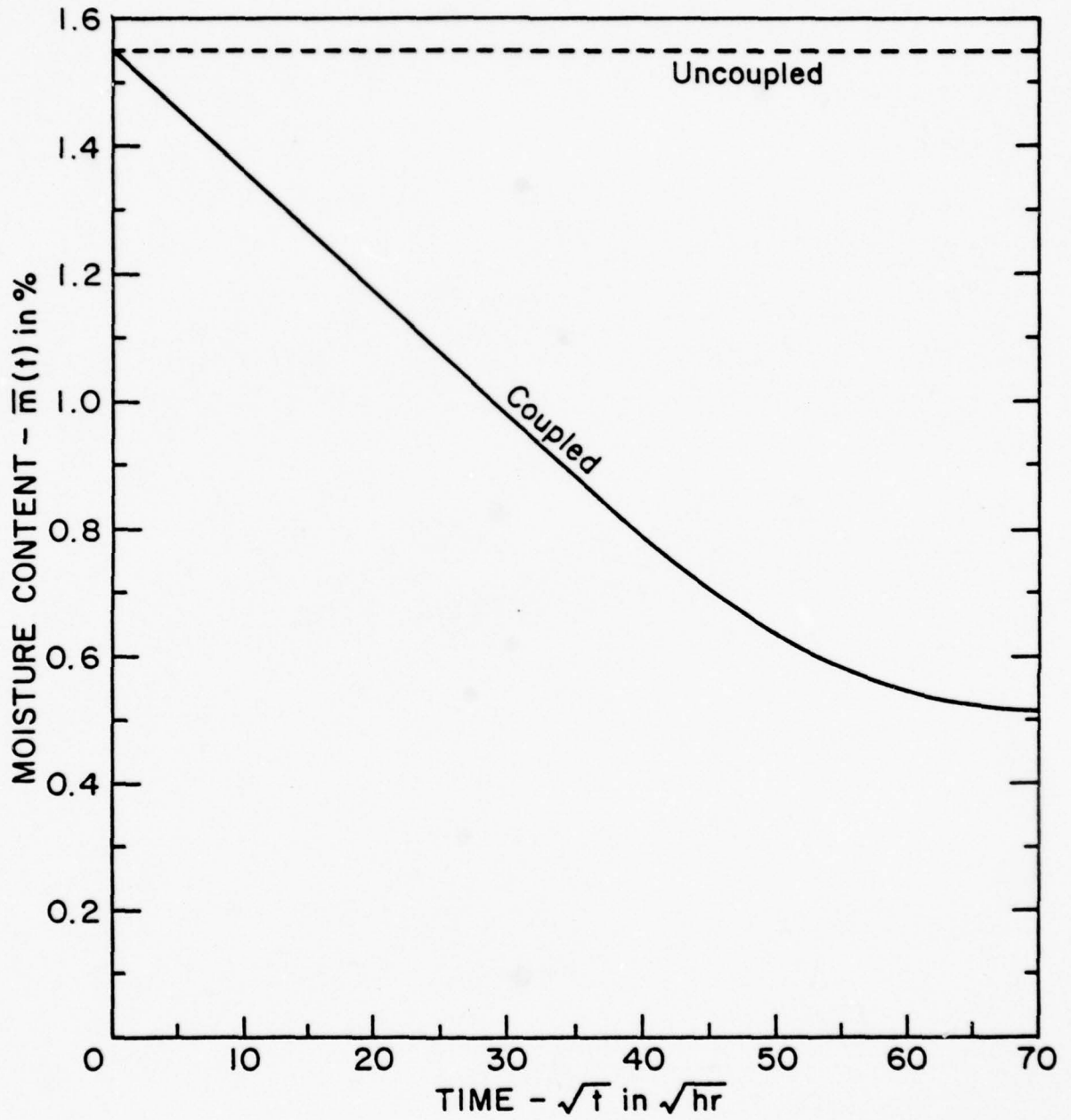

Figure 18 - Moisture desorption due to temperature change from 21°C (RH = 100%) to 43°C for T300/5208

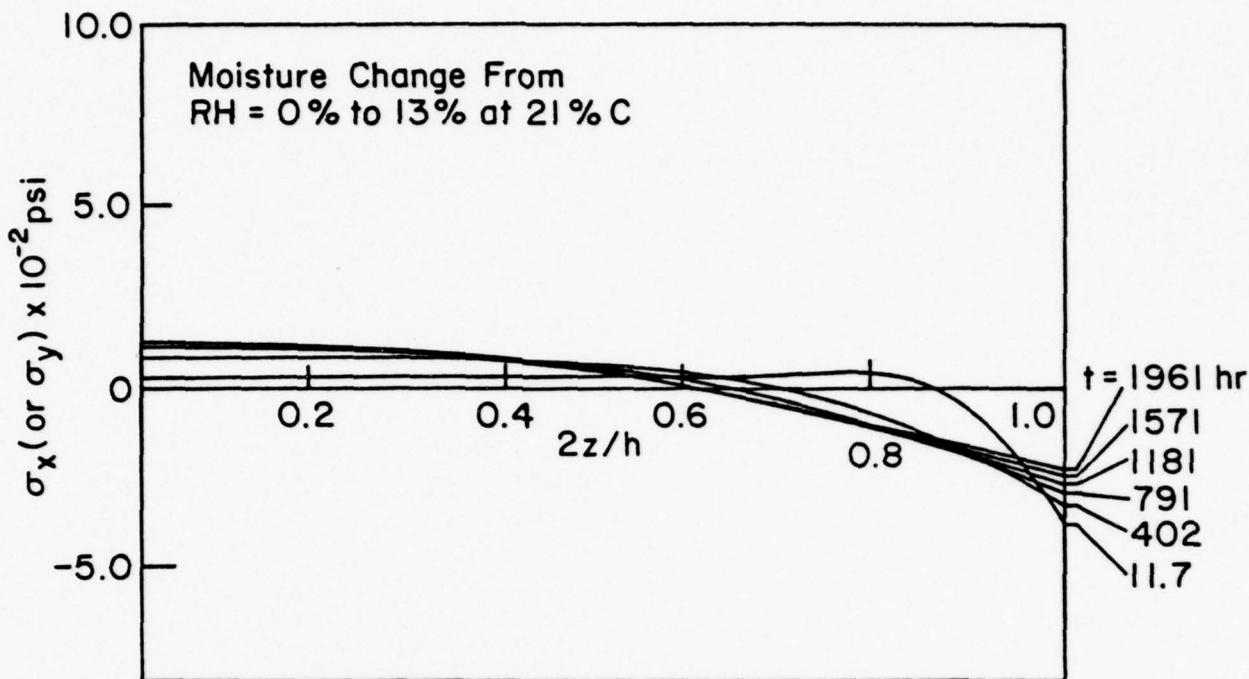

Figure 19 - Stress variations for $(RH)_f = 13\%$

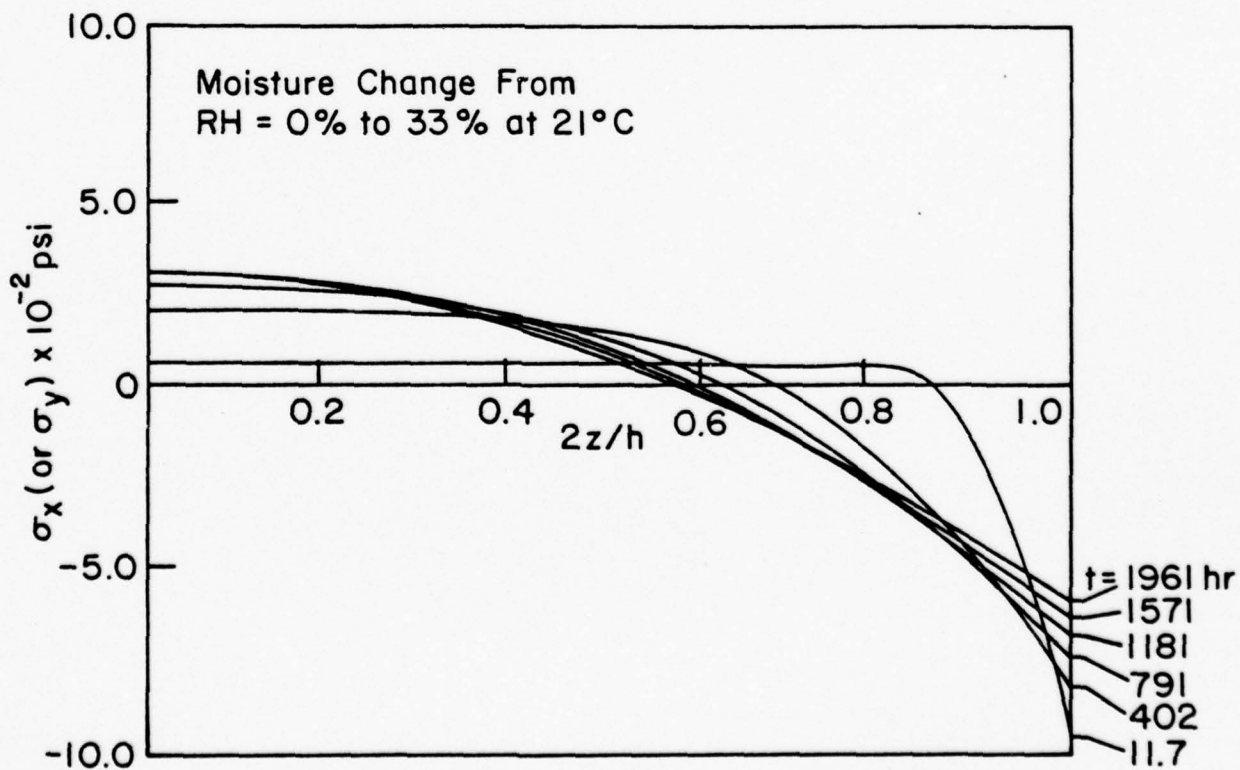

Figure 20 - Stress variations for $(RH)_f = 33\%$

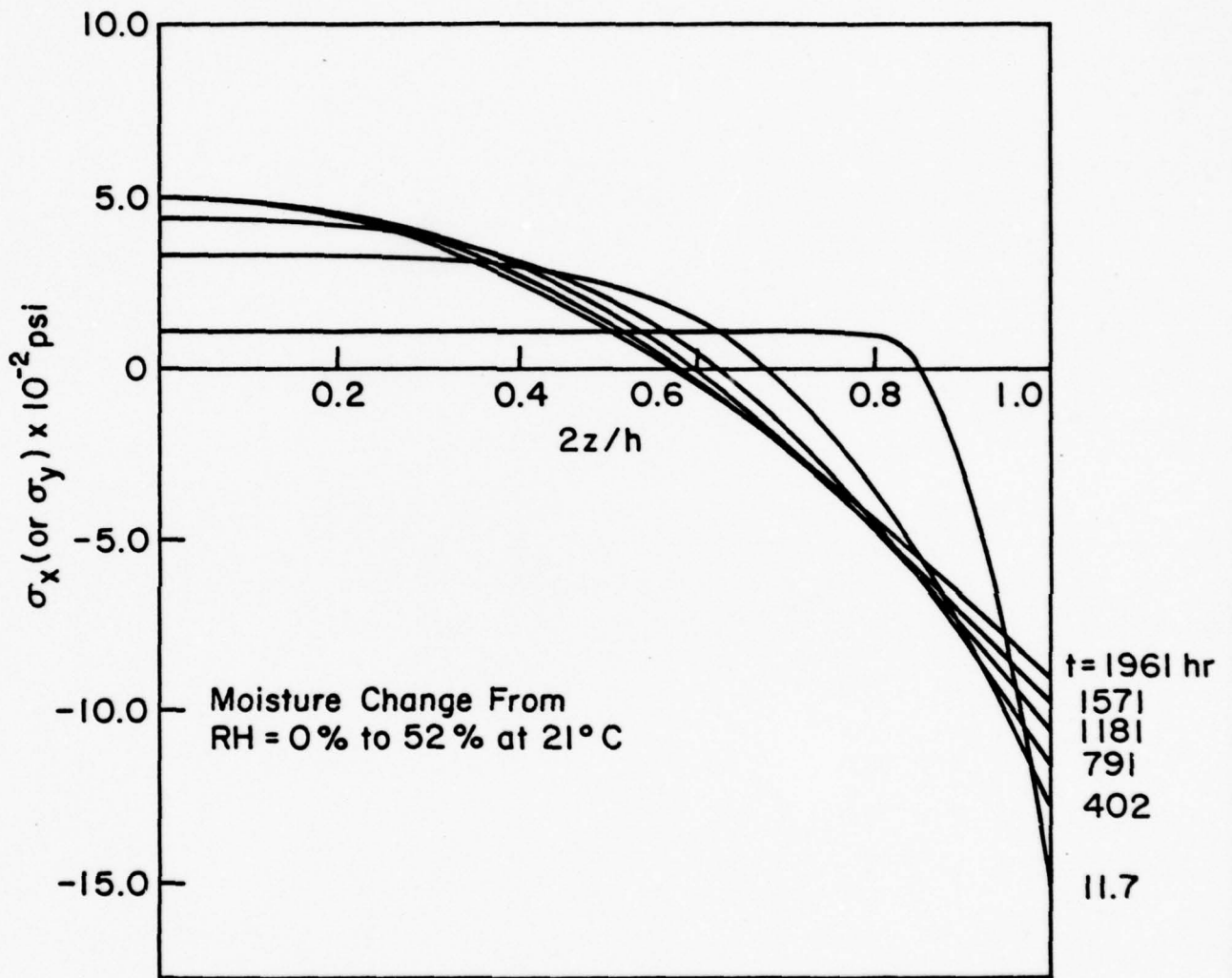

Figure 21 - Stress variations for $(RH)_f = 52\%$

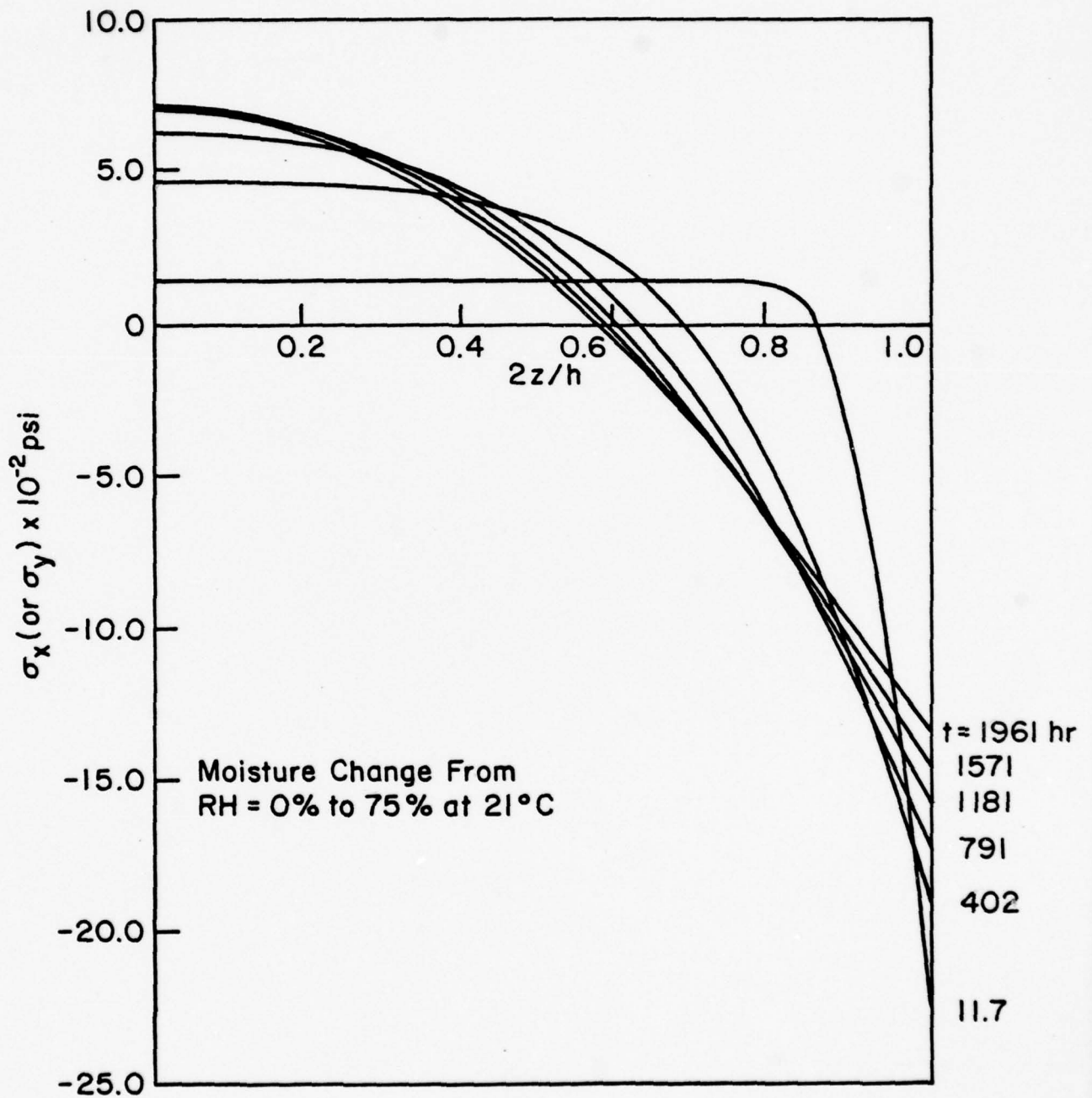

Figure 22 - Stress variations for $(RH)_f = 75\%$

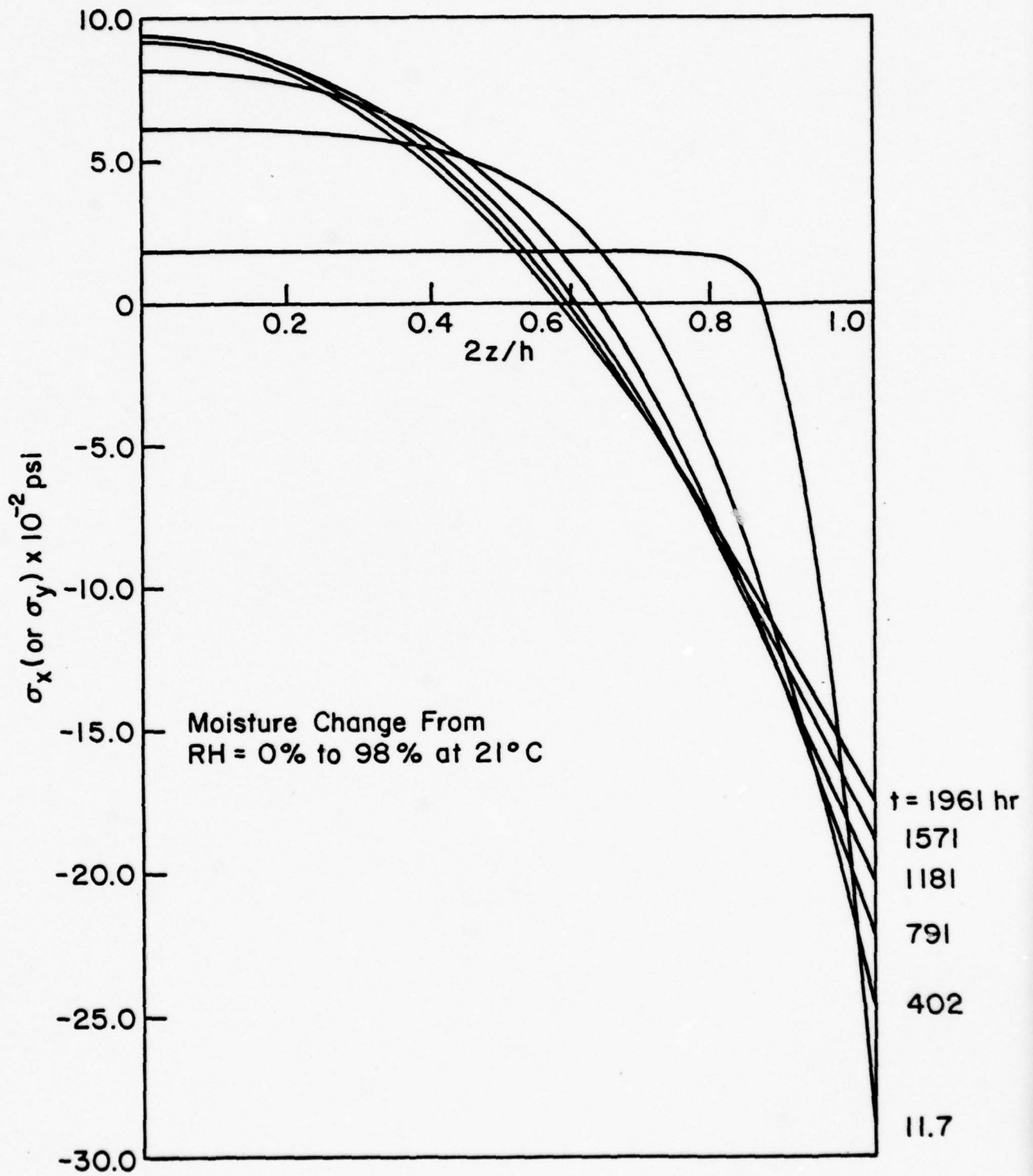

Figure 23 - Stress variations for $(RH)_f = 98\%$

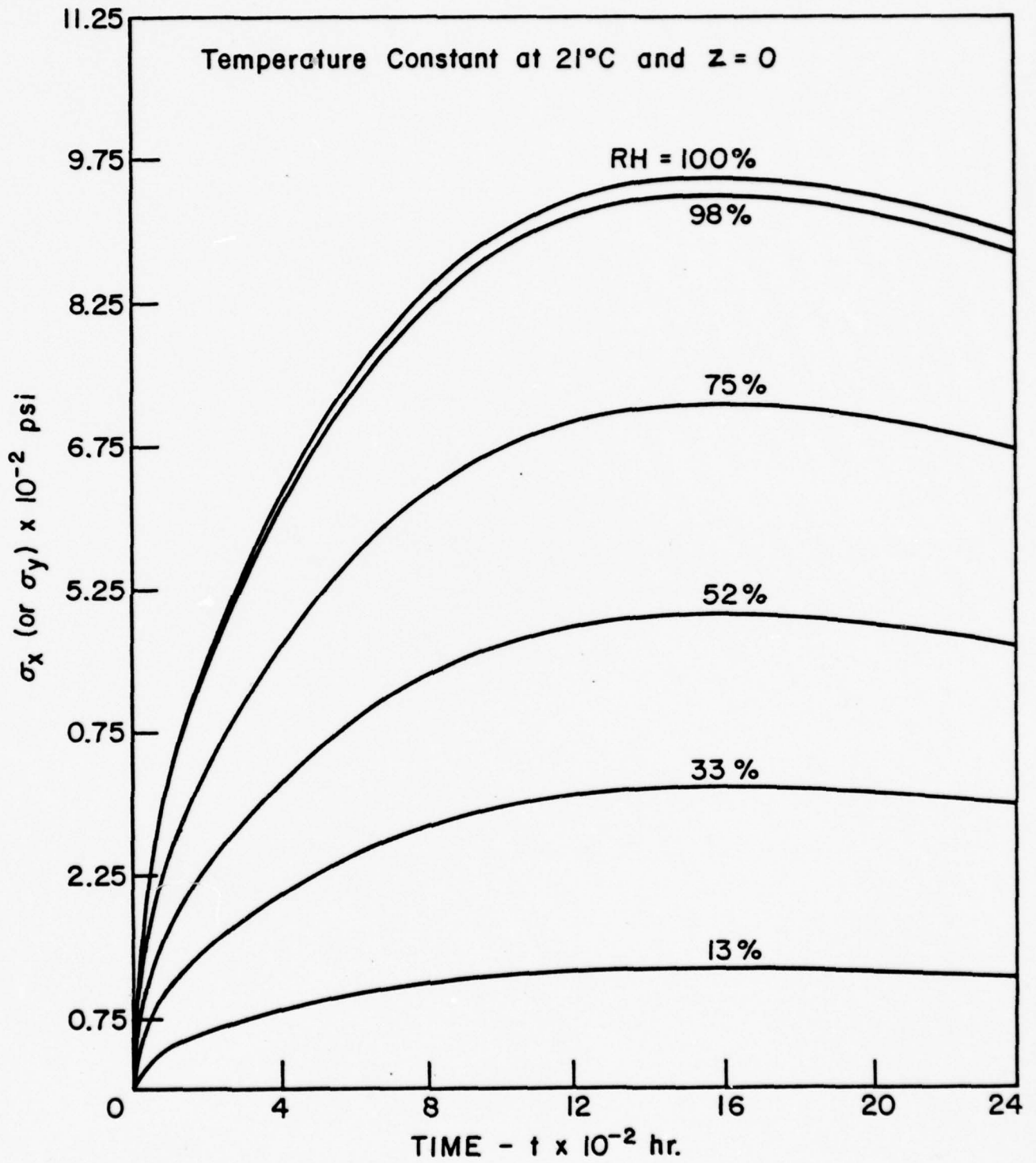

Figure 24 - Stress at midplane as a function of time

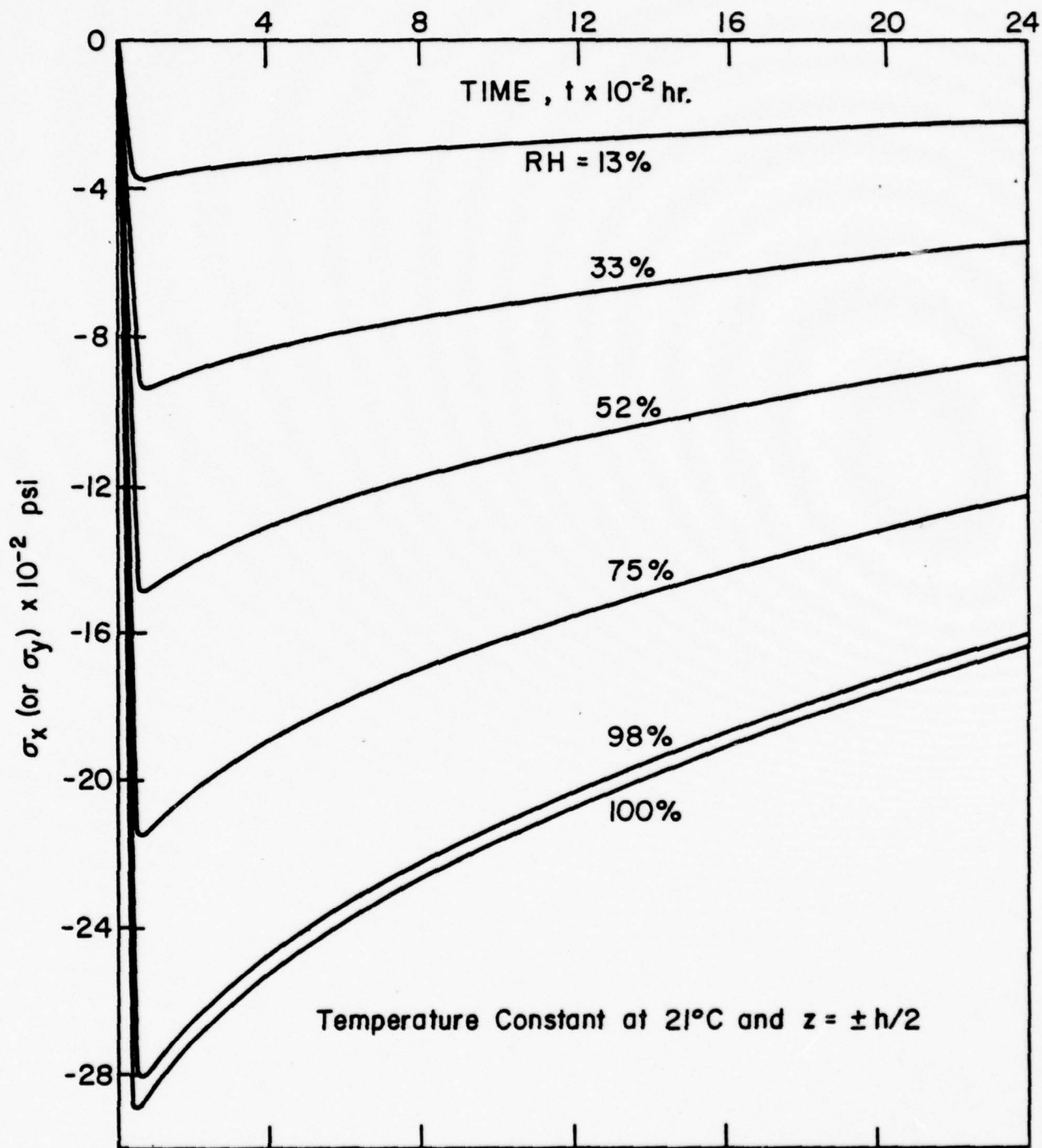

Figure 25 - Stress on plate surface as a function of time

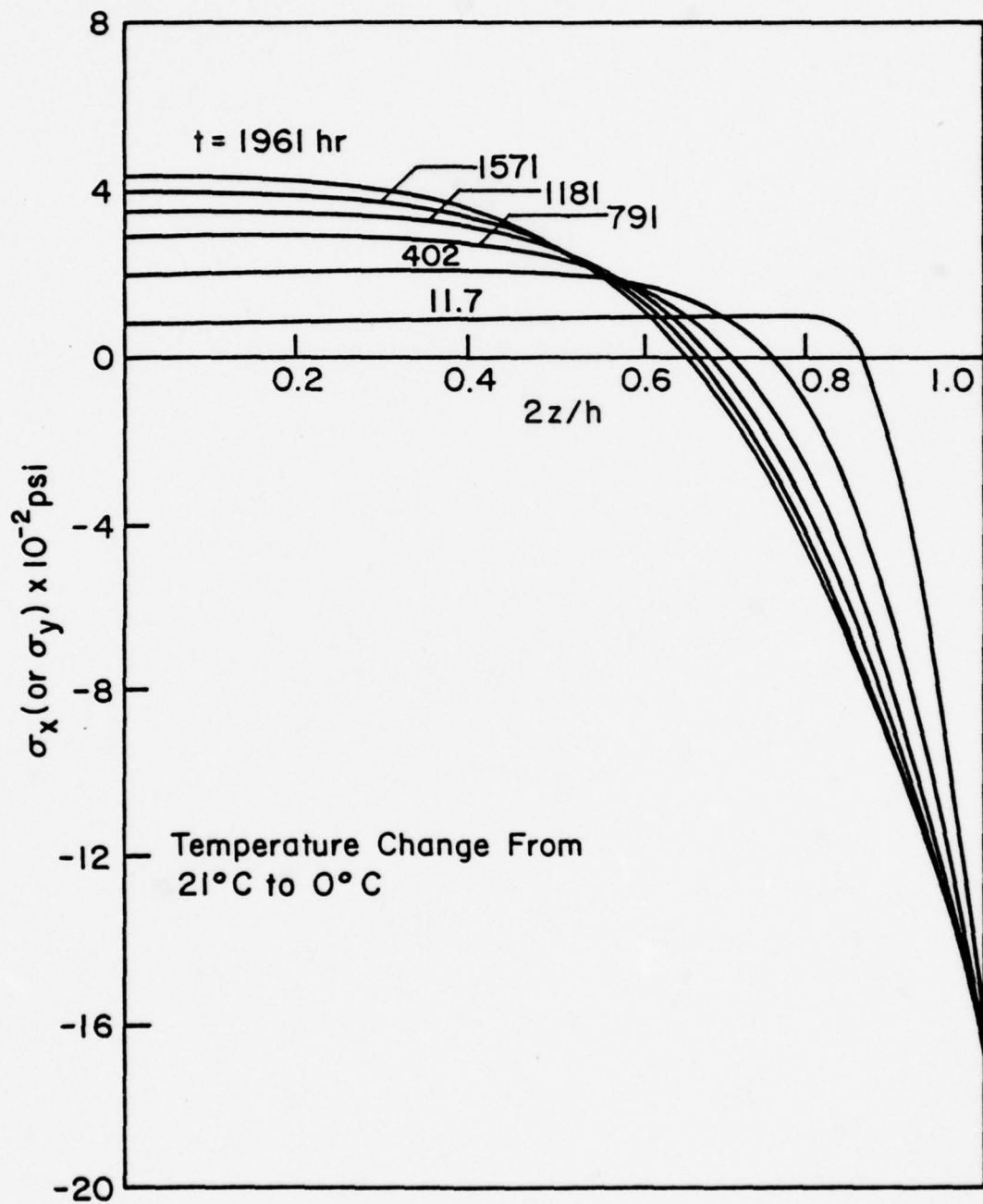

Figure 26 - Stress variations for temperature drop with $T_f = 0^\circ\text{C}$

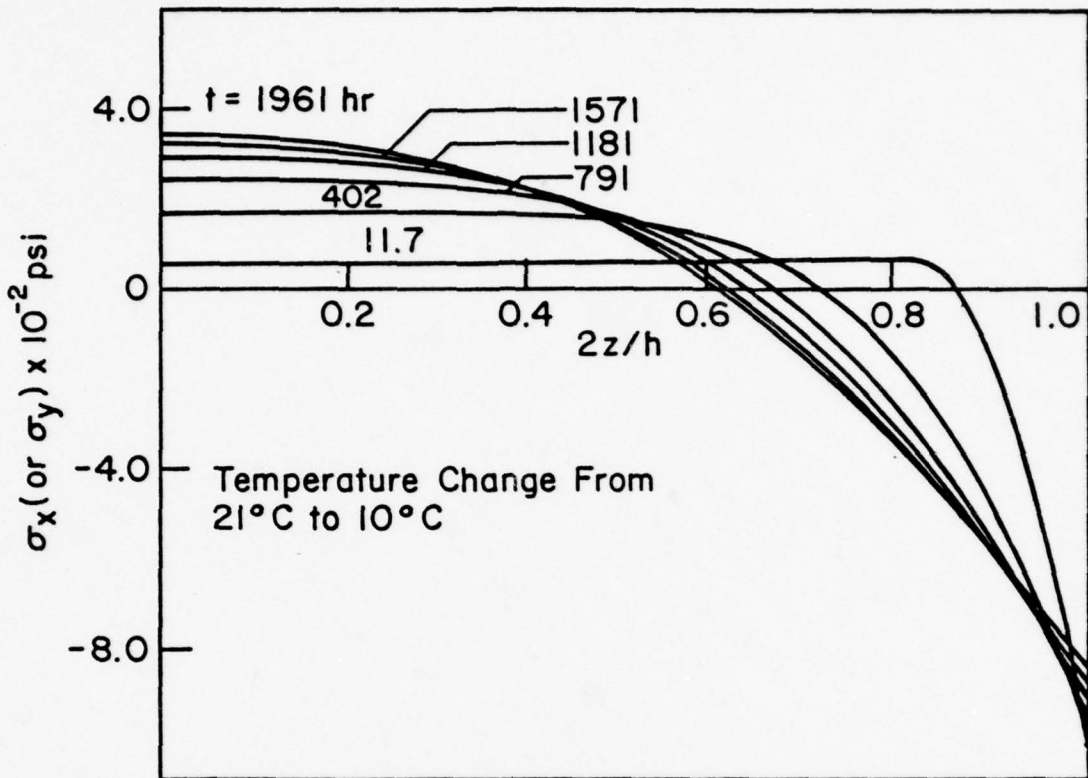

Figure 27 - Stress variations for temperature drop with $T_f = 10^\circ\text{C}$

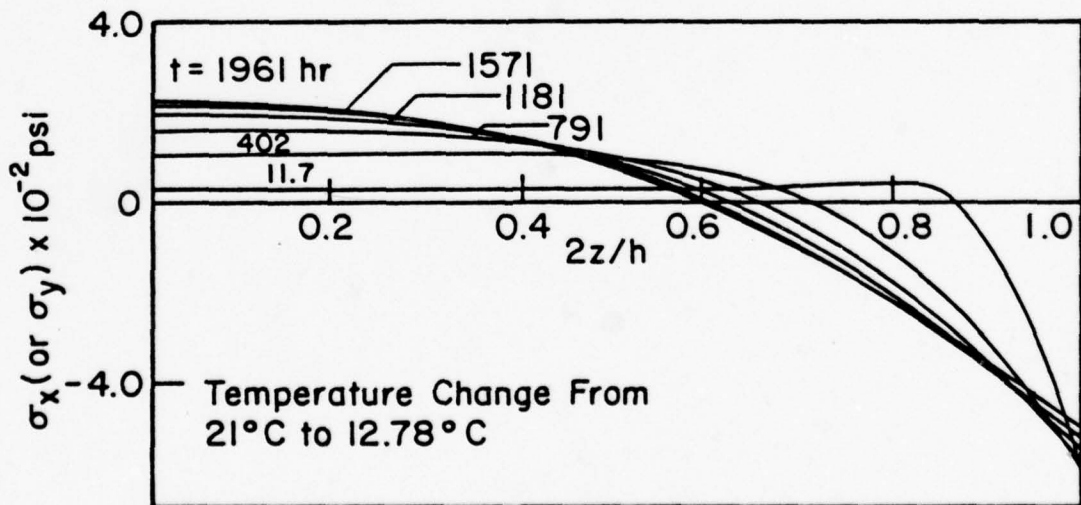

Figure 28 - Stress variations for temperature drop with $T_f = 12.78^\circ\text{C}$

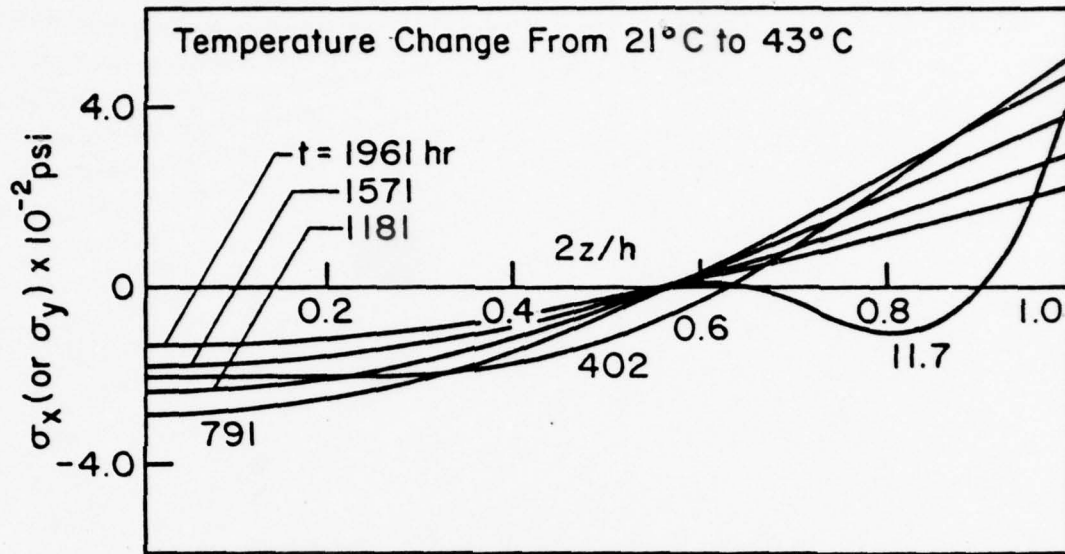

Figure 29 - Stress variations for temperature increase with $T_f = 43^\circ\text{C}$.

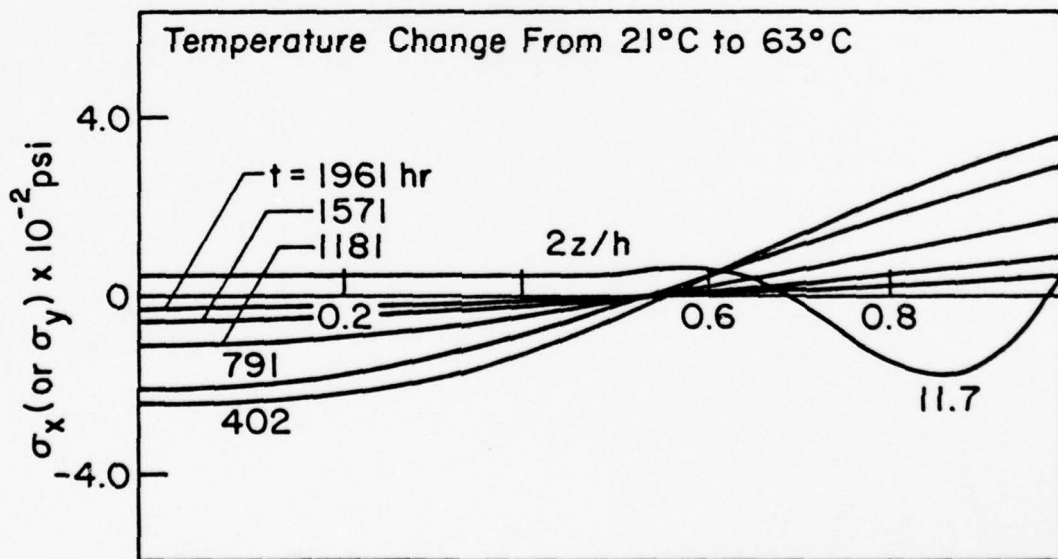

Figure 30 - Stress variations for temperature increase with $T_f = 63^\circ\text{C}$.

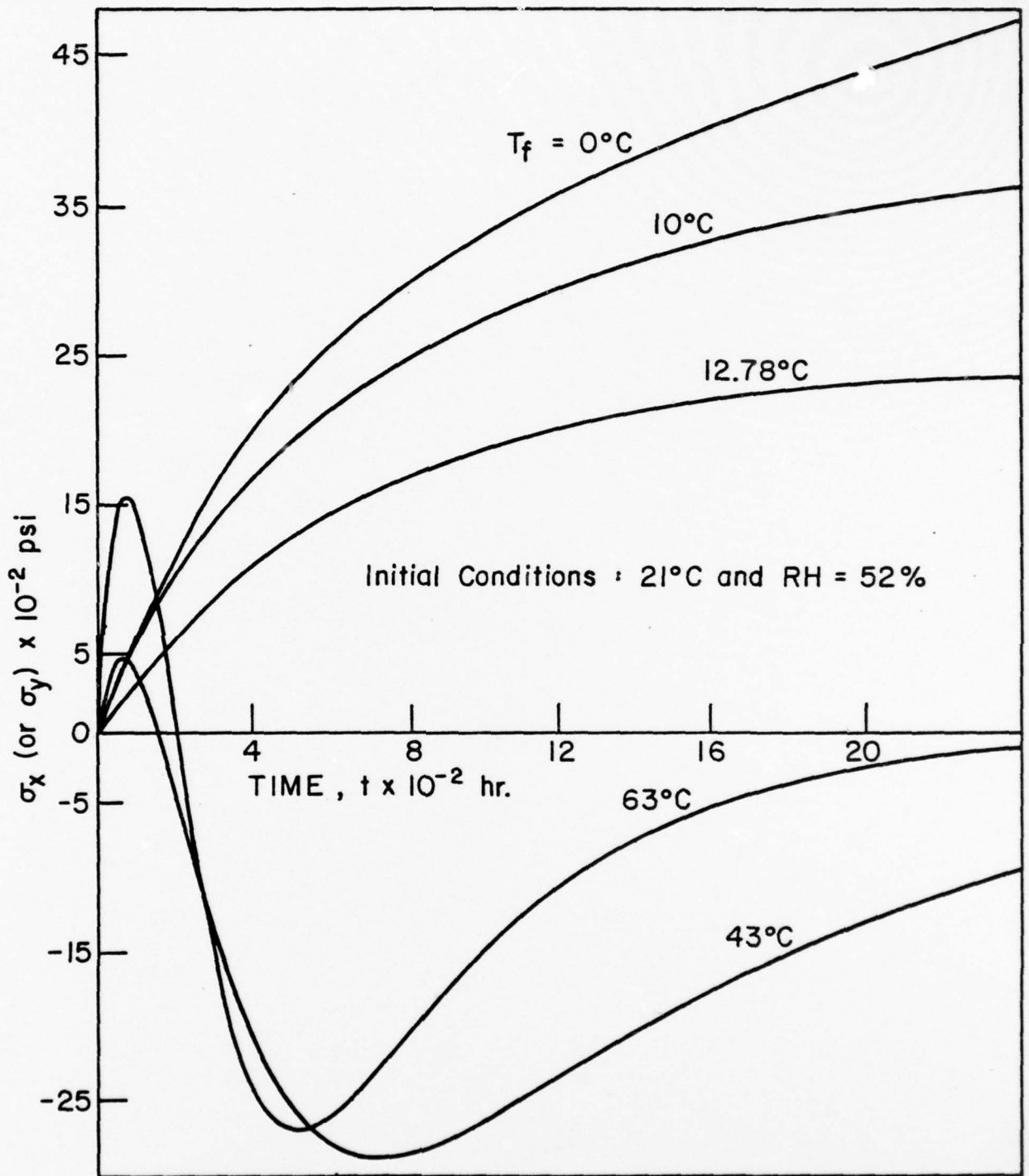

Figure 31 - Time dependent stress at the midplane due to different temperature gradients

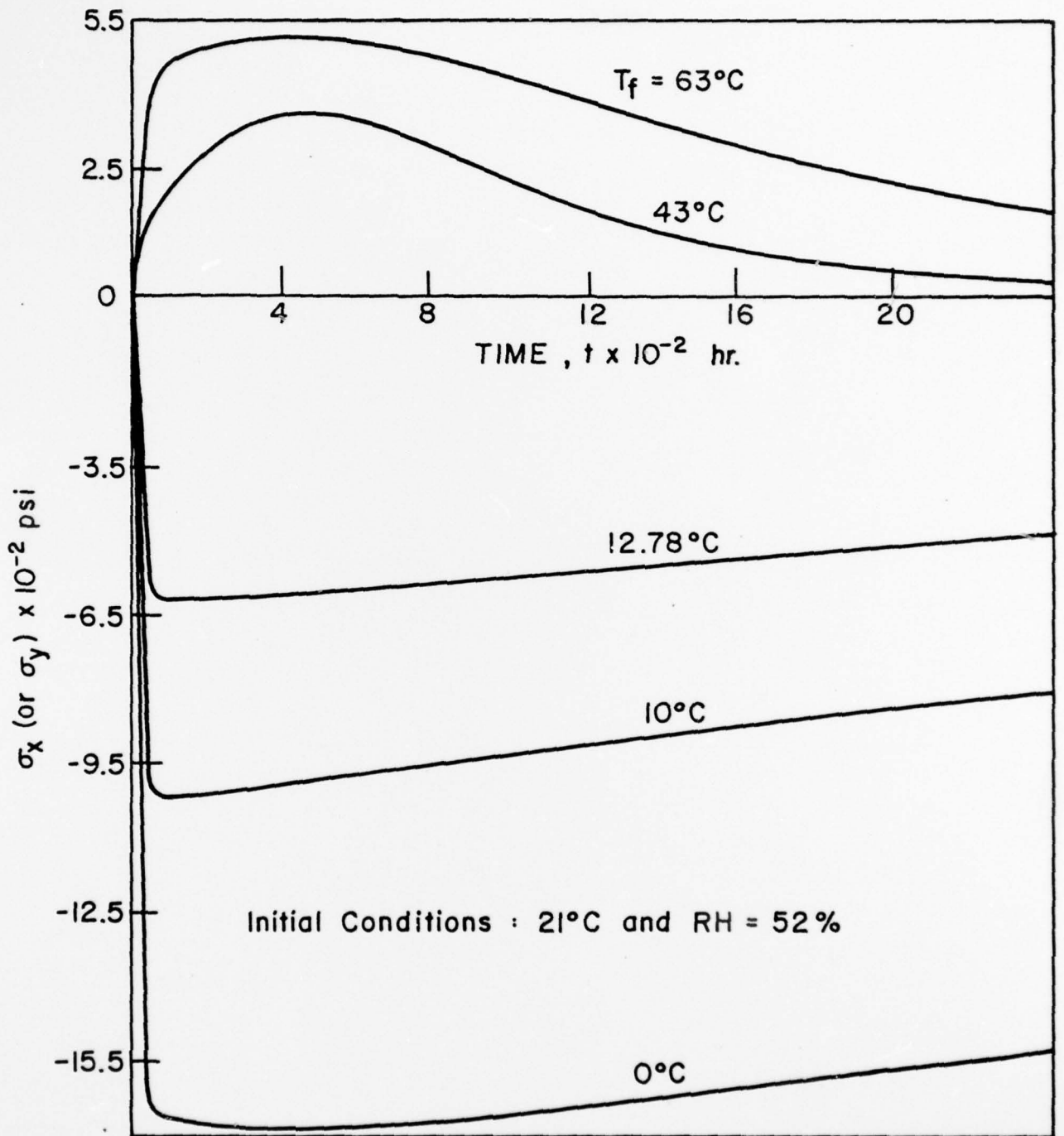

Figure 32 - Time dependent stresses on plate surface due to different temperature gradients

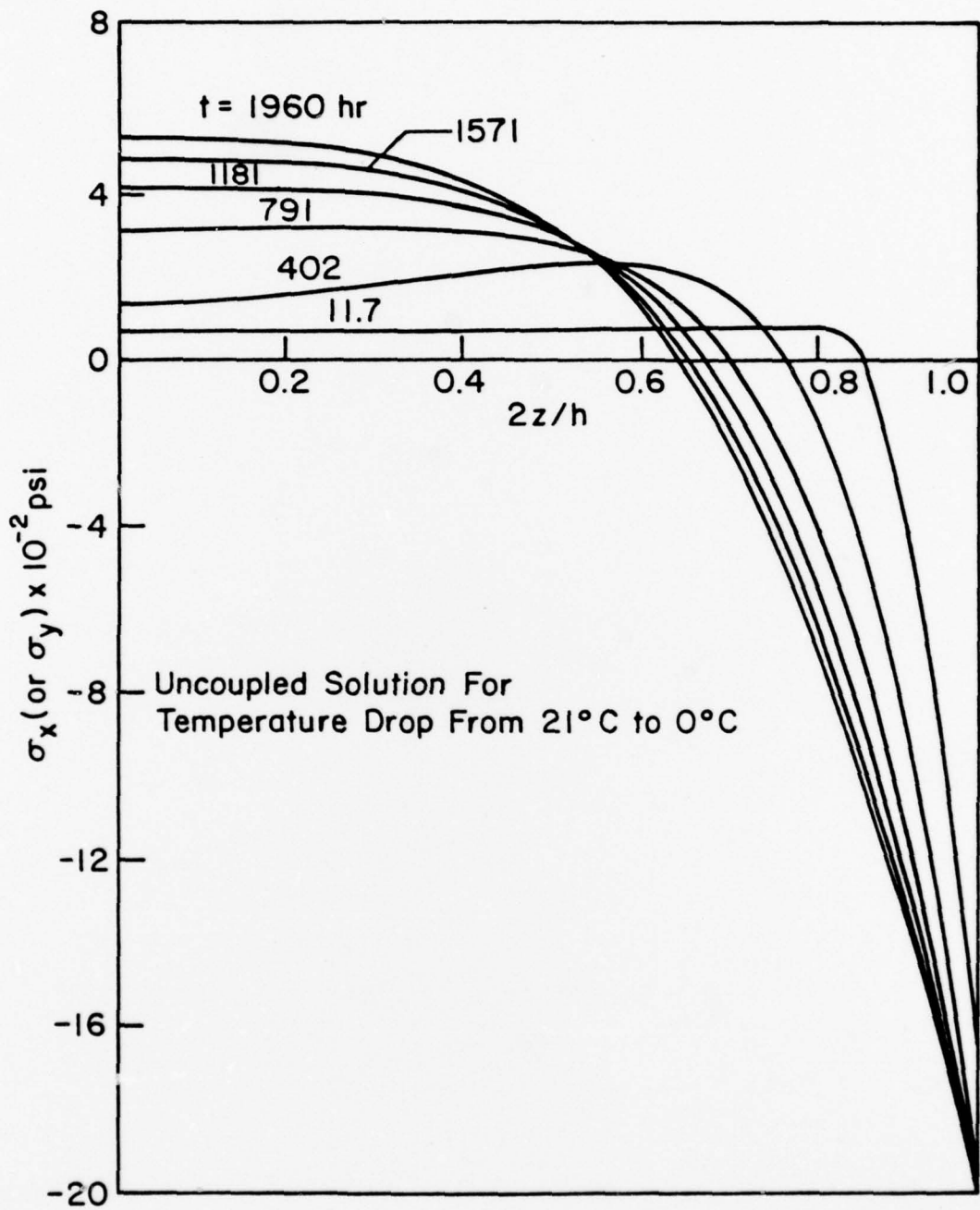

Figure 33 - Uncoupled stress solution for $\Delta T = -21^\circ\text{C}$

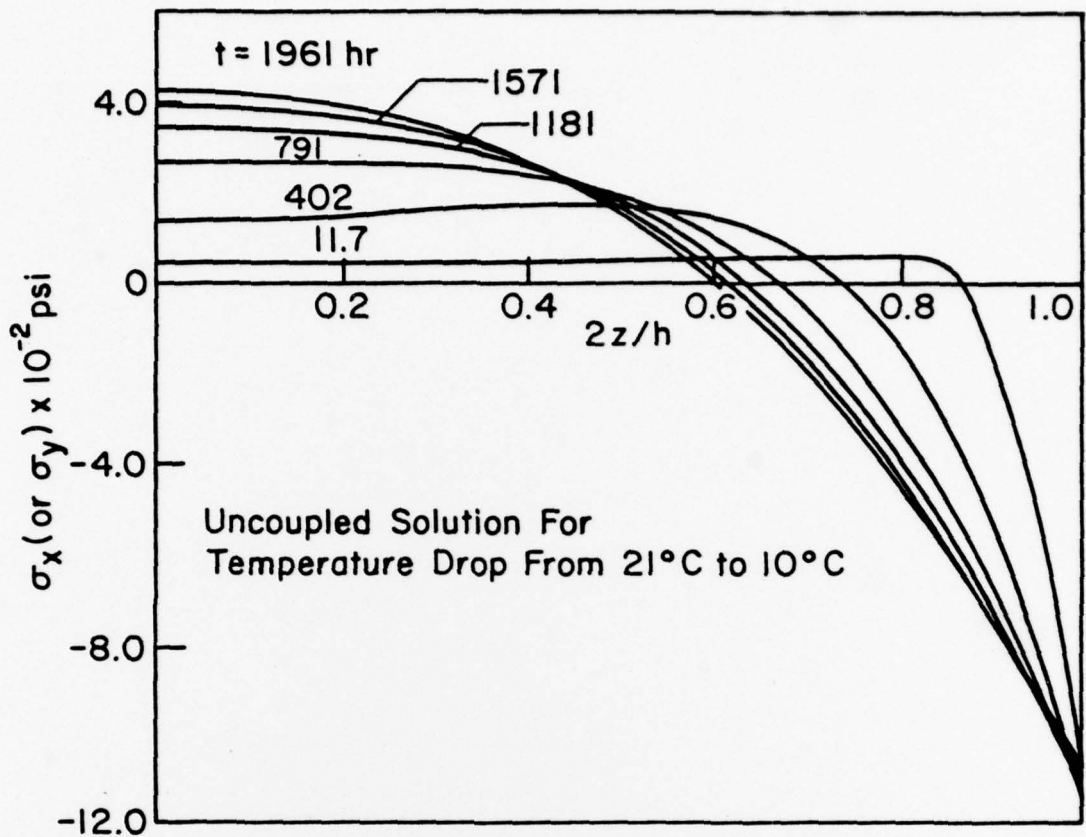

Figure 34 - Uncoupled stress solution for $\Delta T = -11^\circ\text{C}$

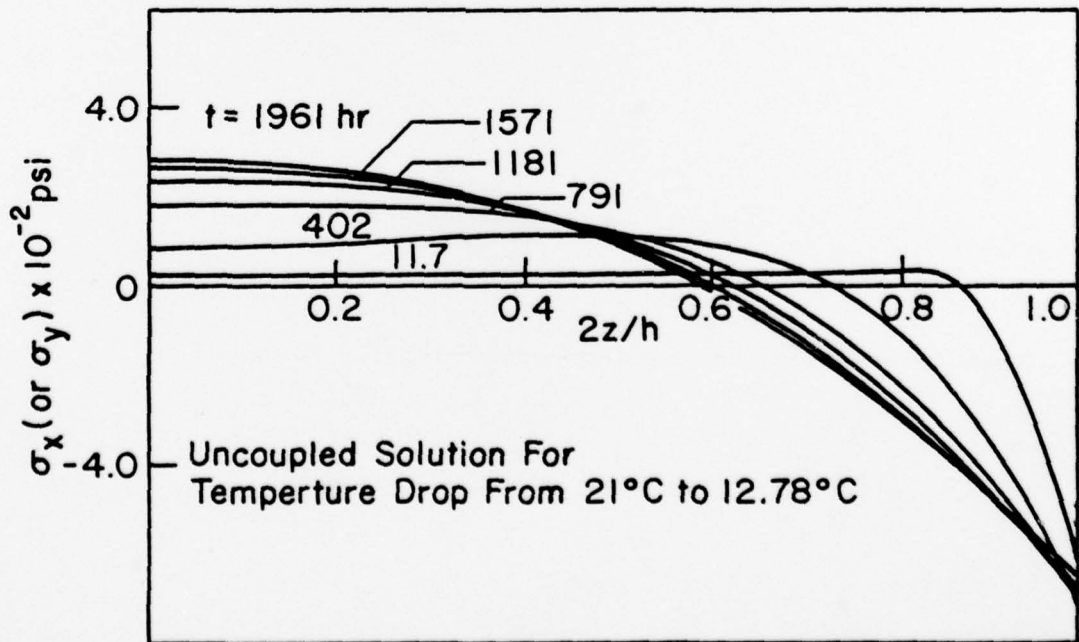

Figure 35 - Uncoupled stress solution for $\Delta T = -8.22^\circ\text{C}$

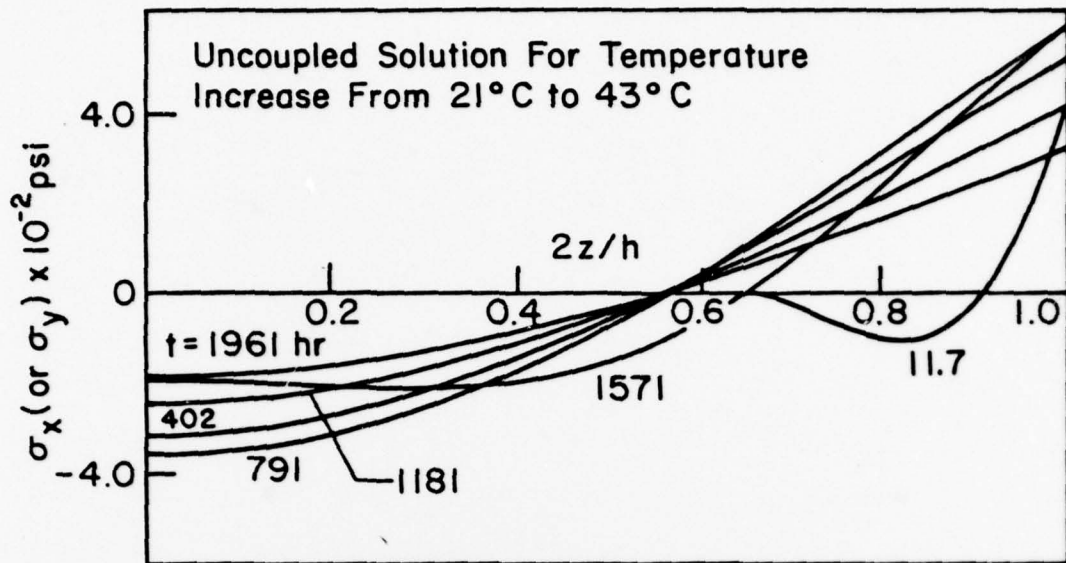

Figure 36 - Uncoupled stress solution for $\Delta T = 22^\circ\text{C}$

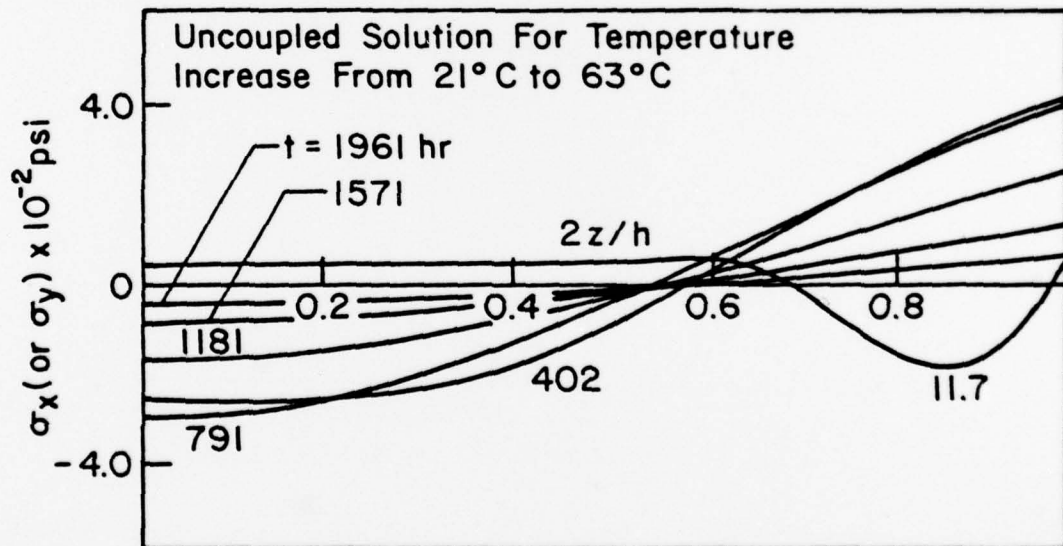

Figure 37 - Uncoupled stress solution for $\Delta T = 42^\circ\text{C}$

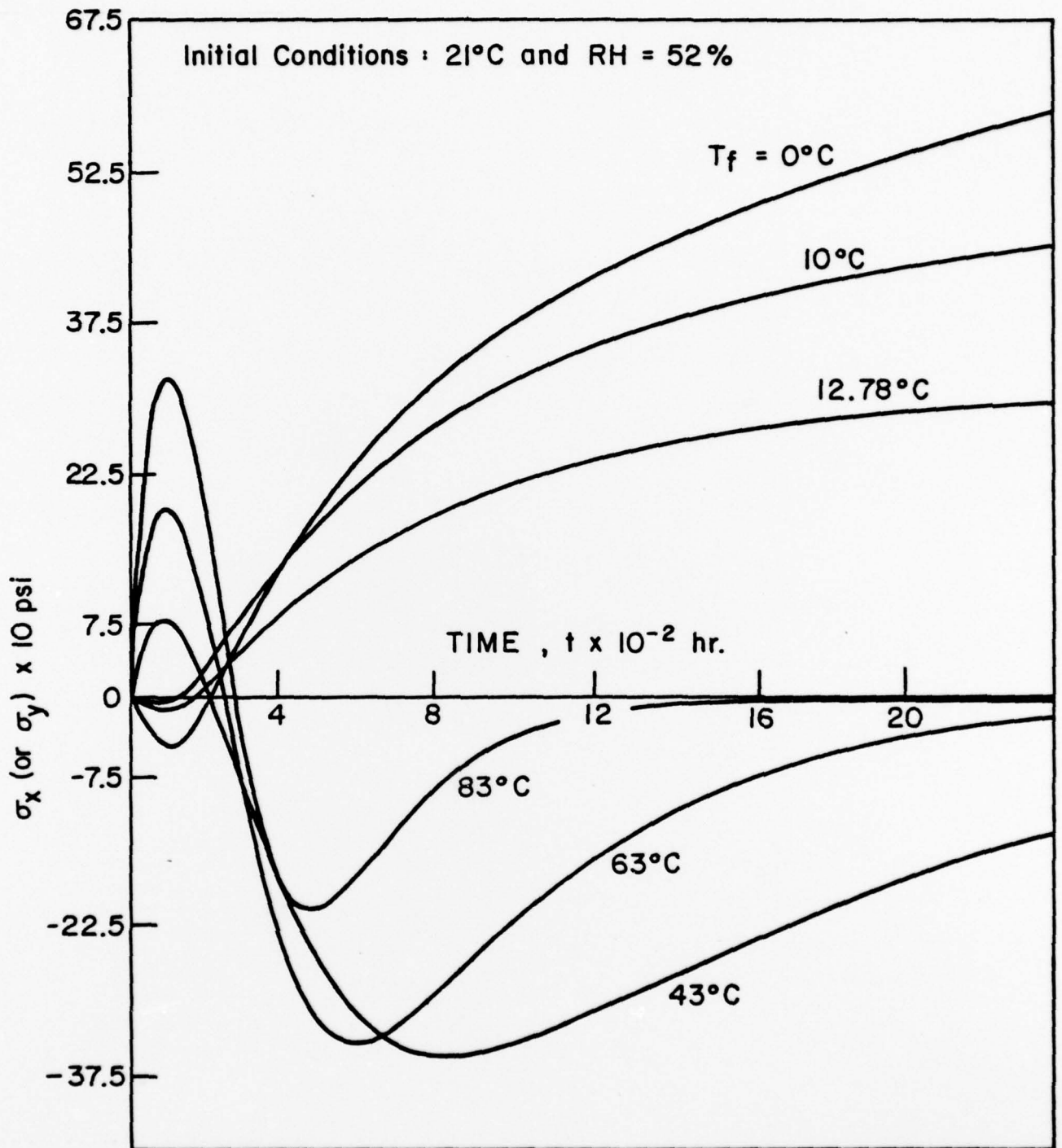

Figure 38 - Uncoupled stress solution at midplane due to different temperature gradients

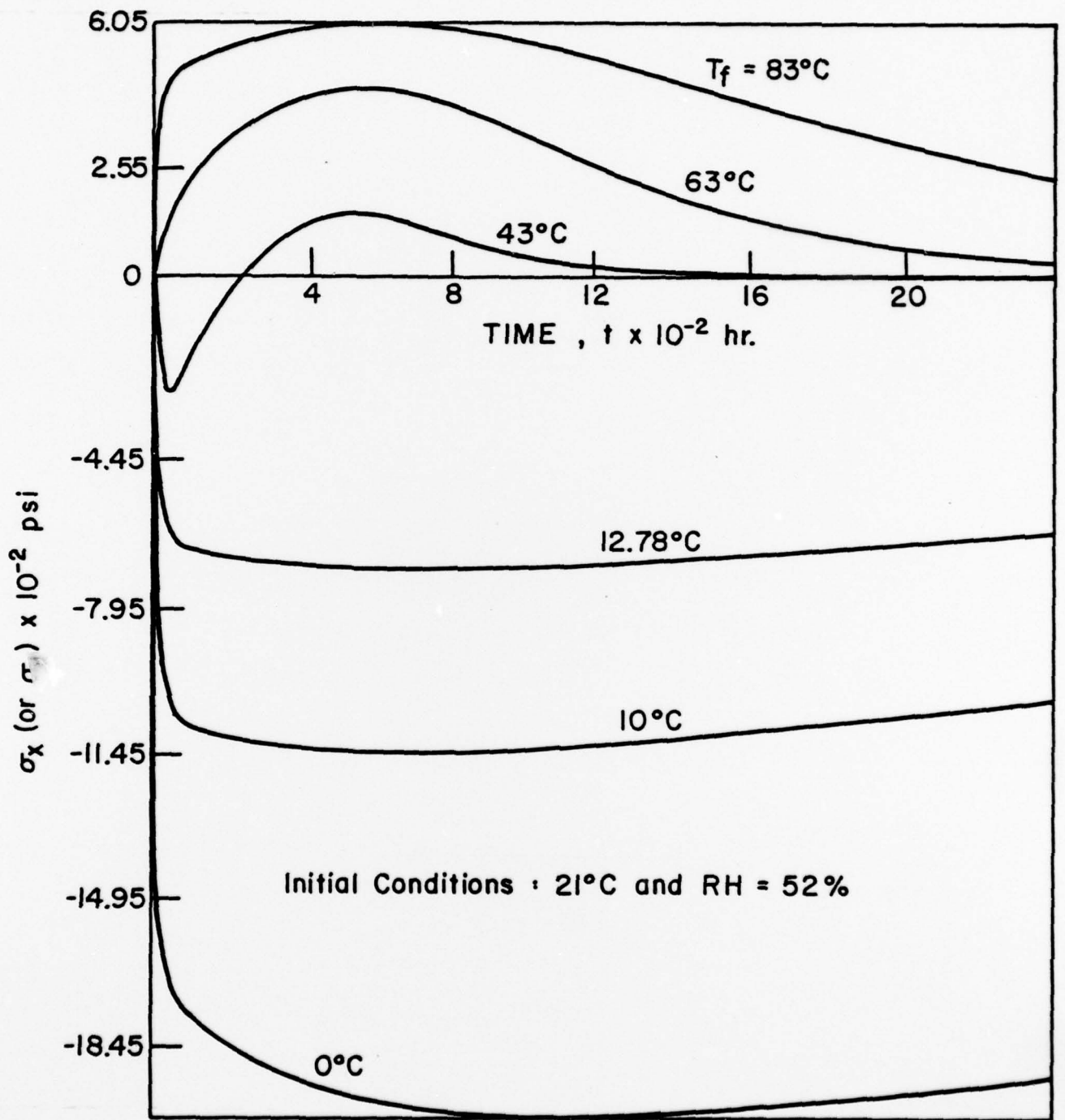

Figure 39 - Uncoupled stress solution on plate surface for different temperature gradients

DISTRIBUTION LIST

No. of Copies

Office of Deputy Under Secretary of Defense
for Research and Engineering (ET)
ATTN: Mr. J. Persh, Staff Specialist for Materials
and Structures (Room 3D1089) 1
The Pentagon
Washington, DC 20301

Office of Deputy Chief of Research Development
and Acquisition
ATTN: DAMA-CSS-D/Dr. J. I. Bryant (Room 3D424) 1
The Pentagon
Washington, DC 20310

Commander
U.S. Army Materiel Development and Readiness Command
ATTN: DRCLDC, Mr. R. J. Zentner 1
5001 Eisenhower Avenue
Alexandria, VA 22333

Director
Ballistic Missile Defense Systems Command
ATTN: BMDSC-TEN, Mr. N. J. Hurst 1
BMDSC-H 1
BMDSC-T 1
BMDSC-AOLIB 1
P. O. Box 1500
Huntsville, AL 35807

Ballistic Missile Defense Program Office
ATTN: DACS-BMT 1
DARCOM Bldg., Seventh Floor
5001 Eisenhower Avenue
Alexandria, VA 22333

Director
Ballistic Missile Defense Advanced Technology Center
ATTN: ATC-M, Mr. M. Whitfield 1
ATC-M, Dr. D. Harmon 1
ATC-M, Mr. J. Papadopoulos 1
P. O. Box 1500
Huntsville, AL 35807

No. of Copies

Director
Defense Nuclear Agency
ATTN: SPAS, Mr. J. F. Moulton, Jr. 1
SPAS, Mr. D. Kohler 1
Washington, DC 20305

Director
Army Ballistic Research Laboratories
ATTN: DRDAR-BLT, Dr. N. J. Huffington, Jr. 1
DRDAR-BLT, Dr. T. W. Wright 1
DRDAR-BLT, Dr. G. L. Moss 1
Aberdeen Proving Ground, MD 21005

Commander
Harry Diamond Laboratories
ATTN: DRXDO-NP, Dr. F. Wimenitz 1
2800 Powder Mill Road
Adelphi, MD 20783

Commander
U.S. Army Combat Development Command
Institute of Nuclear Studies
ATTN: Technical Library 1
Fort Bliss, Texas 79916

Commander
Air Force Materials Laboratory
Air Force Systems Command
ATTN: LNE/Dr. W. Kessler 1
LNC/Dr. D. Schmidt 1
Wright-Patterson Air Force Base, Ohio 45433

Space and Missile Systems Organization
ATTN: RSSE/LTC J. McCormack 2
P. O. Box 92960
World Way Postal Center
Los Angeles, CA 90009

Commander
Naval Ordnance Systems Command
ATTN: ORD-03331, Mr. M. Kinna 1
Washington, DC 20360

Commander
Naval Surface Weapons Center
ATTN: Dr. C. Lyons 1
Dr. W. Messick 1
Silver Springs, MD 20910

No. of Copies

Lawrence Livermore Laboratory ATTN: Dr. E. M. Wu P. O. Box 808 (L-342) Livermore, CA 94550	1
Los Alamos Scientific Laboratory ATTN: GMX-6, Dr. J. W. Taylor P. O. Box 1663 Los Alamos, NM 87544	1
Sandia Laboratories ATTN: Dr. Frank P. Garstle, Jr. Dr. L. D. Bertholf Dr. J. Lipkin P. O. Box 5800 Albuquerque, NM 87115	1 1 1
Aerospace Corporation ATTN: Dr. R. Cooper Dr. W. Barry P. O. Box 92957 Los Angeles, CA 90009	1 1
AVCO Corporation Government Products Group ATTN: Dr. W. Reinecke Mr. P. Rolincik 201 Lowell Street Wilmington, MA 01997	1 1
ETA Corporation ATTN: Mr. D. L. Mykkanen P. O. Box 6625 Orange, CA 92667	1
Effects Technology, Inc. ATTN: Dr. R. Wengler Dr. R. Parisse Mr. J. Green 5383 Hollister Avenue Santa Barbara, CA 93111	1 1 1
Fiber Materials, Inc. ATTN: Mr. M. Subilia, Jr. Mr. L. Landers Mr. G. Williams Mr. P. Marchol Biddeford Industrial Park Biddeford, ME 04005	1 1 1 1

No. of Copies

General Electric Company
Valley Forge Space Technology Center
ATTN: Mr. K. Hall 1
Mr. J. Brazel 1
Ms. B. McGuire 1
P. O. Box 8555
Philadelphia, PA 19101

General Dynamics Corporation
Convair Division
ATTN: Mr. J. Hertz 1
Mr. H. McCutcheon, Jr. 1
5001 Kearny Villa Road
San Diego, CA 92138

General Dynamics Corporation
ATTN: Dr. D. J. Wilkins 1
Mail Zone 2884
P. O. Box 748
Fort Worth, Texas 76101

Kaman Sciences Corporation
ATTN: Mr. F. Shelton 1
P. O. Box-7463
Colorado Springs, CO 80933

Ktech
ATTN: Dr. D. Keller 1
911 Pennsylvania Avenue, N.E.
Albuquerque, NM 87110

Lockheed Missiles and Space Company
ATTN: Mr. D. Aspinwall 1
P. O. Box 504
Sunnyvale, CA 94088

Martin Marietta Aerospace
ATTN: Dr. M. Hendricks 1
Mr. R. Hewitt 1
Mr. Frank H. Koo 1
P. O. Box 5837
Orlando, Florida 32805

McDonnell Douglas Corporation
ATTN: Dr. L. Cohen 1
Mr. H. Parachanian 1
5301 Bolsa Avenue
Huntington Beach, CA 92647

	<u>No. of Copies</u>
Prototype Development Associates, Inc. ATTN: Mr. J. Schultzler Mr. N. Harrington 1740 Garry Avenue, Suite 201 Santa Ana, CA 92705	1 1
R&D Associates ATTN: Dr. A. Field 525 Wilshire Blvd. Santa Monica, CA 90025	1
Radkowski Associates ATTN: Dr. P. Radkowski P. O. Box 5474 Riverside, CA 92507	1
Southwest Research Institute ATTN: Mr. A. Wenzel 8500 Culebra Road San Antonio, Texas 78206	1
Stanford Research Institute ATTN: Dr. D. Curran Dr. L. Seaman 333 Ravenswood Avenue Menlo Park, CA 90250	1 1
Terra Tek, Inc. ATTN: Dr. A. H. Jones 420 Wakara Way Salt Lake City, Utah 84108	1
TRW Systems Group ATTN: Mr. D. Gamble One Space Park Redondo Beach, CA 90278	1
Lehigh University Institute of Fracture and Solid Mechanics ATTN: Dr. George C. Sih Bldg. #19, Packard Lab. Bethlehem, PA 18015	1
Stanford University Department of Applied Mechanics ATTN: Professor E. H. Lee Stanford, CA 94305	1

No. of Copies

University of Illinois at Chicago Circle Department of Materials Engineering ATTN: Professor R. L. Spilker Chicago, Illinois 60680	1
Defense Documentation Center Cameron Station, Bldg. 5 5010 Duke Station Alexandria, VA 22314	1
Director Army Materials & Mechanics Research Center ATTN: DRXMR-H, Mr. J. F. Dignam	1
DRXMR-H, Mr. L. Aronin	1
DRXMR-H, Dr. S. C. Chou	1
DRXMR-H, Dr. D. Dandekar	1
DRXMR-AP	1
DRXMR-PL	2
DRXMR-PR	1
Watertown, MA 02172	

Army Materials and Mechanics Research Center,
Watertown, Massachusetts 02172
TRANSIENT HYDROTHERMAL STRESSES IN COMPOSITES:
COUPLING OF MOISTURE AND HEAT WITH TEMPERATURE
VARYING DIFFUSIVITY
G. C. Sih and M. T. Siah
Lehigh University, Bethlehem, Pennsylvania 18015

Army Materials and Mechanics Research Center,
Watertown, Massachusetts 02172
TRANSIENT HYDROTHERMAL STRESSES IN COMPOSITES:
COUPLING OF MOISTURE AND HEAT WITH TEMPERATURE
VARYING DIFFUSIVITY
G. C. Sih and M. T. Siah
Lehigh University, Bethlehem, Pennsylvania 18015

Final Report AMRC TR 79-14, March 1979, 46 pp.
illus - tables, Contract DAB04-78-C-0014

Final Report AMRC TR 79-14, March 1979, 46 pp.
illus - tables, Contract DAB04-78-C-0014

In this paper, the influence of coupled diffusion of heat and moisture on the transient stresses in a composite is investigated analytically where the moisture diffusion coefficient is taken to be temperature dependent while the thermal diffusion coefficient is assumed constant. The results show that each will obey the simple diffusion theory, particularly without reference made to the initial and boundary conditions by a finite-difference scheme allowing for time-dependent boundary conditions and specified on the surfaces of an infinite plate. Numerical calculations were carried out for the 1300/5208 graphite fiber-reinforced epoxy matrix composite in which the nonuniformity of moisture and temperature is evaluated for sudden changes in the surface moisture and/or temperature. The coupling effect of sudden changes in surface temperature while the surface moisture concentration is held constant. The present findings indicate that the stresses due to coupling can arise from the uncoupled results anywhere from 20 to 90 percent depending on the surface temperature gradient. The present findings also provide additional experimental means for evaluating the coupled diffusion phenomenon and its influence on the mechanical behavior of epoxy-resin-composites.

In this paper, the influence of coupled diffusion of heat and moisture on the transient stresses in a composite is investigated analytically where the moisture diffusion coefficient is taken to be temperature dependent while the thermal diffusion coefficient is assumed constant. The results show that each will obey the simple diffusion theory, particularly without reference made to the initial and boundary conditions by a finite-difference scheme allowing for time-dependent boundary conditions and specified on the surfaces of an infinite plate. Numerical calculations were carried out for the 1300/5208 graphite fiber-reinforced epoxy matrix composite in which the nonuniformity of moisture and temperature is evaluated for sudden changes in the surface moisture and/or temperature. The coupling effect of sudden changes in surface temperature while the surface moisture concentration is held constant. The present findings indicate that the stresses due to coupling can arise from the uncoupled results anywhere from 20 to 90 percent depending on the surface temperature gradient. The present findings also provide additional experimental means for evaluating the coupled diffusion phenomenon and its influence on the mechanical behavior of epoxy-resin-composites.

Key words
Composites
Moisture content
Thermal diffusivity
Thermal stresses
Temperature
Temperature gradient
Hydrothermal effect

Key words
Composites
Moisture content
Thermal diffusivity
Thermal stresses
Temperature
Temperature gradient
Hydrothermal effect

UNCLASSIFIED
UNLIMITED DISTRIBUTION

UNCLASSIFIED
UNLIMITED DISTRIBUTION

Army Materials and Mechanics Research Center,
Watertown, Massachusetts 02172
TRANSIENT HYDROTHERMAL STRESSES IN COMPOSITES:
COUPLING OF MOISTURE AND HEAT WITH TEMPERATURE
VARYING DIFFUSIVITY
G. C. Sih and M. T. Siah
Lehigh University, Bethlehem, Pennsylvania 18015

Army Materials and Mechanics Research Center,
Watertown, Massachusetts 02172
TRANSIENT HYDROTHERMAL STRESSES IN COMPOSITES:
COUPLING OF MOISTURE AND HEAT WITH TEMPERATURE
VARYING DIFFUSIVITY
G. C. Sih and M. T. Siah
Lehigh University, Bethlehem, Pennsylvania 18015

Final Report AMRC TR 79-14, March 1979, 46 pp.
illus - tables, Contract DAB04-78-C-0014

Final Report AMRC TR 79-14, March 1979, 46 pp.
illus - tables, Contract DAB04-78-C-0014

In this paper, the influence of coupled diffusion of heat and moisture on the transient stresses in a composite is investigated analytically where the moisture diffusion coefficient is taken to be temperature dependent while the thermal diffusion coefficient is kept constant. There is no a priori reason why moisture and temperature should be uncoupled such that each will obey the simple diffusion theory, particularly without reference made to the initial and boundary conditions by a finite-difference scheme allowing for time-dependent changes in the humidity and temperature of the environment. The appropriate transient boundary conditions are specified on the surfaces of an infinite plate. Numerical calculations were carried out for the 1300/5208 graphite fiber-reinforced epoxy matrix composite in which the nonuniformity of moisture and temperature is evaluated for sudden changes in the surface moisture and/or temperature. The coupling effect between temperature and moisture is found to be most significant when the plate undergoes a sudden change in surface temperature while the surface moisture concentration is held constant. The present findings indicate that the stresses due to coupling can arise from the uncoupled results anywhere from 20 to 90 percent depending on the surface temperature gradient. This suggests the need to perform additional experiments for evaluating the coupled diffusion phenomenon and its influence on the mechanical behavior of epoxy-resin-composites.

In this paper, the influence of coupled diffusion of heat and moisture on the transient stresses in a composite is investigated analytically where the moisture diffusion coefficient is taken to be temperature dependent while the thermal diffusion coefficient is kept constant. There is no a priori reason why moisture and temperature should be uncoupled such that each will obey the simple diffusion theory, particularly without reference made to the initial and boundary conditions by a finite-difference scheme allowing for time-dependent changes in the humidity and temperature of the environment. The appropriate transient boundary conditions are specified on the surfaces of an infinite plate. Numerical calculations were carried out for the 1300/5208 graphite fiber-reinforced epoxy matrix composite in which the nonuniformity of moisture and temperature is evaluated for sudden changes in the surface moisture and/or temperature. The coupling effect between temperature and moisture is found to be most significant when the plate undergoes a sudden change in surface temperature while the surface moisture concentration is held constant. The present findings indicate that the stresses due to coupling can arise from the uncoupled results anywhere from 20 to 90 percent depending on the surface temperature gradient. This suggests the need to perform additional experiments for evaluating the coupled diffusion phenomenon and its influence on the mechanical behavior of epoxy-resin-composites.