

AD-A072 717

DEFENCE RESEARCH ESTABLISHMENT ATLANTIC DARTMOUTH (NO--ETC F/G 13/10
ON THE APPLICATION OF MODERN CONTROL THEORY TO SHIP ROLL STABIL--ETC(U)
MAR 79 P H WHYTE

UNCLASSIFIED

DREA-79/2

NL

| OF |
ADA
072717



END
DATE
FILMED
9-79
DDC

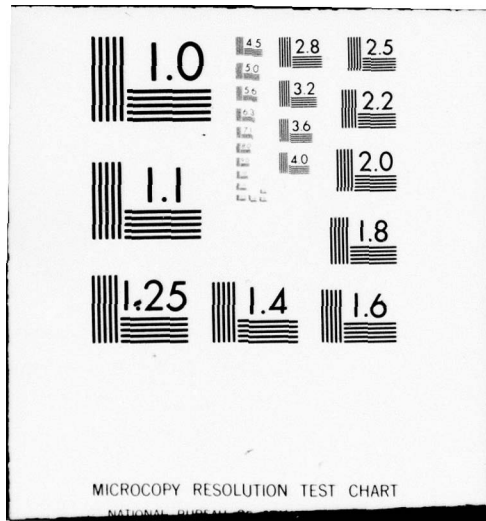

ON THE APPLICATION
OF MODERN CONTROL THEORY
TO SHIP ROLL STABILISATION

DDC
RECEIVED
AUG 14 1979
D

D.R.E.A. REPORT 79/2

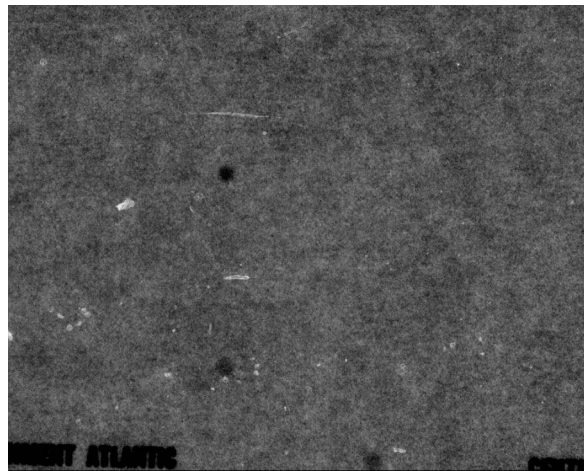

DEFENCE RESEARCH ESTABLISHMENT
ATLANTIC
DARTMOUTH N.S.

D.R.E.A. REPORT 79/2

14 DREA-79/2

6 ON THE APPLICATION
OF MODERN CONTROL THEORY
TO SHIP ROLL STABILISATION.

10 P. H. Whyte

11 March 1979

12 34 p.

Approved by T. GARRETT Director / Underwater Acoustics Division

DISTRIBUTION APPROVED BY

Jac. Ferguson

CHIEF D.R.E.A.

RESEARCH AND DEVELOPMENT BRANCH
DEPARTMENT OF NATIONAL DEFENCE
CANADA

DDC
RECEIVED
AUG 14 1979
REGULATED

403 761
79 08 13 002

mtx

DEFENCE RESEARCH ESTABLISHMENT
ATLANTIC
DARTMOUTH NS
DATE & REPORT TYPE

ABSTRACT

The high feedback gains employed by current active roll stabilisation systems result in control surface cavitation and excessive machinery activity, both of which contribute significantly to the noise radiated by the ship. In the case of warships, this noise is most undesirable. To circumvent this difficulty, a reduced noise mode of operation is proposed for use in a threat situation. This reduced noise mode is characterised by little or no cavitation and low levels of machinery wear.

A design procedure incorporating modern control theory as the major tool in the selection of feedback gains for ship roll stabilisation is presented. The procedure is applied to the reduced noise mode, but may be readily adapted to controller design for other modes of operation. With this technique, the designer is able to minimise a performance index which is a function of both roll angle and fin angle, while keeping fin motions below the cavitation limit. Application to an example ship configuration employing fin, rudder or combined fin-rudder control is considered. The closed loop performance of these systems is simulated and the results demonstrate the power of modern control theory in this application.

Accession For	
NTIS GRA&I	<input checked="" type="checkbox"/>
DDC TAB	<input type="checkbox"/>
Unannounced	<input type="checkbox"/>
Justification	
By _____	
Distribution/	
Availability Codes	
Dist.	Avail and/or special
A	

SOMMAIRE

Les gains de rétroaction élevés qu'utilisent les systèmes actuels de stabilisation active du roulis entraînent une cavitation de surface de contrôle et une activité excessive des machines, soit deux éléments qui contribuent de façon sensible au bruit qui irradie du navire. Dans le cas des navires de guerre, ce bruit est des plus indésirables. Pour contourner cette difficulté, on propose un mode de fonctionnement à bruit réduit, à utiliser dans une situation de menace. Ce mode de fonctionnement à bruit réduit produit peu ou pas de cavitation et peu d'usure des machines.

On présente une procédure de conception qui incorpore la théorie de contrôle moderne comme instrument principal de la sélection des gains de rétroaction pour la stabilisation du roulis des navires. La procédure est appliquée au mode de fonctionnement à bruit réduit, mais elle peut être facilement adaptée au modèle du contrôleur pour d'autres modes de fonctionnement. Grâce à cette technique, le concepteur est en mesure de réduire un indice de rendement qui dépend à la fois de l'angle de roulis et de l'angle d'aileron, tout en faisant en sorte que les mouvements d'aileron ne dépassent pas la limite de cavitation. On étudie l'application à une configuration modèle de navire utilisant le contrôle d'aileron, le contrôle de gouvernail ou le contrôle combiné aileron-gouvernail. On simule le rendement en circuit fermé de ces systèmes et les résultats démontrent la capacité de la théorie moderne de contrôle dans cette application.

TABLE OF CONTENTS

	<u>Page No.</u>
ABSTRACT	i
NOTATION	v
1. INTRODUCTION	1
2. MATHEMATICAL FORMULATION	2
3. MODERN CONTROL THEORY	5
3.1 COMPLETE STATE FEEDBACK	5
3.2 OUTPUT FEEDBACK	7
4. ACTIVE FIN STABILISER DESIGN	8
5. ACTIVE RUDDER STABILISER DESIGN	11
6. THE PERFORMANCE OF SINGLE INPUT SYSTEMS	11
7. COMBINED FIN-RUDDER CONTROL	12
8. CONCLUDING REMARKS	15
TABLES	17
ILLUSTRATIONS	18
REFERENCES	25
DOCUMENT CONTROL DATA	27

NOTATION

A	system matrix
A_{ij}	added mass coefficient
A_{CL}	closed loop system matrix
B	input matrix
B_{ij}	damping coefficient
C	output matrix
C_{ij}	stiffness coefficient
E	statistical expectation
F	output feedback gain matrix
F_j	exciting force
G	state feedback gain matrix
H	solution to Lyapunov equation
I_j	moment of inertia
J	performance index
K	solution to Riccati equation
L	solution to Lyapunov equation
Q	state weighting matrix
Q_1	$Q_1'Q_1 = Q$
R	input weighting matrix
U	ship speed
m	ship mass
t	time
u	input vector
x	state vector
y	output vector

η_2	sway displacement
η_4	roll angle
η_6	yaw angle
δ	rudder angle
β	fin angle
ζ_δ	rudder actuator damping ratio
ζ_β	fin actuator damping ratio
ω_δ	rudder actuator natural frequency
ω_β	fin actuator natural frequency
μ, μ_1, μ_2	weighting factors in J
$(\dot{})$	first time derivative
$(\ddot{})$	second time derivative
$(\)_c$	command input
$(\)'$	matrix transpose
$(\)^{-1}$	matrix inverse
$(\)^*$	optimal feedback gain matrix

1. INTRODUCTION

The need for roll stabilisation of a ship in a seaway can be predicted during the early stages of design with recently developed analytical techniques¹. If the ship lacks the necessary degree of inherent roll stability, a means of roll reduction must be provided, such as stabilization tanks or active feedback control fins. In addition to these devices, recent experimental work² has successfully demonstrated the use of active rudder control in reducing ship roll. However, the ability of conventional rudder servomechanisms to cope reliably with the additional activity throughout the service life of the ship will have to be established before this technique will gain acceptance.

Active roll stabilisation devices, as currently implemented, have some disadvantages. The most significant disadvantage, with respect to military applications, is the high level of radiated noise attributable to the operation of an active system. The high feedback gains typical of present installations force the control surfaces to operate in a 'bang-bang' mode so that they are continuously cavitating. Cavitation generates high levels of hydrodynamic flow noise. In addition, such activity exposes the mechanism to excessive wear and tear, with a consequent degradation in reliability and increase in machinery noise. These undesirable features can be reduced, while still maintaining good roll stabilization, through the judicious use of modern control theory.

Modern control theory has only recently been applied in the field of ship dynamics, stability and control. In the case of advanced marine vehicles, Hsu³ has applied the technique to the design of a control system for the longitudinal motions of a hydrofoil ship, and the author⁴ has employed modern control theory for the control of hydrofoil ship lateral motions. Other papers^{5,6} have been concerned with control systems for conventional displacement ships. This Report will demonstrate the use of modern control theory in the design of active control systems for fin, rudder and combined fin-rudder roll stabilisers for a ship at constant speed in beam seas.

Two modes of operation are envisaged. The first, the reduced noise mode, would be used when the ship is in a threat situation. In this mode, the motions of the control surfaces

are kept below their cavitation limits. This approach reduces both machinery and flow noise. The second mode of operation is called the normal mode, and it would be used at all other times. In this mode, the restrictions on control surface activity would be less severe than for the reduced noise mode, so that more roll reduction could be obtained than with the reduced noise mode. However, the normal mode would not employ 'bang-bang' control, thus avoiding some of the problems associated with that approach.

Although modern control theory is applicable to both modes of operation, only the reduced noise mode will be considered in this Report. Given a fixed level of control surface activity, the designer strives to choose feedback gains which minimize rolling in a seaway. Modern control theory is a tool which, with judicious use, will assist in generating a satisfactory solution to this optimisation problem.

The question of optimality arises in all engineering design problems. In the realm of modern control theory, optimality is precisely defined by a mathematical formulation known as the performance index. It is very important for the designer to select an appropriate performance index for his problem. If this is done, the control system can be expected to provide the best compromise over all possible variations of the design parameters. However, for some variations in parameters, so-called suboptimal controllers may actually provide better performance. It is important, therefore, to simulate the control system for a number of parameter variations during the design phase.

2. MATHEMATICAL FORMULATION

The mathematical model of ship lateral motions used herein was recently developed at DREA¹. It consists of three linear differential equations for sway, roll and yaw and two linear differential equations which describe the fin and rudder dynamics. Corrections are included for viscous damping due to bilge keels, hull circulatory effects and the effects of hull appendages, i.e., fins, rudders, skeg and propeller shaft brackets. The associated computer program will compute frequency responses and rms motions for any speed and heading to the seaway. This can be done for both stabilised and un-stabilised operation.

If nonzero values of sway, roll, yaw, rudder angle

and fin angle are treated as small perturbations about the reference condition of rectilinear motion in a seaway at constant speed, the lateral equations of motion are:

$$\begin{aligned}
 \text{Sway:} \quad & (A_{22} + m)\ddot{\eta}_2 + B_{22}\dot{\eta}_2 + A_{24}\ddot{\eta}_4 + B_{24}\dot{\eta}_4 + A_{26}\ddot{\eta}_6 \\
 & + (B_{26} + mU)\dot{\eta}_6 + A_{2\delta}\ddot{\delta} + B_{2\delta}\dot{\delta} + C_{2\delta}\delta \\
 & + A_{2\beta}\ddot{\beta} + B_{2\beta}\dot{\beta} + C_{2\beta}\beta = F_2
 \end{aligned} \tag{1}$$

$$\begin{aligned}
 \text{Roll:} \quad & A_{42}\ddot{\eta}_2 + B_{42}\dot{\eta}_2 + (A_{44} + I_4)\ddot{\eta}_4 + B_{44}\dot{\eta}_4 + C_{44}\eta_4 \\
 & + A_{46}\ddot{\eta}_6 + B_{46}\dot{\eta}_6 + A_{4\delta}\ddot{\delta} + B_{4\delta}\dot{\delta} + C_{4\delta}\delta \\
 & + A_{4\beta}\ddot{\beta} + B_{4\beta}\dot{\beta} + C_{4\beta}\beta = F_4
 \end{aligned} \tag{2}$$

$$\begin{aligned}
 \text{Yaw:} \quad & A_{62}\ddot{\eta}_2 + B_{62}\dot{\eta}_2 + A_{64}\ddot{\eta}_4 + B_{64}\dot{\eta}_4 + (A_{66} + I_6)\ddot{\eta}_6 + B_{66}\dot{\eta}_6 \\
 & + A_{6\delta}\ddot{\delta} + B_{6\delta}\dot{\delta} + C_{6\delta}\delta \\
 & + A_{6\beta}\ddot{\beta} + B_{6\beta}\dot{\beta} + C_{6\beta}\beta = F_6
 \end{aligned} \tag{3}$$

$$\text{Rudder:} \quad \ddot{\delta} + 2\zeta_{\delta}\omega_{\delta}\dot{\delta} + \omega_{\delta}^2\delta = \omega_{\delta}^2\delta_c \tag{4}$$

$$\text{Fin:} \quad \ddot{\beta} + 2\zeta_{\beta}\omega_{\beta}\dot{\beta} + \omega_{\beta}^2\beta = \omega_{\beta}^2\beta_c \tag{5}$$

The A_{ij} and B_{ij} are the added mass and damping coefficients, C_{ij} are the stiffness coefficients, and F_j are the exciting forces and moments. These coefficients are frequency dependent and are evaluated for this application at the ship's roll natural frequency. Thus, the controller to be designed will work best at the worst rolling frequencies. Because the coefficients vary rather slowly with frequency, the controller can be expected to be effective over a wide bandwidth. The fin and rudder actuator dynamics, modelled as second order lags, relate the fin or rudder angle commanded by the control system to the actual fin or rudder angle.

The equations of motion in calm seas (i.e., $F_i = 0$) may be expressed in matrix form as

$$\dot{x} = Ax + Bu \quad (6)$$

The system matrix A and input matrix B are constant. The modes of ship motion are given by the eigenvalues of A. The elements of vector x are the system states and the elements of vector u are the control inputs. In the case of active fin control,

$$x = [\dot{\eta}_2 \quad \dot{\eta}_4 \quad \eta_4 \quad \dot{\eta}_6 \quad \dot{\beta} \quad \beta]' \quad (7a)$$

$$u = [\beta_c] \quad (7b)$$

whereas for rudder control

$$x = [\dot{\eta}_2 \quad \dot{\eta}_4 \quad \eta_4 \quad \dot{\eta}_6 \quad \dot{\delta} \quad \delta]' \quad (8a)$$

$$u = [\delta_c] \quad (8b)$$

and for combined fin-rudder control

$$x = [\dot{\eta}_2 \quad \dot{\eta}_4 \quad \eta_4 \quad \dot{\eta}_6 \quad \dot{\delta} \quad \delta \quad \dot{\beta} \quad \beta]' \quad (9a)$$

$$u = [\delta_c \quad \beta_c]' \quad (9b)$$

The prime denotes the vector transpose.

To reduce rolling, the controller will feed back some or all of the states according to

$$u = -Gx \quad (10)$$

The feedback gains are selected so as to command a given level of fin and/or rudder motion in a specified seaway.

3. MODERN CONTROL THEORY

3.1 COMPLETE STATE FEEDBACK

Given the state equation (6), it is up to the designer to derive a control law which achieves the desired levels of closed loop stability and performance. Only linear, time-invariant feedback gains are considered in this Report. The use of modern control theory guarantees that for small perturbations about the reference condition in a calm sea, the closed loop system will be stable. In addition, one may address the performance specifications directly by choosing feedback gains which are optimal in some well-defined sense. The optimal feedback gains will be those which minimise the value of the quadratic performance index

$$J = \frac{1}{2} \int_0^{\infty} (x'Qx + u'Ru)dt \quad (11)$$

Under certain conditions on A, B, Q and R it can be shown⁷ that an optimal control law exists, is unique, and is given by

$$u(t) = -G^*x(t) \quad (12)$$

Matrix G^* is computed using the relation

$$G^* = R^{-1}B'K \quad (13)$$

where the positive definite matrix K is the solution of the nonlinear matrix Riccati equation

$$KA + A'K + Q - KBR^{-1}B'K = 0 \quad (14)$$

Moreover, the closed loop system

$$\dot{x} = A_{CL}x \quad (15a)$$

$$A_{CL} = A - BG^* \quad (15b)$$

is guaranteed to be stable. The closed loop configuration is depicted in Fig. 1.

The aforementioned conditions under which G^* may be identified are now discussed.

- (i) The pair (A, B) must be controllable, meaning that it is possible to influence all system states through the input. Without this condition, it would not be possible to guarantee the stability of A_{CL} , because any instabilities in A may not be affected by feedback.
- (ii) Matrix Q must be positive semidefinite, and matrix R must be positive definite. This is to ensure that $J \geq 0$ always.
- (iii) The pair (A, Q_1) must be observable, where $Q_1'Q_1 = Q$. This requirement ensures that 'the entire state is observable from the cost'; i.e., all the states are available to J if required.

It has been established that these conditions are satisfied for the problem formulation in this Report. Computational methods exist for solving the Riccati equation for K , whereby G^* is obtained using equation (13)⁸.

There are two fundamental differences between classical control system design methods and modern control theory. First, the former is a frequency domain approach while design using modern control theory is carried out in the time domain. The second difference is in philosophy. In classical design, stability is established and then performance specifications are addressed. The use of modern control theory guarantees stability, and performance is specified at the outset by choosing Q and R .

The solution procedure for G^* is automatic once Q and R have been chosen. Selection of appropriate weighting matrices depends solely upon the experience and engineering judgment of the designer. The qualitative dependence of the solution on the relative size of Q and R is as follows:

- (i) The larger the elements of Q become, the larger G^* becomes and the time required to reduce state perturbations to small values decreases. That is, an increase in Q increases the bandwidth of the closed loop system.

- (ii) the larger R becomes, the smaller the gain matrix G^* and the slower the system.

For example, if ship rolling must be reduced regardless of the control activity required, the elements of Q will be chosen much larger than those of R. This means that excursions in the state are heavily penalised over time, so that the optimal feedback gains will have to be quite large to keep x near zero. Conversely, larger elements in R permit more ship motion because control surface activity is reduced. Clearly a compromise is possible between the conflicting requirements of roll attenuation and small control surface deflections.

3.2 OUTPUT FEEDBACK

It can be seen that the optimal feedback configuration requires that all states of the system be available in general. It is likely in many applications, however, that one or more of the states may not even be measurable. In addition the designer may, for reasons of simplicity or reliability, elect to feed back only a subset of the states. Such a situation is now considered.

Assume that y , the output of the system, is a linear combination of the elements of x ; i.e.,

$$y = Cx \quad (16)$$

Only the output y is available for feedback purposes. Therefore the controller to be derived is of the form

$$u = -Fy \quad (17)$$

and the closed loop matrix in this event is

$$A_{CL} = A - BFC \quad (18)$$

Fig. 2 outlines the structure of this system.

As in the case of full state feedback, it is desirable that the solution be optimal in the sense of minimising the performance index J . Unfortunately, the theory does not guarantee the existence or uniqueness of F^* , but it can be shown⁹ that if C^{-1} exists, then F^* and G^* are identical. Assuming that F^* exists, it may be obtained from the relation

$$F^* = R^{-1}B'HLC'(CLC')^{-1} \quad (19)$$

where H is the positive definite solution of the Lyapunov equation

$$H(A - BFC) + (A - BFC)'H + Q + C'F'RFC = 0 \quad (20)$$

and L is the positive definite solution of the Lyapunov equation

$$L(A - BFC)' + (A - BFC)L + I = 0 \quad (21)$$

An algorithm for obtaining F^* is presented in Reference 9. In the case of fin or rudder stabilisation, the algorithm converges nicely to a solution in four or five iterations. When combined fin-rudder control is considered, some convergence problems arise, but they are not insurmountable.

4. ACTIVE FIN STABILISER DESIGN

The hull form selected for use in this Report is that of a frigate whose dimensions are given in Table I. The assumed fins, bilge keels and rudders are described in Table II, and Fig. 3 shows their arrangement on the hull.

For the linear, time-invariant system employed herein, the unstabilised modes of ship motion are given by the eigenvalues of the system matrix A. The dependence of these modes on ship speed is demonstrated in Fig. 4. In the analysis which follows, the ship is assumed to be moving at 18 kt. through a beam sea of 12 ft. significant wave height. At this speed, the open loop roll, sway and yaw eigenvalues are:

roll:	$-0.108 \pm 0.570j$
sway:	-0.126
yaw:	-0.362

The roll mode is lightly damped, so that large roll angles can be expected in the design seaway.

To select the fin control law, recall that fin motions are to be kept below that required for incipient cavitation. Although this critical angle is a strong function of fin geometry, it is assumed that the data of Fig. 5 apply to the fins of Table II. This relation between cavitation angle and ship speed is derived from the roll stabilisation study by Jones and Cox¹⁰. The data indicate that the cavitation limit at 18 kt. is reached when the rms fin angle is 6.5°.

The performance index must be chosen so that the closed loop system generates the most roll reduction for the given level of fin activity. Under the assumption that the control system is to operate continuously, minimisation of equation (11) is equivalent to minimising⁷

$$J = E\{x'Qx + u'Ru\} \quad (22)$$

where E is the statistical expectation. The particular performance index selected for this application includes both roll angle and fin angle, with their relative importance determined by a weighting factor μ :

$$J = E\{\mu\eta_4^2 + \beta_c^2\}, \mu > 0 \quad (23)$$

As μ increases, roll angle becomes more heavily penalised. The modern control theory algorithm responds by selecting large feedback gains so that rms fin motion increases as rms roll angle decreases. The general behaviour is depicted in Fig. 6. The designer chooses the value of μ which, in the design seaway, results in an rms fin angle of 6.5°, the assumed limit. For this example, the optimal control law is found to be

$$\begin{aligned} \beta_c = & -0.015\dot{\eta}_2 - 2.632\dot{\eta}_4 - 1.499\eta_4 - 0.630\dot{\eta}_6 \\ & - 0.007\dot{\beta} - 0.015\beta \end{aligned} \quad (24)$$

The gains shown are expressed in engineering units; i.e., deg/fps, etc. This control law is optimal in the sense that its implementation results in minimisation of the performance index, equation (23). Thus optimality has a strict mathematical definition in this Report, and refers only to

small perturbations about the reference condition of rectilinear motion at constant speed in a calm sea. However, the linearity of the ship/stabiliser system ensures the optimality of the closed loop system in a seaway, as long as the wave forces are assumed to be linear as well.

Optimality of the control law does not automatically imply optimality of the roll stabilisation system, since this depends upon a number of factors not considered in the analysis, such as fin hydrodynamic design and hydraulic system design. Nevertheless, the form of the control law has a major impact on stabiliser performance, other factors being equal. Moreover, if the constraint on fin activity is selected so as to keep the fin from cavitating, then the noise radiated by the stabiliser will be significantly less than that obtainable with the first generation fin stabilisers presently in service. By employing the above methodology to select the control law, the designer can be assured that the control system will provide the best compromise over all possible variations in the design parameters. To predict the overall control system performance in specific sea conditions, for a range of parameter variations, requires that the controller be simulated in a seaway.

Intuition would suggest that the roll angle and roll rate feedback gains should be significantly larger than the other feedback gains in equation (24) and this is indeed the case. The output feedback technique may be used to derive optimal controllers which use only roll rate and roll angle feedbacks. These simpler controllers may then be compared to equation (24) in the design seaway. In this way, the effect of various feedback configurations can be readily assessed and the most practical system chosen. Two configurations are considered:

(i) roll angle and roll rate feedback

(ii) roll rate feedback only.

Using the performance index of equation (23), the optimal control laws corresponding to these configurations are

$$\beta_c = - 2.617\dot{\eta}_4 - 1.508\eta_4 \quad (25)$$

$$\beta_c = - 3.563\dot{\eta}_4 \quad (26)$$

The weighting factor μ is again chosen to give an rms fin motion of 6.5° in the design seaway.

5. ACTIVE RUDDER STABILISER DESIGN

The approach to rudder stabiliser design parallels that for the fin stabiliser except that, because the rudders must also be used to steer the ship, the allowable rudder motions are made more restrictive. The rudders cannot be completely dedicated to roll control, as are fins. An arbitrary limit of 5.0° rms in the design sea is chosen. For the performance index

$$J = E\{\mu\eta_4^2 + \delta_c^2\}, \quad \mu > 0 \quad (27)$$

the corresponding control law in the case of complete state feedback is

$$\begin{aligned} \delta_c = & -0.011\dot{\eta}_2 - 2.880\dot{\eta}_4 - 0.721\eta_4 - 2.395\dot{\eta}_6 \\ & - 0.268\dot{\delta} - 0.408\delta \end{aligned} \quad (28)$$

The δ and $\dot{\delta}$ feedbacks are much larger than the β and $\dot{\beta}$ feedbacks of equation (24) because the assumed rudder dynamics are more sluggish than the fin dynamics. These dynamics, expressed in Table II in terms of damping ratio and natural frequency, are considered to be representative of current ship systems.

Although other feedback configurations are not considered for rudder roll control, they may be obtained if required with the output feedback technique.

6. THE PERFORMANCE OF SINGLE INPUT SYSTEMS

As mentioned above, it is important to verify that the controllers perform adequately in the design seaway. Fig. 7 compares both stabilised and unstabilised rolling motions for the complete fin and rudder controllers, equations (24) and (28). Mean wave periods from 7 to 11 seconds are shown so that the effect of different excitation frequencies can be assessed. The rms fin and rudder motions, averaged over these wave periods, are 6.5° and 5.0° respectively. The active fin system is shown to reduce rolling by 45 percent with respect to the open loop case in a beam sea of 12 ft. significant wave

height with a mean wave period of 9 seconds. The corresponding reduction with active rudder control is 30 percent. Rudder control appears inferior because the actuator dynamics and motion limits assumed for the rudders are more restrictive than for the fins. If these factors were equalised, the performance of the two systems would be very similar.

In addition to rms motions, response amplitude operators are also generated by the DREA ship lateral motions program¹. Plots of these operators are useful because one can readily perceive the effect of variations in the sea spectrum. The operators for the systems evaluated in Fig. 7 are plotted in Fig. 8. The frequency response obtained with the fin system is especially good because the peak response is reduced substantially while the overall response remains at or below unstabilised levels over the entire range. Rudder control is slightly destabilising at the higher frequencies.

Three different control laws for active fin control are assessed in Fig. 9. They correspond to complete state feedback, equation (24), roll angle and roll rate feedback, equation (25), and roll rate feedback, equation (26). This figure, in conjunction with Fig. 7 (open loop), clearly shows that, in beam seas, roll rate is the most important feedback. In fact, roll rate feedback alone is the best controller at the lower wave periods. At the higher wave periods, roll angle feedback is beneficial. This implies that, in a quartering or following sea, roll angle feedback will be important. Since a quartering sea represents the worst heading for ship rolling, it may be worthwhile to implement a special quartering sea mode of controller operation. This new mode would employ roll angle as its primary feedback.

It is not surprising that the roll angle and roll rate feedbacks should dominate, because roll is weakly coupled to the other modes of ship motion. Fig. 9 demonstrates that most of the states can be deleted from the control law in the case of beam seas without seriously degrading system performance.

7. COMBINED FIN-RUDDER CONTROL

In the attempt to reduce roll using coordinated fin and rudder deflections it is not sufficient to install two independently-designed fin and rudder systems. The complete controller must be derived as a unit in order to achieve a truly optimal solution. The performance index to be considered is

$$J = E\{\mu_1 \eta_4^2 + \mu_2 \delta_c^2 + \beta_c^2\} \quad (29)$$

where the weighting factors μ_1 and μ_2 are selected to achieve 5.0° rms rudder motion and 6.5° rms fin motion in the design sea.

The investigation of combined fin-rudder control is motivated by the hope that such a system would perform significantly better than active fins acting alone. That is, systems considered in this section should, for the given levels of fin and rudder motion, result in significantly less roll than those controllers shown in Fig. 9. In addition, the desired controller should feed back only a subset of the states. Implementation of complete state feedback would necessitate a total of sixteen feedbacks, eight to each actuator. Such a configuration is obviously impractical. With the optimal output feedback technique, it is possible to derive control laws for the combined fin-rudder controller which require only a few states.

The roll angle and roll rate feedbacks are the most influential, and so only these two are considered. Unfortunately, the optimal output feedback algorithm fails to converge for this case. Yaw rate is included in the control law to make the algorithm converge. The given levels of fin and rudder motion in the design seaway are obtained with $\mu_1 = 23.3$ and $\mu_2 = 18.2$. The corresponding control law is

$$\delta_c = -2.424 \dot{\eta}_4 - 1.918 \eta_4 + 3.385 \dot{\eta}_6 \quad (30a)$$

$$\beta_c = -2.476 \dot{\eta}_4 - 1.613 \eta_4 - 0.320 \dot{\eta}_6 \quad (30b)$$

It can be shown that the performance is practically unaffected by deleting the yaw rate feedbacks. Therefore the use of roll rate and roll angle together yields the following controller:

$$\delta_c = -2.424 \dot{\eta}_4 - 1.918 \eta_4 \quad (31a)$$

$$\beta_c = -2.476 \dot{\eta}_4 - 1.613 \eta_4 \quad (31b)$$

The other controller to be considered in this section uses only roll rate feedback. Its form is

$$\delta_c = - 5.50\dot{\eta}_4 \quad (32a)$$

$$\beta_c = - 4.20\dot{\eta}_4 \quad (32b)$$

The rolling obtained with the controllers defined by equations (31) and (32) is compared in Fig. 10 with the performance of the active fin controller, equation (26), which employs only roll rate feedback. The use of roll angle and roll rate in the combined fin-rudder control law yields only a slight improvement over the fin controller. However, the use of roll rate feedback alone in the combined fin-rudder controller results in a marked performance improvement. The improvement is very significant, and may justify the consideration of a combined fin-rudder controller for roll stabilisation, since the combined system is superior to any of the active fin controllers discussed above.

As a last exercise, the influence of the rudder actuator dynamics is examined. As shown in Table II, the rudder actuator bandwidth is only 20% of the fin actuator bandwidth. For the case of roll rate feedback only, Fig. 11 illustrates the effect of a rudder servo which is improved to the standards of the fin servo. The control law used for Fig. 11 is identical for both systems and is, in fact, equation (32). As might be expected, the effect of upgraded rudder dynamics is most apparent for the lower mean wave periods, corresponding to higher encounter frequencies. When these higher wave frequencies are encountered, the original rudder dynamics are unable to respond quickly enough, and large lags between commanded and actual rudder position result. This effect degrades the capability of the stabiliser. Conversely, the roll reduction obtained with the upgraded dynamics is effectively independent of encounter frequency for the frequencies considered here.

Improving the rudder dynamics has a beneficial effect on fin motions. The upgraded dynamics require a 4.8° rms fin motion to achieve the performance demonstrated in Fig. 11, compared to 6.5° for the original rudder dynamics. Rudder rms motions are approximately 5.0° in both instances. This phenomenon is physically reasonable because large lags in rudder position can amplify roll motions and require more fin motion to achieve a given level of stabilisation. With improved rudder

der dynamics, the fins are not required to counter lags in the rudder actuator.

One last point to be made is that none of the controllers discussed in this Report degrade the sway and yaw modes of ship motion to a significant degree. The rms sway and yaw motions do not exceed 2.7 fps or 0.23° respectively for any of the controllers. The corresponding open loop values are 1.8 fps and 0.19° . Because sway and yaw are low frequency modes compared to roll, they are not excited by control surface motion at common rolling frequencies.

8. CONCLUDING REMARKS

The application of modern control theory to the design of active controllers for ship roll stabilisation has been demonstrated. In the examples, systems employing fins, rudders and a combination of fins and rudders have been examined. In addition, consideration has been given to the implementation of various feedback configurations. On the basis of this work, a number of remarks follow.

- (1) Modern control theory is a powerful tool in the design of active roll stabilisers. The derived control laws attenuate roll effectively in the design seaway, without the onset of control surface cavitation.
- (2) In order to obtain realistic results using this design procedure, it is important to experimentally verify the deflection angle for which a given lifting surface will cavitate. This angle is a strong function of geometry.
- (3) Only the reduced noise mode of operation is considered here. The normal mode of operation, in which the control surfaces are allowed to cavitate, will reduce roll to a greater extent than the reduced noise mode, although radiated noise will increase. These modes of operation can be accommodated with ease in the controller software.
- (4) The most important feedback for the seaways considered here is roll rate. However, for very low frequencies (as in a quartering sea), Fig. 9 indicates that roll angle would be the most important feedback. Therefore a quarter-

ing sea mode could be beneficial in addition to the normal and reduced noise modes of operation. Control laws for each mode could be stored in an on-board computer and activated by a switch on the bridge.

- (5) This analysis has been restricted to a constant ship speed of 18 kt. Equally good performance can be expected for other speeds if the optimal gains are computed as a function of speed and stored in the computer, to be recalled when needed.
- (6) Neither rudder nor fin control degrades the sway or yaw modes of ship motion.
- (7) The ship's rudders have the potential to reduce roll effectively, but it has not yet been shown that conventional rudder servomechanisms can cope reliably with this additional activity throughout the service life of the ship.
- (8) Improvement of the rudder dynamics provides a significant benefit in terms of roll-reducing capability. If the rudder dynamics were upgraded to the level of the fin dynamics, the rudder controller, equation (28), would perform as well as the fin controller, equation (24).
- (9) Modern control theory becomes more appropriate as the number of inputs and states increases. In a futuristic vein, the theory is well-suited to the overall initial design of a stabiliser-plus-autopilot system. The ship's fins, rudders and controllable-pitch propellers could all be coordinated to control heading, speed and roll angle.

TABLE I: HULL PARTICULARS

length between perpendiculars	393.7 ft
beam	47.6 ft
draft	14.5 ft
displacement	3711 tons
metacentric height	4.2 ft
longitudinal c.g. location	202.6 ft
height of c.g. above waterplane	7.0 ft

TABLE II: SELECTED APPENDAGES

A.	Fins - one pair, trapezoidal unflapped	
	span	7.5 ft
	root chord	11.8 ft
	taper ratio	0.7
	depression	42 deg
	actuator damping ratio	0.4
	actuator natural frequency	5.0 rps
B.	Bilge Keels - one pair, forward of fins	
	span	2.5 ft
	length	78.8 ft
C.	Rudders - one pair, trapezoidal spade	
	span	12.4 ft
	root chord	9.2 ft
	taper ratio	0.5
	actuator damping ratio	0.8
	actuator natural frequency	1.0 rps

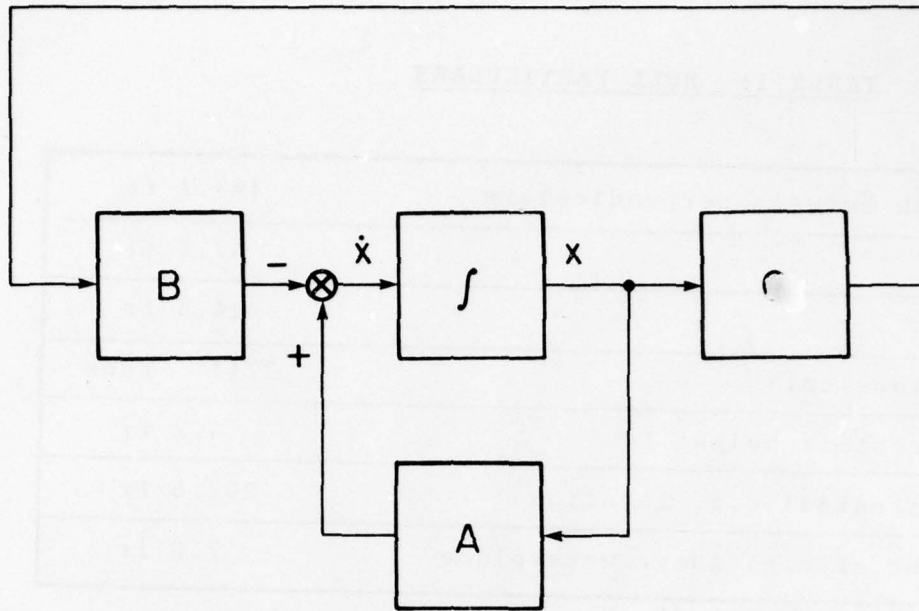

Figure 1: Closed Loop Configuration, Full State Feedback.

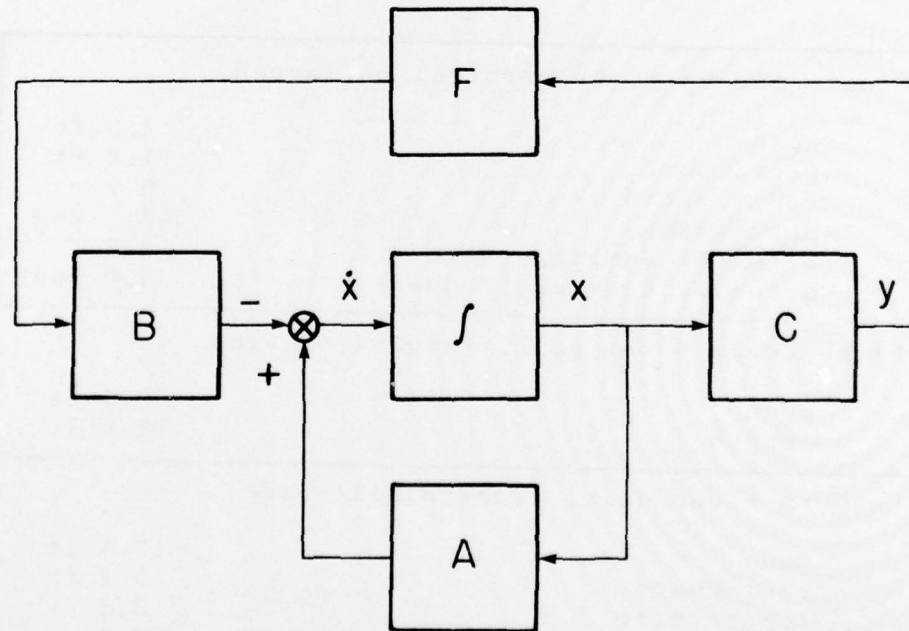

Figure 2: Closed Loop Configuration, Output Feedback.

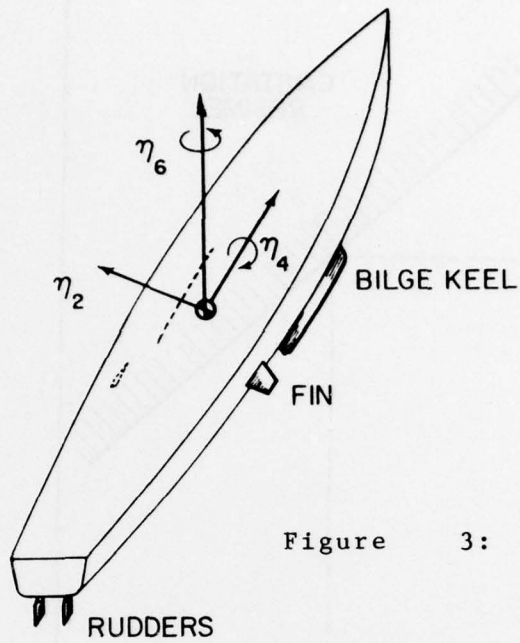

Figure 3: Appendage Arrangement.

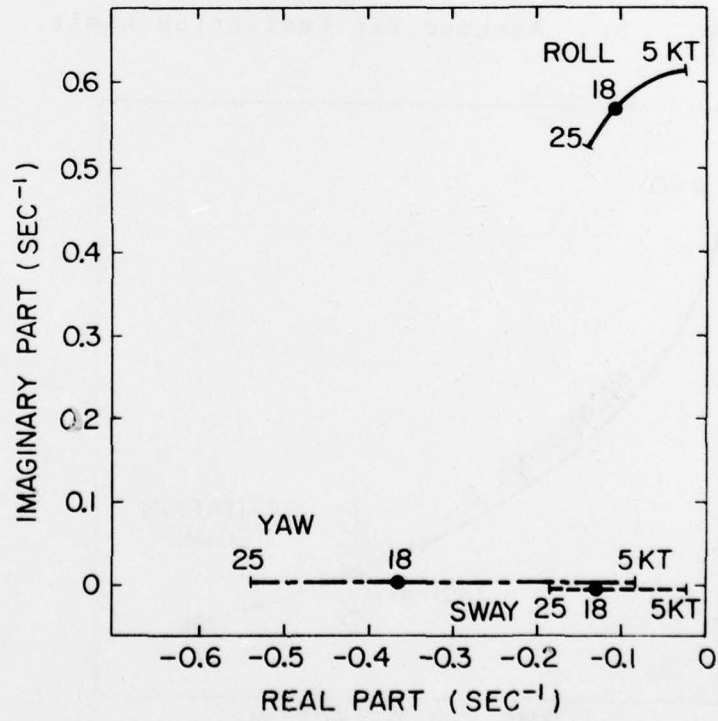

Figure 4: Open Loop Eigenvalues vs. Speed, 5 - 25 kt.

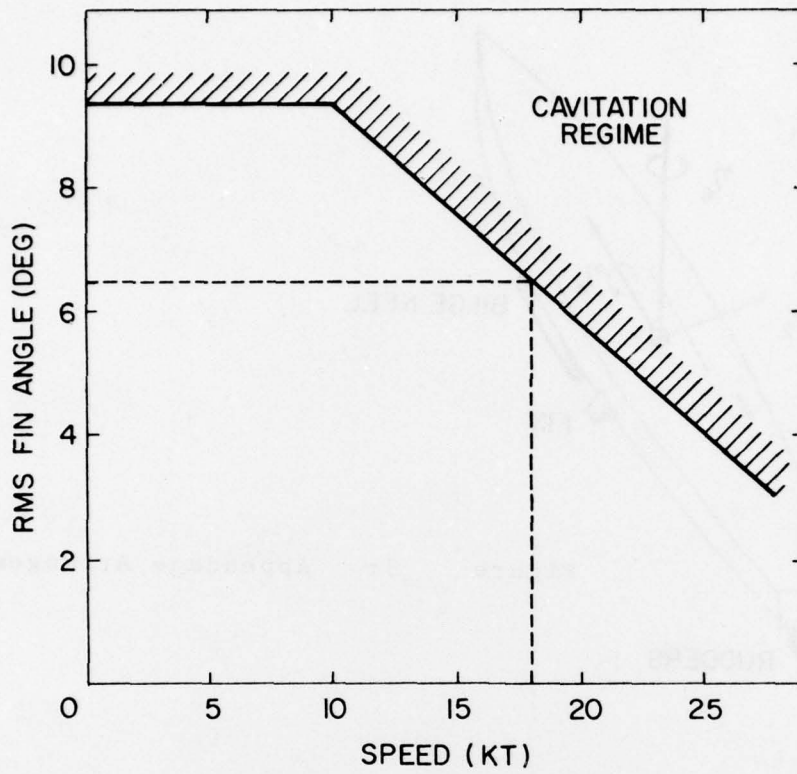

Figure 5: Assumed Fin Cavitation Limit.

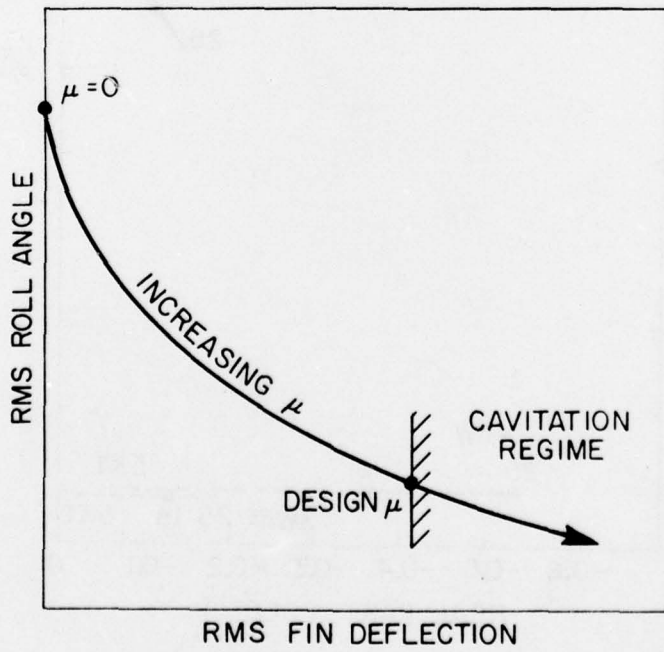

Figure 6: Selection of Weighting Factor μ .

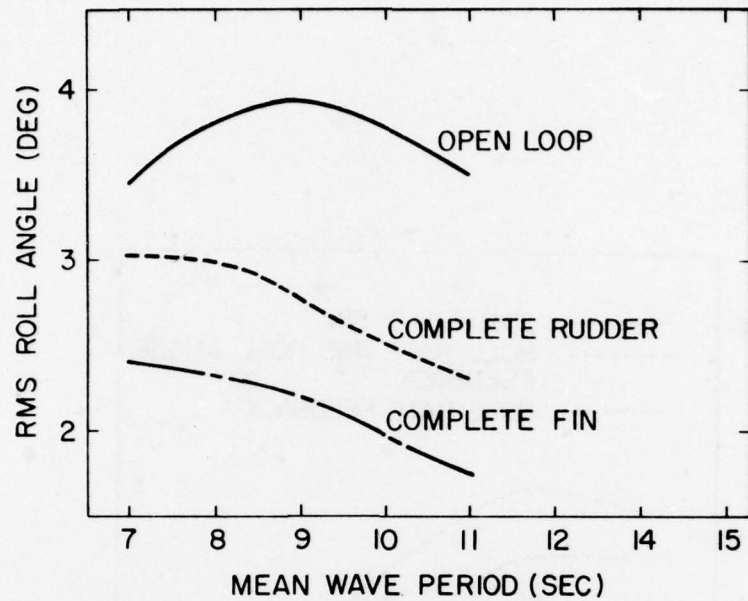

Figure 7: RMS Roll Angles for Complete State Feedback as Compared to Open Loop Case.

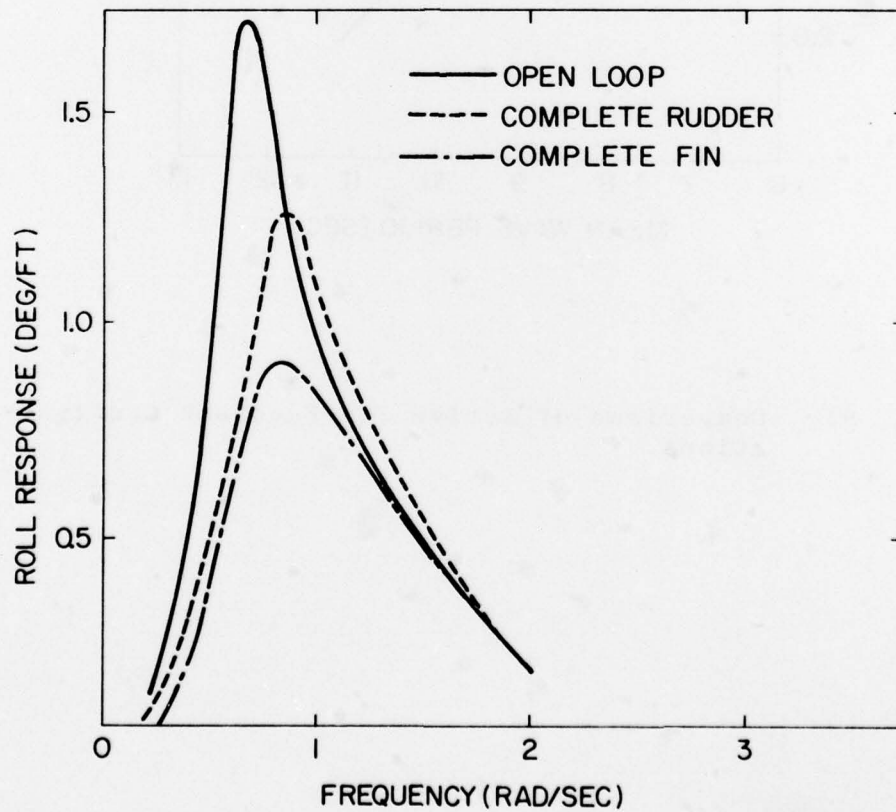

Figure 8: Response Amplitude Operators for Complete State Feedback as Compared to Open Loop Case.

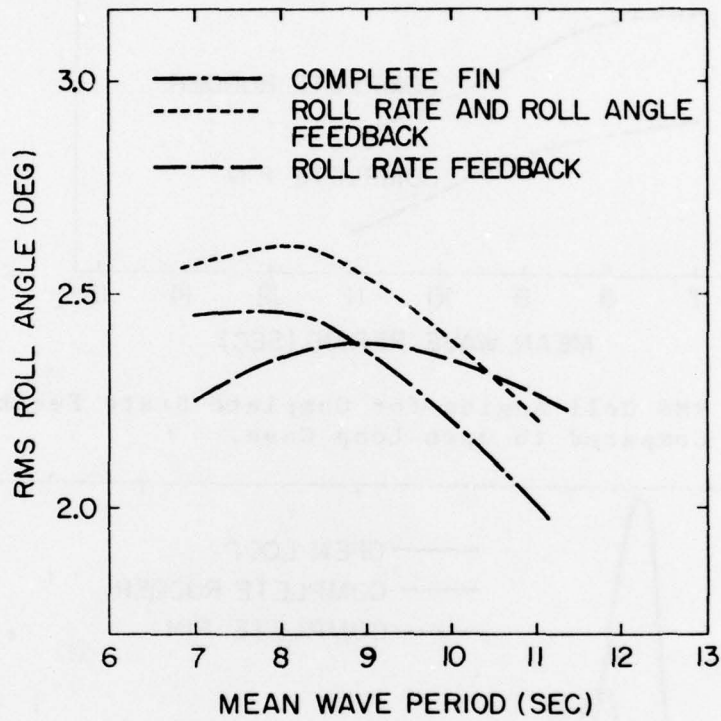

Figure 9: Comparison of Active Fin Feedback Configurations.

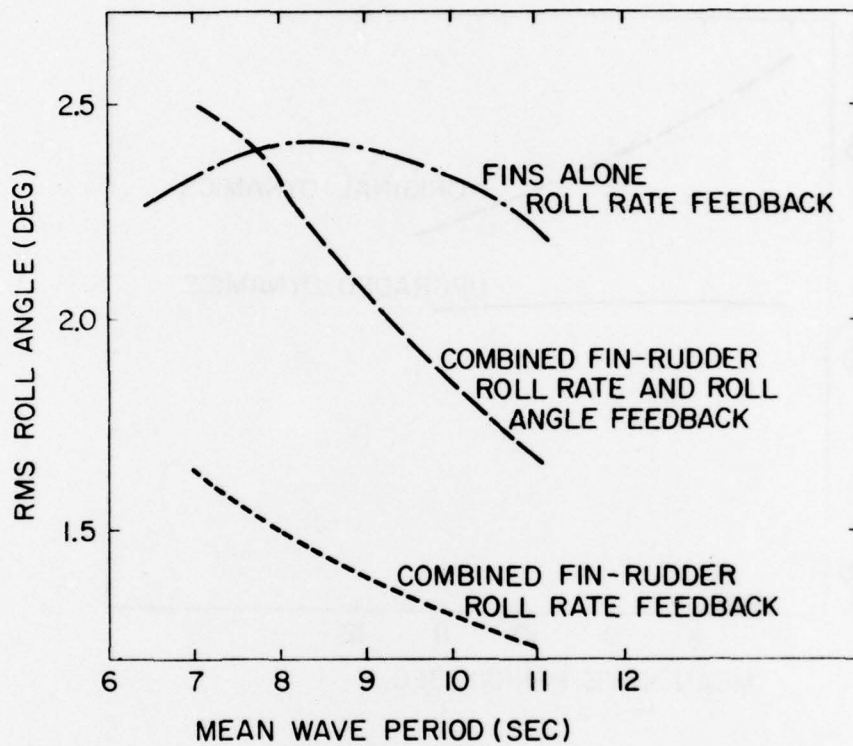

Figure 10: Comparison of RMS Roll Angles Obtained with Combined Fin-Rudder Control to RMS Roll Angles Obtained with Fins Acting Alone.

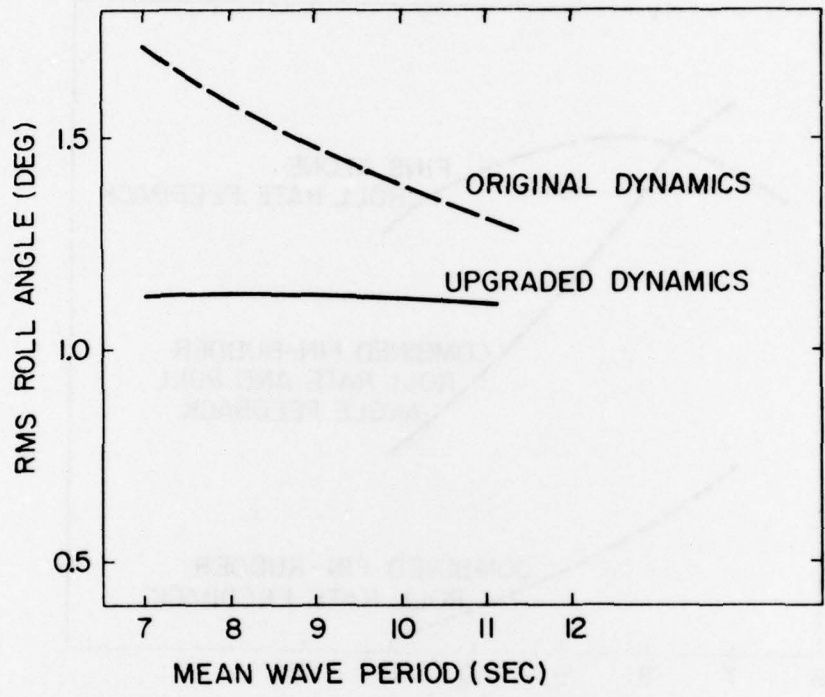

Figure 11: Effect of Rudder Dynamics on Performance of the Combined Fin-Rudder Controller with Roll Rate Feedback.

REFERENCES

1. Schmitke, R. T.: "Prediction of Ship Roll, Sway and Yaw Motions in Oblique Waves", DREA Report 77/4, September 1977.
2. Cowley, W. E., Lambert, T. H.: "Sea Trials on a Roll Stabiliser Using the Ship's Rudder", Fourth Ship Control Systems Symposium, October 1975.
3. Hsu, S. K.: "Application for Optimal Control Theory to a Large Hydrofoil Craft", Fourth Ship Control Systems Symposium, October 1975.
4. Whyte, P. H.: "Optimal Control of Hydrofoil Ship Lateral Dynamics", Fifth Ship Control Systems Symposium, October 1978.
5. Lima, C. et al: "Automatic Control for Replenishment at Sea", Proceedings of the IV Ship Control Systems Symposium, October 1975.
6. Parsons, M. G. and Cuong, H. T.: "Optimal Stochastic Path Control of Surface Ships in Shallow Water", ONR Report CR215-249-2F, August 1977.
7. Athans, M.: "The Role and Use of the Stochastic Linear-Quadratic-Gaussian Problem in Control System Design", IEEE Transactions on Automatic Control, Vol. AC-16, December 1971.
8. Sandell, N. R., Athans, M.: "Manual of FORTRAN Computer Subroutines for Linear, Quadratic, Gaussian Designs", MIT Press, 1974.
9. Levine, W. S. and Athans, M.: "On the Determination of the Optimal Constant Output Feedback Gains for Linear Multivariable Systems", IEEE Transactions on Automatic Control, Vol. AC-15, No. 1, February 1970.
10. Jones, H. D., Cox, G. G.: "Roll Stabilisation Investigation for the Guided Missile Frigate (FFG-7)", NSRDC Report SPD-495-18, July 1976.

UNCLASSIFIED

Security Classification

DOCUMENT CONTROL DATA - R & D		
<small>(Security classification of title, body of abstract and indexing annotation must be entered when the overall document is classified)</small>		
1. ORIGINATING ACTIVITY Defence Research Establishment Atlantic	2a. DOCUMENT SECURITY CLASSIFICATION UNCLASSIFIED	
2b. GROUP		
3. DOCUMENT TITLE ON THE APPLICATION OF MODERN CONTROL THEORY TO SHIP ROLL STABILISATION		
4. DESCRIPTIVE NOTES (Type of report and inclusive dates) DREA Report		
5. AUTHOR(S) (Last name, first name, middle initial) WHYTE, P.H.		
6. DOCUMENT DATE January 1978	7a. TOTAL NO. OF PAGES 33	7b. NO. OF REFS 10
8a. PROJECT OR GRANT NO. 23B	9a. ORIGINATOR'S DOCUMENT NUMBER(S) DREA REPORT 79/2	
8b. CONTRACT NO.	9b. OTHER DOCUMENT NO.(S) (Any other numbers that may be assigned this document)	
10. DISTRIBUTION STATEMENT		
11. SUPPLEMENTARY NOTES	12. SPONSORING ACTIVITY DREA	
13. ABSTRACT <p>The high feedback gains employed by current active roll stabilisation systems result in control surface cavitation and excessive machinery activity, both of which contribute significantly to the noise radiated by the ship. In the case of warships, this noise is most undesirable. To circumvent this difficulty, a reduced noise mode of operation is proposed for use in a threat situation. This reduced noise mode is characterised by little or no cavitation and low levels of machinery wear.</p> <p>A design procedure incorporating modern control theory as the major tool in the selection of feedback gains for ship roll stabilisation is presented. The procedure is applied to the reduced noise mode, but may be readily adapted to controller design for other modes of operation. With this technique, the designer is able to minimise a performance index which is a function of both roll angle and fin angle, while keeping fin motions below the cavitation limit. Application to an example ship configuration employing fin, rudder or combined fin-rudder control is considered. The closed loop performance of these systems is simulated and the results demonstrate the power of modern control theory in this application.</p>		

DDIS
76-970

KEY WORDS

Stabilisation
Fins
Rudders
Roll

INSTRUCTIONS

1. **ORIGINATING ACTIVITY:** Enter the name and address of the organization issuing the document.
2. **DOCUMENT SECURITY CLASSIFICATION:** Enter the overall security classification of the document including special warning terms whenever applicable.
- 2b. **GROUP:** Enter security reclassification group number. The three groups are defined in Appendix 'M' of the DRB Security Regulations.
3. **DOCUMENT TITLE:** Enter the complete document title in all capital letters. Titles in all cases should be unclassified. If a sufficiently descriptive title cannot be selected without classification, show title classification with the usual one-capital-letter abbreviation in parentheses immediately following the title.
4. **DESCRIPTIVE NOTES:** Enter the category of document, e.g. technical report, technical note or technical letter. If appropriate, enter the type of document, e.g. interim, progress, summary, annual or final. Give the inclusive dates when a specific reporting period is covered.
5. **AUTHOR(S):** Enter the name(s) of author(s) as shown on or in the document. Enter last name, first name, middle initial. If military, show rank. The name of the principal author is an absolute minimum requirement.
6. **DOCUMENT DATE:** Enter the date (month, year) of Establishment approval for publication of the document.
- 7a. **TOTAL NUMBER OF PAGES:** The total page count should follow normal pagination procedures, i.e., enter the number of pages containing information.
- 7b. **NUMBER OF REFERENCES:** Enter the total number of references cited in the document.
- 8a. **PROJECT OR GRANT NUMBER:** If appropriate, enter the applicable research and development project or grant number under which the document was written.
- 8b. **CONTRACT NUMBER:** If appropriate, enter the applicable number under which the document was written.
- 9a. **ORIGINATOR'S DOCUMENT NUMBER(S):** Enter the official document number by which the document will be identified and controlled by the originating activity. This number must be unique to this document.
- 9b. **OTHER DOCUMENT NUMBER(S):** If the document has been assigned any other document numbers (either by the originator or by the sponsor), also enter this number(s).
10. **DISTRIBUTION STATEMENT:** Enter any limitations on further dissemination of the document, other than those imposed by security classification, using standard statements such as:
- (1) "Qualified requesters may obtain copies of this document from their defence documentation center."
 - (2) "Announcement and dissemination of this document is not authorized without prior approval from originating activity."
11. **SUPPLEMENTARY NOTES:** Use for additional explanatory notes.
12. **SPONSORING ACTIVITY:** Enter the name of the departmental project office or laboratory sponsoring the research and development. Include address.
13. **ABSTRACT:** Enter an abstract giving a brief and factual summary of the document, even though it may also appear elsewhere in the body of the document itself. It is highly desirable that the abstract of classified documents be unclassified. Each paragraph of the abstract shall end with an indication of the security classification of the information in the paragraph (unless the document itself is unclassified) represented as (TS), (S), (C), (R), or (U).

The length of the abstract should be limited to 20 single-spaced standard typewritten lines; 7 1/4 inches long.
14. **KEY WORDS:** Key words are technically meaningful terms or short phrases that characterize a document and could be helpful in cataloging the document. Key words should be selected so that no security classification is required. Identifiers, such as equipment model designation, trade name, military project code name, geographic location, may be used as key words but will be followed by an indication of technical context.