

AD-A072 950

KIMBALL (L ROBERT) AND ASSOCIATES EBENSBURG PA  
NATIONAL DAM INSPECTION PROGRAM. STEPHEN FOSTER DAM (NDS ID NUM--ETC(U)  
JUN 79

F/G 13/2  
DACW31-79-C-0009  
NL

UNCLASSIFIED

| OF |

AD  
A072950

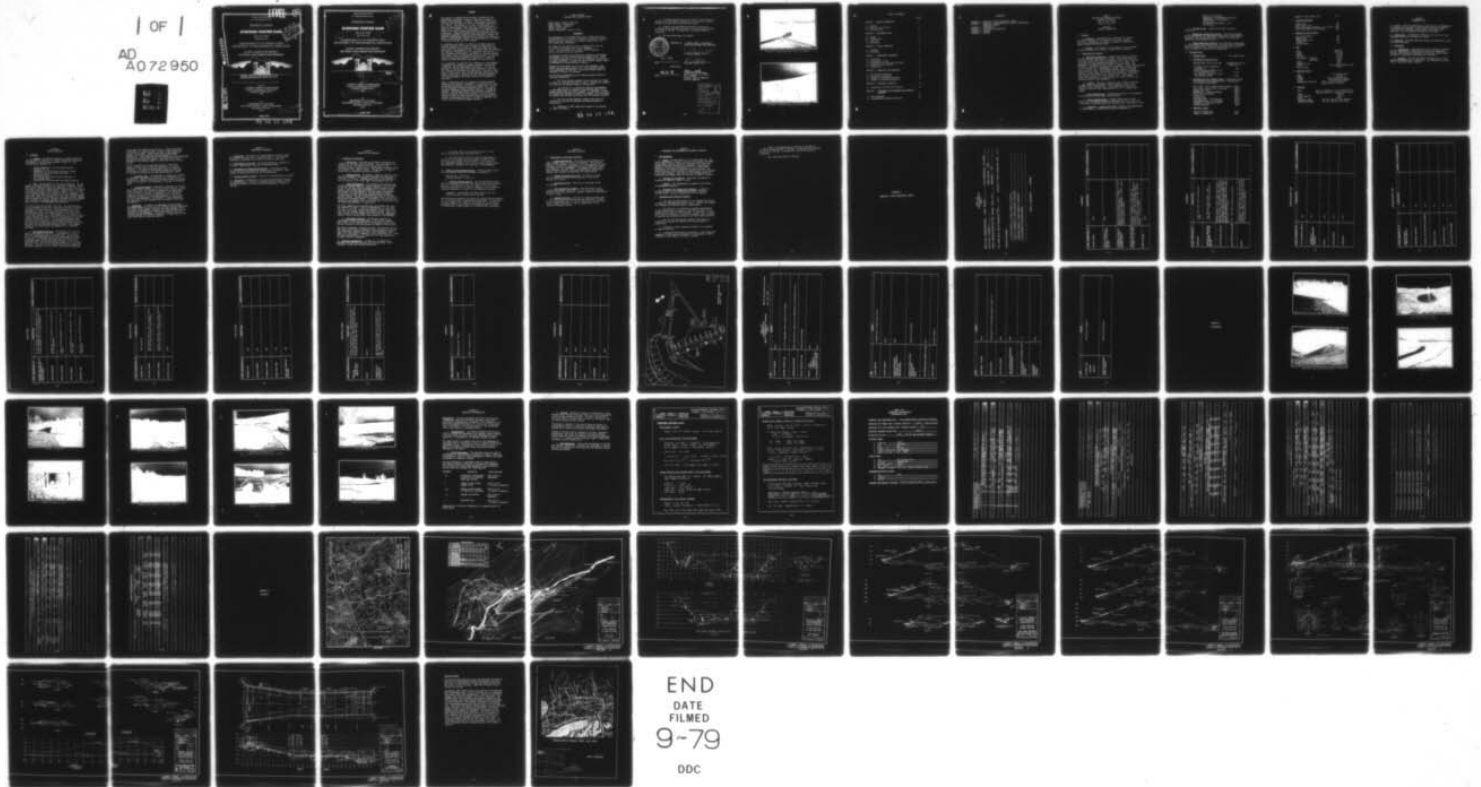

END  
DATE  
FILMED  
9-79  
DDC

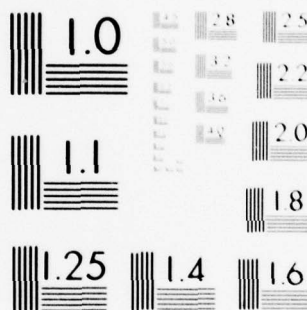

MICROCOPY RESOLUTION TEST CHART  
NATIONAL BUREAU OF STANDARDS-1963-A

**LEVEL**

④

SUSQUEHANNA RIVER BASIN  
MILL CREEK, BRADFORD COUNTY

PENNSYLVANIA

**STEPHEN FOSTER DAM**

NDS ID NO. PA-906  
DER ID NO. 8-59

DDC  
AUG 17 1979  
RECEIVED

PA 072950

COMMONWEALTH OF PENNSYLVANIA  
DEPARTMENT OF ENVIRONMENTAL RESOURCES

PHASE I INSPECTION REPORT  
NATIONAL DAM INSPECTION PROGRAM

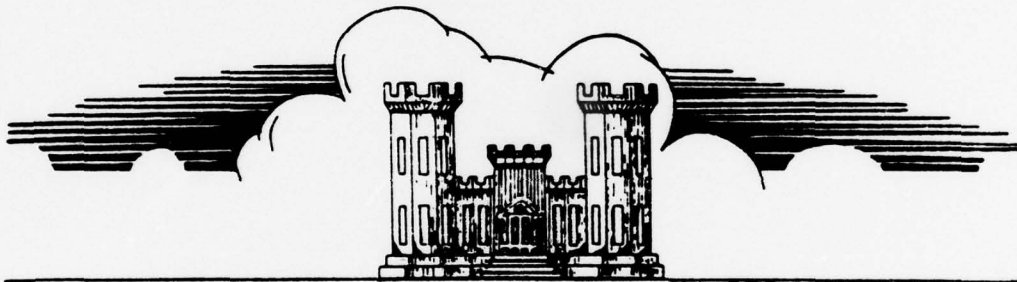

ORIGINAL CONTAINS COLOR PLATES: ALL DDC  
REPRODUCTIONS WILL BE IN BLACK AND WHITE.

Contract # PA CW 31-79-C-0009

Prepared By

**L. ROBERT KIMBALL & ASSOCIATES**  
CONSULTING ENGINEERS & ARCHITECTS  
EBENSBURG, PENNSYLVANIA  
15931

DDC FILE COPY

FOR  
DEPARTMENT OF THE ARMY  
BALTIMORE DISTRICT CORPS OF ENGINEERS  
BALTIMORE, MARYLAND  
21203

This document has been approved  
for public release and sale in  
distribution is unlimited.

JUNE, 1979

79 08 15 088

SUSQUEHANNA RIVER BASIN  
MILL CREEK, BRADFORD COUNTY

PENNSYLVANIA

# STEPHEN FOSTER DAM

NDS ID NO. PA-906

DER ID NO. 8-59

12 77p

11 Jun 79

B D D C  
RECEIVED  
AUG 17 1979  
C

COMMONWEALTH OF PENNSYLVANIA  
DEPARTMENT OF ENVIRONMENTAL RESOURCES

## PHASE I INSPECTION REPORT NATIONAL DAM INSPECTION PROGRAM

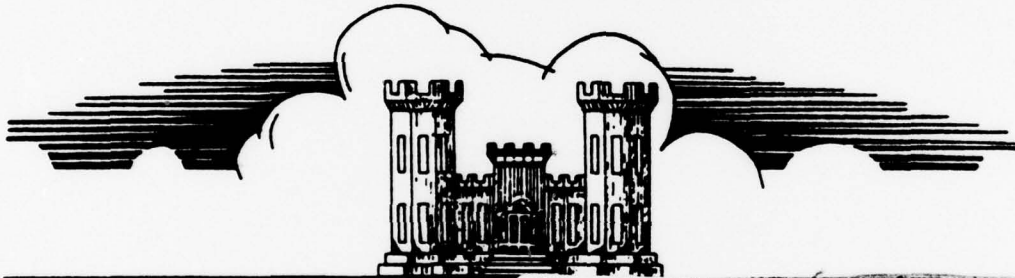

6 National Dam Inspection Program.  
Stephen Foster Dam (NDS ID Number  
PA-906 DER ID Number 8-59),  
Susquehanna River Basin, Mill Creek,  
Bradford County, Pennsylvania. Phase I  
Prepare Inspection Report.

**L. ROBERT KIMBALL & ASSOCIATES**  
CONSULTING ENGINEERS & ARCHITECTS  
EBENSBURG, PENNSYLVANIA  
15931

15 DACW31-79-C-4449

FOR  
DEPARTMENT OF THE ARMY  
BALTIMORE DISTRICT CORPS OF ENGINEERS  
BALTIMORE, MARYLAND  
21203

This document has been approved  
for release and sale; its  
distribution is unlimited.

411059/40 JUNE, 1979

79 08 15 088

## PREFACE

This report is prepared under guidance contained in the Recommended Guidelines for Safety Inspection of Dams, for Phase I Investigations. Copies of these guidelines may be obtained from the Office of Chief of Engineers, Washington, D.C. 20314. The purpose of a Phase I investigation is to identify expeditiously those dams which may pose hazards to human life or property. The assessment of the general condition of the dam is based upon available data and visual inspections. Detailed investigation, and analyses involving topographic mapping, subsurface investigations, testing, and detailed computational evaluations are beyond the scope of a Phase I investigation; however, the investigation is intended to identify any need for such studies.

In reviewing this report, it should be realized that the reported condition of the dam is based on observations of field conditions at the time of inspection along with data available to the inspection team. In cases where the reservoir was lowered or drained prior to inspection, such action, while improving the stability and safety of the dam, removes the normal load on the structure and may obscure certain conditions which might otherwise be detectable if inspected under the normal operating environment of the structure.

It is important to note that the condition of a dam depends on numerous and constantly changing internal and external conditions, and is evolutionary in nature. It would be incorrect to assume that the present condition of the dam will continue to represent the condition of the dam at some point in the future. Only through frequent inspections can unsafe conditions be detected and only through continued care and maintenance can these conditions be prevented or corrected.

Phase I inspections are not intended to provide detailed hydrologic and hydraulic analyses. In accordance with the established Guidelines, the spillway design flood is based on the estimated "Probable Maximum Flood" for the region (greatest reasonably possible storm runoff), or fractions thereof. The spillway design flood provides a measure of relative spillway capacity and serves as an aid in determining the need for more detailed hydrologic and hydraulic studies, considering the size of the dam, its general condition and the downstream damage potential.

PHASE I REPORT  
NATIONAL DAM INSPECTION REPORT

NAME OF DAM: Stephen Foster Dam  
STATE LOCATED: Pennsylvania  
COUNTY LOCATED: Bradford  
STREAM: Mill Creek  
DATE OF INSPECTION: April 16, 1979

ASSESSMENT

The assessment of the Stephen Foster Dam is based upon visual observations made at the time of inspection, review of available records and data, hydrology and hydraulic computations, and past operational performance.

The inspection and review of data of Stephen Foster Dam did not reveal any problems which require emergency action. The dam appears to be stable, well maintained, safely operated and in good condition.

The existing spillway and reservoir are capable of controlling approximately 71% of the PMF (Probable Maximum Flood). Based on criteria established by the Corps of Engineers, the spillway is termed inadequate. Raising the right spillway wingwall should be performed to increase spillway capacity.

Seepage was noted above the toe on the right abutment. The effect that the seepage zones have on the long-term stability of the embankment is uncertain. Additional studies should be conducted to evaluate the seepage.

The following recommendations and remedial measures should be instituted immediately.

1. The right spillway wingwall of the spillway weir should be raised to a minimum elevation of 1092.5. Raising this wingwall will increase the spillway capacity substantially.
2. The services of a professional engineer knowledgeable in dam design should be retained to evaluate the effect of the seepage exiting from the right abutment. In addition, a v-notch weir should be installed to collect the seepage. The flow should be measured and recorded periodically and the turbidity observed.
3. The left spillway approach channel slope should be stabilized to prevent the approach from being blocked by a future slide.
4. Institute a formal inspection program to be conducted at regular intervals.

5. A warning system should be instituted to warn downstream residences of high spillway discharges, during periods of heavy rainfall or heavy runoff or failure of the dam.

6. Access to the dam should be improved so the dam is accessible during periods of flooding. Access should be provided to the top of the dam. A bridge over the spillway should be considered.

7. The trash boom should be repaired.



SUBMITTED BY: L. ROBERT KIMBALL & ASSOCIATES  
CONSULTING ENGINEERS AND ARCHITECTS

*R. Jeffrey Kimball*  
R. Jeffrey Kimball, P.E.

JUN 12 1979

Date

*K. Chuang*  
Kuang-Hwei Chuang, P.E.

APPROVED BY:

28 Jun 79

Date

*F. K. Withers*  
F. K. WITHERS  
Colonel, Corps of Engineers  
District Engineer

Accession For	
NTIS GRA&I	<input checked="" type="checkbox"/>
DDC TAB	<input type="checkbox"/>
Unannounced	<input type="checkbox"/>
Justification	<i>Per [signature]</i>
By <i>[signature]</i>	
Distribution/	
Availability Codes	
Dist	Avail and/or special
<i>A</i>	

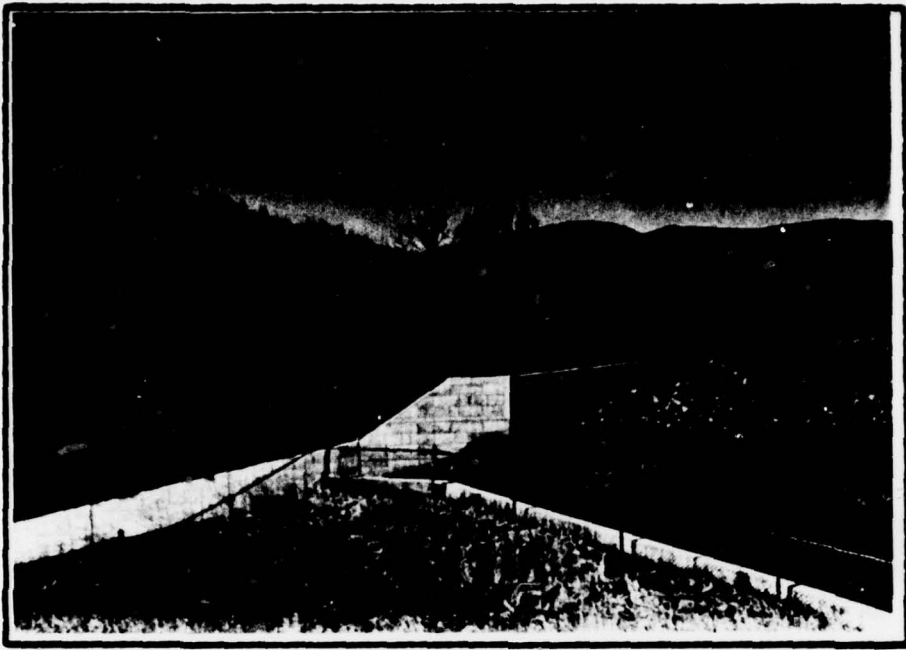

Overview of downstream slope from left abutment.



Overview of upstream slope from left abutment.

## TABLE OF CONTENTS

	PAGE
SECTION 1 - PROJECT INFORMATION	1
1.1 General	1
1.2 Description of Project	1
1.3 Pertinent Data	2
SECTION 2 - ENGINEERING DATA	4
2.1 Design	4
2.2 Construction	4
2.3 Operation	4
2.4 Evaluation	4
SECTION 3 - VISUAL INSPECTION	5
3.1 Findings	5
3.2 Evaluation	6
SECTION 4 - OPERATIONAL PROCEDURES	7
4.1 Procedures	7
4.2 Maintenance of Dam	7
4.3 Maintenance of Operating Facilities	7
4.4 Warning System in Effect	7
4.5 Evaluation	7
SECTION 5 - HYDRAULICS AND HYDROLOGY	8
5.1 Evaluation of Features	8
5.2 Evaluation Assumptions	8
5.3 Summary of Overtopping Analysis	9
5.4 Summary of Dam Breach Analysis	9
SECTION 6 - STRUCTURAL STABILITY	10
6.1 Evaluation of Structural Stability	10
SECTION 7 - ASSESSMENT AND RECOMMENDATIONS/REMEDIAL MEASURES	11
7.1 Dam Assessment	11
7.2 Recommendations/Remedial Measures	11

## APPENDICES

- APPENDIX A - CHECKLIST, VISUAL INSPECTION, PHASE I
- APPENDIX B - CHECKLIST, ENGINEERING DATA, DESIGN, CONSTRUCTION  
OPERATION, PHASE I
- APPENDIX C - PHOTOGRAPHS
- APPENDIX D - HYDROLOGY AND HYDRAULICS
- APPENDIX E - DRAWINGS
- APPENDIX F - GEOLOGY

PHASE I  
NATIONAL DAM INSPECTION PROGRAM  
STEPHEN FOSTER DAM  
NDI I.D. NO. PA 906  
DER I.D. NO. 8-59

SECTION 1  
PROJECT INFORMATION

1.1 General.

a. Authority. The National Dam Inspection Act, Public Law 92-367, authorized the Secretary of the Army, through the Corps of Engineers, to initiate a program of inspection of dams throughout the United States.

b. Purpose. The purpose of the inspection is to determine if the dam constitutes a hazard to human life or property.

1.2 Description of Project.

a. Dam and Appurtenances. Stephen Foster Dam is an earth-fill dam 500 feet long and 49 feet high. The upstream slope is 3H:1V and covered with riprap to elevation 1085. The core trench is 10 feet wide and averages approximately 5 feet deep. The embankment is homogeneous and contains no distinct zones. The spillway is located on the left (north) abutment. The spillway approach is cut in earth and is trapezoidal in shape. The concrete ogee weir is 80 feet long. The spillway approach channel is approximately 600 feet long. The spillway exit channel is approximately 230 feet long and consists of a concrete lined chute. The draw-down conduit consists of a 48" concrete pipe. The drawdown conduit is regulated by a valve located in a control tower in the upstream portion of the embankment.

b. Location. The dam is located on Mill Creek, a tributary to Sugar Creek, approximately 5 miles northeast of East Troy, Bradford County, Pennsylvania. The Stephen Foster Dam can be located on the East Troy, Pennsylvania U.S.G.S. 7.5 minute quadrangle.

c. Size Classification. Stephen Foster Dam is an intermediate size structure (49 feet high, 2043 acre-feet).

d. Hazard Classification. Stephen Foster Dam is a high hazard dam. Downstream conditions indicate that loss of more than a few lives is probable should the structure fail. (See section 3.1e).

e. Ownership. Stephen Foster Dam is owned by the Commonwealth of Pennsylvania. Correspondence should be addressed to:

Bureau of State Parks  
 Department of Environmental Resources  
 Commonwealth of Pennsylvania  
 3rd and Riley  
 Harrisburg, Pennsylvania 17120  
 717-787-6644

f. Purpose of Dam. Stephen Foster Dam is used for recreation.

g. Design and Construction History. The dam was designed by the Commonwealth of Pennsylvania, Department of Environmental Resources. The dam was constructed by Barto, Cox and Miller. Construction was completed in 1977.

h. Normal Operating Procedures. The reservoir is maintained at the spillway crest elevation with the excess inflow discharging over the spillway crest. During the spring and fall, the 48" drain is opened for inspection and lubrication.

1.3 Pertinent Data.

a. Drainage Area. 10.2 square miles

b. Discharge at Dam Site (cfs).

Maximum known flood at dam site	Approximately 500 cfs
	Spring 1979
48" drain line at normal pool elevation	220
Ungated spillway capacity at top of dam elevation 1090.1	11,694
Total spillway capacity at top of dam elevation 1090.1	11,914

c. Elevation (U.S.G.S. Datum) (feet). - Elevations worked from spillway crest elevation 1078.5 obtained from the construction drawings.

Top of dam - top of right spillway wingwall	1090.1
Top of dam - earth portion (low point)	1092.6
Design top of dam	1092.5
Maximum pool - design surcharge	1092.5
Full flood control pool	N/A
Normal pool	1078.5
Spillway crest	1078.5
Upstream portal - 48" drainline	1046.5
Downstream portal - 48" drainline	1044.5
Streambed at centerline of dam	1044.5
Maximum tailwater	None

d. Reservoir (feet).

Length of maximum pool	4200
Length of normal pool	4000

Length of flood control pool	N/A
e. <u>Storage (acre-feet).</u>	
Normal pool	949
Flood control pool	N/A
Design surcharge (embankment elev. 1902.5)	2425
Top of dam (1090.1 - top of wall)	2043
f. <u>Reservoir Surface (acres).</u>	
Top of dam (1090.1)	113
Maximum pool	113
Flood control pool	N/A
Normal pool	75
Spillway crest	75
g. <u>Dam.</u>	
Type	Earthfill
Length	500 feet
Height	49 feet
Top width	20 feet
Side slopes - Upstream	3H:1V
Downstream	2.5H:1V
Zoning	None
Impervious core	None
Cutoff	Core trench, partial cutoff
Grout curtain	None
h. <u>Reservoir Drain.</u>	
Type	48" concrete pipe
Length	270 feet
Closure	Valve in control tower
Access	From downstream endwall
Regulating facilities	Valve in control tower and 4" bypass valve on 48" pipe
i. <u>Spillway.</u>	
Type	Open cut trapezoid in earth approach with concrete ogee weir & concrete exit channel
Length	80 feet
Crest elevation	1078.5
Gates	None
Upstream channel	600 foot long open cut trapezoid
Downstream channel	230 foot concrete lined chute

SECTION 2  
ENGINEERING DATA

2.1 Design. Review of information in the files of the Commonwealth of Pennsylvania, Department of Environmental Resources revealed that construction drawings, design reports and permits were available. All this data was reviewed for this study.

2.2 Construction. Considerable information in the form of daily inspection reports are available for review.

2.3 Operation. No formal operating records are maintained on water levels and discharges.

2.4 Evaluation.

a. Availability. Engineering data were provided by PennDER Bureau of Dam Safety, Obstructions and Storm Water Management. The park superintendent accompanied the inspection team to answer questions on construction and operation of the dam.

b. Adequacy. The type and amount of design data and other engineering information is substantial. The information is sufficient to complete a Phase I Report.

SECTION 3  
VISUAL INSPECTION

3.1 Findings.

a. General. The onsite inspection of Stephen Foster Dam was conducted by personnel of L. Robert Kimball and Associates accompanied by the park superintendant on April 19, 1979. The inspection consisted of:

1. Visual inspection of the retaining structure, abutments and toe.
2. Examination of the spillway facilities, exposed portions of any outlet works and other appurtenant works.
3. Observations affecting the runoff potential of the drainage basin.
4. Evaluation of the downstream area hazard potential.

b. Dam. The dam appears to be in good condition. The dam appears to conform closely to the construction drawings. From a brief survey conducted during the inspection, it was noted that the crest of the dam is higher than the design height. Low points on the dam crest are at each abutment. However, the top of the right spillway wingwall is at elevation 1090.1 as designed. This is 2.5 feet lower than the low point on the dam. During flooding conditions, water will discharge over this right spillway wingwall before topping the crest of the dam. Discharges over this wingwall will flow down the abutment embankment contact and may cause severe erosion to the embankment (see page A-12).

The crest of the dam is twenty feet wide. The upstream slope of the embankment is 3H:1V and covered with riprap to elevation 1085 and is in good condition. The downstream slope of the embankment is 2.5H:1V and covered with grass and crown vetch. The downstream slope is not mowed because of the crown vetch. On the right abutment is a large seepage zone at elevation 1065.6. A small seepage zone exists along the riprap gutter on the right abutment at elevation 1074.7. Flow from these seepage zones flows into the rock gutter at the embankment-abutment contact. The flow enters a small pipe inlet at the low point of the ditch and flows into the drainline discharge channel. The seepage flowing in the riprap gutter was measured to be 19 gallons per minute.

c. Appurtenant Structures. The reservoir level at the time of the inspection was 1078.6. Approximately .1 feet of water was discharging over the spillway weir. The spillway weir is located approximately 200 feet downstream of the axis of the dam. All concrete associated with the spillway weir, discharge channel and stilling basin appears to be in very good condition. The spillway approach channel is cut in earth materials. The left wall of the spillway entrance channel was originally designed at a 2H:1V slope. After slides developed,

a wide bench was placed on this left cut. Along the backside of the bench is a sanitary sewer. Recently, many slides have occurred on the bench. These slides have a displacement of between 1 and 3 feet vertically and approximately 8 feet horizontally. These slides are moving downslope and are encroaching upon the spillway approach channel. The trash boom located upstream of the approach channel is broken and is not currently in use.

The 48" drainline was not operated during the inspection, however concrete at the outlet end appeared to be in good condition. The control structure was opened for inspection. The handles to operate the 48" drawdown conduit are not kept at the dam but are kept at the park superintendent's office.

d. Reservoir Area. The watershed is covered with woodland and farmland. The reservoir slopes are not considered to be susceptible to massive landslides which would affect the storage volume of the reservoir or overtopping of the dam by displacing water.

e. Downstream Channel. Immediately downstream of the dam is a culvert for an access road to the crest of the dam. During recent high water, this culvert collapsed and is inaccessible. Thus, the crest of the dam is inaccessible. Mill Creek downstream of the dam is narrow to moderately wide. The first downstream residence is located approximately 2.3 miles below the toe of the embankment. Approximately 3 miles downstream are approximately four residences and the Bradford County Home and Hospital.

3.2 Evaluation. In general, the embankment and appurtenant structures appear to be in very good condition and well maintained. The source of the seepage located on the right abutment should be further investigated to determine the long-term effect on the stability of the embankment. The slides located on the left spillway approach cut should be repaired. A large slide in this area could reduce the spillway capacity.

SECTION 4  
OPERATIONAL PROCEDURES

4.1 Procedures. The reservoir is maintained at as high a level as possible (spillway crest - elevation 1078.5). The reservoir drainline is exercised in the spring and fall of each year.

4.2 Maintenance of the Dam. No planned maintenance schedule is utilized. Maintenance of the dam is considered good.

4.3 Maintenance of Operating Facilities. The valves in the control tower are exercised and greased every six months. Maintenance of operating facilities is considered good.

4.4 Warning System in Effect. There is no warning system in effect.

4.5 Evaluation. Maintenance of the dam and operating facilities is considered good. There is no warning system in effect to warn downstream residents of large spillway discharges or failure of the dam.

SECTION 5  
HYDRAULICS AND HYDROLOGY

5.1 Evaluation of Features.

a. Design Data. Hydrology and hydraulic information are contained in the construction drawings. This data consists of a rating curve for the bypass valve, rating curve for the diversion conduit, rating curve for the spillway, drawdown curves and reservoir area capacity curves. The spillway is rated at 15,000 cfs at a reservoir elevation of 1092.5.

b. Experience Data. No rainfall, runoff or reservoir level data were available. The spillway reportedly has functioned adequately in the past. Maximum water level in the reservoir to date is reported to have been 1080.0 (approximately 500 cfs).

c. Visual Observations. The concrete in the spillway and spillway discharge channel is in good condition. The cut slope on the left spillway approach channel contains several active slides. These slides have approximately 1 to 3 feet vertical displacement and approximately 8 feet horizontal displacement. The slides are moving toward the spillway approach channel. A large slide in this area could partially block the spillway approach channel. Several slides have taken place to the left of the spillway discharge channel. The moving of this hillside has caused the left wingwall near the spillway weir to move and a joint has opened approximately 1.5 inches wide.

The right wingwall on the spillway near the spillway weir has a top elevation of 1090.1. This is approximately 2.5 feet below the crest of the dam. During high reservoir levels, water will flow over this wingwall before overtopping the dam. Some of the water flowing over the wingwall will flow along the embankment-abutment contact and may cause severe erosion to the embankment.

d. Overtopping Potential. Overtopping potential was investigated through the development of the probable maximum flood (PMF) for the watershed and the subsequent routing of the PMF and fractions of the PMF through the reservoir and spillway.

The Corps of Engineers, Baltimore District, has directed that the HEC-1 Dam Safety Version systemized computer program be utilized. The program was prepared by the Hydrologic Engineering Center (HEC), U.S. Army Corps of Engineers, Davis, California, July, 1978. The major methodologies or key input data for this program are discussed briefly in Appendix D.

5.2 Evaluation Assumptions. To enable us to complete the hydraulic and hydrologic analysis for this structure, it was necessary to make the following assumptions.

1. The water level in the reservoir prior to flood was at the spillway crest elevation 1078.5.

2. The low point on the top of dam was considered to be the top of the right spillway wingwall elevation 1090.1. Flow over this wingwall will cause water to run along the left embankment-abutment contact and may cause serious erosion and eventually jeopardize the stability of the embankment.

5.3 Summary of Overtopping Analysis. Complete summary sheets from the computer output are presented in Appendix D.

Peak inflow - 14,063 cfs  
Spillway capacity - 11,694 cfs

a. Spillway Adequacy Rating. The Spillway Design Flood (SDF) for this dam is the PMF. The SDF is based upon the hazard and size classification of the dam. Based on the following definition provided by the Corps of Engineers, this spillway is rated as inadequate as a result of our hydrologic analysis.

Inadequate - Intermediate size dams which do not pass the PMF but which do pass 50% of the PMF.

The spillway and reservoir are capable of controlling approximately 71% of the PMF without overtopping the embankment. If the right spillway wingwall were raised to the design top of dam height (elevation 1092.5) the reservoir and spillway would be capable of controlling a larger percent of the PMF without overtopping.

SECTION 6  
STRUCTURAL STABILITY

6.1 Evaluation of Structural Stability.

a. Visual Observations. The source of the seepage on the right abutment should be further investigated. The long-term effect of this seepage is uncertain. The high seepage level may eventually saturate the embankment near the abutment and reduce the stability of the embankment. The seepage was noted shortly after reservoir filling. With high heads during flooding the seepage could increase substantially and piping develop.

b. Design and Construction Data. No record of design data or stability analysis for the original structure was available for review.

c. Operating records. There are no operating records for the dam.

d. Post-Construction Changes. There have been no post-construction changes to the dam. The cut on the left spillway approach channel was modified to include a bench for stabilization of the cut slope.

e. Seismic Stability. The dam is located in seismic zone 1. No seismic stability analysis has been performed. Normally, it can be considered that if a dam in this zone is stable under static loading conditions, it can be assumed safe for any expected earthquake loading.

SECTION 7  
ASSESSMENT AND RECOMMENDATIONS/REMEDIAL MEASURES

7.1 Dam Assessment.

a. Safety. The dam appears to be in good condition. The visual observations, review of available information, hydrologic calculations, and past operational performance indicate that Stephen Foster Dam's spillway is inadequate. The spillway is capable of controlling approximately 71% of the PMF without overtopping. No stability analysis has been performed. The long-term effect of the stability is uncertain due to the seepage on the right abutment. The source of this seepage should be determined and seepage should be monitored at regular intervals.

b. Adequacy of Information. Sufficient information is available to complete a Phase I report.

c. Urgency. The recommendations suggested below should be implemented immediately.

d. Necessity for Further Investigation. In order to accomplish some of the recommendations/remedial measures outlined below, further investigations will be required.

7.2 Recommendations/Remedial Measures.

1. The right spillway wingwall of the spillway weir should be raised to a minimum elevation of 1092.5. Raising this wingwall will increase the spillway capacity substantially.

2. The services of a professional engineer knowledgeable in dam design should be retained to evaluate the effect of the seepage exiting from the right abutment. In addition, a v-notch weir should be installed to collect the seepage. The flow should be measured and recorded periodically and the turbidity observed.

3. The left spillway approach channel slope should be stabilized to prevent the approach from being blocked by a future slide.

4. Institute a formal inspection program to be conducted at regular intervals.

5. A warning system should be instituted to warn downstream residences of high spillway discharges, during periods of heavy rainfall or heavy runoff or failure of the dam.

6. Access to the dam should be improved so the dam is accessible during periods of flooding. Access should be provided to the top of the dam. A bridge over the spillway should be considered.

7. The trash boom should be repaired.

APPENDIX A

CHECKLIST, VISUAL INSPECTION, PHASE I

CHECK LIST  
VISUAL INSPECTION  
PHASE I

NAME OF DAM Stephen Foster Dam COUNTY Bradford STATE Pennsylvania ID# PA-906  
TYPE OF DAM Earthfill HAZARD CATEGORY High  
DATE(S) INSPECTION April 19, 1979 WEATHER Clear, cool TEMPERATURE 60°F  
POOL ELEVATION AT TIME OF INSPECTION 1078.6 M.S.L. TAILWATER AT TIME OF INSPECTION None M.S.L.

INSPECTION PERSONNEL:

R. Jeffrey Kimball, L. Robert Kimball & Associates  
James T. Hockensmith, L. Robert Kimball & Associates  
Kuang-hwei Chuang, L. Robert Kimball & Associates  
Dave Rutkowski, Park Superintendent

James T. Hockensmith RECORDER

**EMBANKMENT**

VISUAL EXAMINATION OF	OBSERVATIONS	REMARKS OR RECOMMENDATIONS
SURFACE CRACKS	None.	
UNUSUAL MOVEMENT OR CRACKING AT OR BEYOND THE TOE	None.	
SLOUCHING OR EROSION OF EMBANKMENT AND ABUTMENT SLOPES	Severe slope problem on left spillway cut slope. Maximum vertical displacement - 3 feet. Maximum horizontal displacement - 8 feet toward spillway approach channel.	
VERTICAL AND HORIZONTAL ALIGNMENT OF THE CREST	Horizontal alignment is good. Vertical alignment - low points on abutment, high point in center of dam. All points above design crest elevation. Low point of right spillway wingwall - elevation 1090.1.	
RIPRAP FAILURES	None.	

**EMBANKMENT**

VISUAL EXAMINATION OF	OBSERVATIONS	REMARKS OR RECOMMENDATIONS
<b>VEGETATION</b>	Grass and crown vetch on downstream slope.	
<b>JUNCTION OF EMBANKMENT AND ABUTMENT, SPILLWAY AND DAM</b>	Left abutment appears good. Right abutment - seepage exiting (see below).	
<b>ANY NOTICEABLE SEEPAGE</b>	Seepage exiting at elev. 1065.6 and a minor spot at 1074.71. This seepage runs along the embankment-abutment contact in a riprap gutter to a low point and enters a pipe and exits at the drainage conduit discharge channel. The seepage was measured at a point in the riprap gutter and to be 19 gpm.	
<b>STAFF GAUGE AND RECORDER</b>	Yes. Near right abutment in reservoir.	
<b>DRAINS</b>	Construction drawings show a toe drain in the embankment. This toe drain exits at the draw-down conduit endwall. No seepage was noted out of this pipe during the inspection.	

**CONCRETE/MASONRY DAMS**

<b>VISUAL EXAMINATION OF</b>	<b>OBSERVATIONS</b>	<b>REMARKS OR RECOMMENDATIONS</b>
ANY NOTICEABLE SEEPAGE	N/A	
STRUCTURE TO ABUTMENT/EMBANKMENT JUNCTIONS	N/A	
DRAINS	N/A	
WATER PASSAGES	N/A	
FOUNDATION	N/A	

**CONCRETE/MASONRY DAMS**

<b>VISUAL EXAMINATION OF</b>	<b>OBSERVATIONS</b>	<b>REMARKS OR RECOMMENDATIONS</b>
SURFACE CRACKS CONCRETE SURFACES	N/A	
STRUCTURAL CRACKING	N/A	
VERTICAL AND HORIZONTAL ALIGNMENT	N/A	
MONOLITH JOINTS	N/A	
CONSTRUCTION JOINTS	N/A	
STAFF GAUGE OR RECORDER	N/A	

**OUTLET WORKS**

VISUAL EXAMINATION OF	OBSERVATIONS	REMARKS OR RECOMMENDATIONS
CRACKING AND SPALLING OF CONCRETE SURFACES IN OUTLET CONDUIT	The 48" drainage conduit was unobserved except at the discharge end. At the discharge end, the concrete appeared to be in good condition.	
INTAKE STRUCTURE	Unobserved. It is located at the upstream toe of the embankment.	
OUTLET STRUCTURE	Outlet structure appeared to be in good condition.	
OUTLET CHANNEL	Outlet channel was in good condition. Riprap side slopes.	
EMERGENCY GATE	The valve to control the 48" pipeline was unobserved.	

**UNGATED SPILLWAY**

VISUAL EXAMINATION OF	OBSERVATIONS	REMARKS OR RECOMMENDATIONS
CONCRETE WEIR	Good condition.	
APPROACH CHANNEL	Approximately 600 feet long. Approach channel left cut slope has severe slide problem.	
DISCHARGE CHANNEL	Concrete paved chute. Concrete in good condition. Slides on left slope of discharge channel.	
BRIDGE AND PIERS	None.	

**GATED SPILLWAY**

<b>VISUAL EXAMINATION OF</b>	<b>OBSERVATIONS</b>	<b>REMARKS OR RECOMMENDATIONS</b>
<b>CONCRETE SILL</b>	N/A	
<b>APPROACH CHANNEL</b>	N/A	
<b>DISCHARGE CHANNEL</b>	N/A	
<b>BRIDGE AND PIERS</b>	N/A	
<b>GATES AND OPERATION EQUIPMENT</b>	N/A	

**DOWNSTREAM CHANNEL**

VISUAL EXAMINATION OF	OBSERVATIONS	REMARKS OR RECOMMENDATIONS
<p style="text-align: center;"><b>CONDITION (OBSTRUCTIONS, DEBRIS, ETC.)</b></p>	<p>Narrow to moderately wide. Immediately below dam is an access road culvert which was destroyed during recent high discharges. This culvert and roadway were overtopped and the slope has failed.</p>	
<p style="text-align: center;"><b>SLOPES</b></p>	<p style="text-align: center;">Stable.</p>	
<p style="text-align: center;"><b>APPROXIMATE NO. OF HOMES AND POPULATION</b></p>	<p>Approximately five homes and the Bradford County Home and Hospital within 3.5 miles of the toe of the dam. Approximately 100 people live within this region.</p>	

**RESERVOIR**

<b>VISUAL EXAMINATION OF</b>	<b>OBSERVATIONS</b>	<b>REMARKS OR RECOMMENDATIONS</b>
<b>SLOPES</b>	Moderately steep, stable.	
<b>SEDIMENTATION</b>	Minor, reservoir is new.	

**INSTRUMENTATION**

VISUAL EXAMINATION OF	OBSERVATIONS	REMARKS OR RECOMMENDATIONS
MONUMENTATION/SURVEYS	None.	
OBSERVATION WELLS	None.	
WEIRS	None.	
PIEZOMETERS	None.	
OTHER	None.	



**CHECK LIST**  
**ENGINEERING DATA**  
**DESIGN, CONSTRUCTION, OPERATION**  
**PHASE I**

NAME OF DAM Stephen Foster Dam

ID# PA - 906

ITEM	REMARKS
AS-BUILT DRAWINGS	None.
REGIONAL VICINITY MAP	U.S.G.S. Quadrangle and on construction drawings.
CONSTRUCTION HISTORY	Daily construction reports in the Commonwealth of Pennsylvania files.
TYPICAL SECTIONS OF DAM	Construction drawings.
OUTLETS - PLAN - DETAILS - CONSTRAINTS - DISCHARGE RATINGS RAINFALL/RESERVOIR RECORDS	None.
	None.

ITEM	REMARKS
DESIGN REPORTS	Commonwealth of Pennsylvania files.
GEOLOGY REPORTS	None.
DESIGN COMPUTATIONS HYDROLOGY & HYDRAULICS DAM STABILITY SEEPAGE STUDIES	None.
MATERIALS INVESTIGATIONS BORING RECORDS LABORATORY FIELD	Construction drawings.
POST-CONSTRUCTION SURVEYS OF DAM	None.
BORROW SOURCES	Spillway channel.

ITEM	REMARKS
MONITORING SYSTEMS	None.
MODIFICATIONS	None except to the spillway approach channel cut.
HIGH POOL RECORDS	None.
POST CONSTRUCTION ENGINEERING STUDIES AND REPORTS	None.
PRIOR ACCIDENTS OR FAILURE OF DAM DESCRIPTION REPORTS	None.
MAINTENANCE OPERATION RECORDS	None.

ITEM	REMARKS
SPILLWAY PLAN SECTIONS DETAILS	Construction Drawings.
OPERATING EQUIPMENT PLANS & DETAILS	Construction Drawings.

APPENDIX C  
PHOTOGRAPHS



Upstream slope and drain control structure from left abutment.

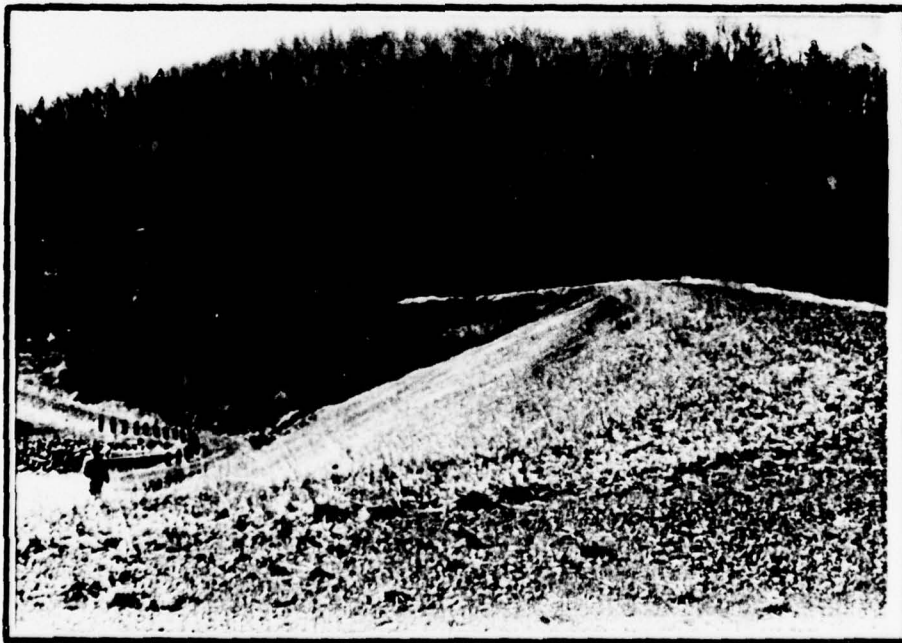

Downstream slope from spillway area.

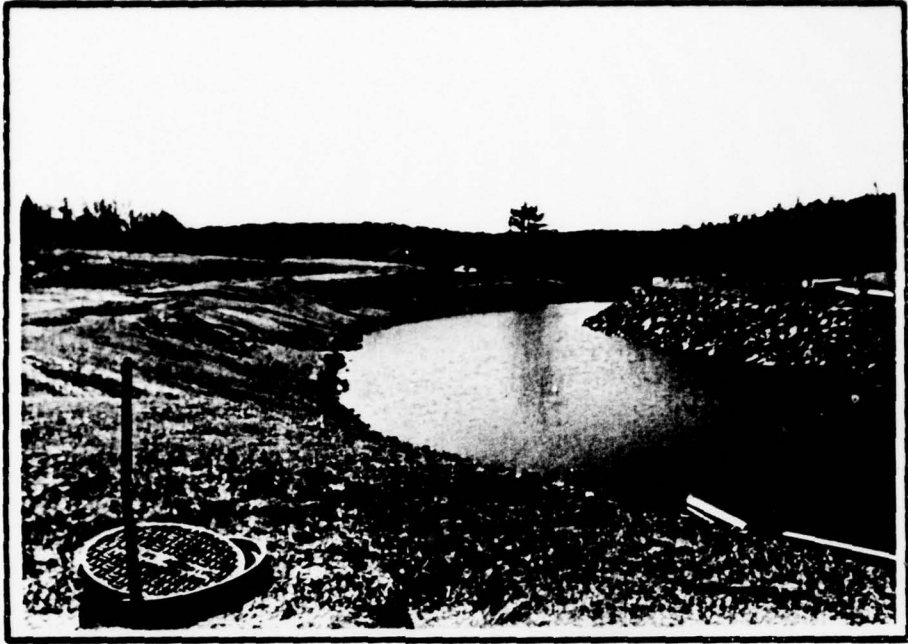

Spillway approach channel.  
Note: slides on left abutment.

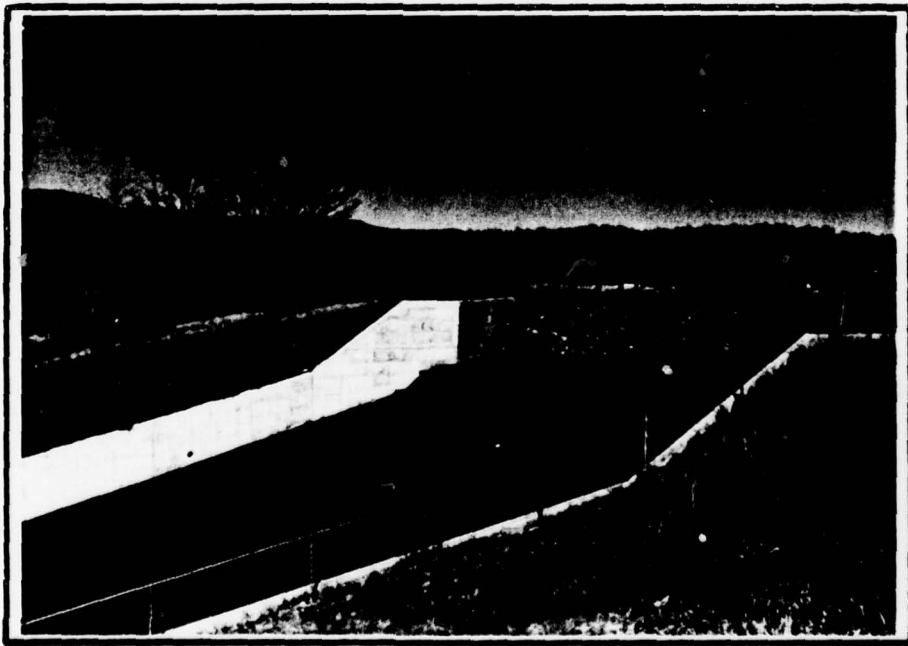

Spillway weir.

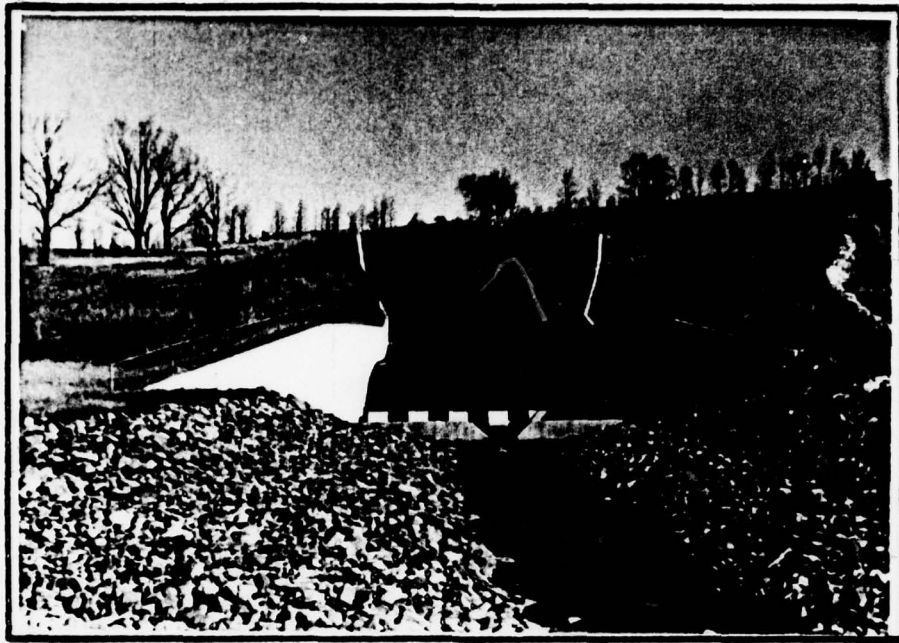

Spillway exit channel.

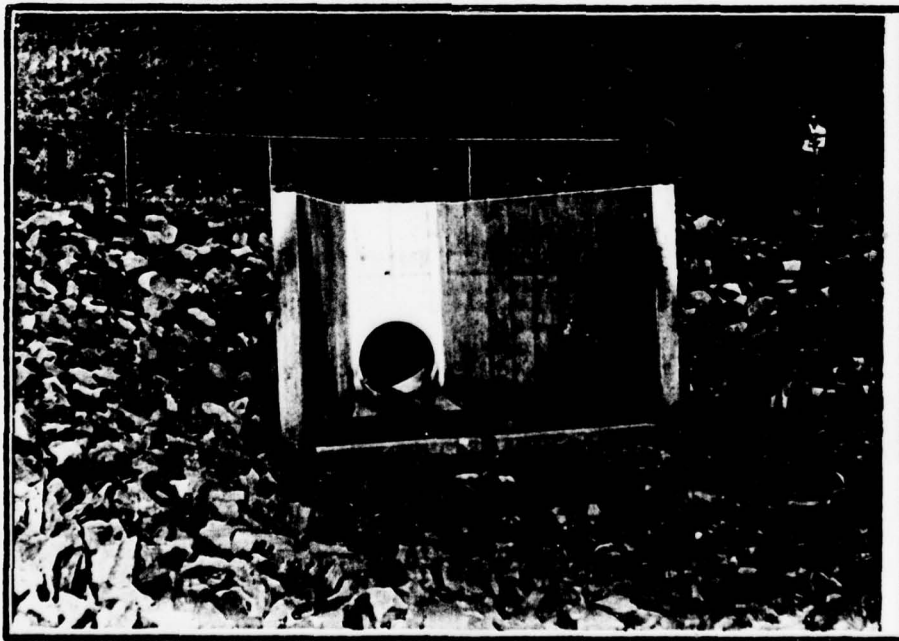

Endwall on reservoir drain.



Slides on left highwall of spillway approach.



Slides on left highwall of spillway approach.

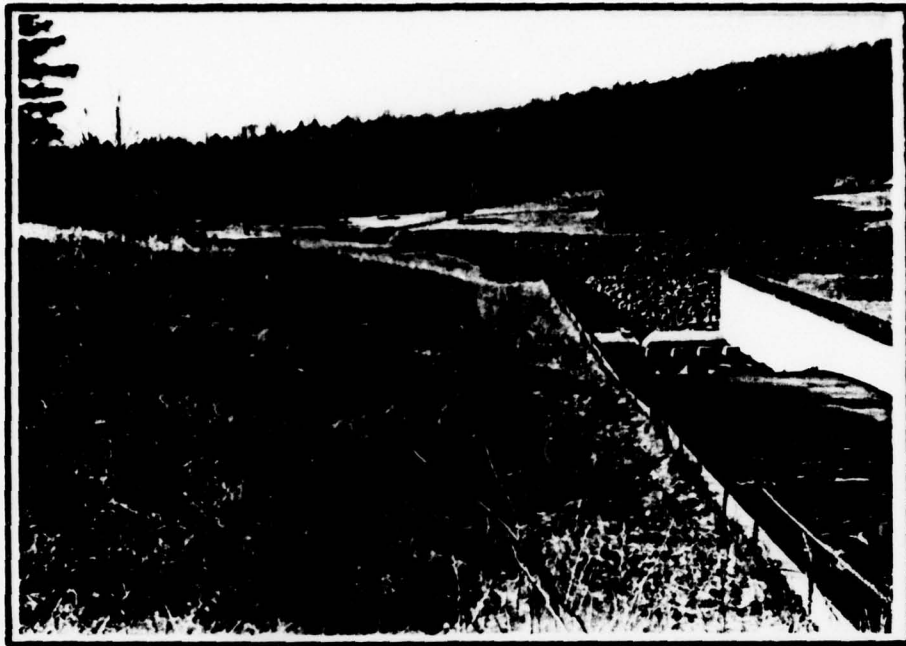

Immediate downstream view.  
Note: slides to left of spillway exit channel.



Damaged access road crossing.



First downstream residence.

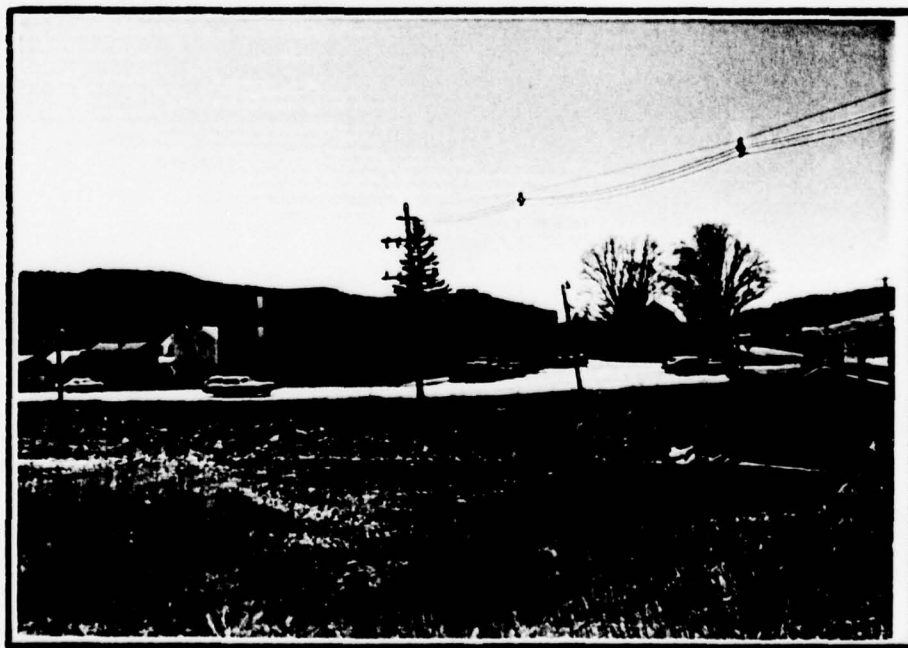

Homes and hospital downstream.

APPENDIX D  
HYDROLOGY AND HYDRAULICS

Methodology. The dam overtopping and breach analyses were accomplished using the systemized computer program HEC-1 (Dam Safety Investigation), September, 1978, prepared by the Hydrologic Engineering Center, U.S. Army Corps of Engineers, Davis, California. A brief description of the methodology used in the analysis is presented below.

1. Precipitation. The Probable Maximum Precipitation (PMP) is derived and determined from regional charts prepared from past rainfall records including "Hydrometeorological Reports No. 40 prepared by the National Weather Service.

The index rainfall is reduced from 10% to 20% depending on watershed size by utilization of what is termed the HOP Brook adjustment factor. Distribution of the total rainfall is made by the computer program using distribution methods developed by the Corps.

2. Inflow Hydrograph. The hydrologic analysis used in development of the overtopping potential is based on applying a hypothetical storm to a unit hydrograph to obtain the inflow hydrograph for reservoir routing.

The unit hydrograph is developed using the Snyder method. This method requires calculation of several key parameters. The following list gives these parameters their definition and how they were obtained for these analysis.

Parameter	Definition	Where Obtained
$C_t$	Coefficient representing variations of watershed slope and storage	From Corps of Engineers*
L	Length of main stream channel miles	From U.S.G.S. 7.5 minute topographic
$L_{ca}$	Length on main stream to centroid of watershed	From U.S.G.S. 7.5 minute topographic
$C_p$	Peaking coefficient	From Corps of Engineers*
A	Watershed size	From U.S.G.S. 7.5 minute topographic

\*Developed by the Corps of Engineers on a regional basis for Pennsylvania.

3. Routing. Reservoir routing is accomplished by using Modified Plus routing techniques where the flood hydrograph is routed through reservoir storage. Hydraulic capacities of the outlet works, spillways and the crest of the dam are used as outlet controls in the routing.

The hydraulic capacity of the outlet works can either be calculated and input or sufficient dimensions input and the program will calculate an elevation discharge relationship.

Storage in the pool area is defined by an area - elevation relationship from which the computer calculates storage. Surface areas are either planimetered from available mapping or U.S.G.S. 7.5 minute series topographic maps or taken from reasonably accurate design data.

4. Dam Overtopping. Using given percentages of the PMF the computer program will calculate the percentage of the PMF which can be controlled by the reservoir and spillway without the dam overtopping.



L. ROBERT KIMBALL & ASSOCIATES  
CONSULTING ENGINEERS & ARCHITECTS  
EBENSBURG PENNSYLVANIA

DAM NAME STEPHEN FOSTER DAM

I.D. NUMBER PL. 8-59

SHEET NO. 1 OF 2

BY OTM DATE 5-3-79

STEPHEN FOSTER DAM

DRAINAGE AREA

AREA = 10.2 mi<sup>2</sup> (FROM U.S.G.S. 7.5 MINUTE QUAD.)

UNIT HYDROGRAPH PARAMETERS

DAM SITE LOCATED IN ZONE #11, SUSQUEHANNA RIVER BASIN. FROM CORPS OF ENGINEERS, BALTIMORE DISTRICT REGIONAL STUDY.

$C_p = 0.62$ ,  $C_t = 1.50$

$L = 8.8$  mi.,  $L_{ca} = 2.7$  mi. (USGS 7.5 MIN. QUAD)

$t_p = C_t (L \times L_{ca})^{0.3} = 1.5 (8.8 \times 2.7)^{0.3}$

$t_p = 3.9$  HRS. (SNYDERS LAG ( $t_p$ ) IN HRS.)

LOSS RATE AND BASE FLOW PARAMETERS

AS RECOMMENDED BY CORPS OF ENGINEERS, BALTIMORE DISTRICT.

STR TL = 1 INCH

CNSTL = 0.05 IN/HR

STR TQ = 1.5 cfs/mi<sup>2</sup>

QRCSN = 0.05 (5% OF PEAK FLOW)

RTIOR = 2.00

PROBABLE MAXIMUM STORM

FROM H. R. NO. 40

PMP, INDEX RAINFALL -  $22.2(0.95) = 21.2$  IN.

$R_6 = 117\%$ ,  $R_{12} = 127\%$ ,  $R_{24} = 136\%$ ,  $R_{48} = 142\%$ ,  $R_{72} = 145\%$



L. ROBERT KIMBALL & ASSOCIATES  
CONSULTING ENGINEERS & ARCHITECTS  
EBENSBURG PENNSYLVANIA

DAM NAME STEPHEN FOSTER DAM

I.D. NUMBER PA. 8-59

SHEET NO. 2 OF 2

BY OTM DATE 5-3-79

ELEVATION - AREA - CAPACITY RELATIONSHIPS

FROM U.S.G.S. 7.5 MIN. QUAD, FIELD INSPECTION DATA AND DER FILES.

AT SPILLWAY CREST, ELEV. 1078.5'

AREA = 79 ACRES

INITIAL STORAGE = 922 AC.FT

AT 1080', AREA = 96 ACRES

AT 1100', AREA = 167 ACRES

FROM CONIC METHOD FOR RESERVOIR VOLUME. FLOOD HYDROGRAPH PACKAGE (HEC-1). DAM SAFETY VERSION (USERS MANUAL).

$$H = 3V/A = 3(922)/79 = 35.0'$$

ELEV. AT CAPACITY EQUALS ZERO;

$$1078.5' - 35' = 1043.5'$$

ELEV. (FT.)	1043.5	1055	1060	1068	1074	1080	1086	1091.5	1100
AREA (AC.)	0	10	20	40	60	80	100	120	150

DISCHARGE RATING CURVES

DISCHARGE RATING CURVES WERE DETERMINED WITH (HEC-1) BASED ON THE FOLLOWING PARAMETERS.

SECTION	WEIR LENGTH (FT.)	C
SPILLWAY	80	3.7 (OGEE)
DAM	640	3.0 (BROAD CREST.)

SPILLWAY CREST ELEVATION AT 1078.5'

TOP OF DAM ELEVATION AT 1090.1'

CHECK LIST  
HYDROLOGIC AND HYDRAULIC  
ENGINEERING DATA

DRAINAGE AREA CHARACTERISTICS: 10.2 Square miles, wooded and farmland  
ELEVATION TOP NORMAL POOL (STORAGE CAPACITY): 1078.5 (949 acre-feet)  
ELEVATION TOP FLOOD CONTROL POOL (STORAGE CAPACITY): N/A  
ELEVATION MAXIMUM DESIGN POOL: 1092.5  
ELEVATION TOP DAM: 1090.1 (top of left spillway wingwall)

SPILLWAY CREST:

a. Elevation 1078.5  
b. Type ogee-weir  
c. Width N/A  
d. Length 80 feet  
e. Location Spillover Left abutment  
f. Number and Type of Gates None

OUTLET WORKS:

a. Type 48" concrete pipe  
b. Location Through dam  
c. Entrance inverts 1046.5  
d. Exit inverts 1044.5  
e. Emergency draindown facilities Valve in control tower

HYDROMETEOROLOGICAL GAUGES:

a. Type None  
b. Location \_\_\_\_\_  
c. Records \_\_\_\_\_

MAXIMUM NON-DAMAGING DISCHARGE: 500 cfs elevation 1090.0, spring 1979



\*\*\*\*\*  
 FLOOD HYDROGRAPH PACKAGE (HEC-1)  
 DAM SAFETY VERSION JULY 1978  
 LAST MODIFICATION 26 FEB 79  
 \*\*\*\*\*

RUN DATE 79/04/27  
 TIME 13:57:36

ANALYSIS OF DAM OVERTOPPING USING RATIOS OF PMF  
 HYDROLOGIC-HYDRAULIC ANALYSIS OF STEPHEN FOSTER DAM PA 8-59  
 RATIOS OF PMF ROUTED THROUGH THE RESERVOIR

NO.	NHR	NMIN	IDAY	IHR	IMIN	METRC	IPLT	IPRT	NSTAN
288	0	15	0	0	0	0	0	0	0

JOB SPECIFICATION

JOPER 5  
 MWT 0  
 LRPT 0  
 TRACE 0

MULTI-PLAN ANALYSES TO BE PERFORMED

PLANES 1 MILLION 9 LITERS  
 10 20 30 40 50 60 70 80 90 100

\*\*\*\*\*

SUB-AREA RUNOFF COMPUTATION

INFLOW TO RESERVOIR

ISTAQ	ICOMP	IECON	ITAPE	JPLT	JPRT	INAME	ISTAGE	IAUTU
1	0	0	0	0	0	1	0	0

HYDROGRAPH DATA



HYDROGRAPH ROUTING

ROUTE THROUGH RESERVOIR

ISTAG	IComp	IECON	ITAPE	IPLT	IPRT	INAME	ISTAGE	IAUTD
2	1	0	0	0	0	1	0	0
ROUTING DATA								
QLOSS	CLOSS	AVG	INES	ISAME	IOPT	IPMP	LSTR	
0.0	0.000	0.00	1	1	0	0	0	

NSIPS	MSIDL	LAG	AMSKK	STORA	ISPHAT
1	0	0	0.000	0.000	0

SURFACE AREA	0.	10.	20.	30.	40.	50.	60.	70.	75.	80.
	0.	100.	110.	120.	123.	150.	60.	70.	75.	80.

CAPACITY	0.	10.	20.	30.	40.	50.	60.	70.	75.	80.
	0.	1320.	1605.	112.	224.	227.	340.	335.	640.	1065.

ELEVATION	1044.	1055.	1060.	1065.	1068.	1071.	1074.	1077.	1079.	1080.
	1083.	1086.	1089.	1092.	1093.	1100.				

CREST LENGTH	50'	140.	240.	640.
AT OR BELOW ELEVATION	1090.1	1092.6	1093.4	1093.6

PEAK OUTFLOW IS	331.	AI TIME	51.00 HOURS
PEAK OUTFLOW IS	336.1	AI TIME	45.75 HOURS

TOPEL	COOD	EXPD	DAMWID
1090.1	3.0	1.5	640.

DAM DATA
TOPEL
COOD
EXPD
DAMWID

CREST LENGTH	50'	140.	240.	640.
AT OR BELOW ELEVATION	1090.1	1092.6	1093.4	1093.6

PEAK OUTFLOW IS	331.	AI TIME	51.00 HOURS
PEAK OUTFLOW IS	336.1	AI TIME	45.75 HOURS

TOPEL	COOD	EXPD	DAMWID
1090.1	3.0	1.5	640.

DAM DATA
TOPEL
COOD
EXPD
DAMWID

PEAK OUTFLOW IS 4384. AT TIME 45.00 HOURS

PEAK OUTFLOW IS 6249. AT TIME 44.50 HOURS

PEAK OUTFLOW IS 8026. AT TIME 44.25 HOURS

PEAK OUTFLOW IS 9775. AT TIME 44.25 HOURS

PEAK OUTFLOW IS 11489. AT TIME 44.25 HOURS

PEAK OUTFLOW IS 13259. AT TIME 44.25 HOURS

PEAK OUTFLOW IS 16918. AT TIME 44.00 HOURS

PEAK FLOW AND STORAGE (END OF PERIOD) SUMMARY FOR MULTIPLE PLAN-RATIO ECONOMIC COMPUTATIONS  
 FLOWS IN CUBIC FEET PER SECOND (CUBIC METERS PER SECOND)  
 AREA IN SQUARE MILES (SQUARE KILOMETERS)

OPERATION RATIO 9	STATION	AREA	PLAN	RATIOS APPLIED TO FLOWS							
				RATIO 1	RATIO 2	RATIO 3	RATIO 4	RATIO 5	RATIO 6	RATIO 7	RATIO 8
1	10.20	1	1758.	3516.	5274.	7031.	8789.	10547.	12305.	14063.	
HYDROGRAPH AT 17579.	( 26.42)	( 49.78)	( 99.55)	( 149.33)	( 199.11)	( 248.88)	( 298.66)	( 348.44)	( 398.21)	( 448.00)	
497.77)											
ROUTED TO 16918.	2	10.80	331.	2308.	3382.	4466.	5550.	6634.	7718.	8802.	
479.08)	( 26.42)	( 9.36)	( 67.84)	( 124.13)	( 176.96)	( 227.27)	( 276.79)	( 325.33)	( 375.44)	( 425.55)	

SUMMARY OF DAM SAFETY ANALYSIS

PLAN 1 .....

ELEVATION STORAGE INITIAL VALUE SPILLWAY CREST TOP OF DAM  
 1079.58 1082.53 1043.50 1078.50 1090.10  
 0. 0. 949. 2043.  
 OUTFLOW 0. 0. 1694.

RATIO OF PNE	MAXIMUM RESERVOIR W.S.-ELEV	MAXIMUM DEPTH OVER DAM	MAXIMUM STORAGE AC=EI	MAXIMUM OUTFLOW CFS	DURATION OVER TOP HOURS	MAX OUTFLOW HOURS	TIME OF FAILURE HOURS
.10	1079.58	0.00	1031.	331.	0.00	5.00	0.00
.20	1082.53	0.00	1278.	396.	0.00	5.17	0.00
.30	1084.53	0.00	1461.	438.	0.00	45.00	0.00
.40	1086.14	0.00	1619.	624.	0.00	44.50	0.00
.50	1087.53	0.00	1761.	802.	0.00	44.25	0.00
.60	1088.79	0.00	1897.	977.	0.00	44.25	0.00
.70	1089.96	0.00	2027.	1149.	0.00	44.25	0.00
.80	1091.01	.51	2148.	1328.	1.450	44.25	0.00
1.00	1092.69	2.59	2352.	1698.	4.50	44.00	0.00

APPENDIX E

DRAWINGS

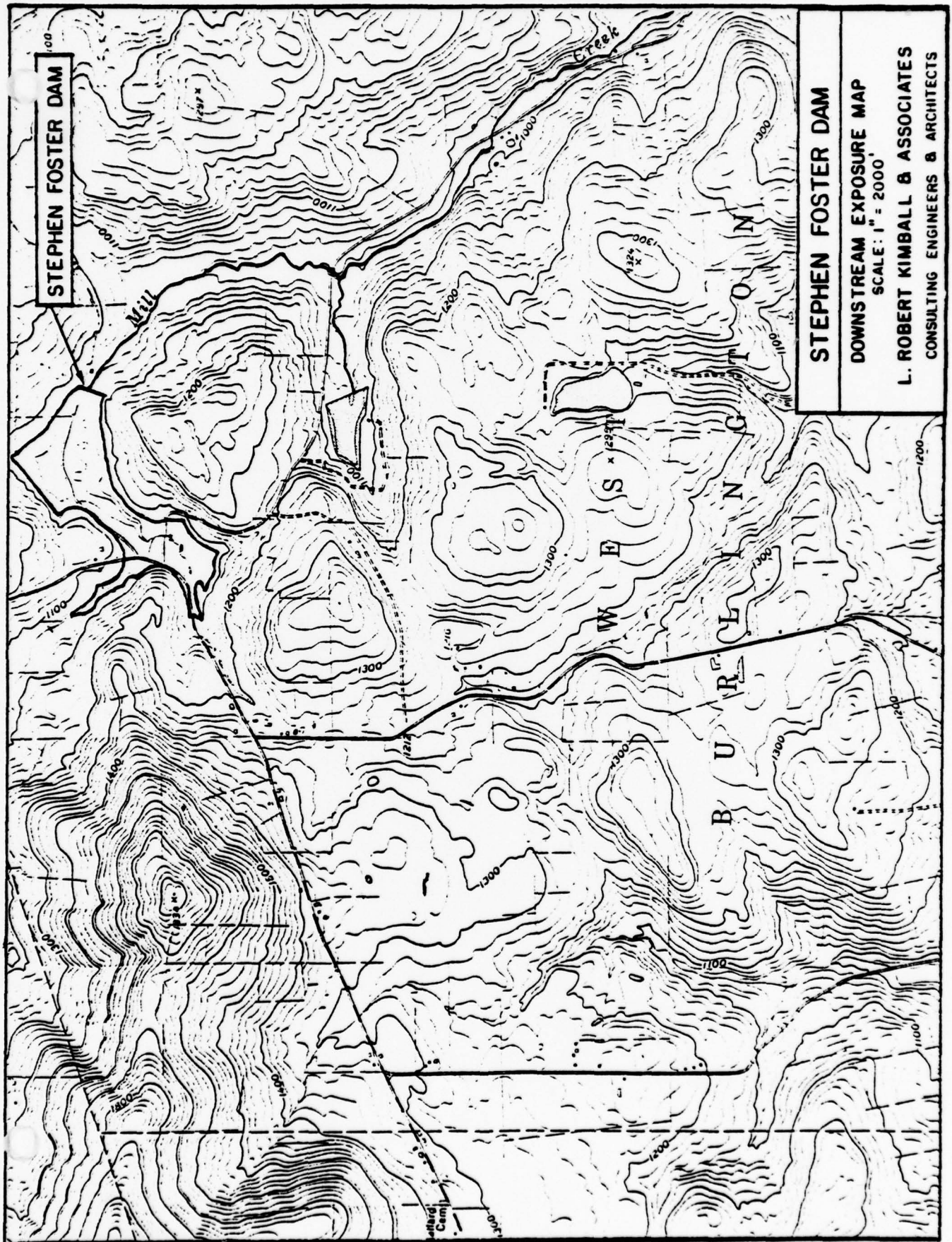
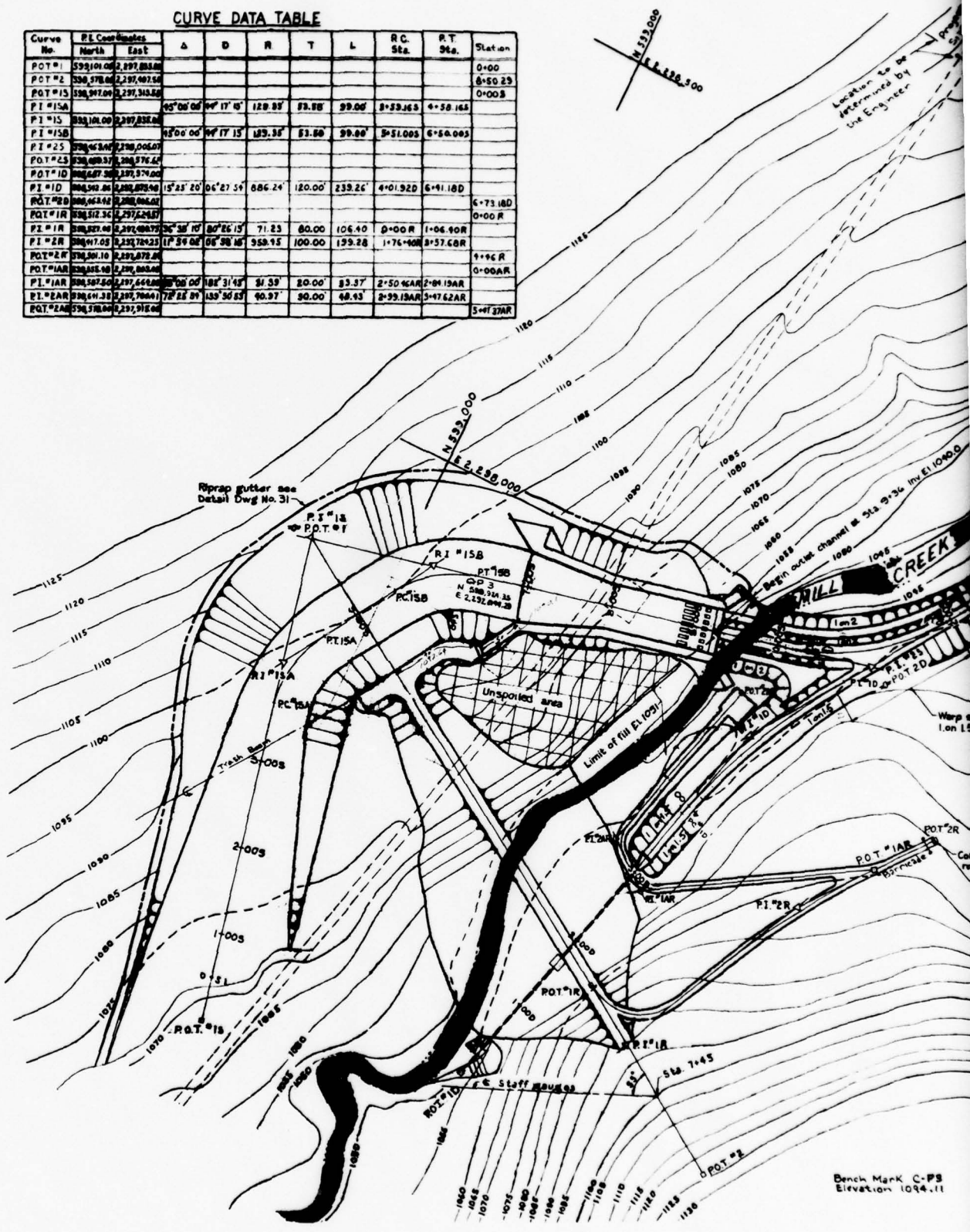

FIGURE 1

CURVE DATA TABLE

Curve No.	P.E. Coordinates		Δ	D	R	T	L	RC Sta.	PT Sta.	Station
	North	East								
POT #1	599,010.00	2,297,003.00								0+00
POT #2	599,378.00	2,297,402.50								6+50.23
POT #13	599,972.00	2,297,343.50								0+00.3
PI #15A			45°00'00"	17' 10"	129.85'	89.88'	99.00'	3+39.165	4+58.165	
PI #15	599,101.00	2,297,832.00								
PI #15B			45°00'00"	17' 15"	129.35'	83.80'	99.80'	3+51.005	6+50.005	
PI #25	599,463.00	2,298,006.00								
POT #23	599,083.50	2,298,376.45								
POT #10	599,667.50	2,297,974.00								
PI #10	599,502.00	2,298,075.00	15°25' 20"	06' 27' 54"	686.24'	120.00'	233.26'	4+01.920	6+41.180	
POT #20	599,464.00	2,298,064.00								6+73.180
POT #18	599,512.30	2,297,624.00								0+00.8
PI #18	599,827.00	2,297,081.75	36° 30' 10"	00' 26' 15"	71.83'	80.00'	106.40'	0+00.8	1+06.908	
PI #28	599,917.05	2,297,781.25	11° 34' 00"	06' 30' 18"	958.75'	100.00'	199.28'	1+76+908	3+57.608	
POT #28	599,301.10	2,297,078.00								1+16.8
POT #18R	599,858.00	2,297,083.00								0+00.8R
PI #18R	599,587.50	2,297,644.00	30° 00' 00"	18' 31' 45"	81.39'	80.00'	83.37'	2+50+648	2+01.198	
PI #28R	599,611.30	2,297,786.41	72° 25' 00"	13' 30' 53"	90.37'	90.00'	68.93'	3+33.188	3+47.628	
POT #28R	599,378.00	2,297,918.00								5+47.288



Bench Mark C-PS  
Elevation 1094.11



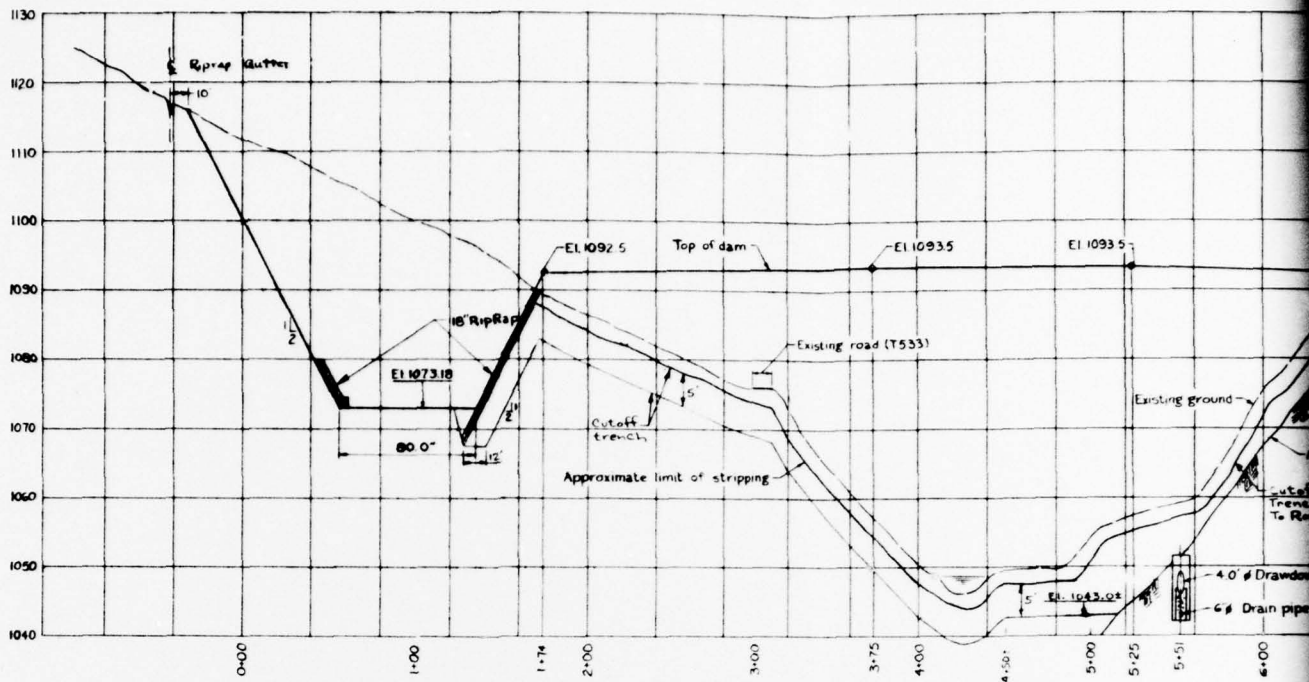

**PROFILE**  
 Scale: Hor 1 in = 40 ft  
 Vert 1 in = 10 ft

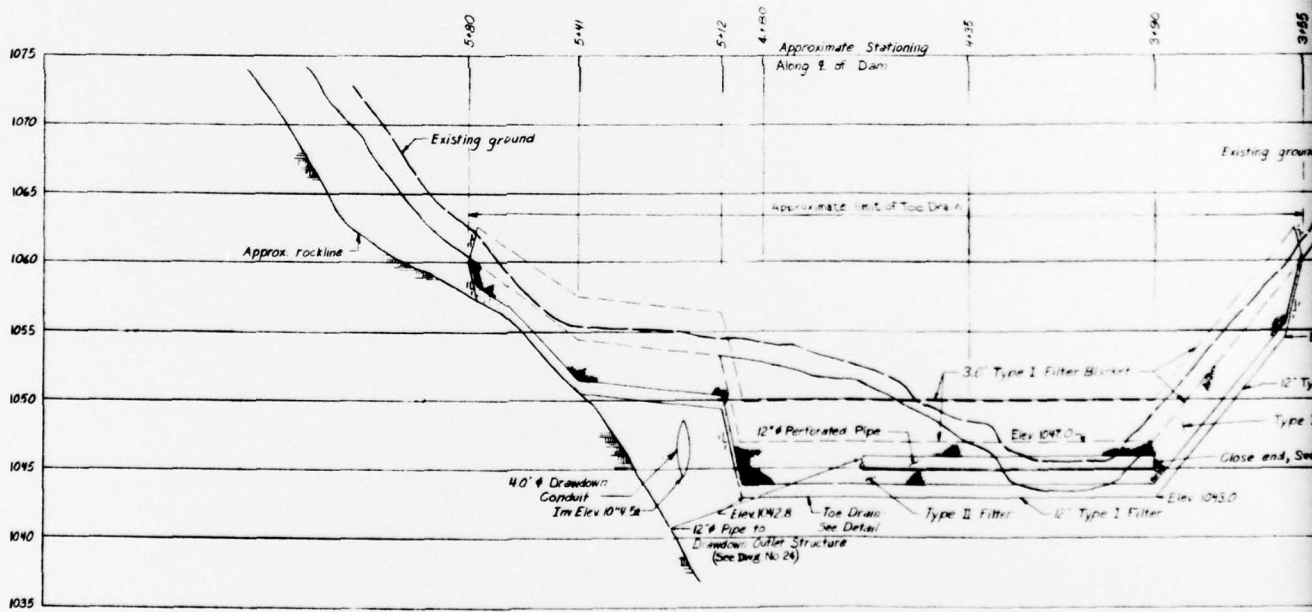

**PROFILE ALONG § OF TOE DRAIN - LOOKING UPSTREAM**

Scale: Hor 1 in = 20 ft  
 Vert 1 in = 10 ft

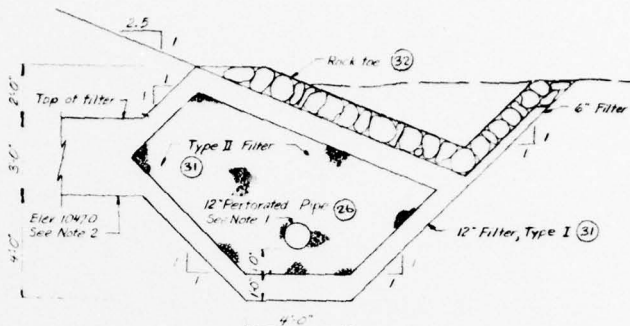
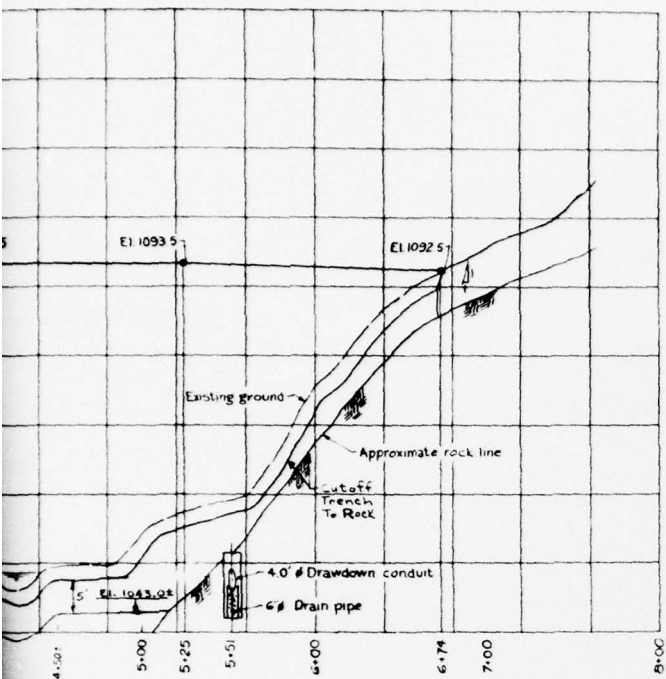

TYPICAL TOE DRAIN  
Scale 3/4" = 1'-0"

- Note:
1. Perforated Pipe shall be installed from Sta 3+30 to Sta 4+80.
  2. Filled Embankment is to Elev 1047.0 from Sta 3+90 to Sta 4+65.

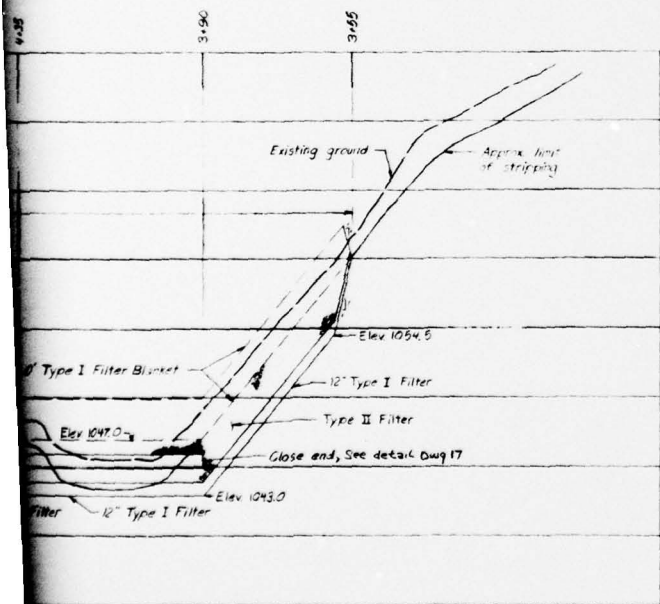

LOOKING UPSTREAM

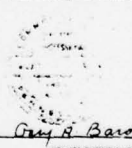
NO.	DATE	REVISION	APPR.
SUBMITTED			
<i>Gregory R. Barone</i> PROJECT ENGINEER			
APPROVED			
<i>William J. Schaefer</i> CHIEF, DIVISION OF WATER CONTROL STRUCTURES			
APPROVED			
<i>Robert J. ...</i> DIRECTOR, BUREAU OF DESIGN			
			
<i>Gregory R. Barone</i>			
COMMONWEALTH OF PENNSYLVANIA DEPARTMENT OF ENVIRONMENTAL RESOURCES OFFICE OF RESOURCE MANAGEMENT			
CONTRACT NO. RB-1-101.1			
STEPHEN FOSTER DAM MT. PISGAH STATE PARK			
DAM PROFILES			
DRAWN BY	DATE	DESIGNED BY	
CHECKED BY	SCALE		11 of 33
As shown			

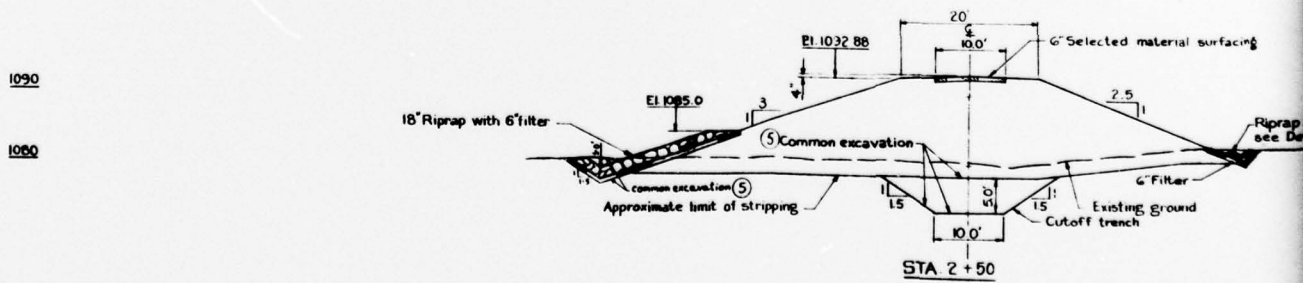
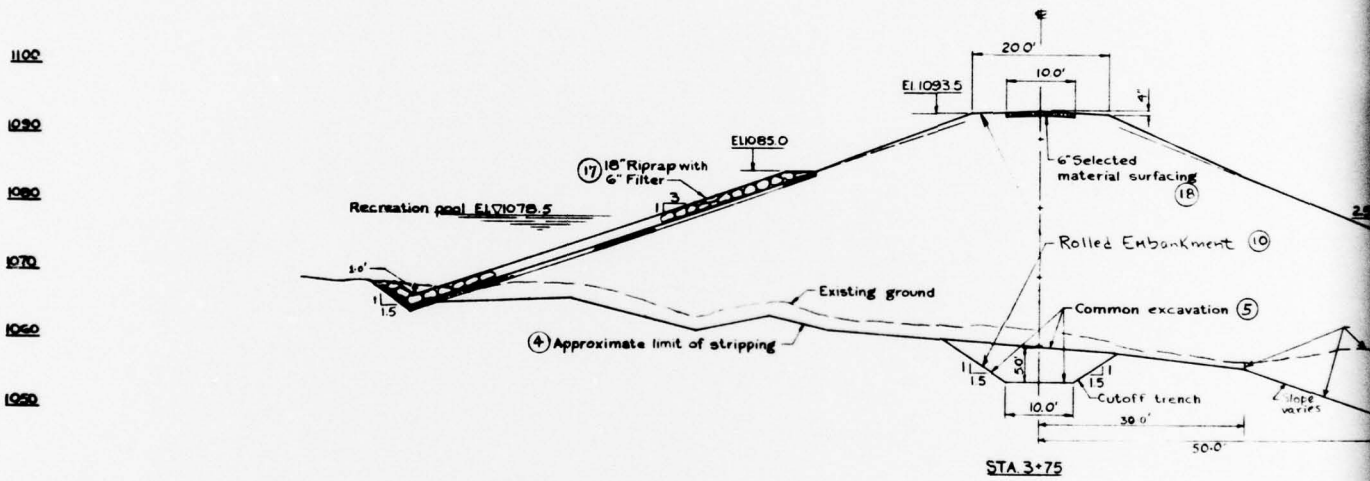
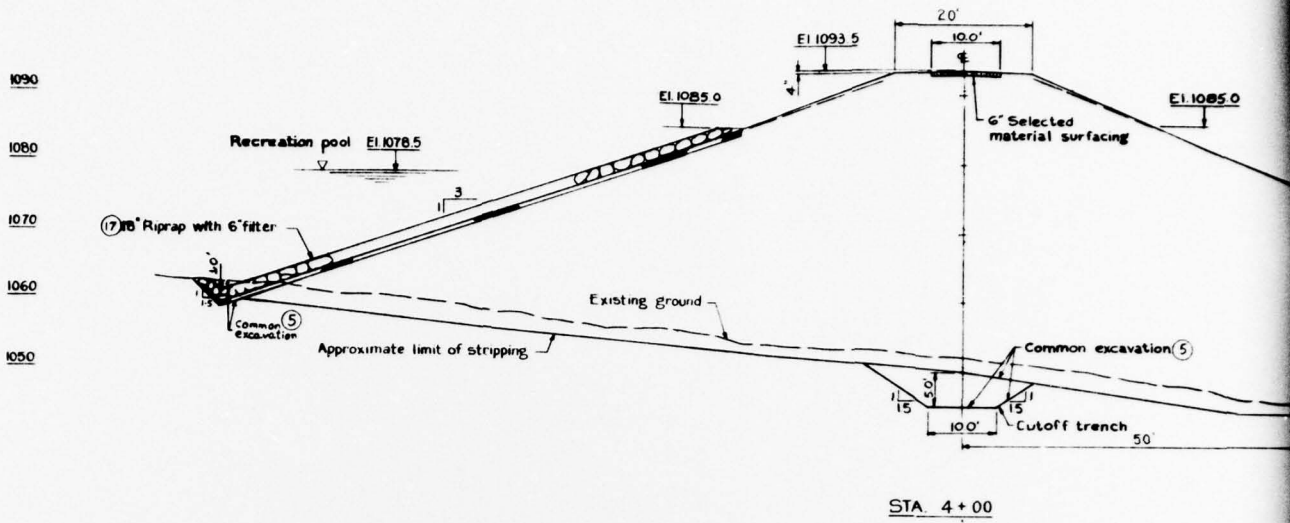



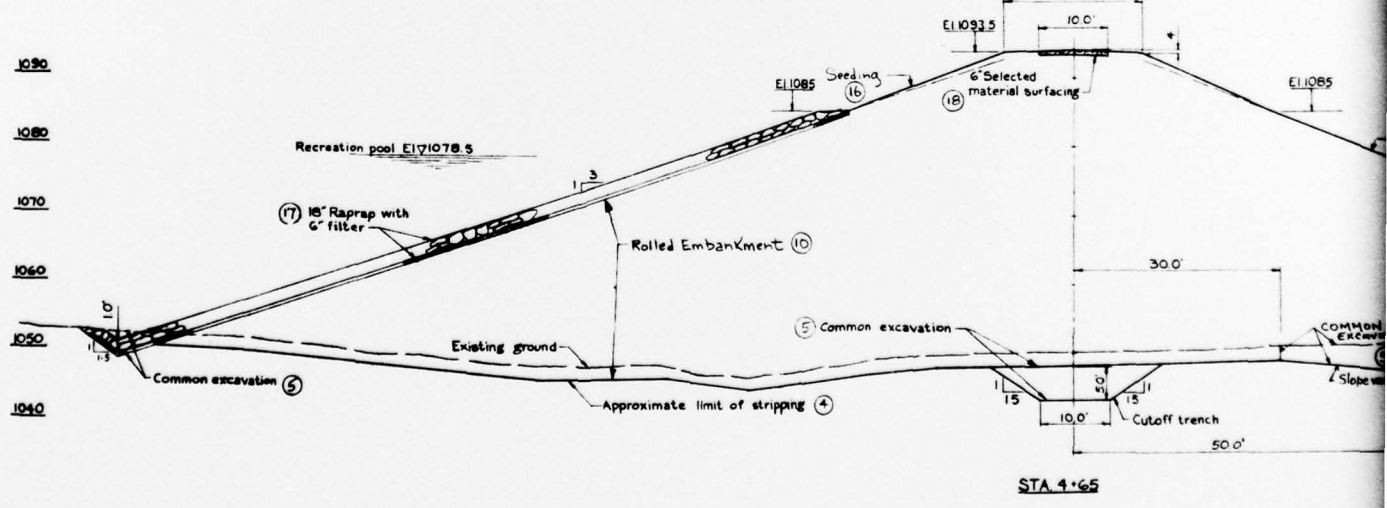
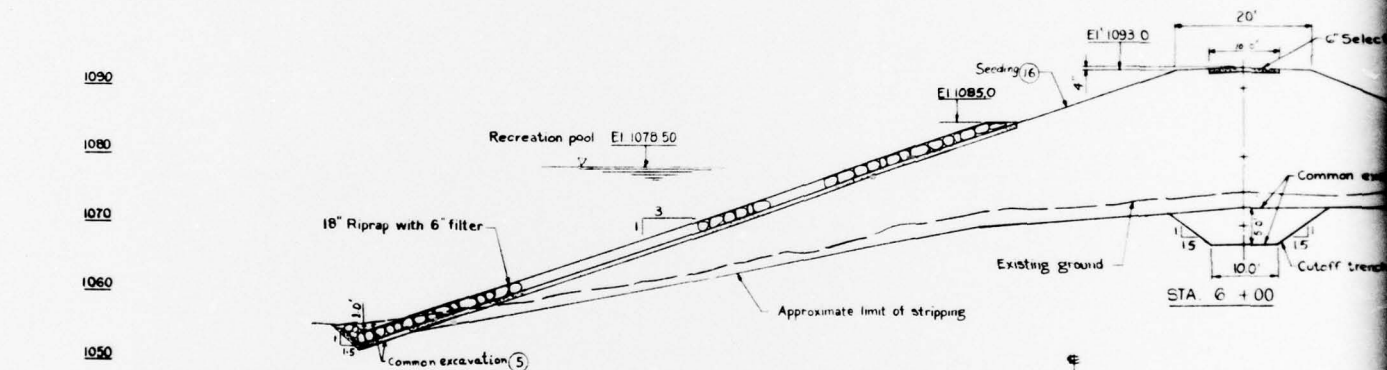
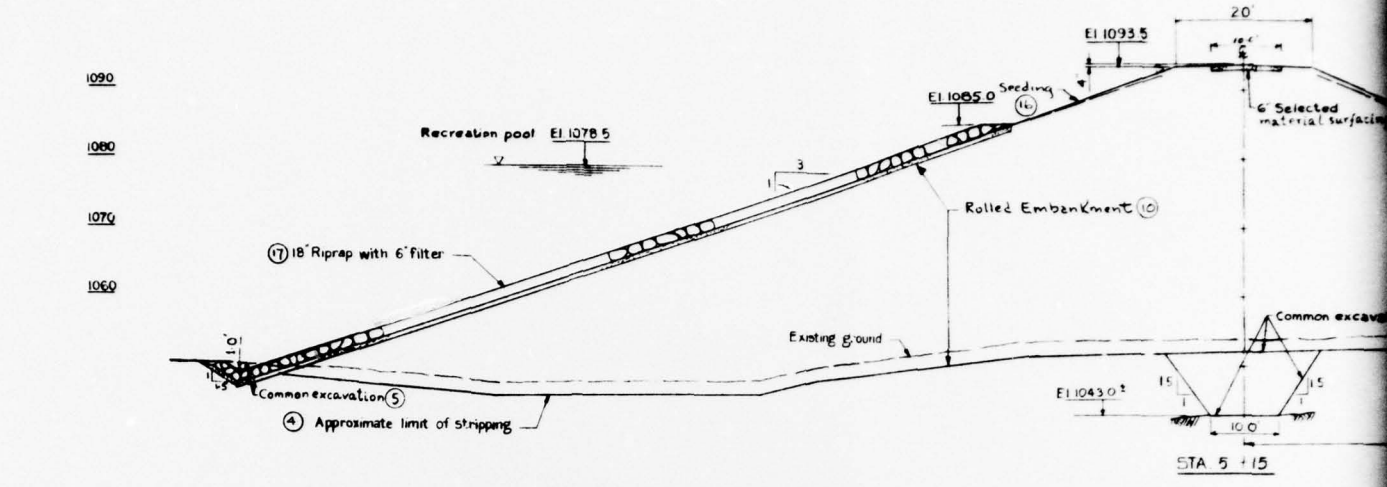

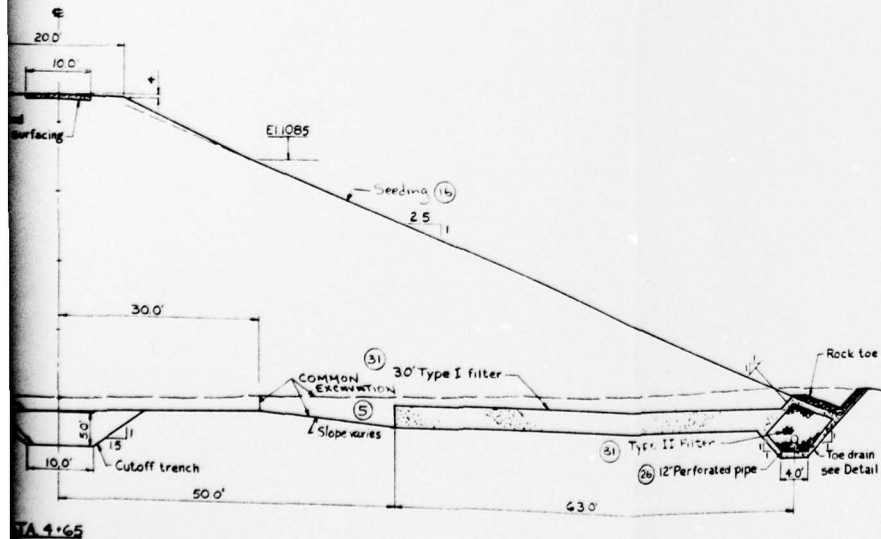
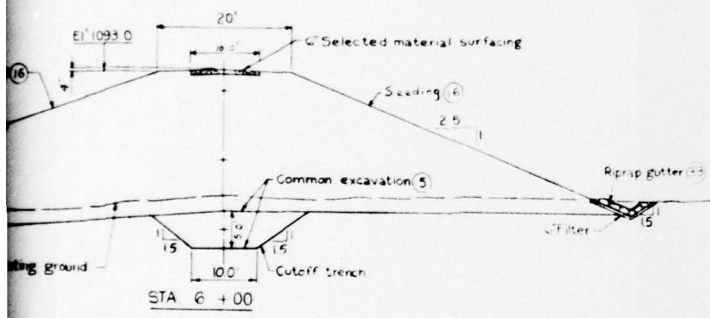
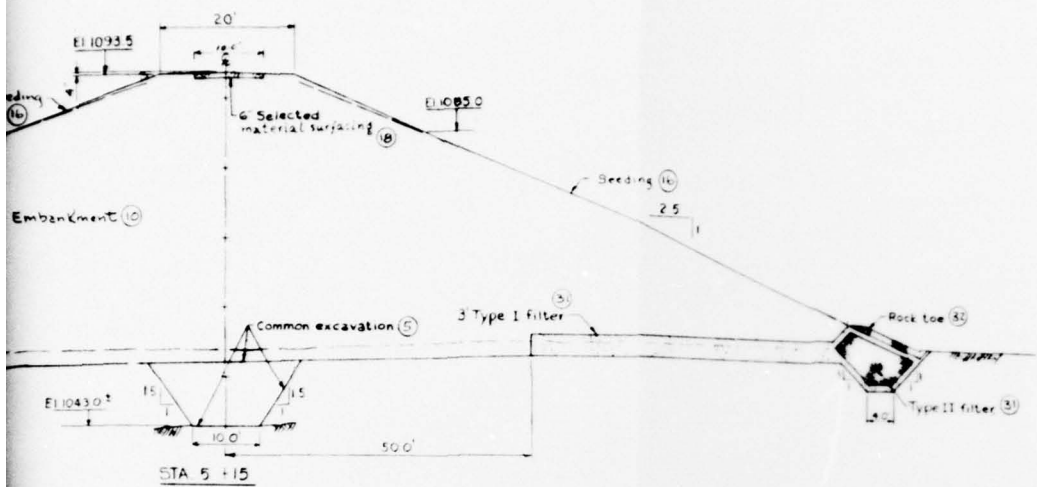

NO.	DATE	REVISION	APPR.
SUBMITTED			
PROJECT CO. ORIGINATOR			
APPROVED			
CHIEF, DIVISION OF WATER CONTROL STRUCTURES			
APPROVED			
DIRECTOR, BUREAU OF DESIGN			
COMMONWEALTH OF PENNSYLVANIA DEPARTMENT OF ENVIRONMENTAL RESOURCES OFFICE OF RESOURCES MANAGEMENT			
CONTRACT NO. R8-1-101.1			
STEPHEN FOSTER DAM MT. PISGAH STATE PARK			
DAM CROSS SECTIONS STA. 4+65 TO STA. 6+00			
DRAWN BY	DATE	DRAWING NO.	
CHECKED BY	SCALE	13 of 33	
	1 in = 10 ft		

L. ROBERT KIMBALL & ASSOCIATES  
 CONSULTING ENGINEERS & ARCHITECTS  
 FIGURE 5

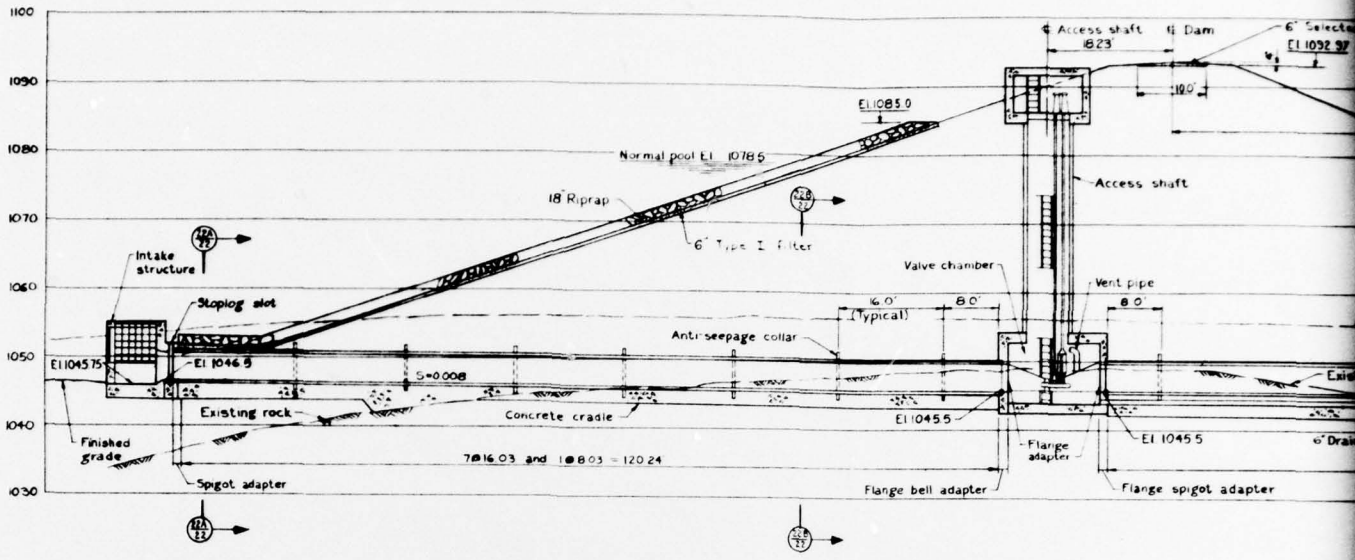

PROFILE ALONG A DRAWDOWN PIPE  
Scale: 1" = 10' ft.

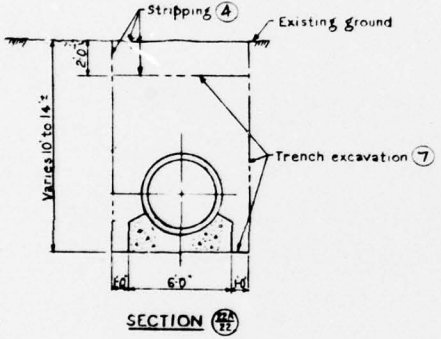

SECTION 77

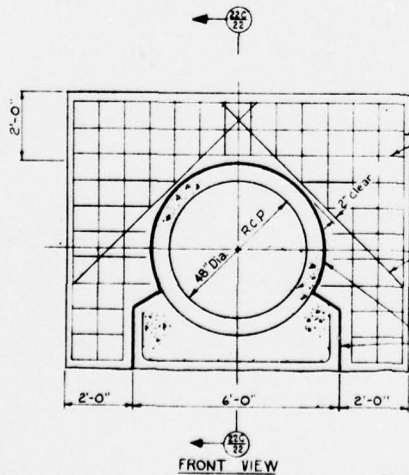
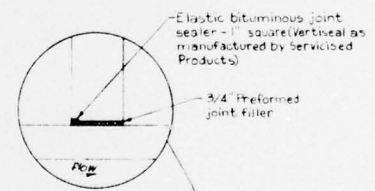

FRONT VIEW

ANTI-SEEPAGE COLLAR  
Scale: 1/2" = 1' ft.

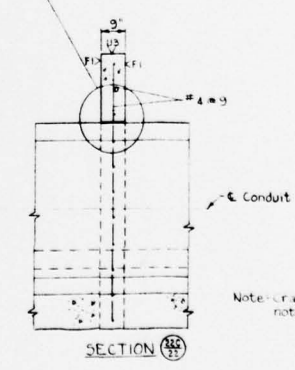

SECTION 78

Note: cradle steel note shown.

6" Asbestos cement drain pipe, downstream of control shaft.

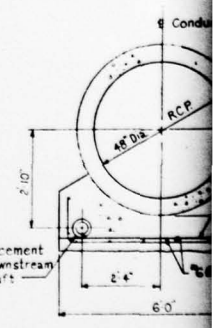

CRADLE DETAIL  
Scale: 1/2" = 1' ft.

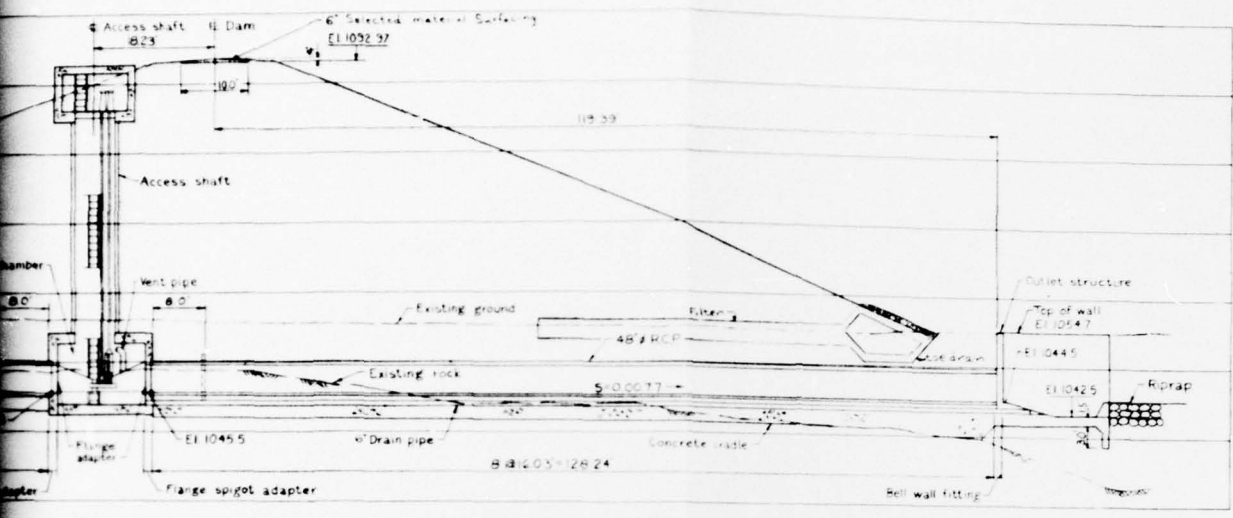

**NOTES:**  
 1. The distances given for the conduit assume an average creep of 0.3 ft per joint in laying pipe. Headwall locations may be adjusted slightly for actual creep.

**ALONG & DRAWDOWN PIPE**  
 Scale: 1 in = 10 ft

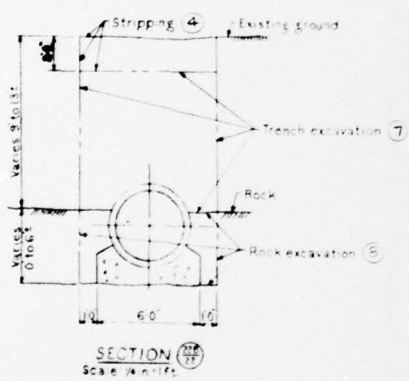

**SECTION 7-7**  
 Scale: 1/4 in = 1 ft

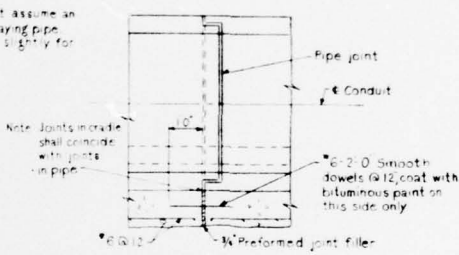

**CRADLE JOINT DETAIL**  
 Scale: 1 in = 1 ft

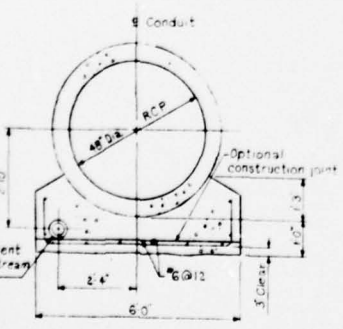

**CRADLE DETAIL**  
 Scale: 1/2 in = 1 ft

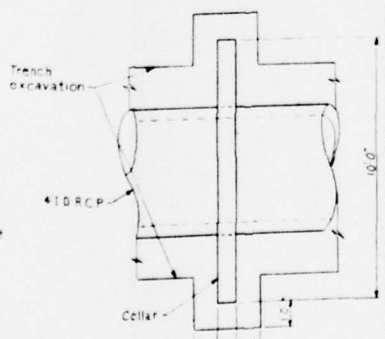

**TYPICAL PLAN**  
 (Looking at collar)  
 Scale: 3/4 in = 1 ft

NO	DATE	REVISION	APPR.
SUBMITTED BY: <i>Gray B. Basore</i>			
APPROVED BY: <i>William A. Shaw</i> CHIEF DIVISION OF WATER CONTROL STRUCTURES			
APPROVED BY: <i>Andrew Mag...</i> DIRECTOR, BUREAU OF DESIGN			
COMMONWEALTH OF PENNSYLVANIA DEPARTMENT OF ENVIRONMENTAL RESOURCES OFFICE OF RESOURCES MANAGEMENT			
CONTRACT NO. R8-I-1011  STEPHEN FOSTER DAM MT. PISGAH STATE PARK			
<b>DRAWDOWN STRUCTURE</b>			
DRAWN BY:	DATE:	DRAWING NO.	
CREATED BY:	SCALE:	As shown	22 of 33

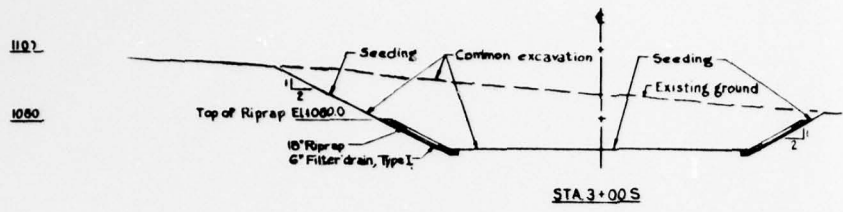

STA 3+00S

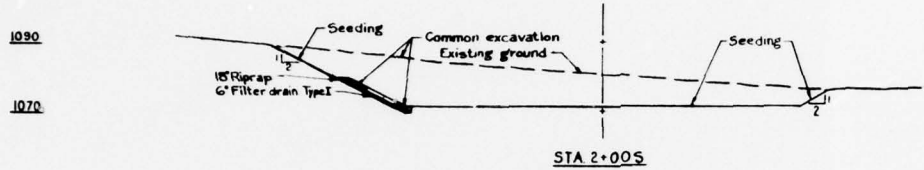

STA 2+00S

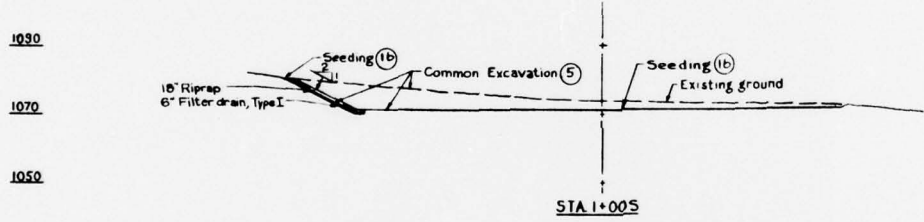

STA 1+00S

CROSS SECTIONS  
Scale 1 in = 20 ft

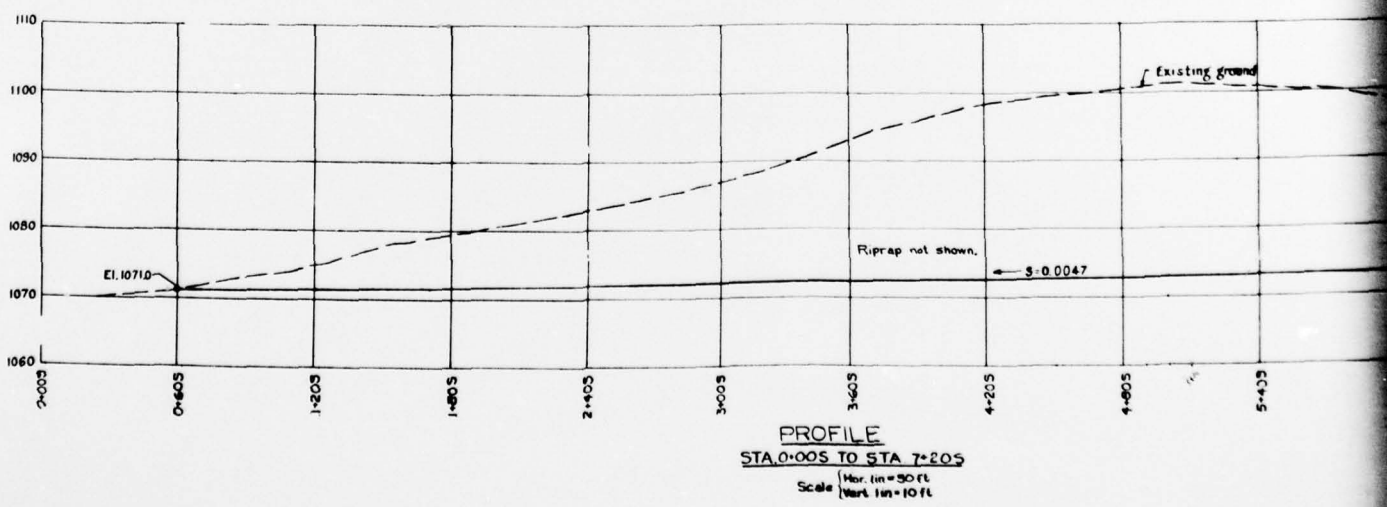

PROFILE  
STA 0+00S TO STA 7+20S  
Scale Hor. 1 in = 50 ft  
Vert. 1 in = 10 ft



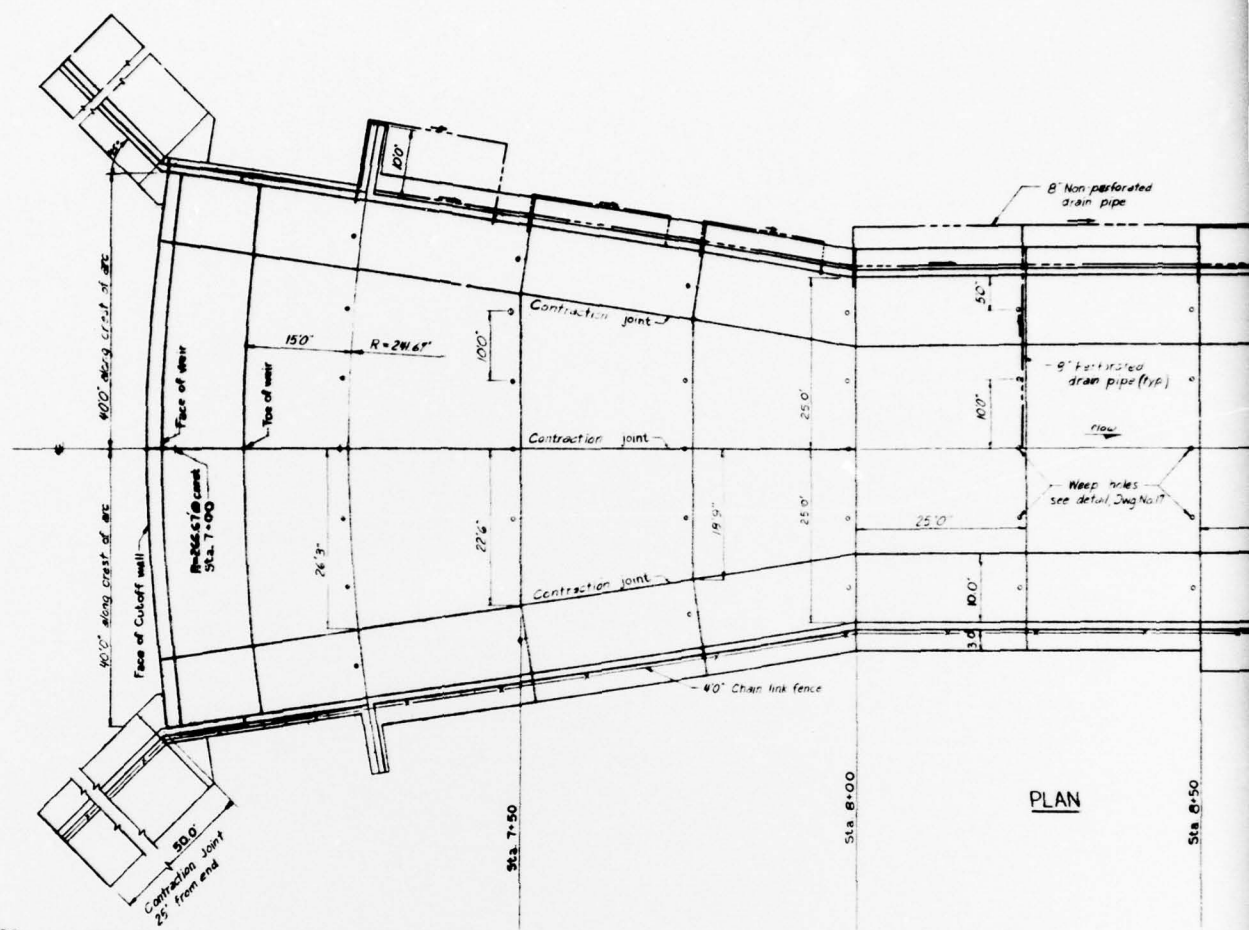

PLAN

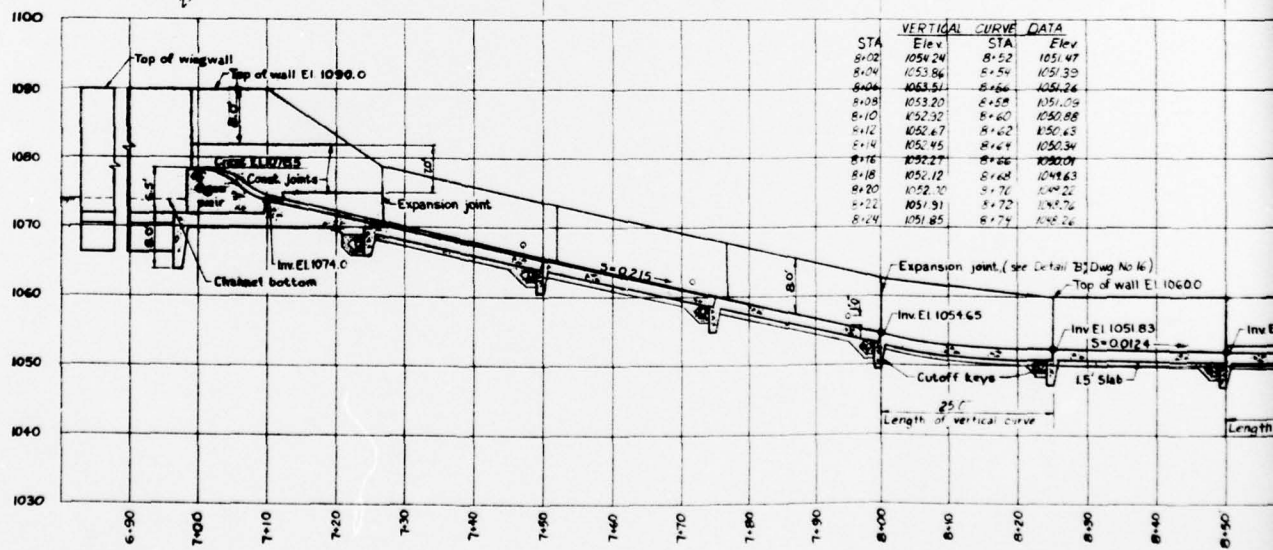

VERTICAL CURVE DATA			
STA	Elev	STA	Elev
8+02	1054.24	8+52	1051.47
8+04	1053.86	8+54	1051.39
8+06	1053.51	8+56	1051.26
8+08	1053.20	8+58	1051.09
8+10	1052.92	8+60	1050.88
8+12	1052.67	8+62	1050.63
8+14	1052.45	8+64	1050.34
8+16	1052.27	8+66	1050.01
8+18	1052.12	8+68	1049.63
8+20	1052.00	8+70	1049.22
8+22	1051.91	8+72	1048.78
8+24	1051.85	8+74	1048.32

PROFILE



### General Geology.

The Stephen Foster Dam lies within the Glaciated Low Plateaus Section of the Appalachian Plateaus Physiographic Province. This area is characterized by broad anticlines and synclines and little, if any, faulting. There are no faults in the vicinity of the dam.

The bedrock under Stephen Foster Dam consists of the Devonian aged Susquehanna Group. This is a complex unit of sandstones, siltstones, shales and conglomerates. Usually the following changes occur from the bottom to the top of the group; the sediment grain size increases, the average thickness of the beds increases, the shales become redder, and the percentage of silica increases. The bedding is usually well developed with thicknesses ranging from less than one to over fifteen feet. The joints are usually closely spaced in a well developed, regular pattern in the shales and siltstones. The shales weather rapidly, while the sandstones, siltstones and conglomerates are moderately resistant. This group can form a good foundation for heavy structures if it is excavated to solid material and the shales and siltstones are kept water free. The surface drainage is moderate to good, except in glaciated regions, such as this one, where it is poor. The interstitial porosity is low in the coarser rocks while the joint development allows a medium quantity of total effective porosity.



Geologic Map of Stephen Foster Dam Area

CENTRAL AND EASTERN PENNSYLVANIA



**Oswayo Formation**  
*Brownish and greenish gray, fine and medium grained sandstones with some shales and scattered calcareous lenses includes red shales which become more numerous eastward. Relation to type Chemung proved.*



**Catskill Formation**  
*Chiefly red to brownish shales and sandstones, in some gray and greenish sandstone, tuffaceous, named Elk Mountain, Honesdale, Shohola, and Delaware River in the east.*



**Marine beds**  
*Gray to olive brown shales, greenish, and sandstones including Chemung beds and Butport beds including Buckel, Briscoe, Havel, and Trimmers Rock. Top limestone at base.*



**Susquehanna Group**  
*Barbed line is "Chemung-Catskill" contact of Second Pennsylvania Survey. County reports, barbs on "Chemung" side of line.*

Scale: 1:250,000