

AD-A072 985

DAVID W TAYLOR NAVAL SHIP RESEARCH AND DEVELOPMENT CE--ETC F/G 7/4  
ULTRAFILTRATION OF ACTIVATED SLUDGE: A COMPARISON OF THREE MEMB--ETC(U)  
JUL 79 L R HARRIS  
DTNSRDC/SME-78/1

UNCLASSIFIED

NL

| OF |

404  
072985



END  
DATE  
FILMED  
9-79  
DDC

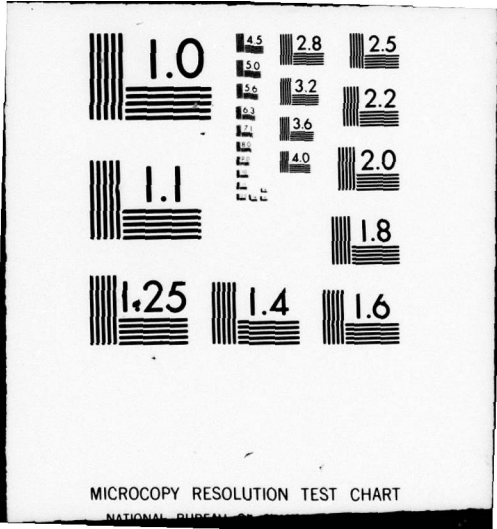

DTNSRDC/SME-78/1

**LEVEL** *12* *B.S.*

**DAVID W. TAYLOR NAVAL SHIP  
RESEARCH AND DEVELOPMENT CENTER**



Bethesda, Maryland 20084

**A 072985**

ULTRAFILTRATION OF ACTIVATED SLUDGE:  
A COMPARISON OF THREE MEMBRANE CONFIGURATIONS

by

L.R. Harris



APPROVED FOR PUBLIC RELEASE; DISTRIBUTION UNLIMITED

**DDC FILE COPY**

SHIP MATERIALS ENGINEERING DEPARTMENT  
RESEARCH AND DEVELOPMENT REPORT

July 1979

DTNSRDC/SME-78/1

ULTRAFILTRATION OF ACTIVATED SLUDGE:  
A COMPARISON OF THREE MEMBRANE CONFIGURATIONS

79 08 22 031

# MAJOR DTNSRDC ORGANIZATIONAL COMPONENTS

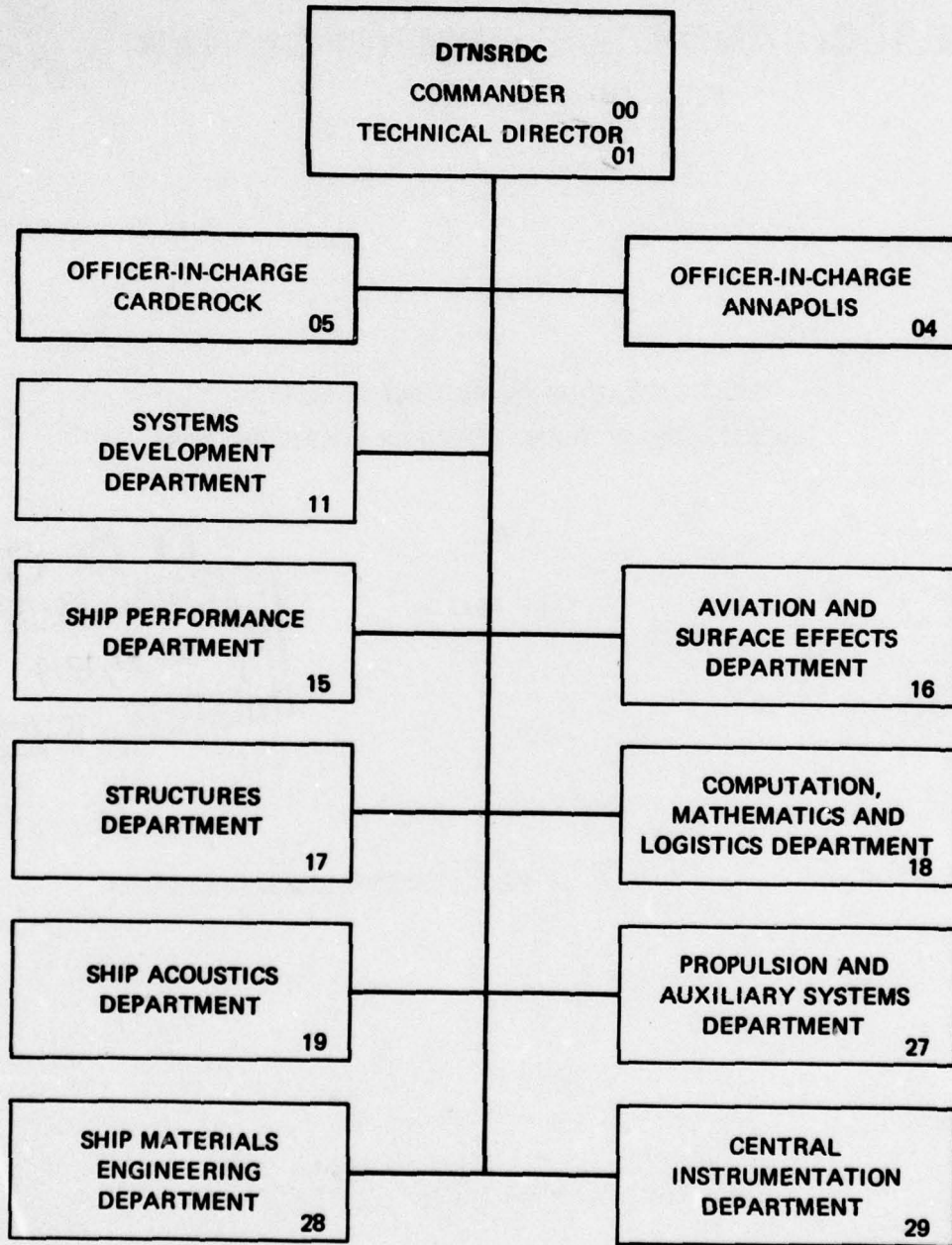

UNCLASSIFIED

SECURITY CLASSIFICATION OF THIS PAGE (When Data Entered)

REPORT DOCUMENTATION PAGE		READ INSTRUCTIONS BEFORE COMPLETING FORM	
1. REPORT NUMBER DTNSRDC/SME-78/1	2. GOVT ACCESSION NO.	3. RECIPIENT'S CATALOG NUMBER	
4. TITLE (and Subtitle) ULTRAFILTRATION OF ACTIVATED SLUDGE; A COMPARISON OF THREE MEMBRANE CONFIGURATIONS		5. TYPE OF REPORT & PERIOD COVERED Research & Development <i>repts</i>	
7. AUTHOR(s) L.R. Harris		6. CONTRACT OR GRANT NUMBER(s)	
9. PERFORMING ORGANIZATION NAME AND ADDRESS David W. Taylor Naval Ship R&D Center Bethesda, Maryland 20084		10. PROGRAM ELEMENT, PROJECT, TASK AREA & WORK UNIT NUMBERS Program Element 62765N Task Area ZF 65-572-003 Work Unit 1-2860-101	
11. CONTROLLING OFFICE NAME AND ADDRESS Naval Material Command (MAT 08T241) Support Technology Division Washington, D.C. 20362		12. REPORT DATE July 1979	
14. MONITORING AGENCY NAME & ADDRESS (if different from Controlling Office) F65572		13. NUMBER OF PAGES 33	
		15. SECURITY CLASS. (of this report) UNCLASSIFIED . . . . .	
		15a. DECLASSIFICATION/DOWNGRADING SCHEDULE	
16. DISTRIBUTION STATEMENT (of this Report) APPROVED FOR PUBLIC RELEASE; DISTRIBUTION UNLIMITED. ZF 65572-003			
17. DISTRIBUTION STATEMENT (of the abstract entered in Block 20, if different from Report) 36 p1			
18. SUPPLEMENTARY NOTES			
19. KEY WORDS (Continue on reverse side if necessary and identify by block number) Ultrafiltration Membrane Sewage Treatment Activated Sludge			
20. ABSTRACT (Continue on reverse side if necessary and identify by block number) Tubular, plate-and-frame, and hollow-fiber ultrafiltration membranes were evaluated using screened activated sewage to determine their flux performance, maintenance requirements, and rejection of fecal coliform bacteria and suspended solids. The membranes were evaluated concurrently. Both the tubular and hollow-fiber systems consistently satisfied the marine discharge requirements for fecal coliform bacteria and suspended solids. The (Continued on reverse side)			

*slf*

UNCLASSIFIED

SECURITY CLASSIFICATION OF THIS PAGE (When Data Entered)

(Block 20 continued)

hollow-fiber membrane showed signs of physical plugging toward the end of the test. Although the plate-and-frame membrane consistently satisfied the suspended solids requirement, it showed inconsistent rejection of fecal coliform bacteria.

No cleaning agents were used on the membranes during the evaluation. However, the hollow-fiber membrane required frequent reverse flushing with activated sludge to maintain an operable system. Depressurization of the membranes, either overnight or over the weekend, produced sufficient flux recovery that membrane cleaning was unnecessary. Performance of the plate-and-frame membrane during this investigation was compared to previous studies of that membrane under pressure and vacuum modes of operation. The pressure mode was determined to be more desirable.

The tubular system showed the best overall performance in terms of membrane flux, rejection, and operating costs. It was recommended that this system be evaluated in long-term tests with raw-aerated sewage to establish reliability and maintainability requirements.

Accession For	
NTIS GRA&I	
DDC TAB	
Unannounced	
Justification	
By	
Distribution/	
Availability Codes	
Dist	Avail and/or special
A	

UNCLASSIFIED

SECURITY CLASSIFICATION OF THIS PAGE (When Data Entered)

TABLE OF CONTENTS

	Page
LIST OF FIGURES. . . . .	iv
LIST OF TABLES . . . . .	iv
LIST OF ABBREVIATIONS. . . . .	v
ABSTRACT . . . . .	1
ADMINISTRATIVE INFORMATION . . . . .	1
INTRODUCTION . . . . .	1
OBJECTIVE. . . . .	3
EXPERIMENTAL . . . . .	3
DESCRIPTION OF MEMBRANE CONFIGURATIONS. . . . .	3
DESCRIPTION OF TEST LOOP. . . . .	5
METHODS . . . . .	5
RESULTS AND DISCUSSION . . . . .	6
EFFECT OF SUSPENDED SOLIDS. . . . .	8
FECAL COLIFORM BACTERIA REJECTION . . . . .	9
MEMBRANE CLEANING. . . . .	10
COMPARISON OF PRESSURE AND VACUUM PLATE-AND-FRAME UF SEWAGE TESTS. . . . .	12
ECONOMICS. . . . .	13
CONCLUSIONS AND FINDINGS . . . . .	15
ACKNOWLEDGMENT . . . . .	16
APPENDIX A - DAILY AVERAGE FLUX. . . . .	23
APPENDIX B - DAILY FLUX DECLINE RATES. . . . .	25
APPENDIX C - DAILY TOTAL SUSPENDED SOLIDS CONCENTRATION. . . . .	27
APPENDIX D - DAILY FECAL COLIFORM BACTERIA CONCENTRATION . . . . .	29
REFERENCES . . . . .	31

## LIST OF FIGURES

	Page
1 - Tubular Ultrafiltration Membrane. . . . .	17
2 - Hollow-Fiber Ultrafiltration Module . . . . .	18
3 - Plate-and-Frame Membrane Cartridge and Housing. . . . .	19
4 - Ultrafiltration Test Loop Schematic . . . . .	20
5 - Membrane Flux Curves. . . . .	21
6 - Plate-and-Frame Membrane Performance with Aerated Sewage and Activated Sludge . . . . .	22

## LIST OF TABLES

1 - Descriptive Characteristics of Membrane Configurations . . . . .	4
2 - Membrane Operating Limits. . . . .	4
3 - Membrane Operating Parameters. . . . .	4
4 - Average Daily Membrane Flux. . . . .	7
5 - Average Daily Flux Decline Rates . . . . .	7
6 - Concentration of Suspended Solids. . . . .	8
7 - Concentration of Fecal Coliform Bacteria . . . . .	9
8 - Water Flux after Membrane Cleaning . . . . .	11
9 - Operating Parameters for Two Pressure Operated Plate-and-Frame Membrane Tests with Sewage . . . . .	12
10 - Comparison of Membrane Operating Costs . . . . .	14

## LIST OF ABBREVIATIONS

Å	Angstrom unit equal to $1 \times 10^{-10}$ meters
BUF	Biological ultrafiltration
cm	Centimeter
ft <sup>2</sup>	Square foot
ft/sec	Foot per second
gal/day	Gallon per day
gal/ft <sup>2</sup> /day	Gallon per square foot per day
gal/min	Gallon per minute
Hg	Mercury
kPag	Kilopascal gage
ℓ	liter
ℓ/min	Liter per minute
m/day	Meter per day (reduced from $m^3/m^2/day$ )
m/sec	Meter per second
m <sup>2</sup>	Square meter
m <sup>3</sup> /day	Cubic meter per day
mg/ℓ	Milligram per liter
mil	One 1/1000th of an inch
mℓ	Milliliter
mm	Millimeter
psig	Pound per square inch gage
μm	Micrometer
UF	Ultrafiltration

## ABSTRACT

Tubular, plate-and-frame, and hollow-fiber ultrafiltration membranes were evaluated using screened activated sewage to determine their flux performance, maintenance requirements, and rejection of fecal coliform bacteria and suspended solids. The membranes were evaluated concurrently. Both the tubular and hollow-fiber systems consistently satisfied the marine discharge requirements for fecal coliform bacteria and suspended solids. The hollow-fiber membrane showed signs of physical plugging toward the end of the test. Although the plate-and-frame membrane consistently satisfied the suspended solids requirement, it showed inconsistent rejection of fecal coliform bacteria.

No cleaning agents were used on the membranes during the evaluation. However, the hollow-fiber membrane required frequent reverse flushing with activated sludge to maintain an operable system. Depressurization of the membranes, either overnight or over the weekend, produced sufficient flux recovery that membrane cleaning was unnecessary. Performance of the plate-and-frame membrane during this investigation was compared to previous studies of that membrane under pressure and vacuum modes of operation. The pressure mode was determined to be more desirable.

The tubular system showed the best overall performance in terms of membrane flux, rejection, and operating costs. It was recommended that this system be evaluated in long-term tests with raw-aerated sewage to establish reliability and maintainability requirements.

## ADMINISTRATIVE INFORMATION

This work was accomplished under Program Element 62765N, Task Area ZF 65-572-003. Work Unit 1-2860-101.

## INTRODUCTION

The development of a solid-liquid separation system which can remove suspended solids and bacteria from sewage in a single operation, concentrate the wastes, and discharge an effluent capable of meeting marine

discharge regulations<sup>1\*</sup> is one waste treatment concept under consideration by operators of marine vessels. Many of the systems that have been previously investigated for shipboard application have had to be rejected because of failure to meet one or more of the following requirements: space, weight, ease of installation, cost, maintainability or reliability. A maturing technology, which is finding increased use in wastewater treatment and which appears to satisfy the above requirements, is a pressure-driven-membrane process known as ultrafiltration (UF).

The UF process:

1. offers the ability to separate macromolecules, colloids, bacteria, and suspended solids from a wastewater stream without requiring a phase change.
2. operates at low pressure, generally 100 psig (700 kPag).<sup>\*\*</sup>
3. requires only one prime moving device - a circulation pump for maintaining pressure and high flow rates along the membrane surface.

While UF is a potentially attractive process, it does have major limitations, including:

1. fouling of membranes which results in a decreased effluent rate.
2. frequency of membrane cleaning due to fouling has not been established for various wastewater types.
3. operating costs, which may be higher than conventional sewage treatment techniques depending on the size of the UF system.

In general, UF involves circulating a liquid (wastewater) over a membrane surface at low pressure, such that two streams are produced, a permeate and a concentrate. The permeate is the stream that is essentially free of suspended solids and bacteria, whereas the concentrate consists of the original wastewater with a higher concentration of suspended solids. It is possible for UF to concentrate the wastewater to more than 100-fold its initial concentration. Thus, in addition to separation, UF is also a concentration process.

---

\*A list of references is given on page 31.

\*\*A list of abbreviations is given on page v.

The effectiveness of processing raw sewage by UF in meeting marine discharge regulations for fecal coliform bacteria and suspended solids has been recently reported.<sup>2,3</sup> UF's ability to satisfy these regulations has also been recently demonstrated in a U.S. Army-funded study.<sup>4</sup> However, over extended periods of shutdown, e.g., weekends, this investigation showed that bacteria contaminated permeate lines by some yet unknown mechanism, and consequently, disinfection was required. In an earlier Navy-funded study,<sup>5</sup> a biological oxidation/plate-and-frame UF system was evaluated while processing raw sewage. Process feasibility was demonstrated for suspended solids removal and, in most cases, for coliform bacteria removal. The permeate of this system was obtained by vacuum extraction from the membranes.

#### OBJECTIVE

The objectives of this study were 3-fold: (1) to further evaluate and compare the performance of three membrane configurations - hollow-fiber, plate-and-frame, and tubular, which were shown in an earlier study<sup>2</sup> to be capable of processing sewage, (2) to evaluate and compare the three membrane configurations' performance with sewage treated in a biological oxidation system (activated sludge), and (3) to determine whether the membranes could process activated sludge for extended periods without requiring membrane cleaning. Operation of a marine sewage treatment system without the need for frequent cleaning enhances its potential for shipboard application by reducing maintenance and increasing reliability.

#### EXPERIMENTAL

##### DESCRIPTION OF MEMBRANE CONFIGURATIONS

Three noncellulosic UF membrane configurations were evaluated. A summary of their descriptive characteristics is shown in Table 1.

Table 2 summarizes each membrane's operating limits. Photographs of the tubular, hollow-fiber, and plate-and-frame membrane used in this investigation are shown in Figures 1, 2, and 3, respectively. Operating parameters used to evaluate each membrane are shown in Table 3. These were based on manufacturers recommendations and previous experience with the membranes.

TABLE 1 - DESCRIPTIVE CHARACTERISTICS  
OF MEMBRANE CONFIGURATIONS

Membrane Configuration	Membrane Surface Area		Molecular Weight Cutoff	Apparent Pore Diameter, $\text{\AA}$	Nominal Channel Height	
	ft <sup>2</sup>	m <sup>2</sup>			mils	mm
Plate-and-Frame	2.0	0.2	18,000	30-50	125	3.1
Hollow-Fiber	15.0	1.4	50,000	50	45	1.1

TABLE 2 - MEMBRANE OPERATING LIMITS

Membrane Configuration	Maximum Temperature		Maximum Pressure		pH Range
	$^{\circ}\text{F}$	$^{\circ}\text{C}$	psig	kPag	
Tubular	180	82	60	420	2.0-13.0
Plate-and-Frame	122	50	75	525	2.5-10.5
Hollow-Fiber	122	50	25	175	1.5-13.0

TABLE 3 - MEMBRANE OPERATING PARAMETERS\*

Membrane Configuration	Average Operating Pressure		Circulation Rate	
	psig	kPag	gal/min	l/min
Tubular	32	224	28	106
Plate-and-Frame	22	154	25	95
Hollow-Fiber	10	70	15	57

\*Temperature held constant at 80 $^{\circ}\text{F}$  (27 $^{\circ}\text{C}$ ).

## DESCRIPTION OF TEST LOOP

Figure 4 shows the flow schematic of the test loop used to evaluate the three membrane configurations. Raw sewage obtained from an office complex at the Center entered an activated sludge tank. This wastewater was typical of shipboard sewage having a suspended solids concentration of approximately 0.1%. The activated sludge tank was part of a biological oxidation-UF(BUF) system, which was designed and operated in a manner similar to that described by Bailey, et al.<sup>5</sup> A rotary screen containing 0.02-cm diameter conical holes (9% open area) prescreened the sewage. Screened wastewater was transferred from the rotary screen to a 50-gal. (189-ℓ) feed tank. Centrifugal pumps pressurized the wastewater feed on the individual test loops and circulated the wastes across the membrane surfaces. The hollow-fiber and plate-and-frame membranes could be reverse flushed with activated sludge or freshwater if necessary. Based on previous experience with the tubular configuration, this membrane would not require reverse flushing. Cooling coils were used to maintain a constant temperature of 80°F (27°C) in the test loops. The feed tank supplied the three membrane modules with screened activated sludge.

## METHODS

An evaluation was undertaken to compare the performance of the plate-and-frame membrane's processing of screened activated sludge with the hollow-fiber and tubular membranes. Performance was also compared with previously reported results of the plate-and-frame membrane processing activated sludge/sewage in both the vacuum and pressure modes of operation.

Initially, activated sludge was added to the feed tank at a rate equivalent to the permeate discharged collectively by the three modules. At approximately 65 hours of testing, the feed tank contents were processed in a batch pump down mode; i.e., the contents were processed until the tank level reached 10 gal. (38 ℓ) for a 5-fold increase in concentration. Forty gal. (152 ℓ) of activated sludge then was added to the concentrated wastes in the feed tank. This was done to determine if the membranes could process increased activated sludge concentrations without loss of performance.

The concentrates of each membrane were returned to the feed tank. Thus, a buildup of suspended solids occurred in the feed tank more rapidly

than if any one membrane was evaluated separately. This concentrated waste was mixed with the filtrate of the rotary screen after each day's test. This was done to minimize odors in the feed tank and to recover the concentrated solids. No cleaning procedure (flushing with emzyne-detergent or hypochlorite solution) was employed on the membranes during the investigation.

Temperature within the individual circulation loops, pressure drop, flow rates across each membrane's surface, and permeate rates were recorded. Operating conditions were selected based on previous Center experience with membranes and manufacturers recommendations. Samples from the effluent of each module as well as from the feed tank were analyzed for suspended solids and fecal coliform bacteria. All analyses were performed according to "Standard Methods."<sup>6</sup>

#### RESULTS AND DISCUSSION

A chronology of flux data for the three membrane configurations is shown in Figure 5. The abrupt increases in flux (spikes) are probably due to depressurization and polymer relaxation of the membranes because the test loop was shut down each evening and over the weekends.

Figure 5 shows a rise in flux for the tubular membrane between 30 and 60 hours. The hollow-fiber and the plate-and-frame membranes did not behave in this fashion. No explanation can be offered for this behavior. A new plate-and-frame membrane was installed after approximately 22 hours of operation because the permeate consistently showed fecal coliform bacteria in excess of the discharge regulations. However, the new membrane's permeate indicated similar passage of bacteria (see the section of this report on fecal coliform bacteria rejection.)

Table 4 shows the average daily flux (22-day test) for each membrane configuration. Average flux for each day is shown in Appendix A. The tubular membrane's average flux was more than 2.5-fold greater than the plate-and-frame membrane and more than 3-fold greater than the hollow-fiber membrane. Although the hollow-fiber shows a relatively constant flux, it was necessary to reverse flush with activated sludge once every 30 minutes to continue the test. The rotary screen could not protect the hollow fibers from plugging with fibrous material at the leading edge of the module.

TABLE 4 - AVERAGE DAILY MEMBRANE FLUX  
(22-day test)

Membrane Configuration	Average Flux		Standard Deviation	
	gal/ft <sup>2</sup> /day	m/day*	gal/ft <sup>2</sup> /day	m/day
Tubular	46	1.8	10.6	0.4
Plate-and-Frame	20	0.8	5.6	0.2
Hollow-Fiber	15	0.6	4.3	0.2

\*From m<sup>3</sup>/m<sup>2</sup>/day.

Table 5 summarizes the average daily flux decline rates (slope of flux versus time curve) of the membranes. The average rates were obtained using Figure 5 and using only the data obtained after 1 hour of operation. Appendix B shows the daily rates. After the large initial flux decline for each membrane on the first day of testing, the rates appear to level off for all membranes. This is most apparent over the last 12 days of testing. Average rates of the plate-and-frame membrane were approximately 2-fold greater than the tubular membrane over this period. This indicates the plate-and-frame membrane is more susceptible to fouling under the conditions employed. The hollow-fiber showed the largest average rate. This was primarily due to the membrane plugging with concentrated sludge, rather than fouling on the membrane surface. Because this membrane required reverse flushing with activated sludge every 15-30 minutes to maintain its operability, no trend of the daily rate was observed. These frequent flushings prevented the membrane from establishing an equilibrium flux.

TABLE 5 - AVERAGE DAILY FLUX DECLINE RATES\*

Days of Testing	Membrane Configuration		
	Tubular	Plate-and-Frame	Hollow-Fiber
22	-0.09	-0.14	-0.15
Last 12	-0.07	-0.12	-0.15

\*gal/ft<sup>2</sup>/day<sup>2</sup>.

## EFFECT OF SUSPENDED SOLIDS

Figure 5 also shows the effect of increased suspended solids. None of the membranes showed any significant flux decline over the first 60 hours. The tubular system shows an unexplainable rise in flux between 30 and 60 hours. Once the batch concentration of the feed tank began (approximately 60 hours into the test), a flux decline was noted for the tubular and hollow-fiber membranes. The tubular membrane showed a small flux decline for the remaining 100 hours of testing.

The membranes were always able to reject suspended solids to a level less than the required 150 mg/l. Maximum suspended solids measured in the permeates were 34, 29, and 24 mg/l for the tubular, plate-and-frame, and hollow-fiber membranes, respectively. Table 6 summarizes the membranes rejection of suspended solids. Appendix C lists the daily concentration of suspended solids measured in the feed tank and in the permeates. Suspended solids in the feed tank increased over the 160 hours of testing. Solids accumulated significantly when the batch concentration began. Increased solids concentration affected the hollow-fiber membrane severely. The increased solids loading resulted in a decrease in the circulation rate, an increase in the pressure drop, and consequently, a decline in the flux. Reverse flushing with activated sludge was required every 15-30 minutes to minimize sludge compaction within the fibers, or a buildup of sludge at the leading edge of the modules. This module is transparent and it was easy to note that many fibers became noticeably darkened due to the compacted solids. The tubular and plate-and-frame systems were not similarly affected by the increased solids concentration.

TABLE 6 - CONCENTRATION OF SUSPENDED SOLIDS

Membrane Configuration	Feed Tank		Permeate		Discharge Requirement
	Average	Range	Average	Range	
Tubular			14	0-29	
Plate-and-Frame	3300	340-6700	8	0-24	<150
Hollow-Fiber			9	0-34	

Note: All figures in mg/l.

## FECAL COLIFORM BACTERIA REJECTION

Tubular and hollow-fiber membranes rejected fecal coliform bacteria, i.e., the permeates always contained  $<10/100$  ml. The plate-and-frame membrane was inconsistent. The concentration of fecal coliform bacteria in the feed and permeates is shown in Table 7. Appendix D lists the daily concentration of fecal coliform bacteria measured in the feed tank and the permeates of the three membranes. It is worth noting that although all membranes satisfied the discharge requirement (based on average fecal coliform bacteria data), the plate-and-frame membrane did not satisfy these requirements until the fecal coliform bacteria population in the feed tank decreased to  $10^5/100$  ml or less.

TABLE 7 - CONCENTRATION OF FECAL COLIFORM BACTERIA

Membrane Configuration	Feed Tank		Permeate		Discharge Requirement
	Average	Range	Average	Range	
Tubular			10	-	<u><math>\leq 200</math></u>
Plate-and-Frame	$4.7 \times 10^6$	$5 \times 10^4 - 2.1 \times 10^7$	155	$10 - 10^3$	
Hollow-Fiber			10	-	

Note: All figures in number of colonies/100 ml.

A new plate-and-frame membrane cartridge was placed into the test loop after 21 hours. The original membrane consistently allowed the presence of fecal coliform bacteria in the permeate in excess of the discharge requirement. This was thought to be due to a leak in the membrane or cartridge seals. However, the permeate continued to show fecal coliform bacteria in excess of the requirements when the new membrane cartridge was placed in the test loop.

A problem developed at approximately 70 hours into the test. The raw sewage which supplied input to the activated sludge system was contaminated with a chlorine based cleaning compound. Residual chlorine values up to 0.5 mg/l were measured. Fecal coliform bacteria in the feed tank dropped to  $<10^5$  colonies/100 ml. The residual chlorine persisted until the final

days of the test, as evidenced by the low fecal coliform concentration in the feed tank (see Appendix D). It is noted that when the residual chlorine was present, all permeates had fecal coliform bacteria concentrations of <10/100 ml. This was the only time that the plate-and-frame membrane showed good rejection. Passing of bacteria by the plate-and-frame membrane has been reported previously.<sup>5,7</sup> Because UF membranes have pore sizes in the Angstrom unit range, bacteria should not pass through a UF membrane. However, a recent study<sup>8</sup> showed the effectiveness of both UF and reverse osmosis membranes in removing bacteria from water. The authors concluded that, because of imperfections in the membrane polymer, bacteria can pass through the membrane and accumulate on the permeate side. Bacteria would not have had time to accumulate because the three modules used in this investigation had small hold-up volumes. Neither the tubular nor the hollow-fiber membranes allowed bacteria in their permeate. Consequently, it may be concluded that there is an inherent design problem with the plate-and-frame membrane, which allows bacteria to pass from the feed to the permeate, especially over a high bacteria concentration gradient.

#### MEMBRANE CLEANING

No attempt was made to clean the three membrane configurations. During the first 10 days of the test, the residual concentrate in the feed tank was transferred to the rotary screen effluent each evening prior to shutdown. The feed tank then was filled with approximately 10 gal. (38 l) of freshwater. This water was used to flush the membranes for 15 seconds.

The membranes were not flushed in this manner during 12 days of the test. Over that period, the residual concentrate was transferred to the rotary screen effluent, and the activated sludge in the test loop remained in contact with the membranes. The downtime varied from overnight to over the weekend. The membranes were depressurized during this period. Figure 5 shows that upon performing each daily test, the membrane fluxes increase to a value greater than the flux recorded prior to shutdown. This increase in flux is due possibly to membrane depressurization causing intrinsic membrane property changes.

On the first day of testing, the hollow-fiber module showed an increase in pressure drop and a decline in circulation rate soon after

start-up. The module was inspected and it was found that its leading edge had become plugged with screened concentrated activated sludge. The 0.2-mm conical holes of the rotary screen were unable to protect the 0.045-mil (1.1-mm) hollow-fibers from concentrated solids and fibrous material. If the module was reverse flushed with activated sludged for 30 seconds every 15-30 minutes, the evaluation of the hollow fiber could proceed without the need of chemical or physical cleaning. All membranes were cleaned following the completion of the 165-hour test. This cleaning was done to establish whether the membrane's initial water flux could be recovered. A 0.001% (10 mg/l) hypochlorite solution was prepared, added to the feed tank, heated to 110°F (43°C), and circulated through the membranes for 30 minutes at low pressure. Table 8 shows the flux recovered after cleaning in comparison to the initial water flux. No additional cleaning operations were performed.

TABLE 8 - WATER FLUX AFTER  
MEMBRANE CLEANING

Membrane Configuration	Initial Water Flux		Water Flux After Cleaning		Recovery %
	gal/ft <sup>2</sup> /day	m/day	gal/ft <sup>2</sup> /day	m/day	
Tubular	167	6.7	143	5.7	86
Plate-and-Frame	107	4.3	53	2.1	49
Hollow-Fiber	135	5.4	60	2.4	44

Only the tubular membrane shows an appreciable recovery of the initial water flux after cleaning. The low recovery of the hollow-fiber membrane is probably due to a buildup of concentrated activated sludge which plugged the fibers. Darkened slugs of solids were noticeable through the transparent casing even after cleaning. The low flux recovery for the plate-and-frame is consistent with the results of a previously reported study.<sup>7</sup>

**COMPARISON OF PRESSURE AND VACUUM  
PLATE-AND-FRAME UF SEWAGE TESTS**

Presented below is a discussion comparing sewage processing by the plate-and-frame membrane of this investigation with previously reported studies.<sup>2,5,9</sup> Fluxes of the plate-and-frame system with screened activated sludge are shown in Figure 6 and compared with those of processing screened-aerated-macerated sewage.<sup>2</sup> In the latter test several cleaning operations were employed, as indicated by the upward arrows in Figure 6. No cleaning was used in the former test. The operating parameters used and average fluxes determined for these tests are shown in Table 9. It is noted that a coarser screen was employed in the activated sludge test. The 3-fold increase in average flux with activated sludge was obtained without membrane cleaning. Weissman, et al,<sup>7</sup> showed comparable flux performance during the early phases of a long term test with screened activated sludge using operating pressures of 16-22 psig (112-154 kPag), linear velocities of 4-4.5 ft/sec (1.2-1.3 m/sec) at ambient temperatures. They reported fluxes of better than 8 gal/ft<sup>2</sup>/day (0.3 m/day) over a 6-month period.

**TABLE 9 - OPERATING PARAMETERS FOR TWO PRESSURE OPERATED  
PLATE-AND-FRAME MEMBRANE TESTS WITH SEWAGE\***

Type of Sewage Used	Screen Size	Average Operating Pressure		Linear Velocity		Circulating Flow Rate		Average Flux	
	µm	psig	kPag	ft/sec	m/sec	gpm	lpm	gal/ft <sup>2</sup> /day	m/day
Screened Activated Sludge	200	22	154	3.3	1.0	25	95	20.0	0.8
Aerated Macerated Sewage	105	30	150	6.0	1.8	45	170	6.5	0.3

\*Both tests conducted at 80°F (27°C).

In the activated sludge-ultrafiltration process discussed above, pressurizing the feed provided the necessary driving force to produce the concentrate and permeate streams. Vacuum can also be used to provide the necessary transmembrane pressure to produce the two streams. Operation of

such a system has been described by Bailey, et al.<sup>5</sup> The advantages of a vacuum extraction system include: (1) the elimination of pressure vessel housings which contain the membrane cartridge and (2) the treatment of wastewater on demand by having a surge capacitance.

The vacuum procedure has application in the low-pressure range, 1-10 psig (7-70 kPag) where flux is generally highly dependent on pressure. A constant flux is maintained by increasing the vacuum as the membrane fouls. Increased vacuum extraction also is required if adequate recirculation flow rates, feed concentrations, and temperatures are not maintained. Cleaning is required once the maximum vacuum is reached (29.9-in. Hg (760-mm Hg)). In the study cited above, a laboratory membrane system was designed to provide an average flux of 2 gal/ft<sup>2</sup>/day (0.08 m/day) with a surge capacity to 5 gal/ft<sup>2</sup>/day (0.2 m/day). A prototype system evaluated at this Center was designed for operation at a normal flux level of 4 gal/ft<sup>2</sup>/day (0.2 m/day) with a surge rate of 8 gal/ft<sup>2</sup>/day (0.3 m/day). In both the laboratory and prototype tests, fecal coliform bacteria counts were consistently greater than the required 240/100 ml (previous standard) or 200/100 ml (1981 regulation). The presence of the bacteria was believed to be due to permeate line contamination or an inherent design problem in the membrane cartridge. Although these tests were conducted under vacuum, results also show bacteria contamination of the permeate. Disinfection could be easily performed.

#### ECONOMICS

It would be premature to design a full-scale system for processing sewage based on the limited data obtained in this investigation. Additional testing consisting of longer term runs is required. However, the study provides an indication of the anticipated operating expenses that may be incurred. Generally, the major operating costs of any UF system are for circulating pump power consumption, membrane replacement, and cleaning.

In comparing the three membrane configurations of this investigation, only costs for power consumption and membranes are considered. These figures are shown in Table 10 and are based on the average and lowest fluxes obtained in this investigation. Initial and replacement membrane

costs are shown in the table. Because the tubular membrane can be stripped from its porous tubular support and recast with a raw membrane, the replacement cost is approximately 50% of the initial cost. The hollow-fiber and plate-and-frame membrane cartridges must be discarded.

TABLE 10 - COMPARISON OF MEMBRANE OPERATING COSTS\*

Membrane Configuration	Average Flux		Surface Area		Electrical Costs \$/day	Membrane Cost	
	gal/ft <sup>2</sup> /day	m/day	ft <sup>2</sup>	m <sup>2</sup>		Initial \$	Replacement \$
<u>Based on Average Flux</u>							
Tubular	46	1.8	22	2.0	1.72	2400	1100
Plate-and-Frame	20	0.8	50 <sup>^</sup>	4.6	1.43	2500	2500
Hollow-Fiber	15	0.6	75	7.0	1.07	1500	1500
<u>Based on Lowest Flux</u>							
Tubular	29	1.2	34	3.2	2.72	3720	1705
Plate-and-Frame	9	0.4	112	10.4	3.15	5600	5600
Hollow-Fiber	6	0.2	180	16.7	2.57	3600	3600
*Based on processing 100 gal/day (3.8 m <sup>3</sup> /day).							

Electrical costs for processing 1000 gal/day (3.8 m<sup>3</sup>/day) of raw sewage is lowest for the hollow-fiber membrane system. This system also has the highest packing density (surface area/system volume) of the three systems. However, operating problems encountered in this study indicate that this membrane cartridge would plug with activated sludge within the first few weeks to months of operation. Consequently, this membrane system would not be suitable for processing activated sludge due to extensive pretreatment and maintenance requirements. The plate-and-frame system's electrical costs are second to hollow-fiber when the average fluxes of Table 8 are considered. However, these costs are higher than the

hollow-fiber and tubular systems when the data are based on the lowest flux. Initial and replacement membrane costs of the plate-and-frame system are the highest of the three configurations.

The results of this study have shown that only the plate-and-frame membrane system passed fecal coliform bacteria to the permeate. Such behavior has been reported by other investigators testing this membrane. If this system is to be considered for processing activated sludge, a postdisinfection step must be employed to guarantee an effluent satisfying the marine discharge requirement.

The tubular system has the poorest packing density of the three systems. However, it has the highest overall flux; and, therefore, the surface area required to process the activated sludge is lower than the other membrane systems. When the average flux is considered, the tubular system shows the highest electrical costs. This is due to the high circulation rate required to retard membrane fouling. Recent experience with tubular UF systems at the Center using lower circulation rates without encountering fouling problems indicates that these costs can be reduced by 25%-33%. When the lowest flux is considered, the tubular membrane's electrical costs are comparable to the hollow fiber. Consequently, the tubular membrane system: (1) requires minimal, if any, pretreatment, (2) shows fluxes 2 to 3-fold greater than its nearest competitors, (3) shows comparable initial and lower membrane replacement costs than the other membranes, and (4) does not pass bacteria into the permeate or plug with concentrated activated sludge. Long-term tests of the tubular system are necessary to establish reliability and maintainability for shipboard application.

#### CONCLUSIONS AND FINDINGS

1. Ultrafiltration membranes can process activated sludge for extended periods on a noncontinuous basis (8-10 hours/day) without requiring cleaning operations.
2. A UF system is the only solid-liquid separation process currently available that can separate suspended solids and bacteria of sewage in a single operation.

3. Depressurization of a UF membrane system processing sewage appears to be an effective means of stabilizing membrane flux for more than 1 month without requiring chemical or physical cleaning.

4. Tubular UF membranes are more effective in processing activated sludge than plate-and-frame or hollow-fiber membranes.

5. Hollow-fiber UF membranes will eventually plug with concentrated activated sludge even when frequent cleaning operations are performed. However, the membranes do meet the 1981 marine discharge requirements.

6. Tubular UF membranes can effectively process activated sludge and produce an effluent satisfying the 1981 marine discharge requirements. The plate-and-frame membrane satisfies these requirements if postdisinfection is also performed.

#### ACKNOWLEDGMENT

The author acknowledges the support of Mr. M. Sandate, DTNSRDC co-op student from New Mexico State University, and Ms. D. Brown, Environmental Engineer, National Bureau of Standards, for their assistance in accomplishing this study.

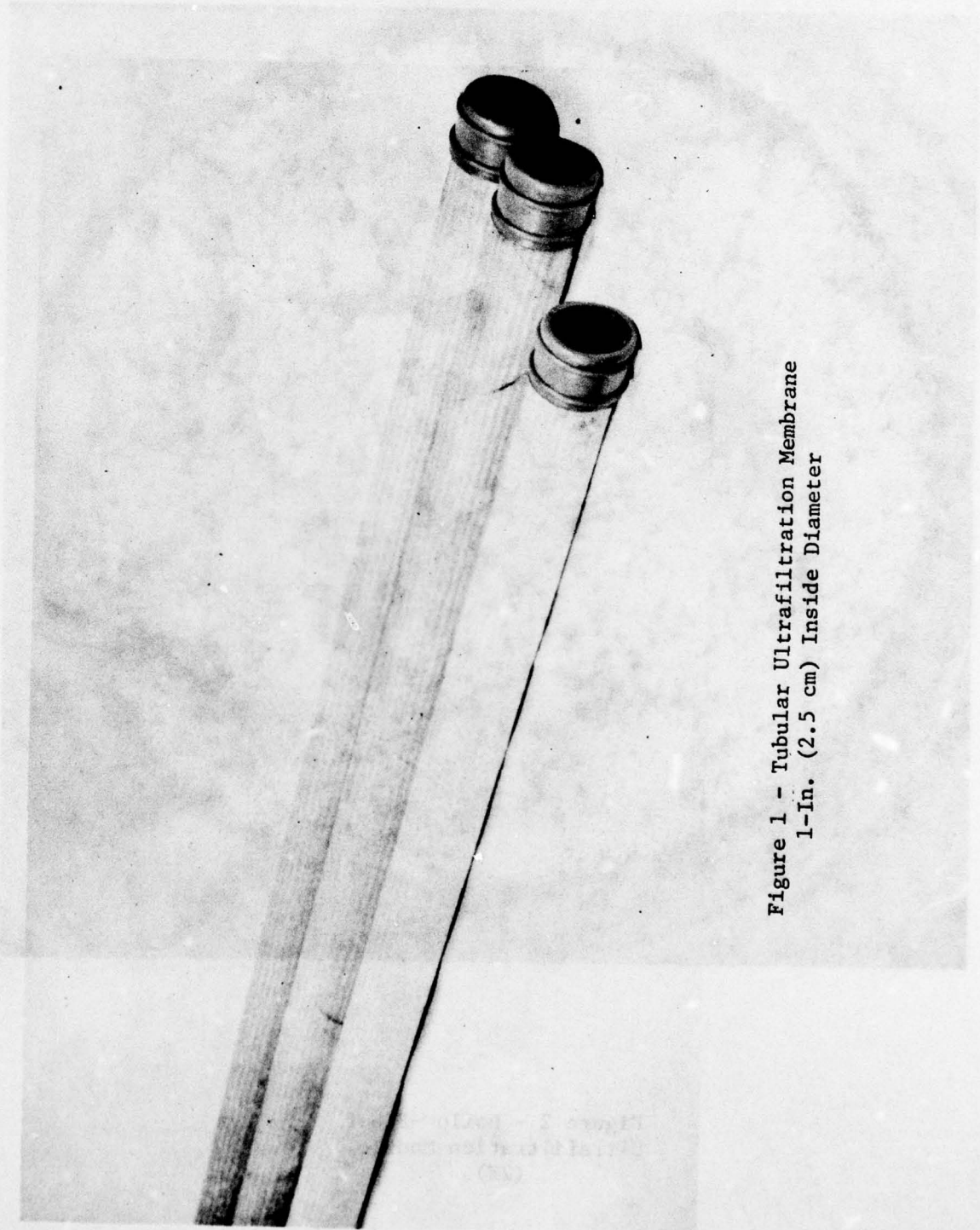

Figure 1 - Tubular Ultrafiltration Membrane  
1-In. (2.5 cm) Inside Diameter

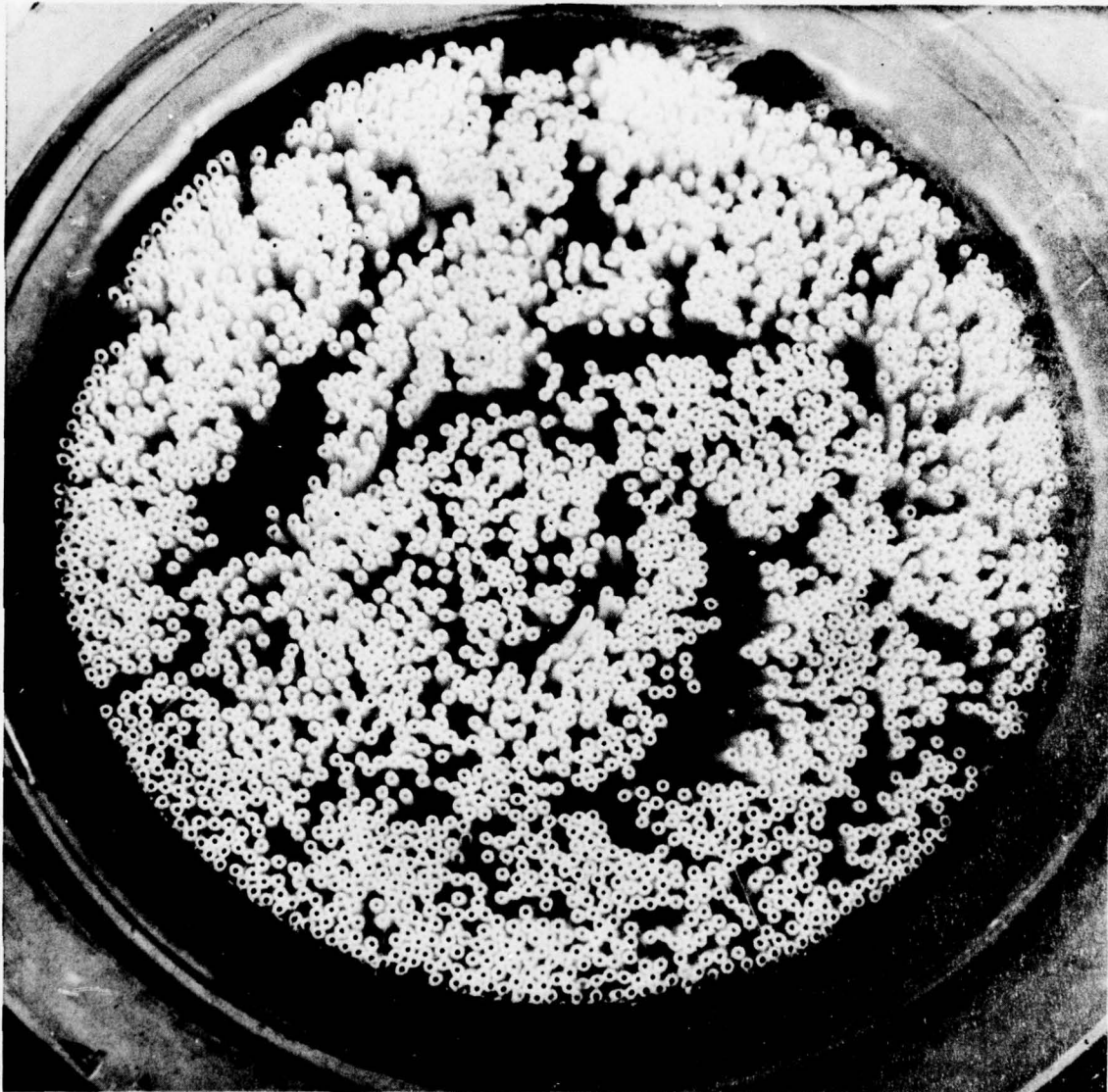

Figure 2 - Hollow-Fiber  
Ultrafiltration Module  
(2X)

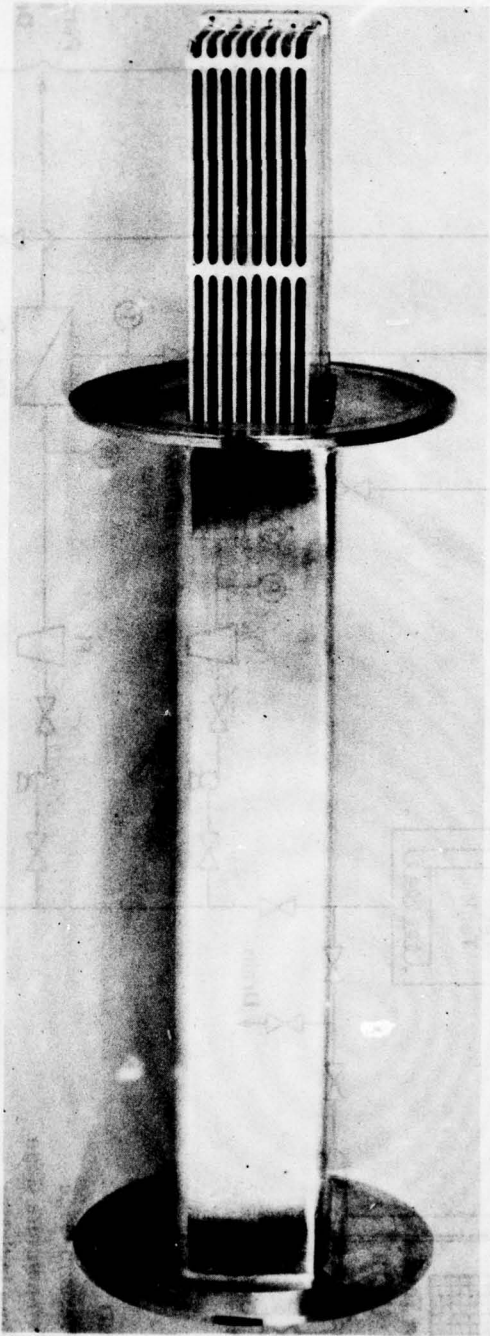
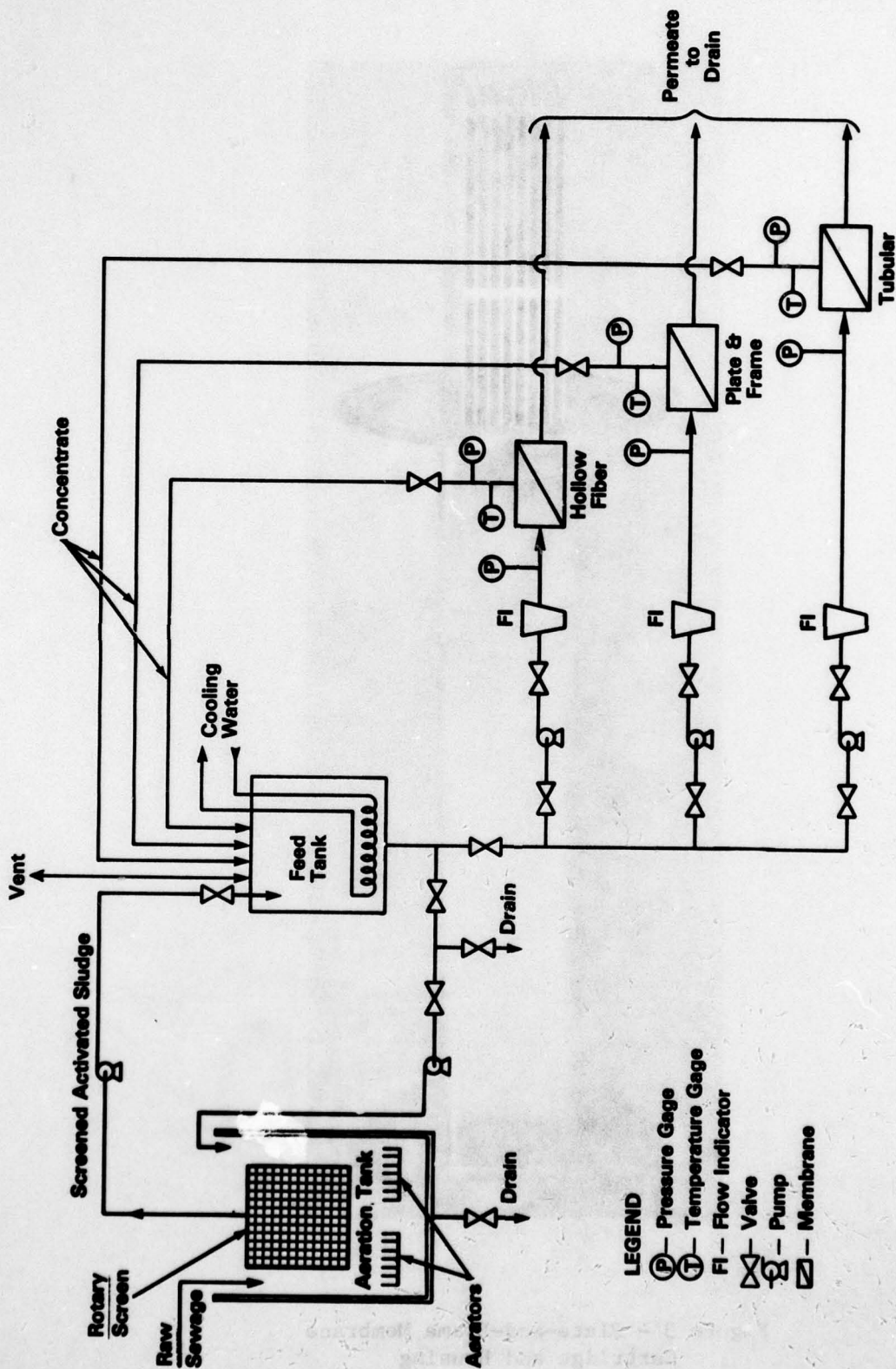

Figure 3 - Plate-and-Frame Membrane Cartridge and Housing



- LEGEND**
- (P) - Pressure Gage
  - (T) - Temperature Gage
  - FI - Flow Indicator
  - ⋈ - Valve
  - ⊠ - Pump
  - ▭ - Membrane

Figure 4 - Ultrafiltration Test Loop Schematic

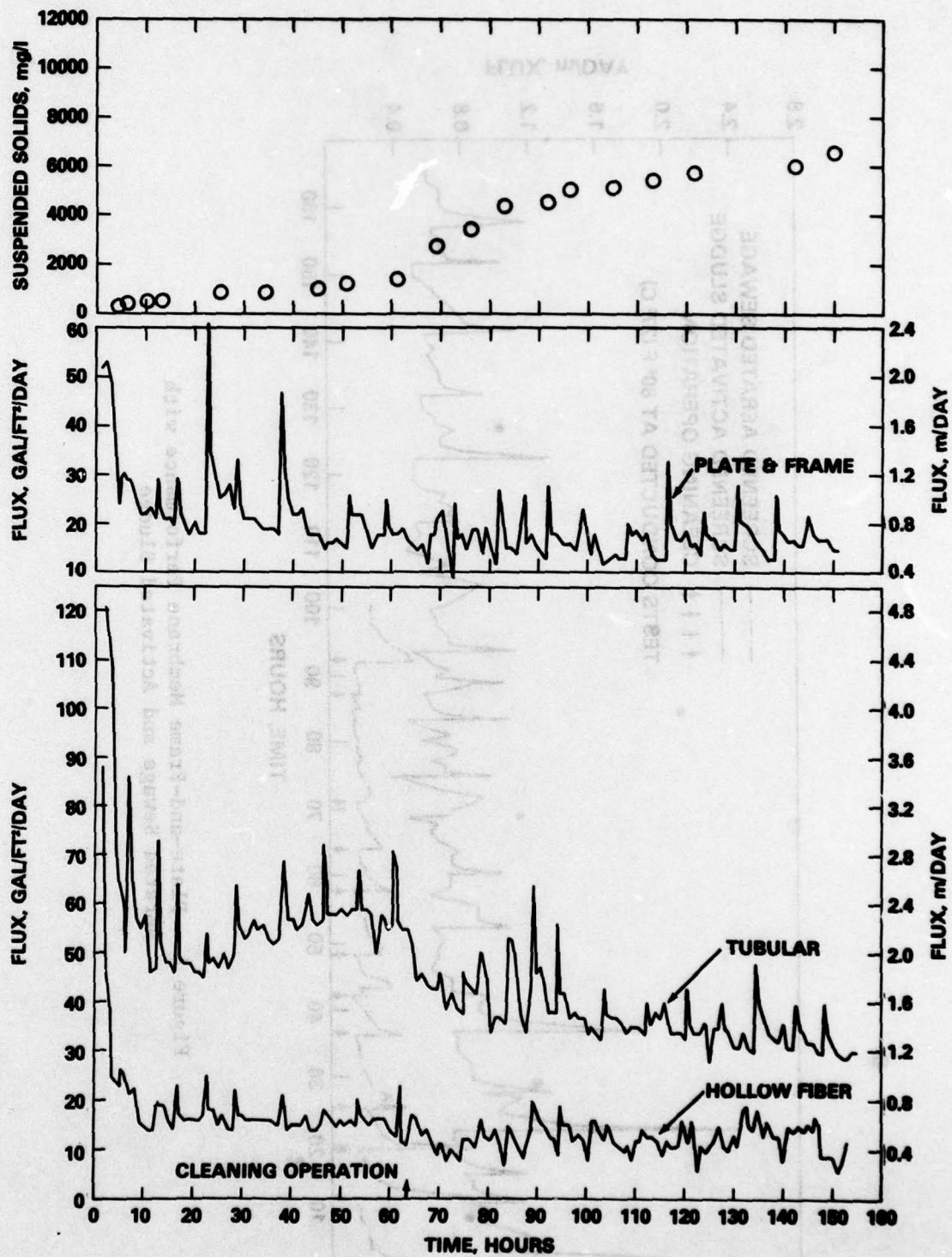

Figure 5 - Membrane Flux Curves

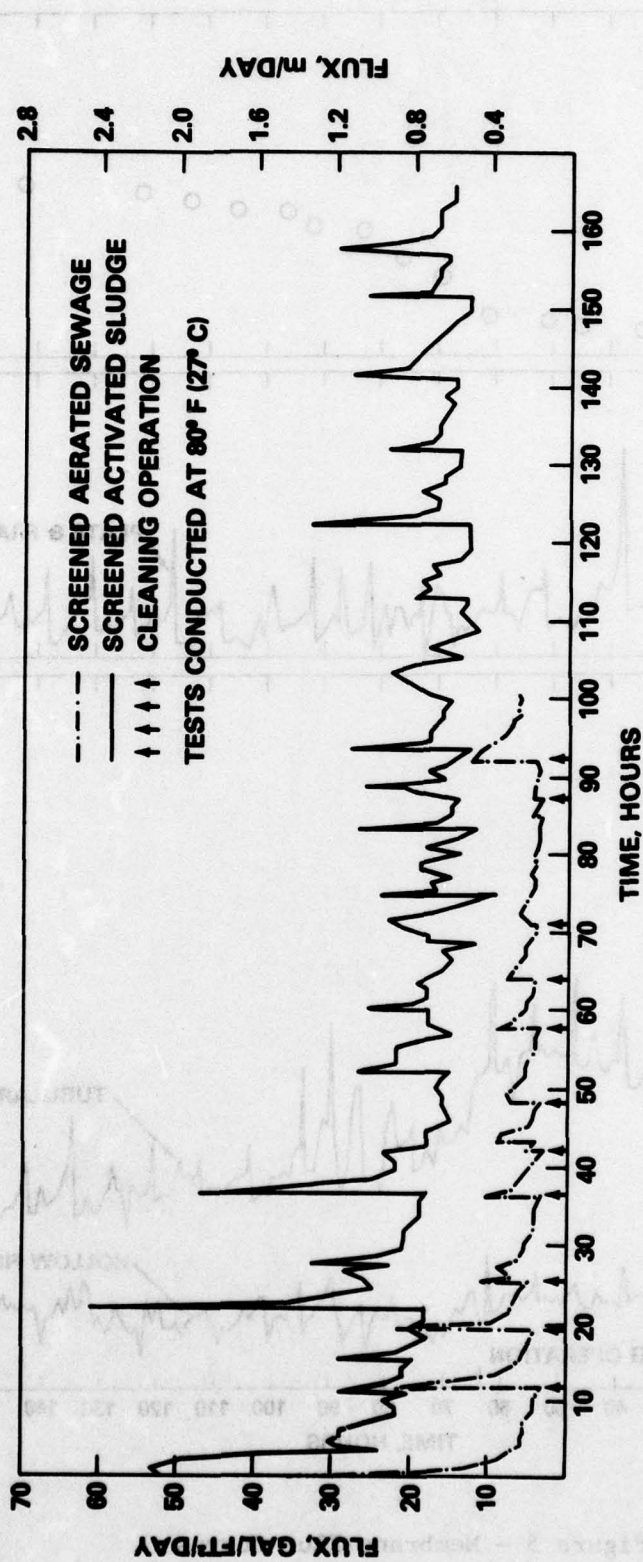

Figure 6 - Plate-and-Frame Membrane Performance with Aerated Sewage and Activated Sludge

APPENDIX A  
DAILY AVERAGE FLUX\*

Day	Membrane Configuration					
	Tubular		Hollow-Fiber		Plate-and-Frame	
1	71	(2.8)	31	(1.3)	39	(1.5)
2	58	(2.3)	19	(0.8)	25	(1.0)
3	53	(2.1)	18	(0.7)	23	(0.9)
4	49	(2.0)	17	(0.7)	20	(0.8)
5	49	(2.0)	17	(0.7)	33	(1.3)
6	55	(2.2)	17	(0.7)	22	(0.9)
7	58	(2.3)	16	(0.6)	25	(1.0)
8	59	(2.4)	16	(0.6)	16	(0.6)
9	58	(2.3)	16	(0.6)	20	(0.8)
10	51	(2.0)	14	(0.6)	18	(0.7)
11	41	(1.6)	9	(0.4)	17	(0.7)
12	42	(1.7)	12	(0.5)	17	(0.7)
13	42	(1.7)	12	(0.5)	18	(0.7)
14	46	(1.8)	15	(0.6)	17	(0.7)
15	39	(1.6)	13	(0.5)	18	(0.7)
16	36	(1.4)	12	(0.5)	16	(0.6)
17	36	(1.4)	12	(0.5)	16	(0.6)
18	35	(1.4)	12	(0.5)	18	(0.7)
19	33	(1.3)	13	(0.5)	17	(0.7)
20	35	(1.4)	14	(0.6)	18	(0.7)
21	33	(1.3)	14	(0.6)	18	(0.7)
22	32	(1.3)	11	(0.4)	19	(0.8)

\*gal/ft<sup>2</sup>/day.

APPENDIX B  
FLUX DECLINE RATES\*

Day	Membrane Configuration		
	Tubular	Hollow-Fiber	Plate-and-Frame
1	-0.56	-0.82	-0.35
2	-0.17	-0.14	-0.18
3	-0.07	-0.21	-0.09
4	-0.05	-0.01	-0.10
5	-0.00	-0.14	-0.19
6	-0.01	-0.04	-0.12
7	-0.05	0.01	-0.26
8	0.01	-0.04	-0.01
9	0.01	-0.08	-0.14
10	0.15	-0.04	-0.17
11	-0.06	-0.13	-0.11
12	-0.10	-0.08	-0.10
13	-0.06	-0.14	0.02
14	0.13	-0.31	-0.13
15	-0.10	-0.13	-0.05
16	-0.04	-0.16	-0.17
17	-0.05	-0.13	-0.19
18	-0.03	-0.30	-0.14
19	-0.05	-0.00	-0.08
20	-0.11	-0.17	-0.24
21	-0.09	-0.01	-0.09
22	-0.07	-0.22	-0.18
Average	-0.09	-0.15	-0.14
*gal/ft <sup>2</sup> /day <sup>2</sup> .			

**APPENDIX C**  
**DAILY TOTAL SUSPENDED SOLIDS CONCENTRATION\***

Day	Feed Tank	Permeate		
		Tubular	Hollow-Fiber	Plate-and-Frame
1	350	22	2	2
2	450	1	0	5
3	500	11	2	8
4	550	5	0	8
5	900	4	0	0
6	950	14	6	5
7	1000	20	17	20
8	900	6	10	5
9	1450	7	12	15
10	2850	0	8	1
11	3450	7	24	13
12	4300	34	11	13
13	4500	11	0	5
14	5150	16	5	3
15	5650	5	18	12
16	5420	0	0	0
17	5850	13	0	0
18	5800	-	-	-
19	6300	24	10	0
20	6400	29	21	12
21	6700	33	21	29
<b>Average</b>	<b>3300</b>	<b>8.0</b>	<b>9.0</b>	<b>14.0</b>

\*All figures in mg/l.

APPENDIX D  
DAILY FECAL COLIFORM BACTERIA CONCENTRATION\*

Day	Feed Tank	Permeate		
		Tubular	Hollow-Fiber	Plate-and-Frame
1	4.7X10 <sup>5</sup>	<10	<10	70
2	3.3X10 <sup>6</sup>	<10	<10	820
3	5.3X10 <sup>6</sup>	<10	<10	150
4	3.9X10 <sup>6</sup>	<10	<10	1000
5	2.1X10 <sup>7</sup>	<10	<10	600
6	1.0X10 <sup>7</sup>	<10	<10	50
7	1.8X10 <sup>7</sup>	<10	<10	70
8	1.3X10 <sup>7</sup>	<10	<10	70
9	-	-	-	-
10	1.0X10 <sup>5</sup>	<10	<10	<10
11	1.0X10 <sup>5</sup>	<10	<10	<10
12	2.0X10 <sup>5</sup>	<10	<10	<10
13	5.0X10 <sup>5</sup>	<10	<10	<10
14	5.0X10 <sup>4</sup>	<10	<10	<10
15	2.0X10 <sup>5</sup>	<10	<10	<10
16	6.0X10 <sup>4</sup>	<10	<10	<10
17	-	-	-	-
18	1.0X10 <sup>5</sup>	<10	<10	<10
19	5.0X10 <sup>4</sup>	<10	<10	<10
20	1.6X10 <sup>5</sup>	<10	<10	<10
21	2.3X10 <sup>6</sup>	<10	<10	<10

\*All figures in number of colonies/100 ml.

#### REFERENCES

1. Federal Register, Vol. 41, No. 71, p. 15324 (12 Apr 1976).
2. Harris, L.R. and C.M. Adema, "Processing of Raw Sewage by Ultrafiltration," DTNSRDC Report MAT-77-79 (Apr 1977).
3. Harris, L.R. et al., "Ultrafiltration of Black and Oily Wastewater," Paper No. 77/ENA-57, Presented at the 7th Intersociety Conference on Environmental Systems, San Francisco, CA (11-14 Jul 1977).
4. Hoover, P.R. et al., "Evaluation of Ultrafiltration and Disinfection for Treatment of Blackwater," U.S. Army Contract DAAG53-76-0083 (Jul 1977).
5. Bailey, J.R. et al., "Phase I Final Report, Shipboard Sewage Treatment System," Navy Contract N00024-71-5329 (Nov 1971).
6. "Standard Methods for the Examination of Water and Wastewater," 13th Ed., American Public Health Association, Washington, D.C. (1971).
7. Weisman, B.J. et al., "Performance of Membrane Systems in Treating Water and Sewage," Chemical Engineering Symposium Series, Water, pp. 289 (1968).
8. Hinterberger, J.A. et al., "Use of Reverse Osmosis and Ultrafiltration for Removing Microorganisms from Water," Report 2111, Sanitary Science Division, U.S. Army MERADCOM, Ft. Belvoir, VA (Sep 1976).
9. Personal communication with A.T. Geyer and W. van Hees of DTNSRDC (Feb 1977).

INITIAL DISTRIBUTION

Copies		CENTER DISTRIBUTION	
		Copies	Code
1	U.S. Army MERADCOM (Attn: G. Eskelund)	1	2809H
1	CHNAVMAT (MAT 08T241)	4	286
6	NAVSEA	1	2861
	1 SEA 03C	1	2861
	1 SEA 04E	7	2861 (C.M. Adema)
	1 SEA 05R14	1	2862 (S.M. Finger)
	1 SEA 534		
	2 SEA 99612		
12	DDC	1	522.1
1	Department of Interior Office of Water Research and Technology (Attn: Mr. M. Matson)	2	5231
5	National Institute of Occupational Safety and Health Room 8A-45 5600 Fishers Lane Rockville, Md. 20857 (Attn: Mr. L.R. Harris)		

**DTNSRDC ISSUES THREE TYPES OF REPORTS**

**1. DTNSRDC REPORTS, A FORMAL SERIES, CONTAIN INFORMATION OF PERMANENT TECHNICAL VALUE. THEY CARRY A CONSECUTIVE NUMERICAL IDENTIFICATION REGARDLESS OF THEIR CLASSIFICATION OR THE ORIGINATING DEPARTMENT.**

**2. DEPARTMENTAL REPORTS, A SEMIFORMAL SERIES, CONTAIN INFORMATION OF A PRELIMINARY, TEMPORARY, OR PROPRIETARY NATURE OR OF LIMITED INTEREST OR SIGNIFICANCE. THEY CARRY A DEPARTMENTAL ALPHANUMERICAL IDENTIFICATION.**

**3. TECHNICAL MEMORANDA, AN INFORMAL SERIES, CONTAIN TECHNICAL DOCUMENTATION OF LIMITED USE AND INTEREST. THEY ARE PRIMARILY WORKING PAPERS INTENDED FOR INTERNAL USE. THEY CARRY AN IDENTIFYING NUMBER WHICH INDICATES THEIR TYPE AND THE NUMERICAL CODE OF THE ORIGINATING DEPARTMENT. ANY DISTRIBUTION OUTSIDE DTNSRDC MUST BE APPROVED BY THE HEAD OF THE ORIGINATING DEPARTMENT ON A CASE-BY-CASE BASIS.**