

AD-A073 660

UNITED TECHNOLOGIES CORP SUNNYVALE CALIF CHEMICAL SY--ETC F/G 9/1
THE DEVELOPMENT OF IMPROVED NORMAL STRESS TRANSDUCERS FOR PROPE--ETC(U)

JUN 79 E C FRANCIS, R E THOMPSON, W E BRIGGS F04611-75-C-0042

UNCLASSIFIED

CSD-2548-FR-VOL-2

AFRPL-TR-79-34-VOL-2

NL

1 of 4

AD
A073660

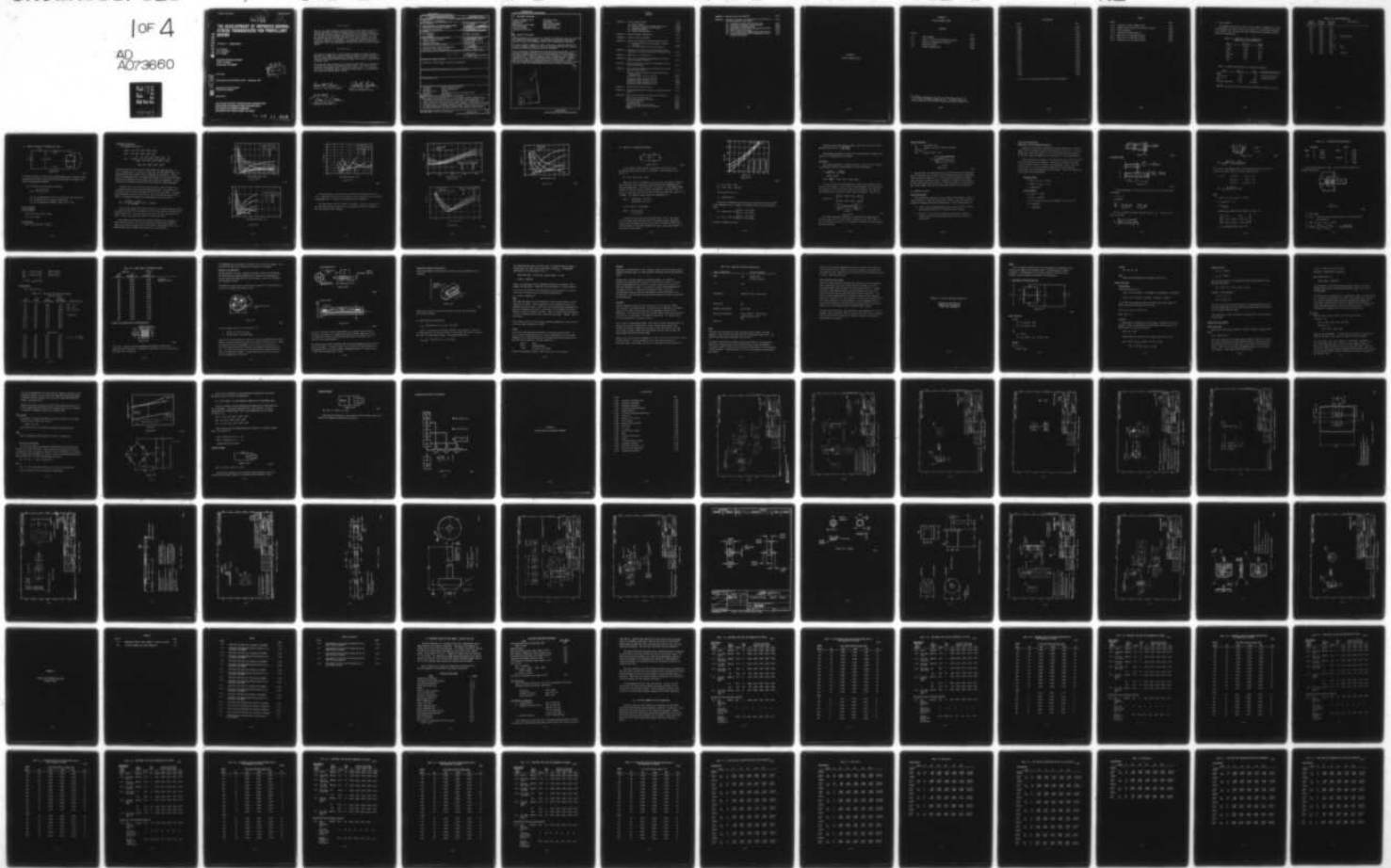

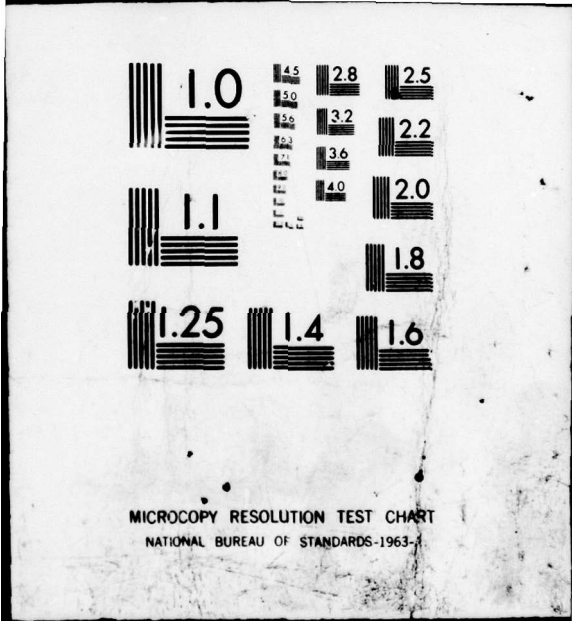

LEVEL

A073659

(Handwritten signature)

THE DEVELOPMENT OF IMPROVED NORMAL STRESS TRANSDUCERS FOR PROPELLANT GRAINS

Volume II — Appendices

E. C. Francis
R. E. Thompson
W. E. Briggs

Chemical Systems Division
1050 E. Arques
Sunnyvale, CA 94086

June 1979

Final Report for Period March 1975 — December 1978

Approved for Public Release
Distribution Unlimited

Prepared for

AIR FORCE ROCKET PROPULSION LABORATORY
DIRECTOR OF SCIENCE AND TECHNOLOGY
AIR FORCE SYSTEMS COMMAND
EDWARDS AIR FORCE BASE, CA 93523

DDC
RECEIVED
SEP 11 1979
A

A 073660

DDC FILE COPY

79 09 11 010

NOTICES

When U.S. Government drawings, specifications, or other data are used for any purpose other than a definitely related Government procurement operation, the Government thereby incurs no responsibility nor any obligation whatsoever, and the fact that the Government may have formulated, furnished, or in any way supplied the said drawings, specifications, or other data is not to be regarded by implication or otherwise, or in any manner licensing the holder or any other person or corporation, or conveying any rights or permission to manufacture, use or sell any patented invention that may in any way be related thereto.

FOREWORD

This report was submitted by United Technologies/Chemical Systems Division, Sunnyvale, CA 94086, under contract F04611-75-C-0042, JON 573013 FH with the Air Force Rocket Propulsion Laboratory, Edwards AFB, CA 93523. The report summarizes the technical efforts conducted under this contract from March 1975 to December 1978.

This report has been reviewed by the Information Office/XOJ and is releasable to the National Technical Information Service (NTIS). At NTIS it will be available to the general public, including foreign nations. This technical report has been reviewed and is approved for publication; it is unclassified and suitable for general public release.

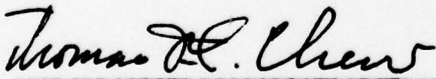

Thomas J.C. Chew, Project Manager

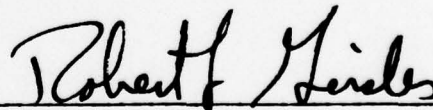

Robert L. Geisler, Chief
Propellant Development Branch

FOR THE COMMANDER

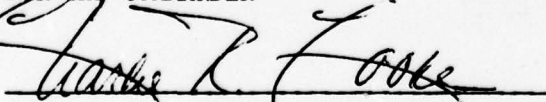

Charles R. Cooke, Director
Solid Rocket Division

UNCLASSIFIED

SECURITY CLASSIFICATION OF THIS PAGE (When Data Entered)

19 REPORT DOCUMENTATION PAGE		READ INSTRUCTIONS BEFORE COMPLETING FORM	
1. REPORT NUMBER AFRPL-TR-79-34-Volume II-2	2. GOVT ACCESSION NO.	3. RECIPIENT'S CATALOG NUMBER	
4. TITLE (and Subtitle) THE DEVELOPMENT OF IMPROVED NORMAL STRESS TRANSDUCERS FOR PROPELLANT GRAINS, Volume II, Appendices		5. TYPE OF REPORT & PERIOD COVERED Final Report for March 1975 - December 1978	
7. AUTHOR(s) E. C. Francis R. E. Thompson W. E. Briggs		6. PERFORMING ORG. REPORT NUMBER CSD-2548-FR-101-2	
9. PERFORMING ORGANIZATION NAME AND ADDRESS Chemical Systems Division 1050 E. Arques Sunnyvale, CA 94086		8. CONTRACT OR GRANT NUMBER(s) F04611-75-C-0042	
11. CONTROLLING OFFICE NAME AND ADDRESS Air Force Rocket Propulsion Laboratory Edwards Air Force Base, CA 93523		10. PROGRAM ELEMENT, PROJECT, TASK AREA & WORK UNIT NUMBERS Program Element 62302 F Project 5730 Task 13 JON: 573013FH	
14. MONITORING AGENCY NAME & ADDRESS (if different from Controlling Office) 12 341p.		12. REPORT DATE 11 June 1979	
		13. NUMBER OF PAGES 621 Vol. II - 342	
		15. SECURITY CLASS. (of this report) Unclassified	
		15a. DECLASSIFICATION DOWNGRADING SCHEDULE N/A	
16. DISTRIBUTION STATEMENT (of this Report) Approved for Public Release; Distribution Unlimited			
17. DISTRIBUTION STATEMENT (of the abstract entered in Block 20, if different from Report)			
18. SUPPLEMENTARY NOTES			
19. KEY WORDS (Continue on reverse side if necessary and identify by block number) Transducer Finite element analysis Diaphragm Stress disturbance Cantilevered Beam Axiality Leadwires Transducer/propellant interaction factor Calibration Zero offset			
20. ABSTRACT (Continue on reverse side if necessary and identify by block number) This report details the CSD effort in the design, analysis, manufacturing, calibration, and embedded use of improved normal stress transducers. Prototype transducers from two different contractors were manufactured and tested as well as final production transducer models. Finite element analysis techniques used for transducer analysis are extensively covered and were used for design optimization and gage interpretation. Results covering gaseous nitrogen calibrations, long term stability, self-heating, diode effects,			

391 927

19. KEY WORDS (Continued)

Stress disturbance factor
 Constant current
 Sensitivity
 Semiconductor strain gage
 Foil strain gage
 Stress transducer
 Gage/grain interaction

Full-scale output
 EB welding
 Glass-to-metal header
 Epoxy bond stability
 Metal stability
 Transducer stability

20. ABSTRACT (Continued)

embedded thermal and pressurization loadings, and mechanical tests are presented and compared with design goals. Detailed manufacturing specifications are presented along with recommended calibration and installation techniques.

The final transducer design is 0.130-in. high with an external prewired compensation package. Stability of the metal and epoxy bond has been optimized by special processing techniques which are presented.

Several significant achievements were obtained during the program. The first computerized design tradeoff curves were generated for stress transducers. Successful electron beam welding of critical components on stress transducers was demonstrated. Transducer measured stress in propellant was verified independently in the tension-compression-shear and TM-1 devices. Transducer response under high rate loading conditions was demonstrated. Agreement between predicted and measured stresses for a thermal loaded solid propellant motor using the thermal-mechanical interaction factor was achieved.

Accession For	
NTIS G.I.A.I	
DDC TAB	
Unannounced	
Justification	
By	
Distribution/	
Availability Codes	
Dist.	Avail and/or special
A	

VOLUME II
CONTENTS

APPENDIX A: Celesco Tradeoff Study	A-283
A-1 Cable Tradeoff	A-287
A-2 Theory of Sensitivity Compensation Curves	A-298
A-3 Sensitivity Compensation Procedure	A-295
A-4 Mechanical Design	A-298
A-5 Chemical Compatibility	A-308
APPENDIX B: Celesco Tradeoff Compensation	B-313
APPENDIX C: Celesco Prototype Drawings	C-323
APPENDIX D: Celesco P-95 Transducer 500-Hour Stability Data	D-347
1.0 Transducer Satbility Data Summary - Celesco P-95 Data	D-351
2.0 P-95 Data Summary for Seven Transducers	D-353
APPENDIX E: Comparison of 17-4 PH and 15-5 PH Stainless Steel Properties Precipitation Hardenable Stainless Steel	E-381
APPENDIX F: ARMCO Data - 15-5 PH VAC CE	F-395
APPENDIX G: Stress in the Transducer Diaphragm Due to Thermal Shock During Heat Treatment	G-419
APPENDIX H: Plastic Deformation Analysis of Diaphragm for Over- pressure Conditions	H-427
APPENDIX I: Minco Platinum Temperature Sensor Specification and and Calibration Tables	I-439
Article, "Precision Miniature Platinum Resistance Thermometers"	I-443
Calibration Table, Resistor S/N 229	I-451
Calibration Table, Resistor S/N 230	I-459
Calibration Table, Resistor S/N 231	I-464
Calibration Table, Resistor S/N 232	I-469
Calibration Table, Resistor S/N 233	I-474
APPENDIX J: Vishay Resistor Stability Data	J-479
APPENDIX K: Instrumented Beam Test Procedure and Troubleshooting Guides	K-499
APPENDIX L: Epoxy Creep Evaluation Test Uncertainty Analysis	L-513
Semiconductor Gage Evaluation	L-515
Epoxy Creep Evaluation Flow Chart	L-518
Foil Gage Evaluation	L-519
Problem Shooting	L-520
Cantilevered Beam Strain Analysis	L-523
Cantilevered Beam Strain Error Analysis	L-524
Summary	L-527

APPENDIX M: General Uncertainty Analysis	M-529
APPENDIX N: Drawings, Processes, Specifications of the 601156 Low Profile Transducer Final Design	N-561
N-1 Transducer Drawing Guide and Parts List	N-563
N-2 Low Profile Transducer Design Drawings	N-569
N-3 Preparation of Gaging Surface	N-589
N-4 Semiconductor Strain Gage Installation Procedure	N-593
N-5 Epoxy Filtering Procedure	N-611
N-6 15-5 Stainless Steel Metal Conditioning Process	N-613
N-7 Technical Specification for Homogeneous Semiconductor Strain Gages	N-615

APPENDIX A
CELESCO TRADEOFF STUDY

APPENDIX A
CELESCO TRADEOFF STUDY¹

CONTENTS

Section		Page
A-1	Cable Tradeoff	A-287
A-2	Theory of Sensitivity Compensation Curves	A-289
A-3	Sensitivity Compensation Procedure	A-295
A-4	Mechanical Design	A-298
A-5	Chemical Compatibility	A-308

¹ "An Analytical Approach to Silicon Strain Gage Sensor Design," by P. A. LaClaire of Celesco Industries, Inc. Instrument Society of America, Copyright 1975 (75-706), Milwaukee, Wisconsin, October 1975.

ILLUSTRATIONS

Figure	Page
A-201	A-289
A-202	A-291
A-203	A-291
A-204	A-292
A-205	A-293
A-206	A-293
A-207	A-294
A-208	A-295
A-209	A-296
A-210	A-297
A-211	A-298
A-212	A-300
A-213	A-300
A-214	A-301
A-215	A-302
A-216	A-304
A-217	A-305
A-218	A-306
A-219	A-306
A-220	A-307

No titles to the figures were supplied by the subcontractor

TABLES

Tables		Page
A- 50	Conductors, Physics Handbook Data	A-287
A- 51	Commercially Available #32 Equivalent Conductor	A-287
A- 52	Cable Information	A-288
A- 53	Diaphragm and Beam Dimensions	A-302
A- 54	Beam Strain vs Diaphragm Thickness	A-303
A- 55	Beam Strain vs Diaphragm Thickness	A-304
A- 56	Propellant Corrosive Possibilities	A-310

A-1 CABLE TRADEOFF

The largest cable size consistent with the 0.125-in.-diameter hole allowed in the package skin comes out to be a 4-conductor, No. 32 equivalent conductor size, 0.010-in. wall thickness FEP Teflon insulation and an external braided shield No. 32 equivalent.

TABLE A- 50. CONDUCTORS, PHYSICS HANDBOOK DATA
(Data for No. 32 at 78°F only)

Type	Ohms/ft	X100
Silver	0.155	15.5
Copper	0.164	16.4
Gold	0.232	23.2
Platinum	0.952	95.2
Monel	4.00	400
Invar	7.71	771

TABLE A- 51. COMMERCIALY AVAILABLE #32 EQUIVALENT CONDUCTOR

Type	Ohms/ft	X100	Temperature Coefficient
Copper	0.17	17	Not given by supplier. Assumed 30%/100°F
Silver/copper	0.20	20	
Monel	4.5	450	
Stainless steel 304*	7/20	700/2,000	

*Must be less than 5.5 Ω/ft to meet safety requirement; difficult to solder

TABLE A-52. CABLE INFORMATION

Cable, (ohms/ft)	550 Ω RB, (length)	275 Ω RB, (length)	Cable material
10.0	35.4	17.7	
9.0	37.8	18.9	
8.0	40.6	20.3	
7.0	44.0	22.0	} Stainless steel
6.0	47.6	23.9	
5.5	50.0	25.0	
5.0	52.4	26.2	
4.0	57.9	28.9	} Monel
3.0	64.7	32.3	
2.0	73.3	36.6	
1.0	84.6	42.3	Platinum

A-2 THEORY OF SENSITIVITY COMPENSATION CURVES

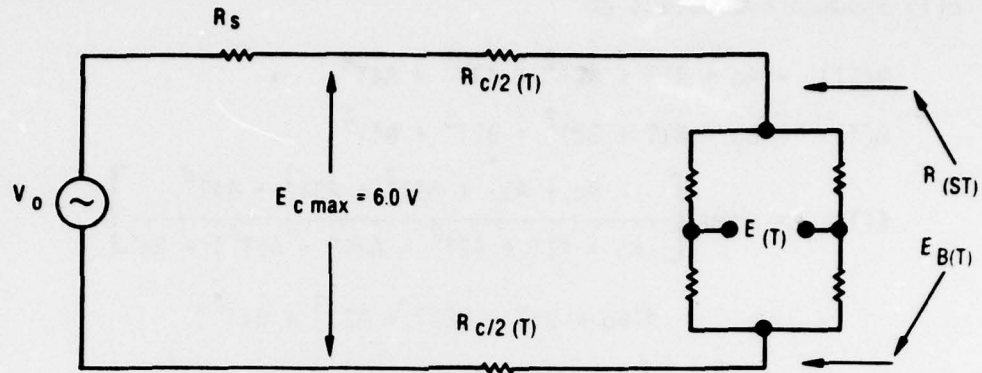

Figure A-201

17673

If the four resistors of the bridge are approximately equal, then the bridge resistance will be $R(sT)$; the voltage across the bridge will be $E_B(T)$; the output voltage from the bridge E .

$E(T)$ is given by the functional relationship

$$E(T) = \frac{E_B(T) G(T) \epsilon(T) N}{4}$$

$G(T)$ is the temperature function for the strain gage, gage factor

N is the number of active gages in the bridge

$\epsilon(T)$ is the temperature dependent strain at full load.

Circuit Solution

Total Resistance

$$R(T) = R's + RC/2 + R(ST) + RC/2$$

$$R(T) = R's + R(ST)$$

Bridge Voltage

$$EB(T) = V_o \left[\frac{R(ST)}{R's + R(ST)} \right]$$

Full-Scale Strain $\epsilon(T)$

$\epsilon(T)$ assumed a constant ϵ_0

$$R(ST) = A_0 + A_1T + A_2T^2 + A_3T^3 + A_4T^4$$

$$G(T) = B_0 + B_1T + B_2T^2 + B_3T^3 + B_4T^4$$

$$E(T) = V_{oco} \left[\frac{A_0 + A_1T + A_2T^2 + A_3T^3 + A_4T^4}{(A_0 + A_1T + A_2T^2 + A_3T^3 + A_4T^4) + R_s'} \right] \\ \times (B_0 + B_1T + B_2T^2 + B_3T^3 + B_4T^4)$$

The coefficients for $R(sT)$ and $G(T)$ are different for each gage type. If $E(T)$ is computerized, its solution is simple over any temperature range. The following curves show the most likely candidates for this design. Percent error is plotted against R 's, the sense comp resistor and the cable resistance. Coefficient of expansion for the metal used is taken as a parameter. In real life (5.0 to 7.0) would cover most metals used for strain gage transducers.

"Percent Error" in this work means Error Band in which the sensitivity is expected to remain over the entire temperature range. For example, Figure A-202, the 6.5 curve has a minimum of 1.8% at $R_s = 2,500$ ohms. This means that the maximum error due to sensitivity over the temperature range -75°F to 165°F is not expected to exceed 1.8% where percent error is defined as

$$\text{ERR} = \left| \frac{E(T)_{\text{max}} - E(T)_{\text{min}}}{E(T)_{\text{average}}} \right| \quad R's = \text{constant}$$

Figures A-202 through A-207 show the results of the Celesco computer analysis. The higher the coefficient of expansions for the force collector the smaller the expected sense error. Next the lower the minimum, the lower the comp resistor value. Finally, the lower the minimum the narrower the curve.

The curves also assume that the attachment temperature for the gages is 278°F (normal practice). The table in the corner of each figure gives the compression load on the gage for each coefficient of expansion at -75°F . For maximum stability this number should be kept as low as possible.

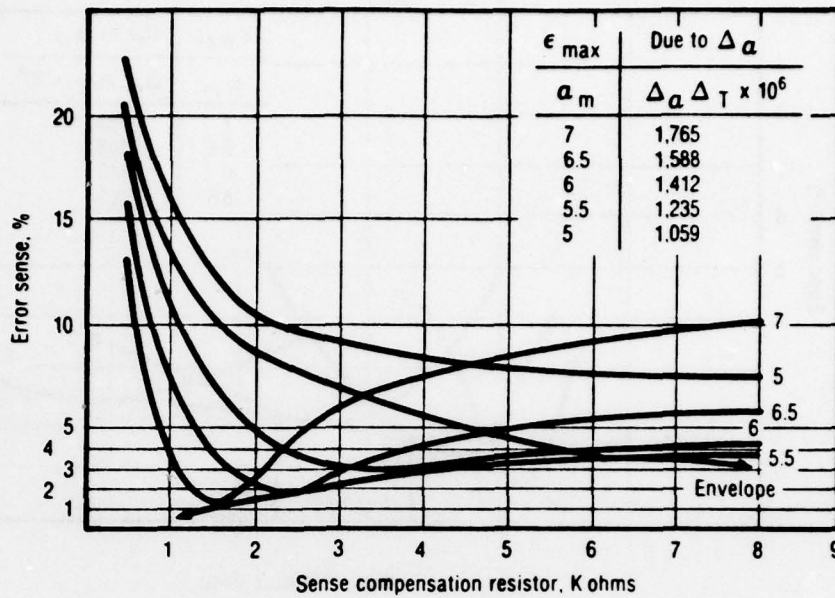

Figure A-202

17674

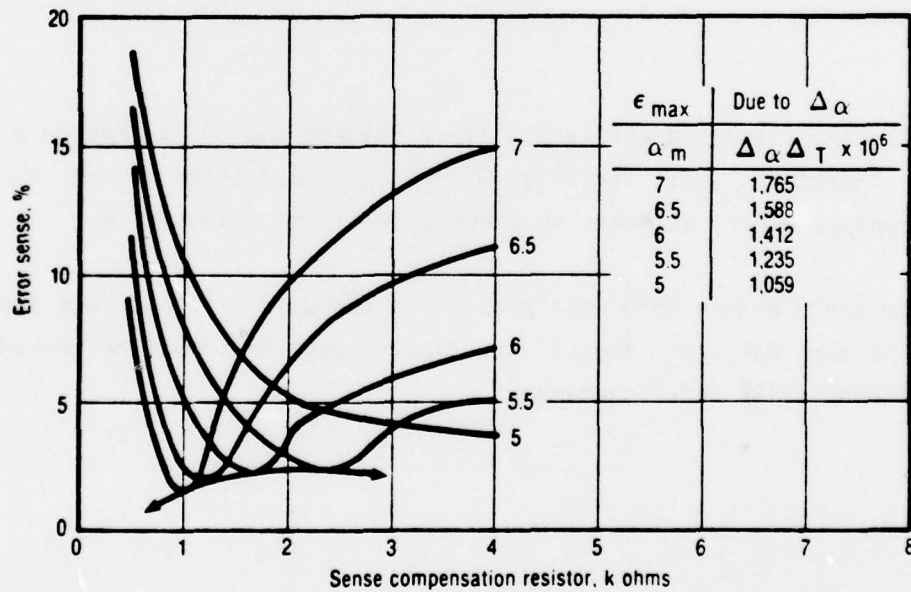

Figure A-203

17675

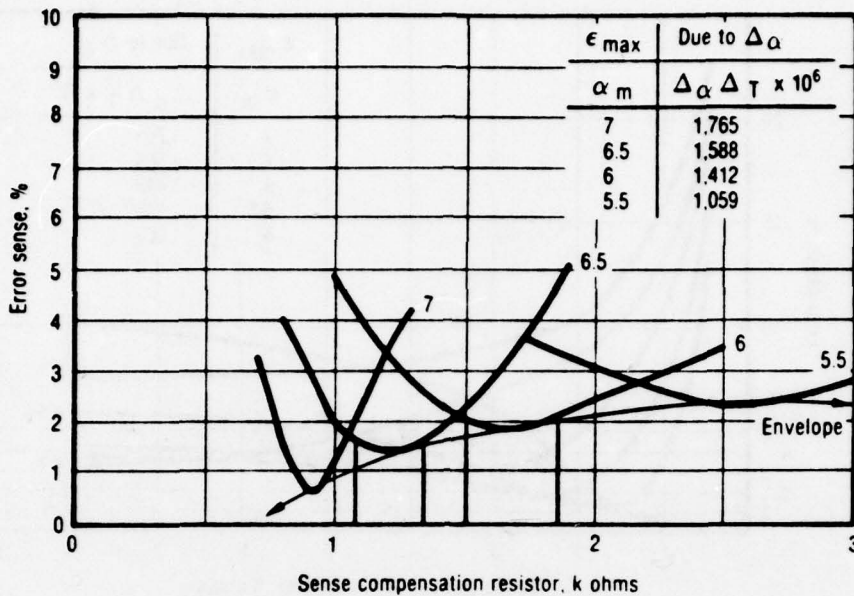

Figure A-204

17676

The data assumes a constant battery voltage and 500 microstrain as full scale. Therefore, $E_B(T)$ varies as R's varies. But since we are only interested in percentage error, it makes no difference to the calculation.

The cable enters into this problem in two ways: (1) It is a fraction of the sense comp resistor, and (2) the line voltage drop must be considered in the "intrinsically safe" statement.

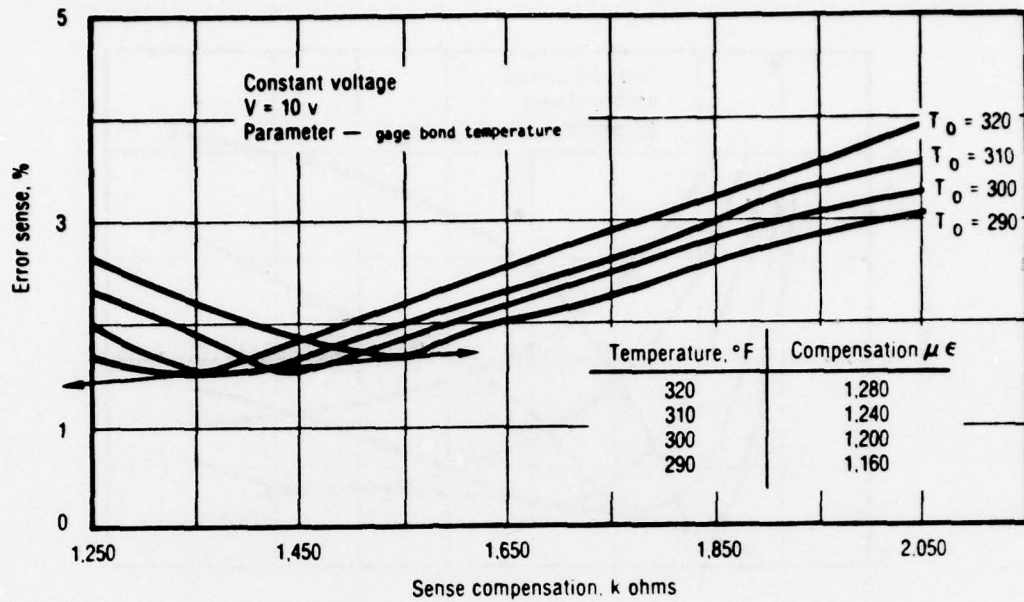

Figure A-205

17692

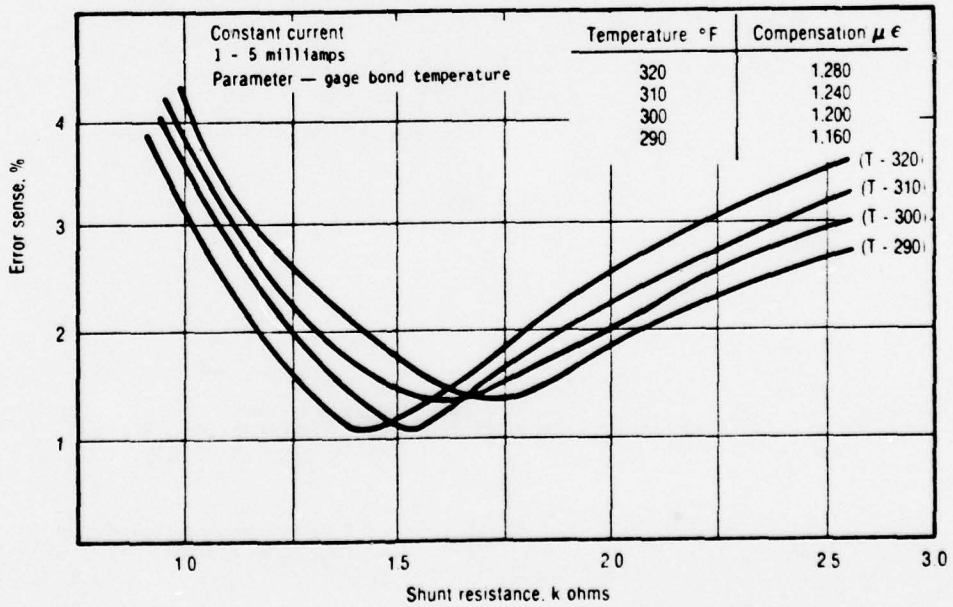

Figure A-206

17693

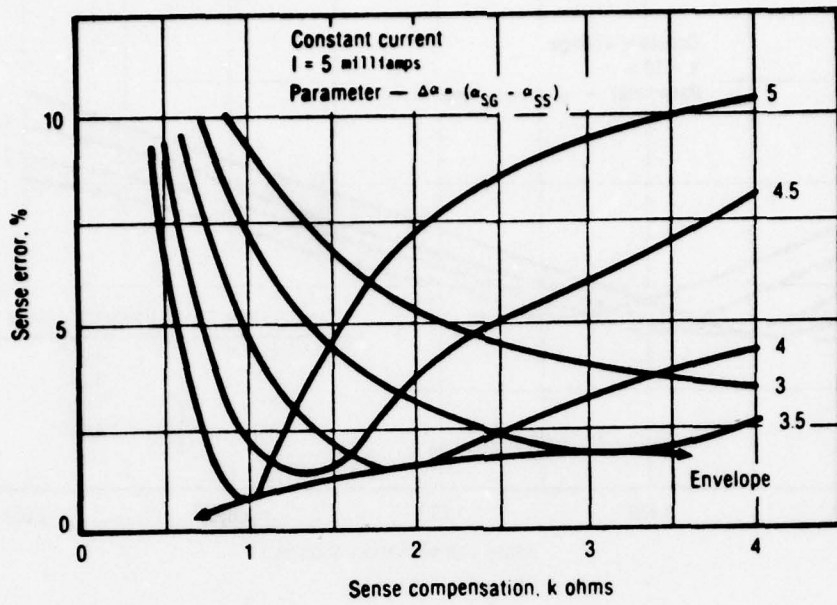

Figure A-207

17694

A-3 SENSITIVITY COMPENSATION PROCEDURE

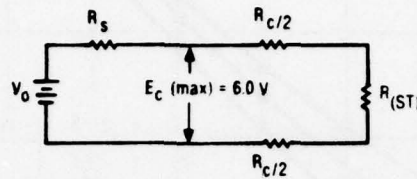

Figure A- 208

17678

For the typical Celesco bonded semiconductor strain gage bridge, the nominal sensitivity resistor is 1,750 ohms. The resistance of the circuit is:

$$R_s' = R_s + R_c/2 + R(sT) + R_c/2$$

After the circuit is compensated for sensitivity the battery voltage V_0 may be scaled to any value without interfering with the compensation for a desired bridge output. The restriction on scaling V_0 is that $E_c(max)$ cannot exceed 6.0 V due to "intrinsic safety" requirements. The value of $R(sT)$ is given in Figure A-209 for the 17-4 condition over the temperature range of -75° to $165^{\circ}F$. The required bridge voltage for compensation is:

$$EB(T) = \begin{bmatrix} V_0(540/540 + R_s) \text{ max} \\ V_0(330/330 + R_s) \text{ min} \end{bmatrix}$$

For $V_0 = 10V$, $R_s = 1,750$ ohms

$$EB(T) = \begin{bmatrix} 2.36 \text{ V max} \\ 1.58 \text{ V min} \end{bmatrix}$$

To be on the safe side, let us use $EB(T) \text{ max} = 3.0 \text{ V}$. This leaves 3.0 V for cable drop restricted by the "intrinsically safe" requirement. Further, this also means that the maximum cable resistance at $165^{\circ}F$ cannot exceed 550 ohms, or each 50 ft conductor 275 ohms. Using these numbers in the relation for R's gives

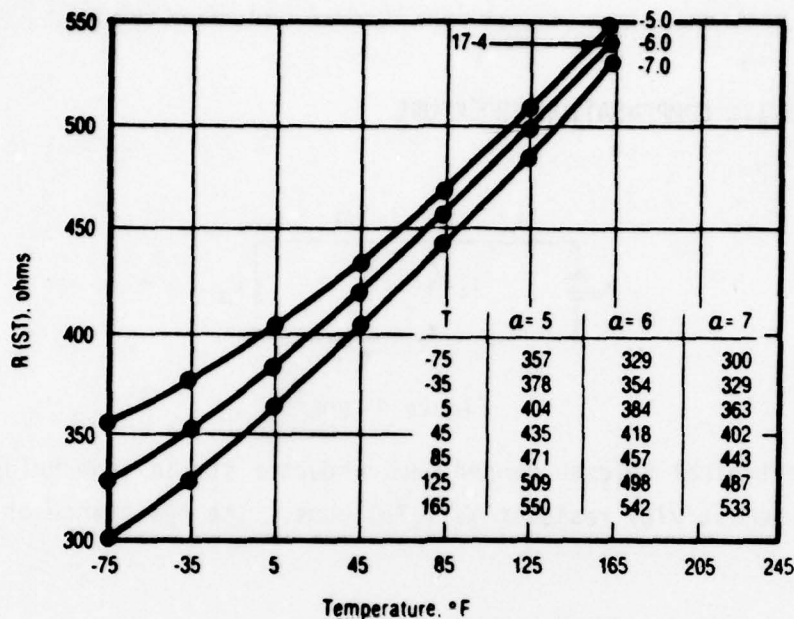

Figure A-209

17679

$$R_s = R's - (RC/2 + RC/2)$$

$$R_s = 1,750 - 550 = 1,250 \text{ ohms}$$

The deviation for R's is

$$R's = (d(RC/2)/dT) \Delta T$$

Using Physics Handbook data and using an outside worst-case of 5%/100°F as the temperature rate of change of resistance for the wire, with positive slope,

$$R's = (\text{Monel}) 400 \times 0.05 \begin{cases} \times 0.87 = 17.4 \text{ ohms} \\ \times 1.53 = -30.6 \text{ ohms} \end{cases}$$

$$R's = (\text{S.S.}) 700 \times 0.05 \begin{cases} \times 0.87 = 30.4 \text{ ohms} \\ \times 1.53 = -53.5 \text{ ohms} \end{cases}$$

for cable resistance deviation.

Referring to the (6.0) curve of Figure A-204 shows that the allowable deviation for 2% max is $\begin{bmatrix} 200 \text{ ohms} \\ -250 \text{ ohms} \end{bmatrix}$

Both allowances exceed by a factor of 10 the deviations for Monel and a factor of 5 the deviations for stainless.

Zero Slope

Zero slope adjustment is a rotation function. The rule to be followed is obtained by looking at the derivative of the bridge output,

$$E = V_0 \left[\frac{R_2}{R_1 + R_2} - \frac{R_3}{R_3 + R_4} \right]$$

$$(V_0/\bar{R}) = EB(T)$$

$$dE(T) = \frac{EB(T)}{4R} (-(dR_1 + dR_3) + (dR_2 + dR_4))$$

This relation says that the temperature slope of the bridge may either be positive or negative. By our resistor name assignment, (R1, R3) make the slope negative if the sum of their slopes are the greatest; (R2, R4) make the slope positive if the sum of their slopes are greatest. Analytically,

$$\text{Slope } E(T) = \begin{cases} + \left[|(dR_1 + dR_3)| < |(dR_2 + dR_4)| \right] \\ - \left[|(dR_1 + dR_3)| > |(dR_2 + dR_4)| \right] \end{cases}$$

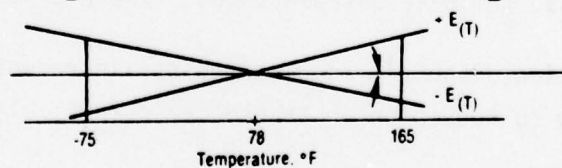

Figure A-210

17680

Zero slope adjustment, therefore, is accomplished by adjusting the slope of either R1 or R3 if E(T) slope is negative or (R2, R4) if positive. This can be done by a passive "0" T C Resistor in parallel with the selected gage as shown below.

Parallel Resistors

$$R = (R_1 R_2 / R_1 + R_2)$$

$$TCR = (R_2 / R_1 + R_2) TCR_1 + (R_1 / R_1 + R_2) TCR_2$$

$$\text{Let } TCR_1 = 0$$

$$TCR = (R_1 / R_1 + R_2) T.C. R_2$$

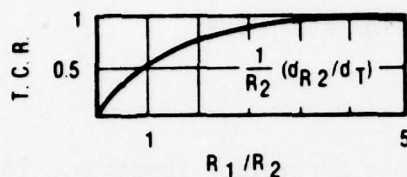

Figure A-211

17681

Qualitatively, the temperature slope of $E(T)$ must be very bad indeed to require a parallel resistor of 10 times the bridge resistance or 5,000 ohms. From the graphs of Figure A-211, it can be seen that the rate of change of slope with comp resistance is small. Therefore, a change in this value of 50 ohms (worst case for the cable) will effect the result in an unnoticeable way. A more common value for zero slope comp resistor is 25K to 50K ohms.

A-4 MECHANICAL DESIGN

Contoured Diaphragm

Approximate hand calculations using Timoshenko and Woinowsky, "Theory of Plates and Shells," pages 298 through 302, and Roark, page 250, showed that contoured diaphragms had definite disadvantages. These disadvantages are:

- (1) Thicker outside diaphragm edge caused strain reduction in outside gage leading to reduction in transducer output voltage.
- (2) Reduction in outside strain gage value caused major imbalance between inside and outside bridge response causing compensation difficulties.

Cantilevered Beam Design

Comparison - Constant Moment/Rectangular

Analysis was conducted to determine the output voltage for a constant moment versus a rectangular geometry beam (figures A-212, A-213). The output voltage was significantly lower for the constant moment beam configuration for the same length and geometric size constraints of stress gage geometry.

Celeco designed a rectangular cantilevered beam (figure A-215) to mount inside a miniature stress transducer. Analysis was conducted to evaluate the reinforcement effect of the beam on the diaphragm. Results indicated that the 0.015 in. thickness beam was adequate to minimize diaphragm reinforcement effect and maximize electrical output. Some of the supporting calculations are presented below.

Rectangular Beam

$$\sigma = MC/I, C = h/2, I = bh^3/12$$

$$\sigma = 6M/bh^2, M = W_B l, \epsilon = \sigma/E$$

$$\epsilon = 6 (W_B l / E b h^2)$$

Constant Moment

$$\sigma = h E / 2r, Vr = M/EI$$

$$\sigma = Mh/2I, I = boh^3/12$$

bo is the width of the root of the beam; bo = 2b; M = Wl

$$G = 3 (W_B l / b h^2)$$

$$\epsilon = 3 (W_B l / E b h^2)$$

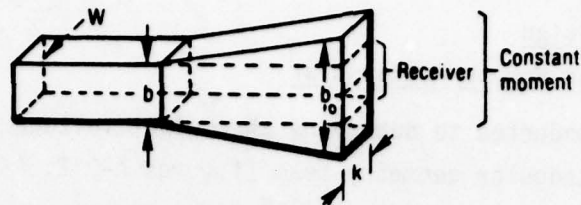

Figure A-212

17684

Rectangular Beam

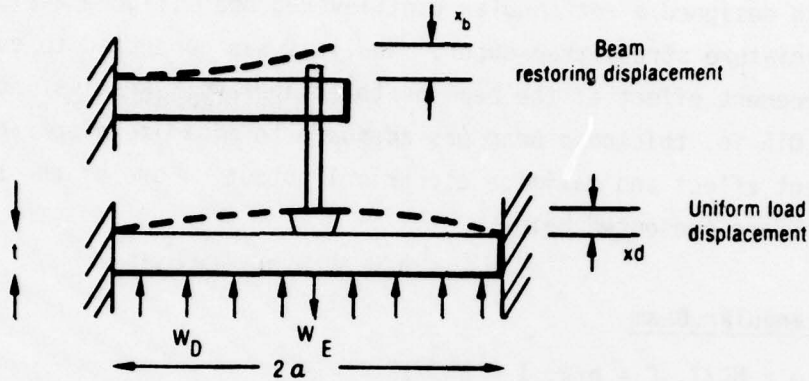

Figure A-213

17685

If the displacements are coaxial, the scalar sum will give the resultant displacement.

$$x = x_d - x_b$$

From Roark

$$\frac{W_B l^3}{3E_B I} = \frac{3W_D (M^2 - 1)a^2}{16\pi E_D M^2 t^3} - \frac{3W_B (M^2 - 1)a^2}{4\pi E_D M^2 t^3}$$

If 17-4 is used for the whole structure, then $E_b = E_d$. Solving for the force on the beam

$$W_B = \frac{\left[\frac{3W_D (M^2 - 1)a^2}{16\pi M^2 t^3} \right]}{\left[\frac{3(M^2 - 1)}{4\pi M^2 t^3} \right] + \left[\frac{l^3}{3I} \right]}$$

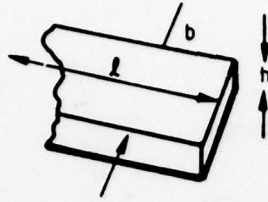

$$W_D = W \pi a^2$$

$$I = b h^3 / 12$$

Figure A-214

17686

$$W_B = \frac{3W\pi a^4 (m^2 - 1) b h^3}{12a^2 (m^2 - 1) b h^3 + 64\pi m^2 t^3 l^2}$$

For 17-4 PH in the H900 condition (see Armco Bulletin 5-6C), modulus of elasticity is 28.5×10^6 psi; Poisson's ratio is 0.272.

$$\begin{aligned} m = 1/\nu, \quad 3\pi(m^2 - 1) &= 117.9 = K1 \\ 12(m^2 - 1) &= 150.2 = K2 \\ 64(m^2)\pi &= 2,717.6 = K3 \end{aligned}$$

$$W_B = \frac{K1 \cdot W b h^3}{K2 \cdot a^2 b h^3 + K3 \cdot t^3 l^3}$$

Beam

$$\sigma = MC/I, \quad C = h/2, \quad M = W_B l, \quad I = b h^3 / 12$$

$$\sigma = 6 W_B l / b h^2, \quad \epsilon = \sigma / E$$

$$\epsilon = 6 W_B l / b h^2 E$$

Inserting W_B , redefining the constants, and $W_B = P \cdot A$

$$\left\{ \begin{array}{l} C1 = 6K1 = 705.6 \\ C2 = 28.5 \times 10^6 K3 = 4.28 \times 10^9 \\ C3 = 28.5 \times 10^6 K3 = 7.745 \times 10^{10} \end{array} \right\}$$

$$\epsilon = C1 l W a^4 h / (C2 a^2 b h^3 + C3 l^3 t^3)$$

TABLE A-53. DIAPHRAGM AND BEAM DIMENSIONS

Diaphragm			Beam		
2,000	a	0.163	Normal	l	0.200
	t	0.0265		b	0.035
500	a	0.163	Moderate	h	0.020
	t	0.0166		l	0.130
				b	0.035
			h	0.016	

Assume strain from $50\mu\epsilon$ to $500\mu\epsilon$, and solve previous equations for 2,000 psi and 500 psi.

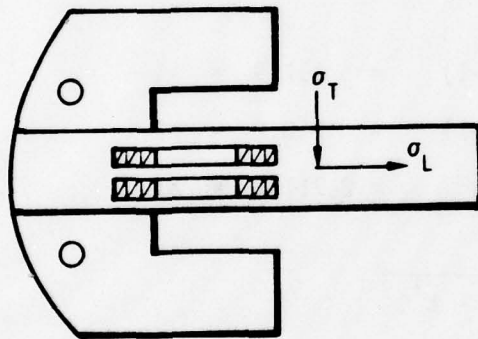

Figure A-215

17687

$$\bar{\sigma} = \int \sigma(x) dx / \int dx$$

$\sigma_T = -\mu\sigma_L$ contained in the transfer functions for constant moment and rectangular

$$\sigma_L = \frac{MC}{I}, M = Wx, C = h/2, I = bh^3/12$$

$$\bar{\sigma}_L = \sigma_W / bh^2 \cdot \int_{0.150}^{0.200} x dx / \int_{0.150}^{0.200} dx = \sigma_L \max \left[\frac{\int x dx / \int dx}{l} \right]$$

$$\left\{ \begin{array}{l} \bar{\sigma}_L = 0.875 \sigma_L \text{ max} \\ \bar{\sigma}_L = 0.950 \sigma_L \text{ max} \end{array} \right\} \quad \left\{ \begin{array}{l} \text{P01-05-500} \\ \text{P01-02-250} \end{array} \right\}$$

$$\bar{\epsilon} = \bar{\sigma}/E, \quad \epsilon_{\text{ave}} \text{ not used}$$

Bridge Output

$$e(T) = E_A(T) \sigma(T) \epsilon_{\text{max}}$$

TABLE A-54. BEAM STRAIN VS DIAPHRAGM THICKNESS

10 ⁻³ Output	10 ⁻⁶ Strain	2,000 psi Unit 10 ⁻⁶		Ambient Values
		10 ⁻³ Diaphragm t	Diaphragm Displacement	
14.7	50	50.6	66.4	EB _(T) = 2.1 V σ _(T) = 140 R _S = 1,750 ohms
29.4	100	40.2	132.4	
44.1	150	35.1	198.8	
58.8	200	31.9	264.9	17-4PH-H900
73.5	250	29.6	331.6	
88.2	300	27.8	400.3	
102.9	350	26.5	462.1	
117.6	400	25.3	531.0	
132.3	450	24.3	599.3	
147.0	500	23.5	662.7	
		500 psi Unit		
14.7	50	31.9	66.3	x _d = 4.3 x 10 ⁻¹² (P/t ³)
29.4	100	25.3	132.7	
44.1	150	22.1	199.2	
58.8	200	20.1	264.7	
73.5	250	18.6	334.1	
88.2	300	17.5	401.2	
102.9	350	16.6	470.0	
117.6	400	15.9	534.8	
132.3	450	15.3	600.3	
147.0	500	14.7	676.8	

TABLE A-55. BEAM STRAIN VS DIAPHRAGM THICKNESS

10^{-6} Strain	2,000 psi 10^{-3} Thickness, in.	500 psi 10^{-3} Thickness, in.	
50	50.62	31.89	Diaphragm, diameter 0.326 in.
100	40.18	25.30	
150	35.10	22.09	
200	31.89	20.06	
250	29.60	18.62	
300	27.85	17.51	
350	26.46	16.63	
400	25.36	15.89	
450	24.32	15.27	
500	23.48	14.74	
550	22.75	14.27	
600	22.09	13.85	
650	21.51	13.46	
700	20.50	13.15	
750	20.06	12.84	
800	19.61	12.56	
850	19.29	12.32	

Geometric Considerations for Cable Connectors

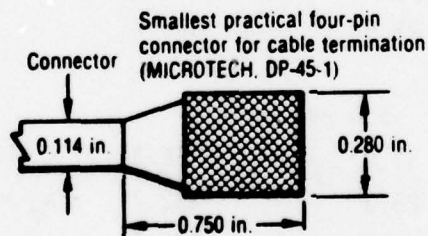

Figure A-216

17709

The 0.125-in. diameter case hole requirement eliminates a conventional hard-wired cable termination. The reason is that there is not a cable connector that small that is practical.

To accommodate such a connector, the larger hole size would be needed. Since this does not seem to be a solution the connector is eliminated.

Connector, Pin Removable

Another approach is to use a connector from which the pins can be removed. The cable would be assembled complete with connector by the manufacturer. The user would then remove the pins from the shell, install the transducer and reassemble the shell.

The mechanical restriction is illustrated in Figure A-217. The last pin and wire must fit through the 0.0625-in. space.

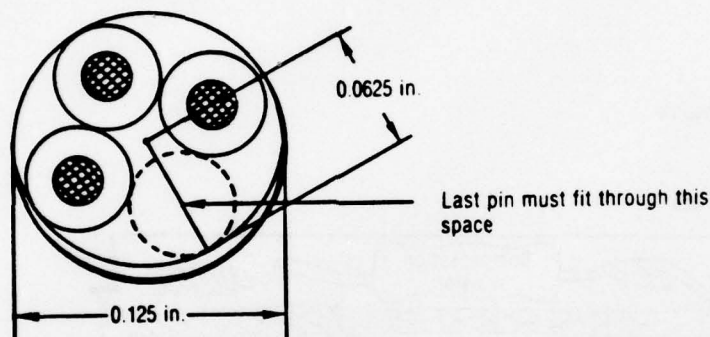

Figure A-217

17688

The skill demand, hence risk, to the user is to:

1. Be able to install the pins
2. Get the pins in the right place.

We did not find a connector with pins small enough to accommodate this method. However, there are available individual pin connectors that will work. Namely, the concord jack and pin arrangement, Figure A-218. The four wires of the cable would be fitted with the pins; the compensation module with the jack. The cable and pins would fit through the hole as shown and then be mated with compensation module. Shrink tubing would be fit over the jack and pin arrangement for insulation.

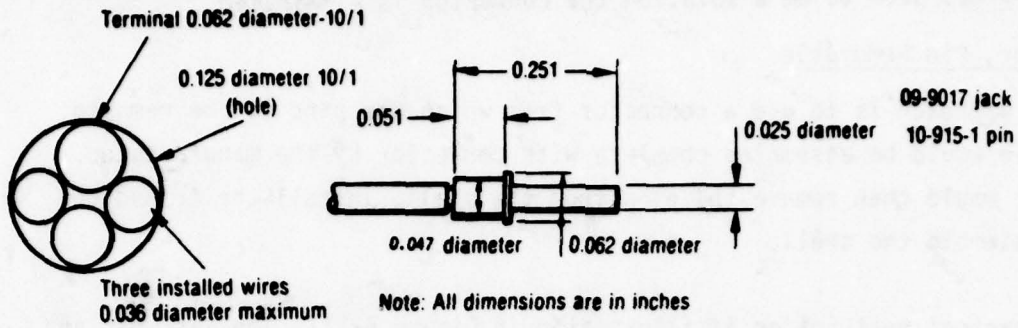

Figure A-218

17689

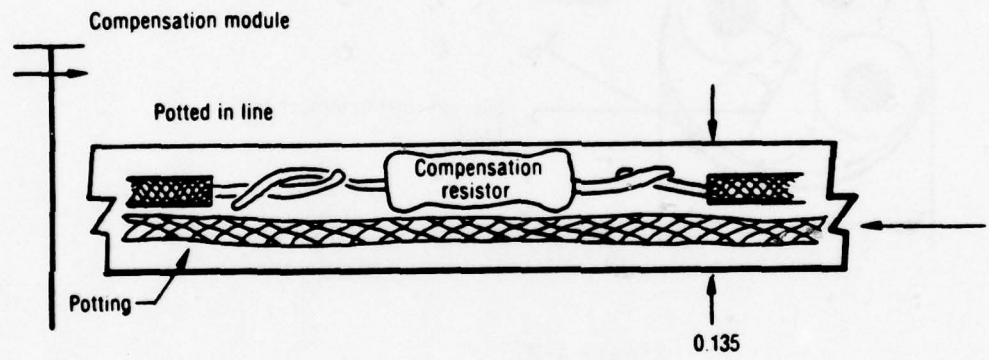

Figure A-219

17690

The zero TC resistors used for compensation are a minimum size of 0.090 in. The added 3 conductors in a tightest array give a minimum dimension of 0.126. If a 0.005 wall thickness could be maintained around this assembly, then it would be 0.135 minimum diameter.

All compensation has been eliminated from inside the transducer by the intrinsic safety requirement. It takes at least 10 V at 7 mA at the input terminals of the compensation unit to get a useable, compensated output, if stainless steel or other high resistance wire is used.

Compensation Module Considerations

A serialized module can be used with 4 external pins for connection to the transducer.

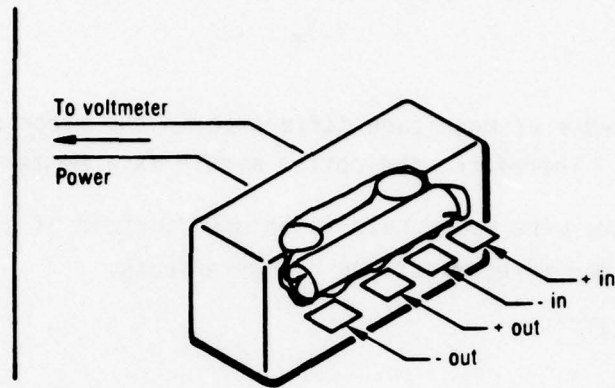

Figure A-220

17691

Coded wires and pins will have to be used so that the user can properly connect the instrument.

For completing the bridge outside

$$e_{\text{out}} = E(BT)/4\bar{R} (dr1 + dr2 + dr3 - dr4 + \Sigma dr)$$

$+ \Sigma dr$ is any change of resistance internal to the bridge. If there are six long leads with connections internal to the bridge, then there is considerable room for bridge output change. The expected magnitude is

$$e_{\text{out}/\text{ohm}} = 2.22/1,800 (1.0) = 1.23 \text{ mV/ohm.}$$

For completing the bridge internally $\pm \Sigma dr$ is eliminated and any change in bridge output will have to be through $E(BT)$, $E(BT) \Delta e_{out}$. The expected magnitude for a one ohm change in R_s is

$$E(BT)/\text{ohm}/1,800 = 10\,450/2,000 - [450/1,999] = 0.1 \text{ mV}/\Omega$$

$$\Delta E/EBT = 0.05\%/\text{ohm}$$

There is an additional order of magnitude difference in the error signal between the two methods. Therefore, the potted module is a better approach.

In any case low resistance wire would have to be used instead of stainless steel wire to minimize lead wire resistance change effects.

A-5 CHEMICAL COMPATIBILITY

Body

There does not seem to be any information on the corrosive effects of solid propellants on metals. CSD has supplied a list of propellants with a most probable corrosive for each. Since this is only qualitative information only qualitative answers can be given. Even worse, the only answers we know of depend on exposure to aqueous solutions. There is no doubt that such exposure is orders of magnitude worse than a propellant environment. However, that is all we have.

Since chemical activity increases with increasing temperature, worse case will be at the highest temperature or 165°F.

Oxides

All of the oxides mentioned are harmless to stainless steel at 165°F. In fact, a process termed passivation is used on these metals (1) to eliminate elemental iron on the surface and (2) to increase the oxide thickness and to make them less corrodable. The usual solution is:

500 ml	HNO ₃
500 ml	deionized water
20 gr	K ₂ Cr ₂ O ₇ (or N ₂ CR ₂ O ₇).

The parts are soaked at 140°F to 160°F for 30 min in this solution.

Halogens

Hydrochloric and hydrofluoric acid in aqueous solution attack all precipitation hardened stainless steels, all 300 stainless (316 slowly) and all 400 stainless steels.

Halogen-nitric solutions attack all stainless rapidly. For example, a descaling solution after heat treatment for most stainless steels is a 25% by volume (concentrated nitric acid), 6% by volume (concentrated) hydrofluoric acid, and remainder D.I water. The solution is used at room temperature for a maximum of 10 min. If the parts are exposed for more than 10 min, the smeared out shiny surface due to mechanical finishing (amorphous) will be dissolved. From this point the etch rate decreases by an order of magnitude but does continue.

Sulphides

The only reference we have to sulphide corrosion is the Shell Oil Company "Sour Gas Well" test specification. The parts are to be immersed in an aqueous solution of 5% sodium chloride saturated with hydrogen sulphide at room temperature. This solution attacks all stainless steels tested; most vigorously at weld joints or weld spots. The longest lived was 316. It lasted 30 days; 17-4 corroded at welds in a matter of hours.

Even in view of these gloomy effects, the history of stress transducers does not indicate any corrosion problem within orders of magnitude of those cited. Thiokol did indicate a problem with corrosion of the case material, but they were testing as high as 300°F where the chemical activity would be about 250 times greater than the activity at 165°F.

Based on the history we would recommend 17-7, 17-4, 15-5 or 13-8 PH stainless steels as case material. The heat treatment is well known and the results of mechanical stability are known. We are not so confident with other materials.

TABLE A-56. PROPELLANT CORROSIVE POSSIBILITIES

Types of Propellant	Corrosive Products
PBAN	HCL Acrylic acid Perchloric and HCL
CT	HCL
Double Base	Oxide of N, NO ₂ - nitric acid
Polysulfide	N ₂ S
Energetic Plasticizers	NF, NF, NO ₂
Burning rate catalysts	Cu ₂ O ₂ , catalyst (NH ₄) ₂ Cr ₂ O ₇ Long time basis - HCL, N ₃ O ₃
Additives	

Cable

The cable study has shown that cable resistance cannot exceed the bridge impedance. This restricts the cable material to around 4.0 ohms/ft max. The leading candidates seem to be Monel, gold, platinum.

The chemical compatibility of Monel with any environment is illustrated by a quote from the International Nickel Companies Monel Information Pamphlet. "In general, (Monel) is more corrosion-resistant than either of its constituents (nickel) (copper)." Along with this is a list of the compounds formed by each, most readily.

Based on using internal compensation resistors, the monel wire appears to be the best material for chemical corrosive resistance and low electrical resistance per foot. Monel wire was available at local Los Angeles suppliers in 500 to 1,000 foot quantities.

Seals and Electrical Outlets

Metal seals have previously been obtained using epoxy and other adhesives. These conventional seals have limited chemical resistance and are not considered adequate moisture seals for long time applications. A number of earlier stress gage applications have experienced large electrical instability which may have been attributed to chemical corrosion. This corrosion may have penetrated the transducer through the metal-adhesive-metal seal. Because of this poor application history and the large variety of potential propellant corrosive products, it was recommended that all seals be metal-to-metal using electron beam welding and that lead wires be brought out of the transducer body with glass-to-metal headers.

In order to ensure the long range survivability and dependability of these embedded stress transducers, both the external seals and internal connections would be metal-to-metal without use of adhesives except for bonding the semiconductor strain gages.

APPENDIX B - CELESCO TRANSDUCER COMPENSATION

METHODS AND PROCEDURES FOR
COMPENSATING SEMICONDUCTOR
STRAIN GAGE TRANSDUCERS

SCOPE:

This is a general presentation of the requirements for compensation of a silicon strain gage 4 active element bridge. The presentation is made in 3 sections: (1) Development of the bridge relations; (2) definition of variables; and (3) summary and procedure for compensation.

1. Development of Bridge Relations

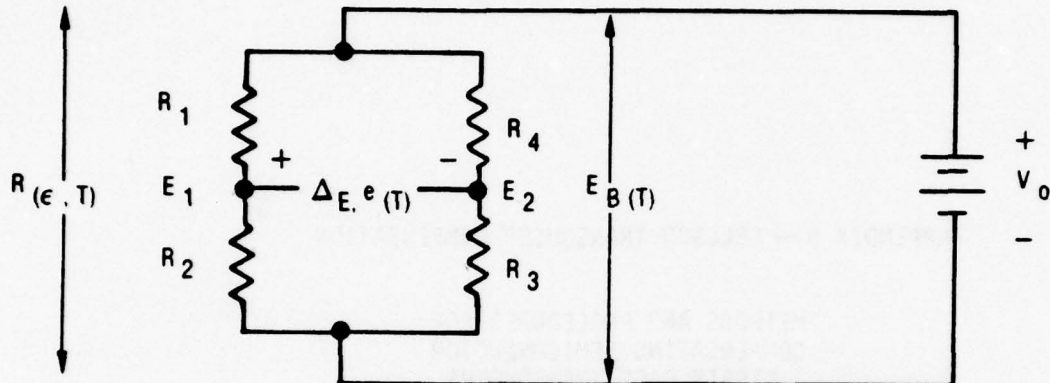

Figure B-221

17702

Static Relations

E1, E2

$$E1 = V_0 [R2 / (R1 + R2)]$$

$$E2 = V_0 [R3 / (R3 + R4)]$$

ΔE

$$\Delta E = (E1 - E2)$$

$$\Delta E = V_0 [R2 / (R1 + R2) - R3 / (R3 + R4)]$$

Balance

$$\text{SET } \Delta E = 0$$

$$R1 / R2 = R3 / R4$$

Trivial

$$R_1 = R_2 = R_3 = R_4$$

Span

Adjust V_0 for magnitude of ΔE required, since $\Delta E \propto V_0$.

Dynamic Relations

Bridge Output

Take the derivative of ΔE .

$$d(\Delta E) = V_0 (\partial \Delta E / \partial R_1) dR_1 + (\delta \Delta E / \delta R_2) dR_2 + (\delta \Delta E / \delta R_3) dR_3 + (\delta \Delta E / \delta R_4) dR_4$$

$$d(\Delta E) = V_0/4 (-dR_1/R_1) + (dR_2/R_2) + (-dR_3/R_3) + (dR_4/R_4)$$

Let R_1 and R_3 be compression gages and R_2 and R_4 be tension gages and impose the restriction that $R_1 \approx R_2 \approx R_3 \approx R_4$.

$$\text{Then, } D(\Delta E) = e(T) = V_0 G(T) \epsilon(T)$$

$$\text{Where } dR/R = G\epsilon$$

Linearity

Gage factor for semiconductor strain gages is parabolic with strain. However, if used in conjugate pairs the nonlinear terms add out at the summing points (E_1, E_2) of the circuit.

$$dR/R = A_0\epsilon + A_2\epsilon^4$$

Substituting this relation in the bridge output formula gives

$$e(t) = (V_0/4) -(A_0 \epsilon_1 + A_2 \epsilon_1^4) + (A_0 \epsilon_2 + A_2 \epsilon_2^4) \\ -(A_0 \epsilon_3 + A_2 \epsilon_3^4) + (A_0 \epsilon_4 + A_2 \epsilon_4^4)$$

Remembering that,

$$\epsilon_1, \epsilon_3 = - \text{ forces}$$

$$\epsilon_2, \epsilon_4 = + \text{ forces}$$

The even order terms will all be positive while the odd order will take the sign of the force

$$e(T) = V_0/4 \quad A_0 \epsilon_1 + A_0 \epsilon_2 + A_0 \epsilon_3 + A_0 \epsilon_4$$

Define $A_0 = G(T)$ and impose

$$\epsilon_1 = \epsilon_2 = \epsilon_3 = \epsilon_4$$

$$e(T) = V_0 G(T) \epsilon(T)$$

The restriction of the strains being equal is realized exactly by using a constant moment beam, and to a better approximation than error requirement on a small rectangular beam.

The bridge output is seen to be directly proportional to the first order of the strain.

Compensation Requirements

Sensitivity Slope

Rewrite the bridge output so that it is given in terms of bridge voltage $EB(T)$.

$$e(T) = EB(T)G(T)\epsilon(T)$$

$\epsilon(T)$ can be shown to be a constant under particular conditions of design. The proof is omitted here in the interest of brevity, since it involves the characteristics of the steels and silicon chosen for the particular design. Suffice to say that this has been done and $\epsilon(T)$ will be taken as a constant. Then, take the derivative of $e(T)$.

$$\ln e(T) = \ln EB(T) + \ln G(T) + \ln \epsilon(T)$$

$$de(T)/e(T) = dEB(T)/EB(T) + dG(T)/G(T)$$

Now set $de(T)/e(T) = 0$.

$$-dEB(T)/EB(T) = dG(T)/G(T).$$

The requirement is that the negative percentage change of the bridge voltage be made equal to the percentage change of gage factor for the selected gages.

Passive sensitivity compensation for a temperature range ΔT is accomplished by: (1) Selecting the proper strain gage - steel combination; then (2a) for constant voltage by adjusting the bridge impedance temperature slope with a series resistor or (2b) for constant current by adjusting the bridge impedance temperature slope with a parallel resistor. This is equivalent to linearizing the $(E + dE)$ curve in Figure B-222.

Zero Slope

Rewrite the derivative of $d(\Delta E)$, with the restriction that

$$R1 \approx R2 \approx R3 \approx R4 = \bar{R}.$$

$$d(\Delta E) = (V_o/\bar{R}) (-dR1 + dR2 - dR3 + dR4)$$

$$\text{Set } d(\Delta E) = 0$$

$$(dR1 + dR3) = (dR2 + dR4).$$

Verbally, the requirement is that the sum of the slope of the compression gages must be equal to the sum of the slopes of the tension gages.

Now, since $d(\Delta E) = dE = e(T)$, then $e(T) \propto [-(dR1+dR3) = (dR2+dR4)]$, and if $|-(dR1+dR3)| > (dR2 + dR4)$, $e(T)$ will have a negative slope; if $|(dR2 + dR4)| > |-(dR1 + dR3)|$, $e(T)$ will have a positive slope. Therefore, the line E of figure B-222 can be rotated clockwise to horizontal by decreasing the sum $(dR2 + dR4)$ or counter clockwise to horizontal by decreasing the sum $(dR1 + dR3)$.

This can be accomplished for either constant voltage or constant current by adding a resistor in series with the bridge arms inside the bridge or by adding a parallel resistor across (R1, R3) or (R2, R4) outside the bridge. See Figure B-223.

Whatever the choice, changing the slope of the bridge by adjusting one of the elements affects the sensitivity compensation and so an iteration is necessary to complete calibration of bridge slopes.

Zero Balance

Zero balance is accomplished either by adding a resistor to the bridge inside the loop to force the function

$$R1/R2 + \Delta R = R4/R3$$

(see Figure B-223) or by adjusting the amplifier reference point.

Span

Span is adjusted by changing either IB or EB in a scalar way.

Definition of Variables

Silicon strain gages are completely characterized by their gage factor and their unstrained resistance. Both variables must be known as a function of temperature over the region of interest. If this information is available, then the gage after attachment to a force collector can be defined analytically. The resistance $R(\epsilon, T)$ of the attached gage is given by

$$R(\epsilon, T) = R(o, T) + R(o, T) G(T)\Delta\alpha(T) \Delta T$$

Where

$R(o, T)$ is the unstrained resistance as a function of temperature.

$G(T)$ is the gage factor as a function of temperature.

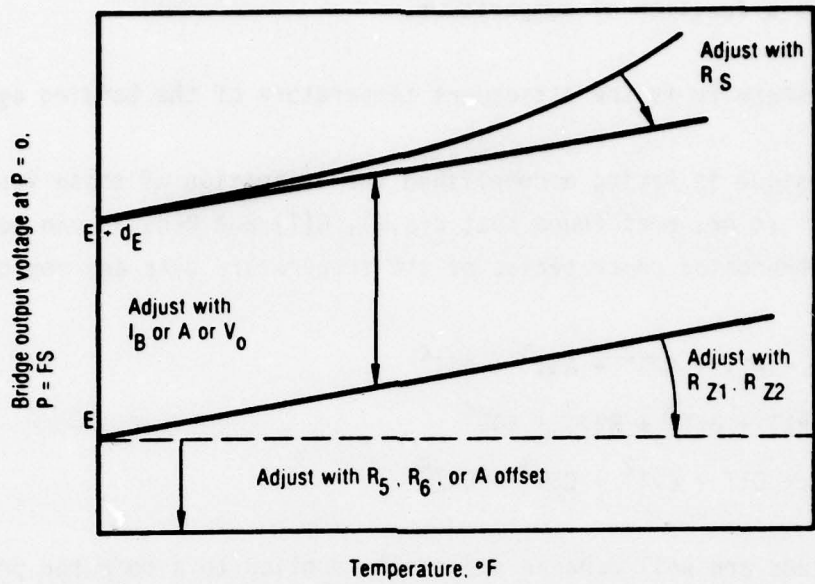

Figure B-222

17700

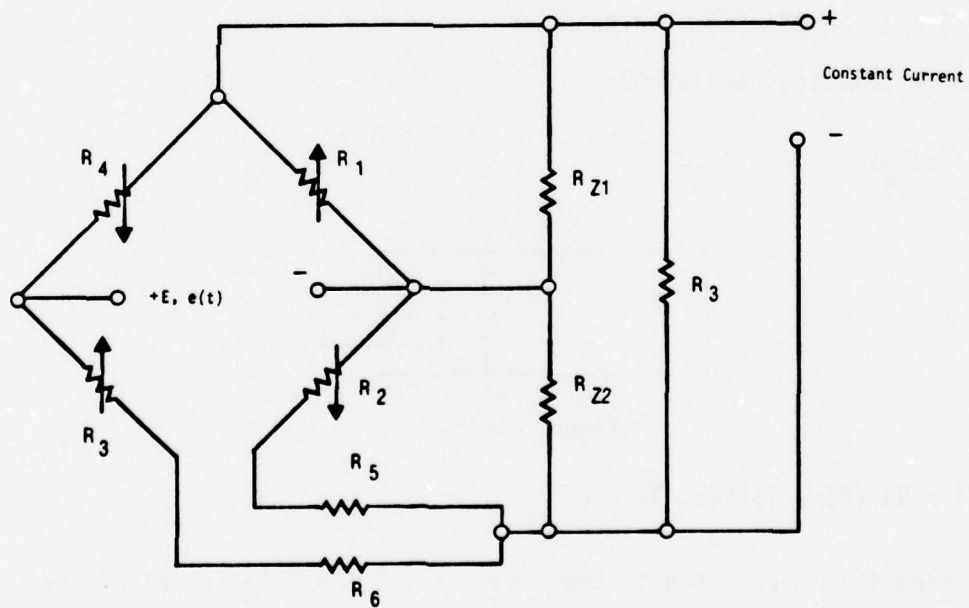

Figure B-223

17701

$\Delta\alpha(T)$ is the differential of the coefficient of expansion of the steel and the silicon as a function of temperature.

$\Delta T = (T - T_0)$ where T_0 is the attachment temperature of the bonding agent.

CeleSCO is unique in having accomplished the definition of these functions for strain gages. It has been found that $R(\sigma, T)$, $G(T)$ and $R(\epsilon, T)$ can be represented by a truncated power series of the temperature over any region of interest, as,

$$R(\sigma, T) = A_0 + A_1T + A_2T^2 + A_3T^3 + A_4T^4$$

$$G(T) = B_0 + B_1T + B_2T^2 + B_3T^3 + B_4T^4$$

$$R(\epsilon, T) = C_0 + C_1T + C_2T^2 + C_3T^3 + C_4T^4$$

These functions are well behaved and easily applied to a computer program. Hence, the solution of

$$\left\{ \begin{array}{l} e(T) = EB(T) \cdot G(T) \cdot \epsilon(T), V = k \\ e(T) = IB \cdot RB \cdot GT \cdot \epsilon(T), I = k \end{array} \right\}$$

become practical and simple.

Constant Voltage

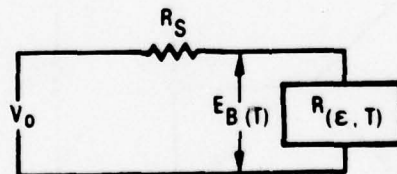

Figure B-224

17703

$$EB(T) = V_0 (R(\epsilon, T) / (R(\epsilon, T) + R_S))$$

Inserting this expression in the constant voltage relation allows error analysis and the proper selection of components before hardware is made.

Constant Current

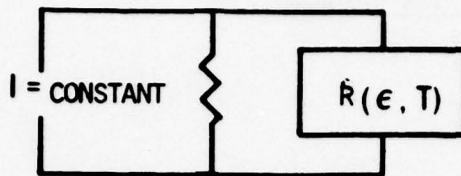

Figure B-225

17704

$$R_B = (R(\epsilon, T) R_S / R(\epsilon, T) + R_S)$$

Inserting this expression in the constant current relation allows error analysis and component selection for this case.

Compensation Procedure Flow Diagram

Procedure logic

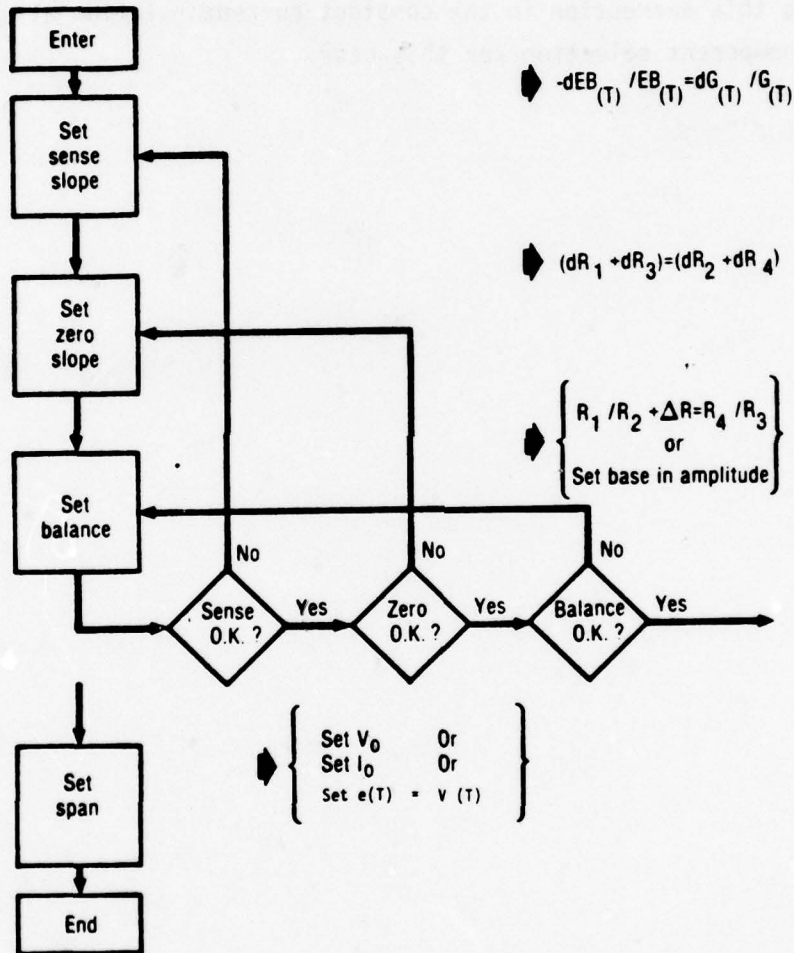

Figure B-226

17705

APPENDIX C
CELESCO PROTOTYPE TRANSDUCER DRAWINGS

ILLUSTRATIONS

Figure		Page
C-227	Transducer Diaphragm, Flat	C-325
C-228	Transducer Diaphragm	C-326
C-229	Diaphragm Subassembly	C-327
C-230	Preliminary Assembly Drawing	C-328
C-231	Header Assembly	C-329
C-232	Insulator, Diaphragm Header Cable	C-330
C-233	Solder Tab	C-331
C-234	Adapter, Test Tooling	C-332
C-235	Strain Sensor	C-333
C-236	Beam and Pivot Assembly	C-334
C-237	Pivot Tube	C-335
C-238	Force Rod	C-336
C-239	Pressure Test Fixture	C-337
C-240	Beam	C-338
C-241	Terminal Feed-Through	C-339
C-242	Charge	C-340
C-243	Force Rod Welding Fixture	C-341
C-244	Diaphragm Transducer	C-342
C-245	Diaphragm Transducer, Flat	C-343
C-246	Beam and Gage Subassembly	C-344
C-247	Diaphragm Subassembly	C-345

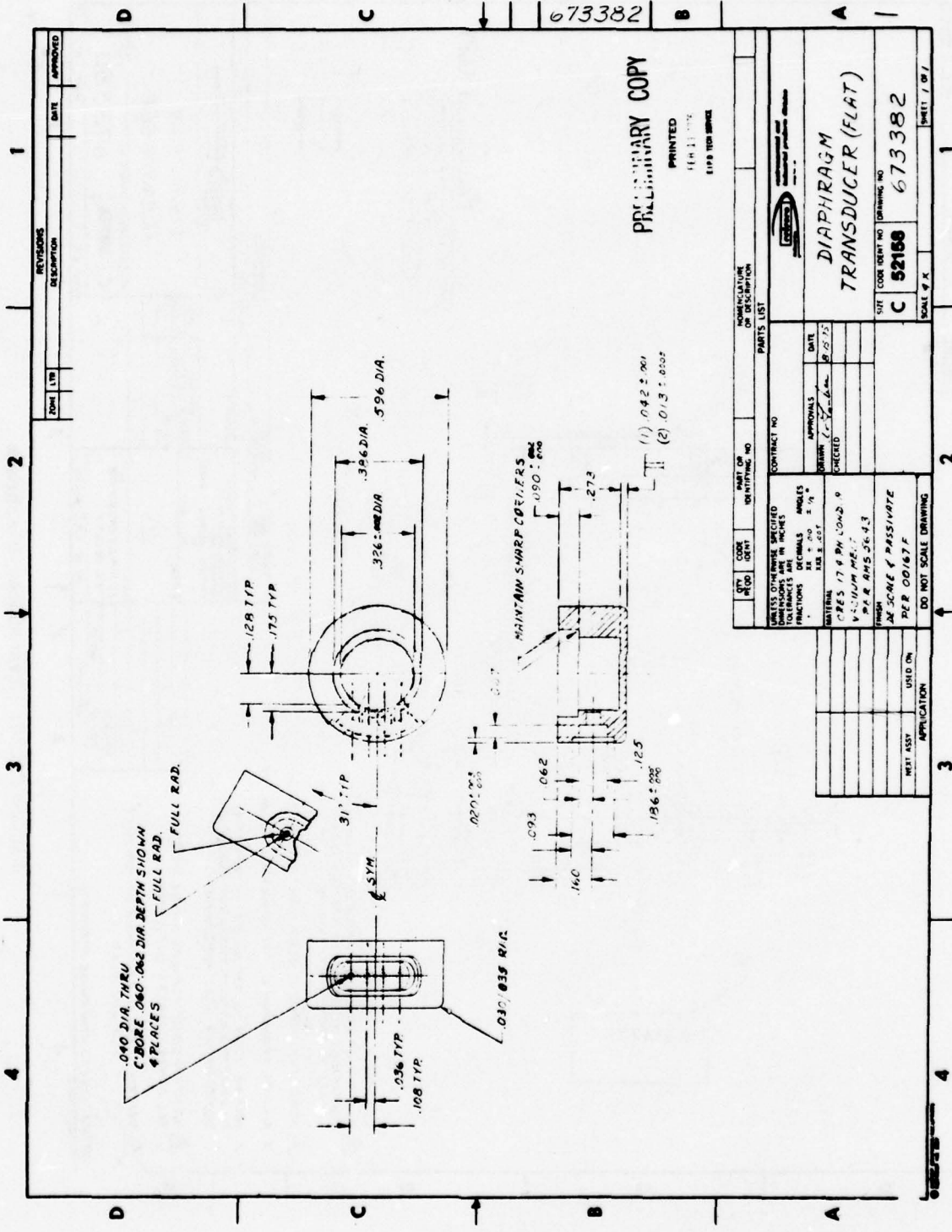
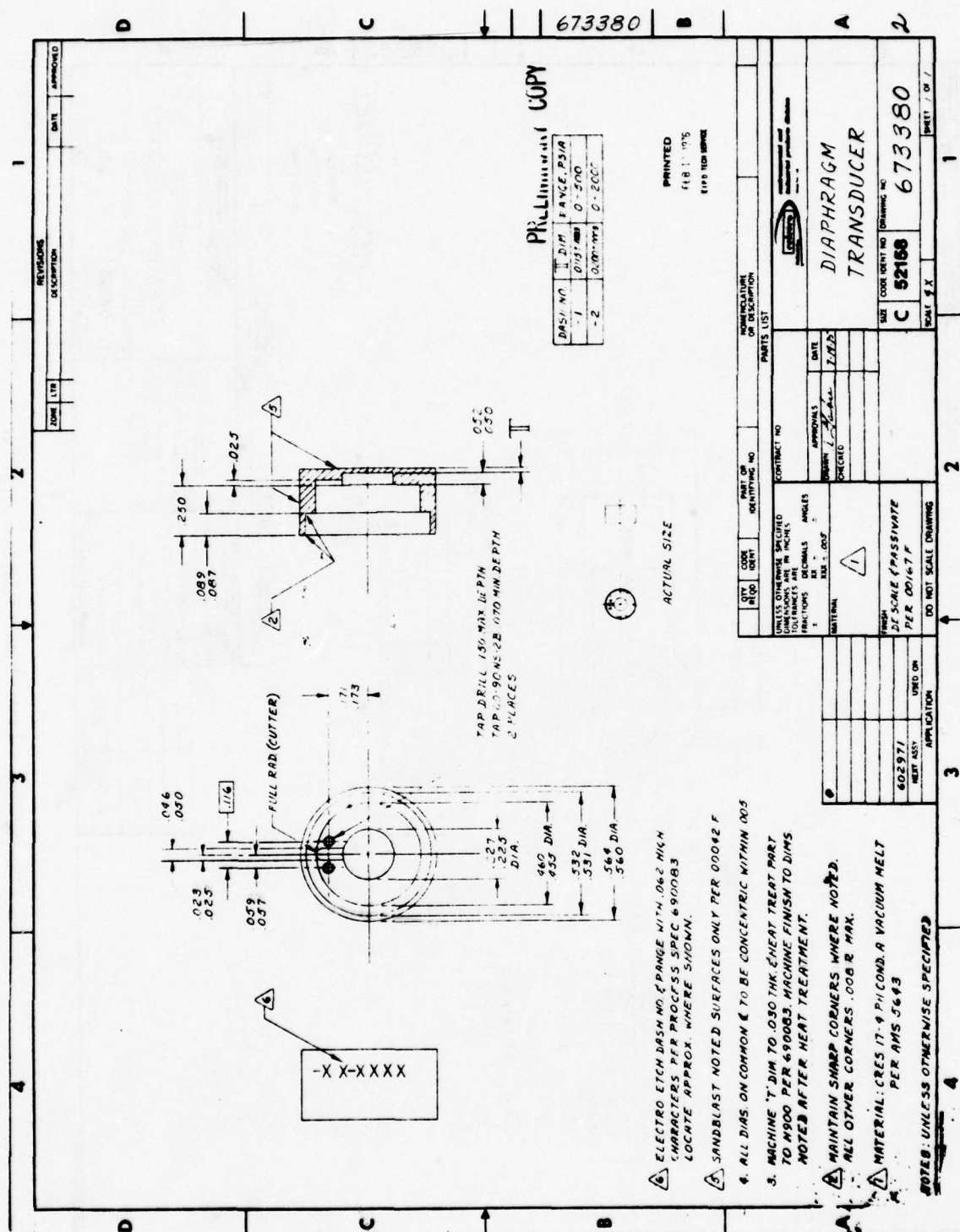

Figure 227. Transducer Diaphragm, Flat

THIS PAGE IS BEST QUALITY PRACTICABLE FROM COPY FURNISHED TO DDC

C-325



PERMANENT COPY

DASH NO	DIM	RANGE, PS/A
-1	0.151-0.00	0-2000
-2	0.201-0.00	0-2000

- 1. ELECTRO ETCH DASH NO. 1 RANGE WITH 0.02 MICR CHARACTERS PER PROCS SPEC 6900B3 LOCATE APPROX. WHERE SHOWN.
- 2. SANDBLAST NOTED SURFACES ONLY PER 00042 F
- 3. ALL DIAS ON COMMON 6 TO BE CONCENTRIC WITHIN 0.05
- 4. MACHINE "T" DIA TO .030 THK & HEAT TREAT PARY TO M900 PER 6900B3. MACHINE FINISH TO DIMS NOTED AFTER HEAT TREATMENT.
- 5. MAINTAIN SHARP CORNERS WHERE NOTED. ALL OTHER CORNERS .008 R MAX.
- 6. MATERIAL: CRES 17-4 PH COND. A VACUUM MELT PER AMS J643

NOTES: UNLESS OTHERWISE SPECIFIED

REV	DATE	DESCRIPTION

UNLESS OTHERWISE SPECIFIED DIMENSIONS ARE IN INCHES FRACTIONS OR DECIMALS IN INCHES	DATE
MATERIAL	APPROVALS
FINISH	DESIGNED
DRY SCALE (PASSIVATE PER 00167 F)	CHECKED
DO NOT SCALE DRAWING	DATE

CONTRACT NO	QUANTITY	PARTS LIST

SIZE	CODE	REV NO	DRAWING NO
C	52168		673380
SCALE	1/2 X	SHEET	1 OF 1

Figure C-228. Transducer Diaphragm

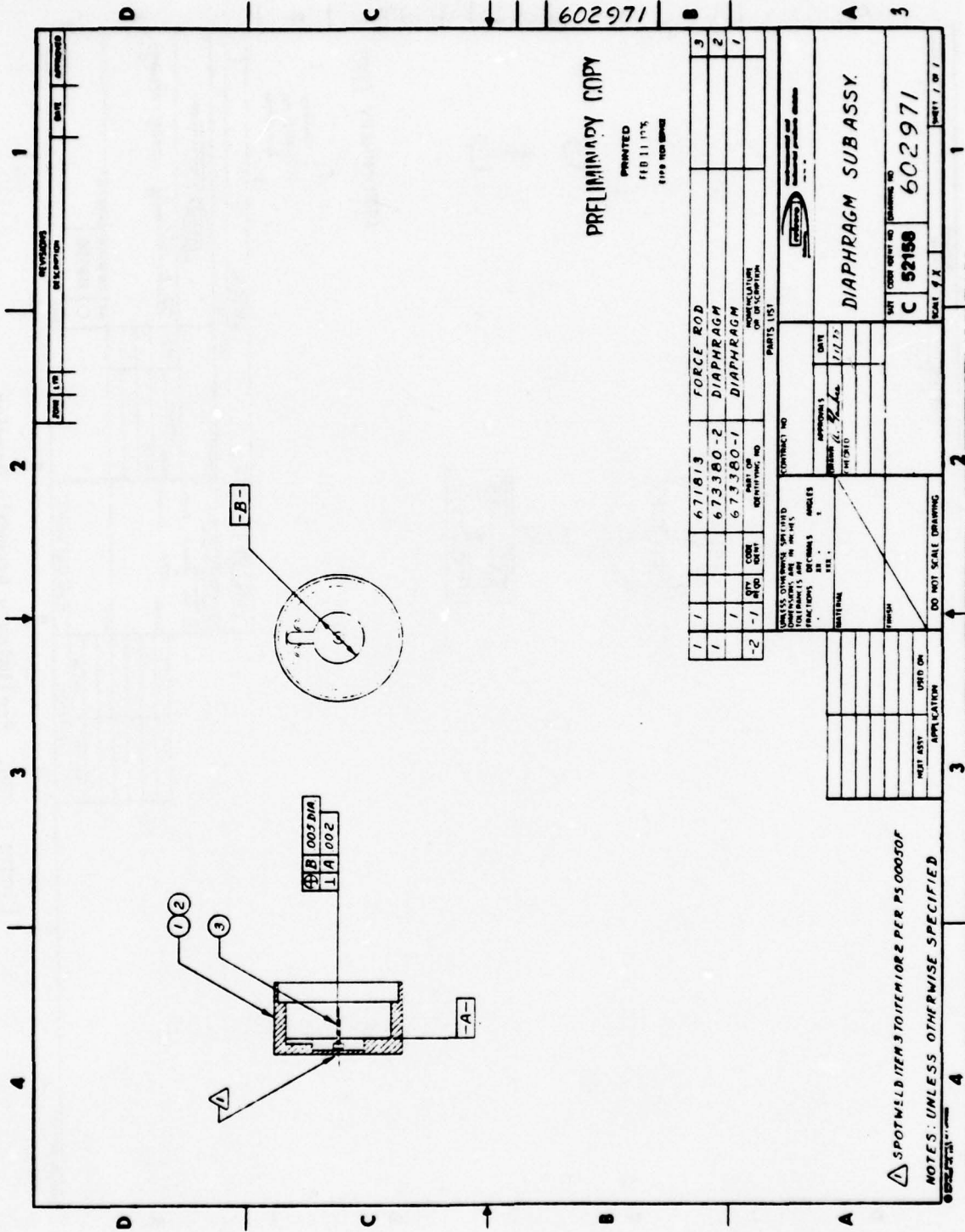

Figure C-229. Diaphragm Subassembly

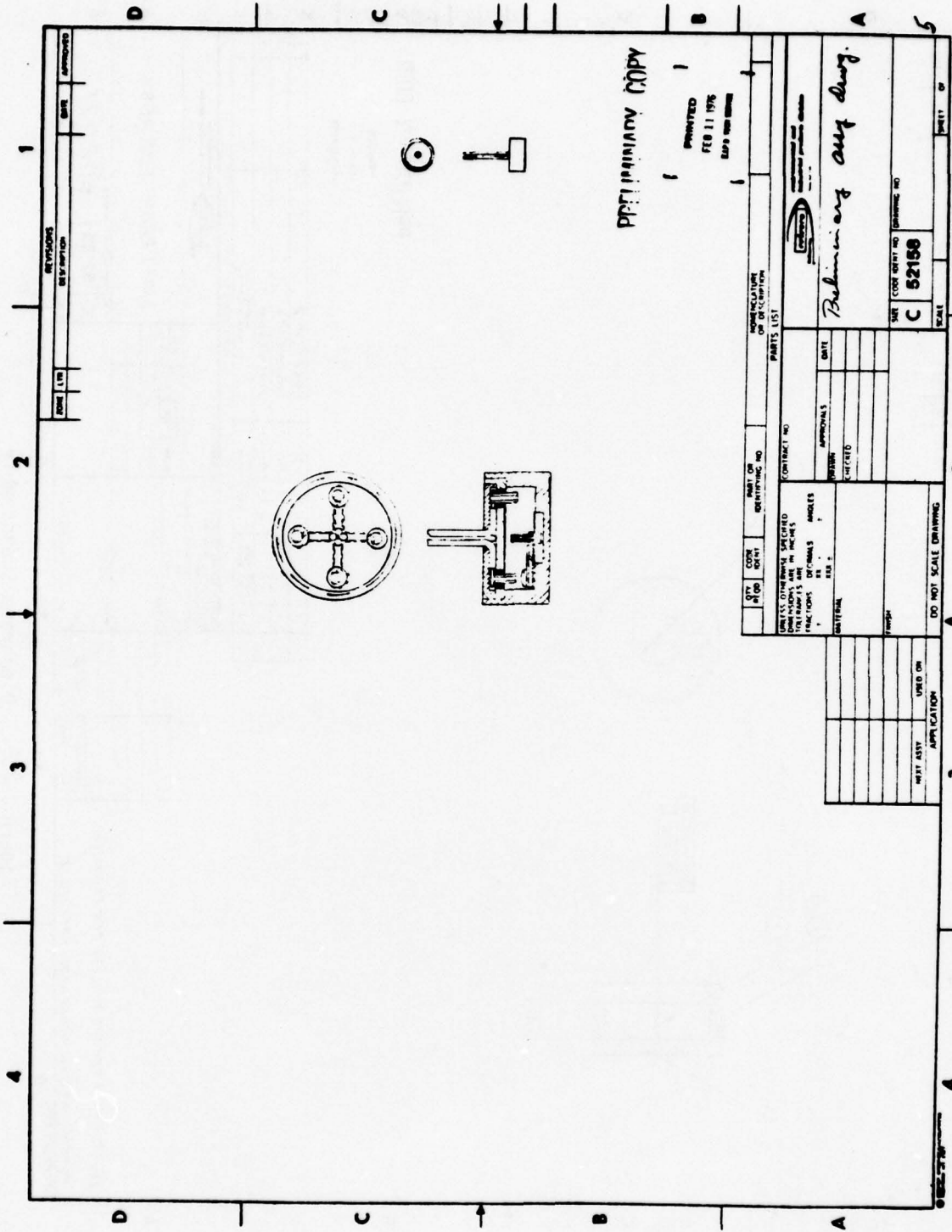
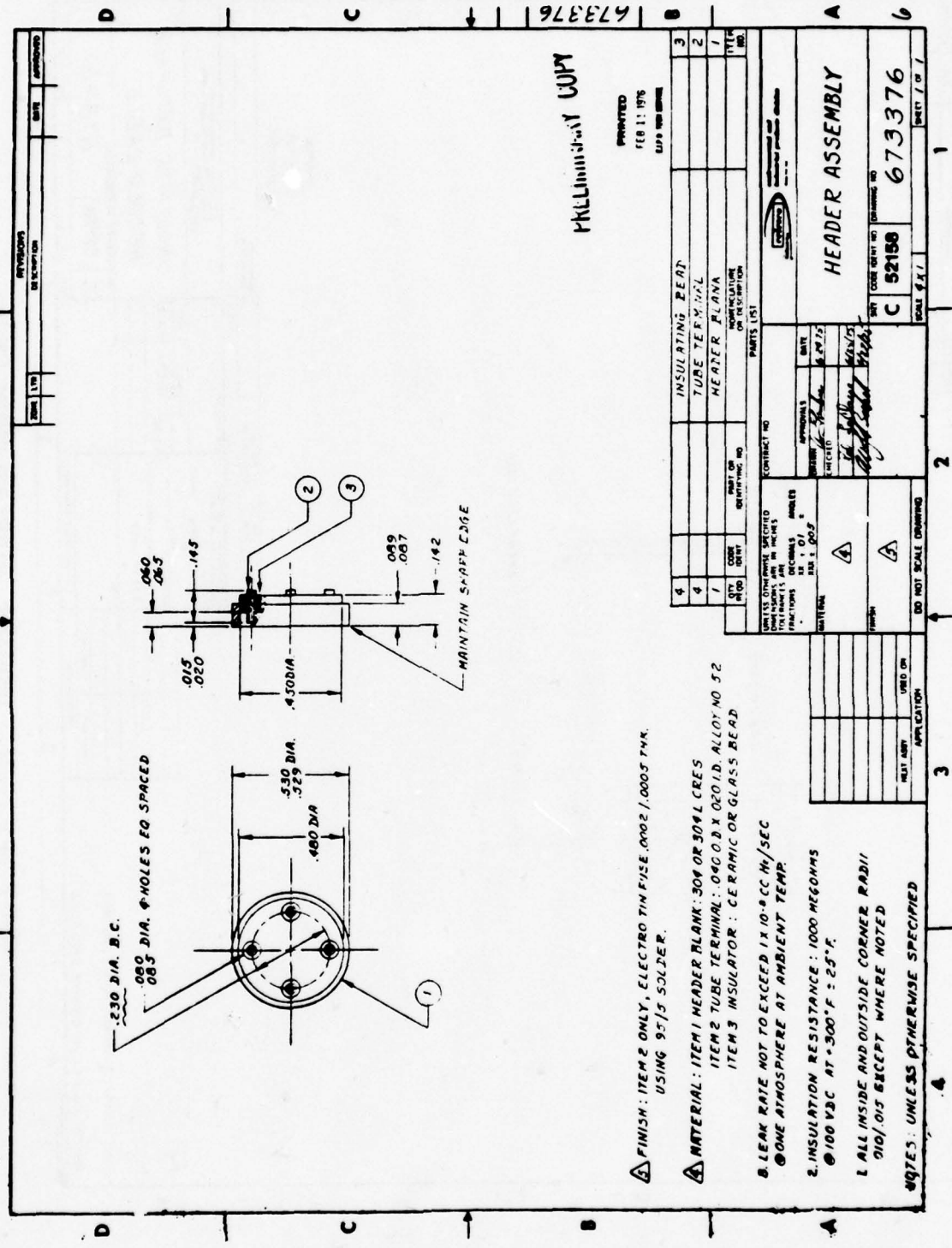

Figure C-230. Preliminary Assembly Drawing



PRELIMINARY COPY

PRINTED
FEB 11 1976
1339 1000000

ITEM NO.	DESCRIPTION	QUANTITY	UNIT
1	INSULATING BEAD		
2	TUBE TERMINAL		
3	HEADER PLANA		
4	INSULATING BEAD		

DATE	BY	APPROVED
12/1/75	J. J. ...	J. J. ...

CONTRACT NO.	
PROJECT	
CITY	
STATE	
COUNTRY	

CONTRACT NO.	
PROJECT	
CITY	
STATE	
COUNTRY	

HEADER ASSEMBLY

C 52198 673376

SCALE 2 X 1

SHEET 1 OF 1

FINISH: ITEM 2 ONLY, ELECTRO TIN FINISH .0002 / .0005 THK. USING 95/5 SOLDER.

MATERIAL: ITEM 1 HEADER BLANK: 304 OR 304L CRES
ITEM 2 TUBE TERMINAL: .040 O.D. X .020 I.D. ALLOY NO 52
ITEM 3 INSULATOR: CERAMIC OR GLASS BEAD

BLEAK RATE: NOT TO EXCEED 1 X 10⁻⁸ CC H₂/SEC
① ONE ATMOSPHERE AT AMBIENT TEMP.

INSULATION RESISTANCE: 1000 MEGOHMS
② 100 VDC AT +300°F ± 25°F.

ALL INSIDE AND OUTSIDE CORNER RADI
③ .010/.015 EXCEPT WHERE NOTED

NOTES: UNLESS OTHERWISE SPECIFIED

Figure C-231. Header Assembly

673381

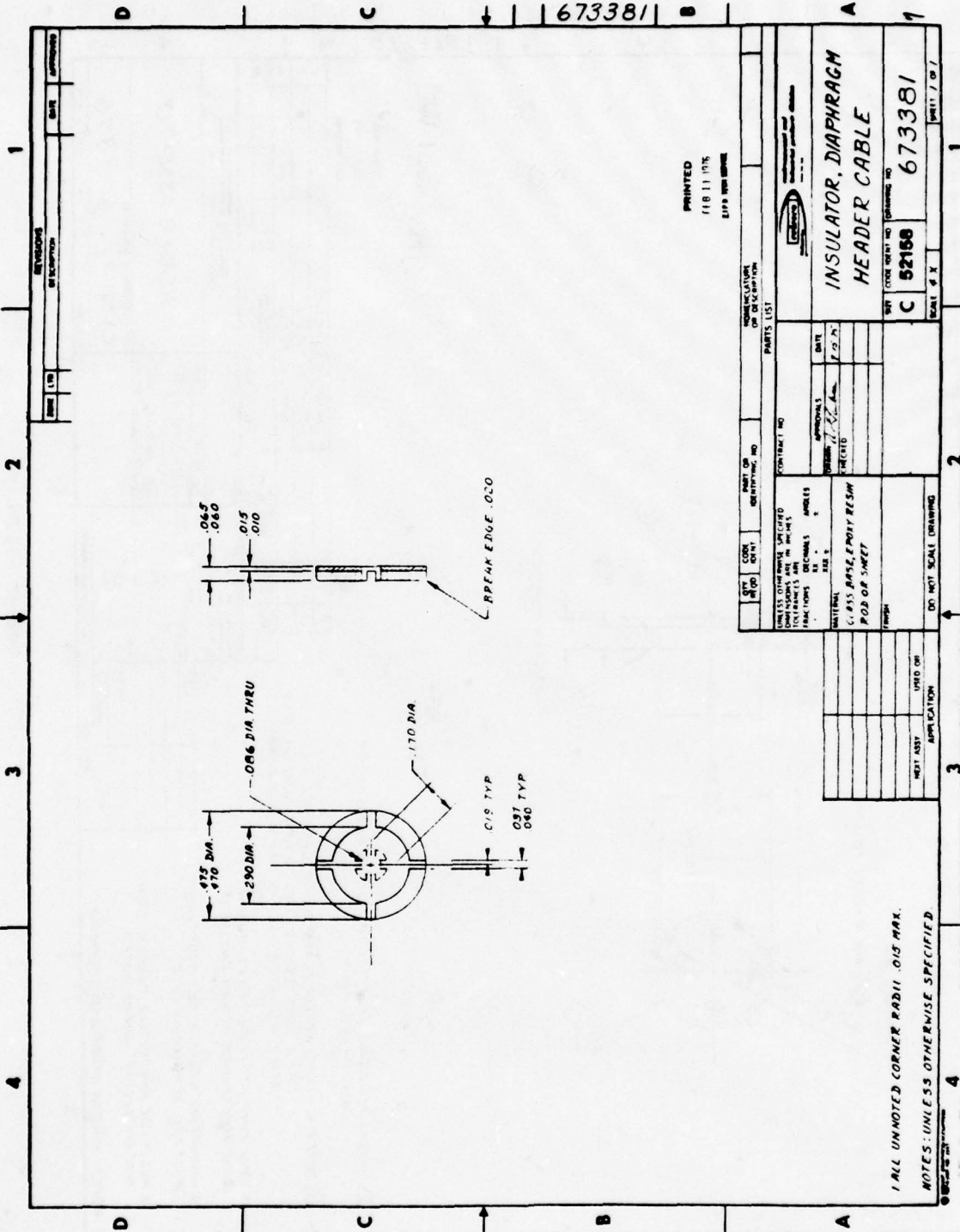

C-330

Figure C-232. Insulator, Diaphragm Header Cable

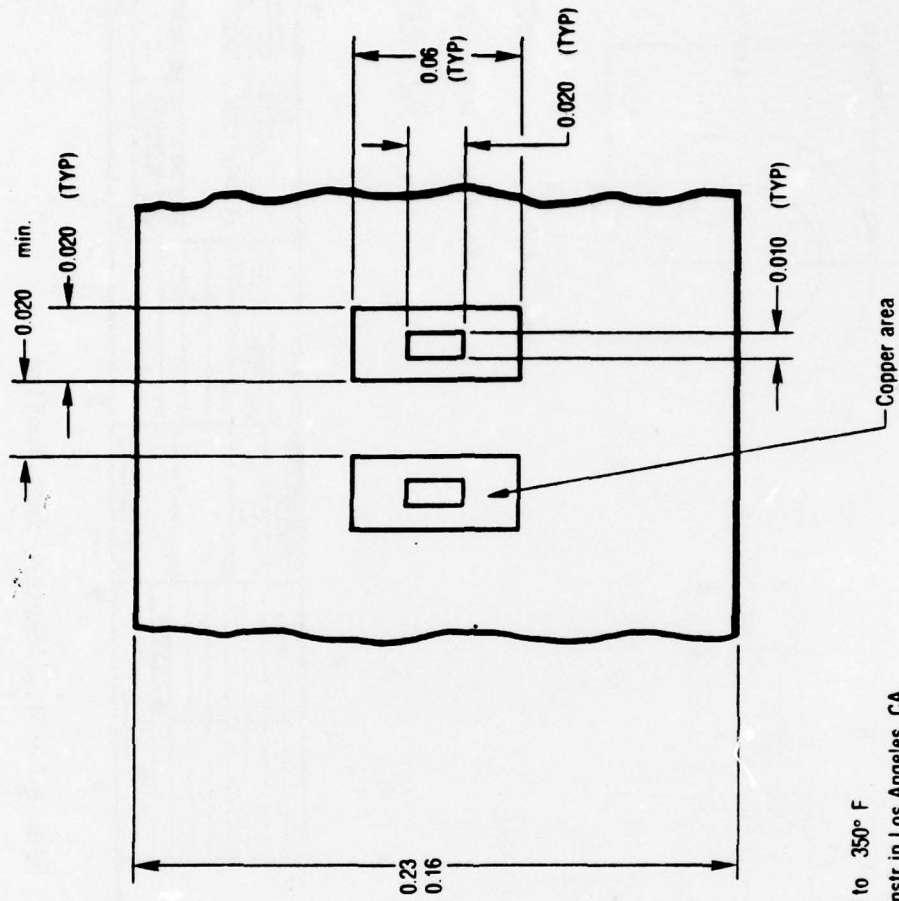

Notes:

Rated temperature range is - 65° F to 350° F

May be purchased from BVDD Co Instr in Los Angeles, CA

Material 0.0010 to -0.0018 thick copper ONA.

0.002 to -0.007 thick glass case epoxy resin backing

Letters are quality control symbols

Figure C-233. Solder Tab

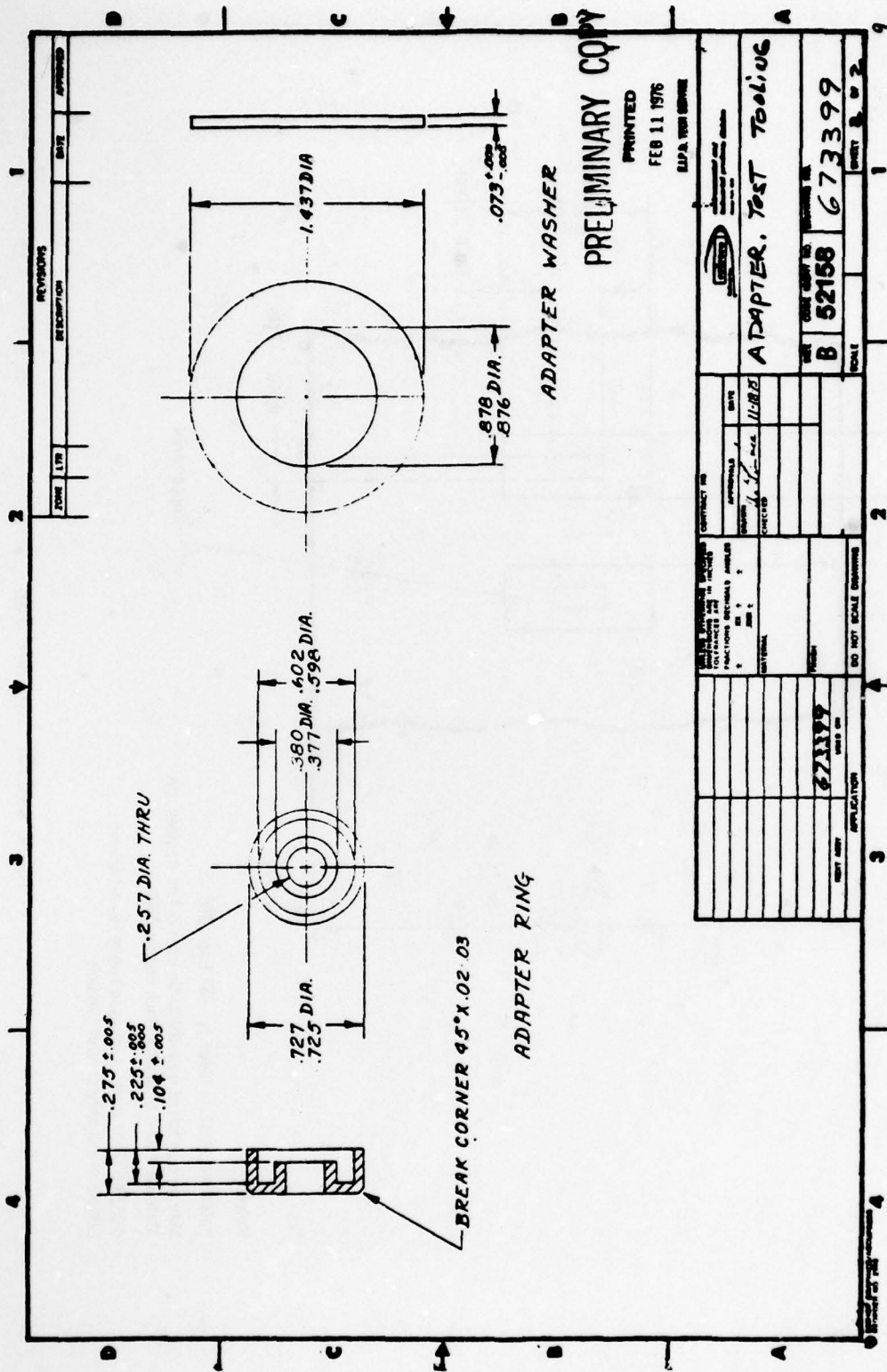

ADAPTER WASHER

PRELIMINARY COPY

PRINTED
FEB 11 1976
E.D.A. TECH SERVICE

ADAPTER, Test Tooling

THE CASE COPY IS KEPT IN THE
B 52158 673399

APPROVED	DATE	APPROVED	DATE
DESIGNED	DATE	DESIGNED	DATE
CHECKED	DATE	CHECKED	DATE
CONTRACT NO.	DATE	CONTRACT NO.	DATE
PROJECT NO.	DATE	PROJECT NO.	DATE
APPLICATOR	DATE	APPLICATOR	DATE
671199			
DO NOT SCALE DIMENSIONS			

Figure C-234. Adapter, Test Tooling

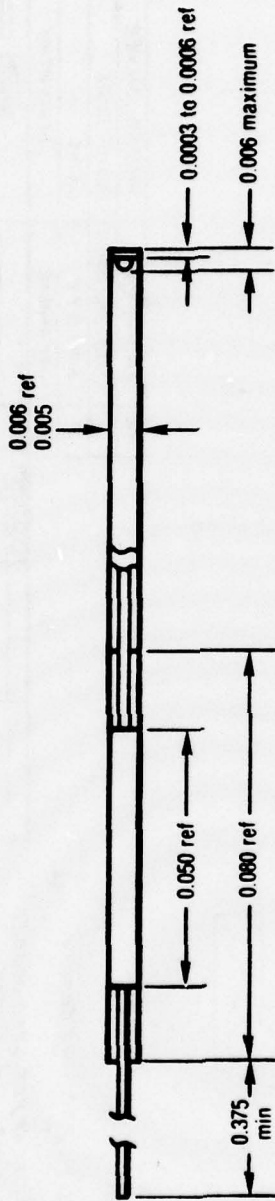

C-333

Approved source: Celesco Industries Inc.
Canoga Park, CA. 91304

Resistance matching 24Ω

Bridge thermal zero shift from -70° to 278° F to be linear within $\pm 1\%$

Average resistance at -70° F minus average resistance at 0° F to be a minimum of 15Ω . No difference to be greater than 18Ω on any one gage

Matching temperatures -70° , 0° , 78° and 278° F

Attached sets will be taped together: numbers 11-4 marked through with matching I.D. numbers. Four gages per set

Nominal gage factor to be $145 \pm 10\%$

Interest dwg in accordance with standards prescribed by MIL-STD-100A

Identify by stamping container with part no. and rev. letter of latest release in accordance with specifications

Figure C-235. Strain Sensor

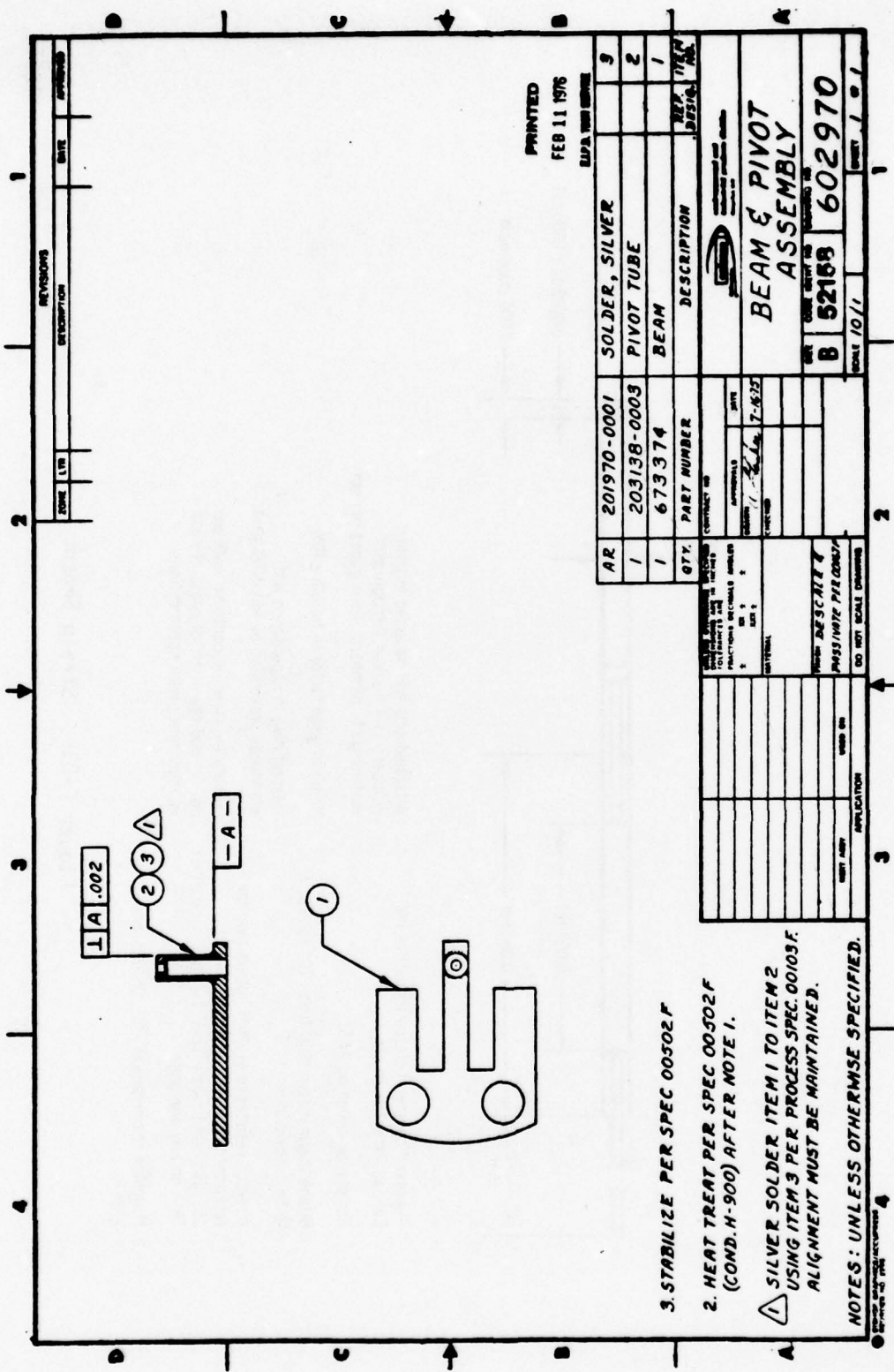

PRINTED
FEB 11 1976
DUPLICATE SERVICE

AR	201970-0001	SOLDER, SILVER	3
1	203138-0003	PIVOT TUBE	2
1	673374	BEAM	1
QTY.	PART NUMBER	DESCRIPTION	REF. ITEM DESIGNATION
CONTRACT NO. _____ DATE 17-6-75 APPROVALS _____ CHECKED _____ DRAWN BY _____ PARTS/INSTRUMENTS NUMBER _____ PART 1 _____ MATERIAL _____ PARTS DESCRIBED _____ PARTS/INSTRUMENTS PERFORMED _____ DO NOT SCALE DIMENSIONS			
BEAM & PIVOT ASSEMBLY			SHEET 1 OF 1
THE TOTAL COST OF THIS ORDER IS B 52158 602970			TABLE 10/1

- 3. STABILIZE PER SPEC 00502F
 - 2. HEAT TREAT PER SPEC 00502F (COND. N-900) AFTER NOTE 1.
 - 1. SILVER SOLDER ITEM 1 TO ITEM 2 USING ITEM 3 PER PROCESS SPEC. 00103F. ALIGNMENT MUST BE MAINTAINED.
- NOTES: UNLESS OTHERWISE SPECIFIED.

Figure C-236. Beam and Pivot Assembly

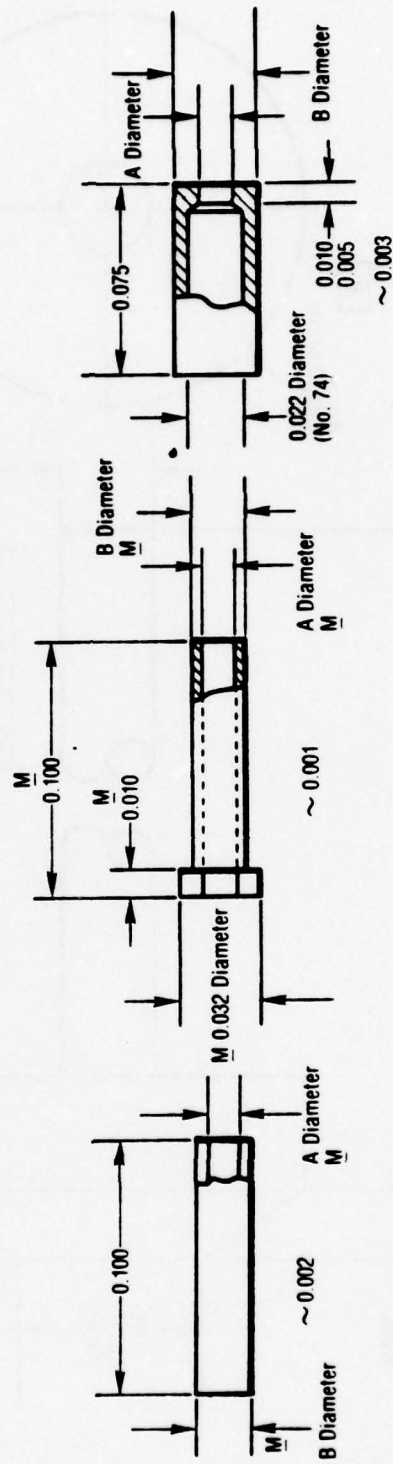

C-335

- ③ Material: CRES BAR 17-4PH, condition A per AMS 5643
- ② Material: NI-SPAN C per procurement specification 0 0019PS

Figure C-237. Pivot Tube

18518

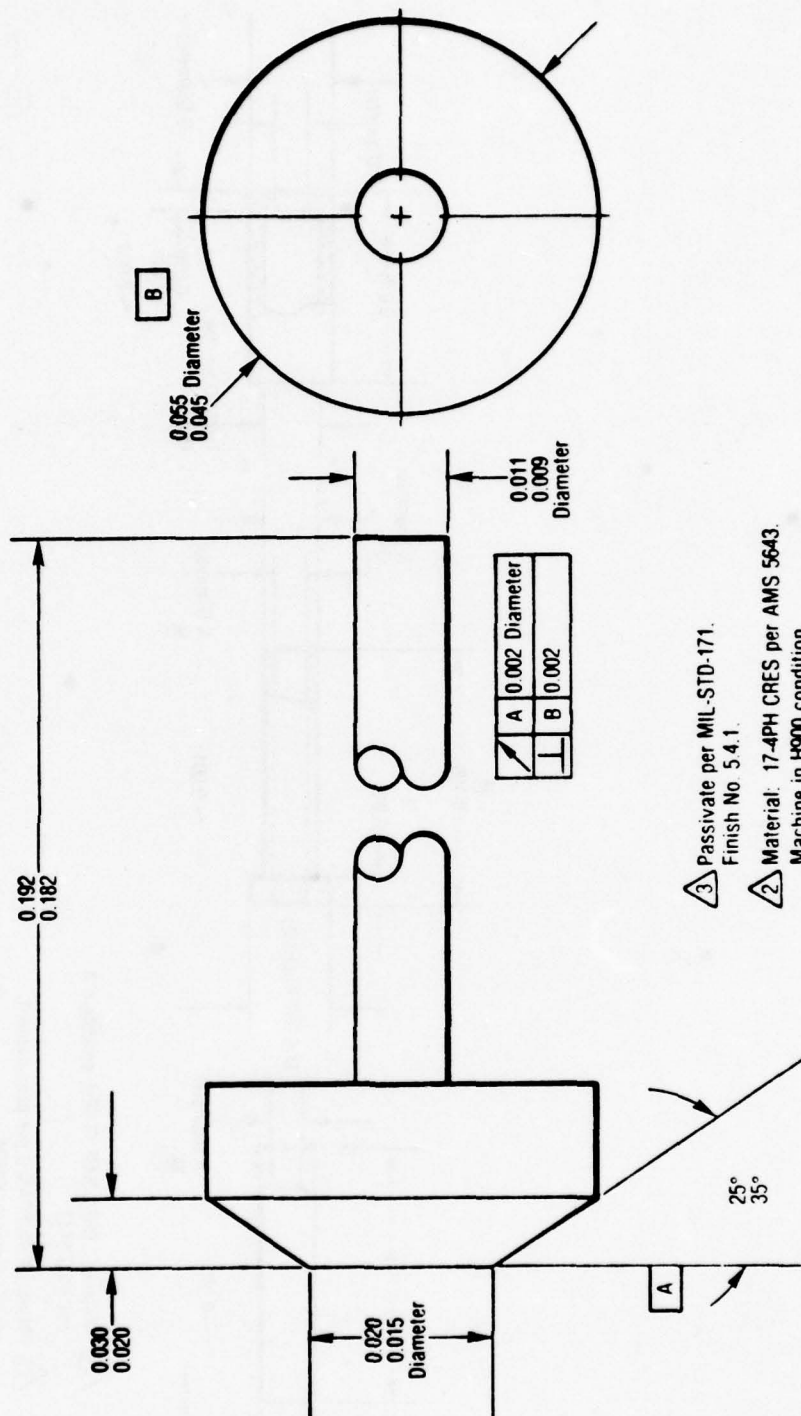

- ▧ Passivate per MIL-STD-171.
Finish No. 5.4.1.
- ▧ Material: 17-4PH CRES per AMS 5643.
Machine in H900 condition.

Figure C-238, Force Rod

18517

C-336

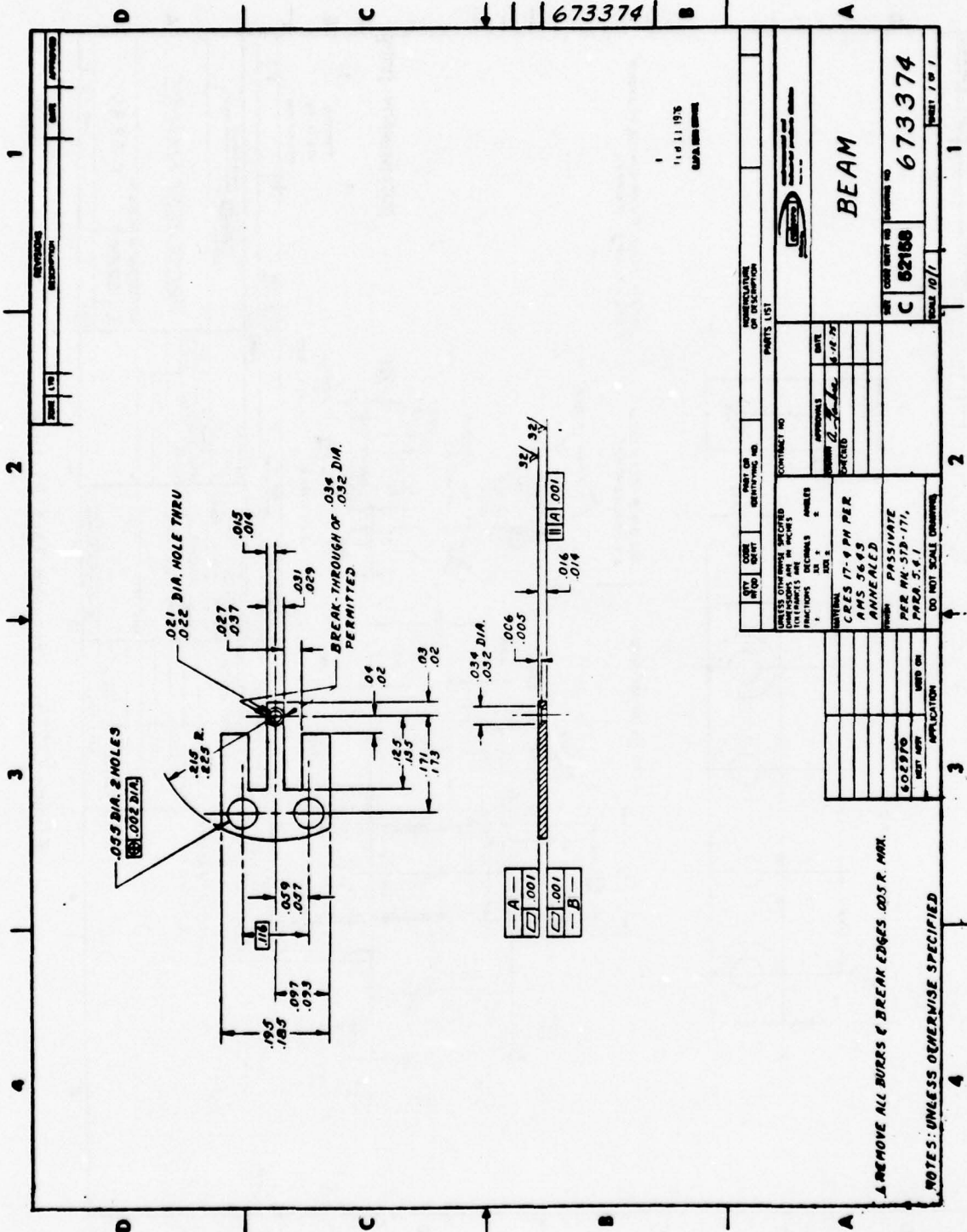

C-338



11/11/1975
LVA 808 8088

REV. NO.		REVISIONS		DATE		APPROVED	
QTY	CORE	PART OF	DESCRIPTION	DATE	APPROVALS	DATE	CONTRACT NO.
UNLESS OTHERWISE SPECIFIED DIMENSIONS ARE IN INCHES FRACTIONS DECIMALS ANGLES	AMS 5688	AMS 5688	AMS 5688	AMS 5688	AMS 5688	AMS 5688	AMS 5688
FINISH	CRS 17-9 PH PER	AMS 5688	ANNEALED	PER MIL-STD-171, PARA. 5.4.1	PASSIVATE	PER MIL-STD-171, PARA. 5.4.1	DO NOT SCALE DIMENSIONS
QTY	QTY	QTY	QTY	QTY	QTY	QTY	QTY
60290	60290	60290	60290	60290	60290	60290	60290
QTY	QTY	QTY	QTY	QTY	QTY	QTY	QTY
1	1	1	1	1	1	1	1
PART NO.		PART DESCRIPTION		PART LIST		PART / OF /	
C 52168		BEAM		C 52168		673374	
SCALE 10/1						PART / OF /	
						1	

Figure C-240. Beam

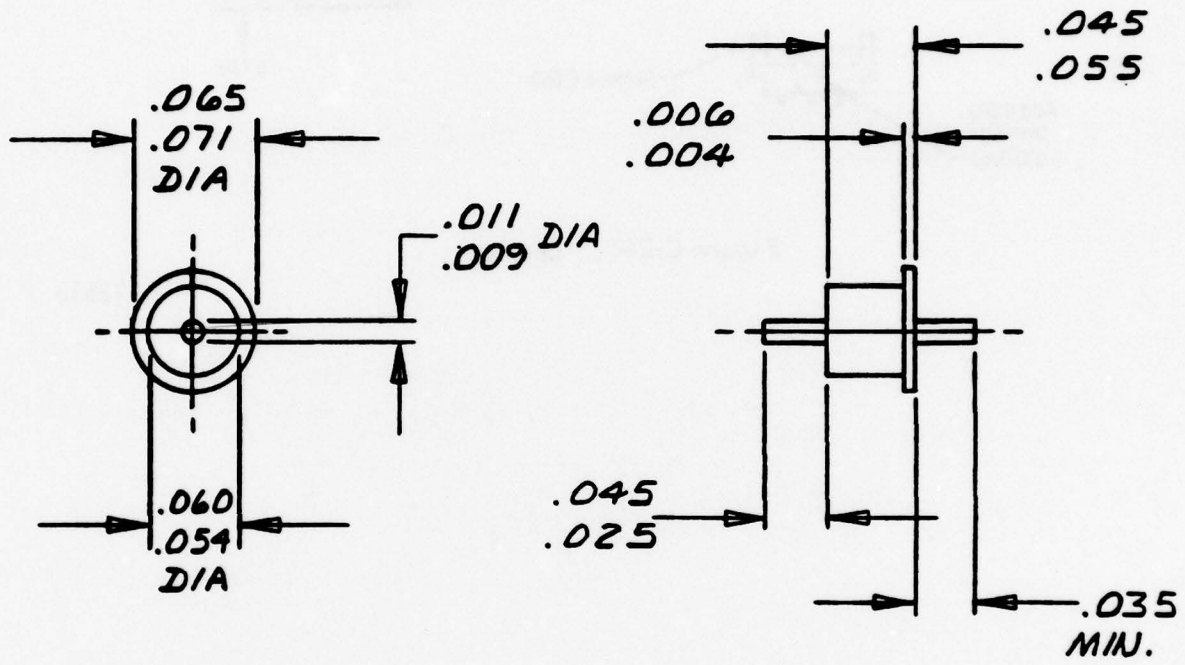
APPLICATION			REVISION			
NEXT ASSY	USED ON	LTR	DESCRIPTION	DATE	APPROVED	



UNLESS OTHERWISE SPECIFIED DIMENSIONS ARE IN INCHES TOLERANCES ARE: FRACTIONS DECIMALS ANGLES .XX ± ± .XXX ±	CONTRACT NO.		 environmental and industrial products division Camp Hill, Pa.
	APPROVALS	DATE	
DRAWN 	CHECKED		TERMINAL FEED THRU
MATERIAL			SIZE A CODE IDENT NO. 52158 DRAWING NO.
			SCALE 10/1 SHEET 1 OF 1
DIM DO NOT SCALE DRAWING	BISHOP GRAPHICS/ACCUPRESS REORDER NO. 2394		Figure C-241. Terminal Feed-Through C-339

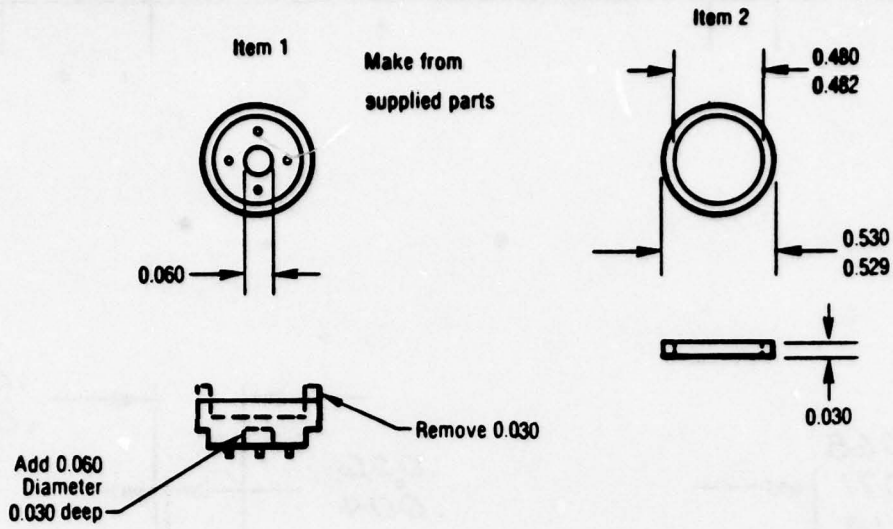
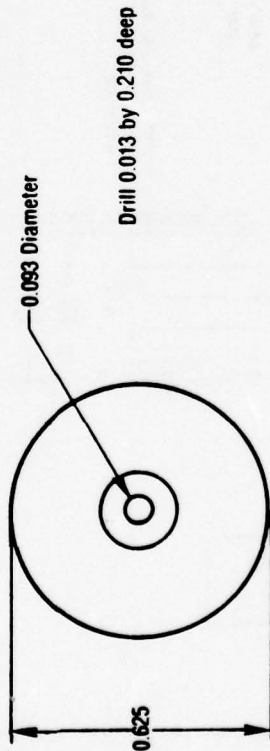
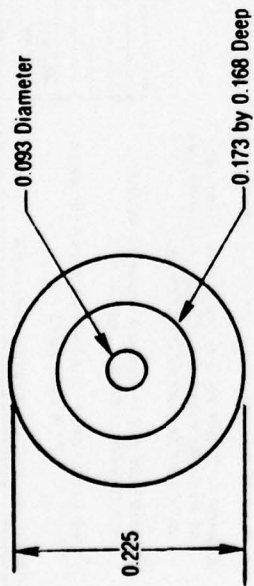
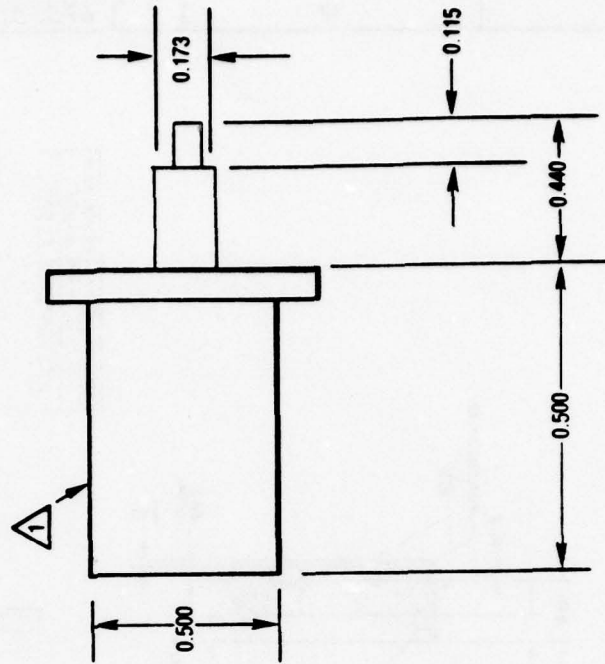
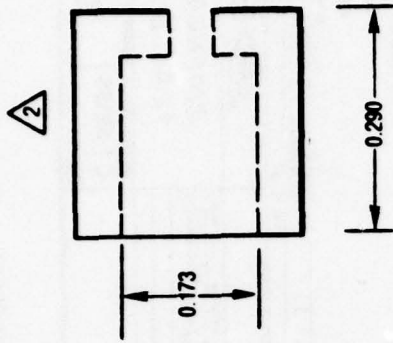

Figure C-242. Charge

18513



Note:
 1 Copper
 2 Nylon insulator



C-341

Figure C-243. Force Rod Welding Fixture

18514

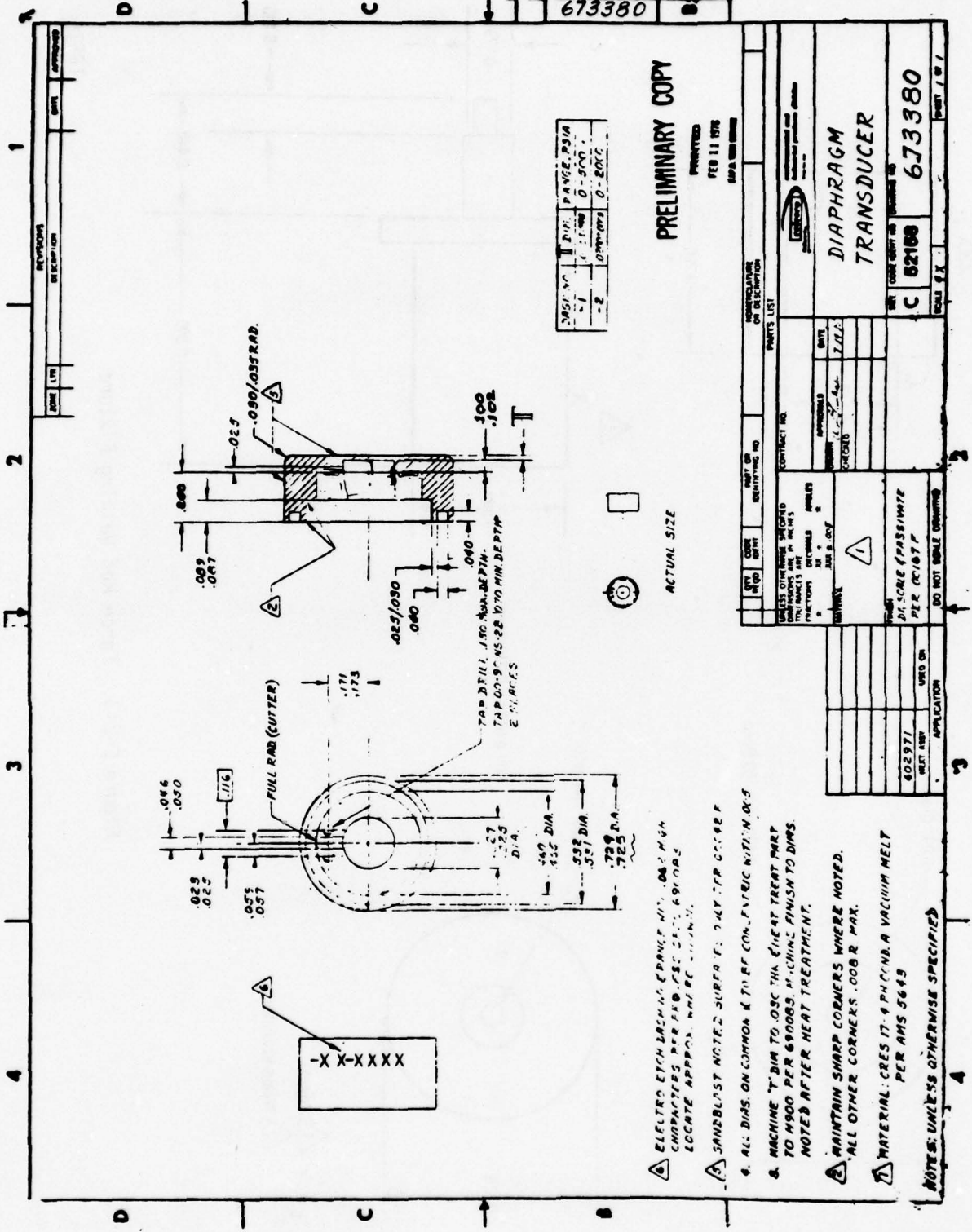
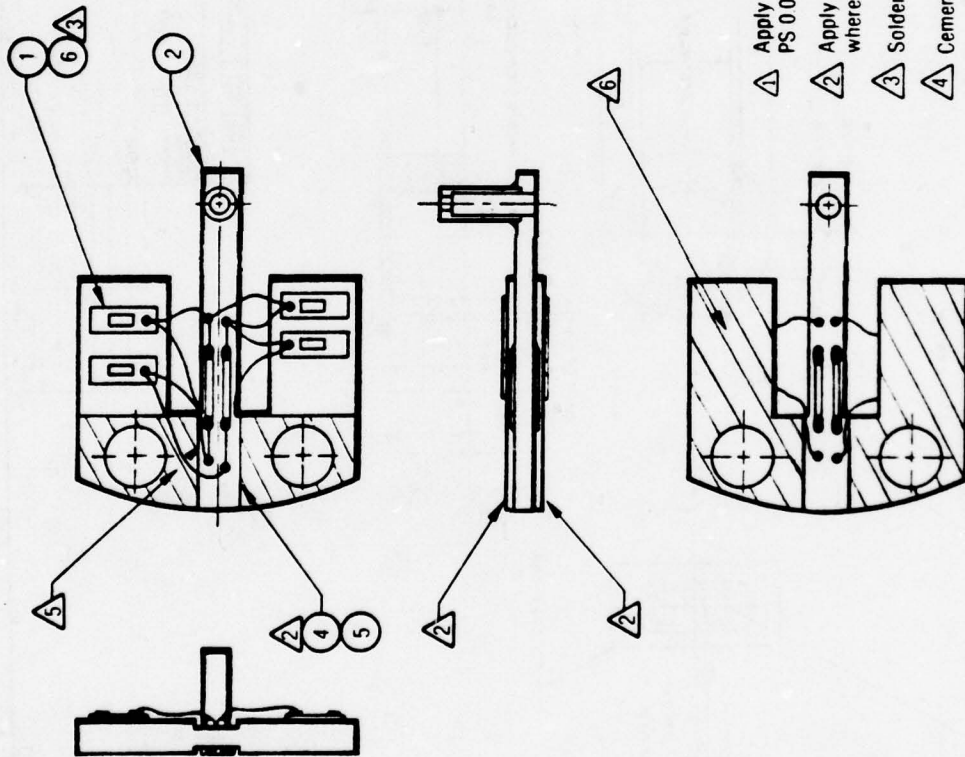
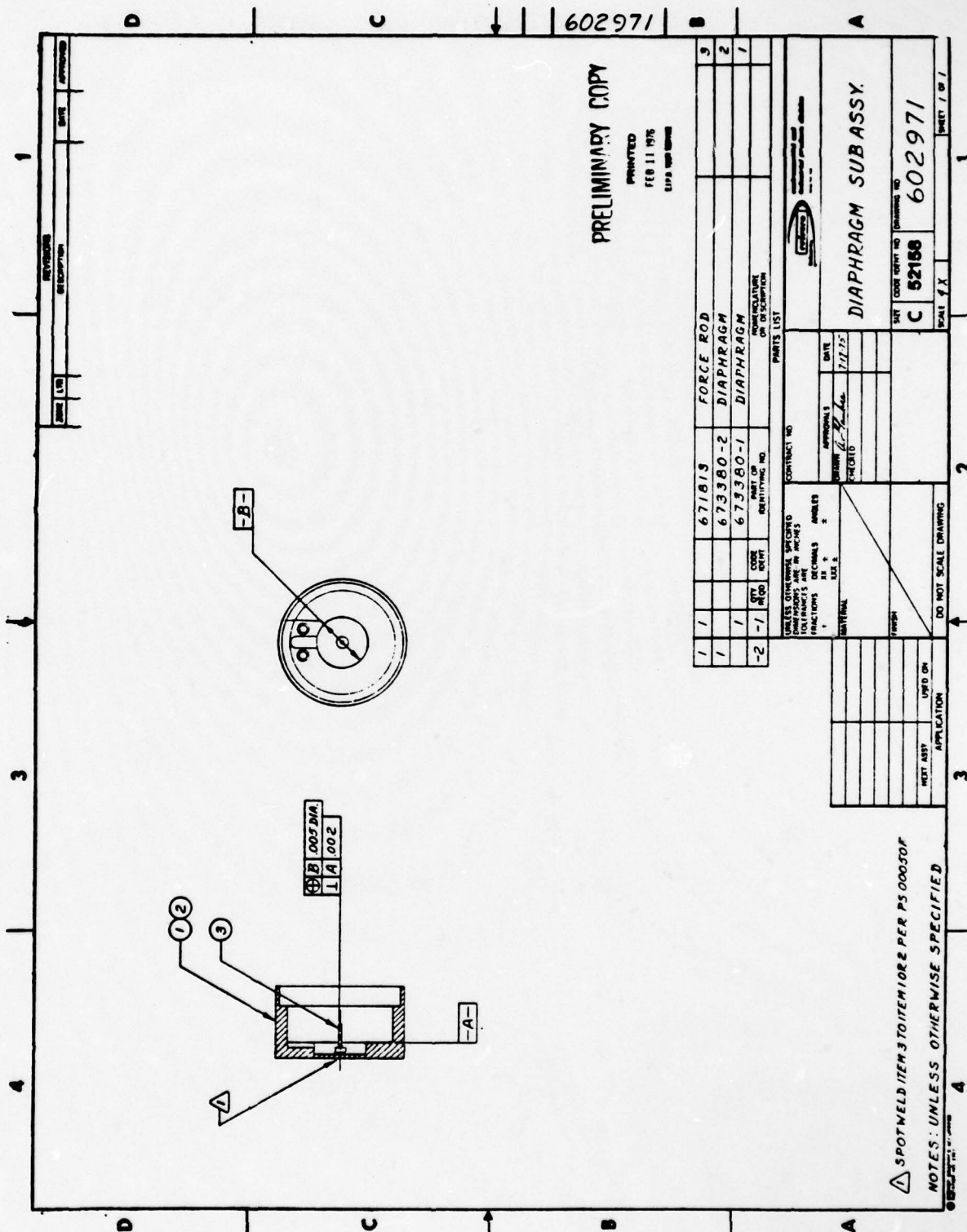

Figure C-244. Diaphragm Transducer



- ① Apply sensor, Item 4, and tabs, Item 1, as shown per PS 0.0012F.
- ② Apply cement, Item 5, to immediate area around Item 4 and where noted
- ③ Solder per PS 0.1001F
- ④ Cement gage leads to beam with epoxy
- ⑤ Shaded areas to be free of epoxy

Figure C-246. Beam and Gage Subassembly



PRELIMINARY COPY

PRINTED
FEB 11 1976
EPP 988 0000

QTY	UNIT	DESCRIPTION	CONTRACT NO.
1	1	671815 FORCE ROD	
1	1	673380-2 DIAPHRAGM	
1	1	673380-1 DIAPHRAGM	
-2	-1	DIAPHRAGM IDENTIFYING NO.	

CONTRACT NO. _____
 DATE 7/17/75
 DRAWN BY C. H. G. / J. G.
 CHECKED BY _____
 MATERIAL _____
 FINISH _____
 DO NOT SCALE DRAWING

DIAPHRAGM SUBASSY.

DRAWING NO. 602971
 SHEET 1 OF 1

△ SPOTWELD ITEM 3 TO ITEM 10 & 2 PER PS 000020F
 NOTES: UNLESS OTHERWISE SPECIFIED

Figure C-247. Diaphragm Subassembly

APPENDIX D

**CELESCO P-95 TRANSDUCER 500-HOUR
STABILITY DATA**

D-347

CONTENTS

Section		Page
1.0	TRANSDUCER STABILITY DATA SUMMARY - CELESCO P-95 DATA	D-351
2.0	P-95 DATA SUMMARY FOR SEVEN TRANSDUCERS	D-353

TABLES

Table		Page
D- 57	Functional Test Data for Transducer S/N 250858	D-354
D- 58	Functional Test Data Obtained During Burn-In for Transducer S/N 250858	D-355
D- 59	Functional Test Data for Transducer S/N 250857	D-356
D- 60	Functional Test Data Obtained During Burn-In for Transducer S/N 250857	D-357
D- 61	Functional Test Data for Transducer S/N 250856	D-358
D- 62	Functional Test Data Obtained During Burn-In for Transducer S/N 250856	D-359
D- 63	Functional Test Data for Transducer S/N 25083	D-360
D- 64	Functional Test Data Obtained During Burn-In for Transducer S/N 25083	D-361
D- 65	Functional Test Data for Transducer S/N 250862	D-362
D- 66	Functional Test Data Obtained During Burn-In for Transducer S/N 250862	D-363
D- 67	Functional Test Data for Transducer S/N 250860	D-364
D- 68	Functional Test Data Obtained During Burn-In for Transducer S/N 250860	D-365
D- 69	Functional Test Data for Transducer S/N 250859	D-366
D- 70	Functional Test Data Obtained During Burn-In for Transducer S/N 250859	D-367
D- 71	First and Last Calibration for 300 psia Transducer	D-368
D- 72	First and Last Calibration for 400 psia Transducer	D-371
D- 73	First and Last Calibration for 600 psia Transducer	D-372
D- 74	First and Last Calibration for 3,000 psia Transducer	D-373
D- 75	Percentage Full-Scale Zero Shift Through Burn-In At 0 Pressure	D-374

TABLES (Continued)

Table		Page
D-76	Percentage Full-Scale Shift Through Burn-In At 20% Full-Scale Pressure	D-376
D-77	Percentage Full-Scale Shift Through Burn-In At 40% Full-Scale Pressure	D-377
D-78	Percentage Full-Scale Shift Through Burn-In At 60% Full-Scale Pressure	D-378
D-79	Percentage Full-Scale Shift Through Burn-In At 80% Full-Scale Pressure	D-379
D-80	Percentage Full-Scale Shift Through Burn-In Full-Scale Pressure	D-380

1.0 TRANSDUCER STABILITY DATA SUMMARY - CELESCO P-95 DATA

The P-95 transducer is a rectangular cantilever, semiconductor strain gage transducer with integral electronics. The sensor yields 100 mV for a 500 μ strain load at full-scale pressure. The integral electronics consists of a DC (28 V) to DC converter and amplifier with a gain of 50. Hence, output is a DC signal of 0 to 5 V. Temperature range of the P-95 transducer is -10 to 140 $^{\circ}$ F. All components are 100% screened (purchased to mil specifications) and each end item is functionally tested including a 500-hr burn-in test to the acceptance test procedure for Celeco Part No. 631093.

Data included in this report are from steps 4.13 through 4.23 of the data packages of the Functional Test Steps listed below:

<u>Step</u>	<u>Step number</u>
Examination of products	4.1
Configuration and identification	4.1.1
In-process documentation	4.1.2
Sensor helium leak rate	4.1.3
Weight	4.1.4
Input to output isolation	4.2
Insulation Resistance	4.3
Dielectric strength test	4.4
Operating Current Test	4.5
Noise feedback test	4.6
Output noise test	4.7
Output regulation test	4.8
Output impedance test	4.9
Reverse polarity protection test	4.10
Over-voltage protection test	4.11
Over-pressure test	4.12
Static calibration	4.13
Pre-vibration - temperature cycling (2 cycles 140 $^{\circ}$ F \rightarrow 10 $^{\circ}$ F)	4.14

Functional Test Steps (Continued)

<u>Step</u>	<u>Step number</u>
Post-temperature cycling functional tests (same as 4.13)	4.15
Random vibration	4.16
Post-vibration functional tests (same as 4.13)	4.17
Post-vibration temperature cycling (same as 4.14)	4.18
Pre-temperature functional tests (same as 4.13)	4.19
Temperature and thermal stability tests	4.20
Post-temperature functional tests (same as 4.13)	4.21
Burn-in test	4.22
100 hr at ambient	
Seven cycles - 140°F -10°F 140°F	
(evenly spaced)	
Last 100 hr at 140°F	
Post-burn-in functional tests (same as 4.13)	4.23

Test Conditions

Unless otherwise specified all test shall be performed at the room temperature ambient conditions given below:

Temperature:	55°F to 95°F
Barometric Pressure:	650 to 810 torr
Relative Humidity:	90% or less

Environmental Tolerances

- | | |
|-------------------------------|--|
| a. Temperature (°F) | Plus or minus 5°F |
| b. Barometric Pressure (torr) | Plus or minus 5%,
900 torr to 1 torr
Plus or minus 10%,
1 torr to 10 ⁻⁵ torr |
| c. Relative Humidity | Plus or minus 5% of RH |

Data summaries for seven arbitrarily selected transducer numbers are taken from each of 10 calibrations spread over a 50-hr period, and a final calibration

after 500 hr. Complete data summaries was restricted to seven transducers because of budgetary constraints. Data are also given for the periodic health checks at 140°F and -10°F during the 500-hr burn-in test. For the remaining transducers, first and last calibration data are presented.

This Celesco pressure transducer design diaphragm thickness is adjusted to yield 500 μ at full-scale pressure for each of the pressure ranges. All metal parts are brazed together at 1,700°F and hardened before gaging to stabilize the metal. All transducers were exposed to 1,000 mechanical strokes and thermal cycling before the static calibration (4.13) was initiated at zero time.

The total transducer zero shift through the 500-hr burn-in was generally less than 0.5% of fullscale and the average for the 51 transducers was 0.19%. Average transducer shift at full-scale pressure during the 500-hr burn-in was 0.27%. These shifts in electrical output include both the contributions from the transducer and the integral electronics.

All measurements are within the specifications (0.75% full-scale static error) for these P-95 transducers which were developed for the Lockheed Missiles and Space Company. These transducers represent state-of-the-art in semiconductor pressure transducers for Celesco Industries.

2.0 P-95 DATA SUMMARY FOR SEVEN TRANSDUCERS

Electrical output of seven Celesco P-95 transducers was monitored during functional testing and are reported in Tables D57 through D-80. Both data before and during the burn-in test periods are presented. Ambient temperature zero shift comparisons are presented between the initial static test at zero time and after the 500-hr burn-in period. These seven transducers were well within the $\pm 0.75\%$ acceptance limit after the burn-in period.

TABLE D-57. FUNCTIONAL TEST DATA FOR TRANSDUCER S/N 250858

T5243

Room Ambient Functional Test Number		Test Tempera- ture	Hours	Zero (mV) 0	Percent Full-Scale Pressure Output (mV)				
					20	40	60	80	100
4.13	Static	Ambient	0	-5	1,002	2,007	3,009	4,005	4,998
4.15	Post Temp cycle	Ambient	17.5	1	1,008	2,011	3,012	4,007	4,999
4.17	Post Vib functional	Ambient	19.2	-6	1,001	2,006	3,009	4,005	4,998
4.19	Pre Temp function	Ambient	37.2	-2	1,006	2,010	3,012	4,008	5,001
4.21	Post Temp functional	-10	38.2	-3	1,005	2,012	3,016	4,012	5,006
-	-	140	39.2	-13	996	2,002	3,005	4,002	4,995
4.21	Function between Temp	Ambient	42.7	-4	1,001	2,006	3,008	4,004	4,998
-	-	-10	43.2	0	1,006	2,012	3,015	4,011	5,005
-	-	140	43.7	-15	994	1,999	3,002	3,998	4,992
4.21	Post Temp function test	Ambient	48.0	-6	1,001	2,006	3,008	4,004	4,997

Post Burn-In Test Initiated, 12/17/74

4.23	Post Burn-In functional test	Ambient	533	0	1,006	2,001	3,013	4,009	5,002
	Deviation from initial static test at 0 hr		Δ	5	4	4	4	4	4
	Ambient change from initial measurements		%F.S.	0.1	0.08	0.08	0.08	0.08	0.08

TABLE D- 58. FUNCTIONAL TEST DATA OBTAINED DURING BURN-IN
FOR TRANSDUCER S/N 250858

T5244

<u>140°F</u>		<u>Full-Scale Pressure Output (mV)</u>			
<u>Hours</u>	<u>0%</u>	<u>50%</u>	<u>100%</u>	<u>50%</u>	<u>0%</u>
72	-13	2,505	4,997	2,497	-18
120	-12	2,505	4,997	2,497	-19
168	-12	2,505	4,999	2,498	-18
216	-13	2,505	4,997	2,498	-19
264	-12	2,506	4,999	2,498	-18
296	-13	2,505	4,999	2,498	-19
340	-14	2,506	4,999	2,499	-19
408	-12	2,506	5,000	2,499	-16
456	-12	2,506	5,000	2,501	-16
480	-14	2,505	5,000	2,499	-18
504	-14	2,506	5,001	2,500	-18
528	-14	2,505	5,000	2,499	-18
532	-14	2,505	5,001	2,499	-18
<u>-10°F</u>					
96	-1	2,522	5,018	2,514	-8
144	-2	2,517	5,009	2,511	-8
192	0	2,518	5,009	2,512	-5
240	0	2,518	5,009	2,511	-5
288	0	2,517	5,007	2,511	-6
384	0	2,517	5,000	2,510	-6
432	-2	2,515	5,007	2,509	-7

TABLE D- 59. FUNCTIONAL TEST DATA FOR TRANSDUCER S/N 250857

T5245

Room Ambient Functional Test Number	Test Temperature	Hours	Zero (mV)		Percent Full-Scale Pressure Output (mV)				
			0	20	40	60	80	100	
4.13	Static	Ambient	0	0	1,006	2,010	3,013	4,010	5,003
4.15	Post Temp cycle	Ambient	17.5	4	1,010	2,015	3,017	4,015	5,008
4.17	Post Vib functional	Ambient	19.2	1	1,008	2,014	3,016	4,014	5,007
4.19	Pre Temp function	Ambient	37.2	2	1,007	2,011	3,013	4,011	5,003
4.21	Post Temp functional	-20	38.2	4	1,012	2,019	3,023	4,023	5,017
-	-	150	39.2	-23	984	1,991	2,995	3,995	4,990
4.21	Function between Temp	Ambient	42.7	1	1,007	2,011	3,013	4,011	5,004
-	-	-20	43.2	4	1,011	2,018	3,022	4,023	5,017
-	-	150	43.7	-24	983	1,990	2,995	3,995	4,991
4.21	Post Temp function test	Ambient	45.0	-1	1,003	2,007	3,008	4,005	4,998

Post Burn-In Test Initiated, 12/17/74

4.23	Post Burn-In functional test	Ambient	502	4	1,011	2,015	3,018	4,015	5,007
	Deviation from initial static test at 0 hr		Δ	4	5	5	5	5	4
	Ambient change from initial measurements		%F.S.	0.08	0.1	0.1	0.1	0.1	0.08

TABLE D- 6Q. FUNCTIONAL TEST DATA OBTAINED DURING BURN-IN
FOR TRANSDUCER S/N 250857

T5246

<u>140°F</u>		Full-Scale Pressure Output (mV)			
Hours	0%	50%	100%	50%	0%
70	-25	2,485	4,984	2,482	-27
118	-28	2,492	2,989	2,485	-26
166	-22	2,492	4,990	2,485	-24
214	-22	2,492	2,989	2,486	-25
262	-22	2,493	4,992	2,488	-24
310	-21	2,496	4,992	2,488	-23
358	-20	2,498	4,995	2,491	-22
406	-20	2,496	4,992	2,488	-23
430	-21	2,496	4,992	2,490	-23
454	-21	2,494	4,993	2,490	-23
478	-21	2,492	4,994	2,491	-23
502	-21	2,492	4,994	2,491	-23
<u>-10°F</u>					
94	7	2,520	5,012	2,513	6
142	7	2,419	5,013	2,515	5
190	7	2,518	5,012	2,511	6
238	8	2,518	5,014	2,513	7
286	8	2,520	5,017	2,514	6
334	10	2,520	5,013	2,515	9
382	8	2,517	5,015	2,514	6

TABLE D- 61. FUNCTIONAL TEST DATA FOR TRANSDUCER S/N 250856

T5247

Room Ambient Functional Test Number	Test Tempera- ture	Hours	Zero (mV)		Percent Full-Scale Pressure Output (mV)				
			0	20	40	60	80	100	
4.13	Static	Ambient	0	-11	1,021	2,028	3,031	4,028	5,021
4.15	Post Temp cycle	Ambient	17.5	-11	1,021	2,025	3,028	4,023	5,016
4.17	Post Vib functional	Ambient	19.2	0	1,010	2,016	3,020	4,016	5,010
4.19	Pre Temp function	Ambient	37.2	6	1,018	2,023	3,026	4,022	5,016
4.21	Post Temp functional	-20	38.2	9	1,025	2,037	3,045	4,046	5,043
-	-	150	39.2	20	1,033	2,040	3,045	4,042	5,037
4.21	Function between Temp	Ambient	42.7	2	1,011	2,017	3,020	4,016	5,010
-	-	-20	43.2	5	1,015	2,023	3,029	4,027	5,022
-	-	140	43.7	21	1,033	2,040	3,045	4,042	5,037
4.21	Post Temp function test	Ambient	48.0	1	1,012	2,018	3,021	4,017	5,011

Post Burn-In Test Initiated, 12/17/74

4.23	Post Burn-In functional test	Ambient	533	8	1,018	2,025	3,028	4,025	5,019
	Deviation from initial static test at 0 hr		Δ	-19	-3	-3	-3	-3	-2
	Ambient change from initial measurement		%F.S.	0.38	0.06	0.06	0.06	0.06	0.04

TABLE D-62. FUNCTIONAL TEST DATA OBTAINED DURING BURN-IN
FOR TRANSDUCER S/N 250856

T5248

<u>140°F</u>		<u>Full-Scale Pressure Output (mV)</u>			
<u>Hours</u>	<u>0%</u>	<u>50%</u>	<u>100%</u>	<u>50%</u>	<u>0%</u>
72	23	2,546	5,042	2,537	17
120	25	2,549	5,044	2,540	18
168	24	2,548	5,044	2,539	17
216	24	2,549	5,045	2,540	17
264	25	2,550	5,047	2,540	18
296	25	2,550	5,048	2,541	18
340	24	2,550	5,048	2,542	18
408	25	2,550	5,048	2,542	20
456	25	2,551	5,048	2,545	20
480	24	2,551	5,050	2,543	20
504	24	2,551	5,050	2,543	19
528	24	2,550	5,049	2,543	19
532	23	2,550	5,050	2,543	18
<u>-10°F</u>					
96	22	2,555	5,060	2,547	14
144	15	2,543	5,042	2,537	10
192	17	2,544	5,042	2,538	12
240	17	2,543	5,040	2,536	11
288	17	2,544	5,040	2,541	18
384	17	2,545	5,042	2,537	12
432	16	2,543	5,041	2,536	11

TABLE D-63. FUNCTIONAL TEST DATA FOR TRANSDUCER S/N 25083

T5249

Room Ambient Functional Test Number	Test Temperature	Hours	Zero (mV)		Percent Full-Scale Pressure Output (mV)				
			0	20	40	60	80	100	
4.13	Static	Ambient	0	3	1,008	2,012	3,010	4,010	4,998
4.15	Post Temp cycle	Ambient	17.5	8	1,015	2,020	3,022	4,020	5,013
4.17	Post Vib functional	Ambient	19.2	9	1,014	2,019	3,021	4,019	5,013
4.19	Pre Temp function	Ambient	37.2	11	1,020	2,024	3,026	4,024	5,017
4.21	Post Temp functional	-10	38.2	16	1,029	2,040	3,047	4,049	5,047
-	-	140	39.2	20	1,027	2,031	3,030	4,026	5,019
4.21	Function between Temp	Ambient	42.7	11	1,019	2,024	3,025	4,023	5,016
-	-	-10	43.2	16	1,029	2,039	3,046	4,048	5,045
-	-	140	43.7	20	1,026	2,030	3,030	4,026	5,019
4.21	Post Temp function test	Ambient	45.0	10	1,018	2,024	3,025	4,022	5,016

Post Burn-In Test Initiated, 12/17/74

4.23	Post Burn-In functional test	Ambient	502	19	1,028	2,034	3,036	4,033	5,026
	Deviation from initial static test at 0 hr		Δ	16	20	22	26	23	28
	Ambient change from initial measurement		%F.S.	0.32	0.40	0.44	0.52	0.46	0.56

TABLE D-64. FUNCTIONAL TEST DATA OBTAINED DURING BURN-IN
FOR TRANSDUCER S/N 25083

T5250

<u>140°F</u>	<u>Full-Scale Pressure Output (mV)</u>					
	<u>Hours</u>	<u>0%</u>	<u>50%</u>	<u>100%</u>	<u>50%</u>	<u>0%</u>
	70	30	2,530	5,020	2,528	27
	114	33	2,534	5,019	2,530	28
	166	38	2,541	5,026	2,538	35
	214	33	2,536	5,021	2,529	31
	262	32	2,542	5,026	2,533	28
	310	38	2,545	5,026	2,535	33
	358	44	2,551	5,032	2,542	40
	406	32	2,539	5,020	2,530	29
	430	33	2,544	5,029	2,536	29
	454	36	2,541	5,020	2,532	34
	478	33	2,538	5,025	2,533	32
	502	34	2,543	5,023	2,534	31
<u>-10°F</u>						
	94	32	2,558	5,049	2,545	29
	142	32	2,548	5,048	2,545	29
	190	36	2,555	5,048	2,544	32
	238	30	2,533	5,045	2,544	27
	286	36	2,557	5,051	2,549	34
	334	40	2,560	5,056	2,555	37
	382	34	2,554	5,050	2,548	31

TABLE D-65. FUNCTIONAL TEST DATA FOR TRANSDUCER S/N 250862

T5251

Room Functional Test Number	Ambient	Test Tempera- ture	Hours	Zero (mV)	Percent Full-Scale Pressure Output (mV)				
					0	20	40	60	80
4.13	Static	Ambient	0	-4	1,000	2,006	3,007	4,007	4,999
4.15	Post Temp cycle	Ambient	17.5	3	1,011	2,018	3,021	4,021	5,019
4.17	Post Vib functional	Ambient	19.2	4	1,009	2,016	3,020	4,021	5,018
4.19	Pre Temp function	Ambient	37.2	5	1,015	2,021	3,024	4,023	5,020
4.21	Post Temp functional	-20	38.2	26	1,036	2,044	3,049	4,050	5,048
-	-	150	39.2	-5	1,005	2,014	3,020	4,022	5,022
4.21	Function between Temp	Ambient	42.7	4	1,012	2,019	3,022	4,021	5,019
-	-	-20	43.2	25	1,036	2,043	3,048	4,048	5,045
-	-	150	43.7	-6	1,004	2,013	3,020	4,022	5,023
4.21	Post Temp function test	Ambient	45.0	6	1,015	2,022	3,025	4,024	5,021

Post Burn-In Test Initiated, 12/17/74

4.23	Post Burn-In functional test	Ambient	502	15	1,024	2,032	3,036	4,035	5,032
	Deviation from initial static test at 0 hr		Δ	19	24	26	29	28	33
	Ambient change from initial measurements		%F.S.	0.38	0.48	0.52	0.58	0.56	0.66

TABLE D-66. FUNCTIONAL TEST DATA OBTAINED DURING BURN-IN
FOR TRANSDUCER S/N 250862

T5252

<u>140°F</u>		<u>Full-Scale Pressure Output (mV)</u>			
<u>Hours</u>	<u>0%</u>	<u>50%</u>	<u>100%</u>	<u>50%</u>	<u>0%</u>
70	3	2,526	5,026	2,514	-1
114	7	2,520	5,025	2,516	1
166	11	2,528	5,031	2,522	7
214	7	2,524	5,028	2,514	1
262	5	2,528	5,031	2,519	1
310	11	2,531	5,032	2,520	7
358	18	2,538	5,038	2,526	11
406	5	2,525	5,028	2,517	0
430	6	2,531	5,036	2,522	2
454	9	2,526	5,026	2,518	4
478	6	2,526	5,031	2,520	3
502	6	2,530	5,031	2,521	4
<u>-10°F</u>					
94	42	2,561	5,052	2,548	37
142	41	2,555	5,051	2,548	36
190	47	2,558	5,050	2,546	41
238	40	2,556	5,048	2,545	35
286	47	2,562	5,054	2,554	41
334	51	2,565	5,058	2,556	46
382	46	2,560	5,051	2,551	39

TABLE D-67. FUNCTIONAL TEST DATA FOR TRANSDUCER S/N 250860

T5253

Room Ambient Functional Test Number	Test Tempera- ture	Hours	Zero (mV)		Percent Full-Scale Pressure Output (mV)				
			0	20	40	60	80	100	
4.13	Static	Ambient	0	0	1,005	2,010	3,010	4,010	4,998
4.15	Post Temp cycle	Ambient	17.5	8	1,016	2,022	3,024	4,023	5,017
4.17	Post Vib functional	Ambient	19.2	10	1,015	2,021	3,024	4,022	5,017
4.19	Pre Temp function	Ambient	37.2	14	1,022	2,028	3,030	4,028	5,022
4.21	Post Temp functional	-20	38.2	-1	1,010	2,022	3,029	4,033	5,032
-	-	150	39.2	1	1,008	2,013	3,014	4,010	5,003
4.21	Function between Temp	Ambient	42.7	12	1,021	2,026	3,028	4,026	5,019
-	-	-20	43.2	-1	1,012	2,022	3,029	4,032	5,031
-	-	150	43.7	0	1,007	2,012	3,013	4,010	5,003
4.21	Post Temp function test	Ambient	45.0	12	1,021	2,027	3,030	4,028	5,022

Post Burn-In Test Initiated, 12/17/74

4.23	Post Burn-In functional test	Ambient	502	26	1,025	2,041	3,045	5,036	
	Deviation from initial static test at 0 hr		Δ	26	20	31	35	26	24
	Ambient change from initial measurement		%F.S.	0.52	0.40	0.62	0.70	0.52	0.48

TABLE D-68. FUNCTIONAL TEST DATA OBTAINED DURING BURN-IN
FOR TRANSDUCER S/N 250860

T5254

<u>140°F</u>		<u>Full-Scale Pressure Output (mV)</u>			
<u>Hours</u>	<u>0%</u>	<u>50%</u>	<u>100%</u>	<u>50%</u>	<u>0%</u>
70	9	2,520	5,006	2,508	4
114	14	2,515	5,003	2,510	7
166	17	2,522	5,009	2,513	22
214	15	2,519	5,006	2,508	9
262	12	2,521	5,015	2,514	7
310	18	2,524	5,012	2,515	14
358	23	2,531	5,018	2,522	20
406	14	2,520	5,008	2,511	9
430	13	2,525	5,015	2,518	9
454	16	2,520	5,007	2,512	13
478	15	2,519	5,010	2,515	10
502	15	2,523	5,010	2,515	10
<u>-10°F</u>					
94	19	2,543	5,041	2,532	13
142	19	2,538	5,040	2,532	14
190	26	2,543	5,041	2,532	19
238	19	2,540	5,038	2,530	16
286	25	2,545	5,044	2,537	21
334	30	2,550	5,048	2,542	25
382	26	2,545	5,043	2,536	19

TABLE D-69. FUNCTIONAL TEST DATA FOR TRANSDUCER S/N 250859

T5255

Room Ambient Functional Test Number	Test Temperature	Hours	Zero (mV)	Percent Full-Scale Pressure Output (mV)					
				0	20	40	60	80	100
4.13	Static	Ambient	0	5	1,009	2,014	3,014	4,015	5,005
4.15	Post Temp cycle	Ambient	17.5	13	1,020	2,025	3,027	4,025	5,019
4.17	Post Vib functional	Ambient	19.2	15	1,019	2,024	3,026	4,024	5,019
4.19	Pre Temp function	Ambient	37.2	19	1,028	2,032	3,034	4,031	5,025
4.21	Post Temp functional	-20	38.2	3	1,014	2,023	3,028	4,030	5,027
-	-	150	39.2	36	1,043	2,046	3,048	4,045	5,039
4.21	Function between Temp	Ambient	42.7	20	1,027	2,031	3,033	4,031	5,025
-	-	-20	43.2	2	1,015	2,023	3,028	4,030	5,026
-	-	150	43.7	36	1,042	2,046	3,047	4,045	5,039
4.21	Post Temp function test	Ambient	45.0	16	1,023	2,028	3,029	4,028	5,022

Post Burn-In Test Initiated, 12/17/74

4.23	Post Burn-In functional test	Ambient	502	28	1,036	2,042	3,045	4,043	5,036
	Deviation from initial static test at 0 hr		Δ	23	27	28	31	28	31
	Ambient change from initial measurement		%F.S.	0.46	0.54	0.56	0.62	0.56	0.62

TABLE D-70. FUNCTIONAL TEST DATA OBTAINED DURING BURN-IN
FOR TRANSDUCER S/N 250859

T5256

<u>140°F</u> Hours	Full-Scale Pressure Output (mV)				
	0%	50%	100%	50%	0%
70	46	2,555	5,045	2,546	43
114	50	2,554	5,045	2,548	46
166	55	2,560	5,051	2,553	54
214	51	2,557	5,048	2,548	49
262	50	2,559	5,049	2,553	48
310	55	2,561	5,054	2,554	52
358	61	2,568	5,060	2,560	59
406	54	2,557	5,047	2,552	49
430	52	2,562	5,057	2,557	50
454	54	2,559	5,052	2,552	51
478	53	2,558	5,052	2,555	52
502	52	2,560	5,052	2,554	51
<u>-10°F</u>					
94	23	2,542	5,039	2,532	21
142	22	2,537	5,037	2,532	21
190	28	2,541	5,039	2,532	25
238	22	2,538	5,034	2,531	19
286	28	2,545	5,041	2,539	26
334	33	2,549	5,045	2,543	29
382	27	2,542	5,039	2,537	24

TABLE D-71. FIRST AND LAST CALIBRATION FOR 300 PSIA TRANSDUCER

T5257

Room Ambient

	Hours	0	20	40	60	80	100	
250841								
First	0	1	1,008	2,016	3,020	4,020	5,014	7/2/75
Last	502	16	1,023	2,031	3,036	4,036	5,032	8/6/75
250840								
First	0	4	1,009	2,015	3,018	4,018	5,014	7/2/75
Last	502	23	1,027	2,033	3,036	4,037	5,034	8/6/75
250839								
First	0	-6	1,003	2,009	3,014	4,013	5,010	2/22/75
Last	500	14	1,026	2,034	3,038	4,039	5,034	3/27/75
250838								
First	0	0	1,004	2,006	3,004	3,998	4,988	5/13/75
Last	502	7	1,012	2,013	3,010	4,004	4,993	6/26/75
250837								
First	0	0	1,003	2,005	3,008	4,010	5,013	2/22/75
Last	502	12	1,018	2,020	3,020	4,023	5,025	3/27/75
250836								
First	0	7	1,008	2,014	3,014	4,013	5,009	6/24/75
Last	502	22	1,027	2,034	3,037	4,037	5,032	8/6/75
250835								
First	0	-9	999	2,005	3,008	4,008	5,005	7/2/75
Last	502	2	1,009	2,015	3,018	4,019	5,015	8/6/75
250834								
First	0	5	1,005	2,011	3,009	4,009	5,003	3/25/75
Last	502	21	1,027	2,033	3,035	4,034	5,028	5/15/75
250833								
First	0	3	1,003	2,008	3,010	4,008	4,999	5/13/75
Last	502	4	1,011	2,016	3,018	4,015	5,008	6/16/75

TABLE D- 71. (Continued)

<u>Room Ambient</u>		Hours	0	20	40	60	80	100	
250832									
First	0	8	1,013	2,014	3,013	4,007	4,998	2/22/75	
Last	500	35	1,041	2,043	3,041	4,036	5,026	3/27/75	
250831									
First	0	-12	995	2,001	3,005	4,006	5,001	5/15/75	
Last	502	-10	998	2,005	3,008	4,009	5,005	6/26/75	
250816									
First	0	3	1,009	2,012	3,011	4,007	4,998	11/18/74	
Last	533	5	1,010	2,014	3,015	4,011	5,002	12/17/74	
250817									
First	0	-1	1,005	2,009	3,010	4,005	4,996	11/18/74	
Last	533	4	1,011	2,015	3,016	4,012	5,002	12/17/74	
250818									
First	0	7	1,006	2,011	3,013	4,011	5,005	11/18/74	
Last	553	5	1,014	2,022	3,026	4,027	5,022	12/17/74	
250819									
First	0	7	1,009	2,019	3,026	3,026	4,025	11/18/74	
Last	533	6	1,019	2,029	3,036	4,037	5,035	12/17/74	
250820									
First	0	9	1,018	2,024	3,026	4,023	5,016	7/2/75	
Last	502	20	1,029	2,036	3,039	4,038	5,031	8/6/75	
250822									
First	0	-7	996	2,006	3,007	4,011	5,008	3/25/75	
Last	502	0	1,009	2,019	3,025	4,028	5,026	5/15/75	
250823									
First	0	4	1,009	2,017	3,019	4,019	5,016	6/24/75	
Last	502	16	1,026	2,034	3,039	4,039	5,035	8/6/75	

TABLE D- 71.(Continued)

Room Ambient		Hours	0	20	40	60	80	100	
250824									
First	0	-13	995	2,003	3,007	4,009	5,004	2/22/75	
Last	500	-9	995	2,005	3,006	4,010	5,005	3/27/75	
250825									
First	0	-4	1,003	2,011	3,016	4,017	5,010	5/13/75	
Last	500	-3	1,007	2,016	3,020	4,020	5,015	6/26/75	
250826									
First	0	-7	995	1,999	2,999	3,994	4,983	5/13/75	
Last	502	1	1,006	2,009	3,009	4,004	4,994	6/26/75	
250827									
First	0	-8	993	2,001	3,001	4,002	4,997	3/25/75	
Last	502	-5	1,002	2,011	3,015	4,016	5,012	5/15/75	
250828									
First	0	-3	1,003	2,008	3,011	4,009	5,003	2/22/75	
Last	500	3	1,005	2,013	3,012	4,015	5,007	3/27/75	
250829									
First	0	11	1,014	2,022	3,020	4,021	5,015	3/25/75	
Last	502	22	1,030	2,038	3,042	4,041	5,035	5/15/75	

TABLE D-72. FIRST AND LAST CALIBRATION FOR 400 PSIA TRANSDUCER

T5258

<u>Room Ambient</u>		Hours	0	20	40	60	80	100	
250842									
First	0	-4	1,006	2,013	3,017	4,018	5,014		11/18/74
Last	532	-4	1,005	2,013	3,019	4,020	5,017		12/17/74
250843									
First	0	-6	1,001	2,006	3,008	4,005	4,996		12/6/74
Last	504	14	1,022	2,028	3,031	4,029	5,021		1/31/75
250844									
First	0	-6	998	2,006	3,013	4,016	5,013		12/6/74
Last	504	8	1,012	2,021	3,029	4,033	5,032		1/31/75
250845									
First	0	-2	1,003	2,009	3,012	3,010	5,002		12/6/74
Last	504	3	1,011	2,018	3,022	4,022	5,015		1/31/75
250846									
First	0	4	1,009	2,013	3,011	4,007	4,995		2/22/75
Last	500	33	1,038	2,041	3,040	4,035	5,023		3/27/75
250847									
First	0	-7	1,003	2,010	3,014	4,015	5,010		5/13/75
Last	502	5	1,010	2,013	3,011	4,005	4,992		6/26/75
250848									
First	0	12	1,012	2,015	3,019	4,013	4,999		6/24/75
Last	502	26	1,032	2,036	3,037	4,020	5,025		8/6/75
250849									
First	0	-9	1,002	2,011	3,016	4,018	5,014		7/2/75
Last	502	-4	1,005	2,014	3,019	4,008	5,020		8/6/75
250851									
First	0	-3	1,003	2,007	3,008	4,005	4,996		5/13/75
Last	502	9	1,017	2,022	3,022	4,020	5,009		6/26/75

TABLE D-72 (Continued)

<u>Room Ambient</u>		Hours	0	20	40	60	80	100	
250850									
First	0	-7	999	2,006	3,009	4,008	5,000		2/22/75
Last	500	18	1,028	2,035	3,038	4,038	5,030		3/27/75
250853									
First	0	5	1,005	2,010	3,015	4,011	4,999		6/24/75
Last	502	23	1,030	2,036	3,038	4,023	5,031		8/6/75
250854									
First	0	13	1,020	2,025	3,026	4,023	5,015		5/13/75
Last	500	33	1,040	2,044	3,044	4,040	5,031		6/26/75
250853									
First	0	-12	993	1,995	2,993	2,987	4,978		5/13/75
Last	500	-10	997	1,997	2,995	3,990	4,980		6/26/75

TABLE D-73. FIRST AND LAST CALIBRATION FOR 600 PSIA TRANSDUCER

T5259

<u>Room Ambient</u>		Hours	0	20	40	60	80	100	
250865									
First	0	-10	1,000	2,009	3,016	4,019	5,017		7/2/75
Last	502	-3	1,009	2,016	3,018	4,016	5,005		8/6/75
250866									
First	0	0	1,009	2,009	3,012	4,001	4,991		2/13/75
Last	504	20	1,026	2,031	3,032	4,025	5,015		1/31/75
250867									
First	0	3	1,008	2,012	3,013	4,009	4,997		2/22/75
Last	500	18	1,017	2,029	3,030	4,020	5,009		3/27/75
250868									
First	0	-20	995	2,000	3,005	4,008	4,997		3/25/75
Last	502	-11	1,002	2,011	3,019	4,017	5,013		5/15/75
250869									
First	0	-2	1,006	2,013	3,018	4,020	5,017		7/2/75
Last	502	0	1,010	2,013	3,015	4,010	5,001		8/6/75
250870									
First	0	-2	1,008	2,016	3,022	4,024	5,021		7/2/75
Last	502	13	1,026	2,030	3,033	4,029	5,020		8/6/75
250871									
First	0	0	1,008	2,013	3,014	4,010	4,998		2/22/75
Last	500	27	1,029	2,043	3,046	4,036	5,024		3/27/75

TABLE D- 74. FIRST AND LAST CALIBRATION FOR 3,000 PSIA TRANSDUCER

T5260

Room Ambient

	Hours	0	20	40	60	80	100	
250808								
First	0	0	1,003	2,005	3,005	3,999	4,998	12/6/74
Last	504	12	1,016	2,020	3,019	4,014	5,009	1/31/75
250809								
First	0	-4	998	2,003	3,002	4,001	4,996	12/6/74
Last	504	14	1,015	2,023	3,021	4,019	5,011	1/31/75
250810								
First	0	-5	1,000	2,002	2,999	3,991	4,985	12/6/74
Last	505	21	1,026	2,031	3,023	4,018	5,010	1/31/75
250812								
First	0	-17	992	1,997	2,998	3,097	4,990	5/15/75
Last	503	5	1,015	2,012	3,007	4,000	4,992	6/26/75
250813								
First	0	6	997	1,992	2,993	3,996	4,996	3/25/75
Last	502	17	1,014	2,009	3,010	4,014	5,015	5/15/75
250814								
First	0	-12	984	1,983	2,986	3,992	4,995	7/3/75
Last	502	3	999	1,997	3,002	4,008	5,008	8/6/75

First	0	-1	1,001	2,005	3,006	4,006	4,998	3/25/75
Last	500	9	1,016	2,019	3,021	4,019	5,014	5/15/75

AD-A073 660

UNITED TECHNOLOGIES CORP SUNNYVALE CALIF CHEMICAL SY--ETC F/G 9/1
THE DEVELOPMENT OF IMPROVED NORMAL STRESS TRANSDUCERS FOR PROPE--ETC(U)
JUN 79 E C FRANCIS, R E THOMPSON, W E BRIGGS F04611-75-C-0042

UNCLASSIFIED

CSD-2548-FR-VOL-2

AFRPL-TR-79-34-VOL-2

NL

2 of 4

AD
A073660



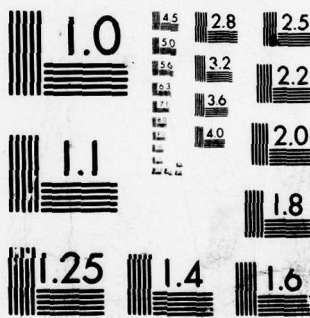

MICROCOPY RESOLUTION TEST CHART
NATIONAL BUREAU OF STANDARDS-1963-A

TABLE D-75. PERCENTAGE FULL-SCALE ZERO SHIFT THROUGH BURN-IN
AT 0 PRESSURE

T5261

Design Range	300 psia	400 psia	600 psia	3,000 psia
1	0.30	0	0.14	0.24
2	0.38	0.40	0.40	0.36
3	0.40	0.28	0.30	0.52
4	0.14	0.10	0.18	0.44
5	0.24	0.58	0.04	0.46
6	0.30	0.24	0.30	0.30
7	0.22	0.28	0.52	0.20
8	0.34	0.10		
9	0.14	0.24		
10	0.54	0.50		
11	0.04	0.36		
12	0.04	0.40		
13	0.10	0.04		
14	0.10			
15	-0.02			
16	0.22			
17	0.14			
18	0.24			
19	0.08			
20	-0.02			
21	0.16			
22	0.06			
23	0.12			
24	0.22			
Average	0.190			

TABLE D-76. PERCENTAGE FULL-SCALE SHIFT THROUGH BURN-IN
AT 20% FULL-SCALE PRESSURE

Design Range	T5262			
	300 psia	400 psia	600 psia	3,000 psia
1	0.30	-0.02	0.18	0.26
2	0.36	0.42	0.34	0.34
3	0.46	0.28	0.18	0.52
4	0.16	0.16	0.14	0.46
5	0.30	0.58	0.08	0.34
6	0.38	0.14	0.32	0.30
7	0.20	0.40	0.42	0.30
8	0.44	0.06		
9	0.16	0.38		
10	0.56	0.58		
11	0.06	0.50		
12	0.02	0.40		
13	0.14	0.08		
14	0.16			
15	0.20			
16	0.22			
17	0.26			
18	0.34			
19	0			
20	0.08			
21	0.22			
22	0.18			
23	0.04			
24	0.32			
Average	0.232			

TABLE D-77. PERCENTAGE FULL-SCALE SHIFT THROUGH BURN-IN
AT 40% FULL-SCALE PRESSURE

T5263

Design Range	300 psia	400 psia	600 psia	3,000 psia
1	0.30	0	0.14	0.30
2	0.36	0.44	0.44	0.40
3	0.46	0.30	0.34	0.58
4	0.14	0.18	0.22	0.30
5	0.30	0.56	0	0.34
6	0.40	0.06	0.28	0.34
7	0.30	0.42	0.40	0.28
8	0.44	0.06		
9	0.16	0.30		
10	0.58	0.58		
11	0.08	0.52		
12	0.04	0.38		
13	0.12	0.04		
14	0.22			
15	0.20			
16	0.24			
17	0.26			
18	0.34			
19	0.04			
20	0.10			
21	0.20			
22	0.20			
23	0.10			
24	0.32			
Average	0.246			

TABLE D-78. PERCENTAGE FULL-SCALE SHIFT THROUGH BURN-IN
AT 60% FULL-SCALE PRESSURE

T5264

Design Range	300 psia	400 psia	600 psia	3,000 psia
1	0.32	0.04	0.04	0.28
2	0.36	0.46	0.40	0.38
3	0.48	0.32	0.34	0.48
4	0.12	0.20	0.28	0.18
5	0.28	0.58	-0.06	0.34
6	0.46	-0.06	0.22	0.32
7	0.20	0.36	0.64	0.30
8	0.52	0.06		
9	0.16	0.28		
10	0.56	0.58		
11	0.06	0.46		
12	0.08	0.36		
13	0.12	0.04		
14	0.26			
15	0.20			
16	0.36			
17	0.36			
18	0.40			
19	-0.02			
20	0.08			
21	0.20			
22	0.28			
23	0.02			
24	0.44			
Average	0.2641			

TABLE D- 79. PERCENTAGE FULL-SCALE SHIFT THROUGH BURN-IN
AT 80% FULL-SCALE PRESSURE

T5265

Design Range	300 psia	400 psia	600 psia	3,000 psia
1	0.32	0.02	0.06	0.30
2	0.38	0.48	0.48	0.36
3	0.52	0.34	0.22	0.58
4	0.12	0.24	0.18	0.06
5	0.26	-0.20	-0.20	0.36
6	0.54	0.14	0.10	0.32
7	0.14	-0.20	0.52	0.26
8	0.50	0.30		
9	0.14	0.60		
10	0.58	0.26		
11	0.06	0.34		
12	0.08	0.06		
13	0.14	0.48		
14	0.32			
15	0.22			
16	0.30			
17	0.38			
18	0.40			
19	0.02			
20	0.06			
21	0.20			
22	0.28			
23	0.12			
24	0.40			
Average	0.270			

TABLE D-80. PERCENTAGE FULL-SCALE SHIFT THROUGH BURN-IN
FULL-SCALE PRESSURE

T5266

Design Range	300 psia	400 psia	600 psia	3,000 psia
1	0.08	0.06	-0.22	0.22
2	0.12	0.50	0.48	0.30
3	0.34	0.38	0.24	0.50
4	0.20	0.26	0.32	0.04
5	0.30	0.56	-0.32	0.38
6	0.32	-0.36	-0.02	0.26
7	0.38	0.52	0.52	0.32
8	0.02	0.12		
9	0.10	0.26		
10	0.22	0.60		
11	0.30	0.62		
12	0.08	0.32		
13	0.40	0.04		
14	0.36			
15	0.40			
16	0.48			
17	0.10			
18	0.24			
19	0.46			
20	0.20			
21	0.18			
22	0.56			
23	0.08			
Average	0.2675			

51 TOTAL UNITS

APPENDIX E

COMPARISON OF 17-4 PH AND 15-5 PH STAINLESS STEEL PROPERTIES
PRECIPITATION HARDENABLE STAINLESS STEEL

Selection of the stainless steel for the transducer body was partially made using information provided by Republic Steel Corporation. This information is printed here through permission granted by Republic Steel provided in the letter appearing on the following page.

Republicsteel

Republic Steel Corporation
General Offices: Republic Building
Market Communications and Advertising
PO Box 6778
Cleveland OH 44101
Tel 216/574-7100

LT Young
Director
Market Communications
and Advertising
HTS Heckman
Director
Creative Services
SM Gates
Assistant Manager
Advertising

Mr. R. E. Thompson
Research Engineer
Chemical Systems Division
PO Box 358
Sunnyvale CA 94088

April 17, 1979

Dear Mr. Thompson:

This is to acknowledge receipt of your letter of April 11 concerning your writing of a technical report to the Air Force Rocket Propulsion Laboratory at Edwards, California. You further state in your letter you would like to include in the course of your report a Republic Steel product bulletin on the comparison of 17-4 and 15-5 PH stainless steel.

You may use this letter as your authority to include the bulletin in your report providing the credit line "Courtesy of Republic Steel Corporation" is also included to designate the source of the bulletin, or any information contained therein.

Thank you for this opportunity to be of service. For our records, we would appreciate receiving a copy of your report when issued, if possible.

Very truly,

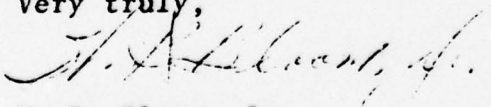

W. R. Bloom, Jr.
Account Executive
Market Communications and
Advertising

WRB/smm

AMS AND GOVERNMENT SPECIFICATIONS

<u>Grade</u>	<u>Specification</u>	<u>Commodity</u>
15-5 PH	AMS 5658	Bar-Billet
	AMS 5659	Vor Melt Bar - Billet
17-4 PH	AMS 5643	Bar-Billet
	AMS 5604	Plate-Sheet-Strip
	MIL-C-24111	Bar-Billet
	MIL-S-81506	Plate-Sheet-Strip
	ASTM-A-461-65-GR.630	Bar-Billet

What is Precipitation Hardening

Precipitation Hardening is a method of increasing the hardness and strength of a metal. Although some variations are necessary with specific types, generally it is accomplished by a three step heat treatment consisting of:

1. Solution Treatment
2. Rapid Cooling
3. Controlled Reheating

The first step of precipitation hardening involves heating to dissolve specially added elements (or compounds) which are normally insoluble at room temperature. This metal heating operation is referred to as solution treating (or solution annealing, or just annealing) and might be compared with the ability of hot water to dissolve more salt than can cold water.

The second step involves cooling the metal fast enough to assure retention of the solution effect at room temperature. Air cooling or oil quenching usually provides adequate cooling rates to achieve this

superaturated solid-solution condition.

The third step merely involves reheating of the supersaturated metal to some relatively low aging temperature, such as 900° F, for perhaps one hour. This reheating effects a uniform sub-microscopic precipitation of the special elements (or compounds of these elements) throughout the structure of the metal. This "keys" the structure by inhibiting the ability of one plane of atoms to slip over another plane of atoms, thereby hardening and strengthening the metal. *Precipitation hardening* has occurred.

Actually, there are three principal mechanisms of hardening a metal: work hardening, transformation hardening as in regular steel, and precipitation hardening. Precipitation hardening is most similar to work hardening because, generally, no transformation need be involved. Where applicable, therefore, precipitation hardening is the

best mechanism, in that uniform hardening is achieved without either the requirement of cold working, or the necessity of dealing with the problems of distortion and heavy scaling that are associated with the transformation hardening.

The aging temperature and time determine the degree of aging or hardening that takes place by influencing the size and distribution of the sub-microscopic precipitate. If, for example, a temperature somewhat above the specified aging temperature for a specific alloy were used, these sub-microscopic particles would agglomerate and grow. This would "unkey" the hardened structure and the metal would become softer. This reaction is called *over-aging* and could be employed to soften such a hardened metal if desired. For this same reason, precipitation hardened metals are seldom employed where service temperatures would exceed the precipitation hardening (aging) temperature.

The Martensitic Class

Republic 17-4 PH and 15-5 PH are special chromium—nickel—copper alloy stainless grades that achieve their strength and hardness through a combination of a martensitic transformation and precipitation hardening. Relatively high percentages of chromium and nickel give them excellent corrosion resistance—in most applications and media, comparable to that of Types 302 and 304. Close control of the composition and the addition of copper permit them to

be hardened by low temperature heat treatment.

Republic 17-4 PH, although available also as vacuum arc remelted quality, is generally sold as an air melted product and has become one of the most widely used of all the standard PH stainless grades—especially where longitudinal strength is required in ordinary section sizes.

Republic 15-5 PH, produced and marketed only as vacuum arc re-

melted quality, is a later development alloy that offers all the advantages of 17-4 PH plus excellent transverse toughness and very good forgeability. (The chemistry of Republic 15-5 PH practically eliminates a secondary structural phase called delta ferrite which results in improved hot workability.) Vacuum remelting enhances ductility and toughness and assures better uniformity of properties throughout heavy sections.

Available Conditions

These grades are normally supplied in the **SOLUTION HEAT TREATED** condition (Condition A) where the fabrication calls for machining, welding or minor cold forming operations subsequent to performing step 3 (aging) as outlined on page 6. (Parts should not be put into service in Condition A.)

If the fabrication requires forging, these grades are supplied by

the mill in the **OVERAGED** condition to eliminate the possibility of cracking upon rapid heating. After hot work, parts are heat treated by using steps 1, 2, and 3 as outlined on page 6.

When the fabrication requires nominal cold forming and developed strength, Republic 17-4 PH and 15-5 PH can be furnished by the mill in one of the more ductile hardened conditions such as **CONDI-**

TION H 1075 or **CONDITION H 1150**. No further heat treatment of parts is required.

Where optimum machinability is needed, heat treated **CONDITION H 1150M** may be ordered from the mill. Although this heat treatment produces typical mechanical properties slightly lower than Condition H 1150, higher properties can be developed by additional heat treatment after machining.

TYPICAL APPLICATIONS

Valves
Ball Bearings
Bolts
Motor Shafts
Gears
Splines
Instrument Part
Mandrels
Forgings
Piston Ring Expanders
Propeller Shafts
Pump Gears
Turbine Valves
Valve Seats
Fasteners
Roller Chain Pins

CHEMISTRY OF REPUBLIC 17-4 PH AND 15-5 PH

	17-4 PH	15-5 PH
	(Percent)	
Carbon.....	0.07 Max.	0.07 Max.
Manganese.....	1.00 Max.	1.00 Max.
Phosphorous.....	0.04 Max.	0.04 Max.
Sulphur.....	0.03 Max.	0.03 Max.
Silicon.....	1.00 Max.	1.00 Max.
Nitrogen.....	0.015 Max.	0.015 Max.
Chromium.....	15.50 — 17.50	11.00 — 15.50
Nickel.....	3.00 — 5.00	3.50 — 5.50
Columbium plus Tantalum.....	0.15 — 0.45	0.15 — 0.45
Copper.....	3.00 — 5.00	2.50 — 4.50

*Description of Standard Heat Treatments
for Republic 17-4 PH and 15-5 PH*

There are five standard heat treatments which are coded as: *Condition H 900, Condition H 925, Condition H 1025, Condition H 1075, and Condition H 1150*. The numbers 900, 925, 1025, 1075, 1150 indicate the aging or precipitation hardening temperature employed. As this temperature in-

creases, the developed strength level declines but the ductility and the toughness improve. For example, *Condition H 900* exhibits 200,000 psi ultimate tensile strength, 50% reduction-of-area and 20 ft. lbs. impact strength. *Condition H 1075* develops 165,000 psi, 60% reduction-of-area and 40 ft. lbs.

Treatment	Discussion	
<p align="center">STEP No. 1</p> <p>Solution treat at 1900° ±25° F</p>	<p>The customer normally orders 17-4 PH and 15-5 PH to be supplied by the mill in this condition ("Condition A" or "Solution Heat Treated"). When the customer's application requires forging, this grade should be supplied in the overaged condition. Subsequent to forging, the customer performs this step as part of the heat treating cycle.</p>	<p>The purposes of this step are:</p> <ol style="list-style-type: none"> (1) to austenitize the steel so that high strength martensite is developed on cooling. (2) dissolve copper, thereby conditioning the steel for subsequent age hardening or precipitation hardening.
<p align="center">STEP No. 2</p> <p>Cool to below 80° F</p>		<p>Cooling to below 80° F is required to insure full transformation to martensite. This is a critical requirement for this alloy because, although the transformation to martensite starts at about 400° F, it is not finished until a tem-</p>
<p align="center">STEP No. 3</p> <p>—Cond. H 900—Heat to 900° F, hold 1 hr., air cool. —Cond. H 925—Heat to 925° F, hold 4 hrs., air cool. —Cond. H 1025—Heat to 1025° F, hold 4 hrs., air cool. —Cond. H 1075—Heat to 1075° F, hold 4 hrs., air cool. —Cond. H 1100—Heat to 1100° F, hold 4 hrs., air cool. —Cond. H 1150—Heat to 1150° F, hold 4 hrs., air cool.</p>	<p><i>Normally, the steel is fabricated prior to this step.</i></p> <p>Age hardening or precipitation hardening (due to the precipitation of copper) occurs during this step which further increases the strength and hard-</p>	<p>ness of the martensite which formed during Step No. 1. However, as the aging temperature increases, "overaging" occurs, thereby progressively lowering the strength but improving the ductility of the heat treated product.</p>

ROOM TEMPERATURE MECHANICAL PROPERTIES

(Acceptable for Material Specifications)

REPUBLIC 17-4 PH AND 15-5 PH

Rounds, Hexagons and Squares (Condition A)

$\frac{1}{8}$ " and Smaller.....175,000 psi max. ultimate tensile
 Over $\frac{1}{8}$ " to $\frac{1}{2}$ ".....RC 38 max.
 Over $\frac{1}{2}$ " to 3".....BHN 341 max.
 Over 3".....BHN 363 max.

Sheet and Strip (Condition A)

Up to 0.187" Thick.....RC 38 max.

Plate and Flats (Condition A)

0.1875" to 3" Thick.....BHN 341 max.
 Over 3" Thick.....BHN 363 max.

In Tables I and II are listed mechanical properties for the various aging treatments which should be considered for specification requirements and which can be ac-

cepted. This does not mean, however, that customers are limited to these temperatures. For their own particular use, it may be desirable to vary slightly from the tempera-

tures shown. Information regarding larger section sizes is available upon request.

TABLE I

MINIMUM PROPERTIES

Longitudinal Direction - - Intermediate Location

Republic 17-4 PH

Up to 8" section

Republic 15-5 PH

Up to 12" section

Condition	H 900	H 925	H 1025	H 1075	H 1100	H 1150	H 1150-M
Ultimate Tensile Strength - psi	190,000	170,000	155,000	145,000	140,000	135,000	115,000
0.2% Yield Strength - psi	170,000	155,000	145,000	125,000	115,000	105,000	75,000
Elongation, % in 2" or 4 x D	10.0(1)	10.0(1)	12.0(1)	13.0(1)	14.0(2)	16.0(2)	18.0(2)
Reduction of Area - %	35.0	38.0	45.0	45.0	45.0	50.0	55.0
Brinell	388/448	375/438	331/401	302/375	311/364	277/352	255/293
Rockwell	C 40/47	C 38/45	C 35/42	C 31/39	C 32/38	C 28/37	C 24/30
Impact, Charpy V-Notch, ft-lbs	*	5	15	20	25	30	55

*Minimum impact properties cannot be accepted in this condition.

(1) For sheet sizes (under .187" thick) minimum elongation is 5%.

(2) For sheet sizes (under .187" thick) minimum elongation is 8%.

TABLE II

MINIMUM PROPERTIES

Transverse Direction (1)

Republic 15-5 PH

Up to 12" section

Condition	H 900	H 925	H 1025	H 1075	H 1100	H 1150	H 1150-M
Ultimate Tensile Strength - psi	190,000	170,000	155,000	145,000	140,000	135,000	115,000
0.2% Yield Strength - psi	170,000	155,000	145,000	112,000	115,000	105,000	75,000
Elongation, % in 2" or 4 x D	6.0	7.0	8.0	9.0	10.0	11.0	14.0
Reduction of Area - %	15.0	20.0	27.0	28.0	29.0	30.0	35.0
Brinell	388/448	375/438	331/401	302/375	311/364	277/352	255/293
Rockwell	C 40/47	C 38/45	C 35/42	C 31/39	C 32/38	C 28/37	C 24/30
Impact, Charpy V-Notch, ft-lbs Intermediate Location	*	*	10	15	15	20	35

*Minimum impact properties cannot be accepted in this condition.

(1) Transverse mechanical properties are not guaranteed on grade 17-4 PH unless ordered as VAR quality.

**TYPICAL ROOM TEMPERATURE LONGITUDINAL
MECHANICAL PROPERTIES OF REPUBLIC 17-4 PH AND 15-5 PH**

Property	Condition A	Condition H 900	Condition H 925	Condition H 1025	Condition H 1075	Condition H 1100	Condition H 1150	Condition H 1150-M
Ultimate Tensile Strength, psi	150,000	200,000	190,000	170,000	165,000	150,000	145,000	125,000
Yield (0.2%) Strength, psi Tension	110,000	185,000	175,000	165,000	150,000	135,000	125,000	85,000
Elongation in 2", %	10	14	14	15	16	17	19	22
Reduction in Area, %	45	50	54	56	58	58	60	68
Hardness								
Rockwell C	—	44	42	38	36	34	33	27
Brinell	332	420	409	352	341	332	311	277
Impact Strength								
Charpy V-Notch, ft. lbs.	—	20	25	35	40	45	50	100
Fatigue Strength, psi								
10 x 10 ⁶ Cycles	—	90,000	85,000	—	80,000	—	75,000	—
100 x 10 ⁶ Cycles	—	80,000	—	—	—	—	—	—
Torsional Ultimate Strength, psi	—	—	—	—	—	—	125,000	—
Torsional Elastic Limit, psi	—	—	—	—	—	—	52,000	—

**TYPICAL ROOM TEMPERATURE TRANSVERSE
MECHANICAL PROPERTIES OF REPUBLIC 15-5 PH**

Property	Condition A	Condition H 900	Condition H 925	Condition H 1025	Condition H 1075	Condition H 1100	Condition H 1150	Condition H 1150-M
Ultimate Tensile Strength, psi	150,000	200,000	190,000	170,000	165,000	150,000	145,000	125,000
Yield (0.2%) Strength, psi Tension	110,000	185,000	175,000	165,000	150,000	135,000	125,000	85,000
Elongation in 2", %	10	10	11	12	13	14	15	18
Reduction in Area, %	45	30	35	42	43	44	45	50
Hardness								
Rockwell C	—	44	42	38	36	34	33	27
Brinell	332	420	409	352	341	332	311	277
Impact Strength								
Charpy V-Notch, ft. lbs.*	—	8	12	25	25	25	45	—
Fatigue Strength, psi								
10 x 10 ⁶ Cycles	—	90,000	85,000	—	80,000	—	75,000	—
100 x 10 ⁶ Cycles	—	80,000	—	—	—	—	—	—
Torsional Ultimate Strength, psi	—	—	—	—	—	—	125,000	—
Torsional Elastic Limit, psi	—	—	—	—	—	—	52,000	—

*Notch axis transverse — Intermediate location.

TYPICAL ELEVATED TEMPERATURE LONGITUDINAL MECHANICAL PROPERTIES OF REPUBLIC 17-4 PH AND 15-5 PH

STRESS-RUPTURE PROPERTIES in Conditions H 900 and H 1075

Stress to Rupture in 100 hrs.	Properties at Temperature					
	625° F		700° F		800° F	
	H 900	H 1075	H 900	H 1075	H 900	H 1075
Stress, psi	162,000*	137,000	156,000	126,000	140,000	108,000
Elongation, % in 2 in.	3.0	3.5	3.0	4.0	4.0	6.0
Reduction of area, %	7.0	14.5	7.0	15.5	8.0	16.0
Stress to Rupture in 1000 hrs.						
Stress, psi	157,000*	134,000	150,000	123,000	128,000	103,000
Elongation, % in 2 in.	2.0	3.0	2.0	3.5	4.0	5.5
Reduction of area, %	6.0	14.0	6.0	15.0	6.0	15.0

*Extrapolated from 600° to 900° F data.

Republic 17-4 PH and 15-5 PH retain a high proportion of their strength at temperatures up to 900° F. Typical short-time properties are shown on Page 10. For service temperatures in excess of 600° F., the creep and stress rupture strength may be a major design factor.

CREEP STRENGTH in Condition H 900

Stress, psi, for Creep Rate of	Temperature			
	600° F	700° F	800° F	900° F
0.1% in 1000 hrs.	135,000	105,000	60,000	23,000
0.01% in 1000 hrs.	125,000	100,000	43,000	—

LOW TEMPERATURE PROPERTIES OF REPUBLIC 17-4 PH AND 15-5 PH

Republic 17-4 PH and 15-5 PH maintain good ductility at low temperatures. No general statement can be made regarding preferred heat treatments for low temperature applications because much depends on design requirements. However, the following low temperature limits are suggested:

- H 900 If toughness is a design criterion, this heat treatment should be used with caution, regardless of temperature.
- H 925 Down to 0° F for general use. For non-impact applications, useful at temperatures as low as -320° F (for example, valve seats).
- H 1150 Down to -110° F. Design with caution when bar diameters exceed 1" rd.
- H 1150-M Down to -320° F.

For critical cryogenic applications, Republic 15-5 PH should be given preference over 17-4 PH because its impact toughness is generally higher than the following properties:

Comparison of Low Temperature Impact Strengths of 17-4 PH in Various Conditions

Test Temperature, Degrees F	Impact Strength, ft.-lbs.				
	H 925	H 1025	H 1150	H 1150-M	
75	30	75	95	105	95
10	16	58	93	—	85
-40	9	40	76	—	75
-110	5.5	15	48	—	65
-175	—	—	—	—	35
-250	—	—	—	—	18
-320	3.5	4.5	6.5	28	5

*Test samples from 1" Round Bar—Longitudinal Direction
**Test samples from 4" Round Bar—Longitudinal Direction

Typical Mechanical Properties of 17-4 PH at Low Temperatures (Condition H 1100)

Test Temp F	UTS psi	0.2% YS psi	Elongation % in 2"
75	150,000	135,000	17.0
32	193,000	183,000	16.0
-40	203,000	189,500	15.5
-80	209,000	196,000	15.0
-320	248,000	243,000	8.0

**TYPICAL ELEVATED TEMPERATURE PROPERTIES
REPUBLIC 17-4 PH AND 15-5 PH
CONDITION H 900* AND H 1025**
(Short Time Longitudinal Mechanical Properties)

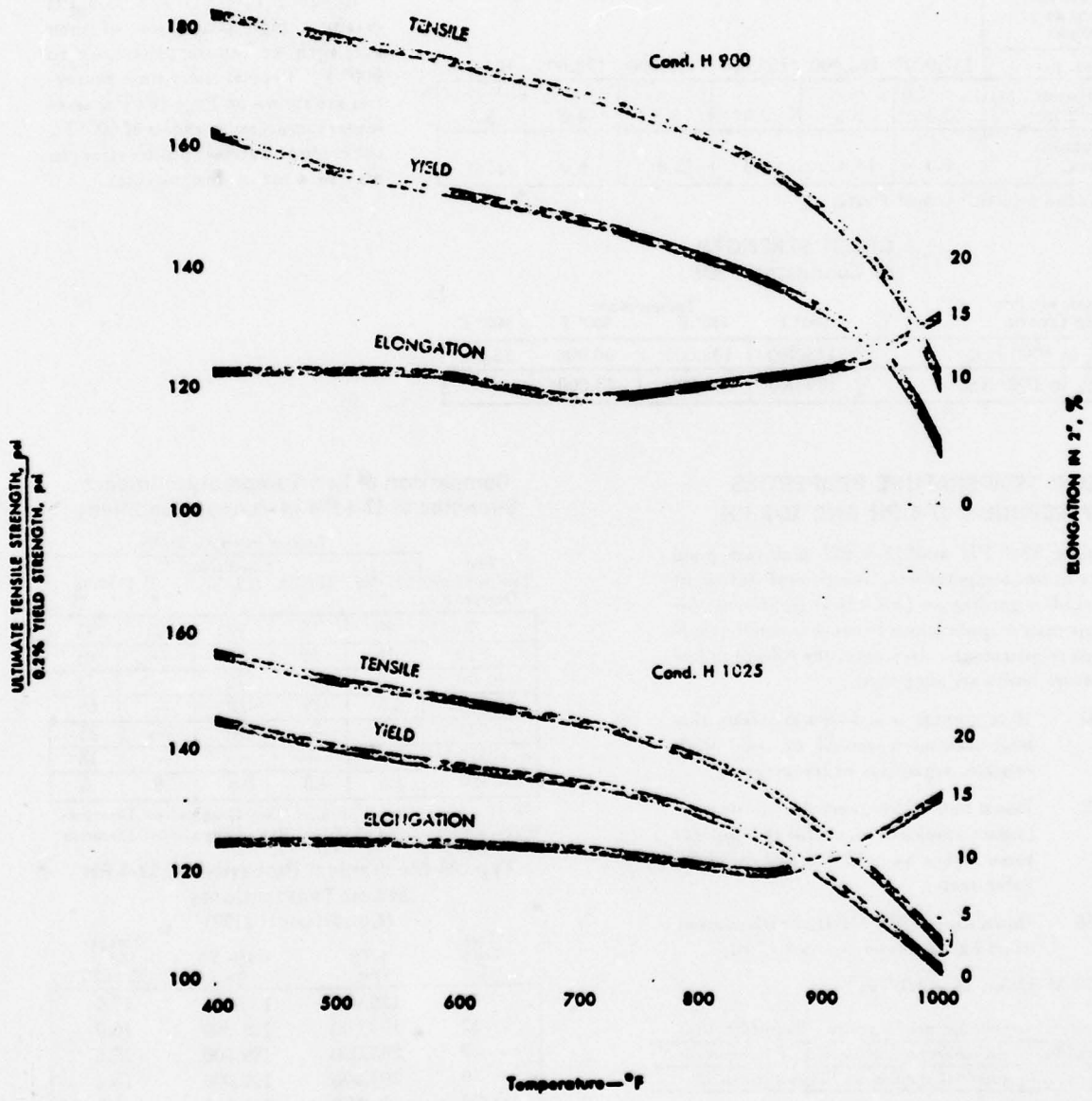

**TYPICAL ROOM TEMPERATURE PROPERTIES
VACUUM ARC REMELTED
REPUBLIC 15-5 PH**

VARIOUS CONDITIONS
25 in. Round Full Section Transverse Tests
(Heat Treated as coupons)

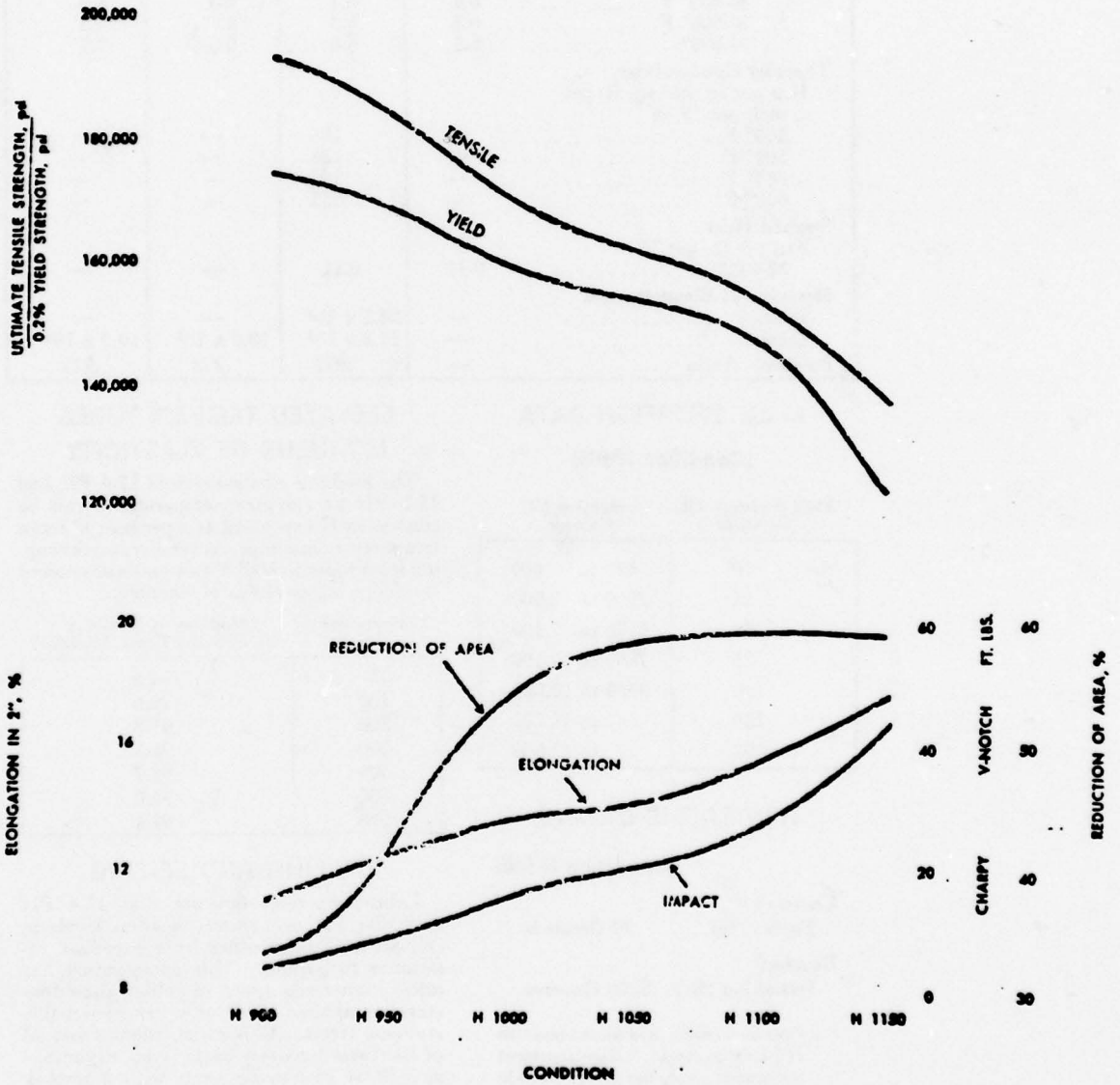

PHYSICAL PROPERTIES OF REPUBLIC 17-4 PH AND 15-5 PH

	Condition A (Magnetic)	Condition H 900 (Magnetic)	Condition H 1075 (Magnetic)	Condition H 1150 (Magnetic)
Density, grams per cu. cm.....	7.78	7.80	7.81	7.82
lbs. per cu. inch.....	0.280	0.282	0.283	0.284
Electrical Resistivity, microhm-cm	98	77	—	—
Magnetic Permeability at				
100 oersteds.....	74	90	88	59
at 200 oersteds.....	48	56	52	38
Maximum.....	95	135	136	71
Mean Coefficient of Thermal Expansion				
10 ⁻⁶ inches per inch per °F..				
—100 to 70° F.....	—	5.8	—	6.1
70-200° F.....	6.0	6.0	6.3	6.6
70-400° F.....	6.0	6.1	6.5	6.9
70-600° F.....	6.2	6.3	6.6	7.1
70-800° F.....	6.3	6.5	6.8	7.2
Thermal Conductivity				
Btu per hr. per sq. ft. per inch per °F at				
300° F.....	—	124	—	—
500° F.....	—	135	—	—
860° F.....	—	156	—	—
900° F.....	—	157	—	—
Specific Heat				
Btu per lb. per °F				
32-212°.....	0.11	0.11	—	—
Modulus of Elasticity, psi				
Tension.....	—	28.5 x 10 ⁶	—	—
Torsion.....	—	11.2 x 10 ⁶	10.0 x 10 ⁶	10.0 x 10 ⁶
Poisson's Ratio.....	—	.272	.272	.272

MAGNETIZATION DATA

(Condition H 900)

Field Strength (H) Oersteds	Induction (B) Gausses
10	430 to 600
25	2000 to 2,900
50	6150 to 7,300
75	7850 to 9,100
100	8900 to 10,000
150	.. to 11,200
200	.. to 12,000

HYSTERESIS DATA (1)

(Condition H 900)

Coercive Force (Hc).....29 Oersteds
Residual Induction (Br) .. 5200 Gausses

(1) Obtained from a maximum induction of 10,000 gaussess. Values represent the sample giving the lowest result in magnetization.

ELEVATED TEMPERATURES

MODULUS OF ELASTICITY

The modulus of elasticity of 17-4 PH and 15-5 PH at elevated temperatures can be conveniently expressed as a per cent of room temperature modulus. At temperatures ranging from room to 600° F this material showed the following modulus of elasticity.

Temperature ° F	Modulus of Elasticity (% of Room Temp. Modulus)
72	100.0
100	99.6
200	97.8
300	96.3
400	94.7
500	93.0
600	91.4

GALLING AND SEIZING

Laboratory tests indicate that 17-4 PH and 15-5 PH of various hardness levels in contact with each other have excellent resistance to galling. This combination has much higher resistance to galling than 18-8 stainless against itself or other hardenable stainless steels. As is usual, the differential of hardness between parts is an advantage as well as employing parts with a smooth finish.

Comparative Corrosion Resistance of 15-5 PH and 17-4 PH

CORROSION RESISTANCE OF 17-4 PH AND 15-5 PH

The general corrosion resistance of these grades is comparable to Type 304 in most media. In boiling 65% HNO₃ and in 1% HCl, 15-5 PH and 17-4 PH exhibit about the same resistance. In salt fog and chloride pitting solutions, 15-5 PH exhibits somewhat superior resistance as shown by these data:

Republic 17-4 PH, 15-5 PH have the greatest degree of resistance to stress-corrosion cracking when heat treated at the highest aging temperature (1100° F being preferred).

Boiling 65% HNO₃—Avg. of 5 48-Hr Periods

Condition	15-5 PH	17-4 PH
H 900	.0083 IPM	.014 IPM
H 1025	.0106 IPM	.007 IPM
H 1150	.0083 IPM	.0065 IPM

1% HCL at 95° F Avg. of 5 48-Hr Periods

Condition	15-5 PH	17-4 PH
H 900	.025 IPY	.035 IPY
H 1025	.085 IPY	.174 IPY
H 1150	.730 IPY	.650 IPY

Commercial Bleach—7 Days at 95° F

Condition	15-5 PH	17-4 PH
H 900	.0016 in.	.03 in.
H 1025	.013 in.	.03 in.
H 1150	.0083 in.	.03 in.

5% Salt Fog at 95° F—10 Days

Condition	15-5 PH	17-4 PH
H 900	0% rust	5-10% rust
H 1025	0-5% rust	10-25% rust
H 1150	0-5% rust	5-10% rust

**Comparative Corrosion Rates*—Laboratory Tests
(Mils, .001", per year)**

Stainless Steel (Base)	Condition	Corrosion Rate in Specific Media—(mils per year)					
		Sulfuric Acid 1% at 35° C	Hydrochloric Acid 0.5% at 35° C	Nitric Acid 25% Boiling	Acetic Acid 60% Boiling	Sodium Hydroxide 50% Boiling	Phosphoric Acid 80% Boiling
Type 431	Hardened and stress relieved	520-820	500-780	8.4-9.6	5.2-5.8	91-96	6-11.3
Type 304	Annealed	28	33	2	—	68	2
17-4 PH	H 925	0.0-0.3	1.7-3.3	7.1-21.8	0.8-2.0	4.9-9.8	0.8-1.2
	H 1025	0.0-0.1	1.6-2.1	5.8-6.4	0.7-1.2	5.0-10.1	0.5-1.2

*These data were obtained in laboratory tests and only indicate the relative corrosion resistance of the materials tested under specific conditions. They should not be used to evaluate expected performance in service.

PROCESS ANNEALING, HEAT TREATING AND DESCALING

When 17-4 PH or 15-5 PH is purchased in the solution treated condition and fabricated by machining or other room temperature systems, only the simple, low temperature (900 to 1150° F) precipitation hardening heat treatment is required. A transparent "heat-tint" type of scale is formed which, if necessary, can be removed by dipping in a 10% nitric-2% hydrofluoric (by volume) acid solution at 110 to 140° F.

If the material is hot worked, such as by forging, however, it should be re-solution treated prior to aging. This is performed by holding at 1900° F \pm 25° F for one hour, separated for air cooling to room temperature, then quenched into cool running water (below 80° F) to insure uniform response to heat treatment. Descaling is then accomplished by grit blasting and/or pickling in 10% nitric-2% hydrofluoric acid (by volume) solution at 110 to 140° F, similar to other stainless grades.

The use of fused salts as pickling aids is normally avoided as they frequently operate near the precipitation hardening temperatures of this grade. However, if machining

MACHINING

Republic 17-4 PH and 15-5 PH can be readily machined in both the solution-treated and various precipitation hardened conditions. Surface finish is very good and close tolerances can be held. However, the machinability, particularly machining speeds and feeds, varies with the heat treat condition.

Normally, these grades are machined in the solution-treated condition (Condition A) to final dimensions because then, only the simple low temperature aging treatment is required to produce the desired combination of mechanical properties.

Machinability in the fully heat

after solution treating is not required, the controlled use of fused salt pickling aids at the precipitation hardening temperature could be concurrently used to accomplish the precipitation hardening heat treatment.

If a fused salt pickling aid is used subsequent to a normal completed heat treating cycle, however, its operating temperature must not exceed the precipitation hardening temperature because the strength of the steel will be impaired.

DIMENSIONAL CHANGES

When Republic 17-4 PH or 15-5 PH is heat treated from Condition A to any of the hardened conditions, a dimensional contraction of 0.0004" - 0.0006" per inch occurs.

Because of its better forgeability, Republic 15-5 PH is recommended over 17-4 PH. Forging billets of either grade should be supplied in the overaged condition to eliminate the possibility of cracking due to thermal or other stresses. Heating practices are similar to those of the other hardenable stainless grades except that an effort must be made to heat fairly rapidly through the 1750 to 1850° F temperature range. Similarly, an attempt should be made not to hot work the steel at

treated condition varies, of course, with the hardness (controlled by the aging temperature). While the machinability of product in Condition H-900 is limited, hard in one of the lower strength conditions (Condition H-1100 or H-1150) will machine even better than those in Condition A.

Where optimum machinability is needed, Republic 17-4 PH and 15-5 PH can be supplied in fully heat treated Condition H-1150M. Although the mechanical properties in this condition are slightly lower than in Condition H-1150, the machinability is noticeably improved.

The relative machinability on automatics in the various conditions is as follows:

temperatures below 1850° F. The reason is that copper tends to precipitate in this range, thereby possibly causing forging and heat treating difficulties. The recommended initial forging temperature range is 2150 to 2200° F. After forging, the parts must be separated for uniform air cooling to room temperature.

WELDING

Although 17-4 PH and 15-5 PH are hardenable stainless steels, their metallurgical structure and method of hardening eliminate the welding problems encountered with regular hardenable stainless steels. Standard production methods are used to fusion or resistance weld.

Sound welds are easily made by any of the arc and resistance processes used for stainless. Welding procedures are essentially the same as those used for the chromium-nickel types. No preheating is required because the very low carbon content of the alloy restricts the hardness of rapidly-cooled metal and prevents the formation of cracks in the weld metal and heat-affected zone of the base metal.

Excellent weld efficiencies are obtained in 17-4 PH and 15-5 PH weldments. Properties in the weld, comparable to those of the parent metal, can be obtained by suitable postweld heat treatment.

Condition H-900	Cutting Rate 20/30 SFPM
Condition A	Cutting Rate 70/80 SFPM
Condition H-1100	Cutting Rate 80/90 SFPM
Condition H-1150M	Cutting Rate 100/130 SFPM

In any of the various conditions it is absolutely essential that the heaviest equipment available in good mechanical condition be used to minimize vibration and chatter. Turning tools should be used wherever possible, instead of form tools. Oil is the preferred coolant and carbide tools should be used where possible instead of high speed tools.

APPENDIX F

ARMCO DATA - 15-5 PH VAC CE

Selection of the stainless steel for the transducer body was partially made using information provided by Armco Steel Corporation. This information is printed here through permission granted by Armco Steel provided in the letter appearing on the following page.

ARMCO INC.

GENERAL OFFICES • MIDDLETOWN, OHIO 45043

ADVERTISING AND
CREATIVE SERVICES

April 17, 1979

Mr. R. E. Thompson
Research Engineer
Chemical Systems Division of
UNITED TECHNOLOGIES
Box 358
Sunnyvale, California 94088

Dear Mr. Thompson:

Thank you for your April 11 letter explaining your desire to publish Armco data in a forthcoming technical report.

You are hereby granted permission to publish the bulletin and data comparing 17-4 PH and 15-5 PH for the purpose described in your letter.

Cordially,

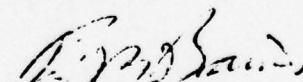

E. M. Rains
Advertising Group Manager

/a

Armco 15-5 PH VAC CE Precipitation-Hardening Stainless Steel Bar, Wire and Forging Billets

Armco 15-5 PH VAC CE is a precipitation-hardening stainless steel that offers a unique combination of high strength and hardness, excellent corrosion resistance plus excellent transverse toughness and good forgeability.

Armco 15-5 PH stainless is produced by consumable electrode vacuum arc remelting (designated VAC CE). Armco 15-5 PH VAC CE stainless steel is virtually "ferrite free." Consequently, it has good transverse notch-toughness and forgeability. In severe upset forging or hot flattening operations where splitting or rupturing are encountered with high strength steels, Armco 15-5 PH VAC CE stainless offers valuable advantages. Its forgeability is superior to Armco 17-4 PH stainless steel.

Fabrication practices for Armco 15-5 PH VAC CE stainless are generally the same as those established for Armco 17-4 PH stainless steel. Most techniques are similar to those recommended for the regular grades of stainless steel. Hardening heat treatments require temperatures of only 900 F (482 C) to 1150 F (621 C), depending on the properties desired. As a result, scaling and distortion difficulties are virtually eliminated. Armco 15-5 PH VAC CE stainless has good machining properties. Excellent surface finish can be produced with conventional tooling.

The information and data set forth in this Product Data Bulletin are accurate to the best of our knowledge and belief, but are intended for general information only. General and specific applications suggested for the materials described herein are made solely to permit the reader to make his own evaluation and decision, and are not to be construed as either express or implied warranties of fitness for these or other applications. The data reported herein have been developed through tests conducted by or for Armco. They are not guarantees.

Armco, the Armco Triangle, PH 15-7 Mo, 17-4 PH, 15-5 PH and 17-7 PH[®] trademarks of Armco Steel Corporation, Middletown, Ohio

The values shown herein were established in U.S. customary units. The metric equivalents of U.S. customary units shown may be approximate. Conversion to the metric system, known as the International System of Units (SI), has been accomplished in accordance with ASTM Standard E380-72 "Metric Practice Guide."

COMPOSITION

	%
Carbon	0.07 max
Manganese	1.00 max
Phosphorus	0.04 max
Sulfur	0.03 max
Silicon	1.00 max
Chromium	14.00-15.50
Nickel	3.50-5.50
Copper	2.50-4.50
Columbium plus Tantalum	0.15-0.45

AVAILABLE FORMS

Armco 15-5 PH VAC CE stainless steel is produced in the form of billets, plate, bar and wire. It is usually supplied in the solution treated Condition A ready for fabrication and subsequent hardening by the user. However, it can be supplied in certain hardened conditions if so desired. Material for forging should be ordered in the overaged condition. Wire for cold heading should be ordered overaged, coated and cold drawn.

Conditions Available from Mill

- 1) Condition A (Solution treated) Material for fabrication and heat treatment by the user. If severe cold forming is required use Condition H 1150 or H 1150-M.
- 2) Condition H 1075 Precipitation-hardened condition. Machines as well as Condition A.
- 3) Condition H 1150 Precipitation-hardened condition. More readily fabricated than Condition A. No further heat treatment necessary where no severe cold working is involved.
- 4) Overaged for forging Allows cold sawing of large sections without cracking.
- 5) Overaged, copper coated and cold drawn for cold heading Maximum softness for cold heading. Materials in this condition will not respond to aging treatments without first solution treating.
- 6) Other Conditions Inquire for availability.

Consumable Electrode Vacuum Arc Remelting (VAC CE)

Armco 15-5 PH VAC CE stainless steel is produced by consumable electrode vacuum arc remelting to meet the stringent mechanical property and cleanliness requirements of the space and nuclear industries. Besides lowering gas content, VAC CE adds other advantages to Armco 15-5 PH VAC CE stainless. It reduces and disperses inclusions, and minimizes alloy segregation during solidification. These factors, coupled with the elimination of delta ferrite, combine to give Armco 15-5 PH VAC CE stainless excellent transverse mechanical properties in any test location.

APPLICATIONS

Armco 15-5 PH VAC CE stainless steel is ideal for applications requiring high strength and toughness in all directions. Typical applications include forgings, pump and valve parts for high pressure systems requiring excellent corrosion resistance, aircraft components and transversely loaded plate applications.

SPECIFICATIONS

Armco 15-5 PH bar, wire, forgings and forging stock is covered by the following specifications. It is suggested that the issuing agency be contacted for the latest revision of the specification.

ASTM A 564 Hot-Finished or Cold-Finished Age Hardening Stainless and Heat-Resisting Steel Bars and Shapes

ASTM A 705 Age Hardening and Heat-Resisting Steel Forgings

AMS 5659 Consumable Electrode Melted Bars, Forgings and Rings

STANDARD HEAT TREATMENTS

Armco 15-5 PH VAC CE stainless steel can be heat treated at different temperatures to develop a wide range of properties. Fully hardened 15-5 PH VAC CE stainless, Condition H 900, will have a minimum ultimate tensile strength of 190,000 psi (1310 MPa) and minimum yield strength of 170,000 psi (1172 MPa). Typical properties for the standard conditions are shown in Tables IV and V.

15-5 PH VAC CE HEAT TREATMENTS

Condition A
Solution Treated
1900 F \pm 25 F 1/2 Hr.
(1036 C \pm 14 C)
Oil or Air Cool

Condition	Heat to \pm 15 F (\pm 9 C)	Hold for Hours	Cool
H 900	900 F (482 C)	1	Air
H 925	925 F (495 C)	4	Air
H 1025	1025 F (552 C)	4	Air
H 1075	1075 F (579 C)	4	Air
H 1100	1100 F (593 C)	4	Air
H 1150	1150 F (621 C)	4	Air
H 1150-M (Double Overaged)	1400 F (760 C)	2	Air
	1150 F (621 C)	4	Air

Armco 15-5 PH VAC CE stainless exhibits useful mechanical properties in Condition A, and tests in progress at Kure Beach for more than two years show excellent stress corrosion cracking resistance. Condition A material can be used successfully in numerous applications.

However, in critical applications, Armco 15-5 PH VAC CE stainless should be used in the precipitation-hardened condition, rather than Condition A. Heat treating to the hardened condition, especially at the higher end of the temperature range, stress relieves the structure and provides more reliable resistance to stress corrosion cracking than in Condition A.

In applications where the use of 15-5 PH VAC CE stainless in Condition A is being considered, it is suggested that Armco be contacted for technical assistance.

Heat-Treating Cycle Forging and Cold Heading

If 15-5 PH VAC CE stainless is to be forged or cold headed, it is supplied "overaged for forging" or "overaged for cold heading." Overaging consists of heat treatment at the mill in the temperature range of 1150 to 1200 F (621 to 648 C) to achieve maximum softness for cold sawing and cold heading. Such treatment eliminates the possibility of cracking in large sections. Material in this condition will not respond to hardening treatments without first solution treating.

MECHANICAL PROPERTIES

The newton (N) has been adopted by the SI as the metric standard unit of force as discussed in ASTM Standard E380-72. The term for force per unit of area (stress) is the newton per square meter (N/m^2). Since this can be a large number, the prefix mega is used to indicate 1,000,000 units and the term meganewton per square meter (MN/m^2) is used. The unit (N/m^2) has been designated a pascal (Pa). The relationship between the U.S. and the SI units for stress is: 1000 pounds/in² (psi) = 1 kip/in² (ksi) = 6.8948 meganewtons/m² (MN/m^2) = 6.8948 megapascals (MPa).

Orientation and Location of Test Specimens

Armco 15-5 PH VAC CE stainless is needed in many applications requiring excellent mechanical properties in the long transverse and short transverse directions, as well as in the longitudinal direction (direction of rolling). Orientation and location of the test specimen and product section size are receiving more emphasis in the determination of design values. The data included in this bulletin are identified regarding (1) orientation of specimen, (2) specimen location, and (3) section size from which the test specimens were taken. Orientation and location of test specimens are shown in the following sketches. Unless otherwise stated, data represents longitudinal direction — intermediate location.

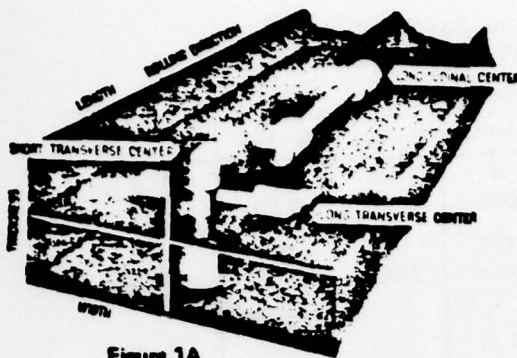

Figure 1A

Sketches showing the orientation and location of test specimens in a typical bar section. Fig. 1A shows specimens located at the center or along the axes of the respective bar dimensions. Fig. 1B illustrates the location of test specimens to determine properties at intermediate locations.

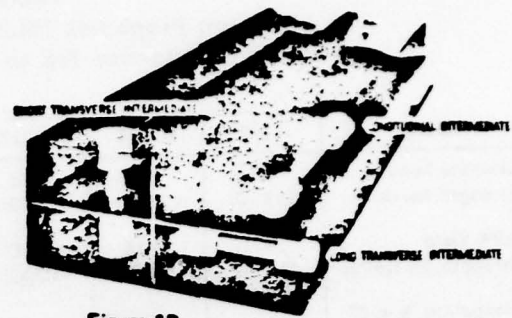

Figure 1B

(1) Transverse properties cannot be determined if bar dimensions are under 3" (76.2 mm) in the test direction.

(2) In rounds, squares, and hexagon bars, no short transverse direction exists.

PROPERTIES ACCEPTABLE FOR MATERIAL SPECIFICATIONS

Table I
Maximum Hardness or Tensile Strength in Condition A

Rounds, Hexagons and Squares			Flats
1/8" (3.18 mm) and Smaller	Over 1/8" to 1/2" Incl (3.18 mm to 12.7 mm Incl)	Over 1/2" (12.7 mm)	Over 1/2" (12.7 mm)
175,000 psi (1207 MPa) max	R _C 38 max	BHN 363 max	BHN 363

Table II
Minimum Properties (Suitable for Specifications)
Longitudinal Direction — Intermediate Location (up to 12" [304.8 mm] section)

	Condition						
	H 900	H 925	H 1025	H 1075	H 1100	H 1150	H 1150-M
Ultimate Tensile Strength, ksi (MPa)	190 (1310)	170 (1172)	155 (1069)	145 (1000)	140 (965)	135 (931)	115 (793)
0.2% Yield Strength, ksi (MPa)	170 (1172)	155 (1069)	145 (1000)	125 (862)	115 (793)	105 (724)	75 (517)
Elongation, % in 2" (50.8 mm) or 4 x D	10.0	10.0	12.0	13.0	14.0	16.0	18.0
Reduction of Area, %	35.0	38.0	45.0	45.0	45.0	50.0	55.0
Hardness							
Brinell	388/448	375/438	331/401	302/375	311/364	277/352	255/293
Rockwell	C40/47	C38/45	C35/42	C31/39	C32/38	C28/37	C24/30
Impact, Charpy V-Notch, ft-lbs (J)	•	5 (6.8)	15 (20)	20 (27)	25 (34)	30 (41)	55 (75)

Table II.
Minimum Properties (Suitable for Specifications)
Transverse Direction (up to 12" [304.8 mm] section)

Property	Condition						
	H 900	H 925	H 1025	H 1075	H 1100	H 1150	H 1150-M
Ultimate Tensile Strength, ksi (MPa)	190 (1310)	170 (1172)	155 (1069)	145 (1000)	140 (965)	135 (931)	115 (793)
0.2% Yield Strength, ksi (MPa)	170 (1172)	155 (1069)	145 (1000)	125 (862)	115 (793)	105 (724)	75 (517)
Elongation, % in 2" (50.8 mm) or 4 x D	6.0	7.0	8.0	9.0	10.0	11.0	14.0
Reduction of Area, %	15.0	20.0	27.0	28.0	29.0	30.0	35.0
Hardness							
Brinell	388/448	375/438	331/401	302/375	311/364	277/352	255/293
Rockwell	C40/47	C38/45	C35/42	C31/39	C32/38	C28/37	C24/30
Impact, Charpy V-Notch, ft-lbs (J) Intermediate Location			10 (14)	15 (20)	15 (20)	20 (27)	35 (47)

* Minimum impact properties cannot be accepted in this condition if toughness is a design criteria, this heat treatment should be used with caution.

Typical Properties

Table IV
Typical Mechanical Properties**
Longitudinal Direction — Intermediate Location

Property	Condition						
	H 900	H 925	H 1025	H 1075	H 1100	H 1150	H 1150-M
Ultimate Tensile Strength, ksi (MPa)	200 (1379)	190 (1310)	170 (1172)	165 (1138)	150 (1034)	145 (1000)	125 (862)
0.2% Yield Strength, ksi (MPa)	185* (1276)	175 (1207)	165 (1138)	150 (1034)	135 (931)	125 (862)	85 (586)
Elongation, % in 2" (50.8 mm) or 4 x D	14.0	14.0	15.0	16.0	17.0	19.0	22.0
Reduction of Area, %	50.0	54.0	56.0	58.0	58.0	60.0	68.0
Hardness							
Brinell	420	409	352	341	332	311	277
Rockwell	C44	C42	C38	C36	C34	C33	C27
Impact, Charpy V-Notch, ft-lbs (J)	15 (20)	25 (34)	35 (47)	40 (54)	45 (61)	50 (68)	100 (136)

* Compressive yield strength for Condition H 900 is 178,000 psi (1227 MPa)

** Typical data represent average values of qualification tests for production orders

Table V
Typical Mechanical Properties**
Transverse Direction — Intermediate and Center Location

Property	Condition													
	H 900		H 925		H 1025		H 1075		H 1100		H 1150		H 1150-M	
	I*	C*	I*	C*	I*	C*	I*	C*	I*	C*	I*	C*	I*	C*
Ultimate Tensile Strength, ksi (MPa)	200 (1379)	200 (1379)	190 (1310)	190 (1310)	170 (1172)	170 (1172)	165 (1138)	165 (1138)	150 (1034)	150 (1034)	145 (1000)	145 (1000)	125 (862)	125 (862)
0.2% Yield Strength, ksi (MPa)	185 (1276)	185 (1276)	175 (1207)	175 (1207)	165 (1138)	165 (1138)	160 (1034)	160 (1034)	135 (931)	135 (931)	125 (862)	125 (862)	85 (586)	85 (586)
Elongation, % in 2" (50.8 mm) or 4 x D	10.0	10.0	11.0	11.0	12.0	12.0	13.0	13.0	14.0	14.0	15.0	15.0	18.0	18.0
Reduction of Area, %	30.0	30.0	35.0	35.0	42.0	42.0	43.0	43.0	44.0	44.0	45.0	45.0	50.0	50.0
Hardness Brinell Rockwell	420 C44	420 C44	409 C42	409 C42	352 C38	352 C38	341 C36	341 C36	332 C34	332 C34	311 C33	311 C33	277 C27	277 C27
Impact Charpy V-Notch, ft-lbs (J)														
Notch Axis Longitudinal	7 (9.5)		17 (23)		27 (37)		30 (41)		30 (41)		50 (68)		100 (136)	
Notch Axis Transverse	8 (11)		12 (16)		25 (34)		25 (34)		25 (34)		45 (61)		70 (95)	

*I — Intermediate Location C — Center Location
 ** — Typical data represent average values of qualification tests for production orders.

Shear Strength

Table VI
Shear Strength In Double Shear

Condition	UTS ksi (MPa)	Shear Strength ksi (MPa)	Shear/Tensile Ratio %
H 900	205.6 (1418)	124.0 (855)	60.7
H 925	189.1 (1304)	116.0 (800)	61.8
H 1025	164.7 (1136)	104.2 (718)	63.2
H 1100	154.7 (1067)	99.1 (683)	63.0
H 1150-M	134.9 (930)	89.3 (616)	66.2

* Data developed on 1/4" (6.35 mm) round wire. Average of five tests on one heat.

Table VII
Fatigue Strength — Unnotched*
Tension — Tension

Maximum Stress. ksi (MPa)	Cycles to Failure**		
	Condition A	Condition H 1025	Condition H 1100
160.0 (1103)	—	32,900	—
155.0 (1069)	—	322,800	—
150.0 (1034)	—	38,800	55,100
150.0 (1034)	—	99,200	—
140.0 (965)	61,200	125,600	95,000
140.0 (965)	—	358,600	—
137.5 (948)	—	—	96,100
137.5 (948)	—	—	97,400
135.0 (931)	—	80,700	3,896,000
135.0 (931)	—	162,600	7,096,000
135.0 (931)	—	2,032,000	—
132.5 (914)	—	—	127,100
132.5 (914)	—	—	219,900
130.0 (896)	190,400	118,700	4,860,000
130.0 (896)	—	6,044,800	—
130.0 (896)	—	8,720,100	—
127.5 (879)	—	—	7,300,000
125.0 (862)	224,400	—	3,907,000
125.0 (862)	—	—	6,031,000
120.0 (827)	214,900	—	—
115.0 (793)	4,792,000 (Discontinued)	—	—
110.0 (758)	3,433,600 (Discontinued)	—	—
90.0 (621)	5,152,200 (Discontinued)	—	—
90.0 (621)	10,100,000 (Discontinued)	—	—

Table VIII
Fatigue Strength — Notched (k_t = 3.0)
Tension — Tension*

Maximum Stress. ksi (MPa)	Cycles to Failure**		
	Condition A	Condition H 1025	Condition H 1100
65.0 (448)	—	—	107,000
62.5 (431)	—	111,500	—
60.0 (414)	—	105,200	—
60.0 (414)	—	150,400	232,600
57.5 (396)	—	262,200	—
57.5 (396)	—	6,966,400	—
55.0 (379)	—	225,700	332,000
55.0 (379)	—	1,678,300	332,000
55.0 (379)	—	3,004,000	5,529,400
52.5 (362)	—	—	23,300,000 (Discontinued)
52.5 (362)	—	10,164,000 (Discontinued)	10,000,000 (Discontinued)
50.0 (345)	88,200	—	10,017,000 (Discontinued)
50.0 (345)	299,200	—	—
45.0 (310)	350,000	—	—
45.0 (310)	10,826,000 (Discontinued)	—	—
42.5 (293)	255,500	—	—
42.5 (293)	10,110,500 (Discontinued)	—	—
40.0 (276)	10,563,800 (Discontinued)	—	10,200,000 (Discontinued)
40.0 (276)	10,565,000 (Discontinued)	—	—

* Transverse specimens prepared from 2" (51 mm) x 6" (152 mm) hot forged bar.

$$R = \frac{\text{minimum stress}}{\text{maximum stress}} = 0.1, \text{ speed} = 30 \text{ hertz, uniaxial loading}$$

** Data represent individual tests from one heat.

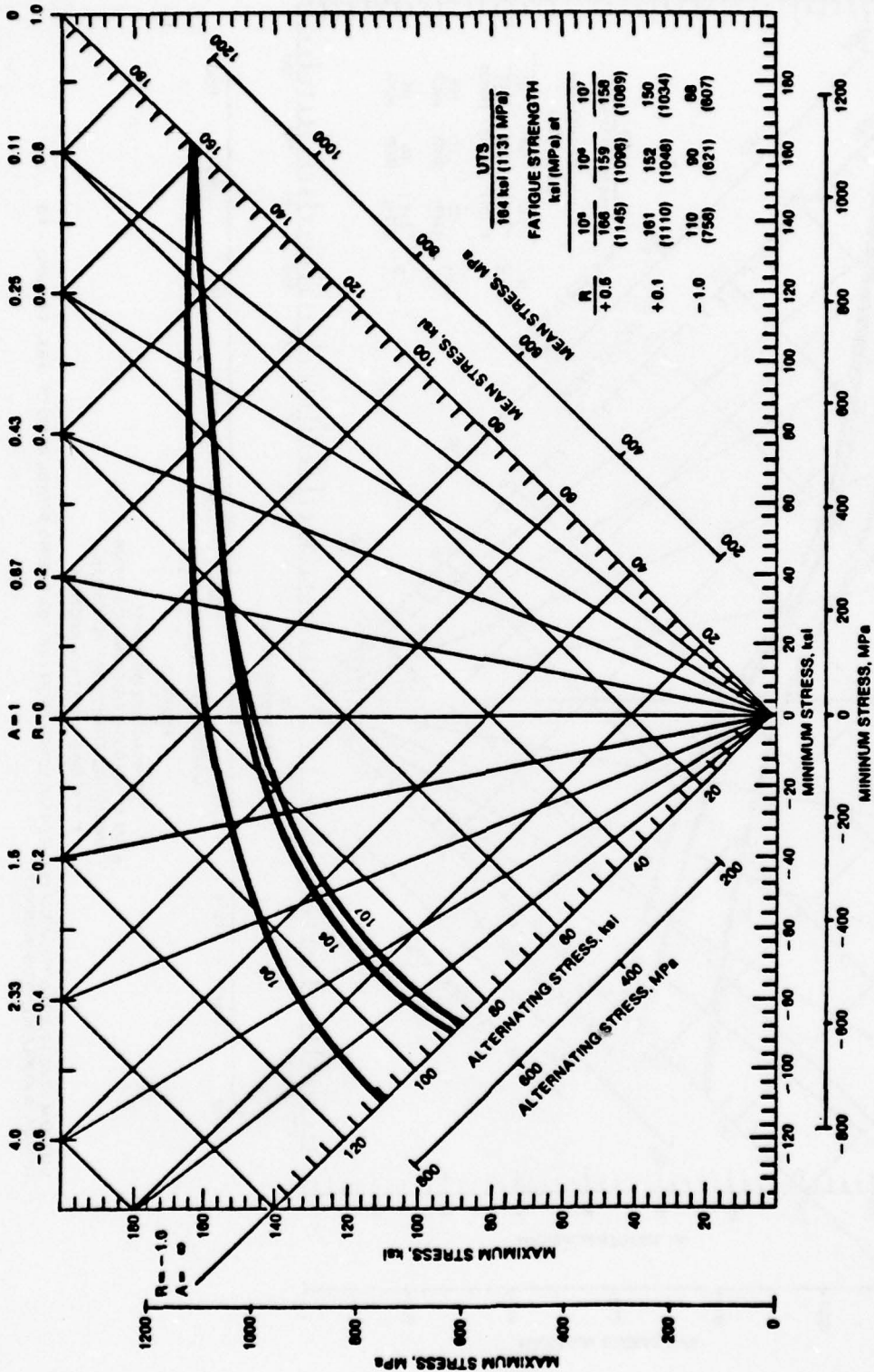

FIGURE 2

CONSTANT LIFE DIAGRAM*
 AXIAL LOADED 15-8 PH, CONDITION H 1025
 UNNOTCHED LONGITUDINAL SPECIMENS
 2" x 6" (50.8 x 152.4 mm) SECTION

*DIAGRAM CONSTRUCTED FROM S-N CURVES DEVELOPED FROM ONE HEAT USING STRESS RATIO OF +0.5, +0.1 AND -1.0.
 RAW DATA AVAILABLE UPON REQUEST.

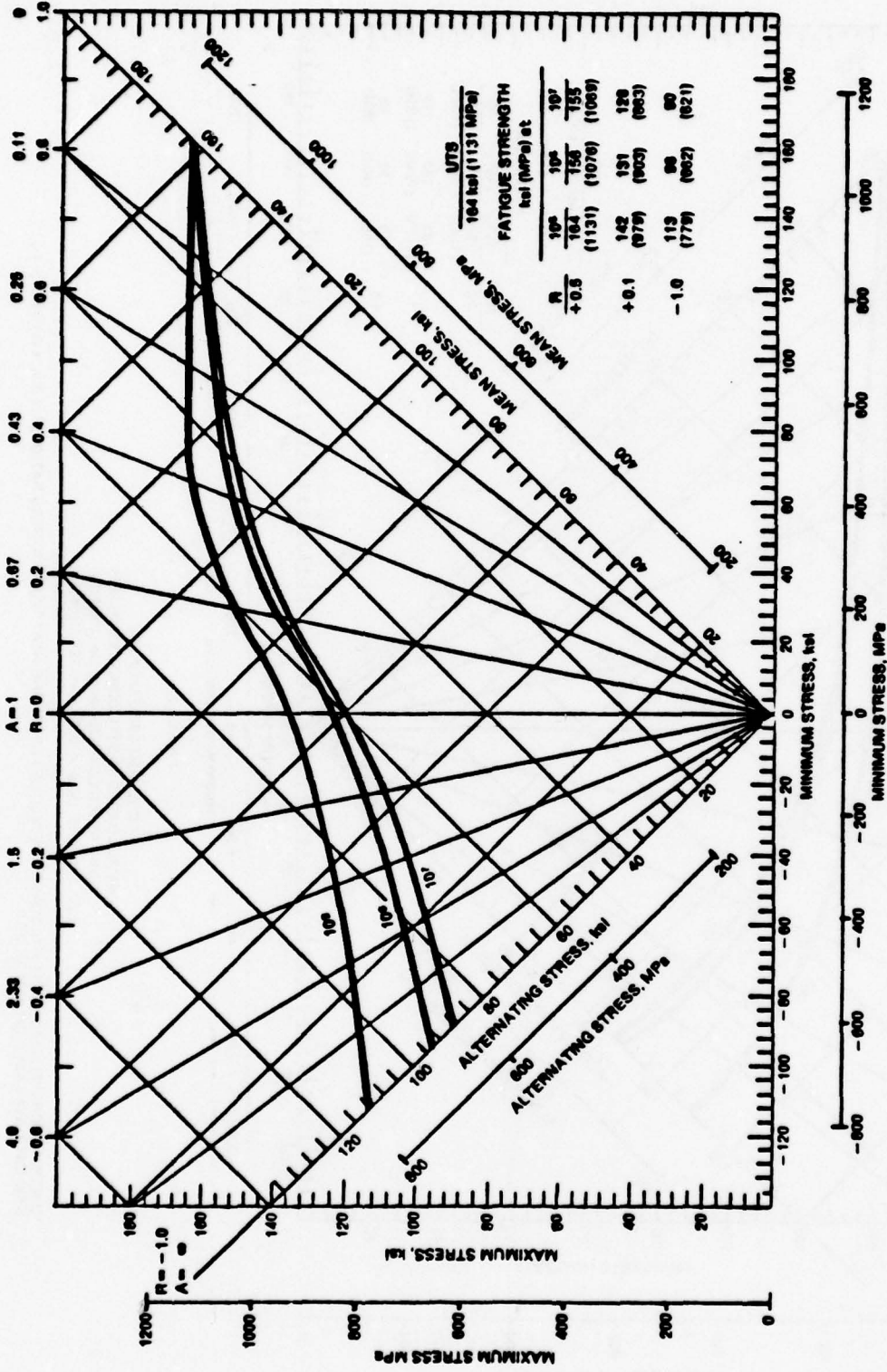

FIGURE 3

CONSTANT LIFE DIAGRAM *
AXIAL LOADED 15-5 PH, CONDITION H 1028
UNNOTCHED TRANSVERSE SPECIMENS
2" x 8" (50.8 x 152.4 mm) SECTION

*DIAGRAM CONSTRUCTED FROM S-N CURVES DEVELOPED FROM ONE HEAT USING STRESS RATIO OF +0.5, +0.1 AND -1.0.
RAW DATA AVAILABLE UPON REQUEST.

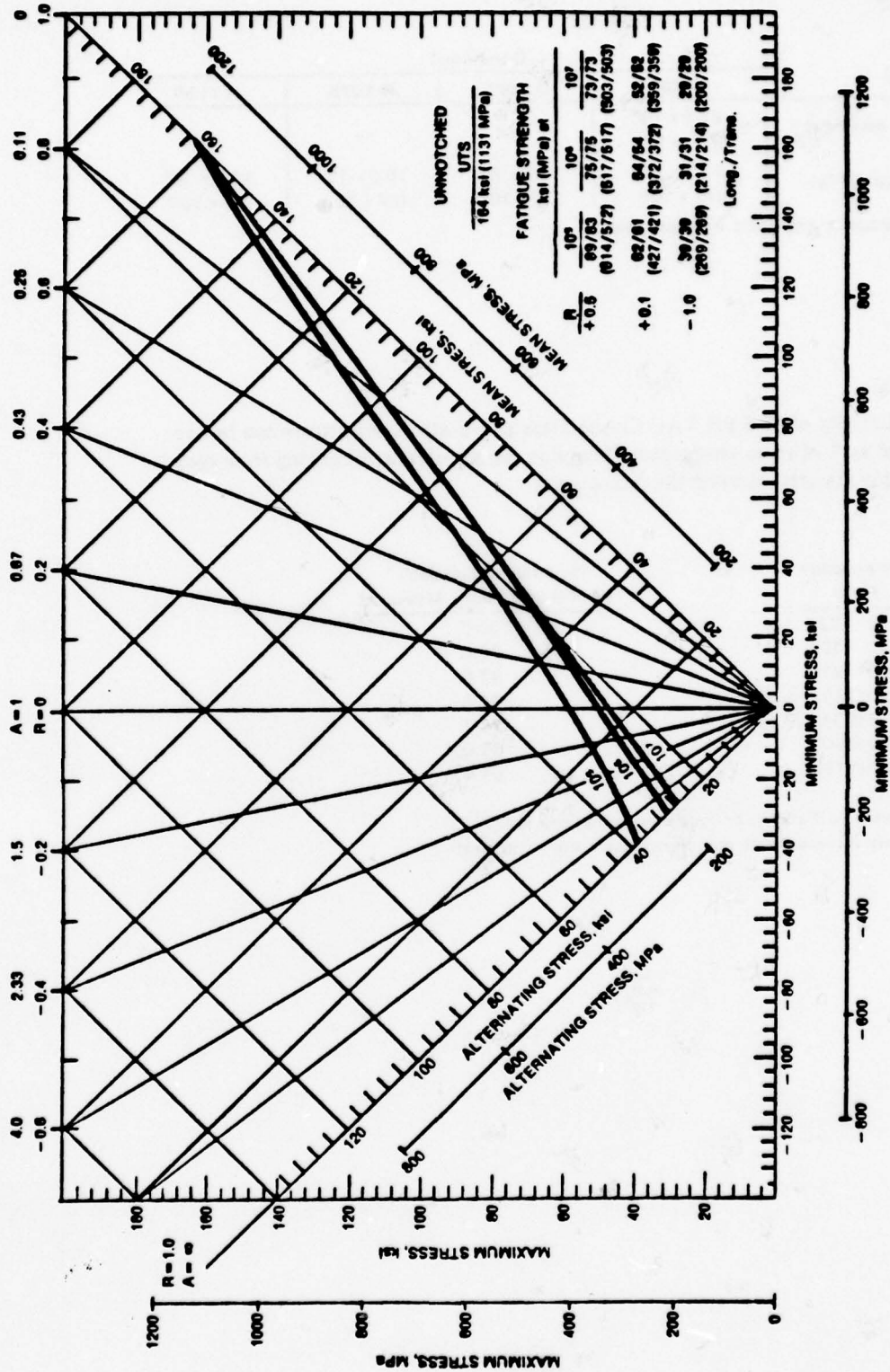

FIGURE 4
 CONSTANT LIFE DIAGRAM
 AXIAL LOADED 15-5 PH, CONDITION H 1025
 NOTCHED ($K_t = 3.0$) LONGITUDINAL AND TRANSVERSE SPECIMENS
 $2' \times 6'$ (50.8 x 152.4 mm) SECTION

*DIAGRAM CONSTRUCTED FROM S-N CURVES DEVELOPED FROM ONE HEAT USING STRESS RATIO OF +0.5, +0.1 AND -1.0
 RAW DATA AVAILABLE UPON REQUEST

Modulus of Elasticity

Table IX

	Condition*			
	H 900	H 1025	H 1075	H 1150
Modulus in Tension, psi (MPa)	28.5 x 10 ⁶ (196 x 10 ³)	—	—	—
Modulus in Torsion, psi (MPa)	11.2 x 10 ⁶ (77 x 10 ³)	11.0 x 10 ⁶ (76 x 10 ³)	10.0 x 10 ⁶ (69 x 10 ³)	10.0 x 10 ⁶ (69 x 10 ³)

*Data represent average of two tests from one heat.

The modulus of elasticity of 15-5 PH VAC CE stainless at elevated temperature can be conveniently expressed as % of room temperature modulus. At temperatures ranging from room to 600 F (315 C) this material showed the following:

Temperature F (C)	Modulus of Elasticity* (% of Room Temp. Modulus)
72 (22)	100.0
100 (38)	99.6
200 (93)	97.8
300 (149)	96.3
400 (204)	94.7
500 (260)	93.0
600 (315)	91.4

Poisson's Ratio in all hardened conditions is 0.272.

*Data represent average of two tests from one heat.

Torsional and Tensile Data

Table X
Torsional and Tensile Data
Armco 15-5 PH VAC CE Stainless Bar Stock*

Condition	Torsional Shear Modulus, ksi (MPa)	Torsional Proportional Limit, ksi (MPa)	0.2% Torsional Yield Strength, ksi (MPa)		Modulus of Rupture, ksi (MPa)	UTS, ksi (MPa)	0.2% YS, Offset, ksi (MPa)	Torsional YS ($\sqrt{\epsilon}$), Tension YS	Torsional YS (ϵ), Tension YS	Modulus of Rupture, UTS
			$\sqrt{\epsilon}$ **	ϵ **						
Annealed	8.85 x 10 ⁶ (89 x 10 ⁶)	62.8 (433)	84.8 (576)	93.5 (644)	120.7 (832)	164.4 (1065)	122.6 (845)	0.89	0.76	0.78
H 900	10.79 x 10 ⁶ (75 x 10 ⁶)	89.3 (616)	117.6 (811)	126.3 (871)	183.7 (1129)	190.1 (1311)	170.2 (1174)	0.89	0.74	0.86
H 925	11.07 x 10 ⁶ (76 x 10 ⁶)	92.3 (636)	114.7 (790)	123.1 (849)	155.6 (1074)	182.0 (1255)	168.3 (1180)	0.88	0.73	0.85
H 1025	10.93 x 10 ⁶ (75 x 10 ⁶)	90.8 (627)	107.7 (743)	114.2 (797)	137.1 (946)	161.0 (1110)	157.3 (1084)	0.88	0.73	0.85
H 1100	10.66 x 10 ⁶ (74 x 10 ⁶)	90.1 (653)	99.0 (683)	105.3 (728)	127.0 (876)	150.0 (1034)	145.2 (1002)	0.88	0.73	0.85
H 1150	10.76 x 10 ⁶ (74 x 10 ⁶)	57.7 (398)	86.2 (594)	93.3 (643)	125.1 (863)	141.8 (977)	128.1 (887)	0.87	0.73	0.88
H 1150-M	9.56 x 10 ⁶ (65 x 10 ⁶)	38.0 (262)	59.4 (409)	67.5 (465)	113.4 (782)	132.0 (910)	90.9 (627)	0.85	0.74	0.86

* Average of two tests from one heat — specimens machined from 1" (25.4 mm) bar stock.

** $\sqrt{\epsilon}$ — Offset determined by shearing strain ($\sqrt{\epsilon}$) = 0.002

ϵ — Offset determined by normal strain (ϵ) = 0.002

Reference: Test Method described in paper, "Mechanical Properties of Shafting and Valve Stem Materials," by John N. Macadam, published in Proceedings of the American Society for Testing and Materials, Vol. 64, page 765

Elevated Temperature Properties

Table XI
Short-Time Tensile Properties*

Property and Condition	Temperature, F (C)					
	75 (24)	400 (204)	600 (315)	800 (426)	1000 (538)	1200 (648)
UTS, ksi (MPa)						
H 925	191 (1317)	168 (1158)	159 (1096)	149 (1027)	110 (758)	58 (400)
H 1025	166 (1145)	147 (1014)	139 (958)	133 (917)	105 (724)	54 (372)
H 1100	155 (1069)	138 (951)	132 (910)	123 (848)	96 (662)	—
H 1150-M	130 (896)	111 (765)	104 (717)	98 (676)	80 (552)	—
0.2% YS, ksi (MPa)						
H 925	176 (1213)	152 (1048)	140 (965)	126 (869)	92 (634)	46 (317)
H 1025	161 (1110)	139 (958)	131 (903)	119 (820)	91 (627)	41 (283)
H 1100	150 (1034)	134 (924)	126 (869)	114 (786)	88 (607)	—
H 1150-M	104 (717)	100 (689)	96 (662)	88 (607)	67 (462)	—
Elong. % in 4 x D						
H 925	16	15	14	15	17	26
H 1025	17	15	14	15	18	28
H 1100	19	16	14	14	18	—
H 1150-M	23	20	19	17	20	—
Reduction of Area, %						
H 925	59	54	59	60	70	83
H 1025	64	58	57	60	70	83
H 1100	67	62	57	60	71	—
H 1150-M	75	64	70	69	74	—

* Data represent average of four tests consisting of duplicate tests on each of two heats — one on 1" (25.4 mm) diameter bar and the other on 1-1/4" (31.8 mm) diameter bar.

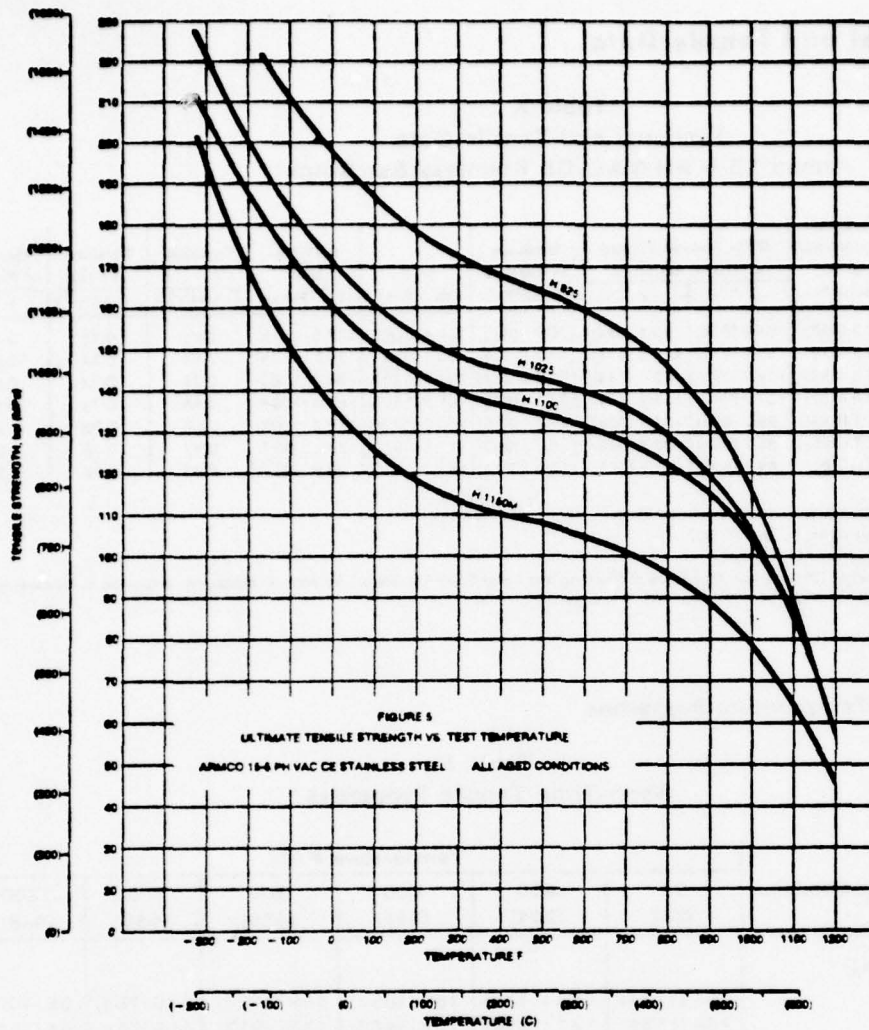

THESE CURVES CONSTRUCTED USING DATA FROM
 DUPLICATE TESTS ON 2 HEATS

Sub-Zero Mechanical Properties

Armco 15-5 PH VAC CE stainless steel maintains good ductility at sub-zero temperatures. This property makes it an ideal material for applications such as valves and aircraft parts that must operate at low temperatures. No general statement can be made regarding preferred heat treatment for cryogenic applications because much depends on design requirements. However, many engineers have approved Armco 15-5 PH VAC CE stainless to the following temperature limits:

- Condition H 925 — Down to 0 F (-18 C) for general use. For non-impact applications it is useful at temperatures as low as -320 F (-196 C). For example, valve seats.
- Condition H 1025 — Down to -50 F (-46 C). Design with caution when using large diameter bars.
- Condition H 1100 — Down to -110 F (-79 C). Design with caution when using large diameter bars.
- Condition H 1150-M — Down to -320 F (-196 C).

Table XII
Short-Time Tensile Properties*

Property and Condition	Temperature, F (C)		
	-320 (-196)	-100 (-73)	75 (23.8)
UTS, ksi (MPa)			
H 925		212 (1462)	191 (1317)
H 1025	226 (1558)	194 (1269)	166 (1145)
H 1100	210 (1448)	172 (1186)	155 (1069)
H 1150-M	201 (1386)	151 (1041)	130 (896)
0.2% YS, ksi (MPa)			
H 925	-	199 (1372)	176 (1213)
H 1025	221 (1524)	179 (1234)	161 (1110)
H 1100	205 (1413)	166 (1145)	150 (1034)
H 1150-M	146 (1007)	107 (738)	104 (717)
Elong. % in 4 x D			
H 925	-	17	16
H 1025	15	18	17
H 1100	18	19	19
H 1150-M	27	25	23
Reduction of Area, %			
H 925	-	61	59
H 1025	55	67	64
H 1100	60	66	67
H 1150-M	65	74	75

* Data represent average of four tests consisting of duplicate tests on each of two heats: one on 1" (25.4 mm) diameter bar and the other on 1-1/4" (31.8 mm) diameter bar.

Table XIII
Impact Strength at Sub-Zero Temperatures*
V-Notch Charpy Impact, Foot-Pounds (J)

Condition	Temperature F (C)				
	75 (23.8)	+10 (-12)	-40 (-40)	-110 (-79)	-320 (-196)
H 925	58 (79)	28 (38)	16 (22)	7 (9)	—
H 1025	84 (114)	46 (62)	23 (31)	9 (12)	2 (2.7)
H 1100	96 (130)	80 (108)	54 (73)	27 (37)	3.5 (4.7)
H 1150-M	174 (236)	172 (233)	167 (226)	152 (206)	33 (45)

* Data represent average of four tests consisting of duplicate tests of two heats: one on 1" (25.4 mm) diameter bar and the other on 1-1/4" (31.8 mm) diameter bar.

Table XIV
Impact Strength at Sub-Zero Temperatures*
Precracked Charpy Impact, in-lbs/in² (mm²N/mm²)

Condition	Temperature F (C)				
	75 (23.8)	+10 (-12)	-40 (-40)	-110 (-79)	-320 (-196)
H 925	2.650 (464)	750 (131)	300 (53)	200 (35)	—
H 1025	5.100 (893)	1.900 (333)	900 (158)	350 (61)	—
H 1100	6.900 (1,208)	4.150 (727)	2.150 (377)	850 (149)	—
H 1150-M	12.250 (2,145)	11,900 (2,084)	11,400 (1,997)	9,900 (1,734)	1,100 (193)

* Data represent average of four tests consisting of duplicate tests of two heats: one on 1" (25.4 mm) diameter bar and the other on 1-1/4" (31.8 mm) diameter bar.

Table XV
Typical Sub-Zero V-Notch Charpy Impact*
6" x 6" (150 mm x 150 mm) Section
Longitudinal — Intermediate
Condition H 1150-M

<u>Test Temperature, F (C)</u>	<u>Charpy V-Notch, ft-lbs (J)</u>
Room	100 (136)
-110 (-79)	75 (102)
-175 (-115)	40 (54)
-320 (-196)	20 (27)

* Data represent average of duplicate tests on one heat.

PHYSICAL PROPERTIES

Table XVI

	Condition*			
	A	H 900	H 1075	H 1150
Density, gm/cm ³	7.78	7.80	7.81	7.82
lbs/in ³	0.281	0.282	0.282	0.283
Electrical Resistivity, microhm-cm	98	77	—	—
Mean Coefficient of Thermal Expansion in/in/°F (μm/m°C)				
-100/70 F (-73/21 C)	—	5.8 x 10 ⁻⁶ (10.4)	—	6.1 x 10 ⁻⁶ (11.0)
70/200 F (21/93 C)	6.0 x 10 ⁻⁶ (10.8)	6.0 x 10 ⁻⁶ (10.8)	6.3 x 10 ⁻⁶ (11.3)	6.6 x 10 ⁻⁶ (11.9)
70/400 F (21/204 C)	6.0 x 10 ⁻⁶ (10.8)	6.0 x 10 ⁻⁶ (10.8)	6.5 x 10 ⁻⁶ (11.7)	6.9 x 10 ⁻⁶ (12.4)
70/600 F (21/315 C)	6.2 x 10 ⁻⁶ (11.2)	6.3 x 10 ⁻⁶ (11.3)	6.6 x 10 ⁻⁶ (11.9)	7.1 x 10 ⁻⁶ (12.8)
70/800 F (21/426 C)	6.3 x 10 ⁻⁶ (11.3)	6.5 x 10 ⁻⁶ (11.7)	6.8 x 10 ⁻⁶ (12.2)	7.2 x 10 ⁻⁶ (13.0)
70/900 F (21/482 C)	—	—	—	7.3 x 10 ⁻⁶ (13.1)
Thermal Conductivity BTU/hr/ft ² /in/°F (W/m°C)				
300 F (149 C)	—	124 (17.9)	—	—
500 F (260 C)	—	135 (19.5)	—	—
860 F (460 C)	—	156 (22.5)	—	—
900 F (482 C)	—	157 (22.6)	—	—
Specific Heat BTU/lb/°F (J/kg°C)				
32/212 F (0/100 C)	0.11 (460)	0.10 (418)	—	—

* Data represent one test from one heat.

Magnetic Properties

Normal induction and hysteresis curves are shown in Figures 6 and 7. There is little difference in the magnetic properties of material heat treated to Conditions H 900 and H 1075. However, magnetic properties of material heated to Condition H 1150 are significantly lower.

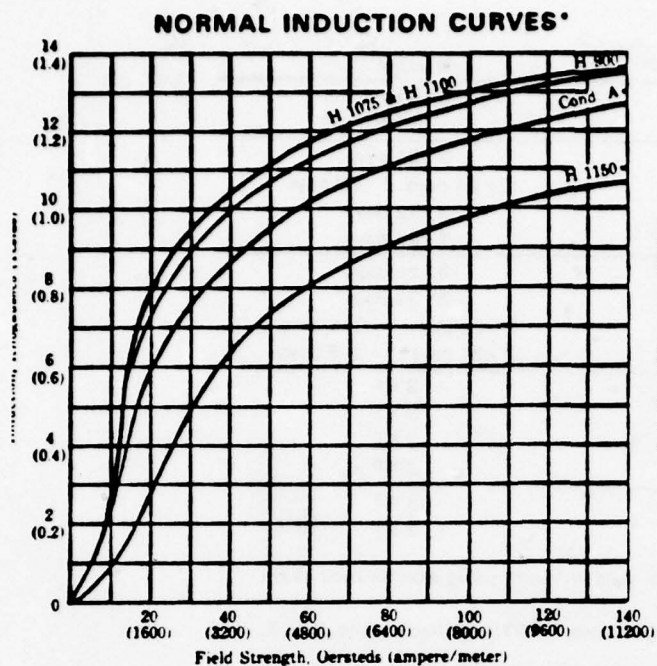

Figure 6 *Data represent single tests from three heats

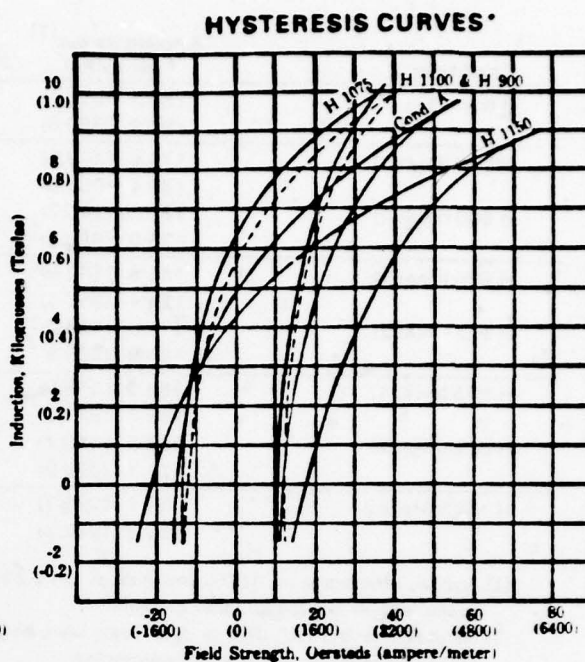

Figure 7

CORROSION RESISTANCE

The general level of corrosion resistance of Armco 15-5 PH VAC CE stainless steel exceeds that of Types 410 and 431, and is approximately equal to that of Armco 17-4 PH stainless steel. This is indicated by laboratory tests in both strongly oxidizing and reducing media, as well as by atmospheric exposures. In all heat-treated conditions, Armco 15-5 PH VAC CE stainless exhibits very little rusting after 500 hours' exposure to 5% salt fog at 95 F (35 C). When exposed to seacoast atmosphere for long periods of time, Armco 15-5 PH VAC CE stainless gradually develops a superficial overall layer of rust like other precipitation-hardening stainless steels. The general level of corrosion resistance of Armco 15-5 PH VAC CE stainless is best in the fully hardened condition, and decreases slightly as the aging temperature is increased.

Stress Corrosion Resistance

The following data were obtained on .052" (1.3 mm) strip samples of Armco 15-5 PH VAC CE stainless steel from two heats exposed in triplicate on a location 80 feet (24 m) from the ocean at Kure Beach, North Carolina.

Condition	Applied Stress ⁽¹⁾ ksi (MPa)	Results ⁽²⁾
A (Heat 1)	133.2 (918.1) 99.9 (688.6)	3 NF 3 NF
H 900 (Heat 1)	172.5 (1189.0) 129.4 (892.0)	3 - 21 days 2 - 21 days; 1 - 28 days
H 900 (Heat 2)	180.0 (1240.7) 135.0 (930.6)	3 - 22 days 3 - 22 days
H 925 (Heat 1)	165.8 (1142.9) 124.4 (857.5)	3 - 23 days 3 - 23 days
H 925 (Heat 2)	171.8 (1184.2) 128.9 (888.5)	2 - 22 days; 1 - 266 days 2 - 22 days; 1 - 109 days
H 975 (Heat 1)	159.0 (1096.0) 119.3 (822.3)	3 NF 3 NF
H 975 (Heat 2)	162.3 (1118.7) 121.7 (838.9)	3 NF 3 NF
H 1025 (Heat 2)	159.1 (1096.7) 119.3 (822.3)	3 NF 3 NF

(1) Applied stresses were 100% and 75% of the 0.2% yield strength, using smooth bent beam specimens in the longitudinal direction.

(2) NF indicates NO FAILURE to date. Tests were begun June 5, 1973, for Heat 1 and June 3, 1971, for Heat 2, and are still continuing.

These data indicate Armco 15-5 PH VAC CE stainless steel is highly resistant to stress corrosion cracking in marine atmosphere when aged at temperatures of 975 F (523 C) and higher. For maximum resistance to chloride stress cracking, Armco 15-5 PH VAC CE stainless should be aged at the maximum temperature that will yield the required properties, but not less than 975 F (523 C).

FABRICATION

Heat Treatment

For maximum hardness and strength, material in the solution-treated condition is heated for one hour at 900 ± 15 F (482 ± 8 C) and air cooled to room temperature. If material purchased in the solution-treated condition (Condition A) is hot worked, it must be solution-treated after such working and before hardening.

All surfaces should be free of cutting lubricants and other foreign matter before any heat-treating operation is performed.

Where ductility in the hardened condition is especially important, better toughness can be obtained by raising the temperature of the hardening heat treatment. Unlike regular hardenable materials which require a hardening plus a tempering or stress-relieving treatment, Armco 15-5 PH VAC CE stainless steel can be hardened to the final desired properties in one operation. By heat treating at temperatures from 900 to 1150 F (482 to 621 C), a wide range of properties can be attained. A heat treatment of 4 hours is generally used for all hardening heat treatments except 900 F (482 C), for which a one-hour treatment is used.

If Armco 15-5 PH VAC CE stainless is not ductile enough in any given hardened condition, it can be reheat-treated at a higher temperature to increase impact strength and elongation. This retreatment can be made without a solution treatment prior to the final heat treatment. However, if the material is not hard enough or strong enough it must be resolution treated, and then hardened at a lower temperature.

For material hot worked or forged, or castings, a solution treatment at 1875 to 1925 F (1022 to 1050 C) for 1/2 hour, followed by cooling to at least 90 F (32 C) must be done prior to hardening. Oil quenching rather than air cooling may be used on small, simple sections. This treatment will refine the grain size and make hardened material more uniform.

On hardening Armco 15-5 PH VAC CE stainless steel, a dimensional change will take place. Typical dimensional changes are shown below. They can vary from heat to heat.

Table XVII
Contraction From Heat Treatment*

H 900		.00045 in/in
H 925		.00051 in/in
H 1025		.00053 in/in
H 1100		.0009 in/in
H 1150		.0022 in/in
H 1150-M	1400→	.00037 in/in
	1150→	.00206 in/in
	∴ 1400 + 1150→	.00243 in/in

* Data represent single tests from one heat.

Importance of Cooling to 90 F (32 C) in Fabricating and Heat Treating Armco 15-5 PH VAC CE Stainless Steel

In fabricating Armco 15-5 PH VAC CE stainless, it is important to keep in mind the low temperatures at which the start of transformation to martensite (M_s) and the finish of the martensite transformation (M_f) occur. These temperatures are approximately 270 F (132 C) and 90 F (32 C), respectively.

Because of this characteristic, it is necessary to cool parts in process at least to 90 F (32 C) prior to applying subsequent heat treatments if normal final properties are to be obtained. This practice is essential to assure grain refinement, and to assure the product will have the good ductility of which this alloy is capable. Examples of situations where cooling to 90 F (32 C) is an important step follow:

- 1) Cool a forged part to 90 F (32 C) after final forging before solution treating.
- 2) Cool to 90 F (32 C) after heat treating at 1400 F (760 C) prior to aging at 1150 F (621 C) in the H 1150-M treatment.
- 3) Cool to 90 F (32 C) after solution treating prior to applying any of the precipitation-hardening treatments.

Surface Hardening

Armco 15-5 PH VAC CE stainless steel can be nitrided when increased resistance to galling and wear is required. An advantage obtained in using Armco 15-5 PH VAC CE stainless rather than a standard chromium or chromium-nickel stainless steel is that the core is simultaneously strengthened and toughened during the nitriding treatment.

Using the gas-phase method, case hardnesses of approximately Rockwell C67 have been obtained to a depth of 0.004" to 0.006" (0.1 mm to 0.15 mm). This method of nitriding utilizes a

temperature of about 1050 F (565 C) and results in a tough core with a hardness of about Rockwell C36. However, nitriding considerably decreases the corrosion resistance of Armco 15-5 PH VAC CE stainless (as it does with any stainless steel). Nitrided Armco 15-5 PH VAC CE stainless should be used only in mildly corrosive applications.

Forging

Forging is an excellent method of forming intricate shapes of Armco 15-5 PH VAC CE stainless steel. Forging blanks should be heated uniformly to 2150 to 2200 F (1176 to 1204 C) and held at temperature at least 15 minutes before forging. On large sections over 3/4" (19 mm) diameter or thickness, it is recommended the material be heated for 1/2 hour per inch (25.4 mm) of thickness at 2150 to 2200 F (1176 to 1204 C) and held for one-half to one hour at temperature prior to forging. Heating above 2200 F (1204 C) may cause undesirable grain coarsening. The temperature during the forging operation should not be permitted to drop below 1850 F (1008 C). The material should be reheated in the furnace when this temperature is reached. After forging, the material should be cooled below 90 F (32 C) to assure complete transformation. To secure optimum toughness in the final hardened condition, forged parts must first be put into Condition A by reheating to 1875 to 1925 F (1022 to 1050 C) and air cooling (or oil quenching small simple parts).

Complete forging practices for Armco 15-5 PH VAC CE stainless steel are similar to those found in the Fabricating Data Bulletin covering the forging and heat treating of Armco 17-4 PH and 17-7 PH billets, bars and forgings.

In critical types of upset forgings and hot flattening operations, Armco 17-4 PH stainless steel may split and rupture. Armco 15-5 PH VAC CE stainless will perform better because it has no delta ferrite, and minimal directionality.

Welding

Sound joints can easily be produced in Armco 15-5 PH VAC CE stainless with proper welding practice. Properties comparable to those of the parent metal can be secured in the weld by postweld heat treatment. Procedures employed for welding are similar to those ordinarily used for the austenitic types, even though the composition of Armco 15-5 PH VAC CE stainless and its structure more closely resemble that of a martensitic stainless steel. Any of the arc and resistance welding processes used on the regular grades of stainless steel are suitable for Armco 15-5 PH VAC CE stainless steel. The most outstanding welding property of this steel is its ability to withstand welding operations without requiring preheating.

Favorable composition accounts for the good performance of Armco 15-5 PH VAC CE stainless in welding. The very low carbon content is an important feature because it restricts the hardness of rapidly cooled material and avoids the formation of cracks in the weld metal and the heat-affected zone of the base metal. This eliminates the need for pre-heating. While the Armco 15-5 PH VAC CE stainless base metal shows no susceptibility to spontaneous underbead cracking from weld hardening, it does not possess the high ductility and toughness of austenitic Cr-Ni steels. Therefore, it should not be subjected to high levels of biaxial or triaxial stress from severely restrained weldments or exposed to notched conditions. Weldment design should be given the same attention required for any high-strength alloy steel to avoid the concentration of residual welding stress or reaction stress at square corners, unfused notches and sharp threads.

In fusion welding, it is important that consideration be given to proper control of the weld deposit composition. Fillerless welds such as are possible with the Gas Tungsten-Arc and Electron Beam processes should be avoided. A filler should always be added. The addition or use of W 17-4 PH electrodes and filler material are suggested for weld deposits where mechanical properties equivalent to those of the parent metal are needed. Where the weld deposit is not required to have a strength level equivalent to that of the parent metal, a Type 308 stainless steel electrode may be used. The information found in the Fabricating Data Bulletin on Welding Armco 17-4 PH stainless steel will be helpful in welding Armco 15-5 PH VAC CE stainless steel.

Machining

Armco 15-5 PH VAC CE stainless steel can be machined in either the solution-treated or any of the heat-treated conditions. One of the important advantages of the alloy is it can be finish machined in Condition A, then heat treated. Because the final hardening temperatures are low, there is no harmful scaling or distortion. Design allowance can be made for the predictable contraction on hardening.

Machining rates for Armco 15-5 PH VAC CE stainless steel in Condition A are similar to those for Types 302 and 304 stainless steels. In the hardened condition (H 900) this material should be machined at 60% of the rate used for Condition A. Surface finishes in either condition are excellent. Best tool life is achieved from Condition H 1150-M; however, higher cutting forces may be encountered.

Cutting

In general, the cutting procedures commonly used for the standard chromium-nickel types also apply to Armco 15-5 PH VAC CE stainless steel.

Cold sawing is recommended for cutting bars and forging billets. Hot cutting or abrasive wheel cutting with a large volume of coolant has been used successfully. However, it should be noted that abrasive wheel cutting can cause small surface cracks on the cut face.

Torch cutting Armco 15-5 PH VAC CE stainless steel requires a process suited for cutting stainless steel, such as flux-injection, powder cutting, oxy-arc or arc-air methods. Since the heat-affected zones of Armco 15-5 PH VAC CE stainless are not significantly hardened or embrittled by the localized heat of welding or torch cutting, this alloy offers good possibilities for oxygen or air torch cutting. Armco 15-5 PH VAC CE stainless bars can be torch cut by flux-injection or iron powder processes.

Descaling

Hardening treatments produce only a light heat tint on surfaces. This heat tint can easily be removed with a few-minute pickle in 10% nitric-2% hydrofluoric acid (by volume) at 110 to 140 F (43 to 60 C). This treatment also passivates or cleans the surfaces for maximum corrosion resistance. Where pickling is undesirable, heat tint may be removed by electropolishing.

Where forging or solution treating is performed, the following pickling method satisfactorily removes surface scale. The use of sodium hydride or Virgo process to descale is limited since these methods harden solution-treated material.

Table XVIII
Descaling Procedures

Procedure	Acid Bath	Temp. F (C)	Time Temp. Minutes	Rinse
Step 1	Caustic Permanganate	160-180 (71-83)	60	Water rinse
Step 2	10% Nitric Acid + 2% Hydrofluoric Acid	110-140 (43-60)	2-3	Hot water, high pressure water or brush scrub

In pickling operations, close control of time and temperature is necessary to obtain uniform scale removal without over-etching.

The most satisfactory method of removing scale resulting from the solution treatment or from forging is grit blasting. Scale softening methods may be used on material that has been solution treated (not pickled) and precipitation hardened.

APPENDIX G

STRESS IN THE TRANSDUCER DIAPHRAGM
DUE TO THERMAL SHOCK DURING HEAT TREATMENT

by David S. Wood

When the transducer body is removed from the furnace and air cooled, the temperature may differ from point to point within the transducer body due to the relatively rapid cooling and the finite thermal conductivity of the material. Such temperature differences may induce significant stresses due to differential thermal contraction. If these stresses exceed the yield stress of the material, at the temperature involved, plastic deformation will occur in the transducer body which may be detrimental to its ultimate operating behavior. The thermal shock stress to be expected in the transducer body during air cooling from the solution treatment temperature of 1,900⁰F is estimated in the following analysis.

The transducer body consists of a thin flat circular diaphragm attached at its periphery to a relatively thick outer ring. The diaphragm portion tends to cool more rapidly than the outer ring because it has a higher ratio of surface area to heat capacity. Since the diaphragm is connected to the ring, heat flows radially inward from the ring into the diaphragm by conduction within the material. This tends to reduce the temperature difference between the diaphragm and the ring. At the same time, the heat transfer out from the surfaces of the diaphragm tends to increase this temperature difference. Thus the temperature distribution within the diaphragm is governed by the balance between heat conduction within the material and heat transfer from its surface. In order to estimate this temperature distribution quantitatively, we make the following simplifying approximations:

1. The heat transfer away from the surfaces of the diaphragm is by radiation. Thus the amount of heat leaving unit area of surface at any instant is eST^4 , where e is the emissivity of the surface, S is the Stephan-Boltzmann constant and T is the absolute temperature.

At and near the solution heat treatment temperature of $1,900^{\circ}\text{F} = 1,310^{\circ}\text{K}$, other mechanisms of surface heat transfer are negligible.

2. We neglect the heat capacity of the diaphragm due to its small thickness. This leads to an overestimation of the temperature gradient and the resulting stresses.

The differential equation which expresses the balance between heat flowing into and out of an infinitesimal circular ring portion of the diaphragm at radius r is then

$$\frac{1}{r} \frac{d}{dr} \left(r \frac{dT}{dr} \right) = \frac{2eS}{kh} T^4 \quad (1)$$

where k is the thermal conductivity of the material and h is the thickness of the diaphragm.

Since the heat loss by radiation is proportional to T^4 , the maximum temperature gradient and resulting stress will occur when the temperature is still near the initial heat treatment temperature, T_0 . Therefore we may linearize the differential equation in the following way:

$$\text{Let } T = T_0 (1 - \tau), \quad (2)$$

where $\tau < 1$.

$$\text{Then } T^4 = T_0^4 (1 - 4\tau), \quad (3)$$

where higher powers of τ have been neglected. When (3) is employed in (1), the result is:

$$\frac{1}{r} \frac{d}{dr} \left(r \frac{d\tau}{dr} \right) - \beta^2 \tau = -\frac{1}{4} \beta^2, \quad (4)$$

where $\beta^2 = \frac{BeST_0^3}{kh}$. (5)

The general solution of the differential equation (4) is

$$\tau = \frac{1}{4} + A J_0(i\beta r) + B N_0(i\beta r), \quad (6)$$

where J_0 and N_0 are the Bessel functions of zero order of the first and second kinds, respectively, $i = \sqrt{-1}$, and A and B are arbitrary constants.

Since τ must be finite at $r = 0$, while $N_0(i\beta r)$ is infinite at $r = 0$, we must take $B = 0$. The temperature of the diaphragm at its periphery, $r = a$, is equal to the temperature of the outer ring portion of the transducer, T_a , at any instant. Therefore we have

$$\tau = \tau_a = 1 - \frac{T_a}{T_0} \quad \text{at } r = a, \quad (7)$$

When this is employed in (6), the other integration constant is seen to be

$$A = \frac{\left(\tau_a - \frac{1}{4} \right)}{J_0(i\beta a)}. \quad (8)$$

Thus the solution, fit to the boundary conditions, is

$$\tau = \frac{1}{4} + \left(\tau_a - \frac{1}{4} \right) \frac{J_0(i\beta r)}{J_0(i\beta a)}. \quad (9)$$

Using (2) and (7) in (9), it is easy to show that the difference between the temperature of the outer ring and the temperature of the diaphragm at radius r is given by

$$T_a - T = \left(T_a - \frac{3}{4} T_0 \right) \left[1 - \frac{J_0(i\beta r)}{J_0(i\beta a)} \right] \quad (10)$$

Clearly the maximum temperature differences between the outer ring and the diaphragm occur when $T_a = T_0$ when the transducer body is first removed from furnace. Thus the maximum temperature difference is

$$T_0 - T = \frac{1}{4} T_0 \left[1 - \frac{J_0(1\beta r)}{J_0(1\beta a)} \right] \quad (11)$$

The radial and circumferential strains in the diaphragm are

$$\left. \begin{aligned} \epsilon_r &= \frac{du}{dr} = \frac{1}{E} (\sigma_r - \nu\sigma_\theta) - \alpha(T_0 - T) \\ \epsilon_\theta &= \frac{u}{r} = \frac{1}{E} (\sigma_\theta - \nu\sigma_r) - \alpha(T_0 - T) \end{aligned} \right\} \quad (12)$$

where

u = radial displacement

E = Young's modulus

ν = Poisson's ratio

α = coefficient of linear thermal expansion

σ_r = radial stress

σ_θ = circumferential stress.

The equation of equilibrium of stress in the diaphragm is

$$\frac{d\sigma_r}{dr} + \frac{1}{r} (\sigma_r - \sigma_\theta) = 0. \quad (13)$$

When equations (12) are solved for σ_r and σ_θ , and the results substituted in (13), we obtain

$$\frac{d}{dr} \left[\frac{1}{r} \frac{d}{dr} (ru) \right] = -\alpha(1 + \nu) \frac{d}{dr} (T_0 - T). \quad (14)$$

When this is integrated, using (11) for $(T_0 - T)$, the result is

$$u = -\alpha(1 + \nu) \frac{1}{4} T_0 \left[\frac{1}{2} r + \frac{iJ_1(i\beta r)}{\beta J_0(i\beta a)} \right] + \frac{1}{2} Cr + D \times \frac{1}{r} \quad (15)$$

where J_1 is the Bessel function of the first order, and C and D are integration constants.

The boundary conditions are, first, $u = 0$ at $r = 0$. Therefore, $D = 0$.

Second, $u = 0$ at $r = a$, so that

$$C = \alpha(1 + \nu) \frac{1}{4} T_0 \left[1 + 2 \frac{iJ_1(i\beta a)}{\beta a J_0(i\beta a)} \right] \quad (16)$$

Thus the displacement, fit to the boundary conditions, is

$$u = \frac{\alpha(1 + \nu)T_0}{4\beta J_0(i\beta a)} \left[iJ_1(i\beta a) \frac{r}{a} - iJ_1(i\beta r) \right] \quad (17)$$

When (17) and (11) are substituted into (12), and the results solved for the stresses, we find

$$\begin{aligned} \sigma_r &= \frac{\alpha E T_0}{4(1-\nu)} \left[1 + (1 + \nu) \frac{iJ_1(i\beta a)}{\beta a J_0(i\beta a)} + (1 - \nu) \frac{iJ_1(i\beta r)}{\beta r J_0(i\beta a)} \right] \\ \sigma_\theta &= \frac{\alpha E T_0}{4(1-\nu)} \left[1 + (1 + \nu) \frac{iJ_1(i\beta a)}{\beta a J_0(i\beta a)} - (1 - \nu) \frac{J_0(i\beta r)}{J_0(i\beta a)} - (1 - \nu) \frac{iJ_1(i\beta r)}{\beta r J_0(i\beta a)} \right] \quad (18) \end{aligned}$$

Equations (18) show that the maximum stress occurs at the center of the diaphragm, $r = 0$, where the radial and circumferential stress components are equal and given by

$$\sigma_m = \frac{\alpha E T_0}{4(1-\nu)} \left[1 + (1 + \nu) \frac{iJ_1(i\beta a)}{\beta a J_0(i\beta a)} - \frac{(1 - \nu)}{2 J_0(i\beta a)} \right] \quad (19)$$

The necessary numerical values of the material properties for 17-4PH and 15-5PH stainless steels at 1,900°F are obtained by extrapolation from data at lower temperatures, given by Republic Steel Corp., Cleveland, Ohio, in their technical bulletin, "Precipitation Hardenable Stainless Steels," 1975. These are

$$E = 20 \times 10^6 \text{ psi}$$

$$\nu = 0.272$$

$$\alpha = 16.7 \times 10^{-6}/^{\circ}\text{K}$$

$$k = 30.6 \text{ W/m}^{\circ}\text{K}.$$

The Stephan-Boltzmann constant is

$$S = 5.67 \times 10^{-8} \text{ W/m}^2(^{\circ}\text{K})^4,$$

and the solution treatment temperature is

$$T_0 = 1,310^{\circ}\text{K}.$$

The thickness and radius of the diaphragm are taken to be

$$h = 0.005 \text{ in.} = 1.27 \times 10^{-4} \text{ m}$$

$$a = 0.150 \text{ in.} = 3.81 \times 10^{-3} \text{ m}.$$

We assume that the emissivity of the diaphragm surfaces is $e = 1$. If the actual emissivity is less than one, the actual stress is somewhat less than the value obtained below.

When these values are employed in (5), it is found that

$$\beta = 512/\text{m}.$$

The difference between the temperature of the outer ring and the center of the diaphragm is given by (11) with $r = 0$, with the result

$$T_o - T_r = 0 = 180^{\circ}\text{K}$$

The corresponding value of the temperature parameter τ is

$$\tau = 0.137.$$

This shows that the linearizing approximation employed to solve the temperature distribution equation is reasonable. Finally, the stress given by (19) is

$$\sigma_m = 58,000 \text{ psi.}$$

This stress probably exceeds the yield stress of the material at the temperature involved ($1310 - 180 = 1,130^{\circ}\text{K} = 1,570^{\circ}\text{F}$), so that the diaphragm will be plastically deformed a slight amount in tension. Later, when the temperature has become uniform throughout the transducer body, this will result in a compressive stress in the diaphragm. This, in turn, will probably cause a slight buckling of the diaphragm. Such buckling may lead to nonlinear and/or unstable electrical output from the finished transducer under low applied stress.

This thermal shock and resulting plastic deformation of the diaphragm could be avoided by enclosing the transducer body in a metal container during heat treatment.

APPENDIX H

PLASTIC DEFORMATION ANALYSIS OF
DIAPHRAGM FOR OVERPRESSURE CONDITIONS

by David S. Wood

H-427

ILLUSTRATIONS

Figure		Page
H-248	Plastically Deformed Diaphragm	H-426
H-249	Plastic Strain vs Pressure Parameter	H-430

CONCLUSIONS

An analysis of the plastic deformation behavior of the transducer diaphragm was conducted under motor firing or other overpressure conditions. The conclusion is that a diaphragm 0.005 in. thick and 0.300 in. in diameter made of 15-5PH in the H900 heat treatment conditions will withstand a pressure of at least 4,650 psi before fracturing. The deflection of the center of the diaphragm under a pressure of 1,000 psi will be less than 0.0066 in.

The analysis provides formulae which may be employed to compute the corresponding results for other design parameters.

The transducer is design to operate within the range of reversible elastic stress and strain while it is employed to measure the relatively small stress in the propellant during storage. However, the much higher pressure to which it is subjected when the motor is fired will produce plastic or permanent deformation of the thin diaphragm portion of the transducer. If the diaphragm were designed to react purely elastically under firing pressure, the sensitivity and long-term stability of the transducer for measurement of prefiring propellant stresses would be seriously compromised.

The plastic deformation of the diaphragm under firing pressure should be limited so that the diaphragm does not fracture, because such a fracture might cause premature ignition of the propellant at the transducer location. The following is an analysis of the plastic behavior of the diaphragm under firing or other overpressure conditions which provides information so that the transducer can be designed to meet this requirement.

For simplification, we neglect the strengthening effect upon the diaphragm of the central support provided by the rod which connects the diaphragm to the gage beam. In other words, we neglect the force with which the gage beam tends to resist deflection of the diaphragm. Thus, we will underestimate the pressure which will cause fracture of the diaphragm and overestimate the diaphragm deflection which will be produced by a given overpressure.

The diaphragm is deformed plastically into a surface of revolution shown schematically on Figure H-248. The line AOP is the axis of symmetry and D is the diameter of the diaphragm. The line AB of length r_2 is perpendicular to

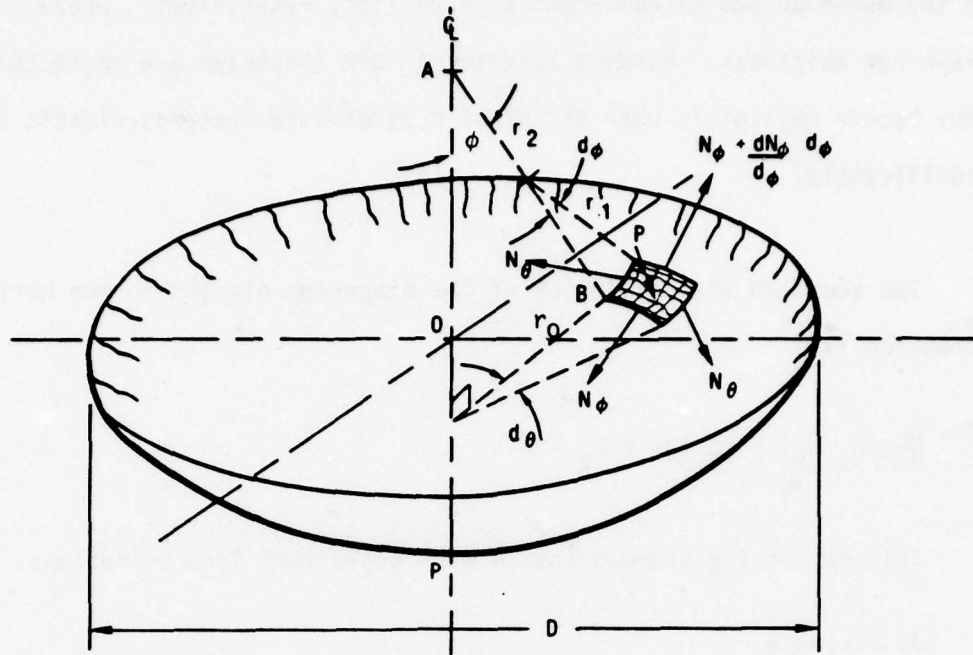

Figure H-248. Plastically Deformed Diaphragm

17710

the surface of the deformed diaphragm at an arbitrary point B, and is at an angle ϕ from the symmetry axis. The radius along a perpendicular from the symmetry axis to point B is r_0 , θ is the angular position around the symmetry axis, and r_1 is the radius of curvature of the deformed diaphragm in a meridian plane at point B. An infinitesimal element of the deformed diaphragm defined by angular increments $d\phi$ and $d\theta$ at point B is shown with the forces acting on it. The latter consist of the force per unit length in the circumferential direction, N_ϕ , the force per unit length in the meridian direction, N_θ , and the applied pressure, p .

The stresses in the diaphragm are

$$\sigma_\phi = \frac{N_\phi}{h} \quad \text{and} \quad \sigma_\theta = \frac{N_\theta}{h}, \quad (1)$$

in the meridian and circumferential directions respectively, where h is the diaphragm thickness. Bending stresses in the diaphragm are neglected because they become negligible when the plastic deformation exceeds elastic strains significantly.

The equation of equilibrium of the diaphragm element in the meridian direction is⁽¹⁾

$$\frac{d}{d\phi} (r_0 N_\phi) - r_1 \cos \phi N_\theta = 0. \quad (2)$$

This may be transformed into a more convenient form as follows:

$$ds = r_1 d\phi,$$

where ds is the dimension of the element in the meridian direction. But

$$\cos \phi ds = dr_0,$$

$$\text{so that } r_1 \cos \phi = \frac{dr_0}{d\phi}.$$

Thus, (2) may be written

$$\frac{d}{d\phi} (r_0 N_\phi) - \frac{dr_0}{d\phi} N_\theta = 0.$$

Rearranging this and using (1) gives

$$\sigma_\theta = \frac{d}{dr_0} (r_0 \sigma_\phi). \quad (3)$$

⁽¹⁾S. Timoshenko, "Theory of Plates and Shells," McGraw-Hill, 1940, p. 358.

The equation of equilibrium of that portion of the diaphragm extending from the center out to angle ϕ is⁽¹⁾

$$2\pi r_0 N_\phi \sin \phi + R = 0, \quad (4)$$

where R is the total axial load in the upward direction. In the present case,

$$R = -\pi r_0^2 p,$$

so that (4) becomes

$$N_\phi = \frac{1}{2} \frac{p r_0}{\sin \phi}.$$

Using (1) and the fact that

$$\sin \phi = \frac{r_0}{r_2},$$

this becomes

$$\sigma_\phi = \frac{1}{2} p \frac{r_2}{h}. \quad (5)$$

Now we employ the approximations that the material obeys the Tresca or maximum shear criterion of yielding, and that it does not work-harden. Both of these approximations lead to an underestimation of the pressure which will fracture the diaphragm, because they underestimate the stresses in the diaphragm slightly. According to these approximations, one or the other of the two stress components σ_ϕ and σ_θ , is a constant equal to the yield stress of the material, Y . Equation (3) shows that if one of the stress components is constant, the other is equal to the same constant. Substitution of this result in (5) then gives

$$r_2 = \frac{2Yh}{p}. \quad (6)$$

Since r_2 is independent of position, ϕ , the diaphragm is plastically deformed into a spherical cap whose radius is given by (6).

The total length along a meridian of the deformed diaphragm is

$$l = 2r_2 \phi_D, \quad (7)$$

where ϕ_D is the value of ϕ at the outer edge. Thus the plastic strain in the meridian direction is

$$E_\phi = \frac{l-D}{D} = 2 \frac{r_2}{D} \phi_D - 1. \quad (8)$$

The plastic strain in the circumferential direction must be zero at the outer diameter, and increases toward the center. At the center it must be equal to the meridional strain. Thus at the center we have an equal biaxial plastic strain given by (8). This is equivalent to a strain in simple tension of twice that value. Thus the equivalent plastic strain at the center of the diaphragm is

$$\epsilon_\rho = 4 \frac{r_2}{D} \phi_D - 2. \quad (9)$$

From the geometry of the deformed diaphragm, we have

$$\sin \phi_D = \frac{D}{2r_2}. \quad (10)$$

Solving (9) for ϕ_D , substituting the result in (10), and using (6) to replace r_2 gives

$$\sin \left[\left(1 + \frac{1}{2} \epsilon_\rho \right) \frac{pD}{4Yh} \right] = \frac{pD}{4Yh}. \quad (11)$$

Equation (11) may be solved numerically for the equivalent plastic strain, ϵ_p , as a function of the pressure parameter $\frac{1}{4} \frac{pD}{Yh}$. The result is shown graphically in Figure H-249.

The deflection at the center of the diaphragm, δ (the distance OP in Figure H-1), is given by

$$\delta = r_2 (1 - \cos \phi_D).$$

Using (6) and (10), this becomes

$$\delta = \frac{2Yh}{h} \left[1 - \sqrt{1 - \left(\frac{1}{4} \frac{pD}{Yh}\right)^2} \right]. \quad (12)$$

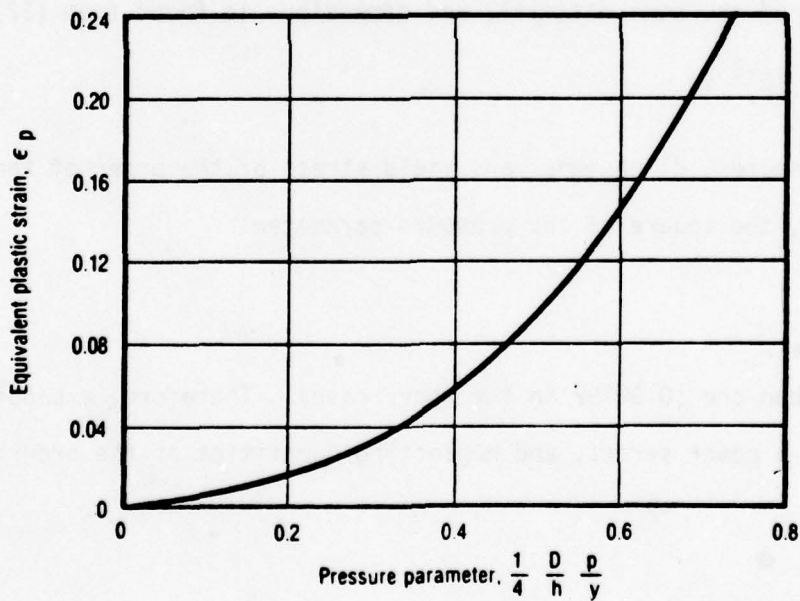

Figure H-249. Plastic Strain vs Pressure Parameter

17711

The pressure, P_f , which will fracture the diaphragm, is obtained from the graph in Figure H-261 by equating the equivalent plastic strain to the elongation in a simple tensile test. For example, if the diaphragm is made of 15-5PH stainless steel, heat treated to condition H900 so that its elongation to fracture is 0.06, the graph gives the value of the pressure parameter

$$\frac{1}{4} \frac{P_f D}{Y h} = 0.41.$$

The minimum yield stress of this material is $Y = 170,000$ psi. If we take the thickness of the diaphragm to be $h = 0.005$ in. and the diameter $D = 0.300$ in., this gives the pressure to produce fracture

$$P_f = 4,650 \text{ psi.}$$

The deflection, δ , produced by a firing pressure of $p = 1,000$ psi, acting on a diaphragm of the same material, and dimensions is found from (12)

$$\delta = 6.6 \times 10^{-3} \text{ in.}$$

Note: For pressures, dimensions, and yield stress of the order of those employed above, the square of the pressure parameter

$$\left(\frac{1}{4} \frac{pD}{Yh} \right)^2$$

is much less than one (0.00792 in the above case). Therefore, expanding the square root in a power series, and neglecting quantities of the order of

$$\left(\frac{1}{4} \frac{pD}{Yh} \right)^4$$

and higher, equation (12) becomes

$$\delta = \frac{1}{16} \frac{pD^2}{Yh} .$$

(13)

which is more convenient for calculation.

APPENDIX I
MINCO PLATINUM TEMPERATURE SENSOR
SPECIFICATION AND CALIBRATION TABLES

CONTENTS

Item	Page
Article, "Precision Miniature Platinum Resistance Thermometers	I-443
Calibration Table, Resistor S/N 229	I-451
Calibration Table, Resistor S/N 230	I-459
Calibration Table, Resistor S/N 231	I-464
Calibration Table, Resistor S.N 232	I-469
Calibration Table, Resistor S/N 233	I-474



Instrument Society of America

March 20, 1979

Ref: C139-600k-79

Re: Precision Miniature Platinum
Resistance Thermometers by
D. A. Lucas

Ref: Your letter 3/14/79

Mr. Richard E. Thompson
Research Engineer
Chemical Systems Division
P. O. Box 358
Sunnyvale, CA 94088

Dear Mr. Thompson:

This letter will constitute our permission to Chemical Systems Division of United Technologies to reproduce the above-cited materials in a technical report to the Air Force Rocket Propulsion Laboratory.

We request that the following citation be referenced at the bottom of the first page of the material:

"With permission of the copyright holder, Instrument Society of America. From 'Temperature, Its Measurement and Control in Science and Industry, Volume 4' © ISA 1972."

Yours sincerely,

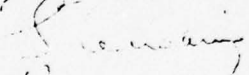
Frederic S. Cushing
Director of Publishing Services

FSC:ag

MINCO PRODUCTS, INC.

7300 Commerce Lane / Minneapolis, Minnesota 55432, U.S.A. / TWX: 910-576-2848 / Telephone : (612) 571-3121

March 20, 1979

Mr. Richard E. Thompson
Research Engineer
Chemical Systems Div.
PO Box 358
Sunnyvale, CA 94088

REFERENCE: Your March 13, 1979 letter

Permission is hereby granted for Chemical Systems Division to use Mr. D. A. Lucas' article entitled "Precision Miniature Platinum Resistance Thermometer" in your report to the U.S. Air Force.

If possible we would be interested in receiving a copy of your article as it relates to our product.

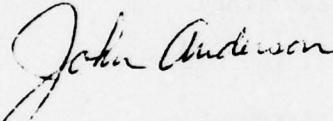

John A. Anderson
Sales Manager

JAA:ss

cc: IMA
405 Alberto Way, Suite 6
Los Gatos, CA 95030
408/358-1734

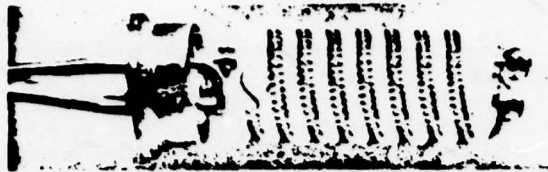

FIGURE 1. Revised design for a miniature platinum resistance thermometer improves average residual resistance ratio.

PRECISION MINIATURE PLATINUM RESISTANCE THERMOMETERS

D. A. LUCAS
Minco Products, Inc.

An improved design has removed an anomaly below 90K for the resistance temperature curve of a platinum RTD. This paper is published with the permission of the ISA, copyright reserved for the proceedings (in preparation) entitled "Temperature, Its Measure and Control in Science and Industry." Vol. 4, ISA, Pittsburgh.

ACKNOWLEDGEMENTS

The author wishes to thank B. C. Gerstein, Iowa State University, W. V. Johnston, North American Rockwell Corporation, J. L. Riddle, National Bureau of Standards, A. M. Goldman and W. V. Wehymann, University of Minnesota, L. G. Rubin, M.I.T. National Magnet Laboratory, H. G. Terbeek, N.A.S.A. Lewis Research Center and L. Van Hull, Philco-Ford, for their suggestions and comments.

The author wishes to extend a special thanks to T. H. Herder, CryoCal, Incorporated, for his technical, materials and calibration assistance.

The development of a miniature cryogenic and standard platinum resistance thermometer line was undertaken after tests of the original model¹ revealed many desirable properties for laboratory use.

Gehring and Gerstein² reported that the thermometer could be sufficiently stabilized for thermodynamic measurements by thermal shocking between liquid helium and room temperature. They found that the triple-point-of-water resistance varied by as much as 0.0043 ohm following initial thermal shockings, but remained constant to within 0.0002 ohm (0.0005K) after approximately 20 thermal shockings.

Johnston and Lindberg³ reported excellent stability and sensitivity, but detected an anomaly in the resistance-temperature curve below 90K. Their report indicated that the thermometer's ice-point resistance had remained constant within 10 parts per million over a 12-month period, had about four times the sensitivity of another commercially available platinum thermometer, and met the requirements of the International Practical Temperature Scale above 90K. However, Johnston and Lindberg also found that the resistance ratios dropped less rapidly below 90K, thus making it impossible to interpolate using the deviation plot method ordinarily used when calibrating below 90K.

Subsequent to these reports, the American Calorimetry Conference Committee on Miniature Platinum Thermometer Standardization conducted a survey in which a questionnaire was sent to those who had expressed interest in having available a miniature platinum resistance thermometer for cryogenic use.

As a result of the tests, design criteria suggested by the American Calorimetry Conference and other recommendations, the thermometer was redesigned, and several improvements were incorporated in twelve different models to meet the International Practical Temperature Scale specifications for laboratory resistance thermometers.

The following improvements were made, resulting in the revised design as shown in Fig. 1:

1. The internal and header leadwires were changed to platinum; therefore, only platinum exists in the sensing-element structure.
2. By using .051, .025 and .018mm diameter high-purity platinum wire, sensing elements of 25.5 ohms, 100 ohms and 470 ohms at 273.15K, respectively, were designed into miniature cases.
3. The solder for the case seal was changed to a gold-tin alloy, eutectic at 553K. The thermometers' upper temperature rating thus has been increased to 533K to permit calibration at the tin point.
4. Case diameter was reduced to 3.175mm for physical interchangeability with commercially available germanium thermometers.

5. The case material was changed to copper, rather than platinum, because of less cost to user and greater thermal conductivity.

6. The internal platinum leadwires exit through a glass-to-platinum hermetic header.

7. All thermometers were designed for either Teflon-insulated stranded copper lead extensions or bare platinum leadwires.

8. Magnetic materials in the case and header were replaced. All materials used are non-magnetic.

9. The .320mm diameter platinum leadwires are fully annealed for increased ductility.

10. The cases are back-filled with 98% dry helium and 2% pure oxygen.

11. All thermometers are thermally cycled from liquid helium to upper rated temperature, with repeated measurements at fixed temperature points to verify quality and stability.

The basic strain-free element configuration which had yielded such excellent results was not changed. The construction (Fig. 1) consists of a helical platinum-wire coil in a helical grooved ceramic support. This structure provides support without restricting wire expansion or contraction with temperature changes.

Several units of each resistance value were fabricated and tested to verify that design improvements were accomplished and to insure required stability and resistance properties for standard thermometers.⁴

Four 25-ohm, eight 100-ohm, and nine 470-ohm at 273.15K thermometers were fabricated. All twenty-one thermometers were tested for repeatability after helium thermal shocking. Residual resistances at the helium point were measured and resistance ratios from 373.15K to 273.15K were computed. Two thermometers of the original design were brought through the same test program to compare residual resistance at the helium point. A 100-ohm thermometer was calibrated from 4.2K to 100K. The calibration results were used to determine if resistance values could be interpolated per the I.P.T.S.-68 formulas from 13K to 273.15K.

Repeatability after helium thermal shockings was first tested to verify that the redesign had not affected resistance stability.

Seven thermometers were measured at the triple point of water and the balance at the ice point before any thermal cycling. The units then were cycled between room ambient and liquid helium, allowing sufficient time at each temperature to stabilize. Resistance measurements were repeated at the water triple-point and ice-point after 15, 20, 25 and 28 cycles.

There was no pattern of significant resistance change from 0 to 28 thermal shockings. Nineteen sensors repeated resistance within measurement equipment accuracy.

One 25-ohm thermometer changed resistance downward by .003 ohm during the first 20 shock cycles, then remained stable. One of the 100-ohm models showed an apparent shift of .03 ohm in one of five readings taken at the ice point.

The redesign evidently retained the inherent resistance stability reported by Gehring and Gerstein.

All twenty-one thermometers then were measured for resistance at the liquid helium point. The resistances obtained were divided by the final ice-point or triple-point resistances obtained after twenty-eight thermal shockings.

RESIDUAL RESISTANCE

The average residual resistance ratio for the redesigned 100-ohm thermometer was less than half that of the old design (0.00043356 vs 0.0010146). No design change had been made in the platinum element configuration, but a short section of a nickel-cobalt-iron alloy in the sensing circuit had been removed. This alloy was used for leadwires in the glass-to-metal sealed header in the original model. The thermometers' resistance values below 90K now agree with the characteristic values of platinum, indicating that the alloy removal corrected the resistance-temperature anomaly detected by Johnston and Lindberg.

There are some differences of opinion as to what the maximum and minimum residual resistances should be, but it is generally agreed that low residual resistance is an indicator of element purity, degree of anneal, and strain-free element configuration. Frank D. Werner⁵ indicates that a platinum thermometer typically would have a residual resistance ratio, $R_{273.15K} / R_{4.2K}$, of 1000/1. All twenty-one thermometers had residual resistance ratios greater than 1800/1.

ALPHA COEFFICIENT

Another measure of merit of a platinum thermometer is the *alpha coefficient*. The alpha coefficient of 21 thermometers tested was greater than the .003925 minimum required by the I.P.T.S.-68.

A 100-ohm (at 273.15K) thermometer was calibrated in small increments from 4.2K to 100K, using certified germanium thermometers as calibration standards. The residual resistance at 4.2K of the platinum thermometer exactly repeated the .045-ohm residual measured approximately one month earlier. Resistance-temperature curves for this thermometer were plotted as shown in Figs. 2 and 3 from the calibration data in Table I.

The calibration data was checked by computing the dR/dT and d^2R/dT^2 , and examining the computed values for smooth-

ness. The measured values conform closely to computed values. A dR/dT plot from 4.2K to 20K is shown in Fig. 4.

There was concern as to whether the phenomenon known as "scattering" would occur. It had been suggested that wire smaller than .076mm in diameter would have a limiting effect on the mean free path of electrons resulting in electron surface scattering. This surface scattering effect would be evidenced by a knee in the resistance-temperature curve somewhere below 20K, followed by a considerable flattening of the curve below this discontinuity point. No such discontinuity is noted in calibration data for the 100-ohm thermometer, which is plotted from 4.2K to 20K in curve form in Fig. 2. Neither do the ratios of resistance, $R_{273.15K}/R_{4.2K}$ indicate any unexpected flattening of the characteristic values. The ratios average 2200/1, 2200/1 and 1800/1 for the test thermometers having element wire diameters of .051, .025 and .018mm, respectively. These are well above the 1000/1 ratio that Werner suggests is typical of a platinum thermometer.

Resistances near the fixed points defined by the International Practical Temperature Scale of 1968⁶ were taken from the test data, and ratios at these points were computed to obtain $\Delta W(T_{68})$. A FORTRAN program was written for a computer to solve for the constants in the deviation functions as defined for the four parts of the temperature range from 13K to 273.15K by the I.P.T.S.-68.

The FORTRAN program was also written to interpolate $\Delta W(T_{68})$ at all intermediate temperatures between the fixed points selected from the test data. The ratio deviations were then algebraically added to the tabulated values $W_{CCT-68}(T_{68})$ from I.P.T.S.-68. The resulting sums were multiplied by the resistance at 273.15K for the calibrated thermometer.

The computed resistances from the Fortran program and formulas of I.P.T.S.-68 were compared with the actual measured resistance values. The deviations in the four parts are shown in Table II. Measured data of a greater degree of accuracy is needed to determine if closer correlation can be realized.

Extrapolating from 273K, the computer table value at 273.16K would have been 100.080 ohms. This was exactly the value measured at the triple point of water, 273.16K.

Several potential difficulties were noted in using the I.P.T.S.-68 interpolation formulas for calibration below 273.15K. The four polynomials and thirteen coefficients make the use of a computer imperative if derivation of a table for a particular thermometer is desired. Use of expanded ratio tables may

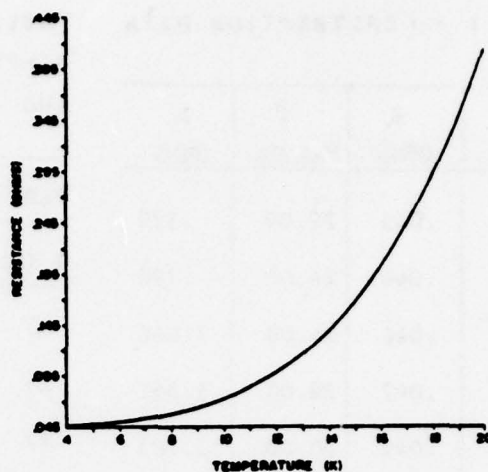

FIGURE 2. Resistance vs temperature from 4.2K to 20K for 100-ohm at 273.15K thermometer.

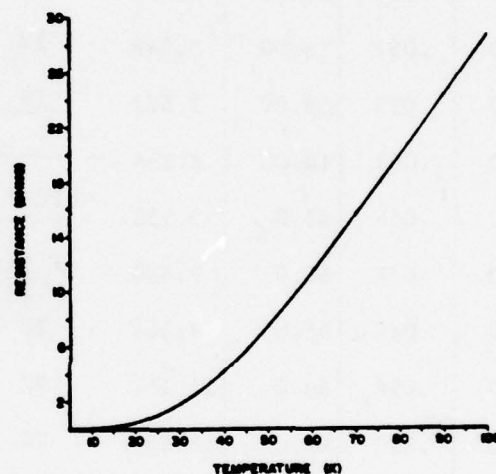

FIGURE 3. Resistance vs temperature from 5K to 100K for 100-ohm at 273.15K thermometer.

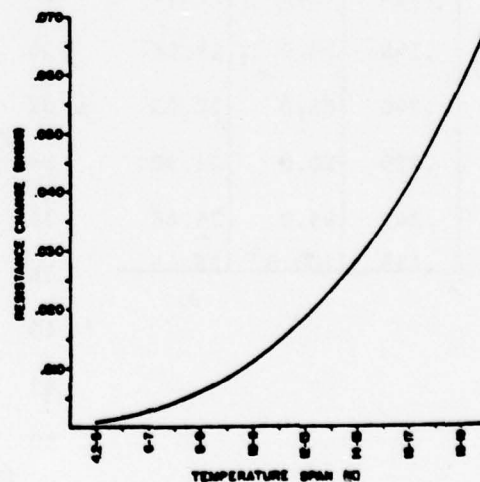

FIGURE 4. dR/dT plot (ohms per Kelvin) as a function of temperature (K); values derived from first differences of Table 1 data.

TABLE I -- CALIBRATION DATA

T KELVIN	R OHMS	T KELVIN	R OHMS
4.25	.045	22.00	.580
5.00	.046	24.00	.790
5.50	.046	26.00	1.046
6.00	.047	28.00	1.351
6.50	.049	30.00	1.703
7.00	.051	32.00	2.106
7.50	.054	34.00	2.554
8.00	.057	36.00	3.048
8.50	.059	38.00	3.583
9.00	.063	40.00	4.155
9.50	.066	45.0	5.752
10.00	.071	50.0	7.530
11.00	.082	55.0	9.444
12.00	.096	60.0	11.457
13.00	.113	65.0	13.53
14.00	.136	70.0	15.64
15.00	.164	75.0	17.79
16.00	.198	80.0	19.96
17.00	.240	85.0	22.13
18.00	.289	90.0	24.30
19.00	.347	95.0	26.48
20.00	.415	100.0	28.65

TABLE II -- RESISTANCE AND EQUIVALENT TEMPERATURE DIFFERENCES BETWEEN MEASURED AND I.P.T.S.-68 INTERPOLATED VALUES

PART 1: 13K to 20K			PART 3: 55K to 90K		
T (K)	ΔR^*	ΔK^{**}	T (K)	ΔR^*	ΔK^{**}
13	0	0	55	0	0
14	0	0	60	-.006	-.0146
15	0	0	65	0	0
16	0	0	70	+.010	+.0234
17	0	0	75	0	0
18	0	0	80	0	0
19	+.001	+.015	85	0	0
			90	0	0
PART 2: 20K to 55K			PART 4: 90K to 100K		
T (K)	ΔR^*	ΔK^{**}	T (K)	ΔR^*	ΔK^{**}
20	0	0	90	0	0
22	0	0	95	-.01	-.023
24	0	0	100	-.01	-.023
26	0	0			
28	0	0			
30	+.001	+.0051			
32	0	0			
34	+.002	+.0083			
36	+.002	+.0076			
38	+.005	+.0177			
40	+.010	+.0332			
45	+.008	+.0234			
50	+.004	+.0172			
55	0	0			

ΔR^* : Resistance difference, ohm.

ΔK^* : Equivalent temp. difference, kelvin

be used instead, but this will assume that the particular thermometer follows the table ratios exactly.

The fixed temperature points required for determination of the thirteen coefficient values are impossible to realize with most test systems. Since each of the four parts depends on the next higher part of the temperature range, it is not possible to calibrate for only part 1, for instance, without determining coefficients for parts 2, 3 and 4. It is probable that many users and manufacturers will have to find alternate means to calibrate.

Thermometer time response was measured in water flowing at 3 feet per second. The single time constants, 63.2% of the temperature change, were found to be typically 5.5 seconds, 3.5 seconds and 2.5 seconds for the 25 ohm, 100 ohm and 470 ohm thermometers, respectively. The slower time constant of the 25 ohm unit was due to an 18" stainless steel extension soldered to the thermometer case.

To determine the inductive effects when using the thermometer with an AC bridge, a 100 ohms at 273.15K thermometer was measured for inductance. The inductive reactance, $X = 2\pi fL$, was determined and used to compute the total impedance, $Z = (X^2 + R^2)^{1/2}$, at temperatures of 13K and 273.15K.

Weyhmann and Goldman, Department of Physics, University of Minnesota, measured the inductance to be in the 20 to 30 μH range at 10kHz. Using the 30 μH inductance value, the inductive reactance at 60Hz was computed to be 0.0113 ohm. Assuming that the inductive reactance is relatively independent of temperature, the total impedance was computed to be 0.113564 ohm at 13K and 100.0000006 ohms at 273.15K for a thermometer which has 0.113 ohm and 100.00 ohms of resistance at the respective temperatures.

The degree to which the inductive effects would be objectionable in using the thermometer with an AC bridge would depend on the accuracy of measurement desired, on bridge frequency, and on whether the inductive reactance can be cancelled in the bridge network.

Results of work to date that appear of most interest and significance are:

1. The redesign to all-platinum internal leads and element structure has removed the anomaly in the resistance-temperature curve below 90K.

2. The resistance-temperature characteristic of the redesigned thermometer closely follows computer-derived values, including those based on formulas of I.P.T.S.-68. Functions more practicable to use than those of I.P.T.S.-68 are needed for platinum thermometer calibration below 273.15K.

3. Thermal shockings as an integral part of the manufacturing and testing of each thermometer result in improved stability.

4. The miniaturized platinum thermometers are dimensionally interchangeable with commercially available germanium thermometers, permitting wider range of temperature measurement with essentially the same test set-up.

5. The small size of the thermometers and the relatively high thermal conductivity of the case material result in faster response to temperature changes in comparison with most larger standard thermometers.

6. Higher resistance elements in the miniature thermometers yield increased sensitivity over the conventional 25-ohm thermometers.

7. The higher resistance elements may permit use of platinum thermometers to lower temperatures than heretofore. The resistance-temperature curve of the 100-ohm thermometer is effectively flat below 6K, with the first effective resistance change of 0.004 ohm occurring between 6K and 7K. From 6K to 13K resistance increased by 0.066 ohm, or 150% over the residual resistance of 0.045 ohm at 4.2K.

8. Residual resistance as a percent of ice point resistance is somewhat lower than anticipated. Of 21 thermometers tested, all had less than 0.07% residual resistance at 4.2K, with some as low as 0.04%.

9. The phenomenon known as "scattering" does not appear to be of significance in temperature measurement with platinum wire as small as .025mm in diameter. This may extend to wire as small as .018mm in diameter, but more work is needed to verify.

Indications are that the miniature platinum thermometers described in this paper show considerable promise as precision temperature sensors for laboratory work. Their effectiveness and utility will be determined as they become more widely used and evaluated in various applications.

REFERENCES

1. Minco Model S1059.
2. F. D. Gehring and B. C. Gerstein, *Rev. Sci. Instr.* 38, 280 (1967).
3. W. V. Johnston and G. W. Lindberg, *Rev. Sci. Instr.* 39, 12 (1968).
4. D. A. Lucas and R. M. O'Brien, Minco Products, Incorporated, Minneapolis, Minnesota, Test Report 306.
5. F. D. Werner, *Temperature, Its Measurement and Control in Science and Industry* (Reinhold Publishing Corporation, New York, 1962), Vol. 3, Part 2.
6. *Metrologia*, Vol. 5, No. 2, April 1969, The International Practical Temperature Scale of 1968.

REVISIONS		
REV	DESCRIPTION	DATE
C	REVISED AND REDRAWN	2-27-70 1939
D	UPPER TEMP WAS 493°K. (220°C.)	10-7-70 1164
E	ADDED NOTE 13	6-10-72 1489

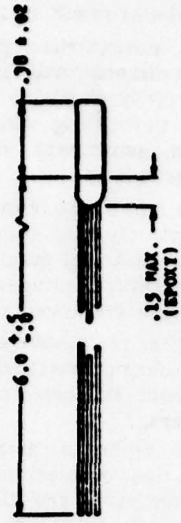

MODEL NUMBER	LEADWIRES
31059-1	AWG #20, SOLID PLATINUM, BARE
31059-2	AWG #32, STRANDED COPPER, TEPLOX INSULATED

MODEL NUMBER	TIP COLOR
31059-1	GOLD TIP
31059-2	BLUE

MINICO PRODUCTS, INC.		MINNEAPOLIS, MINN.	
RESISTANCE THERMOMETER		SCALE	2K
MINIATURE PRECISION		SHEET	9
MODEL 31059		SHEET	1 OF 1

13. TIME CONSTANT: 4 SECONDS IN WATER FLOWING AT 3 FEET PER SECOND.
12. SELF-HEAT: USE MEASURING POWER UP TO 10 MICROWATTS OR LESS TO KEEP SELF-HEAT BELOW 0.0006°K.
11. STABILITY: WITHIN 10 PARTS PER MILLION PER YEAR, MEASURED AT 0°C. (± 0.025°C).
10. REPEATABILITY: EACH THERMOMETER IS THERMALLY SHOCKED A MINIMUM OF 40 CYCLES BETWEEN 4.2°K. AND 533°K. TO INSURE REPEATABILITY AT 0°C. EQUIVALENT TO 0.001°C. ON SET-UP.
9. WEIGHT: THERMOMETER APPROXIMATELY 0.5 GRAM; LEADS APPROXIMATELY 0.9 GRAM.
8. THERMOMETER MATERIALS ARE NON-MAGNETIC.
7. CASE: COPPER, GOLD PLATED.
6. LEADS: SEE TOLERANCE BLOCK.
5. INSULATION RESISTANCE: 1,000 MEGOHMS MINIMUM AT 100 VOLTS D.C.; LEADS TO CASE.
4. TEMPERATURE RANGE: WILL WITHSTAND 4.2°K. TO 533°K. (-269°C. TO 260°C.).
3. R100°C./100°C.: GREATER THAN 1.3925.
2. RESISTANCE: 100 OHMS ± .5% (100.5/99.5) AT 273.15°K. (0°C.), NOT INCLUDING LEADWIRE RESISTANCE. RESISTANCE CHANGE APPROXIMATELY 0.4 OHM/°C. AT 0°C.
1. ELEMENT: CHEMICALLY PURE PLATINUM WIRE STRAIN-FREE, IN HERMETICALLY SEALED, DRY-HELIUM-FILLED CASE.

Figure 1. Specification for Minco Platinum Temperature Sensor

NAVAL AIR REWORK FACILITY
NAVAL AIR STATION
NORTH ISLAND
SAN DIEGO CALIFORNIA

Western Standards Laboratory Type 1 Report of Calibration

FOR

TEMPERATURE MEASUREMENT SYSTEM

SUBMITTED BY:

United Technologies, Chemical Systems Division
1050 East Arques
Sunnyvale, California

Manufacturer: John Fluke Manufacturing Company
Model : 8800 A Digital Multimeter
Serial : 90986

Manufacturer: Minco Products, Incorporated
Model : S 1059-2 Platinum Resistance Thermometer
Serials : 229 through 233

This temperature measurement system consists of a digital multimeter and five platinum resistance thermometers. The system was calibrated using the 200 ohm range of the multimeter. Using this multimeter the current through the platinum resistance thermometers will vary. The 100 ohm current level is approximately 0.8 mA.

Temperature measurement accuracy is limited by the multimeter. The manufacturers ninety day accuracy is ± 0.03 ohm on the 200 ohm range. This is equivalent to 0.08°C .

Calibration constants are included with the attached tables, as are the test measurements in ohms (R1 through R4) and the test temperatures in $^{\circ}\text{C}$ (T1 through T4). The test temperatures can be correlated with the test temperatures reported for the individual platinum resistance thermometers in Report No. UT-1 through UT-5.

Platinum resistance thermometer, Serial No. 229, was subjected to three calibrations. The attached tables include all three calibrations but the first and second calibrations are for informational purposes only. The third calibration is recommended as most valid.

AMBIENT TEMP 23 $^{\circ}\text{C}$
RELATIVE HUMIDITY 43%
REPORT NO. UT-6
DATE 13 Jun 1977

PREPARED BY: J. F. Berlanga

APPROVED BY: C. G. Kullmann

RESUBMISSION DATE 13 Jun 1979

11110-NAVAIRREWORKFAC-1000G/1 (REV. 4-77)
mck

I-449

TEMPERATURE MEASUREMENT SYSTEM

FLA 8800 A Digital Multimeter, Serial 90986

MIN S 1059-2, Serials 229 through 233

REPORT NO. UT-6

This system calibration is valid only with the multimeter and thermometers as are identified above. Also, the user must take into consideration the limiting accuracy of the multimeter.

The uncertainty of the test temperatures as reported in each table is less than 0.01°C . The pertinent IPTS-68 formulas are given in the discussion on the following pages.

WESTERN STANDARDS LABORATORY
REPORT

TABLE
FOR
PLATINUM RESISTANCE THERMOMETER
CALIBRATED TO IPTS-68
SERIAL NUMBER 229
THIRD CALIBRATION
(RECOMMENDED)

NAVAL AIR REWORK FACILITY
NAVAL AIR STATION
NORTH ISLAND

NAVAL AIR REWORK FACILITY
NAVAL AIR STATION
NORTH ISLAND
SAN DIEGO, CALIFORNIA

Western Standards Laboratory Type 1 Report of Calibration

FOR

PLATINUM RESISTANCE THERMOMETER

SUBMITTED BY:

United Technologies, Chemical Systems Division
1050 East Arques
Sunnyvale, California

Manufacturer: Minco Products, Incorporated
Model : S 1059-2
Serial : 229

This thermometer was calibrated for use with continuous current of 1.0 mA through the resistance element. Three calibrations were performed and the following values were found for the constants in the International Practical Temperature Scale of 1968 (IPTS-68) formulas:

FIRST CALIBRATION

<u>CONSTANT</u>	<u>VALUE</u>
Alpha (α)	3.926262×10^{-3}
Delta (δ)	1.431287
A_4	2.947974×10^{-7}
C_4	2.000000×10^{-14} (assumed)
A	3.982458×10^{-3}
B	$- 5.619608 \times 10^{-7}$
R_0	100.3617 Ω

SECOND CALIBRATION

Alpha (α)	3.925076×10^{-3}
Delta (δ)	1.495486
A_4	$- 8.905346 \times 10^{-7}$
C_4	$- 3.298749 \times 10^{-14}$
A	3.983775×10^{-3}
B	$- 5.869896 \times 10^{-7}$
R_0	100.3629 Ω

AMBIENT TEMP 23°C

RELATIVE HUMIDITY 43%

REPORT NO. UT-1

DATE 13 Jun 1977

11ND-NAVAIREWORKFAC-10000/1 (REV. 4-77)
mck

PREPARED BY: J. F. Berlanga

APPROVED BY: C. G. Kullmann

RESUBMISSION DATE 13 Jun 1979

PLATINUM RESISTANCE THERMOMETER
MIN S 1059-2, SERIAL 229
REPORT NO. UT-1

THIRD CALIBRATION

<u>CONSTANT</u>	<u>VALUE</u>
Alpha (α)	3.924682×10^{-3}
Delta (δ)	1.513814
A ₄	$- 1.284834 \times 10^{-6}$
C ₄	2.000000×10^{-14} (assumed)
A	3.984094×10^{-3}
B	$- 5.941238 \times 10^{-7}$
R ₀	100.3649 Ω

The values given for the first and third calibration were determined from measurements near 0.01°C, 25°C, and 50°C. Values given for the second calibration were determined from measurements near 0.01°C, 100°C, 200°C, and - 195°C. The uncertainty of the measurements at the test points, expressed in temperature, is less than 0.01°C.

The first and second calibration constants and tables are included for informational purposes only. During calibration the R₀ resistance changed by the equivalent of 0.008°C. Therefore the third calibration is recommended because it reflects the most valid values at the time of the test. In addition, the R₀, as of this report, is stable, with no significant drift. The last measurement of R₀ being 100.3646 ohms.

Calibration constants are included with the attached tables, as are the test measurements in ohms (R1 through R4) and the test temperatures in °C (T1 through T4).

The pertinent IPTS-68 formulas are given in the discussion on the following pages.

PLATINUM RESISTANCE THERMOMETER
MIN S 1059-2, SERIAL 229
REPORT NO. UT-1

The actual temperature of the test points was determined by a standard platinum resistance thermometer recently calibrated by the National Bureau of Standards.

The value of R_0 is given in this Report, although precision temperature determinations with any thermometer should be based on a value of R_0 determined with a bridge that is to be used. (Reference NBS "Notes to Supplement Resistance Thermometer Reports on the IPTS-68.")

Temperatures between 0°C and 630.74°C on the new IPTS-68 are defined by the indications (resistance values) of standard platinum resistance thermometers and the following expressions:

$$t = t' + M(t') \quad (1)$$

$$t' = \frac{1}{\alpha} \left(\frac{R_t}{R_0} - 1 \right) + \delta \left(\frac{t'}{100} - 1 \right) \frac{t'}{100} \quad (2)$$

$$M(t') = .045 \left(\frac{t'}{100} \right) \left(\frac{t'}{100} - 1 \right) \left(\frac{t'}{419.58} - 1 \right) \left(\frac{t'}{630.74} - 1 \right) \quad (3)$$

where t is the temperature, at the outside of the tube protecting the platinum resistor, in $^\circ\text{C}$ on the IPTS of 1968 and R_t and R_0 are the resistances of the platinum resistor at t° and 0°C respectively, measured with a continuous current through the platinum resistor. The value of this current and the values of the constants α and δ found for this thermometer are given on the previous page. The value of $M(t')$, given by expression (3), is the same for all thermometers and is a function only of the quantity t' . The addition of the small value represented by (3) serves to make the IPTS-68 conform more closely to the thermodynamic scale than can be done with only the simple quadratic of expression (2).

An alternate form which is completely equivalent to expression (2) is

$$R_t = R_0 (1 + At' + Bt'^2) \quad (4)$$

In some instances expression (4) is less difficult to calculate than (2). The constants A and B used in (4) are related directly to α and δ .

$$A = \alpha (1 + \delta/100) \quad (5)$$

$$B = -\alpha\delta/10^4 \quad (6)$$

CAUTION: The values of A , B , and δ on the new 1968 scale are distinctly different from the corresponding values on the old 1948 or 1927 scale. The values of α and R_0 are also different but only trivially so.

Temperatures below 0°C on the new 1968 scale are calculated using a standard reference table which gives values of R_t/R_0 for a fictitious "mean" standard thermometer. This reference table and a specified deviation equation are combined to give the values for a particular thermometer. The standard reference table

PLATINUM RESISTANCE THERMOMETER
MIN S 1059-2, SERIAL 229
REPORT NO. UT-1

used for IPTS-68 is referred to as the "CCT-68" table. It is convenient to use the symbol W_t in place of R_t/R_0 . For the special reference values of R_t/R_0 tabulated in CCT-68 the special symbol W_t^* is used. The table giving values of W_t for a particular thermometer from 0°C down to -182.962°C may be calculated from the following expressions,

$$W_t = W_t^* + \Delta W_t \quad (7)$$

$$\Delta W_t = A_4 t + C_4 t^3 (t - 100) \quad (8)$$

Expression (8) is the specified deviation equation in the range 0°C to -182.962°C . The constants A_4 and C_4 to be used in expression (8) for this particular thermometer are given on the first page.

A table calculated from the constants for this thermometer is on the following pages. The first column of the table gives values of temperature. The second column gives R_t/R_0 (i.e., the ratio of the resistance at the stated temperature to the resistance at the ice point). The third column gives the inverse (reciprocal) of the difference between successive values in the second column. These reciprocal first differences are included to facilitate interpolation. The error introduced by using linear interpolation will be less than 0.0001°C .

The values stated are computed and printed by machine. Although the tables are made with care, cost and time do not permit checking every value actually printed.

The standards utilized by the Western Standards Laboratory are traceable to standards maintained by the National Bureau of Standards or by the U. S. Navy.

Attachment: Table consisting of
cover sheet and of
measurements.

PLATINUM RESISTANCE THERMOMETER SER NO. 2290000

ALPHA= 0.39246819663E-02

DELTA= 0.1513014E+01

A4=-0.1204834E-05

C4= 0.2000000E-13

A= 0.3984094E-02

B=-0.5941238E-06

R0= 0.1003649E+03

R1= 0.1003689E+03

T1= 0.0100

R2= 0.1103260E+03

T2= 25.0045

R3= 0.1202200E+03

T3= 50.0279

R4= 0.0000000E+00

T4= 0.0000

PLATINUM RESISTANCE THERMOMETER CALIBRATION TABLE SER NO. 2290000

TEMP. DEG.C	RESISTANCE RATIO	INVERSE DIFF	TEMP. DEG.C	RESISTANCE RATIO	INVERSE DIFF
-50.	0.7991774	246.93	0.	1.0000000	250.88
-49.	0.8032257	247.02	1.	1.0039853	250.92
-48.	0.8072726	247.10	2.	1.0079693	251.00
-47.	0.8113181	247.18	3.	1.0119521	251.08
-46.	0.8153623	247.27	4.	1.0159336	251.16
-45.	0.8194051	247.35	5.	1.0199140	251.24
-44.	0.8234466	247.43	6.	1.0238930	251.31
-43.	0.8274868	247.51	7.	1.0278709	251.39
-42.	0.8315256	247.60	8.	1.0318475	251.47
-41.	0.8355631	247.68	9.	1.0358229	251.55
-40.	0.8395992	247.76	10.	1.0397970	251.63
-39.	0.8436341	247.84	11.	1.0437699	251.71
-38.	0.8476676	247.92	12.	1.0477416	251.78
-37.	0.8516998	248.00	13.	1.0517120	251.86
-36.	0.8557306	248.09	14.	1.0556812	251.94
-35.	0.8597603	248.16	15.	1.0596492	252.02
-34.	0.8637885	248.24	16.	1.0636159	252.10
-33.	0.8678155	248.33	17.	1.0675814	252.17
-32.	0.8718412	248.40	18.	1.0715457	252.25
-31.	0.8758656	248.48	19.	1.0755087	252.33
-30.	0.8798887	248.56	20.	1.0794705	252.41
-29.	0.8839105	248.64	21.	1.0834311	252.49
-28.	0.8879311	248.72	22.	1.0873905	252.57
-27.	0.8919504	248.80	23.	1.0913486	252.64
-26.	0.8959684	248.88	24.	1.0953055	252.72
-25.	0.8999852	248.95	25.	1.0992612	252.80
-24.	0.9040006	249.04	26.	1.1032156	252.88
-23.	0.9080149	249.11	27.	1.1071688	252.96
-22.	0.9120279	249.19	28.	1.1111208	253.04
-21.	0.9160396	249.27	29.	1.1150716	253.12
-20.	0.9200500	249.35	30.	1.1190211	253.19
-19.	0.9240592	249.43	31.	1.1229694	253.27
-18.	0.9280672	249.51	32.	1.1269165	253.35
-17.	0.9320739	249.58	33.	1.1308624	253.43
-16.	0.9360794	249.66	34.	1.1348070	253.51
-15.	0.9400837	249.74	35.	1.1387504	253.59
-14.	0.9440867	249.81	36.	1.1426926	253.67
-13.	0.9480885	249.89	37.	1.1466336	253.74
-12.	0.9520890	249.97	38.	1.1505734	253.82
-11.	0.9560884	250.04	39.	1.1545119	253.90
-10.	0.9600865	250.12	40.	1.1584492	253.98
-9.	0.9640833	250.20	41.	1.1623853	254.06
-8.	0.9680790	250.27	42.	1.1663202	254.14
-7.	0.9720734	250.35	43.	1.1702538	254.22
-6.	0.9760665	250.43	44.	1.1741862	254.30
-5.	0.9800585	250.50	45.	1.1781174	254.37
-4.	0.9840492	250.59	46.	1.1820474	254.45
-3.	0.9880387	250.66	47.	1.1859762	254.53
-2.	0.9920270	250.73	48.	1.1899038	254.61
-1.	0.9960141	250.81	49.	1.1938301	254.69
0.	1.0000000	250.88	50.	1.1977552	254.77

PLATINUM RESISTANCE THERMOMETER CALIBRATION TABLE SER NO. 2290000

TEMP. DEG.C	RESISTANCE RATIO	INVERSE DIFF	TEMP. DEG.C	RESISTANCE RATIO	INVERSE DIFF
50.	1.1977552	254.77	100.	1.3924682	258.75
51.	1.2016791	254.85	101.	1.3963318	258.83
52.	1.2056018	254.93	102.	1.4001941	258.91
53.	1.2095233	255.01	103.	1.4040553	258.99
54.	1.2134435	255.09	104.	1.4079152	259.07
55.	1.2173626	255.16	105.	1.4117740	259.15
56.	1.2212804	255.24	106.	1.4156316	259.23
57.	1.2251970	255.32	107.	1.4194879	259.31
58.	1.2291124	255.40	108.	1.4233431	259.39
59.	1.2330266	255.48	109.	1.4271971	259.47
60.	1.2369396	255.56	110.	1.4310499	259.55
61.	1.2408513	255.64	111.	1.4349014	259.63
62.	1.2447619	255.72	112.	1.4387518	259.71
63.	1.2486712	255.80	113.	1.4426010	259.79
64.	1.2525794	255.88	114.	1.4464490	259.88
65.	1.2564863	255.96	115.	1.4502958	259.96
66.	1.2603920	256.04	116.	1.4541415	260.04
67.	1.2642965	256.12	117.	1.4579859	260.12
68.	1.2681998	256.19	118.	1.4618291	260.20
69.	1.2721018	256.27	119.	1.4656711	260.28
70.	1.2760027	256.35	120.	1.4695120	260.36
71.	1.2799024	256.43	121.	1.4733516	260.44
72.	1.2838008	256.51	122.	1.4771901	260.52
73.	1.2876980	256.59	123.	1.4810273	260.60
74.	1.2915941	256.67	124.	1.4848634	260.68
75.	1.2954889	256.75	125.	1.4886983	260.76
76.	1.2993825	256.83	126.	1.4925319	260.85
77.	1.3032749	256.91	127.	1.4963644	260.93
78.	1.3071661	256.99	128.	1.5001957	261.01
79.	1.3110561	257.07	129.	1.5040258	261.09
80.	1.3149449	257.15	130.	1.5078548	261.17
81.	1.3188325	257.23	131.	1.5116825	261.25
82.	1.3227189	257.31	132.	1.5155090	261.33
83.	1.3266041	257.39	133.	1.5193344	261.41
84.	1.3304881	257.47	134.	1.5231585	261.50
85.	1.3343708	257.55	135.	1.5269815	261.58
86.	1.3382524	257.63	136.	1.5308033	261.66
87.	1.3421328	257.71	137.	1.5346239	261.74
88.	1.3460119	257.79	138.	1.5384433	261.82
89.	1.3498899	257.87	139.	1.5422615	261.90
90.	1.3537667	257.95	140.	1.5460785	261.98
91.	1.3576422	258.03	141.	1.5498944	262.07
92.	1.3615166	258.11	142.	1.5537090	262.15
93.	1.3653897	258.19	143.	1.5575225	262.23
94.	1.3692617	258.27	144.	1.5613347	262.31
95.	1.3731324	258.35	145.	1.5651458	262.39
96.	1.3770020	258.43	146.	1.5689557	262.47
97.	1.3808703	258.51	147.	1.5727645	262.56
98.	1.3847375	258.59	148.	1.5765720	262.64
99.	1.3886034	258.67	149.	1.5803783	262.72
100.	1.3924682	258.75	150.	1.5841835	262.80

WESTERN STANDARDS LABORATORY
REPORT

TABLE
FOR
PLATINUM RESISTANCE THERMOMETER

CALIBRATED TO IPTS-68

SERIAL NUMBER 230

NAVAL AIR REWORK FACILITY
NAVAL AIR STATION
NORTH ISLAND

I-459

NAVAL AIR REWORK FACILITY
NAVAL AIR STATION
NORTH ISLAND
SAN DIEGO, CALIFORNIA

Western Standards Laboratory Type 1 Report of Calibration

FOR

PLATINUM RESISTANCE THERMOMETER

SUBMITTED BY:

United Technologies, Chemical Systems Division
1050 East Arques
Sunnyvale, California

Manufacturer: Minco Products, Incorporated
Model : S 1059-2
Serial : 230

This thermometer was calibrated for use with continuous current of 1.0 mA through the thermometer. The following values were found for the constants in the International Practical Temperature Scale of 1968 (IPTS-68) formulas:

<u>CONSTANT</u>	<u>VALUE</u>
Alpha (α)	3.925688×10^{-3}
Delta (δ)	1.480910
A ₄	$- 2.790979 \times 10^{-7}$
C ₄	2.000000×10^{-14} (assumed)
A	3.983824×10^{-3}
B	$- 5.813589 \times 10^{-7}$
R ₀	100.3399 Ω

The pertinent IPTS-68 formulas are given in the discussion on pages I-454 and I-455.

The values given were determined from measurements near 0.01°C, 25°C, and 50°C. The uncertainty of the measurements at the test points, expressed in temperature, is less than 0.01°C.

AMBIENT TEMP 23°C
RELATIVE HUMIDITY 43%
REPORT NO. UI-2
DATE 9 Jun 1977

PREPARED BY J. F. Berlanga
APPROVED BY: C. G. Kullmann
RESUBMISSION DATE 9 Jun 1979

11ND-NAVAIREWORKFAC-10000/1 (REV. 4-77)

mck

I-460

PLATINUM RESISTANCE THERMOMETER SER NO. 2300000

ALPHA= 0.39256877021E-02

DELTA= 0.1480910E+01

A4= -0.2790979E-06

C4= 0.2000000E-13

A= 0.3983824E-02

B= -0.5813589E-06

R0= 0.1003399E+03

R1= 0.1003439E+03

T1= 0.0100

R2= 0.1103019E+03

T2= 25.0129

R3= 0.1201920E+03

T3= 50.0283

R4= 0.0000000E+00

T4= 0.0000

PLATINUM RESISTANCE THERMOMETER CALIBRATION TABLE SER NO. 2300000

TEMP. DEG.C	RESISTANCE RATIO	INVERSE DIFF	TEMP. DEG.C	RESISTANCE RATIO	INVERSE DIFF
-50.	0.7291271	246.87	0.	1.0000000	250.82
-49.	0.8031764	246.96	1.	1.0039850	250.94
-48.	0.8072243	247.04	2.	1.0079688	251.02
-47.	0.8112709	247.12	3.	1.0119514	251.09
-46.	0.8153161	247.21	4.	1.0159328	251.17
-45.	0.8193599	247.29	5.	1.0199129	251.25
-44.	0.8234024	247.37	6.	1.0238919	251.32
-43.	0.8274436	247.45	7.	1.0278696	251.40
-42.	0.8314834	247.54	8.	1.0318461	251.48
-41.	0.8355219	247.62	9.	1.0358215	251.55
-40.	0.8395590	247.70	10.	1.0397956	251.63
-39.	0.8435949	247.78	11.	1.0437685	251.71
-38.	0.8476294	247.86	12.	1.0477401	251.78
-37.	0.8516626	247.94	13.	1.0517106	251.86
-36.	0.8556944	248.03	14.	1.0556799	251.94
-35.	0.8597251	248.10	15.	1.0596480	252.01
-34.	0.8637544	248.18	16.	1.0636148	252.09
-33.	0.8677823	248.27	17.	1.0675805	252.17
-32.	0.8718090	248.34	18.	1.0715449	252.24
-31.	0.8758344	248.42	19.	1.0755082	252.32
-30.	0.8798585	248.50	20.	1.0794702	252.40
-29.	0.8838814	248.58	21.	1.0834311	252.47
-28.	0.8879030	248.66	22.	1.0873907	252.55
-27.	0.8919232	248.74	23.	1.0913491	252.63
-26.	0.8959422	248.82	24.	1.0953064	252.70
-25.	0.8999601	248.89	25.	1.0992624	252.78
-24.	0.9039765	248.98	26.	1.1032172	252.86
-23.	0.9079917	249.05	27.	1.1071708	252.93
-22.	0.9120057	249.13	28.	1.1111232	253.01
-21.	0.9160185	249.21	29.	1.1150745	253.09
-20.	0.9200299	249.29	30.	1.1190245	253.16
-19.	0.9240401	249.36	31.	1.1229733	253.24
-18.	0.9280491	249.44	32.	1.1269209	253.32
-17.	0.9320568	249.52	33.	1.1308674	253.39
-16.	0.9360633	249.59	34.	1.1348126	253.47
-15.	0.9400686	249.67	35.	1.1387566	253.55
-14.	0.9440726	249.75	36.	1.1426994	253.62
-13.	0.9480754	249.82	37.	1.1466411	253.70
-12.	0.9520770	249.90	38.	1.1505815	253.78
-11.	0.9560773	249.98	39.	1.1545208	253.86
-10.	0.9600764	250.05	40.	1.1584588	253.93
-9.	0.9640743	250.14	41.	1.1623957	254.01
-8.	0.9680709	250.21	42.	1.1663313	254.09
-7.	0.9720663	250.29	43.	1.1702658	254.16
-6.	0.9760605	250.37	44.	1.1741990	254.24
-5.	0.9800535	250.44	45.	1.1781311	254.32
-4.	0.9840452	250.52	46.	1.1820620	254.40
-3.	0.9880357	250.59	47.	1.1859917	254.47
-2.	0.9920250	250.67	48.	1.1899202	254.55
-1.	0.9960131	250.75	49.	1.1938475	254.63
0.	1.0000000	250.82	50.	1.1977736	254.70

PLATINUM RESISTANCE THERMOMETER CALIBRATION TABLE SER NO. 2300000

TEMP. DEG.C	RESISTANCE RATIO	INVERSE DIFF	TEMP. DEG.C	RESISTANCE RATIO	INVERSE DIFF
50.	1.1977736	254.70	100.	1.3925688	258.60
51.	1.2016985	254.78	101.	1.3964346	258.66
52.	1.2056223	254.86	102.	1.4002993	258.75
53.	1.2095448	254.94	103.	1.4041628	258.83
54.	1.2134661	255.01	104.	1.4080251	258.91
55.	1.2173863	255.09	105.	1.4118863	258.99
56.	1.2213053	255.17	106.	1.4157463	259.07
57.	1.2252231	255.25	107.	1.4196051	259.15
58.	1.2291397	255.32	108.	1.4234627	259.23
59.	1.2330551	255.40	109.	1.4273192	259.30
60.	1.2369693	255.48	110.	1.4311745	259.38
61.	1.2408823	255.56	111.	1.4350287	259.46
62.	1.2447942	255.63	112.	1.4388816	259.54
63.	1.2487048	255.71	113.	1.4427334	259.62
64.	1.2526143	255.79	114.	1.4465841	259.70
65.	1.2565226	255.87	115.	1.4504335	259.78
66.	1.2604297	255.94	116.	1.4542818	259.86
67.	1.2643356	256.02	117.	1.4581289	259.93
68.	1.2682404	256.10	118.	1.4619749	260.01
69.	1.2721439	256.18	119.	1.4658196	260.09
70.	1.2760463	256.25	120.	1.4696633	260.17
71.	1.2799475	256.33	121.	1.4735057	260.25
72.	1.2838475	256.41	122.	1.4773470	260.33
73.	1.2877463	256.49	123.	1.4811871	260.41
74.	1.2916440	256.57	124.	1.4850261	260.49
75.	1.2955404	256.64	125.	1.4888638	260.57
76.	1.2994357	256.72	126.	1.4927005	260.65
77.	1.3033298	256.80	127.	1.4965359	260.73
78.	1.3072227	256.88	128.	1.5003702	260.80
79.	1.3111144	256.95	129.	1.5042033	260.88
80.	1.3150050	257.03	130.	1.5080353	260.96
81.	1.3188944	257.11	131.	1.5118660	261.04
82.	1.3227826	257.19	132.	1.5156957	261.12
83.	1.3266696	257.27	133.	1.5195241	261.20
84.	1.3305554	257.34	134.	1.5233514	261.28
85.	1.3344401	257.42	135.	1.5271776	261.36
86.	1.3383235	257.50	136.	1.5310025	261.44
87.	1.3422058	257.58	137.	1.5348263	261.52
88.	1.3460870	257.66	138.	1.5386490	261.60
89.	1.3499669	257.74	139.	1.5424704	261.68
90.	1.3538457	257.81	140.	1.5462908	261.76
91.	1.3577233	257.89	141.	1.5501099	261.84
92.	1.3615997	257.97	142.	1.5539279	261.92
93.	1.3654750	258.05	143.	1.5577447	262.00
94.	1.3693490	258.13	144.	1.5615604	262.08
95.	1.3732219	258.20	145.	1.5653749	262.16
96.	1.3770936	258.28	146.	1.5691883	262.24
97.	1.3809642	258.36	147.	1.5730004	262.32
98.	1.3848335	258.44	148.	1.5768115	262.40
99.	1.3887017	258.52	149.	1.5806213	262.48
100.	1.3925688	258.60	150.	1.5844300	262.56

WESTERN STANDARDS LABORATORY
REPORT

TABLE
FOR
PLATINUM RESISTANCE THERMOMETER

CALIBRATED TO IPTS-68

SERIAL NUMBER 231

NAVAL AIR REWORK FACILITY
NAVAL AIR STATION
NORTH ISLAND

I-464

NAVAL AIR REWORK FACILITY
NAVAL AIR STATION
NORTH ISLAND
SAN DIEGO, CALIFORNIA

Western Standards Laboratory Type 1 Report of Calibration

FOR

PLATINUM RESISTANCE THERMOMETER

SUBMITTED BY:

United Technologies, Chemical Systems Division
1050 East Arques
Sunnyvale, California

Manufacturer: Minco Products, Incorporated
Model : S 1059-2
Serial : 231

This thermometer was calibrated for use with continuous current of 1.0 mA through the thermometer. The following values were found for the constants in the International Practical Temperature Scale of 1968 (IPTS-68) formulas:

<u>CONSTANT</u>	<u>VALUE</u>
Alpha (α)	3.926115×10^{-3}
Delta (δ)	1.504525
A_4	1.479797×10^{-7}
C_4	2.000000×10^{-14} (assumed)
A	3.985184×10^{-3}
B	$- 5.906936 \times 10^{-7}$
R_0	100.3101 Ω

The pertinent IPTS-68 formulas are given in the discussion on pages I-454 and I-455.

The values given were determined from measurements near 0.01°C, 25°C, and 50°C. The uncertainty of the measurements at the test points, expressed in temperature, is less than 0.01°C.

AMBIENT TEMP 23°C
RELATIVE HUMIDITY 43%
REPORT NO. UT-3
DATE 9 Jun 1977

PREPARED BY: J. F. Berlanga

APPROVED BY: C. G. Kullmann

RESUBMISSION DATE 9 Jun 1979

11ND-NAVAIREWORKFAC-1000G/1 REV. 4-77
mck

I-465

PLATINUM RESISTANCE THERMOMETER SER NO. 2310000

ALPHA= 0.39261147797E-02

DELTA= 0.1504525E+01

A4= 0.1475797E-06

C4= 0.2000000E+13

A= 0.3985184E-02

B=0.5906936E-06

R0= 0.1003101E+03

R1= 0.1003141E+03

T1= 0.0100

R2= 0.1102720E+03

T2= 25.0129

R3= 0.1201608E+03

T3= 50.0283

R4= 0.0000000E+00

T4= 0.0000

PLATINUM RESISTANCE THERMOMETER CALIBRATION TABLE SER NO. 2310000

TEMP. DEG.C	RESISTANCE RATIO	INVERSE DIFF	TEMP. DEG.C	RESISTANCE RATIO	INVERSE DIFF
-50.	0.7991057	246.85	0.	1.0000000	250.79
-49.	0.8031555	246.93	1.	1.0039864	250.86
-48.	0.8072038	247.02	2.	1.0079715	250.93
-47.	0.8112508	247.10	3.	1.0119554	251.01
-46.	0.8152964	247.18	4.	1.0159381	251.09
-45.	0.8193407	247.27	5.	1.0199195	251.17
-44.	0.8233836	247.35	6.	1.0238997	251.24
-43.	0.8274252	247.43	7.	1.0278787	251.32
-42.	0.8314654	247.51	8.	1.0318564	251.40
-41.	0.8355044	247.59	9.	1.0358329	251.48
-40.	0.8395419	247.67	10.	1.0398082	251.55
-39.	0.8435782	247.75	11.	1.0437823	251.63
-38.	0.8476132	247.84	12.	1.0477551	251.71
-37.	0.8516468	247.92	13.	1.0517267	251.79
-36.	0.8556791	248.00	14.	1.0556971	251.86
-35.	0.8597101	248.07	15.	1.0596663	251.94
-34.	0.8637398	248.16	16.	1.0636342	252.02
-33.	0.8677682	248.24	17.	1.0676009	252.10
-32.	0.8717953	248.31	18.	1.0715664	252.18
-31.	0.8758212	248.40	19.	1.0755307	252.25
-30.	0.8798457	248.48	20.	1.0794937	252.33
-29.	0.8838690	248.55	21.	1.0834555	252.41
-28.	0.8878910	248.63	22.	1.0874161	252.49
-27.	0.8919117	248.72	23.	1.0913755	252.57
-26.	0.8959311	248.79	24.	1.0953336	252.64
-25.	0.8999494	248.87	25.	1.0992906	252.72
-24.	0.9039662	248.95	26.	1.1032463	252.80
-23.	0.9079819	249.02	27.	1.1072008	252.88
-22.	0.9119964	249.10	28.	1.1111540	252.96
-21.	0.9160095	249.18	29.	1.1151061	253.03
-20.	0.9200214	249.26	30.	1.1190569	253.11
-19.	0.9240320	249.34	31.	1.1230065	253.19
-18.	0.9280414	249.42	32.	1.1269549	253.27
-17.	0.9320495	249.49	33.	1.1309021	253.35
-16.	0.9360565	249.57	34.	1.1348481	253.42
-15.	0.9400622	249.65	35.	1.1387928	253.50
-14.	0.9440666	249.72	36.	1.1427363	253.58
-13.	0.9480699	249.80	37.	1.1466786	253.66
-12.	0.9520718	249.88	38.	1.1506197	253.74
-11.	0.9560726	249.95	39.	1.1545596	253.81
-10.	0.9600722	250.03	40.	1.1584983	253.89
-9.	0.9640704	250.11	41.	1.1624357	253.97
-8.	0.9680675	250.18	42.	1.1663720	254.05
-7.	0.9720634	250.26	43.	1.1703070	254.13
-6.	0.9760579	250.34	44.	1.1742408	254.21
-5.	0.9800514	250.41	45.	1.1781734	254.28
-4.	0.9840435	250.50	46.	1.1821048	254.36
-3.	0.9880344	250.57	47.	1.1860350	254.44
-2.	0.9920242	250.64	48.	1.1899640	254.52
-1.	0.9960126	250.72	49.	1.1938917	254.60
0.	1.0000000	250.79	50.	1.1978183	254.68

PLATINUM RESISTANCE THERMOMETER CALIBRATION TABLE SER NO. 2310000

TEMP. DEG.C	RESISTANCE RATIO	INVERSE DIFF	TEMP. DEG.C	RESISTANCE RATIO	INVERSE DIFF
90.	1.1978183	254.60	100.	1.3926115	258.63
91.	1.2017436	254.75	101.	1.3964768	258.71
92.	1.2056678	254.83	102.	1.4003410	258.79
93.	1.2095907	254.91	103.	1.4042039	258.87
94.	1.2135124	254.99	104.	1.4080657	258.95
95.	1.2174329	255.07	105.	1.4119262	259.03
96.	1.2213522	255.15	106.	1.4157856	259.11
97.	1.2252703	255.23	107.	1.4196438	259.19
98.	1.2291872	255.30	108.	1.4235008	259.27
99.	1.2331029	255.38	109.	1.4273566	259.35
100.	1.2370173	255.46	110.	1.4312112	259.43
101.	1.2409306	255.54	111.	1.4350647	259.51
102.	1.2448427	255.62	112.	1.4389169	259.59
103.	1.2487535	255.70	113.	1.4427680	259.67
104.	1.2526632	255.78	114.	1.4466178	259.75
105.	1.2565716	255.86	115.	1.4504665	259.83
106.	1.2604789	255.93	116.	1.4543140	259.91
107.	1.2643849	256.01	117.	1.4581603	259.99
108.	1.2682897	256.09	118.	1.4620054	260.07
109.	1.2721934	256.17	119.	1.4658494	260.15
110.	1.2760958	256.25	120.	1.4696921	260.23
111.	1.2799970	256.33	121.	1.4735337	260.31
112.	1.2838971	256.41	122.	1.4773741	260.39
113.	1.2877959	256.49	123.	1.4812132	260.47
114.	1.2916935	256.57	124.	1.4850512	260.55
115.	1.2955899	256.65	125.	1.4888881	260.63
116.	1.2994852	256.72	126.	1.4927237	260.71
117.	1.3033792	256.80	127.	1.4965581	260.79
118.	1.3072720	256.88	128.	1.5003914	260.87
119.	1.3111637	256.96	129.	1.5042235	260.95
120.	1.3150541	257.04	130.	1.5080544	261.04
121.	1.3189433	257.12	131.	1.5118841	261.12
122.	1.3228313	257.20	132.	1.5157126	261.20
123.	1.3267182	257.28	133.	1.5195400	261.28
124.	1.3306038	257.36	134.	1.5233661	261.36
125.	1.3344883	257.44	135.	1.5271911	261.44
126.	1.3383715	257.52	136.	1.5310149	261.52
127.	1.3422536	257.60	137.	1.5348375	261.60
128.	1.3461344	257.68	138.	1.5386590	261.68
129.	1.3500141	257.75	139.	1.5424792	261.76
130.	1.3538925	257.83	140.	1.5462983	261.84
131.	1.3577698	257.91	141.	1.5501162	261.92
132.	1.3616459	257.99	142.	1.5539329	262.01
133.	1.3655207	258.07	143.	1.5577484	262.09
134.	1.3693944	258.15	144.	1.5615628	262.17
135.	1.3732669	258.23	145.	1.5653759	262.25
136.	1.3771382	258.31	146.	1.5691879	262.33
137.	1.3810083	258.39	147.	1.5729987	262.41
138.	1.3848772	258.47	148.	1.5768084	262.49
139.	1.3887450	258.55	149.	1.5806168	262.57
140.	1.3926115	258.63	150.	1.5844241	262.66

WESTERN STANDARDS LABORATORY
REPORT

TABLE
FOR
PLATINUM RESISTANCE THERMOMETER

CALIBRATED TO IPTS-68

SERIAL NUMBER 232

NAVAL AIR REWORK FACILITY
NAVAL AIR STATION
NORTH ISLAND

I-469

NAVAL AIR REWORK FACILITY
NAVAL AIR STATION
NORTH ISLAND
SAN DIEGO, CALIFORNIA

Western Standards Laboratory Type 1 Report of Calibration

FOR

PLATINUM RESISTANCE THERMOMETER

SUBMITTED BY:

United Technologies, Chemical Systems Division
1050 East Arques
Sunnyvale, California

Manufacturer: Minco Products, Incorporated
Model : S 1059-2
Serial : 232

This thermometer was calibrated for use with continuous current of 1.0 mA through the thermometer. The following values were found for the constants in the International Practical Temperature Scale of 1968 (IPTS-68) formulas:

<u>CONSTANT</u>	<u>VALUE</u>
Alpha (α)	3.926852×10^{-3}
Delta (δ)	1.435639
A_4	8.855078×10^{-7}
C_4	2.000000×10^{-14} (assumed)
A	3.983228×10^{-3}
B	-5.637544×10^{-7}
R_0	100.3246 Ω

The pertinent IPTS-68 formulas are given in the discussion on pages I-454 and I-455.

The values given were determined from measurements near 0.01°C, 25°C, and 50°C. The uncertainty of the measurements at the test points, expressed in temperature, is less than 0.01°C.

AMBIENT TEMP 23°C

RELATIVE HUMIDITY 43%

REPORT NO. UT-4

DATE 9 Jun 1977

11ND-NAVAIREWORKFAC-10000 (1) REV 4-77
mck

Berlanga
PREPARED BY: J. F. Berlanga

C. G. Kullmann
APPROVED BY: C. G. Kullmann

RESUBMISSION DATE 9 Jun 1979

I-470

PLATINUM RESISTANCE THERMOMETER SER NO. 2320000

ALPHA= 0.39268523078E-02

DELTA= 0.1435639E+01

A4= 0.8855078E-06

C4= 0.2000000E-13

A= 0.3983228E-02

B=-0.5637544E-06

R0= 0.1003246E+03

R1= 0.1003286E+03

T1= 0.0100

H2= 0.1102848E+03

T2= 25.0129

H3= 0.1201752E+03

T3= 50.0283

R4= 0.0000000E+00

T4= 0.0000

AD-A073 660

UNITED TECHNOLOGIES CORP SUNNYVALE CALIF CHEMICAL SY--ETC F/G 9/1
THE DEVELOPMENT OF IMPROVED NORMAL STRESS TRANSDUCERS FOR PROPE--ETC(U)

JUN 79 E C FRANCIS, R E THOMPSON, W E BRIGGS F04611-75-C-0042

UNCLASSIFIED

CSD-2548-FR-VOL-2

AFRPL-TR-79-34-VOL-2

NL

3 of 4

AD
A073660



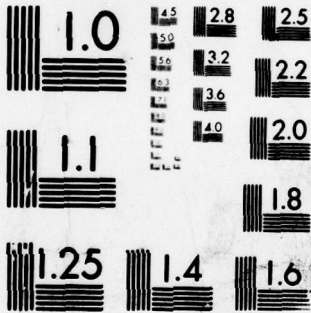

MICROCOPY RESOLUTION TEST CHART
NATIONAL BUREAU OF STANDARDS-1963-A

PLATINUM RESISTANCE THERMOMETER CALIBRATION TABLE SER NO. 2320000

TEMP. DEG.C	RESISTANCE RATIO	INVERSE DIFF	TEMP. DEG.C	RESISTANCE RATIO	INVERSE DIFF
-50.	0.7990689	246.80	0.	1.0000000	250.75
-49.	0.8031193	246.89	1.	1.0039844	250.98
-48.	0.8071684	246.97	2.	1.0079677	251.05
-47.	0.8112161	247.05	3.	1.0119498	251.13
-46.	0.8152625	247.14	4.	1.0159307	251.20
-45.	0.8193075	247.22	5.	1.0199104	251.27
-44.	0.8233511	247.30	6.	1.0238889	251.35
-43.	0.8273935	247.38	7.	1.0278663	251.42
-42.	0.8314345	247.47	8.	1.0318425	251.50
-41.	0.8354741	247.55	9.	1.0358175	251.57
-40.	0.8395124	247.63	10.	1.0397914	251.65
-39.	0.8435495	247.70	11.	1.0437640	251.72
-38.	0.8475852	247.79	12.	1.0477355	251.79
-37.	0.8516195	247.87	13.	1.0517059	251.87
-36.	0.8556525	247.95	14.	1.0556750	251.94
-35.	0.8596843	248.03	15.	1.0596430	252.02
-34.	0.8637148	248.11	16.	1.0636098	252.09
-33.	0.8677439	248.19	17.	1.0675755	252.17
-32.	0.8717717	248.27	18.	1.0715399	252.24
-31.	0.8757983	248.35	19.	1.0755032	252.31
-30.	0.8798236	248.43	20.	1.0794654	252.39
-29.	0.8838476	248.51	21.	1.0834263	252.46
-28.	0.8878704	248.59	22.	1.0873861	252.54
-27.	0.8918918	248.67	23.	1.0913447	252.61
-26.	0.8959120	248.74	24.	1.0953022	252.69
-25.	0.8999309	248.82	25.	1.0992585	252.76
-24.	0.9039485	248.90	26.	1.1032136	252.84
-23.	0.9079649	248.98	27.	1.1071676	252.91
-22.	0.9119801	249.05	28.	1.1111204	252.99
-21.	0.9159940	249.14	29.	1.1150720	253.06
-20.	0.9200066	249.21	30.	1.1190225	253.13
-19.	0.9240180	249.29	31.	1.1229718	253.21
-18.	0.9280281	249.37	32.	1.1269199	253.28
-17.	0.9320370	249.44	33.	1.1308669	253.36
-16.	0.9360447	249.52	34.	1.1348127	253.43
-15.	0.9400511	249.60	35.	1.1387573	253.51
-14.	0.9440563	249.68	36.	1.1427008	253.58
-13.	0.9480603	249.75	37.	1.1466431	253.66
-12.	0.9520630	249.83	38.	1.1505843	253.73
-11.	0.9560645	249.91	39.	1.1545243	253.81
-10.	0.9600648	249.98	40.	1.1584631	253.88
-9.	0.9640638	250.06	41.	1.1624008	253.96
-8.	0.9680616	250.14	42.	1.1663373	254.03
-7.	0.9720582	250.21	43.	1.1702727	254.11
-6.	0.9760535	250.29	44.	1.1742069	254.18
-5.	0.9800477	250.36	45.	1.1781400	254.26
-4.	0.9840405	250.45	46.	1.1820716	254.33
-3.	0.9880322	250.52	47.	1.1860026	254.41
-2.	0.9920227	250.60	48.	1.1899321	254.48
-1.	0.9960119	250.68	49.	1.1938606	254.56
0.	1.0000000	250.75	50.	1.1977878	254.63

PLATINUM RESISTANCE THERMOMETER CALIBRATION TABLE SER NO. 2320000

TEMP. DEG.C	RESISTANCE RATIO	INVERSE DIFF	TEMP. DEG.C	RESISTANCE RATIO	INVERSE DIFF
50.	1.1977878	254.63	100.	1.3926852	258.40
51.	1.2017139	254.71	101.	1.3965540	258.48
52.	1.2056389	254.78	102.	1.4004217	258.55
53.	1.2095627	254.86	103.	1.4042882	258.63
54.	1.2134853	254.93	104.	1.4081536	258.71
55.	1.2174068	255.01	105.	1.4120178	258.78
56.	1.2213271	255.08	106.	1.4158809	258.86
57.	1.2252463	255.16	107.	1.4197429	258.94
58.	1.2291643	255.23	108.	1.4236037	259.01
59.	1.2330812	255.31	109.	1.4274634	259.09
60.	1.2369969	255.38	110.	1.4313220	259.16
61.	1.2409115	255.46	111.	1.4351794	259.24
62.	1.2448249	255.53	112.	1.4390357	259.32
63.	1.2487372	255.61	113.	1.4428909	259.39
64.	1.2526483	255.68	114.	1.4467449	259.47
65.	1.2565583	255.76	115.	1.4505978	259.55
66.	1.2604671	255.83	116.	1.4544495	259.62
67.	1.2643748	255.91	117.	1.4583002	259.70
68.	1.2682813	255.98	118.	1.4621497	259.77
69.	1.2721866	256.06	119.	1.4659980	259.85
70.	1.2760909	256.13	120.	1.4698452	259.93
71.	1.2799939	256.21	121.	1.4736913	260.00
72.	1.2838959	256.28	122.	1.4775363	260.08
73.	1.2877966	256.36	123.	1.4813801	260.16
74.	1.2916963	256.43	124.	1.4852228	260.23
75.	1.2955948	256.51	125.	1.4890644	260.31
76.	1.2994921	256.59	126.	1.4929048	260.39
77.	1.3033883	256.66	127.	1.4967441	260.46
78.	1.3072833	256.74	128.	1.5005823	260.54
79.	1.3111772	256.81	129.	1.5044194	260.62
80.	1.3150700	256.89	130.	1.5082553	260.69
81.	1.3189616	256.96	131.	1.5120901	260.77
82.	1.3228521	257.04	132.	1.5159237	260.85
83.	1.3267414	257.11	133.	1.5197562	260.92
84.	1.3306296	257.19	134.	1.5235876	261.00
85.	1.3345166	257.27	135.	1.5274179	261.08
86.	1.3384025	257.34	136.	1.5312471	261.16
87.	1.3422873	257.42	137.	1.5350751	261.23
88.	1.3461709	257.49	138.	1.5389020	261.31
89.	1.3500533	257.57	139.	1.5427277	261.39
90.	1.3539347	257.64	140.	1.5465523	261.46
91.	1.3578149	257.72	141.	1.5503758	261.54
92.	1.3616939	257.80	142.	1.5541982	261.62
93.	1.3655718	257.87	143.	1.5580195	261.69
94.	1.3694486	257.95	144.	1.5618396	261.77
95.	1.3733242	258.02	145.	1.5656586	261.85
96.	1.3771987	258.10	146.	1.5694764	261.93
97.	1.3810720	258.17	147.	1.5732932	262.00
98.	1.3849442	258.25	148.	1.5771088	262.08
99.	1.3888153	258.33	149.	1.5809233	262.16
100.	1.3926852	258.40	150.	1.5847367	262.24

WESTERN STANDARDS LABORATORY
REPORT

TABLE
FOR
PLATINUM RESISTANCE THERMOMETER

CALIBRATED TO IPTS-68

SERIAL NUMBER 233

NAVAL AIR REWORK FACILITY
NAVAL AIR STATION
NORTH ISLAND

I-474

NAVAL AIR REWORK FACILITY
NAVAL AIR STATION
NORTH ISLAND
SAN DIEGO, CALIFORNIA

Western Standards Laboratory Type 1 Report of Calibration

FOR

PLATINUM RESISTANCE THERMOMETER

SUBMITTED BY:

United Technologies, Chemical Systems Division
1050 East Arques
Sunnyvale, California

Manufacturer: Minco Products, Incorporated
Model : S 1059-2
Serial : 233

This thermometer was calibrated for use with continuous current of 1.0 mA through the thermometer. The following values were found for the constants in the International Practical Temperature Scale of 1968 (IPTS-68) formulas:

<u>CONSTANT</u>	<u>VALUE</u>
Alpha (α)	3.926303×10^{-3}
Delta (δ)	1.469924
A_4	3.366389×10^{-7}
C_4	2.000000×10^{-14} (assumed)
A	3.984017×10^{-3}
B	$- 5.771367 \times 10^{-7}$
R_0	100.2662 Ω

The pertinent IPTS-68 formulas are given in the discussion on pages I-454 and I-455.

The values given were determined from measurements near 0.01°C, 25°C, and 50°C. The uncertainty of the measurements at the test points, expressed in temperature, is less than 0.01°C.

AMBIENT TEMP 23°C

RELATIVE HUMIDITY 43%

REPORT NO. UT-5

DATE 9 Jun 1977

11ND-NAVAIREWORKFAC-1000G/1 (REV. 4-77)

mck

PREPARED BY: J. F. Berlanga
APPROVED BY: C. G. Kullmann

RESUBMISSION DATE 9 Jun 1979

I-475

PLATINUM RESISTANCE THERMOMETER SER NO. 2330003

ALPHA = 0.39263034389E-02

DELTA = 0.1469424E+01

A4 = 0.3366389E+00

C4 = 0.2700000E-13

A5 = 0.3984017E-02

B0 = 0.5771367E-06

R0 = 0.1002662E+03

R1 = 0.1002702E+03

T1 = 0.0100

R2 = 0.1102217E+03

T2 = 25.0129

R3 = 0.1201754E+03

T3 = 50.0283

R4 = 0.0000000E+00

T4 = 0.0000

PLATINUM RESISTANCE THERMOMETER CALIBRATION TABLE SER NO. 2330000

TEMP. DEG.C	RESISTANCE RATIO	INVERSE DIFF	TEMP. DEG.C	RESISTANCE RATIO	INVERSE DIFF
-50.	0.7990963	246.83	0.	1.0000000	250.78
-49.	0.8031462	246.92	1.	1.0039852	251.93
-48.	0.8071947	247.00	2.	1.0079692	251.00
-47.	0.8112419	247.08	3.	1.0119520	251.08
-46.	0.8152877	247.17	4.	1.0159336	251.16
-45.	0.8193322	247.25	5.	1.0199140	251.23
-44.	0.8233753	247.33	6.	1.0238932	251.31
-43.	0.8274171	247.41	7.	1.0278712	251.38
-42.	0.8314575	247.50	8.	1.0318480	251.46
-41.	0.8354966	247.58	9.	1.0358235	251.54
-40.	0.8395344	247.66	10.	1.0397979	251.61
-39.	0.8435709	247.74	11.	1.0437711	251.69
-38.	0.8476060	247.82	12.	1.0477431	251.76
-37.	0.8516398	247.90	13.	1.0517139	251.84
-36.	0.8556723	247.99	14.	1.0556834	251.92
-35.	0.8597035	248.06	15.	1.0596518	251.99
-34.	0.8637334	248.14	16.	1.0636190	252.07
-33.	0.8677620	248.23	17.	1.0675850	252.14
-32.	0.8717893	248.30	18.	1.0715498	252.22
-31.	0.8758153	248.38	19.	1.0755134	252.30
-30.	0.8798401	248.46	20.	1.0794756	252.37
-29.	0.8838635	248.54	21.	1.0834370	252.45
-28.	0.8878857	248.62	22.	1.0873970	252.52
-27.	0.8919066	248.70	23.	1.0913558	252.60
-26.	0.8959262	248.78	24.	1.0953134	252.68
-25.	0.8999447	248.85	25.	1.0992699	252.75
-24.	0.9039617	248.94	26.	1.1032251	252.83
-23.	0.9079776	249.01	27.	1.1071791	252.91
-22.	0.9119922	249.09	28.	1.1111320	252.98
-21.	0.9160055	249.17	29.	1.1150836	253.06
-20.	0.9200176	249.25	30.	1.1190341	253.13
-19.	0.9240284	249.32	31.	1.1229834	253.21
-18.	0.9280360	249.40	32.	1.1269315	253.29
-17.	0.9320463	249.48	33.	1.1308783	253.36
-16.	0.9360535	249.55	34.	1.1348240	253.44
-15.	0.9400593	249.63	35.	1.1387686	253.52
-14.	0.9440640	249.71	36.	1.1427119	253.59
-13.	0.9480674	249.79	37.	1.1466546	253.67
-12.	0.9520696	249.87	38.	1.1505950	253.75
-11.	0.9560705	249.94	39.	1.1545347	253.82
-10.	0.9600703	250.02	40.	1.1584733	253.90
-9.	0.9640687	250.10	41.	1.1624107	253.98
-8.	0.9680660	250.17	42.	1.1663469	254.05
-7.	0.9720620	250.25	43.	1.1702819	254.13
-6.	0.9760568	250.33	44.	1.1742157	254.21
-5.	0.9800504	250.40	45.	1.1781484	254.28
-4.	0.9840427	250.48	46.	1.1820798	254.36
-3.	0.9880339	250.55	47.	1.1860101	254.44
-2.	0.9920238	250.63	48.	1.1899392	254.51
-1.	0.9960125	250.71	49.	1.1938671	254.59
0.	1.0000000	250.78	50.	1.1977938	254.67

PLATINUM RESISTANCE THERMOMETER CALIBRATION TABLE SER NO. 2330000

TEMP. DEG.C	RESISTANCE RATIO	INVERSE DIFF	TEMP. DEG.C	RESISTANCE RATIO	INVERSE DIFF
50.	1.1977938	254.67	100.	1.3926303	258.53
51.	1.2017194	254.74	101.	1.3964972	258.61
52.	1.2056437	254.82	102.	1.4003630	258.68
53.	1.2095669	254.90	103.	1.4042275	258.76
54.	1.2134889	254.97	104.	1.4080909	258.84
55.	1.2174097	255.05	105.	1.4119532	258.92
56.	1.2213294	255.13	106.	1.4158142	259.00
57.	1.2252478	255.20	107.	1.4196741	259.07
58.	1.2291651	255.28	108.	1.4235329	259.15
59.	1.2330812	255.36	109.	1.4273905	259.23
60.	1.2369961	255.43	110.	1.4312469	259.31
61.	1.2409099	255.51	111.	1.4351022	259.39
62.	1.2448224	255.59	112.	1.4389563	259.46
63.	1.2487338	255.66	113.	1.4428092	259.54
64.	1.2526440	255.74	114.	1.4466610	259.62
65.	1.2565530	255.82	115.	1.4505116	259.70
66.	1.2604609	255.89	116.	1.4543611	259.78
67.	1.2643676	255.97	117.	1.4582093	259.86
68.	1.2682731	256.05	118.	1.4620565	259.93
69.	1.2721774	256.13	119.	1.4659025	260.01
70.	1.2760805	256.20	120.	1.4697473	260.09
71.	1.2799825	256.28	121.	1.4735909	260.17
72.	1.2838833	256.36	122.	1.4774334	260.25
73.	1.2877829	256.43	123.	1.4812748	260.33
74.	1.2916814	256.51	124.	1.4851150	260.40
75.	1.2955787	256.59	125.	1.4889540	260.48
76.	1.2994748	256.67	126.	1.4927919	260.56
77.	1.3033697	256.74	127.	1.4966286	260.64
78.	1.3072635	256.82	128.	1.5004641	260.72
79.	1.3111561	256.90	129.	1.5042985	260.80
80.	1.3150475	256.98	130.	1.5081318	260.88
81.	1.3189377	257.05	131.	1.5119638	260.95
82.	1.3228268	257.13	132.	1.5157948	261.03
83.	1.3267147	257.21	133.	1.5196245	261.11
84.	1.3306015	257.29	134.	1.5234532	261.19
85.	1.3344870	257.36	135.	1.5272806	261.27
86.	1.3383714	257.44	136.	1.5311069	261.35
87.	1.3422546	257.52	137.	1.5349321	261.43
88.	1.3461367	257.60	138.	1.5387561	261.51
89.	1.3500176	257.67	139.	1.5425789	261.59
90.	1.3538973	257.75	140.	1.5464006	261.66
91.	1.3577759	257.83	141.	1.5502211	261.74
92.	1.3616533	257.91	142.	1.5540405	261.82
93.	1.3655295	257.98	143.	1.5578587	261.90
94.	1.3694045	258.06	144.	1.5616758	261.98
95.	1.3732784	258.14	145.	1.5654917	262.06
96.	1.3771511	258.22	146.	1.5693065	262.14
97.	1.3810227	258.29	147.	1.5731201	262.22
98.	1.3848931	258.37	148.	1.5769326	262.30
99.	1.3887623	258.45	149.	1.5807439	262.38
100.	1.3926303	258.53	150.	1.5845540	262.46

APPENDIX J
VISHAY RESISTOR STABILITY DATA

This appendix contains long-term stability data on Vishay resistors purchased by CSD for use on this contract as well as long-term data on resistors supplied to Bendix Corp. This appendix is included to demonstrate the stability behavior of the Vishay resistors.

Quality Control Data Sheet

Customer - United Technology P.O. No. 35-366828

F.O. 0505-238

F.C. 50910

Value: 506

Tolerance: 1%

Maximum
Response 511.060

Minimum
Response 500.940

Serial No.	Readout, Ω	-155°C to 125°C Cycle	Readout, Ω	R = PPM	168 hr Burn	Readout, Ω	R = PPM
WS 93	505.990	X	505.994	0.08	X	505.993	-0.02
94	505.968	X	505.970	0.04	X	505.971	0.02
95	505.991	X	505.993	0.04	X	505.993	0
96	505.983	X	505.983	0	X	505.982	-0.02
97	505.981	X	505.983	0.04	X	505.982	-0.02
98	505.006	X	506.007	0.02	X	506.001	-0.12
99	505.984	X	505.984	0	X	505.982	-0.04
WT 00	505.947	X	505.949	0.04	X	505.947	-0.04
01	505.995	X	505.995	0	X	505.991	-0.08
02	505.978	X	505.976	-0.04	X	505.973	-0.06
03	505.986	X	505.988	0.04	X	505.991	0.06
04	505.997	X	505.999	0.04	X	505.996	-0.06
05	505.965	X	505.965	0	X	505.961	-0.08
06	505.989	X	505.991	0.04	X	505.989	-0.04
07	505.998	X	505.998	0	X	506.002	0.08
08	505.982	X	505.982	0	X	505.979	-0.06
09	506.002	X	506.003	0.02	X	506.000	-0.06
10	505.987	X	505.988	0.02	X	505.984	-0.08
11	506.021	X	506.023	0.04	X	506.018	-0.10
12	505.986	X	505.987	0.01	X	505.981	-0.12

VISHAY ENVIRONMENTAL LAB

LAB No. 98-2	TR No.	Project No.	Department No. 403	
Originator Beaver		Part No. P/N 300231	Quantity	Date Code
		150 ± 0.1%	7	7426
		165 ± 0.1%	7	7426
		154 ± 0.1%	8	7426

Test Description: Group "C" inspected subgroup 2, test per Vishay B/P 710094 load life. FO No. 0614-418 (Bendix).

Equipment	Model No.	S/N	Calibration Due
Resistance bridge	1104	210	3/26/76
Digital multimeter	8000A	51123	7/31/75
Oven No. 10	OV490A	JT8754R	Before use
Thermometer	-	82	3/3/76

Remarks: Exceptions; (1) temperature = $60^{\circ} \pm 5^{\circ}\text{C}$, (2) duration = $2,000 \pm 48$ hr, (3) ΔR limit = 0.03% (300 ppm) and 0.1% (1,000 ppm) ABS, (4) load = 0.15 W dc

Performed by: N. Love

Date: 4/9/75

QUALITY CONTROL DATA SHEET

Customer - Bendix
 LR No. 98-2
 F.O. Equipment Monitoring Sheet
 P.O. 54-442638

Remarks: Temperature = 60°C
 Value = 4.83 VDC

Date	Observer	Time	Temperature of Oven	Voltage Load on Rack
1/14/75	N. Love	1500	60°C	4.83 VDC
1/30/75	N. Love	1530	60°C	4.83 VDC
2/7/75	N. Love	1430	62°C	5.34 VDC
2/24/75	N. Love	1520	60°C	4.83 VDC
3/18/75	N. Love	1510	60°C	4.86 VDC
3/27/75	N. Love	1520	63°C	5.04 VDC

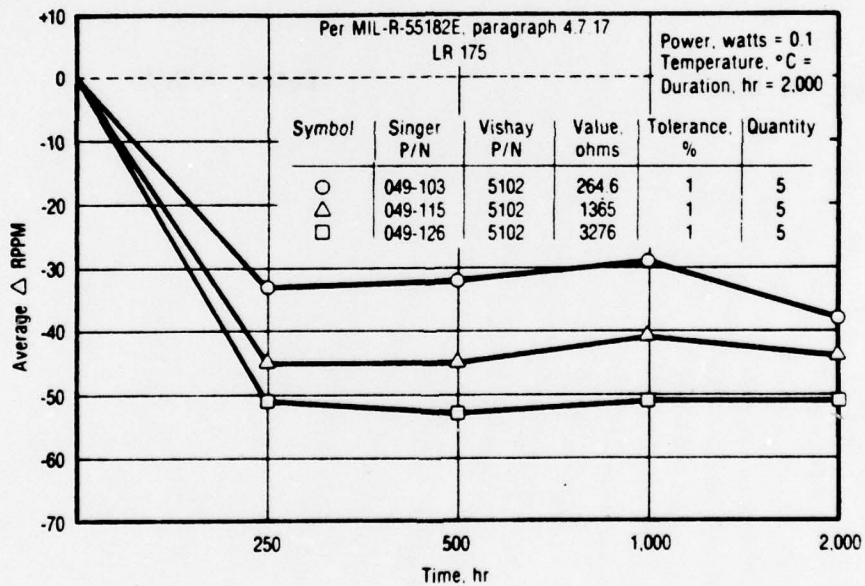

Figure J-250. Load Life

17712

J-482

Quality Control Data Sheet

Customer - Bendix
 LR No. 98-2
 F.O. 0614-518
 P.O. 54-442638

Test per Vishay B/P 710094
 Group "C" insp. subgroup 2
 Rel. 150333

Remarks: Load life duration = 2,000 ± 48 hr
 Temperature = 60° ± 5°C, P = 0.15 W
 E = 4.83 VDC, Tolerance = ±0.1%, Value*

Limits: ΔR = ±300 ppm 1 ± 1,000 ppm ABS from nominal; P/N = 300231

Value*/ Serial No.	Quantity	ΔR 250 hr, ppm	ΔR 500 hr, ppm	ΔR 1,000 hr, ppm	ΔR 2,000 hr, ppm
150Ω HT-67 to HU-11	7	Minimum Maximum Average	-50 130 10.71	-45 140 12.85	-30 160 26.42
		Defects	0	0	0
154Ω HI-13 to HI-43	8	Minimum Maximum Average	-175 0 -33.12	-20 0 -9.37	-30 20 -3.75
		Defects	0	0	0
165Ω HF-62 to HF-96	7	Minimum Maximum Average	-10 30 5	-5 25 5.71	0 10 55 26.43
		Defects	0	0	0

- Notes: (1) Minimum = Maximum negative ΔR
 (2) Maximum = Maximum positive ΔR
 (3) Average = Algebraic average
 (4) Defects not included in average

Quality Control Data Sheet

Customer - Bendix
 LR No. 98-2
 F.O. 0614-518
 P.O. 54-442638

Test per Vishay B/P 710094
 Release 150333
 Group "C" Insp. Subgroup 2

Remarks: Load life
 Temperature = $60 \pm 50^{\circ}\text{C}$
 Watts = 0.15
 Duration = $2,000 \pm 48$ hr
 Tolerance = 0.1%

Value = 150Ω
 4.83 VDC

Serial No.	R ₁ Initial	R ₂ 250 hr	(R ₂ - R ₁) ΔRPPM	R ₃ 500 hr	(R ₃ - R ₁) ΔRPPM	R ₄ 1,000 hr	(R ₄ - R ₁) ΔRPPM	R ₅ 2,000 hr	(R ₅ - R ₁) ΔRPPM
HT-67	75	70	-6	75	0	70	-5	90	15
87	-20	-70	-50	-70	-50	-65	-45	-50	-30
HT-99	270	270	0	280	10	280	10	300	30
HH-07	-30	-40	-10	-30	0	-45	-15	-40	-10
09	-75	-70	-6	-70	-0.05	-60	15	-55	20
10	-200	-70	130	-70	130	-60	140	-40	160
11	120	100	-20	100	-20	110	-10	120	0
Date	1/13/75	1/24/75	1/24/75	2/3/75	2/3/75	2/24/75	2/25/75	4/9/75	4/9/75
Time	0935	0935	0940	1445	1520	1500	0830	0800	0800
Temp/RH	75°/28%	76°/18%	76°/18%	74°/18%	74°/18%	76°/30%	78°/28%	80°/10%	

Quality Control Data Sheet

Customer - Bendix
 LR No. 98-2
 F.O. 0614-518
 P.O. 54-4426-38

Test per Vishay B/P 710094
 Release 150333
 Group "C" Insp. Subgroup 2

Remarks: Load life
 Temperature = $60 \pm 5^\circ\text{C}$
 Watts = 0.15
 Duration = $2,000 \pm 48$ hr
 Tolerance = 0.1%
 Value = 165Ω

Serial No.	R ₁ Initial	R ₂ 250 hr	(R ₂ - R ₁) ΔRPPM	R ₃ 500 hr	(R ₃ - R ₁) ΔRPPM	R ₄ 1,000 hr	(R ₄ - R ₁) ΔRPPM	R ₅ 2,000 hr	(R ₅ - R ₁) ΔRPPM
HF-62	-65	-70	-5	-70	-5	-60	-5	-40	25
73	600	630	30	600	0	600	0	610	10
76	20	25	5	35	15	50	30	65	45
80	45	60	15	55	10	60	15	70	25
86	100	100	0	100	0	110	10	110	10
87	45	45	0	70	25	85	40	100	55
96	-25	-35	-10	-30	-5	-25	0	-10	15

Date
 Time
 Temp/RH

1/13/75
 0935
 75°/28%

1/24/75
 0935
 76°/18%

2/3/75
 1500
 74°/18%

2/3/75
 1515
 74°/18%

2/24/75
 1435
 76°/30%

2/25/75
 0830
 78°/28%

4/9/75
 0800
 80°/10%

Quality Control Data Sheet

Customer - Bendix
 LR No. 98-2
 F.O. 0614-518
 P.O. 54-442638

Test per Vishay B/P 710094
 Release 150333
 Group "C" Insp. Subgroup 2

Remarks: Load life
 Temperature = 60 \pm 5 \circ C
 Watts = 0.15
 Duration = 2,000 \pm 48 hr
 Tolerance = 0.1%
 Value = 154 Ω

Serial No.	R ₁ Initial	R ₂ 250 hr	(R ₂ - R ₁) Δ RPPM	R ₃ 500 hr	(R ₃ - R ₁) Δ RPPM	R ₄ 1,000 hr	(R ₄ - R ₁) Δ RPPM	R ₅ 2,000 hr	(R ₅ - R ₁) Δ RPPM
HI-13	140	120	-20	130	-10	140	0	160	20
22	170	160	-10	170	0	180	10	180	10
23	180	160	-20	160	-20	150	-20	150	-30
31	180	180	0	170	-10	170	-10	180	0
32	230	220	-10	210	-20	220	-10	220	-10
35	100	100	0	100	0	100	0	100	0
40	330	300	-30	320	-10	320	-10	300	-30
43	90	-85	-175	85	-5	90	0	90	0

Date Time Temp/RH	R ₁ Initial	R ₂ 250 hr	(R ₂ - R ₁) Δ RPPM	R ₃ 500 hr	(R ₃ - R ₁) Δ RPPM	R ₄ 1,000 hr	(R ₄ - R ₁) Δ RPPM	R ₅ 2,000 hr	(R ₅ - R ₁) Δ RPPM
1/13/75 0935	140	120	-20	130	-10	140	0	160	20
1/24/75 0940	170	160	-10	170	0	180	10	180	10
1/24/75 0940	180	160	-20	160	-20	150	-20	150	-30
2/3/75 1515	180	180	0	170	-10	170	-10	180	0
2/3/75 1515	230	220	-10	210	-20	220	-10	220	-10
2/3/75 1515	100	100	0	100	0	100	0	100	0
2/3/75 1515	330	300	-30	320	-10	320	-10	300	-30
2/3/75 1515	90	-85	-175	85	-5	90	0	90	0
2/24/75 1435	140	120	-20	130	-10	140	0	160	20
2/24/75 1435	170	160	-10	170	0	180	10	180	10
2/24/75 1435	180	160	-20	160	-20	150	-20	150	-30
2/24/75 1435	180	180	0	170	-10	170	-10	180	0
2/24/75 1435	230	220	-10	210	-20	220	-10	220	-10
2/24/75 1435	100	100	0	100	0	100	0	100	0
2/24/75 1435	330	300	-30	320	-10	320	-10	300	-30
2/24/75 1435	90	-85	-175	85	-5	90	0	90	0
4/9/75 0800	140	120	-20	130	-10	140	0	160	20
4/9/75 0800	170	160	-10	170	0	180	10	180	10
4/9/75 0800	180	160	-20	160	-20	150	-20	150	-30
4/9/75 0800	180	180	0	170	-10	170	-10	180	0
4/9/75 0800	230	220	-10	210	-20	220	-10	220	-10
4/9/75 0800	100	100	0	100	0	100	0	100	0
4/9/75 0800	330	300	-30	320	-10	320	-10	300	-30
4/9/75 0800	90	-85	-175	85	-5	90	0	90	0
2/25/75 0830	140	120	-20	130	-10	140	0	160	20
2/25/75 0830	170	160	-10	170	0	180	10	180	10
2/25/75 0830	180	160	-20	160	-20	150	-20	150	-30
2/25/75 0830	180	180	0	170	-10	170	-10	180	0
2/25/75 0830	230	220	-10	210	-20	220	-10	220	-10
2/25/75 0830	100	100	0	100	0	100	0	100	0
2/25/75 0830	330	300	-30	320	-10	320	-10	300	-30
2/25/75 0830	90	-85	-175	85	-5	90	0	90	0
78 \circ /28%	140	120	-20	130	-10	140	0	160	20
78 \circ /28%	170	160	-10	170	0	180	10	180	10
78 \circ /28%	180	160	-20	160	-20	150	-20	150	-30
78 \circ /28%	180	180	0	170	-10	170	-10	180	0
78 \circ /28%	230	220	-10	210	-20	220	-10	220	-10
78 \circ /28%	100	100	0	100	0	100	0	100	0
78 \circ /28%	330	300	-30	320	-10	320	-10	300	-30
78 \circ /28%	90	-85	-175	85	-5	90	0	90	0
76 \circ /18%	140	120	-20	130	-10	140	0	160	20
76 \circ /18%	170	160	-10	170	0	180	10	180	10
76 \circ /18%	180	160	-20	160	-20	150	-20	150	-30
76 \circ /18%	180	180	0	170	-10	170	-10	180	0
76 \circ /18%	230	220	-10	210	-20	220	-10	220	-10
76 \circ /18%	100	100	0	100	0	100	0	100	0
76 \circ /18%	330	300	-30	320	-10	320	-10	300	-30
76 \circ /18%	90	-85	-175	85	-5	90	0	90	0
76 \circ /18%	140	120	-20	130	-10	140	0	160	20
76 \circ /18%	170	160	-10	170	0	180	10	180	10
76 \circ /18%	180	160	-20	160	-20	150	-20	150	-30
76 \circ /18%	180	180	0	170	-10	170	-10	180	0
76 \circ /18%	230	220	-10	210	-20	220	-10	220	-10
76 \circ /18%	100	100	0	100	0	100	0	100	0
76 \circ /18%	330	300	-30	320	-10	320	-10	300	-30
76 \circ /18%	90	-85	-175	85	-5	90	0	90	0
76 \circ /18%	140	120	-20	130	-10	140	0	160	20
76 \circ /18%	170	160	-10	170	0	180	10	180	10
76 \circ /18%	180	160	-20	160	-20	150	-20	150	-30
76 \circ /18%	180	180	0	170	-10	170	-10	180	0
76 \circ /18%	230	220	-10	210	-20	220	-10	220	-10
76 \circ /18%	100	100	0	100	0	100	0	100	0
76 \circ /18%	330	300	-30	320	-10	320	-10	300	-30
76 \circ /18%	90	-85	-175	85	-5	90	0	90	0
76 \circ /18%	140	120	-20	130	-10	140	0	160	20
76 \circ /18%	170	160	-10	170	0	180	10	180	10
76 \circ /18%	180	160	-20	160	-20	150	-20	150	-30
76 \circ /18%	180	180	0	170	-10	170	-10	180	0
76 \circ /18%	230	220	-10	210	-20	220	-10	220	-10
76 \circ /18%	100	100	0	100	0	100	0	100	0
76 \circ /18%	330	300	-30	320	-10	320	-10	300	-30
76 \circ /18%	90	-85	-175	85	-5	90	0	90	0

VISHAY ENVIRONMENTAL LAB

Lab No. 175 TR No. - Project No. - Department No. 20-201
 Originator - Lownes

Part No. S102	Quantity	Date Code
2646Ω	5	7512
1365Ω	5	7351
3276Ω	5	7346

Test Description: Load life, subgroup I, per MIL-R-55182E, paragraph 4.7.17 and Singer A600A049.

Equipment	Model No.	Serial No.	Calibration Due
Resistance bridge	1104	210	3/26/76
Fluke multimeter	8000A	51123	1/31/76
Power supply	Vishay	7413	Each use
Cycling box	Vishay	107	Each use
Oven	Blue "M" OV490A-2	J-3770	Each use
Power supply	Vishay	7406	Each use
Power supply	LAMBDA LH118A	02386	Each use
Thermometer		86	3/3/76

Remarks: Exceptions; (1) duration = 2,000 hr, (2) power = 0.1 W at 70°C cycling, (3) read and record at 250, 500, 1,000, and 2,000 hr, (4) ΔR limit = 75 ppm.

Performed by: N. Love

Date: 9/19/75

VISHAY RESISTIVE SYSTEMS GROUP
Environmental Lab Data Sheet

MIL-R-55182E
Method Paragraph 4.7.17
LR No. 175
E = 5.14 VDC

W = 0.1
I = 0.09720

Test: Load life (2,000 hr)
per release 150394A Group "C"
Subgroup I (S102) 049-103
Value = 264.6Ω
Tolerance = 1.0%

Serial No.	R ₁ Initial	250 hr ΔRPPM	500 hr ΔRPPM	1,000 hr ΔRPPM	2,000 hr ΔRPPM
AA-0818	264.852	-40	-35	-25	-50
0820	265.208	-40	-35	-35	-45
0821	264.907	-30	-25	-20	-20
0824	265.073	-25	-35	-35	-40
0867	264.998	-30	-30	-30	-35

By:	N. Love	N. Love	N. Love	N. Love	N. Love
Date:	6/26/75	7/8/75	7/18/75	8/8/75	9/19/75
Time:	1350	1500	1220	1540	1045
Temp/RH:	76°/26%	74°/50%	74°/55%	72°/50%	73°/55%

VISHAY RESISTIVE SYSTEMS GROUP
Environmental Lab Data Sheet

MIL-R-55182E
Method Paragraph 4.7.17
L.R. No. 175
E = 11.68

W = 0.1
I = 0.04278

Test: Load life (2,000 hr)
per release 150394A group "C"
Subgroup I (S102) 049-115
Value = 1365Ω Tolerance = 1.0%

Serial No.	R ₁ Initial	250 hr ΔRPPM	500 hr ΔRPPM	1,000 hr ΔRPPM	2,000 hr ΔRPPM
AD-419	1369.99	-30	-30	-20	-30
420	1369.95	-50	-50	-50	-50
425	1369.04	-50	-50	-50	-50
427	1369.83	-60	-60	-55	-50
428	1370.06	-35	-35	-30	-40

By:	N. Love	N. Love	N. Love	N. Love	N. Love
Date:	6/26/75	7/8/75	7/18/75	8/8/75	9/19/75
Time:	1345	1510	1210	1540	1045
Temp/RH:	76°/26%	74°/50%	74°/55%	78°/50%	73°/50%

Quality Control Data Sheet

Customer - Singer
LR No. 175

Per release 150394A
Group "C" Subgroup I
0.1 W at 70°C
ΔR tolerance = ± 75 ppm

Remarks: Load life
Value = S102, 264.6, 1365, 3276Ω
Tolerance = ±1.0%

Serial No.	Quantity Tested	Variations	Reading	All Readings in PPM from Initial		
				Maximum	Minimum	Average
AA-0818 to 0867	5	264.6Ω Singer P/N - 049-103 Date code - 7512 Flow card - 14578-1 Applied voltage - 5.14 VDC	250 hr	-40	-25	-33.0
			500 hr	-35	-25	-32.0
			1,000 hr	-35	-20	-29.0
			2,000 hr	-50	-20	-38.0
AD-419 to 428	5	1365Ω Singer P/N - 049-115 Date code - 7351 Flow card - 92949 Applied voltage - 11.68 VDC	250 hr	-60	-30	-45.0
			500 hr	-60	-30	-45.0
			1,000 hr	-55	-20	-41.0
			2,000 hr	-50	-30	-44.0
AD-481 to 497	5	3276Ω Singer P/N - 049-126 Date code - 7346 Flow card - 92950 Applied voltage - 18.09 VDC	250 hr	-65	-30	-51.0
			500 hr	-65	-30	-53.0
			1,000 hr	-65	-30	-51.0
			2,000 hr	-60	-30	-51.0

SHELF LIFE 10K 0.01% S102 RESISTOR UNMOUNTED AND INDIVIDUALLY SERIAL NUMBERED
Group A8

	1/18/66	2/28/66	$\Delta R, \Omega$	$\Delta R, (\%)$	4/5/66	$\Delta R, \Omega$	$\Delta R (\%)$
A0687	10000.1	9999.99	-0000.11	-0.0011	9999.99	-0000.11	-0.0011
88	9999.50	9998.95	-0000.55	-0.0055	9998.93	-0000.57	-0.0057
89	9999.38	9998.86	-0000.52	-0.0052	9998.90	-0000.48	-0.0048
90	9999.81	9999.20	-0000.61	-0.0061	9999.22	-0000.59	-0.0059
91	10000.3	10000.0	-00000.3	-0.0030	10000.0	-00000.3	-0.0030
92	10000.2	9999.97	-0000.23	-0.0023	9999.96	-0000.24	-0.0024
93	9999.80	9999.44	-0000.36	-0.0036	9999.39	-0000.41	-0.0041
94	10000.3	10000.0	-00000.3	-0.0030	10000.0	-00000.3	-0.0030
95	10000.2	9999.87	-0000.33	-0.0033	9999.91	-0000.29	-0.0029
96	10000.4	10000.0	-00000.4	-0.0040	10000.0	-00000.4	-0.0040
97	10000.3	10000.0	-00000.3	-0.0030	10000.0	-00000.3	-0.0030
98	9999.91	9999.59	-0000.32	-0.0032	9999.56	-0000.35	-0.0035
99	10000.3	9999.99	-0000.31	-0.0031	9999.99	-0000.31	-0.0031
700	10000.4	10000.0	-00000.4	-0.0040	10000.1	-00000.3	-0.0030
01	10000.5	10000.0	-00000.5	-0.0050	10000.0	-00000.5	-0.0050
02	10000.3	10000.0	-00000.3	-0.0030	10000.0	-00000.3	-0.0030
03	10000.0	9999.54	-0000.46	-0.0046	9999.57	-0000.43	-0.0043
04	10000.4	10000.1	-00000.3	-0.0030	10000.1	-00000.3	-0.0030
05	10000.1	9999.99	-0000.11	-0.0011	9999.99	-0000.11	-0.0011
06	9999.53	9999.09	-0000.44	-0.0044	9999.13	-0000.40	-0.0040
07	10000.0	9999.80	-0000.20	-0.0020	9999.77	-0000.23	-0.0023
08	10000.3	9999.99	-0000.31	-0.0031	9999.99	-0000.31	-0.0031
09	9999.80	9999.19	-0000.61	-0.0061	9999.18	-0000.62	-0.0062
10	10000.1	9999.79	-0000.31	-0.0031	9999.99	-0000.11	-0.0011
11	10000.3	9999.99	-0000.31	-0.0031	9999.99	-0000.31	-0.0031
12	10000.4	10000.0	-00000.4	-0.0040	10000.0	-00000.4	-0.0040
13	9999.30	9998.92	-0000.38	-0.0038	9999.00	-0000.30	-0.0030
14	10000.3	9999.88	-0000.42	-0.0042	9999.92	-0000.38	-0.0038
15	10000.4	10000.0	-00000.4	-0.0040	10000.0	-00000.4	-0.0040
16	9999.98	9999.70	-0000.28	-0.0028	9999.74	-0000.24	-0.0024
17	10000.3	9999.95	-0000.35	-0.0035	9999.99	-0000.31	-0.0031
18	9999.70	9999.20	-0000.50	-0.0050	0000.18	-0000.52	-0.0052
19	9999.99	9999.65	-0000.34	-0.0034	9999.71	-0000.28	-0.0028
20	9999.61	9998.99	-0000.62	-0.0062	9999.03	-0000.58	-0.0058
21	9999.49	0000.11	-0000.38	-0.0038	9999.13	-0000.36	-0.0036
22	9999.68	9999.11	-0000.57	-0.0057	9999.04	-0000.64	-0.0064
23	9999.77	9999.32	-0000.45	-0.0045	9999.37	-0000.40	-0.0040
24	9999.80	9999.02	-0000.78	-0.0078	9999.00	-0000.80	-0.0080
25	9999.97	9999.45	-0000.52	-0.0052	9999.51	-0000.46	-0.0046
26	9999.72	9999.36	-0000.36	-0.0036	9999.33	-0000.39	-0.0039
27	10000.5	10000.2	-00000.3	-0.0030	10000.3	-00000.2	-0.0020
28	9999.75	9999.22	-0000.53	-0.0053	9999.20	-0000.55	-0.0055
29	9999.71	9999.50	-0000.21	-0.0021	9999.55	-0000.16	-0.0016
30	10000.0	9999.62	-0000.38	-0.0038	9999.62	-0000.38	-0.0038
31	10000.1	9999.71	-0000.39	-0.0039	9999.69	-0000.41	-0.0041
32	9999.99	9999.65	-0000.34	-0.0034	9999.62	-0000.37	-0.0037
33	9999.70	9999.14	-0000.56	-0.0056	9999.10	-0000.60	-0.0060
34	9999.97	9999.40	-0000.57	-0.0057	9999.46	-0000.51	-0.0051
35	10000.3	9999.84	-0000.46	-0.0046	9999.83	-0000.47	-0.0047
36	9999.78	9999.28	-0000.50	-0.0050	9999.25	-0000.53	-0.0053
37	9999.80	9999.30	-0000.50	-0.0050	9999.27	-0000.53	-0.0053

Shelf Life - Group A8; 10K, 0.01%, 5102, 51 Units

	5/20/66	$\Delta R, \Omega$	$\Delta R, \%$	12/19/66	$\Delta R, \Omega$	$\Delta R, \%$
A0687	9999.98	-0000.12	-0.0012	9999.99	-0000.11	-0.0011
88	9998.94	-0000.56	-0.0056	9998.78	-0000.72	-0.0072
89	9998.91	-0000.47	-0.0047	9998.84	-0000.54	-0.0054
90	9999.25	-0000.36	-0.0036	9999.06	-0000.75	-0.0075
91	10000.0	-0000.30	-0.0030	10000.0	-0000.30	-0.0030
92	9999.96	-0000.24	-0.0024	9999.88	-0000.32	-0.0032
93	9999.44	-0000.36	-0.0036	9999.44	-0000.36	-0.0036
94	10000.0	-0000.30	-0.0030	9999.96	-0000.34	-0.0034
95	9999.92	-0000.28	-0.0028	9999.86	-0000.34	-0.0034
96	10000.1	-0000.30	-0.0030	10000.1	-0000.30	-0.0030
97	10000.0	-0000.30	-0.0030	9999.99	-0000.31	-0.0031
98	9999.59	-0000.32	-0.0032	9999.42	-0000.49	-0.0049
99	9999.99	-0000.31	-0.0031	9999.99	-0000.31	-0.0031
700	10000.1	-0000.30	-0.0030	10000.1	-0000.30	-0.0030
01	10000.0	-0000.50	-0.0050	10000.0	-0000.50	-0.0050
02	10000.0	-0000.30	-0.0030	10000.0	-0000.30	-0.0030
03	9999.59	-0000.41	-0.0041	9999.43	-0000.57	-0.0057
04	10000.1	-0000.30	-0.0030	10000.1	-0000.30	-0.0030
05	10000.0	-0000.10	-0.0010	9999.97	-0000.13	-0.0013
06	9999.13	-0000.40	-0.0040	9999.06	-0000.47	-0.0047
07	9999.76	-0000.24	-0.0024	9999.69	-0000.31	-0.0031
08	9999.99	-0000.31	-0.0031	9999.98	-0000.32	-0.0032
09	9999.29	-0000.51	-0.0051	9999.08	-0000.72	-0.0072
10	9999.99	-0000.11	-0.0011	9999.97	-0000.13	-0.0013
11	9999.99	-0000.31	-0.0031	9999.94	-0000.36	-0.0036
12	10000.0	-0000.40	-0.0040	9999.99	-0000.41	-0.0041
13	9999.16	-0000.14	-0.0014	9998.83	-0000.47	-0.0047
14	9999.95	-0000.35	-0.0035	9999.88	-0000.42	-0.0042
15	10000.0	-0000.40	-0.0040	1000.00	-0000.40	-0.0040
16	9999.87	-0000.11	-0.0011	9999.63	-0000.35	-0.0035
17	9999.99	-0000.31	-0.0031	9999.90	-0000.40	-0.0040
18	9999.17	-0000.53	-0.0053	9999.06	-0000.64	-0.0064
19	9999.69	-0000.30	-0.0030	9999.67	-0000.32	-0.0032
20	9999.08	-0000.53	-0.0053	9998.82	-0000.79	-0.0079
21	9999.13	-0000.36	-0.0036	9999.05	-0000.44	-0.0044
22	9999.15	-0000.53	-0.0053	9998.92	-0000.76	-0.0076
23	9999.39	-0000.36	-0.0036	9999.25	-0000.52	-0.0052
24	9999.09	-0000.71	-0.0071	9998.80	-0001.00	-0.0100
25	9999.58	-0000.39	-0.0039	9999.39	-0000.58	-0.0058
26	9999.33	-0000.39	-0.0039	9999.25	-0000.47	-0.0047
27	10000.3	-0000.20	-0.0020	10000.3	-0000.20	-0.0020
28	9999.22	-0000.53	-0.0053	9999.11	-0000.64	-0.0064
29	9999.56	-0000.15	-0.0015	9999.52	-0000.19	-0.0019
30	9999.62	-0000.38	-0.0038	9999.58	-0000.42	-0.0042
31	9999.76	-0000.34	-0.0034	9999.65	-0000.45	-0.0045
32	9999.62	-0000.37	-0.0037	9999.57	-0000.42	-0.0042
33	9999.17	-0000.53	-0.0053	9999.05	-0000.65	-0.0065
34	9999.49	-0000.48	-0.0048	9999.46	-0000.51	-0.0051
35	9999.85	-0000.45	-0.0045	9999.72	-0000.58	-0.0058
36	9999.27	-0000.51	-0.0051	9999.19	-0000.59	-0.0059
37	9999.32	-0000.48	-0.0048	9999.18	-0000.62	-0.0062
38	9999.82	-	-	9999.71	-	-

Shelf Life; 10K, 0.01%, 13,800 hours

	3/2/67	$\Delta R, \Omega$	$\Delta R, \%$	9/5/67	$\Delta R, \Omega$	$\Delta R, \%$	9/6/68	$\Delta R, \Omega$	$\Delta R, \%$
A0687	9999.98	-0000.12	-0.0012	10000.2	00000.1	0.0010	10000.2	00000.1	0.0010
88	9999.80	-0000.70	-0.0070	9999.37	-0000.13	-0.0013	9999.10	-0000.40	-0.0040
89	9999.88	-0000.50	-0.0050	9999.42	0000.04	0.0004	9999.17	-0000.21	-0.0021
90	9999.09	-0000.72	-0.0072	9999.90	0000.09	0.0009	9999.78	-0000.03	-0.0003
91	10000.0	-00000.3	-0.0030	10000.3	-	-	10000.4	00000.1	0.0010
92	9999.82	-0000.38	-0.0038	10000.1	-00000.1	-0.0010	10000.1	-00000.1	-0.0010
93	9999.42	-0000.38	-0.0038	20000.0	0000.20	0.0020	Unstable	-	-
94	9999.99	-0000.31	-0.0031	10000.3	-	-	10000.5	00000.2	0.0020
95	9999.89	-0000.31	-0.0031	10000.2	0000.90	-	10000.2	-	-
96	10000.0	-00000.4	-0.0040	10000.4	-	-	10000.5	00000.1	0.0010
97	9999.99	-0000.31	-0.0031	10000.3	-	-	10000.3	-	-
98	9999.47	-0000.44	-0.0044	9999.92	0000.01	0.0001	9999.70	-0000.21	-0.0021
99	9999.97	-0000.33	-0.0033	10000.2	-00000.1	-0.0010	10000.4	00000.1	0.0010
700	10000.1	-00000.3	-0.0030	10000.5	00000.1	0.0010	Missing	-	-
01	10000.0	-00000.5	-0.0050	10000.5	-	-	10000.4	-00000.1	-0.0010
02	9999.99	-0000.31	-0.0031	10000.3	-	-	10000.3	-	-
03	9999.48	-0000.52	-0.0052	10000.1	00000.1	0.0010	10000.1	00000.1	0.0010
04	10000.1	-00000.3	-0.0030	10000.5	00000.1	0.0010	10000.7	00000.3	0.0030
05	9999.95	-0000.15	-0.0015	10000.2	00000.1	0.0010	10000.2	00000.1	0.0010
06	9999.08	-0000.45	-0.0045	9999.62	0000.09	0.0009	9999.32	-0000.21	-0.0021
07	9999.67	-0000.33	-0.0033	10000.0	-	-	9999.95	-0000.05	-0.0005
08	9999.99	-0000.31	-0.0031	10000.3	-	-	10000.2	-00000.1	-0.0010
09	9999.16	-0000.64	-0.0064	10000.0	0000.20	0.0020	9999.63	-0000.17	-0.0017
10	9999.99	-0000.11	-0.0011	10000.4	00000.3	0.0030	10000.3	00000.2	0.0020
11	9999.90	-0000.20	-0.0020	10000.2	-00000.1	-0.0010	10000.2	-00000.1	-0.0010
12	10000.0	-00000.4	-0.0040	10000.4	-	-	10000.3	-00000.1	-0.0010
13	9999.94	-0000.36	-0.0036	9999.50	0000.20	0.0020	9999.50	0000.20	0.0020
14	9999.93	-0000.37	-0.0037	10000.3	-	-	10000.2	-00000.1	-0.0010
15	10000.0	-00000.4	-0.0040	10000.4	-	-	10000.3	-00000.1	-0.0010
16	9999.67	-0000.31	-0.0031	10000.0	00000.2	0.0020	10000.1	0000.12	0.0012
17	9999.92	-0000.38	-0.0038	10000.3	-	-	10000.2	-00000.1	-0.0010
18	9999.07	-0000.63	-0.0063	9999.56	-0000.14	-0.0014	9999.35	-0000.35	0.0035
19	9999.65	-0000.34	-0.0034	10000.0	0000.01	0.0001	9999.75	-0000.24	-0.0024
20	9999.89	-0000.72	-0.0072	9999.50	-0000.11	-0.0011	9999.09	-0000.52	0.0052
21	9999.00	-0000.49	-0.0049	9999.46	-0000.03	-0.0003	9999.20	-0000.29	-0.0029
22	9998.96	-0000.72	-0.0072	9999.78	0000.10	0.0010	9999.70	0000.02	0.0002
23	9999.23	-0000.54	-0.0054	9999.85	0000.08	0.0008	9999.54	-0000.23	-0.0023
24	9998.92	-0000.88	-0.0088	9999.95	0000.15	0.0015	9999.80	-	-
25	9999.40	-0000.57	-0.0057	10000.0	0000.03	0.0003	10000.0	0000.03	0.0003
26	9999.21	-0000.51	-0.0051	9999.73	0000.01	0.0001	9999.50	-0000.22	-0.0022
27	10000.3	-00000.2	-0.0020	10000.8	00000.3	0.0030	10000.6	00000.1	0.0010
28	9999.12	-0000.63	-0.0063	9999.69	-0000.06	-0.0006	9999.55	-0000.20	-0.0020
29	9999.46	-0000.25	-0.0025	9999.71	-	-	9999.80	0000.09	0.0009
30	9999.55	-0000.45	-0.0045	10000.0	-	-	10000.6	00000.6	0.0060
31	9999.66	-0000.44	-0.0044	10000.2	00000.1	0.0010	10000.4	00000.3	0.0030
32	9999.55	-0000.44	-0.0044	9999.89	-0000.10	-0.0010	9999.80	-0000.19	-0.0019
33	9999.08	-0000.62	-0.0062	9999.79	0000.09	0.0009	10001.7	0001.71	0.0171
34	9999.42	-0000.55	-0.0055	10000.1	0000.04	0.0004	9999.60	-0000.37	-0.0037
35	9999.75	-0000.55	-0.0055	10000.3	-	-	10000.3	-	-
36	9999.20	-0000.58	-0.0058	9999.75	-0000.03	-0.0003	9999.48	-0000.38	-0.0038
37	9999.21	-0000.59	-0.0059	9999.83	0000.03	0.0003	9999.70	-0000.10	-0.0010
38	9999.70	-	-	10000.2	-	-	10000.0	-	-

Shelf Life at 60°C, Group A8; 0.01%, 5102

	8/2/71 48692 hr	$\Delta R, \Omega$	$\Delta R, \%$	10/24/73 68192 hr	$\Delta R, \Omega$	$\Delta R, \%$	8/1/75 83520 hr	$\Delta R, \Omega$	$\Delta R, \%$
A0687	10000.4	00000.3	0.0030	10000.0	-00000.1	-0.0010	10000.2	0.10	0.0010
88	9999.36	-0000.14	-0.0014	9998.71	-0000.79	-0.0079	10000.1	0.60	0.0060
89	9999.37	-0000.01	-0.0001	9998.87	-0000.51	-0.0051	9998.43	-0.45	-0.0040
90	9999.95	0000.14	0.0014	9999.19	-0000.62	-0.0062	9999.10	-0.71	-0.0070
91	10000.5	00000.2	0.0020	10000.2	-00000.1	-0.0010	10000.2	-0.10	-0.0010
92	10000.3	00000.1	0.0010	9999.89	-0000.31	-0.0031	9999.93	-0.27	-0.0020
93	10000.0	0000.20	0.0020	9999.45	-0000.35	-0.0035	9999.60	-0.20	-0.0020
94	10000.5	00000.2	0.0020	1000.20	-00000.1	-0.0010	10000.5	0.20	0.0020
95	10000.4	00000.2	0.0020	9999.93	-0000.27	-0.0027	9999.75	-0.45	-0.0040
96	10000.7	00000.3	0.0030	1000.40	-	-	10000.5	0.10	0.0010
97	10000.5	00000.2	0.0020	10000.1	-00000.2	-0.0020	10000.1	-0.20	-0.0020
98	9999.74	-0000.17	-0.0017	9999.38	-0000.53	-0.0053	9999.53	-0.38	-0.0030
99	10000.3	-	-	10000.0	-00000.3	-0.0030	10000.1	-0.20	-0.0020
700									
01	10000.7	00000.2	0.0020	10000.3	-00000.2	-0.0020	10000.3	-0.20	-0.0020
02	10000.4	00000.1	0.0010	10000.1	-00000.2	-0.0020	10000.1	-0.20	-0.0020
03	10000.3	00000.3	0.0030	9999.78	-0000.22	-0.0022	9999.73	-0.27	-0.0027
04	10000.8	00000.4	0.0040	10000.5	00000.1	0.0010	10000.6	0.20	0.0020
05	10000.3	00000.2	0.0020	9999.97	-0000.13	-0.0013	10000.1	-	-
06	9999.60	0000.07	0.0007	9999.03	-0000.50	-0.0050	9999.16	-0.37	-0.0030
07	10000.1	00000.1	0.0010	9999.77	-0000.23	-0.0023	9999.95	-0.05	-
08	10000.5	00000.2	0.0020	10000.1	-00000.2	-0.0020	10000.1	-0.20	-0.0020
09	9999.98	0000.18	0.0018	9999.11	-0000.69	-0.0069	9999.24	-0.56	-0.0056
10	10000.7	0000.60	0.0060	9999.97	-0000.13	-0.0013	10000.2	0.10	0.0010
11	10000.3	-	-	9999.83	-0000.47	-0.0047	10000.0	-	-
12	10000.7	0000.30	0.0030	10000.2	-00000.2	-0.0020	10000.3	-0.01	-0.0010
13	9999.27	-0000.03	-0.0003	9998.89	-0000.41	-0.0041	9998.88	-0.42	-0.0042
14	10000.6	0000.30	0.0030	9999.92	-0000.38	-0.0038	9999.96	-0.34	-0.0034
15	10000.6	0000.20	0.0020	10000.1	-00000.3	-0.0030	10000.2	-0.20	-0.0020
16	10000.2	0000.22	0.0022	9999.61	-0000.37	-0.0037	9999.59	-0.39	-0.0039
17	10000.5	0000.20	0.0020	9999.83	-0000.47	-0.0047	9999.84	-0.46	-0.0046
18	9999.45	-0000.25	-0.0025	9998.99	-0000.71	-0.0071	9999.11	-0.59	-0.0059
19	9999.90	-0000.09	-0.0009	9999.59	-0000.40	-0.0040	9999.82	-0.17	-0.0017
20	9999.38	-0000.23	-0.0023	9998.72	-0000.89	-0.0089	9998.93	-0.68	-0.0068
21	9999.20	-0000.29	-0.0029	9998.84	-0000.65	-0.0065	9998.53	-0.96	-0.0096
22	9999.71	0000.03	0.0003	9998.97	-0000.71	-0.0071	9998.95	-0.73	-0.0073
23	9999.74	-0000.03	-0.0003	9999.22	-0000.55	-0.0055	9999.17	-0.60	-0.0060
24	10000.3	0000.50	0.0050	9998.96	-0000.84	-0.0084	9998.95	-0.85	-0.0085
25	10000.3	0000.33	0.0033	9999.51	-0000.46	-0.0046	9999.58	-0.39	-0.0035
26	9999.56	-0000.16	-0.0016	9999.31	-0000.41	-0.0041	9999.47	-0.25	-0.0025
27	10000.8	0000.30	0.0030	10000.4	-00000.1	-0.0010	10000.8	0.30	0.0030
28	9999.63	-0000.12	-0.0012	9999.07	-0000.68	-0.0068	9999.18	-0.57	-0.0057
29	9999.46	-0000.25	-0.0025	9999.51	-0000.70	-0.0070	9999.63	-0.08	-0.0080
30	9999.97	-0000.03	-0.0003	9999.51	-0000.49	-0.0049	9999.71	-0.29	-0.0029
31	10000.4	0000.30	0.0030	9999.60	-0000.50	-0.0050	9999.75	-0.35	-0.0035
32	9999.75	-0000.24	-0.0024	9999.59	-0000.40	-0.0040	9999.	-0.28	-0.0028
33	9999.68	-0000.02	-0.0002	9998.99	-0000.71	-0.0071	9999.04	-0.66	-0.0066
34	10000.1	0000.13	0.0013	9999.46	-0000.51	-0.0051	9999.68	-0.29	-0.0029
35	10000.6	0000.30	0.0030	9999.89	-0000.41	-0.0041	10000.0	-0.30	-0.0030
36	9999.63	-0000.15	-0.0015	9999.14	-0000.64	-0.0064	9999.	-0.48	-0.0048
37	9999.73	-0000.07	-0.0007	9999.11	-0000.69	-0.0069	9999.14	-0.64	-0.0064
38	10000.3	0000.48	0.0048	9999.59	-	-	9999.63	-0.19	-0.0019

APPENDIX K

INSTRUMENTED BEAM TEST PROCEDURE AND
TROUBLESHOOTING GUIDE

K-499

ILLUSTRATIONS

Figure		Page
K-251	Constant Moment Beam Apparatus and Strain Gage Location	K-501
K-252	Strapping Sequence for Multimeter Input Jacks	K-504
K-253	Lead Wire Attachment on Multimeter Input Jacks	K-504
K-254	Platinum Resistor Lead Wire Attachments to Multimeter Input Jacks	K-506
K-255	Lead Wire Attachments to Multimeter for Resistance Measurement	K-506
K-256	Lead Wire Connections to Standard Resistors	K-507

PROCEDURE FOR DATA ACQUISITION FROM THE BEAM STABILITY TEST

The following includes: Part I, a brief description of the theory and the physical setup behind this test; Part II, a recommended procedure for data acquisition; and Part III, a brief trouble shooting guide to avoid erroneous data readings.

I. Theory and Setup

In the production of certain types of transducers, a strain gage is epoxied to a diaphragm, housed in the transducer casing. The strain gage is connected to form one arm of the Wheatstone bridge, so that when a pressure is applied to the diaphragm, the resistance through the strain gage changes due to deformation, and the Wheatstone bridge gives an appropriate output. A major problem hindering the accuracy of this type of transducer is the lack of understanding concerning the stability of the diaphragm, epoxy, strain gage interface with regard to such factors as aging, epoxy creep, temperature and fatigue.

In this test a special, cantilevered, constant stress beam (often referred to as a constant moment beam) has been substituted for the diaphragm mentioned above, and the applied pressure has been simulated by a 250 gm weight, loaded on the free end of the beam. The strain gages are epoxied to the beam on both the top and bottom (i.e., tension and compression) side, as shown in Figure K-251.

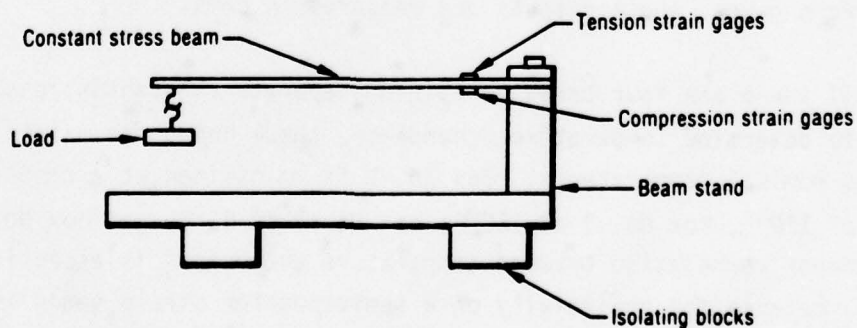

Figure K-251. Constant Moment Beam Apparatus and Strain Gage Location

17713

There are ten semiconductor strain gages, and one reference foil strain gage bonded to each side of the beam, making for a total of twenty-two bonded gages per beam. The electrical readings from these strain gages are controlled by two of three switches mounted on the door of each conditioning box. Switch No. 1, labeled SW-1, controls the gages in tension, with positions 1 through 10 being the semiconductor strain gages, and the 11th a blank position (between the 10th and the off positions) being the reference foil strain gage. Switch No. 2 controls the compression gages, again with positions 1 through 10 being the semiconductor gages, and the 11th position being the foil gage. It should be noted that these switches are in series from one switch to another, and also from one box to another box. Thus if two or more switches are left on, then the outputs will superimpose, leading to an erroneous reading. Therefore particular care should be taken to ensure that all switches, other than the one being read, are in the off position (i.e., so that the white dots are in alignment).

In addition to the bonded strain gages, there are, on switch No. 3, positions 1 and 2, two 506 ohm resistors, in Wheatstone bridges similar to those containing the semiconductor gages. These are used for standardization, and their output is measured in millivolts. Also on switch No. 3, positions 3 through 5, there are 2 standard 10Ω resistors, 2 standard $1,500\Omega$ resistors, and 2 standard $50,000\Omega$ resistors. These standards are used as calibration checks on the electrical connections and the Fluke meter. These restrictors are mounted to the interior of each insulated conditioning box, and are separate from the beams. Finally, in boxes No. 2 and No. 3 (nominal temperature 160°F and 90°F) on switch No. 3, position No. 9, there are unbonded semiconductor strain gages, whose outputs are measured in ohms.

In all there are four boxes containing separate constant stress beams. In order to determine temperature dependence, these boxes are maintained at various nominal temperatures. Box No. 1 is maintained at a nominal temperature of 120°F , box No. 2 at 160°F , box No. 3 at 90°F , and box No. 4 at -65°F . Proper correlation between temperature and output is essential to this test, because the resistivity of a semiconductor strain gages is highly temperature sensitive. Therefore a highly accurate platinum resistance

thermometer is used to measure the temperature to within $\pm 0.02^\circ\text{F}$ of the actual temperature of the constant stress beams.

Before the beams are loaded, preliminary data is taken with regard to preload stress, temperature cycles, and excitation levels. All data taken after the beams are loaded, is referenced to the moment of initial loading. This is done in order to eliminate the effects of temperature fluctuations, and in order to detect further strain due to creep, after the initial elastic strain has taken place. A detailed procedure to obtain this data follows in Part II.

II. Procedure for Data Acquisition

Before data should be taken, the headings at the top of the data acquisition forms should be filled out. The time should include whether it is AM or PM. The room temperature is read off the "Precision Digital," which is located above the Master Electrical Control. The beam S/N as well as the nominal temperature can be found on a label attached to each oven or freezer. The platinum resistor S/N is printed on a flag attached to the No. 1 lead of the platinum resistor. Finally, the data set can be found from the data form, which is kept in an individual binder for each nominal temperature. The data set numbers are sequential, and the number you write down should be one greater than the previous number on the data form.

With this completed, the Fluke multimeter should be zeroed. This is achieved by first depressing the $\overline{\text{DCV}}$ function key on the multimeter; next the Range should be put on the auto, and left there for the remainder of the test. Now the input terminals on the multimeter need to be brought to a common voltage potential. This is done by first ensuring that the guard on the multimeter is in contact with the guard on the Master Electrical Control, via a wire lead, and left in contact for the remainder of the test. Next the metal straps should be positioned as shown in Figure K-252. The multimeter should read $\pm 0\text{V}$; if it does not, then the DC zero adjustment screw needs to be set with a small screwdriver.



Figure K-252. Strapping Sequence for Multimeter Input Jacks

17714

Remove the strap linking the red with the black terminals, as in Figure K-252B. You are not ready to read the excitation current. This current excitation is used only as a monitor on the system, in order to ensure that the electronics of the test are behaving properly. Unless the voltage drop is equal to 1.02179 ± 0.00010 V, some change has occurred, and correlation with past data will be reduced. Since this reading is only a monitor, only one switch position per box, need be recorded. This reading is recorded in the far left column, headed REMARKS (Conts. Curr Mon). To read this data, attach two leads (one red, one black) to the respective red and black terminal posts marked EXC CUR, on the Master Electrical Control. Attach the other end to the left terminal posts on the multimeter, as in Figure K-253.

Whenever reading voltages, the leads should always be connected as above, in order to help balance the internal electronics of the multimeter. Now check to see that the function key is on \overline{DCV} , that the Master Electrical Control mode switch is on constant current, then turn switch No. 1 (thoses switches are mounted on the front of the ovens), box No. 1, to gage No. 1, and record the reading. Now turn this switch off, and proceed in a like manner with boxes Nos. 2, 3, and 4.

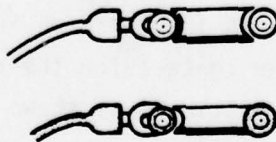

Figure K-253. Lead Wire Attachment on Multimeter Input Jacks

17715

K-504

The next step is to check the bridge output with no excitation. Move the lead from EXC CUR to OUTPUT. Now leave the function key on $\overline{\text{DCV}}$, and put the mode switch to the off position, also check to see that all the switches controlling the gages are in the off position. Flip through the gage switches, one by one, being sure to turn each switch to the off position before going on to the next switch. If all the readings are within the range of ± 0.002 mV then no data need be taken. If the readings are outside that range, then the appropriate data should be recorded in the column headed BRIDGE O.P. No EXCIT, mV. All the boxes may be read at this time.

Once this is completed, the voltage excitation should be measured. The voltage excitation varies from gage to gage; therefore the reading from each gage needs to be taken. Reading the voltage excitation is also the easiest way to recognize a broken gage. Unless the voltage excitation is equal to 1.000000 ± 0.05000 V, then the gage is probably bad, and no data should be recorded from it. In order to read voltage excitation, leave the leads on the multimeter as they are, and move the ends connected to the Master Electrical Control from OUTPUT to EXC VOLT. Now check to ensure that the multimeter is on $\overline{\text{DVC}}$, that the mode is on constant current, and that the switches controlling the gages are all in the off position.

Data for voltage excitation should only be read from one box, before going on to read temperature and output. Fill in this data in the column headed BRIDGE VOLTAGE, volts, by proceeding down the page, turning to each gage in succession.

Following the voltage excitation reading, the platinum resistor reading should be taken. The platinum resistor leads are four blue and white wires extending from the oven door, and they should be attached to the multimeter as shown in Figure K-254.

Change the function key to $K\Omega$, and note the time in the time column, then record one platinum resistor reading in the column head PLATINUM RESISTOR, ohms. Now remove the platinum resistor leads, put the straps back as in Figure K-252; change the function key to $\overline{\text{DCV}}$, put the mode switch on constant

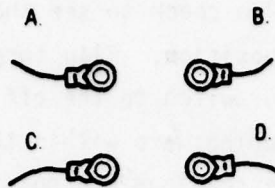

Figure K-254. Platinum Resistor Lead Wire Attachments to Multimeter Input Jacks

17716

current, and attach leads from the multimeter to the terminals marked OUTPUT, on the Master Electrical Control. Now again record the time in the time column, and read the outputs from that box, i.e., switch 1, positions 1 through 11; switch 2, positions 1 through 11, and switch 3, positions 1 and 2. Now again record the time, and take an additional platinum resistor reading, as described before. Proceed to the other boxes, taking voltage excitation, platinum resistor, and output readings.

You are now ready to read the 10Ω , $1,500\Omega$, and $50,000\Omega$ resistors. Take four leads and connect them to the four terminals marked RESISTANCE, on the Master Electrical Control. Connect the other ends to the multimeter, as shown in Figure K-255.

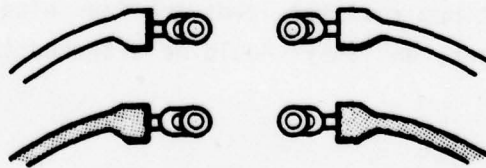

Figure K-255. Lead Wire Attachments to Multimeter for Resistance Measurement

17717

K-506

Depress the $K\Omega$ key on the multimeter, turn the mode switch to off, and check to see that all gage switches are off. Turn switch 3 to positions 3 through 9 in succession, and record the data under the heading RESISTANCE, at the bottom of the page. All the boxes may be read at this time.

Finally, the standard calibration resistor readings need to be recorded on a separate data acquisition form titled DIGITAL VOLTMETER CALIBRATION CHECK. First fill in the date, time, room temperature, and Fluke serial number, as well as whether the meter has been DC zeroed. Then leaving the lead connected to the Fluke multimeter as they are (e.g., Figure K-255), move the other ends from the Master Electrical Control, to the standard resistors, as shown in Figure K-256, and record the data in the appropriate column.

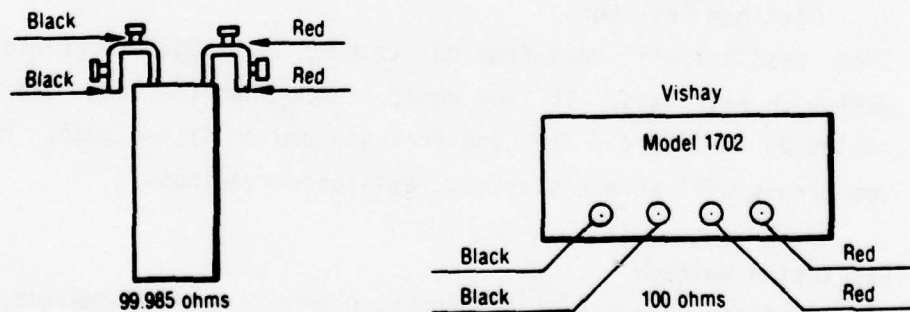

Figure K-256. Lead Wire Connections to Standard Resistors

17718

III. A Brief Guide to Trouble Shooting

A. Resistors

1. 10Ω , $1,500\Omega$, and $50,000\Omega$ resistors:

10Ω resistor should read 10.000 ± 0.500

$1,500\Omega$ resistor should read $1,500.000 \pm 10.00$

$50,000\Omega$ resistor should read $50,000 \pm 1,300$

If these resistors do not read as above, then check to see that the excitation mode switch is off, that the function key on the DVM is on K, that the straps are off, that four leads are used, and the DMM range is on auto. If the problem still persists, see "System Errors" below.

2. 100Ω Standard Calibration Resistors:

100Ω resistor should read 100.00 ± 0.060

Check that the DVM is on auto and on $K\Omega$, no "System Errors" should affect these readings. Also the Vishay resistor tends to make a bad connection with the leads. It helps to pull the leads away from the terminal post, so that the spade lug is no longer touching the actual stem.

3. Platinum Resistors

These readings will vary from box to box, but should correlate very well with past data. If they don't, check that the leads are connected as in figure K-254 and that you are on $K\Omega$ and auto. No system errors will affect platinum resistance readings.

B. Excitation Voltage

Excitation voltage should read $1.000000V \pm 0.05000V$. If it doesn't, check to see that the straps are shorting out the two red terminals, and the two black terminals as shown in Figure K-252. Check that the function key is on DCV, and that the power mode switch is on constant current; if these don't correct the problem, then see "System Errors" below.

C. Output

The best way to tell whether an output reading is bad or not, is to compare it with past readings. For output readings, the straps should be up, constant current turned on, function key on $\overline{\text{DCV}}$, and range on 200 mV dc or auto. For further guidance see System Errors.

D. System Errors

1. Common Ground

A lead should be used at all times to connect the guard on the Fluke meter with the guard on the Master Electrical Control. While this guard has no effect on resistance readings, it is essential when reading voltages, in order than a common ground state is used.

2. Fluke Meter

Be sure that the Fluke meter has been turned on for at least two hours before the readings. Also be sure that the DC zero has been properly zeroed.

3. Shorting Out Leads

If more than one set of two leads are used at a time (e.g., EXC VOLT and OUTPUT are hooked up at the same time) then the possibility exists that while reading from one set of leads, the red and black leads of the other set are in contact with each other and are shorting out the system. If EXC VOLT is shorted out, then no Output will read anywhere near the proper value. However, if the Output leads are shorted, then excitation voltage will be changed by about $\pm 0.0005\text{V}$; this is an important change, but may go unnoticed unless due care is taken.

4. More than One Switch On

Last, but probably most important, is the possibility that if more than one switch in series is on, then the gage readings will be superimposed. This applies to both resistance and voltage readings. Particular care should be taken to inspect the switches controlling the freezer as well as the ovens.

EPOXY CREEP EVALUATION TEST DESIGN

Circuit Design

<u>Potential Problem</u>	<u>Design Solution</u>
Line resistance changes with age and temperature causing zero shift and sensitivity shift	Three-wire circuit to balance resistance change in bridge; all three wires are switched together Wire gage selector switch wiper with No. 18 AWG Short leads to gage selector switches Provide shunt calibration check
Gage selector switch contact resistance changes	Switches are of low and stable contact resistance and low thermals design (Leeds & Northrup P/N 31264)
Common mode voltage causes "noisy" readout	Short length of unshielded wires from temperature box to switches Tie shields from switches, power supply and completion resistors to DVM guard and to ground and to power supply center top
Possible thermoelectric output	All paired junctions are in stable temperature environment With excitation off, output is read with switches in the off position and gage positions (all reading should be zero) With excitation off, output of 506 Ω resistors is read (output should be zero)
Possible diode effect	Read outputs with zero excitation; then compare outputs with normal and reverse excitation
Excitation voltage or changes	Monitor excitation before and after gage measurements

EPOXY CREEP EVALUATION TEST DESIGN

Test Equipment

<u>Potential Problem</u>	<u>Solution</u>
Temperature Monitoring	<p>Each beam box is equipped with a platinum resistor calibrated to an accuracy of 0.005°F.</p> <p>Each beam box is equipped with 2 copper constantan thermocouples which are continuously monitored with a 24-channel strip chart recorder. These sensors are used to monitor oven failures and are accurate to $\pm 2^{\circ}\text{F}$.</p> <p>Copper constantan thermocouples are used to monitor room, meters and power supply temperatures.</p> <p>Bulb thermometers are used to monitor standard cells and resistors temperature.</p>
Power Supplies	<p>Constant voltage is supplied by a KEPCO 0-2 VDC P.S. which is kept in an insulated oven.</p> <p>Constant current is supplied by a CALEX MMD 930/MK 296 current supply which is kept in an insulated oven.</p>
Digital Volt Meter, Fluke 8800A DVM	<p>Excitation voltage measurements are made on the 0.2 VDC scale with an accuracy of $\pm 54\mu\text{V}$ at 1 V excitation. Accuracy increases to $\pm 20\mu\text{V}$ at 1 V excitation when special daily transfer calibrations are made.</p> <p>Excitation current measurements are made across a precision $506 \pm 0.005\Omega$ resistor with an accuracy of $\pm 0.00011\text{ mA}$. The accuracy increased to $\pm 0.00005\text{ mA}$ when special transfer calibrations are made.</p> <p>Wheatstone bridge output measurements are made on the 200 mV DC scale with an accuracy of $\pm 5\mu\text{ V}$ at the 0-10 mV output range. With special transfer calibration the accuracy increases to $\pm 2\mu\text{ V}$ throughout the measuring range.</p> <p>Resistance measurements of the platinum temperature sensors are made on the 0 to 200Ω scale with an accuracy of $\pm 0.011\Omega$. The accuracy increases to $\pm 0.005\Omega$ with special transfer calibrations.</p>

Calibrations Standards
used for transfer
calibrations

Leeds and Northrup Model K-3 potentiometer
with an accuracy of $\pm 1\mu\text{V}$ throughout the
0 to 200 mV range.

Unsaturated standard cells nominally 1 V DC
with an accuracy of $\pm 10\mu\text{V}$ (2 cells)

Nominal 100 standard resistor with accuracy
 $\pm 0.001\Omega$, direct traceability to N.B.S.

Platinum Resistors

When used with the Fluke 8800 temperature can
be read with a resolution of $\pm 0.005^\circ\text{F}$ and
accuracy of $\pm 0.05^\circ\text{F}$ with transfer calibrations
accuracy increased to $\pm 0.02^\circ\text{F}$.

Precision Ice Bath

Maintain freezing point reference for measuring
changes in platinum resistor calibration.

APPENDIX L

EPOXY CREEP EVALUATION TEST UNCERTAINTY ANALYSIS

CONTENTS

Item	Page
Semiconductor Gage Evaluation	L-515
Epoxy Creep Evaluation Flow Chart	L-518
Foil Gage Evaluation	L-519
Problem Shooting	L-520
Cantilevered Beam Strain Analysis	L-523
Cantilevered Beam Strain Error Analysis	L-524
Summary	L-527

ILLUSTRATIONS

Figure	Page
L-257 Constant Moment Beam Dimensions	L-517
L-258 Epoxy Creep Evaluation-Beam Stability Test	L-518

EPOXY CREEP EVALUATION TEST UNCERTAINTY ANALYSIS

SEMICONDUCTOR GAGE EVALUATION

PURPOSE Determine the magnitude of epoxy creep of Epoxylite 6203 adhesives. Determine gage-factor-temperature sensitivity and aging of semiconductor strain gages.

METHOD Conduct both short and long term testing to evaluate epoxy creep, F_c , define as:

$$F_c = 4 \frac{E_o}{E_{ex}} \frac{1}{\epsilon_b} \frac{1}{GF}$$

Where:

E_{ex} = Bridge excitation voltage

E_o = Bridge output

ϵ_b = Beam strain

GF = Gage factor

F_c is more precisely written as:

$$F_c = 4 \frac{(E_o + \Delta E_o(E_o))}{(E_{ex} + \Delta E_{ex}(E_{ex}))} \left(\epsilon_{bo} + \frac{\partial \epsilon}{\partial T} \Delta T + \frac{\partial \epsilon}{\partial P} \Delta P + \frac{\partial \epsilon}{\partial g} \Delta g + \frac{\partial \epsilon}{\partial \alpha} \Delta \alpha \right) \left(GF_o + \frac{\partial GF}{\partial T} \Delta T + \frac{\partial GF}{\partial Age} \Delta Age \right)^{-1} \Delta F_c$$

Where:

E_o = Measure bridge output due to loading

$\Delta E_o(E_o)$ = Calibration correction for E_o , determined by transfer calibrations

E_{ex} = Measured bridge excitation

$\Delta E_{ex}(E_{ex})$ = Calibration correction for E_{ex} , determined by transfer calibrations

ϵ_{bo} = Calculated beam strain

$\frac{\partial \epsilon_b}{\partial T} \Delta T$ = Beam Strain Correction for small temperature variations

$\frac{\partial \epsilon_b}{\partial P} \Delta P$ = Beam Strain Correction for small pressure variations

$\frac{\partial \epsilon_b}{\partial g} \Delta g$ = Beam Strain Correction for small gravity variations

$\frac{\partial \epsilon_b}{\partial \alpha} \Delta \alpha$ = Beam Strain Correction for small in beam inclination angle variations

GF = Experimentally determined gage factor, normalizes $F_c = 1.0$ at outset of experiment.

$\frac{\partial GF}{\partial T} \Delta T$ = Gage factor correction due to small temperature variations, experimentally determined.

$\frac{\partial GF}{\partial \text{age}} \Delta \text{age}$ = Gage factor correction due to gage aging, experimentally determined

δF_c = Error in determining epoxy creep

also,

$$\left(\frac{\delta F_c}{F_c}\right)^2 = \left(\frac{\delta E_o}{E_o}\right)^2 + \left(\frac{\delta E_{ex}}{E_{ex}}\right)^2 + \left(\frac{\delta GF}{GF}\right)^2 + \left(\frac{\delta \epsilon_b}{\epsilon_b}\right)^2$$

due to accuracy limitations or uncertainties.

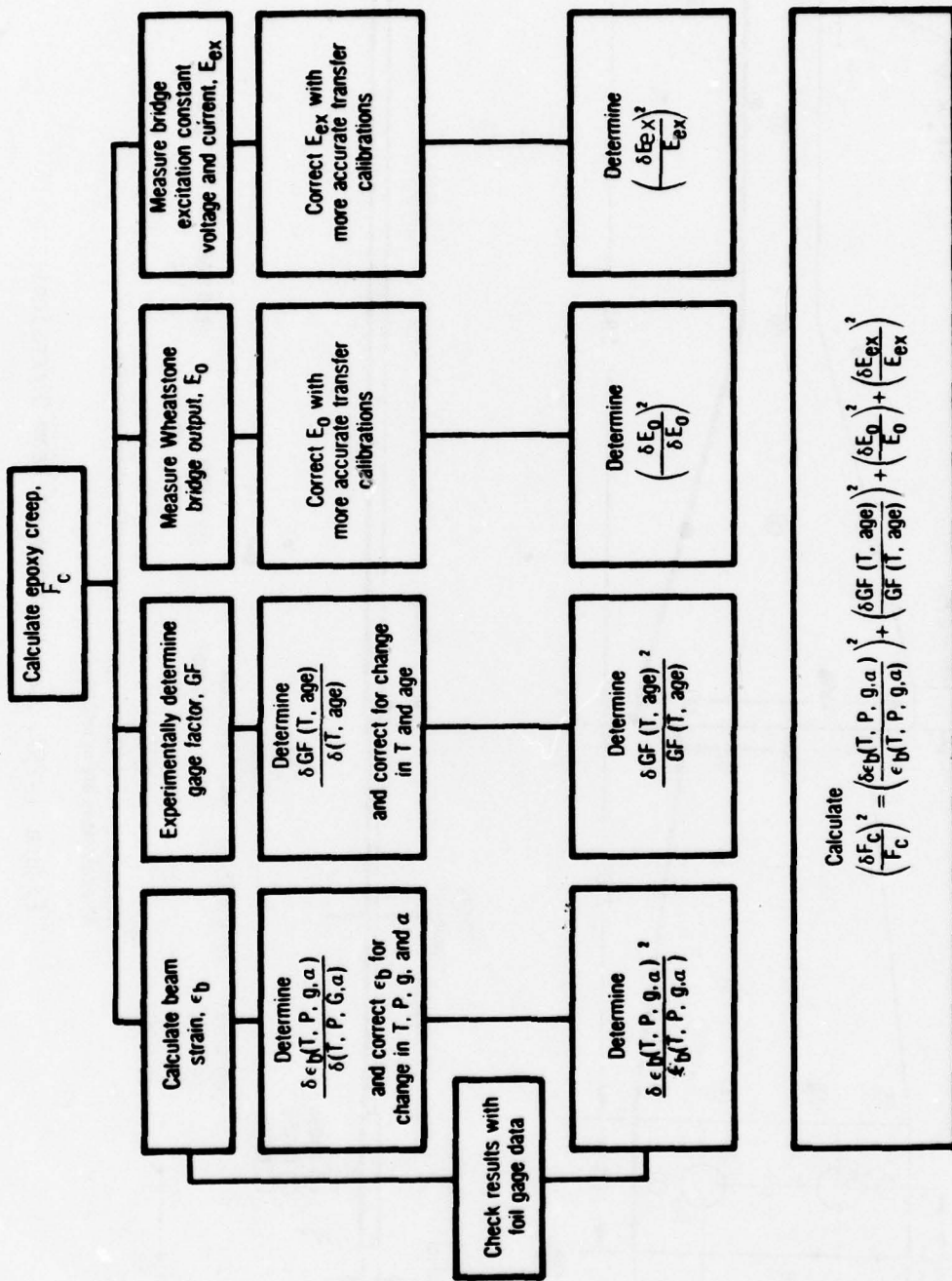

L-518

Figure L-258. Epoxy Creep Evaluation-Beam Stability Test

EPOXY CREEP EVALUATION TEST DESIGN

FOIL GAGE EVALUATION

PURPOSE Foil gage data is used to approximate beam strain variation during testing.

$$\epsilon_b = \frac{4}{GF} \left(\frac{E_0}{E_{ex}} - \frac{E_0'}{E_{ex}'} \right) \pm \delta\epsilon_b$$

where: ϵ_b = Δ beam strain of before & after beam loading
 GF = Foil gage factor
 E_0 = Gage output without added load
 E_{ex} = Constant voltage excitation to produce E_0 .
 E_0' = Gage output with added load
 E_{ex}' = Constant voltage excitation to produce E_0'
 $\delta\epsilon_b$ = Error in calculating beam strain via foil gage method.

$$\text{Also, } \delta\epsilon_b = \epsilon_b \sqrt{\left(\frac{\delta GF}{GF}\right)^2 + \left(\frac{\delta E_0}{E_0}\right)^2 + \left(\frac{\delta E_{ex}}{E_{ex}}\right)^2} + \sqrt{\left(\frac{\delta GF}{GF}\right)^2 + \left(\frac{\delta E_0'}{E_0'}\right)^2 + \left(\frac{\delta E_{ex}'}{E_{ex}'}\right)^2}$$

The error $\delta\epsilon_b$ can be calculated if we use test data available. For example, with

$$GF = 2.075 \pm .010$$

$$E_0 = 2.359 \pm .002 \text{ m Volts}$$

$$E_{ex} = 1.01964 \pm .00002 \text{ Volts}$$

$$E_0' = 2.250 \pm .002 \text{ m Volts}$$

$$E_{ex}' = 1.01568 \pm .00002 \text{ Volts}$$

$$\text{Added Load} = 221 \text{ gms}$$

$$= 207.05\mu\epsilon \pm 1.43\mu\epsilon \text{ STRAIN DUE TO ADDED LOADING}$$

EPOXY CREEP EVALUATION TEST DESIGN

Test Configuration

PROBLEM

1. Beam stress changes with constant load.
2. Temperature variations and gradients
3. Potential moisture problem
4. Vibrational Problems

SOLUTION

- A. Monitor end displacement of beam.
- A. Control oven heaters with proportional controllers, $\pm 0.5^{\circ}\text{F}$.
- B. Enclose beam in separate insulated box.
- C. Allow oven fan to operate continuously during conditioning.
- D. Monitor temperature variations to $\pm 0.005^{\circ}\text{F}$ with platinum resistors.
- A. Purge inner beam box with GN_2 .
Turn off GN_2 at least 2 hours before taking data.
- B. Monitor moisture with humidity gage.
- A. Isolate ovens from equipment with moving parts during data acquisition.

CANTILEVERED BEAM STRAIN ANALYSIS

A SOLUTION OF BEAM STRAIN CAN BE GIVEN AS:

$$\epsilon_b(T, P, g, \alpha) = \epsilon_{b_0} + \frac{\partial \epsilon_b}{\partial T} \Delta T + \frac{\partial \epsilon_b}{\partial P} \Delta P + \frac{\partial \epsilon_b}{\partial g} \Delta g + \frac{\partial \epsilon_b}{\partial \alpha} \Delta \alpha \pm \delta \epsilon_b \quad (1)$$

WHERE:

ϵ_b - BEAM STRAIN

ϵ_{b_0} - INITIAL BEAM STRAIN FOR A PARTICULAR GEOMETRY & BEAM MODULUS

T - BEAM TEMPERATURE

ΔT - DIFFERENCE BETWEEN INITIAL T AND T AT TESTING

P - OVEN BAROMETRIC PRESSURE

ΔP - DIFFERENCE BETWEEN INITIAL P AND P AT TESTING

g - MAGNITUDE OF GRAVITATIONAL FORCE

Δg - DIFFERENCE BETWEEN INITIAL g AND g AT TESTING

α - INCLINATION OF THE BEAM WITH THE HORIZONTAL

$\Delta \alpha$ - DIFFERENCE BETWEEN INITIAL α AND α AT TESTING

$\delta \epsilon_b$ - PROBABLE ERROR IN THE MEASURED STRAIN

CANTILEVERED BEAM STRAIN ANALYSIS

THE DIFFERENTIALS IN EQUATION (1) CAN BE SOLVED BY USING NOMINAL VALUES FOR GEOMETRY, MODULUS, PRESSURE, TEMPERATURE, GRAVITY AND INCLINATION ANGLE, THEN BY VARYING ONE INDEPENDENT VARIABLE AT A TIME IN EQUATION (2).

$$\epsilon_{b_0} = \frac{6 \left[\rho_m - \left(\frac{P}{RST} \right) \right] V_m \cos \alpha \left[\frac{1 + 4g}{g} \right] \left[\frac{\sum X_i W_i}{\sum W_i} \right] \left[c_{tm}(T - 70^\circ F) \right]}{b h^2 E} \quad (2)$$

where: ϵ_{b_0} = INITIAL BEAM STRAIN FOR A PARTICULAR GEOMETRY, MODULUS, TEMPERATURE, PRESSURE, GRAVITATIONAL FORCE AND INCLINATION ANGLE.

ρ_m = METAL DENSITY

P = BAROMETRIC PRESSURE

R_s = SPECIFIC GAS CONSTANT

T = TEMPERATURE IN OVEN

V_m = VOLUME OF METAL BEAM AND WEIGHT

α = INCLINATION ANGLE

g = NOMINAL GRAVITY

Δg = DIFFERENCE FROM NOMINAL GRAVITY

X_i = THE MOMENT ARM FROM THE FIXED END OF THE BEAM TO THE CENTER OF GRAVITY OF THE ITH SECTION OF THE BEAM

W_i = THE WEIGHT OF THE ITH SECTION

c_{tm} = COEFFICIENT OF LINEAR EXPANSION OF THE BEAM

CANTILEVERED BEAM STRAIN ANALYSIS

USING EQUATION (2) THE DIFFERENTIALS IN EQUATION (1) CAN BE CALCULATED. THE FOLLOWING SOLUTIONS RESULT:

$$1. \quad \frac{\partial \epsilon_{b\alpha}}{\partial T} = \left(3.2314 \times 10^{-4} \right) \frac{\mu\epsilon}{\sigma_F} \quad \text{CORRELATION COEFFICIENT} = .9999$$

$$2. \quad \frac{\partial \epsilon_{b\alpha}}{\partial p} = \left(-5.00 \times 10^{-4} \right) \frac{\mu\epsilon}{(\text{inch H.G.})} \quad \text{CORRELATION COEFFICIENT} = .9803$$

$$3. \quad \frac{\partial \epsilon_{b\alpha}}{\partial g} = \left(5.086 \times 10^{-2} \right) \frac{\mu\epsilon}{\text{milligal}} \quad \text{CORRELATION COEFFICIENT} = .9984$$

$$4. \quad \frac{\partial \epsilon_{b\alpha}}{\partial \alpha} = \left(\epsilon_{b\alpha} \right) (\sin \alpha) \quad \text{CORRELATION COEFFICIENT} = 1.0000$$

CANTILEVERED BEAM STRAIN ERROR ANALYSIS

THE PROBABLE ERROR IN THE BEAM STRAIN IS:

$$\left(\frac{\delta \epsilon_b}{\epsilon_b}\right)^2 = \left(\left(\frac{P/RsT}{\rho_m - (P/RsT)}\right)\left(\left[\frac{\delta P}{P}\right]^2 + \left[\frac{\delta T}{T}\right]^2\right)\right)^2 + \left(\frac{\delta V_m}{V_m}\right)^2 + \left(\frac{\delta \bar{X}}{\bar{X}}\right)^2 + (\tan \alpha \delta \alpha)^2 + \frac{\delta (\Delta g)}{\Delta g} + \frac{\delta b}{b} + 2 \frac{\delta h}{h}$$

WHERE: $\left(\frac{\delta P}{P}\right)$ = ERROR IN BAROMETRIC PRESSURE

$\left(\frac{\delta T}{T}\right)$ = ERROR IN BEAM TEMPERATURE

$\left(\frac{\delta V_m}{V_m}\right)$ = ERROR IN BEAM VOLUME

$\left(\frac{\delta \bar{X}}{\bar{X}}\right)$ = ERROR IN COMPUTING THE MOMENT OF INERTIAL

$(\tan \alpha \delta \alpha)$ = ERROR IN THE BEAM INCLINATION ANGLE

$\left(\frac{\delta (\Delta g)}{\Delta g}\right)$ = ERROR IN GRAVITY CORRECTION

$\left(\frac{\delta b}{b}\right)^2$ = ERROR OF BEAM WIDTH AT GAGE LOCATION

$\left(\frac{\delta h}{h}\right)^2$ = ERROR OF BEAM HEIGHT AT GAGE LOCATION

CANTILEVERED BEAM STRAIN ERROR ANALYSIS

THE ERRORS ARE ESTIMATED BY USING NOMINAL VALUES AND MEASUREMENT ACCURACY. THE RESULTS ARE SHOWN BELOW.

NOMINAL PRESSURE IS 30.00 INCH Hg ; MEASUREMENT ACCURACY IS .01 INCH Hg ; $\frac{\delta P}{P} = 3 \times 10^{-4}$

NOMINAL TEMPERATURE IS 530°R ; MEASUREMENT ACCURACY IS .005°R ; $\frac{\delta T}{T} = 9.4 \times 10^{-6}$

NOMINAL MOMENT OF INERTIAL IS 4.048 IN. ; MEASUREMENT ACCURACY IS .005 IN. ; $\frac{\delta \bar{X}}{\bar{X}} = 5.5 \times 10^{-4}$

NOMINAL INCLINATION ANGLE IS 2° ; MEASUREMENT ACCURACY IS 1° ; $\tan \alpha \delta \alpha = 6.10 \times 10^{-4}$

NOMINAL GRAVITY FORCE IS 979.850 GALS ; ACCURACY OF TABLE USAGE IS .020 GALS ; $\frac{\delta g}{g} = 2 \times 10^{-5}$

NOMINAL VOLUME IS 1.0737 IN³ ; MEASUREMENT ACCURACY IS .00241 IN³ ; $\frac{\delta V_m}{V_m} = 2.2 \times 10^{-3}$

NOMINAL HEIGHT IS .0500 IN. ; MEASUREMENT ACCURACY IS .0002 IN³ ; $\frac{\delta h}{h} = 4.0 \times 10^{-3}$

NOMINAL WEIGHT IS 2.000 IN. ; MEASUREMENT ACCURACY IS .001 IN ; $\frac{\delta w}{w} = 5 \times 10^{-4}$

$\frac{\delta \epsilon_b}{\epsilon_b} = .0024$
--

FACTORS CONCERNING BEAM STRAIN

1. PHYSICAL DIMENSION ARE HELD CONSTANT
2. CHANGES IN TEMPERATURE, BAROMETRIC PRESSURE, AND GRAVITATIONAL FORCE HAVE A NEGLIGIBLE EFFECT ON BEAM STRAIN; BUT THE STRAIN GAGE TEMPERATURE SENSITIVITY CAUSES THE TEMPERATURE UNCERTAINTY TO BE THE LARGEST FACTOR

$$\text{TEMPERATURE } \frac{\partial \epsilon_{b_0}}{\partial T} = 3.2314 \times 10^{-4} \frac{\mu\epsilon}{\text{O F}} \quad (\pm 5^\circ \text{ max.})$$

$$\text{PRESSURE } \frac{\partial \epsilon_{b_0}}{\partial P} = -5.00 \times 10^{-4} \frac{\mu\epsilon}{\text{inch Hg}} \quad (\pm 2 \text{ in. Hg max.})$$

GRAVITATIONAL FORCE

$$\frac{\partial \epsilon_{b_0}}{\partial (g)} = 5.086 \times 10^{-2} \frac{\mu\epsilon}{\text{gal}} \quad (\pm .120 \text{ gals. max.})$$

3. BEAM INCLINATION, α , PRODUCES THE 2D LARGEST UNCERTAINTY

4. THE BEAM STRAIN IS NOT EXTREMELY SENSITIVE TO THE APPLIED LOAD BEING $\frac{.812114 \mu\epsilon}{\text{gm}} = \frac{\partial \epsilon_{b_0}}{\partial \text{load}}$

5. THE UNCERTAINTY IN BEAM STRAIN DUE TO ACCURACY LIMITS OF TEMPERATURE, BAROMETRIC PRESSURE AND GRAVITATIONAL FORCE IS

$$\left(\frac{\delta \epsilon_{b_0} (T, P, g)}{\epsilon_{b_0} (T, P, g)} \right) = 2.04 \times 10^{-5}$$

EXAMPLE
AT BEAM STRAIN LEVEL
EQUAL TO 250 $\mu\epsilon$
 $\delta \epsilon_{b_0} = 5.1 \times 10^{-3} \mu\epsilon$

UNCERTAINTY SUMMARY

The largest source of measurement error is produced by the limiting accuracy of the temperature sensor-readout system. This error is estimated to be .11%

The second largest source of error is the uncertainty in beam inclination angle. With a sensitivity of $4.45\mu\text{e}/^\circ$, the uncertainty is estimated to be $.036^\circ$, leading to a measurement uncertainty of .06%

The third largest source of error is measuring the bridge output, estimated to be .02%.

All other measurement uncertainties are at least 2 orders of magnitude less.

APPENDIX M

GENERAL UNCERTAINTY ANALYSIS

By Dr. Robert Moffett

M-529

PRECEDING PAGE BLANK - NOT FILMED

Uncertainty Analysis

Measuring operations other than counting, which is inherently an integer operation, produce approximate values due to "uncertainty" in the last recorded digit (or perhaps the first un-recorded digit). When these approximate values are processed thru a data reduction program the uncertainties in the inputs produce an uncertainty in the output determined not only by the amount of uncertainty in the input values but also by the type of operations involved in the calculations. Some operations amplify the uncertainties, others tend to suppress them. The mathematical process of predicting the uncertainty in the output of a set of calculations is called "Uncertainty Analysis". The result of such an analysis is a rigorously derivable value, once the form of the equations is set and the uncertainties in the input values chosen. The judgmental aspects of Uncertainty Analysis are over once the uncertainty intervals have been assigned to the input variables. The term "Experimental Uncertainty" used in this sense is much more precise than is frequently implied (one often finds that any scatter in data is described as Experimental Uncertainty). An accurate prediction of the uncertainty in an experimental result is a powerful diagnostic tool as well as a valuable aid in selecting optimum test programs as will be demonstrated in later sections.

The most troublesome aspects of uncertainty analysis are the judgmental ones: what to use for the uncertainties in the input values? This question cannot be answered until the end use of the analysis is known.

If the objective is to predict the "scatter" which will appear in repeated trials at the same nominal set-point, then the uncertainties in the input variables should be chosen to reflect only those aspects which are not "fixed" during the repeated trials. "Uncertainty" in the calibrations of the instruments should not appear, because that aspect of the system would remain invariant during the repeated trials. The results would be wrong, if the

calibrations were wrong, but they would not "scatter" as long as the same instruments were used for each trial.

The objective of the analysis might, on the other hand, be to predict the agreement which could be expected if results from one set of experiments were compared with results of another in a different laboratory using a similar apparatus and similar instruments. In such a case the "uncertainty" in the instrument calibrations should be included since, with respect to the other apparatus, your data could "scatter" due to differences in the calibrations of the instruments. Discussion of this problem can be facilitated by introducing the notion of "replication level" and discussing the calculated result from an experiment as a function of several variables (the input measurements) and several parameters (the fixed aspects of the experiment). First, however, the description of "Uncertainty" must be quantified.

Describing the Uncertainty in a Value

When an instrument has an "analogue" output (an output which is not "digital" is "analogue") then human judgment is ultimately required to establish the reading. The interpolation operation, or estimation of the position of the pointer between two adjacent scale marks introduces an "uncertainty" into the reading. If an infinite number of independent readings were simultaneously obtained (to avoid any possible change with time) they would show a smooth distribution about their mean value. For many instruments the distribution is very nearly Gaussian or Normal so that approximately 95% of the data points lie within $\pm 2\sigma$ of the mean value, where σ is the standard deviation of the distribution (Ref. 1). Consider

H. D. Young, "Statistical Treatment of Experimental Data"
(McGraw-Hill Book Co., 1962) p. 64.

one additional reading of that same instrument: without even looking at its value, one might offer 20:1 odds that it would lie

within $\pm 2\sigma$ of the previously established mean. If the point lies within 2σ of the mean, then the mean lies within 2σ of the point! Thus, given the value of σ and any single reading, one might offer 20:1 odds that an infinite number of repetitions would produce a mean value within $\pm 2\sigma$ of the single available value. This latter situation closely parallels an experimental situation. By experience and special tests one establishes an estimate of σ for a given instrument. Then, rather than recording an infinite number of independent observations and taking the average, one estimates the band width within which the true value probably lies: this band width is the "uncertainty" associated with the measurement. In the absence of any better knowledge it is usual to center the band width about the actual observed value. Thus if the recorded value were 90.1 and previous experience indicated a value of σ of 0.05, a complete statement of the observation would be the following:

$$R = \underbrace{90.1}_{\substack{\text{the} \\ \text{observed} \\ \text{value}}} \pm \underbrace{0.1}_{\substack{\text{the} \\ \text{uncertainty}}} \quad \underbrace{(20:1)}_{\substack{\text{the} \\ \text{confidence} \\ \text{level}}} \quad (1)$$

Related by the
statistical prop-
erties of the
instrument

Note, for a given instrument, that the tighter the band width, the looser the odds. That is, one might be willing to wager 20:1 that not more than 1 person in twenty would have read the same instrument differently by more than ± 0.1 , but only 10:1 odds that the agreement would be within ± 0.05 and "even money" on $\pm .01$.

It will prove mathematically convenient to establish a uniform confidence level (ODDS) for all the estimates associated

with a given experiment, and adjust the uncertainty intervals associated with the individual readings. It is mathematically simplest to propagate uncertainties when they are quoted at a uniform probability.

In all the following discussions it will be assumed that each input value is presented in the format shown in Eq. (1) and that it is desired to also express the result of the experiment in that same format and at the same odds as quoted for the input values.

Replication Level and the Assignment of Uncertainty

It is desirable, at this point, to defer the mathematics of uncertainty propagation for multi-variable problems and symbolically discuss the results and their interpretation. The significant mathematics can be treated in later sections.

Let us discuss a result, R , calculated from a set of independent measurements, the x_i , and possibly affected by various other aspects of the experiment such as instrument calibrations, test procedures, or hardware design. Denote these other aspects of the experiment as parameters, the p_j , from their mathematical analogue. Thus the formal representation would be:

$$R = \mathcal{R}(x_1, x_2, x_3 \cdots x_n ; p_1, p_2, p_3 \cdots p_m) \quad (2)$$

the
calculated
result

Variables
Independently re-
corded for each trial
at the considered rep-
lication level

Parameters
Aspects of the experi-
ment which do not change
from trial to trial at
the considered replica-
tion level

The computing equation, \mathcal{R} , is the data reduction program. The values of the x_i are the inputs required. The result, R ,

is the numerical value of the output. The parameters do not explicitly appear: their effect is "behind the scenes" as, for example, the calibration of an instrument whose reading is used "as is".

Assume now that the uncertainty intervals for each of the variables have been selected to include only the interpolation uncertainties implicit in reading the instruments. These uncertainties can be formally propagated through the data reduction equations and will produce a value, δR_0 , which is the lower bound for the value of the uncertainty in the result R.

$$\delta R_0 = \delta R(\delta x_1, \delta x_2, \delta x_3 \dots \delta x_n). \quad (3)$$

This will be referred to as the uncertainty of the Zeroth Order Replication. No sequence of trials (repetitions of the experiment) can be expected to produce data with scatter less than the predicted value of δR_0 even if all the instrument readings are invariant with time. The uncertainty interval calculated for the Zeroth Order Replication is chiefly useful in predicting the effect of the individual instruments on the overall uncertainty of the experiment. In any experiment certain instruments are more critical than others and this can clearly be shown by an uncertainty analysis of the Zeroth Order.

Most physical experiments are not stationary but are subject to time-wise fluctuations, to one degree or another, and all sequences in the real world are necessarily time-wise. Thus "time" is an unrecorded variable in all sequences of trials and its effects are necessarily included in every real sequence of data. Let us re-evaluate the uncertainties in the x_i to include the time-wise random variations of the pointers of the instruments. Such an evaluation is easily conducted: one simply sets the test apparatus to a particular set point and then records 21 independent readings from each instrument. The resulting scatter provides an

estimate of the uncertainty interval for 20:1 odds (one reading of the twenty-one lies outside the interval). Formally this operation is equivalent to including time, θ , as an independent variable and evaluating its effect on each of the independent variables as an expansion in a time series. The effect is that one more variable has been added to the input string: the resulting uncertainty will be denoted by δR_1 , the uncertainty for the First Order Replication.

$$\delta R_1 = \delta R(\overline{\delta x_1}, \overline{\delta x_2}, \overline{\delta x_3} \cdots \overline{\delta x_n}) \quad (4)$$

The $\overline{\delta x_i}$ include the average effect of time-wise fluctuations

The Uncertainty for a First Order Replication is the lowest value which can be expected for the scatter in a sequence of trials using all the same instruments and equipment. It follows that δR_1 must be equal to or greater than δR_0 , and is only equal to δR_0 under the rare conditions when all readings are stationary.

The value δR_1 provides the first diagnostic utility of uncertainty analysis. If the values from a sequence of trials at the First Order Replication level (i.e. all the same instruments and equipment) show a larger "scatter band" than the anticipated value of $\pm \delta R_1$, then the data reduction program used in calculating the result, R , from the inputs, x_i , does not include all of the aspects of the experiment which are, in fact, variable during the sequence. This can be represented formally by the claim that one or more of those aspects listed as parameters (i.e. invariant during the sequence of trials) are in fact variables and their effects should be included in the data reduction program.

To illustrate this point let us consider an experiment aimed at determining the heat transfer Stanton number, h/Gcp , for a boundary layer flow along a flat plate. A sequence of trials on different days might yield results varying by $\pm 1\%$ due to day-by-day variations in the humidity of the air (the specific heat of water vapor is twice that of dry air!). An otherwise carefully controlled experiment which, in its data reduction program, assumed the specific heat to be a constant would produce values of the Stanton number which reflected the variations in specific heat. If the anticipated scatter band for a First Order Replications of that experiment were sufficiently narrow, then the additional 1% scatter due to the unrecognized variable (humidity) would be visible: the actual data would scatter 1% more than expected. This occurrence should suggest to the cautious experimenter that his experiment was not yet adequately described by his data reduction program.

The First Order Replication level is thus related to repeated trials on the same apparatus, using the same instruments. Uncertainty intervals calculated for this replication level are useful in developing an experiment and its data reduction program. For such a level the intervals for the inputs should include not only the instrument interpolation interval but also the effects of time-wise variations in a nominally steady reading.

For every recorded bit of input data there is at least one instrument and each instrument is a member of a family of instruments whose calibrations are randomly distributed. Assume, now, that one of the instruments is replaced by another of the same design but different identity and a second sequence of trials recorded. The mean value from the second sequence will differ from that of the first if the calibration of the new instrument differs from the old. All such possible exchanges can be accommodated in the uncertainty analysis by including the instrument calibration uncertainties into the values chosen for the $\overline{\sigma_{x_1}}$. This implies replication of a very high order which will be referred to as the N^{th} Order Replication

$$\delta R_N = \delta R(\overline{\delta x_1}, \overline{\delta x_2}, \overline{\delta x_3} \dots \overline{\delta x_n}) \quad (5)$$

the $\overline{\delta x_i}$ include instrument calibration uncertainties

Results from any one experimental program should show much less scatter than that predicted by the N^{th} Order Replication, and results from any group of experimental studies (different pieces of apparatus etc.) should agree with one another to within the predicted values of δR_N providing that the physical structure of the apparatus used in each experiment is the same.

The N^{th} Order Replication level is the level of uncertainty at which one must present his data for comparison with the work of other investigators. Note that the process of calibrating an instrument is one of eliminating the uncertainty as to its identity and substituting the uncertainty regarding the identity of the reference instrument (hopefully a smaller value). Thus a dime-store thermometer with an uncertainty interval of $\pm 2^{\circ}\text{F}$ could be equipped with a magnifying scale reader, a scale vernier, and calibrated against a reference thermometer to $\pm 0.01^{\circ}\text{F}$ and, providing it were stable and repeatable, this calibration is now "uncertain" only to that level ($\pm 0.01^{\circ}\text{F}$). A calibration equation is an extension of the data reduction program aimed at reducing the uncertainty.

There is an alternative way of discussing the different replication levels which may be useful. Consider a result, R , derived from a set of input data, the x_i , subject to change with time θ , and to certain parameters, the p_j , of which the first "n" are instrument calibrations. The different replication levels can be thought of as the result of shifting the separation point between variables and parameters.

$$R = R(x_1, x_2, x_3 \cdots x_n; \theta, p_1, p_2, p_3 \cdots p_n, p_{n+1} \cdots p_m)$$

measured
variables

time

instrument
calibrations

stationary
factors

The Zeroth Order Replication fixes time and all parameters:

$$\delta R_0 = \delta R(\delta x_1, \delta x_2, \delta x_3 \cdots \delta x_n) \quad (7)$$

The First Order Replication Level permits time to vary and includes the uncertainties due to non steady behavior.

$$\delta R_1 = \delta R(\overline{\delta x_1}, \overline{\delta x_2}, \overline{\delta x_3} \cdots \overline{\delta x_n}, \overline{\delta \theta}) \quad (8)$$

The Nth Order Replication permits time to vary, includes the uncertainties due to non-steady behavior, and considers instrument identity as a possible random variable.

$$\delta R_N = \delta R(\overline{\delta x_1}, \overline{\delta x_2}, \overline{\delta x_3} \cdots \overline{\delta x_n}, \overline{\delta \theta}, \delta p_1, \delta p_2, \delta p_3 \cdots \delta p_n) \quad (9)$$

It is clear that even the uncertainty predicted at the Nth Order Replication Level cannot anticipate variations due to the physical structure of the apparatus or to differences in the general experimental approach chosen. It remains the responsibility of the investigator to ensure that the physical structure of the apparatus does not affect the quoted results. One brief example: suppose that an experiment is proposed to measure the velocity distribution in a pipe of diameter D by traversing a probe of diameter d across it. The relative size d/D will affect the blockage at any position of the probe. Probes of different diameters will cause different values of tunnel blockage and will

yield different profiles of velocity. These differences are not amenable to uncertainty analysis. If, however, the data reduction program is designed to correct for this blockage effect, then the uncertainty in the correction process can be incorporated into either the velocity or the position variable (assuming that the correction program has, on average, the correct effect).

If results from different experimental groups fail to agree to within the expected value of $\pm\delta R_N$ this suggests that there are structural effects in the experiments which have not yet been identified.

Propagation of Uncertainties in Multi-Variable Problems

When a result, R , is computed from several different inputs, each of which has an uncertainty described as in Eq. (1), then the value of the result is uncertain. If the uncertainties in the inputs are bounded then we could describe the greatest possible excursion in R which could occur due to the least favorable combination of the largest allowable excursions in each input. Such a measure of the uncertainty in R is sometimes useful, when the penalty for optimism is great and the price of pessimism is low. Such a large value is, however, the least likely value for the excursion in R : it requires that simultaneously each input is perturbed to its greatest extent. What is generally desired is a statement of the most probable value of the uncertainty interval in R , expressed at the same confidence level as was used in describing the inputs. Such a statement requires that the uncertainties in the inputs be propagated through the data reduction program at constant probability. It has been shown by Kline and McClintock (Ref. 2) that such a propagation can be

S. J. Kline and F. A. McClintock, "Describing Uncertainties in Single Sample Experiments", Mechanical Engineering, January 1953.

done in a relatively simple manner as described below.

Consider a result R , a function of several variables, the x_i , and write the formal expression for the change in R which would result from an infinitesimal change, dx_i , in each of its variables. Note that dR is the excursion which would result

$$dR = \frac{\partial R}{\partial x_1} dx_1 + \frac{\partial R}{\partial x_2} dx_2 + \cdots + \frac{\partial R}{\partial x_n} dx_n \quad (10)$$

if each of the x_i were simultaneously perturbed by an amount δx_i . Thus dR is related to the least probable but largest value of the possible effect of changes in the x_i (assuming all the coefficients positive, for convenience). In a system where the perturbation in the x_i are uncertainties and not specified perturbation, then some of the δx_i will probably be positive and some will probably be negative so that the net effect will not be as large as it might be. Kline and McClintock have shown that the way to combine the individual effects which most nearly preserves the true statistical probability is to use a Root-Sum-Square addition:

$$\delta R = \left\{ \left(\frac{\partial R}{\partial x_1} \delta x_1 \right)^2 + \left(\frac{\partial R}{\partial x_2} \delta x_2 \right)^2 + \cdots + \left(\frac{\partial R}{\partial x_n} \delta x_n \right)^2 \right\}^{1/2} \quad (11)$$

For such a combination:

- IF -
1. Each variable is independent and comes from a Gaussian distribution and,
 2. Each variable is described by a statement of the form

$$x_i = \bar{x}_i \pm \delta x_i \text{ at (ODDS)}$$

where the same odds are used for each of the variables.

THEN -

$$R = \bar{R} + \delta R \text{ at (ODDS)}$$

where δR is given by Eq. (11) and the odds are preserved.

In many situations the relative, or percentwise, uncertainty is of more significance than the absolute value. When the result, R , can be expressed as a product of several factors the relative uncertainty is very easy to derive, even when the factors are raised to different powers.

$$\text{IF: } R = (x_1^a)(x_2^b)(x_3^c) \dots$$

$$\text{Then } \frac{\partial R}{\partial x_1} = ax_1^{a-1}(x_2^b)(x_3^c) \dots = \frac{aR}{x_1}$$

$$\frac{\partial R}{\partial x_2} = (x_1^a)(bx_2^{b-1})(x_3^c) \dots = \frac{bR}{x_2}$$

⋮

yielding:

$$\frac{\delta R}{R} = \left\{ \frac{\frac{aR}{x_1} \delta x_1^2 + \frac{bR}{x_2} \delta x_2^2 + \dots}{R^2} \right\}^{1/2}$$

$$\frac{\delta R}{R} = \left\{ \frac{a\delta x_1^2}{x_1} + \frac{b\delta x_2^2}{x_2} + \dots \right\}^{1/2} \quad (12)$$

The form $\frac{\delta x_i}{x_i}$ represents the percentwise uncertainty in the value of x_i . Note that the exponent becomes the "weighting

factor" and that the sign of the exponent does not affect the result. Many instrument calibrations are expressed in "percent of reading" and fit very conveniently into this format. Note that instrument calibrations expressed as "percent of full scale reading" do not satisfy this criterion: that sort of specification describes the absolute, not the relative, uncertainty.

Table I: Examples

1. $R = \sum_{i=1}^N x_i$	1. $\delta R = \left\{ \sum_{i=1}^N (\delta x_i)^2 \right\}^{1/2}$
2. $R = \sum_{i=1}^N x_i$ with $\delta x_i = \delta x$	2. $\delta R = \sqrt{N} \delta x$
3. $R = \frac{1}{N} \sum_{i=1}^N x_i$ with $\delta x_i = \delta x$	3. $\delta R = \frac{1}{\sqrt{N}} \delta x$
4. $R = x_1^a + x_2^b + \dots$	4. $\delta R = \left\{ (ax_1^{a-1} \delta x_1)^2 + (bx_2^{b-1} \delta x_2)^2 + \dots \right\}^{1/2}$
5. $R = (x_1)^a (x_2)^b (x_3)^c \dots$	5. $\delta R = \left\{ \frac{a \delta x_1}{x_1}^2 + \frac{b \delta x_2}{x_2}^2 + \dots \right\}^{1/2}$
AND:	$\frac{\delta R}{R} = \left\{ \frac{a \delta x_1}{x_1}^2 + \frac{b \delta x_2}{x_2}^2 + \dots \right\}^{1/2}$

If the uncertainty interval for each of the inputs has been selected for the same odds, say 20:1, then Eqs. (11) and (12) predict the uncertainty in the result for those same odds. The same form is used for calculating the uncertainty for any replication level - only the values of the δx_i change.

Evaluating the Coefficients

When the experiment is such that R is given explicitly by an equation involving the x_i , the value of each coefficient is found by taking the partial derivative of R with respect to that variable ($\partial R/\partial x_i$) and evaluating that partial derivative at the conditions of the test. Some experiments involve sequences of calculations so involved that it is impractical to evaluate the partial derivatives analytically. If the data reduction operation has been programmed for computer use, then it is possible to numerically approximate ($\partial R/\partial x_i$) using the definition of partial derivative:

$$\frac{\partial R}{\partial x_i} \triangleq \lim_{\Delta x_i \rightarrow 0} \frac{R(x_i + \Delta x_i) - R(x_i)}{\Delta x_i} \quad (13)$$

(all other
variables
held constant)

To execute this, one would first reduce the data with the given input values of each of the x_i , store the value R , and then recompute R increasing one of the input values by a small amount. This re-computation is required once for each variable. The result is a set of numerically deduced approximations to the values of ($\partial R/\partial x_i$) which can be used in Eq. (11) to evaluate the uncertainty.

Data reduction programs involving judgment such as graphical differentiation or curve matching, pose special problems. Experience suggests that the uncertainties in these operations should be treated as separate inputs, with independent uncertainty intervals deduced by repeated trials, rather than attempting to deduce them based on the coordinates of the input points.

The Root-Sum-Square combination has the effect of strongly emphasizing the larger terms and suppressing the smaller. Consider, for example, the following strings:

$$5 + 1 + 1 + 1 + 1 + 1 = 10$$

$$(25 + 1 + 1 + 1 + 1 + 1)^{1/2} = (30)^{1/2} = 5.49$$

Note that eliminating every one of the unity variables has the effect of reducing the Root-Sum-Square by only 10%. One can be reasonably safe in discarding any term less than one-fifth the size of the largest term. A common error in applying uncertainty analysis is to become involved in an endless un-raveling of the equations, introducing uncertainties in π and g_c and J ad-infinitum until the significance of the result is lost in the probability of numerical errors.

The Independence Criterion and Shared Variables

Long and complicated sets of calculations are tedious to handle by uncertainty analysis. It is frequently attractive to think of the final result, R , as being computed by a brief formula involving subordinate results, the R_i , each of which has been evaluated by a smaller, more tractable data reduction program. Rather than a single large equation for the uncertainty in the result, one deals, then, with a small set of simpler equations for the values of δR_i , and then one final equation for δR . Such a technique must, however, be used with caution. A fundamental assumption required to justify the Root-Sum-Square propagation is that each of the variables is independent. If any two of the subordinate results, the R_i , share a common input variable, then they are not independent in the sense required here. Treating them as independent has the effect of over emphasizing the uncertainty in the shared variable: its effect is counted twice.

Consider the uncertainty in a calculation of the effectiveness of a heat exchanger based on measurements of the temperatures of the fluid streams. For simple cases:

$$\xi = \frac{T_2 - T_1}{T_3 - T_1} \quad (14)$$

Assuming each temperature to be measured independently, then

$$\delta \xi = \left\{ \frac{\partial \xi}{\partial T_1} \delta T_1^2 + \frac{\partial \xi}{\partial T_2} \delta T_2^2 + \frac{\partial \xi}{\partial T_3} \delta T_3^2 \right\}^{1/2} \quad (15)$$

$$= \frac{1}{T_3 - T_1} \left\{ [(\xi - 1) \delta T_1]^2 + \delta T_2^2 + [\xi \delta T_3]^2 \right\}^{1/2} \quad (16)$$

$$\frac{\delta \xi}{\xi} = \frac{1}{T_3 - T_1} \left\{ \left(\frac{\xi - 1}{\xi} \delta T_1 \right)^2 + \left(\frac{1}{\xi} \delta T_2 \right)^2 + \delta T_3^2 \right\}^{1/2} \quad (17)$$

It might appear simpler to deal with the effectiveness as the quotient of two temperature differences, thus yielding only two terms in the uncertainty analysis:

$$\text{Let } \Delta T_{12} \stackrel{\Delta}{=} T_2 - T_1 \quad \text{and} \quad \Delta T_{13} \stackrel{\Delta}{=} T_3 - T_1$$

$$\text{Then } \xi = \frac{\Delta T_{12}}{\Delta T_{13}} \quad (18)$$

Given this form, one might propose that the "product" form applies. Let us examine this hypothesis.

$$\frac{\delta \xi}{\xi} \stackrel{?}{=} \left\{ \left(\frac{\delta \Delta T_{12}}{\Delta T_{12}} \right)^2 + \left(\frac{\delta \Delta T_{13}}{\Delta T_{13}} \right)^2 \right\}^{1/2} \quad (19)$$

$$\text{where } \delta \Delta T_{12} = \left\{ (\delta T_1)^2 + (\delta T_2)^2 \right\}^{1/2}$$

$$\delta \Delta T_{13} = \left\{ (\delta T_1)^2 + (\delta T_3)^2 \right\}^{1/2}$$

Equation (19) is certainly simpler than Eq. (17). It is not correct, however, since it treats T_1 as having been measured twice, once to evaluate the numerator and once to evaluate the denominator. Note that the experiment could have been instrumented to make Eq. (19) true, by installing two temperature sensors in location 1 and reading each independently of the other. Similarly, Eq. (19) could have been made correct by installing differential thermocouples to directly measure the two temperature differences. The form of the uncertainty analyses and the technique of the experiment are closely connected.

Let us proceed by expanding Eq. (19) and comparing the result with Eq. (17). From Eq. (19) we obtain

from (19)

$$\frac{\delta \xi}{\xi} \stackrel{?}{=} \frac{1}{T_3 - T_1} \left\{ \frac{1}{\xi^2} \delta T_1^2 + \delta T_1^2 + \frac{1}{\xi} \delta T_2^2 + \delta T_3^2 \right\}^{1/2}$$

$$\frac{\delta \xi}{\xi} \stackrel{?}{=} \frac{1}{T_3 - T_1} \left\{ \left(\frac{\xi - 1}{\xi} \delta T_1 \right)^2 + \frac{2}{\xi} (\delta T_1)^2 + \left(\frac{1}{\xi} \delta T_2 \right)^2 + \delta T_3^2 \right\}^{1/2} \quad (20)$$

from (17)

$$\frac{\delta \xi}{\xi} = \frac{1}{T_3 - T_1} \left\{ \left(\frac{\xi - 1}{\xi} \delta T_1 \right)^2 + \left(\frac{1}{\xi} \delta T_2 \right)^2 + \delta T_3^2 \right\}^{1/2}$$

Note that the result from Eq. (19) contains an extra term involving δT_1 , as a result of sharing that variable between the numerator and denominator. As a result of this extra term the calculated uncertainty in effectiveness will be too large. While this may seem, at first glance, to be "conservative" and therefore acceptable, it may not be. If the uncertainty analysis is being conducted with values of the δx_i chosen for a First Order Replication, with the objective of predicting the expected

scatter in a sequence of data, then this overly-large prediction of δR has the effect of relaxing the criterion for acceptance of the data. If the calculation is of N^{th} Order, aimed at comparing results from two different sets of experiments, then the use of an overly large uncertainty may hinder identification of real differences between the data sets. The problem of shared variables also arises in evaluating the uncertainty in integral parameters derived from experimental data. When a probe is traversed across a region there is an uncertainty in its position as well as its output, and each affects the uncertainty in the integral. Both the ordinate and the position value from each probe location are "shared" by the interval on either side.

Use of Uncertainty Analysis in Selecting the Optimum Experimental Technique

It frequently occurs that more than one experimental technique could be applied to a given problem. Uncertainty analysis can provide a rational basis for choosing among these alternates, before the experiment is run. Consider the heat exchanger problem illustrated by Eq. (17)

$$(17) \quad \frac{\delta \xi}{\xi} = \frac{1}{T_3 - T_1} \left\{ \left(\frac{\xi - 1}{\xi} \delta T_1 \right)^2 + \left(\frac{1}{\xi} \delta T_2 \right)^2 + \delta T_3^2 \right\}^{1/2}$$

Note that the result, ξ , occurs inside the expression for the fractional uncertainty. How then could one execute this analysis before ξ had been measured? The answer is: parametrically. Assume a set of values for ξ and solve Eq. (17) to show the way in which the uncertainty varies. To illustrate, let us compare the relative importance of errors in T_1 , T_2 and T_3 as the effectiveness changes.

Table II. Parametric Evaluation of $\delta\xi/\xi$

ξ	$\frac{\partial\xi}{\partial T_1}$	$\frac{\partial\xi}{\partial T_2}$	$\frac{\partial\xi}{\partial T_3}$
.1	9	10	1
.2	4	5	1
.4	1.5	2.5	1
.6	.66	1.66	1
.8	.25	1.25	1
1.0	0	1.0	1

Thus T_1 and T_2 are much more important than T_3 in setting the uncertainty in ξ at low values of ξ . All are about equally important at intermediate values ($\xi \approx 0.6$) and T_1 is of less and less importance as ξ approaches unity. Except in the case of the most pioneering sort of experiment, the result can usually be anticipated with at least "order of magnitude" accuracy. If, in this instance, ξ were expected to be low, then the measurements of T_1 and T_2 would have to be very carefully handled, and this can be determined from Table II without knowing exactly what value of ξ will result.

Table II illustrates the use of parametric uncertainty analysis to identify the critical measurements in an experiment. It is thus an aid to the efficient allocation of resources, once the experiment has been chosen. The same form of analysis can be used to choose between two candidate experimental techniques, each capable of producing the same output.

Consider the problem of measuring the average heat transfer coefficient from a 1.0-inch diameter, round rod 1-foot long (neglecting end effects). Two techniques have been proposed: steady state, and transient.

Steady State Test:

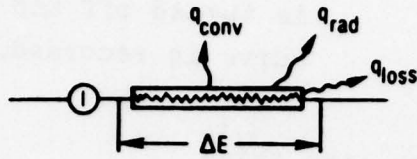

The rod is suspended in the stream and electrically heated. When steady state has been reached, the data are taken.

Figure M-259

17721

Data for Steady State Test

<u>Measurand</u>	<u>Units</u>	<u>Symbol</u>
POWER	Watts	W
TEMP. of ROD	°F	T
TEMP. of GAS	°F	T _G
DIA. of ROD	FT	D
LENGTH of ROD	FT	L

The heat transfer coefficient can be deduced from the following definition:

$$h \triangleq \frac{\dot{q}_o}{A(T-T_G)} = \frac{\text{POWER} - q_{\text{rad}} - q_{\text{loss}}}{A(T-T_G)} \quad (21)$$

For simplicity, we shall assume $q_{\text{rad}} = q_{\text{loss}} = 0$

$$h = \frac{0.000948 \text{ W}}{\pi DL(T-T_G)} \quad (22)$$

Transient technique

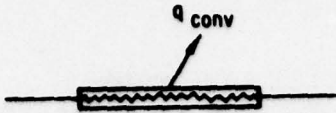

Figure M-260
(Assuming No Losses)

17722

The rod is suspended in the stream and electrically heated. When steady state has been reached, the power is turned off and the cooling curve is recorded.

The temperature-time record might look like this:

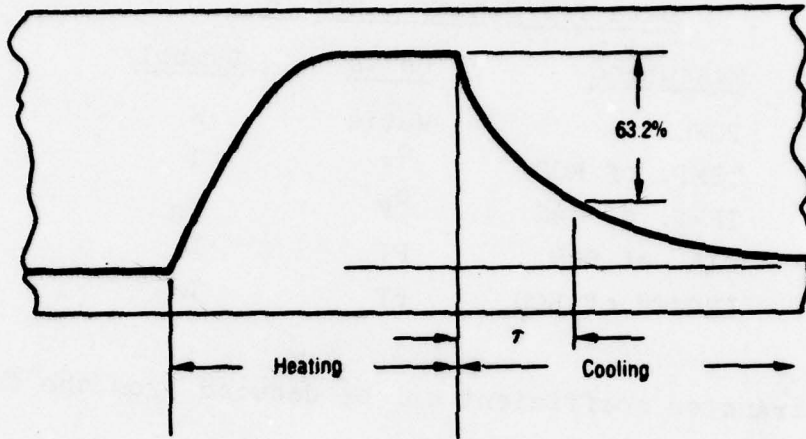

Figure M-261

17726

From the cooling curve, one can measure the time, in seconds, required for the rod to complete 63.2% of its response to this step change in conditions. This time is called the characteristic time, τ , and is related to the heat transfer coefficient and thermal storage capacity of the rod by the following:

$$\tau = \frac{Mc}{hA} \quad (23)$$

where M = mass of rod, lb_m

c = specific heat of rod material, $\text{Btu}/\text{lb}_m \text{ } ^\circ\text{F}$

h = heat transfer coefficient, $\text{Btu}/\text{sec ft}^2 \text{ } ^\circ\text{F}$

A = Area, ft^2

Data for Transient Test

<u>Measurand</u>	<u>Units</u>	<u>Symbol</u>
MASS of ROD	lb_m	M
SPECIFIC HEAT (ROD)	$\text{Btu}/\text{lb}_m \text{ } ^\circ\text{F}$	c
DIAMETER OF ROD	FT	D
LENGTH of ROD	FT	L
CHARACTERISTIC TIME	SEC	τ

Steady State Test: Uncertainty Analysis

$$h = \frac{0.000948 \text{ W}}{\pi DL(T-T_G)} \quad (24)$$

$$\frac{\delta h}{h} = \left\{ \frac{\delta W}{W}^2 + \frac{\delta D}{D}^2 + \frac{\delta L}{L}^2 + \frac{\delta \Delta T}{\Delta T}^2 \right\}^{1/2} \quad (25)$$

Experience dictates the following values of uncertainty for the instruments used in this test:

$$\delta W = 0.5 \text{ watts}$$

$$\delta D = 0.001 \text{ inches}$$

$$\delta L = 0.005 \text{ inches}$$

$$\delta T = 0.25 \text{ } ^\circ\text{F} \text{ (each temperature reading)}$$

In order to execute the uncertainty analysis before the experiment, it is necessary to estimate values for each measurand which is not

already known. Choose $\Delta T = 20^{\circ}\text{F}$ as a standard test condition. The heat transfer coefficient is estimated to lie between 0.001 and 1.0 Btu/sec ft², based on data from a similar system.

$$h = 0.001 \text{ yields } W = 5.52 \text{ watts}$$

$$h = 1.000 \text{ yields } W = 5520 \text{ watts}$$

The uncertainty analyses can be numerically executed.

$$\frac{\delta W}{W} = 0.091 \quad \text{at } h = 0.001$$

$$\frac{\delta W}{W} = 0.000091 \quad \text{at } h = 1.000$$

$$\frac{\delta D}{D} = 0.001$$

$$\frac{\delta L}{L} = 0.00041$$

$$\frac{\delta \Delta T}{\Delta T} = 2 \frac{\delta T}{\Delta T} = 0.0177$$

The uncertainty interval can now be estimated numerically.

For $h = 0.001$

$$\frac{\delta h}{h} = \left\{ (0.091)^2 + (0.001)^2 + (0.00041)^2 + (0.0177)^2 \right\}^{1/2} \quad (26)$$

$$\frac{\delta h}{h} = 0.0926 \quad (\text{Note that the dominant term is } \frac{\delta W}{W}) \quad (27)$$

For $h = 1.000$

$$\frac{\delta h}{h} = \left\{ (0.000091)^2 + (0.001)^2 + (0.00041)^2 + (0.0177)^2 \right\}^{1/2} \quad (28)$$

$$\frac{\delta h}{h} = 0.0177 \quad (\text{Note that the dominant term is } \frac{\delta \Delta T}{\Delta T}) \quad (29)$$

Thus the uncertainty in h changes (due to the variation of $\delta W/W$) as h changes. The estimated uncertainty of the steady state test is:

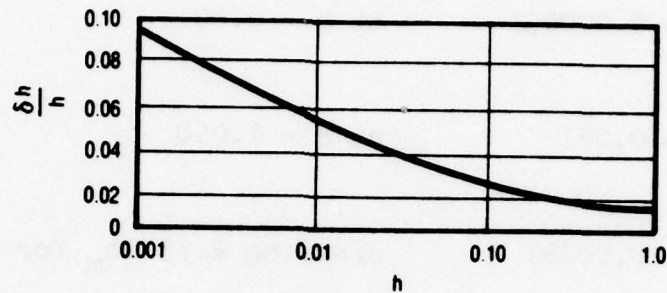

Figure M-262

17727

Transient Test: Uncertainty Analysis

$$h = \frac{Mc}{\tau A} \quad (30)$$

$$\frac{\delta h}{h} = \left\{ \frac{\delta M}{M}^2 + \frac{\delta c}{c}^2 + \frac{\delta \tau}{\tau}^2 + \frac{\delta D}{D}^2 + \frac{\delta L}{L}^2 \right\}^{1/2} \quad (31)$$

Experience with the recorder and other instruments to be used suggests the following unit uncertainties:

$$\delta M = 0.0022 \text{ lb}_m$$

$$\delta c = 0.001 \text{ Btu/lb}_m \text{ } ^\circ\text{F}$$

$$\delta D = 0.001 \text{ inches}$$

$$\delta L = 0.005 \text{ inches}$$

$$\delta \tau = 0.05 \text{ seconds (measured on chart)}$$

It is again necessary to estimate the values of τ which will be encountered.

when $h = 0.001$ $\tau = 980$ seconds
 $h = 1.000$ $\tau = .980$ seconds

The analyses can now be numerically executed.

$$\frac{\delta\tau}{\tau} = 0.000051 \quad \text{at } h = 0.001$$

$$\frac{\delta\tau}{\tau} = 0.051 \quad \text{at } h = 1.000$$

$$\frac{\delta M}{M} = 0.00081 \quad \text{assuming } 2.73 \text{ lb}_m \text{ for } M$$

$$\frac{\delta c}{c} = 0.011 \quad (\text{assuming } c = 0.0940)$$

$$\frac{\delta D}{D} = 0.001$$

$$\frac{\delta L}{L} = 0.0041$$

for $h = 0.001$:

$$\frac{\delta h}{h} = \left\{ (0.00081)^2 + (0.011)^2 + (0.000051)^2 + (0.001)^2 + (0.0041)^2 \right\}^{1/2} \quad (32)$$

$$\frac{\delta h}{h} = 0.012 \quad (\text{Note that the dominant term is } \frac{\delta c}{c}) \quad (33)$$

for $h = 1.000$

$$\frac{\delta h}{h} = \left\{ (0.0081)^2 + (0.011)^2 + (0.051)^2 + (0.001)^2 + (0.0041)^2 \right\}^{1/2} \quad (34)$$

$$\frac{\delta h}{h} = 0.052 \quad (\text{Note that the dominant term is } \frac{\delta \tau}{\tau}) \quad (35)$$

Again, the uncertainty interval changes as h changes.

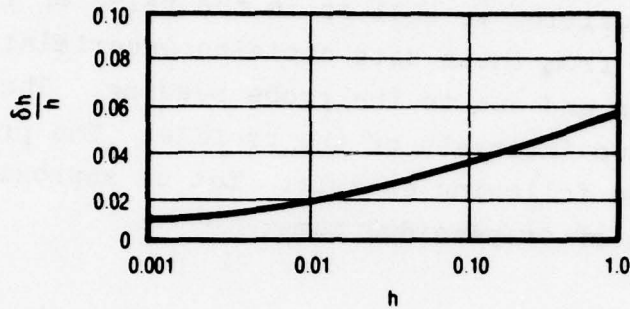

Figure M-263

17728

Comparison

Plotting both uncertainty curves on the same figure shows clearly the "break even" point.

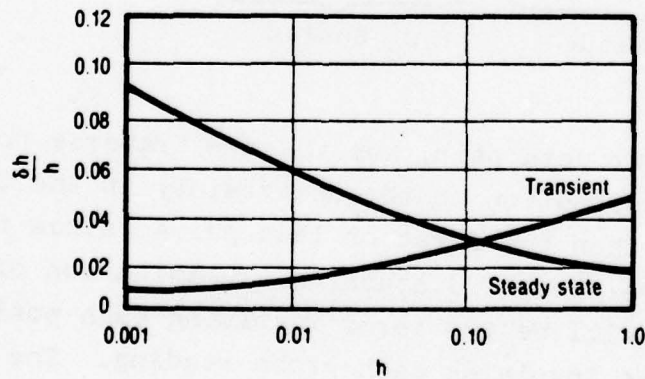

Figure M-264

17729

For conditions where $h \leq 0.11$, the steady state test introduces more uncertainty than does the transient test. At high heat transfer rates the steady state test offers better performance.

Integrals of Experimental Profile Data

When a probe is traversed across a region there is an uncertainty in its position as well as in the value of its output. The integral deduced from these data contains uncertainties due to the probe position and due to the probe reading. These values are each shared by two intervals of the profile. The problem can be illustrated by the following example. Let us approximate the integral by a series of trapezoidal sums:

$$R = \int_0^S p \, ds \approx \sum_{i=1}^N \left(\frac{p_i + p_{i-1}}{2} \right) (s_i - s_{i-1}) \quad (36)$$

The series can be rewritten to show the physical characteristics as:

$$R \approx \underbrace{-\left(\frac{p_0 + p_1}{2}\right)(s_0 - s_1)}_{p_1 \text{ shared}} - \underbrace{\left(\frac{p_1 + p_2}{2}\right)(s_1 - s_2)}_{p_2 \text{ shared}} - \underbrace{\left(\frac{p_2 + p_3}{2}\right)(s_2 - s_3)}_{s_2 \text{ shared}} + \dots \quad (37)$$

Choose a particular data pair, say the n^{th} traverse point, and determine its contribution to the uncertainty in the total integral. Choose "n" other than the first or last pairs, since those are not shared and require special discussion. Examination of Eq. (37) shows that there will be two terms involving each position measurement and two terms involving each probe reading. The value p_n occurs once for $i=n$ and once for $i=n+1$. These two terms are required to include all the effect of p_n .

$$R = \sum_{i=1}^N \dots \frac{p_n}{2} (s_n - s_{n-1}) + \frac{p_n}{2} (s_{n+1} - s_n) + \dots$$

$$= \sum_{i=1}^N \dots p_n \left(\frac{s_{n+1} - s_{n-1}}{2} \right) + \dots$$

leading to:
$$\frac{\partial R}{\partial p_n} = \frac{s_{n+1} - s_{n-1}}{2} \quad (38)$$

Similarly the n^{th} position value, s_n , occurs in two terms leading to

$$\frac{\partial R}{\partial s_n} = \frac{p_{n-1} - p_{n+1}}{2} \quad (39)$$

The first and last pairs (s_0, p_0 , and s_N, p_N) occur only once each yielding

$$\frac{\partial R}{\partial p_0} = \frac{s_1 - s_0}{2} \quad \frac{\partial R}{\partial s_0} = - \frac{p_1 + p_0}{2} \quad (40)$$

$$\frac{\partial R}{\partial p_N} = \frac{s_N - s_{N-1}}{2} \quad \frac{\partial R}{\partial s_N} = \frac{p_N + p_{N-1}}{2} \quad (41)$$

The uncertainty in the integral thus takes on the following form

$$\delta R = \left\{ \left(\frac{s_1 - s_0}{2} \delta p_0 \right)^2 + \left(- \frac{p_1 + p_0}{2} \delta s_0 \right)^2 \right.$$

$$\left. + \sum_{n=2}^{N-2} \left(\frac{s_{n+1} - s_{n-1}}{2} \delta p_n \right)^2 + \sum_{n=2}^{N-2} \left(\frac{p_{n-1} - p_{n+1}}{2} \delta s_n \right)^2 \right.$$

$$+ \left(\frac{s_N - s_{N-1}}{2} \delta p_N \right)^2 + \left(\frac{p_N + p_{N-1}}{2} \delta s_N \right)^2 \Bigg\}^{1/2} \quad (42)$$

While it would be a tedious proposition to evaluate this by hand, it is not so formidable to program it once and store it as a library subroutine.

ROBERT J. MOFFAT

Supplementary Notes on Uncertainty Analysis

Consider an experiment designed to permit a result, R , to be calculated based on data: $x_1, x_2, x_3 \dots x_n$. The apparatus can be considered as "fixed" during the experiment; each descriptor of the apparatus is a parameter of the problem: $p_1, p_2, p_3 \dots p_k$. The set-point of the apparatus is described by a known set of independent variables: $i_1, i_2, i_3 \dots i_m$ which include the ambient conditions. The nature of the apparatus, in combination with the set-point variables, acting through the processes involved, produce a set of dependent outputs: $d_1, d_2, d_3 \dots d_n$.

A complete list of descriptors would suffice to "recreate" the experiment exactly if the processes involved were deterministic. This list of descriptors contains what would be called the "data" of the experiment, plus a good deal more.

Descriptors: $i_1, i_2, i_3 \dots i_m, d_1, d_2, d_3, \dots d_n; p_1, p_2, p_3 \dots p_k$
independent and dependent variables parameters of the experiment
(set point, ambient, outcome; every variable which affects the outcome) (size, shape, location)

The list of "data" recorded for any real experiment is only part of the list of independent and dependent variables: usually only those pieces of information which allow the result, R , to be calculated, and the conditions of the test to be identified.

Assume that the result, R , can be calculated using only certain data, for example, suppose that a computer code exists for calculating R :

$$R = R(i_1, i_2, i_3, d_1, d_2, d_3, d_4)$$

The data used in calculating R contain some (but not all) of the independent variables and some (but not all) of the dependent variables. When

this truncated list is adopted as sufficient, it is presumed that fixing i_1 , i_2 , and i_3 will fix the state of the experiment, hence fixing values of d_1 , d_2 , d_3 , and d_4 . If, in fact, the dependent variables are affected by i_4 , i_5 , i_6 , or other "unrecorded" independent variables, then the calculated values of R will be different on repeated trials, whenever i_4 , i_5 , and i_6 are different, even if i_1 , i_2 , and i_3 are held fixed. This outcome is described as "scatter."

If engineering measurements were always free of error and absolutely precise, then "scatter" on repeated trials of the same set point would be a clear indicator that recorded variables were affecting the process. Such is not the case. Individual measurements suffer from errors due to calibration, installation and interpretation defects, and these errors can also cause "scatter" upon repeated trials.

The objective of Uncertainty Analysis, as a diagnostic tool, is to evaluate the amount of "scatter" which can be attributed to the recognized uncertainties in the input data, and thereby make it possible to identify the presence of significant unrecorded variables in the experiment.

In all of the following sections, the emphasis will be on calculating the amount of uncertainty in the result, R , given the list of data used in calculating R , and assuming that the equations are known by which R is calculated from the data.

No uncertainty analysis can begin until the data reduction program has been written. No data-gathering experiment should proceed until it has been shown that the scatter in the result, upon repeated trials, is reasonable, considering the inputs.

It should always be borne in mind that there are stochastic processes in nature -- sometimes systems simply do not repeat their detailed behavior. Usually, however, engineering experiments are conceived as deterministic, and one has a right to expect repeatability within limits.

APPENDIX N
DRAWINGS, PROCESSES, SPECIFICATIONS OF THE
601156 LOW PROFILE TRANSDUCER FINAL DESIGN
SENSO-METRICS, INC.

CONTENTS

Section		Page
N-1	Transducer Drawing Guide and Parts List	N-563
N-2	Low Profile Transducer Design Drawings	N-569
N-3	Preparation of Gaging Surface	N-589
N-4	Semiconductor Strain Gage Installation Procedure	N-593
N-5	Epoxy Filtering Procedure	N-611
N-6	15-5 Stainless Steel Metal Conditioning Process	N-613
N-7	Technical Specification for Homogeneous Semiconductor Strain Gages	N-615

N-1 TRANSDUCER DRAWING GUIDE AND PARTS LIST

N-563

PRECEDING PAGE BLANK - NOT FILMED

CUSTOMER UTC
SPEC NO. _____

OUTLINE (TOP) DRAWING
NAME STRAIN XDUCCER
DWG NO 601156
IIRS _____
SIZE C

TYPE OF DMGS REQD _____
TOTAL IIRS REQD _____

DESIGN LAYOUT
SK NO. 601156
IIRS _____
SIZE _____

FINAL ASSEMBLY DWG.
DWG NO 800036
IIRS _____
SIZE C

PARTS LIST
P/L NO 601156
IIRS _____
SUITS A

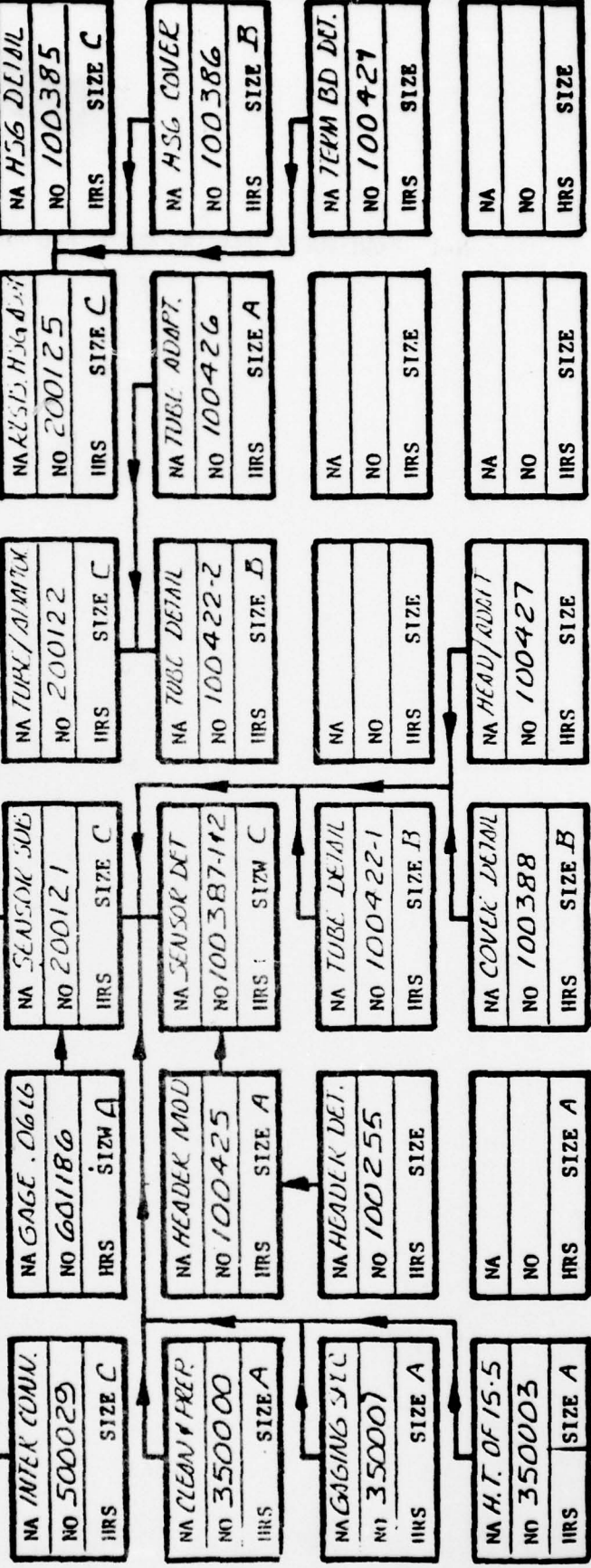

APPROVED BY _____
DATE _____

APPROVED BY _____
DATE _____

PREP BY 6-78
DATE _____

PREP BY GAD
DATE _____

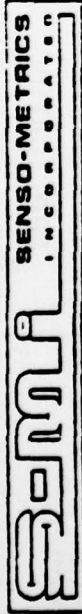

ENGINEERING PARTS LIST

CODE IDENT NO.
51895

PL 601156 TITLE STRAIN TRANSDUCER PL. REV. ISSUE DATE 6-1-71 REVISION DATE 1-1-71 PAGE 2 OF 4

SEQ. NO.	PART NUMBER	QTY	NOMENCLATURE	UNITS NEXT FINAL ASSY. ART.	PL REV	ZNS	NEXT ASSY. NO.	MANUFACTURING CODES				REMARKS
								PART CODE	T	L-S	F	
—	601156		OUTLINE DWG.	REF DWG			601156					
—	500029		WIRING DIAGRAM	REF DWG			601156					
—	350000		SURFACE PREP	REF DWG			MULTI					
—	350001		SPECIFICATION GAGING	REF DWG			MULTI					
—	350003		SPECIFICATION H.T.	REF DWG			MULTI					
—	800036		Specification 15-5 FINAL ASSEMBLY TRANSDUCER	1 1			601156					SEE SEPERATE PRICE LIST
—	200121		SENSOR SUB ASSEMBLY	1 1			800036					100 PSI Δ
1	100387-1		SENSOR DETAIL	1 1			200121					1000 PSI Δ
1	100387-2		SENSOR DETAIL	1 1			200121					1000 PSI Δ
2	100422-1		TUBE .091 O.D.	1 1			200121					
3	100427		HEADER ADAPTER	1 1			200121					
4	601186		GAGE .06 LG.	4 4			200121					
5	T-25		SOLDER TAB	5 5			200121					
6	6203 FF		EPOXYLITE	A/R A/R			200121					ABLESTIK
7	60 Sn/40 Pb WRP		SOLDER TIN/LEAD	A/R A/R			200121					QQ-S-571
8	100425		HEADER MOD.	1 1			200121					
—	100255		HEADER	1 1			100425					
9				—								

DISTR CODE

PREPARED BY

APPROVED

JUN 22 1978

F = FLOOR STOCK
 T = TOOLING
 L-S = LINE ASSY.
 S = STOCK
 DS = STOCK
 SA = STOCK ASSY. ONLY



ENGINEERING PARTS LIST

CODE IDENT NO.
51895

PL 601156 TITLE STRAIN TRANSDUCER P/N REV. ISSUE DATE 16/78 REVISION DATE 1-1-1 PAGE 3 OF 4

SEQ NO.	PART NUMBER	QTY	NOMENCLATURE	UNITS NEXT FINAL ASSY ART.	PL REV	SIZE	MFGT ASSY. NO.	MANUFACTURING CODES				REMARKS	
								PART CODE	T	L-S	F		TAB CODE
10	100388		COVER DETAIL	1			200121						
11	NLORO		BRAZE MIT. WIRE SOLID 30	A/R	A/R		200121						WESTERN GOLD & PLATINUM
12	BTK-30-0	0	KAYNAR BLK WIRE SOLID 30	A/R	A/R		200121						BER-TEK
13	BTK-30-2	2	KAYNAR RED WIRE SOLID 30	A/R	A/R		200121						BER-TEK
14	BTK-30-4	4	KAYNAR YELLOW WIRE SOLID 30	A/R	A/R		200121						BER-TEK
15	BTK-30-5	5	KAYNAR GREEN WIRE SOLID 30	A/R	A/R		200121						BER-TEK
16	BTK-30-9	9	KAYNAR WHITE WIRE SOLID 30	A/R	A/R		200121						BER-TEK
	200122		ADAPTER/TUBE	1			800036						
	100426		HEADER ADAPTER	1			200122						
	100422-1		TUBE .125 O.D.	1			200122						
	NLORO		BRAZE METAL WIRE 28 AWG	A/R	A/R		200122						WESTERN GOLD & PLATINUM
	1050-59-0		TEFLON BLK WIRE 28 AWG	A/R	A/R		200122						
	1050-59-2		TEFLON RED WIRE 28 AWG	A/R	A/R		200122						
	1050-59-4		TEFLON YELLOW WIRE 28 AWG	A/R	A/R		200122						
	1050-59-5		TEFLON GREEN WIRE 28 AWG	A/R	A/R		200122						
	1050-59-9		TEFLON WHITE WIRE 28 AWG	A/R	A/R		200122						
	200125		HSG. SUB-ASSY	1			601156						
	100385		HSG. DETAIL	1			200125						

JUN 2 1978

PART CODE PETS PI
F = FLOOR STOCK
L-S = TOOLING
T = TAB CODE
S = STOCK
D = STOCK
SA = STOCK ASSY. ONLY

DISTR CODE

PREPARED BY

APPROVED



SENSOMETRICS
INCORPORATED

ENGINEERING PARTS LIST

UNCL IDENT NO.
51895

PL 601156 TITLE STRAIN TRANSDUCER REV 1 DATE 10/1/70 REVISION DATE 1/1/71 PAGE 4 OF 4

SEQ NO.	PART NUMBER	QTY	NOMENCLATURE	UNIT OF MEASUREMENT	UNIT PRICE	TOTAL AMOUNT	NEXT ASSY. NO.	MANUFACTURING CODES				REMARKS
								PART CON	T	L S	F	
-	100386		COVER DETAIL		1	1	200125					
-	100421		P.C. BOARD		1	1	200125					
-	2035A		TERMINAL		5	5	100421					
-	2002A		TERMINAL		2	2	100421					
-	PT02A-10-6S		ELECT. CONNECTOR		1	1	200125					BENDIX
-	SS-200-6		TUBE CONNECTOR		1	1	200125					
-	2-56		82° CSK SCREW, 3/8 LG		3	3	200125					
-	2-56		82° CSK SCREW, 2 1/2 LG		3	3	200125					
-	2-56		HEX NUT		3	3	200125					
-	9222-N-115		SPACER 1/4" x 1/8 LG		3	3	200125					AMATOM
-	4-40		CAP SCREW 1/4 LG		4	4	200125					
-	8343ET28-10		WIRE 28 AWG		A/R	A/R	200125					STD WIRE & CABLE
-	60 SN/40PB WRP		TEFLON BLK		A/R	A/R	200125					QQ-S-571
-	GRADE "C"		SOLDER TIN/LEAD		A/R	A/R	200125					LOCTITE
-	182		SEALANT (BLUE)		A/R	A/R	200125					
-	RN 55C T.B.D.		POTTING MATERIAL		A/R	A/R	601156					
-			RESIS. VALVE THD		THD	THD	601156					

APPROVED: _____ PREPARED BY: _____

DISTR CODE: _____

LEGEND:
 F = FLOOR STOCK
 T = TOOLING
 L-S = STOCK
 L = WIRE ASSY
 S = STOCK ASSY
 SA = STOCK ASSY ONLY

PART CODE PER SPI

JUN 29 1978

N-2 Low Profile Transducer Design Drawings



N-569

REV.	CLASS	DASH NO.	CODE	ZONE	DATE	APPROVAL

REVISIONS

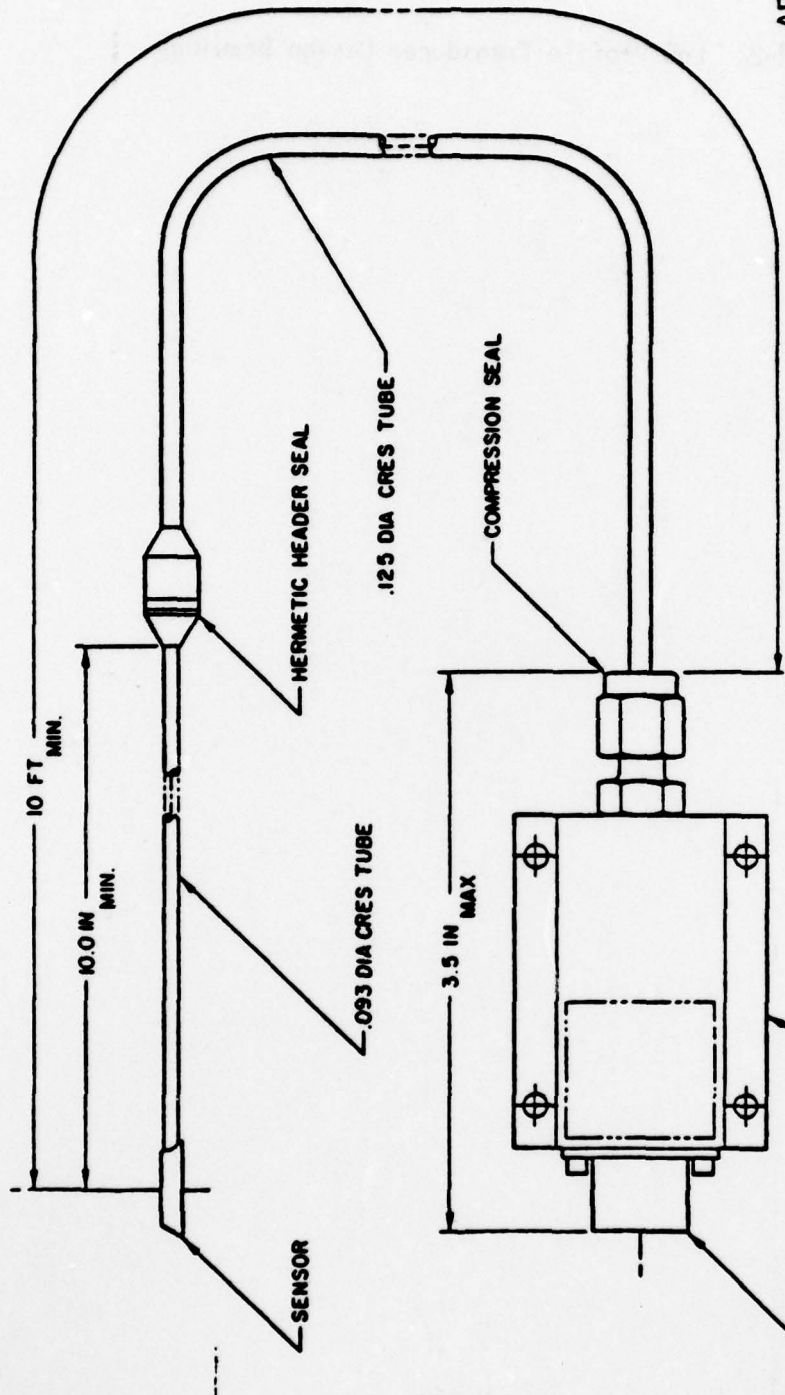

APR 21 1971

DASH NO.	BASIC ZONE	PART NUMBER	CODE IDENT	DESCRIPTION	REFERENCE DESIGNATOR	TITLE

CONTRACT NO.	RECD PER ASSY	TITLE

DRIVEN BY	CHECKER	US SIGNER	WECN APPR	ELEC APPR	APPROVED
G.A.J.					

MATERIAL	FINISH	HEAT TREAT	USED ON
UNLESS OTHERWISE SPECIFIED MIL-PRC-13100 PER MIL STD 131 WITH AIR IN FINISH UNLESS OTHERWISE SPECIFIED DIA TO BE METAL FINISH STANDARD HILLS PER ANODIZING SURFACE ROUGHNESS $\sqrt{\quad}$ CUSTOMER & SPEC SIMILAR TO			601156

SCALE	CODE IDENT NO	DWG NO.	SHEET	TOTAL
C	51895	601156	2	3

CONTRACT NO.	RECD PER ASSY	TITLE

DRIVEN BY	CHECKER	US SIGNER	WECN APPR	ELEC APPR	APPROVED
G.A.J.					

MATERIAL	FINISH	HEAT TREAT	USED ON
UNLESS OTHERWISE SPECIFIED MIL-PRC-13100 PER MIL STD 131 WITH AIR IN FINISH UNLESS OTHERWISE SPECIFIED DIA TO BE METAL FINISH STANDARD HILLS PER ANODIZING SURFACE ROUGHNESS $\sqrt{\quad}$ CUSTOMER & SPEC SIMILAR TO			601156

1. FOR OUTLINE INFORMATION SEE SHEET NO. 2 AND 3.
NOTES: UNLESS OTHERWISE SPECIFIED

REV. NO.	DATE	BY	APPROVED

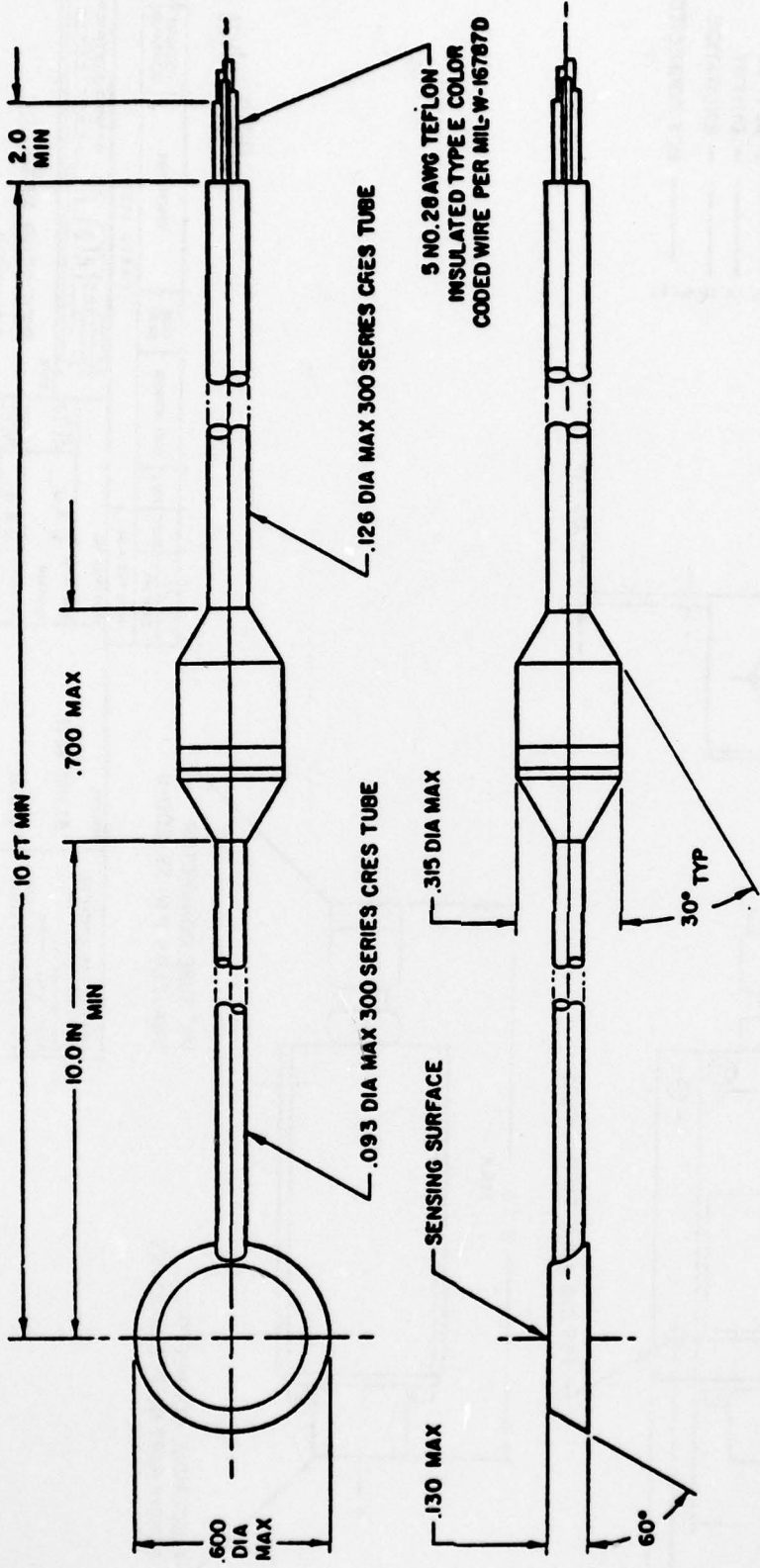

5 NO. 28AWG TEFLON
INSULATED TYPE E COLOR
CODED WIRE PER MIL-W-16787D

.126 DIA MAX 300 SERIES CRES TUBE

.093 DIA MAX 300 SERIES CRES TUBE

.315 DIA MAX

30° TYP

.130 MAX

60°

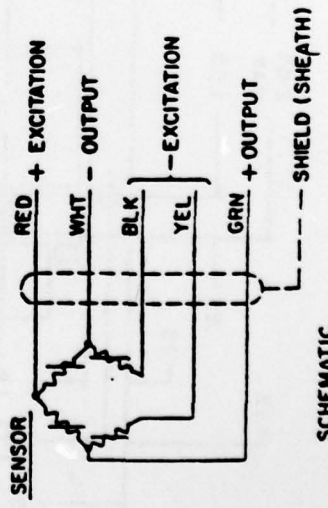

APR 21 1976

DASH NO.	BASIC ZONE	PART NUMBER	CODE	DESCRIPTION	REFERENCE	ITEM
RECD PER ASSY						
CONTRACT NO.						
DRAWN BY G.A.J.						
CHECKER						
DESIGNER G.A.J.						
MECH APPR						
ELEC APPR						
APPROVED						
MATERIAL						
SENSOR BODY MTL:						
15-5 CRES						
HEAT TREAT						
PER 350003						
FINISH						
PER 350003						
NET WT ASSY						
601156						
USED GRN						
601156						
CUSTOMER & SPEC						
SIMILAR TO						
TITLE						
BAND BEND-METRICS						
STRAIN SENSOR						
SIZE	CODE	IDENT NO	FORM NO.			
C	51895	601156				
SCALE 4/1				SHEET 2 of 3		

NOTES UNLESS OTHERWISE SPECIFIED

REV	CLASS	DATE	DESCRIPTION	BY	APP'D

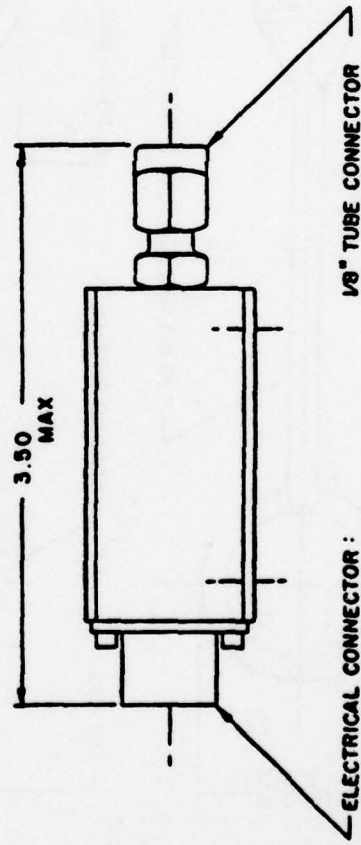
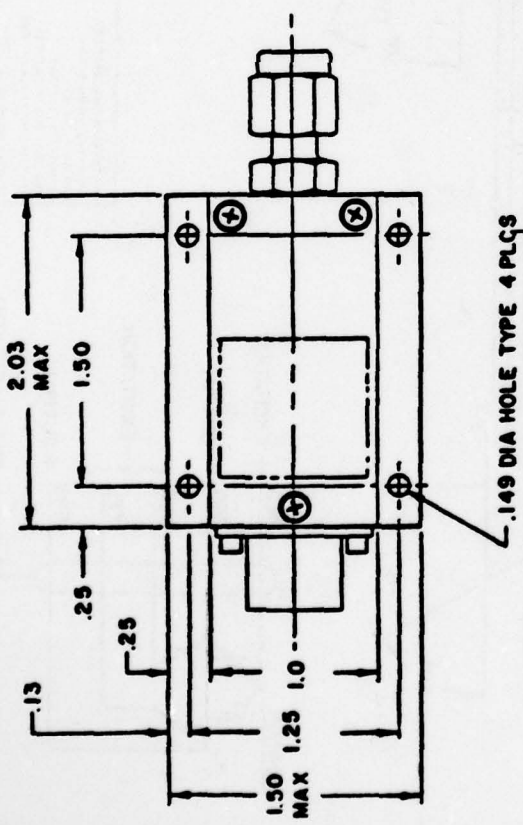
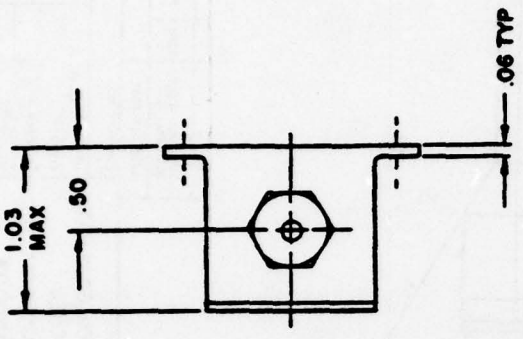

ELECT. CONN	FUNCTION
A	+ EXCITATION
B	+ OUTPUT
C	- OUTPUT
D	- EXCITATION
E	NOT CONNECTED
F	NOT CONNECTED

APR 21 1970

DRG NO	DRG ZONE	PART NUMBER	DESCRIPTION	REFERENCE	REV

CONTRACT NO.	
DRAWN BY	G. A. J. 10-77
CHECKED BY	G. A. J. 10-77
MACH APPR	
ELEC APPR	
APPROVED	

MATERIAL	ALUMINUM
TREAT TREAT	
FINISH	BLUE ANODIZE
MAT ASSY	601156
USED ON	601156

BENDIX	
RESISTOR NETWORK HOUSING	
SHEET NO	3 of 3
SIZE	C 51895
DRG NO	601156
SCALE	2/1

UNLESS OTHERWISE SPECIFIED
DIMENSIONS ARE IN INCHES
DIMENSIONS ARE TO BE MAINTAINED
FINISH TO BE MAINTAINED
SURFACE ROUGHNESS
CUSTOMER & SPEC
SIMILAR TO

NOTES UNLESS OTHERWISE SPECIFIED

REV. CLASS		CODE		ZONE		LTR		DESCRIPTION		DATE APPROVED	
A REVISED HOOKUP INFORMATION										3	11

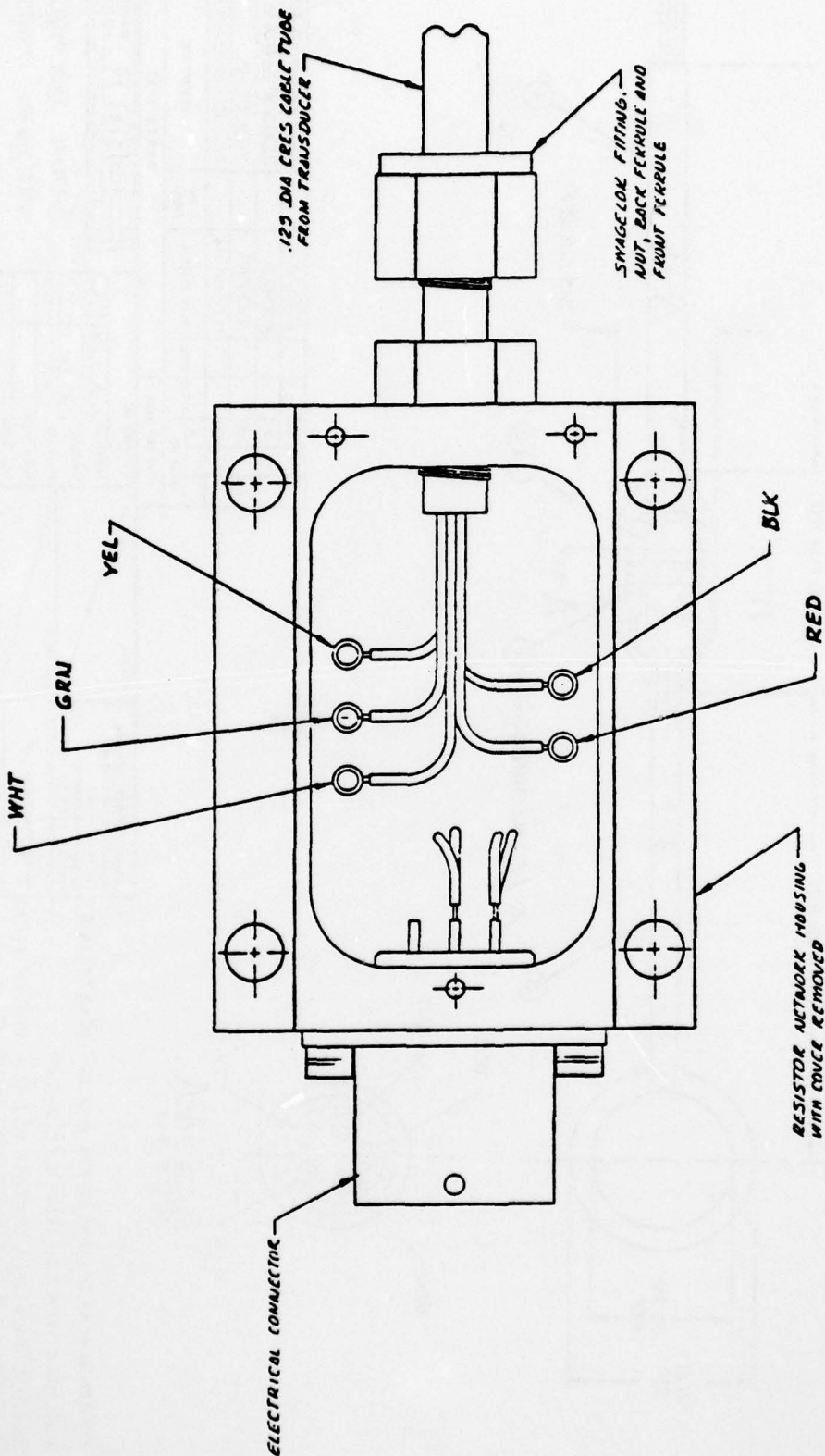

DASH NO.	BASIC ZONE	PART NUMBER	CODE IDENT	DESCRIPTION	REFERENCE DESIGNATOR	ITEM NO.
RECD PER ASSY						
CONTRACT NO.						
DRAWN BY B. M. L. (L)						
CHECKED BY [Signature]						
DESIGNED BY [Signature]						
MECH APPR [Signature]						
ELEC APPR						
APPROVED						

GEM		SENDO-METRICS	
TITLE			
INDUCTIVE TRANSDUCER DATA			
FOR TRANSDUCER 601156			
SIZE	CODE IDENT NO	DWG NO.	SHEET
C	51895	500024	1
SCALE 4:1		WT	

MATERIAL		HEAT TREAT		FINISH		NEXT ASY		USED ON	
UNLESS OTHERWISE SPECIFIED IN DRAWING PER MIL STD-100 DIM ARE IN INCHES DO NOT SCALE DRAWING DIM TO BE MET AT ALL FINISH STANDARD HOLES PL AND DRILL SURFACE ROUGHNESS CUSTOMER & SPEC 1/16" SIMILAR TO								601156	

2. SOLDER LEAD WIRES TO TERMINALS IN RESISTOR NETWORK HOUSING AS SHOWN.
1. ASSEMBLE TRANSDUCER TUBE INTO FITTING PER SWAGELOK INSTALLATION INSTRUCTIONS STEPS 1, 2 AND 3. NOTES UNLESS OTHERWISE SPECIFIED

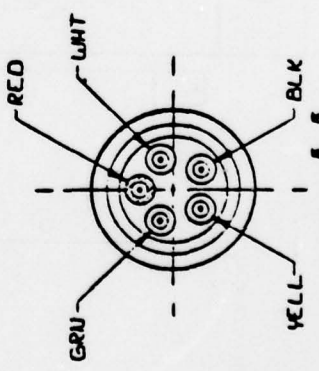
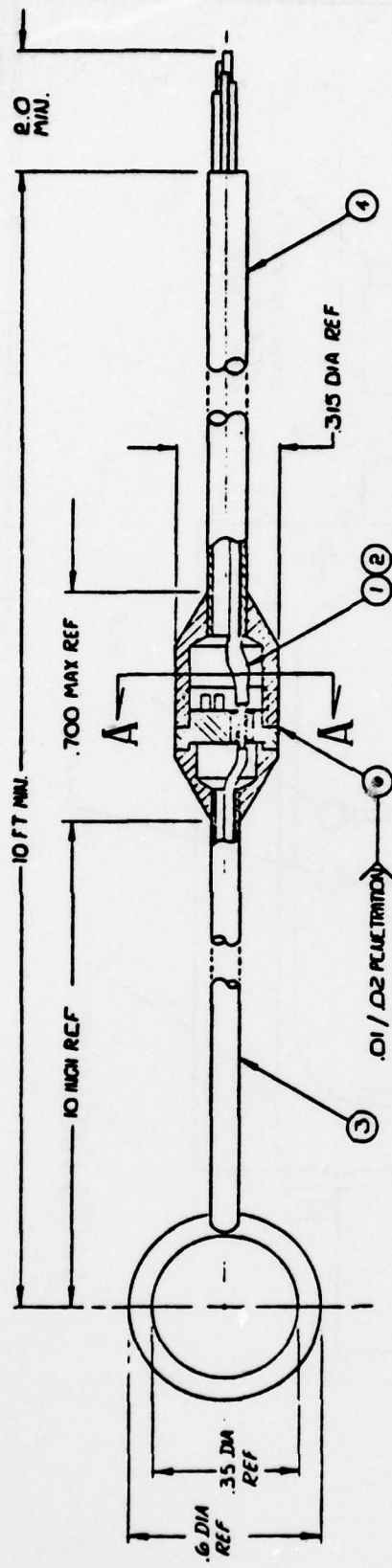

SECTION A-A
SCALE 4:1

QTY	DESCRIPTION	PART NUMBER	CODE IDENT	DESCRIPTION	ITEM REFERENCE	REVISION NO
1	HEAD P. AMPHENOL ASSY	100122				
1	SENSOR SUB-ASSY	200121				
1	SOLDER	60/40				
1	TEL. DIAL INSUL. TUBING (1/16")	FIT-500 P-4				

PARTS LIST

CONTRACT NO. _____

DRAWN BY B. ALLEN

CHECKER [Signature]

DESIGNER [Signature]

MECH APPR [Signature]

ELEC APPR [Signature]

APPROVED [Signature]

DATE: 3-10-56

SCALE: 3/16" = 1"

TITLE: FINAL ASSEMBLY PRESSURE TRANSDUCER

SIZE: CODE IDENT NO: C 51895, DIMG NO: 800036

SCALE: 4:1, WT: _____, SHEET: 1 OF 1

MATERIAL	HEAT TREAT	FINISH	USED ON
UNLESS OTHERWISE SPECIFIED WHY DRG PER MIL STD-100 DIM ARE IN INCHES DO NOT SCALE DRAWING DIM TO BE MET AFTER FINISH STANDARD HOLES PER ANSIBOBY SURFACE ROUGHNESS $\sqrt{\quad}$			60156
CUSTOMER & SPEC	UTC		
SIMILAR TO			

- 3 ELECTRON BEAM WELD AS SHOWN .01 / .02 PENETRATION
- 2 ASSEMBLE ITEM 3 TO ITEM 4 AS SHOWN,
- 1 SOLDER (L) AND (R) OF ITEM 3 TO LEAD WIRE OF ITEM 4 USING ITEM 2 AND INSULATE USING ITEM 1.

NOTES UNLESS OTHERWISE SPECIFIED

AD-A073 660

UNITED TECHNOLOGIES CORP SUNNYVALE CALIF CHEMICAL SY--ETC F/G 9/1
THE DEVELOPMENT OF IMPROVED NORMAL STRESS TRANSDUCERS FOR PROPE--ETC(U)
JUN 79 E C FRANCIS, R E THOMPSON, W E BRIGGS F04611-75-C-0042

UNCLASSIFIED

CSD-2548-FR-VOL-2

AFRPL-TR-79-34-VOL-2

NL

4 OF 4

AD
A073660

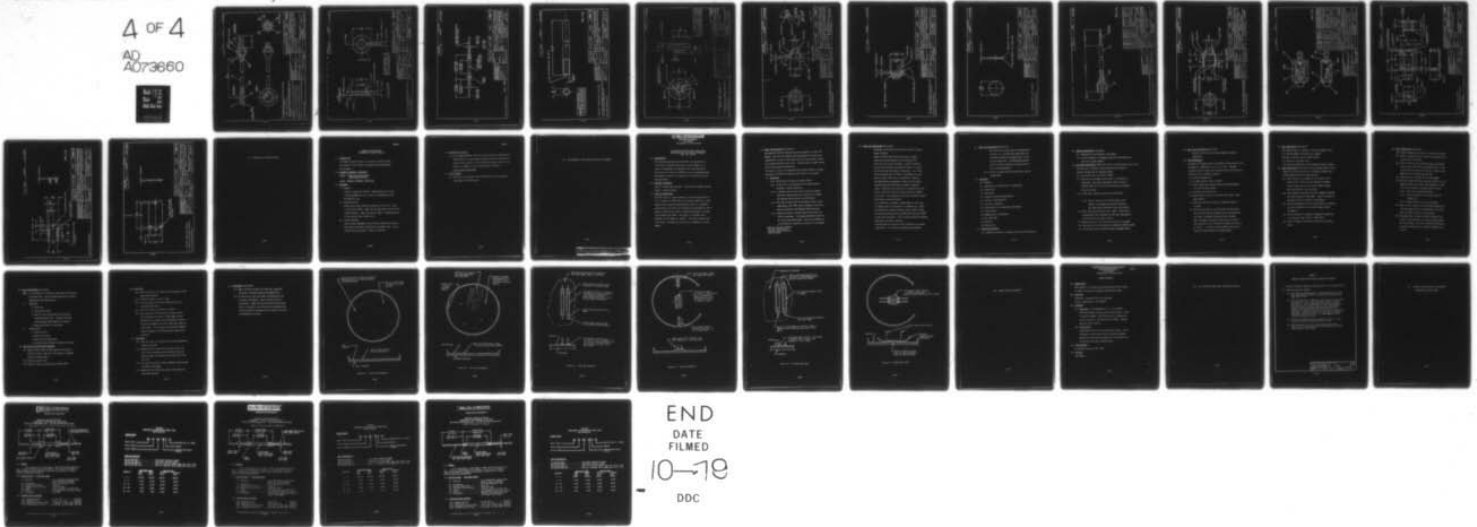

END
DATE
FILMED
10-79
DDC

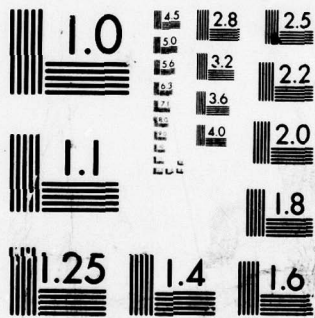

MICROCOPY RESOLUTION TEST CHART
NATIONAL BUREAU OF STANDARDS-1963-A

DATE APPROVAL

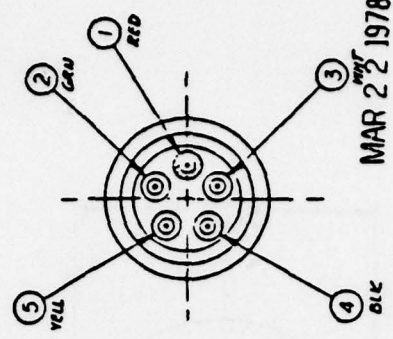
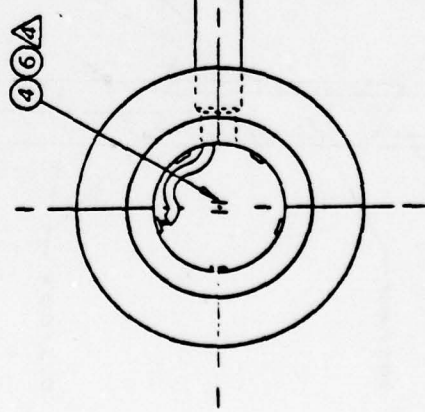
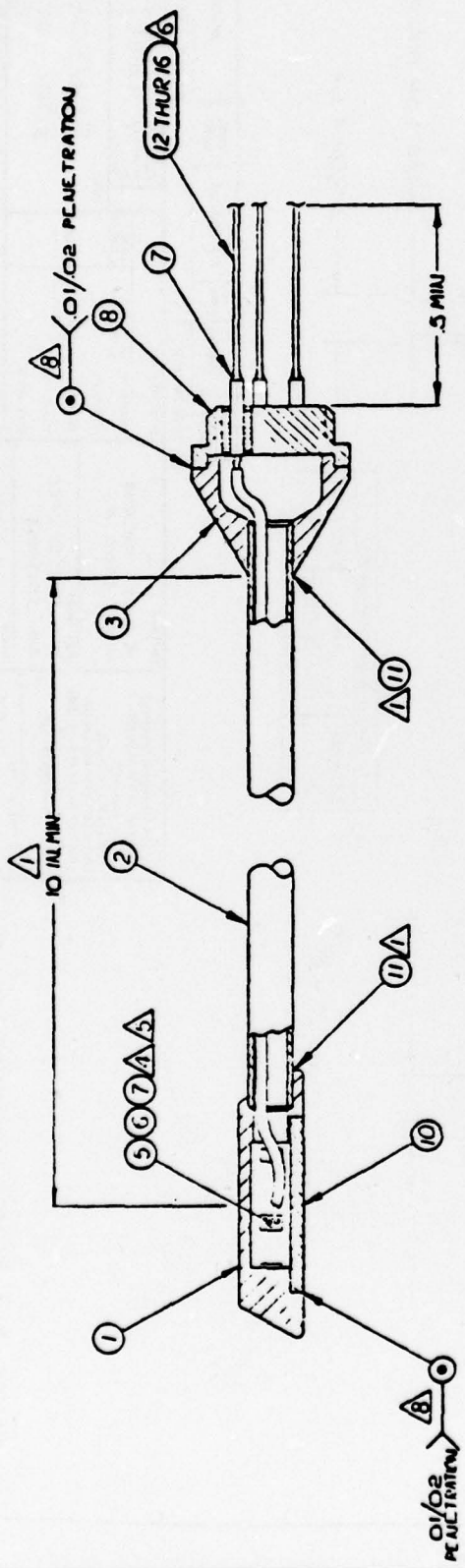

MAR 22 1978

- A ELECTRON BEAM WELD ITEM 10 INTO ITEM 1 AND ITEM 8 AND ITEM 3 AS SHOWN.
 7 INSTALL ITEM 10 INTO ITEM 1
 8 INSTALL ITEM 12 THUR 16 INTO ITEM 1 AND ITEM 6. REMOVE AND SOLDER ITEM 12 THUR 16 USING ITEM 7, AS SHOWN.
 A INSURE ITEM 5 USING ITEM 6 AND CURE AT 200°F FOR 2 HRS MIN.
 A CABLE PER 350001 WITH ITEM 4 USING ITEM 6.
 3 CLEAN AND PREP DIAPHRAGM AREA PER 350000.
 A HEAT TREAT ITEM 1, 2 AND 3 PER 350003 PER 350003.
 A HOLE ITEM 2 INTO ITEM 1 AND ITEM 3 USING ITEM 11 TO DRILL.
 NOTES UNLESS OTHERWISE SPECIFIED

SEE SEPARATE PARTS LIST.

DASH NO.	BASIC ZONE	PART NUMBER	DESCRIPTION	REFERENCE ITEM NO.
RECD PER ASSY <td></td> <td></td> <td></td> <td></td>				
CONTRACT NO.				
DRAWN BY: ALLEU DATE: 3/17/78				
CHECKED: DATE: 3/17/78				
DESIGNER: DATE: 3/16/78				
MECH APPR:				
ELEC APPR:				
APPROVED:				
MATERIAL:				
HEAT TREAT: A				
FINISH:				
PART ASSY: USED ON 601156				
UNLESS OTHERWISE SPECIFIED IN P&ID: PER MIL STD-100 DIM ARE IN INCHES DO NOT SCALE DRAWING DIM TO BE MET AFTER FINISH STANDARD HOLES PER AND/OR SURFACE ROUGHNESS CUSTOMER & SPEC (I.T.C.) SIMILAR TO				

BENTON SENSOMETRICS
 TITLE: SENSOR SUB - A394
 SIZE: C 51895
 CODE IDENT NO: 200121
 SCALE: 1:1
 SHEET 1 OF 1

REL CLASS	DISIR CODE	LTR	REVISIONS	DESCRIPTION	DATE	APPROVED

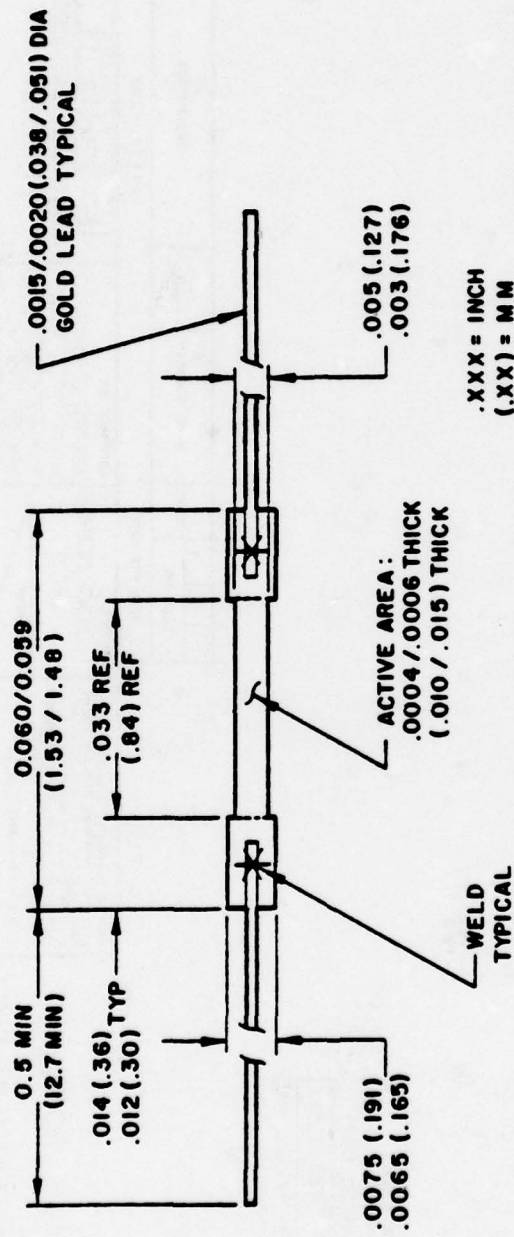

DASH NO.	BASIC	PART NUMBER	CODE	DESCRIPTION	REFERENCE	ITEM
					DESIGNATOR	NO
REQD PER ASSY		PARTS LIST				
MATERIAL		CONTRACT NO.				
HEAT TREAT		DRAWN BY G.A.J. DATE 2/78				
FINISH		CHECKED				
HEAT ASSEMBLY USED ON		DESIGNED				
UNLESS OTHERWISE SPECIFIED INTERPRET DRAWING PER MIL-STD-883C (MIL-STD-883C) DIMENSIONS TO BE MET AFTER FINISH STANDARD INCHES PER ANGIO/77 SURFACE ROUGHNESS ✓		MIL-SPEC APPR				
CUSTOMER & SPEC SIMILAR TO		FILE APPR				
APPROVED		APPROVED				
TITLE		HOMOGENEOUS SEMICONDUCTOR STRAIN GAGE SMI-06-033-500P				
SITE		SITE CODE				
B		51895				
SCALE		60/1 WT				
601186		601186				
SHEET 1 OF 1		SHEET 1 OF 1				

FEB 7 1978

NOTES: UNLESS OTHERWISE SPECIFIED

DESCRIPTION DATE APPROVED

.005 X 45° CHAM MIN OR .005 MIN R.

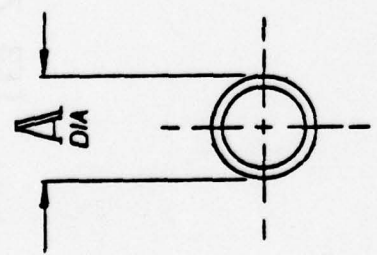
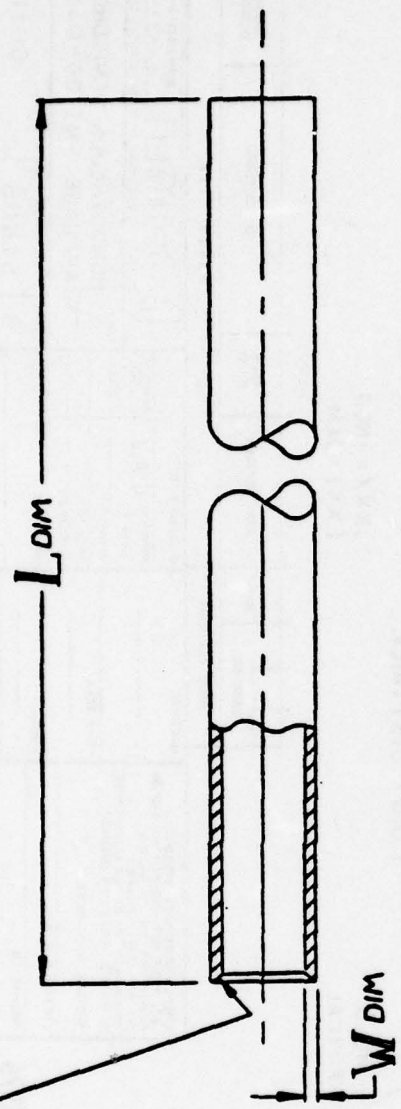

TABLE NUMBER ONE			
DASH NO.	A DIA	W DIM	L DIM
-1	0.945	.015	10.5 IN MIN.
-2	.127 / .124	.010	9 FT. 6 IN. MIN.

N-578

MAR 22 1978

UNLESS OTHERWISE SPECIFIED INTERPRET DRAWING PER MIL-STD-189 DIMENSIONS ARE IN INCHES DIMENSIONS IN PARENTHESES ARE IN MILLIMETERS. DRAWING SHALL BE MADE TO DIMENSIONS UNLESS OTHERWISE SPECIFIED. STANDARD HOLES PER ANSI B92.1 SURFACE ROUGHNESS 6.3		MATERIAL 300 SERIES CARLS		CONTRACT NO. DRAWN BY D. MILN		BENSON-METRICS	
HEAT TREAT		FINISH PASSIVATC		CHECKER		DESCRIPTION TUBC	
CUSTOMER & SPEC SIMILAR TO		HEAT ASST USED ON		DESIGNER		SIZE B	
				ELECTRICAL		CODE IDENT NO. 51895	
				APPROVED		DWG NO. 100422	
				SCALE 10:1		SHEET 1 OF 1	
				PARTS LIST			
				PART NUMBER		REFERENCE DESIGNATOR	
				CODE IDENT		ITEM NO.	
				BASIC			
				DASH NO.			
				REC'D PER ASSY			

2. BREAK ALL SHARP EDGES .005 MIN.
1. ALL DIAS ON A COMMON CENTERLINE SHALL BE CONCENTRIC WITHIN .005 TIR.

NOTES: UNLESS OTHERWISE SPECIFIED

REV	DESCRIPTION	DATE	APPROVED

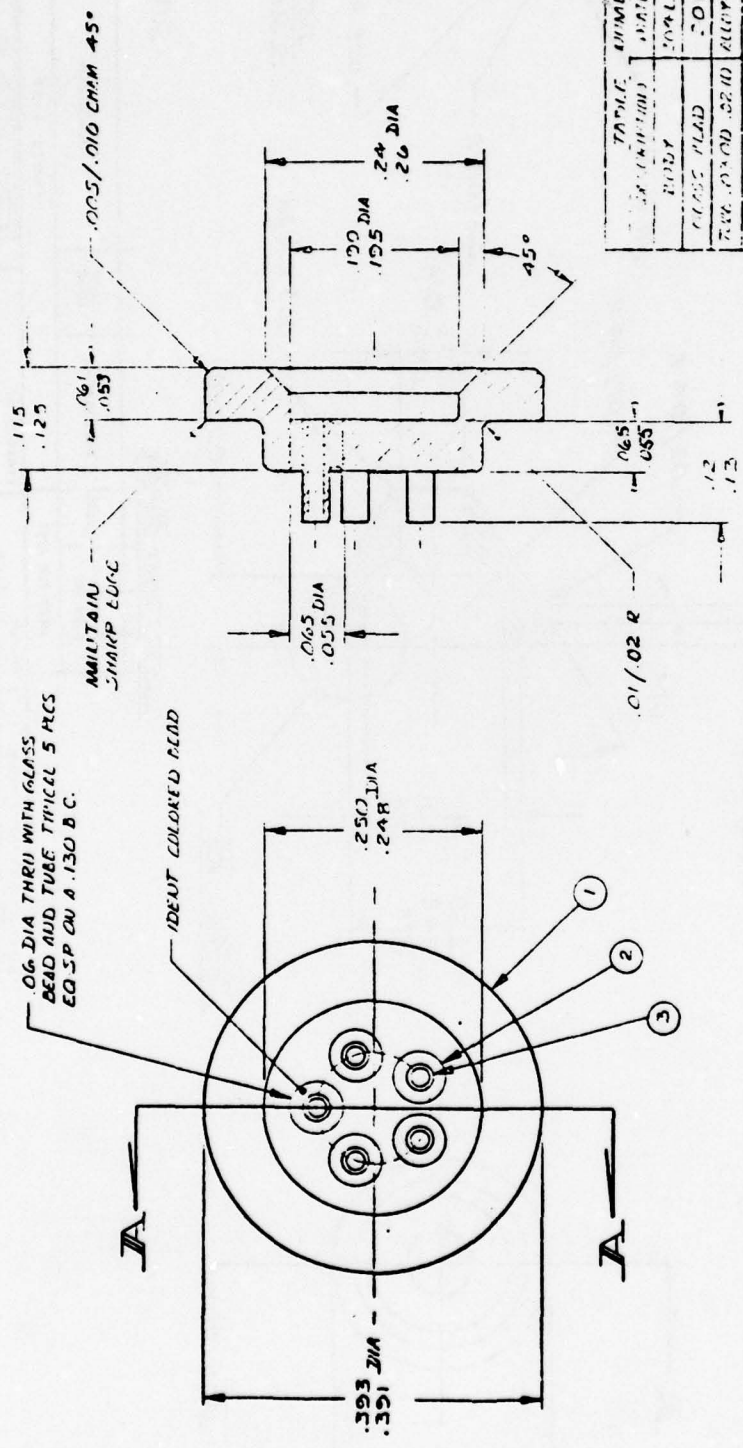

ITEM NO.	QUANTITY	DESCRIPTION	UNIT	REVISION
1	1	GLASS TUBE	EA	1
2	5	GLASS BEAD	EA	2
3	5	GLASS TUBE	EA	3

SEE DRAWING FOR DIMENSIONS

ITEM NO.	DESCRIPTION	REFERENCE ITEM NO.
1	GLASS TUBE	1
2	GLASS BEAD	2
3	GLASS TUBE	3

ITEM NO.	DESCRIPTION	REFERENCE ITEM NO.
1	GLASS TUBE	1
2	GLASS BEAD	2
3	GLASS TUBE	3

- FINISH: ITEM NO. 3 TUBES: LEAD/TIN PLATE
ITEM NO. 1 BODY: PASSIVATE.
- ALL DIAMETERS ON A COMMON CENTERLINE SHALL BE CONCENTRIC WITHIN .003 TIA.

NOTES: UNLESS OTHERWISE SPECIFIED

DESCRIPTION	DATE	APPROVAL

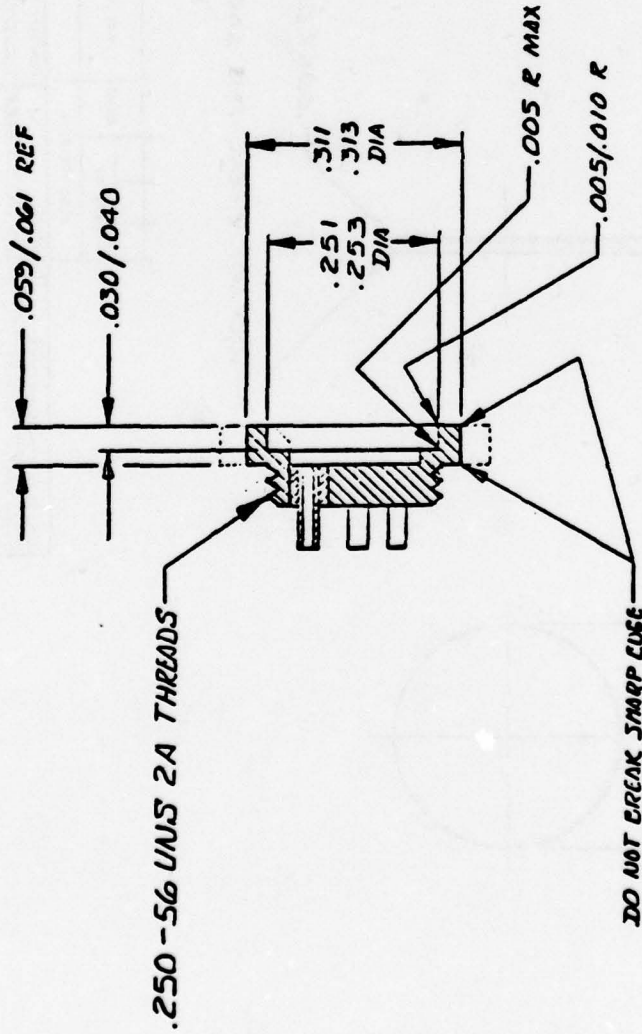

DASH NO.		RECD PER ASSY		MATERIAL MAKE		CONTRACT NO.		PART NUMBER		CORR IDENT		DESCRIPTION		REFERENCE DESIGNATOR	
				FROM 100255		CAD						SENDA		SENDO-METRICS	
						CHECKER		DATE		TITLE		SIZE		CORR IDENT NO. DWG NO.	
						DATE		10/10/71		HEADER MUD TAIL		B		51895 100425	
						HEAT TREAT		APPROVED		SCALE		G X 1		WT	
						FINISH		USLO ON		SCALE		G X 1		WT	
						PASS/ATZ.		10/156		SCALE		G X 1		WT	
						HEAT TREAT				SCALE		G X 1		WT	
										SCALE		G X 1		WT	
										SCALE		G X 1		WT	

UNLESS OTHERWISE SPECIFIED
 INITIATE DRAWING PER MIL-STD-100
 AND NOT SCALE DRAWING
 DIMENSIONS TO UNLESS OTHERWISE SPECIFIED
 STANDARD HOLES PER ANTI
 SURFACE ROUGHNESS 32

CUSTOMER & SPEC UTC
 SIMILAR TO

1. ALL DIAS ON A COMMON CENTERLINE SHALL
 BE CONCENTRIC WITHIN .003 TIR
 NOTES: UNLESS OTHERWISE SPECIFIED

REL CLASS	DISTR CODE	LTR	REVISIONS	DATE	APPROVE
			DESCRIPTION		

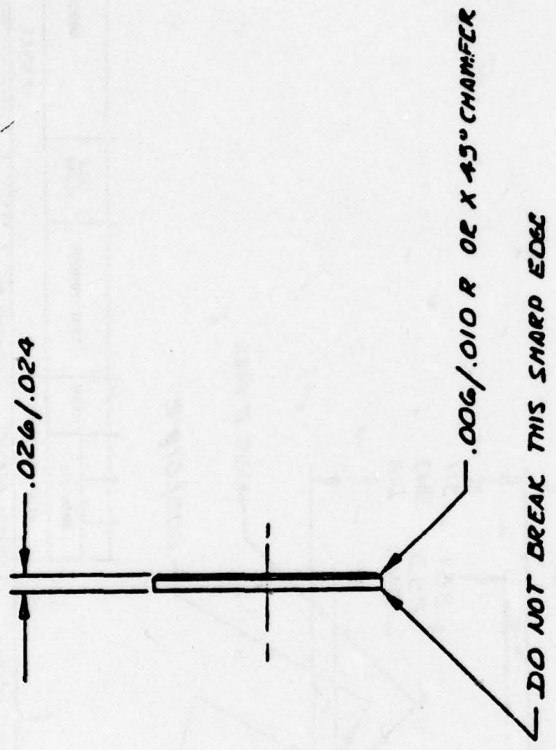
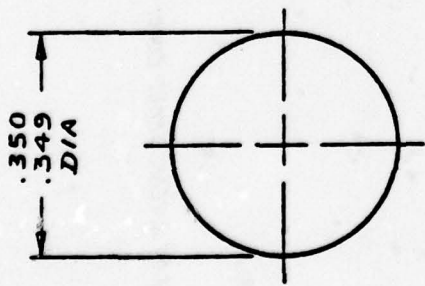

.006/.010 R OR X 45° CHAMFER

1. THIS PART MATES WITH 100387

NOTES: UNLESS OTHERWISE SPECIFIED

DASH NO.	BASIC	PART NUMBER	CODE	DESCRIPTION	REFERENCE DESIGNATOR
REQD PER ASSY		PARTS LIST			
MATERIAL		CONTRACT NO.		GENCO-METRICS	
15-5 CREES VACUUM		DATE 7/71		COVER DETAIL	
MELT COUD A		DRAWN BY GAD		LOW PROFILE	
HEAT TREAT		CHECKED GAD		SIZE CUNE BR/111 NO DWG NO	
PEK 350003		TITLE DATE 10/16/71		B 51895 100388	
FINISH		ILLUSTRATED		SCALE 2 X 1	
PEK 350003		APPROVED		10/17/71	
CUSTOMER & SPEC		WELD ON			
SIMILAR TO		101176			

UNLESS OTHERWISE SPECIFIED
INTERPRET DRAWING PER MIL-STD-189
DO NOT SCALE DRAWING
DIMENSIONS TO BE MET AFTER FINISH
STANCHION HOLES PER ANODIZING
SURFACE ROUGHNESS X7
CUSTOMER & SPEC UTC
SIMILAR TO

REL CLASS	DISTR CODE	LTR	DESCRIPTION	DATE	APPROVED

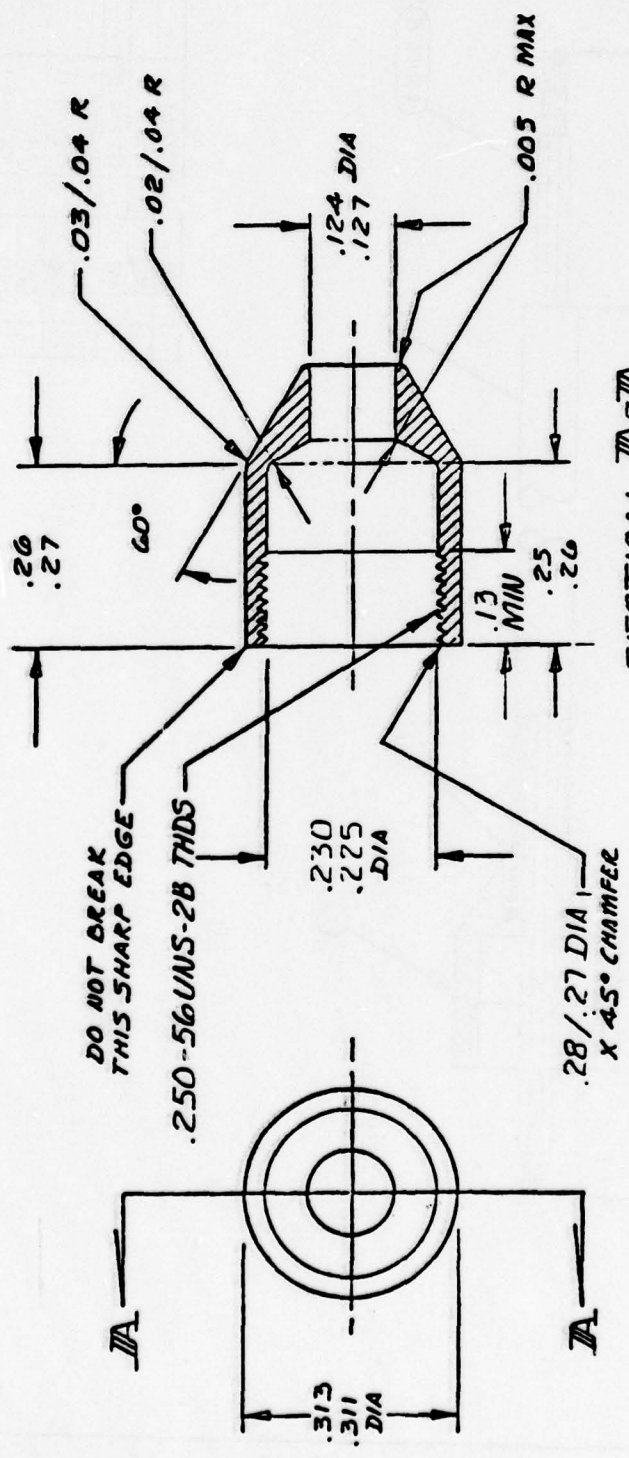

SECTION A-A

DASH NO.		BASIC	PART NUMBER	CODE IDENT	DESCRIPTION	REFERENCE DESIGNATOR	ITEM NO.
RECD PER ASSY							
MATERIAL		CONTRACT NO.		PARTS LIST			
300 SCALES CKES		CAD		BOMBA GENRO-METRICS			
UNLESS OTHERWISE SPECIFIED DIMENSIONS ARE IN INCHES DO NOT SCALE DRAWING DIMENSIONS TO DIMETER FINISH STANDARDS TO DIMETER AND/OR SURFACE FINISH		CHECKED		TITLE			
CUSTOMER & SITE UTC		DATE 10/11/71		HEADER EXIT TUBE			
SIMILAR TO		APPROVED		ADAPTOR DETAIL			
SURFACE FINISH		SIZE		CORAL IDENT NO			
UTC		B		51895			
UTC		DNG NO.		100426			

1. ALL DIAS ON A COMMON CENTERLINE SHALL BE CONCENTRIC WITHIN .003TIR.
 NOTES: UNLESS OTHERWISE SPECIFIED

JUN 29 1978

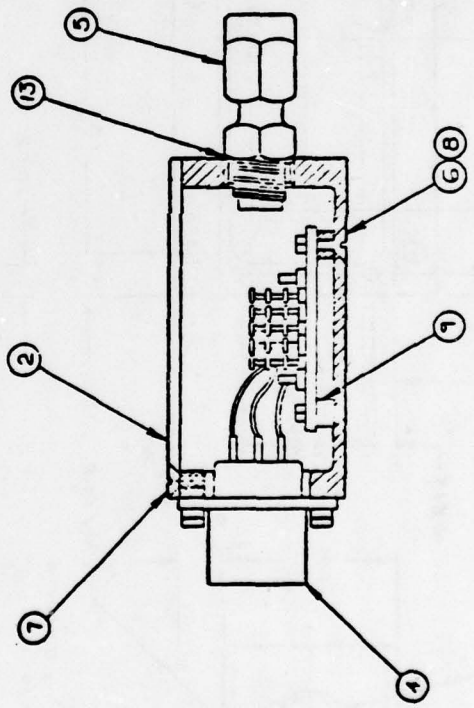
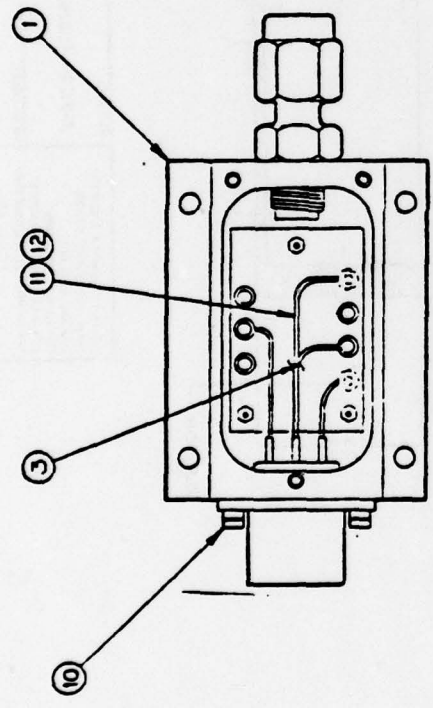

DASH NO.	BASIC ZONE	PART NUMBER	CODE IDENT	DESCRIPTION	REFERENCE ITEM DESIGNATION
				SEALANT (BLUC)	LOCKTITE 13
				SENDER TIN/LEAD	00-5-511 12
				WML 28 ALG TEFLOX	TULLOX 11
				SECT HD CAP SEAL W 1/4 LG	
				WASHER 1/4 OD X 1/8 LG	10
				HGX NUT	AMATOM 7
				82 CSK 3/16 LUS 25 LG	8
				82 CSK 3/16 LUS 25 LG	7
				TUBE CONNECTOR	5
				ELECT CONNECTOR	ESUMEX 4
				P.C BOARD DETAIL	3
				COVER DETAIL	2
				HOUSING DETAIL	1

PARTS LIST

SEMBO-METRIC

RESISTOR NETWORK

HOUSING SUB-ASSY

SIZE: C 51895

CODE IDENT NO: DWG NO. 200125

SCALE: 1/1

SHEET 1 OF 1

CONTRACT NO.

DRAWN BY: B ALLEN

CHECKER: [Signature]

DESIGNER: [Signature]

MECH APPR: [Signature]

ELEC APPR: [Signature]

APPROVED: [Signature]

RECD PER ASSY

MATERIAL: HEAT TREAT

FINISH: UTC

CUSTOMER & SPEC: UTC

SIMILAR TO:

NEAT ASSY: G0115G

USED ON: G0115C

UNLESS OTHERWISE SPECIFIED
 DRAWING PACKAGES SHALL BE
 DIM TO BE MET/AS PER FINISH
 STANDARD HOLES PER ANSI B92
 SURFACE ROUGHNESS ✓
 CUSTOMER & SPEC
 SIMILAR TO

NOTES: UNLESS OTHERWISE SPECIFIED

DESCRIPTION _____ DATE _____ APPROVED _____

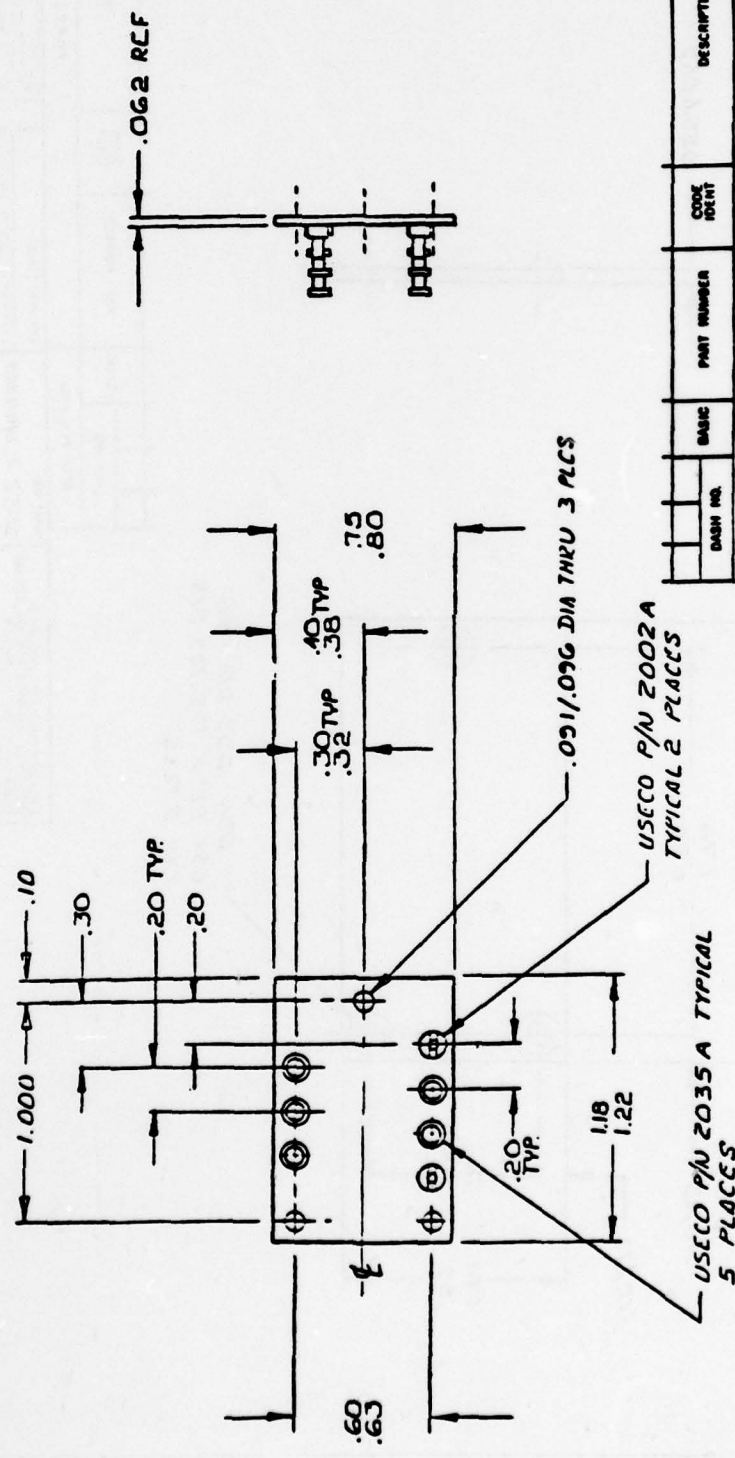

MAR 2 2 1978

DASH NO.		BASIC	PART NUMBER	CODE IDENT	DESCRIPTION	REFERENCE DESIGNATOR	ITEM NO.
NEED PER ASSY		PARTS LIST					
MATERIAL FLGF - 062 OR VCTOR 9D 16-7P84-0620P		CONTRACT NO.		SENBO-METRICS			
UNLESS OTHERWISE SPECIFIED INTERPRET DRAWING PER MIL-STD-187B UNLESS OTHERWISE SPECIFIED. DIMENSIONS TO BE MIL AFTER FINISH STANDARD HOLES PER AND1087 SURFACE ROUGHNESS $\sqrt{\text{ }}$ CUSTOMER & SPEC 1/1C SIMILAR TO Q-3377		DRAWN BY <i>WLD</i>		DATE 3/2			
HEAT TREAT		CHECKED BY <i>WLD</i>		DATE 3/16/78			
FINISH		DESIGNED BY <i>WLD</i>		DATE 3/6/78			
HEAT ASSY USED ON 500036 50117C		MILIT APPR		APPROVED			
SIZE CODE IDENT NO. DWG NO. B 51895 100421		TITLE TERMINAL BOARD DETAIL		SCALE 2/1 97			
SHEET 1 OF 1							

NOTES: UNLESS OTHERWISE SPECIFIED

N-3 Preparation of Gaging Surface

N-589

PROCESS SPECIFICATION
PREPARATION OF GAGING SURFACE

1.0 INTRODUCTION

This general specification is to provide a proper surface and surface finish on which to properly bond semiconductor strain gages.

2.0 REFERENCE DOCUMENTS & EQUIPMENT

350000 - STRAIN GAGE INSTALLATION
SAND BLASTER STATION

300012 - ABRASIVE COMPOUND, PROPRIETARY

3.0 PROCEDURE

3.2 General:

Visually inspect the surface. Gaging areas must be free of any perturbation, pits, risers or contaminants within the material, etc.

3.2 Nozzle Pressure:

Adjust the dry GN₂ regulator pressure to 40 ± 10 psi, using a 1/32 orifice nozzle. Make sure the GN₂ bottle has sufficient reserve pressure. Check the bottle's gage. Change GN₂ bottle if the pressure falls below 75 psi.

3.3 Surface Cleaning:

Clean surface thoroughly using trichloro ethylene by soaking small parts and wiping large parts with soaked cloth. Finish cleaning with pure propyl alcohol or freon FPC.

3.0 PROCEDURE (Continued)

3.4 Using 300012 Material, carefully blast surface by holding nozzle approximately 3.0 inches away and moving nozzle up and back to evenly blast surface to a non-reflective condition which can be seen by no change in color with additional blasting.

Do not blast in one place.

4.0 SPECIFICATION

4.1 No holes or pits greater than 0.0003 over area to be gaged as seen under an X40 microscope.

N-4 Semiconductor Strain Gage Installation Procedure

N-593

PRECEDING PAGE BLANK - NOT FILMED

**SEMICONDUCTOR STRAIN GAGE INSTALLATION
INSTRUCTION FOR USE WITH 6203 ADHESIVE
SPEC. NO. 350001**

1.0 INTRODUCTION

This process specification establishes the procedure for installing of unbacked semiconductor strain gages to all types of transducers and materials which can withstand a cure cycle in a vacuum to +350°F min. for an extended period. The adhesive or epoxy, as referred to in the text, shall be Epoxylite 6203.

2.0 REFERENCE DOCUMENTS

350000 - Process Specification: Preparation of Gaging Surface
350002 - Epoxy Filtering

3.0 NOTES AND PRECAUTION

The 6203 epoxy is a high temperature, extreme range adhesive. It is "stable" to +500°F and will withstand +600°F for a short duration but sustained operation above 250°F, in transducer applications, will result in increased non-repeatability error. However, 6203 has been used as a gage bonding agent on transducers operated at 500°F. The epoxy is a two-part epoxy - Bisphenol A with PMDA as a catalyst. The epoxy contains talc as a filler. The PMDA and talc are mixed together as a fine powder.

3.0 NOTES AND PRECAUTION (Continued)

The Epoxylite 6203 FF premixed and frozen adhesive is ideal for gaging. The talc and catalyst have been ground to a small size (supposedly 0.1 mil) so that lumps are not a big problem, however some larger particles still exist. The date and lot number marked on the tube provide traceability.

The epoxy, as used, is a premixed frozen stick available through *Ablestik, or 6203FF, available in minitubes or in syringes.

3.1 Precaution

3.1.1 Record date of epoxy on traveler folder.

3.1.2 If the color or consistency of the epoxy appears different, notify supervisor.

3.1.3 A separate set of tools shall be used for gaging. (Silicone elastomer and other epoxies will change the bonding characteristics of 6203 epoxy).

3.1.4 The tube of epoxy shall be allowed to warm to room temperature, 60°- 80°F, before opening (15 minutes). Wipe off moisture with Chemwipe before opening.

3.1.5 Adequate control to prevent mixup of new and used tubes is necessary. The common production method is to discard any opened tubes. One of the problems is the picking up of moisture, the other is the gradual

*Ablestik Adhesives Company
833 West 182nd Street
Gardena, California 90248
(213) 321-6252

3.0 NOTES AND PRECAUTIONS (Continued)

hardening of the 6203 (partial cure) so that it is no longer workable.

Under extremely high humidity conditions, gaging should not be done because of the absorption of water from the air by the epoxy. A small soldering iron such as the ORYX 12-6 should be used. A control box for setting the voltage is necessary. It is best to do soldering with the sensor (transducer) on a hot plate at about 200°F, but not mandatory. Normally, the same heating arrangement is used for both gaging and soldering, although these are done at separate times. Soldering to the gold wire is usually done last; that is, after the extension wires have been soldered to the tabs. This minimizes the time (or times) the gold wire-solder joint gets heated.

It is difficult to replace a single gage (or less than all gages) after the transducer is connected up. Often the transducer is given a 48-hour cure at 250°F instead of the prescribed 24 hours at 250°F and 24 hours at 350°F to save the connections. This is more critical on diffused gages where the wire is smaller.

A special mini-hot plate has been designed for use under a microscope. It is ideal for gaging and soldering.

3.0 NOTES AND PRECAUTIONS (Continued)

Pot life for the epoxy shall be designated as 3 hours, i.e., any defrosted epoxy shall be considered unusable for gaging after 3 hours at room temperature. DO NOT REPLACE opened tube in freezer regardless of period that it was at room temperature.

3.1.6 Do not use glass tape in curing oven, (due to outgassing).

4.0 EQUIPMENT

- 4.1 Tweezers
- 4.2 Sand Blaster, SS White No. 9 or equivalent
- 4.3 Vacuum Oven
- 4.4 Petri Dish
- 4.5 Transducer Body and Beam Holders
- 4.6 Deleted - Per Revision A
- 4.7 Hot Plate, Miniature
- 4.8 Microscope, AO, or equivalent 10X Stereo
- 4.9 X-Acto Knife
- 4.10 Megohm Meter, 50V Maximum
- 4.11 No. 000 Brush
- 4.12 Spatula
- 4.13 Dental Pick

5.0 SURFACE PREPARATION

5.1 Sandblast surfaces to be gaged per process specification.

5.0 SURFACE PREPARATION (Continued)

5.2 Chemically clean transducer to be gaged.

5.3 If the transducer to be gaged cannot be used immediately, store in a vacuum chamber.

6.0 BASE COAT APPLICATION (NOTE: This work to be done under plastic cover)

The base coat is needed to provide electrical insulation between the gage and the bonding surface.

6.1 Set the hot plate at 110°F to 200°F.

6.2 Place part to be gaged on hot plate. Use holder as necessary. With large instruments, heat in oven at 150°F ± 40°F, for 1.0 to ± 0.5 hours prior to placing on the hot plate.

6.3 Filter epoxy through proprietary screen filter.

6.3.1 Apply a thin coat of filtered epoxy on the surface to be gaged with the No. 000 brush.

All epoxy hereto referred to will be screened.

6.4 Brush the epoxy to an even coat. NOTE: Avoid excessive brushing, (ref. dimension of base coat approximately 0.7 mils but less than 1.0 mil).

6.5 Repeat 6.3 and 6.4 for all other surfaces to be gaged.

6.6 Cure base coat for 60 minutes ± 15 minutes at +250°F ± 10°F.

6.7 If the base coated transducers cannot be gaged within

6.0 BASE COAT APPLICATION (Continued)

8 hours, store them in a vacuum chamber at ambient temperature.

7.0 GAGE PREPARATION

In general, the gages used for transducers are matched in sets. The gages are identified as 1, 2, 3, 4, etc. The gage identities should be kept and the gages laid at the positions indicated on the transducer drawing.

7.1 Record the gage data.

7.2 Cut gage leads at label in boxes.

7.3 Pick up gage with tweezers by one lead approximately 1/32 inch from the element.

7.4 Straighten this lead wire.

7.5 Repeat steps 7.3 and 7.4 for other lead wires. Keep gage identity.

7.6 Trim lead with X-Acto Knife to a maximum length of 1/2 inch.

7.7 Bend the leads 90° to the top surface of the sensor.

The lead wires should be normal to the top surface of the sensor, starting 1/32 inch from the element.

Where the gages are located extra close to a wall or other obstacle, the wire should be formed such that it is curved away from the obstacle before the lead, or leads are formed normal to the gage surface.

7.0 GAGE PREPARATION (Continued)

7.8 Repeat steps 7.3 through 7.7 for other gages in set.

7.9 Soak the gages in acetone for 1 minute.

7.10 Dry on the hot plate at $200^{\circ}\text{F} \pm 50^{\circ}\text{F}$.

7.11 Return to its plastic box.

7.12 Attach recorded data to the appropriate shop traveler.

8.0 GAGE INSTALLATION (This Work To Be Done Under Plastic Cover)

Gages are to be installed only in bumpless blemish-free areas perfectly flat with even precoat.

8.1 Place the part to be gaged on a hot plate, set at $155^{\circ}\text{F} \pm 45^{\circ}\text{F}$. Where the part requires a holding fixture, mount part on the fixture before placing part and fixture on the hot plate.

8.2 Pick a gage and determine from the transducer drawing the exact location of that gage. Start with Step 8.1 when more than one surface is to be gaged.

8.3 Pick up the gage by one of its leads with the tweezers as close as possible to the silicon gage without touching it.

8.4 Wet the bottom of the gage by dragging the gage over the filtered epoxy .0005 to .0010 thick.

8.5 Place the gage at the proper location on the body or beam.

8.0 GAGE INSTALLATION (Continued)

- 8.6 Orient the gages as necessary to conform to drawing.
- 8.7 Check to ensure that all sections of the gage are in contact with the surface.
- 8.8 Where the end of the compression gages are mounted closer than 0.010" from the transducer wall, a coat of epoxy will be applied to the wall to prevent the gage lead wire from shorting to case.
- 8.9 Repeat Steps 8.2 through 8.7 for other gages.
- 8.10 On some designs where more than one surface is to be gaged, and only one surface can be gaged at a time, the following sequence of gaging shall be used:
- 8.10.1 Base coat all gaging surfaces.
- 8.10.2 Gage one surface at a time per Step 8.2 through 8.9.
- 8.10.3 Repeat Step 8.10.2 for all surfaces.
- 8.11 Apply a coat of epoxy to all uncoated surfaces over which the gage wire will be routed and to the area where the solder tabs are to be located.
- 8.12 Cure gaged body or beams at $200^{\circ}\text{F} \pm 10^{\circ}\text{F}$ for 24 ± 4 hours in vacuum oven, then raise to $250^{\circ}\text{F} \pm 10^{\circ}\text{F}$ for 24 ± 4 hours, then raise to $300^{\circ}\text{F} \pm 10^{\circ}\text{F}$ for 24 ± 4 hours, and final cure to $350^{\circ}\text{F} \pm 10^{\circ}\text{F}$ for 24 ± 4 hours.

8.0 GAGE INSTALLATION (Continued)

NOTE: It is possible to circulate vacuum pump oil back into the vacuum oven. The following steps will be used in pumping down and opening ovens.

A. Pump Down

1. Close Door.
2. Close relief valve.
3. Leak air into vacuum pump by very slowly opening pumping valve. Minimum time (full valve opening) approximately 3-5 minutes.
4. Pump should never be turned off.

B. Opening Oven

1. Turn valve off.
2. Open relief valve.
3. Open door and remove part.
4. Close door and evacuate oven when not in use.

9.0 TERMINAL RINGS AND/OR TABS MOUNTING

9.1 Apply a small amount of 6203 epoxy on the areas to which the ring or tabs are to be mounted. Screened epoxy not required here.

9.2 Position ring or tabs.

9.3 Cure for 2 hours \pm 30 minutes at $250^{\circ}\text{F} \pm 10^{\circ}\text{F}$.

10.0 LEAD WIRE

- 10.1 Form the leads to the ring or tabs as shown in their applicable drawings.
- 10.2 Solder the leads to tabs or ring.
- 10.3 Tack down gage lead to base coated areas, with unscreened 6203 epoxy.
- 10.4 Cure for 2 hours \pm 30 minutes at 250°F.
- 10.5 Make insulation resistance and continuity tests.
The insulation resistance of the bridge to case ground shall be greater than 50 megohms at 50V D.C. If below 50 megohms chemically clean area, bake out and recheck. If resistance still below 50 megohms, remove all gages by sandblasting and repeat entire procedure.

11.0 INSPECTION

- 11.1 Base coat shall be uniform over the area immediately around the sensors.
- 11.2 Gaging shall be checked for an epoxy coat on the wall of the transducer where the end of the compression gages are mounted closer than 0.010" from the wall.
- 11.3 All gages shall have a fillet formed by epoxy around the ends of each gage.
- 11.4 Gages shall be checked for proper orientation per applicable drawing.

11.0 INSPECTION (Continued)

- 11.5 Check the shop traveler for epoxy date, gage and insulation resistance data per Paragraph 10.5.
- 11.6 No top coat or over coat shall be permitted on the top side of the gages. Spots of epoxy shall be permissible. Where the size and extent of the epoxy spot is in question, the criteria for acceptance and rejection shall be determined by the precal test data on repeatability of unit.

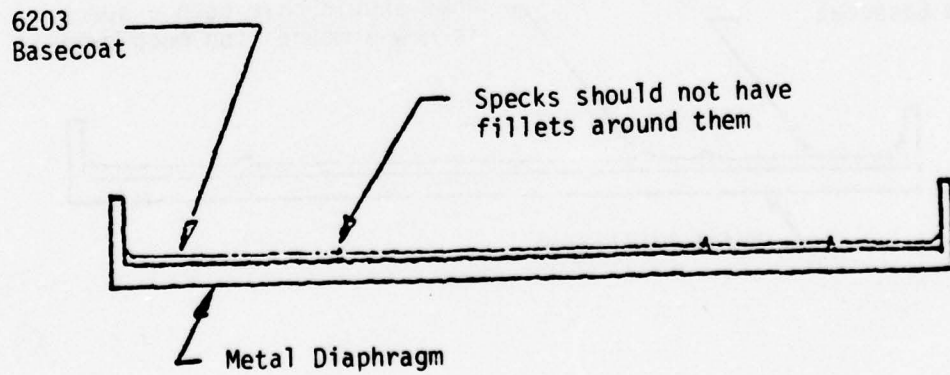
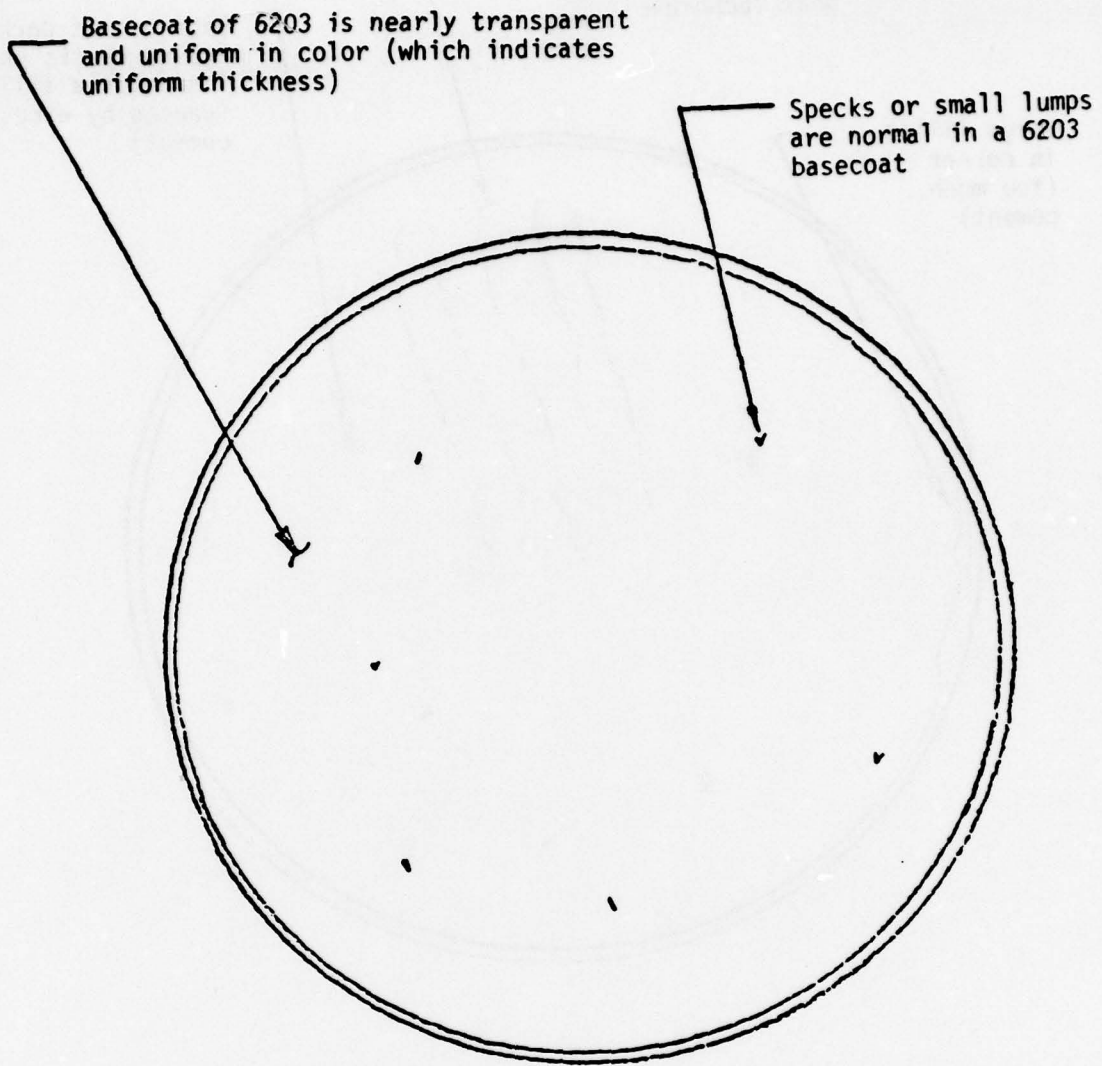

Figure 4.1. Typical Good Basecoat

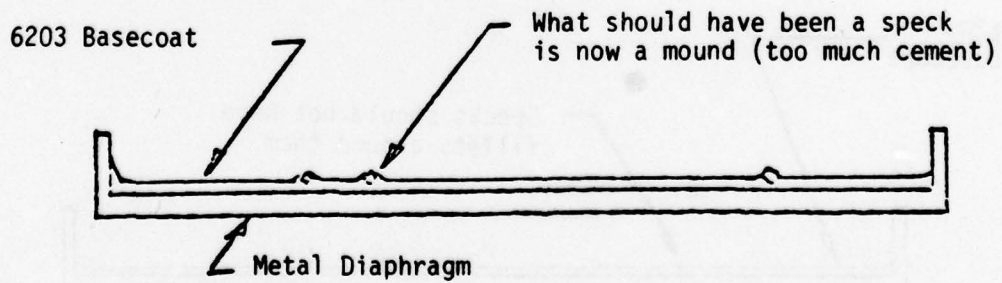
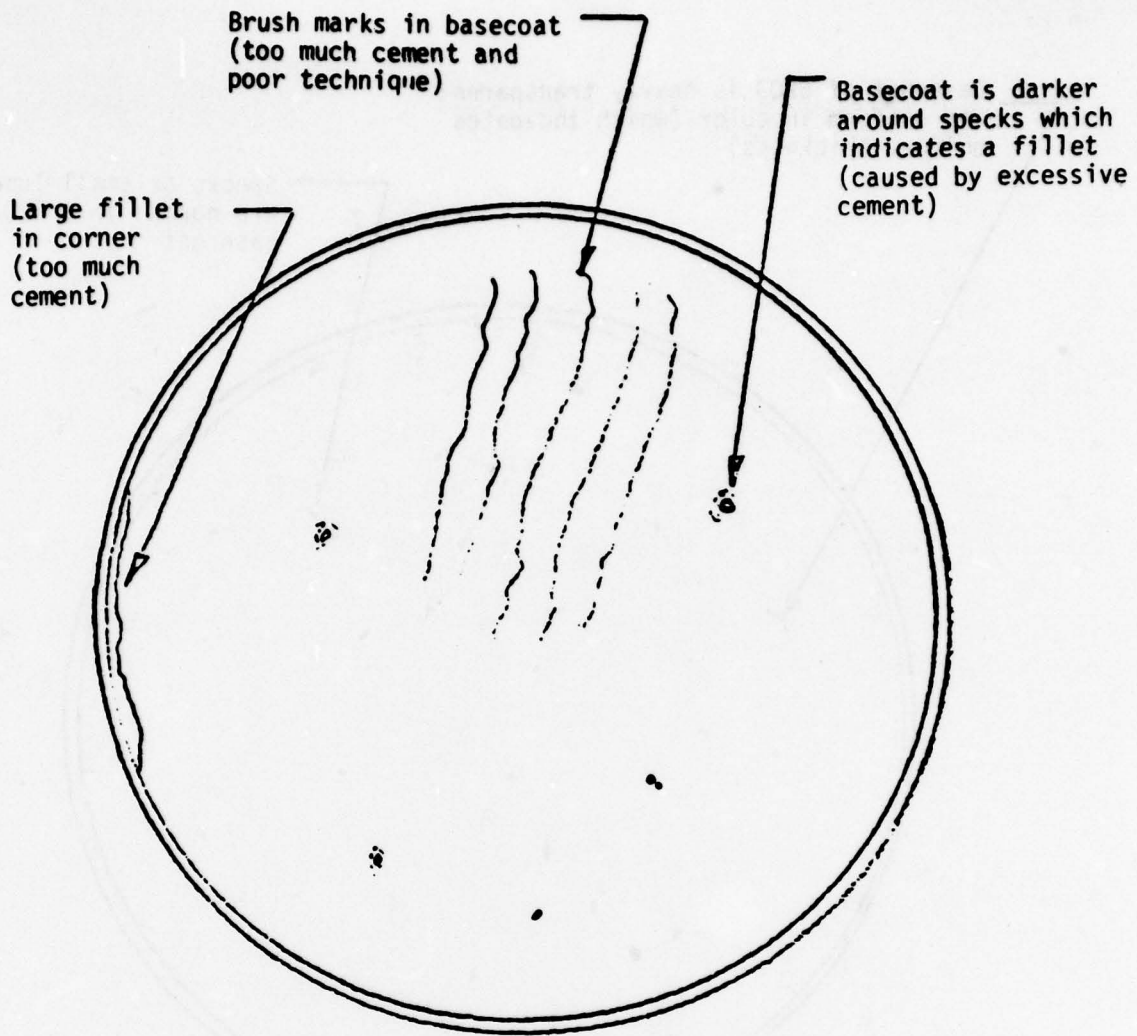

Figure 4.2. Typical Bad Basecoat

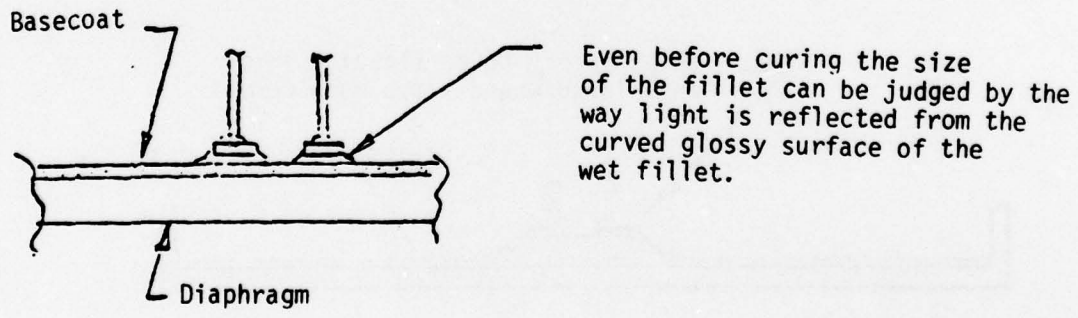
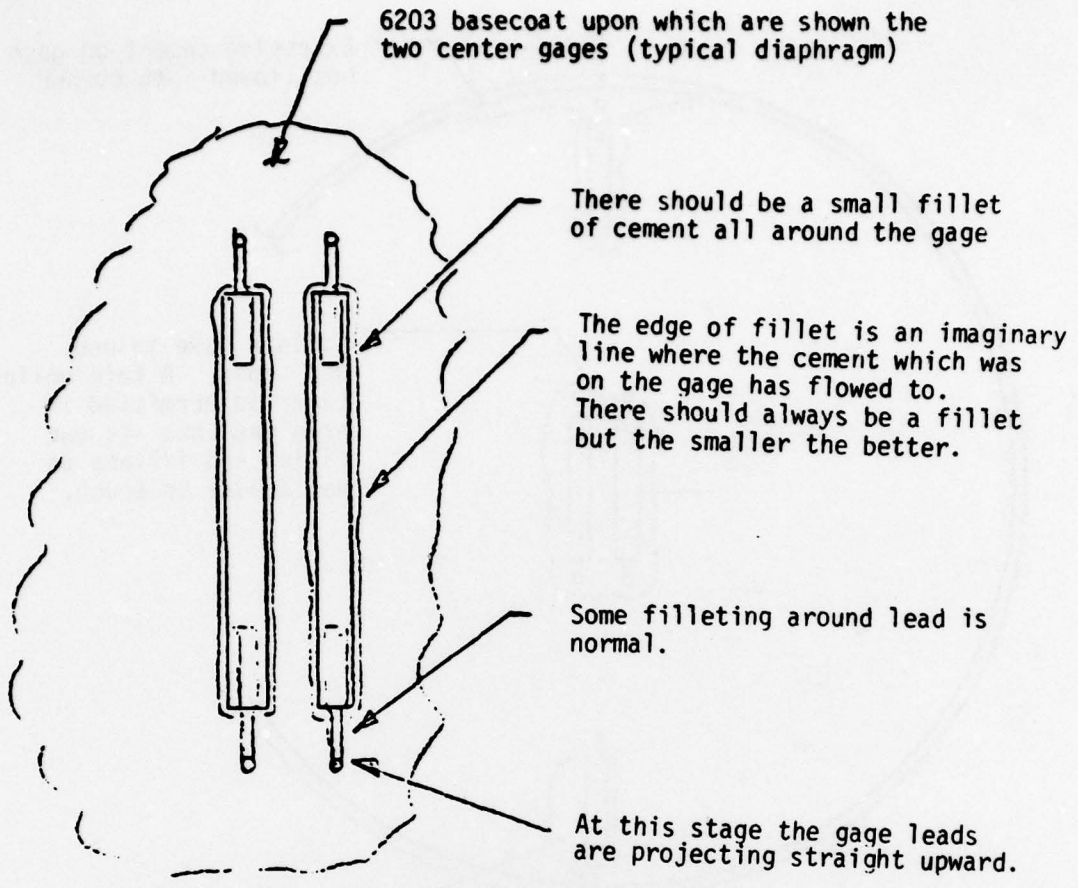

Figure 4.3. Good Gage Cementing

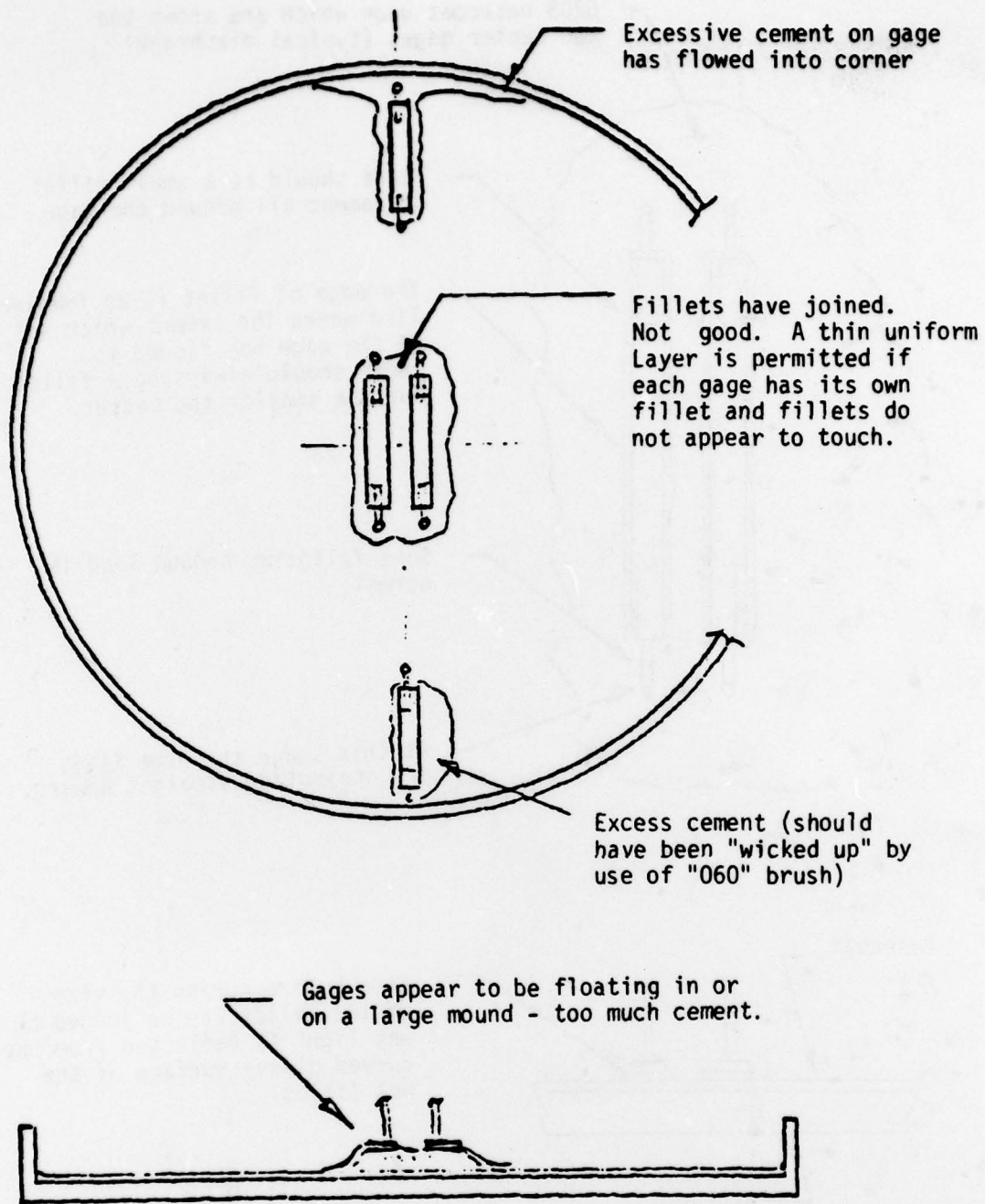

Figure 4.4. Bad Gage Cementing

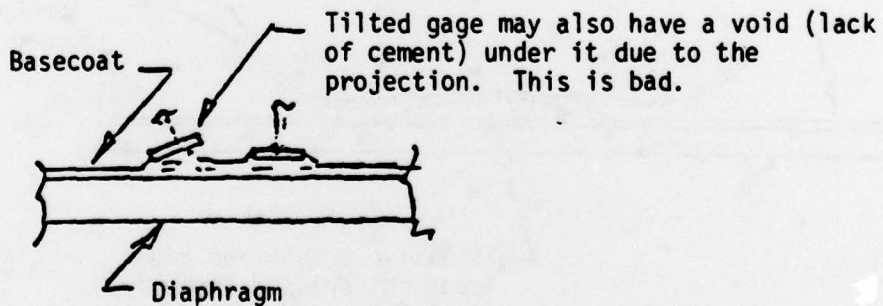
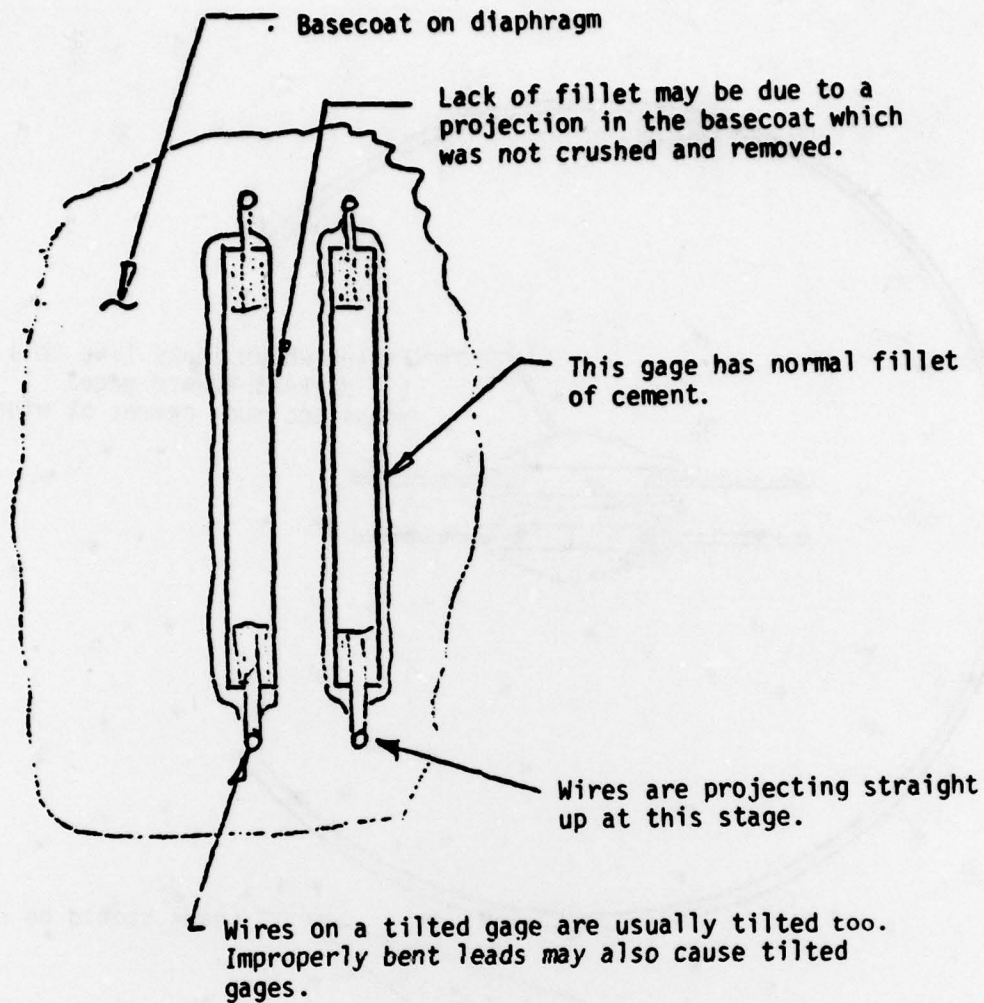

Figure 4.5. A Tilted Gage (Bad)

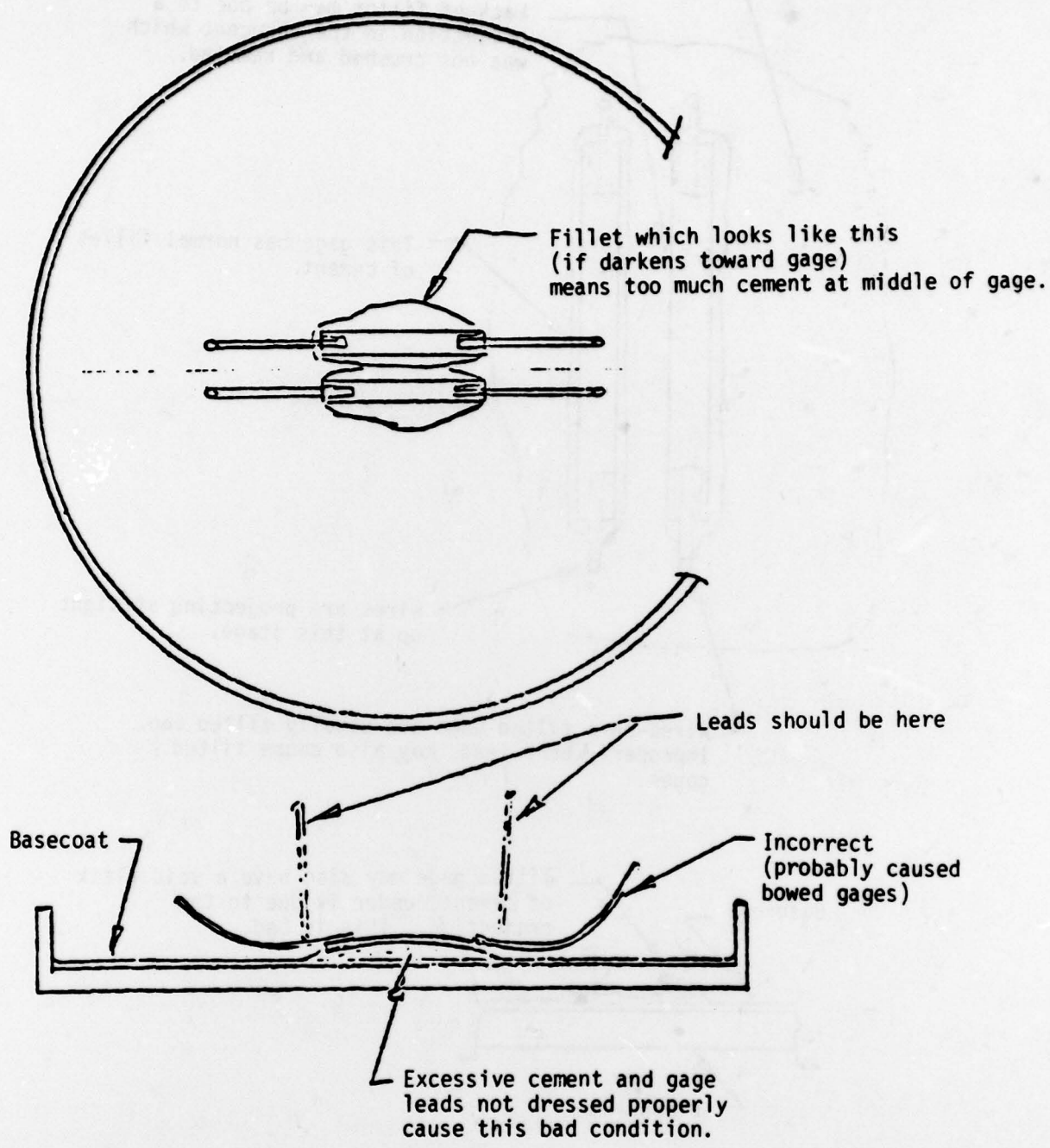

Figure 4.6. Bowed Gages (Bad)

N-5 Epoxy Filtering Procedure

EPOXY FILTERING

1.0 INTRODUCTION

This process is to remove any conglomerates from the epoxy in order to optimize performance and minimize creep.

2.0 EQUIPMENT

Reference: Document 350001 for Equipment

Screen - Proprietary - SMI #400038

3.0 PROCEDURE

3.1 Heat epoxy - See Addendum Para. 3.1.4 of 350001.

Obtain pre-mixed pre-frozen epoxy from freezer. Allow to thaw Per 350001. Put screen on top of spatula on top of hot plate. Set between 150^o- 200^oF. Squeeze epoxy on top of filter.

3.2 Screen epoxy

Allow epoxy to flow onto spatula below screen. Epoxy on spatula is now ready for pre-coating and gaging. Bottom of screen may be scraped with clean spatula or flat of pick for more filtered epoxy.

4.0 SPECIFICATION

No particles greater than .0005.

5.0 POT LIFE

See 350001.

N-6 15-5 Stainless Steel Metal Conditioning Process

N-613

TABLE II

COMPLETE STRESS RELIEF METAL CONDITIONING PROCESS

- I. Machine transducer hardware from condition A 15-5 stainless steel.
- II. After machining is complete:
 - (a) Heat treat to $1900^{\circ}\text{F} \pm 25^{\circ}\text{F}$ in argon atmosphere for $\frac{1}{2}$ hour. Cool from 1900°F to 800°F in 15 minutes \pm 10 minutes, and same rate to 70°F .
 - (b) Cold soak samples to -100°F for 1 hour within 24 hours after air cooling to 70°F . Place hardware in bucket or other container in -100°F environment rather than placing hardware directly into -100°F solution. This will prevent excessive thermal stresses (exceeding precision elastic limit) during cooldown process. The 15-5 alloy is martensite at 70°F but may have minute amounts of metastable austenite. Dropping to -100°F or lower assures complete transformation to martensite. Air warm samples to 70°F at rate of $100^{\circ}\text{F}/\text{hr}$ or less.
 - (c) Precipitation harden material at $900^{\circ}\text{F} \pm 25^{\circ}\text{F}$ for 1 hour. Air cool to 70°F at rate of $100^{\circ}\text{F}/\text{hr}$ or less.
 - (d) Descale hardware with grit blast procedure to remove discoloration (oxidation) and activate surface for bonding semi-conductor strain gages.

SIZE	CODE IDENT NO.	DWG NO.	REV.
A	51895	350003	--
SCALE	WT	SHEET	

N-7 Technical Specification for Homogenous
Semiconductor Strain Gages

N-615

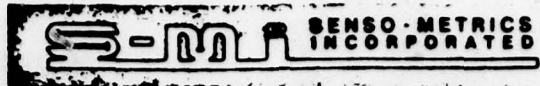

SENSING SYSTEMS & MEASUREMENTS

TECHNICAL SPECIFICATION FOR
 HOMOGENEOUS SEMICONDUCTOR STRAIN GAGE
 SMI-04-022-500P (Commercial) SMI-04-022-500P M (Military)
 (Considered for use in future reduced size transducer)

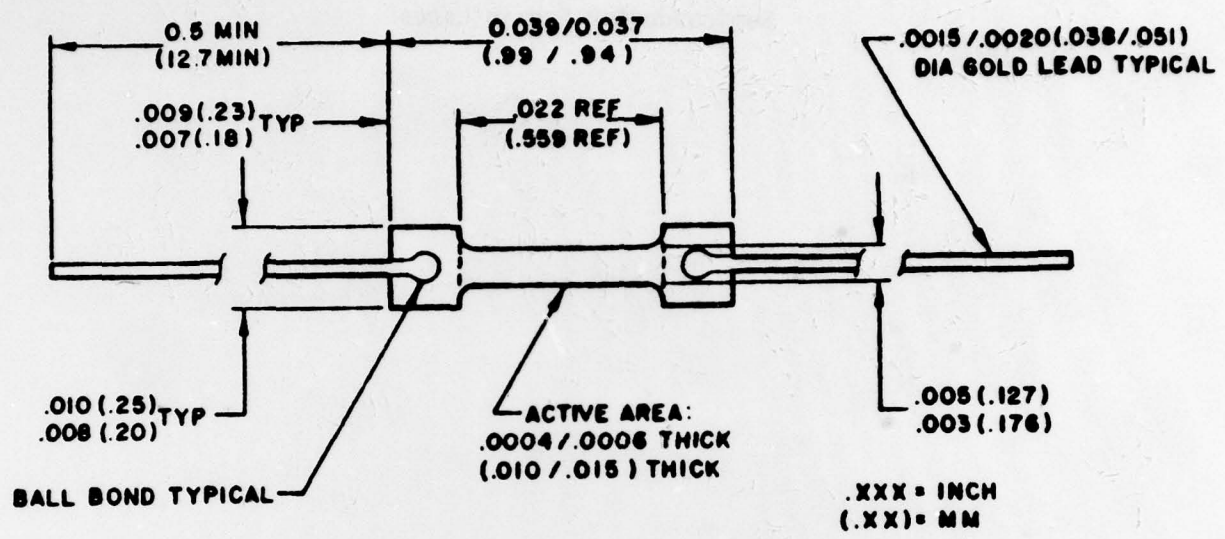

1.0 GENERAL

This semiconductor strain gage is made from P-doped bulk silicon. It has no semiconductor P/N junction. The silicon is etched to shape eliminating the potential for molecular dislocation or cracks thereby optimizing performance.

2.0 SPECIFICATIONS: INDIVIDUAL GAGES

- 2.1 Material P 111 Czochralski pulled boron doped Silicon .05 Ohm/CM.
- 2.2 Resistance 525 ± 50 unbonded at 70°F
- 2.3 Average Gage Factor. 140 ± 10
- 2.4 Thickness (Active Area).0005 inch max.
- 2.5 Leads.002 dia. Gold x 0.5 inch min.
- 2.6 Contact. Silicon/Gold or Gold Nick. Fused.
- 2.7 Attachment Ball Bond

3.0 STANDARD BRIDGE MATCHING

- 3.1a Temperatures °F 0, 78, 278 Standard
- 3.1b Temperatures °F -65, 0, 78, 278. Military
- 3.2a Resistance Tolerance Ohms $\pm 2\%$ max. at each temp. Standard
- 3.2b Standard Sets of 4 ea. $\pm 1\%$ max. at each temp. Military

PRICING
HOMOGENEOUS SEMICONDUCTOR STRAIN GAGE
SMI-04-022-300

NOMENCLATURE:

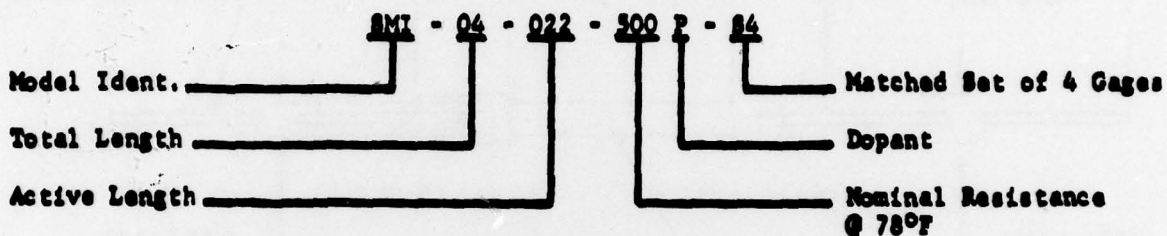

GAGE AVAILABILITY

- SMI-04-022-300P Individual Commercial Gages
- SMI-04-022-300P M Individual Military Gages
- SMI-04-022-300P-84 Sets of 4 matched (Comm) gages per 3.1a & 3.2a
- SMI-04-022-300P M-84 Sets of 4 matched (Mill) gages per 3.2b & 3.2b

QUANTITY	Individual Gage		Matched Sets	
	300P Gage	300PM Gage	300P-84 Sets	300PM-84 Sets
1 - 4	\$12.00	\$16.00	\$55.00	\$80.00
5 - 9	11.00	14.00	45.00	68.00
10 - 24	9.00	12.00	40.00	56.00
25 - 49	6.00	10.00	30.00	46.00
50 - 99	5.00	8.00	22.00	40.00



SENSING SYSTEMS & MEASUREMENTS

TECHNICAL SPECIFICATION FOR
 HOMOGENEOUS SEMICONDUCTOR STRAIN GAGE
 SMI-06-033-500P (Commercial) SMI-06-033-500P M (Military)

(Used in final low profile transducer)

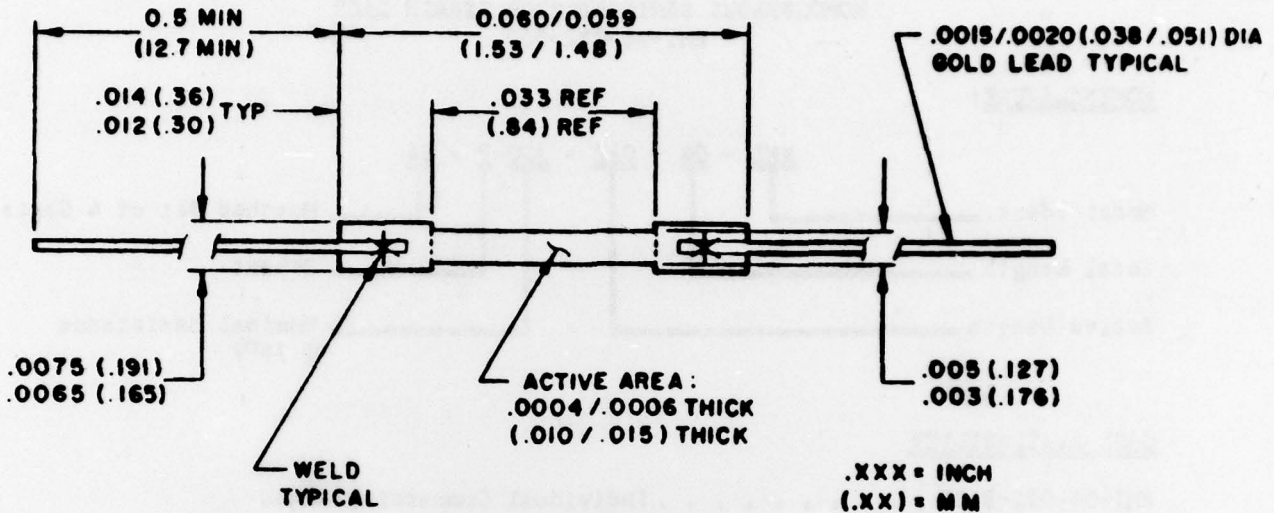

1.0 GENERAL

This semiconductor strain gage is made from P-doped bulk silicon. It has no semiconductor P/N junction. The silicon is etched to shape eliminating the potential for molecular dislocation or cracks thereby optimizing performance.

2.0 SPECIFICATIONS: INDIVIDUAL GAGES

- 2.1 Material P 111 Czochralski pulled boron doped Silicon .05 Ohm/CM.
- 2.2 Resistance 525 ± 50 unbonded at 70°F
- 2.3 Average Gage Factor. 140 ± 10
- 2.4 Thickness (Active Area)0005 inch max.
- 2.5 Leads002 dia. Gold x 0.5 inch min.
- 2.6 Contact. Silicon/Gold or Gold Nick. Fused.
- 2.7 Attachment Parallel Gap welded Gold leads with epoxy reinforcement

3.0 STANDARD BRIDGE MATCHING

- 3.1a Temperatures °F 0, 78, 278 Standard
- 3.1b Temperatures °F -65, 0, 78, 278 Military
- 3.2a Resistance Tolerance Ohms $\pm 2\%$ max. at each temp. Standard
- 3.2b Standard Sets of 4 ea. $\pm 1\%$ max. at each temp. Military

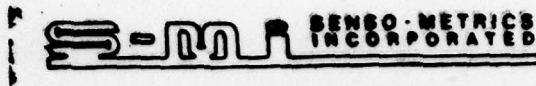

SENSING SYSTEMS & MEASUREMENTS

TECHNICAL SPECIFICATION FOR
 HOMOGENEOUS SEMICONDUCTOR STRAIN GAGE
 SMI-08-050-500P (Commercial) SMI-08-050-500P M (Military)
 (Used in Prototype Transducers)

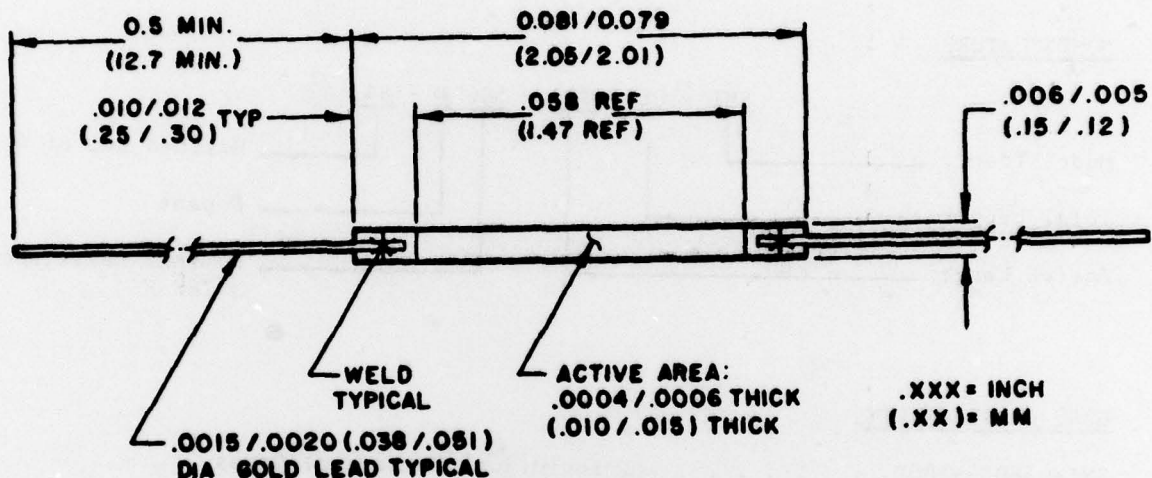

1.0 GENERAL

This semiconductor strain gage is made from P-doped bulk silicon. It has no semiconductor P/N junction. The silicon is etched to shape eliminating the potential for molecular dislocation or cracks thereby optimizing performance.

2.0 SPECIFICATIONS: INDIVIDUAL GAGES

2.1 Material	P 111 Czochralski pulled boron doped Silicon .05 Ohm/CM.
2.2 Resistance	525 ± 50 unbonded at 70°F
2.3 Average Gage Factor	140 ± 10
2.4 Thickness (Active Area)0005 inch max.
2.5 Leads002 dia. Gold x 0.5 inch min.
2.6 Contact	Silicon/Gold or Gold Nick. Fused
2.7 Attachment	Parallel Gap welded Gold Leads with epoxy reinforcement.

3.0 STANDARD BRIDGE MATCHING

3.1a Temperatures °F	0, 78, 278	Standard
3.1b Temperatures °F	-65 0, 78, 278	Military
3.2a Resistance Tolerance Ohms	± 2% max. at each temp.	Standard
3.2b Standard Sets of 4 ea.	± 1% max. at each temp.	Military

**PRICING
HOMOGENEOUS SEMICONDUCTOR STRAIN GAGE
SMI-08-050-500**

NOMENCLATURE:

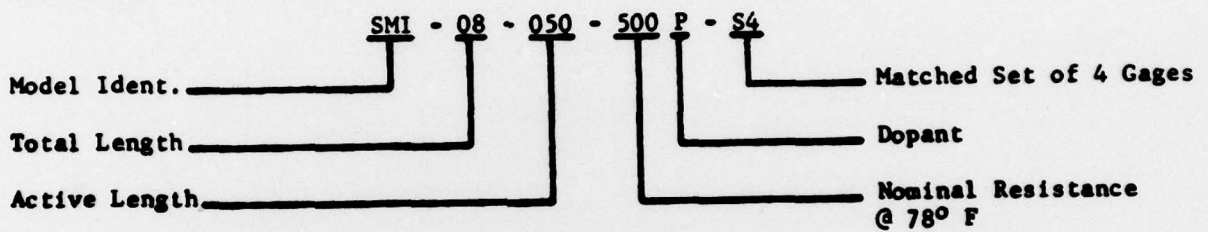

GAGE AVAILABILITY

- SMI-08-050-500P Individual Commercial Gages
- SMI-08-050-500P M Individual Military Gages
- SMI-08-050-500P-S4 Sets of 4 matched (Comm) gages per 3.1a & 3.2a
- SMI-08-050-500P M-S4 Sets of 4 matched (Mili) gages per 3.1b & 3.2b

QUANTITY	<u>Individual Gage</u>		<u>Matched Sets</u>	
	500P Gage	500PM Gage	500P-S4 Sets	500PM-S4 Sets
1 - 4	\$8.00	\$14.00	\$40.00	\$72.00
5 - 9	7.00	12.00	36.00	62.00
10 - 24	6.00	10.00	30.00	52.00
25 - 49	5.00	8.00	26.00	43.00
50 - 99	4.00	6.00	20.00	34.00