

AD-A073 802

CONSTRUCTION ENGINEERING RESEARCH LAB (ARMY) CHAMPAIGN IL F/G 13/2
PROBABILISTIC CONCEPT FOR GRAVITY DAM ANALYSIS.(U)
AUG 79 J D PRENDERGAST

UNCLASSIFIED

CERL-SR-M-265

NL

| OF |

AD
A073 802



END
DATE
FILMED
10-79
DDC

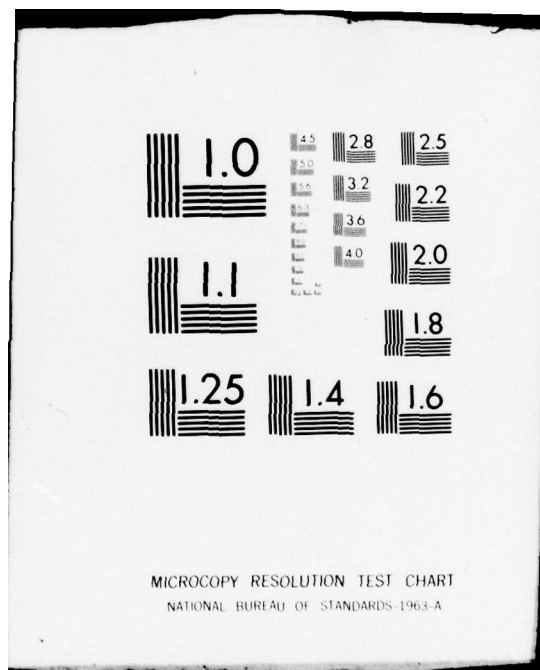

MICROCOPY RESOLUTION TEST CHART
NATIONAL BUREAU OF STANDARDS-1963-A

construction
engineering
research
laboratory

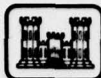

United States Army
Corps of Engineers
... Serving the Army
... Serving the Nation

SPECIAL REPORT M-265
August 1979

12 P.S.

PROBABILISTIC CONCEPT
FOR GRAVITY DAM ANALYSIS

A 073802

DDG FILE COPY

LEVEL IV

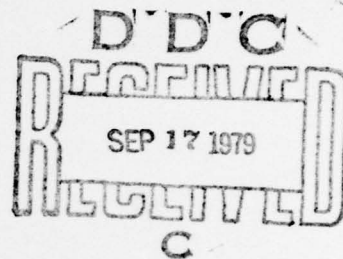

by
James D. Prendergast

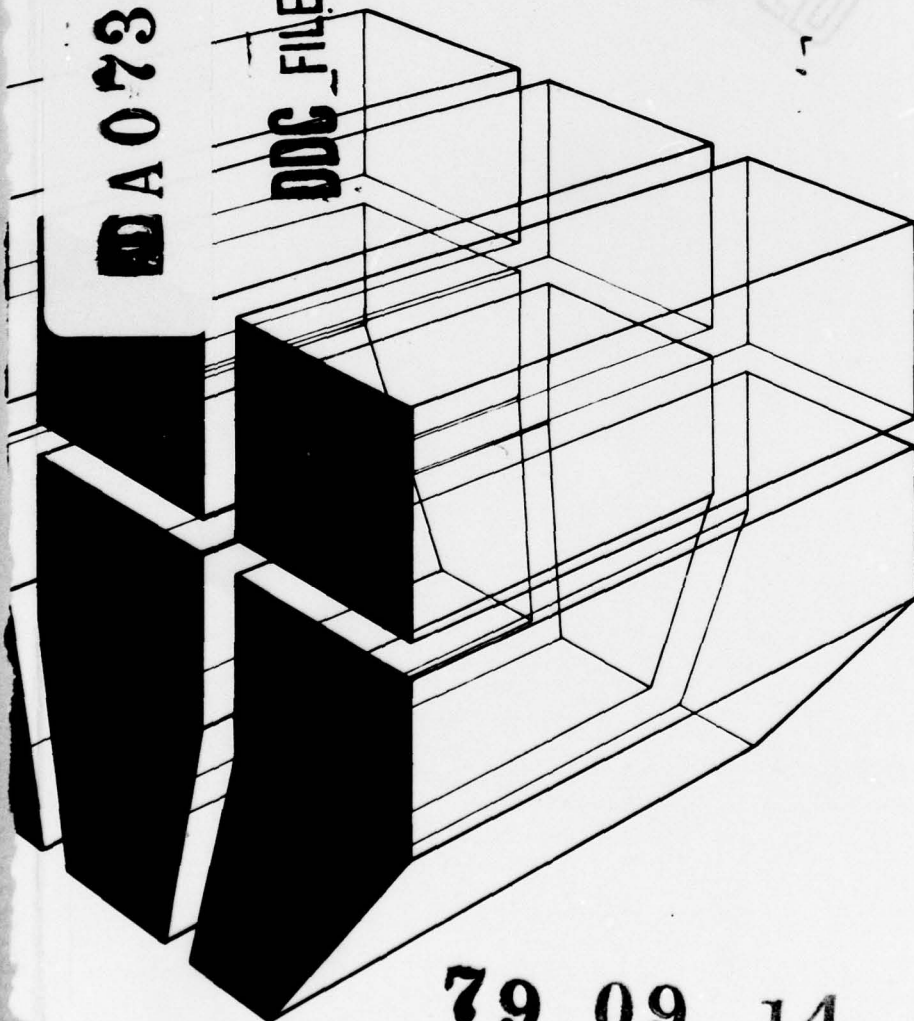

79 09 14 058



Approved for public release; distribution unlimited.

The contents of this report are not to be used for advertising, publication, or promotional purposes. Citation of trade names does not constitute an official indorsement or approval of the use of such commercial products. The findings of this report are not to be construed as an official Department of the Army position, unless so designated by other authorized documents.

**DESTROY THIS REPORT WHEN IT IS NO LONGER NEEDED
DO NOT RETURN IT TO THE ORIGINATOR**

REPORT DOCUMENTATION PAGE		READ INSTRUCTIONS BEFORE COMPLETING FORM
1. REPORT NUMBER 14 CERL-SR-M-265	2. GOVT ACCESSION NO.	3. RECIPIENT'S CATALOG NUMBER 9
4. TITLE (and Subtitle) 6 PROBABILISTIC CONCEPT FOR GRAVITY DAM ANALYSIS	5. TYPE OF REPORT & PERIOD COVERED SPECIAL / <i>rept.</i>	
	6. PERFORMING ORG. REPORT NUMBER	
7. AUTHOR(s) 10 James D. Prendergast	8. CONTRACT OR GRANT NUMBER(s)	
9. PERFORMING ORGANIZATION NAME AND ADDRESS U.S. ARMY CONSTRUCTION ENGINEERING RESEARCH LABORATORY P.O. Box 4005, Champaign, IL 61820	16	10. PROGRAM ELEMENT, PROJECT, TASK AREA & WORK UNIT NUMBERS 4A761101A91D
11. CONTROLLING OFFICE NAME AND ADDRESS	11	12. REPORT DATE August 1979
14. MONITORING AGENCY NAME & ADDRESS (if different from Controlling Office) 12 70p.	13. NUMBER OF PAGES 68	
	15. SECURITY CLASS. (of this report) Unclassified	
15a. DECLASSIFICATION/DOWNGRADING SCHEDULE		
16. DISTRIBUTION STATEMENT (of this Report) Approved for public release; distribution unlimited. 11		
17. DISTRIBUTION STATEMENT (of the abstract entered in Block 20, if different from Report)		
18. SUPPLEMENTARY NOTES Copies are obtainable from National Technical Information Service Springfield, VA 22151		
19. KEY WORDS (Continue on reverse side if necessary and identify by block number) dam safety gravity dams probability		
20. ABSTRACT (Continue on reverse side if necessary and identify by block number) This report describes a probabilistic concept for evaluating the safety of concrete gravity dams against sliding and overturning failures in terms of the various sources of uncertainty underlying the design parameters. This concept is used to compute the probability of sliding and overturning failures of two moderately low nonoverflow gravity dams designed using conventional design procedures for reservoir water loadings, and in one instance, earthquake loadings. The results show that it is possible to quantify the safety of a dam in a probabilistic sense.		

SECURITY CLASSIFICATION OF THIS PAGE(When Data Entered)

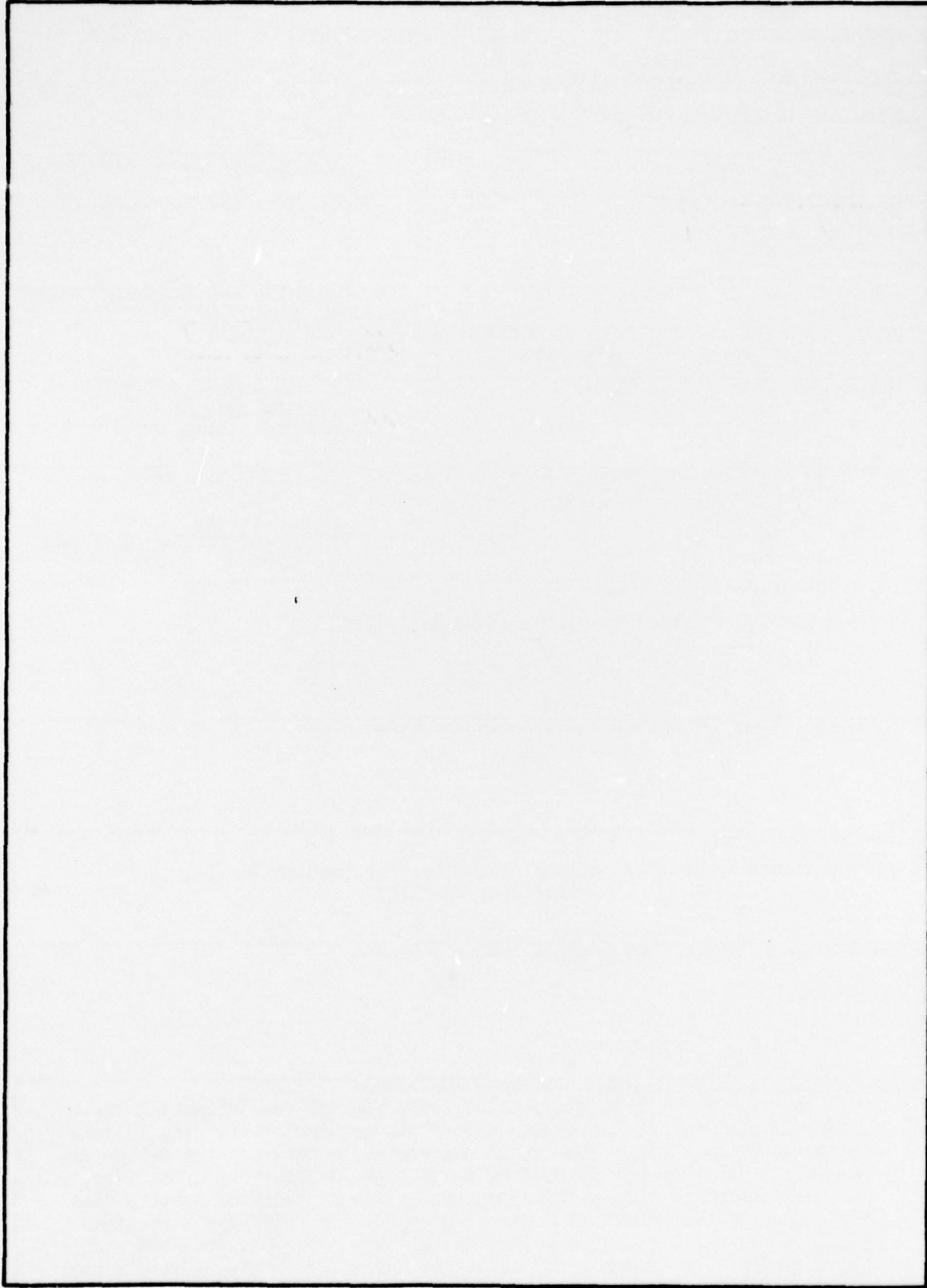

SECURITY CLASSIFICATION OF THIS PAGE(When Data Entered)

FOREWORD

This investigation was performed for the Commander and Director, U.S. Army Construction Engineering Research Laboratory (CERL) under Project 4A761101A91D, In-House Laboratory Independent Research Program.

This investigation was performed by the Engineering and Materials Division (EM), CERL, under the direction of Dr. J. D. Prendergast, Principal Investigator, with technical advice and support from Dr. W. E. Fisher, Chief of Engineering Team of EM; Prof. A. H. S. Ang, University of Illinois, Urbana; and Dr. L. R. Shaffer, Technical Director, CERL.

Dr. G. R. Williamson is Chief of EM and COL J. E. Hays is Commander and Director of CERL.

Accession For	
NTIS GNA&I	<input checked="" type="checkbox"/>
DDC TAB	<input type="checkbox"/>
Unannounced	<input type="checkbox"/>
Justification	
By _____	
Distribution/	
Availability Codes	
Dist	Avail and/or special
A	

CONTENTS

	<u>Page</u>
DD FORM 1473	1
FOREWORD	3
LIST OF TABLES AND FIGURES	
1 INTRODUCTION.....	7
Problem	
Objective	
Scope	
2 CONCRETE GRAVITY DAMS.....	11
General	
Design Forces	
Failure Mechanisms	
Loading Conditions	
Stability Requirements	
Sliding and Overturning Criteria	
Shear Friction Factor of Safety	
Analysis Method	
Forces and Moments	
3 RELIABILITY THEORY.....	24
General	
Extended Reliability Theory	
Distribution Function	
4 PROBABILISTIC LOAD AND RESISTANCE MODELS.....	28
General	
Horizontal Force Model	
Sliding Resistance Model	
Foundation Pressure Model	
Foundation Compressive Strength Model	
5 SIMPLE APPLICATIONS.....	47
General	
200-Ft Nonoverflow Gravity Dam	
200-Ft Nonoverflow Gravity Dam With Earthquake Loading	
6 PRELIMINARY CONCLUSIONS AND RECOMMENDATIONS.....	62
Conclusions	
Recommendations	
REFERENCES	64
APPENDIX	65

TABLES

<u>Number</u>		<u>Page</u>
1	Dams for Which the Corps Has Full Responsibility	8
2	Limits for the Location of the Resultant and Maximum Sliding Factor	20
3	Maximum and Residual Angles of Internal Friction	41
4	Mean and Coefficient of Variation of N_j Corresponding to Different Distributions Assumed Over Its Range	49
5	Mean and Coefficient at Variation for Random Variables and Their Corrective Factors	51
6	Mean and Coefficient of Variations for Random Variables and Their Corrective Factors	55

FIGURES

1	General Profile of Nonoverflow Section of a Gravity Dam	12
2	Distribution of Internal Hydrostatic Pressure	13
3	Value of Earthquake Factor C	15
4	Forces Acting on Nonoverflow Section of Gravity Dam	19
5	Seismic Zone Map for Contiguous States	31
6	Seismic Zone Map for Alaska	32
7	Seismic Zone Map for Hawaii	33
8	Contour Map of Effective Peak Acceleration (EPA) for 48 Contiguous States	35
9	Contour Map of Effective Peak Velocity-Related Acceleration (EPV) for 48 Contiguous States	36
10	Shear Strength Versus Horizontal Displacement Showing Maximum and Residual Stresses	40
11	Maximum Strength and Residual Failure Envelope for Initially Intact Specimens	40

FIGURES (Cont'd)

<u>Number</u>	<u>Page</u>
12 Foundation Pressure Measurements Under Shasta Dam	45
13 Foundation Pressure Measurements Under Grand Coulee Dam	45
14 200-Ft Nonoverflow Gravity Dam	48
15 Probability of Overturning Failure vs. Reservoir Water Elevation Corrective Factor	52
16 Probability of Overturning Failure vs. Hydrostatic Pressure Intensity Corrective Factor	52
17 Probability of Overturning Failure vs. Foundation Compressive Strength Corrective Factor	52
18 200-Ft Nonoverflow Gravity Dam With Earthquake Loading	54
19 Probability of Sliding Failure vs. Earthquake Acceleration Coefficient Corrective Factor	56
20 Probability of Sliding Failure vs. Foundation Shear Strength Corrective Factor	56
21 Probability of Overturning Failure vs. Reservoir Water Elevation Corrective Factor	57
22 Probability of Overturning Failure vs. Earthquake Acceleration Coefficient Corrective Factor	57
23 Probability of Overturning Failure vs. Earthquake Factor Corrective Factor	58
24 Probability of Overturning Failure vs. Hydrostatic Pressure Intensity Corrective Factor	58
25 Probability of Overturning Failure vs. Foundation Compressive Strength Corrective Factor	59
26 Effect of Corrective Factor Uncertainty	59
27 Effect of Bias Uncertainty	61

PROBABILISTIC CONCEPT FOR GRAVITY DAM ANALYSIS

1 INTRODUCTION

Problem

The Dam Safety Act, Public Law 92-367, directed the Secretary of the Army, through the Corps of Engineers, to initiate a program of safety inspections of dams throughout the United States. As a result of these inspections, it was learned that there are nearly 20,000 potentially hazardous dams in the United States which would seriously endanger life and cause extensive damage to property if they failed. The recent failure of the Teton Dam and the near failure of the Van Norman Dam during the 1971 San Fernando earthquake are but two instances during the past several years which have highlighted the need to develop more effective dam safety evaluation techniques to yield the best assurance of dam safety possible within the limitation of current knowledge available in the scientific and engineering communities.

The Corps of Engineers has full responsibility for the safety of nearly 550 dams, i.e., dams which the Corps plans, designs, constructs, and operates.¹ Most of these dams are either earth or gravity type as shown in Table 1.

In the conventional design process for dams, many uncertainties are associated with the forces e.g., external water pressure, uplift, earth pressure, earthquake loading, etc., and the sliding and overturning resistance capacities which must be considered in the design of dam structures. Professional engineers are aware of these uncertainties; however, little attempt has been made to quantify them. Consequently, conventional designers rely heavily on the subjective choice of the design parameters supplemented with a conservative safety factor selected on the basis of experience and judgment. Certain shortcomings may be observed with the current design practice, namely:

1. The safety of the design with respect to various modes of failure such as sliding, overturning, and overtopping is unknown, and there is not a quantitative and consistent basis for comparing the safety of various designs.

¹ Dam Safety Program in the Corps of Engineers, Report to the Federal Coordinating Council for Science, Engineering and Technology (U.S. Army Corps of Engineers, Office of the Chief of Engineers, 1977).

Table 1

Dams for Which the Corps Has Full Responsibility
 [From Dam Safety Program in the Corps of Engineers, Report to the Federal
 Coordinating Council for Science, Engineering and Technology (U.S. Army
 Corps of Engineers, Office of the Chief of Engineers, 1977)]

TYPE		AGE	
<u>DAM TYPE</u>	<u>NUMBER</u>	<u>CONSTRUCTION DATE</u>	<u>NUMBER</u>
Earth	315	Before 1900	17
Rockfill	19	1900-1909	8
Gravity	141	1910-1919	15
Arch	3	1920-1929	12
Other	60	1930-1939	70
		1940-1949	64
		1950-1959	97
		1960-1969	156
		1970-To Date	<u>99</u>
Total	<u>538</u>	Total	538

2. There is no systematic way of analyzing the degree of uncertainty and its effect on the safety of a design.

3. Additional information obtained through more extensive explorations, better quality control measures, or refined loading estimates cannot be used in evaluating the safety of a dam.

In a realistic sense, the safety of a dam is a matter of acceptable risk, and within this premise, the logical and quantitative basis for evaluating dam safety requires the concepts and methods of probability. The safety of simple engineering structures can easily be determined by comparing the resistance of the structure to the loads or load effects applied to it. Then for prescribed or assumed distributions of the load and resistance functions, expressions can be developed relating the safety of the structure to the properties of the resistance and load distributions. For larger engineering structures such as dams, both the resistance and the loading functions will depend on several variables. For example, the resistance of a dam to sliding is a function of the dead load, the geometry of the dam profile, uplift forces, compressive and shearing strengths of the foundation materials, etc. Moreover, each of these variables is subject to an estimation error or uncertainty. Techniques for incorporating these uncertainties in the design equations must be formulated before it will be possible to more fully evaluate the safety of a dam or to calculate the actual or mean safety factor for a specified risk.

Objective

The objectives of this report are: (1) to develop a probabilistic concept for gravity dam analysis in order to evaluate dam safety in terms of the various sources of uncertainty underlying the design parameters, and (2) to assess the effects of various uncertainties on dam safety.

Scope

The probabilistic dam analysis concept described in this document is applicable to concrete gravity dams, and in particular, the non-overflow sections of straight concrete dams at normal operating conditions or maximum operating conditions (i.e., normal operating condition plus earthquake effects). The loadings considered in the stability analysis include the reservoir and tailwater, the weight of the structure, internal hydrostatic pressure (uplift) at the base of the dam, and earthquake forces. The earthquake forces consist of the inertial forces caused by the horizontal acceleration of the dam itself and the hydrodynamic forces resulting from the reaction of the reservoir water against the dam. Secondary loadings have been neglected, i.e., ice, wind, wave, and earth and silt pressures have not been included;

however, if these loadings are deemed to be significant, the technique can be modified to include them. Under the prescribed loading condition, the foundation stresses must not produce a compressive failure of the foundation material, and the sliding resistance of the dam must be adequate to prevent a shear failure. For the case at hand, both of these stability requirements are evaluated at the base of the dam, i.e., the interface between the concrete dam and the foundation material. Moreover, the dam is not embedded or anchored to the foundation material, and the plane of the base is horizontal.

2 CONCRETE GRAVITY DAMS

General

The term "concrete gravity dam" refers to a solid concrete dam which depends primarily on its own weight and adhesion with the foundation to insure stability against the effects of all imposed forces. Gravity dams are usually straight, but may be slightly curved in plan. The general shape of the maximum nonoverflow section of a straight gravity dam is shown in Figure 1. The shape of the section is determined by the prescribed loading conditions, the shear resistance of the rock, and the height of the section. The upstream face of the gravity dam is usually vertical to concentrate the concrete in a location where it acts to overcome the effects of the reservoir water load. The lower portion of the upstream face may be battered to increase the thickness at the base in order to improve the base's sliding safety. The downstream face will usually have a uniform slope which is determined by both the stress and stability requirements at the base. The crest thickness may be dictated by roadway or other requirements, such as possible ice pressures or impact from floating objects. Generally, the downstream face is vertical from the downstream edge of the crest to the intersection with the sloping downstream face.

Design Forces

Several forces must be considered in the design of gravity dams. The nature of most of these forces, unfortunately, is such that an exact determination cannot be made. Thus, the magnitude, direction, and location of these forces must be assumed after consideration of all the available facts and, to a certain extent, must be based on judgment and experience. The principal forces commonly considered in the design of a concrete gravity dam are the following.

1. **Dead Load.** The dead load is the weight of concrete plus appurtenances such as gates and bridges. In the determination of the dead load, relatively small voids, such as galleries, normally are not deducted. The unit weight of concrete is generally assumed to be 150 pcf unless specific data are available from a concrete mix analysis.

2. **Reservoir and Tailwater Pressures.** Reservoir and tailwater loads are obtained from reservoir operations studies. A triangular distribution of the static water pressure acting normal to the face of the dam is assumed in the design of most dams. Although the weight of water varies slightly with temperature, the weight usually adopted in the design of dams is 62.5 pcf.

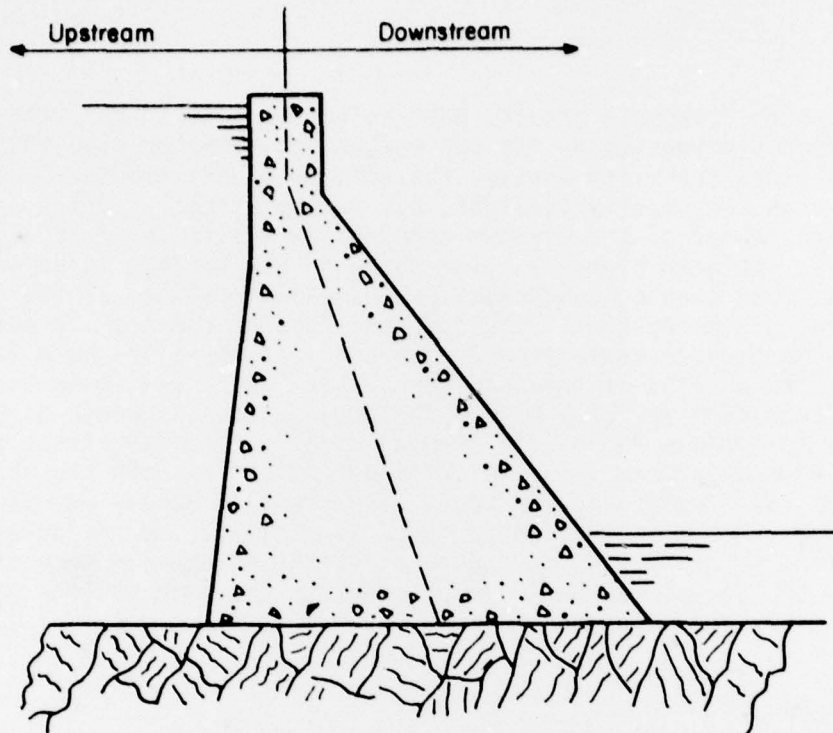

Figure 1. General profile of nonoverflow section of a gravity dam.

3. Internal Hydrostatic Pressure. Dams are subject to water pressure not only on exposed faces but also on their bases. These internal pressures produce uplift, which causes a reduction in the effective weight of the structure. The distribution of the internal hydrostatic pressure along a horizontal section through a gravity dam is usually assumed to vary linearly from full reservoir pressure at the upstream face to zero or tailwater pressure of the downstream face and to act over the entire area of the section. The pressure distribution may be adjusted to reflect the size, location, and spacing of drains, if they are used. When the line of drains intersects the foundation near the upstream face, which is consistent with the requirements for gallery locations, the pressure distribution is normally assumed to vary linearly, but is adjusted by a hydrostatic pressure intensity factor, K , as shown in Figure 2.²

4. Earthquake Forces. In regions where earthquakes occur, dams must resist the inertia effects caused by the sudden movement of the earth's crust. Two types of earthquake forces are produced: the

² EM 1110-2-2200, Gravity Dam Design (U.S. Army Corps of Engineers, 1958).

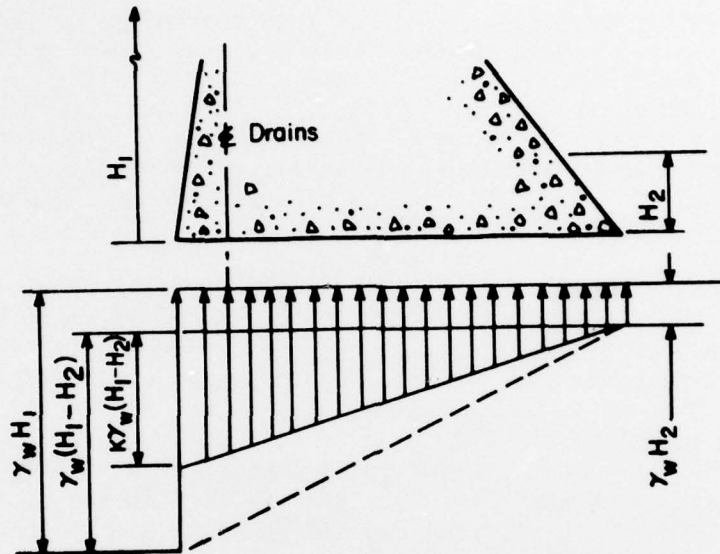

Figure 2. Distribution of internal hydrostatic pressure. From EM 1110-2-2200, Gravity Dam Design (U.S. Army Corps of Engineers, 1958).

inertial force due to the acceleration of the mass of the dam and the hydrodynamic force resulting from the reaction of the reservoir water on the dam. For a gravity dam with a full reservoir, the most unfavorable direction of the earthquake is upstream normal to the axis, which produces horizontal forces which act downstream.

The force imposed on the mass of the dam may be determined by the equation

$$P_0 = \alpha W_0 \quad [\text{Eq 1}]$$

where P_0 = inertial force due to earthquake per unit length

α = ratio of the earthquake acceleration to gravity

W_0 = total dead weight of the dam per unit length

The increase in water pressure on the dam caused by the earthquake acts concurrently with the above force. The distribution of these increased pressures is usually assumed to be parabolic, and the force may be computed using the following equation

$$P_e = 2/3 C \alpha H_1^2 \quad [\text{Eq 2}]$$

where P_e = total hydrodynamic force due to earthquake per unit length

H_1 = height of the reservoir water

C = factor depending principally on the height of the dam and the earthquake period, t_e , as shown in Figure 3.

Typically, an acceleration of $0.1g$, i.e., $\alpha = 0.1$, has been used in the regions where moderate to severe shocks have been experienced or where conditions are unfavorable. In more favorable regions this factor has been reduced to $0.05g$. The period of vibration of the earthquake, t_e , is usually assumed to be 1 second.

5. Foundation Reactions. In general, the resultant of all horizontal and vertical forces on the dam including uplift, must be balanced by an equal and opposite reaction at the foundation, consisting of the total vertical reaction and the total horizontal shear and friction. Moreover, for the dam to be in static equilibrium, the location of this force must be such that the summation of moments is equal to zero. The distribution of the vertical reaction is assumed to be trapezoidal for convenience only, with the knowledge that the elastic and plastic properties of the foundation material and the concrete affect the actual distribution. The problem of determining the actual distribution is complicated by the horizontal reaction, internal stress relations, and other theoretical considerations. Also, the variation of the foundation materials with depth, and geological discontinuities, which disrupt the tensile and shearing resistance of the foundation, make the problem more complex. The maximum foundation pressure at any point is equal to the computed foundation reaction plus the uplift pressure.

In addition to the principal forces described above, there are secondary forces that may be considered where warranted. These include the following:

1. Earth and Silt Pressures. In the design of abutment sections, some depths of backfill usually must be considered. Silt pressures on both the upstream and downstream faces of the dam may develop during the expected useful life of the dam and should be given some consideration.

2. Ice Pressure. If ice will develop to appreciable thickness and remain for a long duration, ice pressure should be considered in the design of the dam. For dams in this country, ice pressures usually will not exceed $10,000$ plf of the dam and should be applied at normal pool elevation.

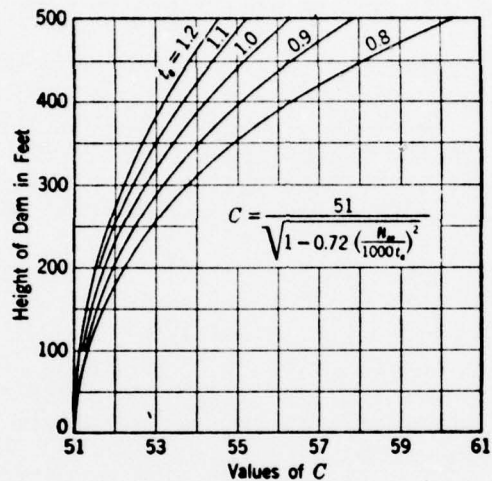

Figure 3. Value of earthquake factor C.

3. Wave Pressures. In some instances, wave pressures can have an effect on the dam. However, usually the height of the waves is a more important factor since it establishes the freeboard requirement for the dam.

4. Wind Pressures. Wind pressures of 30 psf are usually used in the design of dams. However, unless there are large appurtenances or freeboard requirements, these forces are small.

Failure Mechanisms

There are two direct ways in which a gravity dam may fail:

1. By sliding on a horizontal or nearly horizontal joint above the foundation, on the foundation, or on a horizontal or nearly horizontal seam in the foundation.
2. By overturning on a horizontal joint within the dam, at the base, or at a plane below the base.

The direct cause of sliding is the presence of horizontal forces greater than the combined shearing resistance of the joint or base and the static friction induced by the vertical forces.

The direct cause of pure overturning, not preceded by some other type of failure, if tension is ignored, is the presence of horizontal forces great enough compared to the vertical forces to cause the resultant of all forces acting on the dam above any horizontal plane, including uplift, to lie outside the limits of the dam.

As the resultant approaches the face, the compressive stresses increase rapidly, hence overturning would be preceded and accelerated by a compression failure. In fact, a dam with the resultant well inside the base may overturn if the toe of the dam fails due to crushing or other causes and reduces the effective length of the joint or base sufficiently to cause the resultant to lie outside the effective base.

A dam may start to overturn but finally fail by sliding. If the resultant passes appreciably outside the middle third (or kern, if the base is of irregular form), a horizontal tension crack may occur, which reduces the shearing strength of the joint or base. Also, the admission of reservoir water pressure to the fissure increases the uplift, reducing the net reaction and the frictional resistance to horizontal motion. As a result, sliding may occur.

Loading Conditions

The following loading conditions and requirements are generally considered in the design of moderate height gravity dams:³

1. Construction Condition. Dam completed but no water in reservoir, no tailwater, wind load on downstream face.
2. Normal Operating Condition. Pool elevation at top of closed spillway gates, where spillway is gated, and at spillway crest, where spillway is ungated. Minimum tailwater elevation for gated and ungated spillways. Ice pressure, if applicable.
3. Induced Surcharge Condition. Pool elevation at top of partially opened gate. Tailwater pressure at full value for nonoverflow section and 60 percent of full value for overflow section. Ice pressure, if applicable.

³EM 1110-2-2200, Gravity Dam Design (U.S. Army Corps of Engineers, 1958).

4. Flood Discharge Condition. Reservoir at maximum flood pool elevation. All gates open and tailwater at flood elevation. Tailwater pressure at full value for nonoverflow section; 60 percent of full value for overflow sections for all conditions of deep flow over spillway, except that full value will be used in all cases to compute the uplift. No ice pressure.

5. Construction Condition With Earthquake. Earthquake acceleration in a downstream direction. No water in reservoir. No wind load. No tailwater.

6. Normal Operating Condition With Earthquake. Earthquake acceleration in an upstream direction. Reservoir at top of closed gate for gated spillways and at spillway crest for ungated spillways. Minimum tailwater. No ice pressure.

Stability Requirements

The basic requirements for stability of a gravity dam for all conditions of loading are:

1. That it be safe against overturning at any horizontal plane within the dam, at the base, or at a plane below the base.
2. That it be safe against sliding on any horizontal plane within the dam, on the foundation, or on any horizontal or nearly horizontal seam in the foundation.
3. That allowable unit stresses in the concrete or in the foundation material shall not be exceeded.

Sliding and Overturning Criteria

The horizontal forces acting on a dam tend to cause the structure to slide along horizontal planes. Resistance to sliding at or below the base is a function of the shearing strength of the foundation, or at any plane above the base, the shearing strength of the concrete in the dam. Experience has shown that the shearing resistance of the foundation or concrete need not be investigated if the ratio of horizontal forces to vertical forces ($\Sigma H/\Sigma V$) is such that a reasonable safety factor results. This will require that the ratio of $\Sigma H/\Sigma V$ be well below the coefficient of sliding friction of the material.

When the resultant of all forces acting above any horizontal plane through a dam intersects that plane outside of its middle third or kern, tensile stresses are set up. Since the tensile strength of concrete is usually considered to be zero, it is generally required for all normal loading that the resultant intersect the plane within the middle third

or kern. However, because of the short duration of earthquake forces, it is considered justifiable to modify this requirement when these forces are included.

Table 2 indicates acceptable limits of the location of the resultant and the maximum sliding factor for all loading conditions. Where the sliding factor exceeds the values given, the shearing resistance should be investigated.

Shear Friction Factor of Safety

Where the ratio of $\Sigma H/\Sigma V$ indicates the need to investigate the shearing resistance to horizontal movement, the shear-friction formula should be used to determine the factor of safety inherent in the foundation or concrete. This factor of safety may be evaluated as follows:

$$(S_{s-f}) = \frac{Q}{\Sigma H} = \frac{\Sigma V \tan \phi + sA}{\Sigma H} \quad [\text{Eq 3}]$$

where (S_{s-f}) = shear-friction safety factor

s = unit shearing strength of material

A = area of the horizontal plane considered

Q = sliding resistance of the dam per unit length

ϕ = angle of internal friction of foundation material

A minimum shear-friction safety factor (S_{s-f}) of 4 is generally required for the maximum loading condition.

Analysis Method

Generally, the Gravity Method of stress and stability analysis is used in the preliminary studies of gravity dams and the final designs of straight gravity dams in which the transverse contraction joints are neither keyed nor grouted. The gravity method provides an approximate determination of stresses in a section of a gravity dam. Each section of the dam is assumed to act independently and is treated as if it were a cantilever with the loads transmitted to the foundation by cantilever action and resisted by the weight of the cantilever. The forces acting on the cantilever element, including uplift and earthquake, are shown for the normal loading conditions in Figure 4. Symbols used to define this loading condition are presented in the appendix.

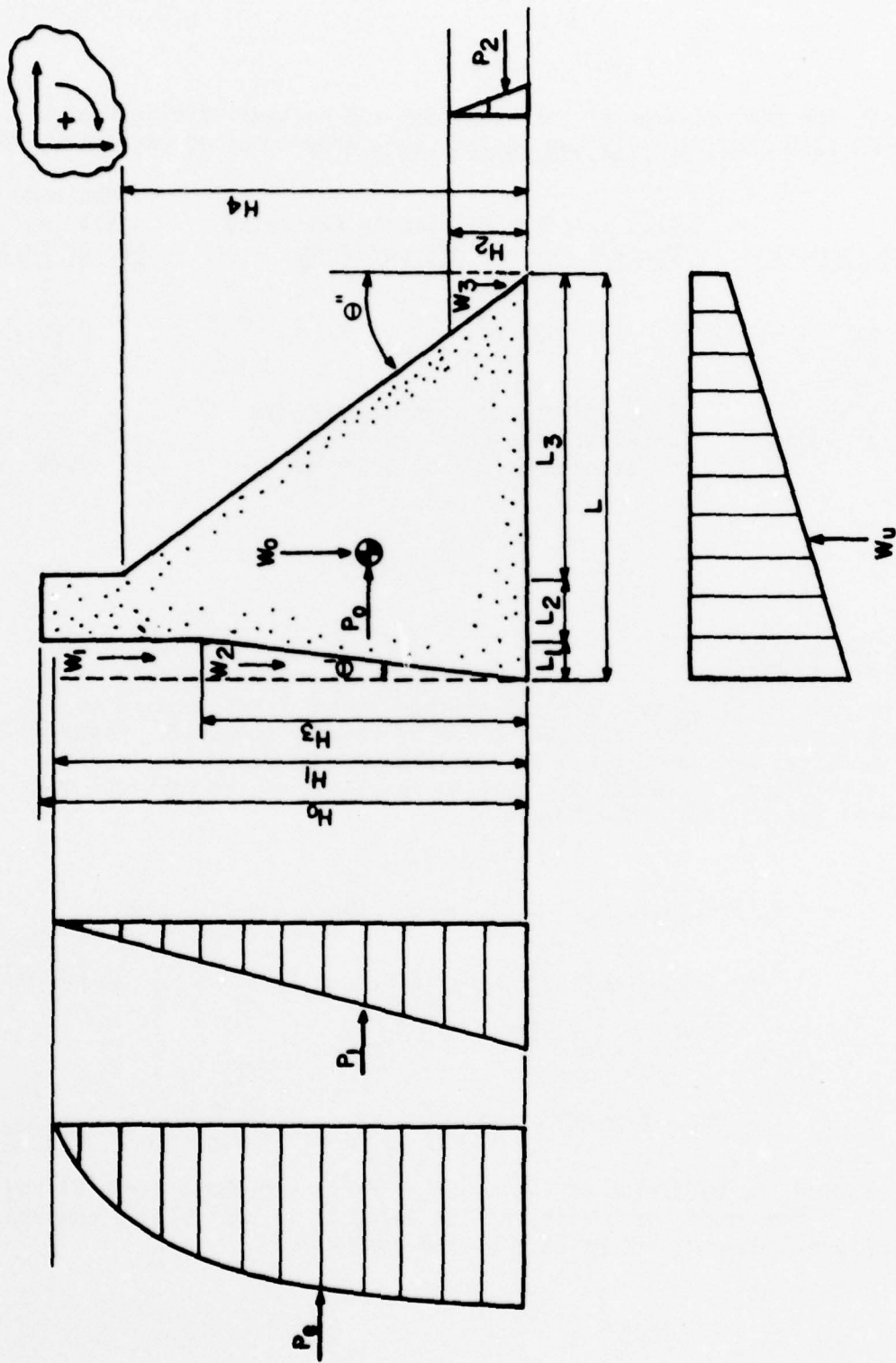

Figure 4. Forces acting on nonoverflow section of gravity dam.

Table 2

Limits for the Location of the Resultant and Maximum Sliding Factor
(From EM 1110-2200, Gravity Dam Design (U.S. Army Corps of Engineers, 1958))

<u>Loading Condition</u>	<u>Resultant to Fall Within Following Central Percent of Base Width</u>	<u>Maximum Sliding Factor $\Sigma H/\Sigma V$</u>
I	33 1/3	----
II	33 1/3	0.65
III	33 1/3	0.65
IV	33 1/3	0.65
V	(For conditions V and VI, within base but allowable foundation pressure must not be exceeded)	----
VI		0.85

Forces and Moments

The resultants of the vertical and horizontal forces acting on the section of the dam shown in Figure 4 can be readily computed. Assuming positive forces and moments are as indicated by the directional arrows shown in Figure 4, the equations for the resultant of the vertical and horizontal forces are, respectively,

$$V = \gamma_c (1/2L_1H_3 + L_2H_0 + 1/2L_3H_4) + \gamma_w L_1(H_1 - H_3) + 1/2\gamma_w L_1H_3 + 1/2\gamma_w H_2^2 \tan\theta'' - \gamma_w L [H_2 + 1/2K(H_1 - H_2)] \quad [\text{Eq 4}]$$

and

$$\Sigma H = 2/3\alpha H_1^2 + 1/2\gamma_w H_1^2 + \alpha W_0 - 1/2\gamma_w H_2^2 \quad [\text{Eq 5}]$$

Likewise, by summation of the moments of the component parts of the loads about the center of gravity of the base, it is possible to compute the overturning moment at the base of the dam, M_0 .

$$\begin{aligned}
M_0 = & 4/15\alpha H_1^3 + 1/6\gamma_w H_1^3 - 1/6\gamma_w H_2^3 + \alpha\gamma_c (1/6L_1 H_3^2 + 1/2L_2 H_0^2 + 1/6L_3 H_4^2) \\
& - 1/2\gamma_w L_1 (H_1 - H_3)(L - L_1) - 1/2\gamma_w L_1 H_3 (1/2L - 1/3L_1) - 1/2\gamma_c L_1 H_3 (1/2L - 2/3L_1) \\
& - \gamma_c L_2 H_0 (1/2L - L_1 - 1/2L_2) + 1/2\gamma_c L_3 H_4 (1/2L - 2/3L_3) + 1/2\gamma_w H_2 \tan\theta' \\
& \cdot (1/2L - 1/3H_2 \tan\theta') + 1/12\gamma_w K (H_1 - H_2)^2 \quad \text{[Eq 6]}
\end{aligned}$$

In turn, the vertical foundation pressure can be determined at any point on the base from the equations

$$P'_r = \frac{\Sigma V}{A} - \frac{M_0 m}{I} \quad \text{[Eq 7]}$$

$$P''_r = \frac{\Sigma V}{A} + \frac{M_0 m}{I} \quad \text{[Eq 8]}$$

where P'_r , P''_r = unit vertical reaction in the foundations at the upstream and downstream faces of the dam, respectively

m = distance from the center of gravity of the base to the point under consideration.

For a section of a gravity dam of unit length, certain simplifications are possible. The base of the section is a rectangle of unit width and length L ; therefore, $A = L$. The center of gravity is at the midpoint, and $m = L/2$, and $I = 1/12 L^3$. Substituting these values in the above expression yields

$$P'_r = \frac{\Sigma V}{L} - \frac{6M_0}{L^2} \quad \text{[Eq 9]}$$

$$P''_r = \frac{\Sigma V}{L} + \frac{6M_0}{L^2} \quad \text{[Eq 10]}$$

To obtain the maximum vertical foundation pressures, the uplift pressures must be added to the vertical foundation pressure.

$$P'_v = \frac{\Sigma V}{L} - \frac{6M_o}{L^2} + P'_u \quad [\text{Eq 11}]$$

$$P''_v = \frac{\Sigma V}{L} + \frac{6M_o}{L^2} + P''_u \quad [\text{Eq 12}]$$

where P'_v, P''_v = maximum vertical unit pressure on the upstream and downstream faces of the dam, respectively

P'_u, P''_u = unit uplift pressures at the base of the dam on the upstream and downstream faces of the dam, respectively.

The maximum vertical compressive stresses, however, are not the maximum stresses which occur in the dam. The maximum stresses occur at the ends of joints, on inclined planes, normal to the face of the dam. In the general case where external water forces are involved due to the reservoir and tailwater, the corresponding inclined pressures are

$$P'_i = P'_v \sec^2 \theta' - P'_n \tan^2 \theta' \quad [\text{Eq 13}]$$

and

$$P''_i = P''_v \sec^2 \theta'' - P''_n \tan^2 \theta'' \quad [\text{Eq 14}]$$

where P'_i, P''_i = included pressure at the upstream and downstream faces, respectively

θ', θ'' = angle between the upstream and downstream faces and the vertical, respectively

P'_n, P''_n = external normal pressures at the upstream and downstream faces, respectively.

Whether the maximum pressure in the foundation is equal to the inclined pressure in the dam at the base or to the maximum vertical foundation pressure is frequently the subject of debate. Undoubtedly, stress conditions change rapidly in the rock beneath the toe of the dam, but it seems rational and on the side of safety to assume that the maximum stress in the rock in immediate contact with the base of the dam equals the inclined toe stress in the dam.

3 RELIABILITY THEORY

General

In the classical concept of reliability, the random resistance, R , and the random load (or load effect), S , are known and the uncertainties associated with the inherent randomness are described by known probability distributions. For the practical case at hand, this concept is inadequate. First, R and S are not known, and it is only possible to predict these variables using theoretical models R and S , respectively. Such predictions are invariably imperfect, thus introducing additional uncertainties. Second, the uncertainties underlying the resistance and load effects must be given in terms of quantitative measures.

Extended Reliability Theory

Recent developments in reliability theory have extended the classical concept to yield a first-order approximation for practical applications, such as computing the probability of failure of a concrete gravity dam.⁴ The essence of this theory and a synopsis of the relevant equations for computing the means, uncertainties, and probability of failure are presented below.

1. Mean and Uncertainty. Let Y be a random variable representing, for example, the resistance, R , or the applied load effect, S , in a structure. Invariably, Y is a function of other variables; e.g.,

$$Y = f(X_1, X_2, \dots, X_n) \quad [\text{Eq 15}]$$

Presumably, the model for Y , as represented by the function in Eq 15, as well as X_1, \dots, X_n , would represent reality exactly. In engineering practice, however, this generally is not the case; f and X_1, \dots, X_n must be predicted or estimated, and thus are subject to prediction errors. To adjust for an imperfect prediction, corrective factors N_f and N_{X_i} are introduced, such that

$$f = N_f \hat{f} \quad [\text{Eq 16}]$$

⁴ A. H-S. Ang and C. A. Cornell, "Reliability Bases of Structural Safety and Design," ASCE, *Journal of the Structural Division*, Vol 100, No. St 9 (1974), pp 1755-1769.

and

$$X_i = N_{X_i} \hat{X}_i \quad [\text{Eq 17}]$$

where \hat{f} is the empirical or theoretical function adopted as a model of f , and \hat{X}_i is the model of X_i . Here, N_f , N_{X_i} , and \hat{X}_i are random variables with means \bar{N}_f , \bar{N}_{X_i} , and \bar{X}_i , and coefficients of variation (c.o.v.) δ_f , δ_{X_i} , and $\delta_{\hat{X}_i}$, respectively. The uncertainties associated with the basic variability in X_i are, therefore, measures by δ_{X_i} , whereas $\delta_{\hat{X}_i}$ represents the prediction uncertainty in X_i . Consistent with the first-order approximation, $\delta_{\hat{X}_i}$ will be ascribed entirely to the uncertainty in the predicted \bar{X}_i . Furthermore, the mean values \bar{N}_f and \bar{N}_{X_i} represent, respectively, the bias in the model f (usually a deterministic function) and the estimated mean \bar{X}_i .

By first-order approximation, the total c.o.v. of X_i then (by virtue of Eq 17) is

$$\Omega_{X_i} = \sqrt{\delta_{X_i}^2 + \Delta_{X_i}^2} \quad [\text{Eq 18}]$$

Similarly, the total c.o.v. of f is

$$\Omega_f = \sqrt{\delta_f^2 + \Delta_f^2} \quad [\text{Eq 19}]$$

where δ_f represents the basic variability about the model function f ; and Δ_f denotes any imperfections in the form of the equation used.

Substituting Eqs 16 and 17 into Eq 15, and using a first-order approximation, the mean and c.o.v. of Y are easily found to be

$$\bar{Y} = \bar{N}_f \hat{f}(\bar{N}_{X_1} \bar{X}_1, \bar{N}_{X_2} \bar{X}_2, \dots, \bar{N}_{X_n} \bar{X}_n) \quad [\text{Eq 20}]$$

and

$$\Omega_Y^2 = \Omega_f^2 + \frac{\bar{N}_f^2}{\bar{Y}^2} \left[\sum_{i=1}^n \left(\frac{\partial f}{\partial X_i} \right)^2 \bar{N}_{X_i}^2 \bar{X}_i^2 \Omega_{X_i}^2 \right. \quad [\text{Eq 21}]$$

$$\left. + \sum_{i=1}^n \sum_{\substack{j=1 \\ i \neq j}}^n \left(\frac{\partial f}{\partial X_i} \right) \left(\frac{\partial f}{\partial X_j} \right) \rho_{X_i, X_j} \bar{N}_{X_i} \bar{N}_{X_j} \bar{X}_i \bar{X}_j \Omega_{X_i} \Omega_{X_j} \right]$$

where the derivations are evaluated at the mean value and ρ_{X_i, X_j} is the correlation coefficient between X_i and X_j .

2. Probability of Failure. The probability of failure is defined as

$$P_f \approx F_{n_2} \left[\frac{-\ln\left(\frac{\bar{R}}{\bar{S}}\right)}{\sqrt{\Omega_R^2 + \Omega_S^2}} \right] \quad [\text{Eq 22}]$$

where F_{n_2} = cumulative distribution function of n_2

$$n_2 = \frac{\ln\left(\frac{R}{S}\right) - \ln\left(\frac{\bar{R}}{\bar{S}}\right)}{\sqrt{\Omega_R^2 + \Omega_S^2}}$$

R, S = true random resistance and true random load, respectively

\hat{R}, \hat{S} = models of R and S

\bar{R}, \bar{S} = mean values of \hat{R} and \hat{S} , respectively

$\Omega_R = \sqrt{\delta_R^2 + \Delta_R^2}$ = coefficient of variation, representing measure of the total uncertainty of resistance, R

$\delta_R = \frac{\sigma_R}{\bar{R}}$ = coefficient of variation, representing measure of the basic variability of resistance, R

Δ_R = coefficient of variation of resistance, representing a measure of the errors in predicting \bar{R}

$\Omega_S = \sqrt{\delta_S^2 + \Delta_S^2}$ = coefficient of variation, representing measure of the total uncertainty of load, S

$\delta_S = \frac{\sigma_S}{\bar{S}}$ = coefficient of variation, representing measure of the basic variability of load, S

Δ_S = coefficient of variation of load, representing a measure of the errors in predicting \bar{S} .

Eq 22 is to be used when the total uncertainties are not large (≤ 0.3). Otherwise, a more general form is

$$P_f = 1 - \Phi \left\{ \frac{\ln \left(\frac{R}{S} \right) \frac{\sqrt{1 + \Omega_S^2}}{\sqrt{1 + \Omega_R^2}}}{\sqrt{\ln \left[(1 + \Omega_R^2)(1 + \Omega_S^2) \right]}} \right\} \quad [\text{Eq 23}]$$

Distribution Function

The probability of failure, as given in Eq 22, depends on the distribution functions for R and S. Consequently, the probability of failure may be sensitive to the assumed distribution functions if the risk is very small (e.g., $< 10^{-5}$). This is a consequence of the behavior of the extreme tails of the distribution functions. Unfortunately, when the available data are limited to the central range of the variates, it is virtually impossible to determine the validity of one distribution function versus several others. Moreover, the choice of the distribution should recognize the practical considerations such as convenience of implementation and availability of probabilistic information. In similar engineering applications, the log-normal distribution has been favored; therefore, it was selected for this study.

4 PROBABILISTIC LOAD AND RESISTANCE MODELS

General

In the stability analysis of concrete gravity dams, the horizontal force, sliding resistance, and foundation pressure are functions of several variables. For example, the horizontal force is a function of the reservoir and tailwater elevations, the earthquake acceleration coefficient, and the earthquake factor. The sliding resistance is a function of the reservoir and tailwater elevations, the internal hydrostatic pressure (i.e., uplift), the angle of internal friction of the foundation material, and the unit shear stress (cohesion) along the failure plane. Likewise, the foundation pressure is a function of many of these variables. Since the profile of a nonoverflow section of a dam is usually well defined, the dimensions of the section will be considered constant. Likewise, the unit weights of concrete and water will be considered constant, since their basic variabilities are quite small. Therefore, the principal random variables in the stability analysis of concrete gravity dams are:

C = the earthquake factor

H_1 = height of the reservoir water

H_2 = height of the tailwater

K = hydrostatic pressure intensity factor

s = unit shear strength along the failure plane

σ = unit compressive strength of the foundation material

α = earthquake acceleration coefficient

ϕ = angle of internal friction of the foundation material

To apply the extended reliability theory formulated in the previous section to concrete gravity dams, probabilistic models of the load and resistance functions for the sliding and overturning modes of failure must be developed which incorporate corrective factors and coefficients of variation terms to account for basic variabilities and prediction uncertainties. Moreover, some of the sources for the basic variabilities and prediction uncertainties associated with the principal variables need to be identified, although generally they cannot be quantified until specific data and information for an actual dam are available.

Horizontal Force Model

Equations for Mean and Uncertainty

The horizontal forces tending to cause sliding of the dam are summarized in Eq 5. The major variables in this equation are H_1 , C , α , and H_2 ; thus, correction factors N_{H_1} , N_C , N_α , N_{H_2} , respectively, and N_h must be introduced into Eq 5 to yield the mean value of total horizontal force, H , as

$$H = N_h [2/3 N_\alpha N_C N_{H_1}^2 \alpha C H_1^2 + 1/2 \gamma_w N_{H_1}^2 H_1^2 + N_\alpha \alpha W_0 - 1/2 \gamma_w N_{H_2}^2 H_2^2] \quad [\text{Eq 24}]$$

Here and in succeeding expressions, bars above the random variables to denote mean values have been deleted to simplify the presentation; however, it should be understood that mean values of these random variables are implied.

To evaluate the uncertainty associated with the total horizontal force, it is necessary to evaluate Eq 21. For the purpose of this study, H_1 and H_2 are assumed to be correlated and the correlation coefficients between the other variables are assumed to be zero; i.e., they are statistically independent. Thus, the total uncertainty associated with the total horizontal force is

$$\begin{aligned} \Omega_H^2 = & \Omega_h^2 + \frac{N_h^2}{H^2} [(4/3 \alpha C H_1 + \gamma_w H_1)^2 N_{H_1}^2 H_1^2 \Omega_{H_1}^2 + (\gamma_w H_2)^2 N_{H_2}^2 H_2^2 \Omega_{H_2}^2 \\ & + (2/3 C H_1^2 + W_0)^2 N_\alpha^2 \alpha^2 \Omega_\alpha^2 + 2/3 (\alpha H_1^2)^2 N_C^2 C^2 \Omega_C^2 \\ & - (4/3 \alpha C H_1 + \gamma_w H_1) (\gamma_w H_2) \rho_{H_1 H_2} N_{H_1} N_{H_2} H_1 H_2 \Omega_{H_1} \Omega_{H_2}] \end{aligned} \quad [\text{Eq 25}]$$

Bias and Uncertainty of Principal Variables

Height of Reservoir and Tailwater. Most gravity dams will have gated spillways or outlet works to control the discharge of the reservoir water for irrigation, electrical power generation, downstream water control, etc. Normally, there will not be large fluctuations in the reservoir and tailwater elevations. Consequently, the bias and uncertainty associated with the reservoir and tailwater elevations will be quite small, though finite.

Earthquake Acceleration Coefficient. In the pseudo-dynamic approach to earthquake loading of concrete gravity dams, additional static forces are included in the basic design equations to represent the inertial forces on the body of the dam and the water in the reservoir during an earthquake. Typically, an earthquake acceleration coefficient of 0.05 g to 0.1 g has been adopted to account for the effects of horizontal accelerations, and the effects of vertical accelerations are frequently ignored. Recently, the seismic zoning maps for the United States were updated, and the earthquake coefficients in a number of areas were increased to a maximum value of 0.15 g (Figures 5 through 7.)⁵ However, the problem remains that these maps are based on estimates of the maximum ground shaking experienced during the recorded historical period with only minor consideration of how frequently such motions have occurred.

What is actually needed in planning the design of a dam in a region of potential earthquake activity is a specification of the maximum ground motion expected at the site during the useful life of the dam; i.e., a site-dependent seismic hazard analysis should be conducted to synthesize all regional information and general knowledge about earthquakes to obtain the probabilities associated with the occurrence of different motions at the site. Such analysis should realistically model the fault system, the occurrence rate for earthquake magnitudes of interest, and the attenuation relationship from the source to the site; in addition, the analysis should account for uncertainty due to the degree of scatter in the data and the prescribed relationships used in the model. Through such analysis, the annual probabilities (or return periods) associated with various intensities of ground motion at the site can be derived systematically and objectively, using the seismic information available for a region and the relevant physical relationships of earthquakes. Moreover, by computing the hazard at various sites in the region, seismic hazard maps can be constructed in the form of isoseismal contours corresponding to given time periods and probabilities of non-exceedance.

Recently, the Applied Technology Council, an affiliate of the Structural Engineers Association of California, made a first attempt at incorporating seismic risk procedures into zoning maps for the United States as part of the Cooperative Federal Program in Building Practices for Disaster Mitigation. These seismic hazard maps were developed to incorporate the attenuation of ground motions with distance to the site from the anticipated earthquake sources and to have the probability of exceeding the design ground shaking roughly the same in all parts of the country. The maps did not, however, include detailed representation of the fault system or provisions for incorporating uncertainty. To represent the intensity of ground shaking, two parameters were adopted:

⁵ ER 1110-2-1806, Earthquake Design and Analysis for Corps of Engineer Dams (U.S. Army Corps of Engineers, 1977).

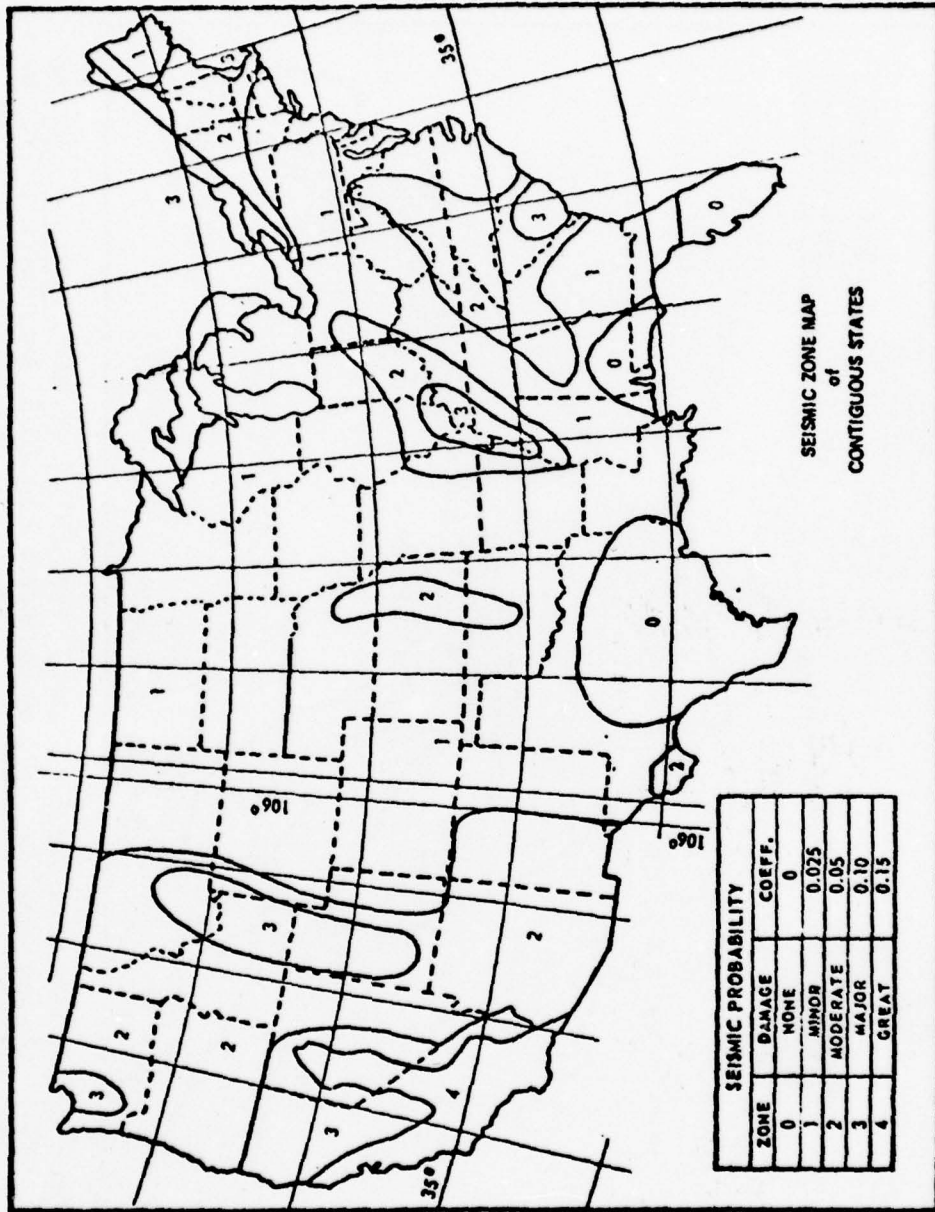

Figure 5. Seismic zone map for contiguous states. From ER 1110-2-1806, Earthquake Design and Analysis for Corps of Engineers Dams (U.S. Army Corps of Engineers, 1977).

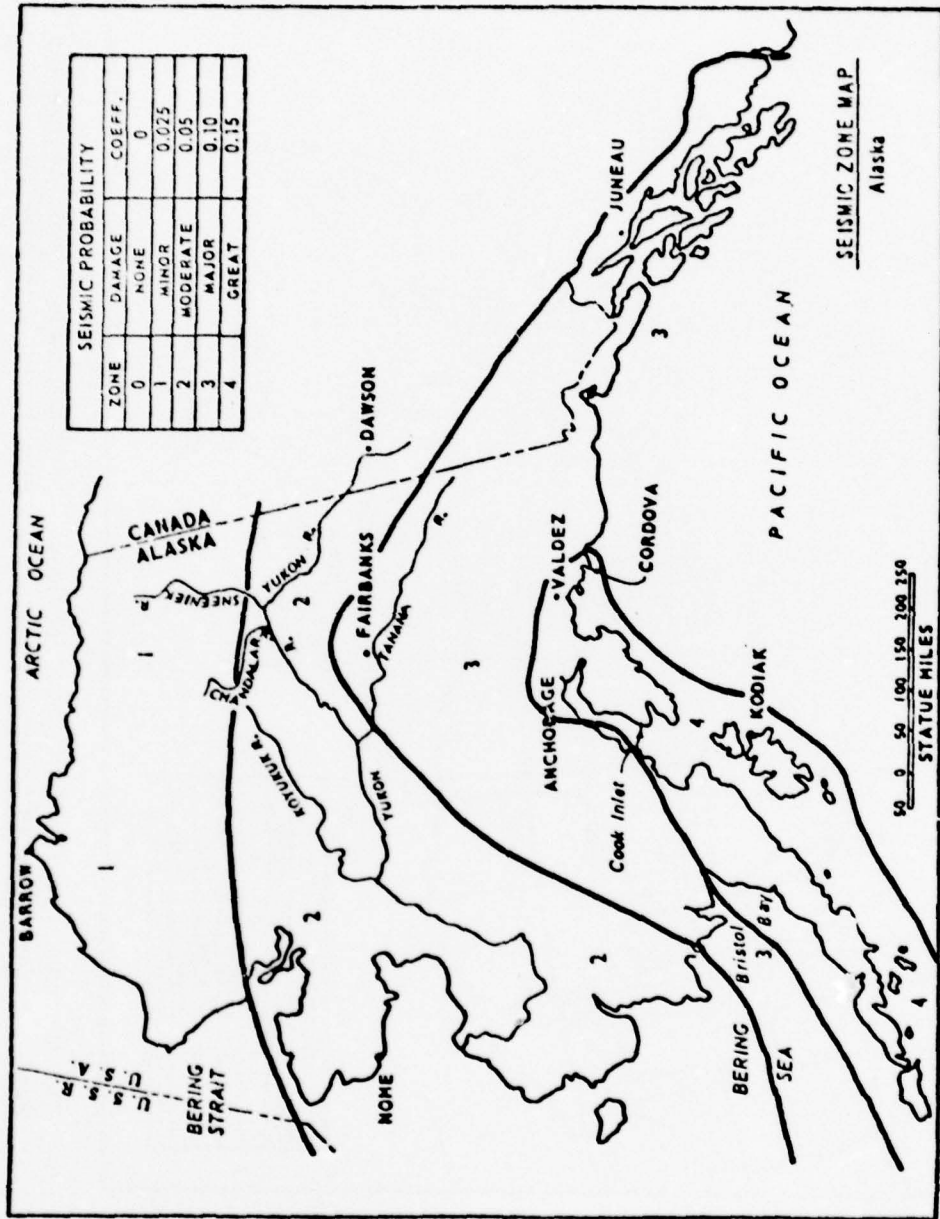

Figure 6. Seismic zone map for Alaska. From ER 1110-2-1806, Earthquake Design and Analysis for Corps of Engineers Dams (U.S. Army Corps of Engineers, 1977).

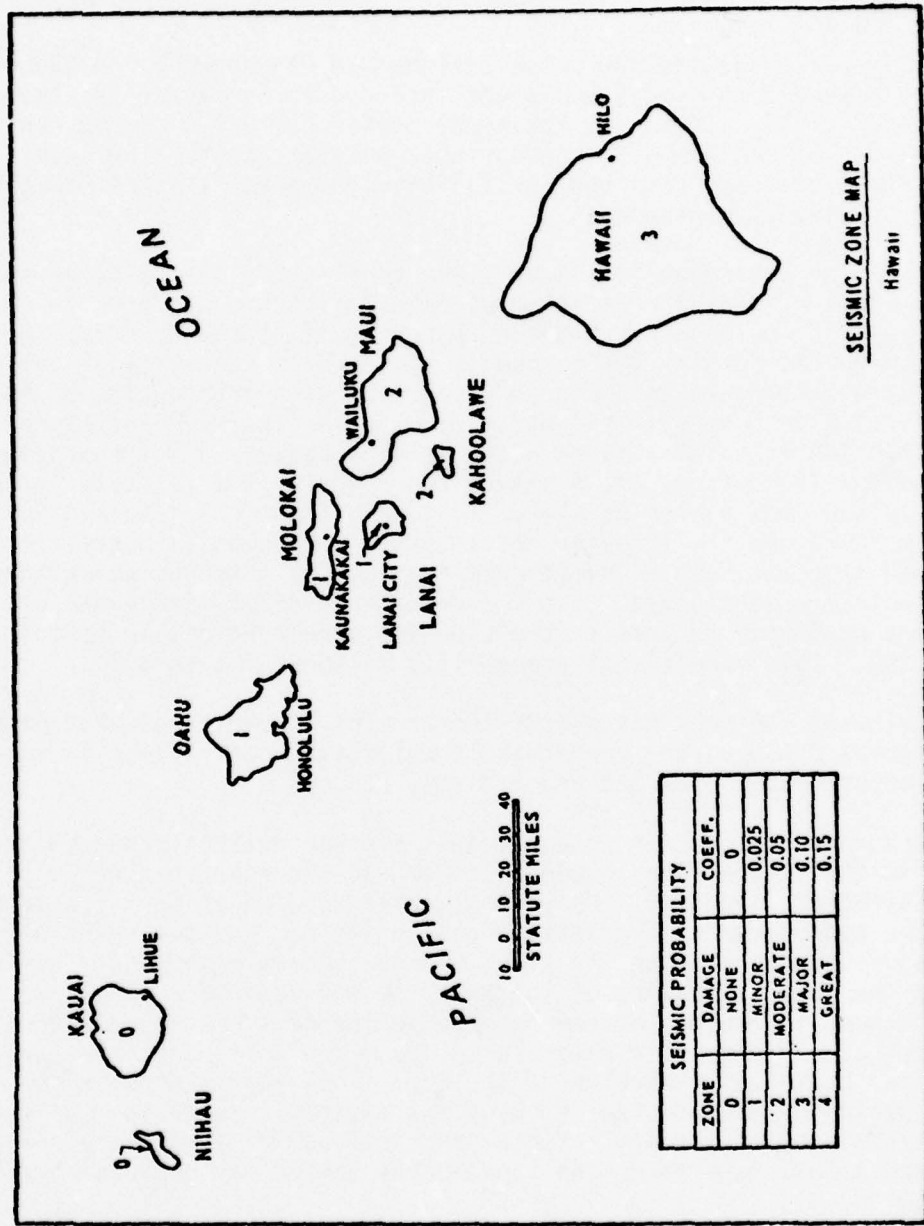

Figure 7. Seismic zone map for Hawaii. From ER 1110-2-1806, Earthquake Design and Analysis for Corps of Engineers Dams (U.S. Army Corps of Engineers, 1977).

effective peak acceleration (EPA) and effective peak velocity-related acceleration (EPV). The maps of EPA and EPV are shown in Figures 8 and 9, respectively.

In Figure 8, the maximum value assigned to EPA anywhere on the map is 0.4 g; however, this maximum is not intended to represent an absolute upper bound of EPA. There are locations inside the 0.4 g contour where higher values of EPA would be appropriate; however, contouring such small areas would have required special site-dependent studies similar to those previously mentioned.

The map of EPV shown in Figure 9 was constructed by modifying the EPA map; however, a different attenuation relationship was used in the eastern half of the country. In the western half of the country, the distance required for the EPV to reduce to one-half the original value from a large earthquake is about 80 miles. Data on attenuation of Modified Mercalli Intensity in the eastern United States have indicated that within 100 miles of a large earthquake, attenuation was the same as in the west. Thereafter, the distance required for the velocity to be reduced by one half almost doubles. These modifications resulted in the map shown in Figure 9. In using acceleration and velocity coefficients from these maps, it must be remembered that forces computed using these coefficients are conditional upon the occurrence of an earthquake of sufficient magnitude to produce these design accelerations or velocities at the site. This conditional probability is about 0.1 to 0.2.

In view of the previous discussion and the disparity between Figure 5 and Figures 8 and 9, the earthquake acceleration coefficient is subject to considerable bias and uncertainty.

Earthquake Factor. In recent years, a great deal of research has focused on the interaction between the dam and the reservoir water during earthquake loadings. While the Westergaard equation for approximating the hydrodynamic interaction between the dam and the reservoir was a major contribution in its time, recent studies have shown that neglecting the compressibility of the water in the reservoir can lead to serious errors in estimating the natural period of vibration of the dam. The effect of the reservoir water is to cause a significant increase in the natural period of vibration of the dam. This lengthening of the natural period depends on the depth of the reservoir water and the modulus of elasticity of the dam. For a practical range of values of elasticity and a full reservoir, the fundamental period may increase by 25 to 50 percent.⁶

⁶ P. Chakrabarti and A. K. Chopra, "Earthquake Analysis of Gravity Dams Including Hydrodynamic Interaction," Earthquake Engineering and Structural Dynamics, Vol 2 (1973), pp 143-160.

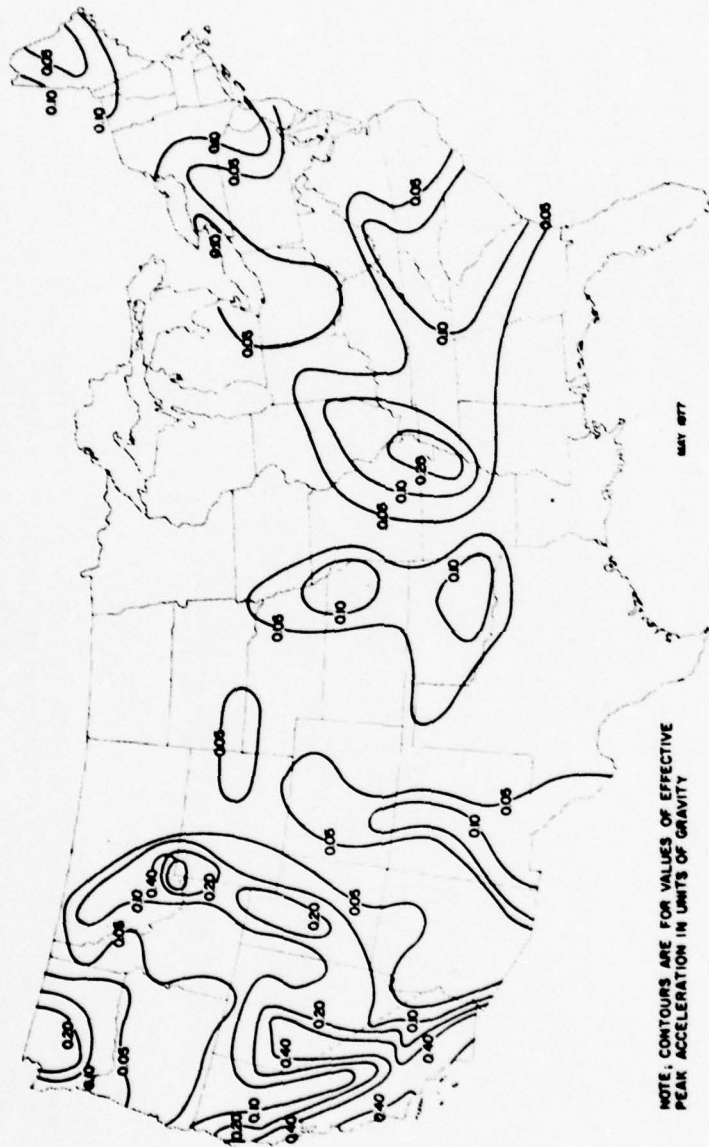

Figure 8. Contour map of effective peak acceleration (EPA) for 48 contiguous states (contours represent EPA levels with nonexceedance probability of between 80 percent and 95 percent during 50-year period). (Reprinted with permission from N. C. Donovan, B. A. Bolt, and R. V. Whitman, "Development of Expectancy Maps and Risk Analysis," ASCE, Journal of the Structural Division, Vol 104, No. St 8 (1978), pp 1179 - 1192.

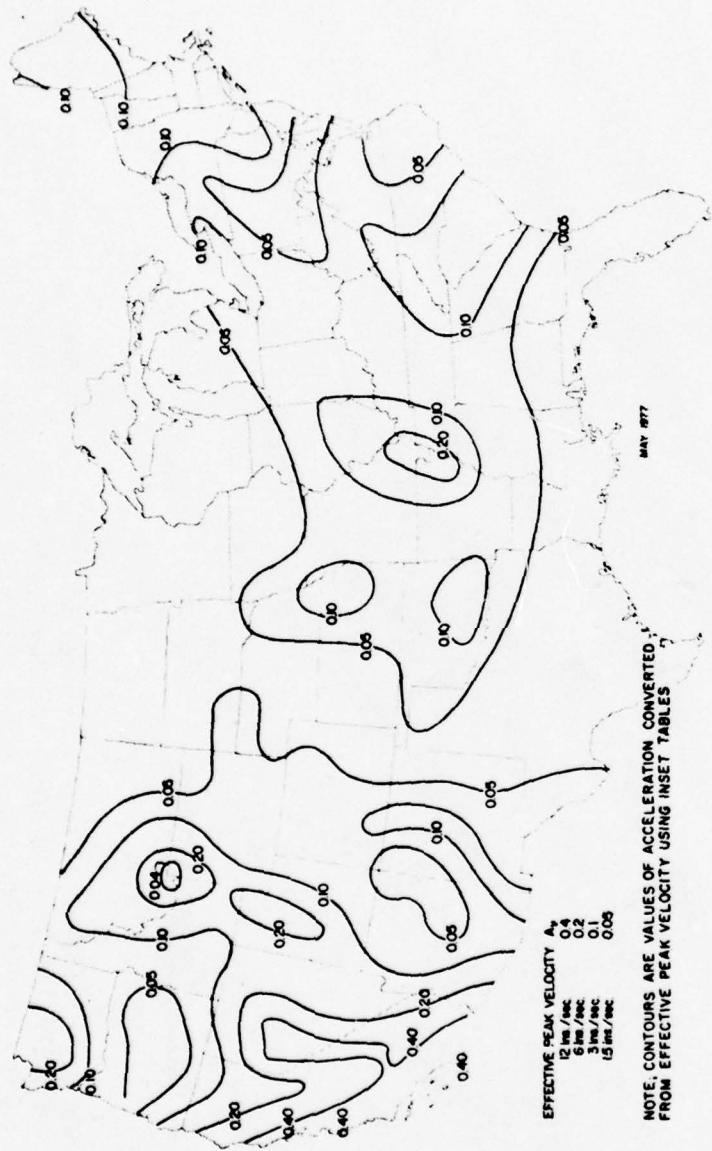

Figure 9. Contour map of effective peak velocity-related acceleration (EPV) for 40 contiguous states. (Contours represent values based on velocity but have been expressed equivalent to acceleration for use in developing lateral design forces). (Reprinted with permission from N. C. Donovan, B. A. Bolt, and R. V. Whitman, "Development of Expectancy Maps and Risk Analysis," ASCE, Journal of the Structural Division, Vol 104, No. St 8 (1978), pp 1179-1192.

In addition, it has been shown that hydrodynamic forces resulting from the vertical component of earthquake ground motions are comparable to those caused by horizontal earthquake ground motions for reservoirs of moderate depth, but much larger for small depths.

Thus, the earthquake factor is also subject to significant bias and uncertainty.

Bias and Uncertainty in the Horizontal Force Model

With the exception of wave, ice, wind, and horizontal silt pressure loading, the horizontal force model provides a reasonable representation of the true horizontal forces acting on the dam when the appropriate corrective factors are introduced into the equations and earthquake loadings are neglected. The bias introduced by neglecting the wave, ice, wind, and horizontal silt pressure would be unconservative; therefore, a corrective factor greater than 1 should be included to offset this systematic bias. The bias and uncertainty can only be assigned after proper consideration is given to the magnitude of the error and its potential variability.

Sliding Resistance Model

Equations for Mean and Uncertainty

The sliding resistance, Q , is a function of the unit shear strength at no normal load (cohesion), the angle of internal friction on the potential failure surface, and the vertical forces acting on the dam, including uplift, as expressed in Eq 3. Thus, in computing the sliding resistance, the major variables are s , ϕ , H_1 , H_2 , and K ; thus corrective factors N_s , N_ϕ , N_{H_1} , N_{H_2} , N_K , respectively, and N_q must be introduced into Eq 3 to obtain the mean value of the total sliding resistance force, Q . This substitution yields

$$Q = N_q \left[\sum \left\{ W_0 + N_{H_1} \gamma_w L_1 (H_1 - H_3) + 1/2 \gamma_w H_3 + 1/2 N_{H_2}^2 \gamma_w H_2^2 \tan \theta \right. \right. \\ \left. \left. - \gamma_w L [N_{H_2} H_2 + 1/2 N_K K (N_{H_1} H_1 - N_{H_2} H_2)] \right\} N_\phi \tan \phi + N_s s A \right] \quad [\text{Eq 26}]$$

The total uncertainty associated with Q can be evaluated through Eq 21. Again, if only H_1 and H_2 are assumed to be correlated variables, the total uncertainty becomes

$$\begin{aligned}
\Omega_Q = & \Omega_q^2 + \frac{N^2}{Q^2} \left[[\gamma_w(L_1 - KL)\tan\phi]^2 N_{H_1}^2 H_1^2 \Omega_{H_1}^2 + [(\gamma_w H_2 \tan\theta'' - \gamma_w L \right. \\
& + 1/2\gamma_w LK)\tan\phi]^2 N_{H_2}^2 H_2^2 \Omega_{H_2}^2 + L^2 N_S^2 \Omega_S^2 + [1/2\gamma_w(H_1 - H_2)]^2 \\
& \cdot N_K^2 \Omega_K^2 + \left\{ W_0 + \gamma_w L_1(H_1 - H_2) + 1/2\gamma_w L_1 H_3 - 1/2\gamma_w H_2^2 \tan\theta'' \right. \\
& \left. - \gamma_w L[H_2 + 1/2K(H_1 - H_2)\sec^2\phi] \right\}^2 N_\phi^2 \Omega_\phi^2 + [\gamma_w(L_1 - KL)\tan\phi] \\
& \cdot [(\gamma_w H_2 \tan\theta'' - \gamma_w L + 1/2\gamma_w LK)\tan\phi] \rho_{H_1 H_2} N_{H_1} N_{H_2} H_1 H_2 \Omega_{H_1} \Omega_{H_2} \left. \right] \quad [\text{Eq 27}]
\end{aligned}$$

Bias and Uncertainty of the Principal Variables

Shear resistance within a foundation and between a dam and its foundation depends on the cohesion and the angle of internal friction in the foundation and the bond between the concrete and foundation at the base of the dam. Traditionally, the shear resistance has been expressed as varying linearly with respect to the normal load according to the Coulomb equation, the variation of shear resistance versus normal load being determined by laboratory tests and/or in-situ tests. The in-situ rock, however, will invariably contain joints or other types of geological discontinuities which may be spaced from just a few inches to several feet apart. Moreover, a dam will usually stress a mass of rock large enough to include several of these discontinuities. Laboratory tests, on the other hand, are performed on intact rock cores containing no discontinuities (or at most a single joint). In addition, the rock cores used in the laboratory have been removed from their in-situ environment, i.e., the moisture conditions may change, the confining pressure has been altered, and the procedures of sampling may have degraded the quality of the sample. A scale effect may be introduced because of the size of the sample tested, and the results may also be sensitive to the rate of testing.

In-situ testing may provide a better picture of the quality of the rock, but it is still indicative rather than precise. Each test provides information relative to one small area; and, in general, the tests are done quickly so they are not representative of the behavior of the foundation under long term conditions.

Shear Strength (Cohesion). The pattern of joints, shear zones, and faults in a rock mass make the shear strength of rock highly anisotropic. When the direction of loading is such that the particular failure surfaces must cut across the structural features, the shear strength will approach that of the intact rock. However, when the direction of loading is parallel or subparallel to the structural features, the shear strength is governed by the shearing resistance along the rock surfaces of the discontinuity; and the effective shear strength will be reduced to a value much below the intact rock strength. This latter case is generally recognized as being critical in evaluating the sliding resistance of gravity dams.

The shearing resistance of rocks has been shown to exhibit both a peak shear strength and a residual strength as illustrated in Figure 10.⁷ In the shearing process, the shearing strength along the discontinuity reaches a maximum at some small value of displacement where fracture occurs. Thereafter, the shear strength gradually decreases with continuing displacements until finally at large displacement, the shear strength approaches asymptotically the residual strength. When more failure envelopes are drawn through the maximum and minimum values of shear strength obtained for specimens under different normal loads, N , the results may be similar to those shown in Figure 11. The vertical distance between the two envelopes indicates the reduction in shear strength by continued displacement. Note, also, that the residual strength envelope does not show a cohesion intercept and can be described uniquely by the angle of residual sliding reaction. Thus, the shearing resistance along a discontinuity in the field at a given value of normal load is dependent on the magnitude of the prior relative displacements which have occurred between the rock surfaces. When cohesion is taken into account in the design, it is customary to adopt values $1/3$ to $1/5$ of the apparent cohesion indicated by representative samples.⁸

Angle of Internal Friction. Typical peak and residual angles of internal friction for several rock types are presented in Table 3. As a result of this variation in the peak and residual angle of internal friction, the coefficient of friction ($\tan\phi$) along the failure plane can vary by a factor ranging between 1 and 2.

Uplift. A dam is subjected to water pressure, not only on exposed faces but also on its base. The pressure on the base (uplift) reduces the effective weight of the dam and, consequently, affects the sliding resistance of the dam. The intensity of the hydrostatic pressure and the area upon which the pressure acts have been the subject of

⁷ K. G. Stagg and O. C. Zienkiewicz, Rock Mechanics in Engineering Practice (John Wiley, 1968).

⁸ "Advances in Rock Mechanics," Proceedings of the Third Congress of the International Society for Rock Mechanics, Vol I, Part A (National Academy of Sciences, 1977).

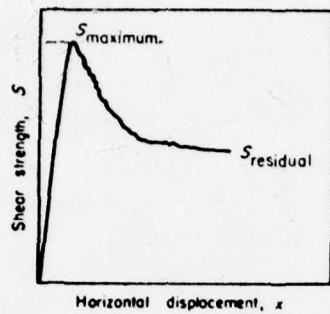

Figure 10. Shear strength versus horizontal displacement showing maximum and residual stresses. (Reprinted with permission from K. G. Stagg and O. C. Zienkiewicz, Rock Mechanics in Engineering Practice [John Wiley, 1968]).

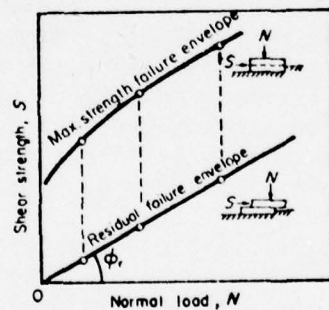

Figure 11. Maximum strength and residual failure envelope for initially intact specimens. (Reprinted with permission from K. G. Stagg and O. C. Zienkiewicz, Rock Mechanics in Engineering Practice [John Wiley, 1968]).

discussion in the past; however, today it is accepted design practice to assume the pressure acts on the full area of the base.

It is also accepted design practice to adopt a distribution of uplift pressure as shown in Figure 2, the value of K being selected after thorough consideration of the porosity of the foundation rock, the existence of joints and cracks therein, and the effectiveness of the drains. Based on experience, the U.S. Bureau of Reclamation normally uses a value of $K = 0.33$; the Tennessee Valley Authority has used 0.25; while the Corps of Engineers uses values between 0.25 and 0.50, depending on what is considered appropriate for the site.⁹

In summary, significant bias and uncertainty is associated with selection of the cohesion, angle of internal friction, and uplift. In addition, additional effects that were not discussed may increase this bias and uncertainty, such as rate of testing and sample size.

Bias and Uncertainty in the Sliding Resistance Model

The relationship for the sliding resistance neglects the effects of vertical earthquake acceleration, which is typically taken as two-thirds of the horizontal earthquake acceleration for design purposes. The gross effect of the vertical acceleration is to reduce the effective normal force acting on the interface at the base of the dam and thus reduce the sliding resistance.

Table 3

Maximum and Residual Angles of Internal Friction
(From K. G. Stagg and O. C. Zienkiewicz, Rock Mechanics in Engineering Practice (John Wiley, 1968).

<u>Rock Type</u>	<u>Maximum</u> ϕ (deg)	<u>Residual</u> ϕ (deg)
Sandstone	48-50	25-34
Limestone	37-58	33-37
Quartz Monzonite	56	32

⁹ H. H. Thomas, The Engineering of Large Dams, Part I (John Wiley, 1976), p 257.

Moreover, since the shear stress in the foundation of dams is usually not distributed uniformly along the potential failure surfaces, progressive failure may occur. This failure consists of mobilization of the peak shear strength in certain zones of the failure surface, while other zones have fractured and the shear strength is gradually decreasing. Within the framework of present knowledge, it is not possible to accurately calculate the maximum shearing resistance that may be developed during progressive collapse; however, it is possible to bound the problem. An upper limit corresponds to the mobilization of the peak shear strength of the material over the potential failure surface, and the lower limit corresponds to the mobilization of the residual shear strength. For reasons of safety, the lower limit is usually taken as the strength along the potential rupture surface.

Foundation Pressure Model

Equations for Mean and Uncertainty

The maximum foundation pressure, including uplift, may be obtained from Eq 14. By inspection, the foundation pressure is a function of the variables H_1 , H_2 , α , C , and K . Introducing the appropriate corrective factors and dropping the subscripts and superscripts associated with P_i yields

$$\begin{aligned}
 P = N_P \left[\left\{ W_0 + \gamma_w L (N_{H_1} H_1 - H_3) + 1/2 \gamma_w H_3 + 1/2 N_{H_2}^2 \gamma_w H_2^2 \tan \theta'' \right. \right. \\
 \left. \left. - \gamma_w L [N_{H_2} H_2 + 1/2 N_K K (N_{H_1} H_1 - N_{H_2} H_2)] \right\} (1/L) \right. \\
 \left. + \left\{ [4/15 N_\alpha N_C N_{H_1}^3 \alpha C H_1^3 + 1/6 \gamma_w N_{H_1}^3 H_1^3 - 1/6 \gamma_w N_{H_2}^3 H_2^3 \right. \right. \\
 \left. \left. + N_\alpha \alpha \gamma_C (1/6 L_1 H_3^2 + 1/2 L_2 H_0^2 + 1/6 L_3 H_4^2) - 1/6 \gamma_w L_1 (N_{H_1} H_1 - H_3) (L - L_1) \right. \right. \\
 \left. \left. - 1/2 \gamma_w L_1 H_3 (1/2 L - 1/3 L_1) - 1/2 \gamma_C L_1 H_3 (1/2 L - 2/3 L_1) - \gamma_C L_2 H_0 (1/2 L \right. \right. \\
 \left. \left. - L_1 - 1/2 L_2) + 1/2 \gamma_C L_3 H_4 (1/2 L - 2/3 L_3) + 1/2 \gamma_C N_{H_2}^2 H_2^2 \tan \theta'' \right. \right. \\
 \left. \left. \cdot (1/2 L - 1/3 N_{H_2} H_2 \tan \theta') + 1/12 \gamma_w N_K K (N_{H_1} H_1 - N_{H_2} H_2) L^2 \right\} (1/L^2) \right. \\
 \left. + \gamma_w N_{H_2} H_2 \right\} \sec^2 \theta'' - \gamma_w N_{H_2} H_2 (\sin \theta'' + \cos \theta'') \left. \right]
 \end{aligned}
 \tag{Eq 28}$$

The total uncertainty associated with P can be evaluated through Eq 21. To improve the tractability of the derivation, the expressions for the derivatives, evaluated at their mean values, are included. Again, the subscripts and superscripts associated with P have been dropped.

$$\frac{\partial P}{\partial H_1} = \left[\gamma_w (L_1 - 1/2KL)(1/L) + 6[12/15C\alpha H_1^2 + 1/2\gamma_w H_1^2 - 1/2\gamma_w L_1(L-L_1) - 1/6\gamma_w KL^2](1/L^2) \right] \sec^2 \theta'' = B_1$$

$$\begin{aligned} \frac{\partial P}{\partial H_2} = & \left[\gamma_w (-L_1 + H_2 \tan \theta'' - L + 1/2K)(1/L) + 6\gamma_w [-1/2H_2^2 + 1/2LH_2 \tan \theta'' - 1/2H_2^2 \tan \theta'' - 1/6KL^2](1/L^2) + \gamma_w \right] \sec^2 \theta'' - \gamma_w (\sin \theta'' \\ & + \cos \theta'') \tan^2 \theta'' = B_2 \end{aligned} \quad [\text{Eq 29}]$$

$$\frac{\partial P}{\partial C} = 6(4/15\alpha H_1^3)(1/L^2) = B_3$$

$$\frac{\partial P}{\partial K} = -3/2\gamma_w (H_1 - H_2) = B_4$$

$$\frac{\partial P}{\partial \alpha} = 6[4/15CH_1^3 + \gamma_c (1/6L_1 H_3^2 + 1/2L_2 H_0^2 + 1/6L_3 H_4^2)](1/L^2) = B_5$$

Therefore, the total uncertainty of the maximum foundation pressure becomes

$$\begin{aligned} \Omega_p^2 = & \Omega_p^2 + \frac{N^2}{p^2} [B_1^2 N_{H_1}^2 H_1^2 \Omega_{H_1}^2 + B_2^2 N_{H_2}^2 H_2^2 \Omega_{H_2}^2 + B_3^2 N_C^2 C^2 \Omega_C^2 \\ & + B_4^2 N_K^2 K^2 \Omega_K^2 + B_5^2 N_\alpha^2 \alpha^2 \Omega_\alpha^2] \end{aligned} \quad [\text{Eq 30}]$$

Bias and Uncertainty of the Principal Variables

The foundation pressure is a function of the random variables previously discussed; consequently, the discussions regarding the bias and uncertainty of each of these random variables is also applicable to the foundation pressure.

Bias and Uncertainty of the Foundation Pressure Model

In the gravity method of analysis, each section of the dam is assumed to act independently, and the loads are transmitted to the foundation by cantilever action. In this method, the effects of elasticity of the dam, as well as the foundation, are ignored. In reality, both the dam and its foundation are elastic, and the effects of this elasticity will cause the foundation pressure to depart from the linear distribution inherently assumed through the use of Eqs 11 and 12.¹⁰

For example, Figure 12 illustrates the foundation pressures measured under the Shasta Dam, in January 1954 at the time the reservoir was nearly full. The measured maximum stress was 4.1 MPa at a point near the center of the base. Near the downstream face, the foundation pressure reduces to about 1 MPa, which indicates the downstream third of the concrete dam was carrying a relatively minor part of the load. The maximum measured shearing stress occurred near the downstream face in the area of minimum vertical pressure. Measurements at Grand Coulee Dam show a quite different pattern (Figure 13). Thus, there may be considerable bias and uncertainty in the foundation pressures model.

Foundation Compressive Strength Model

Equations for Mean and Uncertainty

Usually the compressive strength of the foundation material, σ , will be determined from laboratory tests on small samples. However, mature judgment must supplement the laboratory test results in order to estimate the compressive strength of the in-situ foundation material, i.e., evaluate the effects of lateral pressures, cracks, and joints, solubility, etc. Thus, to estimate the mean compressive strength of the foundation material, corrective factors N_σ and N_u are introduced such that the mean value of the compressive strength becomes

$$U = N_u(N_\sigma\sigma) \quad [\text{Eq 31}]$$

¹⁰ H. H. Thomas, The Engineering of Large Dams, Part I (John Wiley, 1976), p 257.

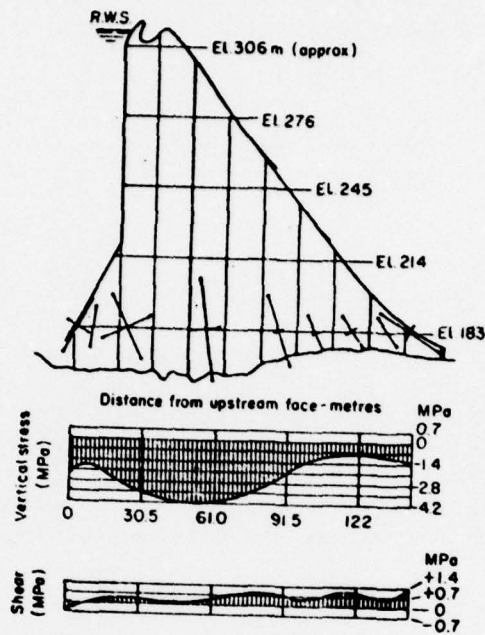

Figure 12. Foundation pressure measurements under Shasta Dam. (Reprinted with permission from H. H. Thomas, The Engineering of Large Dams, Part I (John Wiley, 1976), p 257.

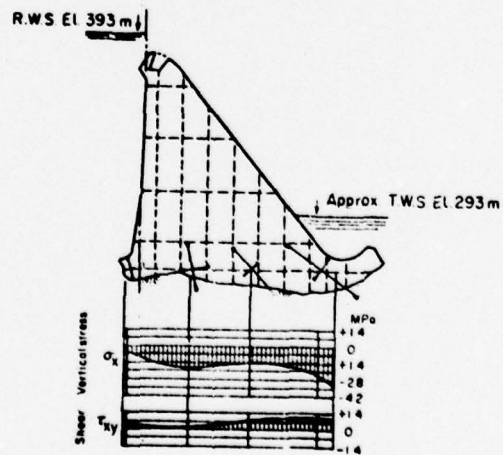

Figure 13. Foundation pressure measurements under Grand Coulee Dam. (Reprinted with permission from H. H. Thomas, The Engineering of Large Dams, Part I (John Wiley, 1976), p 257.

Since the mean value is independent of the other major variables, the total uncertainty associated with it becomes

$$\Omega_u^2 = \Omega_u^2 + \frac{N_u^2}{U^2} [N_\sigma^2 \Omega_\sigma^2] \quad [\text{Eq 32}]$$

Uncertainty in Foundation Compressive Strength

The strength of the foundations on which dams are founded varies from solid rock, which is much stronger than concrete, through all stages of decomposed and disintegrated rock. Yet, the compressive strength of the foundation rock is very important in determining the base width of the dam. Normally, the maximum allowable compressive stress in the foundations is 25 percent and 80 percent of the foundation compressive strength for normal and extreme loading conditions, respectively.¹¹

Bias and Uncertainty of Compressive Strength Model

If a proper corrective factor is applied to the foundation compressive strength, then the bias associated with the model is unity. The uncertainty is the confidence one has that all corrective factors are accounted for properly.

¹¹ A. R. Golze, Handbook of Dam Engineering (Van Nostrand Reinhold Company, 1977).

5 SIMPLE APPLICATIONS

General

In the interest of simplicity and for the lack of design information and data for an actual dam, examples of two moderately low gravity dams designed in accordance with conventional design procedures were selected for analysis to illustrate the probabilistic concepts developed in the preceding section. These example designs, which are contained in Engineering for Dams, were designed to have a minimum shear-friction safety factor of 5.0 and an overturning safety factor of 1.0.¹² In one example, a 200-ft nonoverflow gravity dam was designed considering only water loadings; in the other example, an identical dam was designed considering both water and earthquake loadings. The primary objectives of the analyses in this chapter are to estimate the probability of failure of the dams with respect to sliding and overturning and to develop an insight into the effects of various sources of uncertainty underlying the design parameters on the safety of the dam.

200-Ft Nonoverflow Gravity Dam

The cross section of the 200-ft nonoverflow gravity dam, which was designed to resist only water loadings, is shown in Figure 14 together with the design specifications and conditions.

Since the statistics of the principal random variables were not given in the cited example, it was necessary to estimate reasonable values for the lower and upper bounds of the mean, to assume some appropriate distributions for the mean over its range, and to compute the mean and coefficient of variation by standard statistical methods. Formulas for computing the mean and coefficient of variation for some simple distributions are presented in Table 4.¹³ Next, estimates for the corrective factor associated with each variable were developed, based on the considerations discussed in the preceding section. A reasonable value was assigned to each of the corrective factors, then a series of lower and upper values was established in an effort to bound the likely corrective factors. The coefficient of variation for the corrective factors was assigned a value of 0.2, based on intuition and professional judgment. Finally, estimates of the bias associated with the horizontal force, sliding resistance, foundation pressure, and foundation compressive strength models were developed. A mean value of 1.05 was as-

¹²W. P. Creager, J. D. Justin, and J. Hinds, Engineering for Dams (John Wiley, 1945).

¹³M. S. Yuceman, W. H. Tank, and A. H-S. Ang, A Probabilistic Study of Safety and Design of Earth Slopes, Civil Engineering Studies Structural Research Series No. 402 (University of Illinois, 1973).

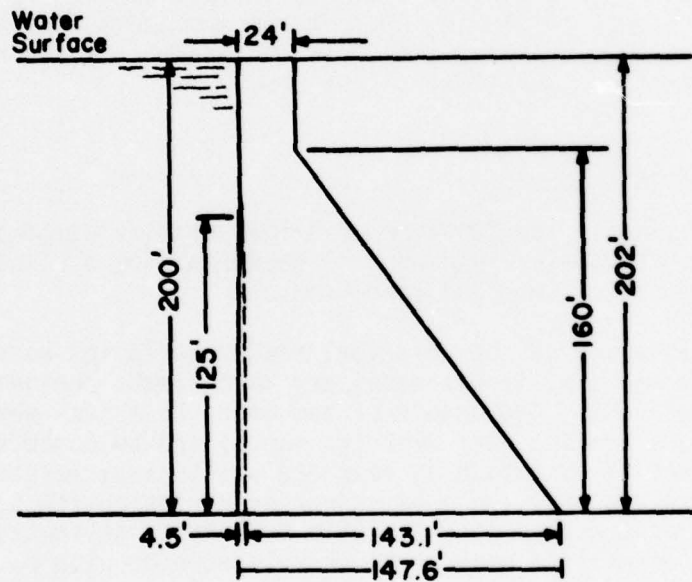



Maximum Depth of Water to Be Retained = 200 ft
 Depth of Tailwater = 0
 Crest Width = 24 ft
 Spill Way Crest to Maximum Water Surface = 10
 Weight of Concrete = 150 pcf
 Angle of Internal Friction for Foundation Material = 36.9°
 Ultimate Shear Resistance of Foundation = 800 psi
 Maximum Allowable Inclined Stress = 60 ksf
 Weight of Water = 62.5 pcf
 Uplift Intensity Factor = 0.5

Figure 14. 200-ft nonoverflow gravity dam.

Table 4

Mean and Coefficient of Variation of N_j Corresponding to Different Distributions Assumed Over Its Range. From M. S. Yuceman, W. H. Tank, and A. H-S. Ang, A Probabilistic Study of Safety and Design of Earth Slopes, Civil Engineering Studies Structural Research Series No. 402 (University of Illinois, 1973).

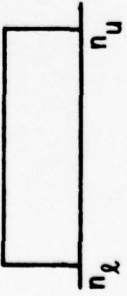
Distribution	Symbol	\bar{N}_j	Δ_j
	Triangular Type 1 (TT1)	$0.333(2n_l + n_u)$	$0.707 \frac{n_u - n_l}{2n_l + n_u}$
	Triangular Type 2 (TT2)	$0.333(n_l + 2n_u)$	$0.707 \frac{n_u - n_l}{n_l + 2n_u}$
	Triangular Type 3 (TT3)	$0.500(n_l + n_u)$	$0.408 \frac{n_u - n_l}{n_l + n_u}$
	Uniform (Rectangular) (Un.)	$0.500(n_l + n_u)$	$0.578 \frac{n_u - n_l}{n_l + n_u}$

n_l : lower bound of N_j

n_u : upper bound of N_j

signed to the horizontal force because factors such as wind, wave, ice, and silt pressure were neglected in computing the horizontal force acting on the dam. A mean value of 0.90 was assigned to the sliding resistance in partial recognition of potential progressive failure. In the absence of more definitive data, a mean value of 1.0 was assigned to both the foundation pressure and compressive strength. The coefficient of variation for all the bias factors was assigned a value of 0.2. The mean values and coefficients of variations for the principal variables, corrective factors, and bias are summarized in Table 5.

In the analysis, the mean value of each corrective factor was systematically varied, and the probabilities of sliding and overturning failures were computed. For example, in computing the probability of sliding failure, the corrective factor for each of the four variables influencing a sliding failure was systematically varied while the corrective factors for the other variables were assigned their intermediate mean value. That is, when the corrective factor for a variable such as the reservoir water elevation was varied, the corrective factors for the angle of internal friction, hydrostatic pressure intensity factor, and foundation shear strength were 1.5, 1.0, and 2.0, respectively. In this fashion, the effect of a particular parameter could be isolated to the maximum extent. A similar procedure was followed in computing the probability of an overturning failure.

The probability of sliding failure of the 200-ft nonoverflow dam was less than 10^{-6} for all cases and outside the range of practical interest. Thus, detailed results are not included. On the other hand, the probability of overturning failure was greater than 10^{-5} as illustrated in the plots of probability of overturning failure versus the corrective factors for reservoir water elevation, hydrostatic pressure, intensity, and foundation compressive strength shown in Figures 15, 16, and 17, respectively. While the probability of overturning failure might initially appear to be insensitive to the corrective factor for reservoir water elevation, it should be noted that the corrective factor is only varied through a range of plus and minus 4 percent, and this small change results in nearly an order of magnitude difference in the computed probability of overturning failure. The corrective factor for hydrostatic pressure intensity has virtually no effect on the probability of overturning failure for the range considered. As one would expect, the corrective factor for foundation compressive strength has a great effect on the probability of overturning failure. Increasing the corrective factor from 1.0 to 4.0 decreases the probability of overturning failure from nearly 10^{-1} to 10^{-5} , i.e., about four orders of magnitude. Thus, the corrective factor for foundation compressive strength should be established with care in any analysis of an actual dam.

Table 5
 Mean and Coefficient at Variation for Random Variables and Their Corrective Factors

Random Variable	Corrective Factor	
	Mean	C.O.V
Reservoir water elevation	196.7 ft	0.01
Angle of internal friction	36.9°	0.05
Uplift intensity factor	0.5	0.15
Foundation shear strength	115.2 ksf	0.3
Foundation compressive strength	60.0 ksf	0.3
Horizontal force bias	1.05	0.2
Sliding resistance bias	0.90	0.2
Foundation pressure bias	1.0	0.2
Foundation compressive strength bias	1.0	0.2

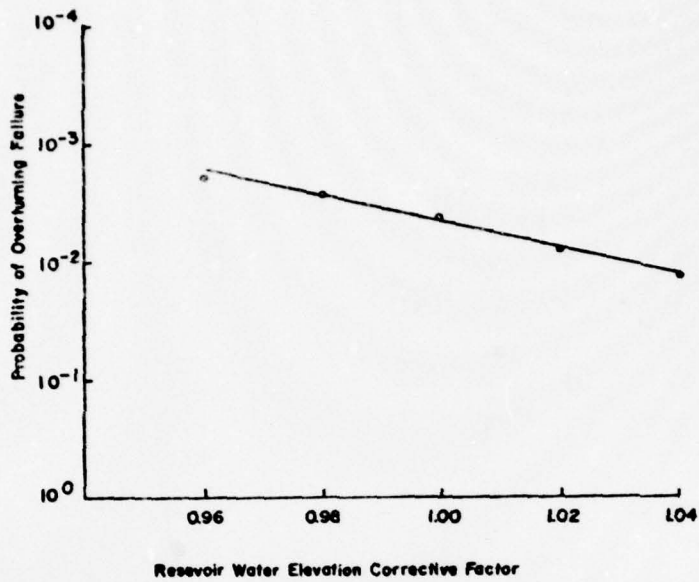

Figure 15. Probability of overturning failure vs. reservoir water elevation corrective factor.

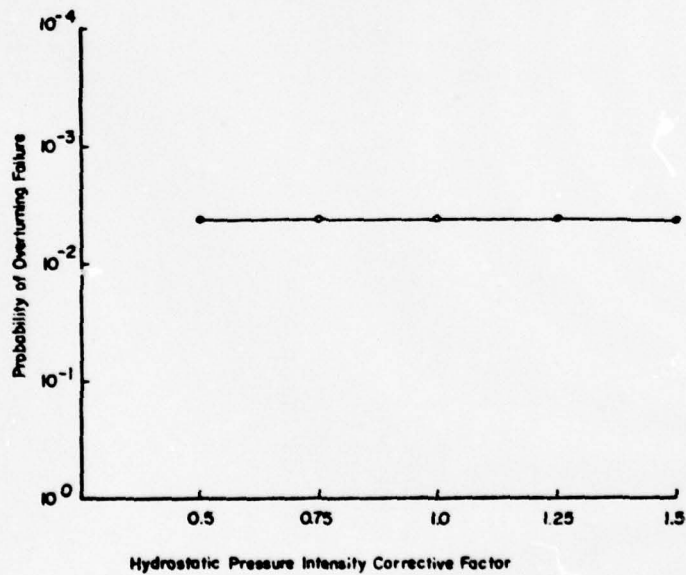

Figure 16. Probability of overturning failure vs. hydrostatic pressure intensity corrective factor.

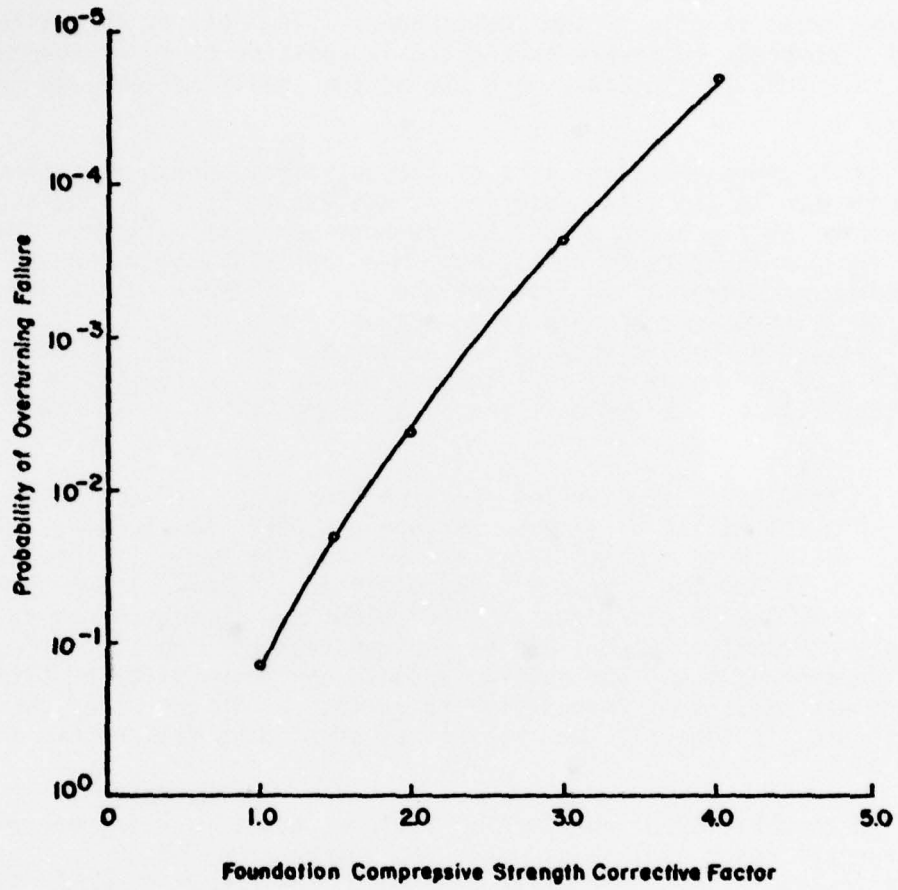

Figure 17. Probability of overturning failure vs. foundation compressive strength corrective factor.

200-Ft Nonoverflow Gravity Dam With Earthquake Loading

The cross section of the 200-ft nonoverflow gravity dam designed to resist a moderate to severe earthquake in addition to water loading is shown in Figure 18, together with the design specifications and conditions.

Again, since the statistics of the principal random variables were not presented in the cited example, it was necessary to follow a procedure similar to that employed in the previous application to develop means and coefficients of variation. However, statistics for the earthquake acceleration coefficient and the earthquake factor had to be included. These were assumed to have mean values of 0.1 and 51.7, respectively, and coefficients of variations 0.3 and 0.005, respectively. A summary of the means and coefficients of variation for the principal variables, corrective factors, and bias parameters is presented in Table 6.

For the 200-ft nonoverflow dam with both water and earthquake loadings, the probability of sliding failure was less than 10^{-5} for all cases. While these probabilities are outside the range of interest, an indication of how the computed probability of sliding failure varies with the earthquake acceleration coefficient and foundation shear strength corrective factors can be derived from Figures 19 and 20. With the exception of these corrective factors, the probability of sliding failure was relatively insensitive to variations in the other corrective factors and, in general, the probability of sliding failure was in the order of 10^{-9} .

The probability of overturning failure, however, was greater than 10^{-3} for all cases and, in general, was in the order of 10^{-2} . The effect of the various corrective factors on the computed probability of overturning failure can be observed in Figures 21 through 25. Variations in the foundation compressive strength and earthquake acceleration coefficient corrective factors produced the greatest impact on the computed probability of overturning failure. Thus, special care should be observed in assigning values for these corrective factors.

The results cited so far primarily illustrate the effects that variations in the corrective factor have on the probability of a sliding or overturning failure, i.e., the effects of varying the corrective factor uncertainty, bias, and bias uncertainty have not been investigated. To evaluate the effect that corrective factor uncertainty may have on the probability of failure, the analysis required to obtain the data presented in Figure 25 was repeated for a series of cases in which the corrective factor uncertainty was assigned values of 0, 0.1, 0.2, and 0.3. These results are summarized in Figure 26, and they indicate that corrective factor uncertainty becomes more significant as the magnitude of the corrective factor increases. Moreover, for the most likely range of foundation compressive strength corrective factor (2-4),

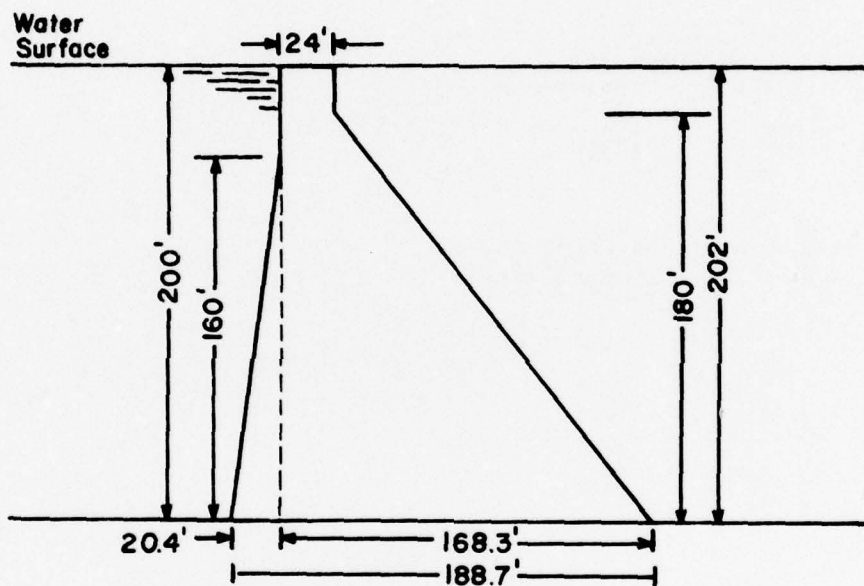

Maximum Depth of Water to Be Retained = 200 ft
 Depth of Tailwater = 0
 Crest Width = 24 ft
 Spill Way Crest to Maximum Water Surface = 10 ft
 Uplift Intensity Factor = 0.5
 Angle of Internal Friction for Foundation Material = 36.9°
 Ultimate Shear Resistance of Foundation = 115.2 ksf
 Maximum Allowable Inclined Stress = 60 ksf
 Ratio of Earthquake Acceleration to Gravity = 0.1
 Earthquake Factor = 51.7
 Weight of Concrete = 150 pcf
 Weight of Water = 62.5 pcf

Figure 18. 200-ft nonoverflow gravity dam with earthquake loading.

Table 6
 Mean and Coefficient of Variations for Random Variables and Their Corrective Factors

Random Variable	Corrective Factor	
	Mean	C.O.V
Reservoir water elevation	196.7 ft	0.01
Earthquake acceleration coefficient	0.1	0.3
Earthquake factor	51.7 ^o	0.005
Angle of internal friction	36.0 ^o	0.05
Uplift intensity factor	0.5	0.15
Foundation shear strength	112.5 ksf	0.3
Foundation compressive strength	60.0 ksf	0.3
Horizontal force bias	1.05	0.2
Sliding resistance bias	0.90	0.2
Foundation pressure bias	1.0	0.2
Foundation compressive strength bias	1.0	0.2

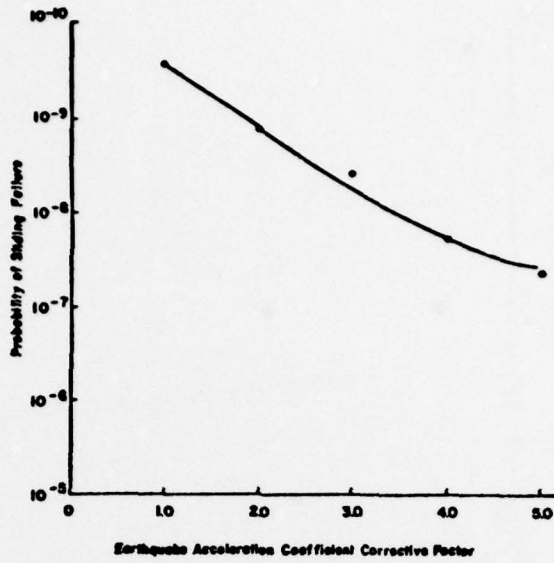

Figure 19. Probability of sliding failure vs. earthquake acceleration coefficient corrective factor.

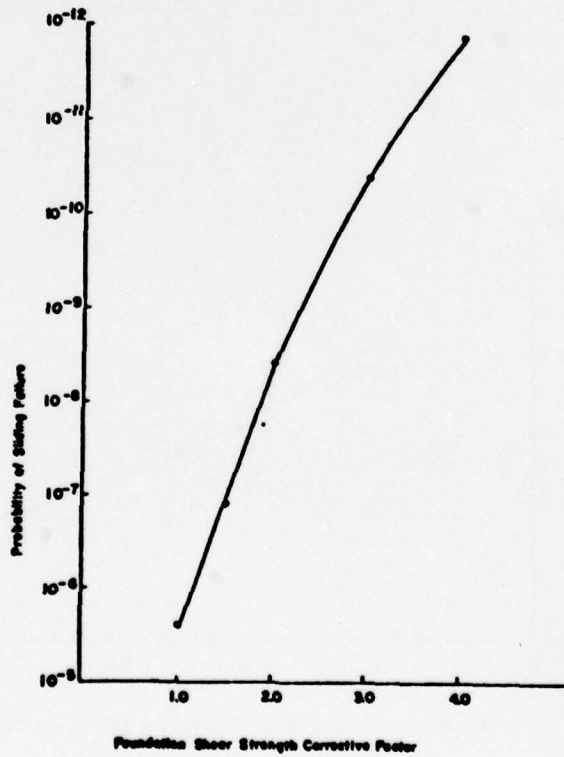

Figure 20. Probability of sliding failure vs. foundation shear strength corrective factor.

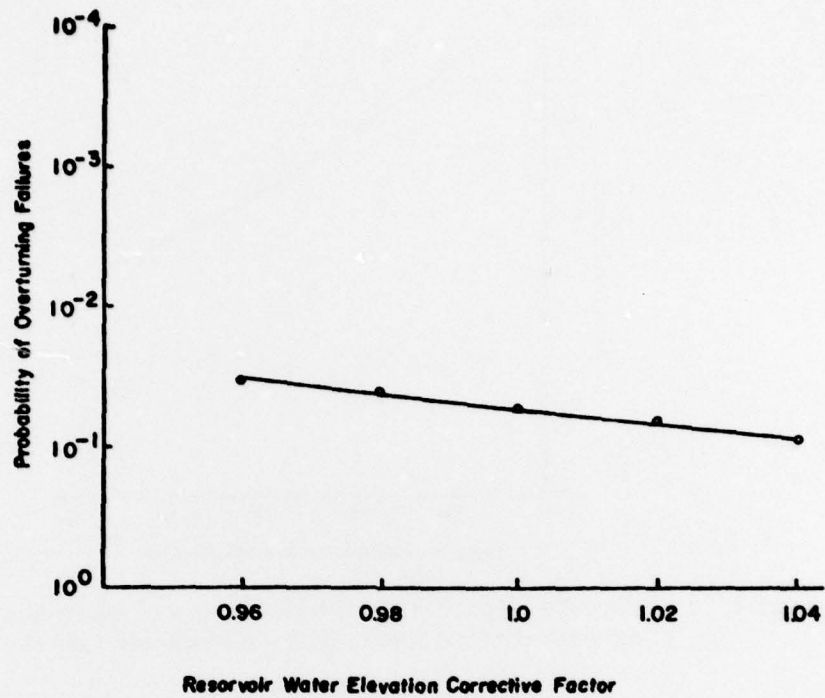

Figure 21. Probability of overturning failure vs. reservoir water elevation corrective factor.

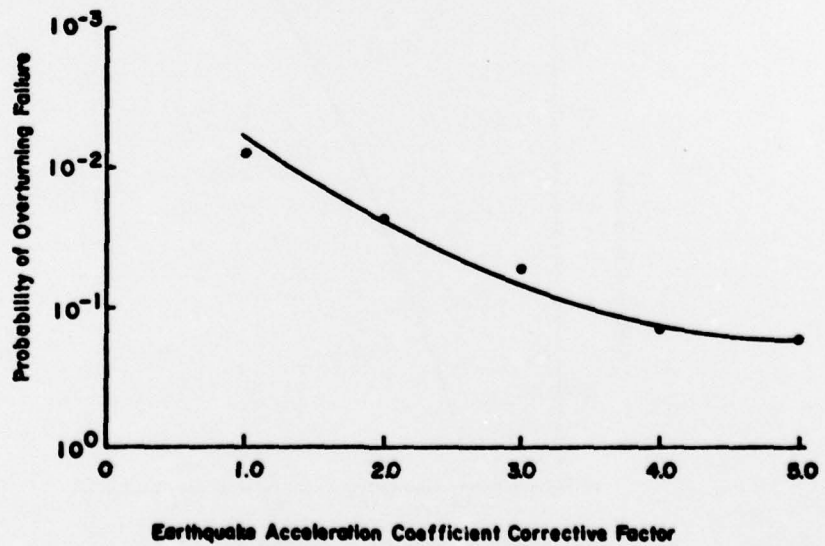
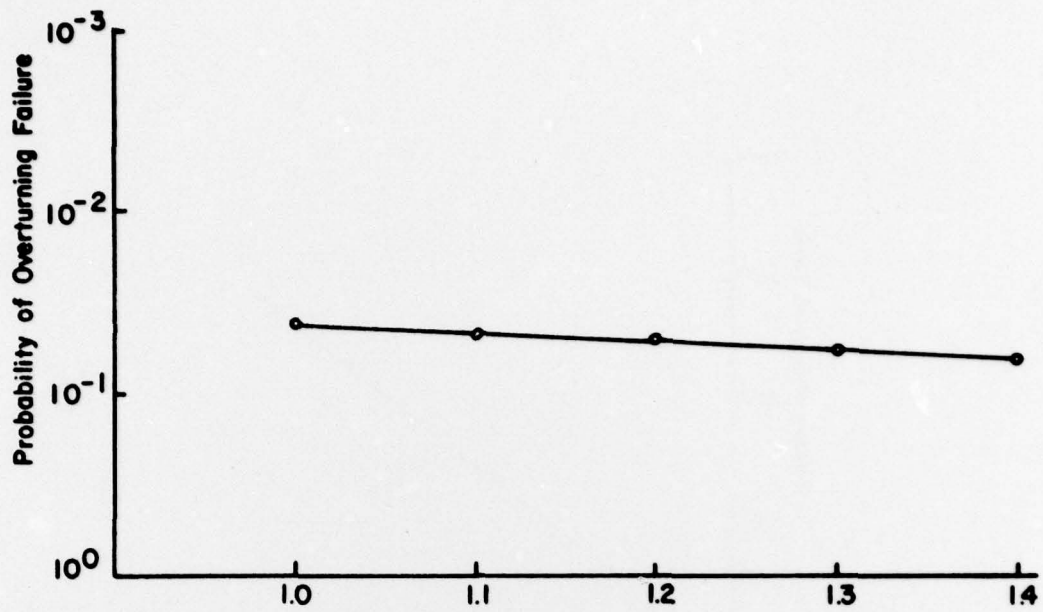
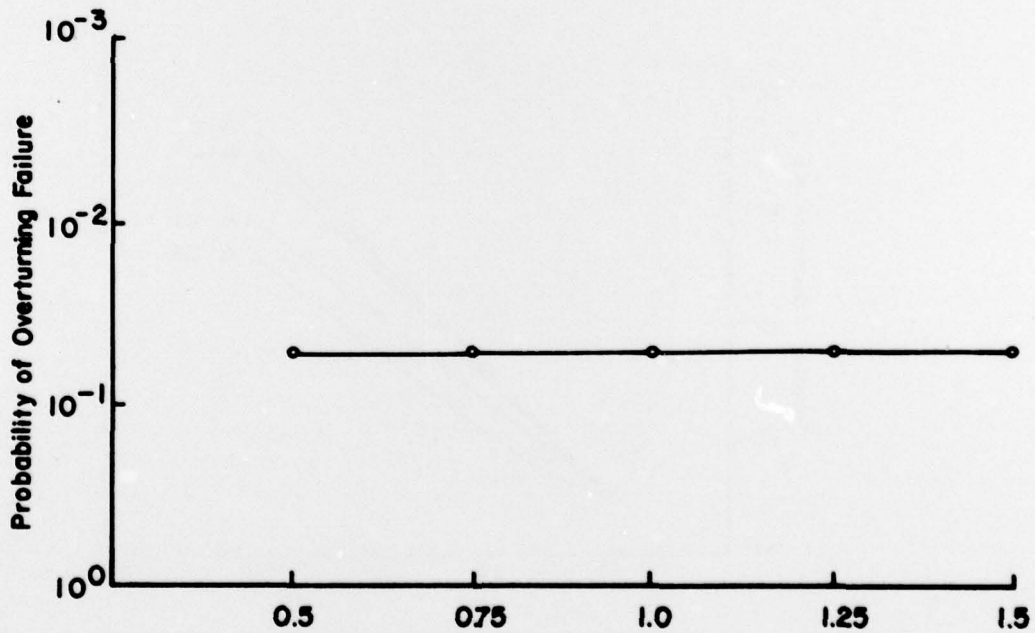

Figure 22. Probability of overturning failure vs. earthquake acceleration coefficient corrective factor.



Earthquake Factor Corrective Factor

Figure 23. Probability of overturning failure vs. earthquake factor corrective factor.



Hydrostatic Pressure Intensity Corrective Factor

Figure 24. Probability of overturning failure vs. hydrostatic pressure intensity corrective factor.

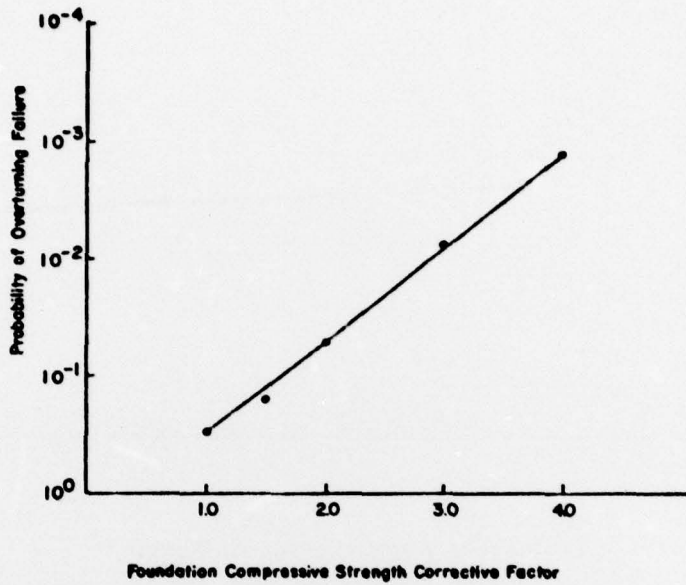

Figure 25. Probability of overturning failure vs. foundation compressive strength corrective factor.

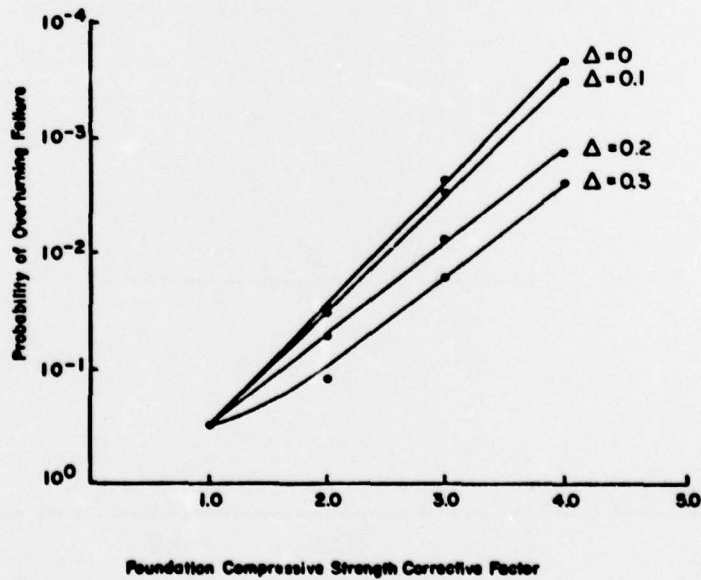

Figure 26. Effect of corrective factor uncertainty.

the difference between assigning a value of 0 or 0.3 to the corrective factor uncertainty will change the results by about an order of magnitude.

Likewise, to evaluate the effect that variations in the bias may have on the probability of failure, a similar analysis was repeated for a series of cases in which the bias for the foundation pressure and the foundation compressive strength were jointly assigned values of 0.8, 1.0, 1.2, and 1.4. While the mean values for the load and resistance varied in accordance with the assigned values of bias, the computed probability of overturning did not depart from the results presented in Figure 25 in sufficient magnitude to warrant plotting. Thus, establishing the proper ratio between the bias for the foundation pressure and the foundation compressive strength is probably more important than knowing the precise magnitude of the bias.

Finally, a similar analysis was repeated to evaluate the effect of bias uncertainty. Values of 0, 0.1, 0.2, and 0.3 were assigned to the bias uncertainty, and as before, the probability of overturning failure was computed. These results are presented in Figure 27 and, in general, they are similar to the results presented in Figure 26. However, these results indicate that the bias uncertainty has a slightly greater effect on the probability of failure than the corrective factor uncertainty. Thus, as larger values are assigned to the corrective factors, greater care should be observed first in assigning values to the bias uncertainty and second in assigning values to the corrective factor uncertainty.

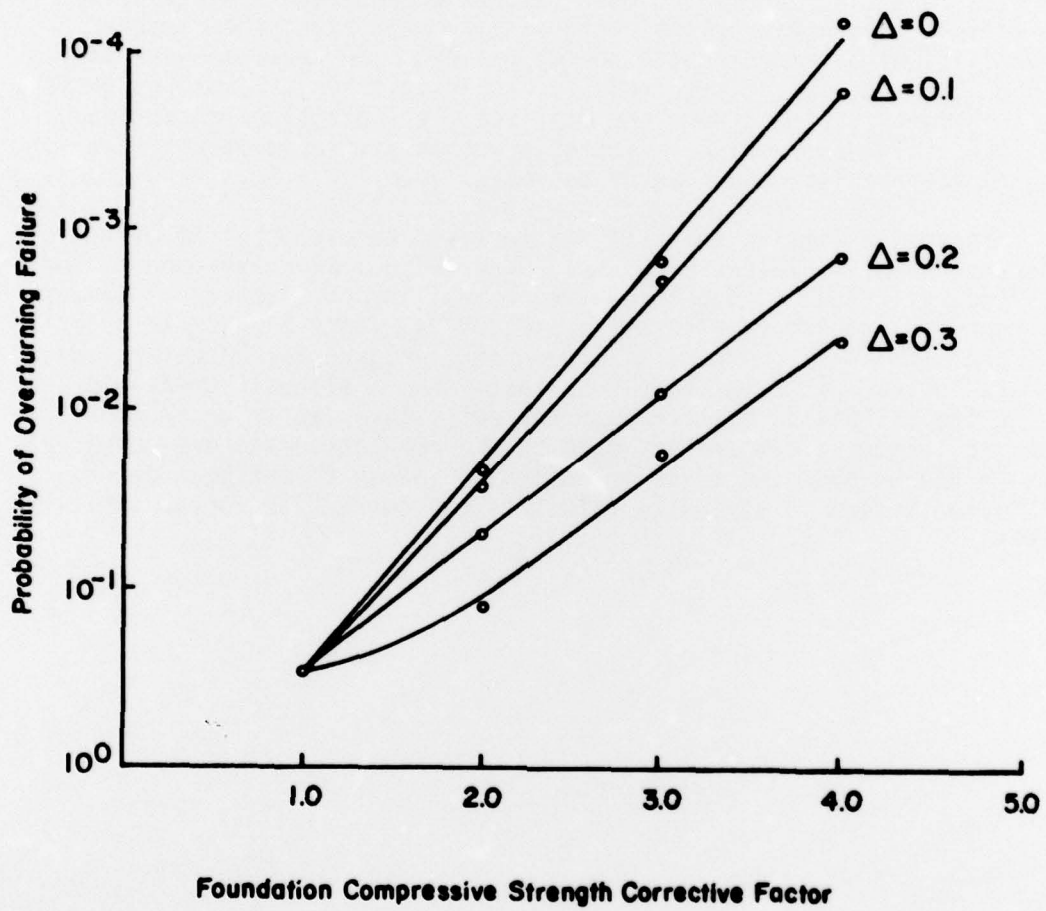

Figure 27. Effect of bias uncertainty.

6 PRELIMINARY CONCLUSIONS AND RECOMMENDATIONS

Conclusions

Concepts and methods of probability, i.e., extended reliability theory, provide the proper basis for evaluating of the safety of dams. Moreover, implementation of these concepts and methods is within the current state of the art as illustrated by the probabilistic concept for concrete gravity dams summarized herein. With such formulations, the effects of different sources of uncertainty underlying the conventional design parameters can be systematically combined and analyzed in a manner suitable for a quantitative assessment of the safety of a dam with respect to various modes of failure. Such formulations also provide an improved basis for updating design criteria. Finally, it should be emphasized that the lack of statistical data is not a valid reason for rejecting probabilistic concepts and methods. Indeed, it is only through probabilistic models that the significance of objective information, or lack thereof, can be properly assessed and combined with engineering judgment to provide a quantitative assessment of the safety of a dam.

For the simple applications of the probabilistic concept for concrete gravity dam analysis presented herein, it was observed that:

1. The probability of sliding failure was most sensitive to the corrective factors assigned to the foundation shear strength and the earthquake acceleration coefficient. There was considerably less sensitivity associated with the other corrective factors.
2. The probability of overturning failure was most sensitive to the corrective factors assigned to the foundation compressive strength and the earthquake acceleration coefficient. The corrective factors assigned to reservoir water elevation and the earthquake factor produced considerably less sensitivity in the results, and the results were virtually insensitive to the hydrostatic pressure intensity corrective factor. The probability of overturning failure also became more sensitive as large values were assigned to the corrective factor for bias uncertainty and corrective factor uncertainty, with the bias uncertainty having a slightly greater effect. Moreover, establishing the proper ratio between the bias associated with the load and resistance models may be more important than determining the precise magnitude of the bias.
3. In any future application of this probabilistic concept for gravity dam analysis, special care should be exercised in assigning values to the corrective factors for the foundation shear strength, the foundation compressive strength, the earthquake acceleration coefficient, the ratio of the bias in the load and resistance models, and -- when the corrective factors are large -- the bias uncertainty and corrective factor uncertainty.

4. For the design example where only water loading was considered, the probability of sliding failure was less than 10^{-6} , and the probability of overturning failure was greater than 10^{-5} for the range of parameters considered.

5. For the design example where both water and earthquake loadings were considered, the probability of sliding failure was less than 10^{-5} and the probability of overturning failure was greater than 10^{-3} for the range of parameters considered.

Recommendations

The results to date illustrate that it is possible to quantify the safety of a dam in a probabilistic sense. However, the results and conclusions cited above should be viewed as preliminary until the concept can be discussed with Corps designers experienced in gravity dam design, and until the safety of a Corps dam can be analyzed in cooperation with Corps designers to provide a practical application for further evaluation of the probabilistic concept. Finally, the concept must be translated into a practical format that can be readily used by Corps design engineers.

REFERENCES

- "Advances in Rock Mechanics," Proceedings of the Third Congress of the International Society for Rock Mechanics, Vol I, Part A (National Academy of Sciences, 1977).
- Ang, A. H-S. and C. A. Cornell, "Reliability Bases of Structural Safety and Design," ASCE, Journal of the Structural Division, Vol 100, No. St 9 (1974), pp 1755-1769.
- Chakrabarti, P. and A. K. Chopra, "Earthquake Analysis of Gravity Dams Including Hydrodynamic Interaction," Earthquake Engineering and Structural Dynamics, Vol 2 (1973), pp 143-160.
- Creager, W. P., J. D. Justin, and J. Hinds, Engineering for Dams (John Wiley, 1945).
- Dam Safety Program in the Corps of Engineers, Report to the Federal Coordinating Council for Science, Engineering and Technology (U.S. Army Corps of Engineers, Office of the Chief of Engineers, 1977).
- Donovan, N. C., B. A. Bolt, and R. V. Whitman, "Development of Expectancy Maps and Risk Analysis," ASCE, Journal of the Structural Division, Vol 104, No. St 8 (1978), pp 1179-1192.
- EM 1110-2-2200, Gravity Dam Design (U.S. Army Corps of Engineers, 1958).
- ER 1110-2-1806, Earthquake Design and Analysis for Corps of Engineers Dams (U.S. Army Corps of Engineers, 1977).
- Golze, A. R., Handbook of Dam Engineering (Van Nostrand Reinhold Company, 1977).
- Stagg, K. G. and O. C. Zienkiewicz, Rock Mechanics in Engineering Practice (John Wiley, 1968).
- Thomas, H. H., The Engineering of Large Dams, Part I (John Wiley, 1976), p 257.
- Yuceman, M. S., W. H. Tank, and A. H-S. Ang, A Probabilistic Study of Safety and Design of Earth Slopes, Civil Engineering Studies Structural Research Series No. 402 (University of Illinois, 1973).

APPENDIX: LIST OF SYMBOLS

A	= area of base of the dam for a section of unit length
C	= earthquake factor (Figure 3)
F_{n_2}	= cumulative distribution function of n_2
ΣH	= summation of all horizontal forces acting on dam per unit length
H_0	= total height of dam section
H_1, H_2	= height of reservoir and tailwater, respectively
$H_3, H_4,$	= height of changes in section in the upstream and downstream faces of dam, respectively
I	= moment at inertia of a unit length of the base about its center of gravity
K	= hydrostatic pressure intensity factor
L	= total width of the dam at the base
L_1, L_2, L_3	= width of various sections of the dam
M_0	= overturning moment, including uplift moment, about the center of gravity of the base
m	= distance from the center of gravity of the base of the dam
N	= correction factor with mean \bar{N} and coefficient of variation Δ
P_1	= total reservoir water force per unit length
P_2	= total tailwater force per unit length
P_e	= total hydrodynamic force due to earthquake per unit length
P_0	= total inertial force due to earthquake per unit length
P_i', P_i''	= inclined pressure at the upstream and downstream faces, respectively
P_n', P_n''	= external normal unit pressures on upstream and downstream force of the dam, respectively

P_r', P_r''	= vertical pressure at the upstream and downstream faces, respectively
P_v', P_v''	= maximum vertical unit pressures on upstream and downstream faces of the dam, respectively
P_u', P_u''	= unit uplift pressures on the base of the dam on the upstream or downstream face of the dam, respectively
P_f	= probability of failure
Q	= sliding resistance of dam per unit length
R, S	= true random resistance and true random load (or load effects), respectively
\hat{R}, \hat{S}	= models of R and S
\bar{R}, \bar{S}	= mean values of \hat{R} and \hat{S}
s	= unit shearing stress along potential failure plane
S_{s-f}	= shear friction safety factor
t_e	= period of vibration of the earthquake
U	= compressive strength of the foundation material
ΣV	= summation of all vertical forces acting on dam, including uplift but excluding foundation reaction, per unit length
W_0	= total dead weight of the dam per unit length
W_1, W_2, W_3	= vertical weight of reservoir and tailwater component acting on dam per unit length
W_u	= total uplift force per unit length
X_i	= basic resistance or load variables
α	= ratio of the earthquake acceleration to gravity
ΔX_i	= coefficient of variation of $N X_i$ representing a measure of the errors in predicting X_i
Δ_R, Δ_S	= coefficients of variation, representing a measure of the errors in predicting R and S , respectively

- δX_i = coefficient of variation of X_i , representing a measure of the basis variability in X_i
- δ_R, δ_S = coefficients of variation, representing a measure of the basic variabilities in R and S, respectively
- σ = unit compressive strength of the foundation material
- σ_R, σ_S = standard deviation of R and S, respectively
- θ', θ'' = angle of inclination with the vertical of the upstream and downstream faces of the dam, respectively
- ϕ = angle of internal friction for the foundation material
- $\Omega_h, \Omega_q, \Omega_p, \Omega_\sigma$ = coefficients of variation, representing the measures of the total uncertainties in the theoretical functions, respectively
- ΩX_i = coefficient of variation, representing measure of the total uncertainties in X_i
- Ω_R, Ω_S = coefficients of variation, representing measures of the total uncertainties in R and S, respectively
- ρ = correlation coefficient

Prendergast, James D

Probabilistic concept for gravity dam analysis. -- Champaign, IL : Construction Engineering Research Laboratory ; Springfield, VA : available from NTIS, 1979.
68 p. 27 cm. (Special report ; M-265)

1. Dam safety. 2. Gravity dams. I. Title. II. Series: U.S. Army Construction Engineering Research Laboratory. Special report ; M-265.

CERL DISTRIBUTION

Chief of Engineers
ATTN: DAEN-MPR
ATTN: DAEN-RDL
ATTN: DAEN-ASI-L (2)
Dept of the Army
WASH DC 20314

Defense Documentation Center
ATTN: DDA (12)
Cameron Station
Alexandria, VA 22314

DEPARTMENT OF THE ARMY
CONSTRUCTION ENGINEERING RESEARCH LABORATORY

CORPS OF ENGINEERS
P.O. BOX 4005
CHAMPAIGN, ILLINOIS 61820

OFFICIAL BUSINESS
PENALTY FOR PRIVATE USE \$300



POSTAGE AND FEES PAID
DEPARTMENT OF THE ARMY
DOD - 314



THIRD CLASS