

AD-A073 973

ARMY MISSILE RESEARCH AND DEVELOPMENT COMMAND REDSTO--ETC F/6 9/2
HIGH SPEED FUNCTION GENERATION FOR RESEARCH AND PROJECT SUPPORT--ETC(U)
JUN 79 C L LEWIS, G M GRINER, L H HAZEL
DRDNI-T-79-66

UNCLASSIFIED

NL

DF
AD
A073973

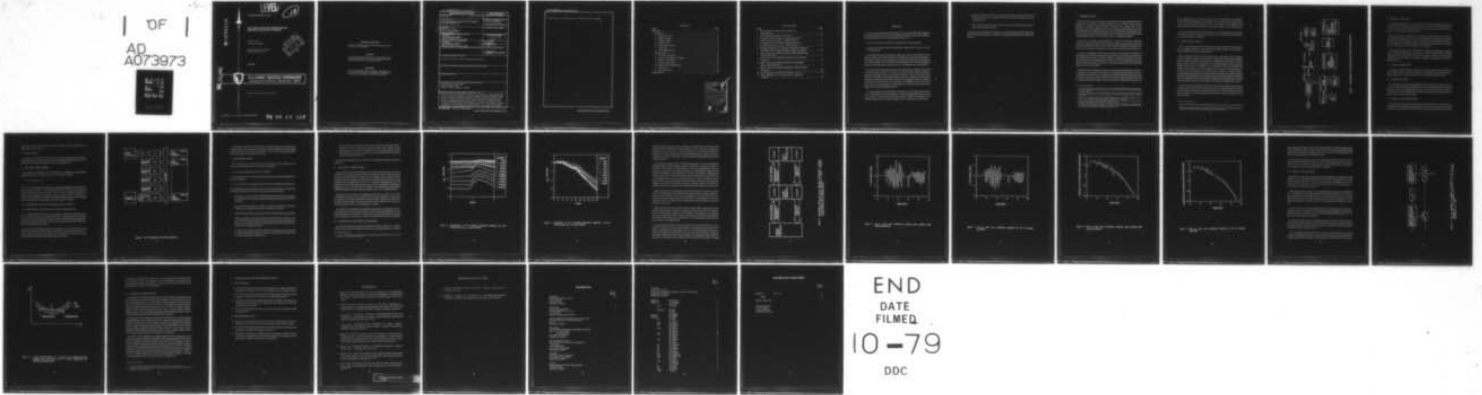

END
DATE
FILMED
10-79
DDC

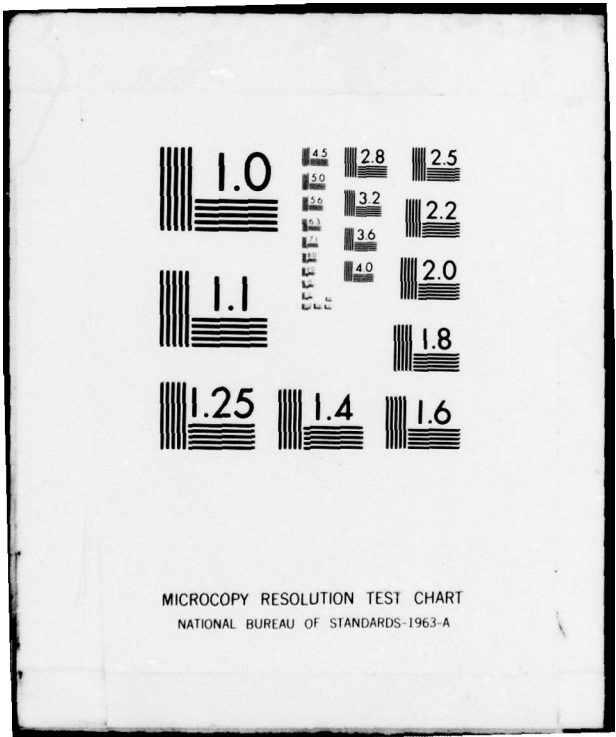

MICROCOPY RESOLUTION TEST CHART
NATIONAL BUREAU OF STANDARDS-1963-A

LEVEL

p.s. 12

TECHNICAL REPORT T -79-66

AD A 073973

**HIGH SPEED FUNCTION GENERATION FOR
RESEARCH AND PROJECT SUPPORT**

Charles L. Lewis
Technology Laboratory

Gary M. Griner, Larry H. Hazel
Science Applications, Inc.

DDIC
RECEIVED
SEP 19 1979

June 1979

DDC FILE COPY



U.S. ARMY MISSILE COMMAND

Redstone Arsenal, Alabama 35809

Approved for public release; distribution unlimited.

8

DISPOSITION INSTRUCTIONS

DESTROY THIS REPORT WHEN IT IS NO LONGER NEEDED. DO NOT RETURN IT TO THE ORIGINATOR.

DISCLAIMER

THE FINDINGS IN THIS REPORT ARE NOT TO BE CONSTRUED AS AN OFFICIAL DEPARTMENT OF THE ARMY POSITION UNLESS SO DESIGNATED BY OTHER AUTHORIZED DOCUMENTS.

TRADE NAMES

USE OF TRADE NAMES OR MANUFACTURERS IN THIS REPORT DOES NOT CONSTITUTE AN OFFICIAL ENDORSEMENT OR APPROVAL OF THE USE OF SUCH COMMERCIAL HARDWARE OR SOFTWARE.

14 DRDMI-T-79-66

Unclassified

SECURITY CLASSIFICATION OF THIS PAGE (When Data Entered)

REPORT DOCUMENTATION PAGE		READ INSTRUCTIONS BEFORE COMPLETING FORM
1. REPORT NUMBER T-79-66	2. GOVT ACCESSION NO.	3. RECIPIENT'S CATALOG NUMBER (9)
4. TITLE (and Subtitle) HIGH SPEED FUNCTION GENERATION FOR RESEARCH AND PROJECT SUPPORT		5. TYPE OF REPORT & PERIOD COVERED Technical Report
7. AUTHOR(s) Charles L. Lewis, Gary M. Griner, Larry H. Hazel		6. PERFORMING ORG. REPORT NUMBER
9. PERFORMING ORGANIZATION NAME AND ADDRESS Commander US Army Missile Command ATTN: DRSMI-TGN (R&D) Redstone Arsenal, Alabama 35809		8. CONTRACT OR GRANT NUMBER(s)
11. CONTROLLING OFFICE NAME AND ADDRESS Commander US Army Missile Command ATTN: DRSMI-TI (R&D) Redstone Arsenal, Alabama 35809		10. PROGRAM ELEMENT, PROJECT, TASK AREA & WORK UNIT NUMBERS (12) 34p
14. MONITORING AGENCY NAME & ADDRESS (if different from Controlling Office)		12. REPORT DATE June 1979
		13. NUMBER OF PAGES 31
		15. SECURITY CLASS. (of this report) Unclassified
16. DISTRIBUTION STATEMENT (of this Report) Approved for public release; distribution unlimited.		15a. DECLASSIFICATION/DOWNGRADING SCHEDULE
17. DISTRIBUTION STATEMENT (of the abstract entered in Block 20, if different from Report)		
18. SUPPLEMENTARY NOTES		
19. KEY WORDS (Continue on reverse side if necessary and identify by block number) Hardware-in-the-Loop (HWIL) Applied Dynamics (AD) Homing and Laser Simulation (HALS)		
20. ABSTRACT (Continue on reverse side if necessary and identify by block number) Since 1972, the US Army Missile Research and Development Command (MIRADCOM) has maintained and operated a real-time hardware-in-the-loop (HWIL) homing missile simulation at Redstone Arsenal, Alabama. Because of the need for a detailed, accurate simulation and to support the US Army Modular Missile research program and other advanced missile research, a decision was made to upgrade the HWIL simulation by adding a special purpose digital processor. The processor selected was the Applied Dynamics, Inc., AD 10. This report describes the work performed to program the AD 10 and modify the existing		

DD FORM 1473 1 JAN 73 EDITION OF 1 NOV 65 IS OBSOLETE

SECURITY CLASSIFICATION OF THIS PAGE (When Data Entered)

393 427

JOB

→ next page

Unclassified

SECURITY CLASSIFICATION OF THIS PAGE(When Data Entered)

20. simulation for the Homing and Laser Simulation Facility (HALS).

SECURITY CLASSIFICATION OF THIS PAGE(When Data Entered)

CONTENTS

Section	Page
PREFACE	3
1. Introduction	5
A. Simulation Facility	6
B. Digital Computer	8
C. Analog Computer	8
D. Interface Units	8
E. Laser Target Simulator	8
F. Flight Table	9
G. AD 10 Multiprocessor	9
2. Implementation	11
A. Aero Data Verification	12
B. Interface to the Sigma 5 Computer	12
C. Other AD-10 Software	21
D. Further Considerations	24
3. Conclusions and Recommendations	25
A. Conclusions	25
B. Recommendations	25
REFERENCES	27

Accession For	
NTIS GR&I	<input checked="" type="checkbox"/>
DDC TAB	<input type="checkbox"/>
Unannounced	<input type="checkbox"/>
Justification	<input type="checkbox"/>
By _____	
Distribution/	
Availability Codes	
Dist	Avall and/or special
A	

ILLUSTRATIONS

Figure	Page
1. Block Diagram of Homing and Laser Simulation (HALS) Facility	7
2. AD 10 Multiprocessor System Architecture	10
3. Comparison of AD 10 Function Generation (Symbols) and AeroData (Curves). C_{m_α} vs. Mach Number.....	13
4. Comparison of AD 10 Function Generation (Symbols) and AeroData (Curves). C_{m_α} vs. Angle of Attack	14
5. Experiment Using AD 10 to Generate Aerodynamic Functions for All-Digital 6 DOF Program Executing on Sigma 5 Computer.....	16
6. Yaw vs. Time. Aero Coefficients Obtained Using Standard Table Lookup Subroutines.....	17
7. Yaw vs. Time. Aero Coefficients Obtained by AD 10 Function Generation.....	18
8. Pitch vs. Time. Aero Coefficients Obtained Using Standard Table Lookup Subroutines.....	19
9. Pitch vs. Time. Aero Coefficients Obtained by AD 10 Function Generation.....	20
10. AD 10 Algorithm to Evaluate The Fraction x/y For $x < y$	22
11. Linear Approximation to a Function $f(z)$ Having Positive Curvature	23

PREFACE

The US Army Missile Research and Development Command (MIRADCOM) is engaged in a research program to develop an advanced guidance and control system for future (1990s) US Army Modular Missiles. The formal program objectives are to

- Extend G&C system technology that "leapfrogs" the current design base.
- Provide and validate research enabling digital optimal G&C of future US Army Modular Missile.

To accomplish these goals, the principal investigators have defined several technical areas in which government and contract personnel are contributing to the overall program objectives. These technical areas are target/missile scenarios, missile plant characteristics, aerodynamics, error sources, guidance laws, disturbance accommodating control, sensor characteristics, computer-aided design tools, microprocessor SOA, and digital design tool development.

One of the computer-aided design tools that must be provided to accomplish the second of the above program objectives is a flexible, fast homing missile simulation capable of accommodating highly maneuvering advanced modular missiles. The existing HWIL simulation is adequate for serving as this design tool only if it is upgraded so as to permit the high-order aerodynamic models needed for advanced interceptors. The high-order model is a consequence of the expected use of "unconventional" aerodynamic effects such as elliptical body cross-section, large deployable control surfaces, jet interaction control, bank-to-turn guidance, and certainly high-angles of attack.

To accomplish the necessary modification to the HWIL, a major redesign of the simulation so as to accommodate an AD-10 multiprocessor, a special purpose digital processor capable of extremely fast function generation (table lookup), coordinate transformations, and algebraic computations was required. Specifically, the following tasks were performed:

- Program the AD-10 multiprocessor in assembly language to interface with advanced simulation techniques for optimal theoretical G&C systems for future US Army Modular Missiles.
- Modify the advanced simulation to interface through the CI-5000 Analog Computer to these assembly language programs.

Inasmuch as these tasks permit the simulation to evaluate advanced modular missiles, this effort will define characteristics of available (and potential) guidance sensors, plants, and effectors.

1. INTRODUCTION.

Since 1972, the US Army Research and Development Command (MIRADCOM) has maintained and operated a real-time hardware-in-the-loop (HWIL) homing missile simulation at Redstone Arsenal, Alabama.¹ Operated by the Guidance and Control Directorate, this hybrid simulation has been used to perform guidance and control system design verification², to verify flight hardware,^{3,5} and to evaluate digital autopilot designs.⁴ The class of weapon which has been accommodated by this simulation is a semiactive laser homing terminally guided vehicle such as the Hellfire missile or Copperhead projectile.

The need for a detailed, accurate simulation is obvious. The need for a high-speed simulation is twofold. If missile hardware components (seekers, gyros, autopilots) are in the loop, then the simulation must run in real time. If missile components are simulated, then faster than real time runs are desirable so that Monte Carlo studies become economical.

It has been recognized for some time that evaluation of aerodynamic coefficients (by interpolation in stored tables) dominates the cpu run time. Thus, in order to achieve speed, it has sometimes been necessary to sacrifice accuracy by neglecting second-order aero terms, ignoring the effect of certain independent variables (e.g., roll) on aero coefficients, by storing sparse data points (this also saves memory), and finally by performing table interpolation partially on the analog computer.

While the HWIL has satisfactorily simulated several terminal homing missiles in the past, it would appear to be inadequate for the study of very high performance interceptors such as is envisioned for the 1990s. In order to support the US Army Modular Missile research program and other advanced missile research, the decision was made to upgrade the HWIL simulation by adding a special purpose digital processor. It has been shown that peripheral successors can

-
1. H.L. Pastrick, W.H. Holmes, C.M. Will, L.S. Isom, and A.C. Jolly, "Real-time Hybrid Hardware-in-the-Loop Simulation of a Terminal Homing Missile." *Proceedings of the 1973 Summer Computer Simulation Conference*, Montreal, Canada, July 1973, pp. 264-268.
 2. H.L. Pastrick, C.M. Will, L.S. Isom, L.H. Hazel, and R.J. Vinson, "Hardware-in-the-Loop Simulations: A Guidance System Optimization Tool," *Paper No. 74-929, AIAA Mechanics and Control of Flight Conference*, Anaheim, California, August 1974.
 3. _____, "The Efficacy of Hardware in Validating Hardware-in-the-Loop Simulations," *Proceedings of the 1975 Summer Computer Simulation Conference*, San Francisco, California, July 1975, pp. 561-571.
 4. _____, "Hardware-in-the-Loop Simulation of a Digital Autopilot," *Proceedings of the 1978 Summer Computer Simulation Conference*, Newport Beach, California, July 1978, pp. 231-235.
 5. H.L. Pastrick, C.M. Will, L.S. Isom, A.C. Jolly, L.H. Hazel, and R.J. Vinson, "Recent Experience in Simulating Missile Flight Hardware in Terminal Homing Applications," *Proceedings of the Optics in Missile Workshop*, Society of Photo-Optical Instrumentation Engineers, Los Angeles, California, January 1970.

have a significant effect on the execution speed of missile simulations.^{6,7} The processor selected was the Applied Dynamics, Incorporated, AD 10. To achieve the full benefit of the AD 10, the basic simulation structure had to be modified as well, because several computational procedures formerly done on the analog computer were no longer needed.

The improved hybrid simulation will be referred to as the Homing and Laser Simulation (HALS) facility. This report describes the work performed to program the AD 10 and modify the existing simulation for the HALS.

A. SIMULATION FACILITY.

Figure 1 is a block diagram of the HALS facility showing basic hardware and information flow. The diagram illustrates a setup where missile seeker, autopilot, and unloaded fin actuator hardware are all in the simulation loop.

When in operation an infrared neodymium laser source, in conjunction with a servoed laser spot size controller, projects the laser spot onto a rear projection screen via a 2-axis gimballed mirror. The missile laser seeker is mounted on a 3-axis flight table which simulates the vehicle angular motion. The dual axis gimballed mirror provides apparent vehicle translation. Dynamic range closure is provided by the servo-driven, spot size controller that simultaneously controls the laser power (range) and spot size growth. Steering signals from the laser seeker are fed back thru an autopilot and the actuator to a hybrid computer containing mathematical models of vehicle aerodynamics, subsystem characteristics, guidance logic, and environmental effects. The computer controls the intensity and position of the laser spot target depending on certain selected mission parameters. Performance data is obtained from the computer in the form of miss distance, and subsystem parameter line histories.

Any and all of the missile hardware can be removed from the loop and simulated by digital or analog models. If the seeker unit is simulated, the laser is not needed and the target can be modeled mathematically. In this mode of operation HALS is, in effect, a 6-degree-of-freedom hybrid simulation. The following paragraphs briefly describe the major components in the simulation facility.

-
6. W.J. Karplus, "Peripheral Processors for High-Speed Simulation," *Simulation*, Volume 29, No. 5, November 1977, pp. 143-153.
 7. R.H. Bensinger, "Real Time Simulation of Six-Degree-of-Freedom Multivariable Forces and Moments in Less than One Millisecond," Missile Systems Division, Rockwell International, Columbus, Ohio, 1978.

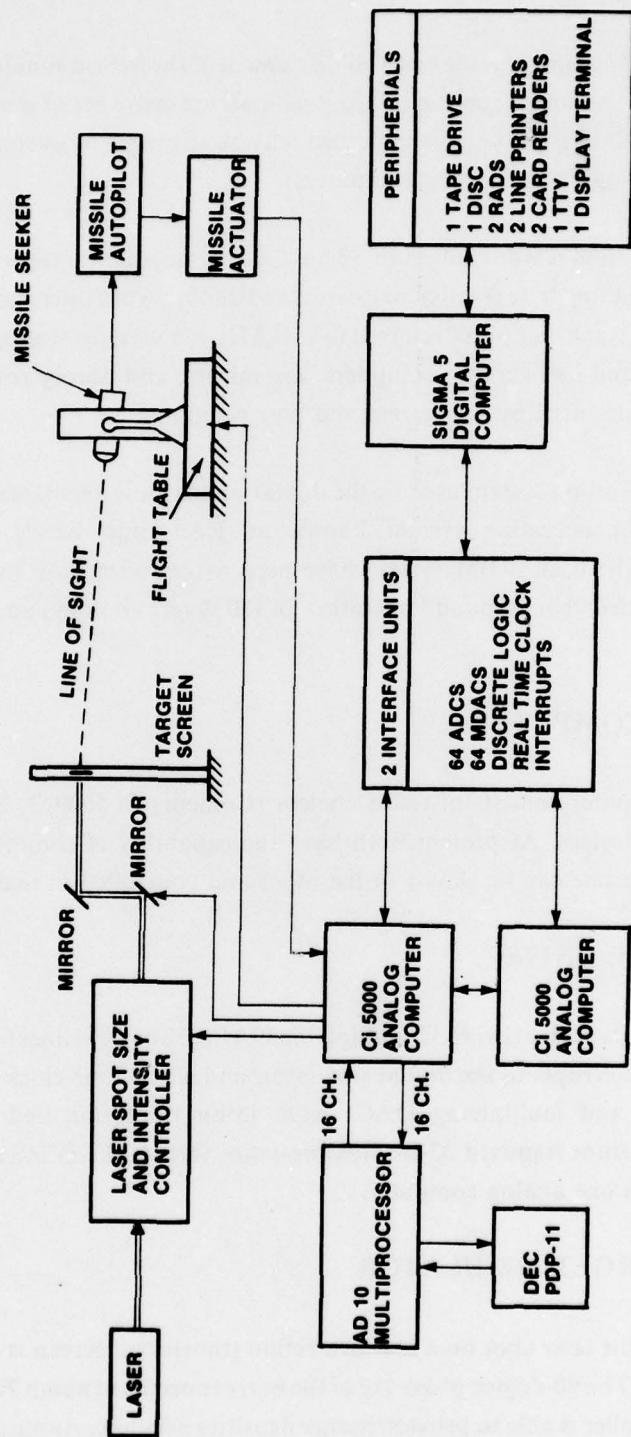

Figure 1. Block diagram of homing and laser simulation (HALS) Facility

B. DIGITAL COMPUTER

A Sigma 5 digital computer is the controlling element of the hybrid simulation. The Sigma 5 interfaces with the two analog computers and with an extensive set of peripheral devices. A total of 16 priority interrupts are available and may be triggered by events within the digital program or occurring on the analog computers.

The Sigma 5 employs a word length of 32 bits but the instruction repertoire also includes instructions for handling byte (8-bits), half-word and double-word operations and arithmetic. Two two-head-per-track disk units, referred to as RADs, are used for storing system programs (i.e., the monitor and its overlays, compilers, assemblers, and library routines), permanent files, and scratch files used by the system and user programs.

The software operating system used by the digital simulator is an adaptation of a standard Xerox (Honeywell) operating system known as Real-Time Batch Monitor (RBM). Enhancements to the basic RBM system have been made to improve its batch processing capability (also called "background" operation in RBM terminology) and its suitability for hybrid simulation.

C. ANALOG COMPUTER.

The analog computer consists of two Denelcor (Comcor) Ci-5000/3. Both machines are 100-V solid state devices. At present both have the capability of communicating with the digital simulator or one can be slaved to the other and controlled in that manner.

D. INTERFACE UNITS.

Two interface units each provide 32 multiplying DACs, 32 control lines (discretes), 32 sense lines, 16 external interrupts to the digital simulator, and a real-time clock with microsecond resolution. ADCs and multiplying DACs have 15-bit resolution and the capability of converting to and from standard 32-bit floating-point format. Each interface connects the digital computer to one analog computer.

E. LASER TARGET SIMULATOR.

The position of the laser spot on a rear projection translucent screen is controlled by two gimbaled mirrors. The 90-degree phase lag of the mirrors occurs at about 70 Hz. The spot size and intensity controller is able to provide energy densities which span approximately 53 dB as

measured at the seeker location. This represents an equivalent seeker-to-target distance of approximately 25 m to 11600 m.

F. FLIGHT TABLE.

The three-axis Carco flight table is a precision electro-hydraulic positioner which simulates angular flight motion. It has hydraulic positioner which simulates angular flight motion. It has hydraulic drives, magnesium gimbals, and precision analog pickoffs.

G. AD-10 MULTIPROCESSOR.

The component being added to the HALS facility is a fixed-point, 16-bit, high-speed peripheral multiprocessor capable of executing the arithmetic instruction

$$R = \pm(A \pm B) \times C \pm D$$

in 175 ns. It is thus capable of performing very rapid linear interpolation for the purpose of function generation. *Figure 2* is a block diagram of the AD 10 system architecture. The multibus contains 16 data lines, 18 address lines, and several control lines and supports 20 transfers per microsecond. All transfer as well as memory processor functions are synchronously controlled by a 40-MHz clock. Each functional unit has a separate program memory which controls its actions during each memory cycle, as follows:

- the DEP (Decision Processor) for determining function breakpoints,
- the MAP (Memory Address Processor) for address determination, and
- the ARP (Arithmetic Processor) for executing the interpolation instruction above. Prior to a computer run, the host computer (DEC PDP-11) through the HIC (Host Interface Controller) loads each of the program memories, tabular data, breakpoint data, and slope and gain factors into multiport data memory. Data memory is organized into "pages" of 4K words, each page independently addressable.

Once the AD 10 is loaded and started by the host PDP-11, it cycles under control of the COP (Control Processor) without further communication with the host machine for days or weeks, if desired. It passes input/output data via 32 channels connected to the analog computer through the IOCC (Input/Output Channel Controller).

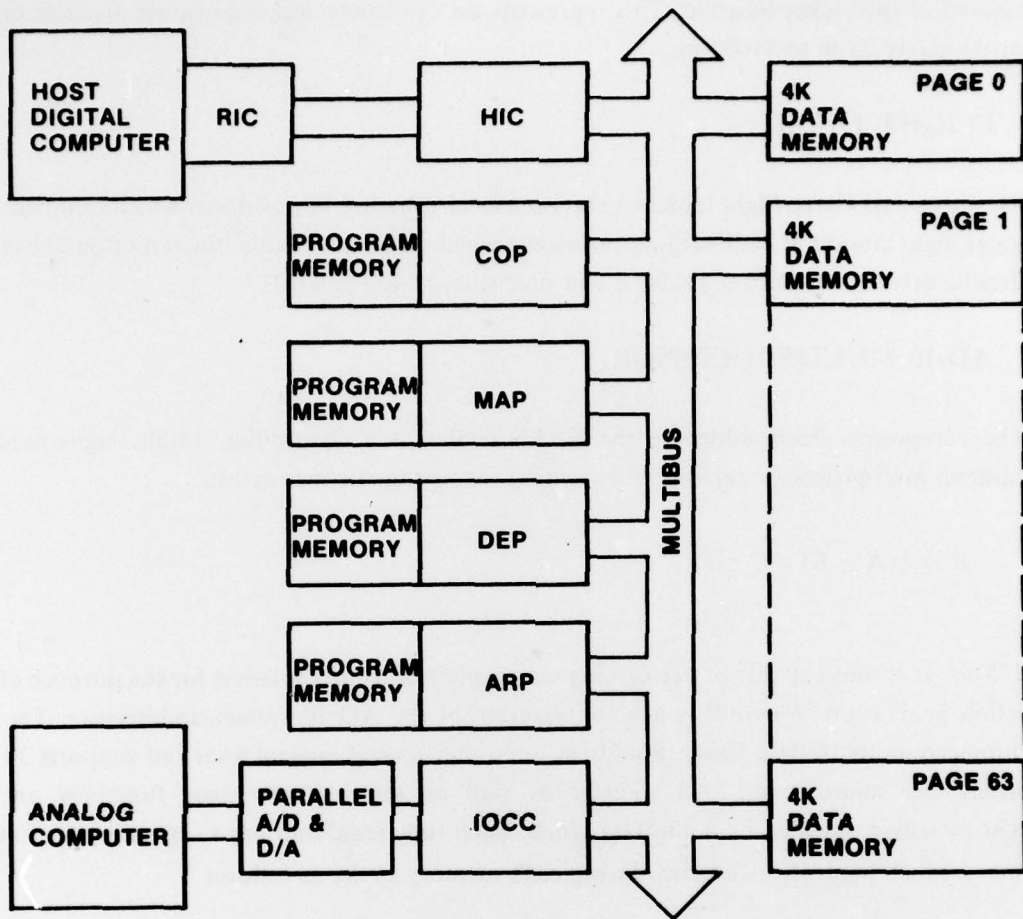

Figure 2. AD 10 multiprocessor system architecture

A useful feature of the AD 10 is the software provided with the system. The AD 10 Cross Assembler runs on the host computer and converts assembly language or macrofile programs into object modules. The AD 10 Executive (ADX) is used to load, start, stop, and otherwise control and monitor the operation of the AD 10.

2. IMPLEMENTATION

The incorporation of the AD 10 into the HALS facility has been guided by a very conservative philosophy based on the following considerations:

- The AD 10 programming software was unfamiliar,
- HALS had to continue to support normal G&C laboratory activities during checkout of the AD 10 installation,
- the AD 10 clearly was capable of doing more than just perform fast table lookups.

The following step-by-step implementation plan was subsequently adopted to accomplish the installation and checkout of the AD 10 as required by the Scope of Work.

- Develop for the host computer a FORTRAN program which accepts aerodynamic data and generates the required interpolation tables and scaling factors for the AD 10 data base.
- Select a test missile and plot the original aero data to verify that errors are absent. Subject the aero coefficient data to step 1 and install on the AD 10.
- Modify the hybrid simulation to interface to the AD 10 through the analog computer.
- Develop a program for the hybrid computer which requests aero coefficient values from the AD 10 using this interface. Plot the AD 10 function values on the original aero data curves to verify that the AD 10 is returning the proper values for all functions over all ranges of the independent variables.
- For the test missile make a benchmark 6-degree-of-freedom trajectory run. Repeat the run replacing the standard interpolation subroutines with calls to the AD 10 as in step 3. Verify by comparing to benchmark run.

- Write code for the AD 10 to perform division and square root operations. Write a program for AD 10 to interpolate in moment of inertia table, compute dynamic pressure and return the rotational acceleration terms. Check against baseline run. Add interpolation for thrust, mass, center of gravity and compute translational acceleration terms. Check against baseline run.

The following paragraphs discuss the results from this installation and program verification procedure.

A. AERO DATA VERIFICATION.

An aero coefficient data base of 6,000 words for the Hellfire missile was selected to test the FORTRAN input program and the AD 10 function generation output. The data contained 9 functions of a single variable, 21 functions of two variables, and five functions of three variables. While it was tempting to avoid the step of checking the basic aero data for errors and immediately start programming the AD 10, the conservative approach paid off. Visual inspection of the aero data plots produced about a dozen inconsistencies (including two keypunch errors). The corrected data was subjected to the interpolation table generation FORTRAN program and these tables were installed on the AD 10, completing Step 2.

Following the normal amount of debugging and trial and error, Steps 3 and 4 were accomplished. *Figures 3 and 4* are typical of results which were obtained. $C_{M\alpha}$, a function of two variables, is shown plotted against Mach number in *Figure 3* and against α in *Figure 4*. In both figures the data symbols are values returned by the AD 10 while the curves are plotted from the original aero data. The close agreement is apparent.

The complete set of aerodynamic coefficient plots are presented in a separate report.⁸ Since standard macrocode provided with the AD 10 was used to perform the interpolations, it was not surprising that correct results were obtained once the interpolation tables were properly input. Unexpectedly, during this effort a defective memory element was found and replaced.

B. INTERFACE TO THE SIGMA 5 COMPUTER.

For purposes of speed and economy, the mathematical models in HWIL were originally carefully allocated to either the digital (low frequency) or analog (high frequency) portions of

8. G. M. Griner, "Aerodynamic Coefficient Data Plots for Hellfire Modular Missile System Flight Test Configuration," Science Applications, Inc., SAI-80-524-HU, 5 March 1979.

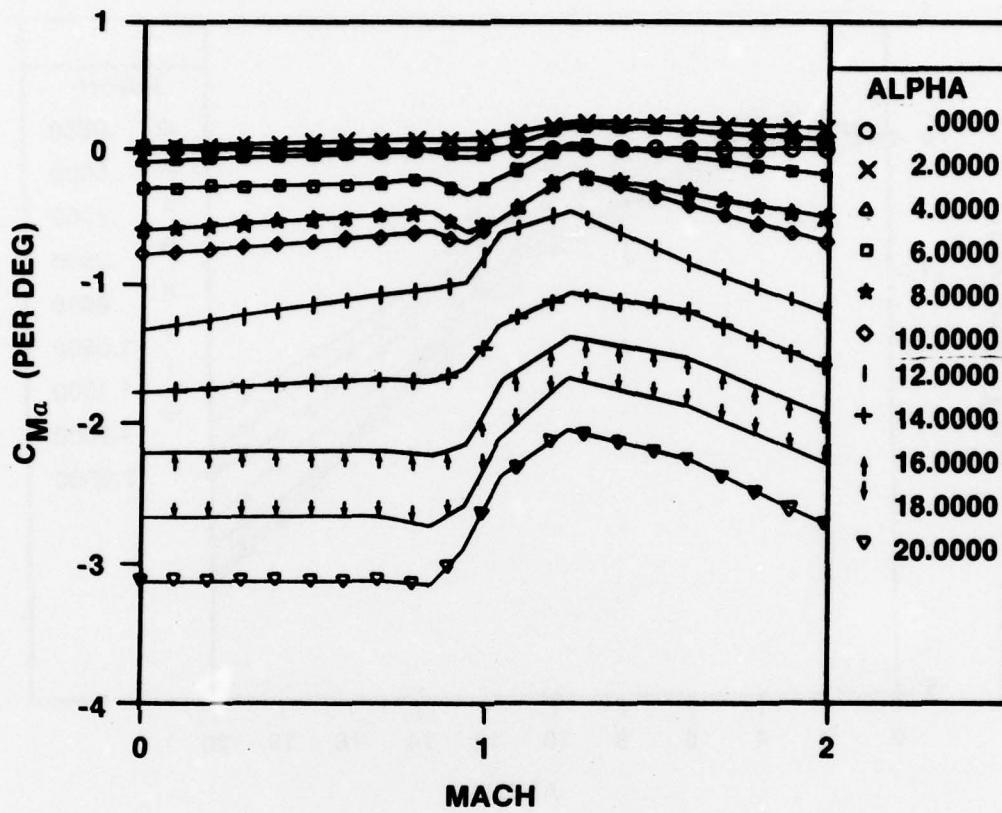

Figure 3. Comparison of AD 10 function generation (symbols) and aero-data (curves). $C_{M_{\alpha}}$ vs. mach number.

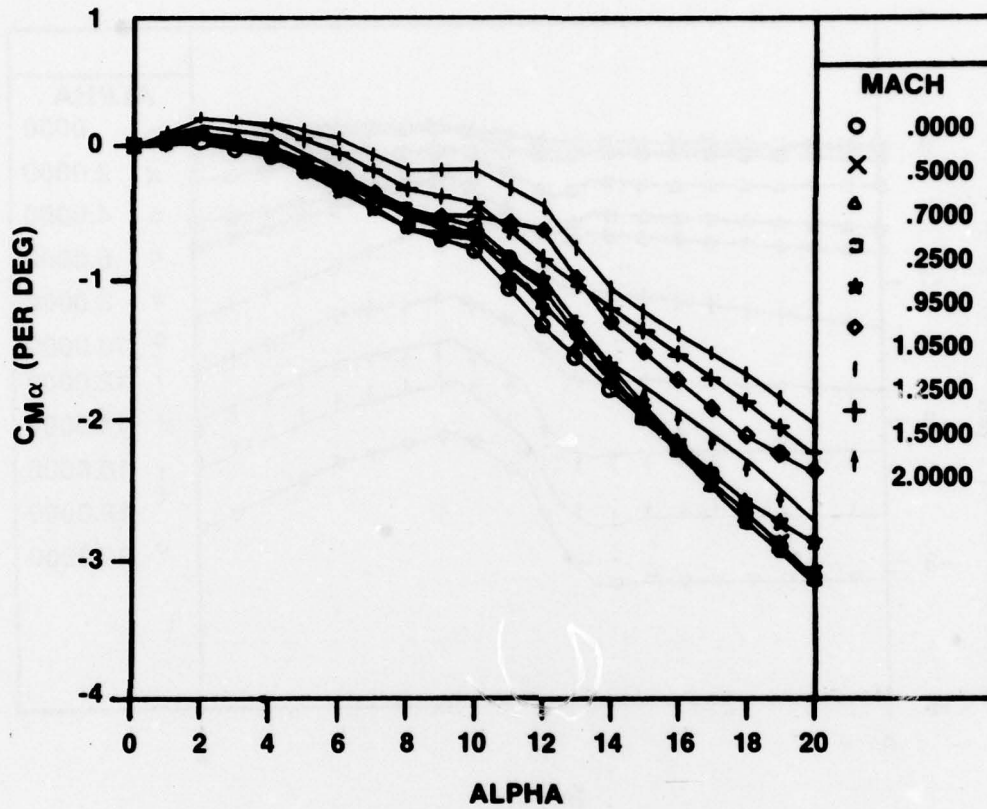

Figure 4. Comparison of AD 10 function generation (symbols) and aero-data (curves). $C_{m\alpha}$ vs. angle of attack.

the hybrid computer. Because the aero coefficients are tabulated functions, the table lookup had been at first attempted on the digital computer. In order to be able to compute aero coefficients every 5 ms however, it was found necessary to perform table interpolation partially on the analog computer after having obtained digital slope and intercept values. For this reason it is now not a simple task to replace the table lookup procedure with an AD 10 function evaluation.

It was therefore decided to test the AD 10 function generation in a simulation using another all-digital 6-degree-of-freedom Hellfire simulation, DIMODS. A unique experiment was carried out with the digital AD 10 providing aero data to the all-digital missile simulation executing on the Sigma 5, with data passing back and forth through the analog computer interface as illustrated in *Figure 5*. Because only 16 DAC/ACD ports are available thru the analog computer, the 35 functions were actually obtained in blocks using 3 subroutine calls every integration step. An AD 10 interface program was written to recognize the block number and to return the appropriate coefficient values as a function of the independent variables being supplied. This technique resulted in the digital computer obtaining all 35 coefficient values in 11 mS, whereas the standard interpolation subroutines require 133 mS.

Figures 6-9 illustrate the close agreement between the benchmark run and the run with AD 10. Error is introduced by use of the AD 10 in this test because analog-to-digital and digital-to-analog conversion hardware is only 12 bits as compared to the Sigma 5 32-bit word. The presence of the analog computer also prevents absolute run-to-run repeatability. These errors are small, however, as is apparent from the figures and the fact that terminal miss distance differed by only 0.2 inch.

Applied Dynamics offers an External Computer Interface (EXCI) module which would permit the digital Sigma 5 computer to communicate directly with the AD 10 through the IOCC Unit, obviating the necessity of the intermediate analog computer. The significant increase in speed demonstrated in the above experimental run could be increased further by the addition of this interface device. In addition, run-to-run repeatability would be achieved when running in the all-digital mode.

During this phase of the effort it became clear that the present 32K of AD 10 memory is not sufficient for the high-order aero models expected in the digital modular missile research program. The Hellfire aero model which served to test the assembly language programs was easily accommodated but estimates of the storage requirements to implement a Copperhead aero model showed that at least 132K was needed. The Copperhead model requires the evaluation of 15 functions of one variable and 23 functions of four variables. The large

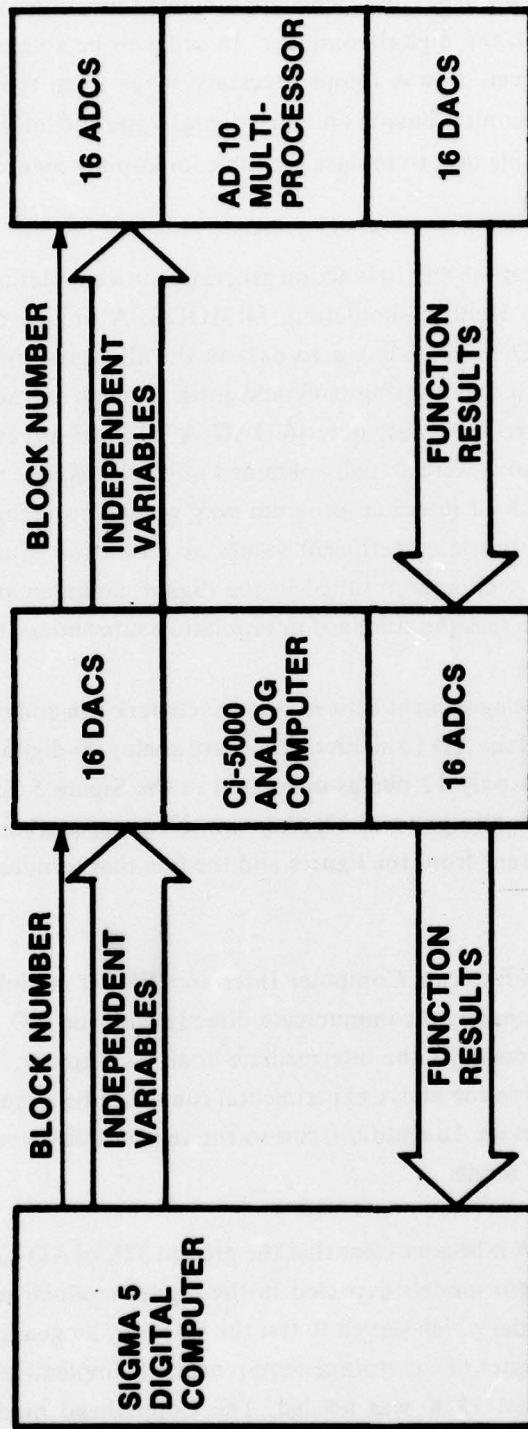

Figure 5. Experiment using AD 10 to generate aerodynamic functions for all-digital 6 DOF Program Executing on Sigma 5 computer. Analog computer acts as interface device.

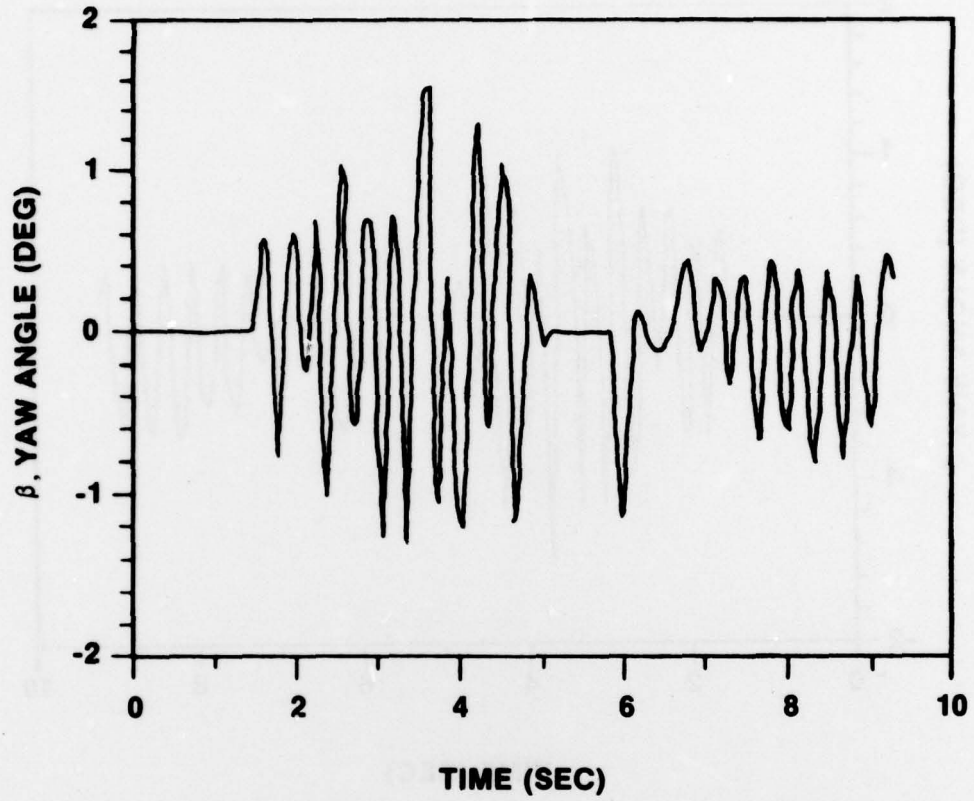

Figure 6. Yaw vs. time. Aero coefficients obtained using standard table lookup subroutines.

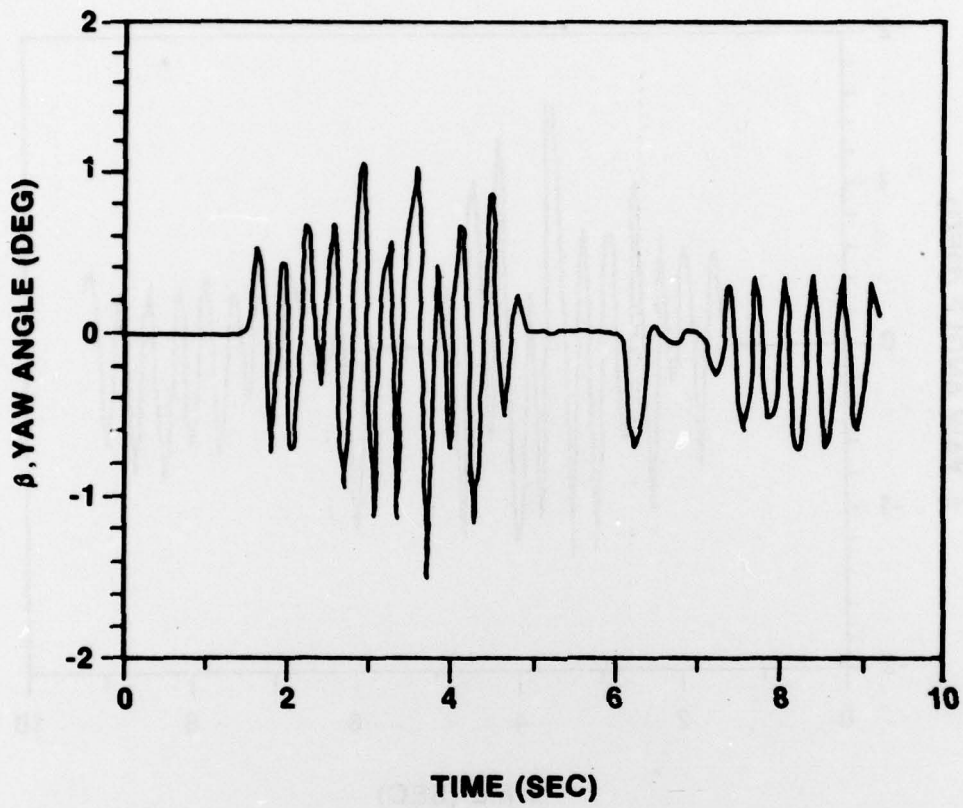

Figure 7. Yaw vs. time. Aero coefficients obtained by AD 10 function generation.

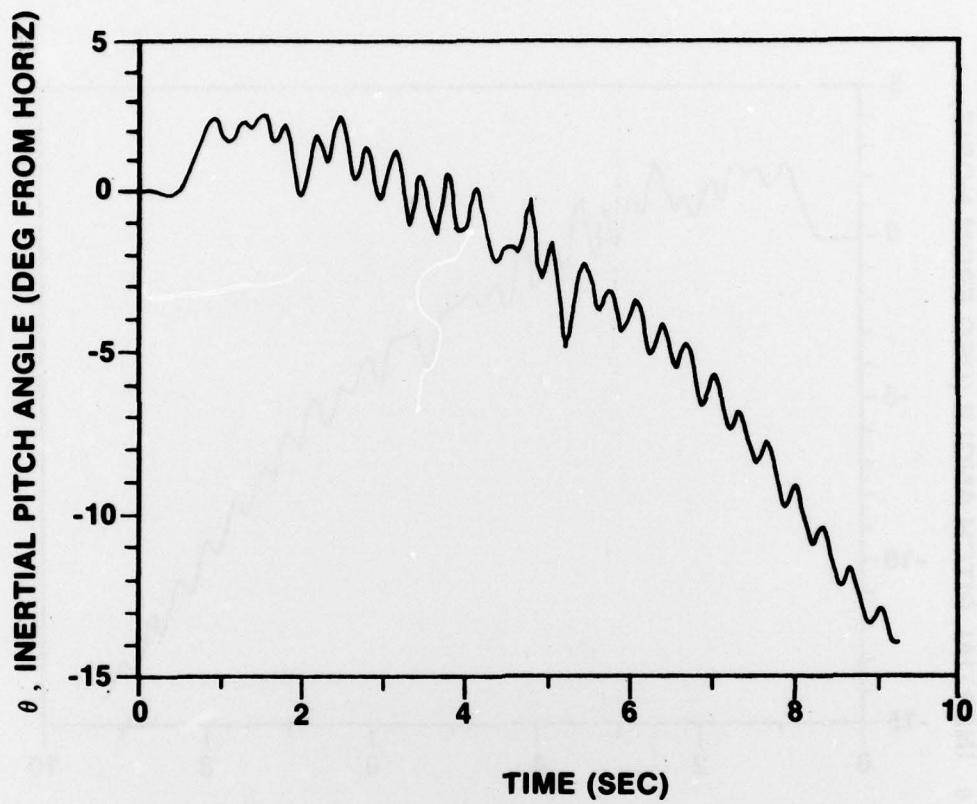

Figure 8. Pitch vs. time. Aero coefficients obtained using standard table lookup subroutines.

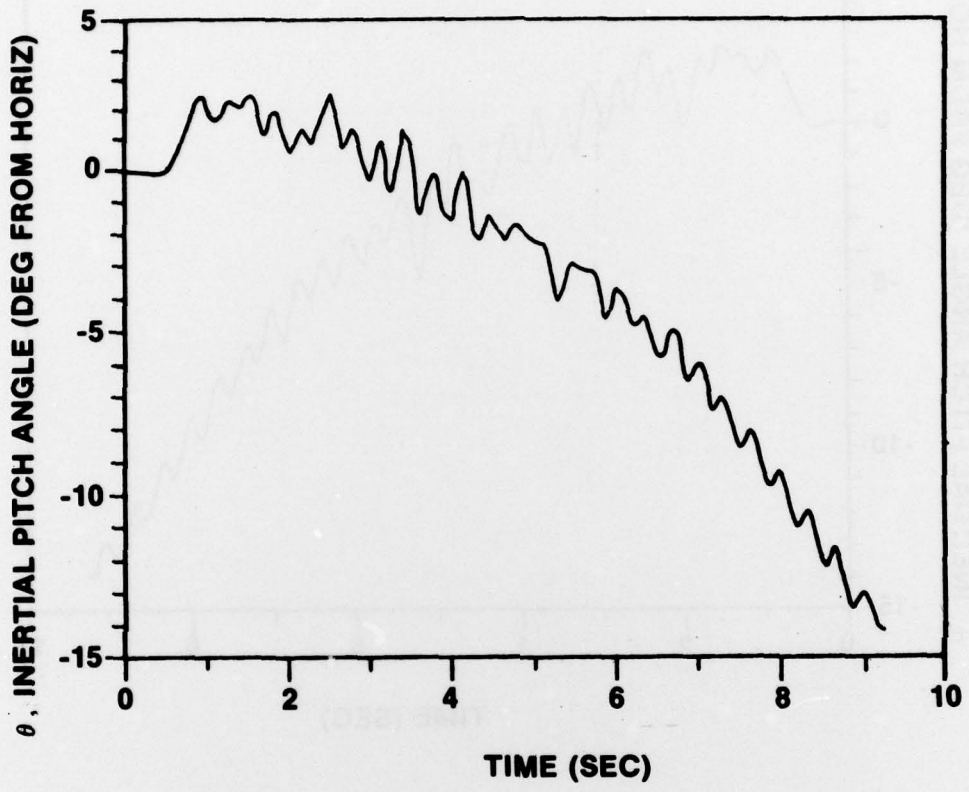

Figure 9. Pitch vs. time. Aero coefficients obtained by AD 10 function generation.

memory requirement comes from the fact that these 38 functions are tabulated at many values of the independent variables and also because during the flight wings are deployed which change all the aerodynamic coefficient values. Thus, two sets of aero tables must reside in memory to accommodate the configuration change.

Deployment of high-lift surfaces is one of the concepts which has been mentioned to achieve high-g maneuvering capability at end-game for the Army Modular Missile. This, as well as other unconventional methods of achieving missile control, imply that more AD 10 memory will be required to permit model implementation by HALS.

C. OTHER AD 10 SOFTWARE.

Macrofiles have been written to perform division and square root evaluation for scaled (between -1 and +1) input. Both operations utilize the fast DEP breakpoint determination and ARP interpolation algorithm. The division is performed by interpolating on the stored function $f(z) = (0.5/z) - e$, where e is the desired interpolation error. The evaluation of x/y ($x < y$) proceeds as illustrated in *Figure 10*.

Using a binary search, an integer n is found such that the product $z = y(2)^n$ is between 0.5 and 1. A table lookup for $f(z)$ is then performed and the result is multiplied by $x2^{n+1}$ to obtain the desired dividend. As illustrated in *Figure 11*, fewer breakpoints are required for the same interpolation accuracy if the tabulated function is $(0.5/z) - e$ rather than simply $0.5/z$. For a function having negative curvature, such as \sqrt{z} , the tabulated function should be $f(z) = \sqrt{z} + e$.

An error less than 2^{-15} (the least significant bit of the AD 10 word) can be achieved if the function $(0.5/z) - 2^{-15}$ is tabulated at $1 + 2^7 = 129$ equally spaced breakpoints. The square root macrofile provided with the AD 10 software is presently being used although it is not very accurate for small values of the argument.

A macrofile has been written to compute three divisions. In order to achieve maximum speed, three copies of the function $f(z)$ are stored in data memory, each on a different memory page. By properly interleaving the code, three square root evaluations were also included with no increase in the $6.1 \mu s$ execution time.

An AD 10 application program has been written which not only generates the values of all aerodynamic coefficients but also forms and evaluates the expressions giving rotational and translational acceleration components. Twelve quantities can be input to the AD 10 from the

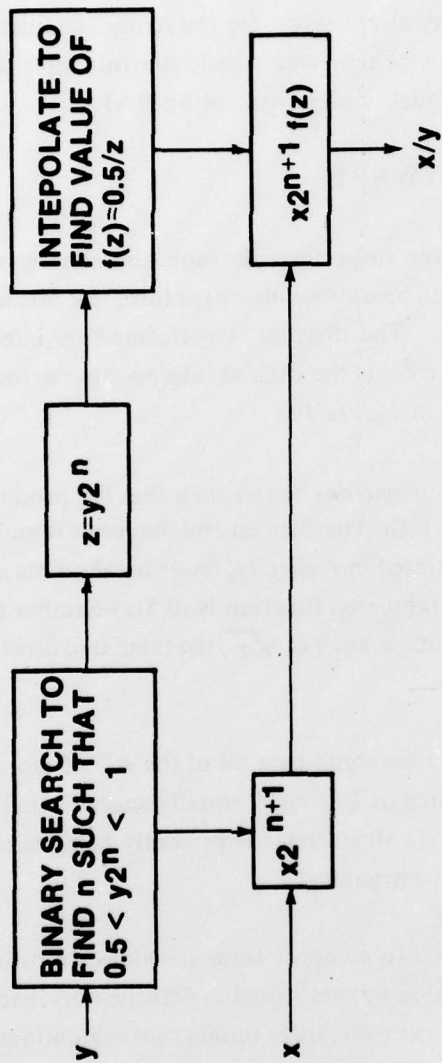

Figure 10. AD 10 algorithm to evaluate the fraction x/y for $x < y$. Accuracy of $\pm 2^{-15}$ achieved for $0.5 \leq z \leq 1.0$ if function tabulated at $\Delta z = 1/256$.

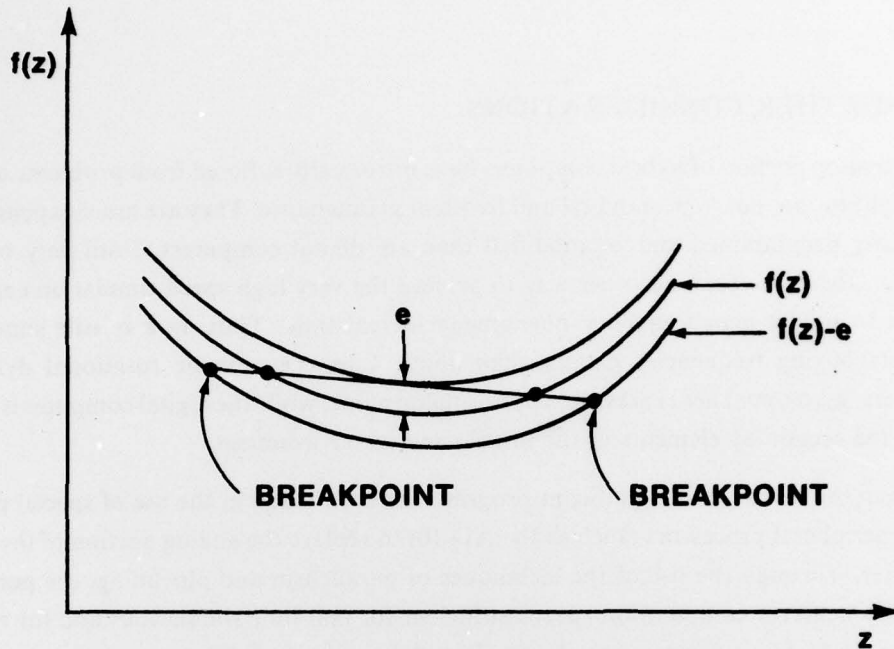

Figure 11. Linear approximation to a function $f(z)$ having positive curvature. For the same error, e , fewer breakpoints are needed by tabulating $f(z)-e$.

analog. These are altitude, Mach number, time, 4 vane angles, pitch and yaw angles of attack, and 3 rotational velocities. This program is necessarily dependent on the particular terms present in the aerodynamic model. Otherwise it could be used for various missiles by simply loading the function tables with the proper data.

D. FURTHER CONSIDERATIONS.

The analog portion of hybrid computers have historically suffered from problems of noise, drift, calibration, non-repeatability, and frequent maintenance. They are more expensive and less easily programmed and/or modified than are digital computers. Until very recently, however, there has been no other way to achieve the very high speed simulation capability needed to model high frequency phenomena in real time. Thus, in a missile simulation, elements having frequencies greater than about 1 hz (i.e., missile rotational dynamics, actuators, gyros, etc.) are represented by an analog model while the digital computer is used to model the remaining elements of the missile and its environment.

During the last 3 years, significant progress has been made in the use of special purpose digital peripheral processors (such as the AD 10) to replace the analog portion of the hybrid computer. Through the use of the techniques of parallelism and pipelining, the peripheral processor achieves computation speeds sufficient for real-time simulations and for efficient solution of highly maneuvering advanced modular missiles.⁶ If such a processor has the capability to integrate differential equations, then this "parallel/sequential" digital computer is a cost-effective replacement for the traditional hybrid computer.⁹

The AD 10 could be expanded into a digital replacement for the analog portion of the hybrid computer by the addition of the Model E9.119 Numerical Integration Processor (NIP). This unit, introduced by Applied Dynamics, Incorporated in 1978, is designed to execute a variety of integration algorithms with 48 bit precision. This long word permits the NIP to integrate systems of equations having time constants differing by about 10^4 without suffering roundoff error. Such "stiff" systems of equations, which may be experienced in the design of an advanced modular missile, require very special techniques on general purpose computers.¹⁰ The NIP is a plug-in expansion to the AD-10 and its design permits modeling of commonly occurring phenomenon such as hysteresis, dead zone, and limit stop.

9. ADI Staff, "Simulation: As We See The Future." *Simulation*, Volume 29, No. 5, November, p. 184.

10. D. Garfinkel, C.B. Marbach, and N.Z. Shapiro, "Stiff Differential Equations," *Annual Review of Biophysics and Bioengineering*, Vol. 6, 1977, p. 525-542.

3. CONCLUSIONS AND RECOMMENDATIONS

A. CONCLUSIONS

- The AD 10 has been programmed in assembly language code to support the generation of aerodynamic coefficients in the real-time Homing and Laser Simulation (HALS).
- An interface program has been developed and tested which permits the Sigma 5 digital computer to interface with the AD 10 via the CI-5000 analog computer.
- A significant increase in speed of generating aerodynamic coefficients in a 6-degree-of-freedom missile simulation has been demonstrated thus allowing for efficient time simulation of existing systems.
- The need for additional AD 10 memory and an External Computer Interface module was demonstrated.

B. RECOMMENDATIONS

- Additional memory should be added to the AD 10 in anticipation of large aero coefficient data base for the Army Advanced Modular Missile research program.
- The External Computer Interface (EXCI) unit should be added to the AD 10 to permit digital data to pass between the Sigma 5 and AD 10.
- Consideration should be given to adding the Numerical Integration Processor (NIP) to the AD 10 so as to supplement/replace the analog computers in the simulation, thereby allowing more complex research systems to be analyzed.

REFERENCES

1. Pastrick, H.L., Homes, W.H., Will, C.M., Ison, L.S., and Jolly, A.C., "Real-time Hybrid Hardware-in-the-Loop Simulation of a Terminal Homing Missile." *Proceedings of the 1973 Summer Computer Simulation Conference*, Montreal, Canada, July 1973, pp. 264-268.
2. Pastrick, H.L., Will, C.M., Isom, L.S., Hazel, L.H., Vinson, R.J., "Hardware-in-the-Loop Simulations: A Guidance System Optimization Tool," *Paper No. 74-929, AIAA Mechanics and Control of Flight Conference*, Anaheim, California, August 1974.
3. _____, "The Efficacy of Hardware in Validating Hardware-in-the-Loop Simulations," *Proceedings of the 1975 Summer Computer Simulation Conference*, San Francisco, California, July 1975, pp. 561-571.
4. _____, "Hardware-in-the-Loop Simulation of a Digital Autopilot," *Proceedings of the 1978 Summer Computer Simulation Conference*, Newport Beach, California, July 1978, pp. 231-235.
5. Pastrick, H.L.; Will, C.M.; Isom, L.S.; Jolly, A.C.; Hazel, L.H.; and Vinson, R.J. "Recent Experience in Simulating Missile Flight Hardware in Terminal Homing Applications," *Proceedings of the Optics in Missile Workshop*, Society of Photo-Optical Instrumentation Engineers, Los Angeles, California, January 1970.
6. Karplus, W.J., "Peripheral Processors for High-Speed Simulation," *Simulation*, Volume 29, No. 5 November 1977, pp. 143-153.
7. Bensinger, R.H., "Real Time Simulation of Six Degree-of-Freedom Multivariable Forces and Moments in Less than One Millisecond," Missile Systems Division, Rockwell International, Columbus, Ohio, 1978.
8. Griner, G.M., "Aerodynamic Coefficient Data Plots for Hellfire Modular Missile System Flight Test Configuration," Science Applications, Inc., SAI-80-524-HU, 5 March 1979.

REFERENCES (CONCLUDED)

9. ADI Staff, "Simulation: As We See The Future." *Simulation*, Volume 29, No. 5 November 1977, p. 184.
10. Garfinkel, D., Marbach, C.B., and Shapiro, N.Z., "Stiff Differential Equations," *Annual Review of Biophysics and Bioengineering*, Volume 6, 1977, p. 525-542.

DISTRIBUTION

	No. of Copies
Commander Defense Documentation Center ATTN: DDC-TCA Cameron Station Alexandria, VA 22314	12
Commander US Army Research Office ATTN: DRXRO-PH, Dr. R. Lontz P.O. Box 12211 Research Triangle Park, NC 27709	5
US Army Research & Standardization Group (Europe) ATTN: DRXSN-E-RX, Dr. Alfred K. Kedoluha Box 65 FPO New York 90510	1
Commander US Army Material Development & Readiness Command ATTN: Dr. James Bender Dr. Gordon Bushy 5001 Eisenhower Avenue Alexandria, VA 22333	1
Hq, Department of the Army Office of the DCS for Research, Development & Acquisition ATTN: DAMA-ARZ Room 3A474, The Pentagon Washington DC 20310	1
OUSDR&E ATTN: Mr. Leonard R. Weisberg Room 301079, The Pentagon Washington DC 20301	1
Director Defense Advanced Research Projects Agency 1400 Wilson Blvd. Arlington, VA 22209	1

		No. of Copies
OUSDR&E		1
ATTN: Dr. G. Ganota		
Deputy Asst. for Research (Research in Advanced Technology)		
Rm 301067, The Pentagon		
Washington DC 20301		
DRDMI-X,	Mr. McKinley	1
DRDPM-HF,	COL Pellegrini	1
	Mr. Whitley	1
-HFE,	Mr. Comer	1
-CAWS-FO,	Mr. Keat	1
	Dr. Wall	1
	Mr. Harris	1
DRDMI-C,	Mr. Mangus	1
DRDMI-T,	Dr. Kobler	1
-TG,	Dr. Huff	1
	Mr. Johnson	1
-TGG,	Mr. Ciliax	1
-TGL,	Mr. Stripling	1
	Mr. Jones	1
-TGC,	Mr. Griffith	1
	Mr. Warren	1
	Mr. Bauman	1
-TGN,	Mr. Lewis	10
	Mr. Gambill	1
	Mr. Kelley	1
-TGT,	Dr. Leonard	1
	Dr. Yates	1
	Mr. Alongi	1
-TD,	Dr. McCorkle	1
-TF,	Mr. Atkins	1
-TK,	Dr. Rhoades	1
-TL,	Mr. Lewis	1
-TN,	Mr. Dobbins	1
-TE,	Mr. Lindberg	1
-TEO,	Mr. Widenhofer	1
-TR,	Mr. Bates	1
	Dr. Curtis	1
-TRT,	Dr. Hartman	1
	Dr. Bennett	1
-E,	Mr. Lowers	1
-ET,	Mr. Black	1
-TFG,	Mr. Fowler	1
-YOR,	Mr. May	1

DISTRIBUTION (CONCLUDED)

		No. of Copies
DRDMI-V,	MAJ Love	1
-TI		2
-TBD		3
DRSMI-LP, Mr. Voigt		1
IIT Research Institute ATTN: GACIAC 10 West 35th Street Chicago, Illinois 60616		1